

UNIVERSAL
LIBRARY

OU_210314

UNIVERSAL
LIBRARY

OSMANIA UNIVERSITY LIBRARY

Call No. 744/279F

Accession No 34441

Author Zipprich, A. E.

Title Freehand drafting for technical
sketching. 1957.

This book should be returned on or before the date last marked below.

FREEHAND DRAFTING

FOR TECHNICAL SKETCHING

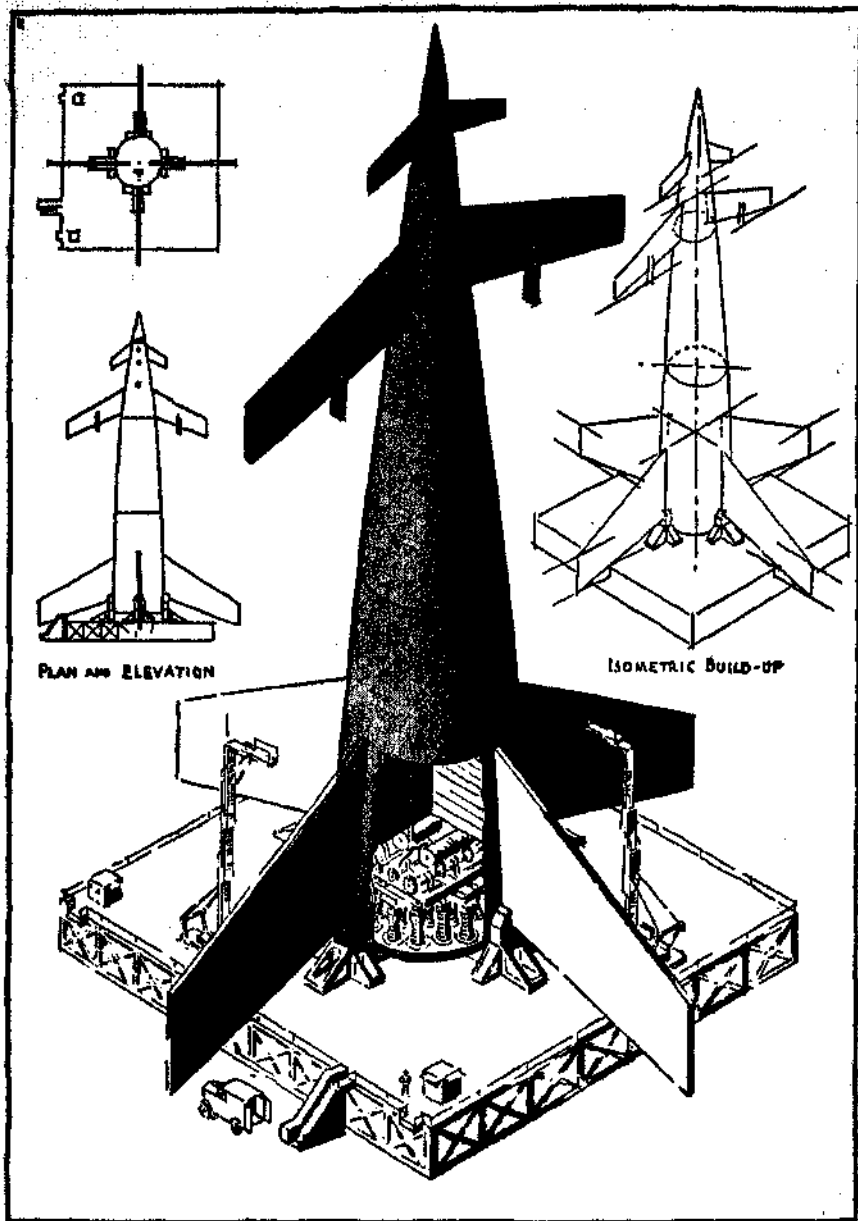

TECHNICAL ILLUSTRATION. SHADED ISOMETRIC DRAWING.
Adapted from color illustration by Rolf Klep of a three-stage rocket ship prior to take-off, in *Across the Space Frontier*, edited by Cornelius Ryan (Viking Press).

FREEHAND DRAFTING

FOR TECHNICAL SKETCHING

ANTHONY E. ZIPPRICH

*Formerly Teacher of Mechanical and
Freehand Drafting at Mechanics Institute
and at Murray Hill High School, New York City*

THIRD EDITION



WITH AN INTRODUCTION BY
CARL L. SVENSEN, B.S., M.E., LL.D.

D. VAN NOSTRAND COMPANY, INC.

TORONTO

NEW YORK

LONDON

NEW YORK

D. Van Nostrand Company, Inc., 250 Fourth Avenue, New York 3

TORONTO

D. Van Nostrand Company (Canada), Ltd., 25 Hollinger Rd., Toronto

LONDON

Macmillan & Company, Ltd., St. Martin's Street, London, W.C. 2

COPYRIGHT, 1924, 1943, 1954 BY
D. VAN NOSTRAND COMPANY, INC.

Published simultaneously in Canada by
D. VAN NOSTRAND COMPANY (Canada), LTD.

AH rights in this book are reserved. Without written authorization from D. Van Nostrand Company, Inc, 250 Fourth Ave., New York 3, N. Y, it may not be reproduced in any form in whole or in part (except for quotation in critical articles and reviews), nor may it be used for dramatic, motion-, talking-picture, radio, television, or any other similar purpose.

*First Published, August 1924
Ten Reprintings
Second Edition, September 1943
Six Reprintings
Third Edition, June 1954*

PRINTED IN THE UNITED STATES OF AMERICA

PREFACE TO THIRD EDITION

In recent years, many revolutionary changes have taken place in art, music, literature, architecture, and aviation. The important field of engineering known as mechanical drafting has been no exception. For example: outline shading on working drawings, ornamental borders and titles, and other time-consuming practices have been discontinued; symbols for the aircraft, welding, and electronic industries have been added to existing symbols; the Reinhardt letter has established its excellence for engineering drawings; and the practice of placing dimensions to read from one position, the bottom of the sheet, is becoming accepted practice in many industries.

A further change in keeping with the trend toward saving time in reading drawings has been the development of pictorial drafting into a major practice. Isometric drawings with elaborate shading, and the representation of assemblies in the unique manner of showing the parts as though the whole had been "exploded" to separate the parts, have become accepted practice for many purposes.

This third edition of *Freehand Drafting*, now entitled *Freehand Drafting for Technical Sketching*, presents some of the newer techniques in mechanical drawing and recognizes the advantages of technical sketching. Seven new exercises, twenty-five new problems, and twenty plates have been added, as well as new text material on estimating proportions, on optional shading methods, and on production illustration, with problems.

Photoprints from the Helicopter Division of the Bell Aircraft Corporation of Fort Worth, Texas, and from the L & J Press Cor-

poration of Elkhart, Indiana, as well as pictures from *Popular Science*, *Popular Mechanics*, and *Machinery* have been adapted for this revision.

To these corporations and journals and to Dr. Carl L. Svensen, Consulting Engineer, who, as in the past, has come to the aid of the author in editing the new material, revising Chapter 1, and suggesting additional exercises, grateful acknowledgments are herewith made.

A. E. Z.

May, 1964

CONTENTS

CHAPTER	PAGE
PREFACE TO THIRD EDITION	V
INTRODUCTION BY CARL L. SVENSEN	3
1. MECHANICAL AND FREEHAND DRAFTING	5
Methods of Description — Mechanical Drawings — Sketching — The Design Sketch — Orthographic Sketches — Pictorial Sketches — Purposes — Mate- rials for Sketching.	
2. FREEHAND LETTERING.	9
Lettering for Sketches — Styles of Letters, Roman, Gothic, Script, Block — Single Stroke Letters — Ver- tical Capitals — Proportions of Letters — Vertical Lower Case — Inclined Capitals and Lower Case — Numerals and Fractions — Spacing — Choice of Letters — Lettering Exercises.	
3. FREEHAND SKETCHING PRACTICE	21
The Basis of Useful Sketching — Horizontal Lines — Vertical Lines — Slant Lines — Quality of Lines — The Circle — Tangents — Practice Exercises.	
4. GEOMETRICAL DEFINITIONS.	35
Geometry and Sketching — Uses of Geometry — Point, Line, and Plane — Circles, Arcs, Etc. — Vari- ous Curved Figures — Triangles, Quadrilaterals, and Polygons — Prisms, Cylinders, Etc. — Practice Ex- ercises.	

5. PRINCIPLES OF PROJECTION**47**

Methods of Representation — Working Drawings — The Planes of Projection — How the Views Are Obtained — Placing the Views — Representation of Hidden Surfaces — Obtaining Views from Model — Proportion — Proportioning and Estimating Measurements — Auxiliary Views — Problems.

6. SECTIONAL VIEWS**75**

Representation of Interior Construction — Principle of the Sectional View — Cross-Hatching — The Imaginary Cutting Plane — Kinds of Sectional Views — Treatment of Shafts, Bolts, Etc. — Exceptions to the Rule of Sectioning — Special Sections — Problems.

7. CONVENTIONAL PRACTICE**87**

Conventional Methods — Full Lines — Hidden Lines — Center Lines — Cutting Plane Lines — Extension Lines — Dimension Lines — Dimensioning — Scale Drawings — Conventional Representations — Working Sketches — Shop Sketch — Problems.

8. ISOMETRIC SKETCHING**113**

Kinds of Pictorial Representation — Uses of Pictorial Representation — Principles of Isometric Drawing — Non-isometric Lines — Circles and Curves — Irregular Shapes — Isometric Sections — Reversed Axes — Isometric Sketching Problems.

9. ASSEMBLY VIEWS**129**

Assembly Drawings and Sketches — Special Assemblies and Layouts — Pictorial Assemblies — "Exploded" Assemblies — Analysis of Isometric Assembly Drawings — Sketching Large Assemblies — Problems.

CONTENTS

ix

CHAPTER

PAGE

10. PRODUCTION ILLUSTRATION	147
Pictorial Technical Drawings — Exploded Drawings — Uses of Production Illustration — Procedure — Problems.	
11. SHADED SKETCHES AND DRAWINGS	157
Uses of Shaded Drawings — Kinds of Shading — Outline Shading — Surface Shading — Shading Iso- metric Drawings — Flat Surfaces — Curved Surfaces — Optional Methods of Shading — Shading Problems.	
INDEX.	173

FREEHAND DRAFTING

FOR TECHNICAL SKETCHING

INTRODUCTION

BY

CARL L. SVENSEN, B.S., M.E., LL.D.

The many and frequent changes and improvements which are a part of present industrial practice, especially in the manufacture of aircraft and aircraft parts, and the many kinds of equipment for all purposes, make a working knowledge of freehand drafting or sketching not only desirable but practically necessary.

The purpose of this book is to meet this universal need by presenting the graphic language (the language of industry) in a series of simple, progressive, and easily understood lessons. In this way a sufficient knowledge of the subject to be of real practical value in every-day work can be acquired without long or difficult study. The use of freehand methods provides a direct way of learning the meaning of drawings used in manufacture and construction of all kinds such as aircraft, motor vehicles, machinery, equipment, structures, and ships.

The ability to visualize material forms has become one of the important requirements of success for all who are engaged in engineering or industrial work. The best means for the development of this faculty is by a study of freehand drafting. The time required and the necessity of having extensive equipment impose many limitations upon the teaching and use of mechanical drawing. The tools of drafting are a convenience and under certain conditions are necessary for using the graphic language efficiently. However, it seems to be more and more necessary to point out the fact that the tools of drafting do not constitute the subject of drafting and that under many conditions they can be dispensed with to considerable advantage.

Those who read and use the graphic language in the form of drawings greatly outnumber those who make them. The statement has often been made that drawing can be learned without the use of instruments. In this book a way has been provided for the systematic study of freehand drafting. Text illustrations and problems combine to furnish a means of developing the ability to read drawings and to make and use freehand sketches with assurance and skill.

Knowledge of a subject has no value unless that knowledge can be applied to a useful purpose. The illustrations and problems indicate many practical applications of freehand drafting or sketching. The only tools needed are a pencil and paper. With these the interesting fields of graphic description, invention, and drafting generally can be explored and used.

The value of freehand sketching cannot be overestimated for engineers, foremen, shop superintendents, squad leaders, mechanics, and all industrial workers in aircraft plants, equipment factories, and shipyards.

This book supplies the means for acquiring the ability to understand and to use practical drafting by presenting an adequate treatment of freehand methods.

MECHANICAL AND FREEHAND DRAFTING

Methods of Description. — Industrial products, machines, and constructions, whether simple or complicated, have to be described before they can be made. Methods of description include words, pictures of various kinds, and engineering drawings composed of a number of views drawn to scale, with different kinds of lines arranged according to certain geometrical principles. Representations drawn to scale with instruments and other equipment are made by *mechanical drafting*. Representations drawn freehand using only pencils and paper are made by *freehand drafting* or sketching. The language of industry uses all of these methods of description, and they should be understood by all who are engaged in engineering work of any kind. Both freehand and mechanical drawings are made for the description of machinery, buildings, electrical work, sheet metal layouts, automobiles, ships, airplanes, topographic and other maps, and all kinds of engineering projects.

However, more and more emphasis is being placed on pictorial drawings — either freehand or mechanical — because of the ease with which they can be read. They save time and so speed production and assembly. Pictorial drawings are especially valuable and much used to represent spare or replacement parts for manuals of assembling and operation and all kinds of technical illustration.

Mechanical Drawings are so called because they are made with the aid of compasses, dividers, the T-square triangles, scales, etc. For greater speed and convenience, drafting machines are generally used in engineering drafting rooms. The making of mechanical

drawings, use of the tools and equipment, etc., form a separate subject for study in other books.

However, the theory upon which all drawings are based and the modifications and conventional treatments which have been found desirable in practical use, are the same for either mechanical or freehand drafting.

Sketching. — Drawings made by sketching with a pencil or pen constitute freehand drafting. Such drawings permit greater freedom in drawing because they are not restricted by the use of tools and scales. Freehand drawings provide a quick and convenient means of developing design ideas, of explaining shapes and arrangements of parts, and of providing descriptions and explanations for manufacture or any other engineering or industrial purposes.

The Design Sketch. — The development of a design or project often starts with idea sketches. As many sketches as necessary to develop a promising scheme are made, and the best one is used for starting a design drawing. This drawing is used to develop the design, to fix distances, and essential sizes. From such a design drawing or layout, the detail or working drawings are made with dimensions, notes and all necessary information. Such drawings are usually made on tracing paper with a sufficiently dark pencil to allow blueprints or other prints to be made.

Orthographic Sketches. — Most engineering drawings are multi-view drawings made up of two or more views obtained by orthographic projection. Orthographic sketches or freehand drawings are based upon the same principles of projection and consist of separate views properly arranged as described in Chapters 5, 6, and 7.

Pictorial Sketches. — Single pictorial views sketched freehand form an important part of graphical description. There are many kinds of pictorial drawings. Isometric sketches are simple to understand, easy to make, and are suitable for a great many engineering and technical purposes. Therefore, isometric sketching is thoroughly explained and used in this book.

Purposes. — Freehand drafting (both multi-view sketches and pictorial sketches) have many uses as indicated in previous paragraphs. An important purpose is learning to read drawings and blueprints of all kinds. Other purposes include specifying changes, describing parts, explaining production, assembly, and operation in all fields of engineering — the aircraft industry, the automotive industry, manufacturing, etc.

When original drawings are not available, sketches may be made from an existing machine or construction if it is necessary to duplicate the work. Broken parts of machinery are often sketched when repairs or replacements are required. Experimental work, inventions, improvements and modifications are made and recorded by sketches which can be used for information when permanent drawings are made.

Pictorial production drawings, exploded views and other pictorial technical drawings are being used for more and more engineering purposes. Facility in making and reading freehand drawings is necessary for everyone who has a part in engineering or industry. Skill in freehand drafting requires systematic practice as provided by the exercises in this book.

Materials for Sketching. — A pencil, an eraser, and paper provide all the equipment necessary for making freehand drawings.

Pencils are made in various grades of hardness. An F or HB drawing pencil or a No. 1 writing pencil will be satisfactory for most papers. Too hard a pencil is difficult to work with and too soft a pencil will make lines and figures that smudge easily. The wood should be cut away at a long slope leaving about $\frac{1}{8}$ inch of lead exposed. For line work, the lead should be sharpened to a long conical point and should not be allowed to become blunt. Mechanical pencils using a small diameter of lead are convenient and provide a uniform line. Special fountain pens are available with different kinds of points for freehand drawing.

Plain paper in pad form is convenient for making sketches. Small pads that will fit the pocket serve very well for many pur-

poses. Cross-section or square-ruled paper is useful in maintaining straight lines and securing good proportions. " Isometric " ruled paper is convenient for keeping the directions of the lines and in sketching isometric circles and arcs.

2

FREEHAND LETTERING

Figures and notes which tell sizes and give necessary information, form a part of most sketches. Every sketch, no matter how simple, should have a title to tell what it is, who made it, and when it was made. Writing can sometimes be used. Most writing, however, is not easily read and it is frequently impossible to decipher hastily written notes after a lapse of time. In the interest of efficiency, lettering should be used on all sketches. Good lettering does help the appearance of a drawing or sketch but its real advantage is legibility which saves time and prevents mistakes.

Not everyone can become expert in lettering but all can learn the correct forms of the letters and the required proficiency is then simply a matter of practice. Good plain lettering is becoming so general that it is expected as a matter of course from all who make use of the graphic language.

Styles of Letters. — There are four general styles of letters, — Roman, Gothic, Script, and Block. A considerable variation may exist in each of these styles. Egyptian Hieroglyphics present a striking contrast when compared with the draftsman's single stroke letter of today, Plate 1, at B. Ancient Egypt is considered as the source of our alphabet which underwent changes by the Phoenicians and Greeks and finally reached the Romans who gave the letters the forms we now recognize.

Single Stroke Letters. — One style of letters will suffice for sketches. They may be either vertical or inclined and can be made with lines the width of a single pencil stroke. Such letters are called single stroke letters although they are really formed by a number of single strokes.

A. **ROMAN Gothic**
Script **BLOCK**

B-  TUTANKHAMEN

A B C D E F G H I J K L M N O P Q R S
T U V W X Y Z & 1 2 3 4 5 6 7 8 9 0 $\frac{1}{2}$ $\frac{3}{4}$ $\frac{5}{8}$
a b c d e f g h i j k l m n o p q r s t u v w x y z

A a b g *A a b g* G K k
(two-thirds cap height) (one-half cap height)

A B C D E F G H I J K L M N O P Q R S T U
V W X Y Z & 1 2 3 4 5 6 7 8 9 0 $\frac{1}{2}$ $\frac{7}{16}$ $\frac{9}{16}$
a b c d e f g h i j k l m n o p q r s t u v w x y z

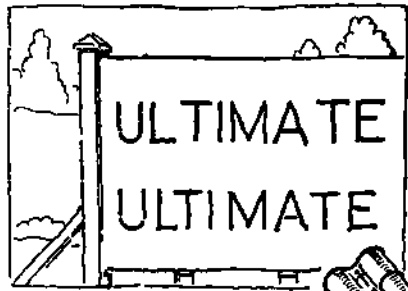
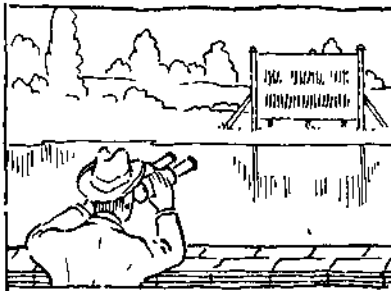

Poor Spacing

ULTIMATE

DETAILS

REGULATION

Good Spacing

ULTIMATE

DETAILS



REGULATION

PLATE 1. Alphabets and Spacing.

Alphabets of vertical letters, both CAPITAL and lower case are shown on Plate 1. The capital letters can be arranged according to shape in four groups as follows: Right angle letters made up of straight lines at right angles to each other; Acute angle letters made up of straight lines at an acute angle with each other; Round letters made up of curved lines; and a remainder group made up of straight lines or straight lines and curves. Practice exercises are shown in connection with the groups of letters on Plate 2.

The proportions of the various letters should be observed. The letter I is formed by a single stroke, the letter W is wider than it is high, the letters A, M, V, X, and Y have a width equal to their height, and the remaining letters are less in width than height by varying amounts.

The vertical lower case or small letters can be arranged in groups as indicated on Plate 2. Note the proportions in comparison with the capitals on Plate 1. The small " a " is about two thirds as high as the capital or large A. The letters a, b, d, g, p, and q have the same " body " form. Other characteristics may be observed by a study of the letters as illustrated. Sometimes the body of the small letters is made one half the cap height, but if the capitals are not very large the two thirds proportion is better especially on sketches. Small letters can be made more easily and in less time than caps. Words composed of small letters have characteristic shapes which are familiar and therefore are quickly read.

Slant or inclined capitals and small letters are shown on Plate 1. These may be studied in the same way as the vertical letters. A few guide lines at an angle as shown will be of help in securing a uniform slope for the letters.

Numerals and fractions require particular attention and should always be correctly formed. The fraction numbers are made a little smaller than whole numbers. The division line should always be horizontal.

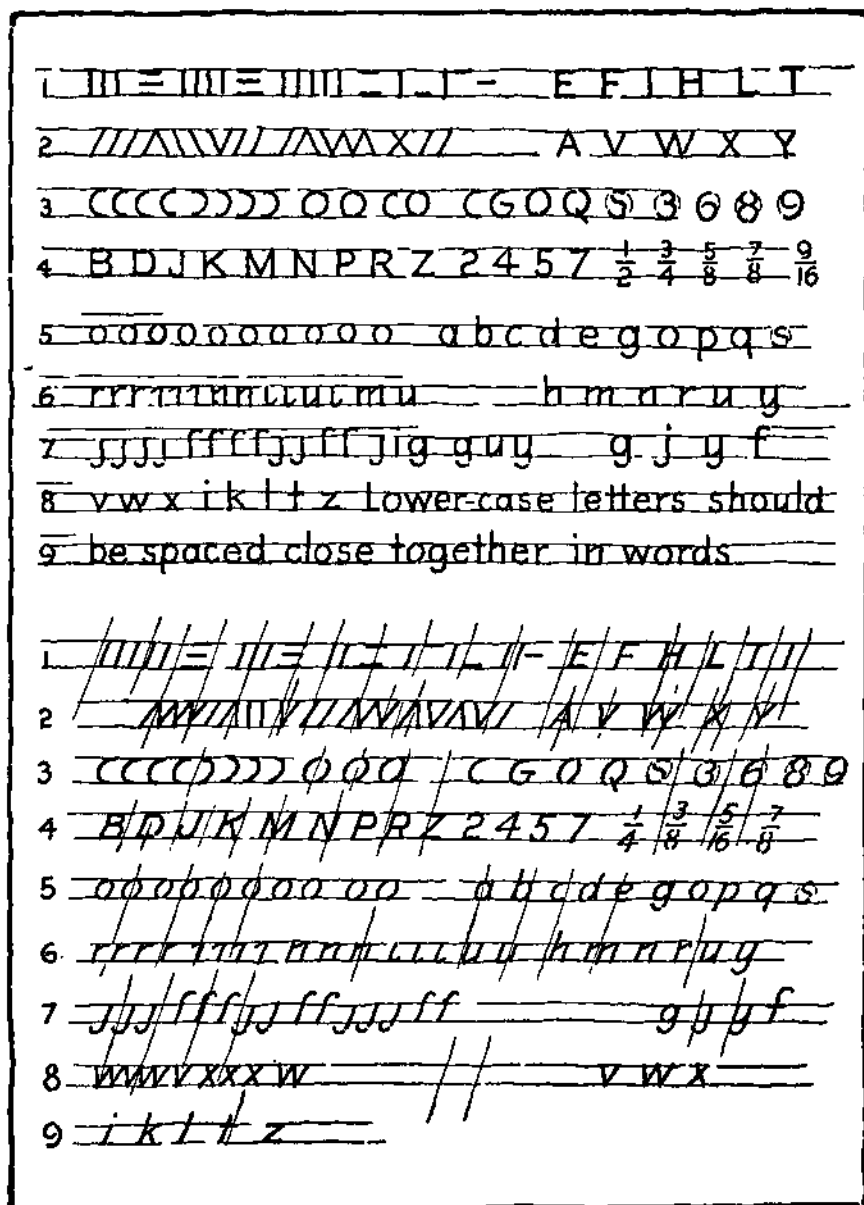

PLATE 2. Lettering Exercises.

*/ /
The Inclined Lower- Case Letter. i l l*

*rr This single-stroke Letter is the most practical
³/₈ form for use on drawings and notes for / l
¹/₈ sketches. Because of its slant and variations
in height, words so lettered resemble
'writing. It can sometimes take the place
³/₁₆— of script because of the speed of execution
and the swing of lettering in this style.
Differences in height (if also make, for great-
er legibility, which is the reason, for the
use of vertical lower-case letters for type
employed in the printed page.*

THE VERTICAL CAPITAL LETTER.

^PRESENT DAY DRAFTING- ROOM PRACTICE

^FOLLOWS LARGELY TWO STYLES, THE LOWER-
ii_CASE INCLINED AND THE VERTICAL CAPITAL.

MANUSCRIPT WRITING, THE GRADE SCHOOL
METHOD OF LEARNING TO WRITE IS THE LOG-
ICAL WAY FOR THE BEGINNER. ALL-CAPS,
VERTICAL OR INCLINED HAVE A MECHANICAL
APPEARANCE CONSISTENT WITH TECHNICAL
DRAWINGS. ALWAYS USED FOR TITLES.
LEGENDS, BILLS OF MATERIAL AND NOTES
MAY BE SIMILARLY TREATED.

Spacing. — After the shapes and proportions of the letters have been learned, it is necessary to combine them into words. So far as possible the letters should be spaced so that each word appears as a unit. Two illustrations of a distant sign board are shown on Plate 1. When viewed through the large end of a field glass there appear to be two horizontal gray bands; the lower one an even tint, and the upper one somewhat broken or uneven. Upon reversing the glass the observer discovers that the gray bands are words, and that the letters are poorly spaced in the upper word, but well spaced in the lower word. This illustrates the difference between poor spacing and good spacing. The letters *cannot* be placed equal distances apart but must be located so that the areas between them will appear about equal. This is not a simple matter. The difference in the shapes of letters and the different combinations of letters make it necessary to consider the placing of the letters as they occur in each word.

The only rule which can be given is this general one: *make the areas between letters appear as nearly equal as possible*. The application of this rule is illustrated at the bottom of Plate 1. In the first example of each word the letters are placed equal *distances* apart which results in unequal *areas* between the letters as shown by the shaded areas below the words. Note that these areas are more nearly equal in the examples of good spacing. Sometimes it is necessary to modify one or more of the letters slightly to obtain the desired result. Letters with vertical sides should be further apart than letters with slanting or open sides.

Some examples of spacing for letters and words are shown on Plate 3 for inclined lower-case letters and for vertical capitals. The spacing between letters and the spacing between words should be studied. Notice that the letters in words are spaced to "hold together" so that each word appears as a single unit.

The plain lettering described in this chapter is all that is necessary for freehand sketches and general industrial purposes. Letter-

ing of itself is a field for extensive study beyond the scope of this book. For those who wish to pursue the subject further a thorough treatment of freehand lettering will be found in Reinhardt's "Lettering for Draftsmen," and a comprehensive treatment of the different alphabets and the whole field of lettering in Svensen's "The Art of Lettering"

Choice of Letters. — The alphabets of capitals and lower-case letters, both vertical and inclined, shown in this chapter are single-stroke engineering letters. The choice of letters, vertical or inclined, all capitals or capitals and lower case, is governed by company practice.

The American Standards Association recommended practice includes the following statements in regard to the sizes of lettering.

"It is not desirable to grade the size of lettering with the size of the drawing except when a reduced photographic reproduction of the drawing is to be made. In other words the size and weight of the lettering should be such as will produce legible prints from tracings either in pencil or in ink.

"Lettering should not be underlined except for particular emphasis."

Lettering Exercises. — As stated before good lettering is expected on industrial sketches. Either vertical or slant letters can be used and the student is advised to become proficient in one style before attempting the other. Use a well pointed pencil of about "H" grade. Practice carefully and without haste. It is necessary that some kind of guide lines be used for lettering even though they are drawn freehand.

For some of these exercises use squared paper if available.

SHEET LAYOUT. — The two layouts for sketching sheets indicated on Plate 4 are given for reference purposes. The use of a standard size sheet for all sketches will facilitate their preservation and handling,

EXERCISE 1. — Layout No. 1 of Plate 4. On upper half of sheet practice lines 1 and 2 of Plate 2. Make guide lines about $\frac{1}{4}$ inch apart at first and then repeat exercises with lines $\frac{1}{8}$ inch apart.

Paper for sketches may be any convenient size, but for most of the exercises in this book use either 8"x10" or 8½"x 11,

The borderline shown improves the appearance and gives excellent practice in sketching.

It may be placed about 6" from edges.

Make-up of title will vary but it should give the job or sheet number, tell what the

sketch is, who made it and when it was made

LAYOUT No.1

No. DATE TITLE NAME

LAYOUT No.H

SHEET No. DATE TITLE NAME

On lower half of sheet practice lines 3 and 4 in a similar manner. Do not hurry but observe each letter as made and compare it with copy. Patience is very necessary when beginning the study of lettering.

EXERCISE 2.—Layout No. 1 of Plate 4. Practice lines 5 to 9 of Plate 2. Make guide lines about $\frac{1}{4}$ inch apart for *body* of letters for first time, then reduce to $\frac{3}{16}$ inch and then estimate at slightly more than $\frac{1}{16}$ inch, or as directed by your instructor.

EXERCISE 3. — Layout No. 1 of Plate 4. Practice upper half of Plate 3. Make guide lines $\frac{3}{16}$ inch apart for body of letters for first time. Then estimate at slightly more than $\frac{1}{16}$ inch, or as directed by your instructor.

EXERCISE 4. — Layout No. 1 of Plate 4. Practice lower half of Plate 3. Otherwise same as Exercise 3.

EXERCISE 5. — Composition. Letter first paragraph of this chapter using capital letters $\frac{3}{16}$ inch high.

EXERCISE 6. — Composition. Letter first paragraph of this chapter using lower case letters.

MEMORANDA

3

FREEHAND SKETCHING PRACTICE

MEMORANDA

3

FREEHAND SKETCHING PRACTICE

A conscientious study of the methods of sketching straight lines and curves and practice in using these methods forms the basis of useful sketching. Without such practice the resulting sketch is often misleading and seldom satisfactory. The only alternative is to use the draftsman's tools. This requires a longer time and does not allow the freedom of thought that goes with freehand sketching.

The ability to do fair sketching which will answer for most useful purposes can be acquired by anyone who will spend a little time in careful practice of the fundamentals explained in this chapter.

Horizontal Lines.—The proper position for the hand when drawing horizontal lines is shown at the top of Plate 5. The arm should be kept close to the side and the pencil about at right angles to the line. Regardless of its length, a line must be sketched with an arm movement, that is the arm from elbow to fingers must travel along the line. When the hand alone is moved the resulting line will be irregular and slightly curved. This is a common fault with beginners.

Vertical Lines.—The position for the hand when sketching vertical lines is shown on Plate 5. Use an arm movement with the arm well out from the body and keep the pencil at right angles to the line. Vertical lines may be sketched either up or down as indicated. When drawing from the top downward more of the hand rests on the pad or table. The method which seems the more natural will generally give the better result.

Slant Lines.—The general rule of keeping the pencil at right angles applies to slant lines as indicated on Plate 5. When drawing

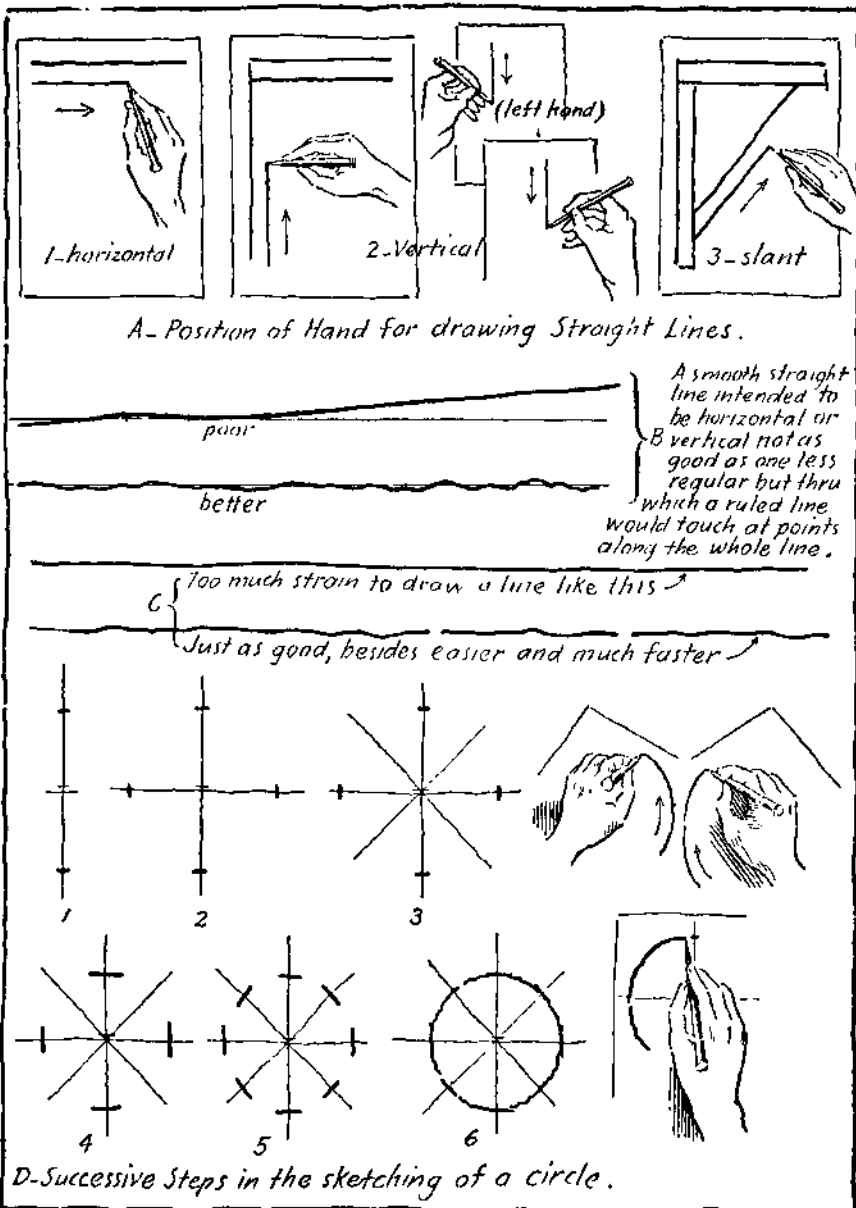

PLATE 5 Elements of Freehand Sketching.

from lower left to upper right, hold the pencil as shown with the arm partly away from the body. In the reverse direction, lower right to upper left, it is best to turn the paper so that the line is horizontal and draw it as such.

The directions given apply also to LEFT HAND WORKERS with the important exception that horizontal lines must naturally be drawn from *right* to left.

Quality of Lines. — Beginners generally attempt to get horizontal lines perfectly straight and smooth and in doing this depart from the horizontal direction. It is not necessary that the line be perfectly straight but its direction is important. Draw reasonably fast, keeping the direction, even though the resulting line is somewhat wavy. The upper or lower edge of the paper will serve as a guide until practice has improved one's skill.

Two freehand lines are shown at C, Plate 5. The upper one while very smooth required too much attention in drawing. The lower line will serve about as well, is easier to draw and can be done much faster. Holding the pencil above the paper and drawing several imaginary lines before making them on the paper is good practice. These suggestions, of course, also apply to vertical and slant lines.

The use to which a sketch is to be put will determine the character of its workmanship. Moderate speed and reasonable accuracy in form and proportion are essential.

The Circle, Semi-circle, and Quarter Circle. — Ordinarily circles are sketched too quickly resulting in shapes that often bear faint resemblance to circles. First, sketch vertical and horizontal center lines of a greater length than the diameter of the circle. Make marks on these lines equal distances on each side of the vertical line and above and below the horizontal line as shown on Plate 5. It is comparatively easy to estimate the equal horizontal distances but an optical illusion must be overcome when estimating the vertical distances. When the two distances are equal the upper

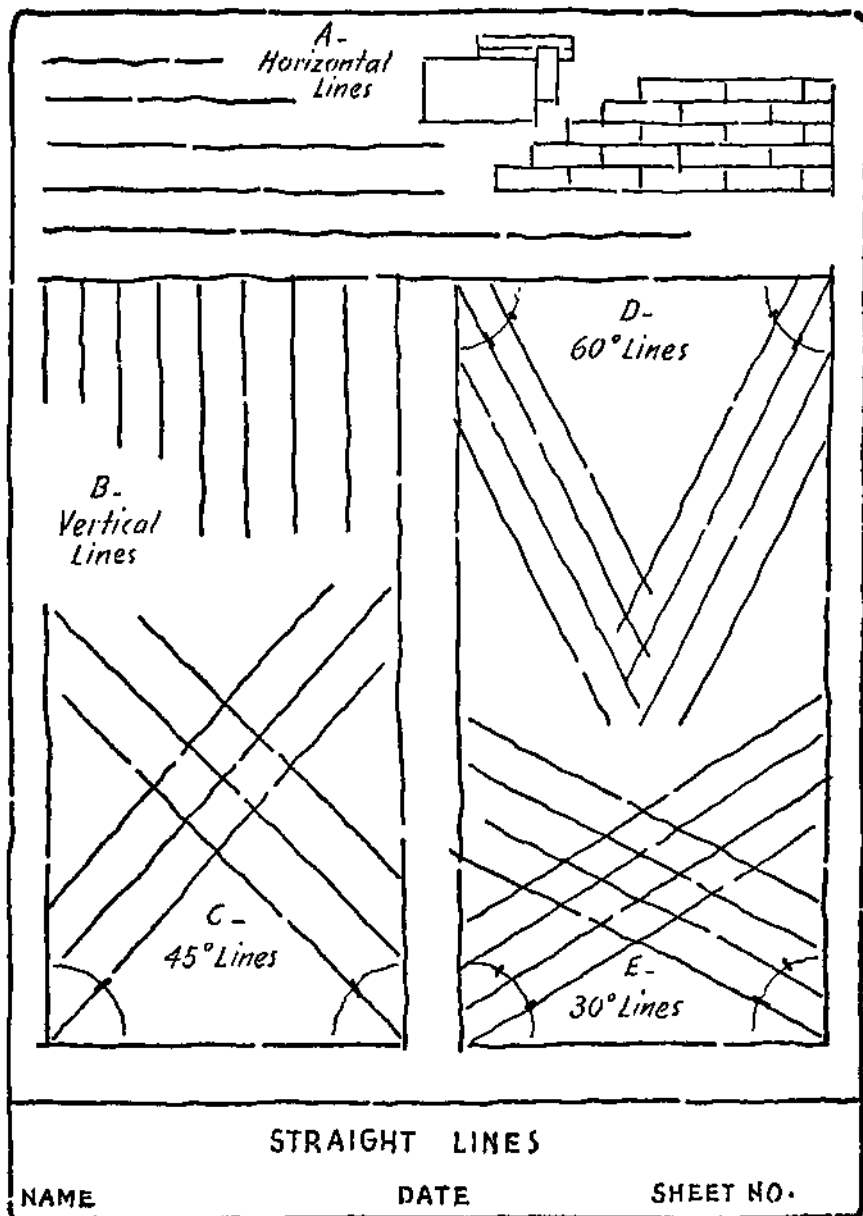

PLATE 6. Sketching Practice. Exercise 1.

one will appear to be greater. This must be kept in mind when estimating equal divisions.

After the vertical and horizontal distances are fixed, draw two additional lines 45 degrees with the first two lines and mark off the same equal distances as shown. This gives eight points through which a circle may be drawn freehand. After a little practice four points will be found enough to guide one in sketching a fairly good circle. Semi-circles and quarter or part circles are sketched with the same care.

Tangents. — When curves meet straight lines or different curves, they must be joined smoothly. Tangent arcs are shown on Plates 8 and 9. The exact point of tangency or joint should not show plainly. This result can be obtained by sketching the arc or line past the point of tangency rather than trying to stop at the exact point.

Practice Exercises. — The ground covered in this chapter while apparently simple is very important. Practice of the exercises which follow will develop the skill which is necessary for the successful study and application of all that follows.

Plain paper with a surface that will "take" the pencil line well should be used for sketching. A size 8 by 10 inches or 8% by 11 inches is desirable. Layout No. 1 of Plate 4.

EXERCISE 1. — Sketch the straight lines as shown on Plate 6 beginning with the horizontal lines at A. It is as important to learn to estimate equal distances between the lines as it is to get the lines in the right direction. Note how the direction is estimated for the lines at an angle.

EXERCISE 2. — Plate 7 is for practice in the use of straight lines. Observe the proportion of the sheet used for each sketch and block in the space to allow for it. Draw light horizontal lines for the borders at A and B and complete the designs. Sketch a rectangle for the figure at C, note the enlarged corner sketch at the left, then sketch the corners on the figure. Note that the corner designs are based on nine squares. Proceed to block in for each of the other figures in order, and complete them, one at a time.

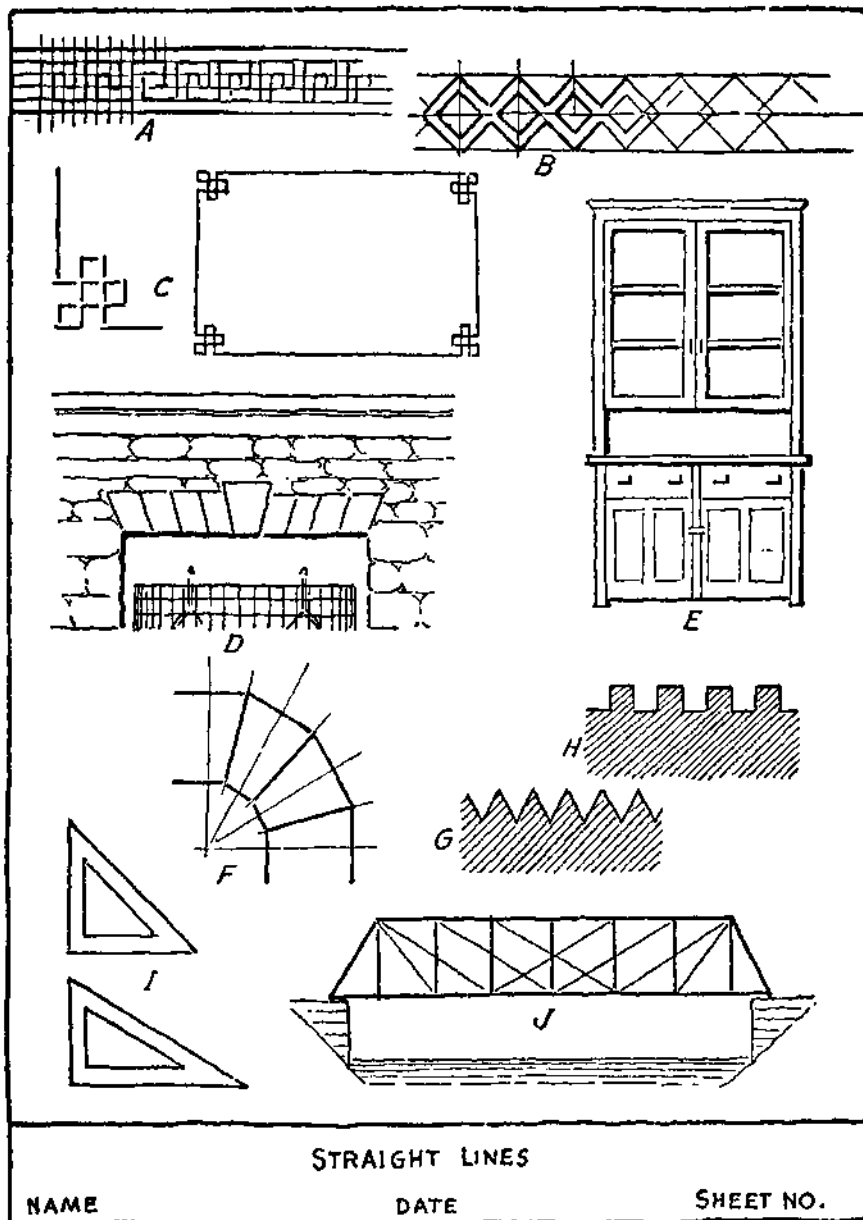

PLATE 7. Sketching Practice. Exercise 2.

EXERCISE 3. — In the upper half of the sheet sketch quarter circles of different sizes. Estimate radii very carefully and use construction lines as shown at A on Plate 8. In the lower half of the sheet sketch the half circles shown at B and C and the figures as at D and E.

EXERCISE 4. — Lay out the sheet as before. In the upper half sketch several complete circles as shown at A on Plate 9. Use center lines and estimate radii very carefully. In the lower left hand part of the sheet sketch the exercises shown at B and C on Plate 9, but with the arcs forming continuous lines. In the lower right hand part of the sheet sketch the exercise shown at D on Plate 9. Construct carefully and make the resulting line continuous. Complete the figure.

EXERCISE 5. — Plate 10 is for practice in the use of circles and arcs. Observe the general proportion of the sheet used for each design. Block in the space to allow for each sketch. Proceed to block in for each of the figures in order, and complete them, one at a time.

EXERCISE 6. — Plate 11 is for practice in the use of circles, arcs, and curves. Block in carefully with straight lines and sketch the curves as shown.

A -

B -

C -

D -

E -

CIRCLES AND ARCS

NAME _____ DATE _____ SHEET NO. _____

PLATE 8. Sketching Practice. Exercise 3.

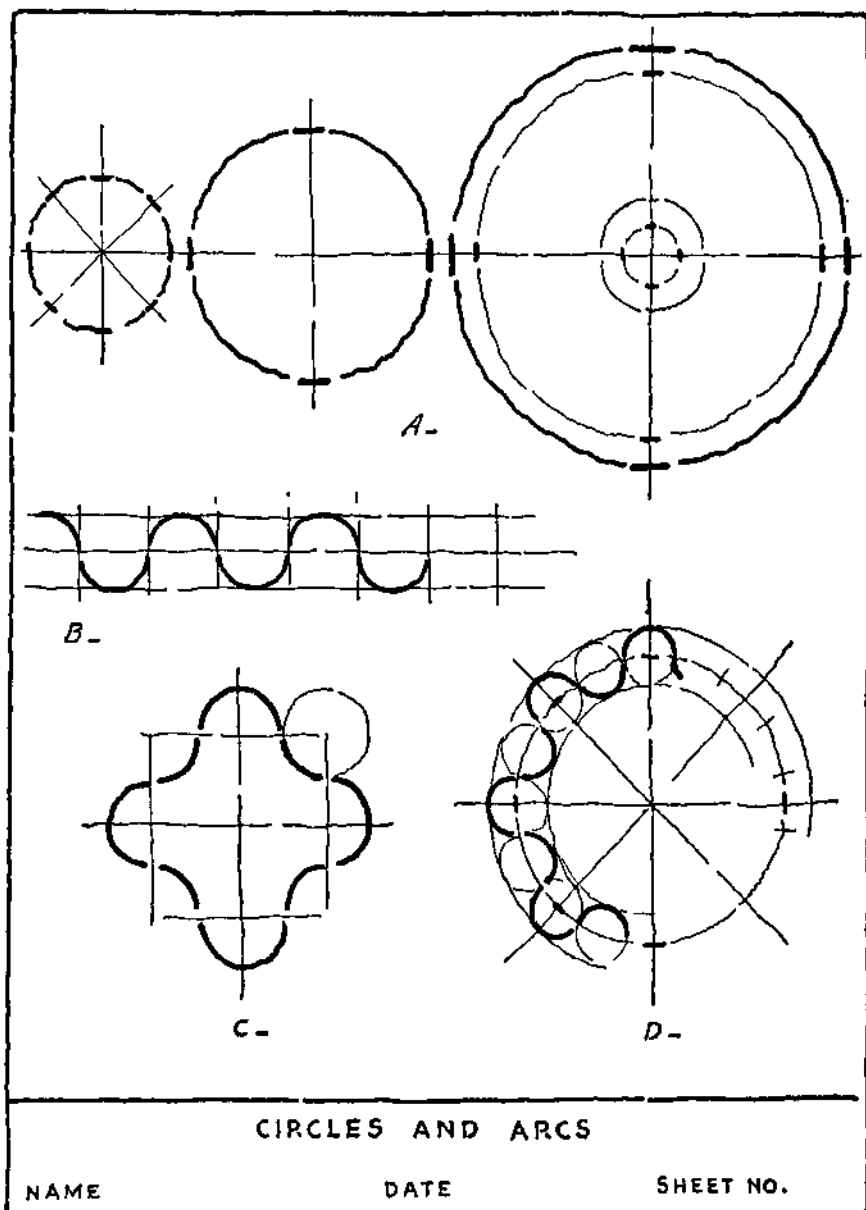

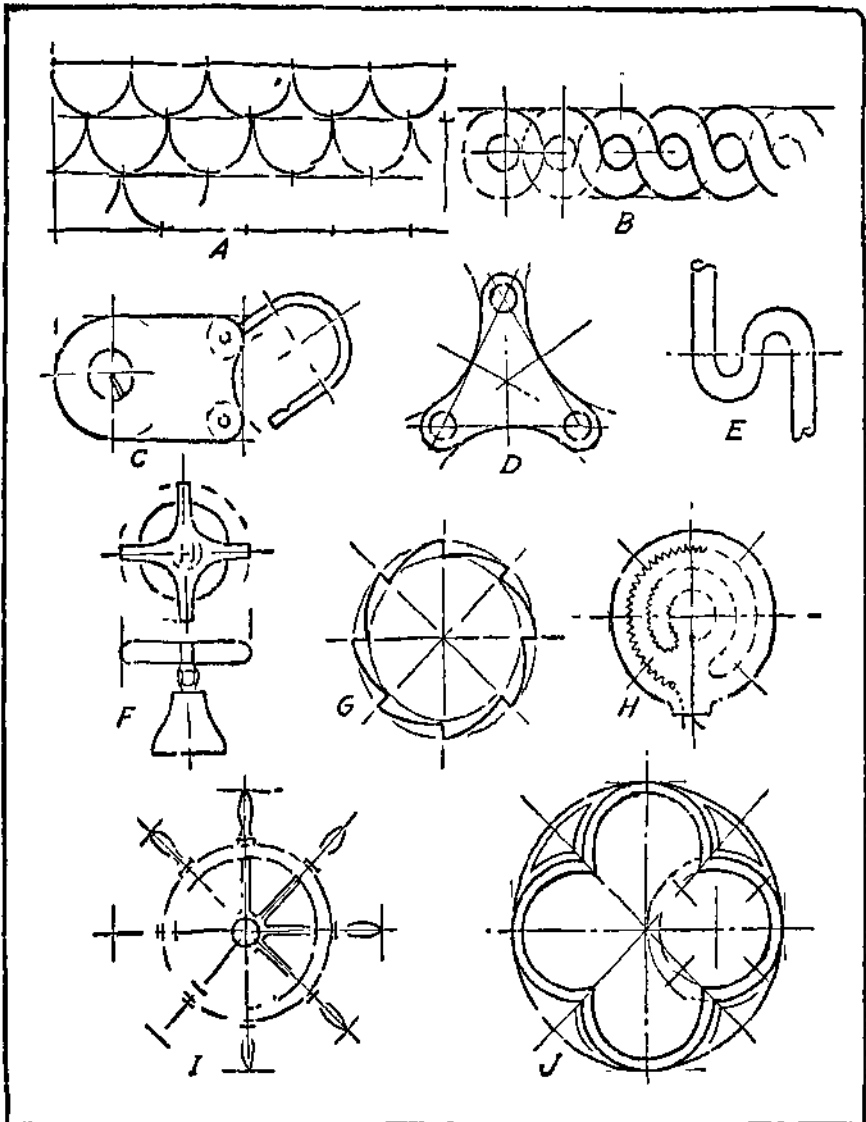

CIRCLES AND ARCS

NAME

DATE

SHEET NO.

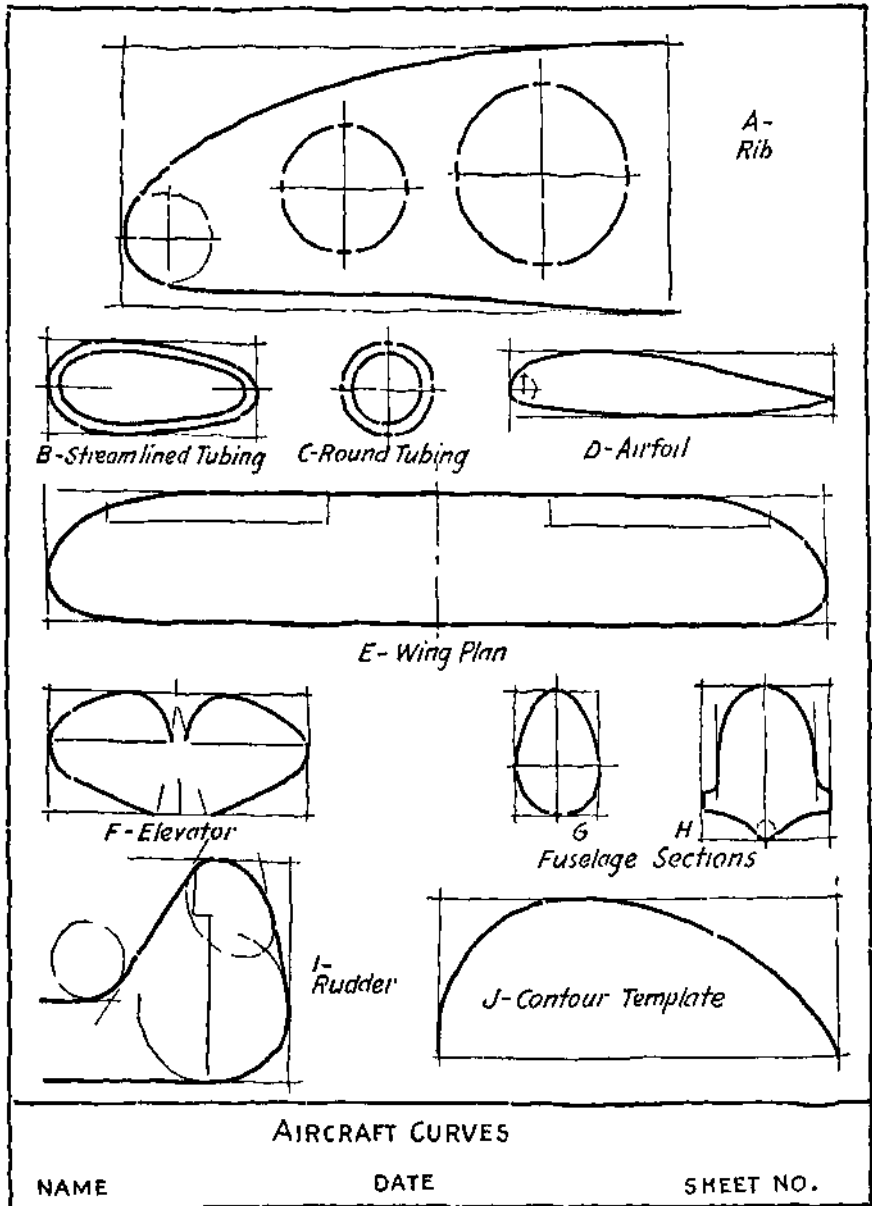

PLATE 11. Sketching Practice. Exercise 6.

MEMORANDA

GEOMETRICAL DEFINITIONS

MEMORANDA

4

GEOMETRICAL DEFINITIONS

Geometry is the basis of mechanical drawing and other graphical methods of shape description. An understanding of certain geometrical definitions is important in the study of freehand sketching. A geometrical figure is composed of points, lines, and planes. Plane Geometry deals with figures which lie in a plane. Solid Geometry deals with figures which have length, breadth, and thickness. There are several other kinds of geometry which need not be considered at this time.

Uses of Geometry. — Most mechanical objects have geometrical shapes, or are composed of geometrical figures. For this reason a knowledge of the characteristics of the principal geometrical figures will be of great value in making freehand sketches. The architect, builder, carpenter, engineer, machinist, surveyor, and all who have to do with industrial work, make use of the principles of geometry in their daily practice. The illustrations and definitions given in this chapter are selected to aid in the sketching work which follows.

Point, Line, and Plane. — A point denotes position in space. It has no length, breadth, or thickness. A line is a figure which has length but no breadth or thickness. It may be formed or generated by a moving point. A plane surface or plane has length and breadth but no thickness. A straight line is the shortest distance between two points. Two straight lines are parallel when they lie in the same plane and always have the same distance between them.

A horizontal line is one which is parallel to the horizon or line where the sky and earth seem to meet, Plate 12 at B and C.

A vertical line is one which meets a horizontal line, leaning neither to the right nor left. It is sometimes called an upright line or plumb line, Plate 12 at D.

A perpendicular line is one which meets any straight line in the same manner. Note that vertical and perpendicular do not have the same meaning.

When two lines meet, the opening between them forms an angle, Plate 12 at E.

Circles, Arcs, Etc. — A circle is a part of a plane surface, bounded by a curve all points of which are equally distant from the center point. The curve is called the circumference of the circle. Two or more circles of different sizes but having the same center are said to be concentric. The diameter of a circle is a straight line passing through the center, both ends terminating in the circumference. The radius of a circle is a line from the center to the circumference.

A tangent line is a straight line which touches a circle without penetrating it, even though continued. Tangent lines occur frequently in connection with half and quarter circles, Plate 12 at G. Circles tangent to each other also form a part of many views.

An arc is a part of a circumference. In mathematics the circumference is divided into 360 equal arcs or degrees ($^{\circ}$). A vertical line and a horizontal line drawn through the center of a circle will divide the circumference into four equal arcs, each of which will contain 90° . If the circumference is divided into six equal parts, each one will contain $360^{\circ} \div 6 = 60^{\circ}$. Angles are measured by the arcs opposite them. Thus the angle formed by radii from the center to the ends of one quarter of a circumference is an angle of 90° , Plate 12. Such an angle is called a right angle. Angles of less than 90° are acute angles and of more than 90° are obtuse angles, Plate 12 at E.

Two other curved figures of interest are the ellipse and the oval. An ellipse, Plate 12 at K, is defined as a curve formed by a point moving so that the sum of its distances from two fixed points is a

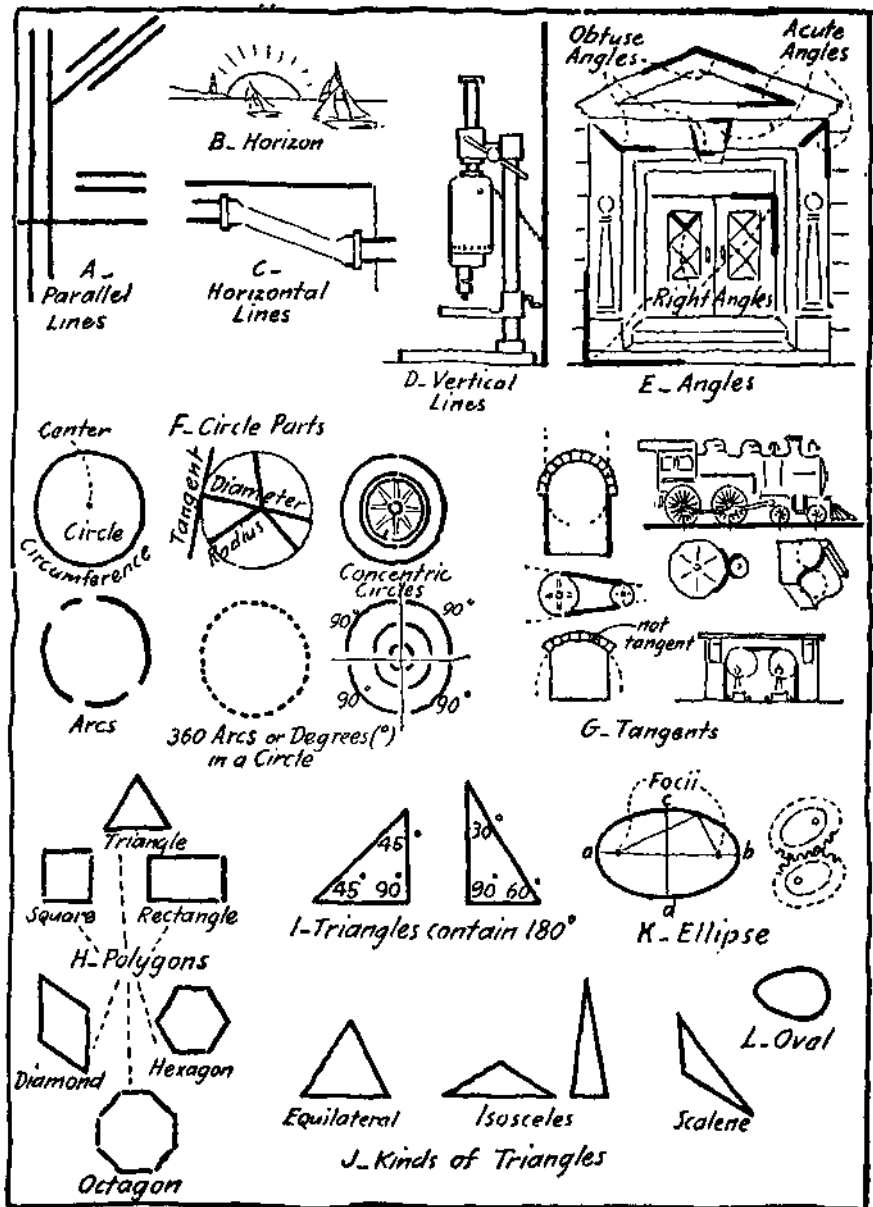

PLATE 12. Plane Geometry.

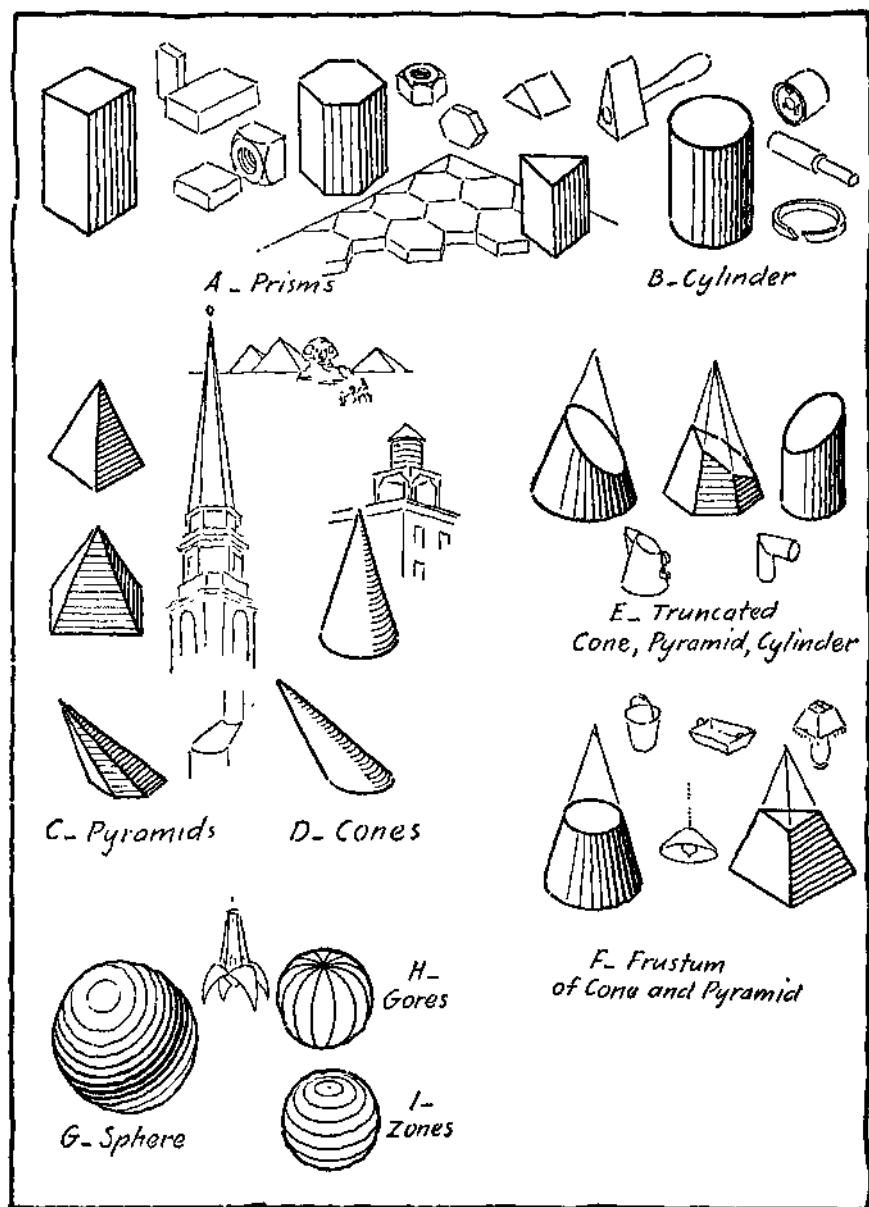

PLATE 13. Solid Geometry.

constant. These two points are called foci. One point is a focus. The longest line through the center (a-b) is called the major axis and the shortest line through the center (c-d) is called the minor axis. A circle when viewed at an angle appears as an ellipse.

An oval is an egg-shaped figure, Plate 12 at L.

Triangles, Quadrilaterals, and Polygons. — A polygon is a part of a plane surface enclosed by three or more straight lines. A polygon with three sides is a triangle. Equilateral triangles have three equal sides. Isosceles triangles have two sides or legs equal. Scalene triangles have no two sides equal.

The three angles of a triangle always total 180° . Thus an equilateral triangle has three angles, each of 60° , A right-angled isosceles triangle has one 90° and two 45° angles. The right-angled scalene triangle used by engineers, architects and draftsmen, has one 90° angle, one 60° and one 30° angle.

A quadrilateral is a plane figure bounded by four straight lines. A parallelogram is a quadrilateral having its opposite sides parallel. A rectangle is a parallelogram having four right angles. A square is a rectangle with four equal sides. A rhombus or diamond-shaped figure has four equal sides and no right angles.

A polygon with five sides is a pentagon.

A polygon with six sides is a hexagon.

A polygon with seven sides is a heptagon.

A polygon with eight sides is an octagon.

Prisms, Cylinders, and Other Solids. — A solid bounded or enclosed by polygons is called a polyhedron. When two of the polygons are equal and parallel the solid is a prism. The shape of the equal bases determines the name of the prism, as triangular prism, square prism, hexagonal prism, etc. A prism with six faces, all of which are square, is a cube.

A number of other type solids are illustrated and named on Plate 13. A cylinder having a circle for base is called a circular cylinder. This form occurs most frequently in mechanical constructions. A right circular cone has a circle for its base and its

vertex or point on a line perpendicular to the center of the circle.

Pyramids may have different shaped bases and are named accordingly, as triangular, square, rectangular, hexagonal, etc.

A truncated cone, pyramid, cylinder, or prism is one which has had the top part cut off by a plane at an angle with the base, Plate 13 at E.

A frustum of a cone or pyramid is one which has had the top part cut off by a plane parallel to the base, Plate 13 at F.

A sphere is a solid all points of whose surface are equally distant from an interior point called the center. The surface of a sphere can be divided into figures such as gores and zones. A gore is enclosed by two semicircles. A zone is contained within two circles in parallel planes.

The brief treatment of geometrical figures and solids included in this chapter is intended to give what is actually necessary as a preparation for satisfactory progress in freehand sketching of mechanical constructions.

Practice Exercises. — Use layout No. 1 of Plate 4.

EXERCISE 1. — Sketch a vertical line to divide the working space into two columns. In the left hand column sketch the following figures and letter name of each one: equilateral triangle, isosceles triangle, scalene triangle, right triangle, square, rhombus, pentagon, and hexagon. In right hand column illustrate by a sketch and letter the name of each of the following: octagon, rectangle, circle, right angle, tangent line, concentric circles, ellipse, and oval.

EXERCISE 2. — Use layout No. 1 of Plate 4. Cut small illustrations from the advertising pages of mechanical magazines to illustrate parts which have forms based on the following: prisms, cylinders, cones, spheres, and parts of such solids. Paste these on your sheet, indicate type forms and letter the name of each one. If you know the technical name for the parts, letter it underneath the name of the geometrical solid.

EXERCISE 3. — Observe the general proportion of the sheet used for each sketch. At A and B sketch the open and closed belts for the pulleys. At C, D, and E, sketch, respectively, the hexagon, octagon, and pentagon. Approximating the constructions used for drawing the polygons with

drawing instruments will aid in obtaining well-proportioned forms. For the hexagon at C, 60° lines through the center of a circle will locate points on the hexagon. The radius used as a chord will divide a circle into six equal parts. For the octagon at D, sketch a square. Then use one half the diagonal as a radius with centers at the corners to draw arcs to locate points on the octagon. For the pentagon at E, draw a semicircle with a radius equal to one side of the pentagon and divide it into five equal parts. Draw lines from o through each division. Then with the same radius draw an arc intersecting the first line from o at b. Line ab is one side of the pentagon. Locate point c by an arc from center b. Locate point d by an arc from c. At F, sketch an ellipse. Points on an ellipse can be located by using a strip of paper, called a trammel. On a strip of paper lay off the distances oa and oc (one half the major axis and one half the minor axis), Plate 14 at F. By moving the trammel so that point c is kept on the major axis (ab) and point a is kept on the minor axis (cd), marks made opposite point o will locate points on the ellipse. Indicate the foci by making $df_1 = df_2 = oa$.

At G, sketch an oval. At H, sketch the radiating lines from o making the following angles with aa: ob at 30° , oc at 60° , od at 15° , oe at 45° , of at 75° .

EXERCISE 4. — This plate is for practice in blocking in and sketching an isometric ellipse (see Chap. 8). The construction is shown in six steps from A to F. At A, a diamond has been sketched, the sides of which make 30° degrees with a horizontal line. Locate b and d at centers of lines af and cf and draw lines ab and cd. At B, sketch long horizontal line fif and locate g midway between e and f. At C, locate h midway between g and f and lay off gihi equal to $gh = hf$. Points g and hi must be accurately placed in order to secure a fair isometric ellipse. A short arc through g and a long arc through hi will form part of the ellipse as at D and E. The left hand part is worked in the same manner and the completed ellipse is shown at F.

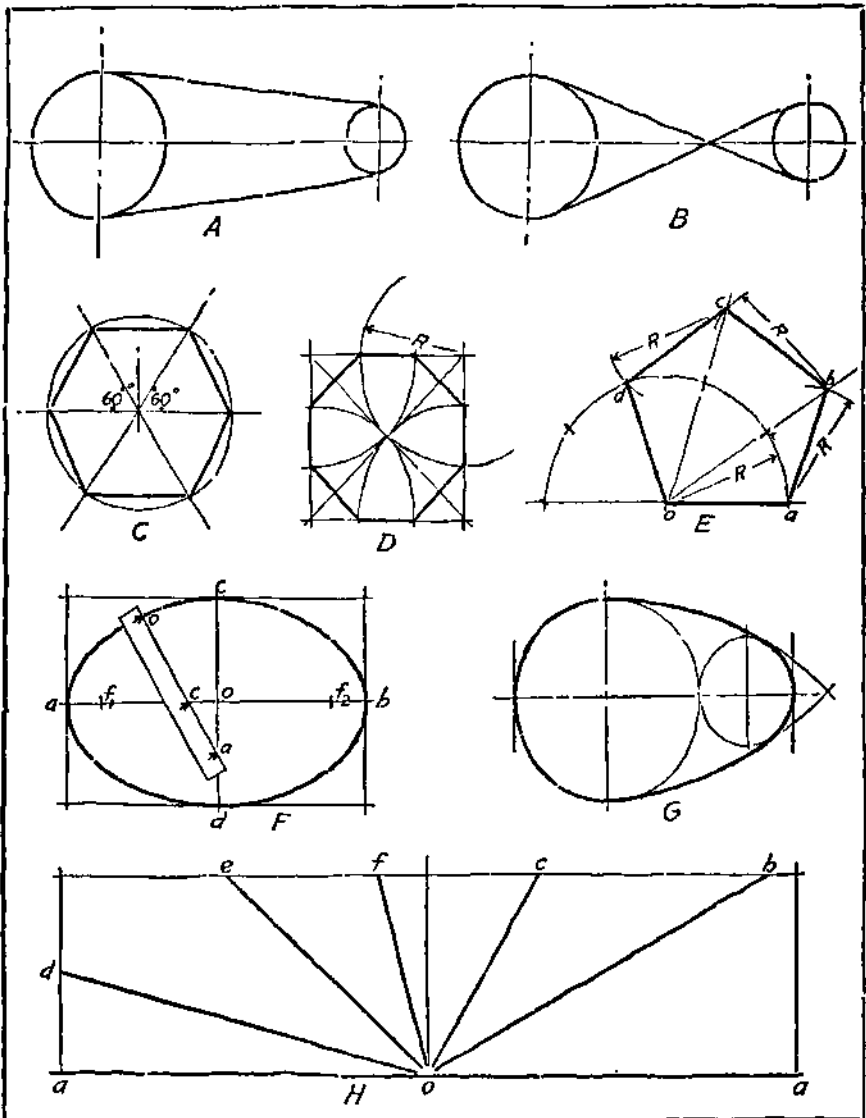

EXERCISE 3.

NAME

DATE

SHEET NO.

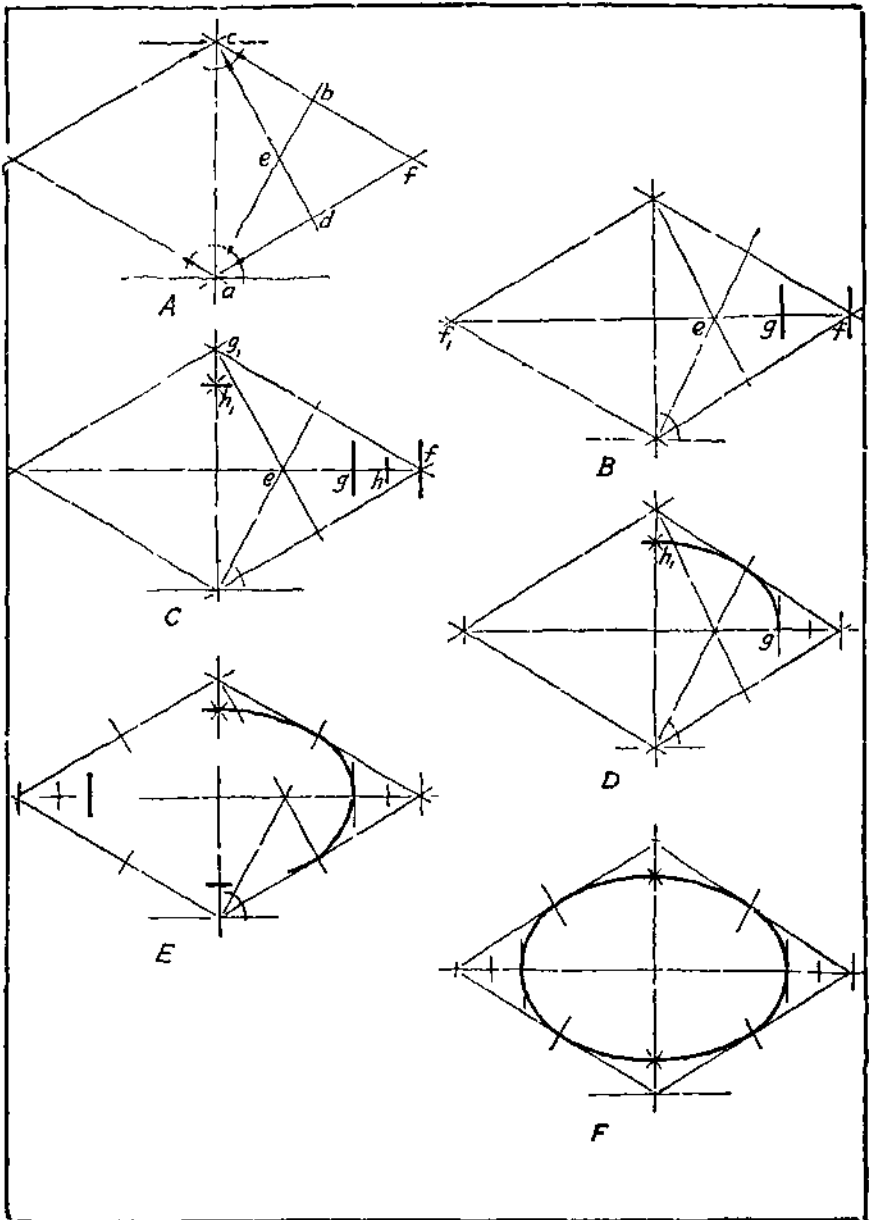

PLATE 15. Geometrical Construction.

MEMORANDA

5

PRINCIPLES OF PROJECTION

MEMORANDA

5

PRINCIPLES OF PROJECTION

Methods of Representation. — Machines, buildings, ships, airplanes, and engineering constructions generally, have to be designed and represented by drawings before they can be manufactured or built. Various methods of making drawings are in use such as perspective, isometric, oblique, and orthographic projection.

Each method has certain advantages but the use of orthographic projection for industrial purposes is universal. The other methods while more pictorial have limitations which unfit them for general use in the planning and construction of engineering work.

A perspective drawing shows a machine or structure as it appears to the eye. If a square or oblong building is viewed from a high position it will appear to be narrower and shorter at the back than in front. A photograph or perspective of the building would be of value in conveying information as to its style, character, etc., but could not be used for giving the dimensions necessary for construction. This is because parts which actually are the same size appear to be different sizes depending upon how far they are from the observer.

The pictorial feature of perspective can be retained in the more practical forms of drawing such as isometric and oblique. In these, equal distances on the real construction are made equal distances on the drawing. Compare the different kinds of representation as shown on Plate 16. In the perspective, receding lines converge while in isometric or oblique they remain parallel. The effect is not as pleasing but such drawings are more easily made and used.

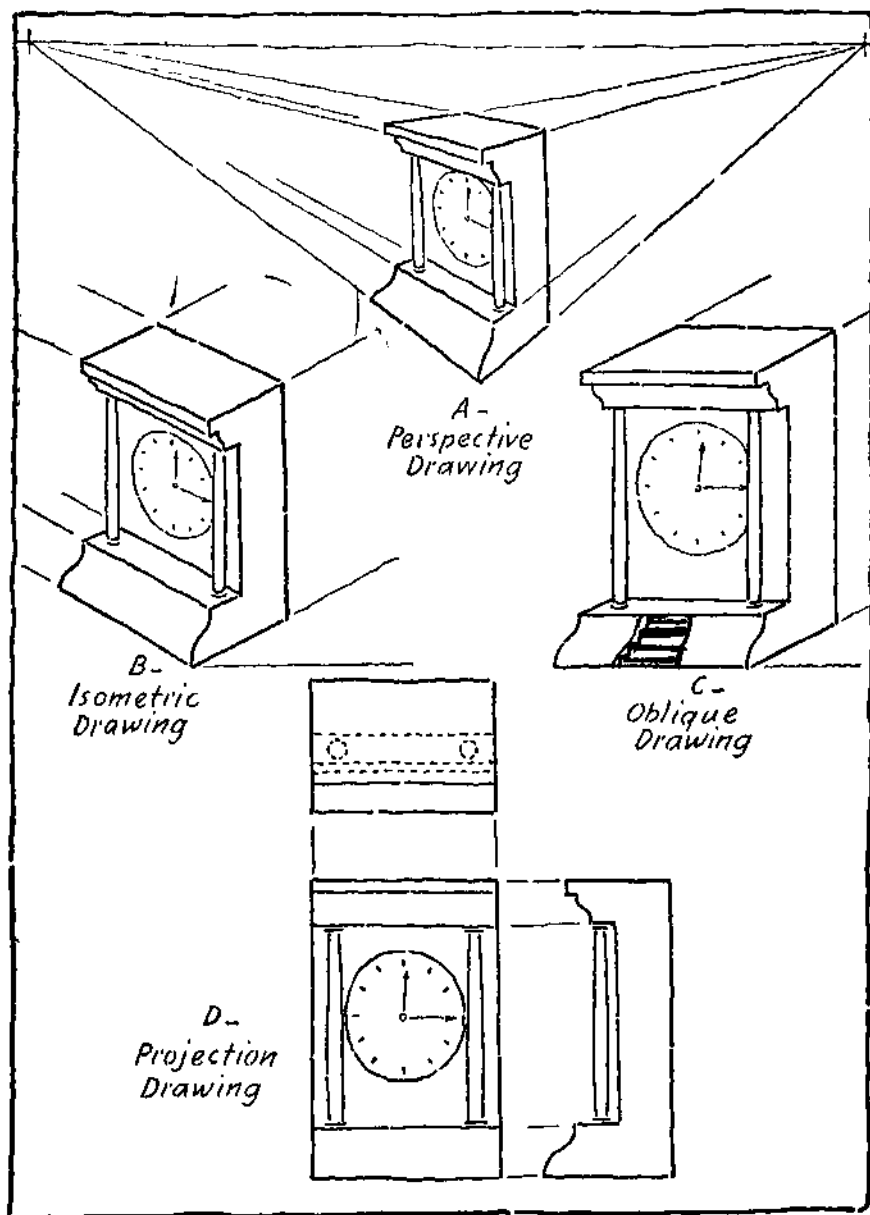

PLATE 16 Different Kinds of Drawings.

Working Drawings.—Working drawings are drawings which give directions for doing work. They must show the exact shapes and give dimensions or sizes. For this purpose views obtained by orthographic projection are used. Generally these consist of front, side and top views. It will be necessary to understand just how such views are obtained in order to make drawings or sketches and to read shapes from shop drawings and blueprints.

The Planes of Projection.—In order to study the obtaining of views and their relation to each other, imagine three glass planes joined by hinges and forming one corner of a box, Plate 17.

Place the object within the box. The top, front, and side views can be drawn in their correct positions by tracing the outline and details on the three glass planes as shown. This will give top, front, and side views. Lines from the object, perpendicular to the planes, will intersect the planes and form the views. Such lines are called projection lines. When the box is opened the three views will be on a single flat surface. The complete drawing is shown at E with the views in their proper relation to each other. Note that the length appears on the front and top views, the height appears on the front and side views and the breadth on the top and side views.

The top view is sometimes called a plan, the front and side views are sometimes called the front elevation and side elevation.

The projection box is, of course, not practical for everyday use in making drawings or sketches. It is essential, however, to remember how the planes open and to always place the views in their correct positions.

Representation of Hidden Surfaces. — Parts which cannot be seen when viewing an object from a given position must be represented in order to completely describe the shape of the object. Such parts are projected to the planes in the same way as the visible parts, but they are represented by "hidden" lines composed of short dashes. See the top view of the clock on Plate 16. The front and side views do not tell the shape of the two uprights. The hidden

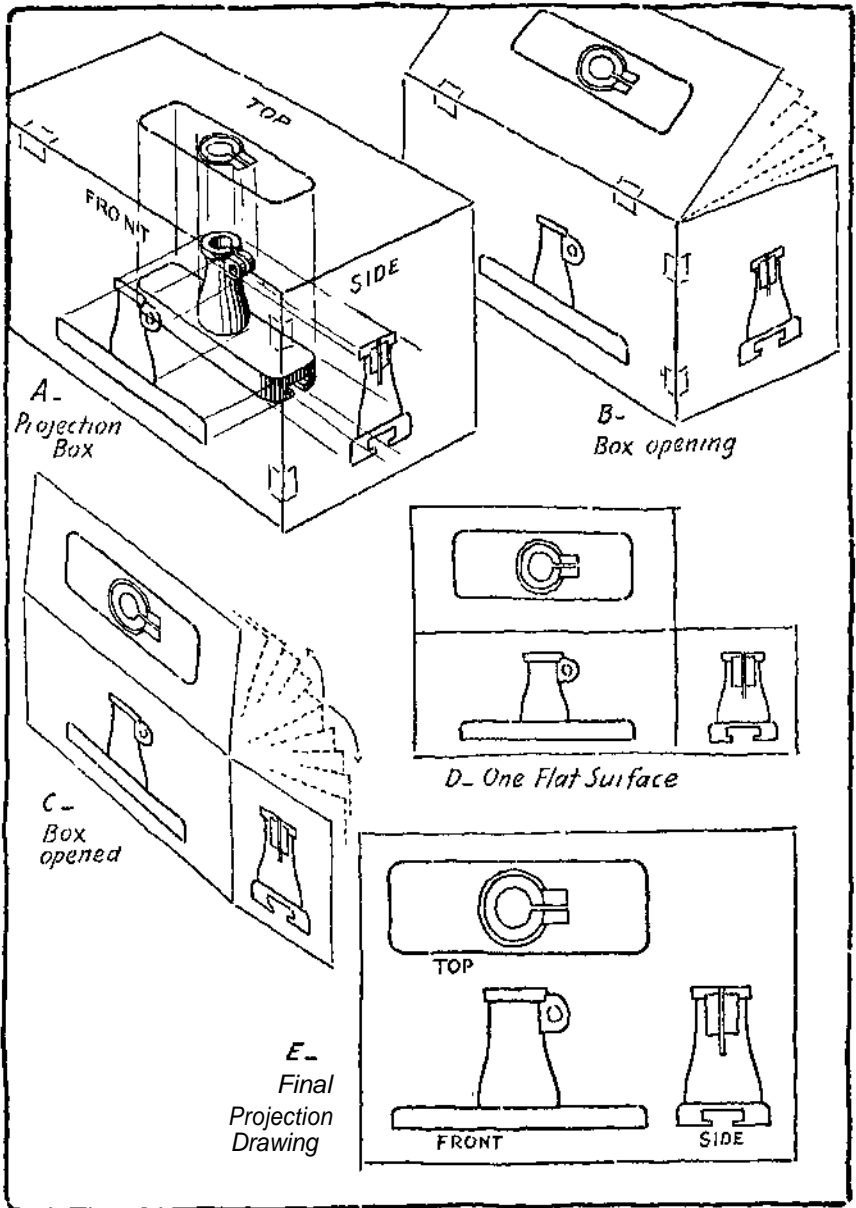

PLATE 17. "The Projection Box."

circles in the top are required to complete the description. On Plate 20 the surface of the groove is shown on the side view by a dotted line because it is hidden.

Obtaining Views from a Model. — If the front view is drawn first the other views may be obtained by considering a model (real or imaginary) to be turned as the planes are turned. This is illustrated on Plates 18 to 22. Notice how the object is placed in position to obtain the front view, marked first position at A. The object is then turned so that the top of it can be seen and moved up directly above the first position into the second position, at B. Next consider the object to be returned to the first position and turn it so that the right side can be seen and move it directly to the right of the first position, as at C. The three views will then appear as at D. A little practice in placing actual parts or models in the positions described will help fix the principles of projection so that the views can be correctly drawn and correctly located.

Proportion. — Three fundamentals are necessary to make an acceptable sketch:

First. Good line work (both straight and curved).

Second. Correct projection.

Third. Good proportion.

Good line work comes from practice. Correct projection is necessary to show the shape and to permit the views to be read easily. If any one of these three fundamentals is faulty, the sketch is poor and may be incorrect.

A good sketch may be described by the rule: good lines plus correct projection plus accurate proportion. See A, B and C on Plate 34.

Proportioning and Estimating Measurements. — A satisfactory degree of accuracy in judging the dimensions of an object in order to draw well-proportioned views can soon be acquired by constant practice. Exercises in estimating dimensions by eye should be done repeatedly. For the first few times actual measurements may be

checked with a scale after which the eye alone should be depended upon.

For example, consider a model under inspection: Eye judgment says that it is 4 inches long, that its width is a trifle more than half its length, and that its thickness is slightly less than one quarter of its length. See D on Plate 34. Objects with large dimensions can be proportioned approximately by the extended arm and pencil method as shown at E on Plate 72.

For practice, try drawing horizontal lines (estimated by eye), one-half inch, one and one-quarter inches, and four inches long. Then sketch vertical lines of the same lengths. See E on Plate 34. When drawing angles of different degrees, a useful method is to sketch an arc for a right angle (90°) and then estimate the proportionate number of degrees on the arc as at C, D, and E on Plate 6. For practice, lay out a right angle with lines $3\frac{1}{2}$ inches long and draw an arc. Then estimate and draw lines for the angles most frequently used by draftsmen — 30° , 45° , and 60° . See Plate 34 at F.

Estimate and divide into the required parts for the magnetic compass, the pedometer, and the gauge shown on Plate 34.

Auxiliary Views. — When an object has a surface at an angle and the true shape cannot be shown on one of the regular planes, an extra or auxiliary view is used. This is illustrated at A on Plate 35. Very often auxiliary views are used to show only the part which is at an angle.

Problems. — The graphical description of shape as taken up in this chapter forms the basis of all industrial drawing. A complete working drawing requires the addition of dimensions to specify sizes and notes to give other information as explained in Chapter 7.

The problems which follow are graded in order of difficulty. The pictorial presentation is used to take the place of actual models. All of the problems need not be worked out but a selection should be made from each group.

Use layout No. 1 or No. 2 of Plate 4 depending upon the size and arrangement of views. Do not copy the pictures but sketch the necessary views by the principles of projection. The dimensions on the pictures will fix the proportions, and should be kept in mind in planning and sketching the views. A sketch, of course, is not to be measured but if way out of proportion it frequently indicates careless thinking and is not as quickly read.

PROBLEMS 1 to 4, PLATE 23. — Simple objects with surfaces parallel to the planes of projection. Sketch the necessary views of each piece on a separate sheet.

PROBLEMS 5 to 12, PLATES 24 and 25. — Simple objects with inclined surfaces.

PROBLEMS 13 to 28, PLATES 26 to 29. — Hollow and indented objects.

PROBLEMS 29 to 40, PLATES 30 to 32. — Objects with cylindrical parts.

PROBLEMS 41 to 44, PLATE 33. — Objects with tangent surfaces.

PLATE 34. — Proportion exercises.

PROBLEMS 45 to 48, PLATE 35. — Auxiliary views.

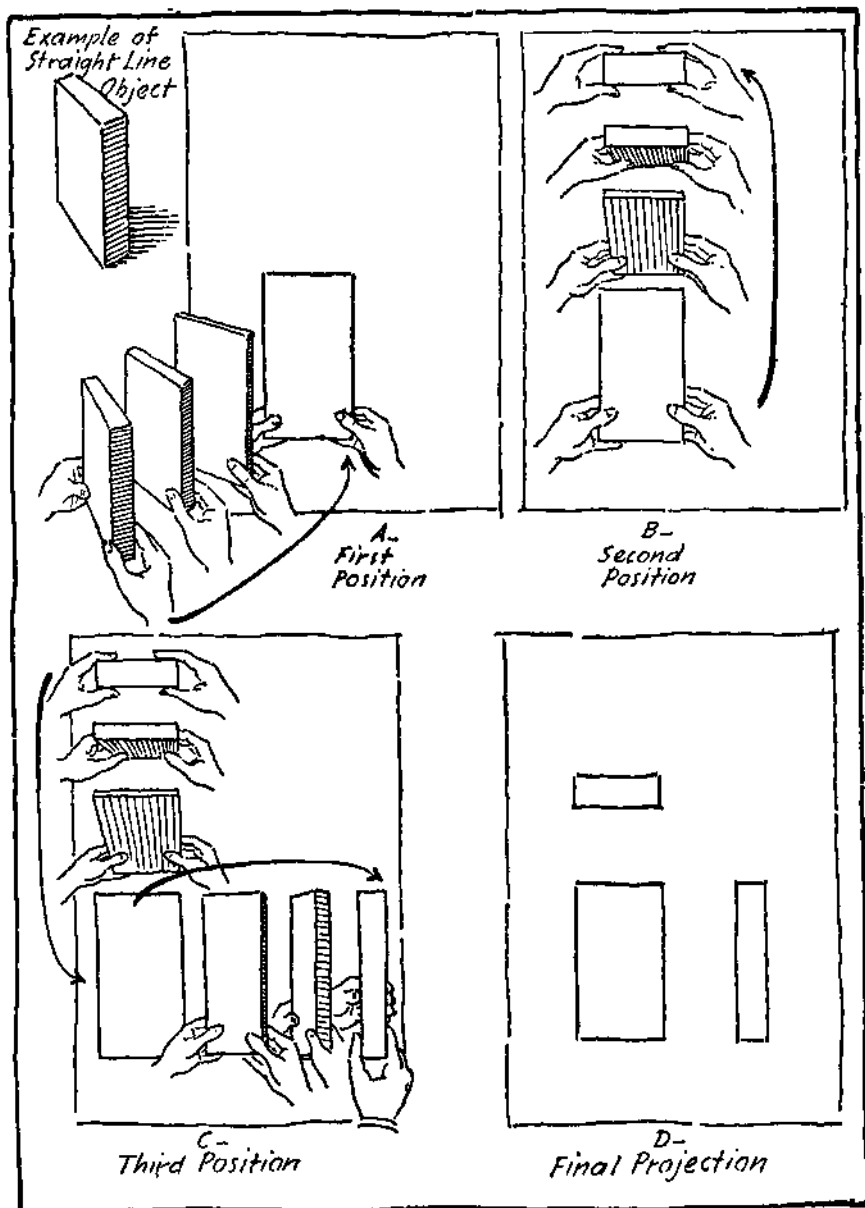

PLATE 18. Obtaining the Views of a Prism.

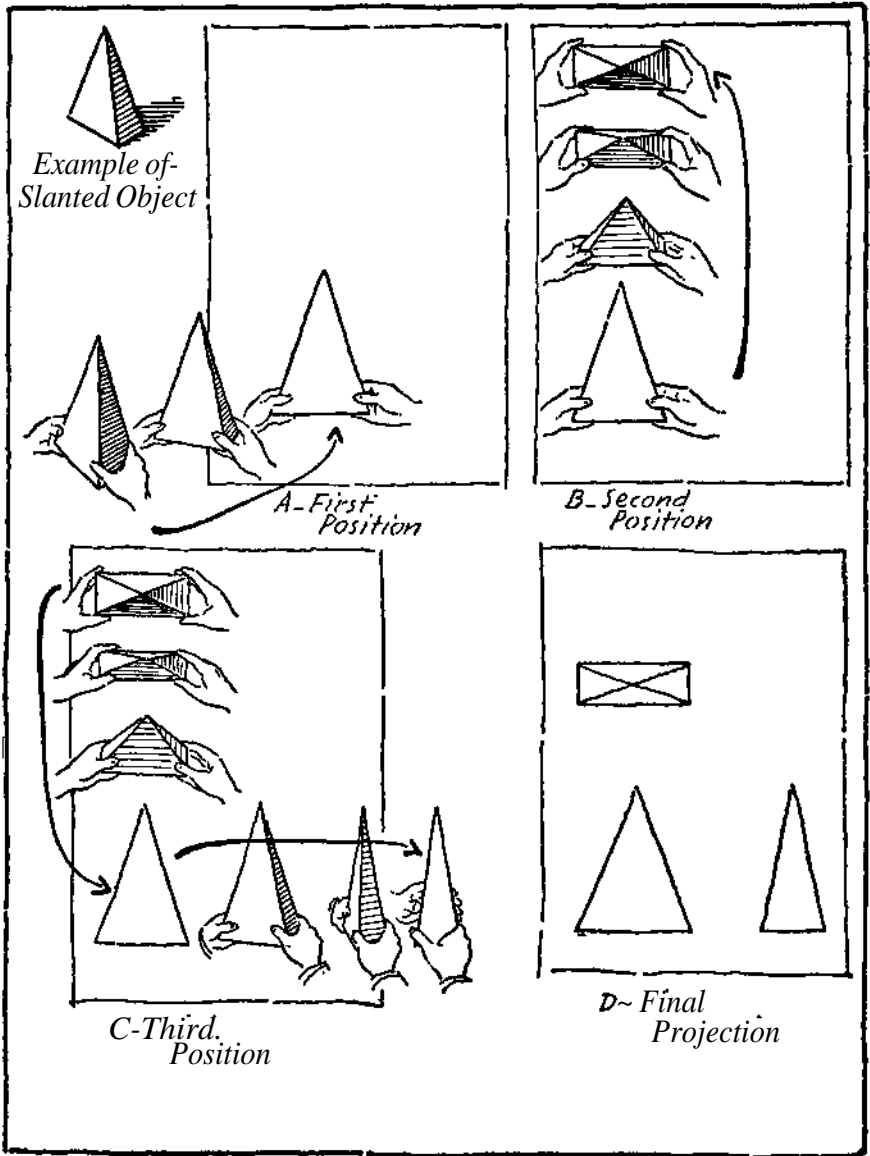

PLATE 19. Obtaining the Views of a Pyramid.

34441

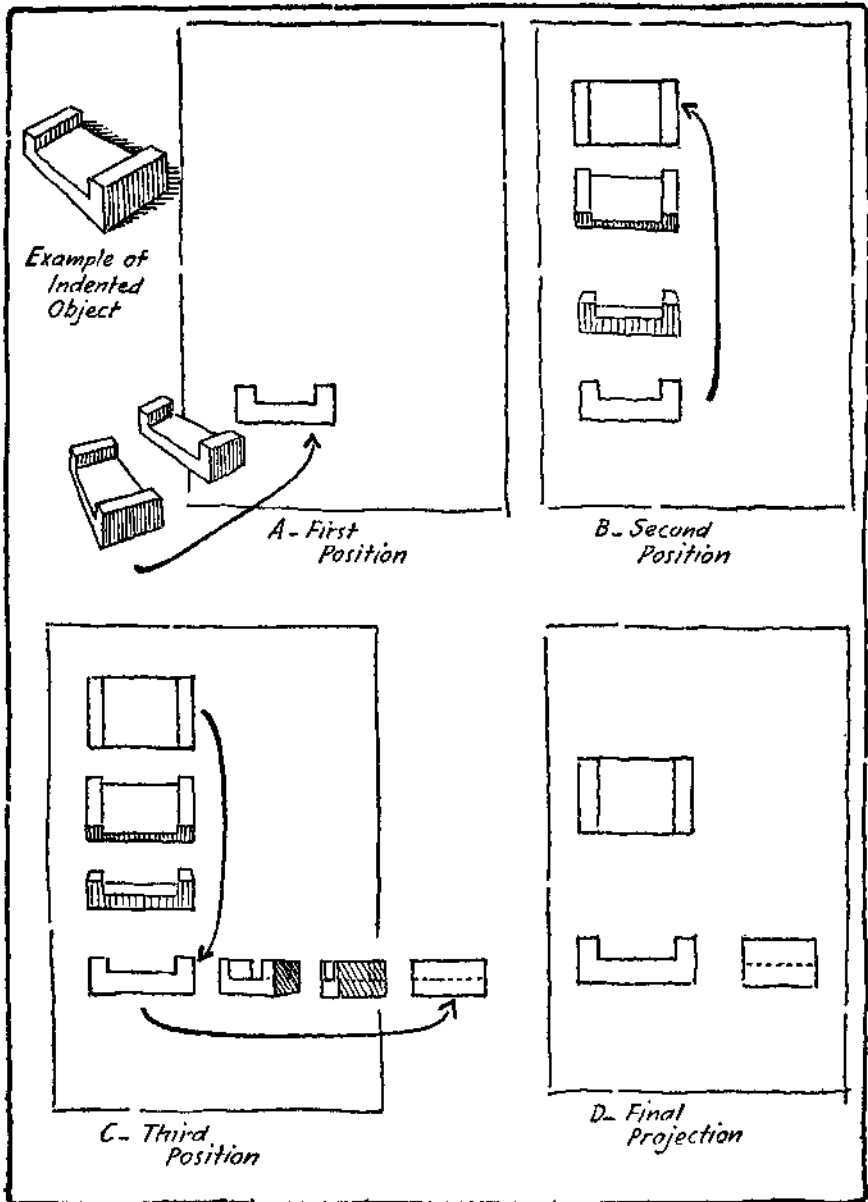

PLATE 20. Obtaining the Views.

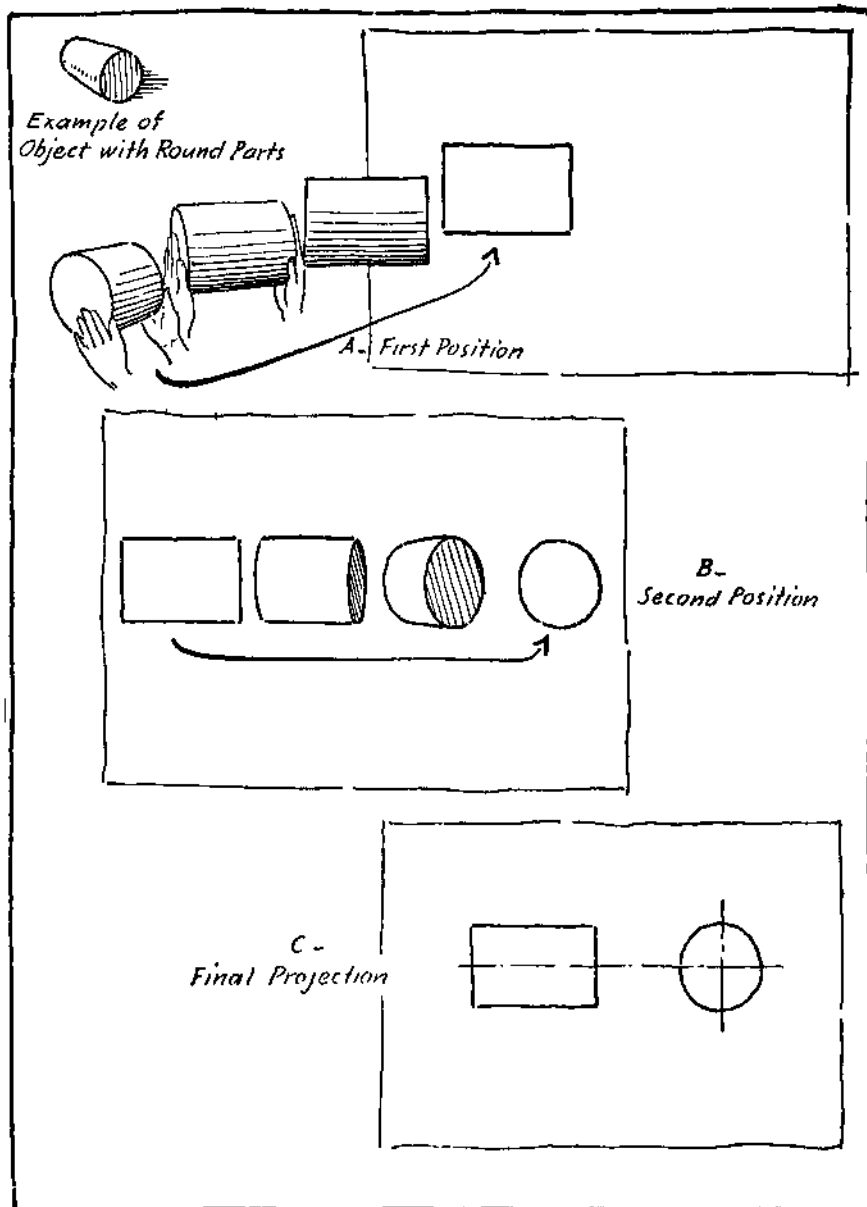

PLATE 21. Obtaining the Views of a Cylinder.

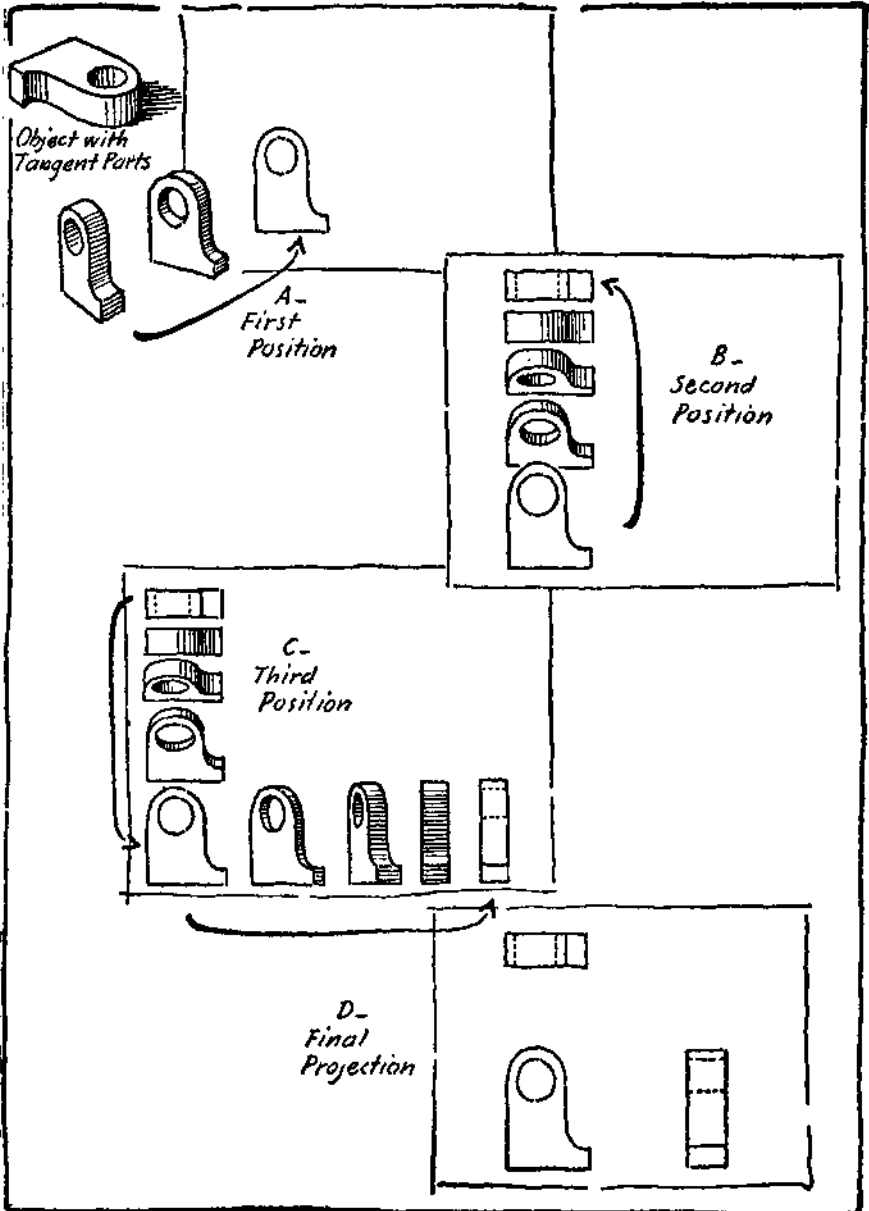

PLATE 22. Obtaining the Views.

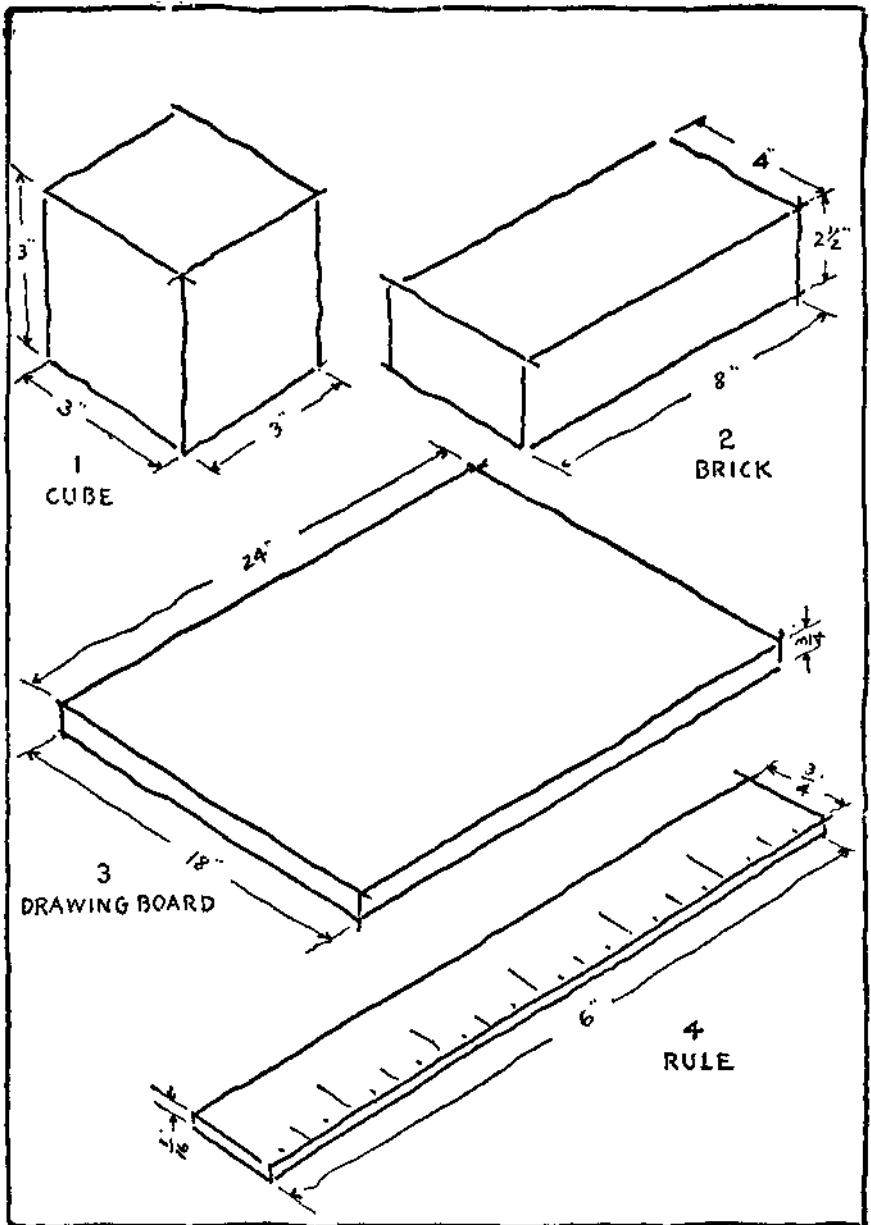

PLATE 23. Problems 1 to 4.

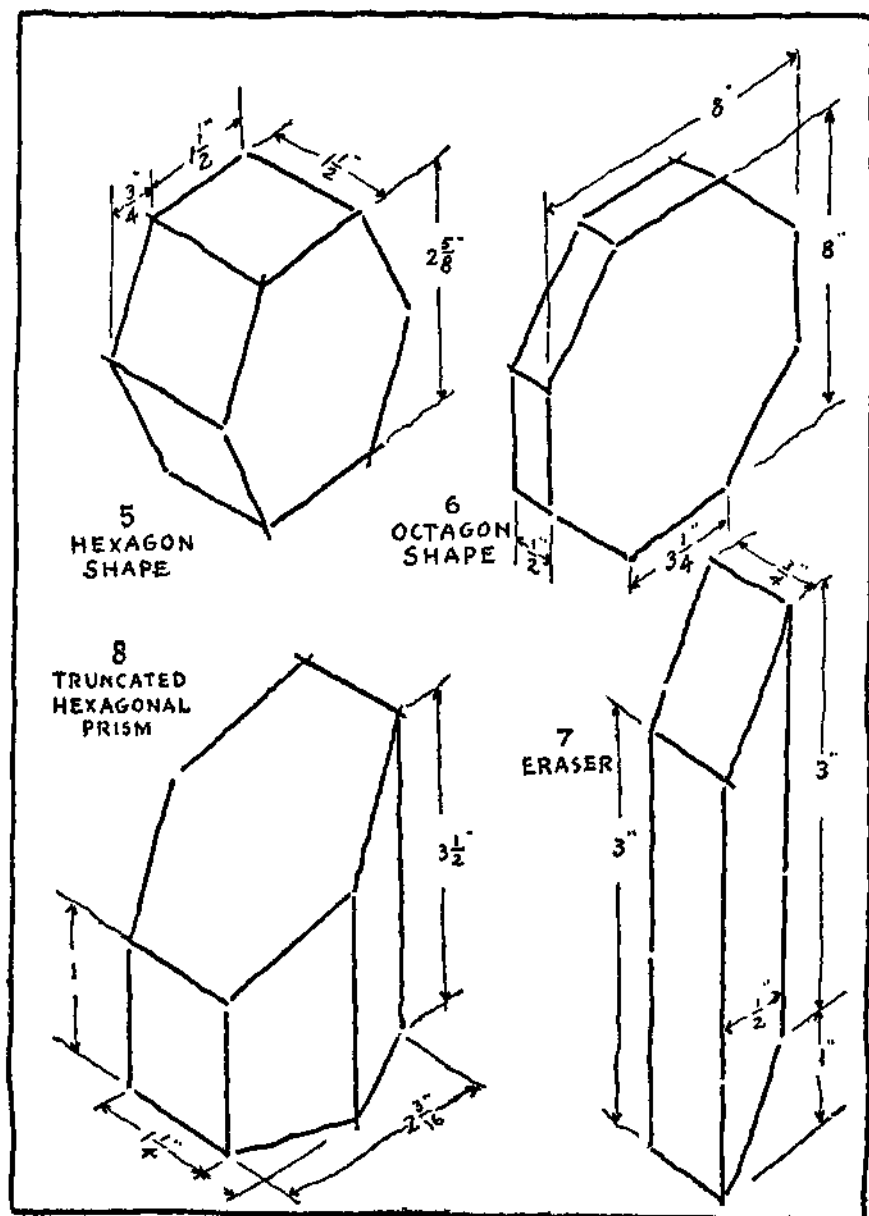

PLATE 24. Problems 5 to 8.

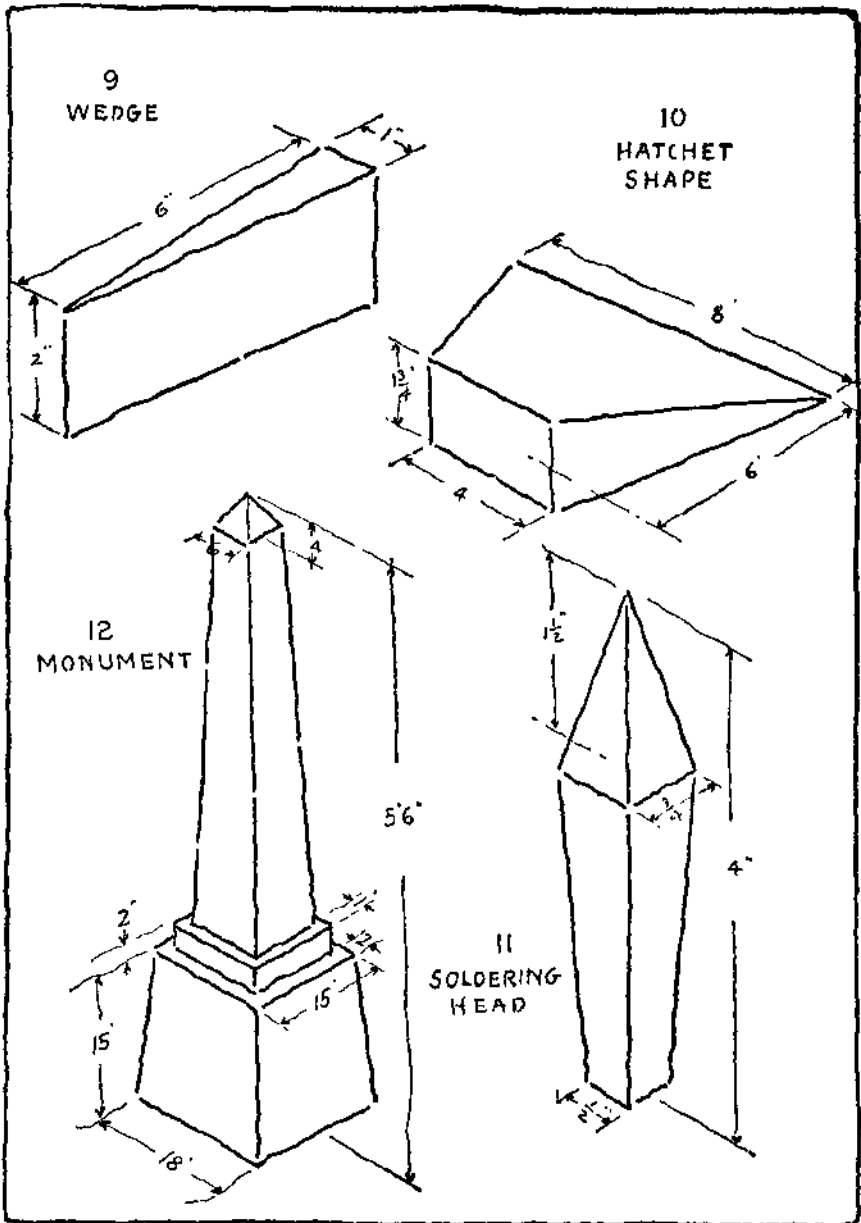

PLATE 25. Problems 9 to 12.

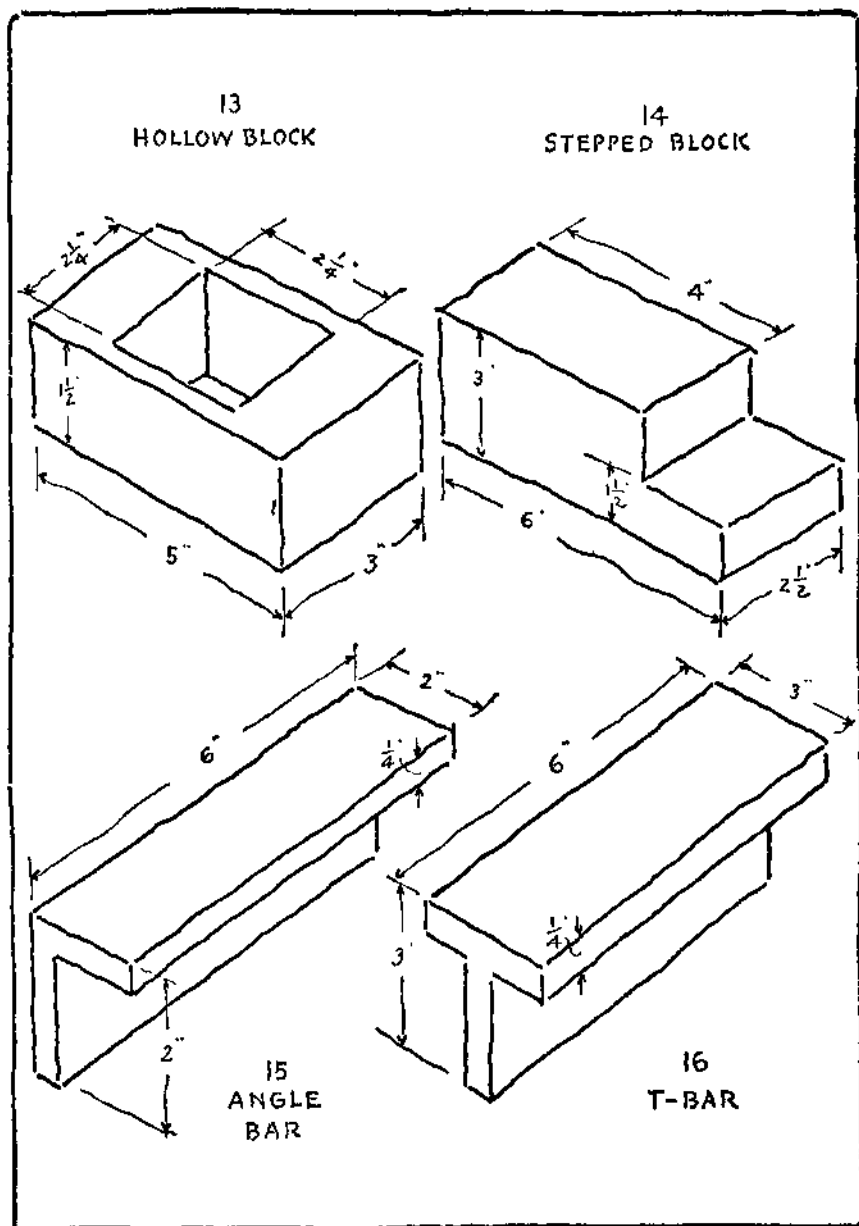

PLATE 26. Problems 13 to 16.

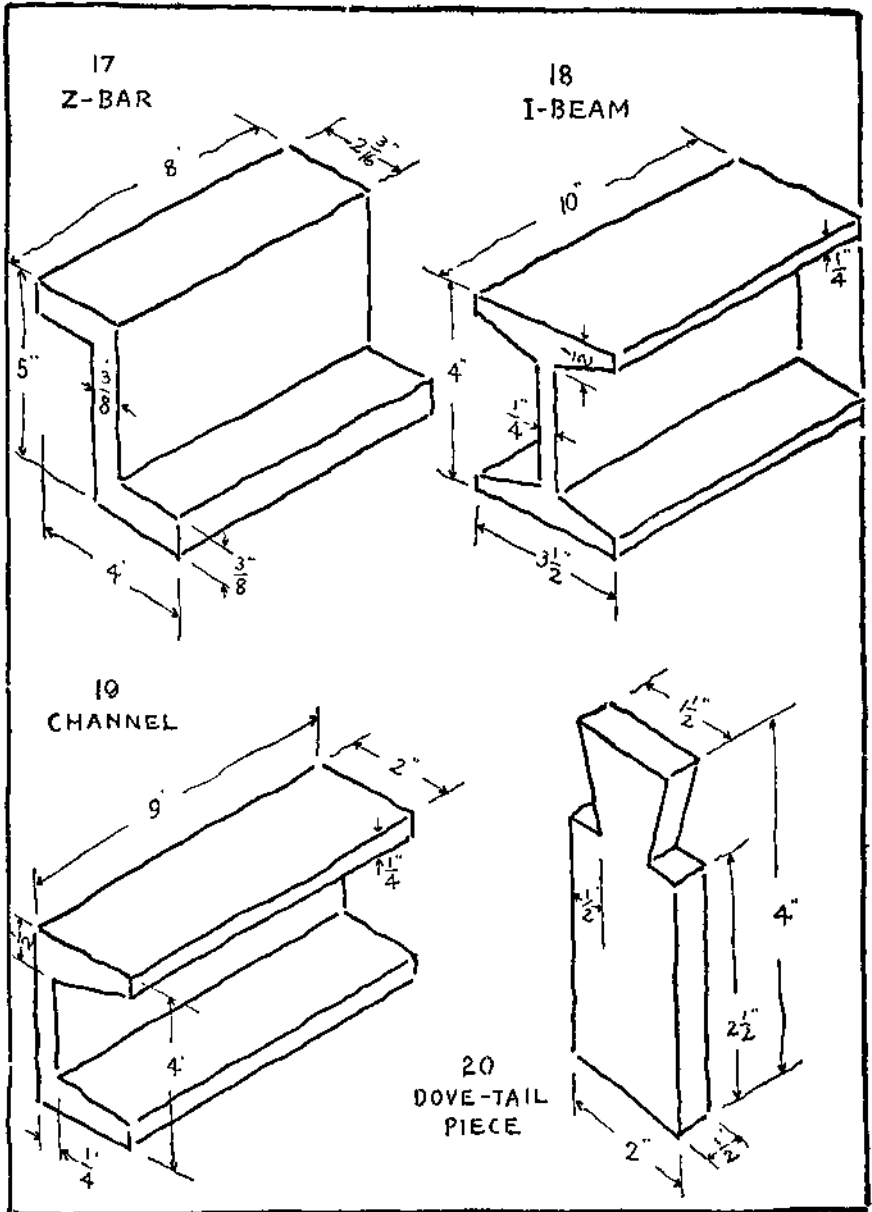

PLATE 27. Problems 17 to 20.

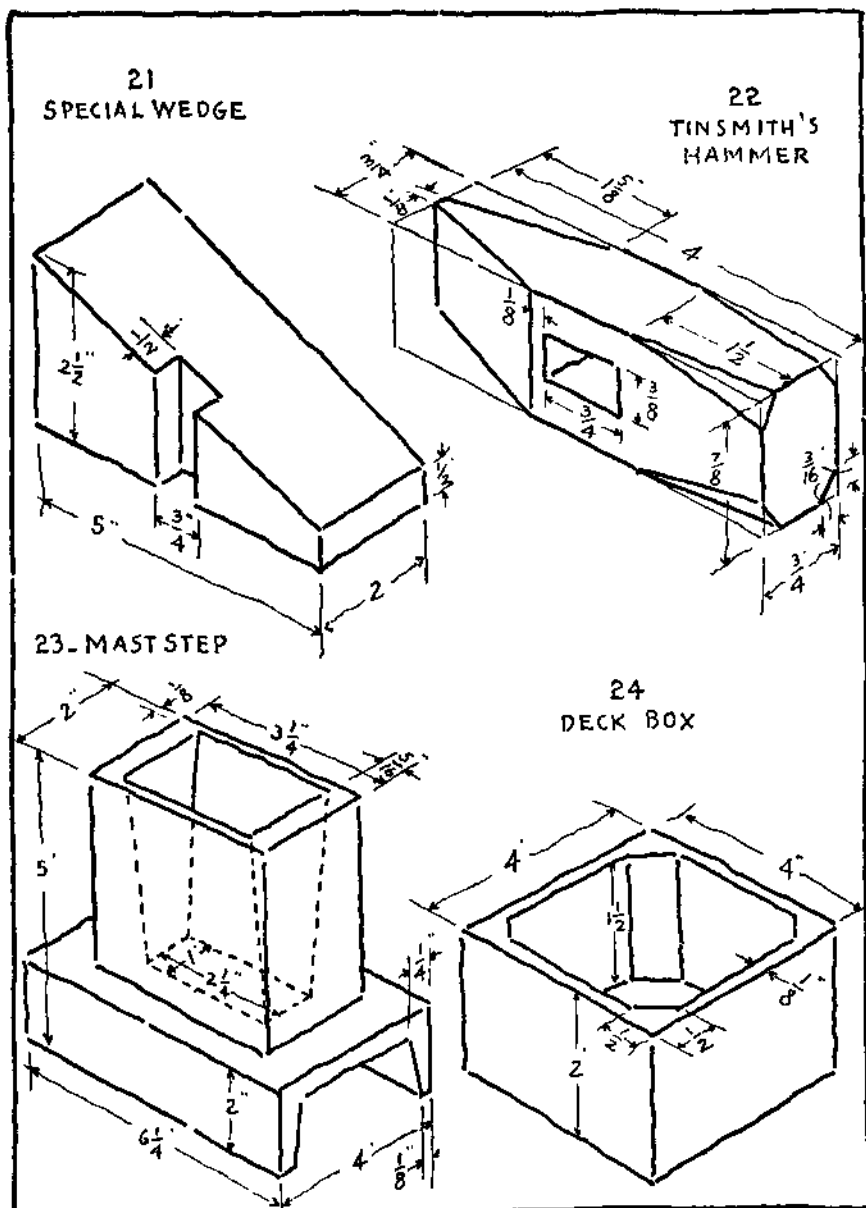

PLATE 28. Problems 21 to 24.

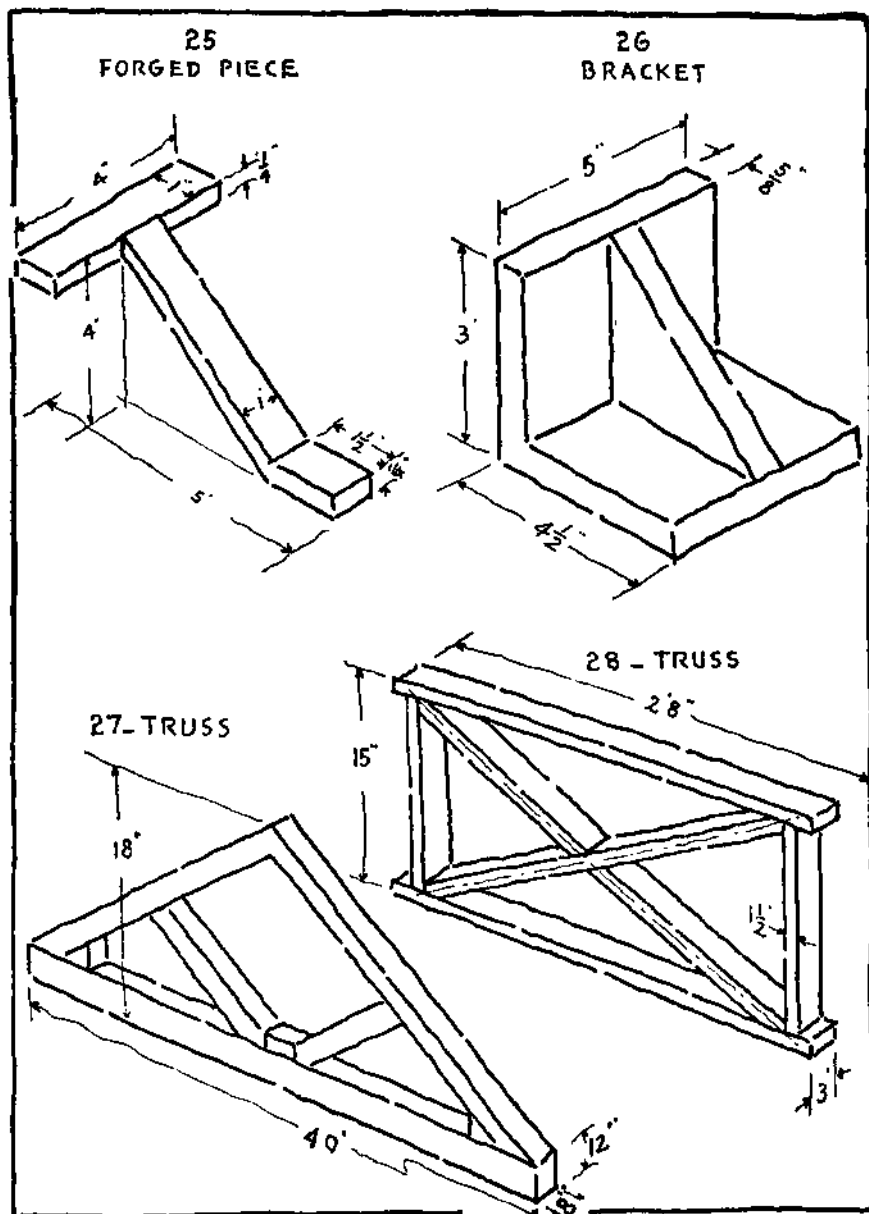

PLATE 29. Problems 25 to 28.

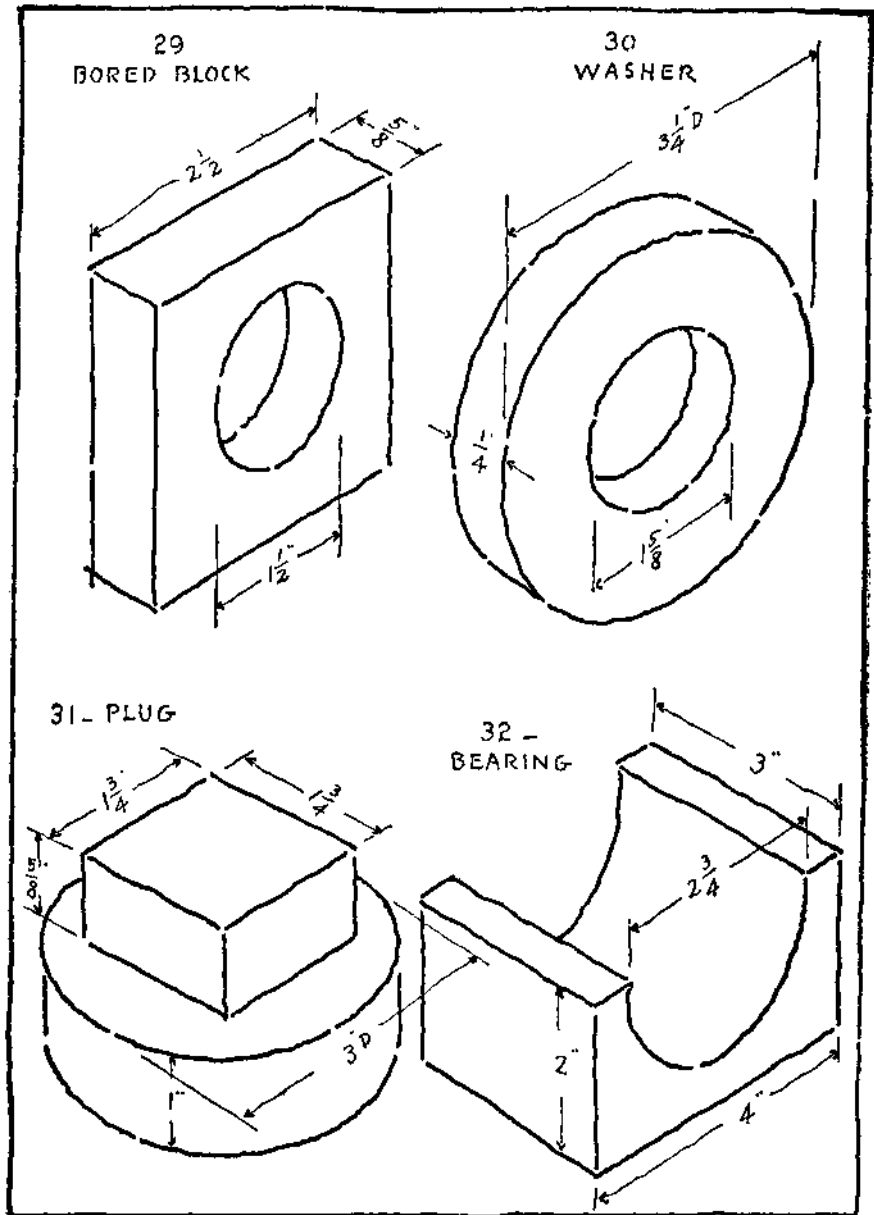

PLATE 30. Problems 29 to 32.

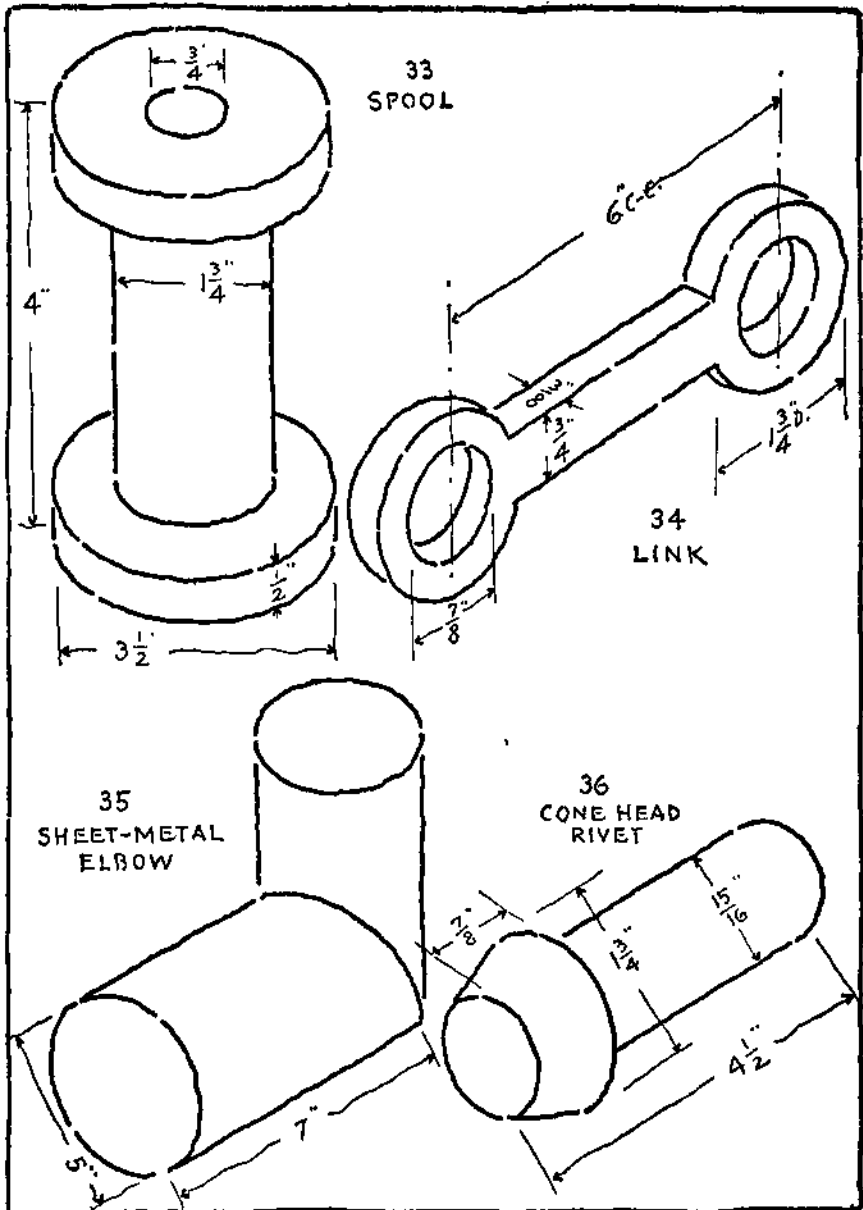

PLATE 31. Problems 33 to 36.

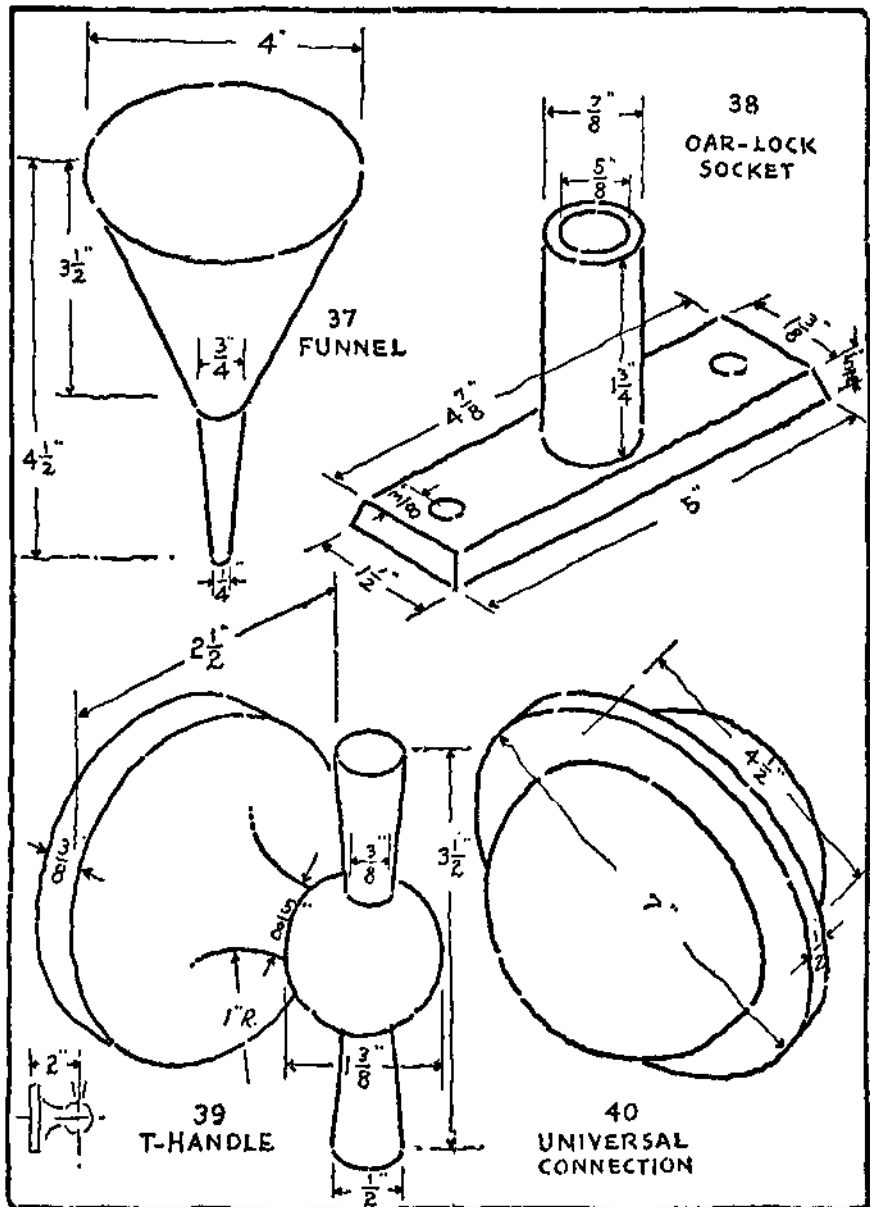

PLATE 32. Problems 37 to 40.

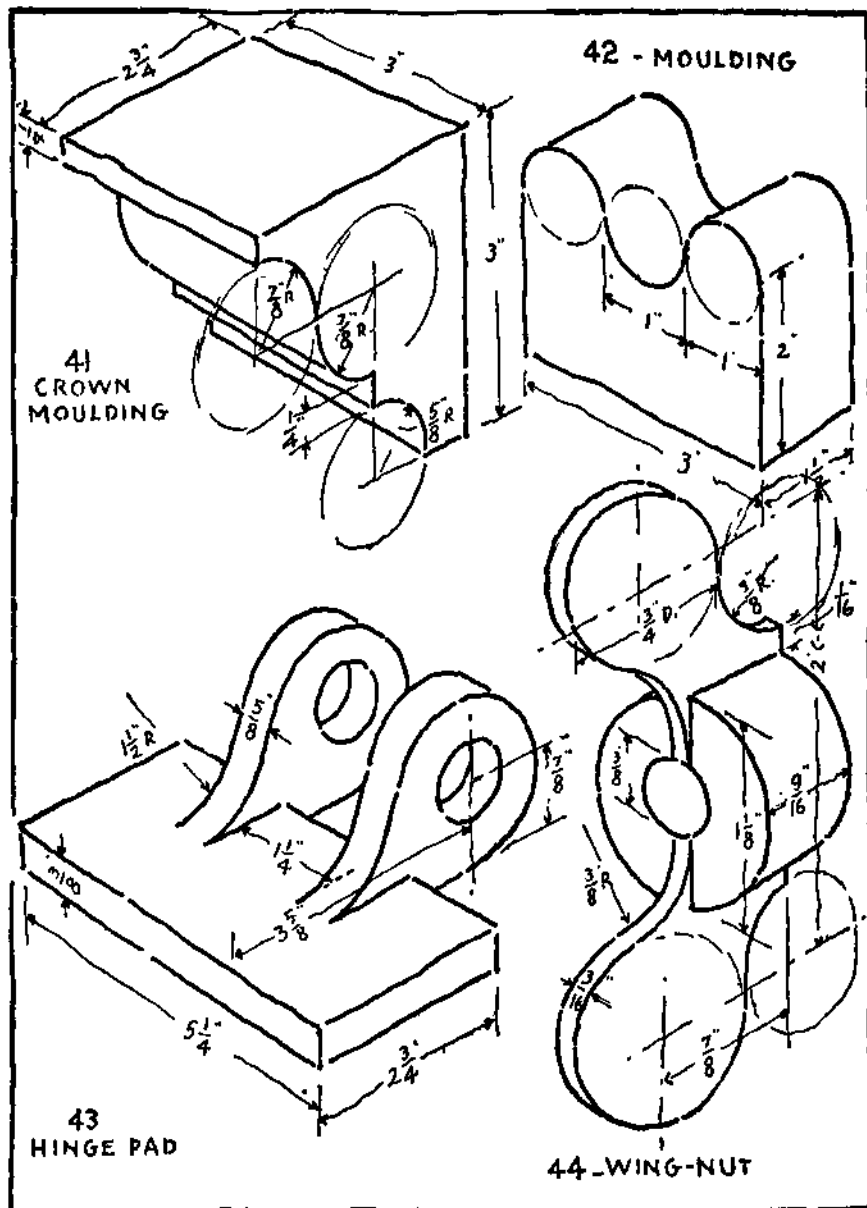

PLATE 33. Problems 41 to 44.

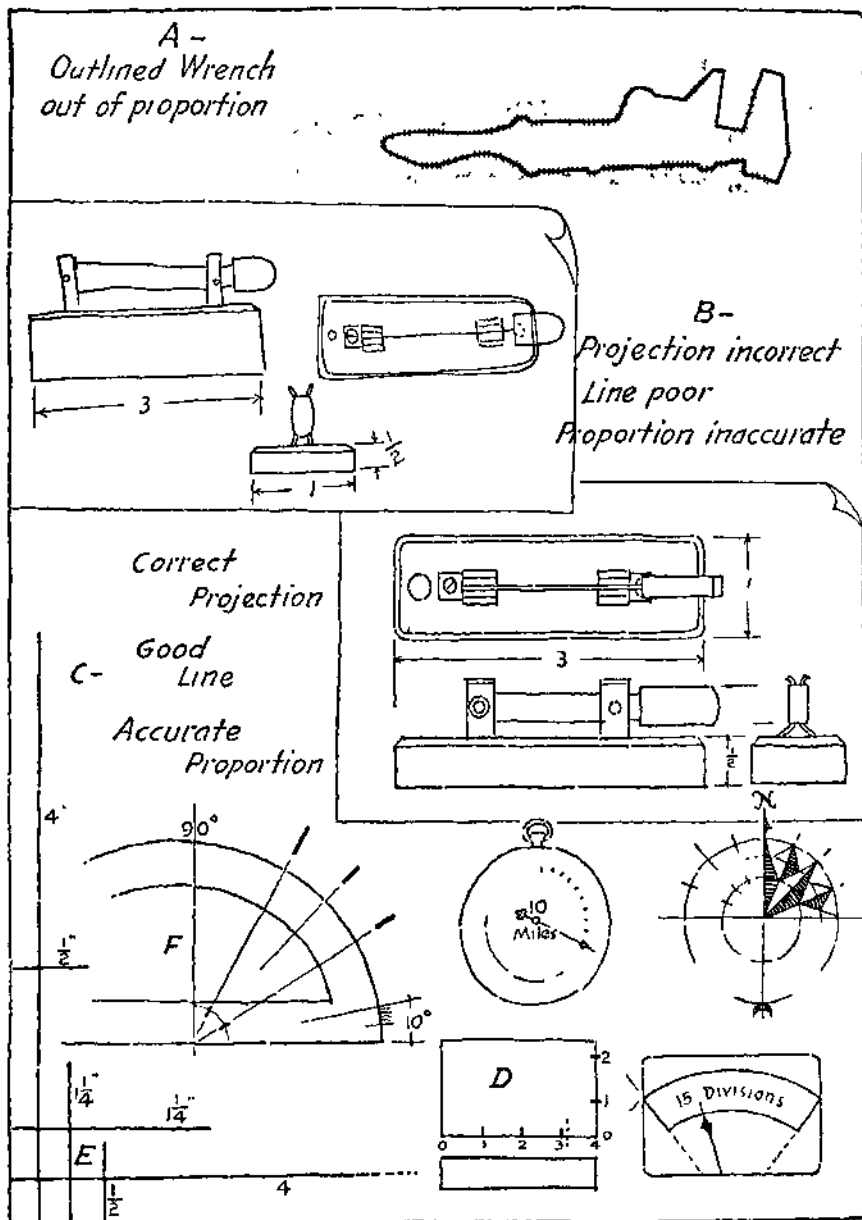

PLATE 34. Proportion Exercises.

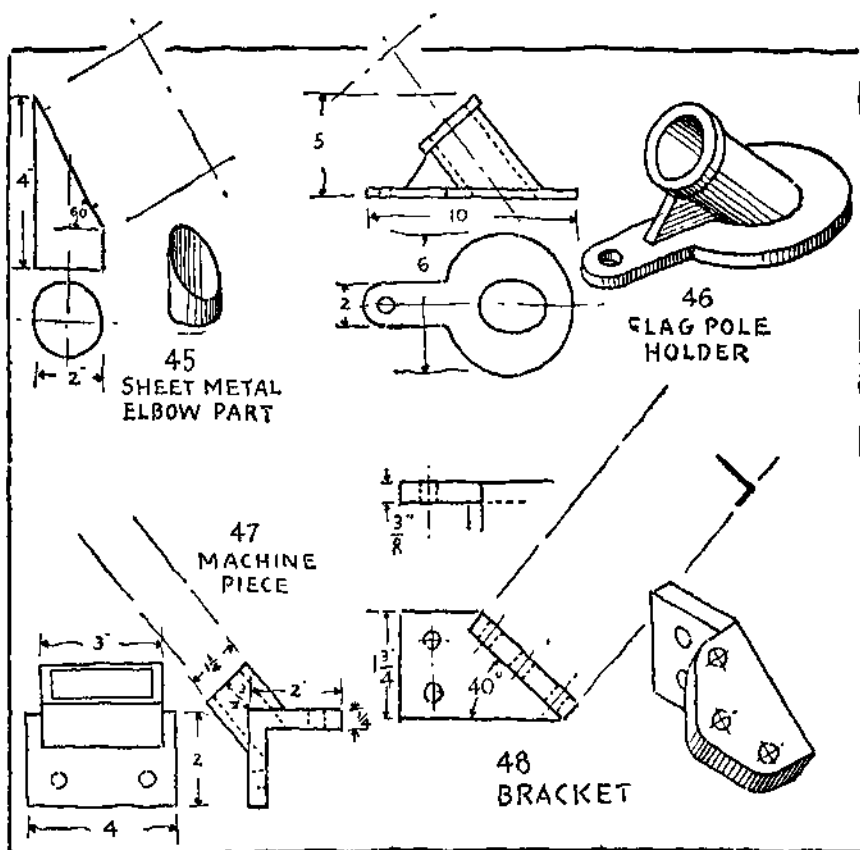
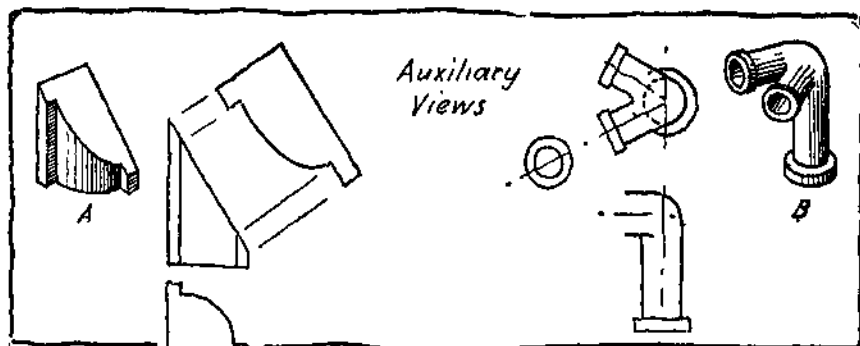

PLATE 35. Problems 45 to 48.

MEMORANDA

6

SECTIONAL VIEWS

MEMORANDA

6

SECTIONAL VIEWS

Representation of Interior Construction. — In the previous chapter interior or hidden constructions were shown by dotted lines. The character or amount of construction to be represented often makes such drawings hard to read. In such cases a method called sectioning is generally used.

Principle of the Sectional View. — This principle is illustrated at A on Plate 36 by the draftsman's wood ink bottle holder. Such an object could be clearly described by using dotted lines but it is used here for comparison. Imagine the object to be cut or sawed in two and the front part removed so that the hole is visible as shown in the picture. Views made to conform with this principle are given at B. The top view shows the position of an imaginary cutting plane and the front view shows the cut surface and the interior detail. The cut surface is indicated by a series of parallel lines drawn at an angle, generally 45° . The view is called a section or sectional view and the parallel lines are called section lines, sectioning or cross-hatching. The top view is shown complete because the cutting plane is only an imaginary one used to locate the sectional view.

The Imaginary Cutting Plane. — The principle of the sectional view makes use of an imaginary cutting plane. The part of the construction in front of the plane is removed and the cut surface and remaining parts are then drawn as they would appear.

The position of the cutting plane should be shown on one of the other views by a distinguishing line as illustrated. Sometimes arrows are added to indicate the direction in which the plane is viewed, especially when part or extra sections are made. When

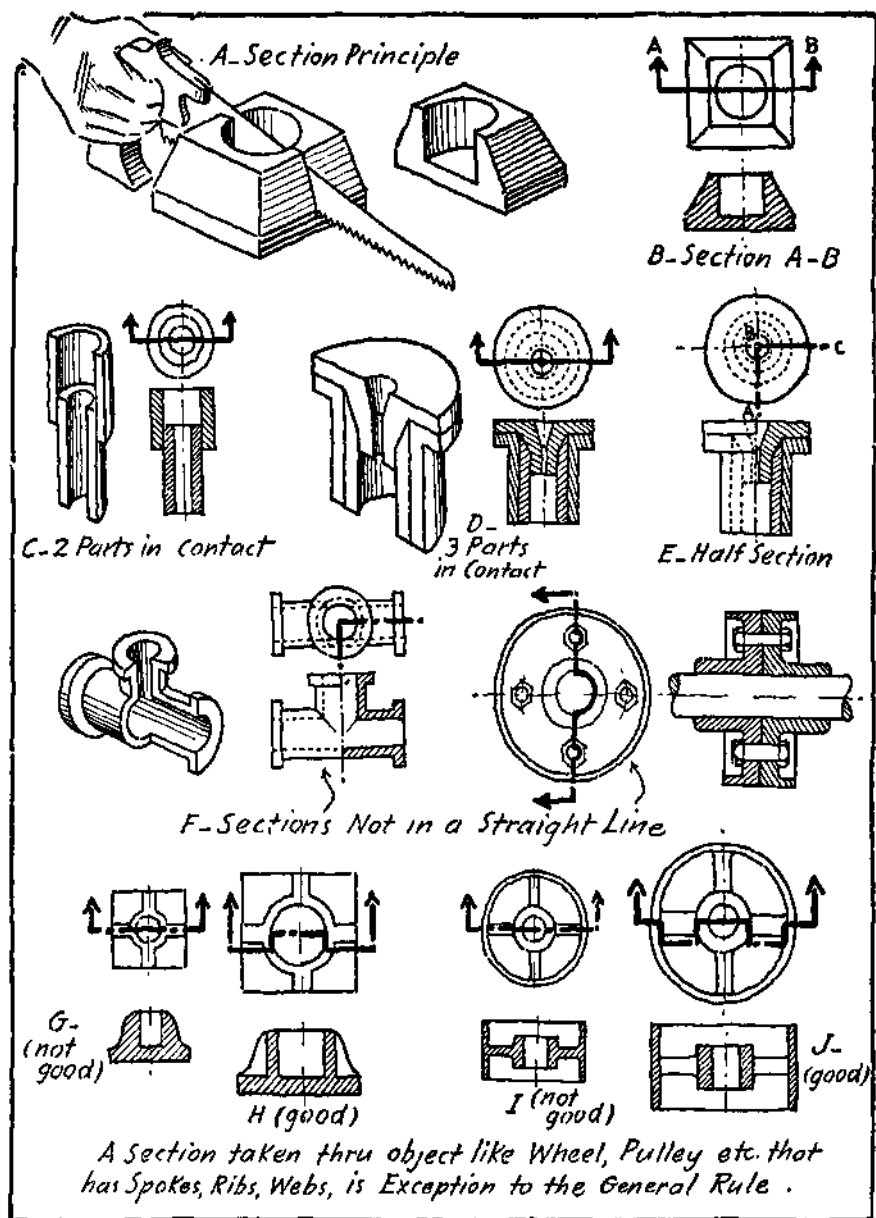

PLATE 36. Sectional View Studies.

the section is evidently through the center neither the cutting plane nor the arrows are necessary.

Kinds of Sectional Views. — When two pieces are cut by a plane they are sectioned in opposite directions, Plate 36, at C. As mentioned before the 45° slope is generally used but when more than two pieces are shown, 30° or 60° lines may be used, Plate 36, at D. The dotted lines representing invisible features beyond the cutting plane are often omitted especially if they confuse rather than help in the shape description. However, when they are necessary to show details or construction they must be used.

When an object is symmetrical, both the interior and exterior may be shown by a view which is half section and half elevation as at E and F, Plate 36. Such a view is called a half section, and is obtained by using two imaginary cutting planes.

Other terms which occur in sectional treatment are Longitudinal Section, Transverse or Cross Section, and Horizontal Section. A ship, cut through from bow to stern would be represented as a longitudinal section; if cut at right angles to this, by a transverse section; and if cut parallel to the deck, by a horizontal section.

Treatment of Shafts, Bolts, Etc. — Shafts, spindles, bolts, screws, and other small solid parts are not shown in section. When they are part of a construction that is sectioned the cutting plane is imagined to pass around the curved surface. This allows such pieces to be shown as at F on Plate 36.

Exceptions to the Rule of Sectioning. — The previous article shows that it is not always necessary to cut straight through an object. There are conditions where a true section might be misleading. In such cases the cutting plane can be arranged to give a better representation. The section of the sod tamper at G, Plate 36 does not give as good a description as when the cutting plane is taken to give the sectional view at H.

The four-arm pulley appears to be webbed at I, while the treatment at J gives a correct impression. It is not necessary to indicate

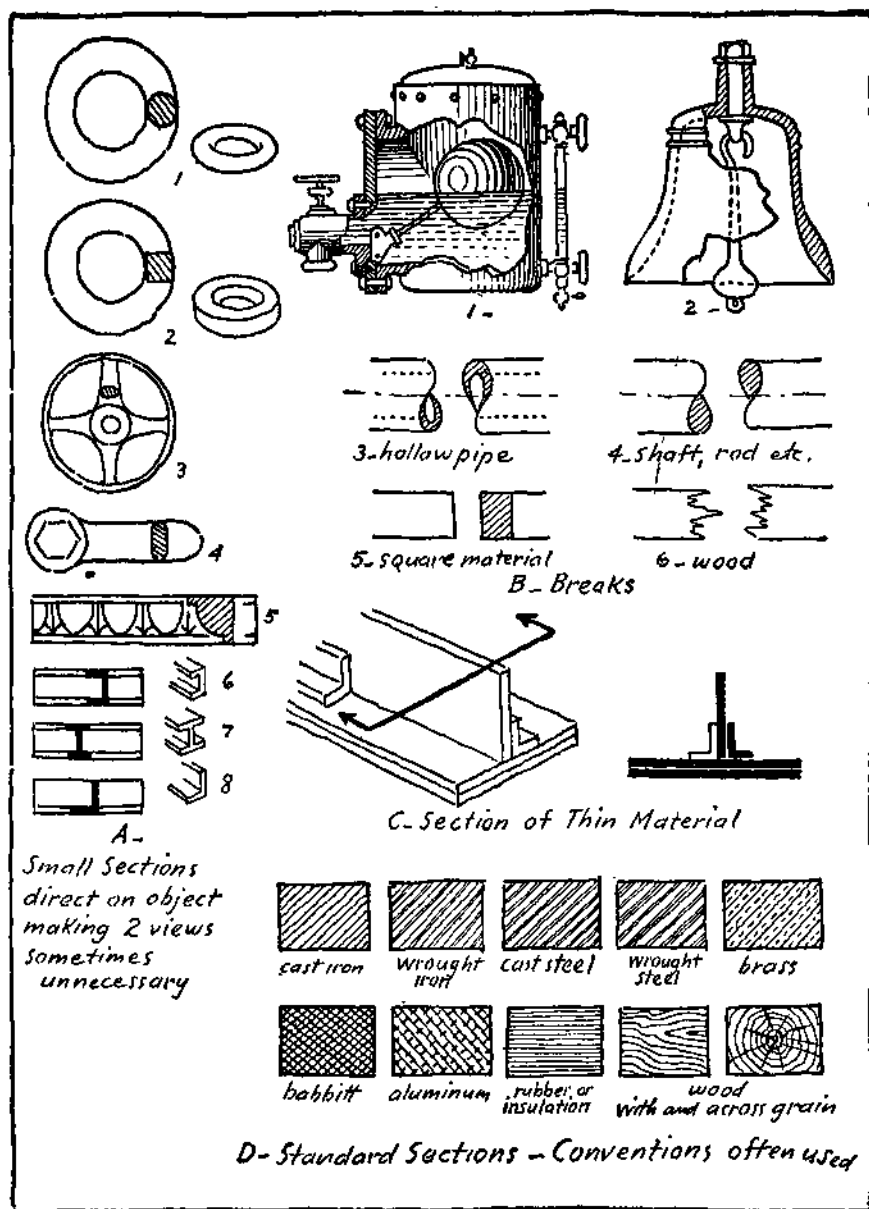

PLATE 37. Special Sections.

this variation in the cutting plane as such views are standard practice.

Special Sections. — An extra view can often be avoided by placing a section on a full view as indicated at A on Plate 37. Architectural details such as mouldings and panels, furniture parts, etc., are often shown to advantage in this way.

Sometimes a partial section is shown by "breaking away" a part of an exterior view as at B, 1 and 2, on Plate 37. A long piece of uniform section may be "broken" as B, 3, 4, 5, and 6, Plate 37. The shape of the cross section is indicated by the break.

Long thin sections such as occur in structural work are difficult to cross hatch and are generally shown solid black. When plates, angle bars, etc., are in contact they are separated by a "white" line as at C, Plate 37.

Sectioned surfaces, in general, are best represented on sketches by the symbol for cast iron shown at D, on Plate 37. A note to tell the name of the material makes the description definite. On drawings other symbols are sometimes used such as those of the American Society of Mechanical Engineers which are given at D, Plate 37.

Problems. — A thorough understanding of the subject of sectional views is necessary for the making and using of industrial sketches and drawings. Problems should be selected from each group. The view to be sectioned should *not be copied* and changed but should be worked out at once as a section.

Use layout No. 1 or No. 2 of Plate 4 depending upon the size and arrangement of views. The section lines should be lighter and finer than the main lines of the views.

Section planes which are not continuous as those at H and J of Plate 36, are represented either straight across or as plain center lines on practical sketches. They are shown as on Plate 36 and on some of the problems for purposes of explanation and must not be copied when the problems are solved.

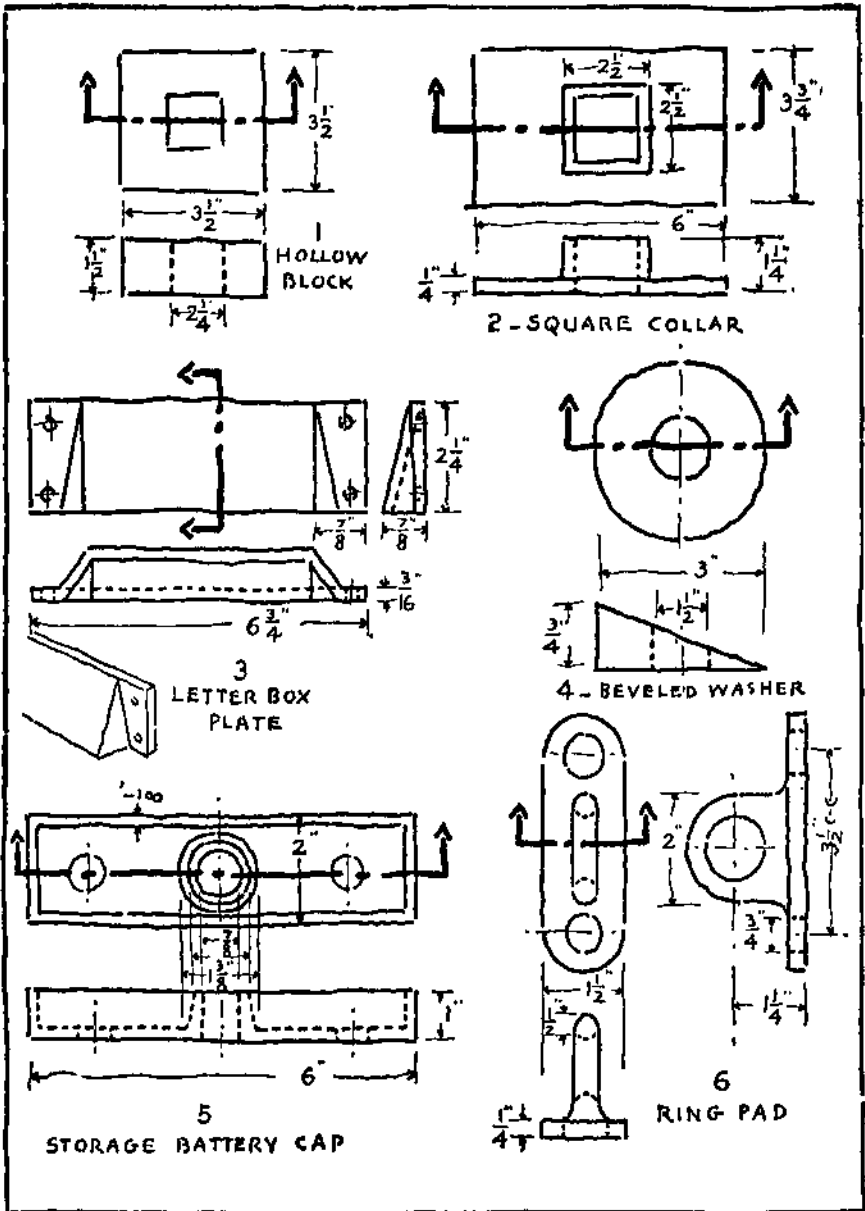

PLATE 38. Problems 1 to 6.

PROBLEMS 1 to 6, PLATE 38. — Sketch the necessary views showing the sectional views as called for by the cutting planes indicated.

PROBLEMS 7 to 10, PLATE 39. — Sketch the necessary views and sections as indicated or some views as half sections where desirable.

PROBLEMS 11 and 12, PLATE 40. — Sketch the necessary views and sections.

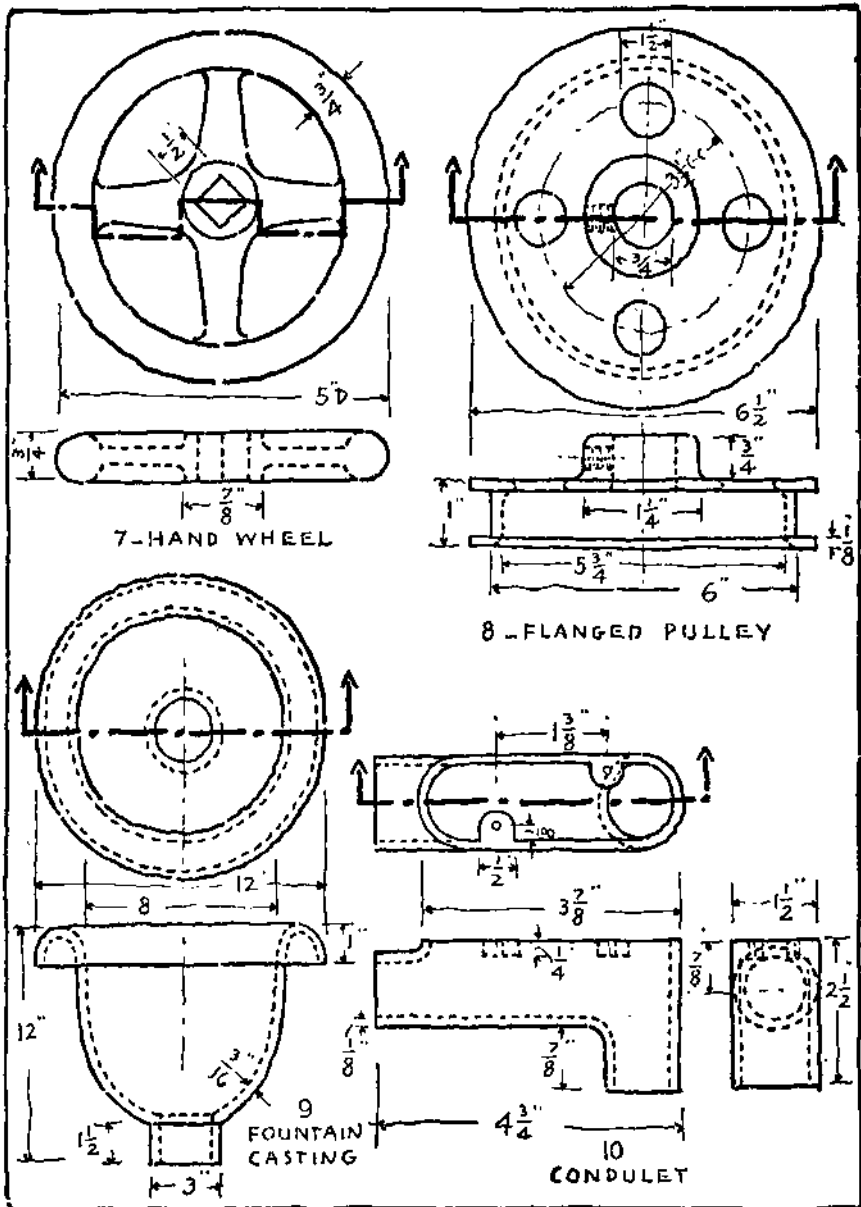

PLATE 39. Problems 7 to 10.

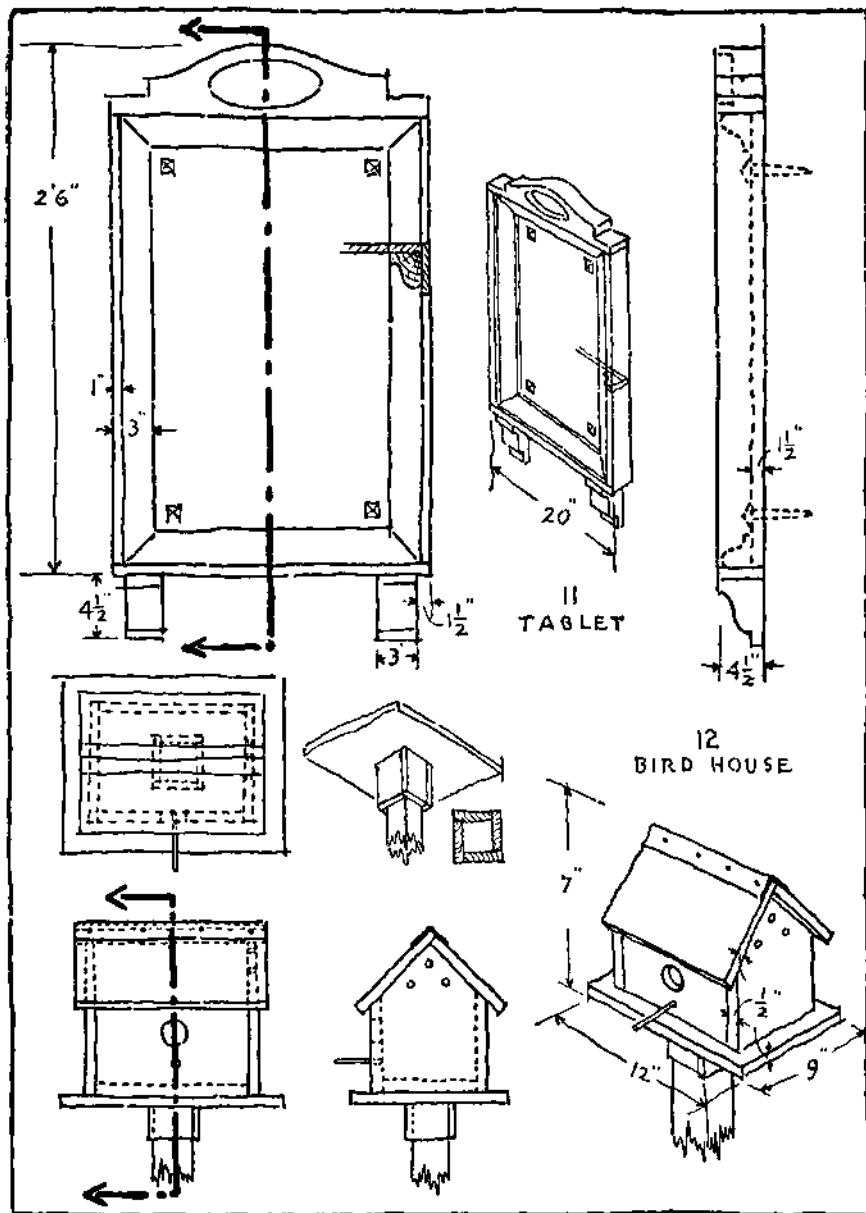

PLATE 40. Problems 11 and 12.

MEMORANDA

7

CONVENTIONAL PRACTICE

MEMORANDA

7

CONVENTIONAL PRACTICE

Conventional Methods. — Mechanical drawings and sketches could be made to conform strictly with the principles of geometry and projection. The use of the graphic language in the industries has shown that certain variations, symbols and conventional methods are often desirable. They save time, lessen work and often give a better description than purely theoretical methods. Precedent and long usage have sanctioned the use of a number of these conventional representations. Some are used in all branches of engineering drawing and some are peculiar to the different industries.

The fundamental principles, however, are the same for all branches of industry. The lines used for various purposes on drawings are practically standard, and their purpose and character must be understood. Each line has its own use and meaning. The lines used in this book are shown on Plate 41.

Full Lines. — These lines are used to represent visible edges and outlines. They are drawn as a continuous line and heavier than any of the other lines. This makes the shape "stand out" and results in a more easily read drawing.

Hidden Lines. — Features which are hidden from view are represented by a series of short dashes — called hidden lines. What is hidden or invisible in one view may or may not be hidden in another view.

Center Lines. — Center lines are used to indicate the axes of cylindrical and symmetrical objects and various other "location" purposes. On drawings they are generally made very fine "dot and dash" lines as shown on Plate 41. On freehand pencil sketches they are frequently made very light continuous lines.

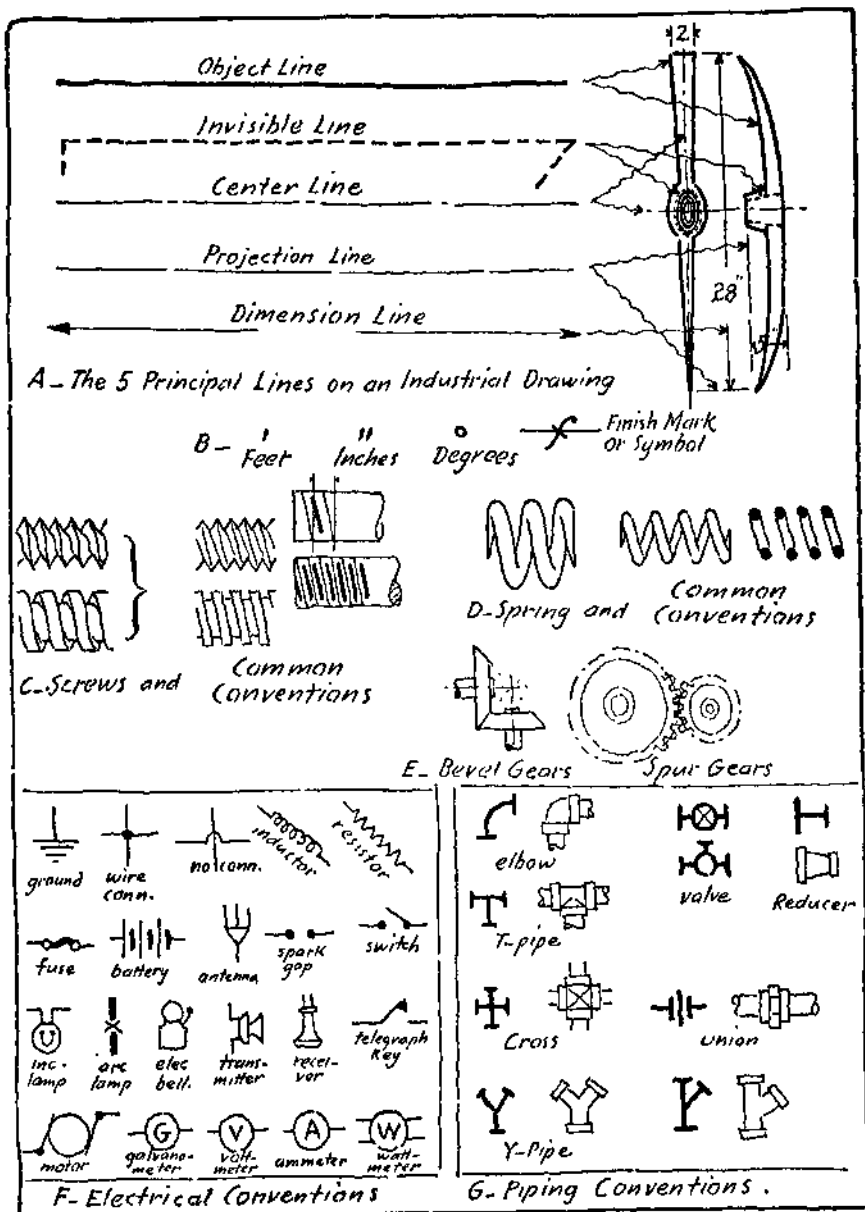

PLATE 41. Lines and Conventions.

Cutting Plane Lines. —Heavy dash and double dot lines used to indicate the edge of imaginary cutting planes for sectional views.

Extension Lines.— Thin continuous lines used to extend the lines of the views in order to locate dimension lines.

Dimension Lines. — These are lines which show the extent of the dimensions put on a drawing to tell the sizes of the parts. They are thin full lines with arrowheads at each end. A space is generally left for the dimension as shown. Dimension lines must always extend the full length of the dimension which they indicate.

Dimensioning. — The subject of dimensioning is very important and should be made a special study. A complete treatment will be found in the chapters on DIMENSIONING in Svensen's " Machine Drawing " and " Drafting for Engineers," both published by D. Van Nostrand Company, Inc., New York.

Some general rules for dimensioning follow:

General practice is to place horizontal dimensions to read from the bottom, and vertical dimensions from the right side. Aircraft practice is to place all dimensions to read from the bottom of the sheet and this is finding considerable acceptance in other industries.

Dimensions placed between views or outside of views are easier to read, especially if the views have a large amount of detail.

Do not repeat a dimension unless there is a real and important reason for so doing.

Where a series of dimensions occur as on a shaft or in other cases where a check is desirable, the over-all dimension should be given.

Holes, rounds, etc., are located by their centers. Such dimensions are often marked C-C (center to center).

When a dimension line is very short, arrowheads should be reversed and the figure placed between, or outside, the extension lines.

Symbols for feet, inches, degrees, and to indicate a finished or machined surface, are shown at B on Plate 41. Present practice where all dimensions are in inches is tending more and more to omitting the symbol for inches.

The purpose of dimensions, which is to specify sizes, should be kept in mind and should be made as complete and accurate as the description of shape.

Cut Stone Brick Sand Rock

Terra Cotta Concrete Earth Water

Wood Section End

Single Door Double Acting Door

Sliding Door Window

Stairs

A- Architectural Conventions

	Ceiling		Outlets	
electric		gas		combination 4, 16 C P. inc lamps 2, gas burners
	Bracket		Outlets	
electric		gas		combination
	Drop cord Outlet		Floor Outlet	
				Special Outlet

B- Riveting Conventions. (Osborn)

	Shop	Field	far side	near side	both sides
2 Full Heads					
C'sunk farside, chipped					
" nearside, "					
" bothsides, "					

PLATE 42. Architectural and Structural Conventions.

, Scale Drawings—Freehand sketches are made in estimated proportion without the use of a scale. Buildings, ships, bridges, plans, maps, and the like must be represented many times smaller than their size. In order to have proportions accurate an object may be drawn $\frac{1}{2}$, $\frac{1}{4}$, $\frac{1}{8}$, or $\frac{1}{16}$ of the actual size or scale. Half scale means that each half inch on the drawing represents a full inch of the object and similarly for other fractions. Some draftsmen use special scales which are made for this purpose. When practicable, however, a full size drawing is to be preferred. Very small pieces, as the works of a watch, delicate machinery, etc., are drawn to an enlarged scale. Whether enlarged or reduced, the scale must always be given on a drawing.

When sketching freehand the proportions should be judged by eye as closely as possible. The correct proportions of the three main dimensions, length, breadth, and thickness should be estimated first. The other distances will follow from them. The addition of the dimensions will specify the actual sizes.

Conventional Representations. — A number of conventional representations used on different kinds of drawings are shown on Plates 41 to 43. These are not intended to be complete but will suggest some of the types of symbols used for various purposes.

It will be noted that most of the symbols have a certain resemblance to the features which they represent. This scheme makes the reading of such drawings easier than if arbitrary symbols were used.

Rome conventions, notably electrical and piping, are largely diagrammatic, and a few lines are adequate to serve the necessary purpose. While practice is not uniform most symbols can be easily read. When necessary an explanatory diagram is shown on the drawings, as in the case of maps of the United States Geological Survey.

Working Sketches. — The subjects treated in this and the preceding chapters are a preparation for making use of the graphic language in the form of idea or invention sketches, executive

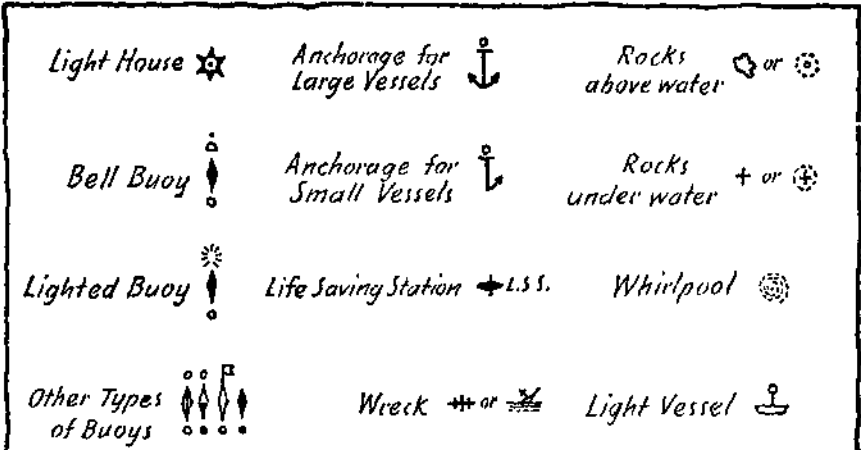

A - U.S. Hydrographic Conventions.

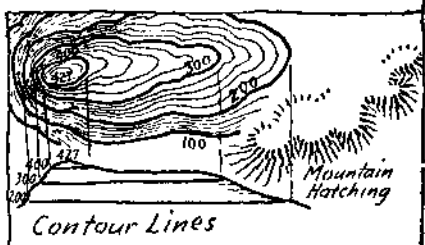
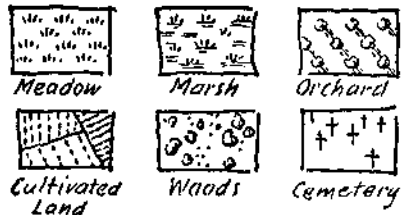
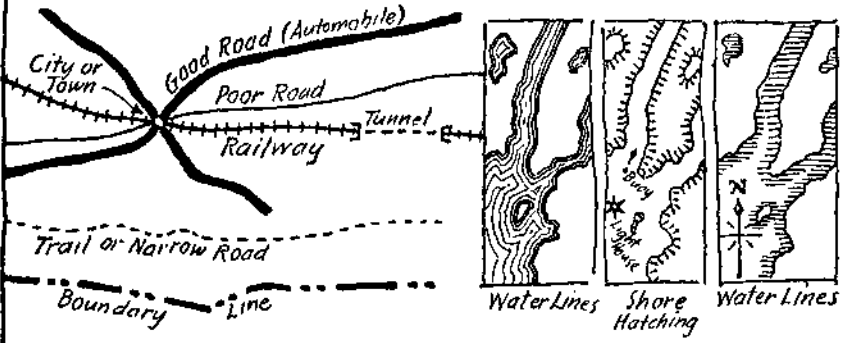

B - Topographical Conventions

PLATE 43. Hydrographic and Topographical Conventions.

sketches, explanatory sketches, interpretation sketches, preliminary sketches, diagram sketches, working sketches, and other freehand graphic descriptions.

A shop sketch is probably the most definite for practice purposes as well as being a very useful type of sketch. The steps in the making of such a sketch are as follows:

Consider the object or construction to be described.

Choose the necessary views.

Outline or block-in the views.

Complete the details.

Sketch all the extension and dimension lines.

Fill in the dimensions. If sketch is made from machine or part, take measurements and insert each measurement in its place as soon as taken.

Add any notes which may be necessary to give information as to material, number required, kind of finish, etc.

Each of the steps above should be taken and completed in the order specified.

Problems. — The problems which follow will give additional practice in the work of the preceding chapters. They should, however, be carried to completion with dimensions and proper views, using sections or conventional treatment where necessary so that the result will be a practical and complete sketch for the conditions indicated.

PROBLEMS 1 to 4, PLATE 44.— Make complete working sketches for each piece.

PROBLEMS 5 to 8, PLATE 45. — Make complete working sketches for each piece.

PROBLEMS 9 to 12, PLATE 46. — Make complete working sketches for each piece.

PROBLEMS 13 to 16, PLATE 47. — Make complete working sketches for each piece.

PROBLEMS 17 to 20, PLATE 48. — Make complete working sketches for each piece.

PROBLEMS 21 to 24, PLATE 49. — Make complete working sketches for each piece.

PROBLEMS 25 to 28, PLATE 50. — Make complete working sketches for each piece.

PROBLEMS 29 to 31, PLATE 51. — Make working sketches of a part of each of the two hand rails. Make a working sketch of a CHAIR LEG.

PROBLEMS 32 to 35, PLATE 52. — Make complete working sketches using sections as indicated.

PROBLEM 36, PLATE 53. — Make complete working sketch of the DECK PLATE, one view in section.

PROBLEM 37, PLATE 53. — Make a sectional view of the LONGITUDINAL BULKHEAD using the "blacked-in" section as shown for thin material on Plate 30.

PROBLEMS 38 and 39, PLATE 54. — Make sectional assembly views of the UNION and of the SPARK PLUG.

PROBLEMS 40 to 42, PLATE 55. — Make complete working sketches of each piece.

PROBLEMS 43 and 44, PLATE 56. — Make general assembly sketches as indicated in the small sketches.

PROBLEMS 45 to 50, PLATES 57 to 59. — Make general assembly sketches as indicated in the small sketches.

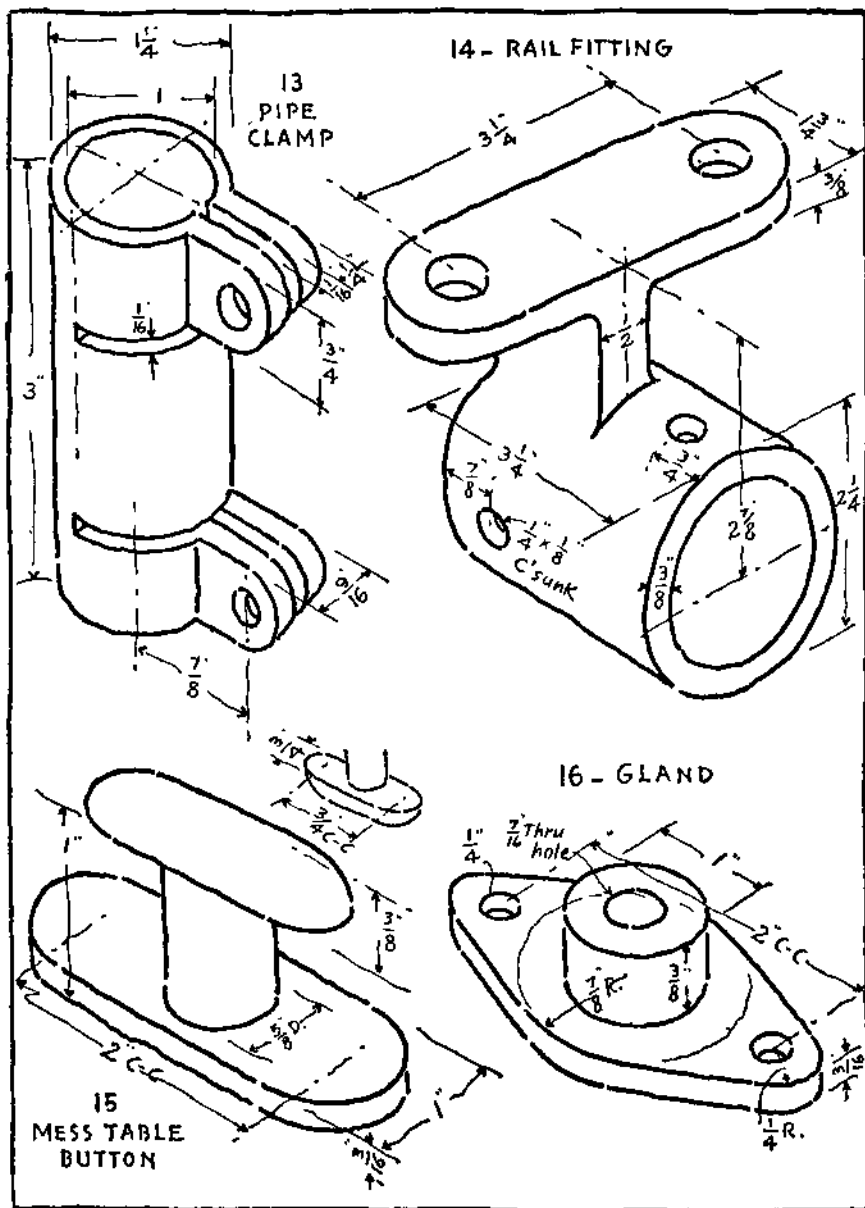

PLATE 47. Problems 13 to 16.

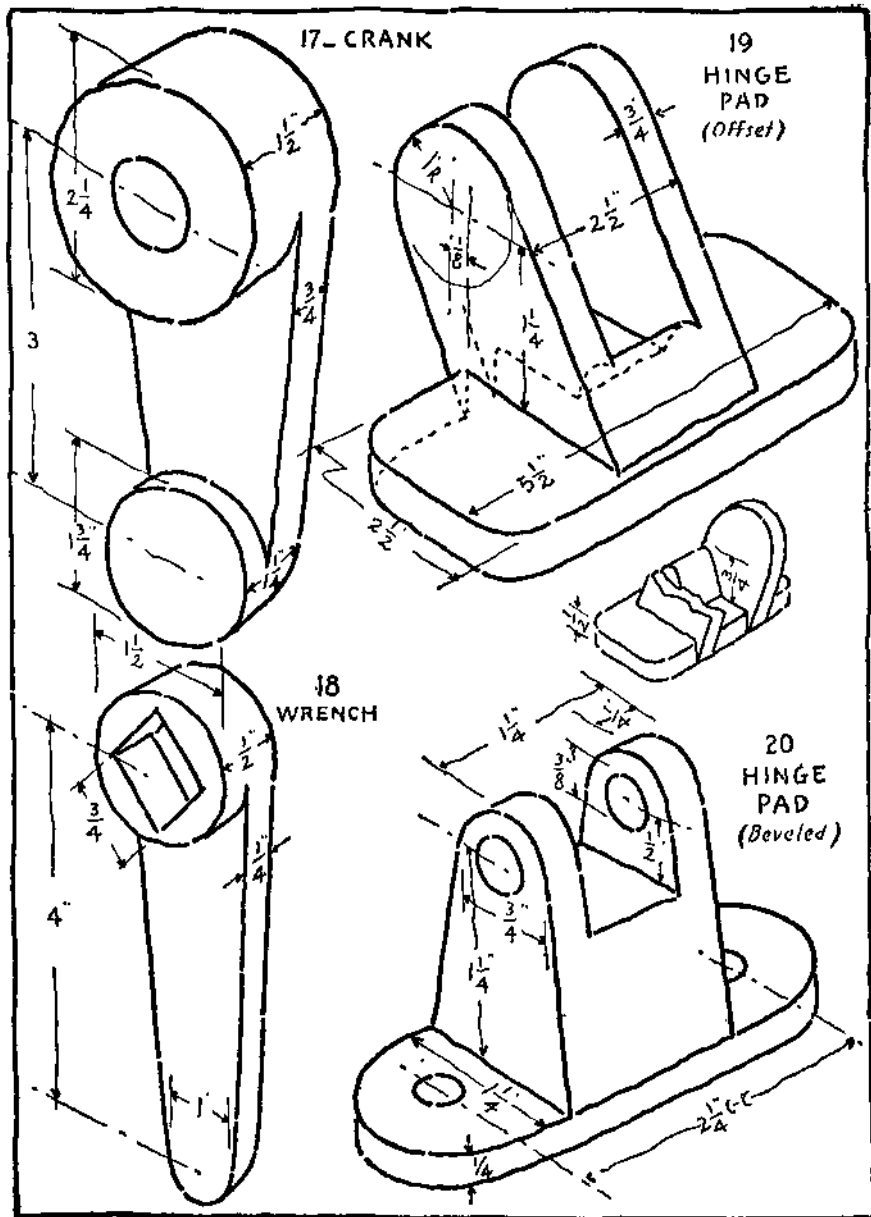

PLATE 48. Problems 17 to 20.

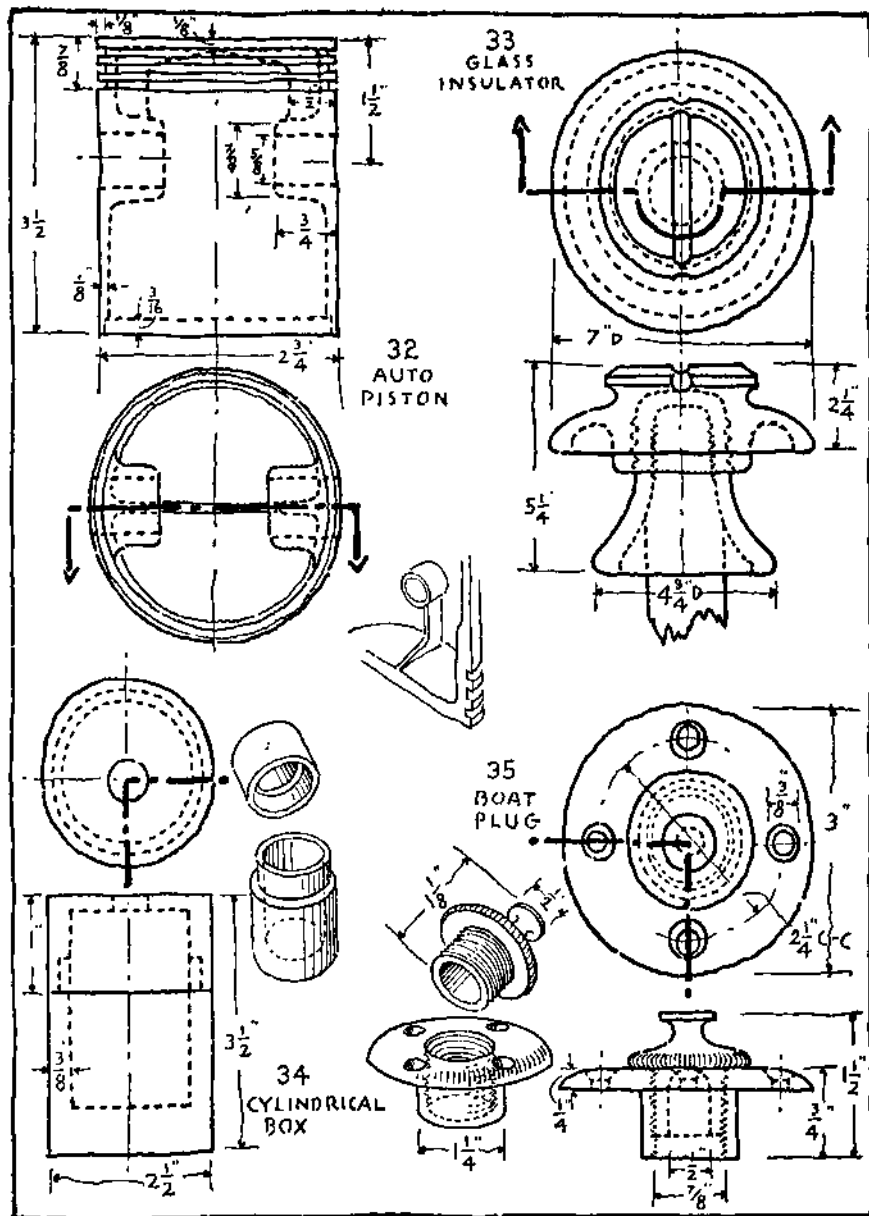

PLATE 52. Problems 32 to 35

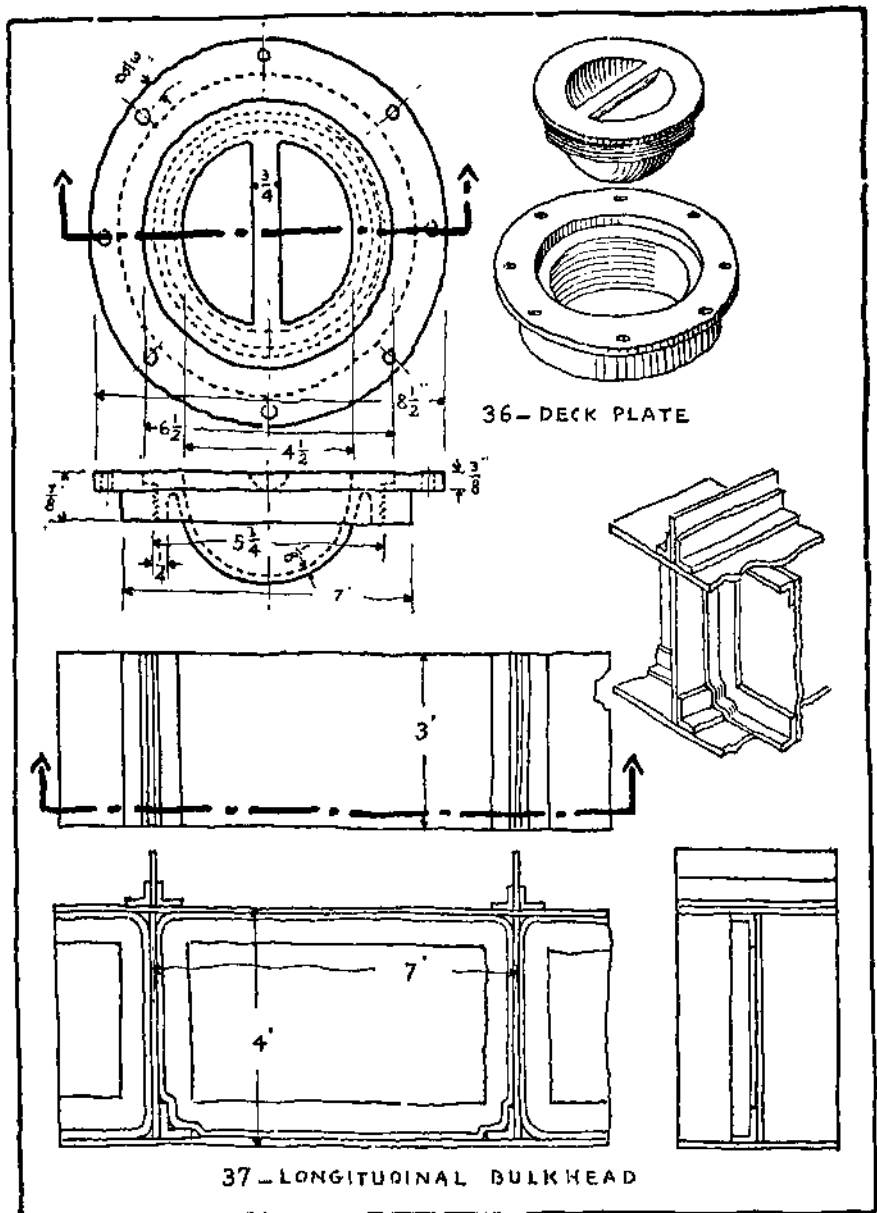

PLATE 53. Problems 36 and 37.

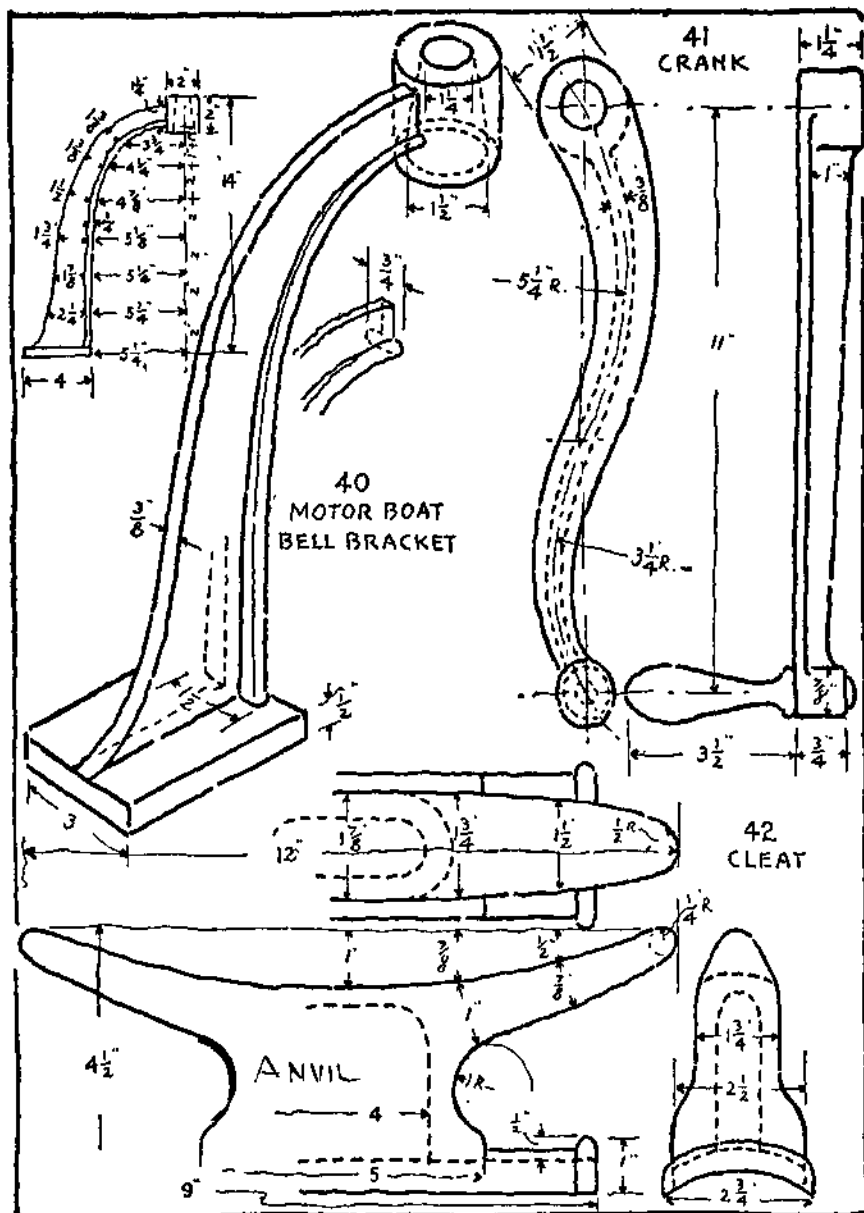

PLATE 55. Problems 40 to 42.

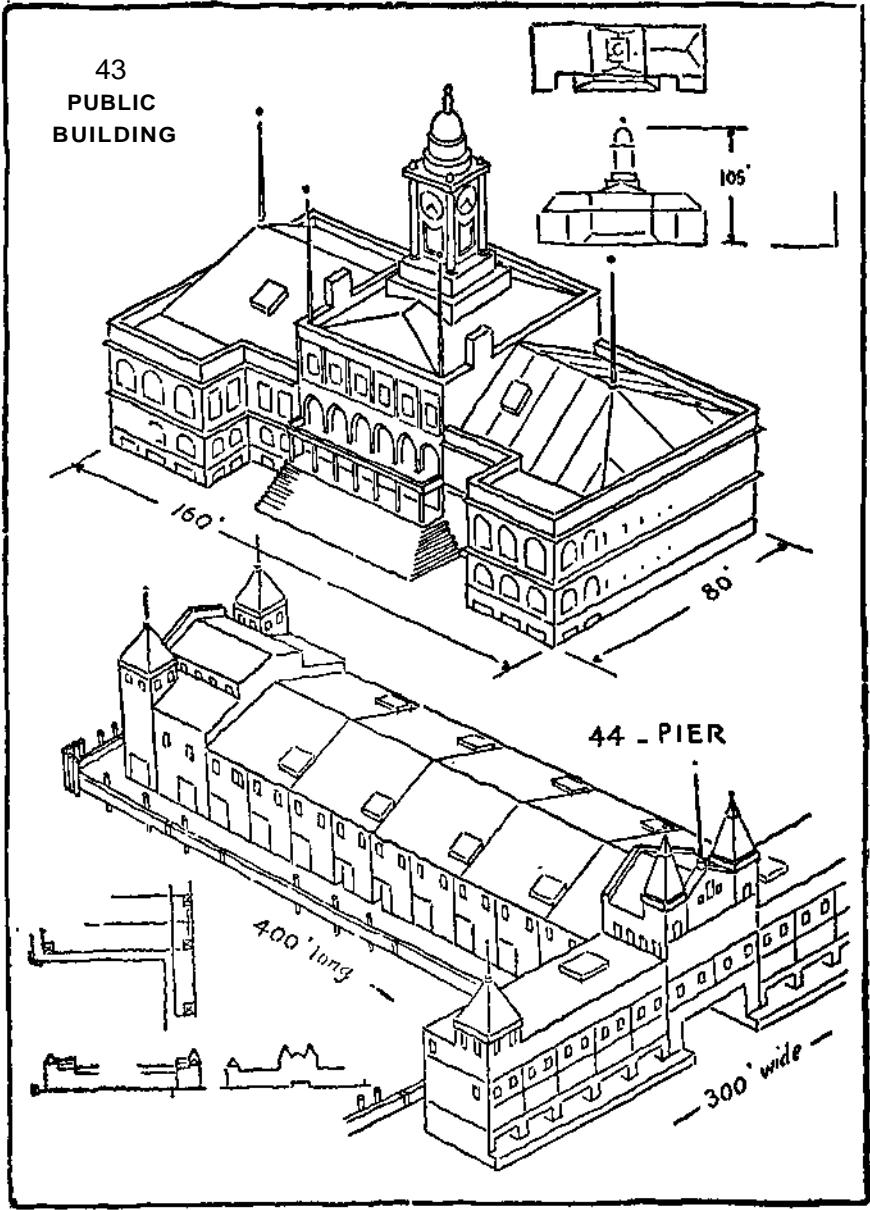

PLATE 56. Problems 43 and 44.

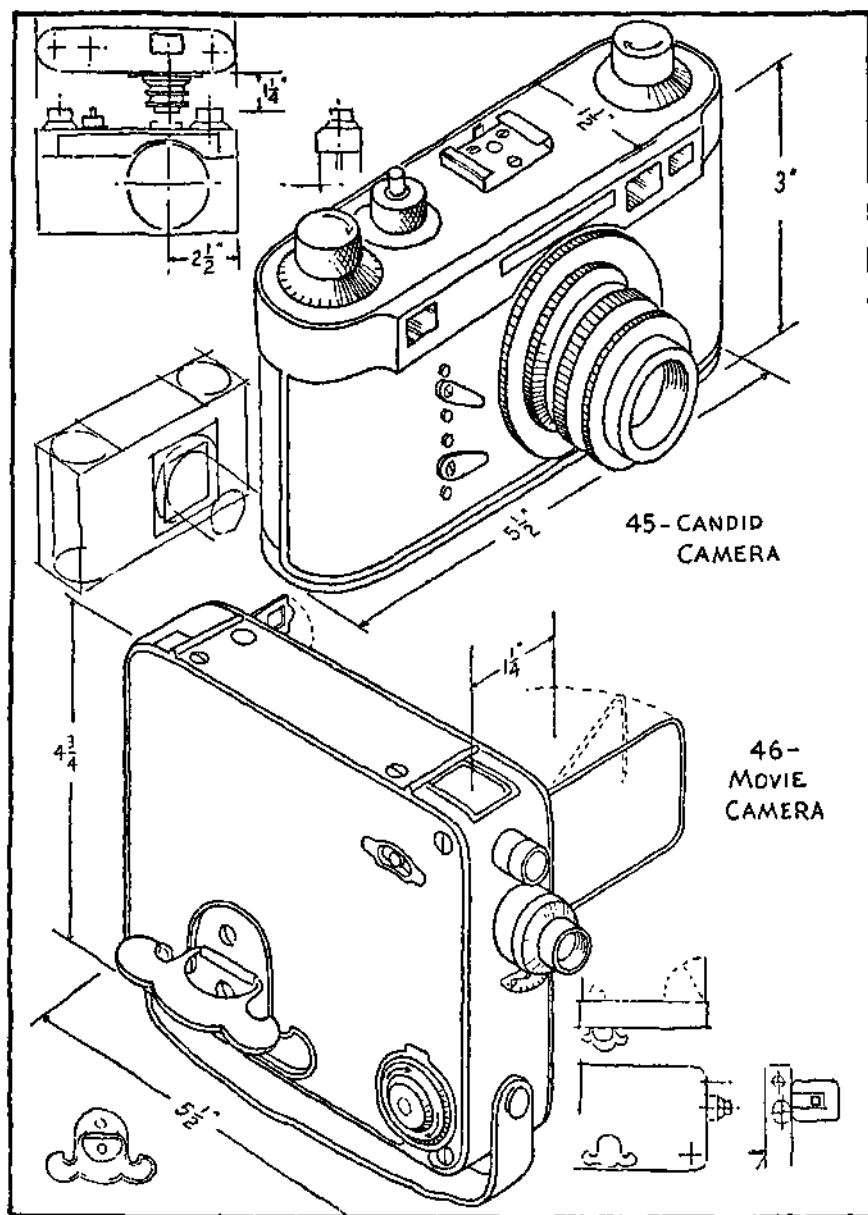

PLATE 57. Problems 45 and 46.

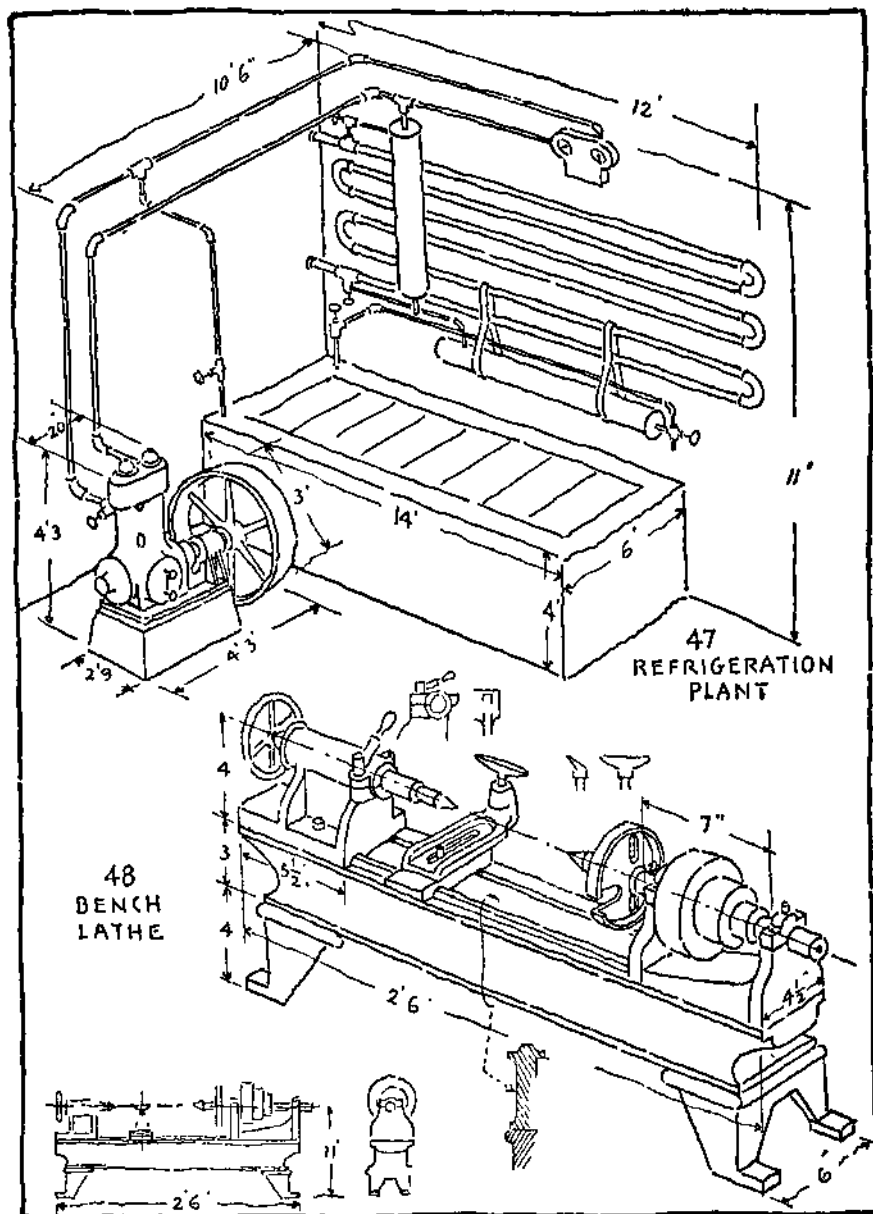

PLATE 58. Problems 47 and 48.

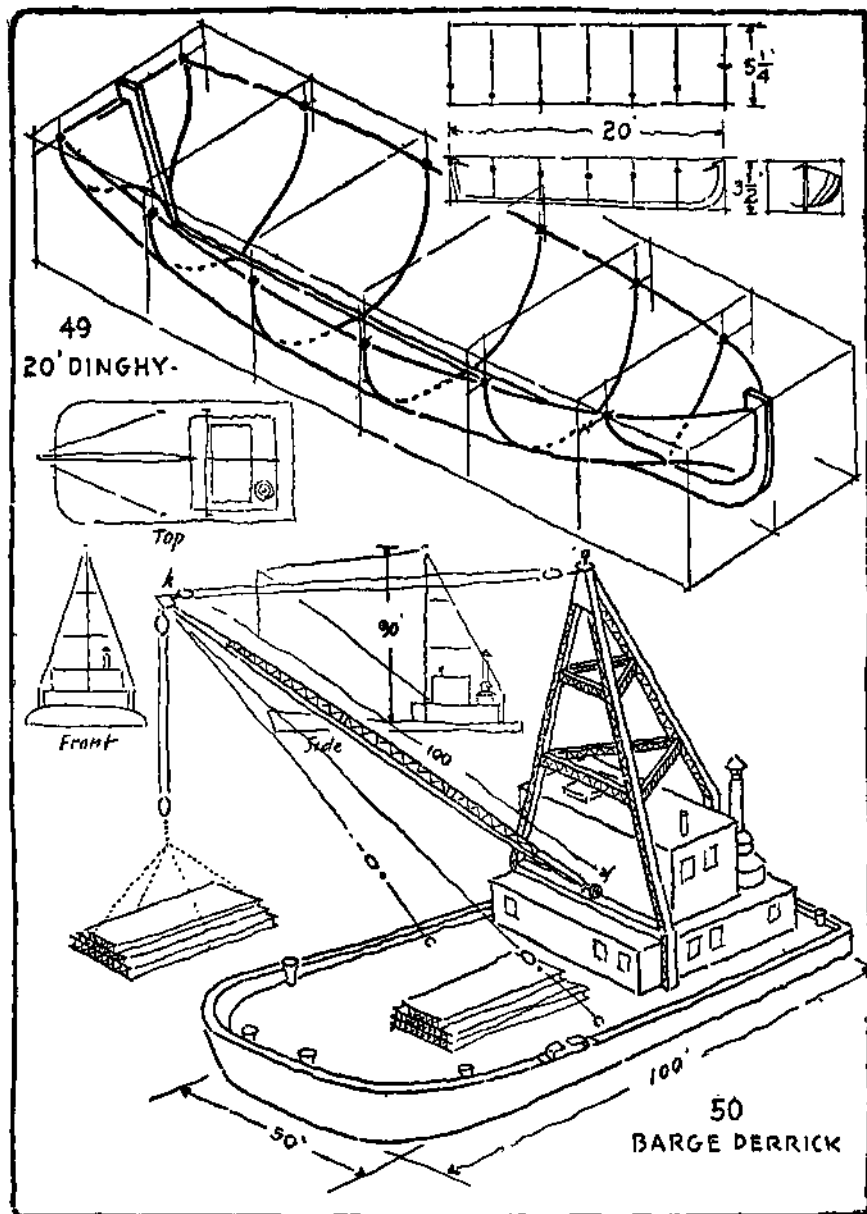

PLATE 59. Problems 49 and 50.

8

ISOMETRIC SKETCHING

MEMORANDA

8

ISOMETRIC SKETCHING

Kinds of Pictorial Representation. — The most satisfactory method of representation for mechanical purposes is by orthographic views. These are made and used by draftsmen and engineers in all countries. A knowledge of the principles of projection and of conventional practice is, of course, necessary for a thorough understanding and intelligent use of such drawings.

When anyone who is not familiar with these principles must be informed, other methods of representation are desirable. In the examination of a blueprint or its explanation to a customer or investor, the business man, financier, and promoter often finds himself at a disadvantage because of his inability to visualize quickly from the orthographic views. There are times when the shape of a piece of machinery is such that even technical men find difficulty in forming a mind's eye picture. This may apply to the whole drawing but generally it is only a part of the construction.

As an aid in overcoming the difficulties enumerated, various methods of pictorial representation are employed such as perspective, isometric, oblique, and cabinet drawing. All of these give a picture more or less like a photograph, showing the top, front, and side in one view instead of three as in orthographic projection.

Isometric drawings while less pleasing than perspective are based upon simple principles which can be easily understood. They are satisfactory for sketching mechanical constructions as can be seen by an examination of the illustrations in this book.

Uses of Pictorial Representation—Pictorial drawings have a very limited field of use compared with projection drawings. However, they have a distinct use in the following cases:

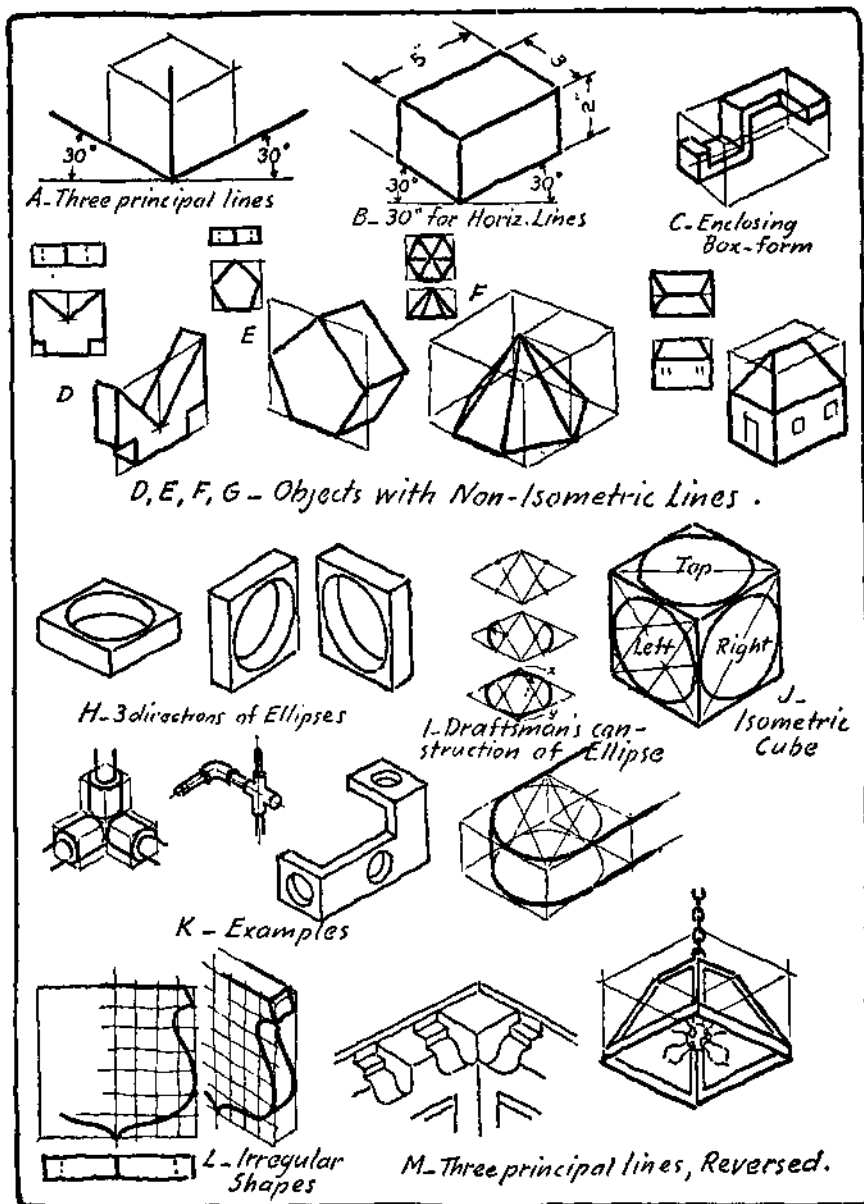

PLATE 60. Isometric Views.

For the explanation of orthographic views to non-technical men or others who are uninformed.

For Patent Office drawings of new inventions, especially if the device or design is complex.

For drawings used to promote the sale of a new device, machine, etc.

For plumbing, piping and refrigerating system drawings. Isometric drawings show the positions of the various features definitely and require very little time for reading.

For supplementing the working drawings in making clear details of interior building construction, woodwork, and joinery.

For illustrating trade catalogs, advertising matter and other literature which must be easily read or for the use of non-technical men.

Principles of Isometric Drawing. — For sketching purposes a few simple principles will give the information necessary for making isometric views. The object to be represented is placed in the position of a cube which has three faces showing to an equal extent as at A of Plate 60. The three principal lines or axes form the basis of each drawing.

Two of these lines form angles of 30° with the horizontal and the third is vertical.

All measurements are made on the three principal lines, or lines parallel to them as at B, Plate 60. For sketches estimate distances on these lines. It is often convenient to consider the objects as enclosed in a box as at C.

Invisible edges are very seldom shown on isometric views as they tend to complicate the representation.

Non-isometric Lines. — Lines which are not parallel to the three principal lines cannot be measured and are called non-isometric lines. Such lines are drawn by first locating their end points and then joining them as shown at D, E, F, and G, of Plate 60 and B of Plate 61. This is often conveniently done by enclosing the object in an imaginary box as indicated. Sometimes the ortho-

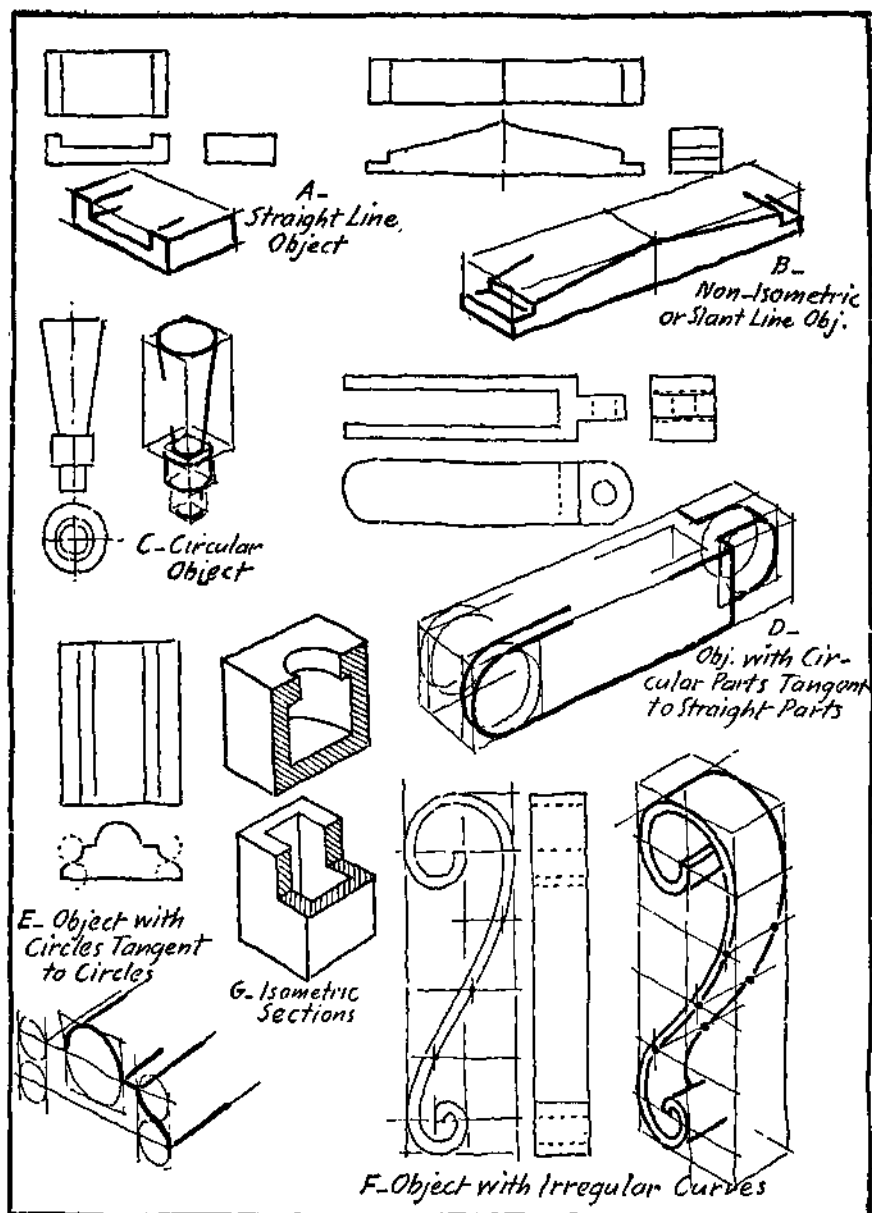

PLATE 61 "Blocking-in" for Isometric Views.

graphic views are made first as an aid in locating points on the isometric planes.

Circles and Curves. — Since the isometric planes are not parallel to the picture plane, it follows that circles will appear as ellipses. A circular hole will appear as at H, Plate 60. When drawing with instruments, an approximate ellipse may be constructed by circular arcs, as at I, Plate 60. From the obtuse angles draw lines to the centers of the opposite sides. Where these intersect will give centers for the small arcs. Complete the figure with arcs having centers at x and y . A similar construction can be used to advantage when sketching.

The appearance of the ellipses which represent circles on the three isometric planes can be understood by reference to the isometric cube shown at J, Plate 60. This is an important figure which should be remembered. Note that the long diameter of the top ellipse is horizontal. The left and right ellipses have their long diameters joining the acute angles of the enclosing face of the cube.

Parts of circles are constructed or sketched as parts of ellipses as indicated in the illustrations.

The isometric view of an irregular curve can be constructed by first making an orthographic view with offsets or squares. The enclosing figure can then be drawn in isometric with the same offsets or squares, which will locate points on the irregular curve, as at L, Plate 60, and F, Plate 61.

Isometric Sections. — Isometric views showing the interior details can be constructed in the same manner as for exterior views. In general the cutting planes are taken parallel to the faces of the isometric cube, Plate 61 at G.

Reversed Axes. — The axes may be reversed if necessary to show desired features as for an airplane, roof edge, coping or where important details are on an under surface. This is illustrated at M, Plate 60, which shows views from below.

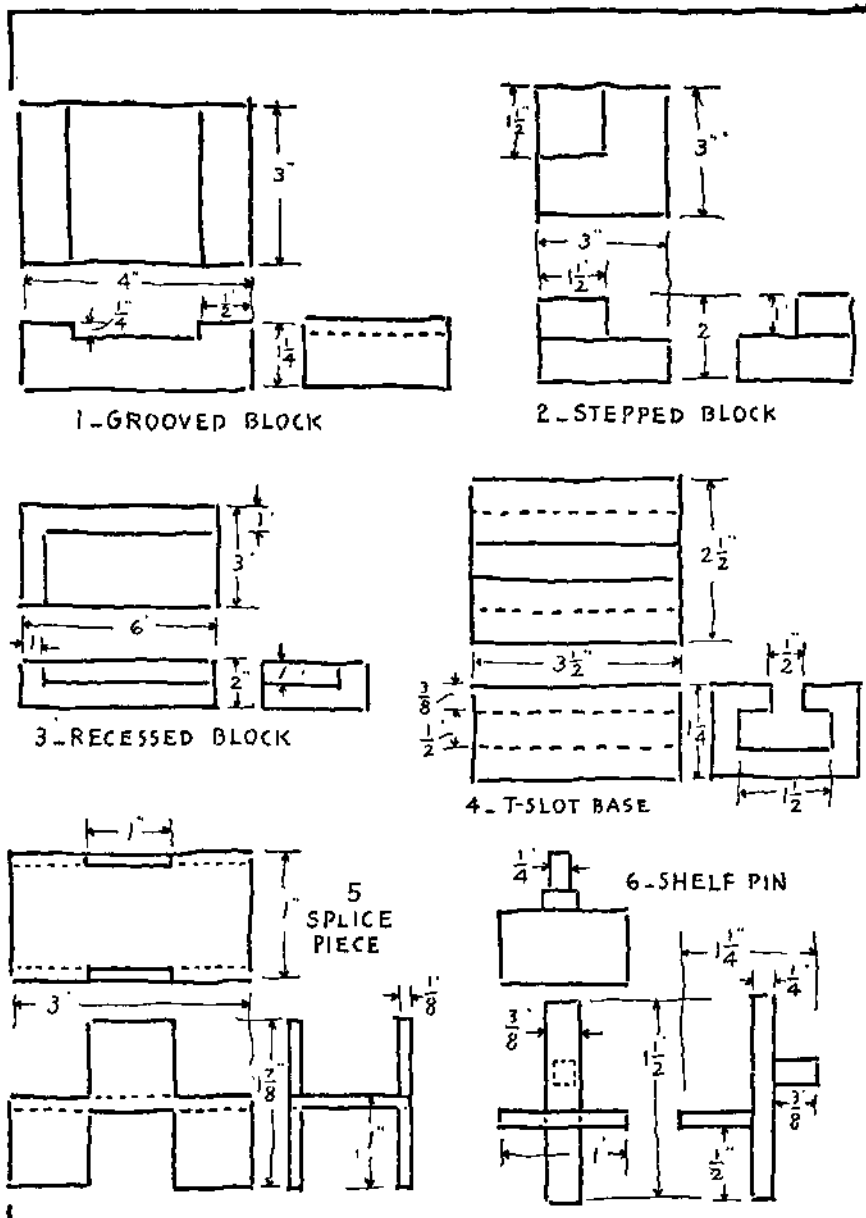

PLATE 62 Problems 1 to 6.

Isometric Sketching Problems. — The exercises which follow are to be sketched as isometric views. First locate the three isometric axes or principal lines. Then block in an enclosing figure and proceed to fill in the details. System and order must be used and will make isometric sketching surprisingly easy. The method of procedure is illustrated on Plate 61.

Use layout No. 1 or No. 2 of Plate 4. Make construction lines very light so as to avoid too much erasing. It is not necessary that all the problems be worked but a selection should be made from each plate. Other problems may be selected from Chapter 5 if desired.

PROBLEMS 1 to 6, PLATE 62. — Sketch isometric views of each of the objects. Do not represent any invisible lines. Estimate distances along isometric lines.

PROBLEMS 7 to 12, PLATE 63. — Sketch isometric views of each of the objects shown. Construct imaginary boxes to contain the object and locate the ends of the non-isometric lines.

PRACTICE EXERCISES, PLATE 64. — This plate is for practice in sketching ellipses and should be fully understood before proceeding with the problems which follow. Always draw the enclosing straight line figure. The first row shows the isometric cube and the three faces separately. The second row shows four regular positions for half ellipses in a top plane. Representations in left and right faces are given in the third and fourth rows. Care must be taken when sketching half ellipses that they do not become half circles. Note the sharp bend as exaggerated in the small figure of each exercise. The last row gives applications of the practice exercises.

PROBLEMS 13 to 18, PLATE 65. — Sketch isometric views of each object. Construct imaginary boxes to enclose the objects and block-in for each circle. Do not make the sketches too small.

PROBLEMS 19 to 24, PLATE 66. — Sketch isometric views.

PROBLEMS 25 to 28, PLATE 67. — Sketch isometric views.

PROBLEMS 29 to 32, PLATE 68. — Sketch isometric views. Note the irregular curves which should be sketched as orthographic views and put into isometric by using squares or offsets as indicated at F on Plate 61.

PROBLEMS 33 to 37, PLATES 69 to 71. — Studies for practice in isometric representations of assembled constructions and machines.

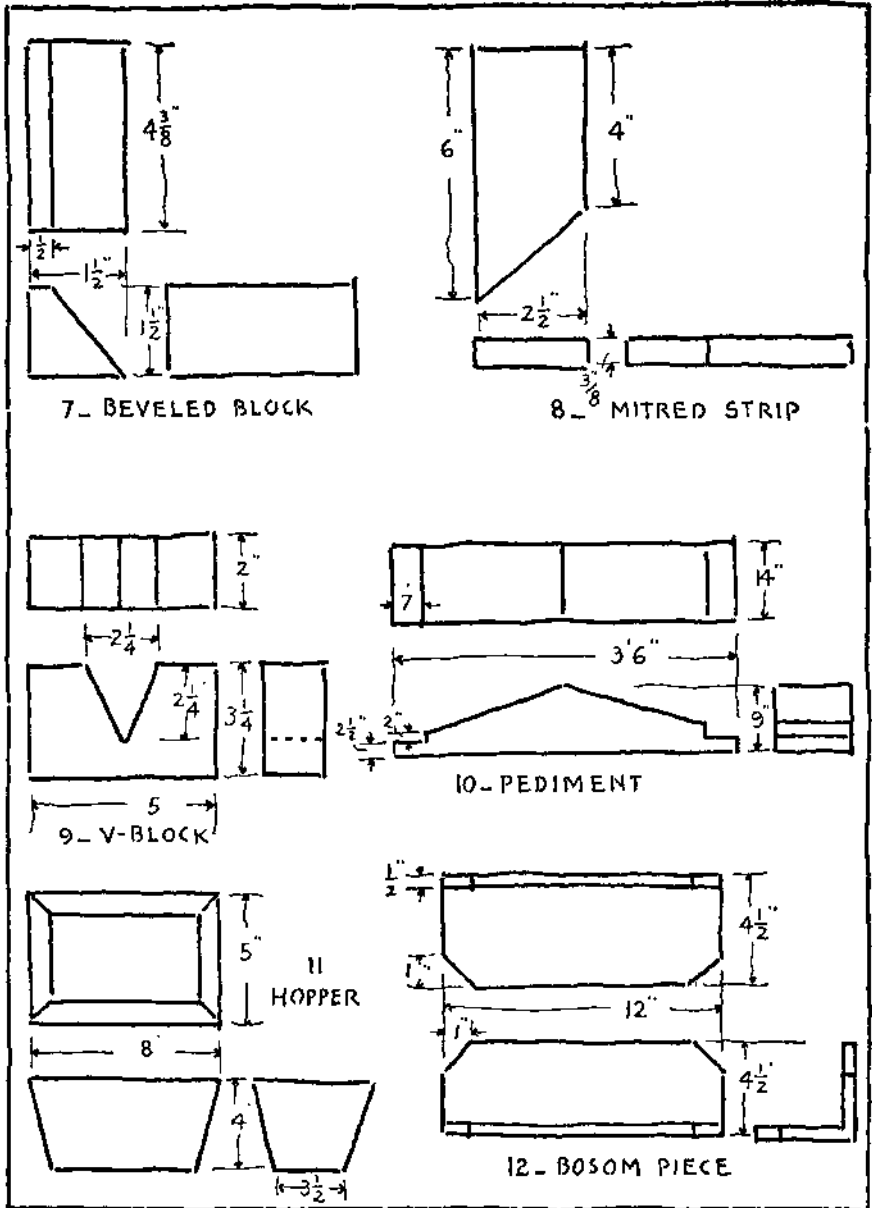

PLATE 63. Problems 7 to 12.

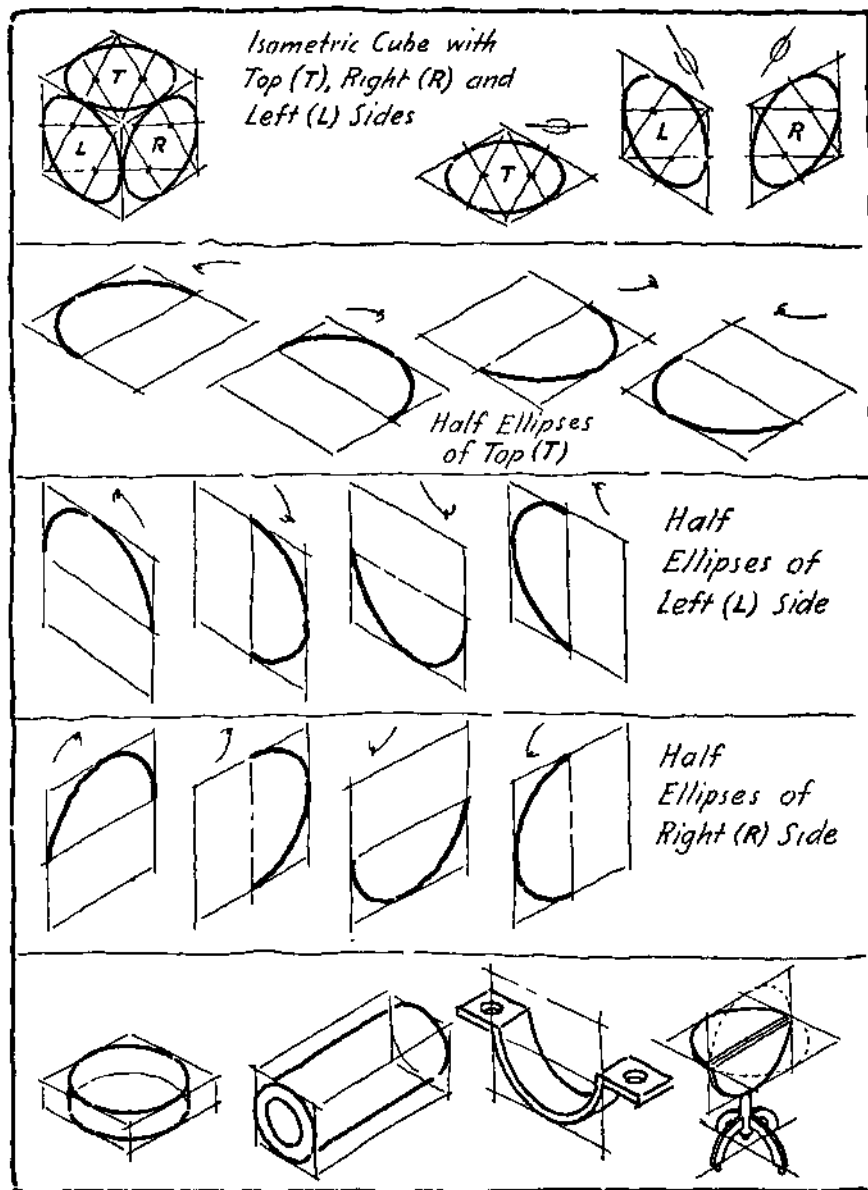

PLATE 61 Ellipse Construction Practice Exercises.

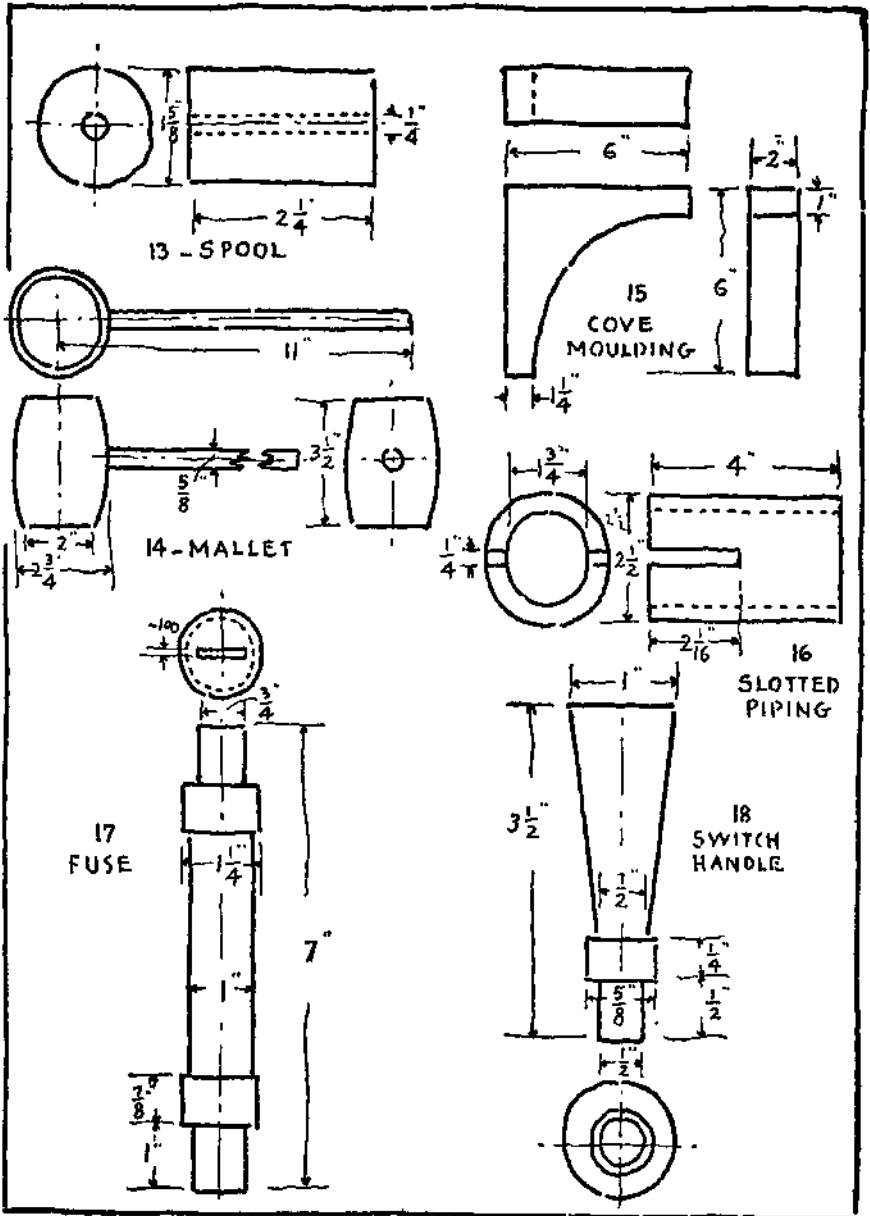

PLATE 65. Problems 13 to 18,

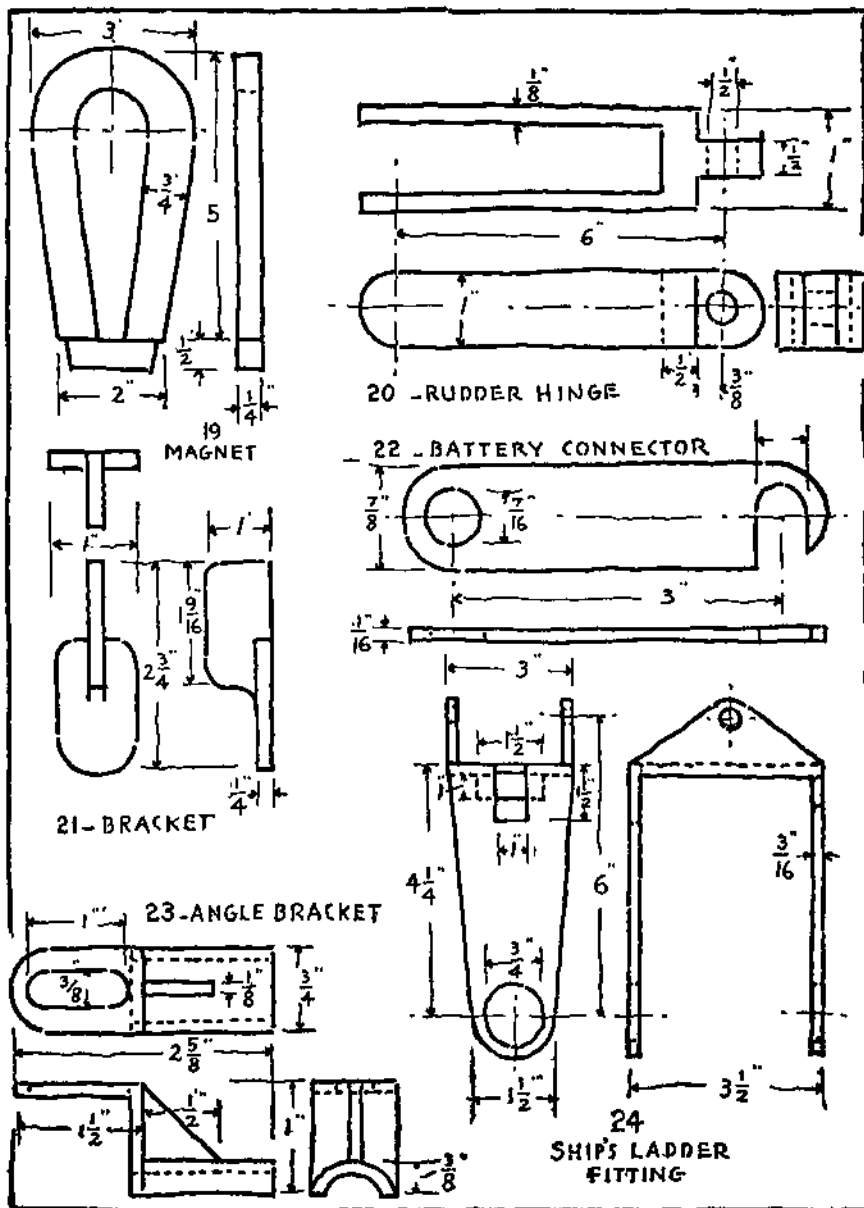
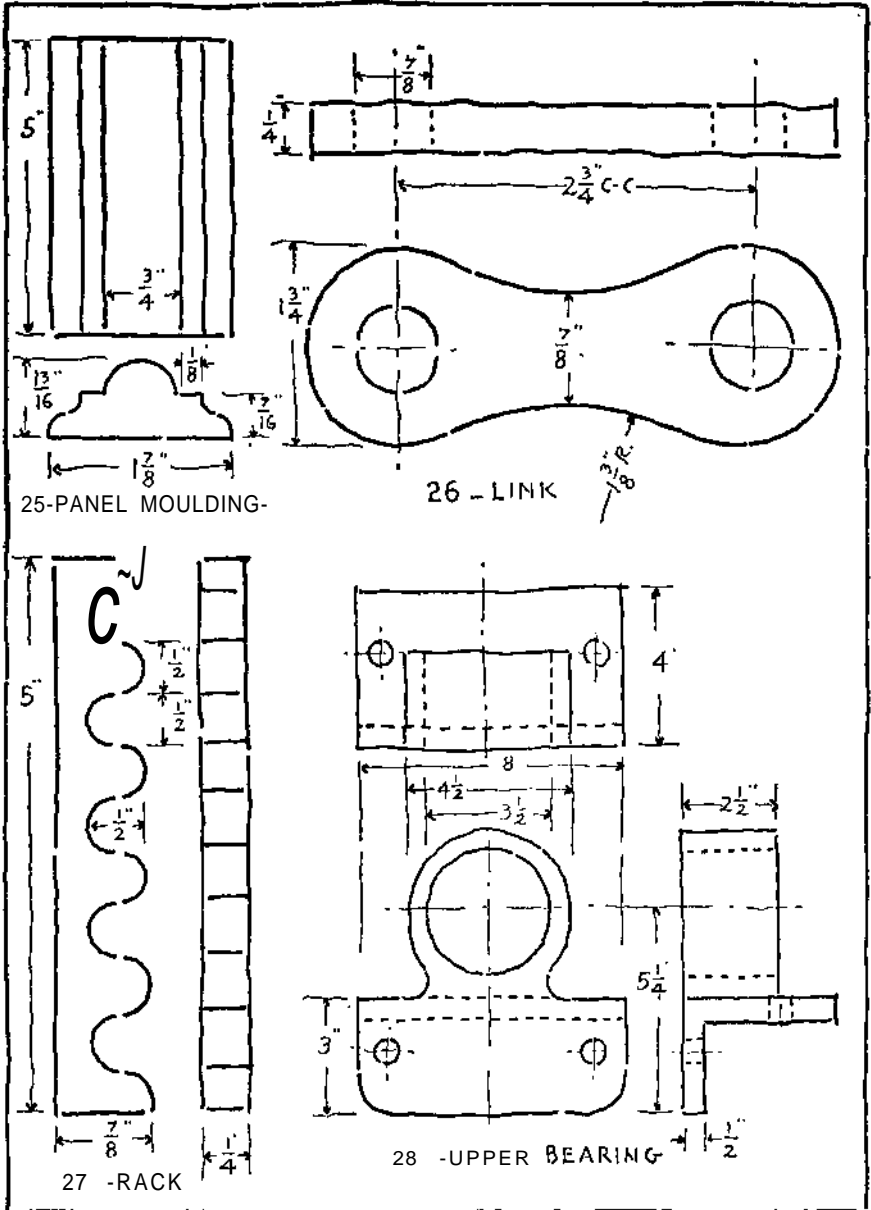
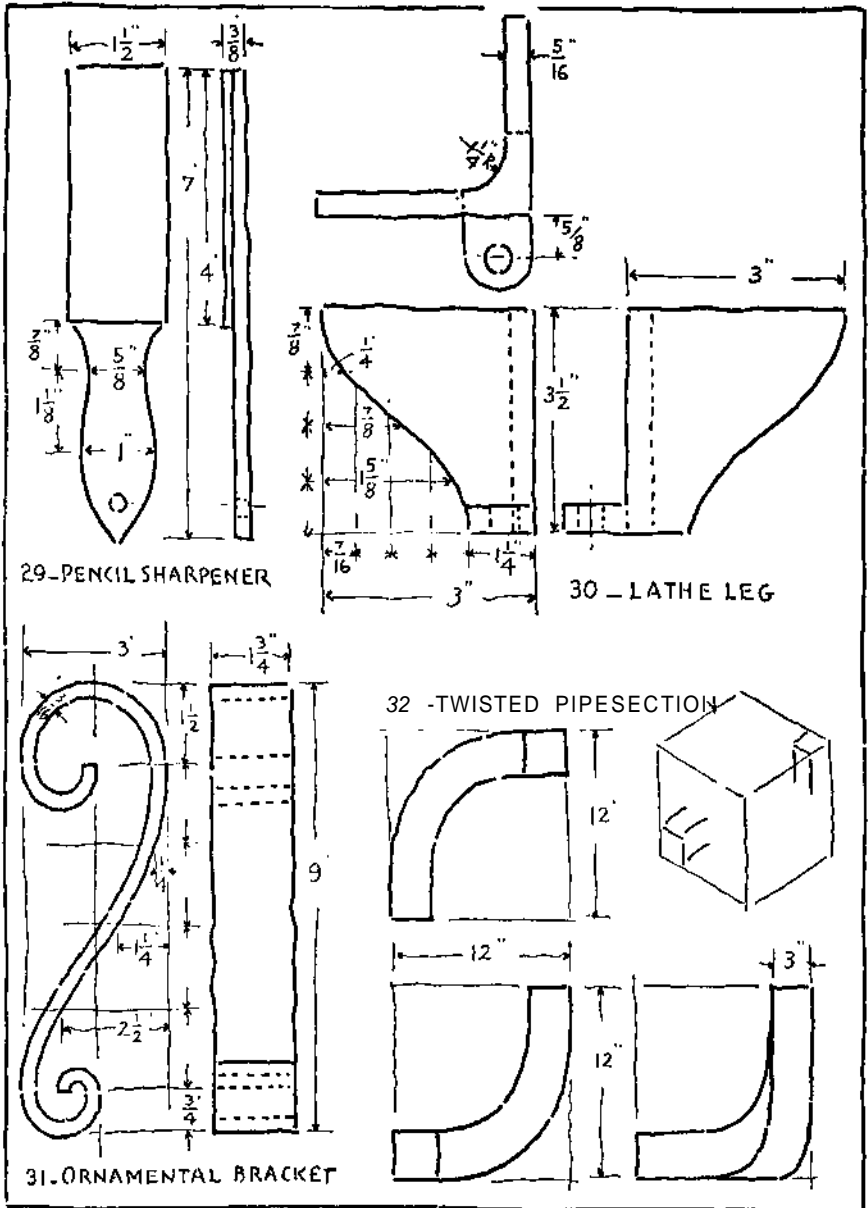

PLATE 66. Problems 19 to 24.





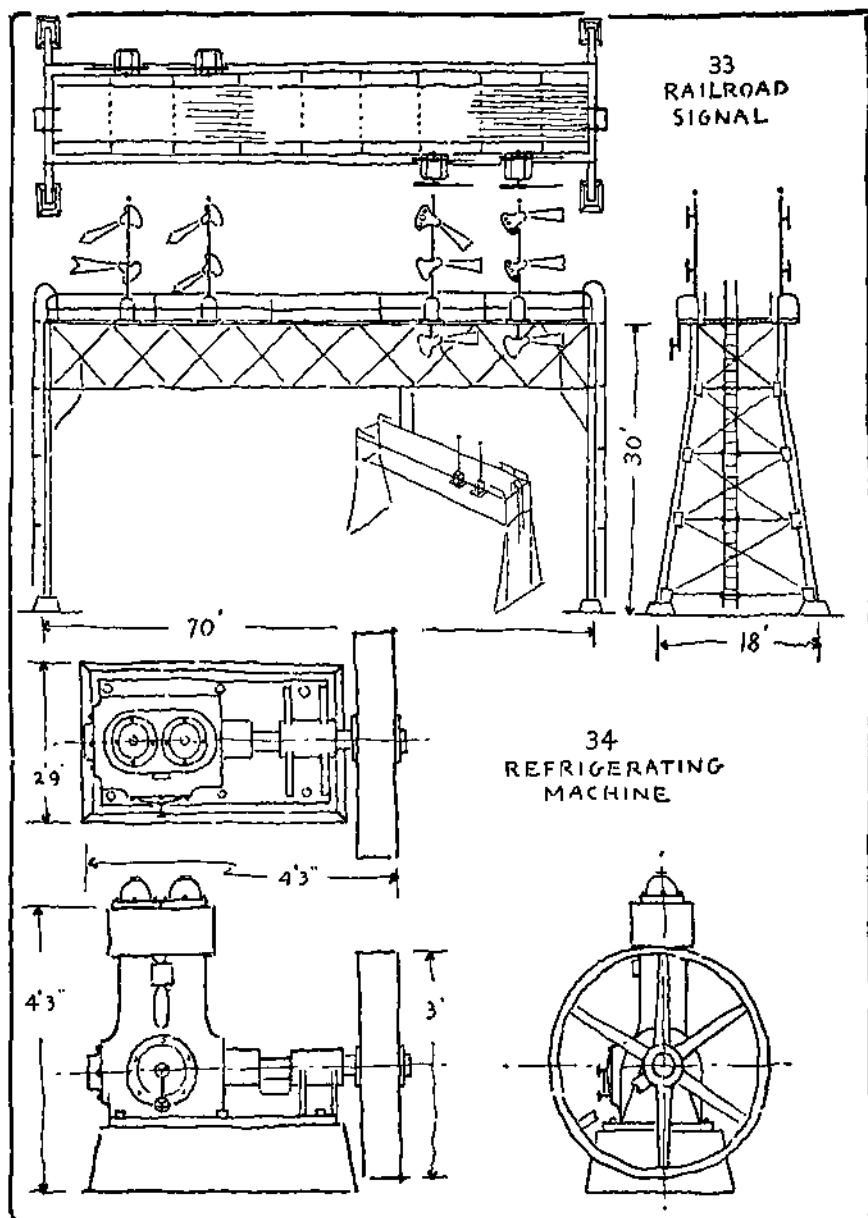

PLATE 69 Problems 33 and 34.

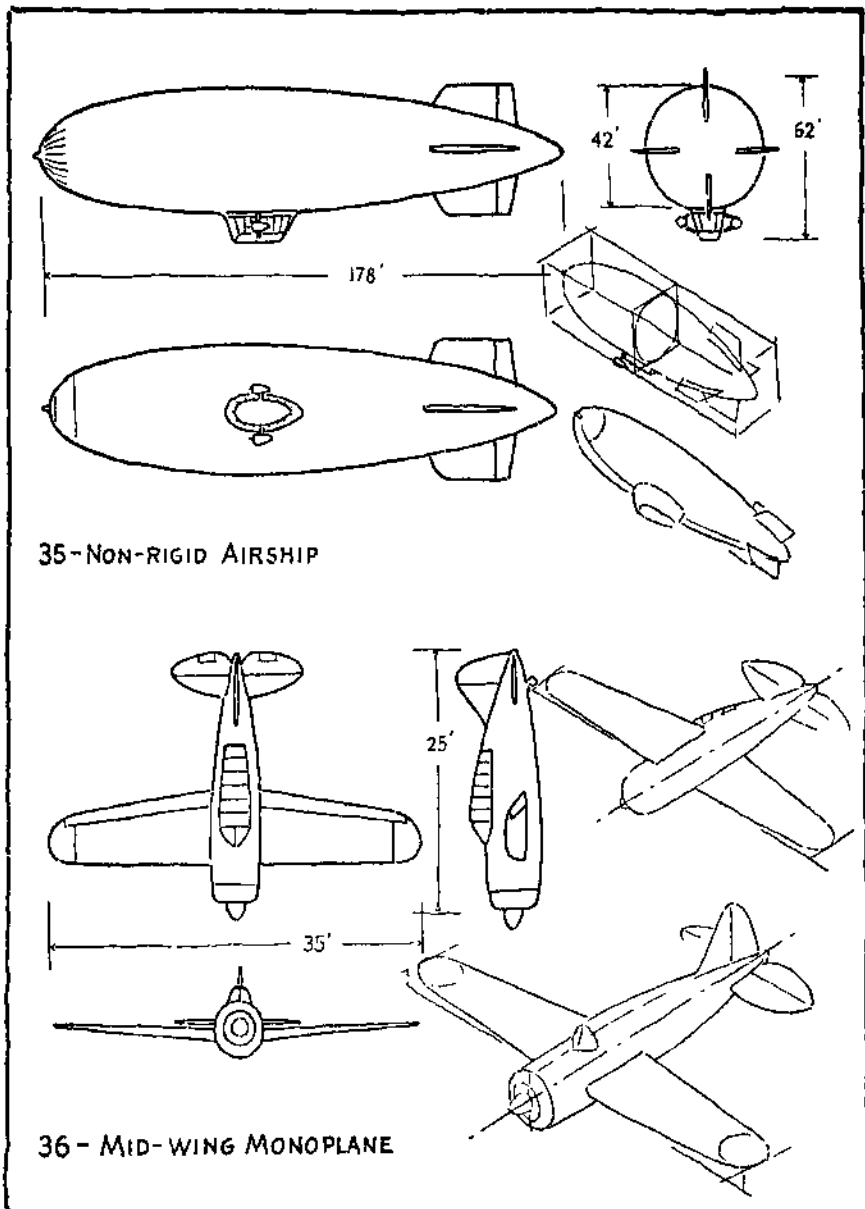

PLATE 70 Problems 35 and 36.

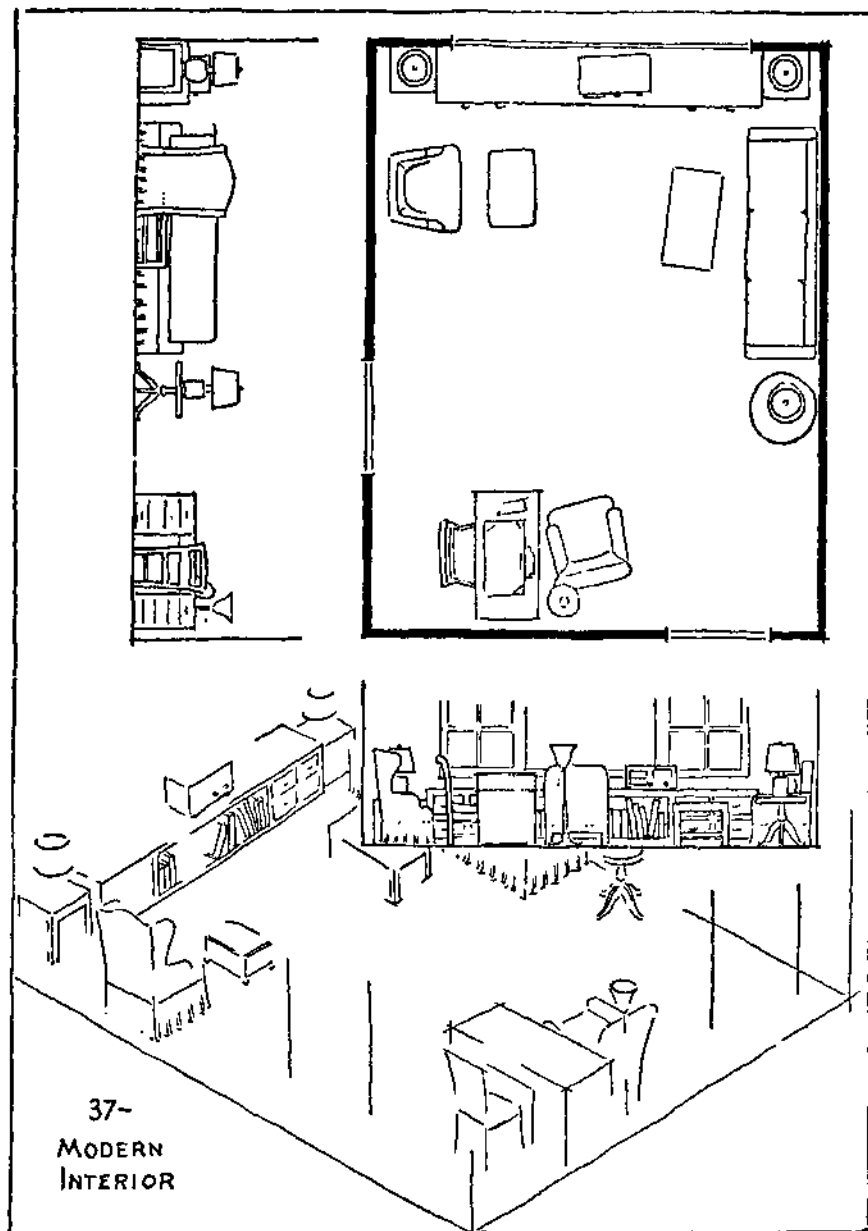

PLATE 71. Problem 37.

ASSEMBLY VIEWS

When a machine or construction is made up of a number of parts it is often necessary to make a drawing to show where the parts are located, to show how they are put together, to show how they operate, to show how much space is occupied, to give foundation or erection information, to give piping, wiring or other installation dimensions, to show the appearance of the complete machine or construction, either from the outside or in section, and to give other necessary information having to do with the assembling of the parts. Such a drawing is called an assembly drawing or an "assembly."

On Plate 73 details are shown at Fig. A and an outline assembly at Fig. B. On Plate 74 an orthographic sectional assembly is shown at Fig. A and pictorial diagram assembly at Fig. B.

Assembly Drawings and Sketches. — The purpose for which an assembly drawing is to be used will determine the method of representation and the character of the treatment. If orthographic projection is used (Chapter 4) three views, top view or plan, front elevation, and side elevation are the usual views; Fig. A, Plate 72. Where the side elevations are not the same, a fourth view may be added to show the differences. Sometimes a bottom view is necessary in addition to the top view or plan. For some purposes one or two orthographic views are sufficient for a particular purpose.

Assembly drawings do not follow any set rules as to treatment or amount of detail to be shown. They vary from severe outline views which omit center lines, hidden lines, dimensions, lettering, etc., to working assemblies which include a complete representation of all the parts with dimensions and notes. Assembly drawings may

show some or all the details in section, may use phantom views, may be shaded, or may have a variety of treatments.

Special Assemblies and Layouts. — Aircraft drafting, ship drafting, and sheet metal layout drafting frequently disregard certain of the principles of projection. Drawings of ships and sheet metal assemblies often follow the practice of superimposing the elevation on the top view or plan. Or the elevation may be placed above the top view or plan (first angle projection). Aircraft assembly drawings may have the views arranged to use the space available without regard to the projection from one view to the others. Such variations from true projection do not make it difficult to read the drawings as airplanes have three distinctively different outlines or silhouettes and can be identified. A study of airplane outlines in the field of aircraft spotting can be quite independent of mechanical drawing or sketching principles.

Pictorial Assemblies. — One-view assembly drawings or sketches made in pictorial form are finding increasing use. For many purposes they are more easily understood than the three views made in orthographic projection. Pictorial methods of representation mentioned in Chapter 5 include perspective, isometric, and oblique drawing. The principles of isometric drawing are used in this book as they are simple, easily applied and are generally effective for most industrial and manufacturing purposes. Isometric drawings or sketches are employed to translate the regular three-view drawings into pictorial views. Positions can be assumed to show three " faces " of the project: top, front, and right; top, front, and left; bottom, front, and right; bottom, front, and left. Such pictorial drawings and sketches can be read by workmen who are unskilled in reading regular projection drawings; Fig. B, Plate 72.

In the preparation of drawings and sketches for the weapons and machinery of war, isometric assemblies have achieved a more extended use than in the usual industrial fields enumerated in Chapter 8, Isometric Sketching.

"Exploded" Assemblies. — Pictorial drawings and sketches of multi-part constructions and machines are sometimes made in a manner to represent a dissection or explosion of parts. Such an exploded assembly is illustrated in the frontispiece and in Fig. C on Plate 72. Thus a multi-part construction as a building, an excavator, or an airplane can be represented in an isometric sketch or drawing (or in true perspective) with the individual parts or groups of parts spread out or separated from each other but in position to be moved together. Such exploded assemblies are in the nature of explanatory detail drawings and they are a positive advantage in shops where semi-skilled workers and others who are unfamiliar with blueprints are employed. Manufacturers of gyroscopes, airplane valves, airplanes, and in general the whole aircraft industry have adopted this practice to a considerable extent.

Analysis of Isometric Assembly Drawings. — The translation of a three-view assembly into a pictorial assembly sometimes may appear to be difficult. In such cases consider the basic geometrical shapes of the more important parts as well as the general enveloping form of the whole construction. This means to sketch the containing outline proportioned to the over-all dimensions, then sketch rectangular prismatic forms in the proper locations, and "whittle" them down to the cylindrical, pyramidal, conical, or other shapes and modifications of such solids. In this way it will be found to be a comparatively simple matter to produce a finished and satisfactory pictorial assembly. See Fig. D, Plate 72.

Sketching Large Assemblies. — Correct proportions in relation to the main dimensions of an assembly are as important and necessary in the representation of large constructions — a lathe, an airplane, a warship, or a "skyscraper" — as for a simple small casting.

When sketching from an existing construction of large size the proportions can be readily obtained by pencil measurement. To get the comparative length and height, hold a pencil at arm's length, and move the thumb up or down until the space between the top of the pencil and the thumb nail just includes the vertical dimension

and do the same with the horizontal length. Then compare the two distances and estimate the number of times (or fraction of times) one distance can be repeated in the other one. This is clearly shown step by step in Fig. E, Plate 72.

Isometric assembly sketches which have dimensions in one direction long in comparison with the others, can have the apparent distortion effectively reduced by making the lines parallel to the long dimension converge a slight amount as indicated in Fig. F on Plate 72.

Problems. — The exercises which follow are intended for use as substitutes for actual planes, motor cars, etc., in order to provide the practice which is necessary to make use of the principles explained in this chapter. Sufficient graphic information is given for the adequate sketching of general over-all assemblies. These exercises should be supplemented by making sketches of actual machines and constructions. It should be borne in mind that considerable time and care are required to make suitable assembly sketches, either pictorial views or orthographic views.

PROBLEMS 1 to 7, PLATES 75 to 80. — Isometric pictures are given from which views are to be sketched in orthographic projection. Where it is more convenient, place the views without regard to usual positions as explained in the article on "Special Assemblies and Layouts." Satisfactory proportions can be obtained by applying the method of pencil measurement (illustrated on the small sketches of Plate 72) to the main dimensions of the drawing.

PROBLEMS 8 to 11, PLATES 81 to 84. — Orthographic or multi-view drawings are given from which isometric type pictorial sketches are to be made. The instructions given in Chapter 8 should be reviewed with particular attention to non-isometric lines, circles, and irregular curves. In a plane, the angle of a trailing edge, a leading edge, taper, and dihedral of wings and tail, are of major interest. They may be the only distinguishing features of two otherwise similar aircraft. Recognition of these points of difference will help in producing a good isometric pictorial sketch. When necessary, make pictures as viewed from above and from below. Reversed axes, as described in Chapter 8, are to be used when the view is sketched from below the plane.

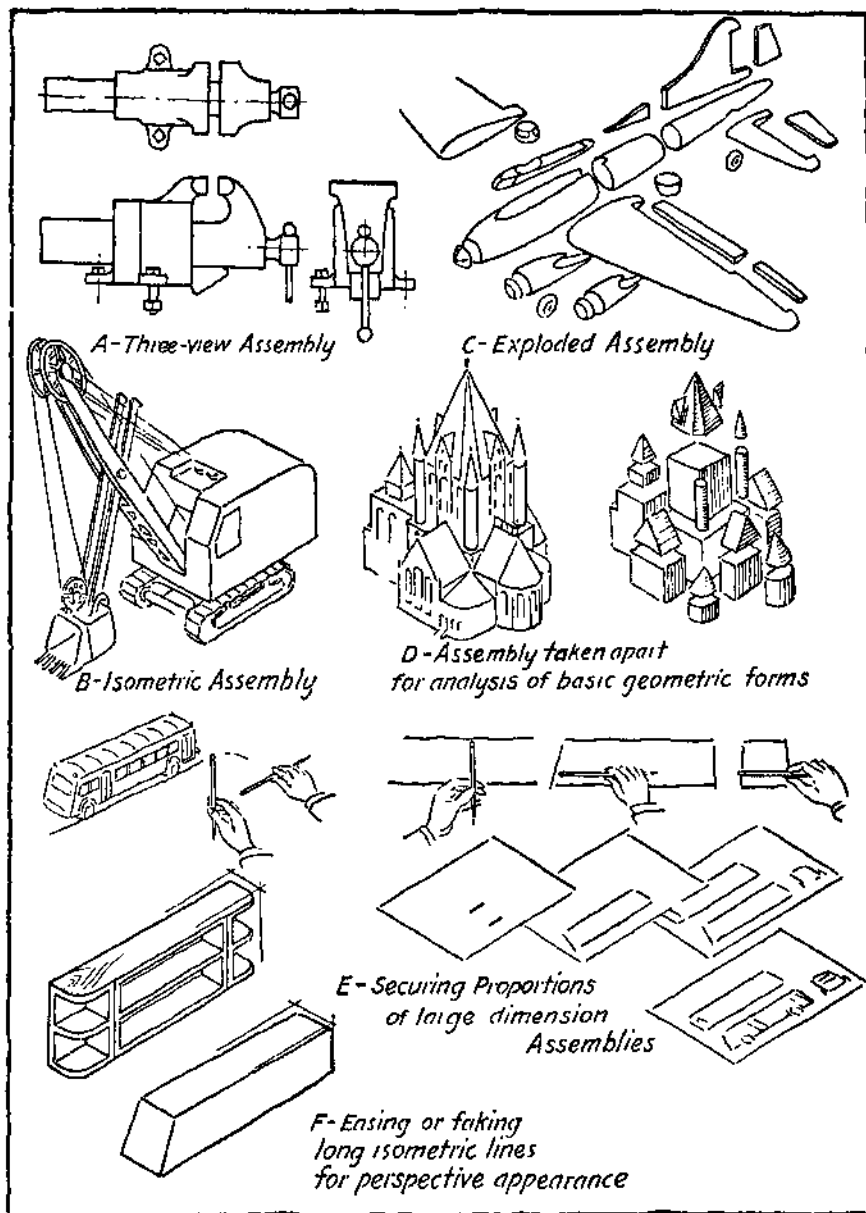

PLATE 72 Assembly View Sketching.

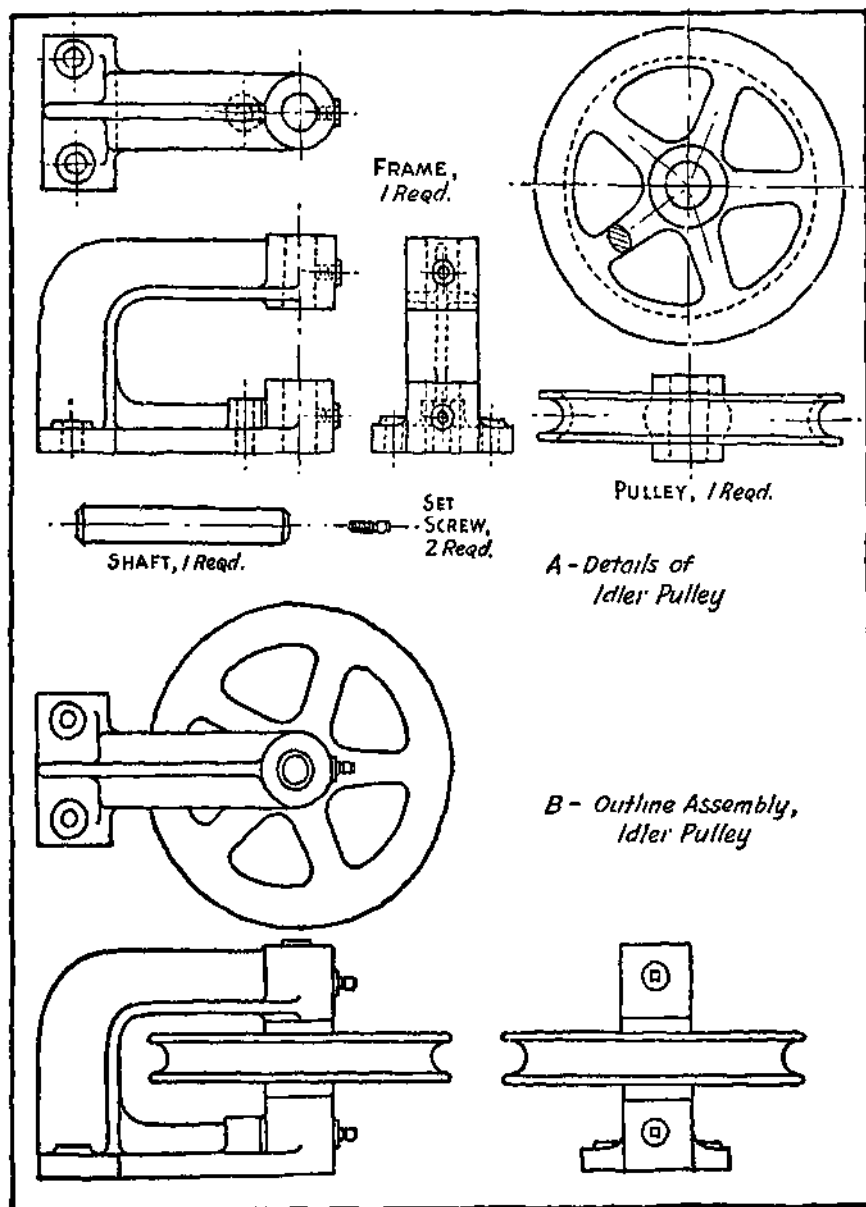

PLATE 73. Detail and Assembly Sketching.

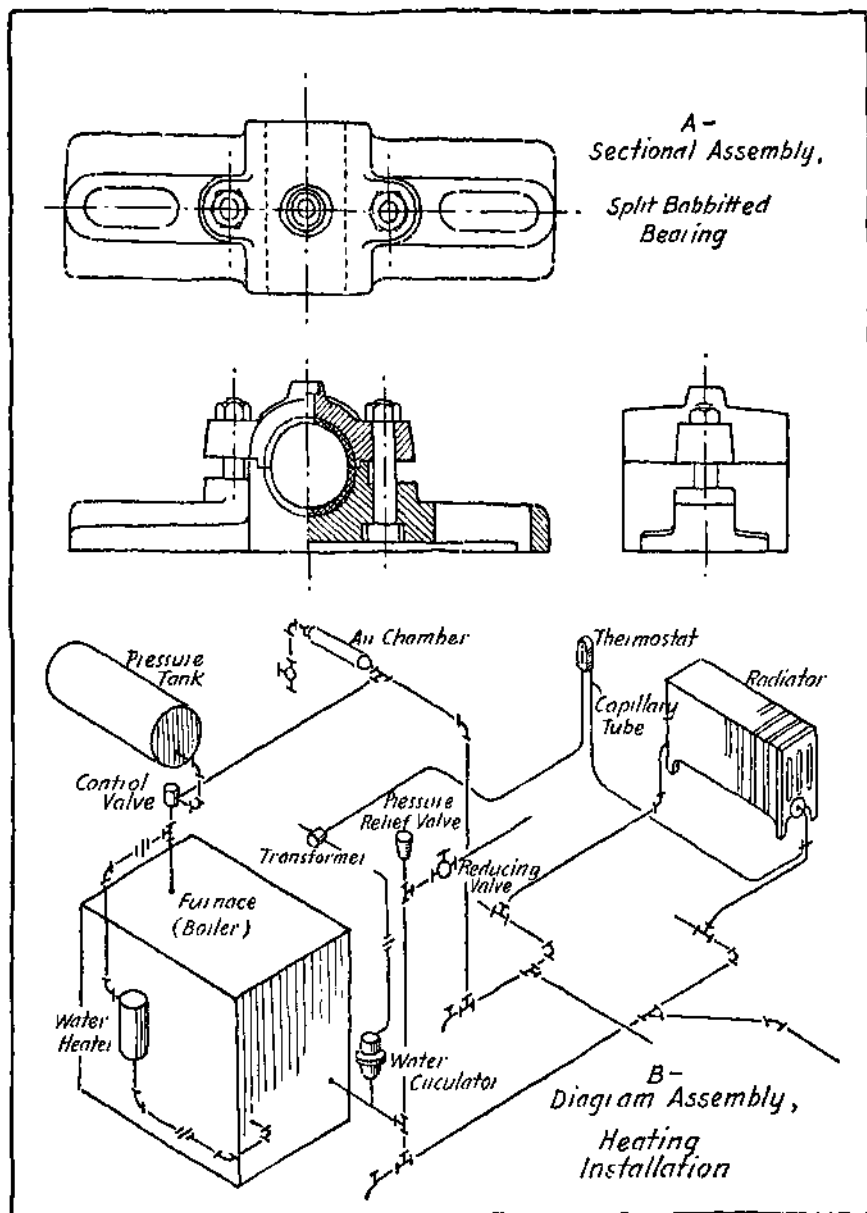

PLATE 74. Sectional and Diagram Assemblies.

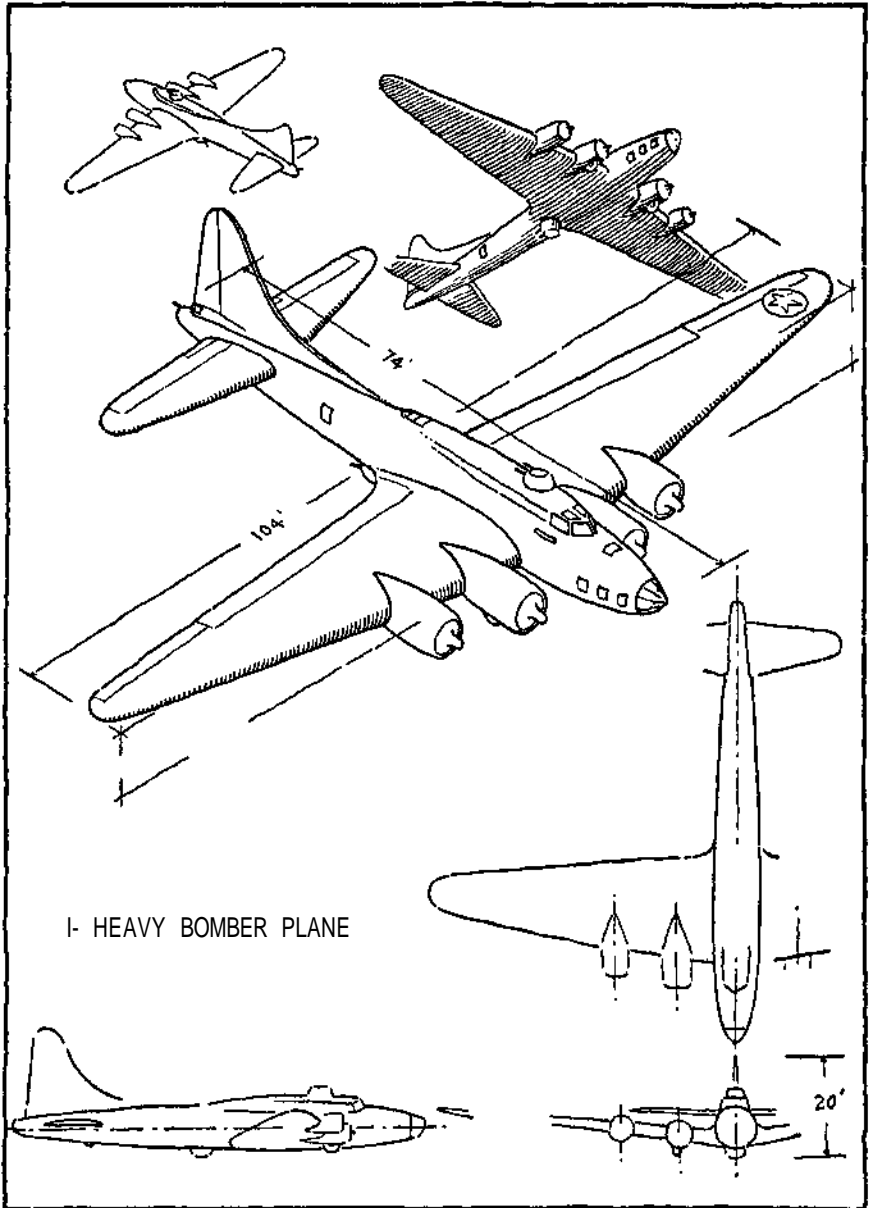

PLATE 75. Problem 1.

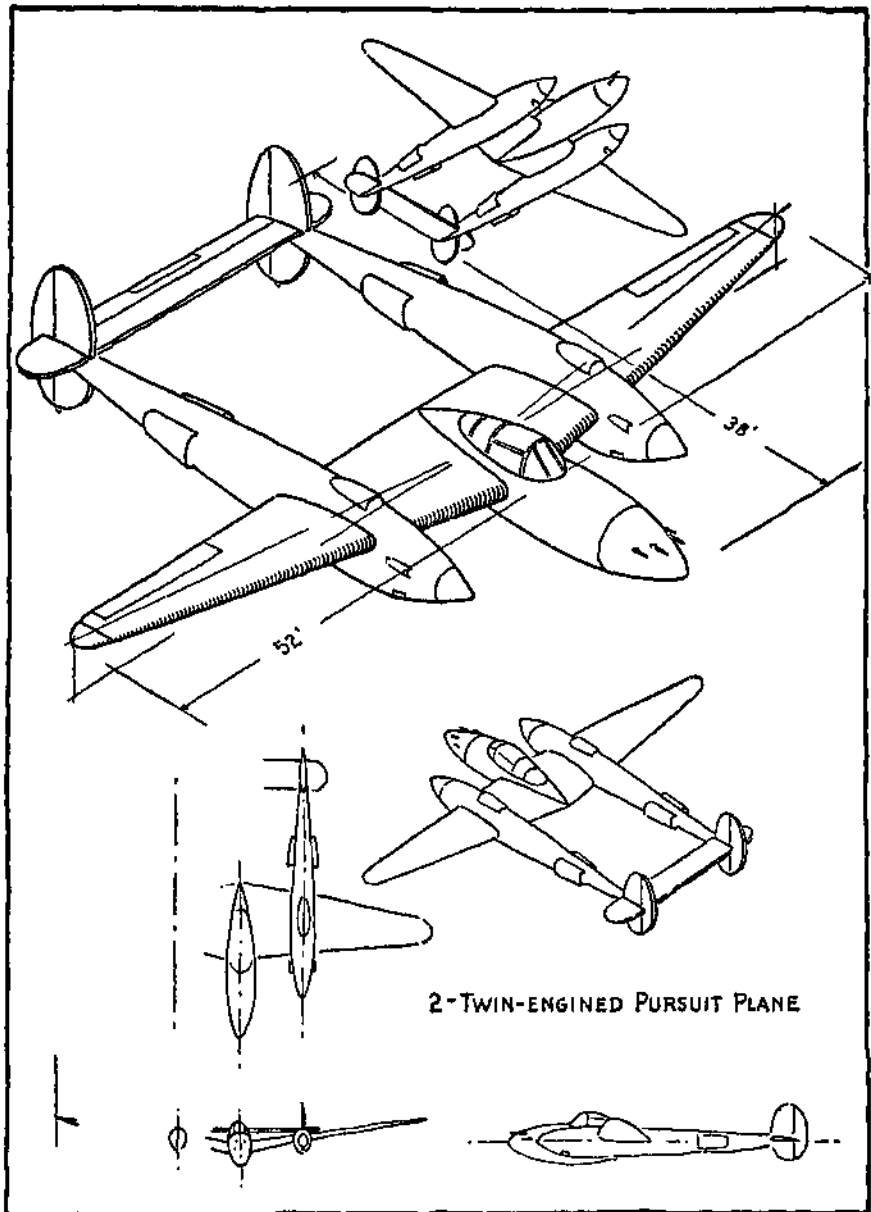

PLATE 76. Problem 2.

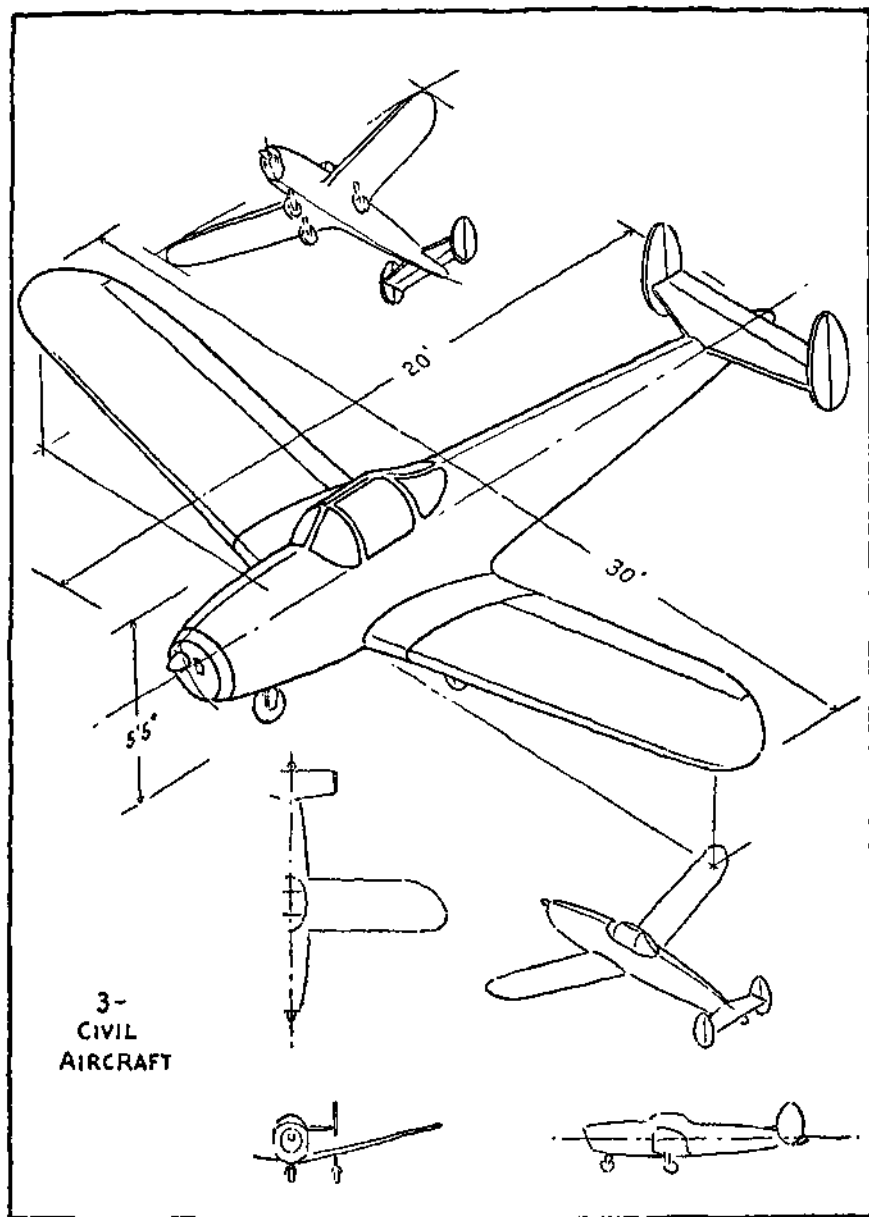
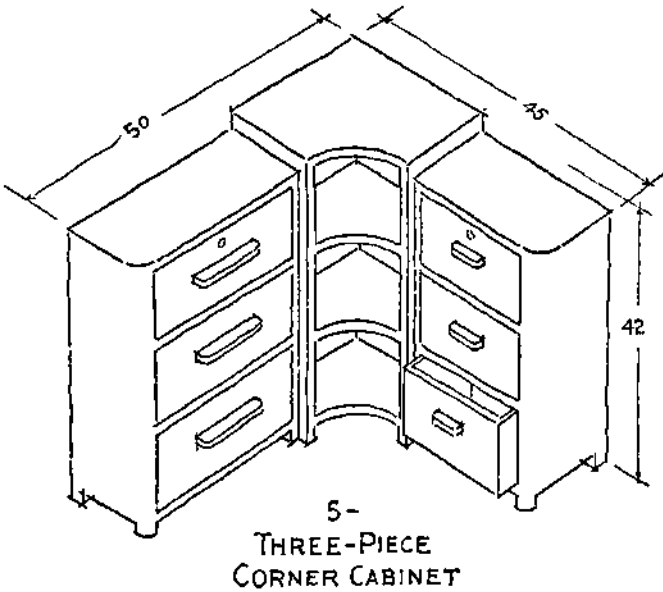
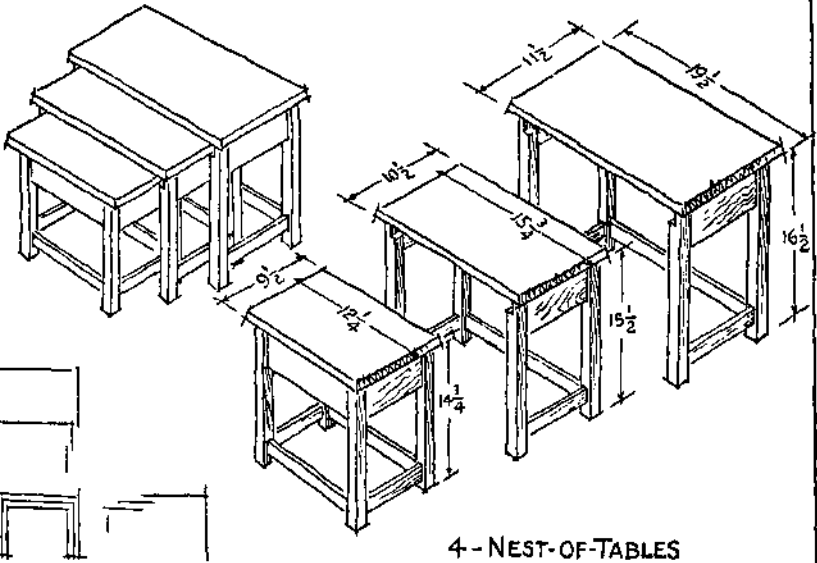

PLATE 77. Problem 3.



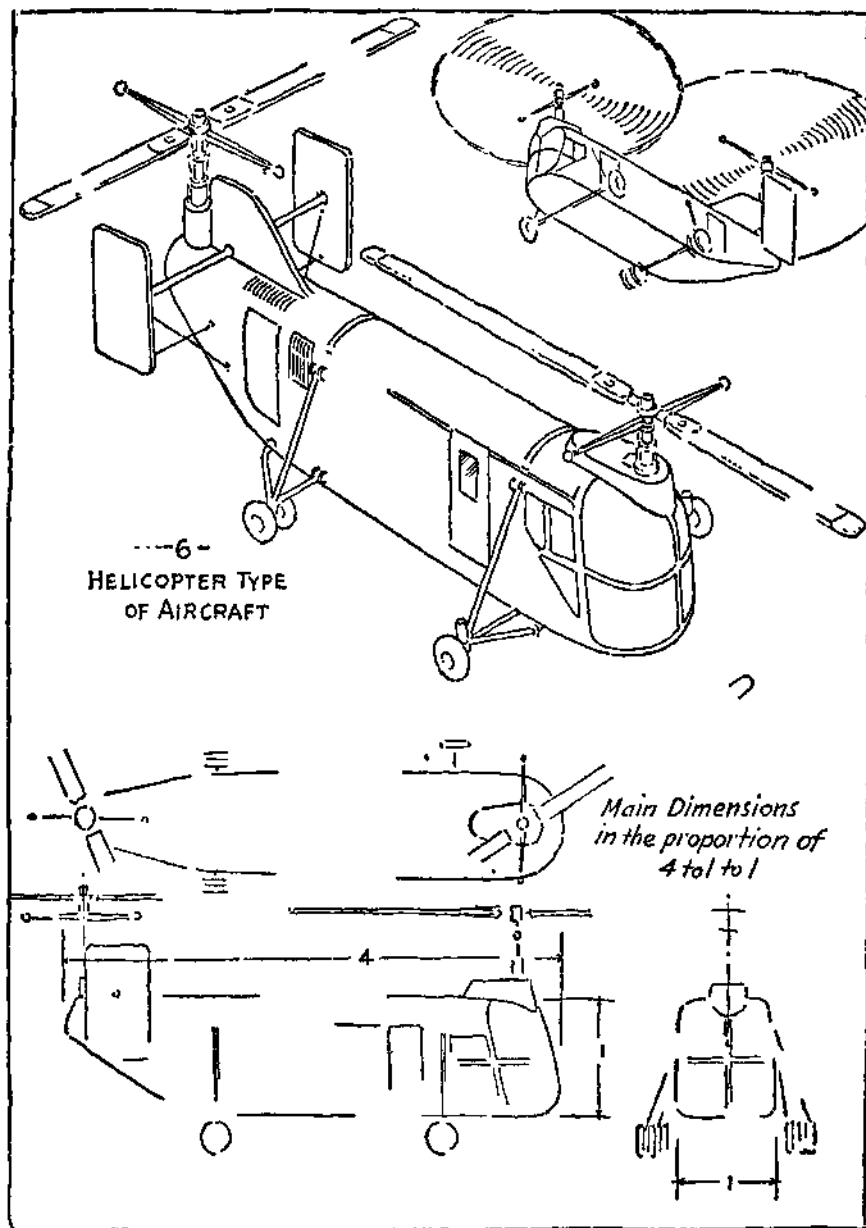

PLATE 79. Problem 5.

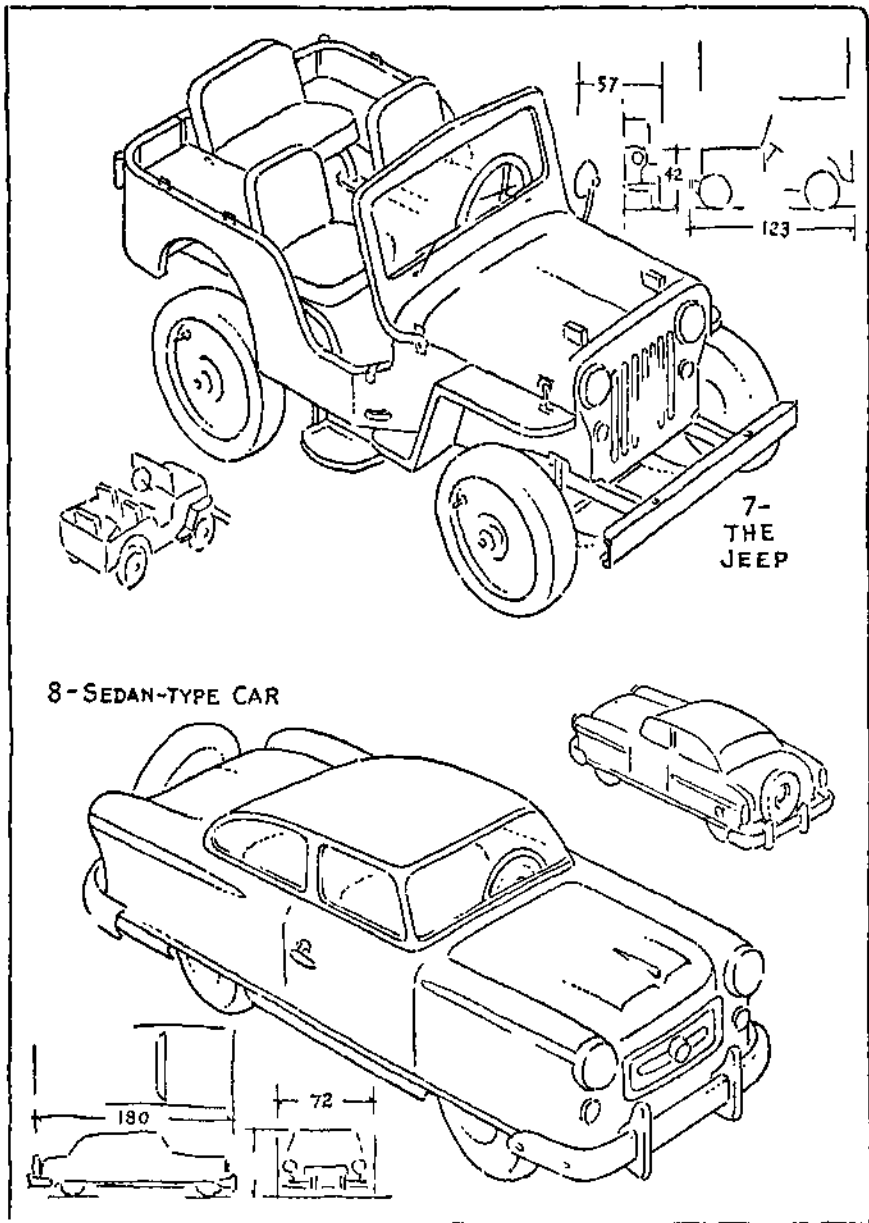

PLATE 80. Problems 6 and 7.

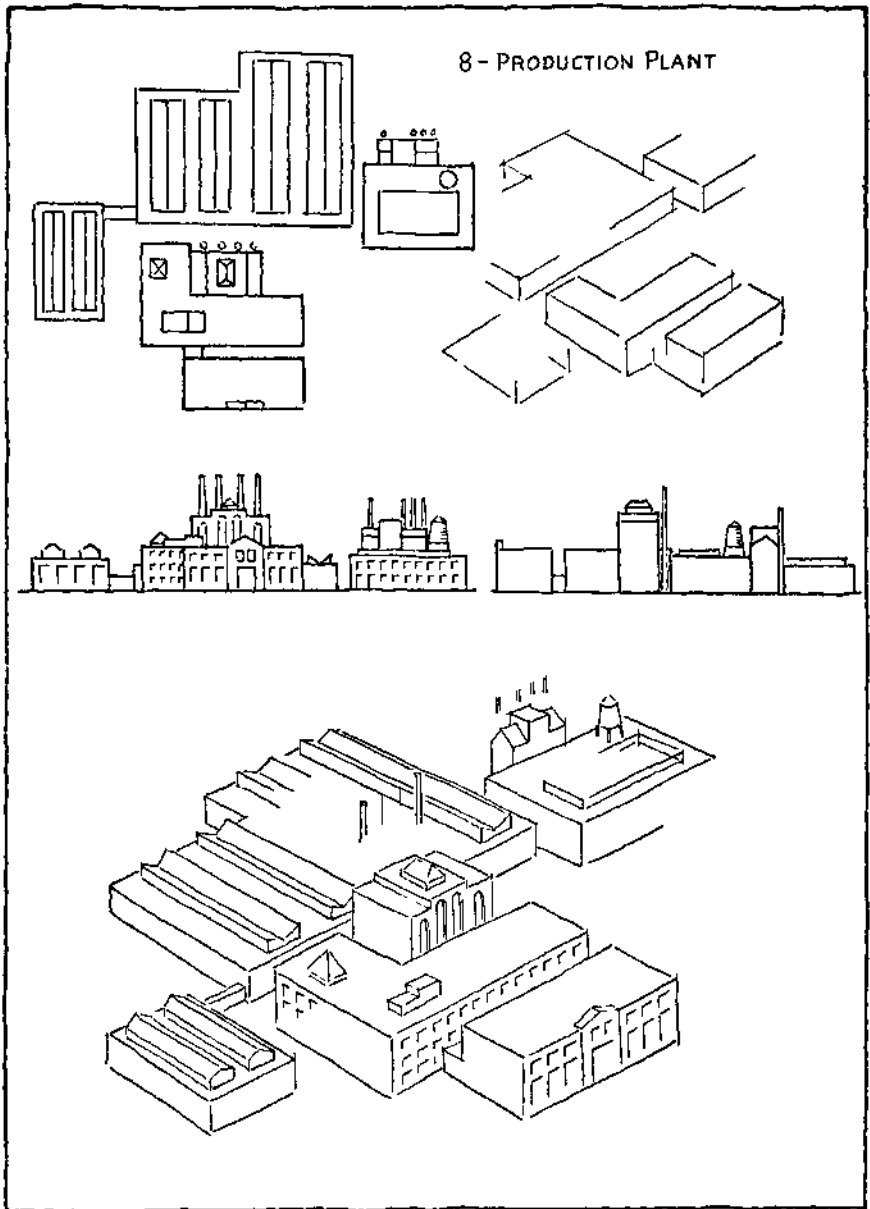

PLATE 81. Problem 8.

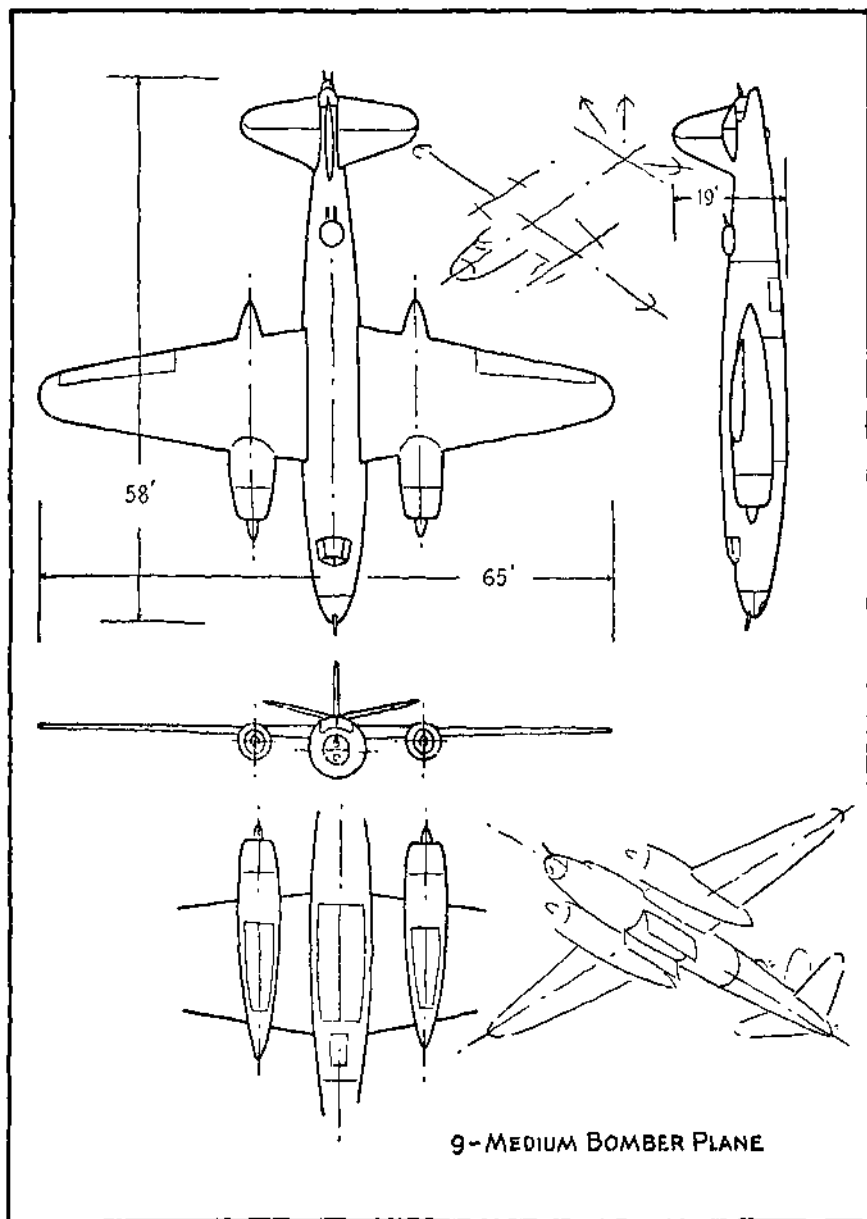

PLATE 82. Problem 9.

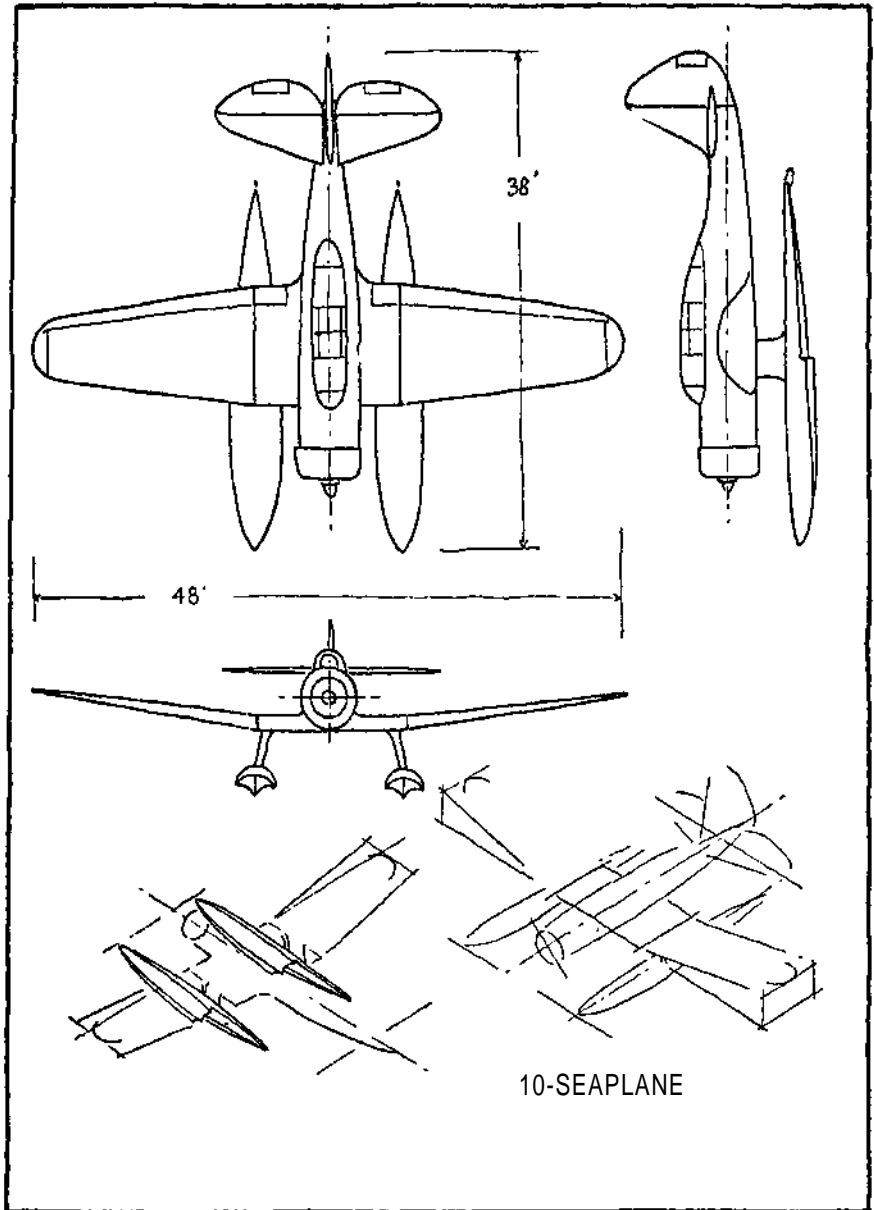
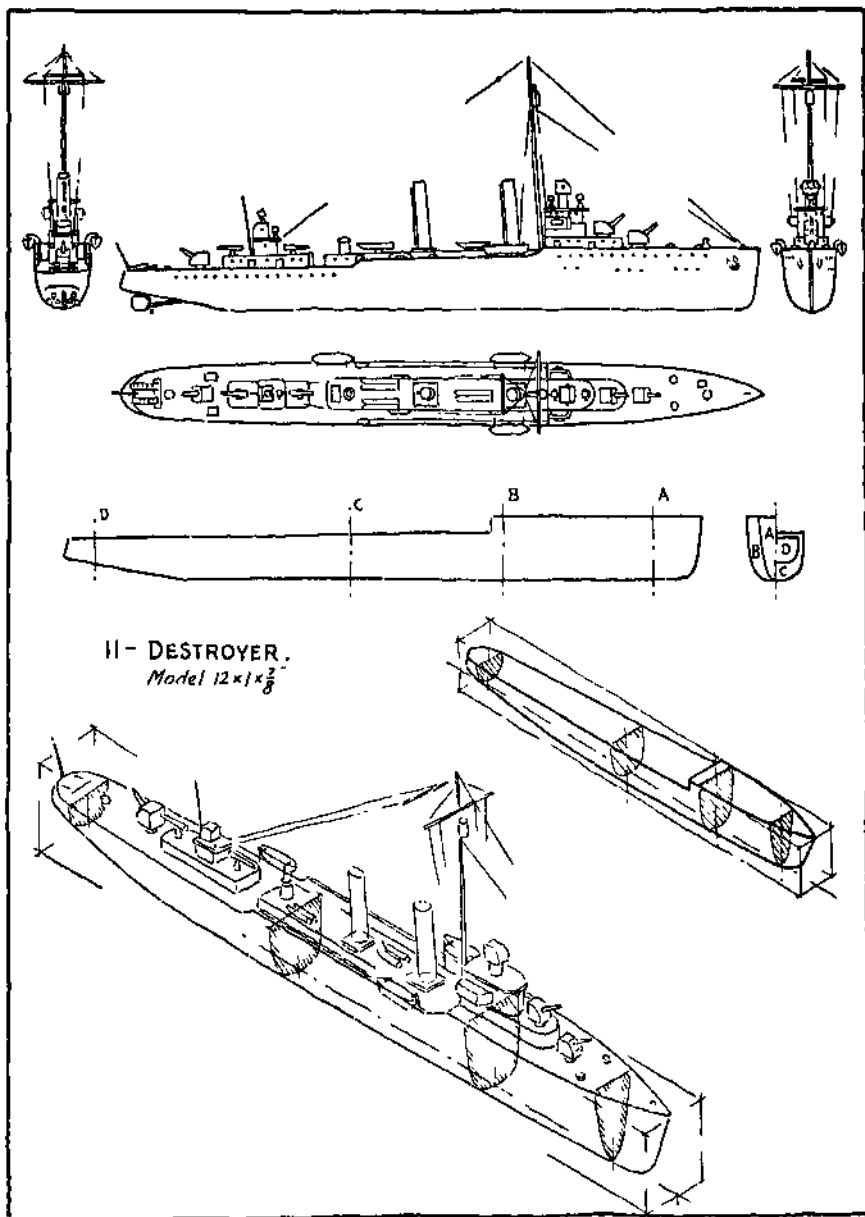

PLATE 83, Problem 10.



II - DESTROYER.
Model $12 \times 1 \times \frac{3}{8}$

PLATE 84. Problem 11.

MEMORANDA

10

PRODUCTION ILLUSTRATION

Production illustrations or production drawings are pictorial drawings to show the shapes, sizes, and operations for details and assembled constructions. These are used instead of the traditional three-view or multiple-view (projection) mechanical drawings for many purposes.

International economics and global conflicts have given a tremendous impetus to this comparatively new way of describing mechanical objects. Although production illustration is not a general substitute for the usual projection drawings it has nevertheless been accepted as a practical method by the engineering world.

Production illustration comprises mostly pictorial technical drawings made in perspective, in isometric, or in a modification of these methods. Such mechanical pictures (hence the term *illustration*) are made in a number of forms and may be shown as sections or part sections, as cutaway views, as phantom or X-ray views, as diagrams, or in dissected form, pulled apart or as now universally termed, *exploded*.

Exploded Drawings. — As pointed out in the chapter on Assembly Views, exploded drawings are fundamentally pictorial assemblies with the separate pieces accurately lined up and spaced short distances apart as shown on Plates 85 and 86. In some uses of production illustration such as aircraft drafting a single job or complete assembly may be so intricate that extra drawings called sub-assemblies must be made to show a break-down of the many parts of such structures. Because of the artistic character of drawings made for production illustration, the draftsman undertaking such work is known as a technical illustrator. It is prevailing

practice to refer to the technical illustrators who do the work of exploding from a projection drawing to an isometric drawing as both a visualizer and an isometric draftsman or isometrician.

Uses of Production Illustration. — Many production and exploded drawings are shaded in various ways and by different techniques so that they are both artistic and realistic. Such treatment adds to their readability. Since they are admired and so easily comprehended, they have been introduced into manuals of various kinds labeled: Sales; Service; Manufacturing; Erection; and Repair. Other applications include: Government Instruction Books, Parts Lists, Instruction Sheets, Catalog, and Hand Books.

Procedure. — There is no completely standardized or uniform method of exploding drawings. An inspection of various pamphlets and reproductions from different sources will show the individual practices of different technical illustrators.

In the problems to be worked, Plates 85 and 86 in this chapter show the assembly and detail drawings as generally made by the draftsman, at A and B.

Directly below these drawings, at C, the assembled construction is laid out (exploded), or pulled apart a convenient distance to show the top, sides, slats and fastenings. On Plate 86, the Quick Acting Chuck is treated in the same manner. An isometric view is also included.

Problems.—The five illustrations, numbers 3 to 7, are laid out in the same way as numbers 1 and 2 with some suggestion of isometric appearance or dissection of the various parts.

PROBLEM 1, PLATE 87. — Visualize and explode from the assembly and details the BOLTED FIXTURE. A partial isometric and suggested layout are included as an aid.

PROBLEM 2, PLATE 88, — Visualize and explode the FLANGED FITTING.

PROBLEM 3, PLATE 88. — Visualize and explode the LATHE SCRIBER.

PROBLEM 4, PLATE 89.—Visualize and explode the CONDUIT CLAMP. A hint on dissecting the gadget is included.

PROBLEM 5, PLATE 90.—Visualize and explode from the three-view drawing and part isometric, the ROUTING JIG.

Other examples for exploding simple assembly drawings are:

PLATE 40. —TABLET and BIRD HOUSE.

PLATE 54. — UNION and SPARK PLUG.

PLATE 73. — IDLER PULLEY.

PLATE 74. — SPLIT BABBITTED BEARING.

PLATE 91. — SHAFT COUPLING.

PLATE 95. — WALL BRACKET.

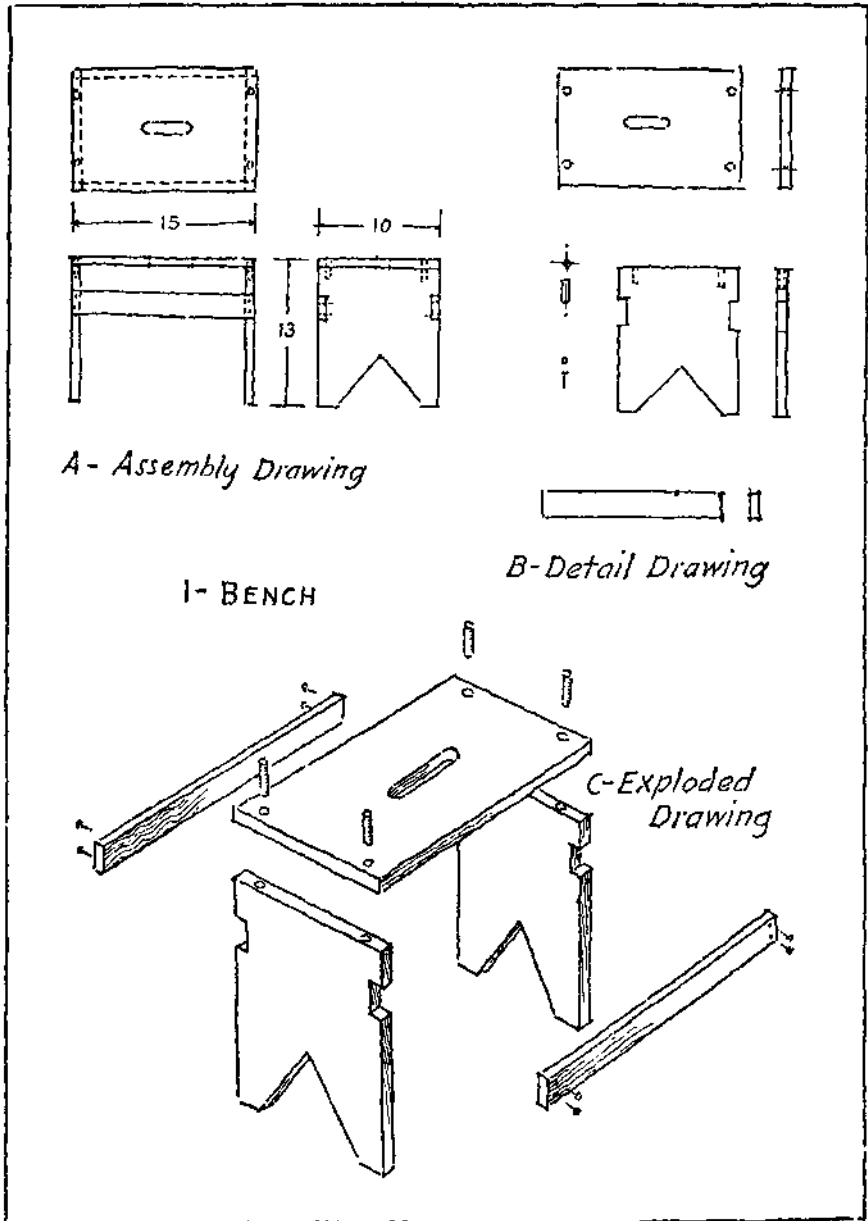

PLATE 85. Exploded Drawing.

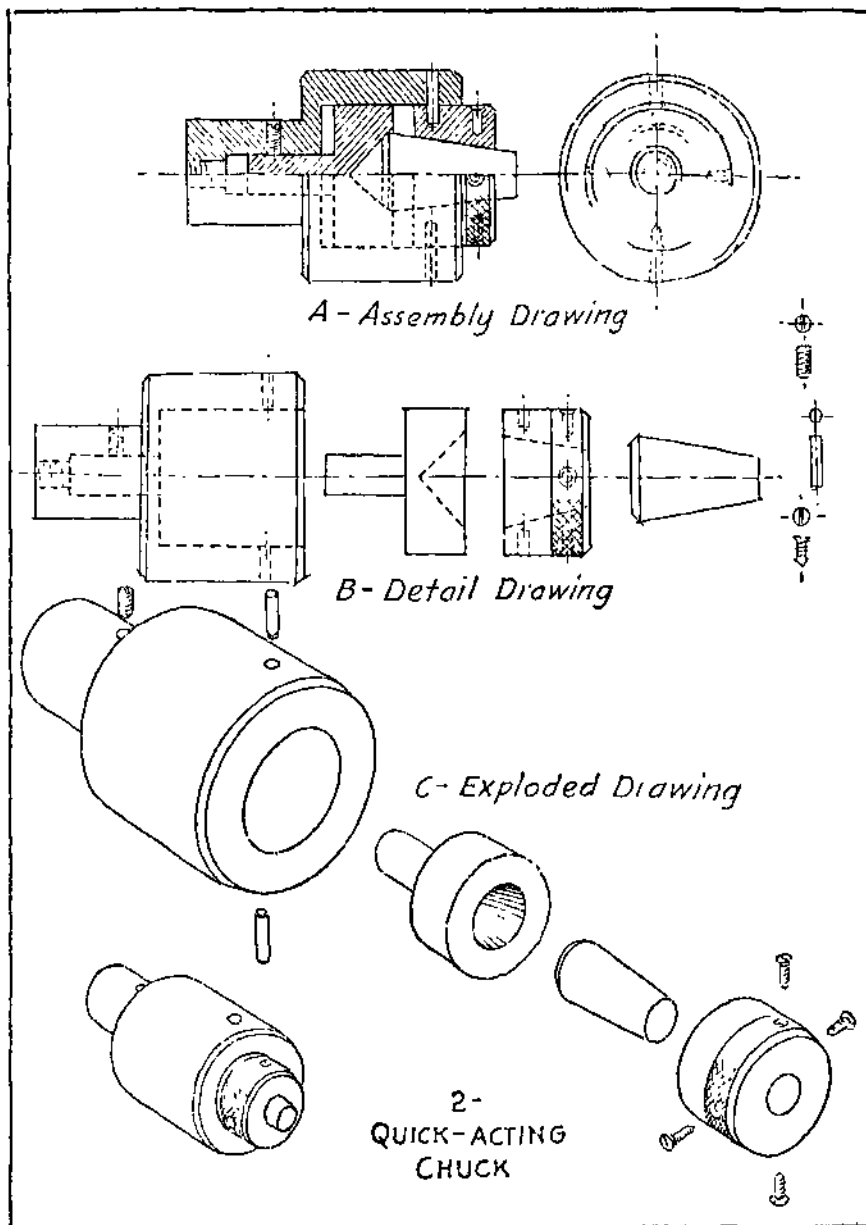

PLATE 86. Exploded Drawing.

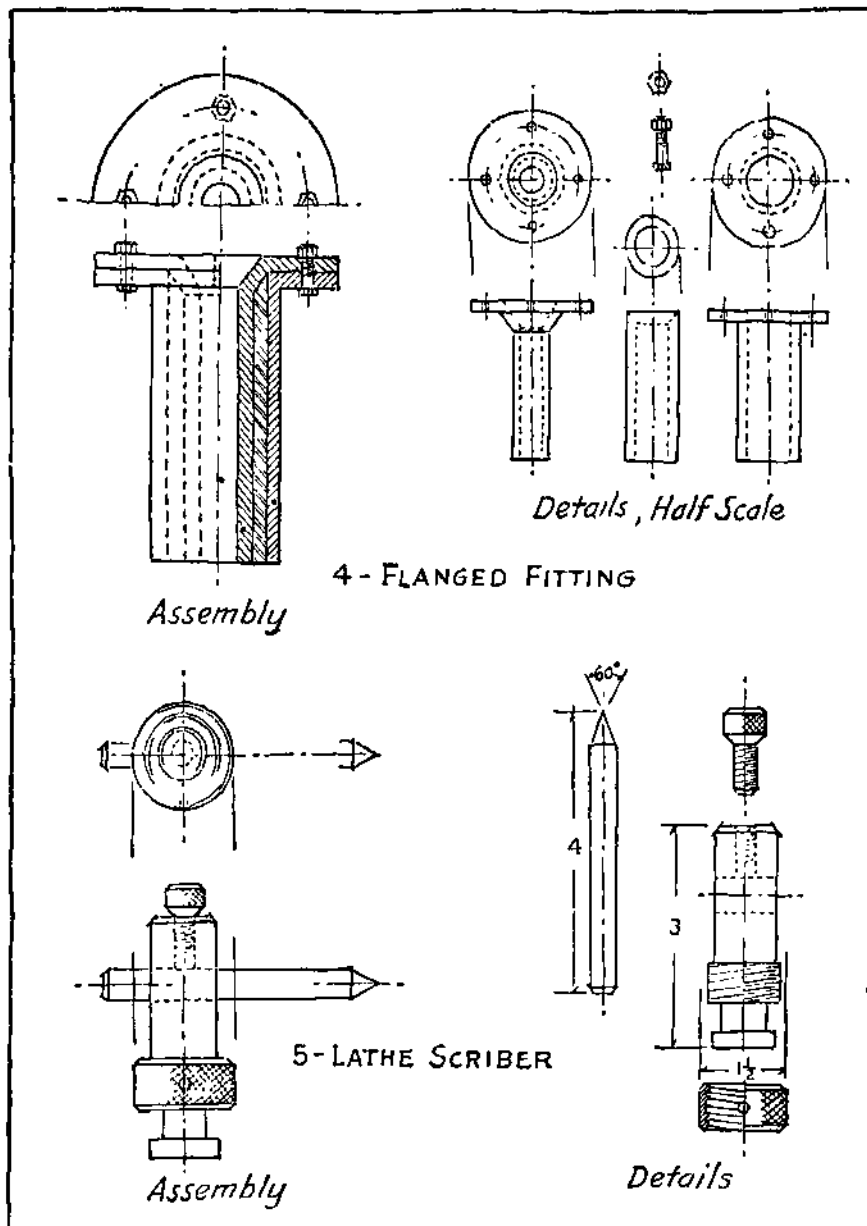

PLATE 88. Problems 2 and 3.

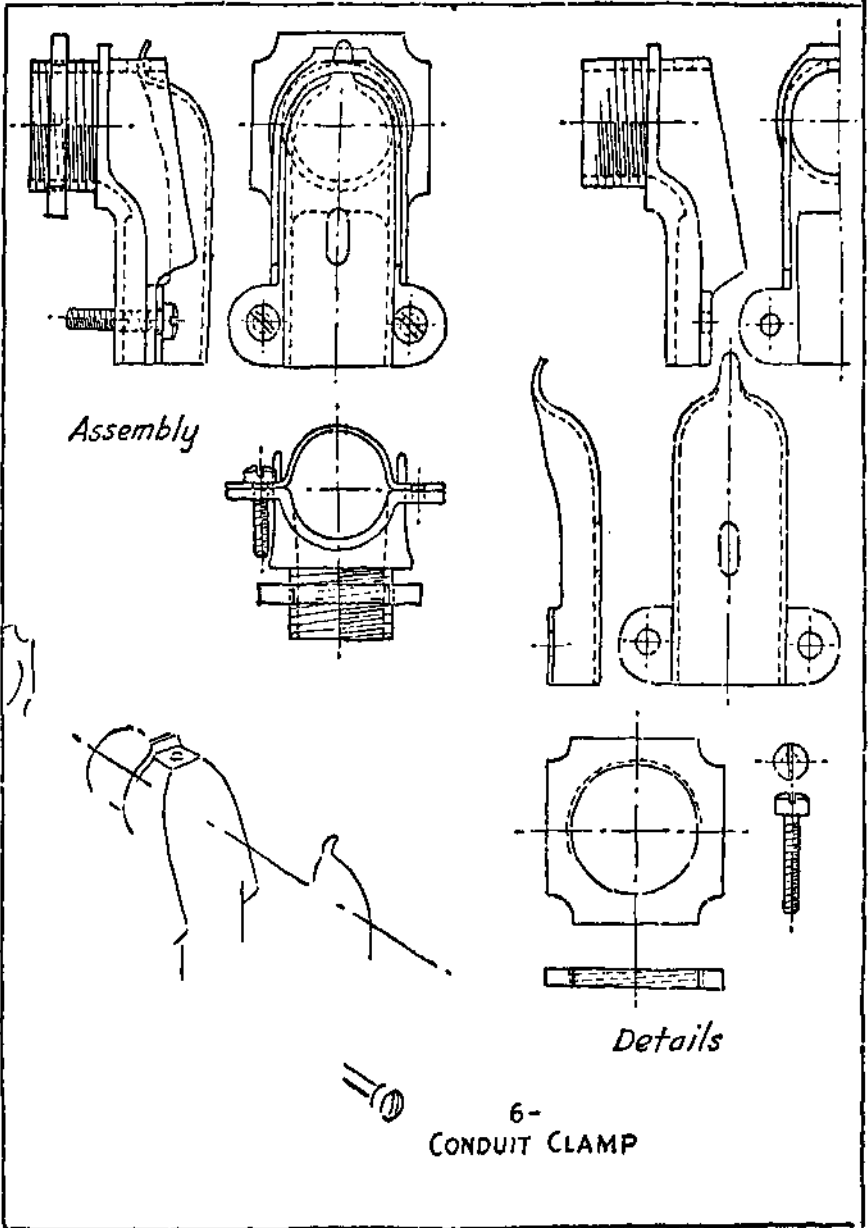

PLATE 89. Problem 4.

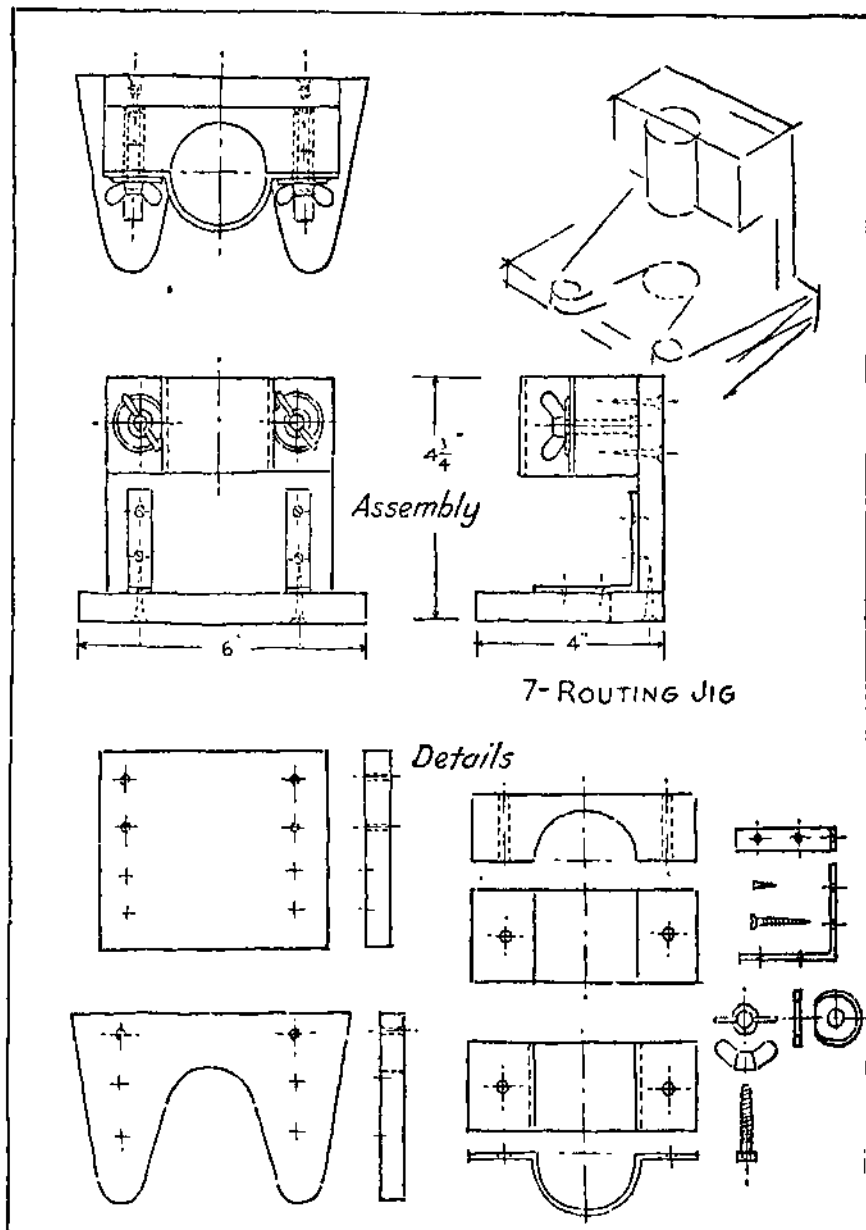

PLATE 90. Problem 5.

MEMORANDA

SHADED SKETCHES AND DRAWINGS

While shading is no longer used on working drawings, it is still used on certain classes of drawings where a pictorial effect is desirable.

Uses of Shaded Drawings. — Shading is sometimes used on assembly drawings to make it easier to distinguish the different parts, especially when only one principal elevation of a machine or structure is made. It is helpful at times on shop sketches to bring out the shape quickly and clearly. Drawings for trade and technical journals, catalogs, and for similar purposes are often shaded. They are not only more attractive in appearance but are easily read. This applies to both regular view drawings and pictorial treatments.

Kinds of Shading. — Either outline shading or surface shading may be used as an aid in the representation of shapes, Plate 91, at M and N.

Outline Shading. — In order to produce a shadow, light is presumed to come from the upper left hand corner at an angle as illustrated at A, Plate 91. The shadow then falls to the right and bottom and might be represented as at B. On drawings it is reduced to the width of a heavy line, Plate 91 at C. When used such lines must, of course, be applied to all the views, top, front, and side. The light rays are considered separately for each view, as parallel and coming from the upper left hand corner at an angle of 45° . An inspection of the views at C, D, and M on Plate 91 will show where to place the shade lines. Use shade lines for lower and right hand edges of projecting parts. Use shade lines for upper and left hand edges of hollow or depressed parts.

Surface Shading. — Views with surface shading are shown on Plate 91. In general, only the curved and sloping surfaces are shaded. The position of the light rays, Plate 91 at E, illustrates the placing of the lines on a cylindrical surface. The heaviest of a series of parallel lines may be placed at the extreme right or bottom according to the position of the cylinder. A cone may be treated in the same way as shown at F. Note the shading on the hole at H.

Shading Isometric Drawings. — Plain isometric drawings are in pictorial form and are generally easy to read. Shading brings out the shape even more effectively and improves the appearance. Isometric drawings may be shaded on the edges or on the surfaces but the latter method gives the more satisfactory results. The light is assumed to come from above and the left.

Flat Surfaces. — Prisms, pyramids, and flat side objects are shaded with parallel lines. These can be vertical or parallel with the isometric angle, Plate 92 at A. Inclined surfaces receive more or less light than the regular isometric surfaces and accordingly are made darker or lighter. Horizontal surfaces are not shaded except when they represent the under side of an object as at C, Plate 92.

Curved Surfaces. — Cylinders and cones can be shaded as previously described for regular views, Plate 92 at D and E. Hollow cylinders have the shading on the opposite side as at D and I. Different methods are used for shading spheres but the one shown at F is a good one for either isometric or orthographic views.

An easy and practical method of representing where curved and flat surfaces join is given at G, Plate 92, and at C and D, Plate 97. The tangency of the surfaces can be made to show up well by using two or three heavy lines where the turn occurs. The method used at H, Plate 92, is more difficult and should not be attempted until after considerable experience.

The application of shading to isometric assembly drawings is illustrated on Plates 93 and 94. Note that this consists of shading the separate parts which make up the assembly.

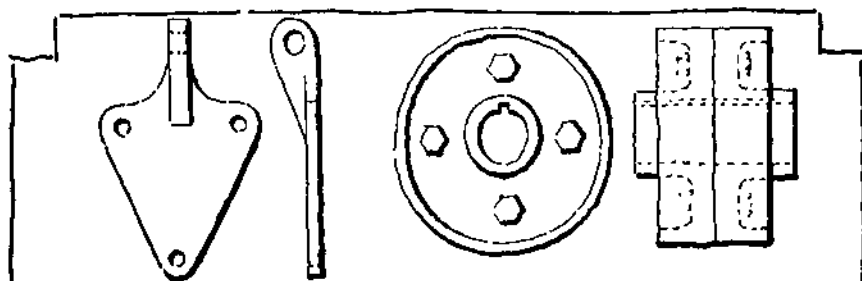
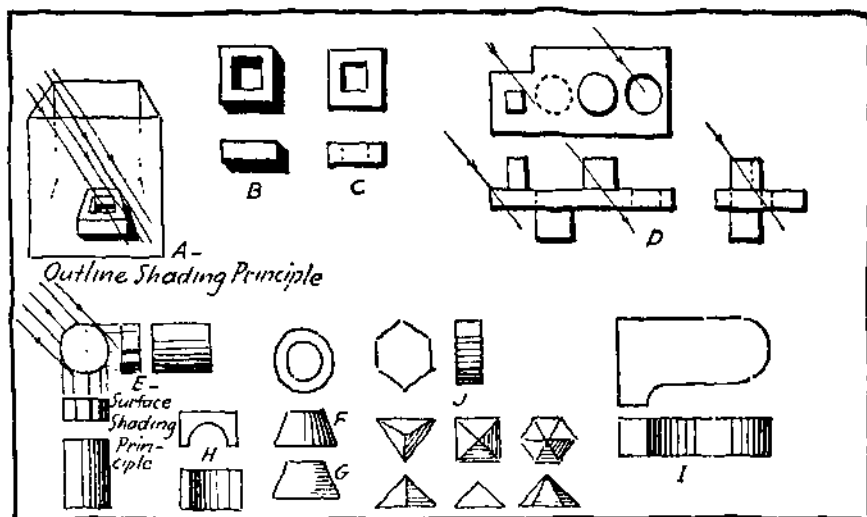

M - Examples of Outline Shading

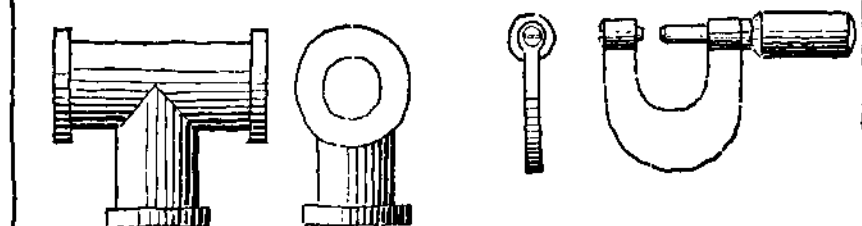

N - Examples of Surface Shading

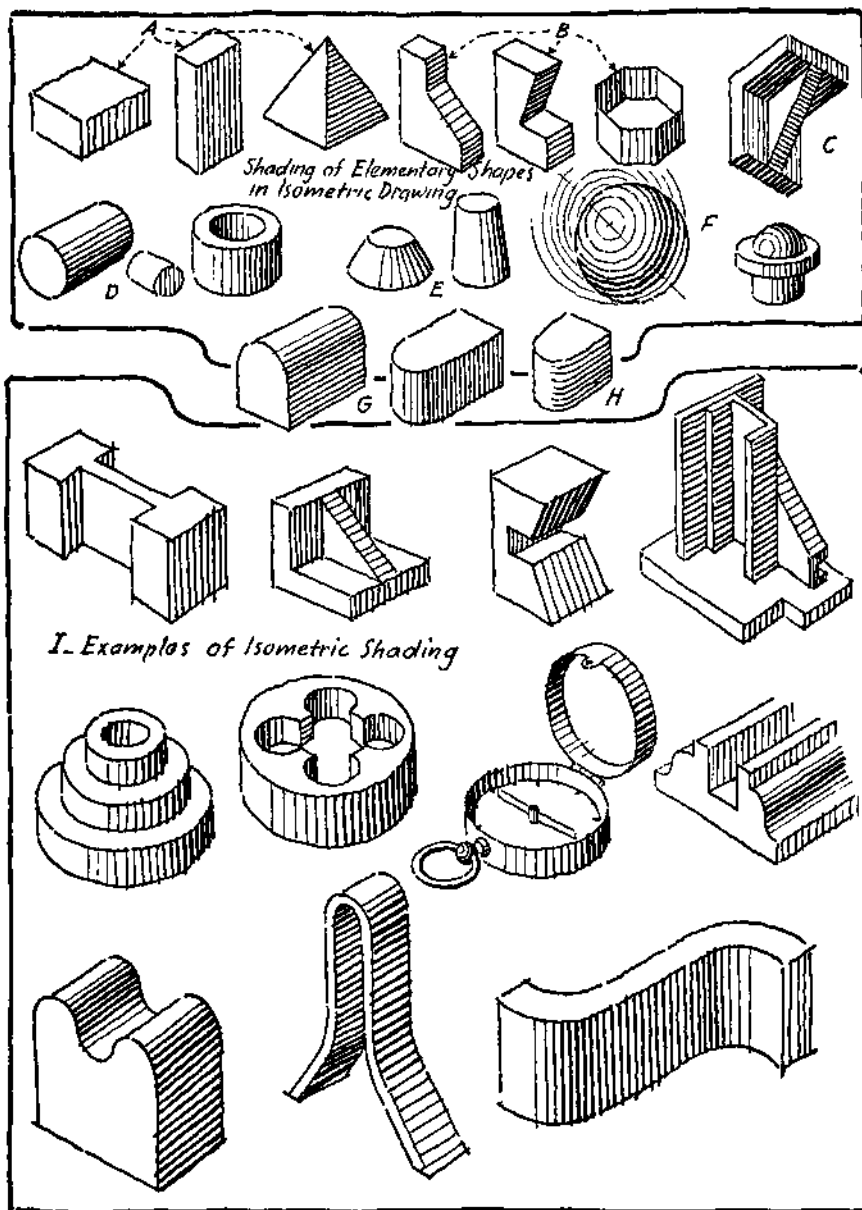

PLATE 92. Shading on Isometric Sketches.

This chapter is not intended to be a complete treatment of difficult double curved surfaces and irregular shapes but does present sufficient methods and examples for the average draftsman's use. Practice will develop skill. If not well done it is better to omit shading altogether.

Optional Methods of Shading.— There are a number of methods of shading flat and curved surfaces on isometric drawings and sketches. One method which is effective and is much used is *Line shading* as shown on Plate 92 and explained in the articles on " Flat Surfaces " and " Curved Surfaces." *Tone shading*, as shown at A on Plate 98, shows an even tint or tone, shading from dark to lightest gray on curved surfaces. *Solid black shading*, as shown at B on Plate 98, can be most effectually used on small drawings consisting of flat and vertical surfaces. *Stump* or *finger shading* can give a smooth, almost photographic semblance to a sketch where an artistic finish is desirable. *Quick line shading*, as shown at C on Plate 98, is the professional sketcher's technique and when handled by an expert gives a freehand drawing that look of mastery which is recognized in superior craftsmanship. *Stipple* or *dot shading*, as shown at D on Plate 98, requires time and care but the effect produced makes it a natural treatment for castings, rough surfaces, etc.

In the fields of freehand drafting which have to do with production illustration and technical illustrations, there are considerable variations in shading methods. Regardless of the merit of the methods used in pictorial work (whether with shading at the left, on high points of an object, or finishing touches placed at random), it is always best to follow a definite rule. Remember that light is invariably assumed to come from above and the left. Then, generally speaking, hollow parts will shade at the top and left, solid parts at the right and bottom.

There are other ways to shade a drawing. Commercial artists use the airbrush, " scrape away " on scratchboard, lay Ben Day tints or other screen or mechanical methods of surface shading,

wash drawings with brush and pen and ink, etc. These several techniques are designed for other purposes and are not practical for freehand drafting.

Problems. — Practice in applying the principles of shading to a selection of the problems which follow will serve to develop skill and confidence.

In addition to the problems laid out below, many of the projection and isometric drawings throughout the book make suitable material for outline, surface and isometric shading.

Use one of the layouts of Plate 4.

PROBLEMS 1 to 3, PLATE 95. — Represent the objects by views as shown. Use outline shading.

PROBLEMS 4 and 5, PLATE 95. — Represent the objects by views as shown. Use surface shading.

PROBLEM 6, PLATE 96. — Use an entire sheet to practice the shading strokes at A, B, C, D, and E. Use a rather soft pencil.

PROBLEMS 7 to 10, PLATE 96. — Represent the objects by isometric views as shown. Use surface shading.

PROBLEM 11, PLATE 97. — Use an entire sheet for the practice exercises shown at A, B, C, and D.

PROBLEMS 12 to 15, PLATE 97. — Represent the objects by isometric views as shown. Use surface shading.

PLATE 98. — Optional shading methods.

PROBLEMS 16 to 20, PLATE 99. — These are problems for surface shading.

PROBLEMS 21 to 23, PLATE 100.— These are problems for surface shading.

PROBLEMS 24 to 32, PLATE 101.— These are problems for tone, solid black, quick line and stipple shading.

PROBLEM 33, PLATE 102. — This is a problem for tone shading.

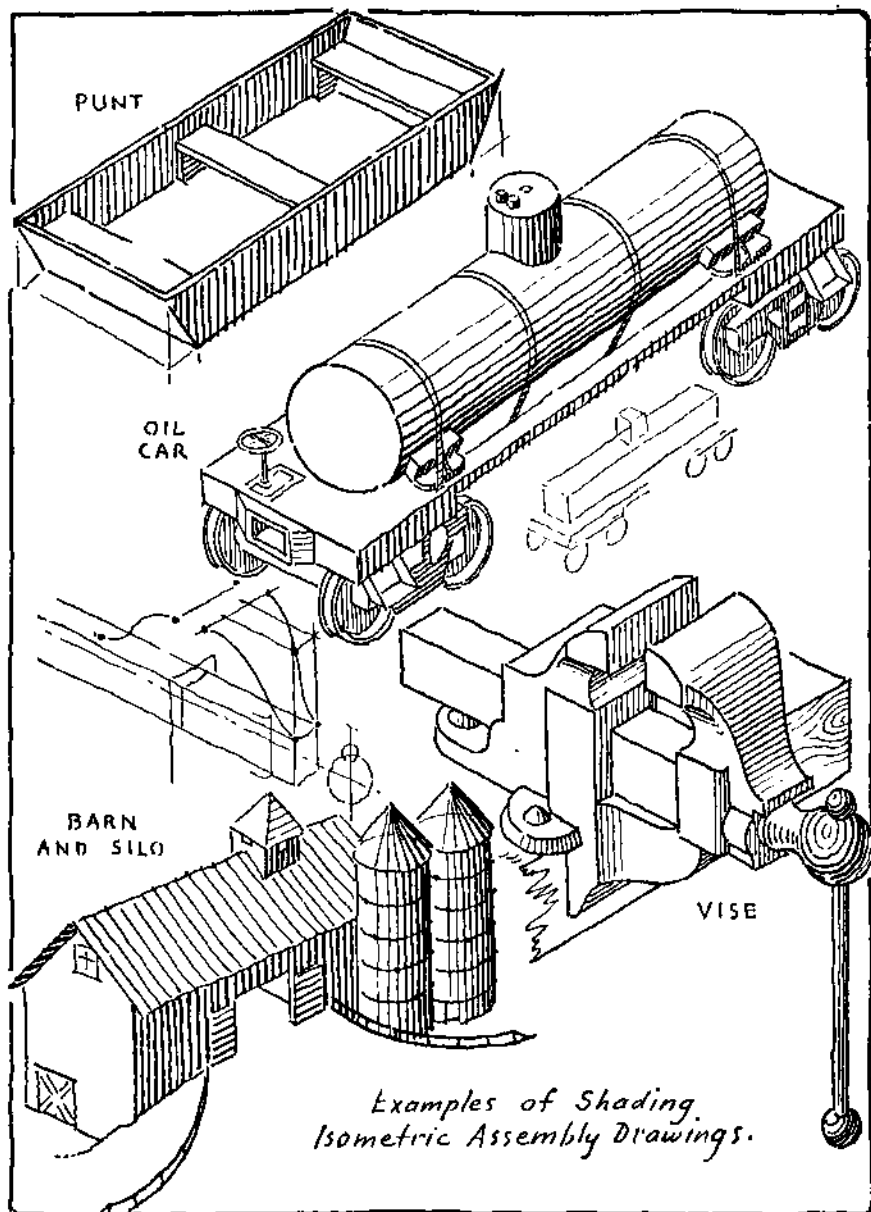

PLATE 93 Shading on Assembly Drawings.

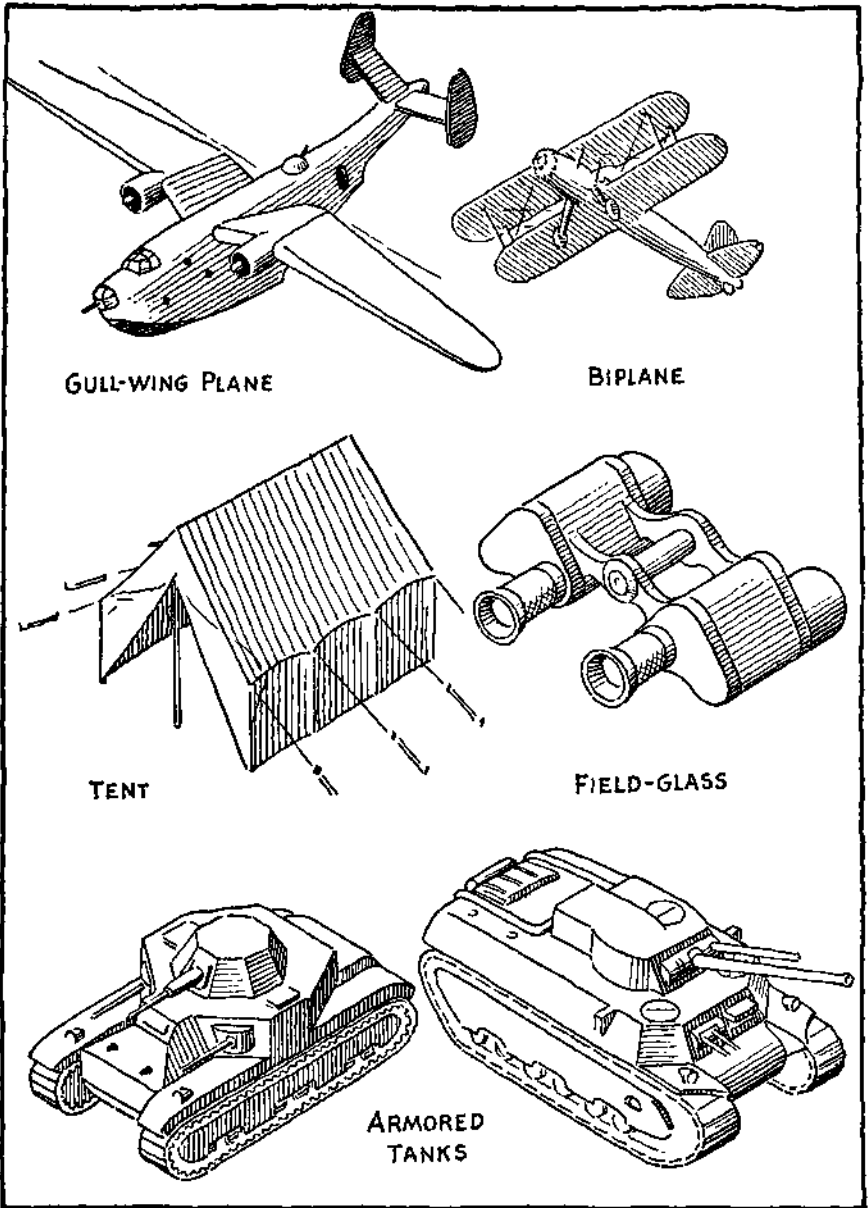

PLATE 94. Shading on Assembly Drawings.

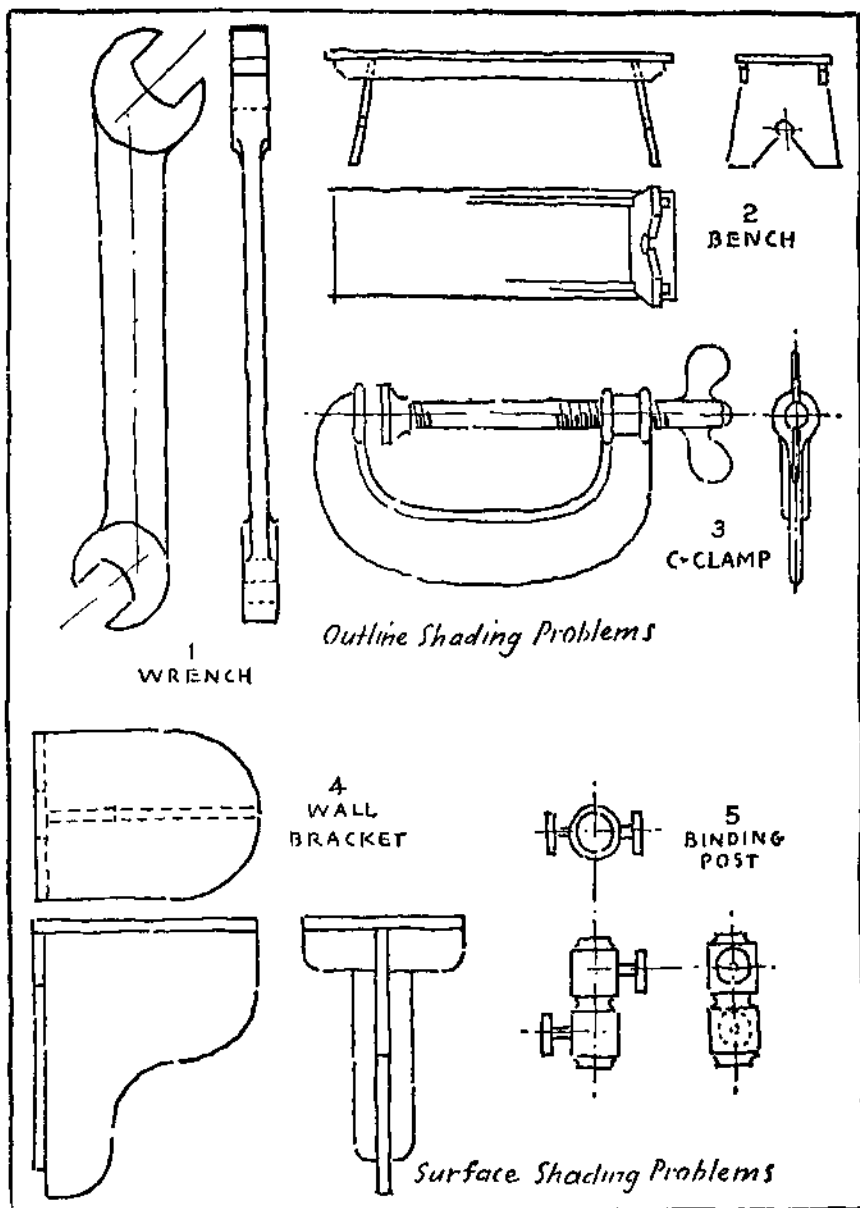
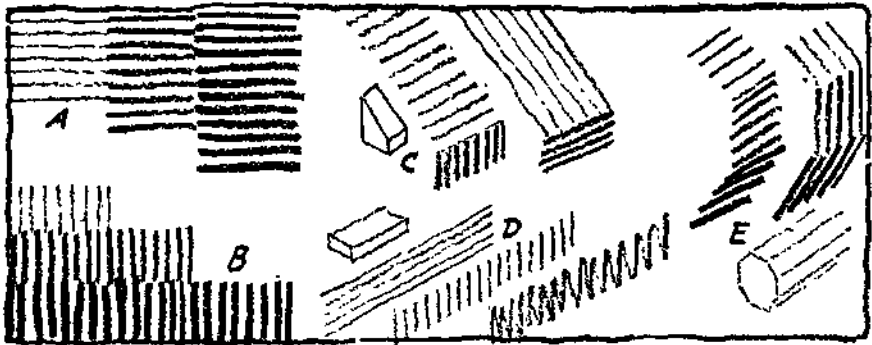
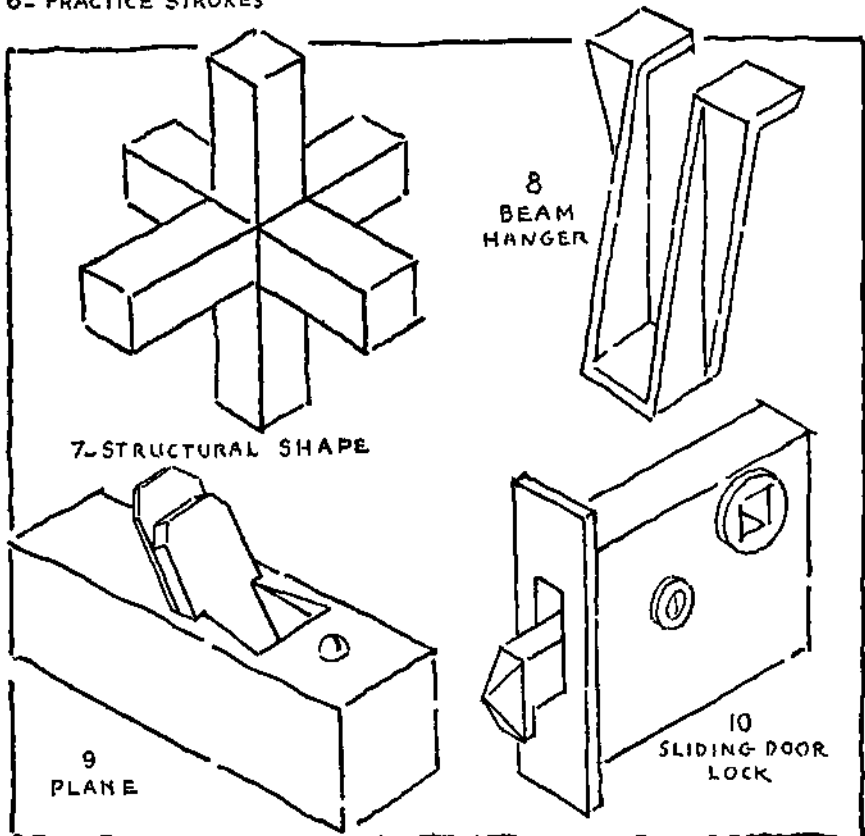

PLATE 95. Problems 1 to 5.



6- PRACTICE STROKES



7- STRUCTURAL SHAPE

8
BEAM
HANGER9
PLANE10
SLIDING-DOOR
LOCK

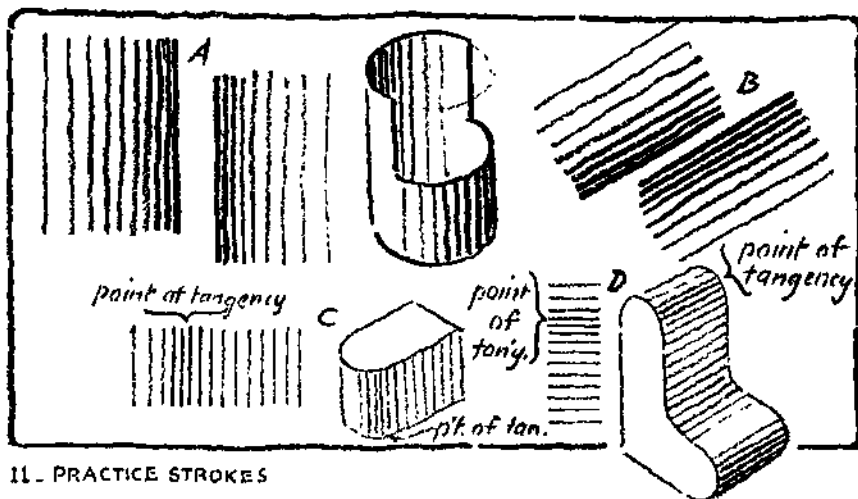

11. PRACTICE STROKES

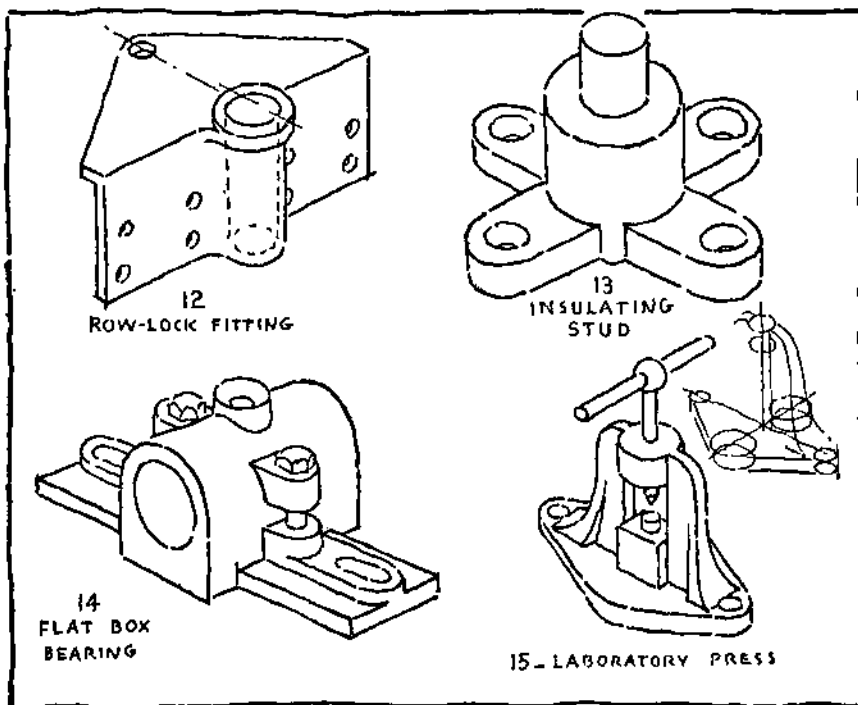

12
ROW-LOCK FITTING

13
INSULATING
STUD

14
FLAT BOX
BEARING

15. LABORATORY PRESS

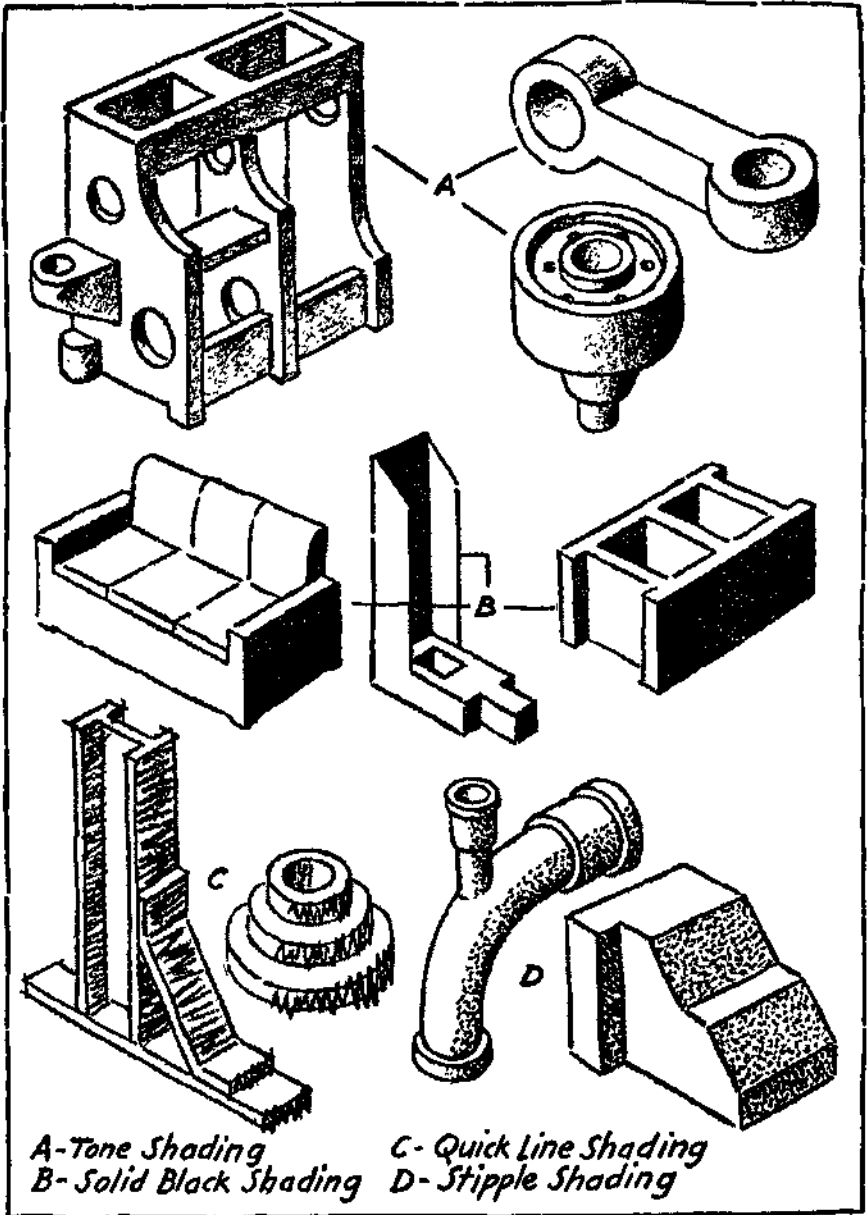

PLATE 98. Optional Sketching Methods.

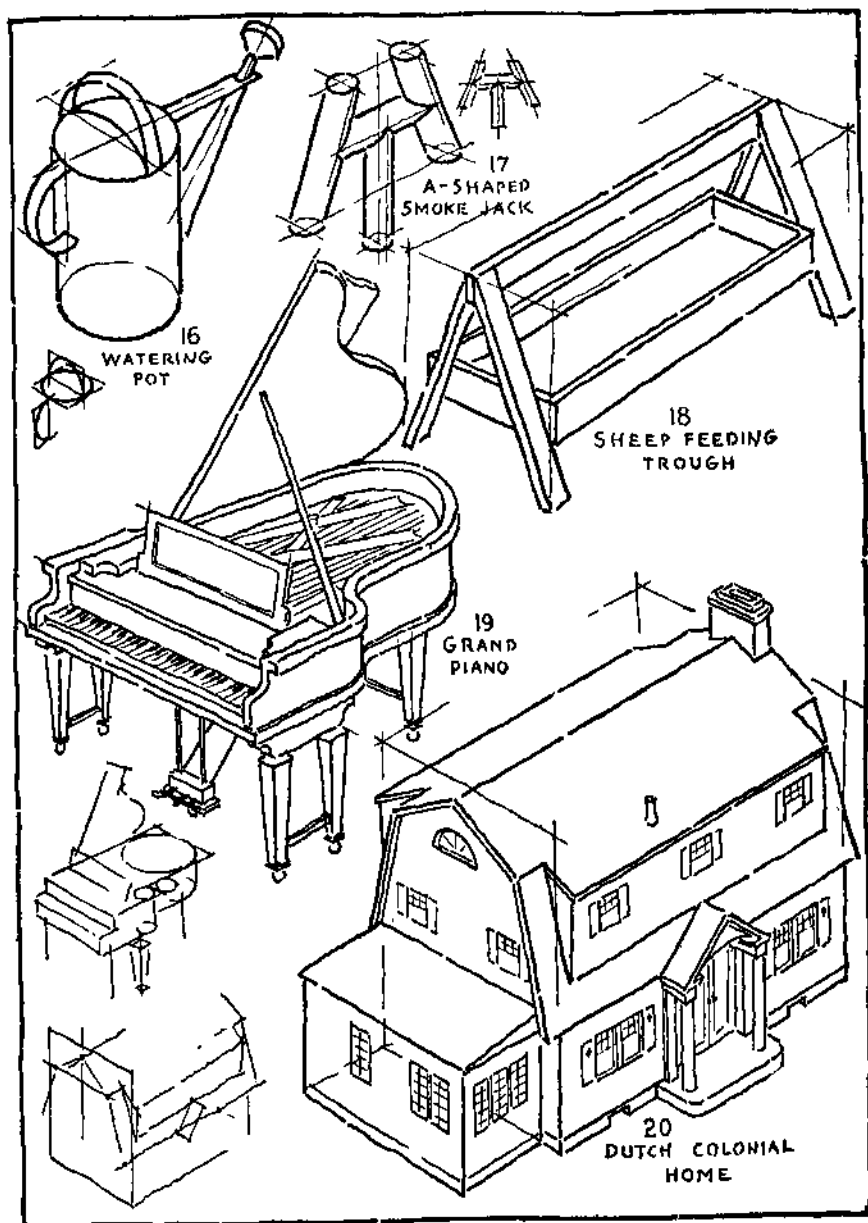
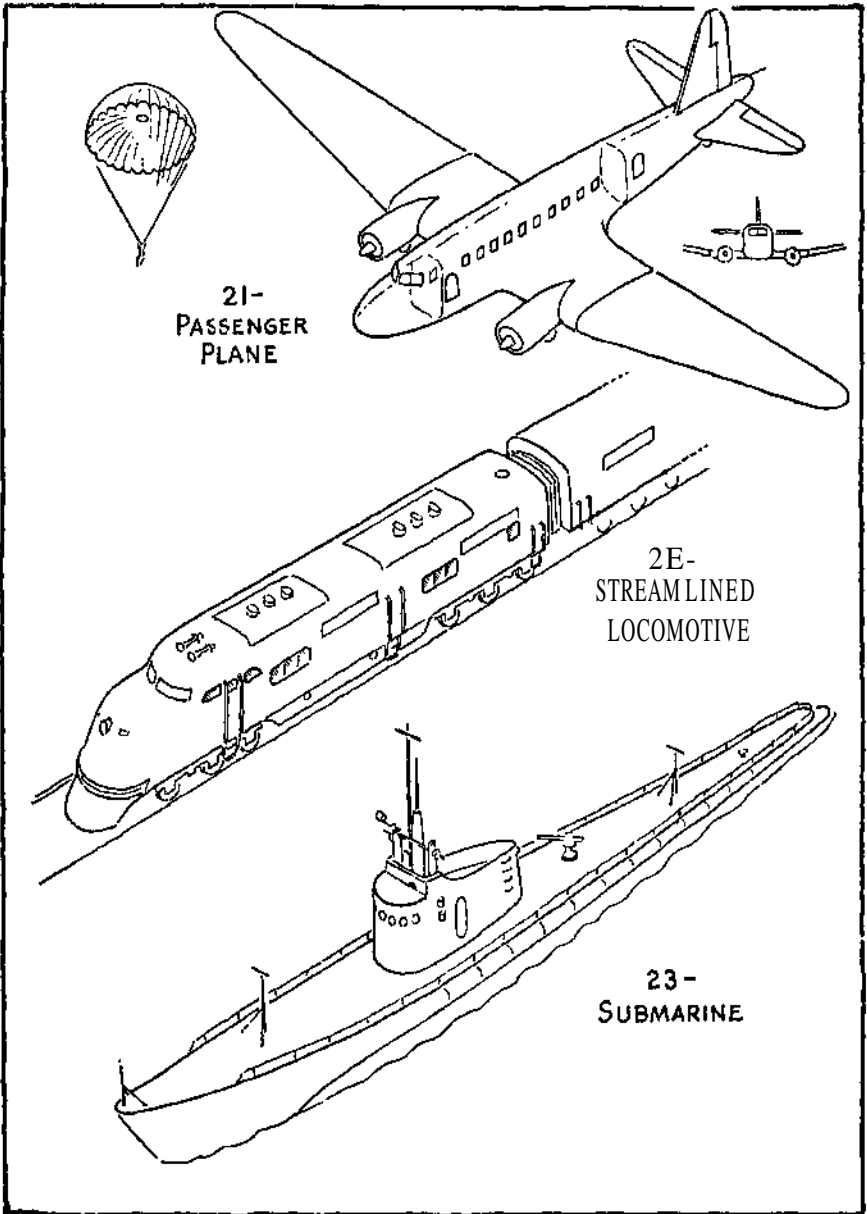

PLATE 99. Problems 16 to 20.



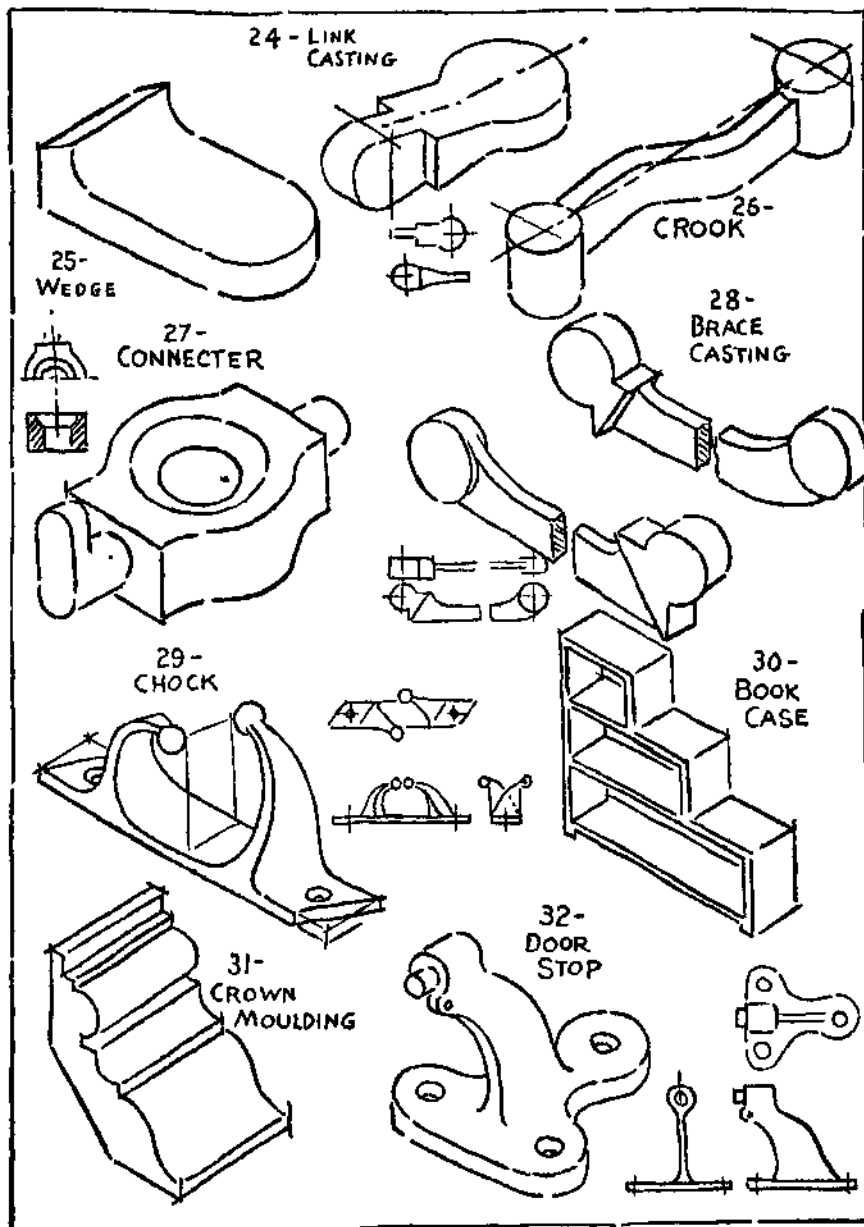
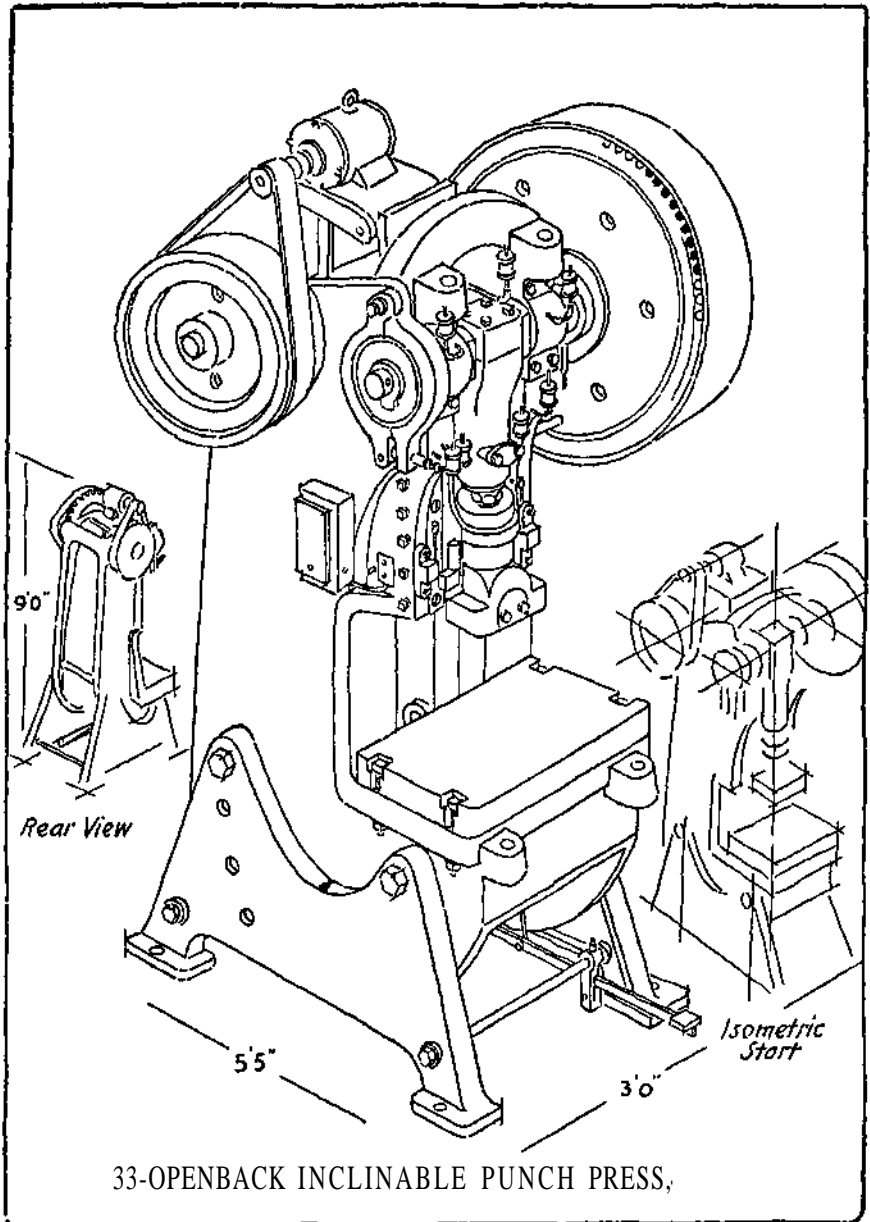

PLATE 101. Problems 24 to 32.



INDEX

Alphabets, 11

Architectural conventions, 90

Assemblies, 129

analysis of isometric, 131

diagram, 129, 135

exploded, 131

isometric, 130

outline, 129, 134

pictorial, 130

sectional, 129, 135

sheet metal, 130

ship, 130

sketching large, 131

special, 130

Assembly drawings, sketches, 129

views, 129

Auxiliary views, 52

Center lines, 87

Choice of letters, 15

Constructions, geometrical, 42, 43

Conventional methods, 87

representations, 91

Conventions, 87

architectural, 90

electrical, 88

hydrographic, 92

mechanical, 88

pipng, 88

riveting, 90

topographical, 92

Cutaway views, 147

Cutting plane, imaginary, 75

Description, methods of, 5

Design sketch, 6

Dimension lines, 89

Dimensioning, rules for, 89

Drafting, freehand, 6

mechanical, 5

Drawing, cabinet, 113

industrial, 52

isometric, 113

kinds of, 47

mechanical, 5

oblique, 113

orthographic, 6

perspective, 47, 113

Drawings and sketches, assembly, 129

Drawings, exploded, 147

pictorial technical, 147

scale, 91

shaded, 157

working, 49

Electrical conventions, 88

Elevation, 49

Exceptions to section rule, 77

Exercises in freehand sketching, 25

geometrical figures, 40

isometric ellipses, 41, 119

lettering, 15, 17

proportion, 53

Exploded assemblies, 131

drawings, 147

Extension lines, 89

Freehand drafting, 6

uses of, 6

Freehand lettering, 9

Freehand sketching, 21

exercises, 25

practice, 21

Full lines, 87

- Geometrical constructions, 42, 43
 Geometrical definitions, 35
 Geometry, 35
 figures in plane, 35, 36, 39
 figures in solid, 39, 40
 plane, 35
 practice exercises, 40
 solid, 35
 uses of, 35
- Half section, 77
 Hidden lines, 39, 87
 Hidden surfaces, representation of, 49
 Horizontal lines, 21
 sections, 77
 Hydrographic conventions, 92
- Illustration, production, 147
 Illustrator, technical, 147
 Imaginary cutting plane, 75
 Industrial drawing, 52
 Interior construction, representation of, 75
 Irregular curves, sketching, 102, 106, 125
- Isometric assemblies, 130
 analysis of, 131
 Isometric drawing, 113
 circles and curves, 117
 non-isometric lines, 115
 principles of, 115
 reversed axes, 117
 sections, 117
- Isometric drawings, shaded, 158
 Isometric ellipse construction, 41, 119
 Isometric shading, 158
 Isometrician, 148
- Kinds of drawing, 47
 cabinet, 113
 isometric, 113
 oblique, 113
 orthographic, 6
 perspective, 47, 113
- Kinds of lines, 87
 pictorial representation, 113
 sectional views, 77
 shading, 157
- Large assemblies, sketching, 131
 Laying out sheet, 15
 Left-hand workers, 23
 Lettering, 9
 exercises, 15, 17
 rule for spacing, 14
 spacing, 14
- Letters, capital, 11
 choice of, 15
 inclined, 11
 lower case, 11
 proportions of, 11
 single stroke, 9
 small, 11
 styles of, 9
 vertical, 11
- Line shading, 161
 Lines, kinds of, 87
 center, 87
 cutting plane, 89
 dimension, 89
 extension, 89
 full, 87
 hidden, 39, 87
 horizontal, 21
 non-isometric, 115
 quality of, 23
 shade, 157
 slant, 21
 vertical, 21
- Longitudinal sections, 77
- Material, sketching, 7
 Measurement by pencil, 131
 Mechanical conventions, 88
 Mechanical drafting, 5
 Mechanical drawing, 5
 Methods of description, 5
 Methods of representation, 47
- Non-isometric lines, 115
- Oblique drawing, 113
 Obtaining views from a model, 51
 Offsets, 117
 Optional methods of shading, 161
 Orthographic sketches, 6
 Outline shading, 157

- Paper, 7
 - cross-section, 8
 - in pad form, 7
 - isometric ruled, 8
 - letter size, 16
- Partial sections, 79
- Pencil measurement, 131
- Pencils, 7
- Phantom views, 147
- Pictorial assemblies, 130
- Pictorial representation, 113
 - kinds of, 113
 - uses of, 113
- Pictorial sketches, 6
- Pictorial technical drawings, 147
- Piping conventions, 88
- Planes of projection, 49
- Plan, 49
- Principle of sectional view, 75
- Principles of isometric drawing, 115
 - projection, 47
- Problems in assembly sketching, 132
 - auxiliary views, 52
 - conventional practice, 93, 95
 - exploded drawings, 148, 149
 - isometric sketching, 119
 - projection drawing, 53
 - sectional views, 81
 - shading, 162
- Production illustration, 147
 - uses of, 148
- Proportion, 51
 - exercises m, 53
- Proportioning and estimating measurements, 51
- Projection, planes of, 49
 - principles of, 47
- Projection box, 49
- Quality of lines, 23
- Quarter-circles, 23
- Quick line shading, 161
- Representation of interior construction, 75
 - hidden surfaces, 49
 - methods of, 47
 - pictorial, 113
- Representations, conventional, 91
- Riveting conventions, 90
- Rule for a good sketch, 51
- Rule for shading, 161
- Rule for spacing, 14
- Rules for dimensioning, 89
- Scale drawings, 91
- Sectional views, 75
 - imaginary cutting plane, 75
 - interior construction, 75
 - kinds of, 77
 - principle of, 75
 - treatment of shafts, bolts, etc., 77
- Sectional rule, exceptions to, 77
- Sections, 75
 - half, 77
 - horizontal, 77
 - partial, 79
 - solid black, 79
 - special, 79
 - thin, 79
 - transverse, 77
- Shaded drawings, uses of, 157
- Shaded sketches and drawings, 157
- Shading, curved surfaces, 158
 - flat surfaces, 158
 - isometric drawings, 158
 - kinds of, 157
 - line, 161
 - optional methods, 161
 - outline, 157
 - quick line, 161
 - solid black, 161
 - stipple, 161
 - stump, 161
 - surface, 158
 - tone, 161
- Shop sketch, 93
 - steps in making, 93
- Single stroke letter, 9
- Sketch, design, 6
 - shaded, 157
 - shop, 93
- Sketches, orthographic, 6
 - pictorial, 6
 - working, 91

- Sketching, circles, 23
 - freehand, 6
 - horizontal lines, 21
 - irregular curves, 102, 106, 125
 - large assemblies, 131
 - material, 7
 - quality of lines, 23
 - quarter-circles, 23
 - semi-circles, 23
 - slant lines, 21
 - tangents, 25
 - vertical lines, 21
- Sketching material, 7
 - paper, 7
 - pencils, 7
- Sketching practice, freehand, 21
- Sketching views from model, 54-58
- Solid black shading, 161
- Spacing letters, 14
- Special assemblies, 130
 - sections, 79
- Stipple shading, 161
- Stump shading, 161
- Styles of letters, 9
- Technical illustrator, 147
- Thin sections, 79
- Tone shading, 161
- Topographical conventions, 92
- Tracing, 6
- Uses of freehand drafting, 6
 - geometry, 35
 - pictorial representation, 113
 - production illustration, 148
 - shaded drawings, 157
- Vertical lines, 21
- Views, assembly, 129
 - auxiliary, 52
 - cutaway, 147
 - obtaining, from model, 51
 - phantom, 147
- Visualizer, 148
- Working drawings, 49
- Working sketches, 91

INDEX

INDEX

