

TIGHT BINDING BOOK

UNIVERSAL
LIBRARY

OU_158915

UNIVERSAL
LIBRARY

OSMANIA UNIVERSITY LIBRARY

Call No. 523-8/661A Accession No. 25722

Author Goldberg.

Title Atoms, Stars and Nebulae

This book should be returned on or before the date last marked below.

THE HARVARD BOOKS ON ASTRONOMY

Edited by

HARLOW SHAPLEY AND BART J. BOK

ATOMS, STARS,
AND
NEBULAE

BY

LEO GOLDBERG

(Now of the McMath-Hulbert Observatory
of the University of Michigan)

AND

LAWRENCE H. ALLER

(Now of Indiana University)

THE BLAKISTON COMPANY

Philadelphia

Toronto

COPYRIGHT, 1943, BY THE BLAKISTON COMPANY

Reprinted, February, 1944

Reprinted, April, 1945

Reprinted with additions, September, 1946

This book is fully protected by copyright, and no part of it, with the exception of short quotations for review, may be reproduced without the written consent of the publisher

PRINTED IN THE UNITED STATES OF AMERICA
BY HARRIS AND PARTRIDGE, INC., PHILADELPHIA, PA.

CONTENTS

	1	
Introducing the Stars and Nebulae		1
	2	
Stellar Rainbows.		19
	3	
Atoms and Molecules, Stellar Building Blocks.		40
	4	
The Climate in a Stellar Atmosphere		62
	5	
Dwarfs, Giants, and Supergiants		78
	6	
Analyzing the Stars.		100
	7	
Pulsating Stars.		128
	8	
Exploding Stars		152
	9	
The Planetary Nebulae		173
	10	
Between the Stars.		197
	11	
Stars with Extended Atmospheres.		222
	12	
What Makes the Stars Shine?		255
Appendix		283

1

INTRODUCING THE STARS AND NEBULAE

*T*O THE MEN OF ANCIENT TIMES THE UNIVERSE WAS A SECURE and stable world, constructed, so it seemed, for the sole convenience of the human race. That man's abode, the earth, should occupy the dominant central position was hardly to be doubted, while the sun's justification for existence was to provide us with light and with life-sustaining energy. The gleaming stars, imbedded in the revolving celestial sphere, were looked upon as part of a cosmic mural designed to beautify the night.

It was only natural, too, that the details of the stellar scenery should have been identified with the mystical heroes and objects of mythology, identifications that remain in current use as the names of star groups, or constellations. Thus the unexcelled constellation of the winter sky is Orion, the mighty hunter, whose club is upraised against the charging bull Taurus. (Figure 1.) Behind Orion his two dogs pursue Lepus, the fleeing hare. Marking the eye of the greater dog is sparkling Sirius, the dog star. To the ancient Egyptians Sirius was the popular Nile star, whose

surroundings. With the passage of time his approach to the heavens has become increasingly skeptical, and stellar mythology has given way to a more objective study of the stars. The astronomical explorer has found in the universe a happy hunting ground for exciting discoveries, and, to add spice to the chase, each great addition to our knowledge has brought forth scores of fresh, unsolved problems. The process seems unending, and mysteries will probably never be lacking as long as there are men to ponder them.

We hope in this book to take the reader with us on a journey of astronomical exploration so that he himself will sample a little of the thrill of discovery. During the course of our journey we shall probe into the seething atmospheres of the stars and even dig into the interiors themselves. We shall encounter all sorts of curious objects: single stars, double stars, and multiple stars, dwarf stars and giant stars, cool stars and hot stars, stars that pulsate, and occasionally some whose surface layers are suddenly wrenched away in cataclysmic stellar explosions.

Our course among the stars has already been charted, for, in its broad outlines at least, the geography of the universe, or rather the portion of it that we have been able to observe, seems fairly well established. Far from being the hub of the universe, the earth is but one of a family of planets, comets, and meteoric particles that revolve periodically about the sun. The sun in turn is one member of a vast aggregation of stars, perhaps a hundred billion, which are roughly grouped together in the form of a thin lens (see Figure 2). This system of stars, within which are contained all stars visible to the naked eye as well as millions that are too faint to appear visually, is known as the *Galaxy*, or *Milky Way*. The sun's location in the Galaxy is at a point approximately one half to two-thirds of the way from the center to one edge. The observable universe

is known to consist of several hundred million widely separated galaxies, or island universes, most of them not unlike our own Galaxy. There is no indication that we have approached the boundaries of the system, if any exist. In our tour of exploration, we shall remain largely within the confines of our own Galaxy, but we have reason to believe that our sample is more or less typical of the universe as a whole.

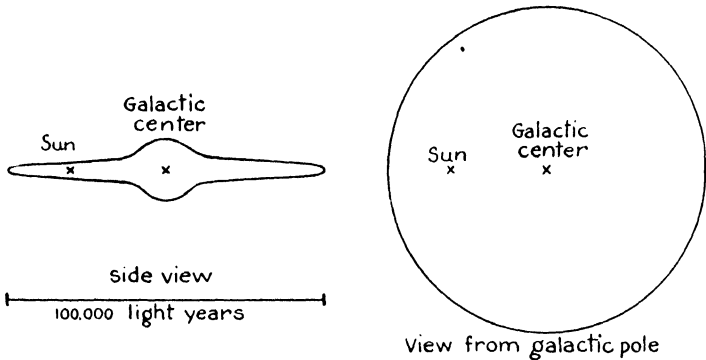

Fig. 2.—Schematic outline of the Milky Way system.

(Bok and Bok.)

The voyages between stars are likely to be smoky, for interstellar space is strewn with great clouds of dust and gas that dim and redden the light from the stars beyond. Like powerful searchlights, bright stars illuminate many of these clouds, revealing them to the astronomical explorer as bright nebulae. We shall see that the interstellar matter is spread so thinly that, by comparison, the amount of gas present in the best vacuum attainable in the terrestrial laboratory seems enormous. Yet, despite its extreme tenuity, enough dust and gas is spread over the huge galactic volume to equal approximately the combined masses of all the stars.

One of the features of our tour of discovery is that it can be made without the usual perils of exploration. In fact, due to the magical powers of light rays, we are able to explore the far corners of the universe without leaving the comfort and security of the earth. Thus the astronomer of a century ago mapped the positions of stars upon the sky and designated their locations much as a geographer maps the earth from accurate measures of latitude and longitude at various points upon the earth's surface. The positions of the stars are found from the directions of the light rays they emit. But direction is only one characteristic of light rays; starlight also carries a message of the physical natures of the stars—their masses, brightnesses, chemical compositions, and even the nature of their internal structures. It is only recently that we have learned to read these hieroglyphic messages from the stars. Modern physics, which tells how atoms are built and how they radiate light, has made this analysis possible. The story of the interpretation of stars and nebulae, so highly dependent on the findings of modern physics, is the one that we shall emphasize in this book.

STELLAR DISTANCES AND BRIGHTNESSES

Four obvious questions will occur to anyone interested in probing into the physical nature of the stars, namely, how distant are the stars, how bright, how big, and how heavy. To answer these questions we must find measuring rods and scales that can be applied over large distances. An astronomer uses the same principle to measure the distance of a star as a surveyor uses to measure the distance across a lake. Figure 3 illustrates the surveyor's problem, Figure 4 the astronomer's. The former measures the line AB , and the angles ABC and CAB . The determination of two angles and an included side serves to fix the triangle

ABC , and the side AC or BC may be computed. The astronomer uses as his baseline AB , the diameter of the earth's orbit. When the earth is at A the star lies in the direction AC ; six months later the earth is at B and the direction of the star is now BC . One half of the angle of displacement, i.e. the angle BCD or ACD , is known as the *parallax* of the star. The amount of the shift will depend on the proximity of the star, the more distant ones being least affected.*

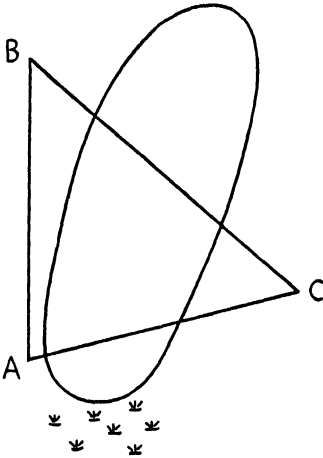

Fig. 3.—The measurement of the distance across a lake by triangulation.

The unit of stellar parallax is the second of arc, or $\frac{1}{3600}$ of one degree, which is roughly the angle subtended by a penny at a distance of two and a half miles. So small an angle cannot be distinguished with the unaided eye, but

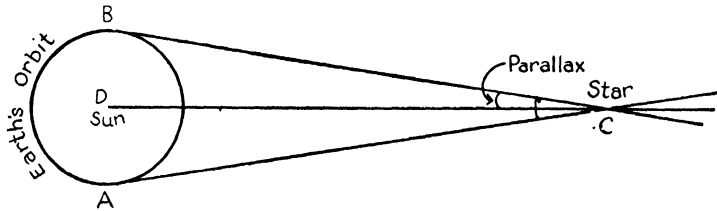

Fig. 4.—The parallactic shift of a star.

modern telescopes enable parallaxes of one hundredth of a second of arc to be measured with fair accuracy. The

* For further details, see Chapter 2, p. 31 of *The Milky Way*, The Harvard Books on Astronomy.

parallax of Alpha Centauri,* the nearest star, is $0''.76$, corresponding to a distance of about twenty-five million million miles. To express such distances as this in miles is more awkward than giving the distance from New York to Manila in millimeters; hence stellar distances are often expressed in *light years*. One light year, the distance traversed in one year by a ray of light travelling 186,000 miles per second, is nearly six million million miles. The nearest star is 4.28 light years away; Sirius, the brightest star in the sky, is at a distance of 8.6 light years, and our entire system of stars, the Milky Way, probably measures one hundred thousand light years across. On such a scale our solar system seems tiny, indeed. For a light ray could circle the earth in a seventh of a second and journey to the sun in less than nine minutes. Also, if we represent the distance from the earth to the sun by one inch, a light year corresponds very nearly to one mile. †

* The brighter stars within each constellation are labelled with the letters of the Greek alphabet in order of decreasing brightness. Thus the brightest star is alpha, the next brightest beta, etc. Fainter stars are designated by numbers in catalogues. Two well known catalogues are the Bonner Durchmusterung (B.D.) and the Henry Draper Catalogue (H.D.). The B.D. stars are numbered according to right ascension in one-degree zones of declination. Thus B.D. $+30^{\circ}$ 3639 means the 3639th star in the zone $+30^{\circ}$ to $+31^{\circ}$. In the Henry Draper Catalogue the stars are listed according to their right ascensions irrespective of declination rather than by zones as in the B.D.

† Two other units of distance, the *astronomical unit* and the *parsec*, are also useful in astronomy. For expressing lengths intermediate between the mile and the light year, the radius of the earth's orbit, the astronomical unit (abbreviated to A.U.), is commonly used. This latter quantity should not be confused with the angstrom unit (abbreviated A) used to express the wave length of light. The parallax of a star 206,265 A.U. away is one second of arc; the corresponding distance is called one parsec, which is equivalent to 3.26 light years. Since parallax is inversely proportional to distance, the distance in parsecs is simply the

The surveyor's method of measuring parallax is inadequate for more than the very nearest stars; a star at a distance of 326 light years shows a parallax of $0''.01$, and smaller angles cannot be measured with any precision. Fortunately, astronomers have devised ways of estimating the distances of the remoter stars; some of these methods we shall describe later.

Once the distance of a star has been found, we may, knowing its apparent brightness, establish its true brightness from the fact that the brightness of a point source of light diminishes as the square of its distance. If the sun, for example, were removed to twice its present distance, it would appear only one quarter as bright. The current practice of expressing the apparent brightness of a star as seen in the sky in terms of *magnitudes* was initiated two thousand years ago, when ancient astronomers graded the stars from the first to the sixth magnitude, the latter being just barely visible to the naked eye. For the past century, the scale of magnitudes has been so adjusted that a star of the first magnitude is exactly one hundred times as bright as one of the 6th magnitude. A first magnitude star is thus 2.512 times as bright as a second magnitude star, which in turn is 2.512 times as bright as a third magnitude star, etc. Also, the original scale of six magnitudes has been extended to include the very faint as well as the very bright stars. The brighter stars in the sky, like Aldebaran and Altair, are of the first magnitude; the magnitude of Capella is 0.2, that of Sirius is -1.6 , while on the other end of the scale stars of the 21st magnitude have been photographed with the 100-inch reflector at Mt. Wilson.

reciprocal of the parallax in seconds of arc. Thus a star ten parsecs or 32.6 light years away has a parallax of $0''.1$, a star 100 parsecs away has a parallax of $0''.01$, etc.

If all stars were equally distant from our sun, their apparent magnitudes would represent their true relative brightnesses. In practice, the intrinsic luminosity of a star is defined by its so-called *absolute magnitude*, which is the apparent magnitude it would have at a standard distance of ten parsecs or 32.6 light years. (See Appendix D.) The absolute magnitude of the sun is $+4.73$ (according to Kuiper), which tells us that at a distance of ten parsecs it would be just nicely visible on a clear moonless night. Arcturus would appear at about its present brightness since its distance is 33 light years. Sirius would be a fourteenth its present brightness and no longer conspicuous, but the southern star, Rigel, which is 20,000 times brighter than the sun, would outshine any object in our present night sky save the moon.

The eye, photographic plate, and photoelectric cell are sensitive to certain colors and not to others. For example, a red star may appear bright to the eye, yet faint to the photographic plate. If we wish to express the brightness of a star, taking into account all the radiation it emits: infra-red, red, green, blue, violet and ultra-violet (Chapter 2) we use the *bolometric* magnitude which includes radiation not perceptible to the eye as well as ordinary light. The bolometric absolute magnitude of the sun is $+4.62$; its so-called *photographic*, or blue, absolute magnitude is $+5.4$.

WEIGHING THE STARS

The motion of the earth about the sun makes possible the determination of stellar distances. Curiously enough, the circling of one star about another permits the determination of stellar masses. Like all planets, and stars too for that matter, the earth is imbued with a wanderlust. Were the restraining influence of the sun's gravitational attraction

suddenly to be removed, the earth would fly off in a straight line and eventually lose itself in interstellar space. Just as the earth is kept in its path by the gravitational attraction of the sun, so also are a large number of stars denied a care-free existence by the gravitational attractions of companion stars. Stars so inhibited pursue circular, or elliptical orbits about one another. The more massive the two stars, the faster will they move about one another, which we may see from a simple analogy.

Suppose we were in a space-ship in interstellar space, where there was no gravitational attraction, so that we floated freely about, and suppose further that it was necessary to measure the weight of a small solid object. Since gravity would not exist inside the space ship, we could not just put the object in a scales and weigh it; some other technique must be used. If a spring scales were available, the unknown mass could be found by attaching the object to the scales and swinging them both in a circle at the end of a string. The spring scales would measure the tension in the string, which would depend on the speed of revolution and the mass of the object. The tension would be greater, the greater the mass or the greater the speed of revolution. From the measured tension and the speed of whirling, we could find the mass of the object.

By an analogous procedure the astronomer weighs the stars. The rate of motion of two stars in a double star system about one another depends on the gravitational force between them. This attractive force, analogous to the tension in the string, is proportional to the masses of the stars (and also to the inverse square of the distance between them), according to Newton's Law of Gravitation. By observing the time required for the two stars to circle each other and by measuring the distance between them, we find the restraining force and hence the masses.

Double star systems are common among the stars. In fact, groups have been found in which 3, 4, 5, and even 6 stars revolve about one another. Some of these binary systems merit a brief description.

Alpha Centauri consists of two stars that revolve about one another in eighty years in rather eccentric orbits, so that at times they approach as near as 11 astronomical units (a little greater than the distance of Saturn from the sun) and sometimes they recede to 35 astronomical units (nearly the distance of Pluto from the sun). The brighter component is almost a duplicate of the sun, save that it is perhaps a little heavier, a little brighter, and perhaps a little hotter. The fainter component is cooler and less massive. In 1915, Innes discovered a faint red star two degrees away which shared the same motion through space as Alpha Centauri but was 15,000 times fainter than the sun. It is at least ten or twelve thousand astronomical units from the brighter pair and must take about a million years to complete its orbit.

Of multiple stars we may mention Castor, discovered as a double by Bradley and Pound in 1719 and ξ Ursae Majoris discovered by Sir William Herschel in 1780. In the telescope these systems appear as double stars but spectroscopic methods (see Chapter 2) have shown that we deal in each case with quadruple and not double stars.*

ξ Ursae Majoris has been studied by Wright, van den Bos, and Berman. The brighter component is composed of two stars which move about one another in 1.83 years, but the two stars of the fainter component swing around each other in four days. Finally the two pairs move about their common center of gravity in sixty years! Berman finds the

* Herschel discussed these binaries in his Royal Society papers in 1803 and 1804 in which he gave observational as well as theoretical reasons for believing double stars to be physical systems.

total mass of the system to be 2.27 times that of the sun. The two stars of the brighter component have 0.93 and 0.35 times the mass of the sun, while the two stars of the fainter component together weigh about as much as the sun.

As seen in a telescope, Castor is a double star, whose components, separated by a distance of about 80 astronomical units, move about one another in a period of 340 years, according to Luyten. Belopolsky, in 1896, found spectroscopically that the fainter of the two stars was itself a double with a period of about 3 days. Curtis in 1904 found that the brighter component was also a double with a period of nine days. An even more interesting result is that more than a minute of arc away from Castor is a faint star, associated physically with the brighter pair, which van Ghent and also Adams and Joy found to be a binary. Castor, therefore, is a sextuple star whose components appear in pairs.

Although more than 17,000 double stars are listed in Aitken's catalogue, reliable orbits are known for relatively few of them. A hundred years from now our knowledge of binary orbits, and stellar masses, should have improved greatly.*

The multiple systems are composed of all kinds of stars, large and small, cool and hot; consequently we are able to determine masses for most varieties of stars. When the weighing operation is completed, we find that the most massive stars are about a hundred times heavier than the sun; the lightest stars have probably between one fifth and one tenth the solar mass, with the majority weighing a bit less than the sun.

* Fortunately, as Russell and Hertzsprung independently showed, it is possible to get good average values of the masses of stars whose parallaxes are known, even if we observe the motion of a star over only a part of its orbit.

In many instances a star trapped in a double-star system is forced to reveal not only its weight but also its size. Double-star components are frequently so close together that even the most powerful telescope fails to reveal them separately. If, however, the plane of the orbit is so tilted as to appear edgewise in the sky, the passage of one star in front of the other will produce a periodic eclipse, not unlike an eclipse of the sun by the moon. Such double stars are known as *eclipsing stars*. In general, each star masks the other once during a revolution, thus producing two eclipses per cycle. If the two stars are of equal size and brightness, the amount of light received on the earth will be cut in half twice during a revolution. Usually, however, the components of eclipsing stars tend to be of unequal brightness and size; the pairing of a large, faint star with one that is small and bright is a frequent occurrence. Such a pair of stars is shown diagrammatically in Figure 5. The passage of the bright star across the faint one produces a partial eclipse of the latter and a resultant dimming of the total light. Half a revolution later, the relative positions of the stars are reversed, and since the bright star is now obscured, the loss of light is much greater. If the observed brightness of the eclipsing star is plotted against the time, we find a periodic variation in the light as shown in Figure 6. When the bright star is at positions *A* and *C* in the orbit, the light is undimmed. At point *D*, the brighter of the two stars is obscured and the star is said to be at *primary minimum*. At point *B*, the faint star is partially obscured, only a small fraction of the light is lost, and the star is said to be at *secondary minimum*. It is clear that the duration of each eclipse, which may be learned from the light curve, depends both upon the diameters of the stars and upon the speed of revolution. Since, as we shall see in the next chapter, we may frequently

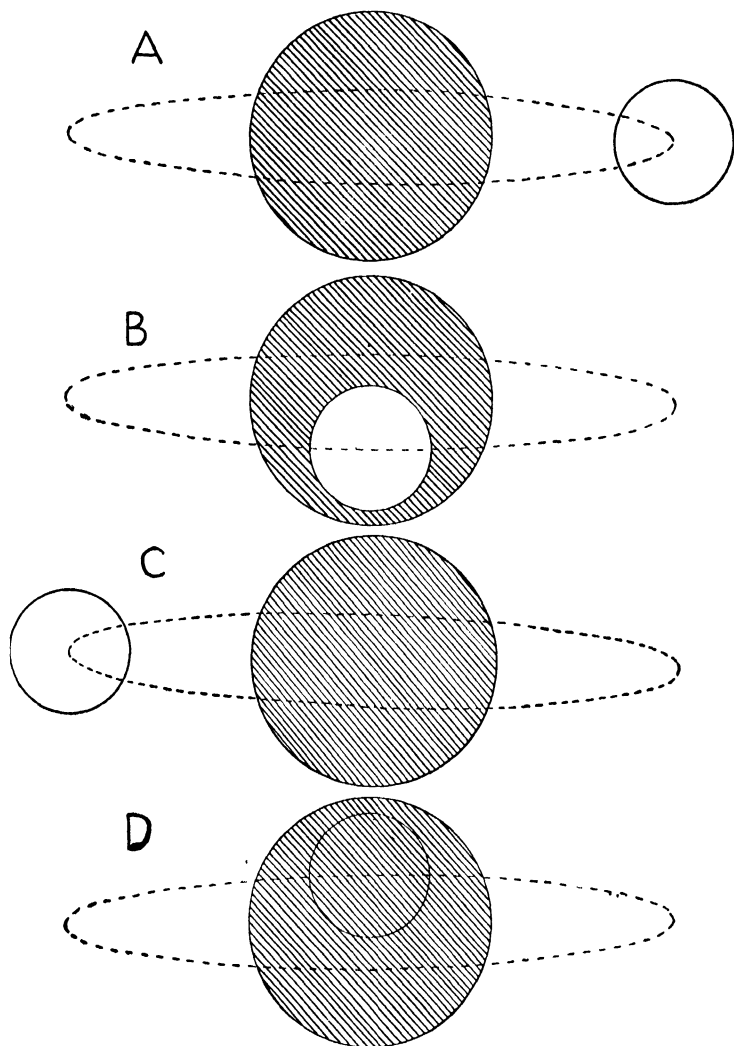

Fig. 5.—Schematic diagram showing the relative positions of the stars in an eclipsing system.

With respect to an observer as they move around in their orbits. In this case a small bright star is eclipsed by a large faint one.

determine the latter by means of the spectroscope, we can find the stellar diameters.

We can do even more. If we know the orbital speeds of the stars as well as the time it takes for them to move around one another, we may determine their masses, and consequently their densities. In some cases where the light curve has been followed over several decades we can obtain further accurate information about the rate at which the density

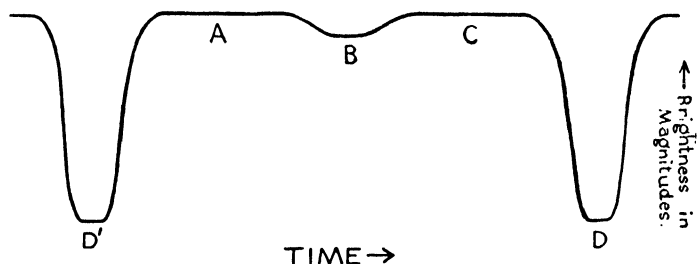

Fig. 6.—The light curve of the eclipsing binary represented in figure 5.

The letters *A*, *B*, *C*, and *D* refer to the various positions of the stars in their orbits (of Figure 6). Magnitude is plotted against time. The distance *D'D* represents the period.

increases towards the center in the heavier star of the eclipsing system.*

In Table 4 we list the sizes, masses, and densities of some well-known eclipsing stars for which reliable data have been obtained. The faintest eclipsing system is the companion of Castor. Among the brightest and most massive systems are *V* 380 Cygni, *VV* Cephei, and Beta Lyrae.

Probably the best known of eclipsing systems is Algol, the second brightest star in the constellation of Perseus,

* See Campbell and Jacchia, the "Story of Variable Stars" p. 188. In this way it has been found that the stars are not homogeneous but show considerable concentration of mass towards the center.

which at intervals of 2.87 days suddenly diminishes to about one third its usual brightness. The diameter of the brighter component is about 2,700,000 miles, or three times the diameter of the sun, whereas the larger but much fainter component measures 3,200,000 miles across.

THE MASS-LUMINOSITY LAW

The scientist is constantly on the alert to find correlations between independently observed quantities, such as the masses, luminosities, and diameters of the stars. To illustrate the meaning of a correlation, suppose we were to make a study of the sizes of boys of all ages ranging from several months to twenty years. We would find, on the average, that the tallest boys were also the oldest, although an occasional lad would be smaller even though older than another. We say that the two observed quantities, age and height, are correlated. We know, for example, that the pressure of the earth's atmosphere diminishes in a regular fashion with increasing altitude. The two observed quantities, altitude and pressure, are said to be inversely correlated. The advantage of such correlations is that we need only to measure one quantity in order to get an idea of the other. Similarly, one of the most important outcomes of the study of double stars has been the discovery that stellar mass and luminosity are correlated, in the sense that the heaviest stars are also the brightest. If we plot the masses of the stars as determined from double stars against their luminosities, we find that the points follow the curve shown in Figure 7. Once the relation between mass and luminosity has been established, we may use it to estimate, with some confidence, the masses of single stars.

When we combine the observed data on the masses, luminosities, and dimensions of the stars, we find that most of the stars in a given volume of space near the sun are not

only fainter than the sun; they are also redder, smaller, denser and less massive. A relatively smaller number are both hotter and larger. In Chapter 5 we shall see that the race of stars to which the sun belongs forms a continuous sequence, stretching from very blue and bright objects at

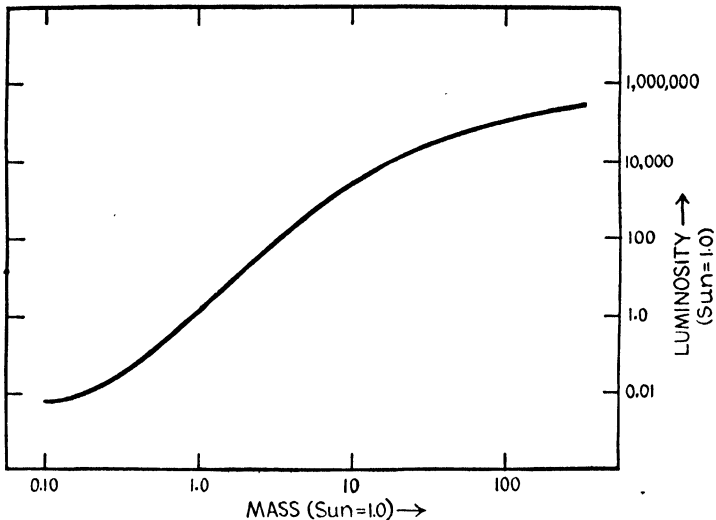

Fig. 7.—The relation between the masses and luminosities of the stars.

Note that in order to exhibit a great range of masses and luminosities on one diagram we have resorted to a non-linear (logarithmic) scale. The mass-luminosity law was discovered by Sir Arthur Eddington in 1924. (After Kuiper.)

one end to red and faint stars at the other. In a second group we find yellow, orange, and red stars which are twenty or thirty times larger than the sun, the so-called “giants.” Still other stars, the “supergiants” are frequently so huge that if one were to be placed at the center of the solar system, the earth would be swallowed up millions of miles beneath its surface. The supergiants are sometimes thousands of times more luminous than the sun. Finally we should

mention the "white dwarfs," which are often no larger than the earth, although weighing as much as the sun. A cupful of material scooped from the interior of a white dwarf would probably weigh tons.

OTHER "SOLAR SYSTEMS"?

An important recent discovery has been the detection of planet-like companions to certain well-known visual double stars. K. A. Strand has found perturbations of the predicted orbital motion in the visual binary 61 Cygni, which are believed by him to be caused by a third invisible member revolving about one of the two visible stars. According to Strand, the invisible companion has a mass one-sixtieth that of the sun, or sixteen times that of Jupiter; some astronomers prefer to consider it a planet rather than a star. Reuyl and Holmberg have found a similar companion to 70 Ophiuchi. These findings perhaps indicate the existence of "solar systems" other than our own. Van Biesbroeck has discovered a faint visible companion of absolute magnitude +19 (one-millionth as bright as the sun) to the single star B.D. +4° 4048; this companion is the faintest star directly observed.

Dwarf stars, normal stars, giants, supergiants, clouds of dust and gas all go to make up the Milky Way. But the fundamental building blocks for all material structures are tiny atoms, a few million-millionths of an inch in diameter. From atoms and molecules come the light rays that enable us to see and study the stars and nebulae. It is our good fortune that the kind of light emitted by atoms is controlled by their physical environment. Thus the light rays from galactic space carry with them vivid code messages of the climatic conditions in the stars and nebulae. We now turn to the story of how the message of star light is decoded.

STELLAR RAINBOWS

THE SPECTROSCOPE

*T*HE COMMONPLACE FACT THAT SUNLIGHT IS COMPOSED OF all the colors of the rainbow was discovered in 1666 by Sir Isaac Newton. He admitted sunlight into a darkened room,

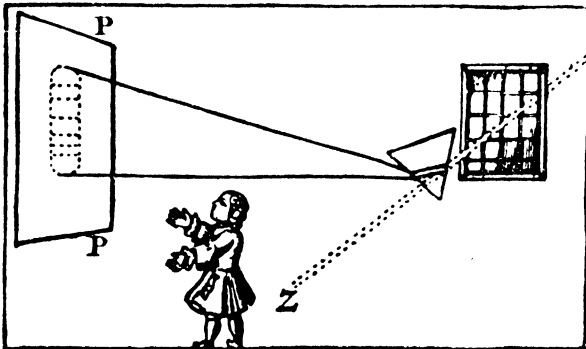

Fig. 8.---Newton's experiment.

(From Condon and Shortley "The Theory of Atomic Spectra," The Macmillan Company.)

(see Figure 8) and then allowed the light to pass through a triangular glass prism and to project itself on the wall some 20 feet away. In place of the original spot of white light,

there appeared a brilliant rainbow or *spectrum* of colors arranged in a band, violet at one end and changing slowly to blue, green, yellow, orange and finally to red at the other. Thus "white sunlight" was proved to be actually a mixture of all the colors of the rainbow.

The glass prism sorts out the separate colored rays by changing their directions by amounts which depend on the color of the light. We have various kinds of evidence that when a light ray passes from one medium to another, its direction usually changes. Thus, as in Figure 9, a stick half immersed in water appears broken in the middle.

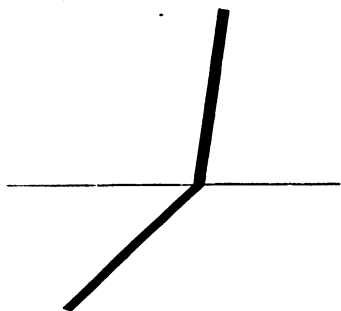
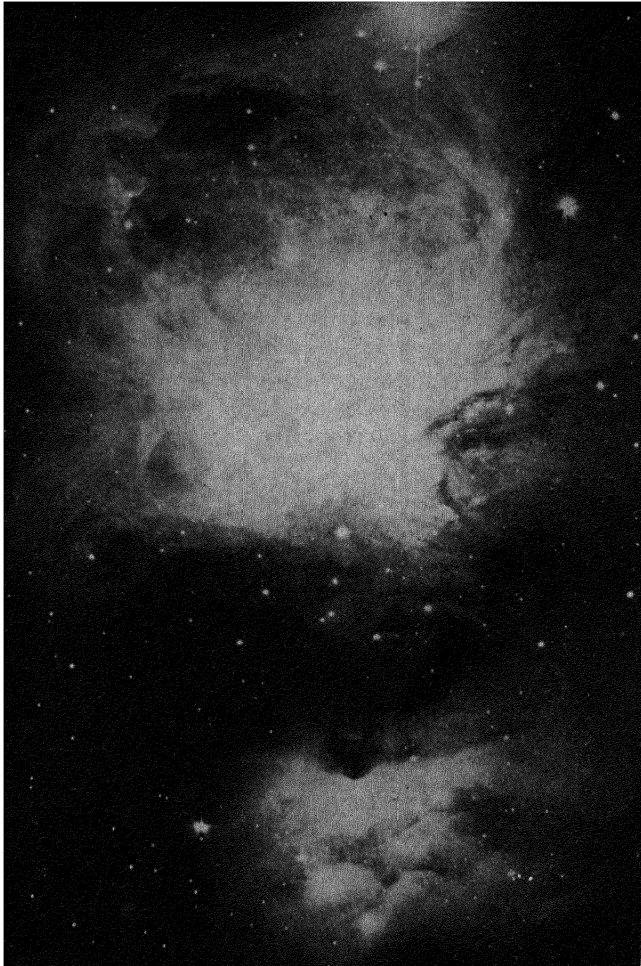

Fig. 9.—A "broken" stick in water.

If all the light rays were deviated by the same amount in traversing a prism, the emergent light beam would be uncolored. But the violet rays are bent more than the blue rays, the blue more than the green, the green more than the yellow, etc., with the result that the original white light is spread or dispersed into its component colors. Similarly, droplets of water in the earth's atmosphere act like tiny prisms and disperse the sunlight to produce the rainbow.

The modern spectroscope (see Figure 10) is essentially patterned after Newton's experimental arrangement. To prevent the overlapping of the separate colors, the light source is first focussed on a narrow slit, perhaps one-hundredth of an inch wide. After passing through the slit, the diverging beam is *collimated*, or made parallel, by a lens at *C*, and then directed through a glass prism, *D*. The lens *T* then brings the rays to a focus along the line *PP'*. The spectrum at *PP'* consists of a series of slit images, or "lines,"

ATOMS, STARS, AND NEBULAE



The Great Nebula in Orion.

This gaseous mass shines with light borrowed from the stars imbedded within it. The distance is about 300 light years, the density less than the highest vacuum we can produce on the earth. Photographed by N. U. Mayall with the Crossley Reflector of the Lick Observatory.

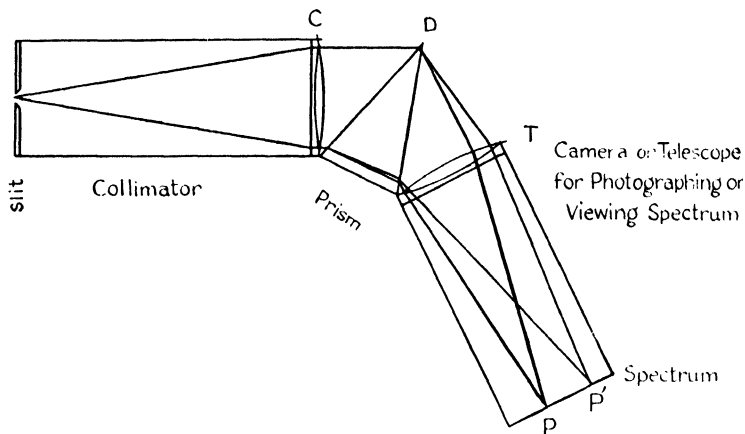

Fig. 10.—Schematic diagram of a spectroscope.

each of a different color; we may examine it with an eyepiece or photograph it upon a plate or film. But before discussing this instrument further let us look into the nature of color.

THE MEANING OF COLOR

Just what is meant by the color of a light ray? The sensation of color is purely subjective, resulting from the response of the retina to some physical property of light. Laboratory experiments have shown that light is propagated in the form of waves, at a speed of 186,000 miles per second. The distance between successive crests or troughs in the waves is known as the *wave-length*. The interesting property of light waves is that the phenomenon of color, which is a physiological sensation, is directly related to the length of the light wave; red light waves are the longest waves visible, the yellow ones are shorter, while the waves of violet light are the shortest that can be seen. The wave-length of red light, for example, is about 25 millionths of an inch, whereas the wave-length of violet light is only about 16 millionths of an

inch. The paths of two different light rays, one red and the other violet, are shown schematically in Figure 11. Both waves move from *A* to *B* in the same time, since the velocity of all light is the same in a vacuum. Since the violet ray has a shorter wave-length than the red ray, it undergoes a greater number of vibrations over the same distance. The number of such vibrations per second, or the *frequency* of the

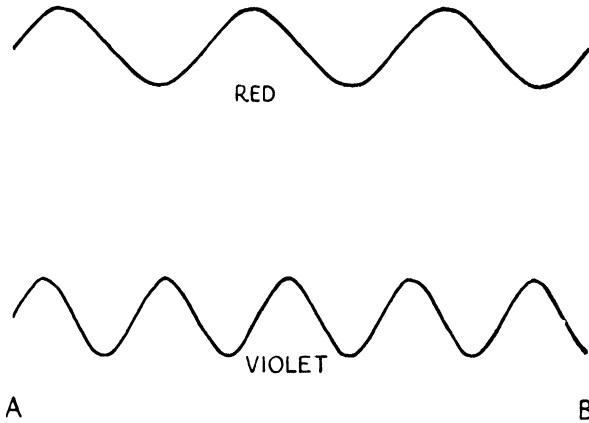

Fig. 11.—Light waves of red and violet.

light wave, is equal to the velocity of light divided by the wave-length. Thus the frequency of short-wave violet light, which is 750 million million vibrations per second,* is $2\frac{5}{16}$ times that of the longer-wave red light. Wave-lengths are usually expressed in angstrom units, named in honor of the Swedish physicist, A. J. Ångström. One angstrom (abbreviated A) is equal to four thousand-millionths of an inch or a hundred-millionth of a centimeter.

The limited color sensitivity of the human eye confines the visible portion of the spectrum to a strip extending from

* This number is usually abbreviated to read 7.5×10^{14} , where 10^{14} signifies the number 1 followed by 14 zeros. Similarly, the reciprocal of 10^{14} is written 10^{-14} .

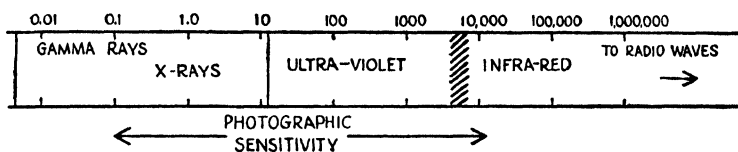

Fig. 12.—The radiation spectrum.

The cross-hatched section is that portion of the spectrum visible to the human eye.

4000A in the violet region to about 7000A in the red. However, various mechanical devices for recording energy, e.g. the photographic plate and the photoelectric cell, have shown that the radiation spectrum (see Figure 12) extends far on either side. The shortest wave-lengths that have been recorded are those of the high-frequency X-rays, in the neighborhood of one or two angstroms, and the gamma rays, emitted by substances like radium, while the long radiation waves, far beyond the red or even the infra-red, merge continuously into the region of radio waves, hundreds of meters long.

ATOMIC THUMB PRINTS

Newton's discovery that a light source like the sun radiates a brilliant spectrum of color, although artistically appealing, is hardly as significant as the fact that different types of light sources are characterized by different types of spectra. The laws of spectrum analysis popularly known as Kirchhoff's laws are of fundamental importance in our problem. Suppose that, simulating the experiments of Kirchhoff and Bunsen, we were to place the glowing white-hot tungsten filament of an incandescent lamp before the slit of a spectroscope. We would find that the spectrum consists of a bright, continuous band of colors, very similar, in fact, to the rainbow. A piece of iron, or any other solid, heated to red or white heat, but not vaporized, likewise displays a continuous

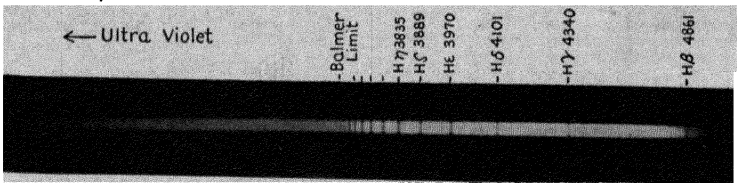

Fig. 13.—The ultraviolet spectrum of a hot star.

The Balmer series of Hydrogen is very conspicuous in this star, π_1 Cygni (H.D. 206672). The lines appear as dark (absorption) lines upon the continuous spectrum of the star. Notice how the lines grow closer and closer together until they reach a limit beyond which there is a uniform continuous absorption. (*Lick Observatory*.)

spectrum. But now if we employ as our light source a glass tube filled with rarefied glowing hydrogen, we observe a spectrum radically different from that of a shining solid. In place of a brilliant continuum are four bright, colored lines, or slit images, red, green, blue, and violet, the latter just above the limit of visibility at 4102A. We note that the spaces between the lines appear black, and also that there is a remarkable regularity in the positions of the lines, with the separations between successive bright images decreasing steadily from red to violet. On the photographic plate, the series continues on into the ultraviolet, with the lines crowding ever closer together until they terminate near 3650A (see Figure 13). The spectrum of heated sodium vapor likewise shows discrete bright lines, notably a pair close together in the yellow and a series in the ultraviolet. Other glowing gases, too, radiate bright-line spectra, but each element, be it hydrogen, helium, sodium, calcium, iron, lead, or radium, is marked by a different set of radiations, which the spectroscope sorts out as bright lines. Because no two elements display identical spectra, we see that nature has provided us with the means for fingerprinting every element. Once the spectra of the known elements have been recorded in the laboratory, the composi-

tion of any mixture may be ascertained, regardless of whether the sample to be analyzed is located on the earth or in a distant star or nebula.

If we now interpose sodium vapor between a tungsten filament and the slit of the spectroscope, we obtain still a third type of spectrum. In the visible part of the spectrum the brilliant continuum of color from the incandescent lamp appears unchanged except for two dark lines at precisely the same wave-lengths at which the bright sodium lines had been seen before. In Figure 14 we show the bright-line or emission spectrum of sodium in the invisible ultraviolet, and also the dark-line absorption spectrum with a carbon arc as the source of continuous radiation. The cooler sodium vapor has evidently absorbed light from the bright background, but only in those wave-lengths which it is capable of emitting. Similar results are obtained for other vaporized elements; their characteristic spectra appear as dark rather than as bright lines.

Experiments of the sort we have described led to the formulation of Kirchhoff's three laws of spectroscopy: (1) an incandescent, i.e. glowing, solid or liquid (or very dense gas) radiates a *continuous spectrum*; (2) a rarefied gas emits a characteristic bright-line or *emission spectrum*; (3) the spec-

Fig. 14.—The ultraviolet spectrum of sodium vapor.

Kirchhoff's second and third laws of spectroscopy are illustrated with sodium vapor and the carbon arc. In (a) above, light from the carbon arc is passed through a heated tube containing sodium vapor. The lines of sodium vapor appear as dark lines on a (nearly) continuous background. In (b) the pole pieces of the carbon arc are drilled and filled with sodium carbonate. We then obtain the bright line spectrum of sodium. A few bright lines of the carbon arc are visible in both photographs.

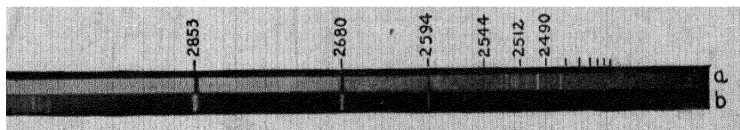

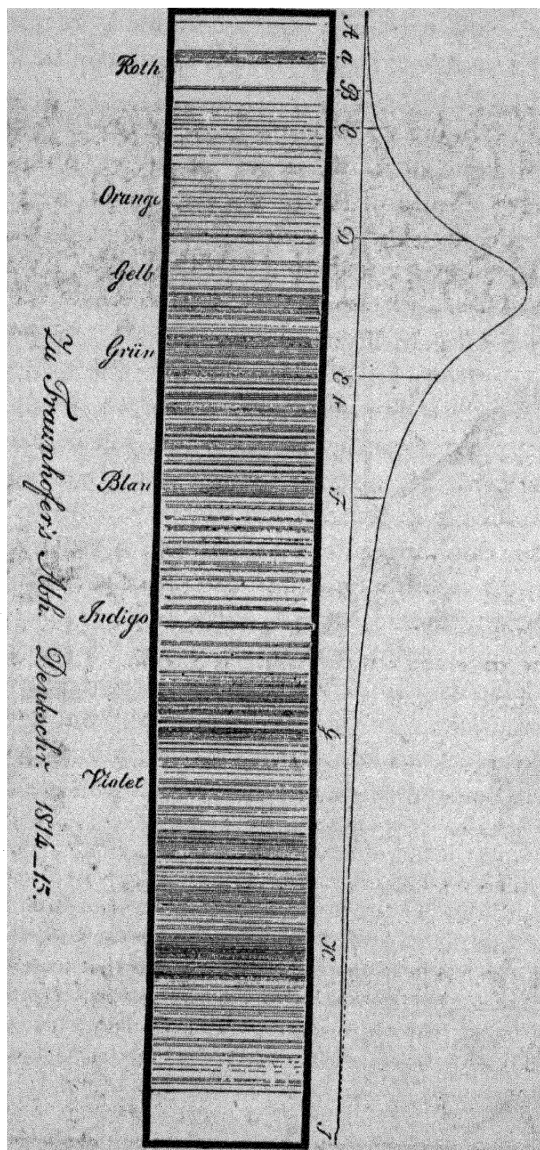

Fig. 15.—Fraunhofer's map of the solar spectrum.

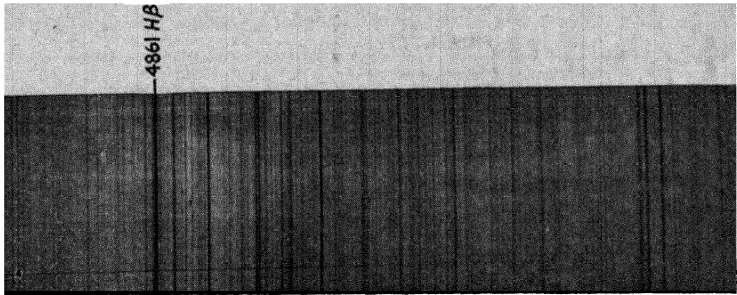

Fig. 16.—A portion of the solar spectrum in the neighborhood of the blue hydrogen line. (λ 4861 H β)

(From a photograph by Menzel.)

trum of a gas placed in front of a hotter source of continuous radiation consists of *dark* absorption lines at just those wave lengths that it regularly emits.*

Kirchhoff recognized that the sun and the stars must be intensely hot bodies, surrounded by relatively cooler, thinner atmospheres (see Figure 17). The elements comprising the gaseous atmosphere, or *reversing layer*, of a star evidently absorb the bright, continuous radiation flowing

* In 1802, Wollaston, repeating Newton's experiment, found four dark lines in the spectrum of the sun and interpreted the lines as divisions separating the colors of white light: red, yellow-green, blue, and violet. Spectra of the sun obtained through liquid prisms containing nitric acid, oil of turpentine, oil of sassafras and Canada balsam were similar, showing that the spectra did not depend on the dispersing medium. About 1815, Fraunhofer mapped 574 lines in the spectrum of the sun. A section of the map is shown in Figure 15. The suggestion that these lines were caused by absorption in the atmosphere of the earth was disproved when Fraunhofer found that the spectra of several bright stars were quite unlike that of the sun (see Figure 23). He also noticed agreements between the positions of lines of terrestrial elements and the dark lines of the solar and stellar spectra, but unfortunately attached no significance to the coincidences. In Figure 16 we reproduce a portion of the solar spectrum in the neighborhood of the blue hydrogen line at 4861A.

from the lower surface, or *photosphere*, and thus imprint their dark lines upon the spectrum. The spectroscope revealed each star as a gigantic laboratory in which matter could be studied under extreme physical conditions not attainable on the earth. Sir William Huggins, an English amateur, examined the spectra of a large number of stars,

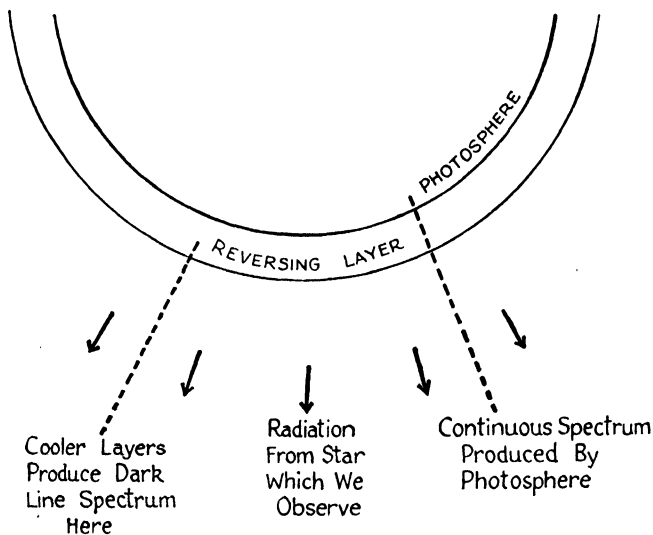

Fig. 17.—Schematic diagram of the photosphere and reversing layer of a star.

comparing the positions of the dark lines with those of bright lines emitted by elements in the laboratory. He found many coincidences and concluded that matter everywhere in the universe must be alike. The great Orion Nebula (see Figure 18), believed by many astronomers to be an aggregation of stars too far away and too close to one another to be resolved by existing telescopes, was expected to show a continuous spectrum. Huggins found instead, to his astonishment, that the spectrum consisted entirely of a

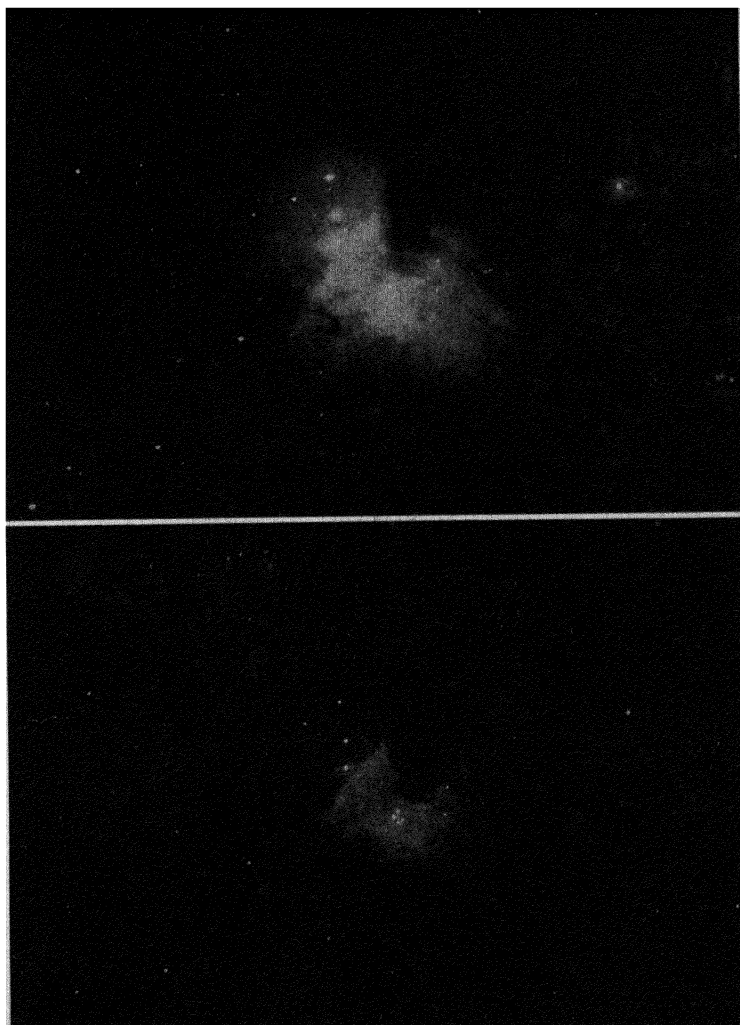

Fig. 18.—The great nebula in Orion.

Photographed in blue and red light at the southern station of the Harvard Observatory by Dr. J. S. Paraskevopoulos. The (upper) blue photograph required 3 minutes; the (lower) red one required 10 minutes. The four stars of the Trapezium are clearly visible.

few bright lines. The Orion Nebula was thus shown to be not a cluster of stars, but a single great cloud of tenuous gas.

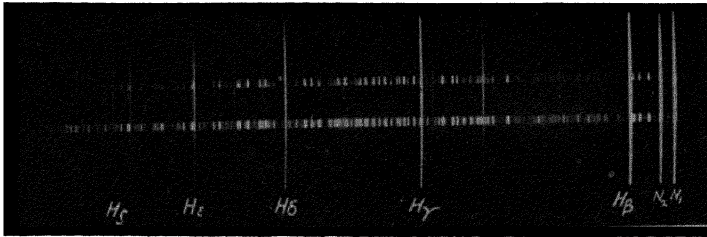

Fig. 19.—The spectrum of the great nebula in Orion. The two narrow central strips are laboratory spectra, for comparison.

(Mount Wilson Observatory.)

SORTING THE STARS

While Huggins was interested in the chemical composition of the stars, Father Secchi, at Rome, was attracted by the diversity in appearance among stellar spectra. Some, like the sun, featured large numbers of lines of metallic elements, notably calcium, sodium, and iron. Others showed only broad lines of hydrogen, while still others, the red stars, exhibited a wealth of complex detail, characterized by dark fluted bands. Secchi found that he could arrange the vast majority of stellar spectra into four distinct types, with all the stars in each group sharing roughly the same spectral features. This contribution was very important, for if the spectrum of a star were related to its physical characteristics, and all the stars fell into one of four classes of spectra, the detailed study of one star might reveal the characteristics of many more.*

* Secchi found that stars whose brightnesses fluctuated irregularly belonged to the class showing fluted spectra. Stars of Type I, i.e. the blue and white stars, showed some tendency to collect in certain parts of the sky. For example, five of the stars in the Big Dipper, which form a physical cluster of stars moving through space in the same direction and with the same speed, are of this type.

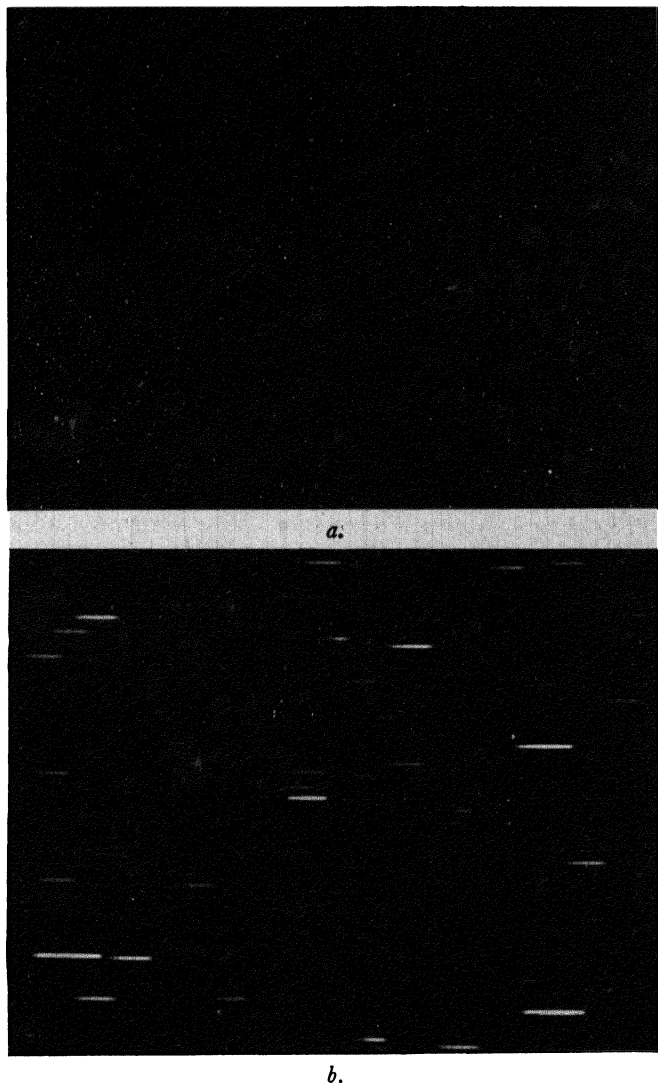

Fig. 20.—Direct and objective prism photographs of the same star field compared.
(Harvard Observatory.)

Secchi's achievement was remarkable, considering that his observations were made visually, during long hours at the telescope. With the advent of photography, E. C. Pickering, Director of Harvard College Observatory, embarked on a huge program of spectral classification, with the collaboration of Mrs. Fleming, Miss Maury and Miss

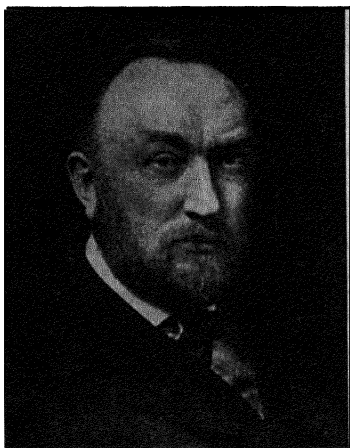

Fig. 21.—E. C. Pickering of Harvard.

Cannon. Pickering placed a large glass prism in front of the telescope objective, and used the lens as a camera to focus the spectrum on the photographic plate. The advantage of the objective-prism technique is that a great many spectra may be photographed on a single plate, as in Figure 20, whereas the slit spectrograph records one spectrum at a time.

The aim of the Harvard classification was to group the stars in such a way that the spectral features of one group merged as smoothly as possible into those of the next adjacent group. As the dark lines of hydrogen seemed to be common to all stellar spectra, the original plan called for labelling as Class *A* the stars with the most intense hydrogen lines, those with the next strongest hydrogen lines class *B*, and so on down to classes *M* and *N*, where the hydrogen lines are very weak. This scheme had to be modified for a number of reasons. Some of the classes, e.g. *C*, *D*, *H*, had been derived from out-of-focus photographs and were unnecessary. Also the arrangement in order of decreasing hydrogen line intensities produced discontinuities in the

trends of other spectral lines. Class *O*, discovered later, was found to belong at the beginning of the sequence. As finally adopted, the classes follow the order *O*, *B*, *A*, *F*, *G*, *K*, and *M*. In addition a few stars classified as *N*, *R*, and *S* appear to represent side branches jutting off from the main sequence near class *K*.*

The photographic plate shows such a wealth of detail that it has been necessary to subdivide each of the Harvard classes into sub-divisions by affixing a number from 0 to 9 to each letter; thus the dark-line pattern of spectral class *A5* lies midway between those of *A0* and *F0*. According to this system the sun was classified as *G0* in the Henry Draper catalogue.

In Figure 23 we have arranged a number of typical stellar spectra photographed at the Yerkes Observatory to show the main features of the sequence. Notice how the spectra grow in complexity from classes *O* to *M*. Beginning with class *O*, the hydrogen lines grow steadily stronger, reach their peak of distinction at class *A0*, and then sink into obscurity. Classes *O* and *B* bear the imprint of helium, which is absent from the spectra of later types. The lines of the metals like calcium, sodium, and iron are first

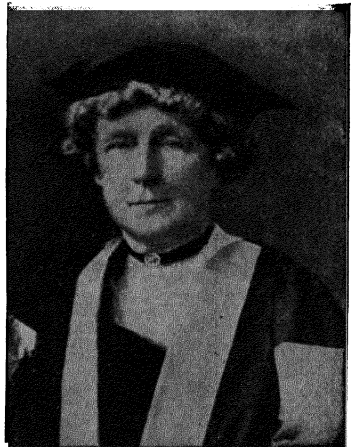

Fig. 22.—Annie J. Cannon of Harvard.

* If the reader finds it difficult to adjust his memory to this peculiar arrangement of letters, we venture to suggest that the sentence: "Oh, Be A Fine Girl, Kiss Me Right Now, Sweet!" has already proven its worth.

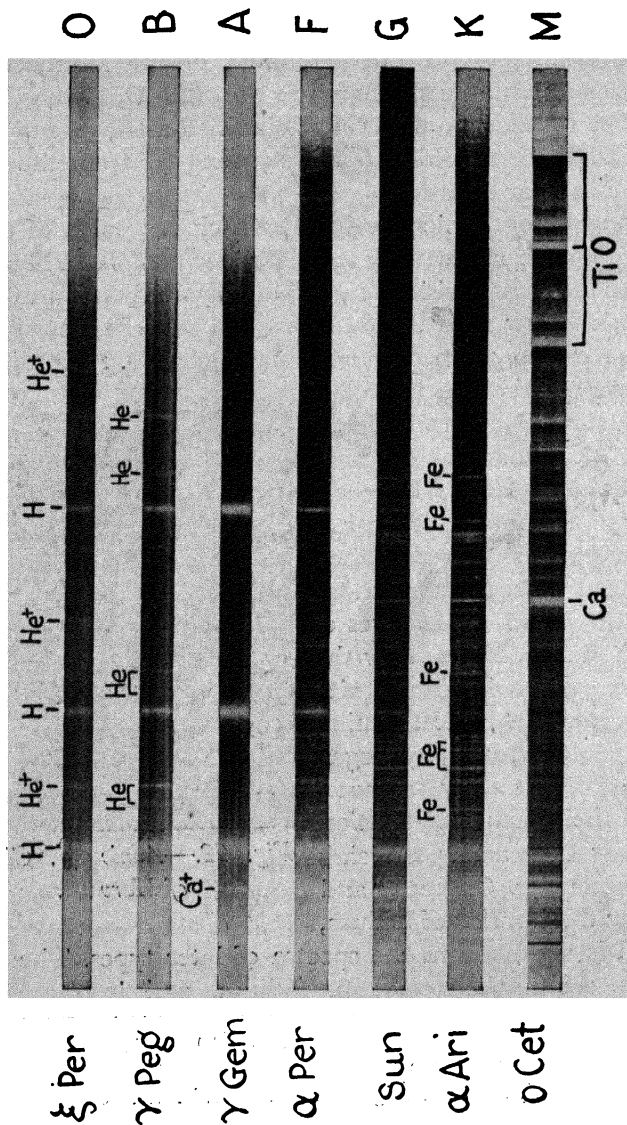

Fig. 23.—The spectral sequence (negative prints).

(From a compilation by W. W. Morgan at the Yerkes Observatory.)

noticeable in class *A* and rapidly grow in strength and numbers through classes *F*, *G*, and *K*. The broad bands of molecular compounds creep into the picture in classes *G* and *K*, becoming the outstanding landmarks on the spectroscopic map in classes *M*, *N*, *R*, and *S*.

A very significant aspect of the spectral classification is that it also segregates the stars according to color. Furthermore, the colors along the sequence are arranged somewhat like those in a spectrum, the blue stars occurring at the beginning and the red stars at the end of the sequence. Thus the bright blue stars in the constellation of Orion are of class *B*. Sirius, a whitish star, is of class *A0*, while the southern beauty, Canopus, is of class *F0*. Capella, brightest of northern stars and yellow like the sun, is of class *G0*; Arcturus, the bright orange star of spring and summer is of class *K0*; and Betelgeuse and Antares, red stars of Orion and the Scorpion, respectively, are *M* stars.*

We emphasize that the classification of stellar spectra was carried out solely on the basis of the appearance of the spectra, without regard to the physical causes that might be responsible. Huggins and other early workers tended to believe that the differences were due mainly to variations in chemical composition. If the blackness of a spectral line depended only on the abundance of the responsible atom, we could easily arrange the stars in order of steadily changing hydrogen abundance. But it would be a remarkable coincidence indeed if stars arranged on this basis also showed smoothly varying abundances of all other elements, and if the hydrogen stars were always blue and the metallic

* The actual determination of the spectral class of a star depends upon the relative intensities of certain lines. The helium lines (in the hotter stars), the hydrogen lines, the *K* line of ionized calcium (see Chapter 4), and the 4227 line of neutral calcium are among the lines used for this purpose.

stars red. We shall show in Chapter 4 that these variations are due, not to changes in chemical composition, but to diversities in physical conditions, such as temperature and density.

THE SPECTROSCOPE AS A SPEEDOMETER

Not only does the spectroscope reveal the compositions of stars, but also their speeds towards or away from the observer. To understand how the spectroscope can act as a speedometer, the reader should recall the high-pitched whistle that heralds the approach of a speeding train, and the sudden transition to a long, drawn-out wail that accompanies its passing and recession. When the train is at rest, the whistle emits sound waves of a definite pitch and wave-length. The number of waves per second that strike the ear depends upon the pitch of the sound. But when the train is in rapid motion towards the listener, the individual waves tend to crowd up on each other, and a greater number fall upon the ear every second. The increase in the number of vibrations per second is interpreted by the ear as an increase in pitch. Conversely, when the train is receding, the sound waves are drawn out and fewer of them per second strike the ear, which perceives that the pitch has diminished.

If light is propagated as a wave-motion, a similar effect should operate, as pointed out by Christian Doppler in 1842. Suppose that a source emits light of a certain frequency, which passes through the spectroscope and appears as a spectrum line. The wave-length determines the position of the spectrum line; but when the light source is racing towards the observer, the light waves appear to oscillate more rapidly and the wave-length seems shorter. Consequently, the spectral line is shifted to the violet of its normal position. And when the light source is receding, the line

moves over toward the red. The magnitude of the shift, which is known as the *Doppler effect*, is related to the speed of the light source by*

$$\frac{\text{Change of wave-length}}{\text{normal wave-length}} = \frac{\text{speed of source}}{\text{speed of light}}$$

Thus, for example, the speed of light is 186,000 miles/sec. and if the light source is receding at 18.6 miles/sec., the position of a line at 5000A is shifted by 0.5A, an amount easily detected.

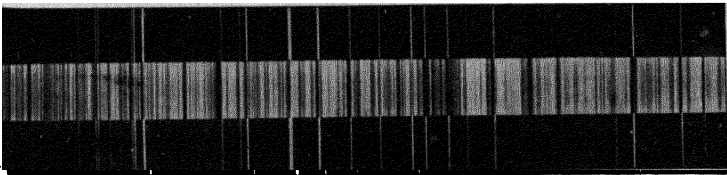

Fig. 24.—The radial velocity of a star.

This spectrogram of ϵ Andromedae (spectral class G5) is photographed between a pair of titanium comparison spectra. The stellar lines are displaced to the left about $\frac{1}{32}$ inch due to the radial velocity of the star, which in this case amounts to 103 km/sec towards us. (*Lick Observatory*.)

To clock the speed of a star, the spectrum lines of a laboratory source—iron, titanium, helium, etc.,—are impressed on a photographic plate on either side of the stellar spectrum to serve as reference points for measuring the positions of stellar lines. The astronomer then determines the displacements in angstrom units of the stellar lines with respect to the comparison lines. From these displacements he obtains the velocity of the star. The spectroscope thus gives the radial velocity, the amount of motion along the line of sight, just as the progressive displacement of a star's

* It makes no difference whether the light source or the observer is in motion. The important fact is the rate at which the two are approaching or receding from one another.

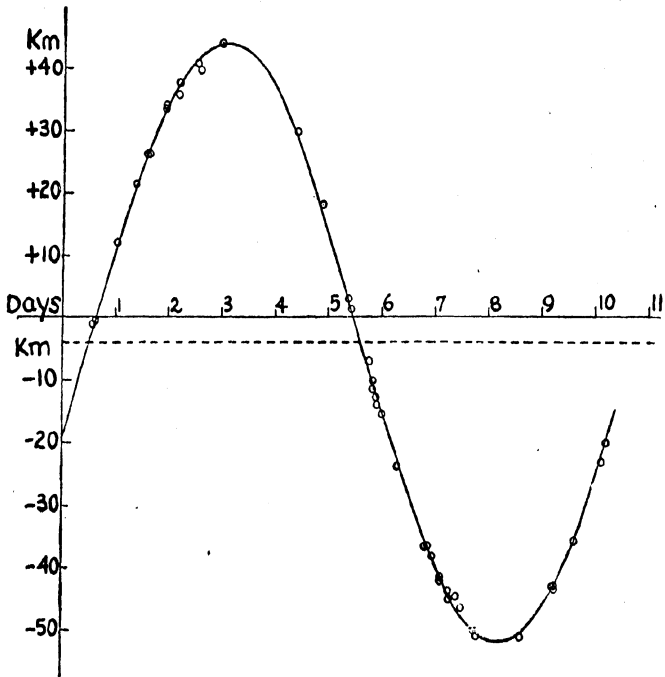
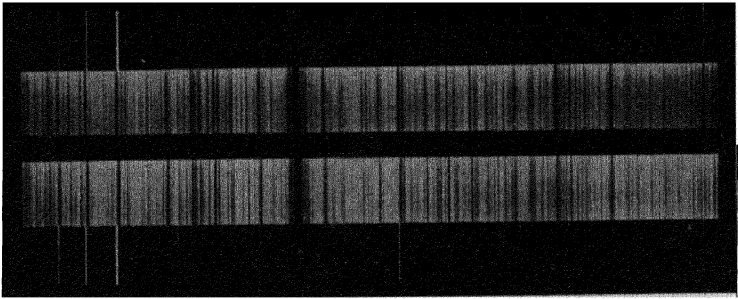

Fig. 25.—The spectrum and radial velocity curve of a spectroscopic binary, ι Pegasi.

In this case the spectrum of only one star is visible. (Lick Observatory.)

position on the celestial sphere measures its speed at right angles to the line of sight. The combination of the two completely defines the direction and speed of motion of the star relative to the earth. Figure 24 shows how the radial velocity of a star causes a shift in the positions of spectral lines. Radial velocities have received special attention at the Lick, Mount Wilson, Victoria, and Yerkes Observatories.

The spectroscope as a speedometer has also had important application in studies of the orbital motions of double stars. The components of many double stars are so close together that they cannot be separated by direct observation. When the plane of the orbit is tilted even slightly in the direction of the line of sight, each star appears now approaching, now receding, as it whirls about its companion. If the two stars are almost equally bright, the spectrum will exhibit a periodic doubling of the lines, when one star is approaching and the other is receding. Usually, however, as with Iota Pegasi (Figure 25), one star is so much brighter than the other that only a single spectrum is seen and the lines of this spectrum oscillate to and fro as the velocity of the star with respect to the observer changes. A star whose duplicity is recognized from its spectrum is known as a *spectroscopic binary*. Mizar, the star at the bend of the handle of the Big Dipper, was the first star of this class to be detected, by E. C. Pickering in 1889. Several hundred others have since been discovered. A catalogue by J. H. Moore, of Lick Observatory, gives the orbits for 375 spectroscopic binaries.

3

ATOMS AND MOLECULES— STELLAR BUILDING BLOCKS*

ATOMS AND RADIATION

WHERE DOES LIGHT ORIGINATE? WHEN WE PRESS A button at home, electrical energy flows through a wire and is somehow converted into light radiating from a tungsten filament. In some way, tiny atoms, which are the building blocks of all forms of matter, generate light of various colors or wave-lengths when fed with fuel in the form of chemical or electrical energy. By what operation inside the

* It may be worthwhile to recall here the differences between atoms and molecules. The chemists have shown that the many gases, liquids, and solids which make up the world are composed of the pure forms or combinations of 92 fundamental substances, called *elements*, which may combine to form *compounds*. Thus water is composed of hydrogen (two parts by volume) and oxygen (one part by volume). The smallest particle of an element is an *atom* while the smallest particle of a compound is a *molecule*. The molecule of water consists of two hydrogen atoms bound to one oxygen atom, thus HOH. We must distinguish between mixtures or *alloys*, e.g. vanadium and iron, in which the atoms are loosely mixed with one another, and compounds, where the individual atoms of a molecule are tightly bound together.

atom is that light generated and why do different kinds of atoms radiate energy in different wave-lengths?

Atoms are much too small to be seen so that experiments to find out their structure and behavior have to be conducted with large numbers of atoms; from the results of these experiments we may attempt to construct a hypothetical model of an atom that behaves like the true atom. Many such atomic models have been proposed in the past and have had varying degrees of success in reproducing the observed features of spectra. But all of them, at one time or another, have led to contradictions with experiments. These failures have led to the conclusion that no purely mechanical model of the atom is entirely satisfactory; the laws of mechanics that govern the operations of large bodies apparently break down when applied to ultra-microscopic particles. Entirely new laws of mechanics have had to be devised to cope with the behavior of atoms. These laws are embodied in the so-called *wave mechanics*, or *quantum mechanics*, which have thus far given a completely successful account of atomic behavior. The operation of these laws, although perfectly straightforward mathematically, is somewhat difficult to visualize. For this reason, even the scientist, who makes his calculations according to the mathematical laws of quantum mechanics, frequently thinks of the atom in terms of some simple mechanical model.

WHAT ATOMS ARE MADE OF

Experiments in the laboratory have shown that the chief materials of atomic construction are three fundamental particles which have been labelled *neutrons*, *protons*, and *electrons*. The electron, which carries a negative electric charge, is the lightest particle known in nature. It would take 311×10^{26} (i.e. 311 followed by 26 zeros) of them to weigh one ounce. Expressed in grams, the mass of an

electron is 9.11×10^{-28} (28.35 grams = 1 oz.). The neutron and the proton are equal in mass, weighing 1837 times as much as an electron. Each of them weighs 1.672×10^{-24} grams. A piece of dust a thousandth of an inch in diameter would still weigh a thousand million million times as much as a proton. But, whereas the proton carries a positive electric charge equal in numerical magnitude to that of the electron, or $+1$, the neutron, as its name implies, is electrically neutral.*

According to modern theory, protons and neutrons are grouped together to form a closely packed *nucleus*, which is surrounded by one or more outer electrons. Thus in helium, two protons and two neutrons are jammed together to form a very compact nucleus. Around this nucleus move two electrons. [A small amount of atomic matter occupies a relatively enormous volume of space, for the electrons are probably separated from the nucleus by distances of the order of thousands of times the diameter of the nucleus.] The cement that binds the atomic structure together is the force of electrical attraction between the positive and negative charges. It is this attractive force that keeps atoms electrically neutral. Strip an atom of its electrons and the nucleus continually strives to capture others until the electrical balance is restored.

The number of protons and neutrons that constitute any nucleus, say that of an iron atom, may be learned from two observable quantities, namely the mass and the number of outer electrons. Since the proton and neutron weigh so much more than the electron, the total number of them in a nucleus determines the mass of the atom. Of this total, for a neutral atom, enough must be protons to equal the

*The electric charge associated with atomic particles is conveniently expressed in terms of the charge of the electron, which is taken as -1 . In the electrostatic system of units this charge is 4.80×10^{-10} .

number of outer electrons and thereby provide electrical neutrality. The lightest of all elements is hydrogen, with a nucleus composed of a single proton, and therefore with one outer electron and no neutron. The hydrogen atom weighs 1.673×10^{-24} grams, which is a bit larger than the mass of one proton. A helium atom weighs four times as much as hydrogen, and with two outer electrons, contains two protons and two neutrons within its compact nucleus. Oxygen atoms are sixteen times as massive as hydrogen atoms; they consist of eight protons, eight neutrons, and therefore eight outer electrons.

The spectra and chemical properties of an atom depend essentially only on the number of the outer electrons. The differences in chemical properties between potassium, which has 19 outer electrons, and calcium which has twenty, are well known. Likewise the spectra emitted by calcium and potassium are entirely different. Disturbances of an atom's outer electrons by means of collisions with other atoms or with a stream of electrons in an arc produce the spectral lines we observe in a flame or electric arc. To disturb the nucleus we must resort to far more drastic measures (see Chapter 12).

Ninety-two separate elements are known (see Table 1). Each atom has been given a number corresponding to the number of its outer electrons; thus the atomic number of hydrogen is 1, that of helium is 2, oxygen 8, and uranium 92. The masses of atoms are usually expressed on a relative scale, which is based upon an adopted atomic weight of 16 for oxygen. Since oxygen contains 16 protons and neutrons the mass of each of these particles must be unity. Why is it, then, if atoms are made up of integral numbers, 1, 2, 3, etc., of the fundamental particles, that the atomic weights listed in Table 1 are not integers? It so happens that two or more electrically neutral atoms may be of the same

TABLE I
THE CHEMICAL ELEMENTS

<i>Element</i>	<i>Sym- bol</i>	<i>Atomic number</i>	<i>Atomic weight</i>	<i>Element</i>	<i>Sym- bol</i>	<i>Atomic number</i>	<i>Atomic weight</i>
Hydrogen	H	1	1.008	Silver	Ag	47	107.88
Helium	He	2	4.004	Cadmium	Cd	48	112.41
Lithium	Li	3	6.94	Indium	In	49	114.76
Beryllium	Be	4	9.02	Tin	Sn	50	118.70
Boron	B	5	10.82	Antimony	Sb	51	121.76
Carbon	C	6	12.01	Tellurium	Te	52	127.61
Nitrogen	N	7	14.01	Iodine	I	53	126.92
Oxygen	O	8	16.00	Xenon	Xe	54	131.3
Fluorine	F	9	19.00	Cæsium	Cs	55	132.91
Neon	Ne	10	20.18	Barium	Ba	56	137.36
Sodium	Na	11	23.00	Lanthanum	La	57	138.92
Magnesium	Mg	12	24.32	Cerium	Ce	58	140.13
Aluminum	Al	13	26.97	Praseodymium	Pr	59	140.92
Silicon	Si	14	28.06	Neodymium	Nd	60	144.27
Phosphorus	P	15	31.02	Illinium	Il	61	
Sulphur	S	16	32.06	Samarium	Sm	62	150.43
Chlorine	Cl	17	35.46	Europium	Eu	63	152.0
Argon	A	18	39.94	Gadolinium	Gd	64	156.9
Potassium	K	19	39.10	Terbium	Tb	65	159.2
Calcium	Ca	20	40.08	Dysprosium	Dy	66	162.46
Scandium	Sc	21	45.10	Holmium	Ho	67	163.47
Titanium	Ti	22	47.90	Erbium	Er	68	167.64
Vanadium	V	23	50.95	Thulium	Tm	69	169.4
Chromium	Cr	24	52.01	Ytterbium	Yb	70	173.04
Manganese	Mn	25	54.93	Lutecium	Lu	71	175.0
Iron	Fe	26	55.84	Hafnium	Hf	72	178.6
Cobalt	Co	27	58.94	Tantalum	Ta	73	180.88
Nickel	Ni	28	58.69	Tungsten	W	74	184.0
Copper	Cu	29	63.57	Rhenium	Re	75	186.31
Zinc	Zn	30	65.38	Osmium	Os	76	191.5
Gallium	Ga	31	69.72	Iridium	Ir	77	193.1
Germanium	Ge	32	72.60	Platinum	Pt	78	195.23
Arsenic	As	33	74.91	Gold	Au	79	197.2
Selenium	Se	34	78.96	Mercury	Hg	80	200.61
Bromine	Br	35	79.92	Thallium	Tl	81	204.39
Krypton	Kr	36	83.7	Lead	Pb	82	207.21
Rubidium	Rb	37	85.48	Bismuth	Bi	83	209.00
Strontium	Sr	38	87.63	Polonium	Po	84	210
Yttrium	Y	39	88.92			85	
Zirconium	Zr	40	91.22	Radon	Rn	86	222
Columbium	Cb	41	92.91			87	
Molybdenum	Mo	42	96.0	Radium	Ra	88	226.05
Masurium	Ma	43		Actinium	Ac	89	227
Ruthenium	Ru	44	101.7	Thorium	Th	90	232.12
Rhodium	Rh	45	102.91	Protoactinium	Pa	91	231
Palladium	Pd	46	106.7	Uranium	U	92	238.07

atomic number, and yet have different masses corresponding to different numbers of neutrons in the nucleus. Such atoms are said to be isotopes of the same element. The atomic weight of each isotope is nearly an integer, but since each element contains a mixture of isotopes, its *average* atomic weight need not necessarily be a whole number. Practically all elements have isotopes. Carbon, for example, has two, each containing six protons, but one with six neutrons and the other with seven neutrons; the atomic weights are 12.004 and 13.008 respectively. By far the most abundant carbon isotope is of atomic weight 12, hence the average atomic weight of carbon is 12.006. Carbon 13, as it is called, is scarcely more than a trace of adulteration in the predominant pure carbon 12. Since the spectra of atoms depend essentially on the numbers of their outer electrons, the spectra of different isotopes of the same element are nearly identical.

To explain how atoms radiate light, we shall rely on an atomic model, that has served physicists for many years in the visualization of the behavior of the electrons within an atom. In the representation that we shall describe, the electrons are pictured as revolving about the nucleus in much the same fashion as the planets revolve about the sun. But whereas the planets are prevented from escaping into space by the sun's gravitational attraction, the electrons are held within the atom by the force of electrical attraction between the positively-charged nucleus and the negatively-charged electron. Such a model closely reproduces the behavior of the hydrogen atom but must be modified to explain, even qualitatively, the behavior of more complex atoms.

When we speak of atomic behavior, we refer to the fact that each atom emits and absorbs light of certain wave-

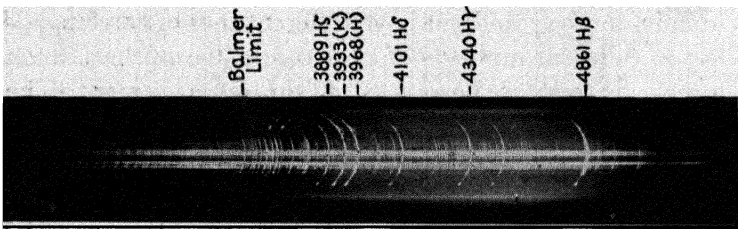

Fig. 26.—The Balmer series of hydrogen in the solar chromosphere.

This photograph is taken at the time of solar eclipse just as the moon cuts off the light from the disk of the sun, leaving the reversing layer and chromosphere visible. (A spectrogram taken at the solar eclipse of August 30, 1932, Fryeburg Maine, by D. H. Menzel of the Lick Observatory eclipse expedition.)

lengths. For example, consider the hydrogen atom. The spectrum of this element in the discharge tube and in the stars is characterized by a precise regularity. The strongest line is the red line at 6563Å, followed by the blue line at 4861Å, the violet 4340 line, and a sequence of others gradually drawing closer together until they merge near 3650Å. Balmer, in 1885, showed that the wave-lengths, λ , of the hydrogen lines could be accurately represented by the simple formula:

$$\frac{1}{\lambda} = R \left[\frac{1}{2^2} - \frac{1}{n^2} \right]$$

where n assumes successively the values, 3, 4, 5, 6, . . . and R is a constant.* The wave-lengths of the successive

* Lyman found a far ultraviolet series of hydrogen, beginning at 1216Å and ending at 912Å, whose wave-lengths could be represented by the formula: $\frac{1}{\lambda} = R \left[\frac{1}{1^2} - \frac{1}{n^2} \right]$ with $n = 2, 3, 4, 5, \dots$ etc. and R the same constant. Paschen discovered a series of infrared lines which could be represented by $\frac{1}{\lambda} = R \left[\frac{1}{3^2} - \frac{1}{n^2} \right]$, with $n = 4, 5, 6, \dots$ and Brackett discovered a far infrared series that obeyed the formula $\frac{1}{\lambda} = R \left[\frac{1}{4^2} - \frac{1}{n^2} \right]$ with $n = 5, 6, 7, 8, \dots$ etc.

members of the series, beginning with the red line, are computed from the formula by setting $n = 3, 4, 5, 6$, etc. Over 30 members of this series, known as the Balmer Series, have been observed in the spectra of certain stars and of the sun's outer atmosphere, the *chromosphere* (see Figure 26).

BOHR'S MODEL OF THE ATOM

In 1913, Niels Bohr successfully explained the various hydrogen series by suggesting an atomic model in which the electron travels in a circular orbit about the proton. In his picture of the hydrogen atom, the motion of the electron is subject to very specific traffic rules, for only a restricted set of orbits is allowed—those whose radii are proportional to the squares of integers from one to infinity (see Figure 27), i.e. to 1, 4, 9, 16, . . . etc.

In each of these orbits the energy of motion, or kinetic energy, of the electron is just balanced by the force of attraction that is exerted by the nucleus and prevents the electron from escaping. If an electron travelling in some particular orbit is to be made to travel in an orbit more distant from the nucleus, it must be supplied with energy from some outside source, because work must be done to pull the electron away from the nucleus that attracts it. A jostling encounter with another atom or the seizure of a passing light pulse may suffice to do the trick. But atoms are fussy; the electron will not change orbits unless it takes up precisely the required amount of energy, no more and no less, to remove it to one of the other "allowed" orbits. Bohr showed that if the amount of energy required to pull the electron from the ground or lowest orbit entirely free of the nucleus is represented by the symbol W , the amount of energy required to pull the electron out of the second orbit is $W/4$, from the third $W/9$, etc. In other words, the energies required are proportional to W/n^2 where $n = 1, 2, 3, \dots$

etc. If, for convenience, we call the energy zero when the electron is completely removed from the atom and at rest, the energy when the atom is in the lowest orbit is $-W$ (minus

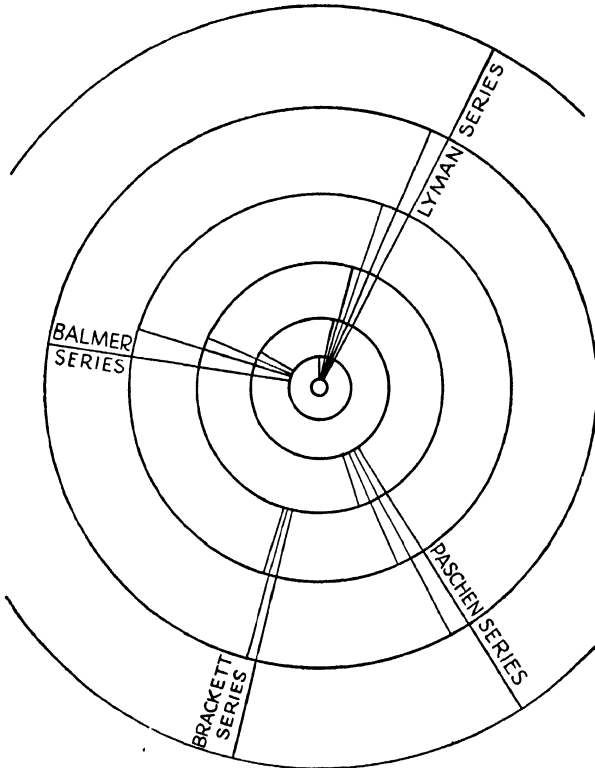

Fig. 27.—The Bohr model of the hydrogen atom.

The radii of the successive orbits are proportional to the squares of integers, i.e. to 1, 4, 9, 16, 25, 36, 49, etc. The various spectral series are indicated.

because work must be done to remove it from this level),

$-\frac{W}{4}$ when in the second orbit etc. Hence we speak of the

energies of the allowed orbits as being equal to $-\frac{W}{n^2}$, where

$n = 1, 2, 3, \dots$ The quantity, W , which depends upon the charge and mass of the electron and other constants, may be computed from Bohr's theory. A positive energy indicates that not only has the electron been removed from the atom but is flying away in space with a velocity of its own. One important point is that, although the negative energies are restricted by the condition $E = -\frac{W}{n^2}$, the positive energies are not restricted at all. This means, of course, that the electrons flying freely about in space are not constrained to move with special speeds but may travel about with random speeds and directions.

When an electron is removed from an atom, the atom is said to be *ionized*. To express the amount of energy necessary to tear an electron from the orbit of least energy entirely away from the atom we use a term called the *ionization potential*. This ionizing energy is measured in *electron volts*. The ionization potential of hydrogen is 13.54 volts, which means that if we accelerate an electron across a voltage potential drop of 13.54 volts it will possess just enough energy to detach completely the hydrogen electron from its orbit of least energy.*

Bohr postulated further that an electron may switch from an orbit of higher energy to one of lower energy. Since the transfer involves a loss of energy, Bohr supposed that the atom simultaneously releases a pulse or *quantum* of light and that the frequency and therefore the wave-length and color of the emitted radiation must be related to the difference in energy between the two orbits, viz:

* A neon sign glows because the electrons that constitute the electric current are speeded up across the large voltage drop in the tube. They acquire enough energy to collide with and excite the electrons in neon atoms to orbits of higher energy. As these atomic electrons drop again to lower orbits they radiate energy in the form of light.

$$\begin{aligned} \text{Energy radiated} &= [\text{Energy in larger orbit}] \\ &\quad - [\text{energy in smaller orbit}] \\ &= \text{a constant} \times \text{the frequency of emitted} \\ &\quad \text{radiation,} \end{aligned}$$

or

$$E_a - E_b = h\nu,$$

where E_a = energy when the electron is in the larger orbit,
 E_b = energy when electron is in smaller orbit,
 h = a numerical constant called *Planck's constant*,
 ν = frequency of the emitted radiation.

From these postulates Bohr was able to calculate the wave-length of the radiation resulting from any jump the electron might perform. We saw that the frequency of light is related to its wave-length by:

$$\text{frequency} = \frac{\text{velocity of light}}{\text{wave-length of light}}, \quad \text{or} \quad \nu = \frac{c}{\lambda}$$

and that by the Bohr theory the energy in the second orbit, for example, is $-\frac{W}{4}$ and in some higher orbit, say the fourth, the energy of the atom is $-\frac{W}{(4^2)} = -\frac{W}{16}$. The wave-length emitted by an atom when the electron "jumps" from the fourth to the second orbit should be given by

$$\frac{h\nu}{hc} = \frac{1}{\lambda} = \frac{W}{hc} \left[\frac{1}{2^2} - \frac{1}{4^2} \right] = R \left[\frac{1}{2^2} - \frac{1}{4^2} \right],$$

where we call the new constant $W/hc = R$. When the values of h , c and W as calculated from the Bohr theory are inserted, we obtain $\lambda = 4861\text{A} = 4.861 \times 10^{-5}$ cm., which is the wave-length of the blue hydrogen line! If we write down the formula for jumps or transitions from any orbit, the n th, say, to the second, we obtain

$$\frac{1}{\lambda} = R \left[\frac{1}{2^2} - \frac{1}{n^2} \right],$$

where $n = 3, 4, 5, \dots$ etc., which agrees exactly with the empirical formula for the wave-lengths of the Balmer series, including the numerical value of R . Similarly, all electron jumps terminating in the lowest orbit produce a series of lines in the far ultraviolet, the Lyman series, whose wave-lengths may be obtained from

$$\frac{1}{\lambda} = R \left(\frac{1}{1^2} - \frac{1}{n^2} \right),$$

where $n = 2, 3, 4, \dots$ and the constant R is exactly the same as before. The transitions ending in the third orbit give the infrared Paschen series and those ending on the fourth level the far infrared Brackett series.

We may conveniently represent the energies of the Bohr orbits by plotting them as horizontal lines or *energy levels*, as shown in Figure 28. Transitions between the various orbits are indicated in the figure by connecting vertical lines. A neutral hydrogen atom spends the vast majority of its time with the electron in its lowest orbit. In this condition, of course, the atom cannot radiate. When the electron is in one of the outer orbits, the atom is said to be *excited*. The electron may be driven into one of the outer orbits either by a collision with a rapidly moving atom or free electron, or by absorbing a quantum whose wave-length coincides with one of the lines of the Lyman series.

Once an electron arrives in a higher orbit, say the fifth, it may decide to jump to any one of the four lower orbits. But the decision must be made rapidly, for the electron lingers in an excited state only about a hundred-millionth of a second. A return to the lowest orbit will be accompanied by the emission of the fourth line of the Lyman series in the invisible ultraviolet. If the electron chooses to stop at the second level, the third line of the Balmer series, at 4340Å will be emitted and we shall have a minute flash

of violet light. Similarly, jumps from the fifth level to the third and fourth result in the second line of the Paschen series and the first member of the Brackett series, respectively, invisible infrared radiations.

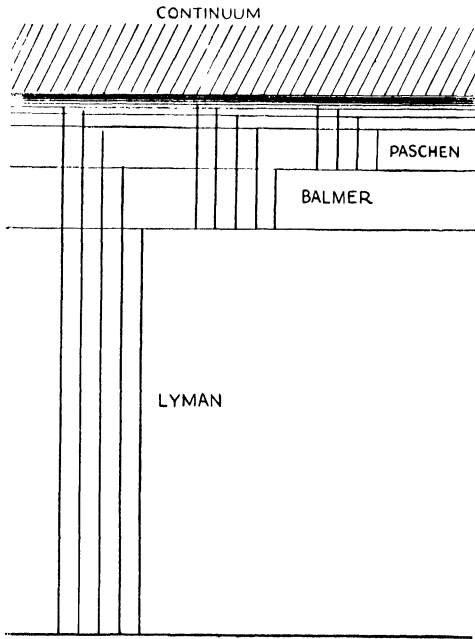

Fig. 28.—Energy level diagram for hydrogen.

In this figure we plot the energies instead of the orbits. Note that the two innermost orbits differ by the greatest amounts in energy. In the Bohr model, each level corresponds to an orbit, and the cross-hatched continuum corresponds to an electron completely detached from the nucleus or proton, and moving freely in space.

Figure 13 shows that the lines of the Balmer series crowd ever closer together toward the violet end of the spectrum until the lines terminate at the series limit, to be replaced by a continuous spectrum. Figure 28 serves to explain the coalescing of the lines near the series limit. As we go to

larger and larger orbits in the Bohr model, the difference in energy between successive orbits becomes less and less. The attraction between proton and electron diminishes, until ultimately a minute amount of energy is sufficient to detach the electron completely.

Referring again to our earlier discussion, on page 48, the zero of energy we chose there corresponds to the top of the series of horizontal lines in Figure 28. The shaded region above represents a positive energy, the energy of the proton and electron after the electron has been torn away. There are no longer any restrictions on the electron's speed; it may fly about in a carefree fashion although excessively high velocities are improbable. Now, we have seen that to produce a transition between any two of the Bohr orbits, or in terms of Figure 28, between the corresponding two levels (below the shaded region), a *discrete* amount of energy must be emitted or absorbed. This explains why the hydrogen lines appear only at certain wave-lengths and no others. But the electron may escape from the atom provided it absorbs *any* amount of energy above the minimum required for ionization. The excess energy is used up in imparting a velocity to the free electron. The upper portion of the shaded region in Figure 28 thus represents free electrons with high velocities, the lower portion those with low velocities. Consequently, the ionization of hydrogen atoms will produce a *continuous* absorption spectrum. Conversely, the *capture* of free electrons by protons produces a continuous emission spectrum at the violet end of the limit of each series. Figure 13 shows the continuous absorption at the limit of the Balmer series in a hot star.

COMPLEX ATOMS

We have discussed the spectrum of the simplest of all atoms, hydrogen. If we consider atoms with more than one

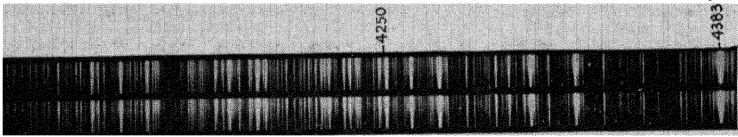

Fig. 29.—The spectrum of iron.

Photographed by Burns at the Allegheny Observatory.

electron, the problem becomes more involved. Each electron is free to travel in any one of a number of allowed orbits, as before. But the energy of the atom depends upon the particular combination of orbits that are occupied by its electrons. The greater the number of electrons, the more numerous will be the possible combinations of orbits, and therefore the greater the number of spectral lines. The spectrum of iron (Figure 29) is a good illustration of the intricacies of a complex atom. We find that a modified Bohr model is able to predict the exact number, but not the wave-lengths, of the spectral lines that are observed for each atom.

The intricacy of an atom's spectrum, however, is not always in direct ratio to the number of its electrons, for the following reasons. There are limitations on the number of electrons that are allowed to move in orbits at the same distance from the nucleus. In the hydrogen atom, the electron normally moves in the smallest orbit. If we go to helium, which has two electrons, we find that both of these play hide and seek about the nucleus in orbits of the same size. Lithium has three electrons; two of these cluster close to the nucleus, while the third moves in a larger orbit. Beryllium has four electrons, two in the inner and two in the more distant orbit. What happens with the electrons in boron, carbon, nitrogen, oxygen, fluorine, and neon? We find that their electrons, other than the first two, cluster in the second orbit until we reach neon. Then there are two

in the small orbit, and eight in the second orbit. We may speak of these sets of orbits as *shells* and say that the electrons tend to arrange themselves in shells about the nucleus. The first shell is completed at helium with two electrons, the second contains eight and is filled at neon with $2 + 8$ electrons. If n denotes the number of a shell, $2n^2$ represents the number of electrons it may contain. It develops that the electrons in a closed shell are very tightly bound to the nucleus, and are excited to higher orbits only at the expense of a considerable amount of energy. When all but one of the electrons in an atom are in closed shells, it is the motion of this outside electron that is responsible for the spectrum. In this event the spectrum is roughly similar to that of hydrogen.

The sodium atom with its eleven electrons falls into this hydrogen-like category. The outstanding feature of the sodium spectrum is a pair of strong lines in the yellow, the famous *D* lines in Fraunhofer's map of the solar spectrum. If we regard the two lines as a unit, the *D* lines form the first component of a series, the higher members of which are shown in Figure 14. Except for the doubling of the lines, this series closely resembles the Lyman series of hydrogen; the lines crowd closer and closer together and eventually approach a limit in the ultraviolet.

The doubling of each sodium line may be traced to the fact that the electron spins like a top at the same time that it revolves about the nucleus (see Figure 30). An electric charge, or electron, in motion is equivalent to a tiny electric current, which, as it flows in its closed circuit, generates a magnetic field. The revolution of the electron in its orbit about the nucleus generates one magnetic field, the spinning of the electron generates another. The energy of the atom depends upon the direction in which the electron is spinning. If, like the earth, the electron spins in the same sense as it

revolves, the energy will be greater; if the spin is in the opposite sense the energy will be less. Both directions of spin occur in sodium atoms. As a simple, although not rigorous, analogy we may compare the behavior of the

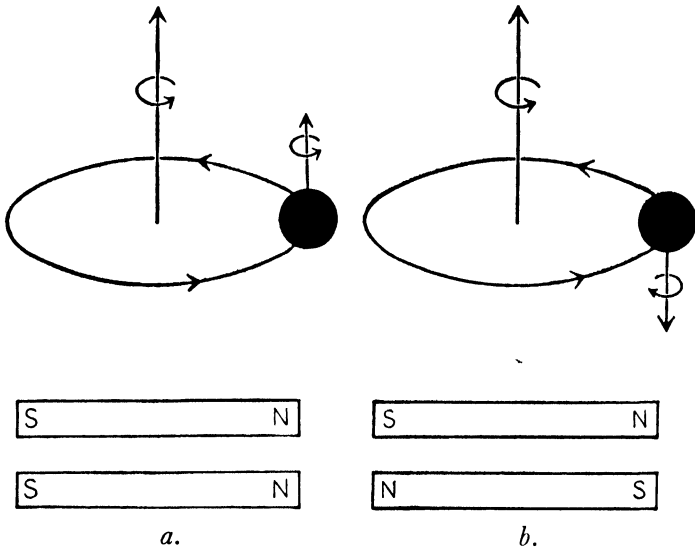

Fig. 30.—The magnetic effects of spinning electrons.

The curled arrows in the figure indicate the direction of revolution of the electron in its orbit and its direction of rotation. The straight arrows are also used to indicate angular motions in accordance with the right-hand rule, viz.; if the fingers of the right hand are curled in the direction of rotation, the thumb points in the direction of the arrow used to indicate motion of revolution or rotation.

spinning and revolving electron with two bar magnets. In one case (when the directions of spin and revolution are alike) the bar magnets are laid parallel, with their north poles side by side (Figure 30a); in the other the magnets are parallel, with the north pole of one next to the south pole of the other (Figure 30b). To shift the magnets from posi-

tion b to position a , we must exert energy in order to overcome the mutual attractions of the opposite poles and the repulsions of like poles. The two positions therefore represent different energies. In the same fashion, each orbit in the sodium atom has two energies, corresponding to the fact that there are two directions in which the electron may spin. Consequently, each line appears doubled. The effect of electron spin in hydrogen is very small and has not been observed in astronomical spectra. The hydrogen lines do, however, show a splitting which has been studied in the physical laboratory.

THE WAVE ATOM

During the past twenty years, the simple Bohr model has been replaced by a mathematical theory, which does not lend itself to pictorial visualization of the atom. The theory of the atom based on the laws of quantum mechanics shows that we cannot treat the electron as a *point* charge whose position in the atom at any instant may be strictly stated. Instead we may merely specify the likelihood or *probability* of finding the electron at any specified position. On this view the electron behaves for many purposes like a hazy cloud of electricity, as illustrated in Figure 31, where the photographs are the sort we might expect to obtain of hydrogen if the electron carried a tiny electric light and were photographed with a time exposure. There are many points of correspondence between the Bohr model and the wave model of quantum mechanics, one of them being that the electron is most likely to be found at the same distance from the nucleus as the Bohr theory predicts. Nevertheless the chance of finding the electron at some other distance from the nucleus may also be very good. The quantum-mechanical theory of the atom has enjoyed many successes, and seems likely to become a permanent fixture.

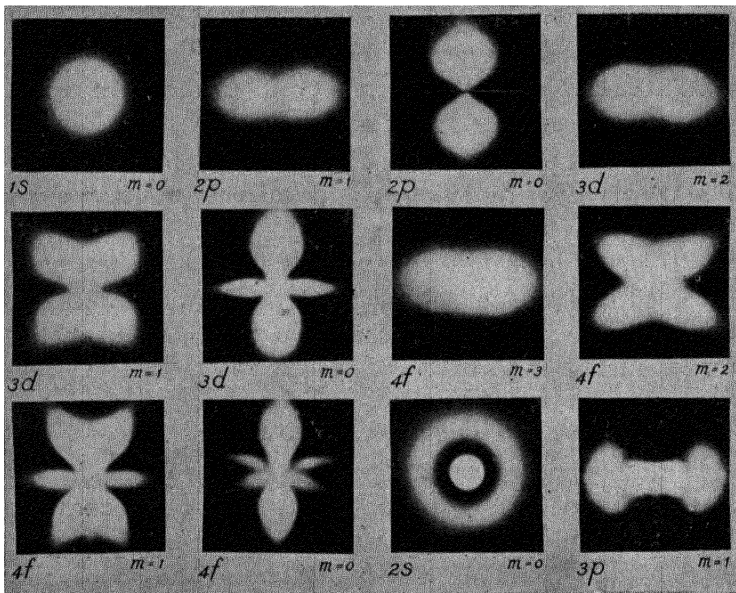

Fig. 31.—The wave model of the atom.

H. E. White made these photographs with the aid of a mechanical model; they are the pictures we might obtain if the electron carried a tiny electric light and were photographed with a time exposure.

In any event, whatever the model we use, we may always think of the atom as possessing a number of discrete states or levels of energy. The transfer of an atom from one state to another, by absorbing or releasing energy, gives rise either to an absorption or to an emission line as the case may be.

HOW ATOMS DISGUISE THEIR IDENTITIES

In Chapter 2 we made the statement that each of the ninety-two atoms known in nature was distinguished by a unique and characteristic set of spectral lines. The statement is not strictly true, however, for by losing one of its electrons an atom effectively disguises its identity and

radiates a completely new spectrum. E. C. Pickering, for example, examining the spectrum of Zeta Puppis in 1896, found a series of unidentified lines, something like the Balmer series of hydrogen, at wave-lengths 3814, 3858, 3923, 4026, 4200, and 4542A, and concluded that they were "due to some element not yet found on other stars or on the earth."

The problem was clarified in 1913 by Bohr, who showed, in connection with his theory of the hydrogen atom, that the spectrum emitted by ionized helium atoms would closely resemble that of hydrogen with the following important difference: The ionized helium lines in the visible portion of the spectrum correspond in origin to some of the infrared hydrogen lines. The energy of an electron in its orbit depends not only upon the number of the orbit but also upon the square of the nuclear charge. The charge of the helium nucleus is twice that of hydrogen. Consequently, each spectral series of hydrogen has its prototype in ionized helium, except that the wave-length of each helium line is one fourth that of the corresponding hydrogen line. The lines that Pickering found correspond to the long-wave infrared Brackett series of hydrogen, consisting of electron jumps terminating in the fourth level. By an interesting coincidence, alternate members of the Pickering series fall within two angstroms of the Balmer lines and were therefore missed by Pickering. In 1922 H. H. Plaskett reported the discovery of these helium lines in the spectra of three *O*-type stars. The prediction of Bohr, therefore, was brilliantly confirmed.

The similarity between the spectra of neutral hydrogen and ionized helium is one example of a general rule; the spectrum of an ionized atom is qualitatively similar to that of the neutral atom with the same number of electrons, but corresponding lines are displaced toward the ultraviolet.

The analogue of the H and K lines of ionized calcium is a pair of lines of neutral potassium in the red region of the spectrum.

MOLECULES AND THEIR SPECTRA

Complicated as is the spectrum of an atom like iron, its complexities fade into insignificance when compared with

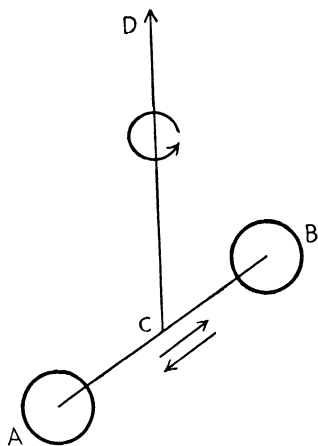

Fig. 32.—Schematic model of a simple diatomic molecule.

The arrows are to indicate that the molecule can rotate about the axis DC and vibrate back and forth along the line AB .

those of the spectrum of the simplest molecule. Like atoms, molecules can exist only in certain special energy states, and, like atoms, they emit light during the course of reverting from a state of higher energy to one of lower energy. But the energy states that are permitted a molecule are vastly more numerous and complicated than those of any atom.

We may liken a molecule consisting of two atoms to a dumbbell with a slightly elastic connecting rod (see Figure 32). The molecule may not only rotate bodily in space, but the two atoms may oscillate toward and away from one another. In addition, the electrons within each atom may pursue a modification of any one of the many orbits normally permitted them. At any instant, the total energy of the molecule will depend not only upon the energies of the revolving and spinning atomic electrons, but also upon the distance between the two atoms, and upon the speed of rotation of the molecule as a whole. Consequently, in place

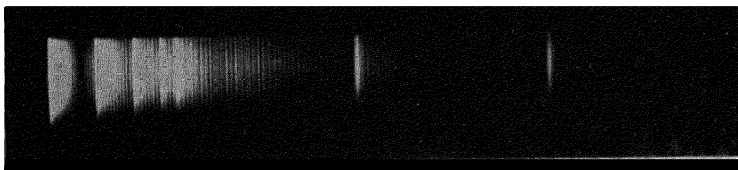

Fig. 33.—The spectrum of cyanogen, as photographed in the physical laboratory.

Note the individual lines that go to make up the bands. The overlapping of successive lines produces the phenomenon of band heads. (*Harvard Physics Laboratory.*)

of each atomic line, corresponding to a particular electron jump, the spectrum of a molecule contains a system of *bands*. Each band consists of a number of fine lines that converge slowly to a point known as the *band head*. The part of the spectrum where the whole set or system of bands falls depends on the change of electronic energy state in the molecule; the separations between the individual bands of a band system arise from changes of the vibrational states of the molecules while the separation of the individual fine lines within each band is due to differences in rotational velocities.

In Figure 33, the spectrum of cyanogen (CN) affords a beautiful example of the behavior of a typical diatomic molecule. All the bands in the figure and several others that are not seen in the photograph are analogous to one atomic line. We shall see later that molecules like cyanogen play an important role in the spectra of the cool stars.

With this brief description of the structure of atoms and molecules, we may proceed now to the story of how our knowledge of atoms and molecules, gained from laboratory and from theory, can aid in unravelling the mysteries of stellar atmospheres and nebulae.

4

THE CLIMATE IN A STELLAR ATMOSPHERE

*I*N THE PRECEDING TWO CHAPTERS WE SAW HOW MATTER hidden away in the far corners of the universe is forced to reveal its identity through the medium of the spectrum; we saw that the spectroscope can even clock the speeds of the stars and reveal their duplicities. But the story of its almost magical gifts of detection has barely begun. Indelibly recorded on every photograph of a stellar spectrum is a detailed account of the atmospheric conditions at the surface of a star. Strictly speaking, the spectrum tells us only which radiations the atoms are absorbing or emitting and how intensely. The atom, however, is a creature of climate; its ability to swallow up light depends upon the atmospheric conditions to which it is exposed. With our knowledge of atomic structure, we may now predict just what influence the stellar climate exerts on a particular atom, and thereby infer the stellar atmospheric conditions from the spectrum.

HOW HOT ARE THE STARS?

The most important attribute of stars, and indeed the one that makes it possible for us to see them at all, is high

temperature. The stars are so hot that their material cannot possibly exist in solid or liquid form; it must be entirely gaseous. We shall see that the effects of high temperature on the department of matter are often spectacular.

First of all we know that any temperature above the absolute zero* is always accompanied by the radiation of energy. Although radiation is insignificant at low temperatures, it becomes very important for hot bodies, because the total amount of energy radiated per square inch is proportional to the fourth power of the absolute temperature, a relation known as *Stefan's law*. For example, the average temperature of the earth is about 300°K . (absolute), or $\frac{1}{20}$ th that of the sun, which therefore radiates $(20)^4$, or 160,000 times more energy per unit surface area than the earth. We can measure the amount of radiant energy received on the earth from any star and if we also know the star's distance and its size, as is the case in certain eclipsing systems, we may calculate how much energy is leaving each square inch of the surface. This quantity in turn is related to the surface temperature by Stefan's law, and hence we have a method of finding the temperatures of stars whose distances and sizes are known. Eclipsing binaries (see Chapter 1) can provide us with information about the temperatures as well as the masses, sizes and densities of the stars. The relation between the diameter, temperature, and absolute brightness of a star is given in Appendix E.

Fortunately for our purposes, not only the amount, but also the quality, or color, of radiation is governed by the

* The lowest temperature that it is theoretically possible to attain is 273° below the Centigrade zero, the freezing point of water. Temperature reckoned from this point is expressed in "absolute" degrees by adding 273° to the centigrade value. Thus the freezing point of water is 273° absolute or Kelvin; 27°C . is 300°K .

temperature. Everyone is familiar with the way in which the lid of an overheated stove changes color as more fuel is added to the fire. At first the lid glows a dull red, then

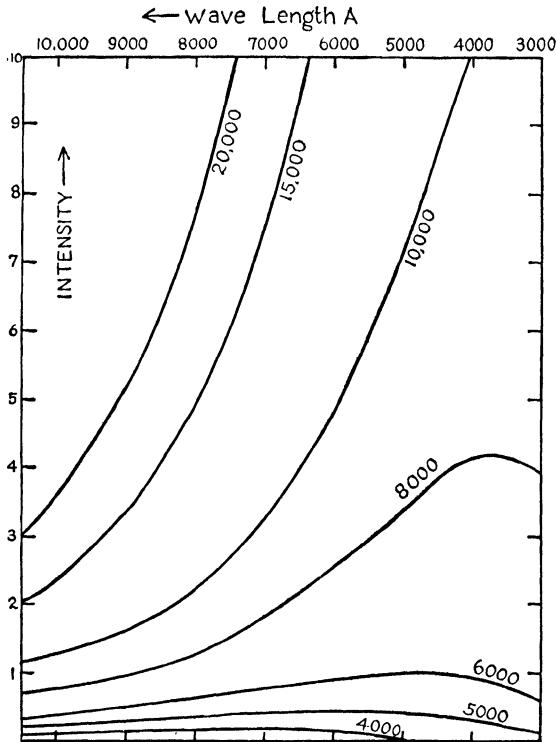

Fig. 34.—Energy emitted by a perfect radiator.

The curves give the relative energies radiated in the different wave-lengths for different temperatures. The range in wave-length 3000A to 10,000A is that over which the energy of a star can be measured. The temperature of each radiator, in degrees K., is shown with the appropriate curve.

turns a bright cherry color, and, if more and more coal is imprudently piled on, the color changes successively to orange, yellow, and white. This does not imply that only a single color is being emitted in each case, for we have

already seen that an incandescent solid radiates light of all colors. But the proportions of the different colors are altered as the temperature increases.

We obtain a better insight into what happens by studying, with the spectroscope, light sources of different temperatures. With the aid of a suitable energy-measuring device, we can determine how much energy is contributed by each color over a range of temperature from say 500°K . to $10,000^{\circ}\text{K}$. The curves of Figure 34 describe the variation of energy with color for different values of the temperature. Notice that the shape of the energy curve changes with the temperature; the wave-length of maximum energy radiation grows smaller with increasing temperature, which means that the light as a whole appears bluer. For this reason, the overheated stove lid appears to run the gamut of the spectrum as the temperature rises.

Spectral energy curves prove useful for evaluating the temperatures of the stars. From photographs of stellar spectra we measure the amount of energy radiated in each color and obtain an observed energy curve.* Although most stellar surfaces are hotter than any terrestrial source, energy curves for any value of the temperature may be calculated from theory and their shapes compared with

* The usual procedure is to photograph the spectra of a star and a standard lamp with the same arrangement of telescope and spectrograph. Some laboratory of physics such as the Bureau of Standards determines the true energy curve of the standard lamp, and a comparison of this true energy distribution with the one photographed through spectrograph and telescope yields the necessary information about the sensitivity of the plate and the transparency of the instrument to light of different colors. Spectrograms of the same star taken at various altitudes yield information about atmospheric transparency. These data enable the astronomer to compute the true energy distribution in a stellar spectrum from an observed stellar energy distribution. The variable transparency of the earth's atmosphere, especially in the ultraviolet,

the observed curve. An alternative method of temperature determination consists in ascertaining the color in which the star radiates the most energy. The sun (temperature $6000^{\circ}\text{K}.$) pours out the greatest amount of energy in the green region near 4800\AA . Altair, whose temperature is about $8530^{\circ}\text{K}.$ has a maximum near 3400\AA in the ultra-

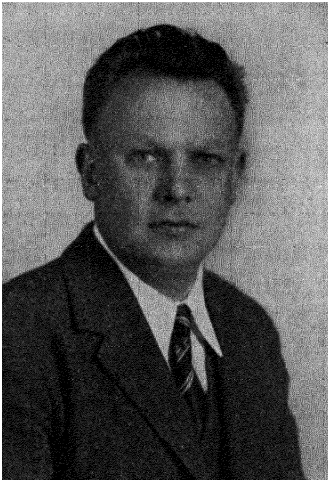

Fig. 35.—Gerard Peter Kuiper of the Yerkes Observatory.

violet. This latter method fails of course for the hotter stars whose energy maxima are in the astronomically inaccessible ultraviolet beyond 2900\AA .

THE RELATION BETWEEN THE TEMPERATURE AND SPECTRUM OF A STAR

Now that we may answer the question, "how hot are the stars?", we should like to know whether there is any connection between stellar temperatures and the spectral classes that were described in Chapter 2. We recall that,

purely on the basis of the appearance of the spectral lines, all stellar spectra could be arranged into one of the types; *O, B, A, F, G, K, M, N, R, S*. From the fact that *O* and *B* stars are blue in color, the *A* stars white, and the *G, K,* and *M* stars yellow, orange, and red, respectively, we might suspect that the classes have been arranged in order of decreasing temperature. Measures of stellar temperature

limits the accuracy of this method. In recent years, Kienle in Germany, Barbier and his colleagues in France, R. C. Williams at Michigan, and Davidson, Greaves, and Martin at Greenwich have measured the energy distribution in the spectra of the stars.

by the methods we have described reveal this view to be correct as the following table, due to Kuiper, indicates.*

TABLE 2
THE TEMPERATURES OF THE STARS (AFTER KUIPER)

<i>Star</i>	<i>Spectral class</i>	<i>Temperature</i>
Alpha Crucis	B1	23,000°
Spica	B2	20,400
Achernar	B5	15,500
Rigel	B8	12,300
Sirius	A0	10,700
Altair	A5	8,530
Procyon	F3	6,800

<i>Dwarf stars</i>			<i>Giant stars</i>		
Sun	<i>dG0</i>	6000°	Capella	<i>gG0</i>	5200°
σ Eridani A	<i>dG5</i>	5360		<i>gG5</i>	4620
ϵ Eridani	<i>dK0</i>	4910	Arcturus	<i>gK0</i>	4230
61 Cygni A	<i>dK5</i>	3900	Aldebaran	<i>gK5</i>	3580
Lacaille 9352	<i>dM2</i>	3200	Betelgeuse	<i>gM2</i>	3200

With the knowledge that each spectral class corresponds to a different temperature, we suspect that the weakness of the hydrogen lines in the *O* and *M* type stars, the former very hot, the latter cool, does not indicate a scarcity of that element; neither does the great number and intensity of iron lines in the spectrum of the sun necessarily point to an over-abundance of iron. A more reasonable view is that the behavior of atoms, i.e. their capacity for emitting and absorbing light, is regulated by the temperature. We shall

* The letters *d* and *g* before the spectral class indicate dwarf and giant, respectively. The significance of the division of the cooler stars into giant stars and dwarf stars will be discussed in the following chapter.

see in what follows that temperature alone can produce the transformation from a rich *M*-type spectrum to a comparatively bleak spectrum of type *B* (see Figure 23).

TEMPERATURE, RADIATION, AND ATOMS

Suppose that inside of a large box, made of some hypothetical unmeltable substance, we placed an assortment of all kinds of elements: hydrogen, helium, oxygen, nitrogen, sodium, calcium, iron, chromium, lead, etc. and that provision could be made for raising the temperature inside from the absolute zero to perhaps $50,000^{\circ}\text{K}$. What would happen to the elements as the enclosure grew hotter?

At the absolute zero all the matter is in the solid form; the individual atoms lie tightly packed, closely bound to one another in crystals or complicated molecular structures. The molecules are completely dormant, undisturbed by their neighbors or by any sort of radiant energy. As the temperature rises, the molecules begin to awaken from their lethargy and to stir about sluggishly, occasionally jostling one another. Soon the more volatile elements such as hydrogen, helium, oxygen, and nitrogen become liquid and then gaseous, driven by the ever increasing speeds of their molecules. As the temperature becomes yet greater, the elements liquefy and vaporize one by one. The pace becomes faster. Molecules dash madly about, careening into one another, and loading each other's electrons with energy, which is later lost in the form of radiation. Each molecule is assailed by flying particles and rapidly oscillating radiation waves. The molecules cannot long survive such brutal treatment. Eventually, one after the other is torn apart into the constituent atoms. Some molecules, like the hydroxyl radical OH , are tied together more tightly than others, and may survive long after their contemporaries vanish from the scene. But they too are eventually disrupted, leav-

ing only individual atoms with their electrons rapidly jumping back and forth between various excited levels, as each atom takes up energy from passing electrons and ions and passes it on as quanta of radiation. Some atoms, like hydrogen or helium, hold their electrons so tightly that only violent collisions or powerful pulses of energy are capable of raising the electron from its lowest orbit to a more distant one. Other atoms like sodium have only very loosely bound outer electrons and much gentler encounters or weaker pulses of energy are sufficient to excite them.

As the gas grows still hotter, collisions become increasingly violent, and the supply of high-frequency radiation increases. The atomic electrons are now so heavily battered that one or more of them may be torn completely free of the parent nucleus, i.e., the atom becomes ionized. In general, the metallic atoms sodium, iron, etc. are much more easily ionized than are the light gases, hydrogen, helium, oxygen, and nitrogen. The relative amounts of energy required to ionize several of the more abundant elements are listed in Table 3. Notice that helium is nearly twice as difficult to ionize as is hydrogen, which in turn is bound about twice as tightly as calcium.* This means that calcium, hydrogen, and helium tend to lose electrons at successively higher temperatures.

Thus far, in describing the influence of climate on the behavior of atoms, we have made no mention of the pressure, or density. Once an atom becomes ionized, it acquires a positive charge and does its best to retrieve electrons so that the charge will be neutralized. Whether or not the ionized atom has a good chance of succeeding in its quest depends upon the number of electrons in the vicinity, or,

* Atoms that are easily ionized are also more readily excited than those that are difficult to ionize.

in other words, upon the electron density. An atom, therefore, is more likely to radiate in the ionized condition when the density is low, and in the neutral form when the density is high.

The picture that we have drawn was first established on a quantitative basis by the Indian physicist, Megh Nad Saha, about twenty years ago. Saha not only showed that ionization would be favored by high temperature and low

TABLE 3a
THE IONIZATION POTENTIALS OF SOME ABUNDANT ELEMENTS

<i>Atom</i>	<i>Designation of the ion</i>		
	<i>I</i>	<i>II</i>	<i>III</i>
Hydrogen, H.....	13.530		
Helium, He.....	24.46	54.14	
Carbon, C.....	11.212	24.26	47.64
Nitrogen, N.....	14.46	29.44	47.20
Oxygen, O.....	13.55	34.94	54.63
Neon, Ne.....	21.47	40.91	63.3
Sodium, Na.....	5.11	47.06	71.30
Magnesium, Mg.....	7.61	14.96	79.74
Aluminum, Al.....	5.96	18.73	28.31
Silicon, Si.....	8.11	16.26	33.33
Sulphur, S.....	10.31	23.3	34.9
Argon, A.....	15.69	27.49	40.48
Potassium, K.....	4.32	31.67	45.5
Calcium, Ca.....	6.09	11.82	51.0
Titanium, Ti.....	6.81	13.6	27.6
Vanadium, V.....	6.72	14.1	29.6
Chromium, Cr.....	6.74	16.6	31
Manganese, Mn.....	7.41	15.56	34.4
Iron, Fe.....	7.83	16.16	30.48
Cobalt, Co.....	7.84	16.9	
Nickel, Ni.....	7.61	18.4	
Strontium, Sr.....	5.67	10.98	

TABLE 3b
THE IONIZATION POTENTIALS OF SOME IONS OF ASTROPHYSICAL
IMPORTANCE

<i>Ion</i>	<i>Ionization potential</i>	<i>Ion</i>	<i>Ionization potential</i>
CIV	64.17	SiIV	44.92
CV	390.12	SiV	165.66
CVI	487.55	SIV	47.08
NIV	77.04	SiV	63
NV	97.40	AlV	61
NVI	549.08	AV	78
NVII	663.73	FeVIII	150.43
OIV	77.03	FeIX	233.5
OV	113.30	FeX	261
OVI	137.42	FeXI	288.9
OVII	735.22	FeXV	454
NeIV	97		

Table 3a. The columns I, II, III refer respectively to the neutral, singly-ionized, and doubly-ionized atoms. For example, it takes 10.31 volts to ionize neutral sulphur, 22.3 volts to remove a second electron, and 34.9 volts to triply-ionize it. The symbol OI stands for neutral oxygen, NII for singly-ionized nitrogen and NeIII for doubly-ionized neon. Note that in general the metals are easy to ionize; it is far harder to ionize the permanent gases.

Table 3b lists the ionization potentials of several highly-ionized atoms. [After J. C. Boyce, *Rev. Mod. Physics* 13, 1 (1941).]

density, but was able to calculate exactly what fraction of atoms of a given kind would be ionized under specified conditions of temperature and pressure. His findings may be summarized by the formula:

$$\frac{(\text{number of ionized atoms})}{(\text{number of neutral atoms})} = \frac{(K, \text{ which depends on the kind of atom and the temperature})}{(\text{number of electrons})}$$

The degree of ionization of any atom thus depends directly on the temperature and is inversely proportional to the

number of free electrons.* A detailed discussion of the ionization formula and its application will be found in Appendix G.

THE MEANING OF THE SPECTRAL SEQUENCE

We now ask: What are the consequences of this change in the structure of matter from molecules to neutral atoms to ionized atoms, on the appearance of the spectrum at different temperatures? We have in a way already answered the question in Chapter 3. There we saw that the spectrum of a molecule, consisting of groups of closely-spaced fine lines which blend together to form broad bands, is totally unlike that of an individual atom. Also the spectrum of an ionized atom is similar to that of a neutral atom with the same number of electrons, except that each ionized line occurs much farther toward the ultraviolet than does the corresponding neutral line. This fact was illustrated by the similarity between the spectrum of hydrogen and that of ionized helium.

With these facts in mind we may now venture an interpretation of the spectra produced in stellar atmospheres. For the time being, we shall assume that all stellar atmospheres are of the same density, and consider only the effects of temperature. At a temperature of 2500° , large numbers of atoms are still joined as molecules. Combinations such as titanium oxide (TiO), cyanogen (CN), and the hydrocarbon molecule (CH) imprint their intricate band patterns on the continuous spectrum.† Of the elements that are present

* The Saha formula may also be employed to calculate the degree of disruption of molecules into atoms if the temperature is known. The number of neutral atoms is replaced by the number of molecules, and the numbers of ions and electrons by the numbers of the two constituent atoms into which the molecules are broken up.

† An abundant molecule, e.g. TiO in class *M* stars, may dominate the

as individual atoms, those that are easily excited—the metals like calcium, sodium, and iron—are prominently featured. Surprisingly enough, in spite of the relatively large quantities of energy necessary to excite them, atoms of hydrogen are also seen in the spectrum and with considerable strength. The appearance of hydrogen must be due

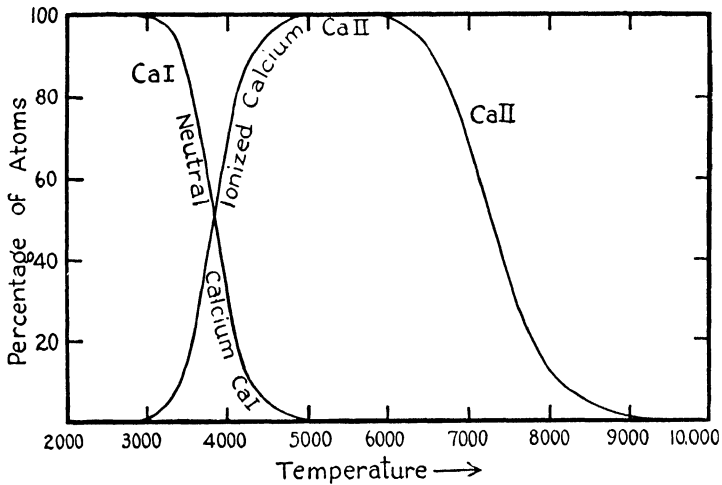

Fig. 36.—The ionization of calcium.

The curves show how the percentages of neutral and ionized calcium vary as the temperature rises. An electron pressure of 1/100,000 atmosphere has been assumed.

to its high abundance compared with other elements; in fact, as we shall see later, hydrogen accounts for about 80% of all the atoms in a star's outer envelope. Their great numbers compensate for the fact that, at low temperatures, only a small percentage are in a condition to absorb light.

entire spectrum. Figure 73 Chapter 7 shows a small region near $H\beta$ (λ 4861) in the spectrum of Mira Ceti. The individual lines of the band of TiO are well exhibited, although numerous background atomic lines in the spectrum of the star add further to the complicated appearance of the spectrum.

As the temperature rises along the spectral sequence, more and more molecules become disrupted. At class *K0*, the bands of titanium oxide have already vanished. Some of the more stubborn molecules, e.g. CN, CH, and OH persist as far as *G0*; they are easily recognized in the sun. Meanwhile, as increasing amounts of energy become available, the lines of hydrogen steadily strengthen. Even at low temperatures, some of the more loosely held electrons are broken off from their atoms as is shown by the appearance of the strong *H* and *K* lines of ionized calcium in even the low-temperature *M* stars. This pair of lines is strongest near *K0*, but from that point on, the calcium atoms begin to lose a second electron (see Figure 36); the *H* and *K* lines weaken and fade away entirely at temperatures greater than $10,000^\circ$. They are still dominant, however, in class *G*, as are the lines of neutral iron, magnesium and other metals, and the ever growing hydrogen lines.

In class *F*, at a temperature of about 6500° , other metallic atoms appreciably part with their electrons; neutral iron and titanium weaken markedly, ionized iron and ionized titanium attain prominence until deprived of still a second electron, and then vanish as the temperature climbs beyond $10,000^\circ$. At class *A0*, hydrogen attains its greatest glory, completely overshadowing all other atoms. But the inexorable march of temperature soon strips great numbers of hydrogen atoms of their single electrons, without which they are impervious to radiation, and their lines begin to fade. Here again, however, at the upper end of the temperature scale, hydrogen remains visible through sheer weight of numbers of atoms.

The very hot stars, in classes *B* and *O*, range in surface temperature from about $15,000^\circ$ to perhaps more than $50,000^\circ$. The advent of high temperature is signaled by the appearance, in class *B9*, of neutral helium, the most difficult

to excite of all the neutral atoms. The helium imprints acquire their greatest intensity in class *B3*, and then rapidly weaken as the atoms become more and more ionized. The spectra of the *B* stars exhibit also singly-ionized oxygen and nitrogen.

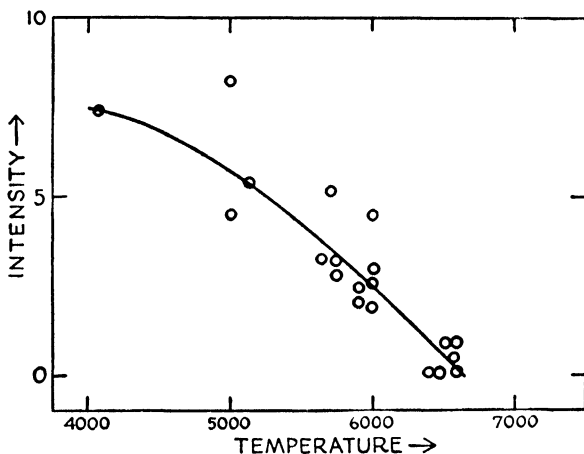

Fig. 37.—The observed intensity variation of the 3709 iron line.

Eye estimates of intensity on an arbitrary scale are plotted against temperature. Notice how the intensity decreases, as the temperature rises, due to the ionization of iron. Zero intensity refers to a line which is barely visible on the plates used.

In the very hottest stars of class *O*, hydrogen is about as conspicuous as in class *M*. Under the strenuous conditions prevailing, neutral helium disappears completely, giving way to its ionized form. The spectral lines of elements that are stripped of more than one electron are mostly hidden in the inaccessible* far ultraviolet part of the spectrum, but in class *O* we find doubly-ionized oxygen and nitrogen, and triply-ionized silicon.

* Light of wave-length shorter than 2900Å is completely blacked out by the absorption of ozone and other gases in the earth's atmosphere.

The practical classification of stellar spectra begins with type *O5* rather than *O0*, in order to leave a place for still hotter stars that may be discovered later. Theoretically, at temperatures near $100,000^{\circ}$, all lines in the observable region of the spectrum should disappear, although the short wave-length region from 100 to 2000\AA would be rich in



Fig. 38.—Cecilia H. Payne-Gaposchkin of Harvard.

lines of multiply-ionized atoms. A star so hot as to show no spectral lines would be placed in class *O0*.

We have been making the tacit assumption in our discussion that all stellar atmospheres possess the same chemical compositions, for, obviously, an element that is not present at all in an atmosphere will be absent from the spectrum. The intensities of an atom's spectral lines will depend upon its abundance as well as on the temperature and pressure, for large numbers of atoms will absorb more radiation than just a few. Theoretical calculations show our assumption to be correct. Suppose, for example, that we have calculated the chemical composition of the solar atmosphere (by

methods that we shall describe later). If we now take a hypothetical star, and, with the aid of Saha's formula, predict its spectrum at different temperatures from 2500° to $50,000^{\circ}$, we find that we can reproduce the observed features of the spectral sequence if, and only if, we adopt the same mixture of elements as in the sun. Other assumed mixtures would lead to quite different sets of spectra. To be sure, there seem to be a few freaks that are overstocked with one element or another, but at least 95% of the stars whose spectra have been photographed appear to contain the same elements, in the same relative proportions, as in the solar atmosphere. This result was established some fifteen years ago by the thorough studies of Mrs. Payne-Gaposchkin.

In our interpretation of the spectral sequence, we have assumed, for simplicity, that all stellar atmospheres are of equal density. For a great many stars this assumption is correct, but it fails entirely for many others. In the next chapter we shall see just what effect the density exerts on the appearance of stellar spectra, and how we may turn this effect to good advantage in deducing the size and intrinsic luminosity of a star from its spectrum.

5

DWARFS, GIANTS, AND SUPERGIANTS

*T*HE TOTAL AMOUNT OF RADIATION FLOWING FROM THE surface of a star, i.e., its intrinsic luminosity, is measured by its absolute magnitude, which, as we recall from Chapter 1, is the apparent magnitude the star would have if placed at a distance of 10 parsecs, or 32.6 light years. Since the energy radiated per unit area depends only upon the surface temperature, we would expect two stars of roughly the same size and temperature to be of the same absolute magnitude. All stars are, however, not uniform in diameter; they vary from diminutive objects one-fiftieth the diameter of the sun to mammoth spheres a thousand times larger. The great disparity in stellar sizes and brightnesses may be illustrated by a diagram of the sort known as the Russell-Hertzsprung diagram, in which the spectral types, which depend on temperature, are plotted against the absolute magnitudes, which measure the luminosity (see Figure 39). Notice that the great majority of points fall in a narrow belt running diagonally downward across the diagram. The intrinsically bright stars lie high in the diagram, the faint ones low. The

stars in the diagonal belt are said to belong to the *main sequence*. In this region, the luminosity is correlated with spectral class in the sense that the more luminous stars are the hotter and bluer.

Of special interest are the exceptionally luminous stars that lie above the main sequence, and the unusually faint

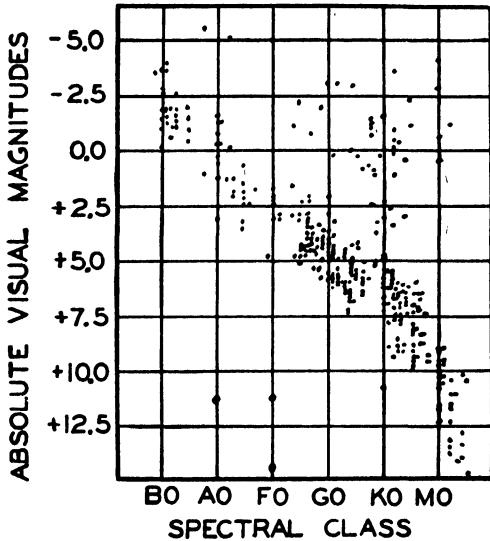

Fig. 39.—The Russell-Hertzsprung diagram.

(Reproduced from *The Telescope*.)

ones that fall below it. To the stars of high luminosity Hertzsprung applied the designation *giants*, as distinguished from the fainter ones, which he called *dwarfs*. Certain of the very brightest stars, such as Antares, Canopus and Rigel, which are far more brilliant than even the giants, are known as *supergiants*. The dimly shining whitish stars of classes *A* and *F* are the so-called *white dwarfs*.

The terms giant and dwarf were originally used by Hertzsprung to describe the relative *brightnesses* of the two classes

TABLE 4
 MASSES AND DIMENSIONS OF SOME ECLIPSING DOUBLE STARS
 (From J. H. Moore, "Fourth Catalogue of Spectroscopic Binary Stars")

<i>Star</i>	<i>Spectrum</i>	<i>Period</i>	<i>Radius</i>	<i>Mass</i>	<i>Density</i>	<i>Separation</i>
<i>AG Per</i>	<i>B3k</i>	2 ^d 03	3.75	5.18	0.10	14.26
			2.62	4.57	0.25	
<i>β Aur</i>	<i>A0p</i>	3.96	2.81	2.40	0.11	17.7
	<i>A0p</i>	...	2.81	2.36	0.11	
<i>TY Gem (Castor C)</i>	<i>M1e</i>	0.81	0.76	0.63	1.4	3.88
			0.68	0.57	1.8	
<i>W UMa</i>	<i>F8p</i>	0.33	0.89	0.75	1.96	2.19
	<i>F8p</i>	0.72	0.54	3.33	
<i>RS CVn</i>	<i>F4n</i>	4.80	1.6	1.88	0.45	18.4
	<i>dG8</i>	5.4	1.74	0.012	
<i>U Oph</i>	<i>B5nk</i>	1.68	3.23	5.36	0.18	12.8
	<i>B5nk</i>	3.23	4.71	0.16	
<i>u Her</i>	<i>B3</i>	2.05	4.64	7.3	0.094	14.6
	<i>B3</i>	4.64	2.8	0.036	
<i>U Sge</i>	<i>B9n</i>	3.38	3.4	6.80	0.171	19.59
	<i>gG2</i>	5.7	2.03	0.011	
<i>σ Aql</i>	<i>B3</i>	1.95	3.56	6.19	0.15	14.69
	<i>B3</i>	3.56	5.14	0.12	
<i>Y Cyg</i>	<i>O9nnk</i>	3.00	5.86	17.1	0.085	28.44
	<i>O9nnk</i>	5.86	17.3	0.086	
<i>RT Lac</i>	<i>G9</i>	5.07	5.0	1.0	0.01	17.90
	<i>K1</i>	5.0	1.9	0.02	
<i>AR Lac</i>	<i>G5</i>	1.98	1.88	1.42	0.214	9.39
	<i>K0</i>	3.10	1.41	0.047	

TABLE 4a

<i>β Persei (Algol)</i>	<i>B8</i>	2 ^d 07	3.12	4.72	0.16	15.1
	<i>G4(?)</i>	3.68	0.95	0.02	
<i>V 380 Cygni</i>	<i>B2</i>	12.43	29	43.7	0.002	88
			8	15.6	0.027	
<i>ζ Aurigae</i>	<i>K5</i>	972 ^d	300	20	0.74 × 10 ⁻⁶	1240
	<i>B</i>	5	9	0.08	
<i>VV Cephei</i>	<i>M2</i>	7430 ^d	1220	47	3 × 10 ⁻⁸	7100
	<i>B9</i>	33	

The radii, masses and densities are given in terms of the sun; the separation of the two stars of the binary is expressed in terms of a solar radius as unit. The radius of the sun is 6.953 × 10¹⁰ cm. (432,000 miles), the mass of the sun is 1.983 × 10³³ grams (332,000 times the mass of the earth), and the density of the sun is 1.41 that of water. The data for Algol are from McLaughlin, those for V 380 Cygni from Kopal, those for VV Cephei from Goedicke, while the results for Zeta Aurigae are taken largely from the studies of Hopmann and Schaub.

TABLE 5
 MASSES, TOTAL LUMINOSITIES, RADII, DENSITIES, AND SURFACE GRAVITIES
 OF SOME DWARF STARS
 (From a Compilation by G. P. Kuiper)

<i>Star</i>	<i>Mass</i>	<i>Lumi- nosity</i>	<i>Radius</i>	<i>Density</i>	<i>Surface gravity</i>
η Cas, <i>A</i>	0.72	0.81	0.81	1.32	30
<i>B</i>	0.47	0.07	0.56	2.55	41
σ_2 Eri, <i>B</i>	0.44	0.0055	0.018	0.7×10^5	37,000
<i>C</i>	0.20	0.011	0.43	2.54	31
α CMa, <i>A</i>	2.35	39	1.8	0.42	28
<i>B</i>	0.98	0.0026	0.022	0.85×10^5	53,000
α CMi, <i>A</i>	1.48	5.75	1.7	0.31	15
ζ UMa, <i>A</i>	2.6	30	1.9	0.37	20
α Cen, <i>A</i>	1.1	1.25	1.23	0.60	20
<i>B</i>	0.87	0.37	0.87	1.32	33
ξ Boo, <i>A</i>	0.87	0.48	0.87	1.25	32
<i>B</i>	0.76	0.15	0.79	1.56	34
ζ Herc, <i>A</i>	0.95	3.9	1.95	0.13	7
μ Herc, <i>BC</i>	0.44	0.043	0.80	0.93	20
70 Oph, <i>A</i>	0.89	0.42	0.93	1.13	30
<i>B</i>	0.74	0.14	0.69	2.2	43
Krueger 60, <i>A</i>	0.25	0.017	0.51	1.85	26

Mass, luminosity, radius, and density are expressed in terms of the sun as 1.0. The luminosities are bolometric rather than visual. Surface gravity is given in terms of the surface gravity at the surface of the earth.

of stars, but we have since learned that they also differ widely in other physical characteristics. In the first place, sufficient numbers of the two types of stars are found in double-star systems so that we may form a representative idea of their masses. Also, from the temperature, and therefore from the amount of energy radiated by each unit area of the stellar surface, we may calculate how large each star must be to have its observed luminosity. Then, from the mass and volume, we find the average density.

Tables 4, 5 and 6 list the spectra, distances, sizes, masses and luminosities of a number of dwarf, giant and supergiant stars for which reliable data are available. In Table 4 we give the data for a number of eclipsing stars with two spectra visible and for which the radii, separations, masses and densities may be determined. Table 4a summarizes

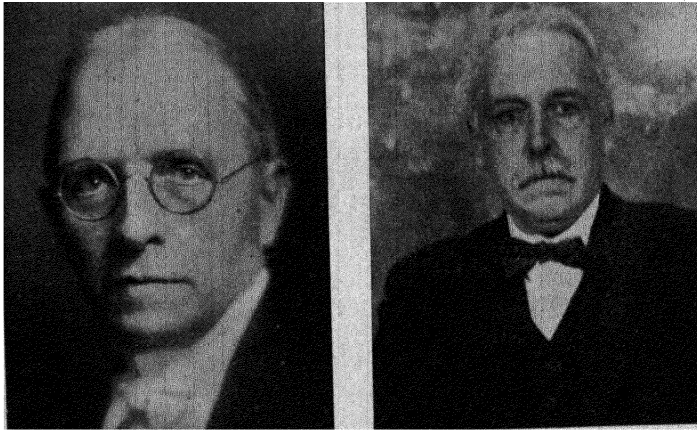

Fig. 40.—Henry Norris Russell of Princeton.

(Photograph by Harris and Ewing).

Fig. 41.—Ejnar Hertzsprung of Leiden.

the material for some interesting eclipsing binaries such as Zeta Aurigae and *VV* Cephei. Table 5, based on a compilation by Kuiper, gives the masses, total or bolometric luminosities, and radii in terms of the corresponding quantities for the sun. The densities are given in terms of that of the sun and the surface gravity in terms of the surface gravity at the surface of the earth. Table 6 gives the dimensions of certain giant and supergiant stars whose angular diameters in seconds of arc, except for Capella, have actually been measured by Pease with an instrument called the *interferometer*.

The variation in radius is relatively small along the main sequence (see Figure 42a). The supergiant Antares, however, is about three hundred times as large as the sun. On the other hand, one or two of the white dwarfs are no bigger than the earth! Large stars tend also to be massive, but the range in stellar masses does not begin to approach

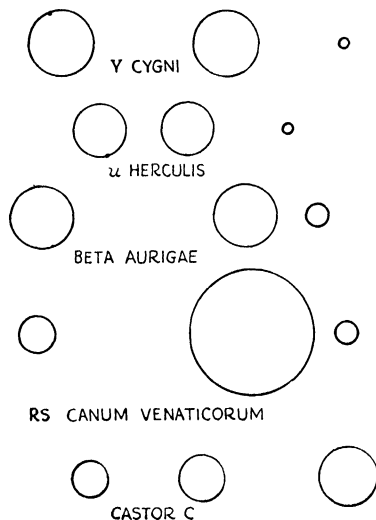

Fig. 42a.—The dimensions of main-sequence stars.

Sizes and separations of some of the eclipsing binaries listed in Table 4 are plotted to scale. The sun is represented by the circles at the extreme right.

the range in sizes. Consequently, the stars display a startling variety of densities. The average density of the sun, for example, is somewhat greater than that of water—about equal to that of soft lignite coal. The radius of the supergiant Antares is about 330 times, and its volume about $(330)^3$, or 36,000,000 times, that of the sun. But Antares probably weighs only thirty times as much as the sun, and hence its density is on the average less than a millionth that of the sun.

On the other hand, although the white dwarf α Eridani B has only six millionths the solar volume, its mass is about 45% that of the sun, which gives the star the amazing density of about 100,000 times that of water, or nearly two tons to the cubic inch. The white dwarf known as “van

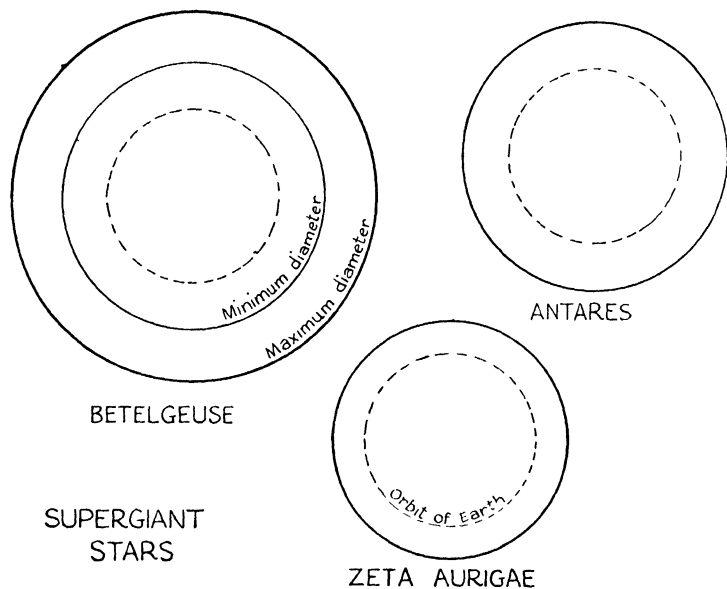

Fig. 42b.—Supergiant stars.

The dotted circle indicates the size of the earth's orbit, whose radius is 93,000,000 miles. Betelgeuse is an irregular variable in both light and dimensions.

Maanen's star" has about three ten-millionths the solar volume and a density that may be as high as seven tons per cubic inch. We shall discuss this remarkable result later in connection with the evolution of the stars.

A number of the dwarf binaries in Table 5 are of special interest. Alpha Centauri, which is the nearest star (excluding the sun!), consists of two stars of nearly the same

mass as the sun, plus a small distant companion one fifteen-thousandth as bright as the sun. Krueger 60B is the faintest star whose mass is known. The even fainter star Wolf 359 is unfortunately a single star and therefore cannot be weighed. A planet would have to be at a distance of half

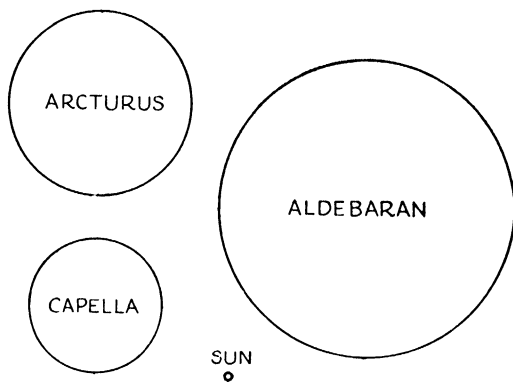

Fig. 42c. — Some typical giant stars.

Capella is a spectroscopic binary whose spectrum is similar to that of the sun. Pease measured the actual angular diameters of Aldebaran and Arcturus with the Michelson interferometer. Since the distances of these stars are known to a fair degree of accuracy, their linear dimensions may be computed.

a million miles from Wolf 359, or about twice the distance of the moon from the earth, in order to receive as much light as the earth gets from the sun. If, however, either of the two stars Arcturus or Aldebaran were to replace the sun, we should be comfortable at the present distance of Saturn (886,000,000 miles). With Betelgeuse as our central luminary, twice the distance of Neptune from the sun would be a good place for our abode. From this vantage point, Betelgeuse would appear forty times larger in the sky than does our present sun, but because of Betelgeuse's low temperature its apparent total brightness would equal that of our sun.

TABLE 6
THE DIMENSIONS OF SOME GIANT AND SUPERGIANT STARS

<i>Star</i>	<i>Spectrum</i>	<i>Distance</i> (<i>light</i> <i>years</i>)	<i>Diameter</i> (<i>sun</i> = 1)	<i>Luminosity</i> (<i>sun</i> = 1)
α Aurigae (Capella)	G0	42	16	150
α Bootis (Arcturus)	K0	33	22	83
α Tauri (Aldebaran)	K5	53	35	91
α Orionis (Betelgeuse)	M2	300	460-330	3600
α Scorpii (Antares)	M1	250	330	1900
β Pegasi (Scheat)	M5	160	113	170
α Herculis (Ras Algethi)	M8	800	800	1900
\circ Ceti (Mira)	M7e	250	460	180 (max)

THE SPECTRA OF GIANTS AND DWARFS

In 1914, W. S. Adams and A. Kohlschütter, working at

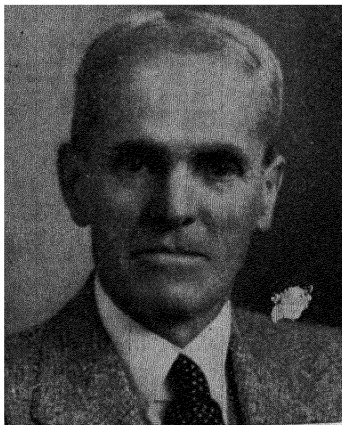

Fig. 43.—Walter S. Adams of Mount Wilson.

the Mount Wilson Observatory, made the remarkable discovery that the intrinsic brightness of a star could be learned from its spectrum. Closely scrutinizing the spectra of giants and dwarfs of the same spectral type, they found that the two groups of spectra were not exactly alike, as membership in the same spectral class would imply. Compare, for example, the two spectra shown in Figure 45, belonging to two stars of the same spectral class. One of the stars, the sun, is a dwarf; the other, Zeta Capricorni, is a

supergiant. The general features of both spectra match one another almost perfectly, with one marked exception. The two lines of ionized strontium, although barely visible in the sun, are extremely intense in Zeta Capricorni, whose luminosity is 6000 times that of the sun. Also, in Figure 46, we compare the spectrum of the supergiant star Betelgeuse with that of the dwarf Lalande 21185, both of class *M2*. Again we notice that one spectrum is almost the exact counterpart of the other, except for small details. Particularly conspicuous is the enormous intensity of the neutral calcium line at 4227Å in the spectrum of the dwarf, and

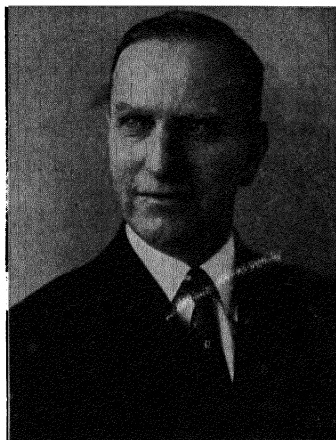

Fig. 44.—Arnold Kohlschütter of Bonn.

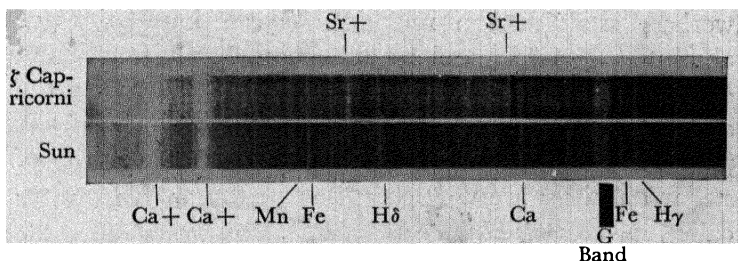

Fig. 45.—Spectra of the sun and Zeta Capricorni.

The *G*-type supergiant shows much stronger lines of ionized strontium than the sun. The diameter of Zeta Capricorni is about 80 times that of the sun. (After W. W. Morgan, Yerkes Observatory.)

its feebleness in the supergiant, which is 300,000 times more luminous. Figures 45 and 46 are two illustrations of a

general rule found by Adams and Kohlschütter, namely, that certain ionized lines tend to be strong in giant stars and weak in dwarfs, and that certain neutral lines behave in the opposite sense. The ratio of intensity of the 4215 line of ionized strontium to the 4260 line of neutral iron provides a sensitive criterion of absolute magnitude. By estimating the relative intensities of these lines in the spectra of nearby stars, i.e., stars whose distances could be determined by the surveyor's method (see Chapter 1), the Mount Wilson

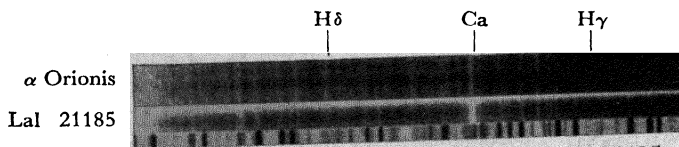

Fig. 46.—The spectrum of α Orionis and Lalande 21185.

The hydrogen lines are much stronger in the $M2$ supergiant α Orionis while they are almost missing from the $M2$ dwarf which shows intense λ 4227 of calcium. Betelgeuse or α Orionis has a diameter 400 times that of the sun, Lalande 21185 is half the size of the sun. The bands of titanium oxide, so characteristic of M -type spectra, are not located in the spectral region illustrated. (After W. W. Morgan, Yerkes Observatory.)

workers established a relation between luminosity (or absolute magnitude) and spectral line intensity (see Figure 47). This relation was then employed in determining the absolute magnitudes of distant stars, for which direct parallax measures were impossible. The great majority of stellar distances are now estimated in this way, from so-called *spectroscopic absolute magnitudes*.

The discovery of Adams and Kohlschütter can easily be explained in terms of the different physical conditions that prevail in the atmospheres of giant and dwarf stars. The chief difference is one of density. Tables 4 and 5 show that the stellar material of the intrinsically faint dwarfs is relatively closely packed, and that the bright stars are very much more tenuous. The densities that we have given

are, of course, average values for the whole body of each star, but the dense dwarfs may also be expected to have shallow, compressed atmospheres, and the tenuous giants rarefied and extended ones. In other words, the density of a star's

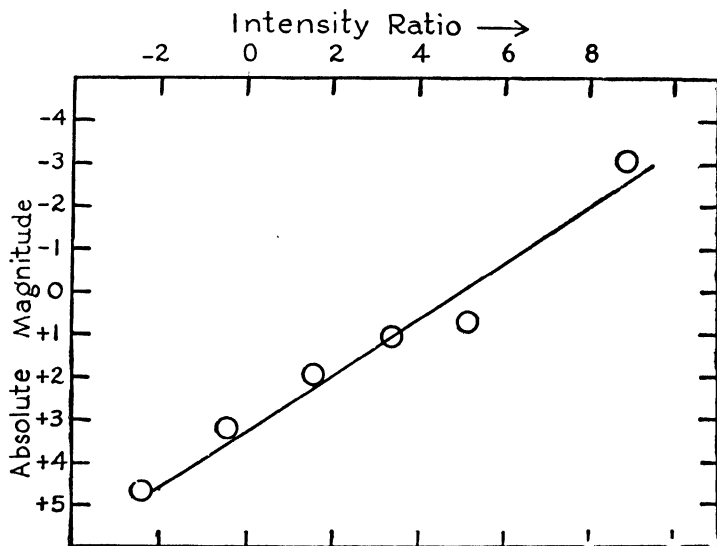

Fig. 47.—Intensity ratio of the ionized strontium 4215 line to the neutral iron 4260 line.

The intensity ratio 4215/4260 is plotted against absolute magnitude. The ordinate zero corresponds to equal intensities of the two lines. (*A.J.C.R. D. Hoffleit, Harvard Observatory.*)

atmosphere appears to be correlated with its size and luminosity.

We recall from Chapter 4 that the density has an important influence on the appearance of the spectrum. When the density is low, and free electrons are few and far between, atoms are more easily maintained in the ionized condition than at high densities. Consider, for example, the behavior of an element such as calcium, which exists in both the

neutral and ionized forms in a great many stars. Neutral calcium atoms absorb a spectral line in the blue-violet region at 4227A; ionized calcium produces the well-known *H* and *K* lines in the far violet. Given two stars of the same temperature, one a tenuous giant and the other a dense dwarf, we would expect a greater percentage of calcium atoms to be ionized in the giant. Consequently, the neutral line should be weak in the giant and strong in the dwarf, whereas the converse should hold true for the ionized lines. This is precisely the effect illustrated in Figures 45 and 46.

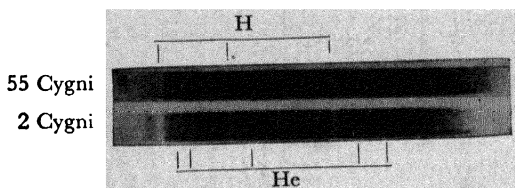

Fig. 48.—Hydrogen lines in a supergiant and a main-sequence or dwarf star.

Notice that the hydrogen lines are considerably weaker in the *B*-type supergiant than in the dwarf 2 Cygni. The diameter of 55 Cygni is about 50 times that of the sun; that of 2 Cygni is about 5 times the sun's diameter. (After W. W. Morgan, Yerkes Observatory.)

Now in practice we do not compare the spectra of two stars of the same temperature, but rather two stars of the same spectral appearance. The spectral type is judged from the intensities of the spectral lines and not from the intensity distribution in the continuous background. A given spectral type corresponds therefore to a certain degree of average ionization. High temperature as well as low density favors ionization; a dwarf star is hotter than a giant of the same spectral class, the higher temperature of the dwarf compensating for the lower density of the giant. If this compensation were identical for all elements, the spectroscopic discrimination between giants and dwarfs would be

virtually impossible. Fortunately this is not the case, and, for some elements such as strontium, the ionization is more sensitive to low density than to high temperature. Hence the ionized strontium lines are strong in giants but weak in dwarfs of the same spectral class. Calcium is another example. The ionization of calcium is more sensitive to the low densities of the atmospheres of giants than to the higher temperatures in the atmospheres of dwarfs. Hence the line of neutral calcium at 4227A is stronger in dwarfs than in giants of the same spectral class (see Figure 46).

THE WIDTHS OF SPECTRAL LINES

In addition to variations in the strengths of neutral and ionized lines in the spectra of giants and dwarfs, there is a pronounced tendency for a majority of spectral lines to appear broad and fuzzy in the dwarfs and narrow and sharp in the giants. A good example of this characteristic is shown in Figure 48, where the spectrum of the supergiant 55 Cygni is compared with that of the much smaller star 2 Cygni. There are many reasons why spectral lines appear broad. In the first place, the sharpness of the lines is limited by the fact that the slit of the spectroscope is not infinitely narrow, but possesses a very definite width. But even if we could observe the radiation from a single atom through an infinitely narrow spectroscope slit, the line would still appear to have a finite width. In other words, the atom does not radiate solely at a single wave-length, but may also radiate (or absorb) energy at adjoining wave-lengths. The line is said to possess a *natural width*, as shown in Figure 49, in which intensity is plotted against distance from the line center. Notice that most of the radiation is confined close to the center of the line.

We may, if we like, visualize the atom as a tiny broadcasting station, and the spectroscope as a radio receiver.

The station is usually assigned a specific broadcasting wave-length, but due to natural limitations on the broadcasting equipment, the wave-length of the signal is not perfectly sharp. There is one place on the dial where the reception is loudest, but the program may also be received, although

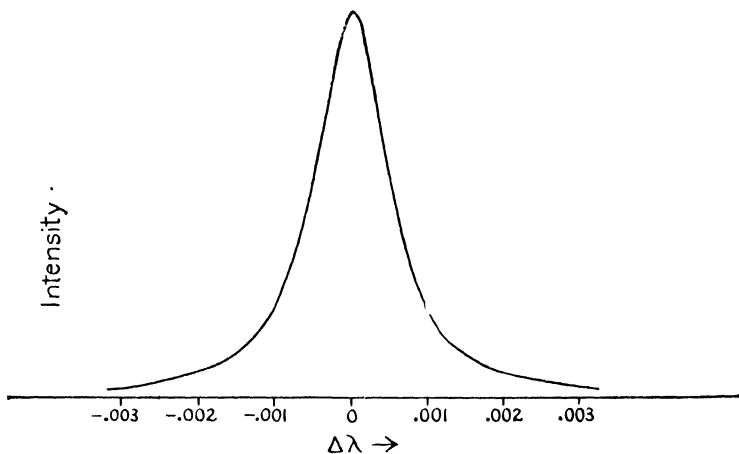

Fig. 49.—The natural breadth of a spectral line (λ 4383 of iron)

If we could observe the radiation from atoms at the absolute zero (a condition we might approach experimentally by cooling the discharge tube with liquid helium), emission lines might look like this. Intensity of the emitted radiation is plotted against wave-length distance from the center of the line. Since capacity to emit is proportional to the absorptivity, this curve also shows how the absorptivity varies in different parts of a spectral line.

less distinctly, at neighboring wave-lengths on either side of the assigned wave-length.

Another important factor in line broadening is the Doppler effect. We recall from Chapter 2 that the wave-length of the light emitted or absorbed by a source that is in motion along the line of sight is displaced from the normal position by an amount proportional to the speed of approach or recession. The spectral lines of an approach-

ing star are shifted toward the violet, those of a receding star toward the red end of the spectrum. The individual atoms in the atmosphere of a star are not at rest, but are flying about with different velocities (see Figure 50). Some atoms are approaching the observer at the instant

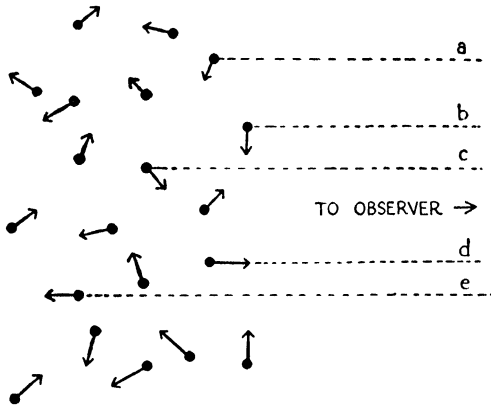

Fig. 50a.—The random motions of radiating atoms.

Radiation from atoms *a* and *e* is shifted towards the red, while that from *c* and *d* is shifted violetward. The wave-length of the radiation from *b* is unchanged. In Figure 50*b* the letters *a*, *b*, *c*, *d*, and *e* refer to the wave-lengths emitted by the corresponding atoms in 50*a*.

they radiate; others are receding. Radiation emitted by approaching atoms will be of higher frequency than normal; radiation emitted by receding atoms will have a lower frequency than normal. The velocities should be entirely at random as far as directions are concerned and since an observed spectral line is the sum of the contributions from a great number of individual radiating atoms, the spectrum line will appear widened. The degree of blurring of a line depends on the velocities of the particles; thus hydrogen atoms move faster on the average than other atoms and hydrogen lines are widened more than those from heavier

elements. At higher temperatures also, the blurring is exaggerated because the atoms are moving more rapidly and the Doppler displacements are hence larger. Even at laboratory temperatures, the physicist sometimes finds it necessary to cool his electric discharge tube with liquid air

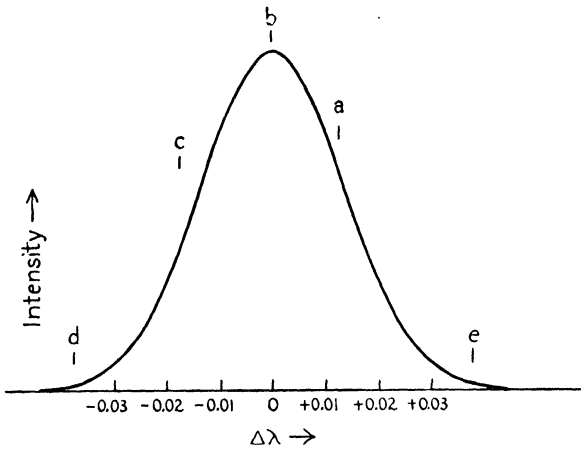

Fig. 50b.—The breadth of a spectral line for pure Doppler broadening (λ 4383 of iron).

This is the profile we would observe if we examined the radiation from atoms emitting at a temperature of 5700° (the temperature of the sun's atmosphere). The intensity of the emitted light is plotted against the wave-length distance from the center of the line. Since atoms absorb in the same frequencies as they emit, this curve also represents the variation of the absorptivity of the atom with wave-length.

in order to narrow and thus separate spectral lines that are close together.

Electric and magnetic fields also widen the spectral lines emitted by atoms. We have seen that when an atom undergoes a transition from one energy level to another, a single spectral line is normally emitted. If, however, the atom is placed near an electrically-charged object or in a magnetic field, it is disturbed by the action of the electric or magnetic

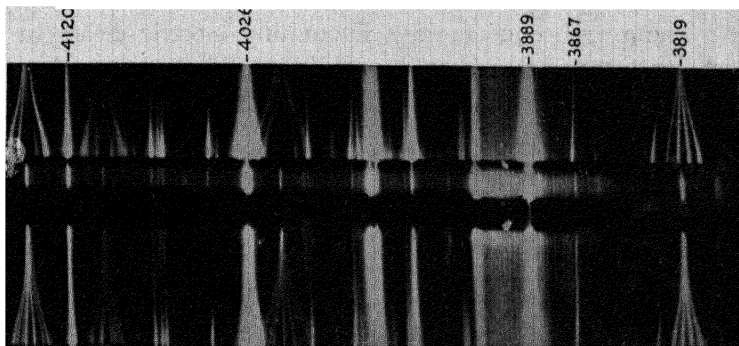

Fig. 51a.—The stark effect in helium.

The field-free spectrum is shown in the center. Not only are the individual lines broken up but the light from the components is polarized, i.e., the wave oscillations from some components are parallel to the electric field, those from others are perpendicular to the field. The upper strip shows the lines polarized parallel to the field, the lower strip those polarized perpendicular. (From a plate by J. S. Foster, courtesy of H. E. White.)

field. The energy of each atomic level may then be changed by certain small amounts, depending on the intensity of the disturbance. We say that each energy level “splits up” into a number of sub-levels. Each line is then divided into a number of fine components, the degree of separation depending upon the intensity of the field (see Figure 51). The splitting of spectral lines in a magnetic field is called the *Zeeman Effect*, and in an electric field, the *Stark Effect*.

The sunspots, which seem to be great cyclones in the solar atmosphere, are always accompanied by powerful magnetic fields. Hence the Zeeman effect is a notable feature of spectral lines observed in sunspots. The effect seems chiefly to be confined to the metallic elements. Quite possibly stellar surfaces are also speckled with spots, but since individual regions of a star’s disk cannot be studied separately, the Zeeman splitting of lines has never been observed in stellar spectra.

The presence of rapidly fluctuating electric fields in stellar atmospheres is well established. There is one important difference between the Stark effect in the labora-

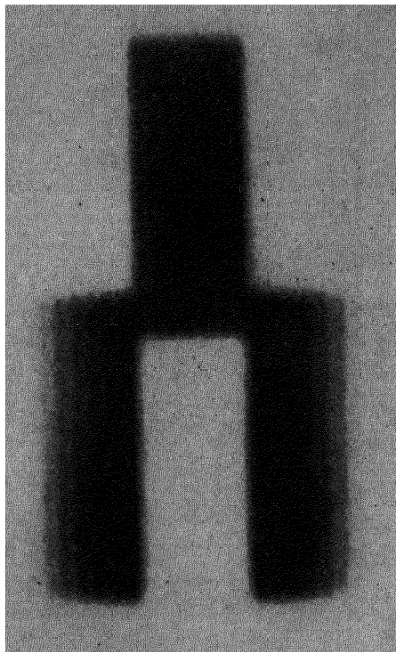

Fig. 51b.—The Zeeman effect.

A single line is broken up into a number of components by a magnetic field. The central components are polarized parallel to the magnetic field, the outer set perpendicular to the field. A polarizing device placed before the slit of the spectrograph is so designed as to allow only the first type of polarized light through to the upper part of the photograph, the second kind to the lower. (*After H. E. White.*)

tory and in a star. In the former case the electric fields produced by laboratory apparatus are constant over volumes billions of times larger than those occupied by the individual atoms. In a star's atmosphere, each atom is

subjected to an individual field of its own, produced by the electrons and ions which happen to be dashing about nearby. At higher temperatures, the space surrounding each atom is filled with rapidly moving positively-charged ions and negatively-charged electrons whose velocities and positions are quite at random. Each charged particle produces a field of different intensity at the radiating atom. One instant the separate fields due to the ions and electrons may nearly cancel at the radiating atom; the next instant a charged particle may make a close approach and the field may become very large. Consequently, the simple Stark splitting of a line such as observed in the laboratory (Figure 51a) is not observed in the stars, since the fields acting on the radiating atoms there are not uniform, but rapidly fluctuating in character and different from atom to atom. Hence the superposition of the radiations from the different atoms of the same element will not coincide, but will overlap to produce a broad, fuzzy spectral line.

The Stark effect seems to be confined principally to the atoms of hydrogen and helium. When the jumping electron is in a distant orbit, and hence not very firmly held by the attraction of the nucleus, it is more easily dislocated by a passing charge, just as the ninth moon of Jupiter is more seriously disturbed by the attraction of the sun than are the inner moons. For this reason, the higher members of the Balmer series, *H*-Delta ($H\delta$), *H*-Epsilon ($H\epsilon$), *H*-Zeta ($H\zeta$), *H*-Eta ($H\eta$), etc., are more affected by Stark broadening than are the earlier members such as *H*-Alpha ($H\alpha$) or *H*-Beta ($H\beta$).

Figure 52 illustrates how dwarfs may be distinguished from supergiants from the appearance of their hydrogen lines. In the dwarf, Zeta Ursa Majoris, the hydrogen lines are strong and broad, whereas they are narrower and weaker in the attenuated atmosphere of the *A*-type super-

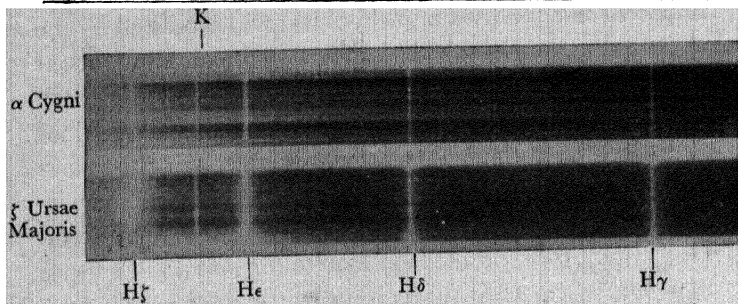

Fig. 52.—The spectra of Alpha Cygni and Zeta Ursae Majoris.

The dwarf, Zeta Ursae Majoris, is about twice the diameter of the sun and many times fainter than the supergiant Alpha Cygni whose diameter is about a hundred times that of the sun. (After W. W. Morgan, Yerkes Observatory.)

giant, Alpha Cygni. You may easily guess the reason for this behavior. In the relatively dense atmospheres of a dwarf, radiating atoms and their disturbing charges are close together; consequently the momentary electric fields are larger and the lines become broadened. In the rarefied supergiant atmospheres, the density is usually so low as to render Stark broadening of minor importance. Hence the lines of hydrogen and helium, although broad and fuzzy in hot dwarf stars, are relatively sharp and narrow in the supergiants.

If the density of a gas is sufficient, radiating atoms may be bumped by passing neutral atoms and the frequency of the emitted radiation then suffers a change. Since these collisions are chance affairs, the observed spectral line is broadened. There is evidence that in the sun, this *collisional broadening* may be more important than natural broadening. As with Stark broadening, collisional broadening is more important for lines arising from electron jumps to and from the larger orbits. Because hydrogen is the most abundant element in stellar atmospheres, encounters of radiating

atoms with hydrogen atoms play the largest role in the collisional widening of spectral lines.

Some years ago Struve and Elvey found evidence that the atmospheres of many stars are not quiescent orderly envelopes but are subject to violent, large-scale, vertical motions amounting to as much as sixty or seventy kilometers per second, which widen spectral lines in much the same fashion as would an exaggerated Doppler effect. These apparently chaotic motions of the atmospheric gases are referred to as *turbulence* and seem to be particularly marked in supergiant stars, which possess very extensive atmospheres.

To summarize; exclusive of instrumental imperfections, spectral lines are broadened by:

(a) *Natural width*, which is due to the fact that an atom, like a radio station, cannot radiate at one sharp frequency;

(b) *Doppler Effect*, which is due to the random motions of atoms in any heated vapor; see, also, (f) and (g), below.

(c) *Zeeman Effect*, which is the splitting of spectral lines by magnetic fields, as in a sunspot;

(d) *Stark Effect*, which is the splitting of a spectral line by an electric field; in stellar atmospheres the lines are broadened because the fields acting on any radiating atom are momentary and at random;

(e) *Collisional Broadening*, which originates because radiating atoms may collide with neutral atoms and suffer a change in their radiated frequencies;

(f) *Turbulence*, or large scale vertical motions of large masses of radiating and absorbing gases in a stellar atmosphere.

(g) *Rotation* of the star itself, which broadens all of the spectral lines (see p. 241). Rotational speeds as high as 200 km/sec. for A stars (Altair) and 400 km/sec. for B stars have been found by Struve and his co-workers.

6

ANALYZING THE STARS

WE HAVE SEEN THAT, FOR STARS OF THE SAME CHEMICAL composition, the appearance of each spectrum line is regulated by the temperature and density of the star's atmosphere. We have found, in this way, that the main features of the spectral sequence are consistent with a series of stars of uniform chemical composition and varying temperature and density. Having thus made the preliminary exploration, we may now fix our attention on the detailed analyses of individual stellar atmospheres. Since the stars in each spectral class share apparently the same general physical characteristics, we have every reason to hope that studies of a small number of representative stars of each type will reveal the nature of the vast majority of stars in the Galaxy.

In making a detailed analysis of a stellar atmosphere, the problem facing us is to discover how the temperature, density and chemical composition of the atmosphere may be deduced from the dark lines in the stellar spectrum. It must be obvious that the intensity, or blackness, of a spec-

tral line is an index to the abundance of the element producing it. But in order to absorb, let us say, the first line of the Balmer series, a hydrogen atom must first be in the neutral condition, and, second, its electron must be in the second energy level (Chap. 3, Fig. 28). In short, the intensity of the line depends upon the temperature and density of the atmosphere as well as on the chemical composition. The exact nature of this dependence will become evident as we examine the process of the formation of an absorption line.

HOW AN ABSORPTION LINE IS FORMED

The path of radiation through a stellar atmosphere is beset by many obstacles, mainly in the form of atoms. Created in the deep interior by the transmutation of the elements (see Chapter 12), radiant energy gradually works its way up through the star and passes from the photosphere to the reversing layer in the form of a continuous spectrum. Most of the radiation usually passes out into space without interference, but those quanta which are of the proper wave-lengths to be swallowed by hungry atoms are absorbed. It is true that every absorbed quantum is reradiated, but whereas the beam of energy from the photosphere flows outward along the line of sight, the radiation emitted by the atmospheric atoms may be thrown off in any direction whatever, backwards and sideways as well as forward. Hence the original outward beam is depleted in the absorbed wave-lengths. Eventually the radiation from the photosphere leaves the star, but only after being mutilated by its encounters with absorbing atoms. When properly interpreted, the marks that the spectrum bears yield a history of the passage of the radiation through the atmosphere—the types and numbers of atoms encountered, as well as the temperature of the gas.

THE NUMBER OF ABSORBING ATOMS

The key to the information we seek is contained in the intensities* of the various spectral lines, which may be measured on the photographic plate with the aid of photoelectric or thermoelectric devices. Consider a dark line at a

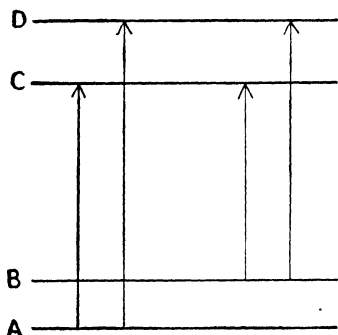

Fig. 53.—Energy levels of a schematic atom.

wave-length belonging to a particular atom. If we say that the line has a certain intensity, or blackness, we mean that a specific amount of energy has been absorbed from the photosphere. The amount of energy removed depends upon the number of atoms per unit cross-sectional area along the line of sight that are absorbing at the wave-length under

consideration. We shall henceforth refer to this quantity as the *number of absorbing atoms*. To clarify the physical meaning of the number of absorbing atoms, we refer to Figure 53, which shows four energy levels, A, B, C and D of a hypothetical atom. Let us suppose that N_a atoms are in level A and N_b in level B, and that the atoms are being struck by radiation of the correct wave-lengths to excite them to levels C and D. Assuming that the impinging radiation is equally intense in all four wave-lengths, A-C, A-D, B-C, and B-D, how many atoms per second will absorb each of the four

* By the intensity of a dark line, we usually mean the amount of energy that it subtracts from the continuous spectrum. The technical term for the intensity is "equivalent width," which is expressed in angstrom units. Thus a line with an equivalent width of 1A has removed an amount of radiation equivalent to that contained in one angstrom of the neighboring continuous spectrum.

radiations? In the first place, the number of absorbing atoms will be proportional to the number of atoms, N_a or N_b , in the lower energy level. Also, one of the properties of atoms is that certain transitions have a greater probability of occurring than others. An atom in level A , for example, will not usually have an equal preference for levels C and D . One or the other will be more inviting. This preference may be expressed by assigning each line a number, usually less than unity, which is known as the f -value for the line. The f -numbers depend only on the structure of the atom, and may be computed from theory or measured in the laboratory. The f -numbers are defined in such a way that the number of absorbing atoms is proportional to the number of atoms times the f -value, i.e., to Nf . Thus the number of atoms absorbing the line $A-C$ is $N_a f_{ac}$. In hydrogen, for example, the f -values of successive members of the Lyman series are, beginning with the first line, 0.42, 0.079, 0.029, 0.014, 0.0078, etc. Since all the lines originate from the same level, the first, we see that the number of absorbing atoms, Nf , diminishes rapidly along the series.

THE CURVE OF GROWTH

The first step in the analysis of a stellar atmosphere is to evaluate the quantity Nf for each line from the observed intensities in the spectrum. To do so we must have a numerical relation between the intensity of the line and the number of absorbing atoms responsible for its production. At first sight it might appear that these quantities should be directly proportional to each other. Actually the relation is somewhat more complicated, and depends on the mechanism responsible for widening the lines. We have already mentioned in Chapter 4 that spectral lines are never perfectly sharp. Each line has associated with it an intrinsic *natural width* due to the fact that the energy levels themselves

are broad (they are zones rather than simple lines), and also a so-called Doppler width arising from the random motions of the absorbing atoms.

To illustrate our argument we shall suppose, for the moment, that above the star's photosphere, which radiates a continuous spectrum, there exists a layer of perfectly motionless absorbing atoms. Only the natural width is of

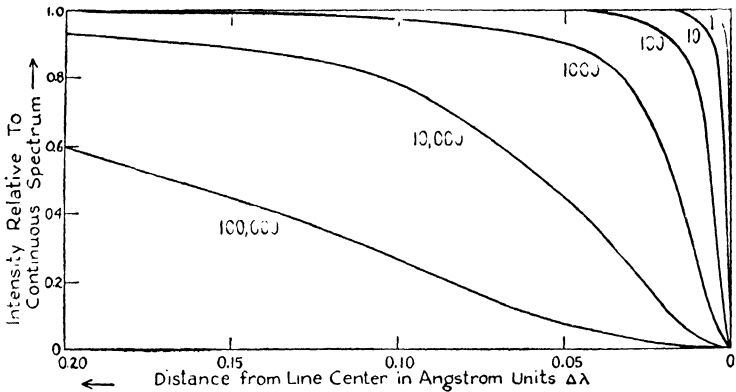

Fig. 54a.—Profiles of absorption lines showing natural width only.

The curves show the change in profile as the relative number of absorbing atoms increases from one to 100,000. Since the profile is symmetrical we plot only half of it. Notice that as the number of atoms is increased, the very strong "damping wings" come into prominence.

importance in producing a broadening of the spectral lines. We shall fix our attention on what happens to the radiation from the photosphere as it passes through a vertical column of this absorbing atmosphere. At the wave-lengths corresponding to absorption lines, the radiation will be depleted by the voracious atoms of the atmosphere. If we now increase the length of the absorbing column, how will the blackness of the line increase? The curves shown in Figure 54a represent the shapes of absorption lines produced by successively greater numbers of absorbing atoms,

as calculated from theory. A large number of atoms act to produce every spectral line; some absorb at the center of the line, and progressively fewer away from the center. Even when few atoms are present and the absorbing column is relatively short, the center of the line is completely black. Figure 49 shows how the absorptivity of an atom varies on either side of the line center; for pure natural width the

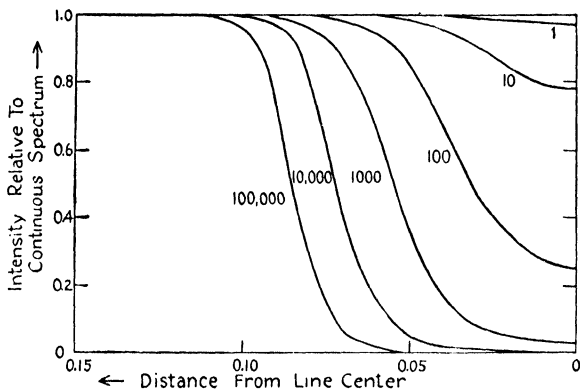

Fig. 54b.—Profiles of absorption lines with Doppler broadening and no natural width.

As in Figure 54a we show only half the profile. Unlike the case of natural damping, for large numbers of atoms the total absorption increases very slowly as the number of atoms increases.

absorptivity is only about two per cent of its maximum value at a distance of three one-thousandths of an angstrom unit from the line center. Nevertheless, as the number of absorbing atoms increases and the line center becomes black, more and more radiation is removed at neighboring wavelengths where the absorptivity may be one hundredth, one thousandth, or one ten-thousandth of its maximum value. Sheer weight of numbers overwhelms the disadvantage of a small absorptivity. Thus much radiation may be absorbed away from the center of the line, in the so-called

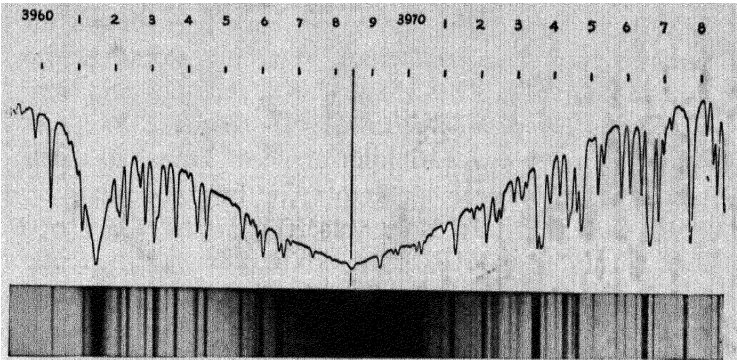

Fig. 56.—The profile of the *H* line in the solar spectrum.

The *H* and *K* lines of ionized calcium are the strongest lines recorded in the spectrum of the sun. The wings are due to natural width and collisional broadening. The profile is reproduced from the Utrecht Solar Atlas. Note wave-length scale at top of figure.

wings. Consequently as the number of absorbing atoms is increased, the intensity, which is measured by the total area under each curve, increases rather slowly, as the square root of the number of absorbing atoms. To double the amount of energy absorbed, four times as many absorbing atoms are required. The resulting relation between the intensity and the number of absorbing atoms, Nf , is shown in Fig. 55*a*. The *H* and *K* lines of ionized calcium in the sun show very pronounced wings due to natural and collisional broadening (see Figure 56).

We now consider a column of atoms in rapid motion, so that broadening by the Doppler effect predominates. We may also assume for the present illustration that the line has no natural width, each atom absorbing only at a wave-length determined by the speed of its motion along the line of sight. The shape of the resulting absorption line will therefore depend upon the relative numbers of atoms absorbing at each part of the line. Since the atoms move about at random, the shape of the line resembles that in Figure

54*b*. As in Figure 54*a*, the curves have been drawn for successively greater numbers of absorbing atoms. Notice that the curves are bell-shaped, with flat tops and very steep sides. The physical meaning of the shapes of the curves is that, in a random distribution of speeds, numerous atoms possess velocities near the zero value but only relatively few have excessively large velocities. Figure 54*b* shows that when the number of absorbing atoms is small the line is not very black, but broad. The energy absorbed is spread out over a wide range of wave-lengths. This is because nearly as many atoms are absorbing slightly away from the center as at the exact center. Accordingly, when more atoms are added, a great deal of energy near the line center is still available for absorption, and the intensity of the line increases directly as the number of absorbing atoms. But the process does not continue indefinitely; the "growth" slows down. Eventually, as more atoms are added, the line becomes black at the center, and since few atoms have high enough velocities to absorb very far away from the zero position, the line becomes "saturated." In other words, no matter how many additional atoms are added to the absorbing column, very little more energy can be extracted from the continuous background. The corresponding relation between intensity and number of absorbing atoms, $\mathcal{N}f$, is shown in Figure 55*b*. The shape of the curve evidently depends upon the temperature, for, at high temperatures, large numbers of atoms possess high speeds, more energy is available for absorption, and the line does not become saturated until a relatively high intensity is attained.

In reality, neither of the two modes of line broadening we have been describing operates independently. The two are combined, but in such a way that Doppler broadening prevails for small numbers of absorbing atoms and natural broadening for large numbers. The resulting relation

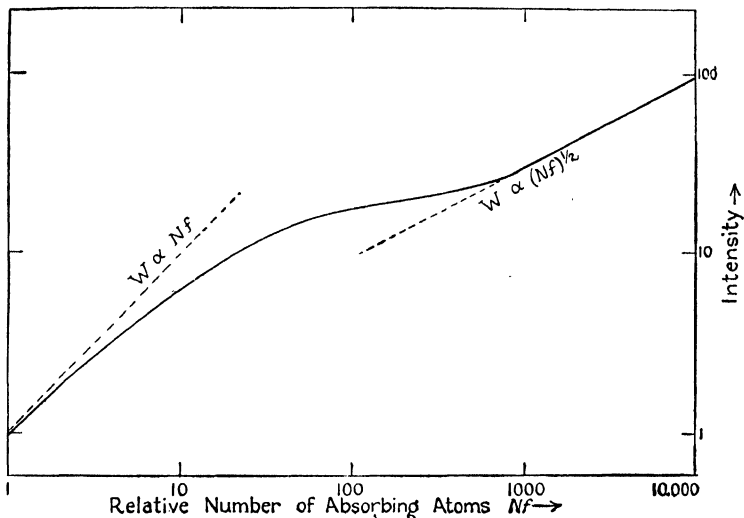

Fig. 57.--The theoretical curve of growth.

The solid line gives the relation between the number of absorbing atoms and the intensity. The dotted lines represent the two limiting forms of the relationship $I \propto Nf$ for small intensities and $I \propto \sqrt{Nf}$ for large intensities. The scale is logarithmic.

between intensity and number of absorbing atoms, which is known as the *curve of growth* has the form shown in Figure 57. In figures 58 and 59 we illustrate observed curves of growth for the Λ -type dwarf, Gamma Geminorum, and the sun.

But what about the other causes of line broadening: Stark effect and Zeeman effects, collisional broadening, turbulence and rotation? The Stark effect is of importance only for hydrogen and helium; the Zeeman effect exists only in magnetic fields and it is unlikely that such fields cover any large portion of a star's surface. Collisional broadening affects the shape of an absorption line in the same fashion as natural broadening and, as far as the curve of growth is concerned, it can be treated theoretically in exactly the same way.

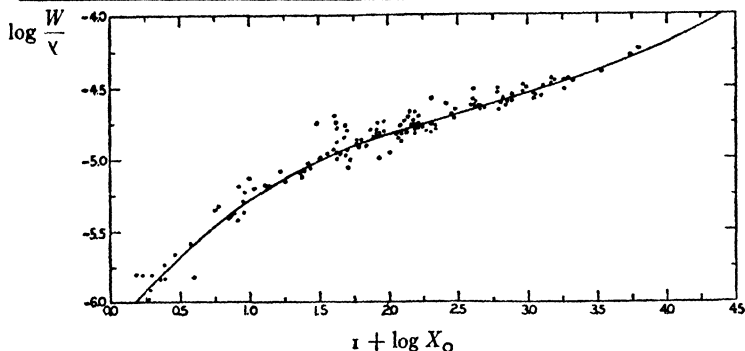

Fig. 58.—Curve of growth for the sun.

Based on measures by C. W. Allen at Canberra, Australia. The quantity W/λ is the equivalent width divided by the wave-length of the line in angstroms and X_0 is proportional to Nf , the number of absorbing atoms. (*Astrophysical Journal*.)

Turbulence affects the shape of an absorption line as does Doppler broadening. In the calculation of the curve of growth it is necessary to use merely the mean of the vertical velocities of the large-scale masses of gas, rather than the mean of the velocities of the individual atoms. Stellar rotation tends to broaden the star's spectral lines, and makes the line profiles characteristically "dish-shaped."

From the curve of growth, we may read off the number of absorbing atoms for each line whose intensity has been measured in the spectrum. This number, divided by the f -value, yields the number of atoms in the lower of the two energy levels corresponding to the observed line. Frequently, an element is represented in the ordinarily observable spectrum by lines from a single energy level—hydrogen, for example. But atoms very often display lines arising from a large number of different levels. Such is the case for iron or titanium. When this occurs we may calculate the temperature of the stellar atmosphere, for the relative numbers of atoms that are excited to the various

energy levels of an atom are governed by the temperature (see Appendix G). At a high temperature there may be an appreciable number of atoms in the higher energy levels. At a low temperature the higher energy levels are sparsely populated. If only a single atomic level is represented, we may, if we know the temperature, compute the atomic

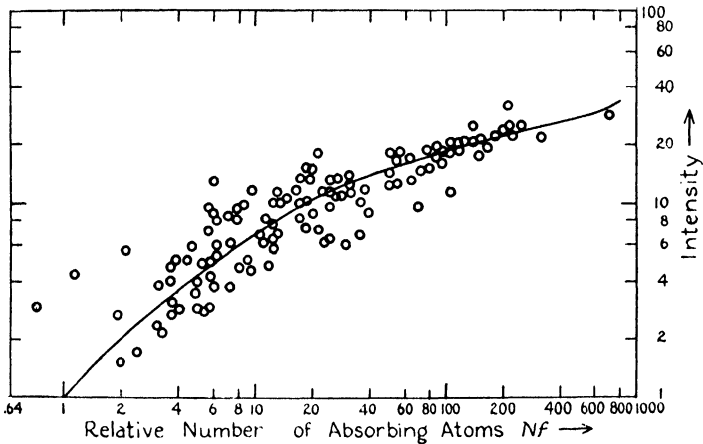

Fig. 59.—The observed curve of growth for Gamma Geminorum.

In this *A*-type dwarf there are no strong metallic lines. Many lines are weak and fall on the Doppler portion of the curve of growth. The scatter is great for weak lines whose intensities cannot be measured very accurately. (From observations obtained at the McDonald Observatory.)

population of all the energy levels that are not represented. Then by summing the numbers of atoms in each level, we obtain the total abundance of each element in the stellar atmosphere.

Strictly speaking, we do not determine the total abundance of the element, only the number of atoms that are neutral or ionized, depending upon which lines are observed in the spectrum. A majority of the sodium atoms in the atmosphere of the sun, for example, are ionized. But

the lines of ionized sodium occur only in the far ultraviolet region of the spectrum, which cannot penetrate the earth's atmosphere. Only the neutral sodium lines are observed. We saw in Chapter 4, however, that the ratio of neutral to ionized atoms is related by Saha's formula to the number of free electrons and the temperature. When the spectrum shows both the neutral and ionized lines of some element as, for example, calcium in the cooler stars, Saha's formula may be employed to calculate first the number of free electrons, and then the amount of ionized sodium. Thus we get the total amount of sodium, whatever its state, from an analysis of spectral lines we can easily observe.

Only a little more than ten years have elapsed since developments in atomic theory led to the discovery of the curve of growth as a powerful weapon for stellar analysis. Since then it has been applied extensively in studies of stellar atmospheres. Most thoroughly analyzed has of course been the nearest star, our sun. Before the advent of the curve of growth, the most thoroughgoing analysis of the solar atmosphere was carried out by Professor Henry Norris Russell, of Princeton. We shall not describe the method he employed, since it is now chiefly of historical interest. Nevertheless, in spite of the fact that, as Professor Russell puts it, the investigation was in the nature of a reconnaissance of the solar territory, his results have not been seriously altered by later studies based on the curve of growth, which is a tribute to Russell's remarkable resourcefulness and ingenuity.

THE COMPOSITION OF THE STARS

According to a tabulation in 1937 by Charlotte E. Moore, an associate of Professor Russell at Princeton, sixty-one of the ninety-two chemical elements have been defi-

nately identified in the solar atmosphere, as shown in the following table:

Hydrogen	Calcium	Yttrium	Neodymium
Helium	Scandium	Zirconium	Samarium
Lithium	Titanium	Columbium	Europium
Beryllium	Vanadium	Molybdenum	Gadolinium
Boron	Chromium	Ruthenium	Dysprosium
Carbon	Manganese	Rhodium	Erbium
Nitrogen	Iron	Palladium	Thulium
Oxygen	Cobalt	Silver	Ytterbium
Fluorine	Nickel	Cadmium	Lutecium
Sodium	Copper	Indium	Hafnium
Magnesium	Zinc	Antimony	Tungsten
Aluminum	Gallium	Barium	Osmium
Silicon	Germanium	Lanthanum	Iridium
Phosphorus	Rubidium	Cerium	Platinum
Sulphur	Strontium	Praseodymium	Lead
Potassium			

The elements that are missing from the list should not be regarded as absent from the solar atmosphere. The spectra of many of the absent elements have not been studied sufficiently in the laboratory; others have their most important lines in inaccessible regions of the spectrum, while the remaining atoms, judging from their scarcity on the earth, may be present in the sun in such minute quantities that their lines cannot be detected.

From a recent analysis by D. H. Menzel and his collaborators at Harvard, we have listed in Table 7 the amounts of some of the more abundant elements in the solar atmosphere. The first column contains the element, the second its percentage abundance by number of atoms, i.e., volume, and the third column the total amount of mass that each element contributes to a column of the atmosphere one square centimeter in cross-section extending vertically above the photosphere.

The most remarkable feature of the table is the great abundance of hydrogen and helium. Over 80% of the solar atmospheric atoms are hydrogen, which suggests why the lines of hydrogen persist over such a wide range of tempera-

TABLE 7
ABUNDANCES OF ELEMENTS IN THE SOLAR ATMOSPHERE

	<i>Percentage volume</i>	<i>Mass (milligrams per square centimeter)</i>
Hydrogen	81.760	1200
Helium	18.170	1000
Carbon	0.003000	0.5
Nitrogen	0.010000	2.
Oxygen	0.030000	10.
Sodium	0.000300	0.1
Magnesium	0.020000	10.
Aluminum	0.000200	0.1
Silicon	0.006000	3.
Sulphur	0.003000	1.
Potassium	0.000010	0.003
Calcium	0.000300	0.2
Titanium	0.000003	0.003
Vanadium	0.000001	0.001
Chromium	0.000006	0.005
Manganese	0.000010	0.01
Iron	0.000800	0.6
Cobalt	0.000004	0.004
Nickel	0.000200	0.2
Copper	0.000002	0.002
Zinc	0.000030	0.03

tures in stellar atmospheres. We note too that although the *H* and *K* lines of ionized calcium are the strongest in the observable region of the spectrum, several other elements are much more abundant. The ionized calcium lines are strong because they originate from the lowest energy level,

where most of the atoms reside. Hence nearly all ionized calcium atoms are capable of absorbing these *H* and *K* lines. On the other hand, the strongest lines in the spectrum of abundant magnesium occur far in the hidden ultraviolet.

Most of the stars in the sky have very nearly the same composition as the sun,* although a few appear to be overstocked with one element or another. Some are overladen with carbon, others with strontium or with silicon, and still others with sulphur. The divergences appear to be confined mainly to the very cool stars of classes *M*, *N*, *R* and *S*, and to the extremely hot Wolf-Rayet stars.

THE HAZINESS OF STELLAR ATMOSPHERES

Strictly speaking, there is no sharp dividing line between the photosphere of a star and its atmosphere. As we look down through successively deeper layers of the atmosphere, we eventually arrive at a point where the gaseous material is completely opaque. This level, the depth at which the atmosphere becomes completely opaque, is what we commonly refer to as the "surface" or photosphere of a star. The size of the "atmosphere" thus depends upon the absorptivity of its material. In a dwarf star, where the gases are compressed, we can penetrate only through a relatively short thickness of material, and the depth of the atmosphere is thus small. In a giant star, however, the density is so low

* A. Unsold has recently analyzed the spectrum of the *B* star, Tau Scorp*ii*, from plates taken at the McDonald Observatory. A number of lines of the lighter elements are well observed in this star, and Unsold has derived the following relative abundances (by weight):

Hydrogen.....	1.0	Nitrogen.....	0.005
Helium.....	0.7	Oxygen.....	0.016
Carbon.....	0.002	Neon.....	0.022

that we can see through a great depth of the atmosphere, which is said to be "extended."

The third column of Table 7 shows that a surprisingly small amount of solar material, about two grams per square centimeter column, is sufficient to "black out" the radiation from below the photosphere. The total amount of matter in the solar atmosphere, which is 10^{17} , or one hundred thousand million million tons, is huge only because of the sun's great size, for it represents only one part in twenty thousand million of the whole solar mass. We can only infer that the gases in stellar atmospheres are exceedingly hazy. If the earth's atmosphere with its relatively great density were as opaque, we could scarcely see as far as fifty feet.

The explanation for the foginess of stellar atmospheres lies in the fact that gases in the process of becoming ionized are highly opaque. We know, of course, that the atoms in a stellar atmosphere strongly screen radiations in the neighborhood of absorption lines, because an atom raised to higher energy levels absorbs energy corresponding to discrete wave-lengths. But when an atom becomes ionized it may absorb energy of *any* frequency greater than the minimum amount necessary for ionization. Thus the ionization of hydrogen atoms whose electrons are in the second orbit produces a continuous absorption spectrum stretching to the violet of the Balmer series limit at 3650\AA (see Figure 60), while the ejection of electrons from the third orbit screens off energy at wave-lengths shorter than the limit of the Paschen series at 8210\AA in the infrared. It is clear that hydrogen atoms cannot play an important role in producing a haziness in the observable spectral regions of stars, unless a fair fraction of them is excited to the second and higher levels. Only those atoms excited to at least the second level can absorb radiation from the limit of the observable

spectrum at 2900A down to 3650A; and only those excited to at least the third level can absorb radiation in the part of the spectrum from 8210A to 3650A. In the atmosphere of the sun * the theory of the excitation of atomic levels suggests

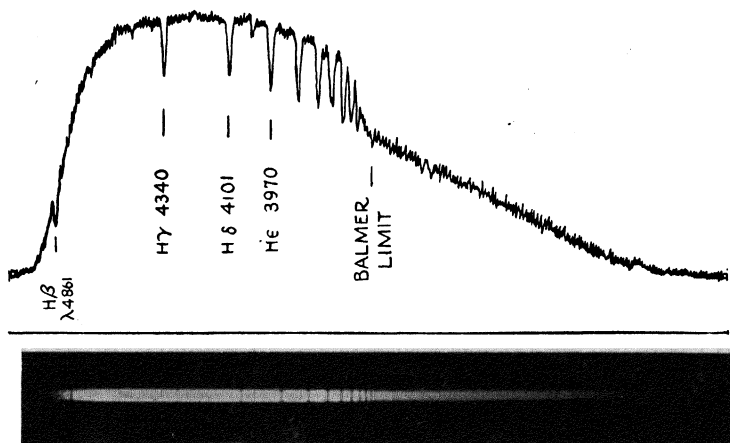

Fig. 60.—The continuous absorption at the limit of the Balmer series of hydrogen.

The continuous absorption beyond the Balmer limit at 3650 is produced by hydrogen atoms which become ionized from the second energy level. We reproduce here a spectrogram of the star π_1 Cygni (see Fig. 13) and also a microdensitometer tracing of the plate which shows how the blackening of the film changes with wave-length. Notice the dips corresponding to the absorption lines. (*Lick Observatory.*)

that probably only four or five hydrogen atoms out of every thousand million are in the second level so that, in spite of its great abundance, atomic hydrogen contributes but slightly to the opacity. In an *A*-type star many hydrogen atoms are excited to the second and higher levels and absorption by atomic hydrogen becomes very important. Figure 60 shows

* In this calculation an excitation temperature of 5700° has been adopted. See Appendix G, page 308.

the strong absorption at the limit of the Balmer series in a *B* star.

The ionization of metallic atoms undoubtedly plays a similar role in lowering the transparency. In the cooler stars the overlapping wings of the atomic lines and molecular bands may contribute significantly to the opacity.

Another very interesting source of opacity has recently been found by Wildt of Princeton. In stars as cool as the sun, or cooler, a neutral hydrogen atom may acquire a second electron and thus become a negatively-charged ion. These negative ions are voracious absorbers of energy in ordinary regions of the spectrum. Different types of absorption processes are effective at different temperatures. We have seen that in the intermediate and late spectral classes the temperatures are so low that few hydrogen atoms are in the second and third levels waiting to be ionized. In these stars the opacity seems mainly to be produced by the ionization of negative hydrogen ions. In the hotter stars, the ionization of neutral hydrogen atoms is without doubt the major source of opacity.

Theory agrees with observation in predicting that the atmospheres of the hotter stars should be more opaque than those of the cooler stars. Thus the atmosphere of Sirius is about twenty times as opaque as that of the sun.

A CROSS-SECTION OF A STELLAR ATMOSPHERE

Analysis of the ordinary absorption-line spectrum of a star leads to an understanding of the average physical conditions in the atmosphere. The starlight that reaches us passes through many different levels of the atmosphere, and we therefore receive the superimposed messages from atoms exposed to a variety of temperatures and densities. Are the elements distributed uniformly throughout each stellar envelope? Or do the heavier gases settle downwards,

much as chlorine tends to concentrate toward the ground on the earth? The answers to these questions may be found from studies of a remarkable class of eclipsing stars, which enable us to see just how temperature, density and composition change with depth in a stellar atmosphere.

Best known of such systems is Zeta Aurigae, consisting of a hot *B8* star, which has eight times the sun's mass, and a cool, supergiant *K4* star which is twice as heavy as the *B* star. The diameter of the *K4* star is roughly 170,000,000 miles, and its average density 3 millionths that of water, whereas the *B8* star is about three million miles in diameter, and its density a half that of water. The *B8* and supergiant stars circle one another in an orbit 1,000,000,000 miles in diameter in a period of 972 days. Periodically, the small star disappears behind the large one to remain eclipsed for an interval of about 60 days.

Before the eclipse, the spectrum of the star is a composite of two spectra, with most of the blue and violet energy produced by the hot star, and the yellow and red radiation due to the *K* star. But as the small star moves behind the atmosphere of the large one (see Figure 61), its light shines through and is absorbed by the atoms in the envelope. Consequently, the violet region of the spectrum begins to carry the imprint of the cooler gases of the large star, and as greater thicknesses of atmosphere are traversed, the spectrum changes. Eventually the *B* star disappears completely and only the

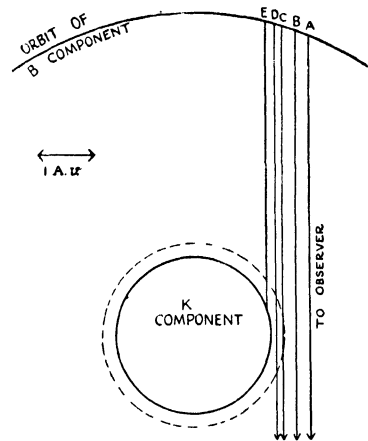

Fig. 61.—Schematic diagram of the system of Zeta Aurigae.

spectrum of the cool star remains. The extinction is gradual, for as D. H. Menzel puts it: "There is no eclipse in the ordinary sense. The *B* star sinks into obscurity behind the *K*, like a planet setting in a smoky atmosphere, disappearing before it reaches the horizon." The spectrum at each stage of the eclipse of the *B* star thus carries a record of the physical conditions in each section of the *K* star's atmosphere.

Dr. Olin C. Wilson, of Mount Wilson Observatory, is now engaged in a thorough analysis of the *K* star envelope, from spectra recorded by him at the eclipse in December, 1939. By applying the curve of growth separately to the lines in each spectrogram taken during the course of the eclipse, he is making a detailed study of the chemical composition and density in different regions of the *K* star atmosphere.

Small sections of the excellent spectra obtained by Dr. Wilson are shown in Figure 62 for five different stages during the ingress of the *B* star. The region of the spectrum that we have selected for reproduction is in the ultraviolet, where some of the most interesting changes take place. Before the eclipse, the spectrum is typical of an ordinary *B8* star, consisting mainly of rather broad hydrogen lines, on a strong continuous background. As the rays of the *B* star begin to traverse the upper atmosphere, strong, narrow hydrogen lines together with the *H* and *K* lines of ionized calcium begin to appear (Figure 62*a*).^{*} Next to appear are the lines of ionized metals, as the hydrogen and calcium lines continue to grow in strength. As the *B* star begins to shine through denser strata of the cool envelope, the lines of neutral metals become prominent. Finally, the hot star is completely extinguished (Figure 62*e*), and we observe

^{*} Observations of the solar atmosphere during eclipses by the moon also show that hydrogen and calcium extend higher in the atmosphere than all other elements (see Figure 26).

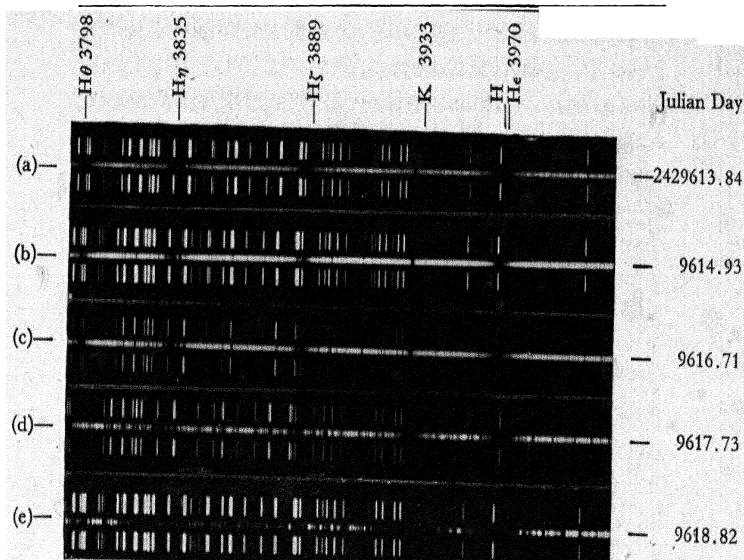

Fig. 62.—The spectrum of *Zeta Aurigae* in the ultraviolet.

(From spectrograms taken at the Mount Wilson Observatory.)

the sharp metallic lines and powerful *H* and *K* absorptions typical of a *K4* supergiant. At the end of the eclipse, when the *B* star emerges from behind the *K*, the various spectra appear in the inverse order.*

A detailed account of the structure of the supergiant atmosphere must await the completion of Wilson's investigation, but studies during earlier eclipses have brought out the fact that the hydrogen atoms extend out from the photosphere to a distance of nearly 20,000,000 miles. The

* The observations are plotted against the Julian Day. The Julian Day Calendar numbers the days consecutively since the beginning of the Julian Era, 4713 B.C., rather than by the usual system of years, months, and days. The Julian Day begins at noon, Greenwich Civil time (or 7 a.m. Eastern Standard Time) and uses decimals of a day, rather than hours, minutes, and seconds. See Campbell and Jacchia, *The Story of Variable Stars*, p. 29. The Harvard Books on Astronomy.

remarkable thing is that the material thins out so slowly. For a star with the mass and radius of Zeta Aurigae, the force of gravity at the surface is so great that the density of material in the atmosphere should decrease fifty times more rapidly than it does! As in the solar atmosphere, some yet

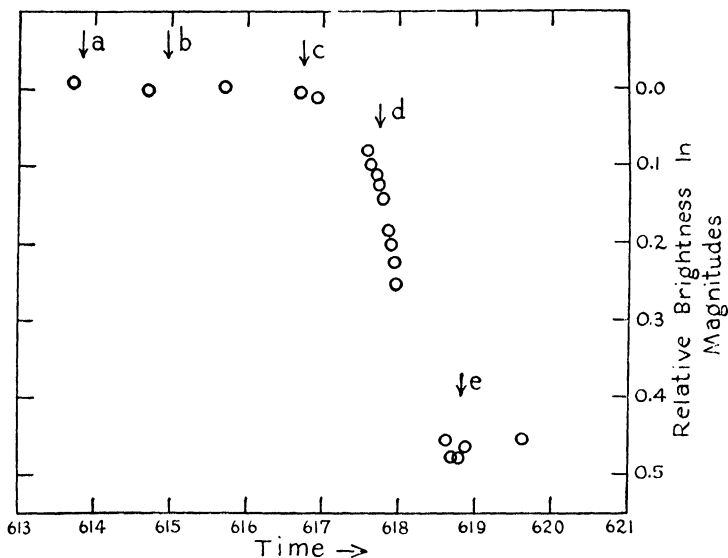

Fig. 63.—The light variation of *Zeta Aurigae* in the 1939 eclipse.

These observations of the brightness of Zeta Aurigae at the beginning of the 1939 eclipse were obtained by F. E. Roach at the Steward Observatory. The times at which the Mount Wilson spectrograms were obtained are indicated by the letters and arrows.

unknown force or forces counteracts the pull of gravity and thus maintains the envelope of Zeta Aurigae in its swollen condition.

CHEMICAL COMPOUNDS AND THE COOL STARS

The world we live in is a world of molecules. The book you are reading, the hand that holds it, the chair you are

sitting in, are all constructed of molecules. The hot stars, on the other hand, are worlds of atoms, ions and electrons, where the complexity of coolness is replaced by the simplicity that accompanies high temperature. The link between our world and that of the stars is to be found in the cooler stars, where the pace is leisurely enough to allow atoms to unite in the fellowship of molecules. Even there, however, the atomic organizations are relatively simple. Carbon and nitrogen atoms join to form cyanogen, CN, oxygen and hydrogen unite in the hydroxyl molecule, OH, oxygen combines with titanium in the form of titanium oxide, etc. It is only under the comparatively frigid conditions on the earth that atoms are permitted to give full rein to their organizing talents. The carbon atom on the earth, for example, is a master in the art of forming complex molecules. Some atoms of carbon, hydrogen, and oxygen cluster together in hexagons, others in long chains, like popcorn on a string. Carbon forms the base of all compounds found in living creatures; it is the atom that is mainly responsible for the complexities of the living world.

The growth of the simple into the complex is illustrated by the growing intricacy of stellar spectra as we pass from the very hottest stars, where only a few lines produced by atoms and ions are found, to the other end of the sequence, where the spectra of the cool stars are dominated by the complex bands of molecular compounds. In the chemical analysis of the cool stars we are no longer dealing with the lines of atoms, whose abundances may be calculated from the curve of growth, but with broad bands. Theoretically, each fine component of a band may be treated as a line produced by a certain number of absorbing molecules. Actually, in most stellar spectra, the lines are too close together to be separately resolved, and the straightforward method of analysis cannot be applied.

A somewhat indirect method of attack was developed by Russell to calculate molecular abundances. In analogy with the intensities of atomic lines, the total blackness of a molecular band depends upon the abundance of the molecule, and upon the temperature and density of the stellar atmosphere. The abundance of the molecule in turn depends upon the abundances of its constituent atoms. Russell began by assuming various mixtures of atoms, and then predicted the numbers of molecules of each type to be expected from each mixture. The problem is a chemical one involving reactions between atoms and molecules. Let us suppose that two atoms, which we may designate as A and B , e.g., titanium and oxygen, react to form the molecule AB , and that the molecule may also decompose into its separate atoms. The reactions may be expressed symbolically as follows:

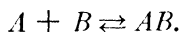

The two inverse processes go on until the rates at which they occur just balance. We then say that the two reactions are in equilibrium. The relative numbers of atoms and molecules that result depend upon the temperature and the amount of energy necessary to dissociate the molecule. The process is exactly analogous to the ionization of atoms, and may in fact be represented by a formula similar to that derived by Saha for atoms, ions and electrons (see Chapter 4):

$$\frac{(\text{Number of } A \text{ atoms}) \times (\text{Number of } B \text{ atoms})}{(\text{Number of molecules } AB)} = k \text{ (which depends on the temperature and kind of molecule).}$$

This equation is known as the *dissociation formula*.

Russell first proceeded to investigate an atmosphere of the same composition as the sun's, in which oxygen is much

more abundant than carbon, (see Table 7). By applying the dissociation formula, Russell found that, at temperatures somewhat lower than that of the sun, molecular carbon, C_2 , the hydrocarbon, CH , and cyanogen, CN , are very abundant. The most numerous molecule of all is hydrogen, H_2 , but its bands do not occur in the observable spectral region. At still lower temperatures (about 3000°), the formation of the very stable carbon monoxide molecule CO , the familiar and lethal constituent of automobile exhaust fumes, steals the carbon away from other molecules. Russell's predictions seem to be fully verified in the *K* and *M* stars, which indicates that the stars in this branch of the sequence are identical with the sun in chemical make up.

An interesting feature of Russell's theoretical calculations is that they predict marked differences between the intensities of cyanogen bands in giants and dwarfs. Among cool stars of the same temperature, the CN bands should be stronger in the giants than in the dwarfs. The tendency of the molecule to remain dissociated at low densities is counteracted by the fact that the dwarf atmospheres are excessively hazy. We observe to much greater depths in the giants. But when comparing stars of the same spectral class, we find the CN bands are considerably stronger in the giants, because dwarfs are hotter than giants of the same spectral class, and high temperature favors dissociation of the molecules.

One of Russell's aims was to attempt to explain the so-called "branching" of the spectral sequence near class *K2*. In class *K5*, bands of titanium oxide appear, and steadily strengthen through the subdivisions of class *M*. But the spectra of classes *R*, *N*, and *S*, although seeming to merge into class *K*, show peculiar differences from each other and from class *M*. Thus class *S* is characterized by abnormally strong bands of zirconium oxide, classes *R* and *N* by bands

of carbon, and class *R* by intense bands of cyanogen. R. H. Curtiss suggested years ago that the splitting of the spectral sequence is mainly due to small differences in chemical composition. Thus the *S* stars contain an excess of zirconium, the *R* and *N* stars an overabundance of carbon, while the weakness of cyanogen (CN) in *N* stars could be ascribed to a paucity of nitrogen.

In the second phase of his investigation Russell interchanged the abundances of carbon and oxygen in the sun, leaving the other elements unaffected. Under these conditions the amount of TiO in the cool stars becomes negligible. On the other hand, the bands of CH, CN, and C₂ become enormously strong, in agreement with what is observed in the *R* and *N* stars. In addition, Russell finds the strength of zirconium oxide bands in the *S* stars to be consistent with an excess of zirconium in these stars and the weakness of the violet CN bands in the *N* stars as compared with the *R* stars to be in harmony with a scarcity of nitrogen.

Although Russell's calculations are entirely theoretical, we have here the first evidence of departures from uniformity in the chemical compositions of the stars. The actual analysis of the star *R* Coronae Borealis, whose temperature is high enough to permit the presence of carbon in atomic form, yields still another experimental verification of his conclusions. Berman finds that among the elements observed in this star, carbon contributes 69%, hydrogen 27%, nitrogen less than 0.3%, and the metals (mainly magnesium and iron) about 4%, by volume.

Accurate determinations of the chemical compositions of the stars are difficult, chiefly because the *f*-values, which are necessary for the theoretical interpretation of the data of observation, are known exactly only for the hydrogen atom. For other, more complex, atoms, theory gives only approximate values, although the approximation is satisfactory

for simple atoms like helium, sodium, potassium, and calcium. In recent years, R. B. King, of Mount Wilson, has measured f -values for lines of iron and titanium in the laboratory. The extension of this important work to additional elements promises to yield improved information on the abundances of the various elements in the Universe, and on possible variations in composition among the stars and nebulae.*

In our description of the analysis of starlight we have chosen to emphasize the "curve of growth" method. One advantage of this method is that it calls only for observations of the total energy absorbed in the dark lines, for which excessive instrumental accuracy is not required. Its drawback is that it treats the entire stellar atmosphere in one piece, without differentiation in depth. Detailed knowledge of conditions in the various layers of a stellar atmosphere may be obtained from studies of individual line profiles, when the observations are sufficiently accurate. This method of analysis will certainly grow in importance as instrumental techniques are improved.

* Even when the theory of ionization and the curve of growth effects are taken into account, a number of stars show abnormal line intensities which cannot be accounted for by the elementary theory. For example, some A stars show the K line of ionized calcium abnormally weak as compared with the lines of ionized Mg, Fe, Ti, Cr, and Si. In other stars lines of certain ions are very strong. In some A stars MnII, or SrII may be abnormally intense while in others SiII is exceptionally strong. Struve and Swings have proposed that these effects are not due to differences in chemical composition but arise from peculiar excitation mechanisms. They suggest, for example, that the CaII ion may suffer abnormal ionization from absorption of radiation from a bright Lyman Beta line just beyond the series limit. They explain abnormal line intensities in stars such as P Cygni by the fact that the radiation impinging upon the atmospheric atoms deviates considerably from that of a black body. Special excitation mechanisms are known to be operative in the planetary nebulae (see p. 194).

7

PULSATING STARS*

NOTHING COULD BE FARTHER FROM THE TRUTH THAN the phrase "as fixed and immutable as the stars." Stars that hurtle through space at speeds of dozens of miles per second can hardly be regarded as fixed. As for their immutability, motion pictures of the sun taken at the McMath-Hulbert Observatory show that the surface of a typical star is in a continual state of turbulent motion, with occasional explosions that send great clouds of gas spurting hundreds of thousands of miles from the surface (see Figure 64). In their average characteristics, however, most of the stars that we have been considering remain very much the same from day to day, from month to month, and from year to year. In the following chapters we shall encounter stars that depart radically from the run of the mill variety. Relatively few in number, these stars appear peculiar when compared with their more normal fellows. They nevertheless merit close attention, for the apparent exceptions in the universe may well supply the missing links in theories of the constitution and evolution of the stars.

* See Chapters 4 and 5, *The Story of Variable Stars* by Campbell and Jacchia, The Harvard Books on Astronomy.

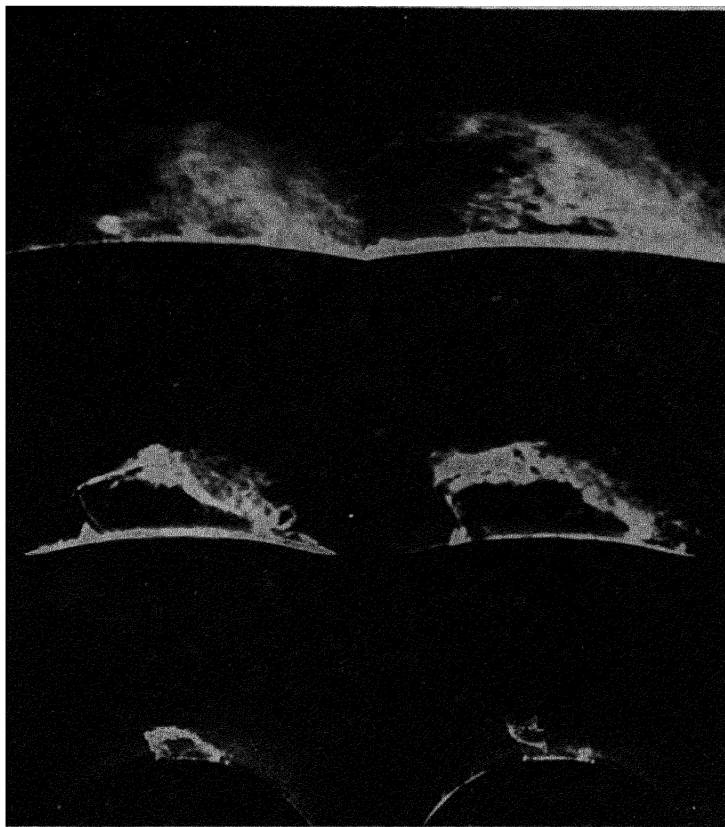

Fig. 64.—Stellar explosions—prominences on the surface of the sun.

This series of photographs made in the light of the *K* line of ionized calcium shows the development of a large incandescent gaseous mass, a prominence of the quasi-eruptive type.

1939	August 24	15 ^h 32 ^m	20 ^h 37 ^m
	August 25	13 42	17 19
	August 25	18 49	21 7

Notice the change in scale in the successive pairs of photographs. The size of the prominence increases with time.

At the time the lower four photographs were taken, the gaseous material was in rapid motion along the arch from right to left, and eventually disappeared into the sun (*McMath-Hulbert Observatory*).

We devote our attention in this chapter to stars that make themselves conspicuous by winking at us from the sky. The *variable stars* are so named because they fluctuate in brightness, some periodically and others irregularly, by amounts ranging up to a factor of several hundreds in apparent brightness. The periodic variables have been divided into two groups, the so-called *Cepheid* variables, with periods less than about 100 days, and those with longer periods. We shall see that the division is not entirely arbitrary, but that the two groups possess widely different physical attributes.

THE CEPHEID VARIABLE STARS

Before discussing the question of what makes a variable star vary, we shall find it useful to summarize some of the known facts of Cepheid variables. Named after the star Delta Cephei, the first of its kind to be discovered, these stars appear to fall into two sub-groups, the *cluster-type* Cepheids, which are often found in large numbers in the globular star clusters (see Figure 65), and have periods less than about 0.8 of a day, and the *classical* Cepheids, with periods longer than about one day. Some of the observed features of typical Cepheid variables are listed in Table 8. The star *RR Lyrae* is a cluster-type Cepheid, while the others are all of the classical type. The second column contains the period of the light variation in days, and the third and fourth columns the apparent magnitudes at maximum and minimum light. We see that the light range varies from 0.1 of a magnitude for our well-known friend the North Pole Star to 1.5 magnitudes for *X Cygni*. The curve representing the variation of apparent magnitude with time, the so-called light curve, is shown for Delta Cephei in the upper half of Figure 66. The cycle is characterized by a steep rise to maximum light, and by a much

slower decline to minimum. There is a slight hump on the descending branch of the light curves of certain Cepheids. Observations of the spectra of Cepheid variables show that the spectral lines also undergo displacements in the same



Fig. 65.—The globular star cluster 47 Tucanae.

This star cluster has an apparent diameter of nearly a degree and appears about the 4th magnitude to the eye. Intrinsically it is about a million times as bright as the sun, and ten times as luminous as the ordinary globular cluster. It has a distance of 25,000 light years, and a diameter of 400 light years. (*Photographed at the Boyden station of the Harvard Observatory with the 60-inch reflector.*)

period as the light variation. If we interpret the line shifts as due to the Doppler effect, we find that the radial velocity of Delta Cephei changes according to the lower curve of Figure 66. A remarkable feature of the velocity curves of Cepheid variables, which any successful explanation of the light variation must account for, is that they are almost exact mirror images of the light curves, with maximum

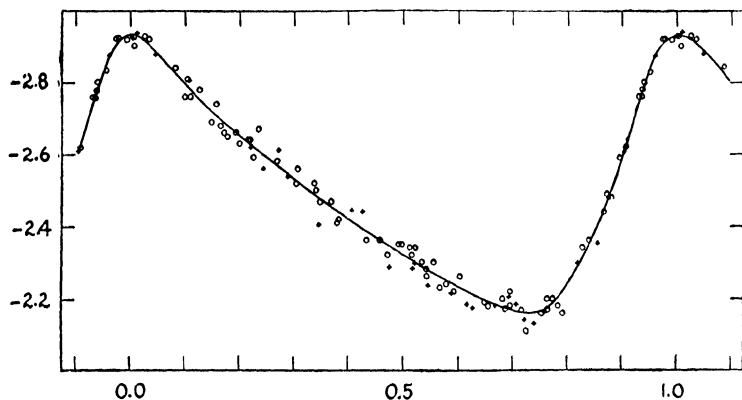

Fig. 66a.—The light curve of *Delta Cephei*.

In this curve, reproduced from a paper by M. Schwarzschild, magnitude is plotted against phase (fraction of period of the variable). The observational data are those of Stebbins (circles) and Danjon (crosses).

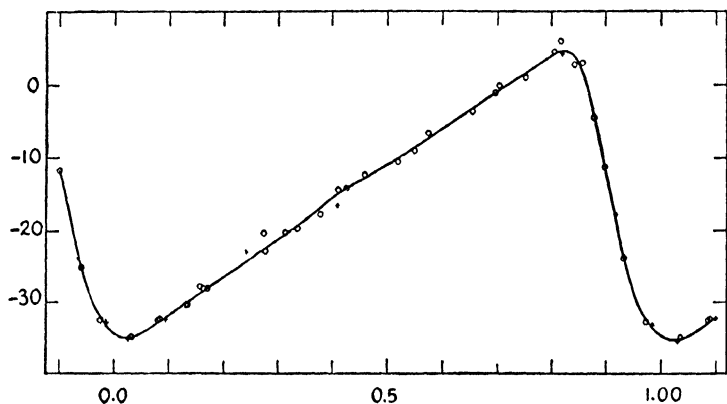

Fig. 66b.—The radial velocity curve of *Delta Cephei*.

Radial velocity in kilometers per second is plotted against fraction of a period. The observational data are those of Jacobsen (circles) and Henroteau (crosses). The observed radial velocity represents the combined effect resulting from the pulsations and from a velocity of approach to the sun of -16 km/sec for the star as a whole.

light occurring simultaneously with, or slightly earlier than, the greatest velocity of approach. The appearance of the spectrum also changes with time. The spectral class of Delta Cephei, for example, is *F*4 at maximum and *G*6 at minimum, and the temperature ranges from 5600° to 4730°, according to M. Schwarzschild.

TABLE 8
SOME FEATURES OF CEPHEID VARIABLE STARS

Star	Period <i>P</i>	Max. magni- tude	Min. magni- tude	Absolute magni- tude	Spec- trum	Mass ☉ = 1	Density $\rho(\text{☉} = 1)$	$P \sqrt{\rho}$
<i>RR</i> Lyrae	0.567	7.16	7.95	-0.3	<i>B</i> 9- <i>F</i> 2	3.7	0.022	0.08
<i>SU</i> Cassiopeiae	1.950	6.05	6.43	-1.2	<i>F</i> 2- <i>F</i> 9	5	0.0032	0.11
Polaris	3.968	2.08	2.17	-1.8	<i>cF</i> 7	8	0.00049	0.09
Delta Cephei	5.366	3.71	4.43	-2.2	<i>F</i> 4- <i>G</i> 6	9	0.0005	0.12
Eta Aquilae	7.176	3.70	4.40	-2.6	<i>F</i> 2- <i>G</i> 9	11	0.0003	0.13
Zeta Geminorum	10.155	3.73	4.10	-3.2	<i>cG</i> 0	15	0.00009	0.10
<i>X</i> Cygni	16.385	6.53	8.09	-3.9	<i>F</i> 8- <i>K</i> 0	19	0.00013	0.19
<i>Y</i> Ophiuchi	17.121	7.17	8.14	-4.0	<i>F</i> 8- <i>G</i> 7	23	0.00005	0.13
<i>I</i> Carinae	35.523	3.6	4.8	-5.1	<i>F</i> 8- <i>K</i> 0	50	0.000008	0.10

The absolute magnitudes, masses, and densities are taken from Eddington's calculations. The apparent magnitudes and spectral types are taken from a compilation by Mrs. Payne-Gaposchkin and S. Gaposchkin.

An important characteristic of the Cepheid class of variables is the relation that exists between their periods and intrinsic luminosities, in the sense that the brighter stars have the longer periods. Miss Leavitt at Harvard discovered this relation in 1910 from her studies of Cepheids in the smaller of the two Magellanic Clouds, the second nearest of the external galaxies. All the stars in the cloud can, to all intents and purposes, be regarded as at the same distance from us; hence the relation between period and brightness observed by her is presumably an intrinsic property of the stars, in the sense that the greater the luminosity of a star, the longer its period. If the Cepheids in the Magellanic Clouds are typical of all, we see that this

period-luminosity law (Figure 67) makes it possible to determine the absolute magnitude and therefore the distance of any Cepheid for which the period is known. This law has had most important consequences in the exploration of the universe.*

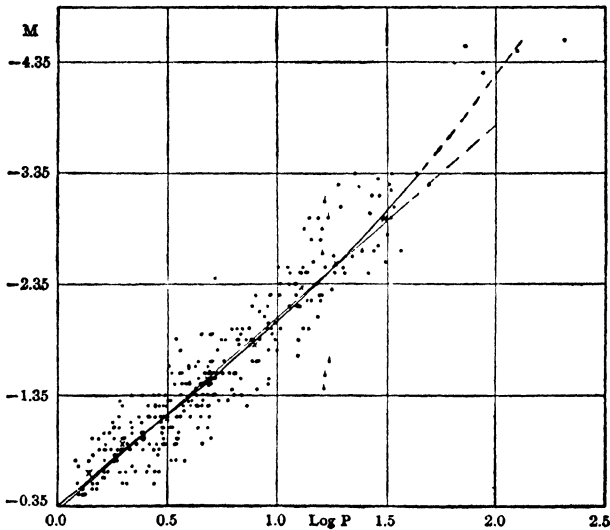

Fig. 67.—The *period-luminosity curve for Cepheids*.

Photographic absolute magnitude is plotted against logarithm of the period (after Shapley).

The Cepheid variables are among the most luminous stars known, and are truly supergiants. Delta Cephei, for example, is on the average about 480 times more luminous than the sun, and has a diameter of about 28 million miles, while ι Carinae is ten thousand times as luminous as the sun. With the aid of the mass-luminosity law (Chapter 1), we may compute the densities given in the eighth column of Table 8, as fractions of the sun's average density. The extremely

* See Bok and Bok, *The Milky Way*, p. 83.

small values are typical of supergiants. A highly significant observation in connection with the theory of Cepheid variation is that the product of the square root of the density and the period, contained in the last column of the table, is very nearly constant. This means that the period of a star whose density is 0.0001 is twice that of a star whose density is 0.0004.

THE PULSATION THEORY

All of the observational evidence we have presented in this chapter seems to favor the hypothesis, proposed by Shapley in 1914, that the Cepheid variables are continually in the process of swelling and

contracting like so many huge balloons. Just what are the conditions inside a star that would enable it to pulsate? We cannot look into the interior of a star, but any conjectures that we make should be guided by the known laws of physics. First of all, the reason why a star does not collapse under its own weight is that its interior is so hot. Although the average density of the sun exceeds that of water, we have good reasons for believing that its interior consists solely of hot, highly compressed



Fig. 68.—Harlow Shapley of Harvard.

gases. The central temperature of the sun must be about twenty million degrees; however, the central temperatures of Cepheids are probably somewhat less than this. Gases at such high temperatures exert a considerable amount of

pressure, due to the impacts of high-speed atoms on the surrounding material. Likewise, the intense radiation that inevitably accompanies temperatures of many millions of degrees also exerts a heavy pressure on matter. Even at a temperature of 6000° , the solar radiation seemingly exercises enough pressure to keep the tails of comets pointing away from the sun. At any point in the inside of a normal star, the combination of radiation pressure plus gas pressure is just enough to support the weight of the overlying stellar layers, just as the compressed air in tires supports the weight of an automobile against gravity.

Let us now suppose that the very neat balance between gravity and pressure is upset, perhaps by the gravitational pull of a passing star, which has the effect of slightly diminishing the weight all along the line joining the stars. When the pressure exerted upon a gas is lessened, the gas expands, just as bubbles rising from the depths of a pond grow larger as they approach the surface. As the heated stellar gases expand, they force the surface layers upward, but only for a time, because an expanding gas grows cooler, and therefore exerts less and less pressure as the speeds of its atoms slacken. When the pressure becomes low enough, gravity reasserts itself, and the expanded layers fall back. Does the star then regain its stability? No, for the momentum of the downward moving gas is usually enough to cause it to overshoot the stable position. Once more the gases become compressed and heated enough to overpower gravity and the sequence is repeated.

The situation is not unlike that which prevails when a weight is suspended from a spring. The spring stretches, and the tension increases until it just compensates for the weight. If we disturb the equilibrium by pulling slightly on the weight and then releasing it, the increased tension in the spring overpowers the force of gravity and the weight

shoots up beyond its original position, until the force of gravity pulls it back. The oscillation that is set up continues until gradually damped out by friction.

The explanation of Cepheid variation as the result of a tug of war inside a star between gas and radiation pressure on the one hand and the force of gravity on the other appears to fit many of the observed features of Cepheid variation. As long ago as 1879 Ritter showed by a reasonable mathematical and physical argument that it was possible for a star to pulsate. But astronomers then knew little about the interpretation of the light curves and nothing about the variable radial velocities of the Cepheids. It was not until 1914 that Shapley showed that the pulsation hypothesis gave the most reasonable explanation of the variability of these stars. Finally Eddington, a few years later, worked out the detailed mathematical theory of Cepheids. He proved that large Cepheids should pulsate more slowly than the smaller denser ones. In mathematical terms, Eddington found that the product of the period and the square root of the average density should be nearly constant. The success of this prediction, as shown in the last column of Table 8, speaks well for the validity of the pulsation theory.

The Eddington theory, however, ran into certain difficulties. It predicted that the star should be brightest when it was smallest because the rise in temperature more than

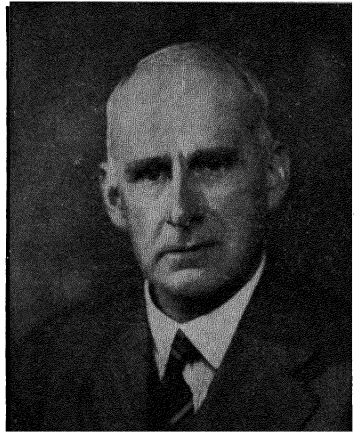

Fig. 69.—Sir Arthur Stanley Eddington of Cambridge.

Photograph by Lafayette, Ltd.

offsets the decrease of surface area. Correspondingly, it should be faintest when largest, and at both maximum and minimum the radial velocity should be zero. However a reference to Figure 66 will show that at maximum and at minimum light the velocity is considerably different from zero. M. Schwarzschild explained this discrepancy by supposing that the whole star does not pulsate in unison; the central portions pulsate synchronously but the outer layers are out of step and we have the phenomenon of compressional waves running outward to the surface. This supposition leads to an excellent agreement between theory and observation. Maximum light comes at time of greatest velocity towards us (largest negative velocity) and minimum light at time of greatest inward velocity. To account for the observed light variation, a change in radius of only a few per cent is necessary.

Eddington pointed out, too, that stars might pulsate in overtones, as well as in their fundamental frequencies, just as a musical string emits notes one, two or three octaves apart, depending on how it is plucked. At the time the theory was formulated no such overtones had been detected in variable stars. But recently T. E. Sterne has suggested that the star Delta Scuti, observed by E. A. Fath, may pulsate not only in its fundamental period, but also in overtones.

SOME UNSOLVED PROBLEMS

The pulsation theory, as we have seen, accounts for many of the facts of Cepheid variation, but the unsolved problems are numerous and knotty. Thus far, at least, theory has not yet accounted for the remarkable relation between period and luminosity. At the University of Michigan, Curtiss and Rufus concluded that the displacements of neutral and ionized lines give different velocity curves.

Since the ionized lines may be presumed to originate at high levels in the atmosphere, where the density is low, and the neutral lines at lower levels, their work suggests that the different layers of the atmosphere are not oscillating in unison.

The very important question of what keeps the star pulsating once it starts is still unsolved. Eddington calculated that the energy of oscillation should gradually become dissipated, and, just as the oscillation of the weight attached to the spring dies out, a normal Cepheid should stop pulsating in a mere few thousand years. Evidently, the loss of mechanical energy due to friction must in some way be replenished from within the star. The alternate compressions and expansions may perhaps modify the rate at which energy is generated in the interior (see Chapter 12).

The short-period cluster-type Cepheids present peculiar problems of their own. Although the average periods, luminosities, and spectra of these objects as a group fall in with the period-luminosity and period-spectrum relationships for the classical Cepheids, the periods, spectra and photographic luminosities of the individual cluster-type Cepheids show no correlation with one other. As M. Schwarzschild has suggested, the clue to the situation may be provided by the fact that the very short-period objects seem to be vibrating exclusively in the first overtone, and not at all in the fundamental frequency. There is evidently some deep and underlying physical difference between these two types of Cepheid variables.

THE RED VARIABLE STARS

The second group of variable stars, those of long period, present even more puzzling problems than do the Cepheids. The stars in this group are all cool, red giants and supergiants, chiefly of spectral classes *M*, *N*, *R* and *S*, radiating

about one hundred times as much energy as the sun, at maximum brightness. Their periods range in general from one hundred to five hundred days and their brightnesses, as observed visually, fluctuate about a hundred-fold, or five magnitudes.

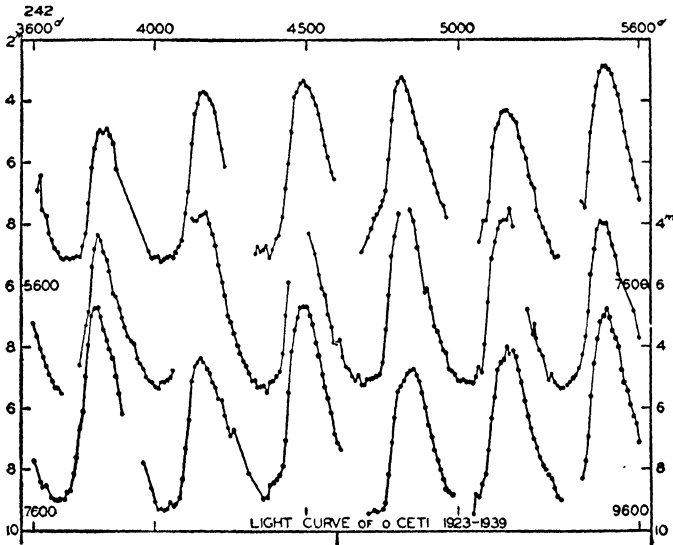

Fig. 70.—The light curve of Mira (omicron) Ceti from 1923 to 1939.

The magnitude is plotted against the Julian Day. (After L. Campbell, reproduced from *Popular Astronomy*.)

In Figure 70 we show the light curve of the brightest and most famous of the red variables, Omicron Ceti, otherwise known as Mira (“The Wonderful”). Notice that, unlike the Cepheid variables, Mira does not always return to the same brightness at maximum, but is nevertheless then easily visible to the naked eye. At minimum, the star becomes so faint, about the ninth magnitude, that it is visible only in the telescope. Like the Cepheids, the long-

period variables seem to exhibit a relation between period and spectrum, in that the stars of longer period are of later spectral type.* Clearly, the long-period variables do not fall on the period-luminosity curve for the Cepheids, since a hypothetical Cepheid of such long period would be much brighter than any known red variable. Mrs. Payne-Gaposchkin finds that the period-density rule characteristic of Cepheids also applies to stars of the Mira Ceti class.

Most of the energy radiated by cool stars is concentrated in the form of invisible heat waves in the infrared region of the spectrum. Pettit and Nicholson, at the Mount Wilson Observatory, have made extensive measures of the energy radiated by the long-period variables with the aid of a *thermocouple*† attached to the 100-inch reflector. They find that at maximum light the temperature of Mira (spectral class *M6*) is 2600° , and at minimum 1900° . Similarly the star *R Leonis* (*M8*) varies from 2200° to 1800° , whereas *Chi Cygni* ranges from 2200° to 1600° . In Chapter 4 we saw that the amount of energy radiated by a star is proportional to the fourth power of its temperature. Since the temperature of Mira changes only by a factor of 1.37, the energy emitted should vary from maximum to minimum by $(1.37)^4$ or 3.5. Yet the amount of variation

* According to the recent discussion by R. E. Wilson, the average long-period *M* or *S* type variable is about 220 times as bright as the sun. He finds the *M* stars of earlier type and shorter period to be at least two magnitudes brighter than those of later types or longer periods, the brightest being about 350 times and the faintest a hundred times the luminosity of the sun. These results indicate that the period-luminosity relation runs opposite to that existing for Cepheids.

† When radiation falls on the junction between two dissimilar metals, e.g., copper and iron, that form part of an electric circuit, electricity is generated, and the amount of the current is proportional to the amount of radiation incident on the junction. Such devices are known as *thermocouples* and are used for measuring heat energy from the cool stars.

shown by the light curve in Figure 70 is over five magnitudes, or more than a factor of one hundred. This apparent anomaly may be partly explained as a consequence both of the difference in shape between energy curves at different temperatures, and of the fact that the light curve of

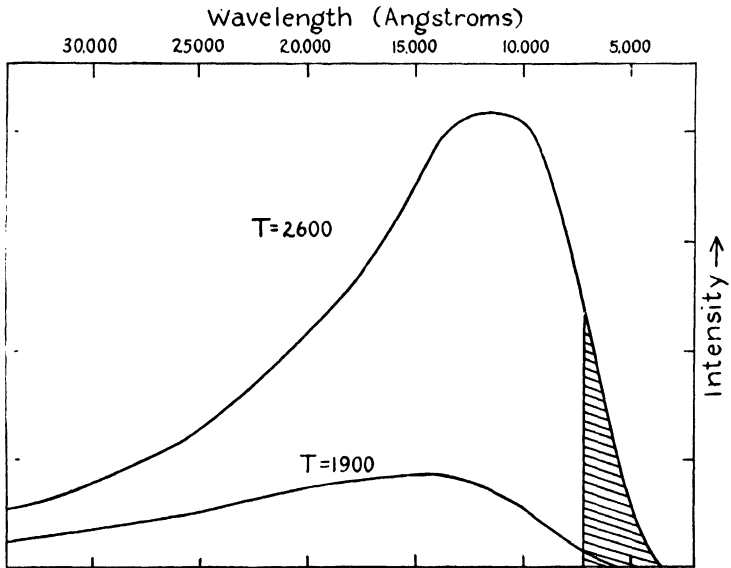

Fig. 71.—Energy curves for 1900° and 2600° K.

The cross-hatched area shows the relative amounts of energy in the region visible to the eye. Notice how the change in visible light is very much greater than the bolometric change (i.e. change in total radiation). Curves such as these were first constructed for long-period variables by Joy.

Figure 70 represents the variation in *visible* light, whereas most of the emitted radiation is invisible to the eye. Figure 71 compares the computed energy curves for Mira at maximum and minimum light. The total radiation, represented by the area under each curve, has increased 3.5 times from minimum to maximum, but the visible radiation, of wave-

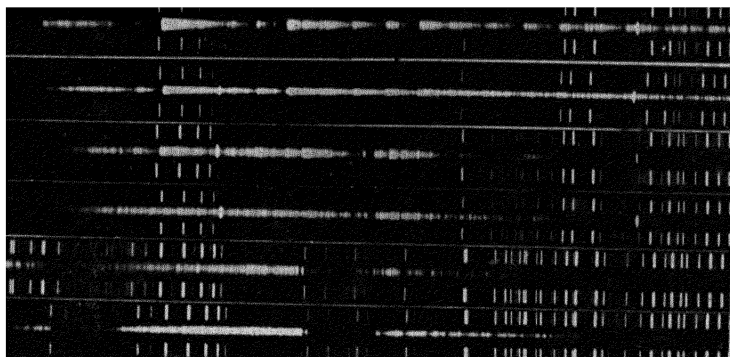

Fig. 72.—The spectra of five long-period variables and 19 Piscium, a red giant.

From top to bottom the variables are

R	Cas	M
R	Boo	M
R	And	S
R	Gem	S
19	Psc	N0
TT	Cyg	N3

The comparison spectrum is shown on both sides of the stellar spectrum in each case (*Photographed at the Mount Wilson Observatory*).

length less than about 8000A, has gone up by a much larger factor. Only part of the discrepancy may be accounted for in this way, however. The change in visual light is still 15 times as large as we would expect. We shall return to this point later.

THE SPECTRA OF LONG-PERIOD VARIABLES

Some representative spectra of long-period variables of classes *M*, *N* and *S* are illustrated in Figure 72, while in Figure 73 we have reproduced one of the beautiful large-scale spectra of Mira photographed at Mount Wilson. We see that all of the spectra are dominated by the bands of various compounds. In Mira Ceti, some of these bands are

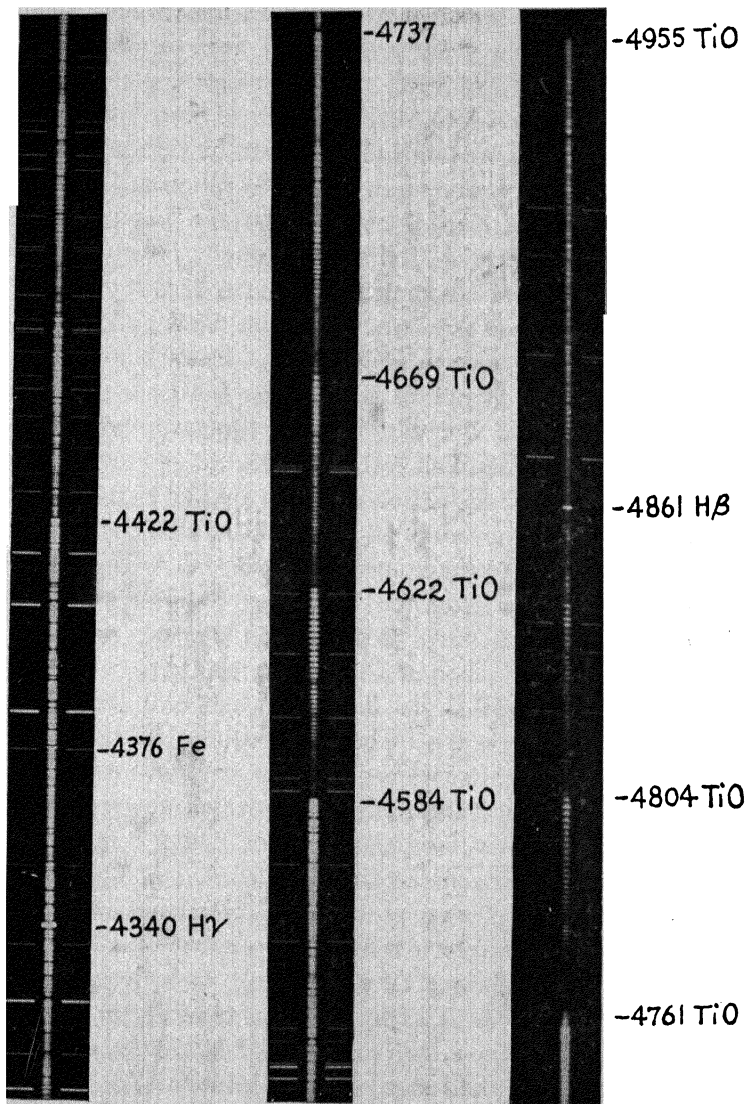

Fig. 73b.—The spectrum of *Mira Ceti*.
(Mount Wilson Observatory)

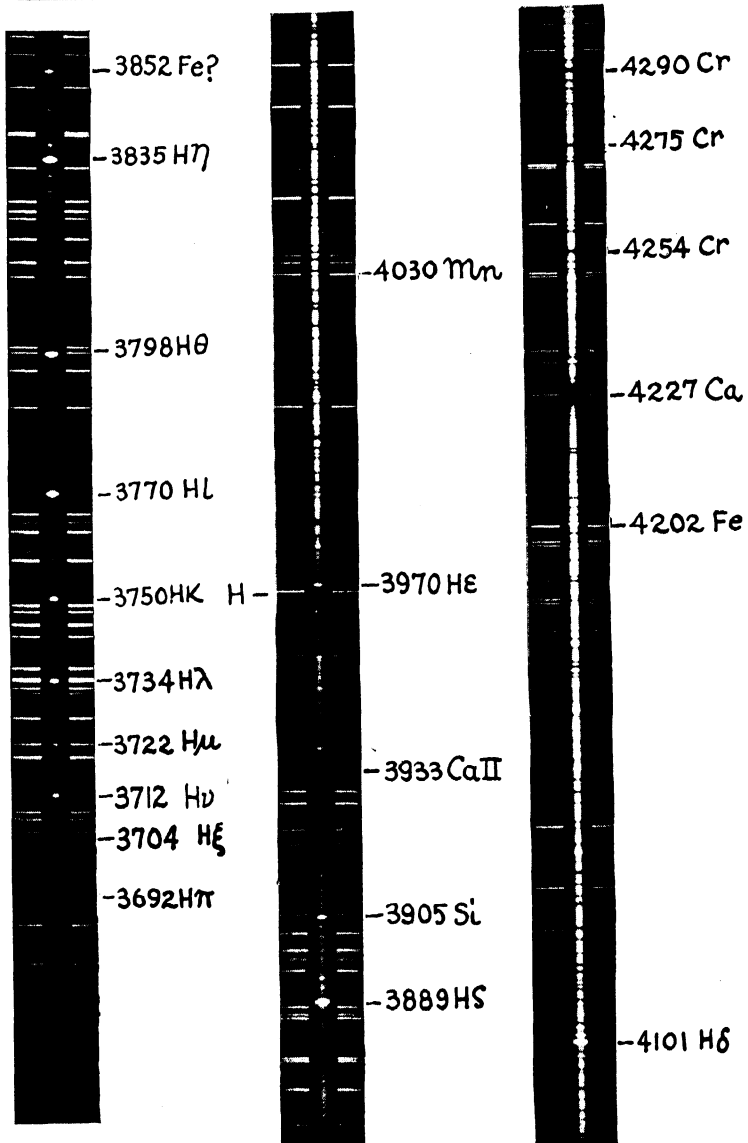

Fig. 73a.—The spectrum of Mira Ceti.

actually resolved into separate lines. In the variable stars of class *M*, only the violet region is free from the obscuring bands of titanium oxide, which produce great gaps in the spectrum from 4600Å to 6400Å. In stars of class *N* the blue and violet regions are largely blotted out, by carbon bands; the blue and violet zirconium oxide absorption in *S*-stars is weak. The absorption is strongest at the band heads, as shown in Figure 73, and then gradually lessens as the separation of band components increases. It is interesting to find that some of the carbon bands in the *R* and *N* stars are produced by molecules containing the carbon isotope of mass 13 (see Chapter 3, p. 45). This isotope is possibly more abundant in the stars than on the earth, where its abundance is 0.7% of all carbon atoms.

The spectra of long-period variables are also rich in dark atomic lines that are normally found at such low temperatures, except when these lines happen to fall in regions of band absorption. Thus the *D* lines of sodium, although quite strong in *S* stars, are smothered by the bands of titanium oxide in class *M*. As the variable star fades and the temperature falls, the dark lines change as we would expect them to on the theory of ionization (Chapter 4). The *H* and *K* lines of ionized calcium fade, and easily excited lines of neutral atoms, e.g., 4227 of calcium, strengthen. Also, at the lower temperatures, additional compounds form and all the bands become intensified.

The most perplexing problem in connection with the spectra of red variables is the appearance, before maximum light, of strong, bright lines, especially of hydrogen (see Figures 72 and 73). The lines appear generally in all red stars that vary,* and the range of their intensities must be far greater than the range of light variation. They reach

* A number of red dwarfs also show hydrogen emission lines.

maximum intensity about a sixth of the period after maximum light. The phenomenon of bright lines in stellar spectra is not unusual, although the great majority of stars do not show them. We discuss the problem in more detail in Chapter 11, where we shall find that bright lines are most likely to occur when a star is very hot and possesses an enormously distended atmosphere. But the red variables, although supergiants with huge atmospheres, are cool objects. Furthermore, the bright hydrogen lines are not radiated by the outermost portions of the atmosphere, but at levels *below* those in which the molecules are absorbing. The evidence for this remarkable behavior comes from an examination of the intensities of the bright hydrogen lines, in Mira and in other variables of class *M*. In laboratory sources, and in the nebulae, the bright lines of the Balmer series diminish regularly in intensity from *H*-Alpha toward shorter wave lengths. But in the *M* stars, whenever a hydrogen line falls within a band of titanium oxide, it is greatly weakened. Thus the first two lines, *H*-Alpha and *H*-Beta, are much fainter than *H*-Gamma, which in turn is not as strong as *H*-Delta. Similarly, the line *H*-Epsilon is weakened by its close proximity to the *H* line of ionized calcium. We can only conclude that the radiations are depleted by the absorption of overlying layers of titanium oxide and ionized calcium.

Although the red variable stars probably expand and contract like the short-period variables, their behavior makes a detailed interpretation on the basis of the pulsation theory extremely difficult. Joy's measurements of the positions of the dark lines and bands in Mira Ceti, for example, show that the velocity varies by about ten kilometers per second, but the velocity curve is identical in shape and phase with the light curve, instead of being a mirror image as in the Cepheids. On the other hand, the velocity curve ob-

tained from the bright lines over the half of the cycle when they are observed, shows the greatest velocity of approach when the lines reach their maximum intensity, which happens shortly after maximum light, similar to the Cepheids. In other words, when the atmospheric layers that produce the dark lines are receding, those responsible for the bright lines are approaching! The average velocity over a period should correspond with the radial velocity of the star in space, but the values obtained from the two sets of lines differ, indicating that the bright-line layer is moving toward us, as compared with the absorbing region.

Further study may lead to a solution of this peculiar velocity anomaly. The answer is probably connected with the fact that the atmospheres of red variables are even more extensive and transparent than those of the Cepheids, so that the spectrum we observe is contributed by regions of widely varying temperatures and densities. The pulsations may well be of such a complicated nature that some strata of gases are rising while others are settling.*

Another important question that is still unanswered is whether changes in temperature and in surface area, as a red variable expands and contracts, are adequate to account for the observed variability of the light. Earlier in our discussion, we saw that the change in visual light for Mira Ceti was about 15 times as great as we would expect from a temperature variation between 2600° and 1900° . It is true that we made no allowance for changes in the

* Recently, R. M. Scott has applied M. Schwarzschild's theory of Cepheid pulsations to the long-period variables. Because the bright hydrogen lines evidently originate at greater depths than the dark lines, he assumed their velocities to be more nearly indicative of the true motion of the star's photosphere. With this very reasonable supposition the pulsation theory may yet be applied with considerable success to the long-period variables.

surface area, but if we do so we merely aggravate the problem, for Pettit and Nicholson concluded that the radii of red variables are on the average 18% greater at minimum light than at maximum. Two possible solutions have been offered. The heavy absorption bands in the visual spectral regions of red stars become even heavier when the temperature is lower and more molecules form. It may be that the increased absorbing power of these molecules at minimum light screens off considerably more photospheric light than at maximum.

A second suggestion has been advanced by Paul W. Merrill, of Mount Wilson, who has studied the spectra of long-period variables more extensively than any other astronomer. Since the atmospheric temperatures are often below the boiling point of refractory substances like carbon,



Fig. 74.—Paul W. Merrill of Mount Wilson.

Merrill suggests that cloudy veils of liquid or solid particles may condense from the gases of the star's upper atmosphere. These particles could conceivably obstruct visual light more effectively than the infrared. Merrill regards the veiling process as a meteorological effect, which, while periodic, because the condensations depend on the temperature, would not be identical during different cycles. He thus accounts for the observed irregularities in the amplitude of the visual light variation.

Red variables are often found to have dense, hot companions, an association that Merrill has referred to as an



Fig. 75.—Nebulosity around R Aquarii.

Photograph (upper) and drawing (lower) from a series of photographs with various exposure times.

(Photographed with the 100-inch Mount Wilson telescope.)

example of “symbiosis” in astronomy. Thus *T Coronae Borealis* is an *M* star associated with an old nova. *Mira Ceti* has a remarkable companion, discovered spectroscopically by Joy in 1923, when the variable was at minimum. The companion, which has since been seen in the telescope by Aitken, resembles a *B* star, but the spectrum shows broad bright hydrogen lines, furrowed in the center by absorption. The bright lines of ionized iron are sharp and weak, whereas those of helium and calcium are 4 or 5Å wide. The *M* star *R Aquarii*, which is immersed in a gaseous nebula (see Figure 75), appears also to have a hot, variable companion of the *P Cygni* type (see Chap. 11), whose spectrum has exhibited radical changes since its discovery in 1922.* The suggestion that the bright lines in *M* variables are induced by radiation from the hot companions does not seem likely, when we recall that the bright lines seem to be produced fairly deep within the star and that all *M* variables do not have hot companions.

To summarize, then, the pulsating stars present a number of fundamental problems. First and foremost: what keeps them going? The long-period variables are particularly troublesome. As with *Zeta Aurigae*, we are at a loss to explain how their enormous atmospheres can remain distended against gravity. How do the bright lines originate? Are the large variations in brightness caused by the condensations of solid or liquid droplets? Finally, how do the variable stars fit into the larger pictures of the origin and evolution of the stars?

* Other objects in which remarkable hot stars are associated with cool, irregular variables are *Z Andromedae*, *AX Persei*, and *CI Cygni*. The latter star, for example, shows emission lines of *FeVII* (i.e. iron with six electrons stripped off!) together with an absorption spectrum corresponding to spectral class *M*. *Z Andromedae* exhibits remarkable spectral changes with variations in excitation and ionization.

8

EXPLODING STARS

THE NOVAE

ON THE EVENING OF JUNE 8, 1918, THE NOTED AMERICAN astronomer, E. E. Barnard, was driving along the countryside in a dejected mood. The spectacle of a clear, starlit sky only added to his dejection, for on that same afternoon cloudiness had thwarted his attempt to observe a total eclipse of the sun. As his eyes wandered aimlessly over the familiar star patterns of the Milky Way, they came to the constellation Aquila. Suddenly aroused, Barnard pointed upwards excitedly and exclaimed: "That star should not be there!" Barnard's startled companions, fearing that his disappointment of the afternoon had unbalanced him, were nonplussed until they realized that he had discovered a nova. Indeed, this new first magnitude star in Aquila was discovered independently by dozens of people on the same night. Older photographic records at some of the observatories showed that on June 5 the star was of the eleventh magnitude, as it had been for the previous 30 years. Forty-eight hours later it was of the 6th magnitude—a 100-fold increase in brightness. Still increasing on June 9, its magnitude was -0.5 , thus outshining all the stars in the sky but Sirius and Canopus. After attaining the peak of its splendor,

the star began to fade, rapidly at first and then more slowly. In eighteen days it had declined to the 3rd magnitude, and it faded from naked-eye view about 200 days later. Its present magnitude is close to the original value before the outburst, but it is still in reality five or six times as luminous as the sun.

Bailey estimated that 25 novae brighter than the 9th magnitude flare up in our galaxy every year but only seven have been conspicuous to the naked eye since the beginning of the century. Before the advent of large telescopes and photography, these flashing intruders were regarded as new stars and even now the designation "Nova" remains in common usage, although photographs show that bright novae such as Nova Aquilae were photographed as faint stars before their outbursts. We now have good reason to believe that a nova is the result of a stupendous stellar explosion. Why the explosion takes place and whether or not all stars have explosive potentialities is still a mystery. We therefore cannot exclude the possibility that the sun may someday become a nova, although the chances of its occurrence are extremely small. The earth could hardly survive such an explosion. So rapidly would the catastrophe proceed that the earth and all of its inhabitants would experience the most precipitous form of sudden death. The entire sunward side of the earth would be burned to a crisp in half an hour, and clouds of live steam from boiled-away oceans would devastate the night hemisphere even before the rotation of the earth exposed it to the sun. Within a few days, great clouds of metallic vapors would be ejected from the sun, to envelop and vaporize the earth. The only remaining trace of our earth would be a tiny condensation in a rapidly expanding shell of gas.

The explosion of a star must be merely the symptom of a more deep-seated disturbance. We visualize a star as a

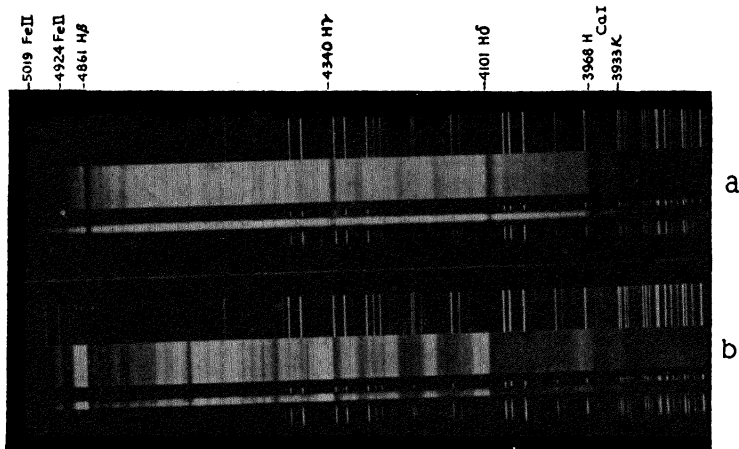

Fig. 76a, b.—The spectrum of Nova Cygni (1920).

The upper spectrum was obtained August 24.76 and the lower spectrum August 28.80. Note the conspicuous changes that have taken place in four days. (*Spectra obtained at the Lick Observatory.*)

great mass of intensely heated gas in which energy is created in the deep interior and slowly bubbles to the surface. As we saw in Chapter 7, at any point in the interior of a normal star the weight of the overlying material is just balanced by the pressure of gas and radiation. We saw that as the temperature of a gas rises, the pressure also rises, because the gas tries to expand. This fact is familiar to every motorist who removes some of the air from his tires on a hot day. For he knows that otherwise the expanding gas may burst the tire walls. Let us suppose now that, due to some sudden liberation of energy, the gas somewhere inside the star becomes overheated. If the star does not have a safety valve by means of which some of the excess energy may escape, the mounting pressure of the expanding gas may so overbalance the weight of the material above it that the entire upper layers of the star will be violently ejected into space.

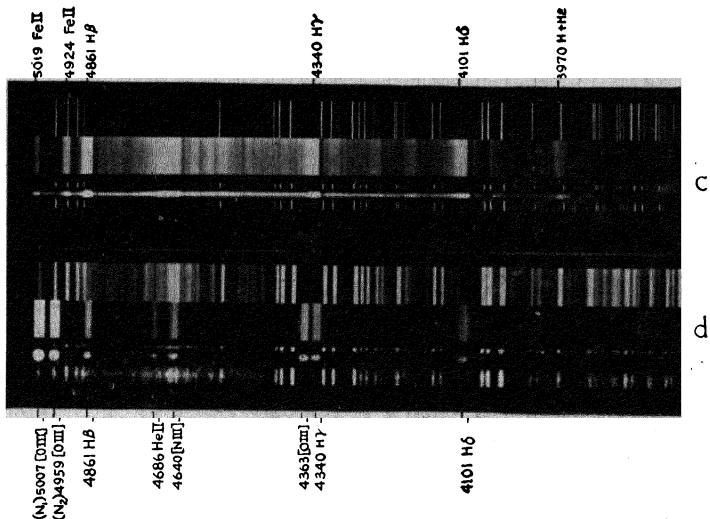

Fig. 76c, d.—The spectrum of Nova Cygni (1920).

The upper spectrum was taken September 18.91 1920; the lower plate some two years later on September 1.8 1922 when the nova had declined considerably in brightness. The narrow spectra are from direct enlargements of the original plates, the wider spectra have been artificially broadened. Exposure *d* was taken on a fast grainy film, as the star was very faint at that time. (*Lick Observatory*.)

The idea that novae are the result of explosions in steady stars has been inferred from the remarkable spectral changes that accompany such outbursts. A good example of a more or less typical nova is Nova Cygni (1920) whose brightness soared from the 15th to the 2nd magnitude during the course of a few days. A series of spectra of this temporary star, obtained at the Lick Observatory, is reproduced in Figure 76, together with a curve showing the variation in light (Figure 77). During the early stages of a nova's life, the stellar surface swells up like a balloon. As the star grows larger, it becomes brighter. At maximum light (see strip *a*) the spectrum is continuous and crossed by dark lines as it

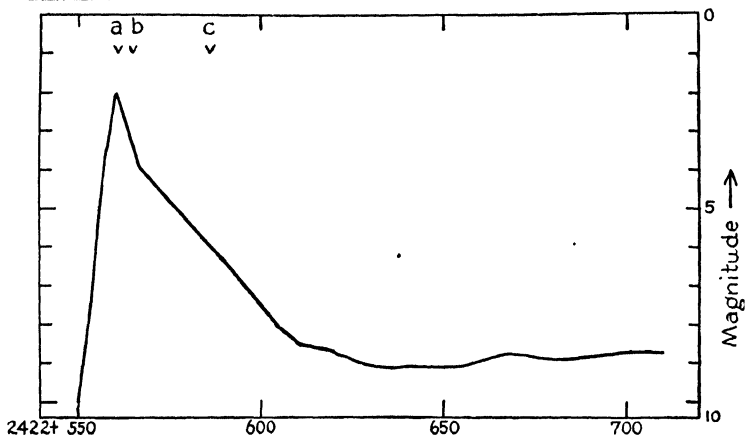

Fig. 77.—The light curve of *Nova Cygni* (1920).

The arrows indicate the dates of the Lick observations reproduced in Figure 76. Magnitude is plotted against Julian Day. (After L. Campbell.)

was before and during the rise of brightness. Evidently the photosphere, although enormously expanded, is still intact. The dark lines of hydrogen and of ionized calcium, iron and titanium are produced in that portion of the atmosphere which is between the stellar surface and the observer. While the star is expanding rapidly, the atmospheric atoms in the line of sight are in rapid motion towards the observer (see Figure 78). Consequently, the absorption lines are shifted to the violet of their normal positions by the Doppler effect; from the magnitude of the shift, we are able to deduce the rate of expansion. Expansion speeds of 1000 kilometers per second are not uncommon.

The swelling of the photosphere is probably accompanied by the ejection of an expanding atmospheric shell from the star. As the gaseous shell expands, it soon becomes much larger than the star and highly rarefied. Under these circumstances, the continuous spectrum fades and bright lines begin to appear. (See Figure 76*b* and *c*.) The star itself

continues to emit a continuous spectrum. But the light from all parts of the expanding shell that do not lie between the star and the observer will consist of bright lines. The arrows in Figure 78 mark the direction of motion of atoms in different regions of the expanding envelope. The atoms at points *B* and *H* are moving towards the observer; their

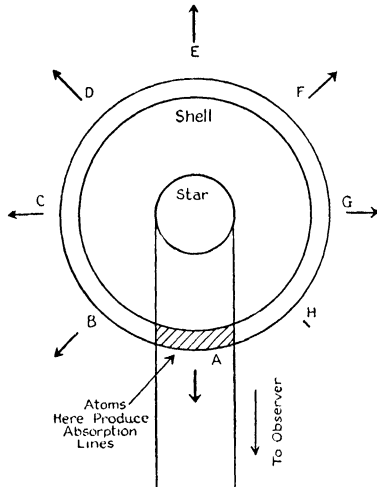

Fig. 78.—Schematic diagram of an expanding shell about a nova.

The arrows indicate the directions in which the various parts of the shell are moving. Only the atoms in the cross-hatched part of the shell are between the star and the observer and produce absorption lines.

lines will, consequently, be shifted towards the violet. At points *C* and *G* the motion is at right angles to the line of sight and the Doppler shift is zero. At *D* and *F* the atoms are receding and the bright lines from these regions of the shell will be displaced redward. Summing up the contributions from different parts of the shell we find that the net effect of the expansion is to broaden out the emission lines (Figure 76). At the same time the material at *A* absorbs light from the continuous spectrum of the star, thus pro-

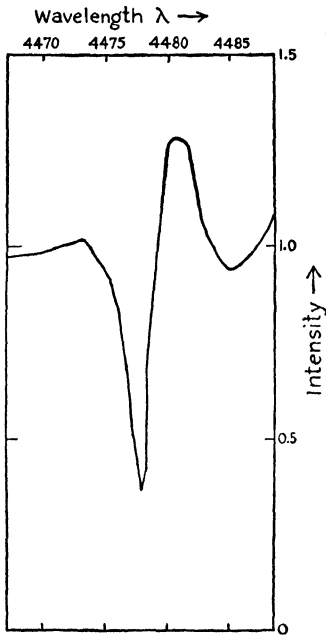

Fig. 79.—The observed profile of the 4481 MgII line in the spectrum of Nova Herculis (1934).

Intensity is plotted against wave-length; the intensity of continuous spectrum is taken as 1.0. Notice that the absorption component of the line (to the left) is much stronger than the emission component. Evidently the volume of gas absorbing the λ 4481 radiation in the line of sight is somewhat greater than the volume emitting this line in other parts of the shell. (From a plate taken December 15, 1934 at the Lick Observatory.)

ducing a series of dark lines. Since the atoms at A are approaching the observer, the dark lines will appear displaced to the violet of the emission line. It is interesting to note from Figure 76c that each dark line of hydrogen consists of several components. Evidently several separate shells of material were ejected from the star, each with a different velocity. In Figure 79 we display the observed profile of the 4481 line of ionized magnesium in Nova Herculis (1934).

As the gas expands further, the bright lines of the metals become progressively weaker, while those of the light gases like hydrogen, nitrogen and oxygen remain prominent. This phenomenon is easily explained. The outer electrons of the metals are not too tightly bound to their respective atoms and are easily torn away. When the density is high, the separation between atom and electron is only shortlived. But in the tenuous condition of a nova's shell, an electron once lost is not easily replaced; the metallic atoms tend to lose not one but many electrons, and multiply-

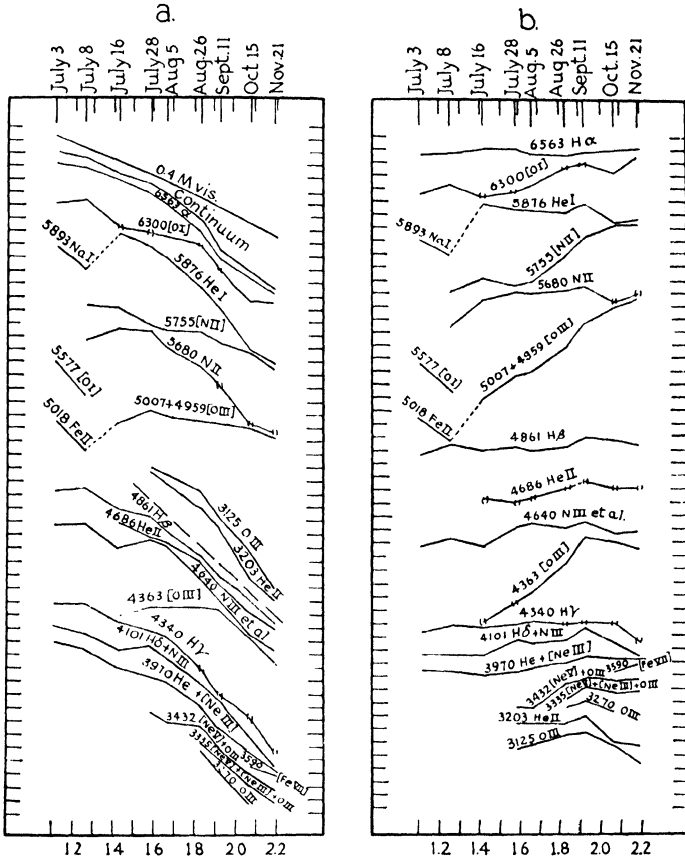

Fig. 80.—The variation of line intensities in Nova Lacertae.

The curves in (a) show how the total intensities of emission lines vary with the time. Logarithm of intensity is plotted against the logarithm of the time interval (t^d —June 20), i.e. the logarithm of the interval in days after June 20, 1936. Each division equals 0.2 in log intensity and the separate curves have been shifted up and down arbitrarily to prevent confusing overlapping of curves. Notice how the metallic lines disappear rapidly and the lines of the permanent gases persist much longer, particularly the nebular lines 5007 and 4959 of [OIII]. In (b) the intensity relative to the continuous spectrum is plotted. (*Astrophysical Journal*, after D. M. Popper.)

ionized atoms usually radiate light only in the inaccessible far ultraviolet region of the spectrum. On the other hand, the light gases are much more difficult to ionize; hence their radiations persist long after those of the metals have vanished. In a later stage of nova development, Figure 76*d*, the most prominent lines are the green, so-called "nebular" lines, which are characteristic of the spectra of planetary nebulae. We shall find in Chapter 9 that the appearance

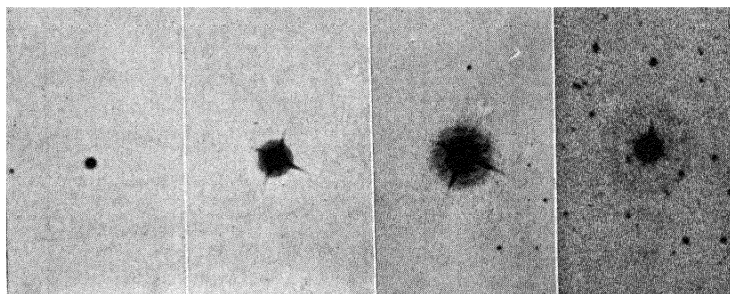

Fig. 81.—Development of the shell about Nova Aquilae.

From left to right successive pictures were taken in 1922, 1927, 1933, and 1940; the last picture was taken in the light of $H\alpha$ (the red hydrogen line), as the nebulosity was too faint to be seen in photographic light. (*Mount Wilson Observatory.*)

of these lines indicates a temperature of about $10,000^\circ$ and a density a million million times less than that of the air we breathe. At this stage the continuous spectrum of the star has almost disappeared, and only the emission lines remain. We do not mean to imply that the continuous spectrum does not exist, only that the bright lines are overpoweringly stronger. Eventually, after the disturbance has subsided, the gaseous shell dissipates away, to contribute to the debris of interstellar space. After some years, the star settles down almost to its pre-outburst state, the nebular spectrum vanishes, and the continuous spectrum

of the star reappears. D. M. Popper's careful photometry of Nova Lacertae (1936) shows (Figure 80) how the spectral lines vary both in absolute intensity and with respect to the continuous background.

The spectroscopic evidence that novae do indeed cast off shells of gas has been confirmed by direct observations of Nova Persei (1901) and Nova Aquilae (1918). Six months after the latter's outburst, a faint, greenish envelope could be seen in the telescope; since that time the shell has been expanding uniformly at the rate of about two seconds of arc per year, as the four photographs shown in Figure 81 will attest. Although the shell ejected by Nova Aquilae appears perfectly spherical,* that due to Nova Persei is peculiarly unsymmetrical, as though most of the material came from a single hemisphere (Figure 82).

The existence of expanding shells aids in the determination of the distances of novae. By Doppler's principle, we obtain the actual rate of expansion in kilometers per second from measures of the spectral-line displacements. If we now observe the apparent rate of expansion, in seconds of arc per year, from the direct photographs, we may compute the distance. The values obtained in this way for Nova Aquilae and Nova Persei are about 1200 and 2000 light years, respectively.

Most novae appear to behave in a remarkably similar fashion, the chief difference being one of speed of expansion

* In Nova Persei yet another type of phenomenon appeared. After the outburst, there were seen diffuse, irregular clouds, of rapidly changing form, not far from the star. The interpretation of this feature is that the light of the nova illuminated surrounding masses of interstellar gas and dust. The rate of illumination of these clouds gave a distance estimate of 400 light years, in contrast to the determination of a distance of two thousand light years by the method of the expanding shell. It has been shown, particularly by Oort, that the latter method is the more reliable.

and of light change. Thus one hundred days elapsed before Nova Herculis fell three magnitudes below maximum brightness. Nova Aquilae (1918) and Nova Cygni (1920) diminished in brightness by the same factor after only 8 and 16 days, respectively. From a careful study of the seven bright novae that have thus far appeared in the 20th

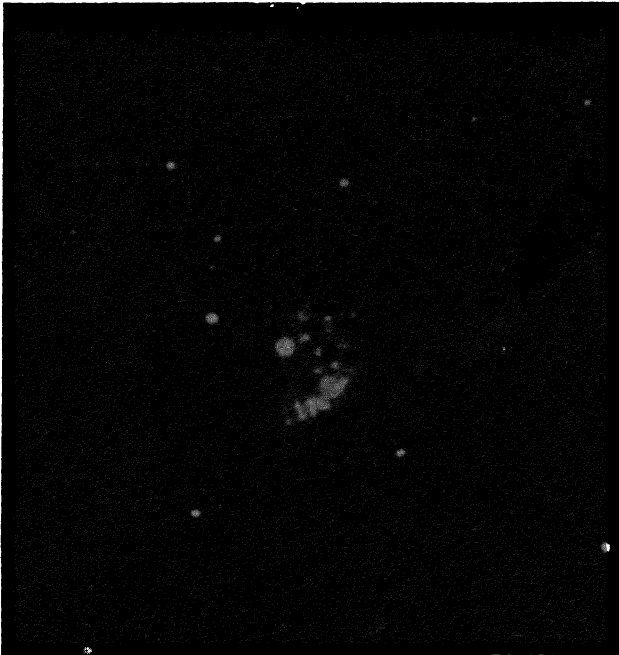

Fig. 82.—Nebulosity about Nova Persei (1901).

Photographed by Baade December 13, 1939. (Mount Wilson Observatory.)

century, D. B. McLaughlin, of Michigan, showed that those novae for which the light faded more slowly had lower initial expansion velocities, and showed longer time intervals between the various spectroscopic phases that we have described above. He emphasizes that novae are similar

regardless of the rate of development: "Speculating a little more freely, the fact that we can express the rate of development in terms of a single parameter—the velocity—suggests that the phenomenon of a nova is due to a single sudden release of energy within the star. The great explosion represented by the rise to maximum light determines completely the train of events which follows during months or years afterward, just as the trajectories of the fragments of a bursting bomb are determined at the instant of the explosion. Whatever differences we observe between the spectra of novae having equal rates of development would then depend upon chance irregularities in the density of the ejected matter, on the composition and degree of turbulence of the gases, and on the orientation of the main erupted masses with respect to the line of sight."

Novae frequently remain variable for years after the original outburst. In fact, some novae, or nova-like objects, have been recurrent. *RS Ophiuchi* has had two outbursts, in 1898 and 1933, and *U Scorpii* has suffered three. The ranges in brightness were respectively 1600 and 600-fold, considerably less than the 100,000-fold variation in ordinary novae. The tendency to become a nova may be a chronic ailment of certain types of stars, and all novae may be repeaters with periods of millions of years. Is the sun likely to be afflicted with nova-itis? The question could be

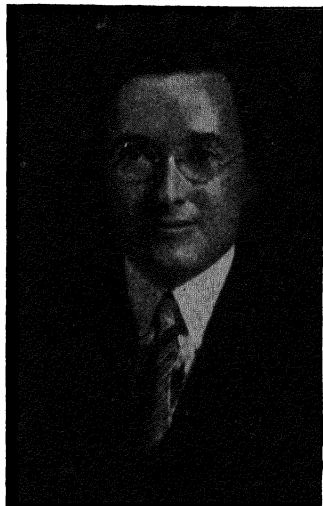

Fig. 83.—Dean B. McLaughlin of the University of Michigan.

answered more definitely if the spectra of a great many novae had been studied before outburst. The spectrum of Nova Aquilae (1918) appears to have been of spectral class near *A*. At present it seems probable that novae originate from dense, white stars. Theoretical studies indicate that below the surfaces of these stars there may exist a zone of instability in which the equilibrium between gas and radiation pressure and gravity may be delicate. Slight disturbances are capable of upsetting this equilibrium and causing violent upheavals in the surface layers of the star.

Ultimately, novae seem to develop into small, intensely hot stars of presumably high density. M. L. Humason of Mount Wilson has investigated the present state of sixteen old novae. The study included Nova Persei (1901), Nova Aquilae (1918) and Nova Cygni (1920). He finds them to be among the bluest of stars, comparable in temperature to the *O* and *B* stars. Most of them display continuous spectra from which all lines have faded.

Humason finds the present absolute magnitudes of Nova Persei and Nova Aquilae to be 4.1 and 3.0 respectively, from their present apparent brightnesses and the distances determined from the expanding shells around them. From the true brightnesses of these stars, and their temperatures, it is possible to calculate the actual sizes they must have at present. The temperatures are not known exactly but are similar to those of the *O* stars. The masses are unknown; Humason has guessed them to be 1.0 and 1.5, respectively. These are likely values if the novae were normal stars before the outburst. These calculations suggest that the present diameter of Nova Persei is about a sixth that of the sun and its density is about two hundred times greater than the sun's density, i.e., about 300 times that of water. The diameter of Nova Aquilae is now about a fourth that of the sun, and its density is about seventy times as great.

McLaughlin points out that ex-novae are small, hot stars, with luminosities, radii and densities intermediate between those of main-sequence stars and true white dwarfs. He suggests, as a working hypothesis, that novae, before outburst, are practically identical in character with the objects observed after the nova stage is past. A nova is to be regarded as a special type of star, physically different from others, which may possibly repeat its outburst in intervals of thousands of years.

THE SUPERNOVAE

In August 1885, a new star suddenly appeared near the center of the Andromeda Nebula, attaining a brilliancy about a tenth the luminosity of that whole galaxy. It reached the sixth magnitude, declined ten-thousandfold in brilliance in six months, and then disappeared. Its position in the nebula and its spectrum, which was not like that of ordinary novae, indicated that this was not a foreground star. Similar objects, attaining luminosities comparable with that of the nebula in which they appear, have been detected in other and more distant spirals.

In 1917, Ritchey found two novae upon photographs of the Andromeda Nebula, but these were thousands of times fainter than the 1885 object. Subsequent studies by Hubble at Mount Wilson Observatory showed that every year there appear twenty-five or thirty novae in the Andromeda Nebula, which at maximum never become brighter than the fifteenth magnitude. These novae are mere pygmies beside the spectacular object of 1885. Now, if these fainter objects are assumed to be similar to the novae found in the Milky Way, the Andromeda nebula would be nearly a million light years away and comparable to our own galaxy, but if the bright object of 1885 is assumed to be a typical nova, the system would be very near and small in size.

The question was finally settled by Hubble's identification of Cepheid variables in the Andromeda Nebula, which showed that it and other spirals were truly external galaxies and that the nova of 1885 was an object of unusual type. Stars like the 1885 nova, which reach luminosities comparable with those of the galaxies that contain them, are generally called *supernovae*. In recent years many of these objects have been discovered in external galaxies. Zwicky

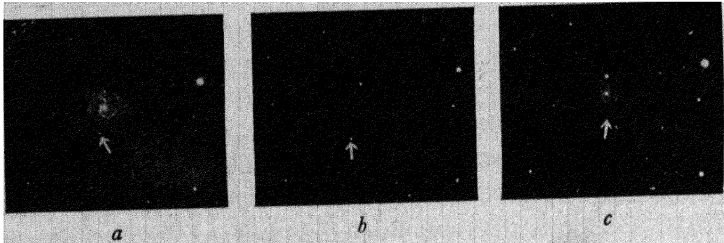

Fig. 84.—Three supernovae in NGC 3184.

a. December 1937. (Harvard.) b. December 1921. (Harvard.) c. April 1921. (Mount Wilson.)

estimates that on the average the flare-up of a supernova is likely to occur in each galaxy once every six hundred years, although one galaxy is known in which three such outbursts have occurred, two in 1921, and one in 1937 (see Figure 84). The tremendous luminosity of supernovae is best illustrated by the middle photograph, which shows the object to be even brighter than the entire galaxy of stars.

The typical light curve of a supernova is shown in Figure 85. These stars, at maximum, are normally ten to a hundred million times as bright as the sun. They fade in much the same way as an ordinary nova. Whipple and Mrs. Payne-Gaposchkin estimate that near maximum light the effective temperatures of supernovae are relatively low (about $10,000^{\circ}\text{K}.$). To radiate as much light as they do, super-

novae must swell up to gigantic proportions, probably many times larger than the orbit of the earth. It seems probable that, as in a nova, a supernova results from a star "blowing its top off." The operation, however, occurs on a much more prodigious scale. Whereas in the usual nova the velocity of ejection amounts to a few hundred kilometers per second, the material from a supernova must be thrown out at a rate of at least 5000 kilometers per second.

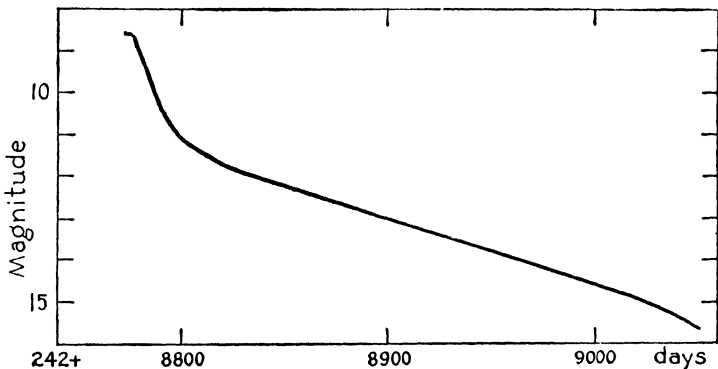

Fig. 85.—The light curve of the supernova in I.C. 4182.

(After D. Hoffleit.)

Recently, Minkowski has recognised the existence of two types of supernovae. Those of his Type *I* attain a brilliance of about a hundred million times that of the sun, while those of Type *II* reach luminosities of about ten million times that of the sun. The Type *I* supernova in I.C. 4182 attained at maximum a luminosity of about 600 million suns, becoming nearly a hundred times as bright as the galaxy that contained it. Baade found that within two years this star had faded beyond the reach of our telescopes. Supernovae of Type *I* fade rapidly, but those of Type *II* fade slowly at first and then rapidly, so that their light curves show a shoulder effect.

To attempt to learn anything from the spectrum of a supernova seems at first sight a hopeless task (Figure 86). R. Minkowski, who has made a thorough study of supernovae spectra, finds that they consist entirely of a few ill-defined broad bright bands, with no trace of sharp lines, except for two of the so-called *forbidden* lines of neutral oxygen atoms (see Chapter 8) at 6300 and 6363A, which appear at a late phase. The bands are broader and the excitation is evidently higher in Type *I* than in Type *II*.

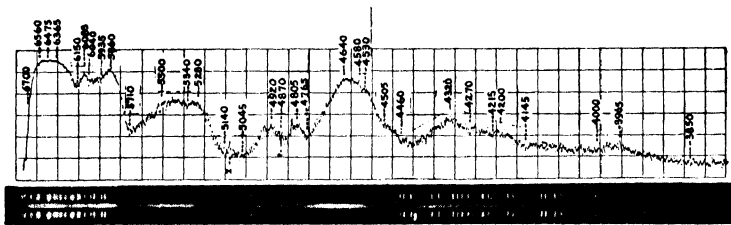

Fig. 86.—Spectrum of the supernova I.C. 4182.

Photographed by Minkowski on September 10, 1937. The spectrum and the microphotometer tracing which registers the degree of blackening on the original negative are shown side by side. Notice that there are no sharp lines in the spectrum. (*Mount Wilson Observatory.*)

These spectra have, however, been given an ingenious interpretation by F. L. Whipple and Mrs. C. H. P. Gaposchkin, at Harvard, who suggest that the spectra of supernovae are very similar to those of ordinary novae, except that the enormous velocity of expansion in supernovae so widens the individual bright lines, that they overlap with each other to form an effective continuum. To strengthen the argument, these investigators have constructed sets of so-called "synthetic" spectra, calculating how the spectrum of a supernova would appear, if its atmosphere contained various mixtures of elements such as helium, carbon, oxygen, nitrogen, and iron in various stages of ionization and excitation, and were in a state

of rapid expansion. Their synthetic spectra bear a remarkable resemblance to those observed in Type *II*. The spectra of Type *I* are not well explained.

An interesting result of their study was that the hydrogen lines must be much weaker than in ordinary stars, although helium and iron are very prominent. Present theories of stellar energy generation (see Chapter 12) suggest that hydrogen in the interior is being steadily converted into helium. Consequently, we might expect to find, inside certain stars, large quantities of helium and the heavier elements, and relatively little hydrogen. It seems likely that the disturbance responsible for supernovae is so deep-seated that material from the far interior of the star is ejected, which would account for its unusual chemical composition.

The origin of supernovae is still obscure. Whipple has made the interesting suggestion that collisions between two stars may be responsible, a mechanism that had been proposed many years ago to account for ordinary novae. The resulting catastrophe would be stupendous. As the two stars approached each other, great tides would be raised, resembling the great clouds of gas (prominences) ejected from the sun. The impact of one star upon another would create enough compression to raise the temperature in the interiors by a large amount. The effect of the raised temperature inside would be to increase the pressure of gas and radiation enough to drive away the upper regions of the star with tremendous speed. Some of the matter would escape from the gravitational control of either star, and some would fall back to the surface.

THE CRAB NEBULA

Two or perhaps three supernovae have possibly been observed in our own galaxy. In 1572, Tycho Brahe ob-

served a star that outshone Venus and was easily visible in full daylight. Another possible supernova was the star observed in 1604 by Kepler. Probably also the object shown in Figure 87 was once a supernova. The Crab Nebula, a



Fig. 87.—The Crab Nebula.

(Jan. 5, 1938 with the Crossley Reflector of the Lick Observatory by N. U. Mayall.)

slowly expanding, luminous cloud of gas, was so named by Lord Rosse, who made a remarkable drawing of it as seen in his telescope nearly a century ago. Photographs made at intervals of ten or twenty years now reveal that the object

is slowly expanding, like the shells around Nova Aquilae and Nova Persei. J. C. Duncan's measurements suggest that the mass has expanded from a single origin, probably an exploding star, and that the outburst would have

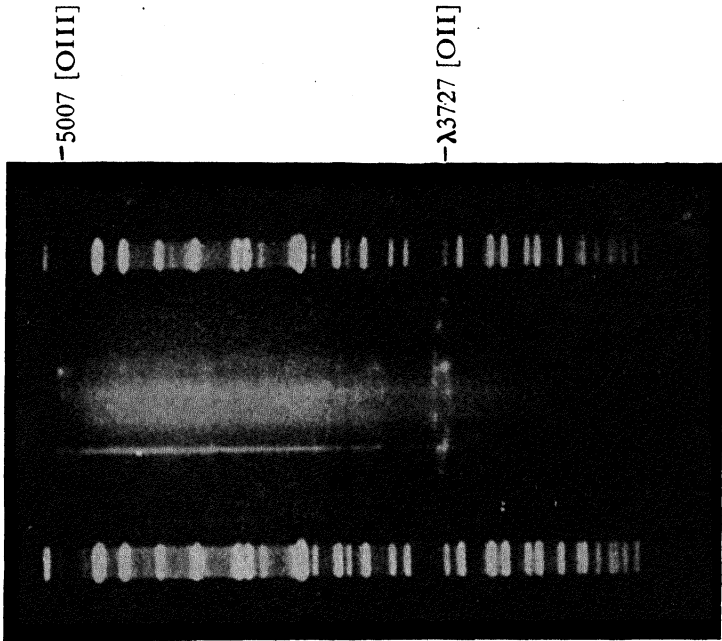

Fig. 88.—The spectrum of the Crab Nebula.

Notice the strong continuous spectrum and the bright bow-shaped lines of oxygen at λ 3727. (From a spectrogram taken by N. U. Mayall with the Crossley Reflector of the Lick Observatory.)

been observed from the earth approximately 900 years ago. This date is important because in the year 1054 an anonymous Chinese astronomer noted a bright star in the same part of the sky. It was also noticed by an anonymous Japanese, who remarked that it seemed as luminous as Jupiter.

Spectrographic observations have yielded valuable information on the expansion of the Crab nebula.* A spectrogram obtained by N. U. Mayall at the Lick Observatory is shown in Figure 88. The slit of the spectrograph is placed along a diameter of the nebula. Notice that the strong 3727 line is bow shaped. This effect is just what we would expect in an expanding shell of gas. At the center of the nebular "disk," the gas on the side towards us is rushing in our direction and the line is shifted towards the violet, while the material on the opposite side is moving away and the line is shifted redward. Hence the spectral line appears split in the central regions of the nebula. At the edges of the nebula, the material is moving across the line of sight, and the line-of-sight speed of the expanding shell is zero; hence the shift of the spectral line is zero here. Now the maximum separation of the two components of the line is proportional to twice the speed of expansion of the shell in kilometers per second. On the other hand, measures on direct photographs give the apparent (angular) rate of expansion in seconds of arc per year. Clearly, if we know the actual speed of expansion in kilometers/year, and the angular speed of expansion in seconds of arc per year, we can calculate the parallax. In this manner, Mayall estimated the distance of the Crab Nebula to be about five thousand light years. If the estimate of brightness of the Japanese astronomer is correct, the star must have been many times as bright as an ordinary nova, and hence probably a supernova.

* Baade finds that the filaments give the bright-line spectrum and the diffuse nebulosity a continuous spectrum that contributes 80% of the light. Minkowski finds the nebula to be about 15 times as massive as the sun and to have an electron temperature of 50,000°. The temperature of the central star is of the order of 500,000°, its radius is about 0.02 and its luminosity 30,000 times that of the sun.

THE PLANETARY NEBULAE

*I*N "THE TALISMAN," SIR WALTER SCOTT RELATES THE conversation between a Christian knight and a Saracen, whom he had met in the desert during a truce. The latter commented on how poorly the knight's charger was suited to the desert, how the creature's hoofs sank deeply into the sand, so that he moved only with the greatest effort. To this jibe the European retorted that he had been able to ride his horse across a sizable lake without wetting more than his horse's hoofs. Now the Saracen knew that a person could float in the Dead Sea without danger of sinking, but the idea of a hard surface on a lake, upon which a man and horse could ride, was too much for one who considered himself well acquainted with the idiosyncrasies of so familiar a substance as water. We need hardly add that the Saracen regarded the knight as a highly imaginative liar.

From our experiences on the earth and in the atmospheres of stars, we may believe ourselves well acquainted with the behavior of matter, for atoms seem to emit the same radiations everywhere in the universe. For example, the *H* and *K* lines of ionized calcium have been observed in the laboratory, the sun, stars, clusters, and even in external

galaxies a hundred million light years away. But a familiar atom may sometimes register under an unfamiliar signature, and radiate lines never before observed in terrestrial laboratories. Thus, like the Saracen who had never seen ice, we may be led astray, as were astronomers who first studied the bright-line spectra of *planetary nebulae*.

THE PHYSICAL NATURE OF THE PLANETARY NEBULAE

Early observers, scanning the sky with their small telescopes and making catalogues of the interesting celestial objects, were occasionally startled to find small disk-shaped formations that appeared not unlike the images of Uranus or Neptune. The objects were definitely not planets, as their lack of motion showed, but the distinctive name of planetary nebulae was eventually assigned to them by Sir William Herschel. Many of them have since been found to contain a very blue, and therefore presumably very hot, star near the center. Astronomers later proved that the light emitted by the nebulous shell took its origin in the nuclear star. This star appears to emit very large quantities of ultraviolet radiation which, after absorption by the nebular atoms, gives rise to the observed emission of light. The complicated physical processes involved have been widely studied, in attempts to analyze and interpret the spectra of the planetary nebulae, which were first investigated thoroughly by W. H. Wright about 25 years ago. His pioneer work on the wave-lengths and intensities of the nebular lines made possible the later theoretical advances.

Some drawings made from photographs of planetary nebulae are reproduced in Figure 89. NGC 7662* has a

* Most bright nebulae and clusters are designated by the numbers given them in Dreyer's New General Catalogue, abbreviated NGC, or in his Index Catalogue, abbreviated IC, or in Messier's Catalogue, abbreviated M.

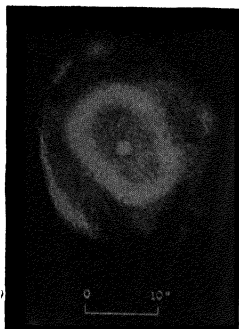

Fig. 89a.—The planetary nebula NGC 7662.

(A drawing by H. D. Curtis from plates taken at the Lick Observatory.)

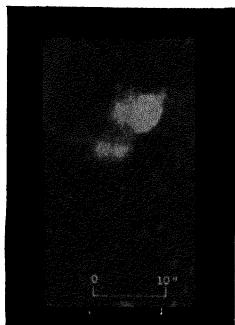

Fig. 89b.—The planetary nebula NGC 7027.

(A drawing by H. D. Curtis from plates taken at the Lick Observatory.)

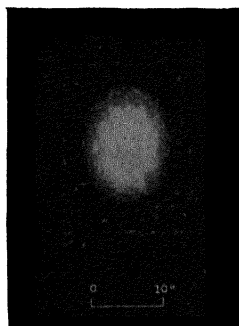

Fig. 89c.—The planetary nebula NGC 6572.

(A drawing by H. D. Curtis from plates taken at the Lick Observatory.)

double ring, a bright inner one and a faint outer one, illuminated by a very blue central star; NGC 7027 is of the irregular type, its central star, one of the hottest objects in the universe, shining at a temperature of about 100,000°.



Fig. 90.—The “eight-burst” planetary.

(Photographed at the Boyden station of the Harvard Observatory.)

The so-called “8-burst planetary,” NGC 3132, illustrates the intricate structure sometimes exhibited by these gaseous nebulae.

From the best evidence available, the planetaries are among the most distant objects in our Galaxy. Most of the known ones lie between 3000 and 30,000 light years away.

They are by no means uniform in size, but the typical bright planetary has a diameter of the order of a million million miles, more than ten thousand times the distance from earth to sun (see Table 9). Yet the total mass of a

TABLE 9
DIMENSIONS, TEMPERATURES, AND DENSITIES OF PLANETARY NEBULAE

<i>Object</i>	<i>Distance (parsecs)</i>	<i>Radius (astron. units)</i>	<i>Tempera- ture (absolute scale)</i>	<i>Density (atoms per cm.³)</i>	<i>Mass (lower limit, ☉ = 1)</i>
NGC 7027 . . .	2,130	10,600	9,500°	5.4×10^3	0.07
NGC 6572 . . .	1,230	8,600	9,200	10	0.07
NGC 6826 . . .	1,050	13,600	7,200	4.0	0.12
NGC 6543 . . .	1,080	10,800	6,000	10.4	0.07
I.C. 418 . . .	1,800	10,800	6,800	7	0.05
NGC 7662 . . .	1,200	10,000	10,300	11.5	0.06
NGC 7009 . . .	930	8,400	9,500	19	0.08
NGC 1535 . . .	1,720	15,500	10,000	7.5	0.21

planetary is probably less than one fifth the mass of the sun. These bodies are therefore great, glowing vacua, thousands of times rarer than the best vacuum attainable on the earth.

Recent work by Bowen and Wyse at the Lick Observa- tory has shown that the chemical composition of certain typical planetary nebulae does not differ significantly from that of an ordinary star like the sun. The permanent gases, hydrogen, oxygen, nitrogen, and even neon (a rare gas terrestrially) are very abundant, and the metals are present in small amounts. Some idea of the nature and tenuity of a planetary nebula may be gained from the following illustration. Imagine an ordinary drinking glass filled with hydrogen gas at room temperature and atmospheric pres- ure. Add half a thimbleful of ordinary air and a few dust particles to provide some metallic atoms and other im-

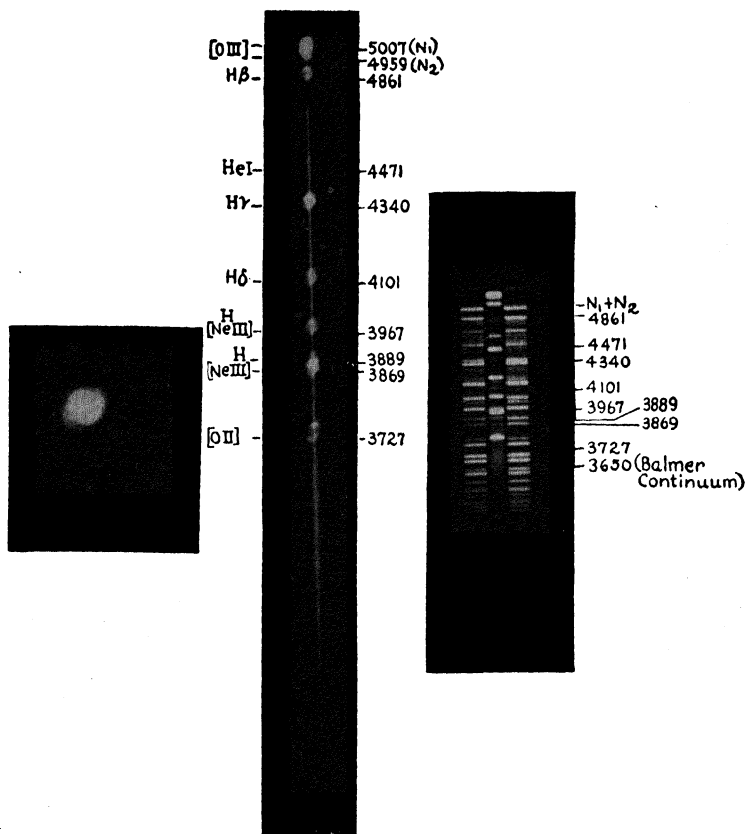

Fig. 91.—The planetary nebula NGC 6543.

We compare here a direct photograph made at the Harvard Observatory with slitless spectra (or prismatic photographs) and slit spectra obtained at the Lick Observatory. Note the strong lines of hydrogen and the *forbidden* lines of neon and oxygen. The continuous emission spectrum emitted beyond the limit of the Balmer series is also visible.

purities. Now seal the glass and allow it to expand, until the glass is as tall as Mount Everest and about two miles across. The vastly expanded contents of the glass would then be fairly comparable in density and composition to

the gas of a planetary nebula. It is only because the nebulae are so extremely large in their over-all dimensions that their light is perceptible to the astronomer.

OBSERVING THE PLANETARIES

Three methods of observing the planetary nebulae are illustrated in Figure 91. The first photograph is direct, that is, obtained in the ordinary way at the telescope, with light

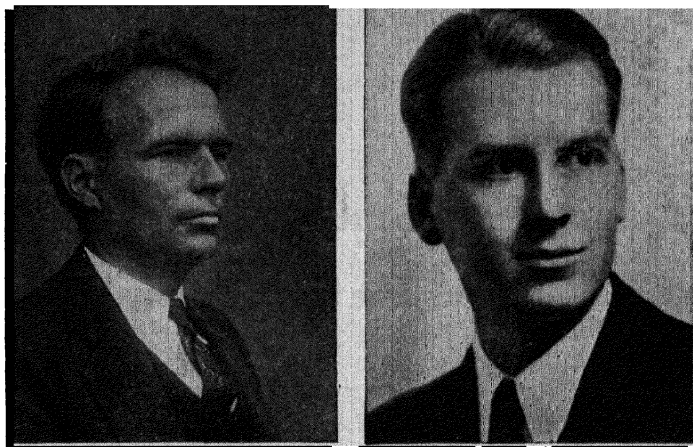

Fig. 92.—I. S. Bowen of the California Institute of Technology.

Fig. 93.—Arthur B. Wyse of the Lick Observatory. (Died in service of his country, June, 1942)

of all colors brought to a focus at the same place. With a prism placed in front of the telescope lens, we obtain a so-called prismatic photograph. The prism sorts out the light of the various colors, and the telescope lens forms a number of different images, each of which is a picture of the nebula in the radiation of some particular element's particular wave-length. The so-called slitless spectrograph utilizes the

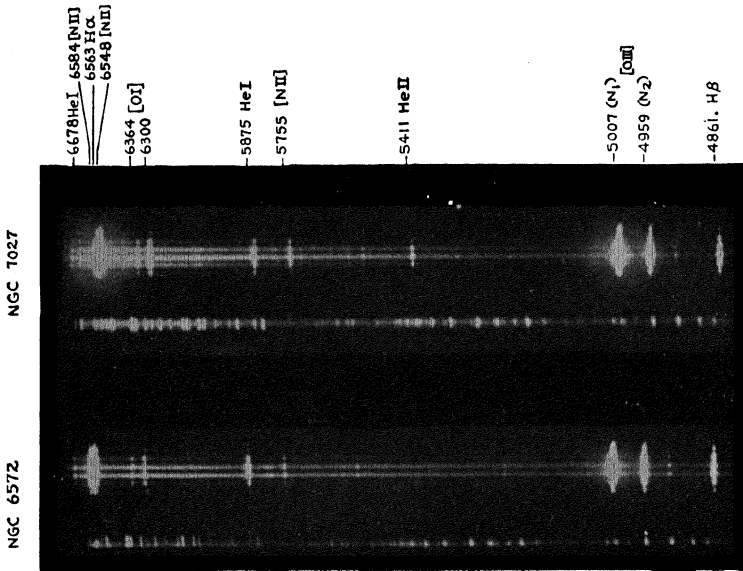

Fig. 94.—Slit spectra of NGC 6572 and NGC 7027.

I. S. Bowen and A. B. Wyse obtained these spectra at the Lick Observatory with the aid of the "image slicer" invented by the former. The radiation of ionized helium is present in NGC 7027 (lower) and missing from NGC 6572 (upper). Notice the strong forbidden nitrogen lines flanking $H\alpha$. (See legend, Figure 95.)

same principle. One of the obvious disadvantages of the prismatic photograph is the overlapping of images of nearly the same color (e.g. the 4959 and 5007 radiations of $OIII^*$). The slit spectrograph avoids this difficulty, but suffers the handicap of recording only a narrow section of the nebula on any one photograph. The advantages of both types of spectrographs have been combined by I. S. Bowen, of California Institute of Technology, through the use of an

* The stage of ionization of a particular atom is often designated by the addition of a Roman numeral. Thus, OI refers to neutral oxygen, OII to singly-ionized oxygen, etc.

ingenious device known as the "image-slicer." Before reaching the slit of the spectrograph, the nebular light falls on a system of tiny mirrors, which are arranged to slice the original image into a series of strips, and to align them end to end along the slit. Spectra of the planetaries NGC 6572 and NGC 7027, secured in this fashion by Bowen and Wyse, are shown in Figure 94. In Figure 95 we show the slitless spectra of several typical planetaries. Notice that the image of ionized helium is much smaller than that of doubly-ionized oxygen, which in turn is not as large as the faint, diffuse image of singly-ionized oxygen. This does not indicate that the element helium is absent from the outer parts of the nebula, but merely that the ionizing radiation from the central star is largely used up in the inner portions of the gas.

THE MYSTERY OF NEBULIUM

Although planetary nebulae display the well-known Balmer series of hydrogen, and certain of the familiar lines of helium, the strongest lines in the spectrum, those of oxygen II and III, have never been observed in the laboratory. Astronomers for many years were like Scott's Saracen. Believing themselves well acquainted with the spectra of all the common elements, they ascribed the unexplained nebular lines to a mysterious "nebulium," unknown on the earth. But the advance of chemistry and physics left no room for such a hypothetical element; we know now that these radiations are emitted by familiar elements like oxygen and nitrogen, shining under physical conditions not readily attainable on the earth. We shall now see how their origins were tracked down.

As we found in Chapter 3, spectral lines arise when an electron in the atom jumps from one energy level to another.

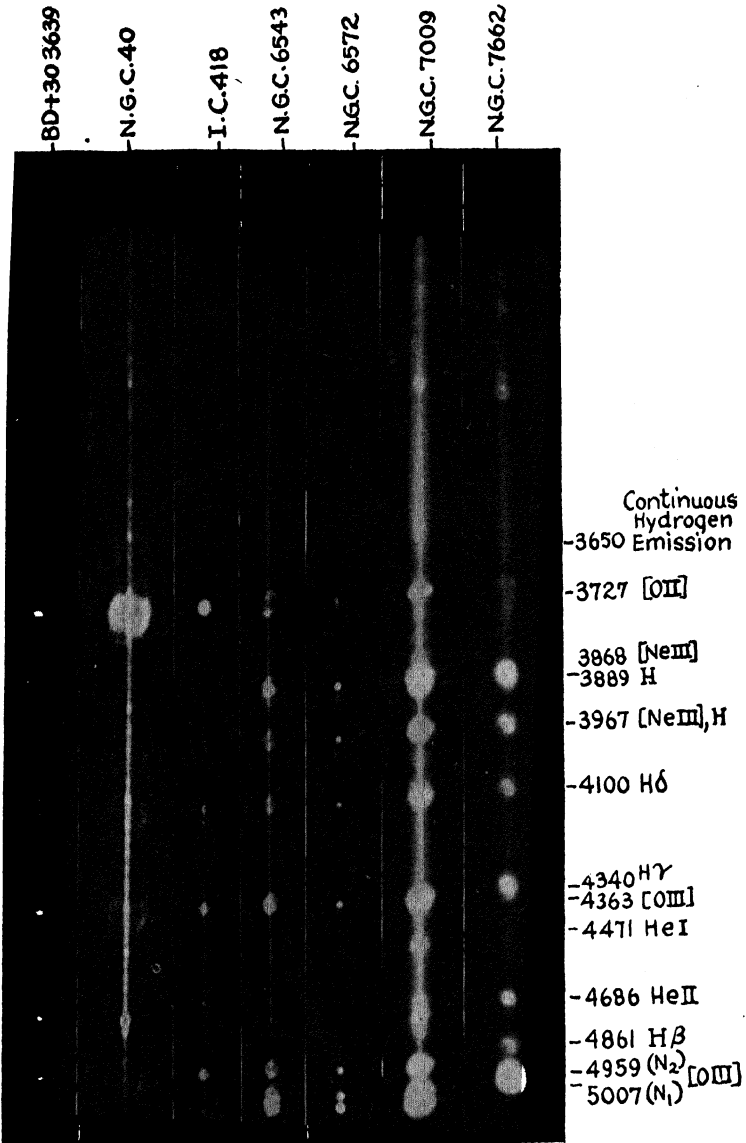

(For legend see facing page).

The transitions that are most probable, i.e., easy for the atom to accomplish, normally give rise to strong lines; those that are highly improbable, i.e., difficult, result in weak lines. The rules governing transitions are relatively simple, and are so restrictive that the number of spectral lines is far less than the number of possible combinations of pairs of energy levels. When beginning to analyze a spectrum, the physicist knows only the wave-lengths and frequencies of the spectral lines, and knows that these frequencies result from differences between atomic energy levels. The process of deducing the energy levels from the observed frequencies, which is somewhat like solving a jigsaw puzzle, is illustrated in Figure 96. The observed lines are (1), (2), and (3), and (1'), (2') and (3'). From the fact that the differences in frequency between the lines (1) and (1'), (2) and (2') and (3) and (3') are constant, we infer the existence of the pair of energy levels *A* and *B* with the same frequency difference. From other pairs of lines, we find the levels *C*, *D* and

Fig. 95.—Slitless spectra of some typical planetaries.

Explanation of Notation: [] means a "forbidden line," one not observed in the laboratory but predicted by theory. The Roman numeral stands for the stage of ionization. Thus HeII means ionized helium, OI neutral oxygen, OIII doubly-ionized oxygen, and [OII] refers to forbidden lines of singly-ionized oxygen.

The objects are arranged roughly in order of the increasing temperature of the central star. B.D. +30° 3639 consists of a Wolf-Rayet star with a nebulous envelope around it (see Chapter XI). Note the strong hydrogen lines and prominent forbidden lines λ 3727, of ionized oxygen. Only the hydrogen lines and λ 3727 appear in NGC 40. In I.C. 418 we see for the first time the green nebular lines of doubly-ionized oxygen, λ 5007 (N_1) and λ 4959 (N_2) of [OIII], but 3727 [OII] is yet strong. In NGC 6543 and NGC 6572 the forbidden neon lines 3967 and 3868 have appeared, N_1 and N_2 are strong, and λ 3727 is weakening. In NGC 7009 and NGC 7662 notice the strong ionized helium line λ 4686, and the ultraviolet lines of OIII. (Photographed at the Lick Observatory with the Crossley Reflector, and quartz spectrograph designed by W. H. Wright.)

E , always bearing in mind that the final pattern of levels must be consistent with the frequencies of all the observed lines. In spite of the fact that the line AB is not observed, because the rules of the game demand that this transition

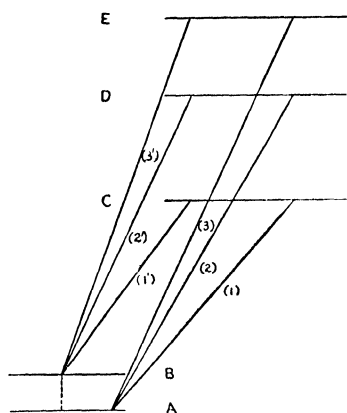

Fig. 96.—Diagram to illustrate the identification of energy levels.

We observe the lines (1), (2), and (3) corresponding to jumps from levels C , D and E to level A and also lines (1'), (2'), and (3') corresponding to jumps from C , D , and E to B . We infer the existence of energy levels C , D , E , and also B although we do not observe the line AB .

between B and A_1 correspond exactly with the frequencies of the pair of intense, green nebular lines at wave-lengths 4959 and 5007A. Also, the difference between C and B agreed with the wave-length of another nebular line at 4363A.

Bowen's discovery revealed the remarkable nature of the physical conditions in planetary nebulae, as the fol-

be highly improbable, we can still discover the levels A and B . Once an atom gets into level B , perhaps by collision with an electron, it must adopt a circuitous route to return to level A . It may, for example, absorb energy of the right wave-length to take it up to C , D , or E , after which it can come back to A by radiating the lines (1), (2) or (3).

By similar reasoning, physicists were able to deduce that the lowest energy levels of $OIII$ formed the pattern shown in Figure 97, even though transitions between these levels had never been observed in the laboratory. In pondering the origin of nebularium, I. S. Bowen noticed, in 1927, that the energy differences between B and A_2 , and

lowing arguments show. According to modern theory, an $OIII$ atom may jump from level B to level A , or from C to B , but its chances of doing so are exceedingly small—about a hundred million times less than the chance that a hydrogen atom will emit a line of the Balmer series. Another way of putting it is that, although an atom will linger but a hundred-millionth of a second in an ordinary level, it will remain in levels like B or C , so-called *metastable* levels, for seconds or minutes before returning to the ground level. For this reason, transitions of the type CB or BA_2 have been called “forbidden” although actually they are only highly improbable. Forbidden lines are generally indicated by a bracket around the symbol of the ion. Thus the violet line of singly-ionized oxygen is denoted by 3727 [OII].

Why, then, do the forbidden lines dominate the spectra of planetary nebulae? The answer is that the normal, or so-called permitted lines are very hard to produce under the conditions existing in the planetaries, while the forbidden lines are not.

In the discharge tube, atoms are excited and de-excited by collisions with fast-moving electrons. * An oxygen atom

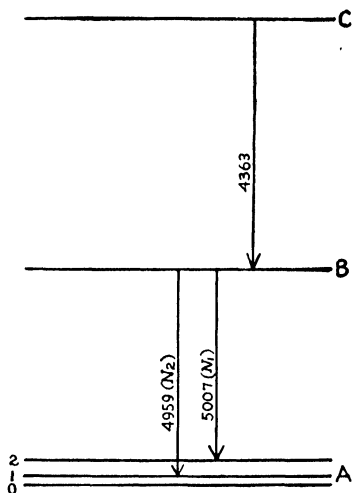

Fig. 97.—The lowest energy levels of $OIII$.

Transitions between these levels give rise to the 5007 and 4959 (green nebular) lines and the 4363 line.

* When an excited atom collides with another particle, its energy may be utilized in increasing the speed of the struck particle. Such an

which happens to land in level *B* or *C* will usually bump into the wall of the tube, another atom, or an electron and will disgorge its energy in the collision, all within a millionth of a second. The chance that it will emit a forbidden line in this time is very minute indeed. On the other hand, the stream of fast-moving electrons of the electric current excites the atoms to high normal levels from which they

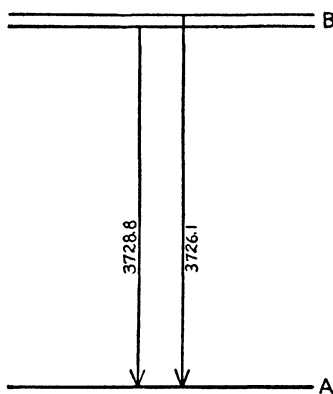

Fig. 98.—Diagram illustrating the origin of the 3727 lines of [OII].

return to lower levels with the emission of ordinary lines. These permitted lines are millions of times stronger than the forbidden lines.

In the planetary nebula, the electrons are not moving fast enough to excite atoms to the normal levels (whose excitation potentials are often as high as ten or twenty volts). On the other hand, the free electrons are moving sufficiently fast to excite atoms from the ground level to one or the other of

the metastable levels which are close to the ground level. Once an oxygen atom is in one of these metastable levels, it has little chance of colliding, within a minute or two, with another particle, disgoring its energy and returning to the ground level. So most of the atoms return to the ground level with the emission of a forbidden line. Once a quantum of forbidden radiation is created, it is sure to escape from the nebula, as the probability that it will be reabsorbed is negligible. Although the forbidden radiation per atom is

impact is known as a collision of the second kind. In a collision of the first kind, the energy of the impinging particle's motion may be used to excite the atom to a higher energy level.

actually somewhat weaker in the nebula than in the discharge tube, the planetary nebula is so vast (of radius about 10^{17} cms.), that the forbidden lines there may attain a considerable intensity. Normal lines are weakened enormously and forbidden lines relatively little from the vacuum tube to the gaseous nebula.

The forbidden lines of other atoms—nitrogen, neon, sulphur—are also observed in the planetaries. The *OII* atom is of particular interest, because it can remain in a metastable level for hours, before radiating a close pair of lines at 3727A. The lines are therefore found to be most conspicuous in nebulae with low densities.

FLUORESCENCE IN GASEOUS NEBULAE

Fluorescent rocks are among the most fascinating of all mineral displays in museums. We enter a darkened room and see a case filled with specimens, most of which shine dully by reflected white light, but, on pressing a button, we wreak an almost miraculous transformation. The white light vanishes, and suddenly the rocks glow in a sparkling array of colors. What has happened? When we extinguished the white light, we also turned on a source of ultraviolet radiation. Although invisible to the eye, the ultraviolet light is absorbed by the rocks and reradiated in visible colors; each ultraviolet quantum is split up into two or more quanta of longer wave-length.

A similar process is at work in the planetary nebulae. In spite of the fact that the nebulosity must derive all of its energy from the central star, the total amount of visible light radiated by the nebula is about forty or fifty times greater than that emitted by the star itself. The explanation may be traced to the fact that the central star is so hot that most of its energy is given out in the form of invisible ultraviolet light, as illustrated in Figure 99. But after being

absorbed by the nebular atoms, the invisible light energy is re-emitted in visible form. Hydrogen, by far the most

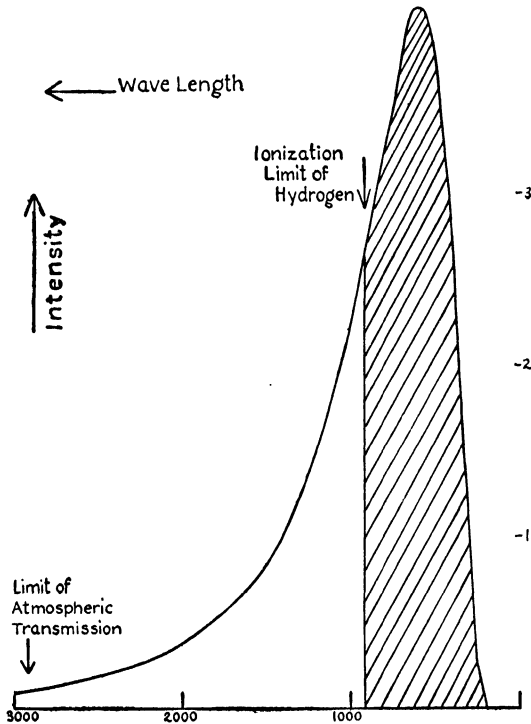

Fig. 99.—Distribution of radiant energy in the spectrum of a star whose temperature is $50,000^{\circ}$.

The energy distribution is plotted only for the region beyond λ 3000. Note that the energy maximum is in the far ultraviolet. The cross-hatched area corresponds to the fraction of the total energy available for the ionization of hydrogen. Virtually all of the energy we observe in planetary nebulae comes ultimately from radiation in the far ultraviolet.

abundant constituent of the stars and nebulae, is the atom that is mainly responsible for the transformation of the unseen into the seen.

Let us see what happens when the ultraviolet radiation of the star impinges upon a shell of hydrogen gas. A quantum of wave-length less than 912A possesses sufficient energy to tear the electron away from a hydrogen atom. Such an electron, detached from an atom, may wander about in space until recaptured by a proton. Although the electron was torn away from the smallest orbit, it may, when it is recaptured by some other proton, land in any of the orbits, the higher ones as well as the lower ones (see Figure 100). If the free electron is captured in the lowest orbit, a quantum similar to the original quantum from the star will be reborn, and this quantum, escaping from the atom, may ionize yet another hydrogen atom.

Now an electron captured in one of the higher orbits may jump to any one of the lower levels, radiating as it jumps, or it may absorb another quantum of starlight and leap to a higher orbit. But conditions in the planetaries do not favor this latter process. As a glance at Figure 99 will show, the central star is relatively poor in the low-frequency radiation that is required to excite a hydrogen atom from one of the higher levels to another. Furthermore, the nebula is so enormous compared with the star that the starlight is spread over a vast area and its intensity at any point is very low. When the radiation is so "diluted," an excited hydrogen atom has little chance of absorbing another quantum, because it remains excited for only a hundred-millionth of a second. Also, as we have already seen, the density is so very low that the prospect of a collision with another particle is remote. Hence the atom has no alternative but to return to the ground level, either in one jump or to cascade down by stages.

Each electronic jump is of course accompanied by the radiation of a light quantum. Thus if the electron is captured in the second level, the atom will radiate energy in

the near ultraviolet, beyond the limit of the Balmer series. The exact wave-length is determined by the energy of motion of the free electron.* From the second level the electron drops to the lowest level, and the atom emits the

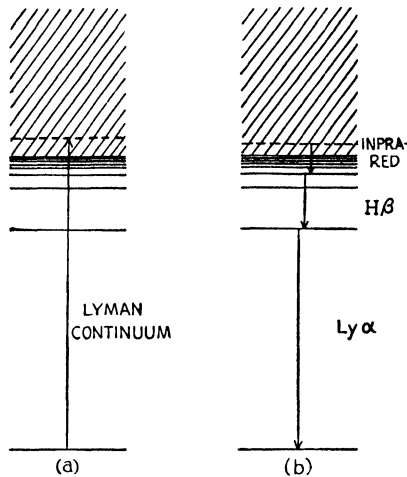

Fig. 100.-- Diagram illustrating the origin of hydrogen emission lines in the spectra of the planetary nebulae.

(a) An atom in the ground level of hydrogen absorbs an ultraviolet quantum of energy and the electron is ejected from the atom. (b) The electron is recaptured in the 4th level with the emission of an unseen infrared quantum. Then it cascades to the 2nd level with the emission of $H\beta$, which is observed, and finally to the ground level with the emission of unobservable Lyman α .

first line of the Lyman series. Many of the electrons caught in high levels, however, will fall to the second level and thereby produce the bright Balmer lines so prominent in

* We saw in an earlier chapter that captures of free electrons in the second hydrogen level produce a continuous spectrum to the violet of the Balmer series limit. This continuum, discovered by W. H. Wright, is conspicuous in the spectra of NGC 7009 and 7662 (Figure 95), gradually decreasing in intensity toward the ultraviolet.

the spectra of planetaries. Eventually, all of the stellar radiations of wave-length shorter than 912A are converted into light of lower frequencies, a large percentage of which falls in the visible region of the spectrum.

The observed radiations of neutral and ionized helium originate in the same way as for hydrogen, by ionization and recapture, but the radiations necessary to remove one and two electrons from helium lie very far in the ultra-violet, beyond 506A and 228A, respectively. The central stars of planetaries that show lines of ionized helium are therefore among the hottest stars known, with temperatures in excess of 100,000°.* The spectra of the central stars of planetaries frequently show broad bright lines of the Wolf-Rayet type (Chapter 11) superposed on the continuous spectrum. They show certain strong resemblances to old novae in that they are very hot, blue stars of rather small dimensions, and presumably high densities. Thus the nucleus of NGC 7662 probably has a diameter about a fourth that of the sun but radiates perhaps a thousand times as much energy.

* If all the stellar radiation emitted beyond the limit of the Lyman series is absorbed by hydrogen atoms in the nebula, Zanstra and Menzel independently showed that it would be possible to estimate the temperature of the central star. If the nebula is so thick that there are a great number of absorptions and re-emissions, each quantum of ultra-violet energy eventually becomes broken down into a quantum of Lyman radiation and one of Balmer radiation. The latter escapes at once from the nebula, the former is repeatedly absorbed and re-emitted until it escapes. The number of quanta emitted by the whole nebula in the Balmer series may be observed (the energy in each of the slitless images of Fig. 95 divided by $h\nu$) and compared with that radiated in the ordinary photographic region of the star. Since the number of Balmer quanta equals the number of quanta beyond the Lyman limit radiated by the star, we can find what proportion of energy is radiated by the star in the far ultraviolet, and hence determine its temperature from the radiation laws (Chapter 4).

THE THERMOSTAT ACTION OF NEBULAR LINES

An interesting sidelight in connection with the forbidden lines of oxygen, nitrogen and neon is that their production acts as a thermostat to regulate the temperature of the nebular gas. Let us suppose that the nebula is composed entirely of hydrogen. The temperature of the gas is measured by the speeds of its atoms and electrons, which in turn depend on the temperature of the central star. If the star is hot and therefore rich in high-frequency radiation, electrons will be torn away from their hydrogen atoms at high speeds. These electrons dash about, and, if they collide with neutral hydrogen atoms, they bounce away without loss of energy, unless they are moving very fast indeed, about 200 kilometers/seconds. At this and higher speeds they possess energy enough to excite hydrogen atoms from the ground level up to the first excited level. In a pure hydrogen nebula, the nebular temperature would depend strongly on that of the star until the temperature rose to sixty or seventy thousand degrees, when excitation of the second and higher orbits of hydrogen by collisions with electrons would become important. At this point so much energy would be lost by the electrons in collisions that a further temperature rise would be inhibited.

Suppose now that we introduce small amounts of oxygen, nitrogen and neon into the hydrogen nebula. These atoms possess metastable levels two or three volts above the ground level, and the energies of the free electrons become dissipated in exciting these "foreign" atoms to metastable levels. The energy radiated in forbidden lines, which arises at the expense of the energies of motion of the free electrons, is forever lost to the nebula, because the forbidden radiations cannot be re-absorbed. Thus the nebular gases are effectively cooled and although the temperatures

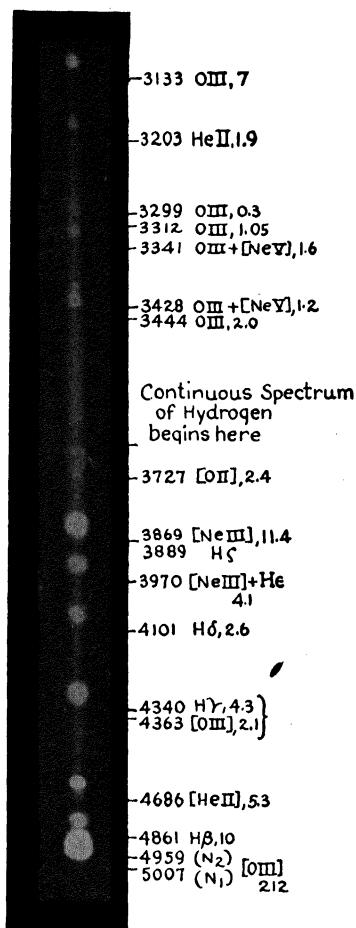

Fig. 101.—The spectrum of NGC 7662.

This reproduction of a 3-hour exposure made with the Crossley slitless spectrograph is intended to show the ultraviolet emissions of doubly-ionized oxygen. Note that these images are comparable in size with that of λ 4686 of ionized helium while the images of hydrogen and [O III], and especially λ 3727 of [O II] are conspicuously larger. Intensities of the nebular lines corrected for the transmission of sky and instrument and plate sensitivity are given.

length of the radiation required to excite this level is 304\AA , which coincides almost exactly with the strongest line of ionized helium. The 304\AA line corresponds in ionized helium with the first line of the Lyman series in hydrogen. When a twice-ionized helium atom captures an electron, becoming once-ionized, the final stage in the cascading process is often the transition from level 2 to level 1. Hence this HeII line, although invisible, probably attains great strength in the planetaries. As shown in Figure 102, the OIII atoms in the ground level absorb the plentiful 304\AA radiation of HeII , are excited to the high level, and then return by successive stages with the emission of the observed lines. The missing lines are not observed because they originate from other levels that do not have fortuitous sources of energy. Even more remarkable is the circumstance that, as the OIII ion finally returns to the lowest energy level, it emits a radiation at 374\AA , which is of just the right wave-length to generate a similar cycle in NIII , producing the observed lines near 4640\AA and 4100\AA . Bowen's explanation is supported by the fact that the permitted lines of OIII appear only in those portions of the nebula where the

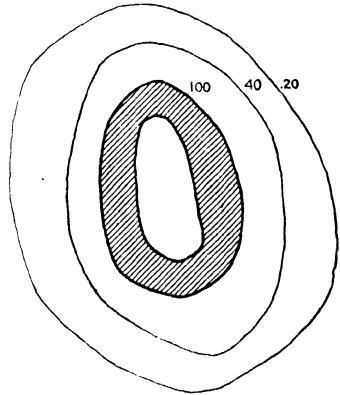

Fig. 103.—Distribution of brightness in the image of the $\lambda 4686$ ionized helium line in NGC 7662.

This diagram shows how the brightness falls off in one of the prismatic images of a spectral line. Such studies were first made by Berman. If the brightness of the central ring is taken as 1.00 the outer larger rings are respectively 0.40 and 0.20. The length of the arrow denotes 10,000 astronomical units.

observable lines of ionized helium are strong, and therefore where the 304A line also is presumably intense.

THE ORIGIN OF PLANETARIES

A planetary nebula may be regarded as a star with an enormously distended, transparent atmosphere. Is it possible that these atmospheres may be the debris of old novae? Careful observations by J. H. Moore and W. W. Campbell, at Lick Observatory, have shown that the spectral lines of planetary nebulae are curved and doubled, which, as in the Crab nebula, indicates that the entire nebulous envelope is expanding. We have seen that Nova Aquilae and Nova Persei are now surrounded by expanding shells, and also that many old novae are intensely hot.

The difficulty with this explanation is that whereas the novae eject their gases at speeds of hundreds of miles per second, the expansion velocity of a typical planetary is only 15 miles per second. Either the speed of nova expansion slows down with the passage of years,* or else the planetaries may have originated from slowly-developing novae such as *RT Serpentis*.† Whipple has made an interesting estimate of the ages of planetary nebulae, by assuming that they have always been expanding at their present rates. He finds that they are relatively short-lived members of the universe, with ages of the order of 30,000 years. Within a few score thousand years—a mere moment in the life of a star—the nebulous fragments will have expanded into the “vacuum” of interstellar space. Possibly new planetaries will appear in the future to replace those that are now fading from the scene.

* There is some indication that the shell around Nova Persei is now expanding more slowly than at the time of outburst in 1901.

† See Campbell and Jacchia, *The Story of Variable Stars*, p. 127.

BETWEEN THE STARS

*I*N AN ELEMENTARY EXAMINATION IN ASTRONOMY A student was asked to discuss the composition of comets. Caught unprepared, he was forced to rely on his wit and wrote, "Comets contain a great deal of vacuum." Judged by terrestrial standards the answer was not entirely incorrect, for the tails of comets, the planetary nebulae, and even the atmospheres of some supergiant stars are in much more rarefied conditions than the most perfect vacuum that can be obtained on the earth. The word vacuum should evidently be used only in a relative sense, for even the great reaches of interstellar space are not wholly devoid of matter. Nature does indeed "abhor a vacuum".



A glance at any ordinary photograph of the Milky Way shows that space is not empty.* The bright patches of nebulosity, the great rift in Cygnus, and the inkiness of the Coal Sack all testify to the reality of the great clouds of occulting matter that fill up "empty" space. The reader may judge for himself by inspecting the famous Horsehead

* See the maps of the Milky Way in Bok and Bok, *The Milky Way*.



Fig. 104.—The Horsehead Nebula in Orion.

(From a photograph taken by John C. Duncan with the 100-inch reflector at Mount Wilson.)

nebula in Orion, shown in Figure 104. He will see that the dark areas are not holes through which we look into empty space but rather clouds of some material, probably a mixture of fine dust and gas, that obscures the light of the background stars.

Early theories of the formation of the interstellar medium suggested that interstellar particles represent wandering debris blown out from the stars by the violent pressure of radiation. Such a process appears to be at work in the novae, and perhaps in a majority of stars, but observations indicate that most of the gaseous material apparently ejected from the solar surface falls back (see Figure 105). Recent analyses of the abundance of interstellar gas have shown, however, that the total mass of material in space is considerably greater than had originally been suspected and may actually equal the combined masses of all the stars in the galactic system. That such a quantity of matter could have been ejected from the stars seems hardly as plausible as the hypothesis that the interstellar cloud has been in existence from the "beginning."

Before discussing the nature and quantity of the material in space, we find it interesting to note that an estimate of the total mass of the interstellar cloud may be obtained from a study of the motions of stars in the solar neighborhood. According to the theory of the rotation of the Milky Way, the stars revolve in its plane about the galactic center in the direction of Sagittarius. If all the mass of the galaxy were confined to a small region near the center, the motions of stars distant from the center would be confined purely to orbits in the galactic plane, in analogy with the revolution of planets about the sun. The sun, however, is twenty-five or thirty thousand light years from the center of the galaxy, and the motions of the stars in its neighborhood are governed not only by the distant and massive

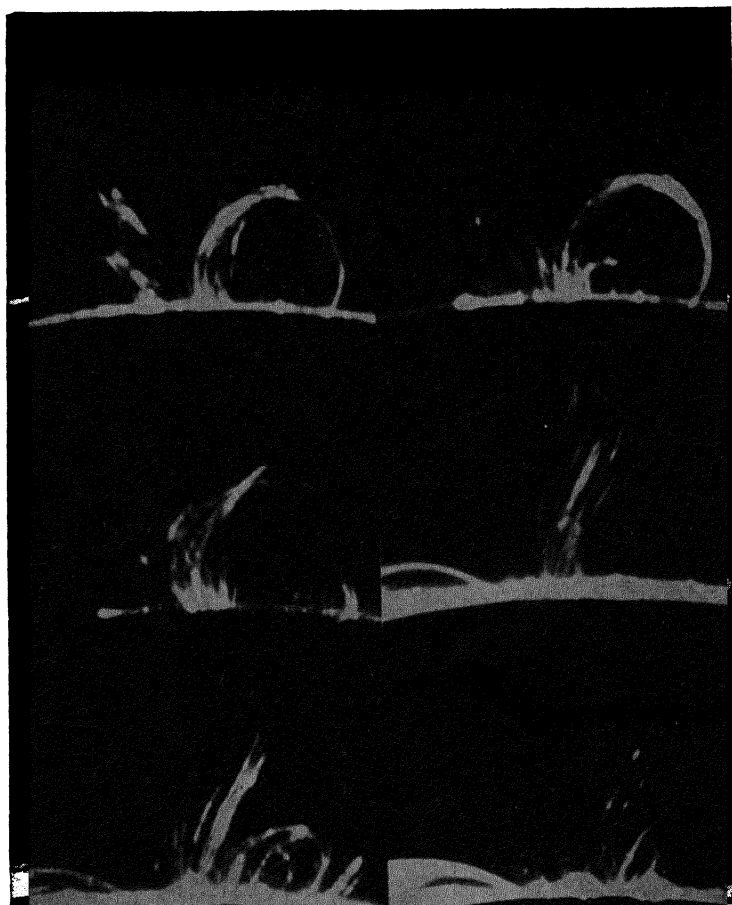

Fig. 105.—*Prominences on the sun.*

These two "sunspot-type" prominences of Sept. 7 and 21, 1939 were photographed at the McMath-Hulbert Observatory in the light of the red hydrogen line. Practically all of the streamers and knots are moving downwards. About 90 per cent of the material in prominences observed at Lake Angelus is in descent only.

Sept. 21, 14 ^h 38 ^m	Sept. 21, 15 ^h 5 ^m
Sept. 21, 16 59	Sept. 7, 16 6
Sept. 7, 18 41	Sept. 7, 20 37

galactic nucleus, but also by the total amount of matter in our immediate vicinity. One effect of this surrounding material is to set the stars oscillating to and fro in a direction perpendicular to the Milky Way plane. Oort's studies of the speed of this oscillatory motion indicate that the total density of matter in the solar vicinity is about 6×10^{-24} grams per cubic centimeter. The known stars contribute about half of this figure, which leaves a density of 3×10^{-24} grams per cubic centimeter to be accounted for by dust and gas.

A significant clue to the nature of the particles responsible for "blacking out" the stars comes from a study of the colors of stars that are only partially obscured. In an earlier chapter we have seen how the color of a star is related to its temperature. In general, the cool stars are red and yellow in color, whereas the hot stars are blue. The types of lines that appear in the stellar spectrum are a good criterion for the temperature, and therefore for the color of the star. In many regions of the Milky Way, one finds stars that show spectral lines characteristic of high temperatures; yet these stars appear red. We may, therefore, surmise that the light reaching us from these objects has been not only dimmed, but reddened as well. The phenomenon is not unlike the appearance of the sun as it sets, reddened, in a dusty or smoky atmosphere.

The fact that some interstellar particles possess the ability to redden star light tells us that they must be smaller than about one thousandth of an inch in diameter, for large obstacles, like meteoric fragments, will simply block starlight without affecting its color. At the other end of the size scale, we find that the free electrons may also be ruled out as a factor for obscuring stars because, they, too, are incapable of changing the color of light. On the other hand, particles of the size of atoms or molecules, about one hundred-

millionth of an inch in diameter, are very powerful reddeners. We have a daily example of this phenomenon in the blueness of the sky and in the redness of the rising and setting sun. The sky is blue only because the earth has an atmosphere. As the rays of sunlight pass through the atmosphere, they are deflected sidewise from their original paths by the molecules of air. The deflection of light by small particles is known as *scattering*, a term that we shall have occasion to use frequently. It so happens that blue rays are more easily deflected by molecules than red rays. Consequently, most of the sunlight that is scattered is blue and it is this diffused blue light from the sun that provides the beauty of the blue sky. Manifestly, the scattering process removes blue rays from the original solar beam, and the sun appears redder than it would be in the absence of the atmosphere. Also the reddening of the sun is most pronounced near the horizon, when its rays traverse a long column of the blue-eliminating atmosphere.

Yet, in spite of the fact that, as we shall see presently, interstellar space contains many atoms and molecules, these cannot be blamed for the dimming of distant stars. Atoms and molecules are simply too efficient as reddeners because their scattering power varies inversely as the fourth power of the wave-length of the light that falls upon them, that is, they scatter ultraviolet light ($\lambda = 3000\text{A}$) sixteen times as efficiently as red light ($\lambda = 6000\text{A}$). Actual observations of the colors of stars show that the interstellar particles cut down the intensity of ultraviolet light only twice as much as the red.

Recent studies, especially by Schalén of Upsala, Sweden, and Greenstein and Henyey of the Yerkes Observatory, indicate that particles of intermediate size (from one thousandth to one one-hundred-thousandth of an inch in diameter) will scatter light in such a way as to reproduce

the observed degree of coloring of distant stars. Interstellar space appears to be strewn with fine dust particles larger than molecules and atoms, yet so small that most of them could be seen only with a powerful microscope. Thus, dust so fine as to be invisible to the eye is responsible for the blacking out of distant stars.

What is the composition of the dust particles? Are they metallic, (e.g. iron or nickel) or are they non-metallic (e.g. silica-dust, ice crystals)? Obviously, we cannot get a sample of the interstellar material to analyze in the chemical laboratory. Fortunately, metallic and non-metallic particles behave differently in the ways they reflect, absorb, or scatter light. When light falls upon a non-metallic substance such as sand, most of it is *scattered*, that is reflected by myriads of tiny mirror-like surfaces. On the other hand, much of the radiation falling upon a metallic surface, e.g. polished copper, may be actually *absorbed*, i.e. converted into heat.

The reason for this behavior is to be found in the nature of light waves and certain differences between metallic and non-metallic substances. Metals are good conductors of electricity, non-metallic substances like glass, silica, or ice are non-conductors, i.e. *insulators*. Metals contain large numbers of electrons that are not attached to atoms, but are free to wander to and fro. An electric current in a wire consists of a flow of these *free* electrons. Rapidly fluctuating electric and magnetic fields are associated with light waves; therefore when a light wave strikes a metal, the electric field produces a rapid to and fro motion of the electrons. As the electrons rush about, they bump into atoms and lose energy, which appears as heat. The phenomenon is exactly the same as the heating of a wire by an electric current. The energy necessary to propel the electron comes from the light beam, which is therefore diminished in intensity. On the other hand, the electrons in an insulat-

ing substance like sand are tightly bound and not free to move. Consequently, when a light beam falls upon a non-metallic or insulating substance, its energy is not dissipated by setting electrons in motion and the beam is deflected almost without energy loss. Thus the reflectivity, or *albedo*, of non-metallic insulating materials is high whereas that of metals is low.

If starlight were absorbed rather than scattered, the spaces between the stars would be rather dark, because the interstellar material then would reflect very little light.* With a photoelectric cell, Elvey and Roach measured the intensity of the radiation in the Milky Way. After they had subtracted the amount of light contributed by the stars, they found that a considerable amount of radiation remained, presumably starlight scattered by small particles in the Milky Way. This diffused starlight amounted in intensity to about 57 tenth-magnitude stars per square degree.

Recently, Greenstein and Henyey have studied the problem in some detail. They conclude that the scattering efficiency, or albedo, of the interstellar particles lies somewhere between 0.3 and 0.8. If cosmic dust consisted of small metallic particles, the reflectivity would be considerably less.

It appears probable, then, that the dirty work of obscuring starlight is done, not by metallic particles, although some

* The great dust clouds like the Horsehead nebula would not be completely black but would shine faintly by reflected light. Struve and Elvey in 1937 compared the surface brightnesses of dark nebulae with the supposedly black spaces between stars in nearby unobscured regions. They found only slight differences between the two regions and concluded that either the reflectivity of the cloud particles is very low or considerable starlight is scattered in interstellar space. Elvey and Roach showed that the latter alternative is probably the correct one.

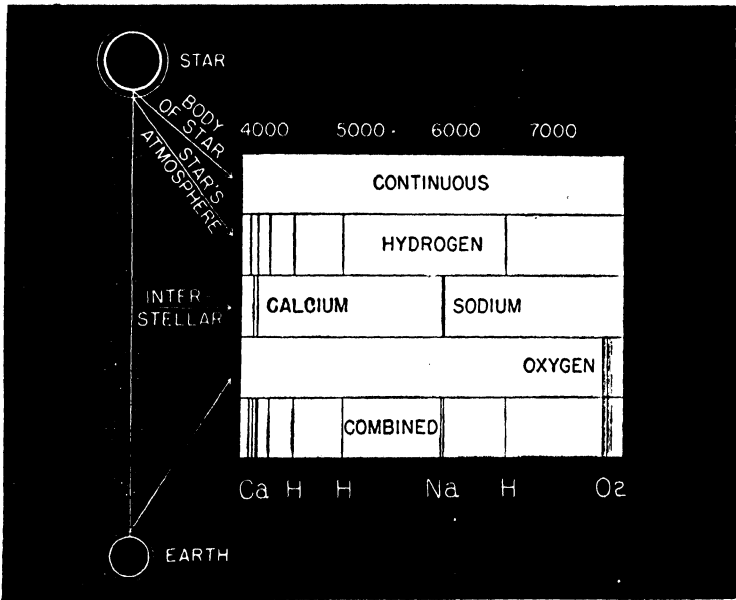

Fig. 106.—Schematic diagram showing origin of the interstellar lines.

(After P. W. Merrill.)

may be present, but perhaps by dusty grains of glass and silica dust, or even by frozen gases, ice, or some other common substance converted to an unknown form by the low temperature, close to the absolute zero, that prevails in interstellar space.

THE INTERSTELLAR GAS

A small quantity of interstellar dust goes a long way in obscuring starlight, so that dust clouds probably contribute but a fraction of the total mass of interstellar matter. By far the most abundant constituent is probably represented by the more or less uniform cloud of gas—atoms and molecules—in which the stars of the galactic system are im-

mersed. The great extent of the gas cloud has been revealed by the spectroscope. Interstellar gas absorbs starlight in certain particular wave-lengths in the same way that a stellar atmosphere absorbs light from a photosphere and thus imprints absorption lines of the familiar elements upon the continuous spectrum. (See Figure 106.) So tenuous is the interstellar cloud, however, that an exceedingly long column of gas is required to produce an absorption line of sufficient strength to be visible in a stellar spectrum. The observation of interstellar lines is, therefore, confined chiefly to the more distant stars.

The first element to be discovered in interstellar space was ionized calcium, found by Hartmann in 1904 in the spectrum of Delta Orionis, a close double star. When the orbital plane of a binary star is nearly in the line of sight, the revolving components will alternately approach and recede. The motion will be mirrored in the spectrum where, due to the Doppler effect, the absorption lines will appear to oscillate in position in the period of revolution (see Figure 107). Absorption lines produced by interstellar gas, which does not share the orbital motion, will, however, appear stationary. Since the *K* line of ionized calcium does not share the periodic motion of the other lines of Delta Orionis, it must be produced in a cloud of gas detached from the star.

Miss Heger, at the Lick Observatory in 1919, discovered stationary lines of neutral sodium, and the interstellar lines of both ionized calcium and neutral sodium have now been recognized in the spectra of a large number of stars. The low density of the gas in space makes the interstellar lines extremely sharp, a feature that often enables them to be distinguished from ordinary lines in the spectra of stars that are not members of binary systems. In recent years, Dunham and Adams at Mount Wilson have added the

atoms potassium, titanium, and neutral calcium to the constituents of interstellar space. Adams has recently detected interstellar iron.

The possibility that interstellar gas may also contain more complex types of matter, in the form of chemical

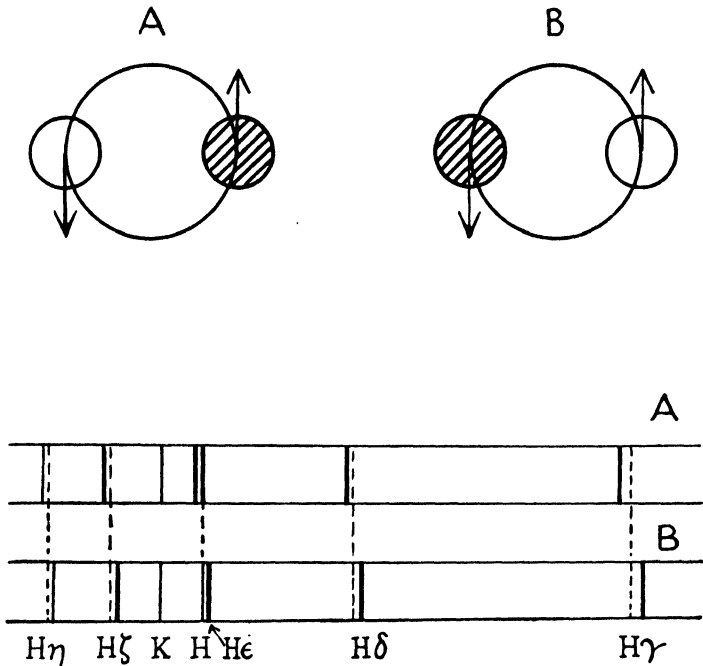

Fig. 107.—How interstellar lines were discovered.

In *A* the brighter star is approaching the observer, in *B* it is receding. Consequently, the absorption lines are shifted towards the violet in the upper figure and towards the red in the lower, but the stationary *H* and *K* lines, due to the interstellar cloud, remain unchanged in position.

compounds, has been suggested many times during the past few years. One of the unidentified lines observed by Dunham in 1937 was tentatively assigned by Swings and Rosenfeld to the hydrocarbon CH, whose lines make up

the great *G* band of the solar spectrum. But it was McKellar, of the Dominion Astrophysical Observatory, who conclusively established the presence of interstellar molecules. He showed that if the line assigned to CH really belonged to this molecule, there should be 3 other faint lines elsewhere in the spectrum. W. S. Adams looked for these lines and also for others of cyanogen, CN, in the spectrum of Zeta Ophiuchi. The predicted lines were all in their correct

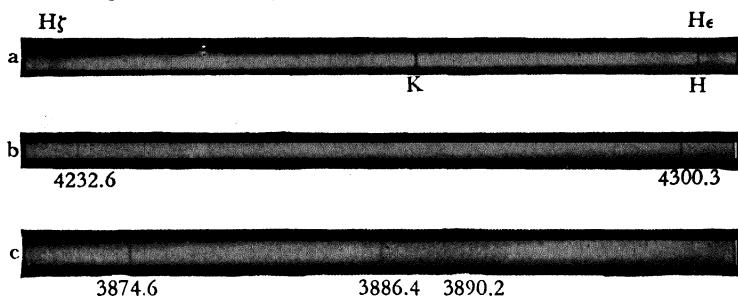

Fig. 108.—Stellar spectra showing absorption lines due to interstellar gases.

a. 55 Cygni. H and K lines due to interstellar ionized calcium, and diffuse lines due to stellar elements.

b. ζ Ophiuchi. Interstellar lines λ 4232, ionized CH, and 4300, neutral CH.

c. ζ Ophiuchi. Interstellar lines of CH, λ 3885 and λ 3890; also λ 3874.6 and a trace of λ 3874.0, both cyanogen (CN). (Reprinted by the courtesy of Dr. Robert G. Aitken, Chairman, Committee on Publications, Astronomical Society of the Pacific.)

positions with their calculated intensities. In a sense the discovery killed two birds with one stone for it also established the presence of the atoms carbon and nitrogen. It also supported previous indications that hydrogen must be very abundant in interstellar space.

The actual appearance of some of these interstellar lines in the spectra of the stars 55 Cygni and Zeta Ophiuchi is illustrated in Fig. 108. Note the extreme sharpness of the

interstellar lines as compared with ordinary absorption lines that come from the reversing layer of the star. The lines are best seen in the spectra of the hot *B* stars, where the stellar lines of molecules and metallic atoms are absent. It is evident that the intensities of the dark interstellar lines will depend upon the distances of the stars, for the light of a faraway star must pass through a longer column of gas than

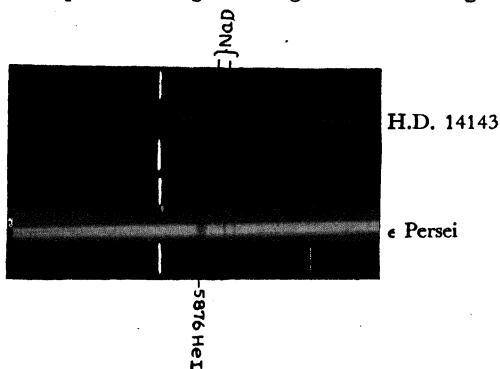

Fig. 109.—Interstellar sodium lines in a nearby and distant star.

In the nearby star ϵ Persei, the sodium lines are weak, but in the distant H.D. 14143, they are quite strong. (*Mount Wilson Observatory.*)

light from a nearby star. The effect is clearly illustrated in Figure 109, where the lines of interstellar sodium are shown in the spectra of two stars, one close at hand and the other very distant. The interstellar gas thus supplies us with a useful measuring rod for estimating the distances of the stars.

If we could employ a cosmic steam shovel to reach out into space and scoop up a gob of the interstellar stuff, we would probably find that the sample contained most of the common elements that are found on the earth and in the stars. That the thumb prints of most of these elements have not been found may be traced to the physical conditions in interstellar space. Even the planetary nebulae are

dense compared with the gaseous material of interstellar space; the gas is so exceedingly rarefied that only the most abundant elements and compounds can be detected.

Ionization of the atoms takes place at a very slow rate because the ionizing radiation comes from great distances and is consequently very feeble. Nevertheless, once in a while a high-frequency quantum will come along and tear an electron away from an atom. Once ionized, an atom stays that way for a long time, because at the very low density its encounters with other free electrons are very infrequent. Consequently, most of the atoms of calcium and sodium, for example, are ionized.

Radiation capable of exciting atoms to higher energy levels is very weak, and collisions capable of lifting electrons from their ground levels to excited levels are rare. Consequently, the atom spends most of its time in the very lowest state of energy. Most atoms in this placid state, particularly those of the permanent gases, are indifferent to visible light, and will absorb radiation only from the invisible, very short wave-length region of the spectrum, which is not transmitted by the earth's atmosphere. Hence the majority of interstellar atoms evade discovery, even though they may be very abundant.

A case in point is hydrogen, whose interstellar dark lines have never been observed. Most of the hydrogen atoms near hot stars must be ionized; but occasionally they recapture electrons in the second, third, fourth or higher orbits. As these electrons cascade to lower orbits they emit radiation. Now only atoms in the second energy level, i.e., atoms whose electrons are in the second orbit, are capable of absorbing the Balmer series. Even though an electron may land in the second orbit, it will remain there but a hundred-millionth of a second before dropping to the lowest orbit. In order for a line of the Balmer series

to be absorbed, a quantum of light of just the right frequency must come along during that time interval. The chance of that happening in interstellar space is extremely small.

It might be expected, however, that the downward cascading of captured electrons would produce a faint glow of light in the spaces between the stars. By means of a specially designed spectrograph, Struve and Elvey, at the McDonald Observatory in Texas, have been able to register this faint light, in the form of bright lines of hydrogen and ionized oxygen, in large regions of the Milky Way. They find, however, no emission lines in high galactic latitudes away from the Milky Way. The hydrogen emission regions are often sharply bounded and associated with groups of O-type stars. Struve estimates the diameters of the regions to range from 80 parsecs for a region in Orion to 250 parsecs for the Cygnus nebulosity. The 3727 line of [OII] is nearly always present in the regions of hydrogen emission; and the green nebular lines of [OIII] are also sometimes observed.*

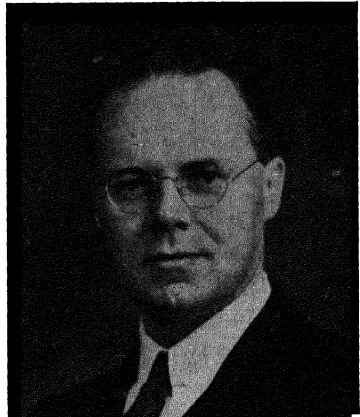

Fig. 110.—Otto Struve of the Yerkes and McDonald Observatories.

* The forbidden lines of neutral oxygen, [OI], are not observed, although we might expect them in the regions where hydrogen is not ionized. Presumably, the explanation for their non-appearance is that their upper metastable levels have small likelihood of being excited by collisions, that is to say, the *target areas* of neutral oxygen atoms for collisions are small.

Strömgren worked out the theory of the ionization of hydrogen in interstellar space. He predicted that for a radius of about 30 parsecs in the neighborhood of an *O*-type star, hydrogen would be completely ionized; then there would be an abrupt boundary and a few parsecs farther out all the hydrogen would be neutral. Within the hydrogen ionization region the emission lines would be produced as the electrons are recaptured and cascade to lower levels.*

Beals, of the Dominion Astrophysical Observatory, discovered several years ago that the interstellar *H* and *K* lines of ionized calcium are double in many stars. The doubling has generally been ascribed to the absorption of starlight by two interstellar clouds with different radial velocities, the difference in wave-length between the two line components being proportional to the difference in radial velocity between the two clouds. Very recently, the Mount Wilson observers, aided by new and powerful spectrographs attached to the 100-inch telescope, have greatly extended the list of stars with double interstellar lines, finding also that the *D* lines of neutral sodium often appear double. Some stars have even been found to show as many as three or four components for each line.

Strömgren's suggestion that the physical conditions in interstellar space should vary from one region to another has received some observational verification at Mount

* In the zone where the hydrogen is ionized the electron density amounts to 2 or 3 electrons/cm.³ Outside this zone, the electron density falls to 10^{-2} or 10^{-3} . Now the atoms of the metals may be easily ionized in either region since hydrogen has only a slight effect on the radiation available for their ionization. However, they may recover electrons in the region of ionized hydrogen much more easily than in the region of neutral hydrogen. Accordingly most of the neutral sodium and neutral and singly-ionized calcium probably exists in the former zone.

Wilson. R. N. Sanford found, in 1940, that the star H.D. 190429 shows double interstellar lines of ionized calcium, but only single lines of neutral sodium. This observation might imply that the sodium atoms are mostly neutral in one cloud and mostly ionized in the other. Additional confirmation of this point comes in a recent report from W. S. Adams that the gaseous clouds of space seem to be divided into two groups: one in which the atomic lines of metallic elements such as calcium, sodium, titanium and iron are most intense, and another in which the molecular lines of CN, CH, and ionized CH are relatively strong.

Both Struve at Yerkes and Dunham at Mount Wilson have undertaken a census of elements in interstellar space. We summarize their results in Table 10, which gives the

TABLE 10
COMPOSITION OF INTERSTELLAR MATERIAL

<i>Element</i>	<i>Struve</i>	<i>Dunham</i>
Hydrogen.....	2,000,000	10,000,000
Oxygen.....	1,000	
Sodium.....	1	100
Potassium.....	10
Calcium.....	0.1	4
Titanium.....	0.02
CH.....	1	
CN.....	1	

numbers of each of the various kinds of particles in a cubic meter. In interstellar space, as in stellar atmospheres and planetary nebulae, hydrogen far outstrips all other elements in abundance. It is interesting to note that both investigations suggest that sodium is ten or twenty times as abundant as calcium, whereas these elements are about equally abundant in the earth's crust and in the solar atmosphere.

To say that the interstellar material is spread very thinly is a gross understatement; a good approximation to the density of the stuff can be achieved by pulverising an ordinary marble and spreading it as evenly as possible throughout the volume of a sphere 1000 miles in diameter.

THE BRIGHT NEBULAE

There seems to be a prominent tendency for the mixture of interstellar dust and gas to collect in small clouds and condensations. Often these clouds will not only dim but completely obscure the light from the stars behind. When the dark clouds chance to occur near one or more bright stars, however, they are illuminated and appear as bright diffuse nebulae. The Pleiades (Figure 111) and the Orion nebula (Frontispiece) are two typical examples of the kinds of bright nebulosities that decorate the sky. An especially rich nebulous region is that centering on the Trifid and Lagoon nebulae, which are separated by but one and a half degrees. The fact that the entire region is strewn with faint nebulous streamers suggests that the two nebulae are physically associated and merely represent two condensations in an extensive cloud of material. It is important to bear in mind that, like the planetary nebulae, the bright irregular nebulae are not self-luminous but derive their brilliance only through the courtesy of the associated stars. The spectroscope reveals that there are two ways in which these aggregations of dust and gas borrow energy from their stellar neighbors. E. P. Hubble of Mount Wilson first noticed that when the surfaces of the exciting stars are cooler than about $18,000^{\circ}$ the spectra of bright nebulosities consist chiefly of dark lines. The similarity between the nebular spectrum and the exciting stellar spectrum leaves little doubt that one is merely the reflec-

tion of the other. On the other hand, when the exciting star is very hot, the main features of the nebular spectrum are strong, bright lines of hydrogen and ionized oxygen. Such emission-line spectra are very reminiscent of the

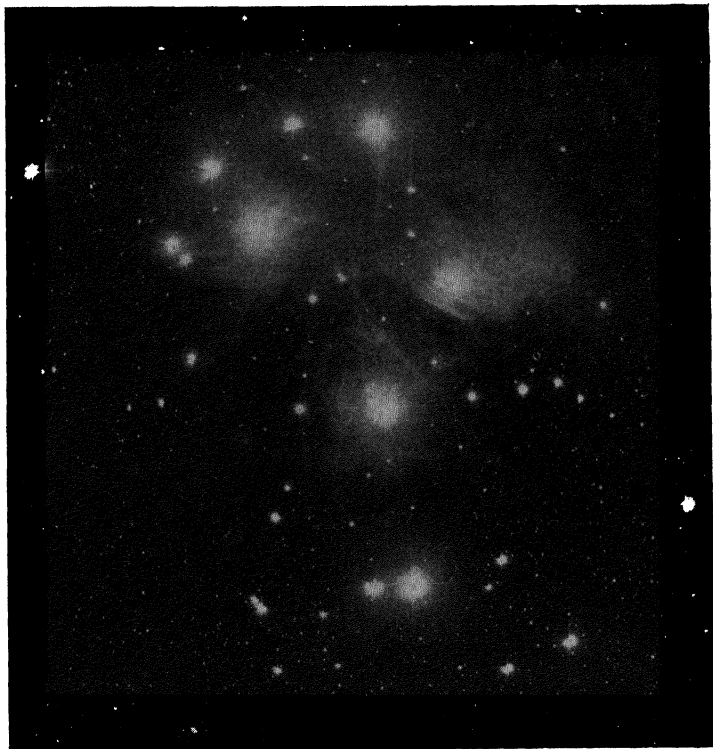

Fig. 111.—Reflection nebulosity in the Pleiades.

(From a photograph taken with the Crossley Reflector at the Lick Observatory.)

spectra of certain planetary nebulae like I.C. 418. The mechanism of light emission must also be similar to that in the planetary, since we are again dealing with a gas of low density, excited by radiation from a hot, distant star.

Bright spectral lines are the trade marks of emission nebulae and enable them to be discovered in all parts of

the Milky Way and even in external galaxies. Perhaps the most beautiful example of an emission nebula in an external galaxy is the Tarantula nebula (30 Doradus) in the Large Magellanic Cloud (Figure 113). The spectroscop



Fig. 112.—The Trifid and Lagoon nebulae.

Two of the most striking gaseous nebulae in the whole sky, the Trifid nebula (above) and the Lagoon nebula (below) are separated by but a degree and a half; they are also probably close together in space. Note the two open star clusters; NGC 6530 above and to the left of the Trifid nebula, and NGC 6531 within the Lagoon nebula. (*Photographed by J. S. Paraskevopoulos with the 24-inch Bruce Telescope at the Harvard Boyden station.*)

has also revealed a number of conspicuous patches of bright nebulosity in the nearby spirals Messier 101, Messier 31, and Messier 33. In Figure 114 we reproduce the spectra of some of the nebulosities in Messier 33, as photographed at the Lick Observatory.

We may visualize the stars as giant spotlights shining on a mixture of fluorescent material (atoms) and reflecting particles (dust). When the spotlight is rich in ultraviolet radiation, the gas fluoresces and bright lines appear. But

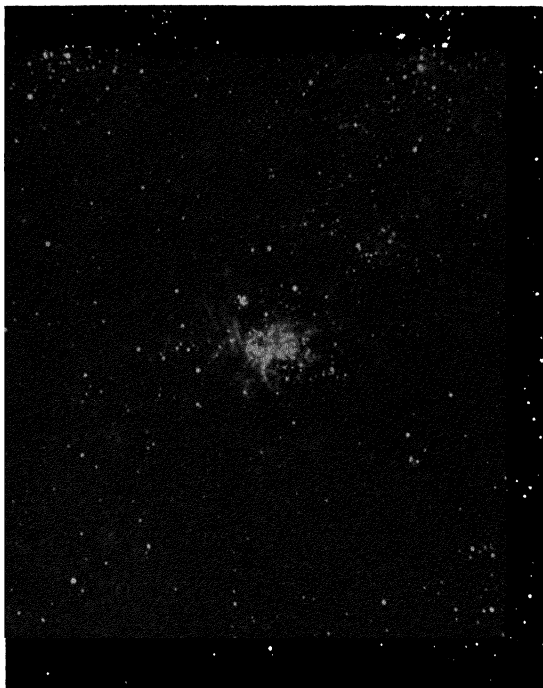

Fig. 113.—The Tarantula nebula—30 Doradus.

(Photographed at the Boyden station of the Harvard Observatory with the 60-inch reflector.)

when only relatively cool stars are present, there is no great store of ultraviolet radiation for the atom to absorb and re-emit in the form of visible bright lines. The starlight falling upon the nebula is then scattered by the dust particles, and the nebular spectrum is simply a reflection of the stellar spectrum. Thus Struve, Elvey, and Roach at

McDonald found the color of a large reflection nebula near the red supergiant Antares to be nearly the same as that of the star. The colors of other nebulae associated with blue *B* stars also were apparently about the same as those of the stars themselves. The Antares nebula covers about one

degree in the sky and must be about five light years in diameter.

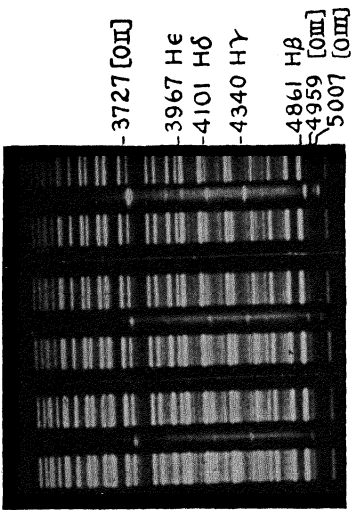

Fig. 114.—The Spectra of some nebulosities in the spiral Messier 33.

(Photographed with the nebular spectrograph attached to the Crossley Reflector of the Lick Observatory.)

Seeliger, in 1893, first considered the mechanism by which light from an illuminating star may be reflected by dust particles. Recently, Henryey at the Yerkes Observatory has extended Seeliger's analysis and has suggested a method for the determination of both the orientation of the illuminating star with respect to the nebula, and its distance from the nebula. The idealized diagram in Figure 115 serves to illustrate the nature of the problem. Consider a thin slab of dust particles, extending at right angles to the line of

sight. For simplicity we shall suppose that the illuminating star is directly in front of the nebula, and ask how the brightness of the nebula will vary across its surface. We may, if we wish, regard the dust particles as so many tiny moons reflecting starlight. The particles just behind the star in the line of sight will be in "full phase," i.e., the complete illuminated hemisphere of each particle faces in our direction. As the angle that each little sphere makes with

the line of sight increases, less and less of the light is reflected in our direction. Finally, the dust particles appear at quarter phase, i.e., only half the reflected light is directed towards the observer. For this reason, and also because the intensity of starlight diminishes as the star's distance from the particles increases, the brightness of the nebula appears to fall away on each side of the center. Henyey also considered the case when the illuminating star is behind the nebula.

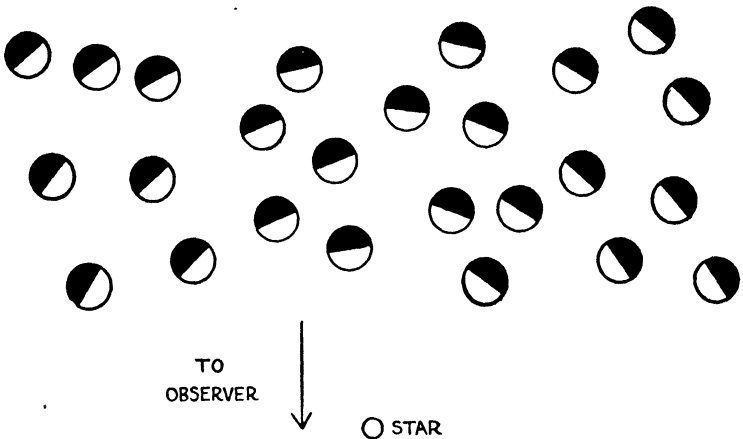

Fig. 115.—The reflection of light by a dust cloud.

For most of the nebulae that are found in the sky the illuminating stars are neither directly in front nor directly in back of the dust cloud, but are found at some intermediate position. From the pattern of illumination of the dust cloud, the spatial location of the stellar spotlight can be inferred. In this manner some separations of several light years between star and nebula have been found.

The theories of Seeliger and Henyey unfortunately apply only to reflection by fairly large particles. The most recent investigations suggest that the majority of interstellar particles do not simply reflect light like tiny moonlets, but rather

scatter it in a more complicated fashion. In fact, most of the light falling upon an interstellar particle is usually thrown forward rather than reflected backwards!

The colors of reflection nebulae are sometimes identical with the colors of their illuminating stars, and sometimes bluer, but never redder. If the nebula is in front of the star, its color will be bluer than the star, for the same reason that the color of the sky is bluer than sunlight. If, on the other hand, the nebula is behind the star, its color will be nearly the same as that of the star.

THE DEPARTMENT OF INTERSTELLAR PARTICLES

Is the interstellar debris the stuff from which the stars are born? As we shall see in the last chapter, there are reasons for believing that the brightest stars have not been shining as long as the sun. Some of our difficulties would be solved if we could suppose that they were created from the interstellar medium.

Before we can build stars out of the dust and gas of space, we must know how these materials interact with one another, how starlight blows them about—problems which have recently been investigated by Lyman Spitzer of Yale. He finds that the dust particles will become negatively charged because electrons will tend to stick to them. Encounters between charged particles and ions and electrons of the interstellar gas tend to distribute the energy around rather evenly. Consequently, the comparatively heavy dust particles move slowly, the lighter atoms and electrons rapidly. Equipartition of energy we call it.

The pressure of radiation may have a considerable effect upon the interstellar particles. Schalén pointed out that the pressure of radiation would tend to drive the dust particles away from a cool supergiant, much as sunlight drives the tail of a comet away from the sun. Near a hot

star, Spitzer finds a less marked repulsion. Hydrogen is then ionized, the electrons cling to the dust particles and therefore make them negatively charged. The whole mixture of dust and protons behaves like a gas and is repelled from the star. The radiation pressure on dust particles is more important than that on atoms, and if the dust and atoms did not interact the dust would be driven away. However, near a hot star, dust and ions do interact and they are repelled together, although less vigorously than if the dust alone were present. We thus find that the interstellar dust and gas are continually being blown about through the effects of radiation emerging from the hot stars that happen to pass close by.

In conclusion we note that there are therefore two good reasons why the astronomer studies the interstellar cloud. First, a knowledge of the composition and properties of "empty" space is important in itself; second, the precise way in which the interstellar material affects the passage of starlight must be learned before we can fully understand the properties and distribution of the stars. The unsolved problems are many. We have yet to learn the composition of the dust particles and why they, together with the gas, tend to collect in clouds. Also the origin of the interstellar medium is still obscure. Has the material come from the stars, or have the stars condensed from the clouds?*

* In his last paper, which confirmed the similarity between the chemical compositions of the planetaries and that of the sun, Wyse announced that the Orion nebula also has the same composition. Presumably the latter has never been part of a star, whereas our present evidence indicates a stellar origin for the planetaries. This result may be of great cosmogonic significance.

D ter Haar of Leiden has recently given a theory for the formation of solid particles of the interstellar medium by direct condensation from the interstellar gas.

STARS WITH EXTENDED ATMOSPHERES

*I*N THE EARLIER CHAPTERS OF THIS BOOK WE HAVE discussed the normal stars and their atmospheres in some detail. An ordinary dwarf like the sun shows a continuous spectrum crossed by dark lines, not unlike that of the great majority of the stars. Certain variable stars, particularly the novae, display bright-line spectra at some stages of their development. In this chapter we shall focus our attention on other, perhaps less spectacular stars, which yet show bright lines.

In his "Astronomical Spectroscopy," published in 1894, Scheiner suggested that bright lines might originate in the spectra of stars with extensive envelopes. We saw in Chapter 8 (Figure 78) how the bright lines in the spectra of novae are accounted for in such fashion. The absorption component is the stronger if the volume contributing to the absorption line is greater than that contributing to the emission line (see Figure 128).

With the exception of the long-period variables, the stars that show bright lines are generally hot objects of spectral

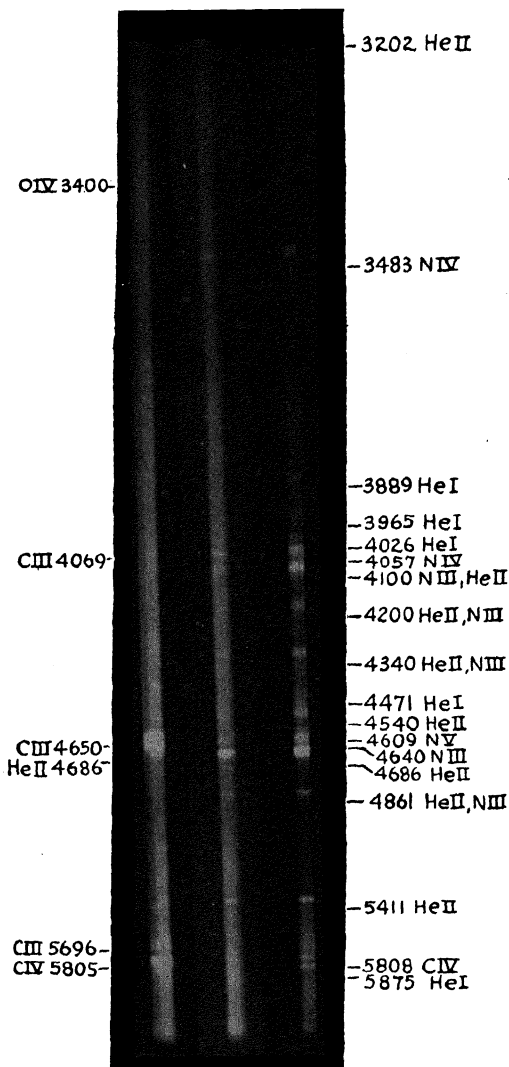

Fig. 116.—Spectra of typical Wolf-Rayet stars.

The star with the widest bands is B.D. +43° 3571 of the carbon-oxygen type. The other two, B.D. +36° 3987 (which has the narrower bands) and B.D. +37° 3821, are nitrogen stars, as is shown by the presence of the NIV 3483 band. (*Lick Observatory.*)

classes *O* or *B*. They apparently possess extensive, turbulent atmospheres, which are expanding, rotating, or pulsating. The stars we shall describe are of two main types:

(a) The *Wolf-Rayet stars* and related objects with expanding atmospheres.

(b) The *B emission stars*, which are hot objects of spectral class *B*, surrounded by a rotating and perhaps sometimes pulsating gaseous shell.

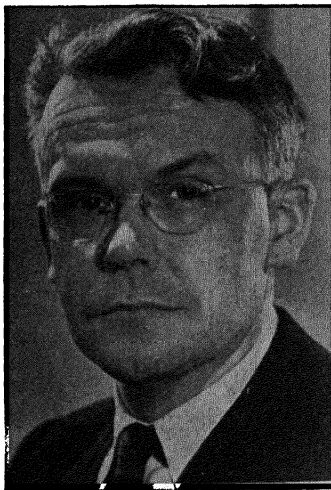

Fig. 117.—C. S. Beals, of the Dominion Astrophysical Observatory, Victoria, B. C. Canada.

THE WOLF-RAYET STARS

The first examples of this strange type of star were discovered visually by Wolf and Rayet, in 1867, at the Paris Observatory. Some idea of their comparative rarity may be gained from the fact that only about eighty are listed among the quarter million stars whose spectra have been classified for the Henry Draper Catalogue.

Generally, the spectra of Wolf-Rayet stars consist of wide, bright lines, about twenty or thirty angstroms wide, superposed on a strong continuous spectrum. In Figure 116 we display the spectra of three Wolf-Rayet stars photographed at the Lick Observatory. Notice that the wide emission lines are sometimes bordered on their violet edges by absorption lines. Ionized atoms of the light elements, helium, carbon, nitrogen, and oxygen, are chiefly responsible for the emission features. The extreme weakness of the hydrogen emission is an almost unique phenome-

non,* especially in view of the great cosmic abundance of hydrogen and its prominence in almost all other celestial spectra.

A promising theory or model of a Wolf-Rayet star, which accounts qualitatively for most of the observed spectral features, was proposed a number of years ago by C. S. Beals of the Dominion Astrophysical Observatory, Canada, and independently by D. H. Menzel, then at the Lick Observatory. The model resembles a miniature planetary nebula, or perhaps a "permanent" nova, consisting of a central star and a relatively large, rapidly expanding, atmospheric envelope. The envelope is continually being replenished by the ejection of atoms from the star.



Fig. 118.—D. H. Menzel of Harvard.

The profiles of the Wolf-Rayet spectral lines may be explained in the same way as those of novae (see Figure 78, Chapter 8). Each spectral line is a composite of radiations from all parts of the envelope. The atoms are streaming radially away from the star in all directions; those at *B* or *H* are approaching the observer; those at *D* or *F* are receding. The combination of the contributions of all these atoms gives through the Doppler effect (Chapter 2) a broad line whose width depends upon the speed of expansion.

The continuous spectrum must originate in the central star, since the gaseous envelope emits a bright-line spectrum.

*The reader will recall that, in the supernovae, hydrogen is also very weak or missing (Chapter 8).

The atoms in the cross-hatched part of the shell will be able to intercept some of the light from the central star and in the process produce absorption lines in its spectrum. Since these absorbing atoms should be moving towards us more rapidly than those in other parts of the atmosphere,

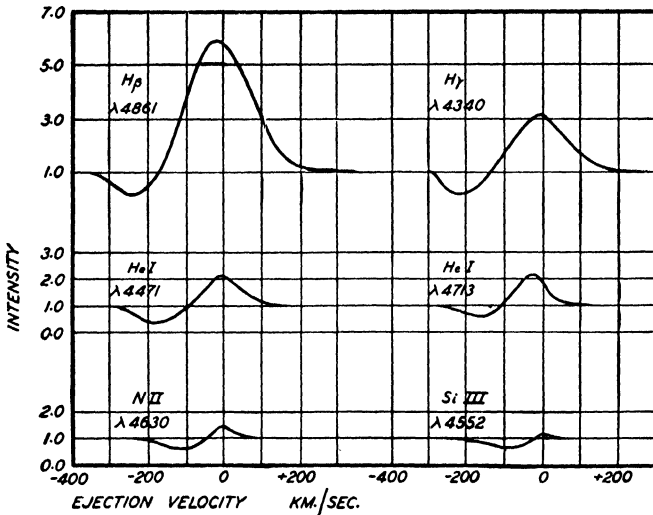

Fig. 119.—Profiles of lines in the spectrum of P Cygni.
(After Beals.)

they will produce dark lines on the violet edges of the emission lines.* From the great widths of the bright lines and the great shifts of the absorption lines on their violet edges, we find that the gases are being ejected at enormous speeds, sometimes as rapidly as 3000 kilometers per second.

The temperatures of the Wolf-Rayet stars are undoubtedly very high.† Beals has estimated them from the

* Note the strong absorption on the violet edge of the helium line at 3889A in the star B.D. +37° 3821, Figure 121.

† It is difficult to estimate their temperatures from the continuous spectra for two reasons. First, as a glance at Figure 121 will show, the over-

intensities of the bright lines with respect to the continuous spectrum. He regarded the Wolf-Rayet stars, for this purpose, as miniature planetary nebulae and applied to them the method of Zanstra and Menzel for the determination of the central temperatures of planetary nebulae.* He finds temperatures ranging from sixty thousand to a hundred and ten thousand degrees. The temperatures, of course, refer to the energy radiated in the far ultraviolet. Another method compares the intensities of two emission lines, c and d , arising from two levels of different excitation potential (Figure 122). The relative populations of C and D will depend on the temperature and hence the relative intensities of c and d may be used to estimate the excitation temperature of the star. In Table 11 we present the results obtained by applying the latter method to a number of ions in two Wolf-Rayet stars.

We see that the temperatures are all high, as would be expected for an O or B star. We also notice that the com-

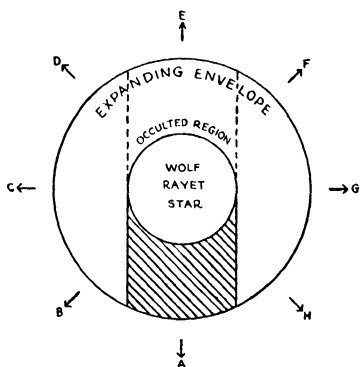

Fig. 120.—The expanding envelope of a Wolf-Rayet star.

As in Figure 79, the arrows indicate the directions of expansion of the gaseous envelope. The cross-hatched area denotes the region of the envelope which absorbs the light of the star and produces an absorption line.

lapping of the broad lines makes it difficult to estimate the intensity of the continuous spectrum. Second, most of the energy is radiated in the ultraviolet, and energy measures in the accessible ultraviolet between 3800Å and 3000Å are very difficult to make accurately because of the variable transparency of the earth's atmosphere.

* See Chapter 9, Page 191.

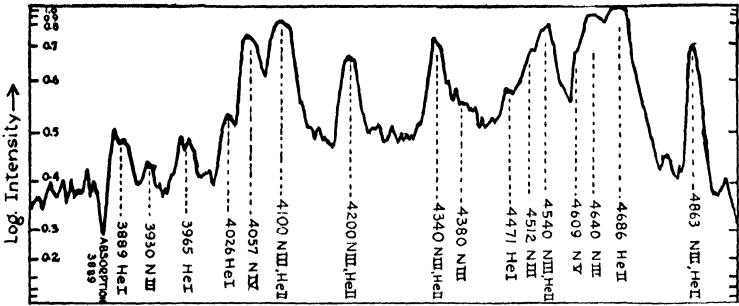

Fig. 121.—Tracing of the spectrum of B.D. +37° 3821.

This microphotometer tracing, which records the blackness of the photographic film, shows the numerous overlapping emission lines in the spectrum of a Wolf-Rayet star. Notice the strong absorption on the He I λ 3889 line.

puted temperature increases for the ions of greater ionization, and therefore greater excitation potential. A possible explanation of this anomaly is that radiation reaches us

TABLE 11
EXCITATION TEMPERATURES OF WOLF-RAYET STARS

Star	Ion*	Ionization potential (volts)	Temperature (absolute degrees)
B.D. +43° 3571	HeII	54.14	18,000
	CIII	47.6	23,000
	CIV	64.2	40,000
	OIII	54.6	28,000
	OIV	77.0	70,000
	OV	113.3	80,000
B.D. +35° 4001	HeII	54.14	44,000
	NIII	47.2	40,000
	NIV	77.0	75,000

* HeII stands for singly-ionized helium, CIII for doubly-ionized carbon, and OV for quadruply-ionized oxygen, etc. See Chapter 3.

from many different layers of the atmosphere. The radiation of the highly-ionized atoms such as OV originates in the hot deep layers, while the radiation of $CIII$ or HeI originates in the higher, cooler atmosphere. * Only in this way may we account for the simultaneous appearance in the same star of lines of NV and HeI . The atmospheres of these stars, in the observable spectral ranges, must be very transparent compared with those of ordinary stars.

The Wolf-Rayet stars were originally classed simply as Oa , Ob , or Oc in the Henry Draper Catalogue, but they differ so greatly in spectral appearance from the normal absorption-line O stars, that they are now assigned the letter W . The Wolf-Rayet stars, however, are not all of one breed. The available spectral evidence proves that there are differences in chemical composition among the mem-

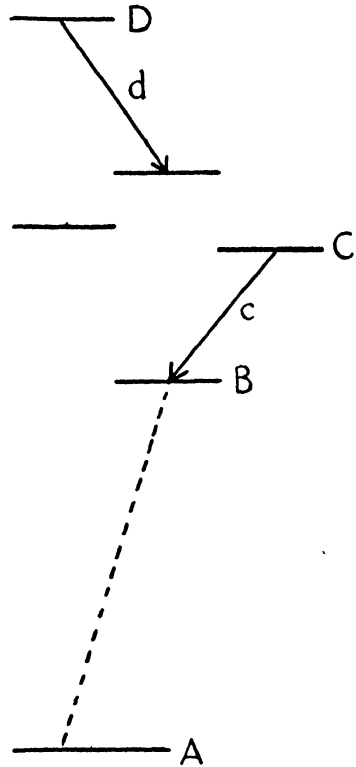

Fig. 122.—Schematic energy level diagram illustrating method of temperature determination for Wolf-Rayet stars.

* Another point of interest is that the lines of highly-ionized atoms are narrower than those of the less-ionized atoms. Since radiations of OV and NV originate deep in the atmosphere and those of HeI or $OIII$ much higher, we may conclude that, as the material is ejected from the star, it is accelerated.

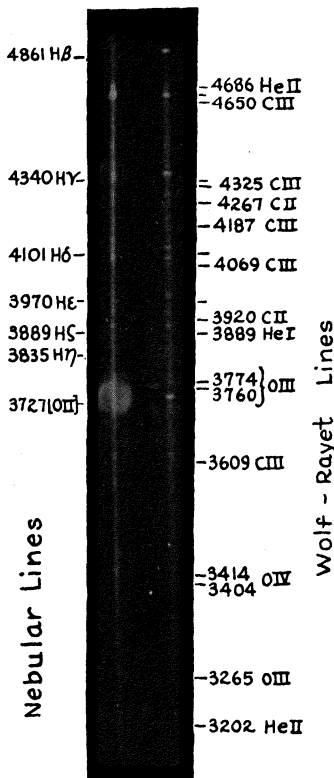

Fig. 123.—*Wolf-Rayet nuclei of planetary nebulae.*

The nuclei of NGC 40 (left) and B.D. +30° 3639 (right) are both Wolf-Rayet stars of the carbon sequence. Radiations originating in the nebulous shell are listed on the left; the Wolf-Rayet lines are listed on the right. The spectrum of B.D. +30° 3639 has been widened by drifting the telescope. (*Lick Observatory.*)

bers of the class.* One group of Wolf-Rayet stars contains objects with oxygen, carbon, and helium, but no nitrogen. The stars in the other group contain nitrogen and helium, with but a trace of carbon. The so-called nitrogen and carbon sequences are designated by the letters *WN* and *WC*. In Figure 116, carbon, oxygen, helium, and nitrogen lines are marked in the spectra of representative stars of each sequence.

The nuclei of planetary nebulae are frequently of the Wolf-Rayet type. Some of the nuclei show the bands of both carbon and nitrogen, while others such as B.D. +30° 3639† or the nucleus of NGC 40 are carbon stars.

The Wolf-Rayet stars are really bright objects. In 1924

* We recall from Chapter 6 that at the lower end of the spectral sequence, the cooler stars were grouped in classes *M*, *N*, *R*, and *S*, depending on their chemical compositions.

† A remarkable feature of B.D. +30° 3639 is that although the nucleus is a carbon star with no apparent trace of nitrogen, "forbidden" [*NII*] lines are very intense in the nebula!

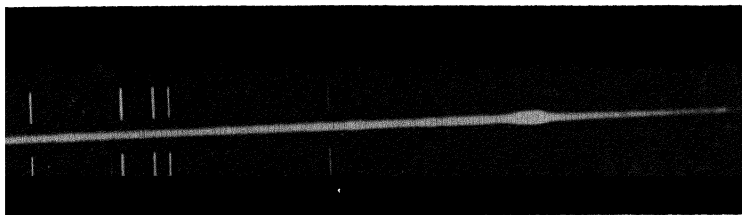

Fig. 124.—The spectrum of *B.D. +38° 4010*,
(Mount Wilson Observatory.)

Miss Cannon reported on a study of 31 Wolf-Rayet stars in the large Magellanic Cloud, for which the distance is known.* These stars have an average absolute magnitude of -4.7 and are intrinsically, therefore, about ten thousand times as bright as our sun. However, in these distant objects, our telescopes pick up only the brighter stars and it is possible that the average Wolf-Rayet star is much fainter.

The galactic Wolf-Rayet stars often show very strong interstellar lines in their spectra, indicating that they are distant, as well as bright objects. Merrill, Sanford, and Olin Wilson, at Mount Wilson, and Beals, at Victoria, have estimated their distances from the interstellar lines. R. E. Wilson has recently estimated the distances of Wolf-Rayet stars from their motions across the line of sight, i.e. their *proper motions*. From all these data he concludes that they are very luminous objects of mean absolute magnitude about -3.4 ; therefore they are about as bright as the normal *O* stars showing absorption lines, two thousand times the sun's luminosity.

From the estimated temperatures and distances of the Wolf-Rayet stars, Beals, in 1940, concluded that their average diameters are about twice that of the sun. Fortunately, additional clues as to the sizes and luminosities

* See H. Shapley, *Galaxies*. The Harvard Books on Astronomy.

of these stars, and our first information about their masses has been unearthed. O. C. Wilson has discovered that four Wolf-Rayet stars are components of spectroscopic binaries. In addition, S. Gaposchkin, at Harvard, has found that one of these, B.D. $+38^{\circ} 4010$, is also an eclipsing binary with a

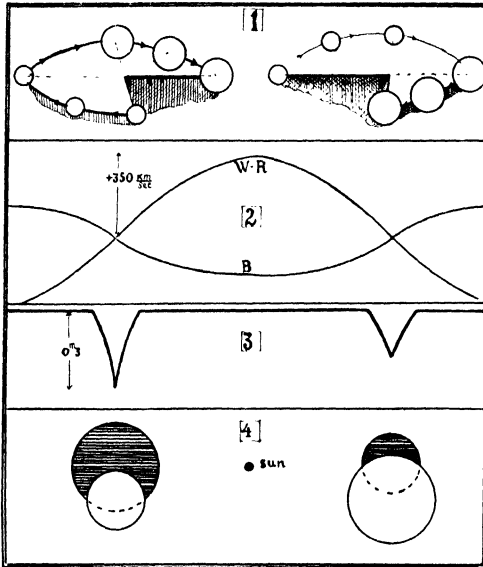

Fig. 125.—The light curve, velocity curve, and orbit of B.D. $+38^{\circ} 4010$.

(1) The motions of the two stars in their orbits. (2) The radial velocity curve. (3) The light curve. (4) The sizes of the stars compared with the sun. (After S. Gaposchkin.)

B-type companion (see Figure 124). We recall from Chapter 1 that, from the light curve of an eclipsing binary, we may calculate the relative sizes of the two components in terms of the radius of the orbit. If the star happens also to be a spectroscopic binary, we can observe the speed of revolution in kilometers per second, and thus fix the size of the orbit

and the dimensions and masses of each of the components. Gaposchkin finds that the Wolf-Rayet component of B.D. +38° 4010 has ten times the mass of the sun and is 230 times as bright. Its radius, six times that of the sun, measures the size out to where the atmosphere becomes sufficiently opaque to dim the light of the *B* star. The transparent region of the atmosphere, where the emission lines are produced, is probably much more extensive. The other component is a *B* star that is twenty-six times as massive and ten times as large as the sun (see Figure 125). The dimensions and masses of other Wolf-Rayet stars are not known at present.*

THE *P* CYGNI STARS

Apparently related to the Wolf-Rayet stars, though generally a bit milder in explosive characteristics, is a small group of stars with bright-line spectra, of which *P* Cygni is the prototype. *P* Cygni itself has had a remarkable history. Apparently, it rose from obscurity in 1600, in nova-like fashion, and then faded somewhat, only to erupt again some fifty-odd years later. It finally settled down as a star of the fifth magnitude.

The present spectrum of *P* Cygni is shown in Figure 126. Note that the emission lines are narrower and less prominent than in the Wolf-Rayet stars, and that the absorption lines are conspicuous. We have reproduced (Figure 119) the profiles of several lines as measured by Beals. The strongest in the spectrum of *P* Cygni are those of hydrogen, which display sharp absorptions on their violet edges, as

* Recently, Wilson, using a light curve by Kron, has derived radii of 18.5 and 11.1, and masses of 12.4 and 31.8 (all in terms of the sun) for the Wolf-Rayet and B components, respectively. He thus finds the Wolf-Rayet star to be the larger and brighter of the pair. The expanding shell hypothesis predicts a phase shift between the velocity curve and the light curve which is not observed. Our models are evidently oversimplified.

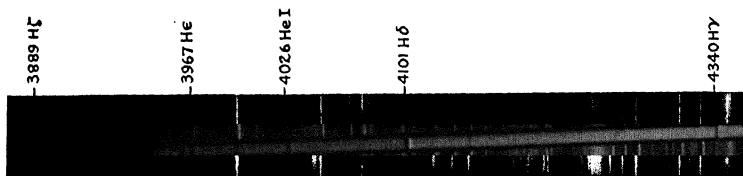

Fig. 126a.--The spectrum of *P* Cygni.
(Perkins Observatory.)

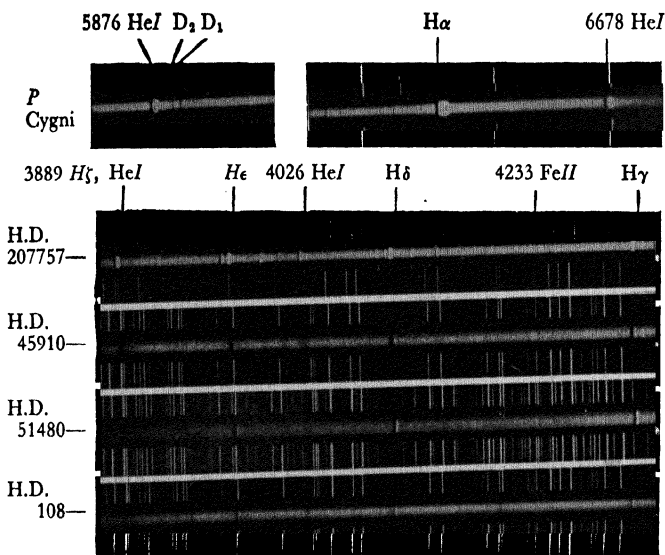

Fig. 126b.--The spectra of stars of the *P* Cygni type.
(After Beals.)

does also the neutral helium line at 4471A. Certain other lines show weak emission or none at all.

There is strong evidence for the stratification of the atmospheres of these stars. Lines of both hydrogen (ionization potential = 13.5 volts) and *NIII* (I.P. = 47 volts) appear in the spectrum; apparently the *NIII* radiations are produced deep in the hot atmosphere and the hydrogen lines arise in the outer parts of the shell. Ions of low ioniza-

tion potential tend to show strong emission lines, while the absorption component is much the stronger in lines of ions

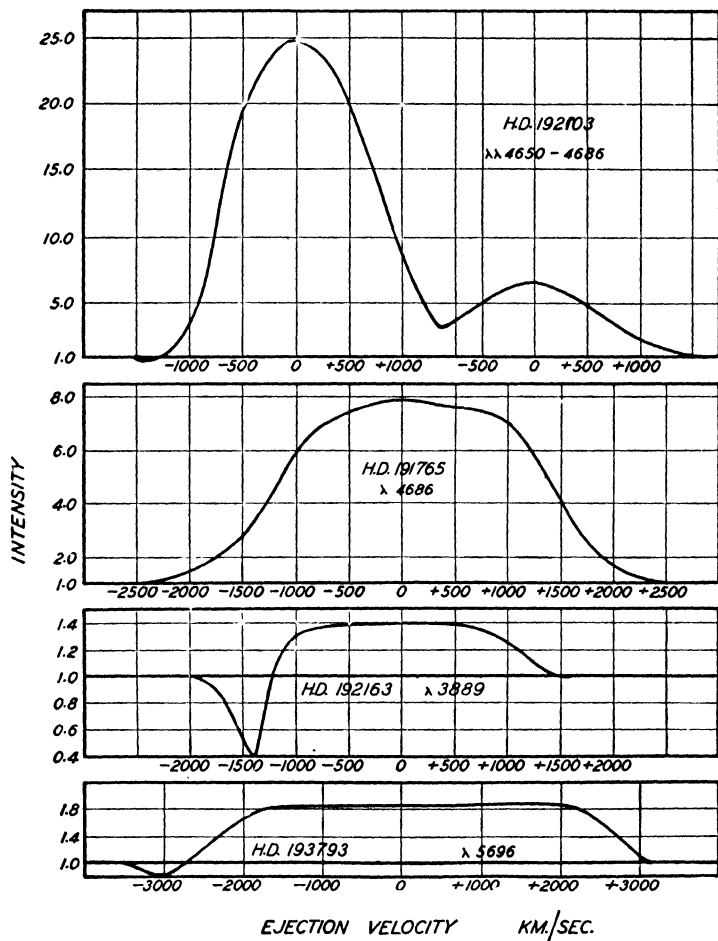

Fig. 127.—Profiles of lines in spectra of Wolf-Rayet stars.

(After Beals, from *Journal Roy. Astron. Soc. Canada*, vol. 34, p. 83, 1940.)

like SiIII. Reference to Figure 128 suggests a possible explanation; the relative volume of the atmosphere con-

tributing to the emission component of the hydrogen lines is greater than the volume contributing to the absorption lines, while the converse is true for *NIII* or *SiIII*. The

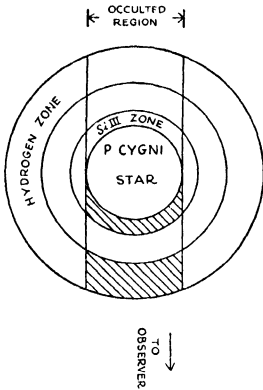

Fig. 128.—The shell structure of *P Cygni* type stars.

The atoms in the shaded regions produce absorption lines, those in the unshaded non-occulted regions produce emission lines. Notice that the region contributing to the hydrogen emission is much greater than that contributing to the hydrogen absorption, while for *SiIII* the reverse is true.

magnitudes and temperatures.

The table includes the remarkable companions of the red variable *Mira Ceti*,* and *R Aquarii* (see Chapter 7).

* The companion of *Mira Ceti* may not be a *P Cygni* star but there seems no doubt about the companion of *R Aquarii*.

velocity of ejection is only about 50 km./sec. in these deeper layers where the lines of *SiIV* and *NIII* are formed, while it amounts to 200 km./sec. in the outer shell where the hydrogen lines are produced.

In *P Cygni* we are apparently given no opportunity to see down to the photosphere of the star. The observations refer entirely to the on-rushing atmosphere, which is so opaque that no light from the photosphere can reach us.

The masses of the *P Cygni* stars are unknown, but rough estimates have been made of their temperatures, absolute magnitudes, and diameters. Table 12, after Beals, gives the distances, apparent magnitudes, absolute magnitudes, spectral types, and the estimated temperatures and diameters of a number of *P Cygni* type stars. Beals estimated most of the distances from the intensities of the interstellar lines, the temperatures from the spectral types, and the diameters from the absolute

Intrinsically these two stars are about as luminous as the sun but their early spectral types (*B8* and *B2*) suggest that they belong to the class of stars that Kuiper calls *sub-dwarfs*.*

TABLE 12
P CYGNI—TYPE STARS (according to Beals)

<i>Star</i>	<i>Dist.</i> <i>parsecs</i>	<i>m</i>	<i>M</i>	<i>Spec-</i> <i>trum</i>	<i>T degrees</i> <i>absolute</i>	<i>Diam.</i> <i>(x sun)</i>
H.D. 108	1,200	7.4	-3.0	<i>O6</i>	40,000	3.8
Comp. σ Ceti	77	10.0	+5.6	<i>B8</i>	14,000	0.18
H.D. 12953	2,500	5.9	-6.1	<i>A2</i>	9,000	71.0
H.D. 13841	1,850	7.2	-4.1	<i>B2</i>	25,000	8.9
H.D. 14134	2,350	6.7	-5.2	<i>B2</i>	25,000	14.8
H.D. 14143	2,500	6.7	-5.3	<i>B1</i>	28,000	14.1
H.D. 14818	2,180	6.2	-5.5	<i>B1</i>	28,000	15.5
H.D. 41511	38	5.0	+2.1	<i>A0</i>	11,000	1.1
H.D. 45910	800	6.7	-2.8	<i>B3</i>	22,000	5.4
H.D. 169454	1,850	6.8	-4.5	<i>B0</i>	30,000	9.3
H.D. 190073	280	7.9	+0.7	<i>A0</i>	11,000	2.1
H.D. 190603	925	5.7	-4.1	<i>B0</i>	30,000	8.1
<i>P</i> Cygni	1,010	5.0	-5.0	<i>B1</i>	28,000	12.3
α Cygni	576	1.3	-7.5	<i>A2</i>	9,000	135.0
H.D. 198478	1,100	4.9	-5.3	<i>B2</i>	25,000	15.5
H.D. 207757	350	7.6	-0.1	<i>B1</i>	28,000	1.3
Comp. <i>R. Aqr.</i>	191	11.0	+4.6	<i>B2</i>	25,000	0.16
H.D. 223385	3,500	5.6	-7.1	<i>A2</i>	9,000	112.0

The normal *P* Cygni stars, on the other hand, are very bright objects, on the average about five thousand times as luminous as the sun. Their diameters as shown in Table 12 are generally several times as great as the sun's. Included in the list are the three supergiant *A* stars, H.D. 12953, Alpha Cygni, and H.D. 223385. Their diameters are of the order of a hundred times the solar diameter, and their

* The sub-dwarf stars, of which only a few are known, fall between the white dwarfs and main-sequence stars in luminosity.

luminosities range up to eighty thousand times that of the sun. These stars, according to Beals, represent an extension of the *P* Cygni type into class *A*.*

The Wolf-Rayet, *P* Cygni, and Alpha Cygni stars have a number of characteristics in common; great luminosities (and presumably high masses), extensive atmospheres, and spectra showing emission lines flanked on their violet edges by absorption. The emission-line intensities and widths and the velocities of ejection are greatest in the hotter stars (Wolf-Rayet type) and gradually decrease as one proceeds to the cooler stars.

Are these stars related to novae? There is some evidence that they may be in certain respects. An examination of the spectrum of a nova at various stages of its development will reveal that near maximum it resembles that of Alpha Cygni; a bit later the spectrum simulates that of *P* Cygni, and finally a nova displays the weak continuous spectrum and strong, broad bright lines of the Wolf-Rayet type. Beals has suggested that novae imitate our stars in yet another way. If the diameters and temperatures of the Wolf-Rayet, *P* Cygni, and Alpha Cygni stars are plotted on a temperature-diameter diagram (Figure 129), the resulting curve is very similar to the one followed by Nova Lacertae in 1936.

The evidence against any real relationships between these stars and novae is, however, more impressive. The stars of the Wolf-Rayet "sequence" are intrinsically very luminous and probably very massive, while novae, when not passing through their temporary phase of high luminosity, seem to be small blue stars, not a great deal brighter than the sun. When a nova explodes, the conditions of tempera-

* In the prototype of these objects, Alpha Cygni, no emission lines are present except for a faint red component to the red hydrogen line, *H α* . Strong, relatively sharp lines of ionized iron, titanium, and chromium characterize this star, while lines of the neutral atoms are very weak.

ture and pressure in the expanding shell may be very similar to those in the atmosphere of *P* Cygni or Alpha Cygni, with the result that the nova spectrum imitates the spectra of the permanent stars. The similarity of these stars in radius and temperature, like the spectral one, is probably fortuitous.

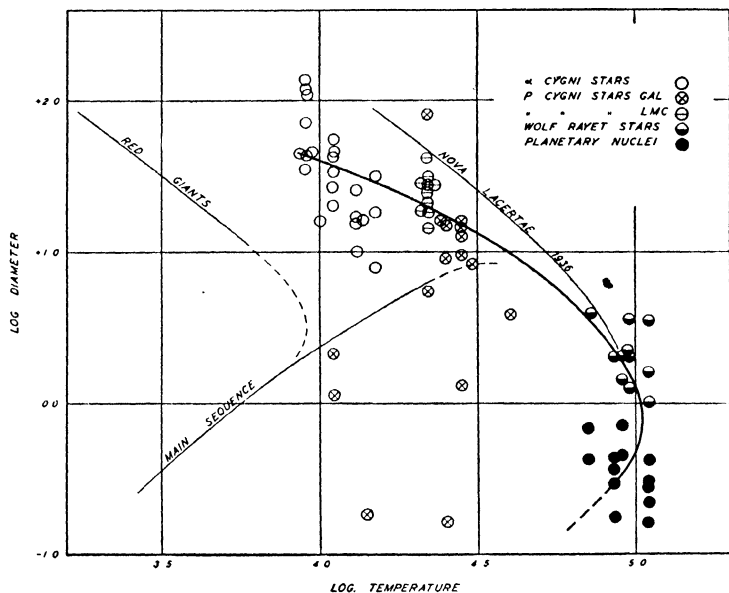

Fig. 129.—The relation between diameter and temperature for Wolf-Rayet stars, *P* Cygni stars and Novae.

(After Beals.)

THE *B* EMISSION STARS

A group of hot stars even more peculiar in many respects than the *P* Cygni and Wolf-Rayet stars, is the *B* emission class. These stars differ from those that we have so far considered in that they apparently retain their gaseous envelopes more or less permanently.

As we have seen, the bright lines in Wolf-Rayet and *P* Cygni stars often show absorption lines on their violet edges. The types of profiles displayed in Figures 79, 119, or 127 are characteristic of expanding shells. The *B* emission stars show, however, quite different profiles (see Figure 130).

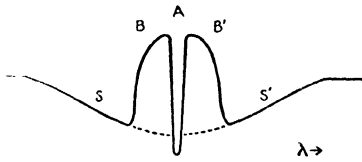

Fig. 130.—Profile of a line in a *B* emission star.

The broad absorption line SS'' is produced by the rapidly rotating star. The emission line BB' is produced by the rotating shell of gas, while the absorption of the starlight by the atoms between the star and the observer produces the absorption line *A*.

Upon a broad washed-out stellar absorption line there appears superposed a narrower emission line, and in the center of this in turn appears a narrow absorption line. Unlike

the profile produced by an ejected mass of gas, the absorp-

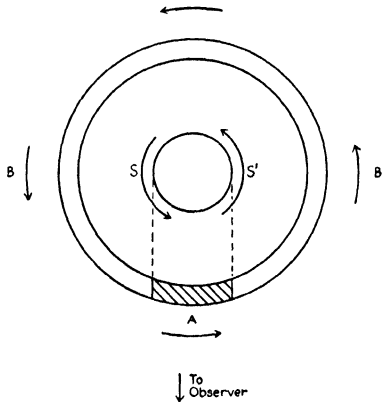

Fig. 131.—Schematic diagram of a rotating star and shell.

The arrows roughly indicate the angular rotation speeds. The atoms in the cross-hatched area *A* absorb the light of the star and produce the central core of the profile of Figure 130. The rest of the shell, except for the occulted region, produces the emission lines. Rotation commonly occurs among normal “dark-line” stars as well as among emission-line stars.

tion line falls in the middle of the emission. Reference to Figure 131 shows how such a spectral line might originate. The broad background line, SS' arises from the rapid rotation of the central star. The limb S of the star (Fig. 131) is approaching us while S' is receding from us. Consequently, an absorption line in the star becomes washed out in the

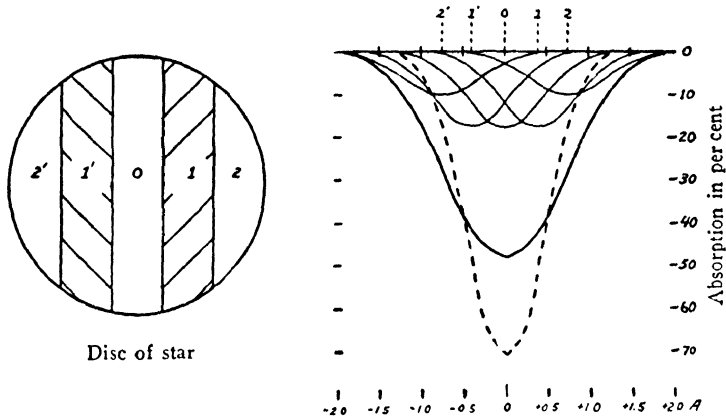

Fig. 132.—The construction of the profile of a line broadened by rotation.

The disk of the star is shown on the left; the axis of rotation is vertical in the plane of the paper. The side 2' is approaching; 2 is receding. The dotted curve on the right is the assumed normal profile. The summation of the separate curves 2', 1', 0, 1, and 2 leads to the rotational profile. (After Struve.)

manner explained in Figure 132, taken from the work of Struve. The surrounding shell or ring rotates more slowly than the star. The atoms in the shaded region A produce the sharp absorption line A of the resultant profile, while those elsewhere in the shell (excluding again the occulted region) produce the emission components BB' . The emission line BAB' is narrower than the broad absorption line SS' because of the slower rotation speed of the shell and smaller Doppler shifts.

The bulk of the observational data on the behavior of the *B* emission stars is due to the work of R. H. Curtiss and his successors, particularly D. B. McLaughlin, at Michigan. They have systematically observed a number of these stars over a period of thirty years.

GAMMA CASSIOPEIAE

The most entertaining of all *B* emission stars is Gamma Cassiopeiae. From 1911 to 1928 this star was constant in brightness and well-behaved. Since then it has gone through three increasingly violent cycles of light and spectroscopic changes. During the course of a cycle, the broad absorption line *SS'* and the emission line *BB'* grows narrow and then widens again as though the speed of rotation of the star varies during a cycle.

Ralph Baldwin, now of Dearborn Observatory, has made an exhaustive study of this star from plates taken at Michigan. He suggested that these changes are due to cyclic variations in the diameter of Gamma Cassiopeiae; in a sense, the outer regions, at least, "pulsate" with a rather long period. Now it is a well-known principle of mechanics that if a rotating body changes its radius, the speed of rotation will change. If a skater, spinning on the ice with his arms

Fig. 133.—The spectrum of Gamma Cassiopeia, showing the bright Balmer lines of hydrogen.

(Mount Wilson Observatory)

outstretched, suddenly folds them, his speed of whirling will increase. Likewise, a rotating star that contracts will speed up; if it subsequently expands, it will slow down.

The widths of the broad absorption lines give a clue to the rate at which the star is spinning and the variations in the width tell how the speed of rotation changes, and therefore how the radius of the star changes. The light curve tells us how the total brightness of the star varies. Measures of the energy in different parts of the spectrum show that the surface temperature of this star also changes in a cyclic fashion. From the observed light curve and computed changes in the radius, Baldwin calculated, according to the methods described in Chapter 4, how the surface temperature should change. The computed temperatures agree, within the errors of measurement, with the observed temperature for the 1936–38 cycle. The radius of the star varied from about ten times that of the sun to eighteen times that of the sun in an interval of five hundred days, and the temperature fluctuated from $13,000^{\circ}$ to 8000° .

BETA LYRAE

Perhaps the best known binary system with an extended envelope is Beta Lyrae. It is apparently an eclipsing system in which the brighter component, of spectral class *B9*, contributes most of the light; hence the spectrum of the fainter component has never been observed. The spectrum of the giant *B9* star shows a regular variation in radial velocity, with a range of 367 km./sec. in a period of 12.9 days. But the remarkable thing about this star is that it shows also an absorption spectrum resembling spectral class *B5*. This spectrum shows little or no variation in velocity during the cycle of the star, although the intensities of the absorption lines do change. Finally there is an emission spectrum, which consists of very broad emission bands of variable intensity

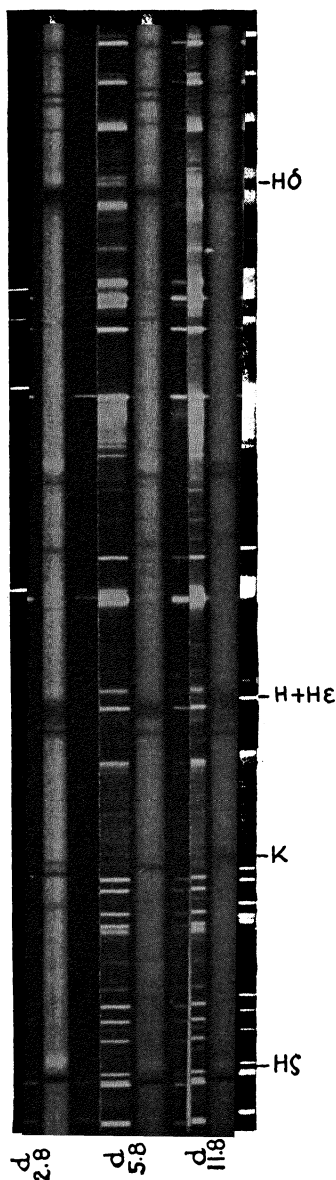

and corresponds to the *B5* absorption spectrum. The complicated spectral changes are exhibited in some Perkins Observatory spectrograms taken at different phases of the cycle (see Figure 134).

A schematic diagram of the system of Beta Lyrae, according to Kopal, is shown in Figure 135. The bright *B9* component has a mass at least fifty times that of the sun, while to

Fig. 134a.—*The spectrum of Beta Lyrae.*

These spectra were taken at phases 2.8^d, 5.8^d, and 11.8^d, i.e. out of eclipse, near secondary minimum (when the bright star is in front), and near primary minimum. The shift of the stellar lines with respect to the comparison spectra on either side is very noticeable. The 2.8 day strip illustrates well the double components, the *B9* component of the line appearing to the violet. The 5.8 day strip (*F*-type star obscured) shows primarily the *B9* spectrum. The shell spectrum is still present but not well separated. The 11.8 day enlargement, taken while primary eclipse was in progress, shows the hydrogen and helium red components which come from the material flowing from the *F*-type star to the primary. (J. A. Hynek, Perkins Observatory.)

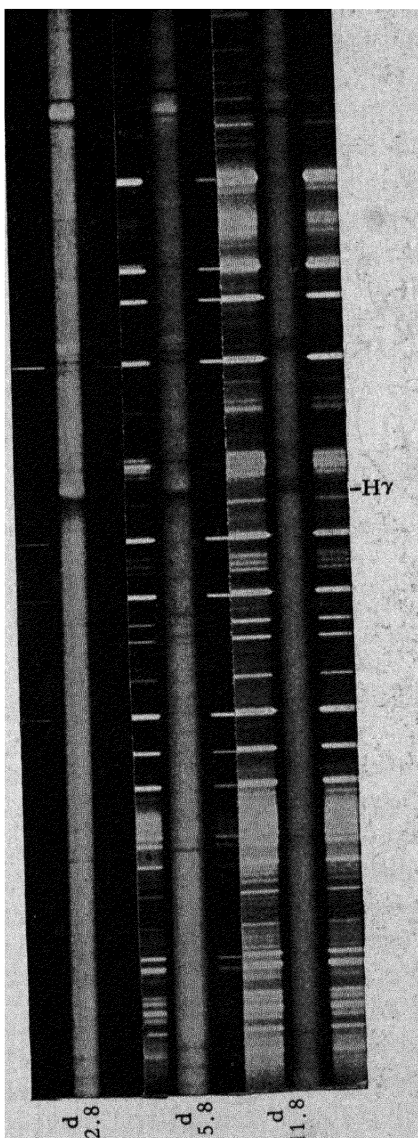

Fig. 134b — The spectrum of Beta Lyrae.

the fainter star which Struve believes is of late *A* or early *F* type, Kopal assigns a mass of at least 43 solar masses. Hence Beta Lyrae is one of the most massive of eclipsing systems.

Struve and Kuiper, of Yerkes Observatory, have proposed a very ingenious interpretation of the complicated spectral changes exhibited by Beta Lyrae. The atmospheres of the two stars are supposed to be in contact so that material

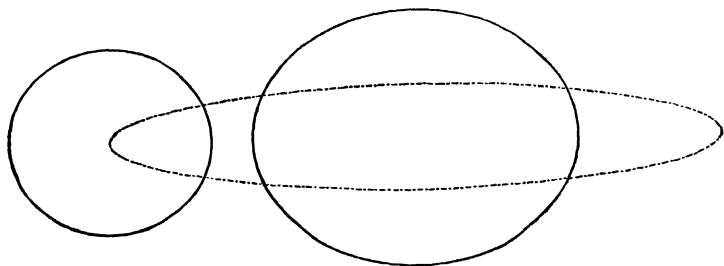

Fig. 135.—The system of Beta Lyrae.

The relative size of the sun is shown in the lower right of the diagram. (After Z. Kopal.)

can flow from one star to the other. The *B5* absorption spectrum was attributed some years ago by Struve to a nebulous mass of gas moving between the *B9* star and the observer. Kuiper showed mathematically that when two unequal stars have a common atmospheric envelope, material streams from the more massive to the less massive star. If the velocity of the stream is sufficient, the gases may not simply return around the fainter star to the primary, but may be ejected into space and spiral gradually outwards.

The model of Beta Lyrae proposed by Struve and Kuiper to account for the complicated spectral changes exhibited by the star is illustrated in Figure 136. The gas streams from the

B9 component outward, some of it spirals around the *F* star and some goes into the shell producing the *B5* spectrum. The first strip in Figure 134 (phase 2.8 days) shows the double components of the lines; the *B9* component appears to the violet. In the second strip (5.8 days) the *F* star is obscured and the *B9* spectrum is the principal one, although the spectrum of the shell is still present. The third exposure (11.8 days) was made at the time of primary eclipse; it shows the red components of the hydrogen and helium lines. These arise from the material flowing from the *F* star back into the primary. Spectra taken just after eclipse show components on the violet side; these arise from material flowing outward from the *B9* star. The spectrum of the *B9* star remains visible during eclipse, since this star is larger than the *F* companion.

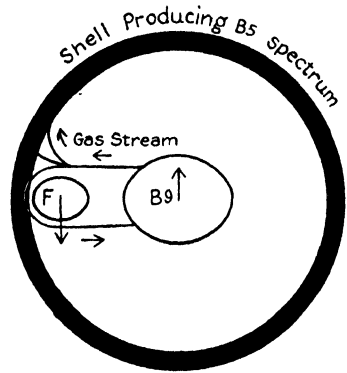

Fig. 136.—Schematic model of Beta Lyrae.
(After Struve.)

Thus, according to the Yerkes model, Beta Lyrae is a massive binary, composed of two very unequal stars whose atmospheres are intermingled. Gaseous material flows from one to the other; some is ejected into space to form an ever-growing ring about the pair. The remainder returns to the primary star.

PHI PERSEI

We shall continue our brief survey of unusual stars with a description of some of the anomalies exhibited by Phi Persei, an object for which no satisfactory physical picture has yet been suggested.

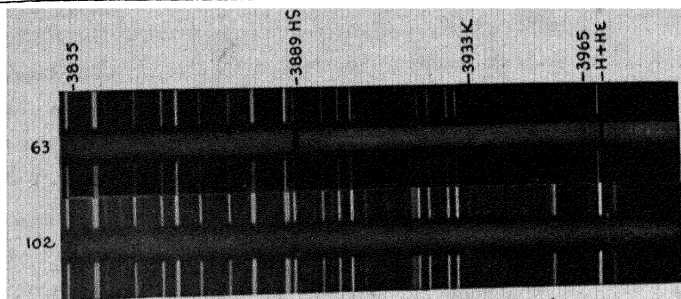

Fig. 137a.—The spectrum of Phi Persei.

Notice that at the phase 63 days the hydrogen and helium lines are relatively sharp while at the 102 day phase they are diffuse. (*J. A. Hynek, Perkins Observatory.*)

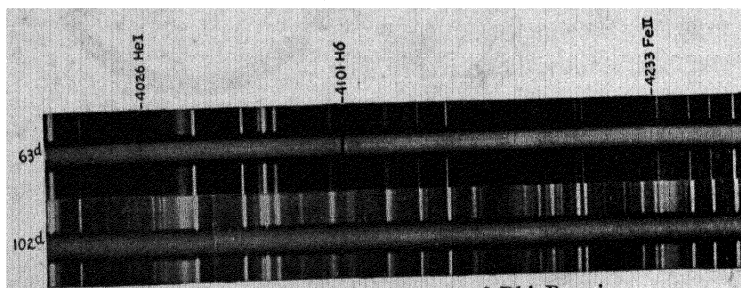

Fig. 137b.—The spectrum of Phi Persei.

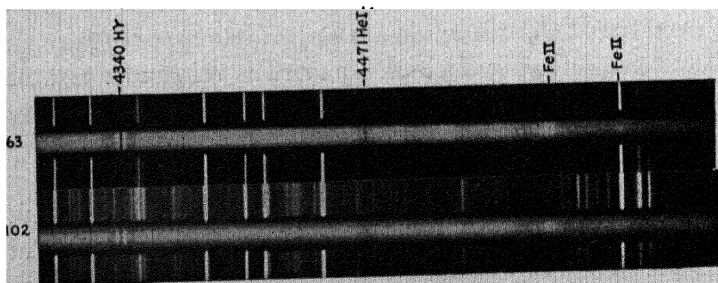

Fig. 137c.—The spectrum of Phi Persei.

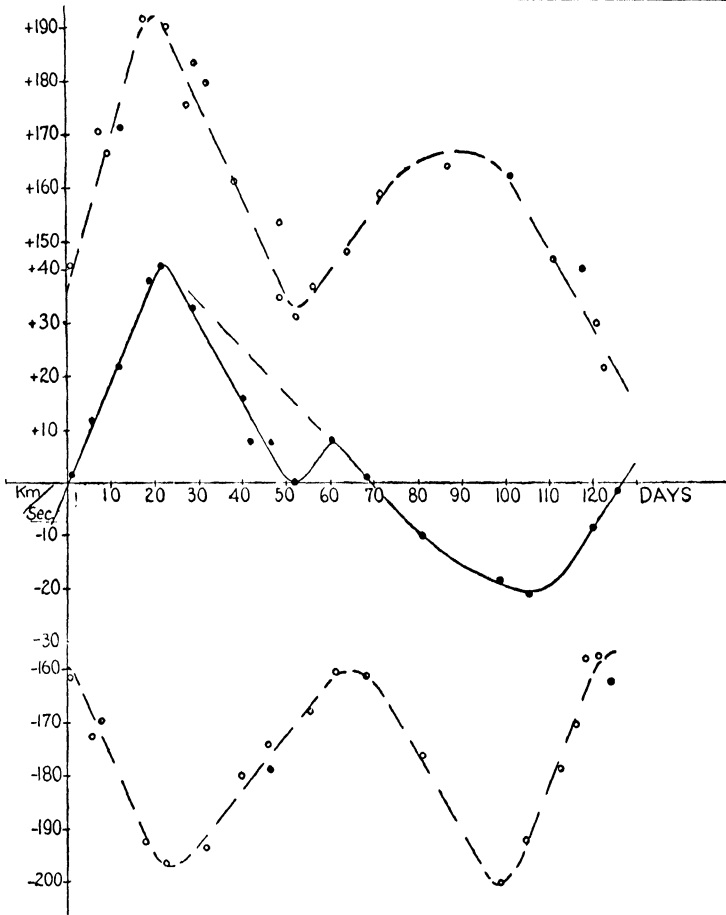

Fig. 138.—The velocity curves of Phi Persei.

The uppermost curve represents the red emission edge of $H\gamma$, the central curve the center core of the line and the bottom curve the violet emission edge. (After Hynek.)

The spectrum undergoes periodic variations in a cycle of 127 days. The star shows no light variations and the changes that take place are in the shifts, shapes, and appearances of the spectral lines. Two spectrograms taken at phases 63

and 102 days are reproduced (Figure 137) from the excellent series obtained by Hynek at Perkins. Let us fix our attention first on the spectrum at 63 days. $H\gamma$ (4340) consists of a broad washed-out absorption line upon which is superposed a bright emission component crossed by a sharp "core." Reference to Figures 130 and 131 shows that this is the type of line that originates in a rapidly rotating star surrounded by a shell of gas. In the higher lines of the Balmer series the absorption core becomes more and more prominent. Lines of helium and ionized iron also appear in the spectrum. At the 102-day phase the lines have become very indistinct; the hydrogen cores are no longer sharp and the helium lines are quite fuzzy.

Hynek has summarized the shifts and changes in emission line width and central absorption cores in Figure 138. The central curve, that of the absorption cores, resembles the curve of a spectroscopic binary, except for the dip, or secondary variation. The other two curves show the changes in width (expressed in velocity units) of the edges of the bright emission components. Notice that the hydrogen emission lines broaden and narrow as the cycle progresses, and go through two cycles while the sharp absorption lines go through one. The broad, washed-out hydrogen lines show no variation in velocity and they may be the superposition of lines from the two stars. The emission and absorption lines of iron, which show but small velocity variations, may arise in a tenuous envelope surrounding the whole system.

The variable spectral features, of which we have mentioned only a few,* seem to admit of no ready explanation. Possibly, Phi Persei is a binary surrounded by a gaseous

* The helium lines show the queerest anomaly. The 3965 line shows a velocity variation very similar to that of the sharp hydrogen cores, but the 4026 and 4471 lines show a velocity curve of opposite phase.

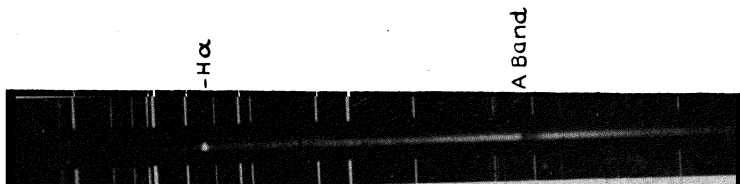

Fig. 139.—The spectrum of Phi Persei in the red and near infrared.

Notice the very strong emission line, $H\alpha$ and the absorption lines due to the earth's atmosphere. (From a spectrogram taken November 19, 1941, by William Petrie with the sixty-one inch reflector at Oak Ridge, Harvard Observatory.)

envelope of material ejected from one or the other or both of the components.*

THE DIMENSIONS OF EXTENDED ATMOSPHERES

We shall conclude this chapter with a brief discussion of a very ingenious method, devised by Struve and Wurm, for estimating the sizes of gaseous envelopes surrounding hot stars. It takes advantage of the fact that certain absorption lines in the observable region of the helium spectrum arise from normal levels, while others arise from metastable† levels. In an ordinary high-temperature stellar atmosphere, all levels, normal and metastable, are substantially populated, but in a detached shell, at some distance from a star, the metastable levels tend to remain populated while the normal levels become depopulated because exciting radiation from the star is so diluted (see page 189).

In Figure 140 we have indicated a number of the energy levels and lines of helium. In an ordinary hot stellar atmosphere, the levels *A*, *B*, *C*, *D* and *E* and the higher ones

* Struve has attributed the irregularity in the velocity curve to the ejection of material from the brighter star.

† See Chapter 9, p. 185.

are populated in accordance with the temperature,* and the various lines appear with their normal intensities. Now levels *B* and *D* are metastable; *C* and *E* are not. Suppose an atom cascades from a higher level into level

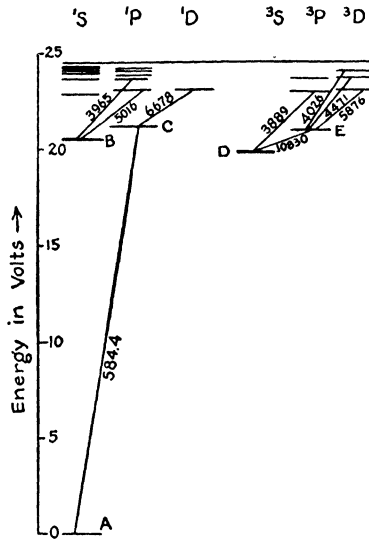

Fig. 140.—Energy level diagram of helium.

The energy is plotted in electron volts. A few of the important helium lines are entered in the figure. Levels denoted by *B* and *D* are metastable; all others are normal levels. The letters 1S , 1P , 1D , and 3S , 3P and 3D designate the different classification of energy levels in accordance with modern spectroscopic usage.

D or *B*. It cannot get to the lowest level, unless it collides with an electron or ion. If the density is low, it will remain there ready to absorb a quantum of radiation corresponding to a wave-length of 3889A or 3965A. An atom that lands in level *E* or *C* will remain there only a fraction of a second before diving to a lower level. Atoms in level *E* will

* The excitation formula relates the population of a level to the temperature. See Appendix G.

emit 10830 and descend to *D*; atoms in level *C* will emit 584 and go to the ground level.

In a normal stellar atmosphere enough radiation is flying about to excite atoms from *A* to *C* and *D* to *E* and to keep these normal levels well filled, but in a gaseous cloud at some distance from a star, the intensity of the 584 and 10830 radiation is cut down considerably; hence the population of levels such as *C* or *E* is also cut down and relatively few atoms are able to absorb lines like 6678, 4471, or 4026. Levels *B* and *D*, from which atoms cannot descend to the ground level by the emission of radiation, are relatively unaffected. Struve and Wurm showed that by comparing the intensities of lines that arise from the metastable levels, e.g., 3965 or 3889, with those that arise from the normal excited levels, e.g., 4471 or 4026, one could estimate how much the exciting radiation from the star had been weakened. In passing from a stellar atmosphere to an extended shell, 4026 and 4471 should weaken considerably with respect to 3965. If the shell is large, the star, as seen from a point in the shell, will fill only a small part of the sky. The smaller the area of the sky the star fills, the smaller the intensity of the radiation. Hence an estimate of the weakening of the radiation should give a clue to the relative sizes of the star and the surrounding shell.

In this way, Struve and his colleagues have estimated the sizes of shells about certain hot stars. Thus the shell about Zeta Tauri is estimated to be about five times the radius of the star itself while the expanding envelope of *P* Cygni is estimated to be two or three times the radius of the star.

The stars with extended atmospheres present numerous puzzling problems for the future. What are the conditions of instability that make a star like *P* Cygni or a Wolf-Rayet object eject its atmosphere? Do these conditions represent

stages in the development of the average luminous hot star or are they shared only by certain peculiar ones? The spinning shells or rings about objects of the Gamma Cassiopeiae type possibly originate from material thrown off from rapidly spinning stars. But we have seen from our discussions of Gamma Cassiopeiae, Beta Lyrae, and Phi Persei that these stars present many other enigmatic problems; why, for example, does the rotational speed of Gamma Cassiopeia vary?

Extended atmospheres seem to be associated with the highly luminous hot stars. They may form a connecting link between the stars and the nebulae, or the stars and the interstellar cloud. Today they are amusing objects for the imaginative astronomer—tomorrow they may provide the keystone for the relation between the stars and nebulae.*

* Further studies of the BD + 38°4010 system have been made by Russell and by Kopal (1944). The latter suggests an O-type primary of 27 solar masses and radius ten times that of the sun with a somewhat smaller Wolf-Rayet component ten times as massive as the sun and surrounded by an immense gaseous envelope which dims the light of the O star when the latter is eclipsed but contributes by itself only a small amount of the light of the system. Tidal distortions of this envelope, produced by the gravitational attraction of the O star are invoked to explain the assymetry of the helium emission lines and their variations in profile as the stars move in their orbits. Kopal concludes that the emission lines of the Wolf-Rayet star originate in the outer portions of its envelope rather than close to the photosphere. Russell discusses the difficulties of deriving precise dimensions of the system and points out that the surface brightness and therefore the temperature of the Wolf-Rayet component is greater than that of the O star. Meanwhile, Olin Wilson and also Albert Hiltner have detected additional Wolf-Rayet spectroscopic binaries. One of these, HD 214419, observed spectroscopically by Hiltner and photometrically by S. Gaposchkin is found to have a Wolf-Rayet component very similar to that of BD + 38°4010. Gaposchkin finds the Wolf-Rayet star to have a diameter about six times and a mass fourteen times that of the sun while the B star has a slightly greater diameter and mass.

12

WHAT MAKES THE STARS SHINE?

*I*N PRECEDING CHAPTERS WE HAVE SEEN HOW THE SURFACE temperature, the atmospheric density, and chemical composition of a star are learned from its spectrum. If we are lucky enough to find that the star is an eclipsing binary system we can also often get its dimensions, total mass, and average density. Since all sorts of stars are found in binary systems, we have a fair idea of the masses, luminosities, surface temperatures, radii and compositions of our celestial neighbors.

From direct spectral studies we obtain rather complete information about the atmosphere of a star, but of the vast bulk of a star, i.e., its interior, we really know very little. Our story would be incomplete, however, if we did not present in this concluding chapter some speculations about the inner parts of stars. We seek to know where originates the energy of radiation, which the stars are so generously pouring out into space, and through what kinds of processes it is produced. In order to answer these questions properly we shall have to consider rather carefully the ways in which

astronomers and physicists have been able to reach in their imaginations to the hearts of stars.

CELESTIAL POWERHOUSES

Our whole cosmogony, all our speculations on the history and future of the physical universe, depends upon the answer to the question: "what makes the stars shine?" The sun, a fairly modest star, generates 5.08×10^{23} horsepower of energy. At the rate of one cent per kilowatt hour, this means that the sun radiates a million million million dollars worth of energy every second. Together, all the stars in the galaxy radiate about a thousand million times as much energy as the sun.

By what kinds of processes do the stars generate so enormous a quantity of energy? How long have the stars been shining and for how long may we expect them to continue to shine? A partial answer to the second question comes, strangely enough, from paleontology. Geology tells us that the age of the oldest rocks in which the fossils of primitive plants and animals are found is about a thousand million years. During all this time the sun must have been shining very much as it is now; for life is a fearfully fragile phenomenon, capable of existing over only a very small range of temperature* between zero and a hundred degrees Centigrade. If the surface temperature of the sun were to change by as much as ten percent, life on the earth would probably be extinguished. What source of energy has enabled the sun to shine so dependably for more than a thousand million years?

An elementary calculation shows the hopeless inadequacy of any ordinary source of power such as chemical com-

* Except for spores, which under certain conditions, may survive higher or lower temperatures.

bustion, i.e. burning. Even if the sun were built of pure carbon, with just enough oxygen present to sustain combustion, it would have burned to ashes in a few thousand years. A more efficient, but still inadequate source of energy is gravitational contraction. As a large, distended body contracts under the pull of its own gravity, the outer parts literally fall toward the center, and the energy of the falling material is converted into heat and light. Helmholtz suggested, nearly a hundred years ago, that an annual contraction of the sun's radius by 140 feet would be sufficient to account for the observed rate of heat liberation. Further calculations show, however, that by shrinking from an almost infinite size to its present dimensions, the sun could shine at its present rate for less than fifty million years. Twenty million years ago the sun would have been at least as large as the earth's orbit, and at that time our planet presumably had life on it.

One very copious source of power, which looks very promising, is the conversion of matter into energy. Early in the present century, Einstein showed that mass and energy were related by the simple equation:

$$E = mc^2,$$

where c is the velocity of light, i.e. 3×10^{10} cm./sec., m is the mass in grams, and E is the energy in ergs. In order to keep the sun shining at its present rate, 4,200,000 tons of material would have to be transformed into energy every second. Yet the sun is so massive that its mass would be thereby diminished by only a tenth of one per cent in 15 thousand million years.

What is the operation by which stars may convert mass into energy? Several possibilities present themselves. First, as with radioactive substances, a small fraction of the mass may be automatically converted into energy. Second, as

in certain laboratory experiments, some atoms may be transmuted with the transformation of roughly one per cent of the mass into radiant energy. The third possibility, that of the conversion of all the matter of some atoms into energy, seems unlikely. Although great progress has been made towards solving this problem in recent years, the reader should bear in mind that present results are only tentative, and will undoubtedly be greatly modified in the near future.

The first and most obvious suggestion is that the stars continue to radiate because they contain a great deal of radioactive material. Experiments in the laboratory show that the disintegration of uranium into radium and eventually into lead is accompanied by the release of considerable amounts of energy in the form of high-speed particles and radiation. The rate of conversion is slow; a pound of pure uranium will be converted into equal parts of lead and uranium in about four thousand million years. But the rate of disintegration is always the same, whatever the nature of the surroundings; we would therefore expect the luminosity of a star that is dependent on its radioactivity to be directly proportional to its mass. The mass-luminosity relation (Chapter 1) shows, however, that the luminosities increase more rapidly than the masses. A star twice as massive as the sun is sixteen times as bright. It is highly improbable that the more massive stars would have been stocked with greater sources of radioactive materials. Furthermore, even a pure uranium sun would not provide enough energy to maintain the theory; we would be forced to postulate the existence of super-radioactive substances.

The second possibility, that of the transmutation of elements, with a bit of the masses of the interacting atoms consumed to provide energy, looks the more promising. Accordingly, we shall look into this possibility.

THE ANATOMY OF A STAR

As is frequently true in science, the answer to our question: "What makes the stars shine?" depends upon the answers to other questions—those relating to the structure of stars and atomic nuclei. The physicist may probe into the nuclei of atoms in the laboratory, but the astronomer can penetrate only the very outermost skin of the star, its atmosphere. The task of exploring the interior of a star is not as hopeless as it seems, however, for the physicist has supplied us with the necessary tools.

Our problem is as follows: Given the mass, luminosity, and radius of a star, and certain laws of nature such as those of gravitation, radiation and gases, what are the densities, pressures, and temperatures at various depths within the star? The fundamental quantities are the mass, the total luminosity, and the radius. The luminosity of a stable star will equal the total rate of energy output in its interior. With a specified radius and luminosity, the surface temperature will adjust itself so that the surface area times the amount of energy radiated per unit area will equal the total amount of energy generated. If a bright star is relatively small, it will have a high surface temperature; if it is large it will have a low surface temperature.

To illustrate, let us suppose that we know not only the mass of a star, but also how the mass is distributed through the interior, i.e., how the density varies from point to point.* There is good evidence that the density increases very rapidly towards the center. In Chapter 7 we saw that a star could be stable only if, at each point in its interior, gas and radiation pressure, which depend on the temperature according to known laws, exactly balance the weight of the

* The actual density variation in stars may be learned from the study of certain kinds of eclipsing stars.

overlying layers. As we go deeper into the star the weight of the upper layers, which we may compute from the law of gravitation, and the way in which the mass is spread throughout the star, increases and so also does the pressure of gas and radiation, which rises as the temperature increases. We see, therefore, how the observed mass, radius and

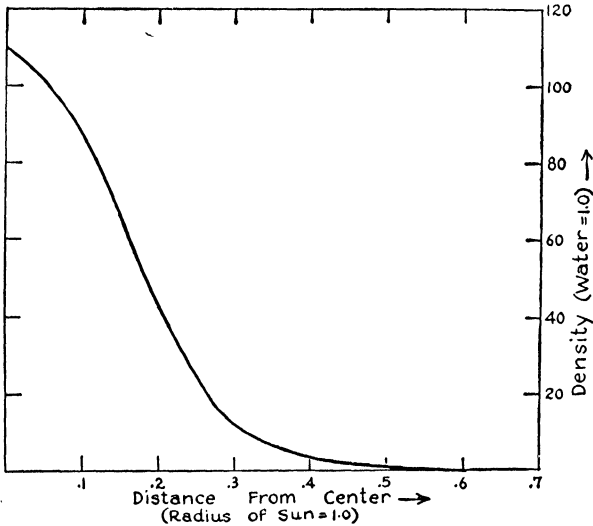

Fig. 141.—The internal density distribution in the sun.

The density (in terms of that of water) is plotted against the distance from the center (in terms of the radius of the sun as 1.0). The molecular weight is 1.0 and the hydrogen abundance 0.35 in this model. (After Blanch, Lowan, Marshak, and Bethe.)

luminosity of the star may enable us to evaluate the pressure, density and temperature everywhere in the interior. In Figures 141 and 142 we illustrate the variation of temperature and density within the sun according to some recent calculations.

From the observed luminosity of the star, we can discover the rate at which it is generating energy, for if the star is

to remain stable, the rate at which energy is radiated at the surface must equal the rate at which it is being released in the interior. If the liberated energy does not escape, but is stored up in some fashion, the mounting pressure of heated gas and radiation will soon cause the star to explode.

Of great importance to the luminosity of a star is its central temperature, since, as we shall see shortly, this temperature determines the rate of energy generation. But the chemical composition of a stellar interior also plays a decisive role, for two reasons: first, because the chemical composition largely determines the transparency, and hence the ease with which energy flows to the surface; second and more important, because the central temperature depends on the composition.

The pressure exerted by a gas is proportional to the temperature and the number, n , of individual particles per unit volume in accordance with the expression

$$p = nkT,$$

where k is the *Boltzmann constant* (see Appendix C), and T is the absolute temperature. In a stellar interior, virtually all atoms are rather completely ionized, and the total number of particles will equal the number of nuclei plus the number of electrons. For a gas composed of neutral hydrogen atoms, the average molecular weight* (total mass divided by total number of particles) is one. But if hydrogen is ionized, there are twice as many free particles with no change of mass, and the molecular weight becomes $\frac{1}{2}$. A completely ionized carbon atom of mass 12 yields 7

* We speak of the molecular weight of a gas even though we are dealing with atoms, for it measures the mass divided by the number of particles, the mass of the oxygen atom being 16.00. In ordinary usage, the molecular weight of a gas is the number of grams of the substance contained in 22,400 cm.³ of volume at atmospheric pressure and 0°C.

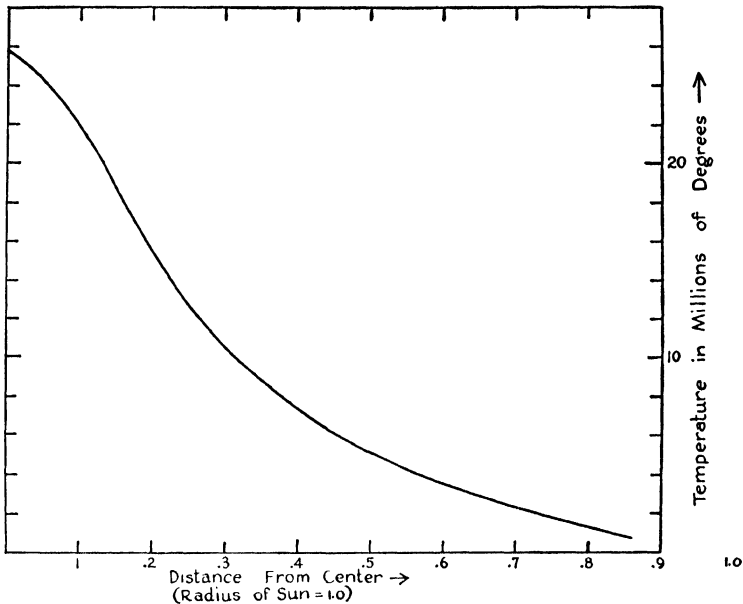

Fig. 142.—The internal temperature of the sun.

The temperature in millions of degrees is plotted against the radius. Notice that the temperature of most of the interior of the sun is greater than a million degrees. (After Blanch, Lowan, Marshak, and Bethe.)

particles, 6 electrons and a nucleus, so its molecular weight is 1.72. Each unit mass of hydrogen contributes two particles, each unit mass of carbon $\frac{7}{12}$ of a particle. A carbon star and a hydrogen star alike with respect to size, mass, and density variation would differ in internal temperature, because the particles of the carbon star would have to work harder, i.e., move faster, than the more numerous hydrogen particles to support the weight of the overlying layers.

Thus the star composed of heavy elements is hotter inside than the hydrogen star. Generally, energy will be generated more rapidly in the star with the hotter interior and it will shine more brightly. As long as its supply of fuel lasted, a

metal star would be about a hundred times as bright as a hydrogen star. If the sun were composed of pure hydrogen, its central temperature would be ten million degrees. The central temperature would be forty million degrees for heavy atoms whereas a pure helium composition would require a temperature of twenty-seven million degrees. Therefore, the chemical composition of its interior will profoundly affect the structure and total luminosity of the star. To determine the chemical composition, the astronomer proceeds by trial and error. He assumes the relative proportions of hydrogen, helium, and heavy elements. With the aid of the known mass of the star, the gas laws, the radiation laws, and the law of gravitation, he calculates how the pressure, temperature and density increase towards the center of the star. From these calculations he obtains the central temperature and the total luminosity of the star. If the latter does not agree with the observed total luminosity, he assumes different chemical compositions and repeats the calculations until the computed luminosity jibes with the observed one.

In this way Strömngren estimated for the sun a central temperature of nineteen million degrees, and a hydrogen abundance of about one-third by weight, provided that the other constituents were mainly heavy elements and not helium.* According to these calculations the central density of the sun is eight times that of mercury and the pressure ten thousand million times that of the earth's atmosphere. Yet the center of the sun must be gaseous because its temperature is so high. Capella and Sirius appear to have the same proportions of

* Recent calculations carried out by Blanch, Lowan, Marshak and Bethe with a model in which the energy is produced entirely in the central region of the star, where the temperature is highest, yield a hydrogen content of 35%, a central temperature of 25.7×10^6 degrees K., and a central density 110 times that of water or 78 times the mean density.

hydrogen as the sun. On the other hand, Zeta Herculis, which has about the same mass and surface temperature as the sun, but is four times as luminous, must have only about one-third the hydrogen content of the sun, again if no helium is present. One of the difficulties in making this type of calculation is lack of knowledge of the relative abundances of hydrogen and helium. Our only source of information here is the stellar atmosphere, where the abundances are likely to be quite different from those in the interior.

If we assume that all stars are built according to the same pattern or model, a number of main sequence stars have the central temperatures given in column 10 of Table 13 (p. 273). For these stars, the computed temperatures range from about thirty million degrees for the hottest objects to about ten million for the faintest ones. Although the central temperatures along the main-sequence vary by a factor of only two or three, the corresponding range in liberated energy is enormous. γ Cygni, whose mass is about seventeen times the sun's, is 30,000 times as luminous. If the stars do shine by the conversion of mass into energy, each gram of γ Cygni must generate nearly two thousand times as much energy as each gram of the sun. The faint component of Krueger 60, on the other hand, with a central temperature of about fifteen million degrees, is 0.007 times as bright, bolometrically, and one-seventh as massive as the sun; hence the star liberates 0.05 as much energy per gram of material.

The giant stars, if built according to the same model as the others, have relatively low central temperatures. Capella, with a density a thousandth that of the sun, has a central temperature of less than six million degrees. Zeta Aurigae, for which the density is seven ten-millionths that of the sun, probably has a central temperature of about

one million degrees, while the central temperature of Epsilon Aurigae is well below that figure.

THE TRANSMUTATION OF THE ELEMENTS

We have seen how, guided by the observed masses, luminosities and diameters of the stars, and by the laws of nature, astronomers have deduced the physical conditions obtaining within a star. In searching for a process that will convert mass into energy, physicists have looked for one that will liberate enough energy at the central pressures and temperatures of the stars to reproduce their observed luminosities. Among the important contributors to the field have been von Weizsäcker, Gamow, Teller, and Bethe.

Some years ago the suggestion was made that the stars shine by converting hydrogen into helium. The atomic weight of hydrogen is 1.00813, and that of helium is 4.00386. Therefore, if four hydrogen atoms could be converted into one helium atom, 0.02866 units of mass, or $\frac{1}{41}$ of the original mass, would appear as energy. The stars of the main sequence probably do shine by converting hydrogen into helium, but the process is not so simple as jamming four protons together to form a helium nucleus. In order to learn the conditions under which the transmutation of elements takes place, we shall turn to the studies of the physicist.

From Chapter 3 we recall that the nuclei of atoms are composed of protons and neutrons. The number of protons determines the charge of the nucleus and therefore the kind of atom; the number of neutrons determines the isotope of the element. We saw, for example, that the ordinary carbon atom of atomic weight 12 has a nucleus consisting of 6 protons and 6 neutrons; the carbon isotope of atomic weight 13 contains 7 neutrons and 6 protons. Chemically, the two atoms are similar.

The heaviest elements, uranium and thorium, spontaneously break down into less heavy atoms, such as radium and meso-thorium, and ultimately into lead. But it is possible, by bombarding with high-speed protons, or helium

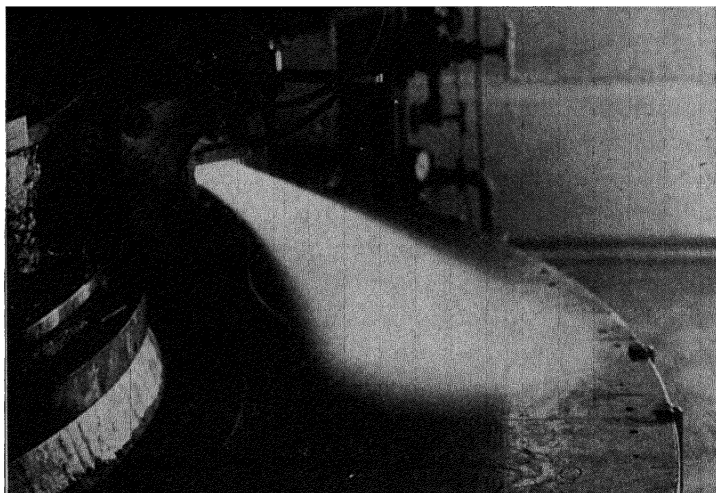

Fig. 143.—The Harvard cyclotron.

The nuclei of hydrogen atoms have been accelerated to a speed of 20,000 miles per second by electrical and magnetic fields within the cyclotron. (*Photograph by Paul H. Donaldson, Cruft Laboratory, Harvard University.*)

nuclei,* or neutrons, to disintegrate other atoms and thus achieve the transmutation of the elements. Devices such as the electrostatic generator or cyclotron (Figure 143), enable the physicist to speed up bombarding particles to enormous velocities and to fire them at atoms.

What kinds of particles are most effective? Protons and helium nuclei are useful only in the bombardment of light

* The helium nucleus consists of two protons and two neutrons held together in a very compact and stable unit. It is frequently called an *alpha particle*.

elements. Positively-charged atomic nuclei repel the similarly-charged protons and helium nuclei, and since heavy nuclei have very large positive charges, they strongly repel the incoming hydrogen or helium nuclei and drive them away before they can penetrate the nucleus. But the neutron possesses no charge and consequently may easily penetrate the heart of any atom.

The physicist obtains neutrons from the heavy isotope of hydrogen, *deuterium*, whose nucleus consists of a single proton tightly bound to a neutron. When heavy water, i.e., water made with heavy hydrogen, is bombarded with deuterium, each pair of colliding deuterium atoms is converted into one helium atom of atomic weight 3 and one neutron.

If we bombard nitrogen (atomic weight 14) with neutrons, we obtain boron (atomic weight 11) and helium (4). We may write the reaction in the form of an equation:

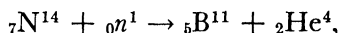

where the superscript denotes the atomic weight and the subscript the charge. Similarly, iron bombarded by neutrons is transformed into a manganese isotope with the ejection of a proton:

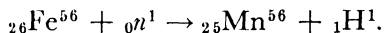

Several possibilities are open when a nucleus is bombarded by a proton. First, the proton may simply remain in the nucleus and produce a new nucleus with a mass and a charge greater by one. Deuterium (heavy hydrogen), when bombarded by protons, yields the helium isotope of atomic weight 3, plus radiant energy:



Second, a proton colliding with a nucleus may be converted into a neutron, with the ejection of a *positive* electron;* the

nucleus retains the same charge but has a greater mass. For example, in the case of hydrogen, a proton-proton collision may form a heavy hydrogen nucleus, consisting of a proton and a neutron:



where the (ϵ^+) stands for the positive electron that is created. The ejected positive electron then encounters an ordinary negative electron, the two annihilate each other and the

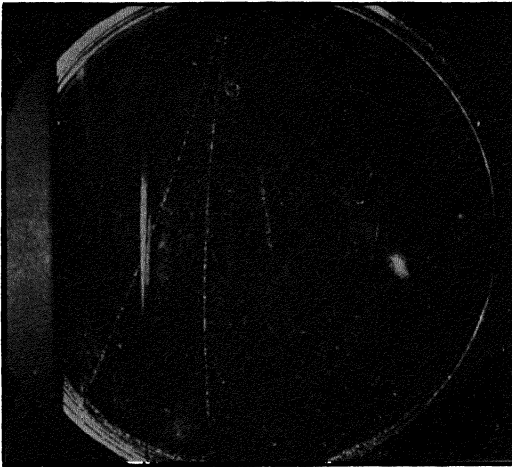
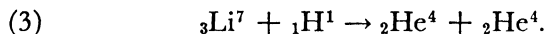

Fig. 144.—Tracks of a negative and a positive electron. (Harvard Physics Laboratory.)

excess energy appears as radiation. Third, the bombarded nucleus may break up into two or more parts, one of which is a helium nucleus. Lithium (atomic wt. 7) bombarded by a proton breaks down into two helium nuclei. The

* A positive electron, or *positron*, has the same mass as a negative electron but a charge of the opposite sign. Dirac predicted its existence from theory, and Anderson at the California Institute of Technology later found it experimentally.

reaction is



The light nuclei of beryllium and boron are particularly vulnerable to proton collisions, as shown by the reactions:

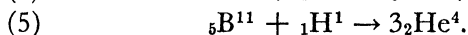

Note that the sums of the nuclear charges and of the atomic weights must be equal on both sides of each equation.

In Figure 144 we show the tracks of a negative and a positive electron in a cloud of saturated water vapor. Water droplets tend to collect about atoms that have become ionized through collisions with fast electrons. These droplets, illuminated and photographed, show the paths of particles which are themselves much too small to be seen. A magnetic field has been applied, so that the path of the negative electron is bent in one direction, that of the positive electron in the other. Figure 145 shows how a particle of high energy, e.g., a proton of a thousand million volts energy, may collide with an atom and produce a host of secondary high-energy particles; these in turn collide with other atoms and produce a shower of high-speed electrons. Particles of such high energy are associated with the cosmic rays.

HOW ENERGY IS PRODUCED IN THE STARS¹

Earlier in the chapter we saw that the internal temperatures of the stars amount to millions of degrees. At such temperatures, the constituent particles are moving about so rapidly that encounters between protons and nuclei should be sufficiently violent to produce nuclear transformations. It is important to realize that the various nuclear transformations do not operate effectively at the

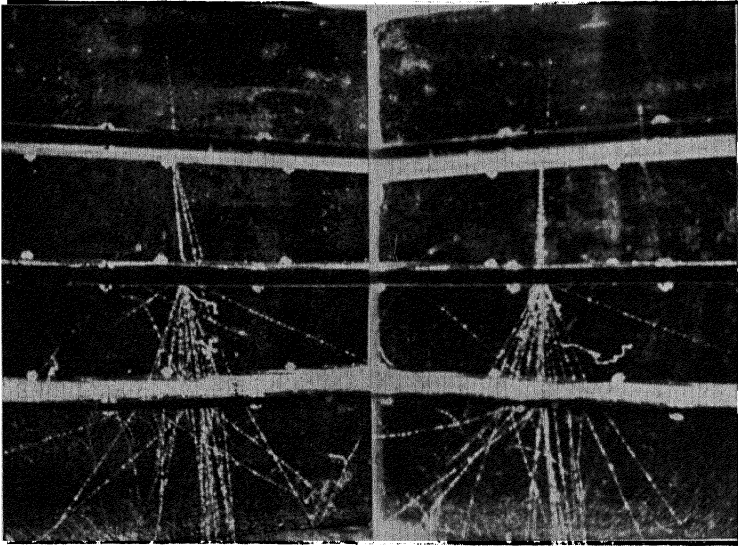
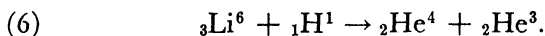

Fig. 145.—Production of secondary particles by a high energy primary particle. (Harvard Physics Laboratory.)

same temperatures. Consequently, a nuclear process responsible for the generation of energy in one star may not work in another star with a different central temperature.

Our present views, which may be subject to considerable revision in the near future, envisage the stars beginning their lives as huge, tenuous, gaseous spheres, slowly contracting under gravitational attraction. At this stage the temperature is so low that nuclear reactions cannot occur. As soon as the temperature rises sufficiently to permit nuclear transformations, enough energy is produced to raise the internal temperature and gas pressure enough to stop the star from contracting further. The first energy-producing reaction to take place is probably the one between heavy hydrogen and protons, equation (1), which can occur at a temperature of $400,000^{\circ}$. Energy will con-

tinue to be liberated until the heavy hydrogen is all gone. The star then again contracts until, when the central temperature rises to about two million degrees, lithium of atomic weight 7 is used up by the reaction (3), while lithium of atomic weight 6 disappears by the reaction



Finally, as the central temperature rises from 3 to 9 million degrees, beryllium and boron are used up by reactions (4) and (5). Gamow, who has done much work on the problem of energy generation at low central temperatures, suggests that certain pulsating variable stars are fed by specific processes;* thus Mira Ceti possibly uses the deuterium reaction, Delta Cephei the reaction (4), and the short-period variables may make use of

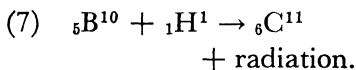

When the light elements, deuterium, lithium, boron and beryllium are gone, the

star contracts once more. The star shines at the expense of energy obtained from its contraction and the central temperature steadily rises until new nuclear sources can be tapped.

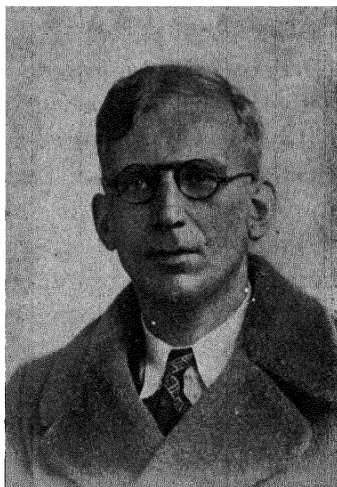
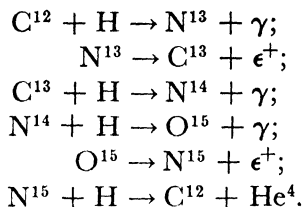

Fig. 146.—George Gamow of George Washington University.

* Recent work of Mrs. Payne-Gaposchkin lends weight to this suggestion, although she finds no star operating on the deuterium reaction.

When the central temperature approaches 18 or 20 million degrees, carbon is transformed and a remarkable process takes place, which leads to the production of helium from hydrogen. The cycle is



Carbon (12) is bombarded by a proton and becomes radioactive nitrogen (13), with the emission of radiation (γ -ray). Nitrogen (13) disintegrates into carbon (13) with the ejection of a positive electron. The next proton collision transforms carbon (13) into ordinary nitrogen of atomic weight 14 with the emission of radiation. Nitrogen atoms, bombarded by protons, emit radiation and become radioactive oxygen of atomic weight 15. The latter is unstable and disintegrates into nitrogen of atomic weight 15, with the ejection of a positive electron. When heavy nitrogen is bombarded with a proton, it splits into an alpha particle and the original carbon of atomic weight 12. By this cycle, four hydrogen nuclei have been converted into one helium nucleus, and the original carbon atom reappears. The carbon, which behaves like a chemical catalyst, can be used over and over again until all the hydrogen has been converted into helium.

The *carbon cycle*, discovered by H. Bethe of Cornell, explains fairly well the luminosities of the stars along the main sequence, i.e., the majority of the stars. In Table 13 we tabulate for a number of main-sequence stars the names, spectral classes, masses, radii, and luminosities, molecular

weight μ , hydrogen content, central temperatures according to the theory of stellar structure, and central temperatures required by the Bethe theory to give the observed rates of energy generation (luminosity/mass). For all of the stars except Krueger 60*B* and YY Gem *A* (Castor *C*),

TABLE 13
THE CENTRAL TEMPERATURES OF MAIN SEQUENCE STARS

Star	Spec- trum	Radius	Mass	Bol. Lumin. $\odot = 1$	L/M	Hydro- gen content X	μ	Den- sity $\odot = 1$	Central tem- peratures in millions of degrees	
		R $\odot = 1$	M $\odot = 1$						Star model T_c	Bethe T_c
Krueger 60 <i>B</i>	M6	0.40	0.14	0.007	0.050	0.22	1.2	2.24	8	17
YY Gem <i>A</i> .	M1e	0.76	0.63	0.069	0.11	0.33	1.0	1.45	16	18
α Cen <i>B</i>	K1	0.87	0.87	0.37	0.43	0.28	1.1	1.32	22	19
Sun.	G	1.0	1.0	1.0	1.0	0.33	1.0	1.0	20	20
α Cen <i>A</i> . . .	G4	1.23	1.10	1.26	1.14	0.37	0.96	0.60	17	21
Procyon . . .	F3	1.7	1.48	5.75	3.88	0.22	1.2	0.31	21	21
Sirius	A0	1.78	2.35	39	16.6	0.40	0.9	0.59	23	22
β Aur <i>A</i>	A0p	2.81	2.40	68	28.4	0.21	1.2	0.11	20	25
<i>U</i> Oph <i>A</i>	B5	3.23	5.36	500	93	0.49	0.8	0.18	26	25
<i>V</i> Pup <i>A, B</i>	B2	6.75	18.5	7,200	400	0.8	0.6	0.06	32	32
Y Cyg <i>A, B</i>	O9	5.86	17.1	32,000	1,900	0.8	0.6	0.085	35	35

the hydrogen contents are taken from the work of Ström-
gren.* If we suppose that the abundance of nitrogen in
the interior of the sun is as much as one per cent, we may
explain the observed rate of radiation by a central tem-

* The model assumed in the calculation of Table 13 is that of Eddington. For this model the central temperature in terms of millions of degrees is given by $T_c = 19.7\mu M/R$, where μ is the molecular weight, which may be computed from the hydrogen content. M and R are respectively the mass and radius in terms of those of the sun.

perature of 20,800,000°. A lower nitrogen abundance will, of course, require a higher central temperature.*

In the cooler stars of the main sequence, those of spectral class *M*, the central temperature is lower, and for these stars Critchfield and Bethe have proposed the cycle;

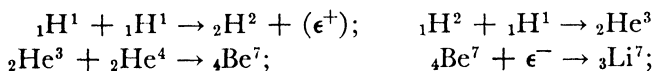

and

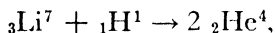

which is probably more important than the carbon cycle. The rate of operation of this cycle varies more slowly with the temperature than does the carbon cycle.†

THE SPENDTHRIFT BRIGHT STARS

Although the carbon cycle apparently explains the generation of energy by the stars of the main sequence, our present theories of stellar energy sources encounter some severe difficulties. A main-sequence star shines by converting hydrogen into helium. To keep on shining at the present rate, the sun, an unassuming dwarf, must convert 564,000,000 tons of hydrogen into 560,000,000 tons of helium every second. The sun has been shining for at least two thousand million years and should continue to shine for about eight or ten thousand million more. On the other

* The carbon cycle encounters a number of difficulties, even for main-sequence stars. The relative abundance of nitrogen and carbon must be nearly the same from star to star if the mass-luminosity relationship is to hold. Also, recent work assigns to the sun a central temperature of nearly twenty-six million degrees, somewhat higher than the twenty or twenty-one million degrees suggested by the Bethe mechanism.

† At a central temperature of about twenty million degrees the production of energy by the carbon cycle varies as T^{18} , whereas the rate of energy generation by the proton cycle is proportional to $T^{3.5}$.

hand, γ Cygni, which is burning up hydrogen a thousand or so times as rapidly as the sun, seemingly cannot last more than about a hundred million years, no matter how we juggle the hydrogen content. If the hydrogen content of γ Cygni is 80%, as Strömngren estimates, it should be only about 35 million years old. But the universe has probably been in very much its present state for about two thousand million years. Therefore, if nuclear reactions are responsible for the energy generation in stars, objects like γ Cygni must either be recent creations or they must have been kept from shining for most of their lifetimes. Stars of great mass and low luminosity, however, are not known.* The mass-luminosity relation seems to be followed rather well by most stars.

We encounter equally great difficulties when we try to explain the generation of energy in the cool giant stars. Capella, if it were constructed like the sun, would have a smaller central density and a central temperature of six million degrees, whereas the Bethe mechanism would require a temperature of thirty million degrees. At such low central temperatures, the only known possible reactions are those involving the terrestrially rare elements: deuterium (heavy

* R. A. Lyttleton and F. Hoyle suggested that these hot stars pick up enough hydrogen from the interstellar cloud to keep them shining at their present rates. One difficulty with this hypothesis is that the density of the interstellar medium would have to be 10^{-22} instead of 10^{-24} gm./cm.³ Such densities may exist in the diffuse nebulae, but it is very unlikely that our value for the general density of interstellar matter can be in error by a factor of one hundred. The studies of Schalén and Spitzer indicate, moreover, that gaseous material would be driven away from a hot star by radiation pressure, rather than pulled in by gravity. The maintenance of radiation by the accretion of interstellar hydrogen would lead ultimately to a vicious circle. The more massive the stars became, by accretion, the more hydrogen they would need to burn, until finally a breaking point would be reached when hydrogen could no longer be supplied fast enough to keep the stars going, and they would burn out or blow up.

hydrogen), lithium, beryllium, and boron. In order to keep these stars going they would have had to be well stocked with these light substances, or some process whereby the light elements could be synthesized would have been necessary. Otherwise, a star beginning life as a tenuous mass would pass quickly through the stages of low central temperature and then enter the phase in which the carbon cycle supplied the energy. In such circumstances we should find a vastly smaller proportion of giant and supergiant stars than actually exists.

A more attractive possibility seems to be that perhaps giant and main-line stars are not built according to the same model, and that, as Chandrasekhar and others have suggested, these cool tenuous giants have small dense cores and enormous atmospheres. We may escape from having to use the deuterium and lithium fuels, but we still run into the difficulty we encountered with the other luminous stars, if these stars have existed since the year two thousand million B.C.

If our ideas concerning energy generation in highly luminous stars are correct, we should expect to catch an occasional star at the beginning of its life, and others that are just coming to the ends of their brilliant careers. The detection of stars which had just condensed or formed in some fashion from the interstellar dust cloud and gas would be difficult. They would be non-luminous at first and noticeable only when they obscured the light of more distant stars. We might catch an occasional one in a binary system with a hot, luminous companion. Perhaps the cool companion of Epsilon Aurigae is a star at the beginning of its life. The red component of *VV* Cephei may well be an example of a star that is just started on its career.*

* It is difficult to see how the ages of the components of a binary system can differ. It is possible that the two components may have advanced

Thought-provoking also is the possibility that the Wolf-Rayet stars, discussed in Chapter 11, may be highly-luminous objects on the downgrade. An analysis of their spectra indicates an abundance of helium, little if any hydrogen. They seem to be stars that have burned up their hydrogen and find no new sources upon which to draw. Gravity would force them to contract and, as they did so, there need no longer be a neat balance between gas and radiation pressure, on the one hand, and the weight of the overlying layers on the other. H. N. Russell has suggested that an increase of radiation pressure in the atmosphere, caused by a rise in temperature of the contracting star, could cause the continuous ejection of material. Perhaps these stars may get rid of a good deal of their mass in this way. Certainly the number of Wolf-Rayet stars is small compared with the total number of highly luminous stars, as we would expect if they represent but a brief phase in a star's life. The nuclei of planetary nebulae, which are systematically fainter than the ordinary Wolf-Rayet stars, may also be luminous stars nearing their end.

We may summarize by saying that the Bethe mechanism has had some success in explaining the source of energy in the ordinary stars like the sun. The lifetimes of these stars, on this hypothesis, are comfortably long compared with the two or three thousand million years assigned to the age of the universe. But great difficulties remain for the red giants and the highly luminous blue stars. We do not know what keeps these celestial power houses running. We have yet to learn whether they are recent creations or whether they have existed in some prestellar form since the beginning of time, or operate on unknown principles.

on the path of evolution at different rates, but such unusual combinations as the long-period variables and the early-type stars sometimes associated with them are not easy to explain.

THE WHITE DWARFS

Let us return to the question: what will happen to a star when it has used up all its hydrogen? After the hydrogen is gone, there appears to be no new source upon which a star may draw, so we would expect it to contract, growing smaller, dimmer, and denser. Theory suggests that stars end their lives as small, extremely dense bodies. Is there any observational evidence to support this view? Cold and

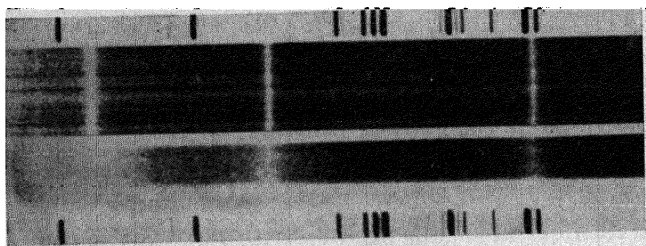

Fig. 147.—The hydrogen lines in the spectra of a normal star and a white dwarf.

The Hydrogen lines are greatly broadened in the white dwarf σ^2 Eridani *B* while they are of normal appearance in the star γ Lyrae (class *B9*). (After *W. W. Morgan, Yerkes Observatory.*)

therefore dark stars would have a small chance of being detected in the galaxy, but some stars are known which may be well on the road to extinction. These are the white dwarfs, whose mean densities are about 100,000 times that of water.

According to the recent lists of Luyten and of Kuiper, about forty such objects are now known. Their absolute magnitudes range from 9.8 to 15.1, corresponding to a brightness range from $\frac{1}{100}$ to $\frac{1}{16,000}$ that of the sun.*

* Luyten has recently announced a remarkable star, of the white dwarf breed, which is the color of the sun but is of absolute magnitude 16.2. Bolometrically, this is probably the faintest known star, $\frac{1}{40,000}$ th as

Their spectra show broad hydrogen lines, partly due to an exaggerated Stark effect. In Figure 147 we compare the spectra of γ Lyrae, a normal *B9* main-sequence star of four or five times the diameter of the sun, with the white dwarf σ_2 Eridani *B*, whose diameter is $\frac{1}{50}$ th that of the sun.

The best known white dwarf is the companion of Sirius, whose mass is about the same as the sun's, but whose diameter is $\frac{1}{45}$ th as great. The average density is 100,000 times that of water. According to some recent calculations of Marshak, the central density may be as high as thirty million times that of water and the central temperature somewhere between seven and fifteen million degrees, depending on whether the interior is composed of helium or of heavier elements.*

Milne and Chandrasekhar have made the most complete studies of the properties of the white dwarf stars. In the highly compressed gas of the interior, electrons and atomic nuclei are probably completely detached and move freely about. Normally, a limit to the compression of a gas, liquid, or solid is set by the circumstance that atoms refuse to interpenetrate one another, i.e., no matter how much we may compress a substance, the electrons of one atom will not penetrate among the electrons of another. In a highly-ionized gas, however, the electrons are detached from the nuclei, so that the substance may be highly compressed. Even a solid collapses under a pressure of 150,000,-000 atmospheres, because the electrons become detached

bright as the sun, a tiny globe five thousand miles in diameter and of unknown, probably prodigious density.

* Theoretical calculations predict a diameter of Sirius *B* less than half that computed from the known temperature and absolute brightness of the star. The theoretical diameter agrees well with the observed diameter for σ_2 Eridani *B*. The cause of the serious discrepancy for Sirius *B* is not known.

from their nuclei, the identities of the individual atoms are destroyed, and nuclei and electrons are tightly jammed together. Such a gas is called a *degenerate* gas; it does not obey the ordinary gas laws. As far as we know at present, white dwarfs have no energy sources other than gravitational contraction, but the companion of Sirius, for example, radiates so little energy that it may continue to shine for another hundred million years.

LOOKING AHEAD

It is unfortunate that we cannot end this book with even a plausible or a half-complete picture of the origin, evolution, and probable fate of the stars and nebulae. On the contrary, our facts and the interpretations based on them run out just where the story becomes interesting. To approach the subject of the age of the universe and its evolution properly, we should have to take up in some detail the description of this galaxy and other galaxies, subjects for other books of this series.

The evidence we have at present from the expansion of the universe,* or the disintegration of star clusters,† indicates that the universe has been in a state resembling its present one for two or three thousand million years. We can give no reason for supposing it cannot go on for some billions more yet to come. Presumably, most of the stars were created, at the beginning of the universe some two or three thousand million years ago and they have been shining ever since.

We have seen that this suggestion meets with difficulty when we consider the hot stars. No known mechanism is capable of explaining the present prodigious energy output of these objects over a period of one billion years, but again

* See H. Shapley, *Galaxies*.

† See Bok and Bok, *The Milky Way*, Chapter II.

we must remember that nuclear physics is a new subject and our ideas of the interiors of stars may undergo severe metamorphoses in the next few years.

Any complete theory of the origin and development of stars must account for all the diverse objects, such as dwarfs, giants, supergiants, pulsating stars, and supernovae, and fit them into a coherent picture. Until this unification of knowledge has been accomplished, our speculations on the evolution of stars are likely to be little more than scientific day dreams. We can, of course, say what the future of the sun is likely to be if the Bethe mechanism is right and our notions about the interiors of stars are not too greatly in error. It may not be too drastic a flight of fancy to describe the sun's possible future and the possible end of the world in the following terms:

Hydrogen will be converted bit by bit into helium and as this process goes on the internal temperature should rise and the sun should become brighter and hotter. This means that in the aeons to come the sun should imperceptibly wax larger and brighter and the earth should become warmer at the rate of a small fraction of a degree every million years. We may envisage the day when finally the oceans will boil and life will disappear from a scorched and dried-up planet. Eventually, some eight or ten thousand million years hence, the sun should be a good deal brighter than Sirius is now, but such glory must be ephemeral. With its hydrogen gone, it should fade quickly and become a white dwarf, there to linger perhaps for a brief hundred million years before passing on to its celestial grave.

APPENDIX

- A.* The Greek Alphabet
- B.* Relations Between English and Metric Units
- C.* Some Physical Quantities and Relationships Useful in Astronomy
 - 1. Definitions and units of force, energy, and power
 - 2. Some relations concerning gases, pressure, density, and temperature
 - 3. Definition of charge in the Electrostatic system
 - 4. Table of physical constants
 - 5. Radiation Laws—definition of black body
- D.* Astronomical Constants
- E.* Stellar Magnitudes
 - 1. The kinds of magnitudes
 - 2. Relation between absolute magnitude, radius, and temperature of a star
 - 3. Relations between magnitudes, color indices, and bolometric corrections
 - 4. Tables of bolometric corrections
 - 5. Relation between apparent and absolute magnitudes
- F.* List of Planetary Nebulae for Small Telescopes
- G.* The Ionization and Excitation Formulæ
 - 1. The meaning of thermal equilibrium
 - 2. The excitation (Boltzmann) equation and its application
 - 3. The ionization (Saha) equation—examples

APPENDIX A

THE GREEK ALPHABET

α	Alpha	ν	Nu
β	Beta	ξ	Xi
γ	Gamma	\omicron	Omicron
δ	Delta	π	Pi
ϵ	Epsilon	ρ	Rho
ζ	Zeta	σ	Sigma
η	Eta	τ	Tau
θ	Theta	υ	Upsilon
ι	Iota	ϕ	Phi
κ	Kappa	χ	Chi
λ	Lambda	ψ	Psi
μ	Mu	ω	Omega

APPENDIX B

RELATIONS BETWEEN ENGLISH AND METRIC UNITS

IN THIS BOOK WE HAVE GENERALLY PREFERRED TO USE metric units—the *centimeter* as the unit of length, the *gram* as the unit of mass, and the *second* as the unit of time. These quantities constitute the c.g.s. system of units. We tabulate here the relations between the more frequently used metric and English units.

1 inch	=	2.54 cms.
1 meter	=	39.37 inches
1 kilometer	=	0.621 miles
1 mile	=	1.609 kms.
1 liter	=	1000 cm. ³ = 1.06 qts.
1 cubic inch	=	16.387 cubic cms.
1 ounce	=	28.35 grams
1 kilogram	=	2.20 lbs. (avoird.)

We use the *Kelvin* or absolute temperature scale. Zero degrees Kelvin is $-273^{\circ}\text{C}.$; hence $273^{\circ}\text{K}.$ is 0° Centigrade or 32° Fahrenheit.

In expressing a very large number like 30,000,000,000 or a very small one like 0.000,000,000,1, we write 3×10^{10} in the first case (i.e. 3 followed by ten ciphers) and 1×10^{-10} in the second case, one divided by ten thousand million (i.e. $\frac{1}{10^{10}}$). Thus, 1.71×10^{-16} means 1.71 divided by 10^{16} .

APPENDIX .C

SOME PHYSICAL QUANTITIES AND RELATIONSHIPS USEFUL IN ASTRONOMY

1. DEFINITIONS AND UNITS OF FORCE, ENERGY, AND POWER

IN VARIOUS CHAPTERS WE HAVE HAD OCCASION TO REFER to force, energy, and power; we shall attempt to summarize here the relations between these various physical entities.

Acceleration is the rate of change of velocity. If velocity is expressed in centimeters per second, acceleration is expressed as centimeters per second per second. The gravity at the surface of the earth may be expressed as 980 cm./sec./sec. which means that the velocity of a freely falling body is increased 980 cm./sec. every second of its fall.

Force is defined as mass times acceleration and the unit of force in the c.g.s. system is the *dyne*. A force of one dyne will give a mass of one gram an acceleration of one cm. per second per second. The force of gravity upon objects at the earth's surface is 980 dynes per gram of mass.

A force of one dyne acting over a distance of one centimeter will give one *erg* of work or energy. Since the erg is

a very small unit of energy, we often use the *joule*; one joule is equal to 10^7 ergs. The *mechanical equivalent of heat*, i.e., the amount of work, which, upon being converted into heat, is sufficient to raise the temperature of one gram of water one degree is 4.185 joules or 4.185×10^7 ergs, or one calorie.

Pressure is force per unit area and is usually measured in dynes/cm.², or in *atmospheres*. One atmosphere of pressure is 1,013,246 dynes/cm.² It is equivalent to the pressure exerted by the weight of a column of mercury 760 millimeters long at 0° Centigrade.

The rate of doing work is called *power* and is expressed in horsepower, watts, or kilowatts. One *watt* of power is equivalent to the deliverance of one joule, or 10^7 ergs, of work per second. A *kilowatt*, of course, is a thousand watts and amounts to a work rate of 10^3 joules/sec. or 10^{10} ergs/sec. A *horsepower* is equal to 746 watts.

2. SOME RELATIONSHIPS CONCERNING GASES

The pressure of a gas, which is the force it exerts per unit area on the walls of its container, is related to the mass of the gas, the volume in which it is enclosed, and the temperature.

Standard conditions of temperature and pressure are 0°C. or 273°K. and one standard atmosphere or 760 mm. of mercury pressure. Under standard conditions, 22.415 liters of a gas will weigh μ grams, where μ is the molecular weight, 28.02 for molecular nitrogen N₂, 32.00 for O₂, for example.

The *gas law* is

$$PV = RT,$$

where T = temperature in absolute degrees,

V = volume in cm.³ occupied by one mole, or μ grams, where μ is the molecular weight,

R = 8.314×10^7 ergs/degree/mole,

P = pressure in dynes.

The gas law is frequently written in the form;

$$p = nkT,$$

where p is the pressure in dynes/cm.², n is the number of atoms or molecules per cm.³, and k is *Boltzmann's constant*.

$$1.380 \times 10^{-16} \text{ erg/deg.}$$

Example.—If the electron pressure in the atmosphere of the sun is 30 dynes/cm.², and the temperature is taken as 5700°, what is the number of electrons/cm.³? We have

$$30 = n \times 1.380 \times 10^{-16} \times 5700^\circ,$$

whence

$$n = 3.82 \times 10^{13} \text{ electrons/cm.}^3$$

The *most probable velocity* of an atom or molecule of mass M at a temperature T is given by;

$$v_0 = \sqrt{\frac{2kT}{M}},$$

where M is the mass of the atom or molecule in grams, T is the temperature in absolute degrees, and k is the Boltzmann constant.

Example.—What is the most probable speed of oxygen atoms (atomic weight 16.00) at a temperature of 10,000°K.? Now

$$M = 16.00M_0,$$

where M_0 is the mass of the hydrogen atom, 1.673×10^{-24} grams; hence

$$M = 2.68 \times 10^{-23} \text{ grams.}$$

$$v_0 = \sqrt{\frac{2 \times 1.380 \times 10^{-16} \times 10^4}{2.68 \times 10^{-23}}} = 3.21 \times 10^5 \text{ cm./sec.}$$

or about three kilometers/second.

3. DEFINITION OF CHARGE IN THE ELECTROSTATIC SYSTEM

Similarly charged bodies repel, oppositely charged bodies attract each other. Suppose two small insulated bodies (pith balls are often used in such experiments) are similarly charged and placed a distance r cm. apart in vacuum. They will repel each other with a force, given by *Coulomb's law*;

$$F = \frac{q_1 q_2}{r^2},$$

where q_1 is the charge of the first body,

q_2 is the charge of the second body,

r is the distance between their centers (expressed in cms.),

and F is the force in dynes.

If r is 1 cm., $q_1 = q_2$, and F is 1 dyne, the amount of charge q_1 or q_2 is one *electrostatic unit*.

4. TABLE OF PHYSICAL CONSTANTS (AFTER BIRGE, 1941)

Velocity of light	$c = 2.99776 \times 10^{10}$ cm./sec.
Constant of Gravitation	$G = 6.670 \times 10^{-8}$ dyne cm. ² /gram ²
Volume of a Mole (0°C.)	22.4146×10^3 cm. ³
Standard Atmosphere (pressure)	1,013,246 dynes/cm. ² /atmos.
Melting Point of Ice	273.16°K. (absolute scale)
Mechanical Equivalent of Heat	4.185 joules/caloric
Acceleration of Gravity	$g_0 = 980.665$ cm./sec./sec.
Density of Oxygen Gas (0°C.)	1.429×10^{-3} grams/cm. ³
Avogadro's Number (number of atoms or molecules per mole)	$N_0 = 6.023 \times 10^{23}$ /mole
Loschmidt number (number of atoms or molecules per cm. ³ at 0°C. and 1 atmos. press.)	$n_0 = 2.6870 \times 10^{19}$ /cm. ³
Electronic charge	$e = 4.8025 \times 10^{-10}$ electrostatic units
Electronic mass	$m = 9.1066 \times 10^{-28}$ grams
Mass of proton	$M_p = 1.67248 \times 10^{-24}$ grams
Mass of hydrogen atom	$M_H = 1.6734 \times 10^{-24}$ grams

Ratio:

Mass proton/Mass electron . . . $M_p/m = 1836.5$
Gas constant per mole $R_0 = 8.31436 \times 10^7$ erg/deg./mole
Boltzmann constant $k = R_0/N_0 = 1.38047 \times 10^{-16}$ erg/deg.
Planck constant $h = 6.624 \times 10^{-27}$ erg sec.
Rydberg constant for hydrogen . $R = 109677.58$ cm. ⁻¹

5. THE RADIATION LAWS

In Chapter 4 we explained how the astronomer measures the temperature of a star by studying;

(a) The distribution of radiation intensity with respect to color or wave-length (application of Planck's law).

(b) The wave-length of the position of maximum intensity (application of Wien's Law).

(c) The amount of energy radiated per unit area of the surface (application of Stefan's Law).

These laws refer to the emission of energy by perfect radiators. In 1859, Kirchhoff showed that for any temperature, *the ratio of the emissive power of a body to its absorptivity is a constant for all objects and equals the emissive power of a black body*, i.e., one that absorbs all the radiation that falls upon it. It is a matter of familiar experience that dark-colored objects are much better absorbers of heat than light-colored ones, and they are also much better emitters of energy. No perfectly black surface has been produced but it is possible to realize experimentally the essential conditions of a black body, insofar as we wish to study radiation (see Richtmyer, "Introduction to Modern Physics," p. 196, 1934, McGraw-Hill).

Planck's law gives the relation between the intensity in a frequency interval, $\Delta\nu$, at ν , for a temperature T , in a unit solid angle (there are 4π solid angles in a whole sphere), as

$$I_\nu \Delta\nu = \frac{2h\nu^3}{c^2} \frac{1}{e^{\frac{h\nu}{kT}} - 1} \Delta\nu,$$

where h is Planck's constant, k is the Boltzmann constant, and c is the velocity of light. If we want the amount of radiation flowing over all directions we multiply this expression by 4π ; to compute the energy density we multiply $I_\nu \Delta\nu$ by $4\pi/c$. If we wish Planck's law in wave-length instead of in frequency units, we make use of the relations

$$\nu = \frac{c}{\lambda} \quad \text{and} \quad \Delta\nu = \frac{c}{\lambda^2} \Delta\lambda,$$

and obtain

$$I_\lambda \Delta\lambda = \frac{2hc^2}{\lambda^5} \frac{1}{e^{\frac{hc}{\lambda kT}} - 1} \Delta\lambda,$$

which is the form in which this radiation law is most often written.

Stefan's law gives the relation between the total amount of radiation emitted by a black body and the temperature. It is

$$E = \sigma T^4,$$

where the Stefan-Boltzmann constant $\sigma = 5.672 \times 10^{-5}$ erg/cm.²/deg.⁴/sec. E is the amount of energy emitted per cm.² per second and T is the temperature.

Example.—What would be the amount of energy radiated/cm.²/sec. by the sun's surface if the temperature is 5700°K.?

$$\begin{aligned} E &= 5.672 \times 10^{-5} (5700)^4 = 5.99 \times 10^{10} \text{ ergs/cm.}^2/\text{sec.} \\ &= 5.99 \text{ kilowatts/cm.}^2 \end{aligned}$$

Wien's Law gives the wave-length at which the intensity of the radiated energy is a maximum. The relation is

$$\lambda_{\text{max.}} T = 0.28971 \text{ cm. deg.}$$

Example.- At what wave-length in the spectrum is the intensity a maximum for a star whose temperature is 5000° ?

$$\lambda_{\max.} = \frac{0.2897}{5000} \text{ cms.} = 5.794 \times 10^{-5} \text{ cms.} = 5794\text{A},$$

since $1\text{A} = 10^{-8} \text{ cms.}$

Hence the maximum intensity occurs in the yellow near 5800A .

APPENDIX D

LIST OF ASTRONOMICAL CONSTANTS

One astronomical unit	1.4964×10^{13} cms. (93,000,000 miles)
One light year	9.463×10^{17} cm.
One parsec = 3.26 light years	3.084×10^{18} cm.
Mass of the sun	1.991×10^{33} grams
Radius of the sun	6.963×10^{10} cm.
Mean density of sun	1.41 grams/cm. ³
Surface gravity of the sun	2.740×10^4 cm./sec. ²
Energy radiated by the sun	3.79×10^{33} ergs/sec.
Absolute bolometric magnitude of the sun	+4.62 (Kuiper)
Absolute photovisual magnitude of the sun	+4.73 (Kuiper)
Temperature T_e of the sun	5710° (Unsöld)
Mass of the earth	5.974×10^{27} grams
Mean radius of the earth	6.3712×10^8 cm.
Average density of the earth	5.517 gram/cm. ³
Surface gravity of the earth	980.665 cm./sec. ²
Number of seconds in one year	3.1558×10^7 seconds

APPENDIX E

STELLAR MAGNITUDES

1. THE KINDS OF MAGNITUDES

AS WE SAW IN CHAPTER I, THE MAGNITUDE OF A STAR depends upon whether we are using a photographic, visual, or photoelectric method to observe it. On a blue-sensitive plate a red star may appear as a faint object but it may yet be quite bright to the eye. A star such as χ Cygni may appear to the eye as an object of the tenth magnitude, yet a thermocouple, which measures the total amount of all energy that reaches it, may reveal this star to be emitting as much radiation as a normal star of the fifth magnitude. Therefore, in expressing the magnitude of a star we must specify the kind of magnitude: visual, photographic, red, etc.

Suppose we photograph a star field upon a panchromatic plate through a red filter. The blue and green and much of the yellow light will be cut out and only red light over the range of a few hundred angstrom units will affect the plate. Experiments have shown that although radiations covering a span of several hundred angstrom units may fall upon the plate, the magnitudes determined will be just the same to a fair degree of approximation, as though all the light were

concentrated at one mean wave-length—called the *effective wave-length*. Clearly, the effective wave-length will depend upon the plate and filter and instrument used. For the Harvard magnitude work, Mrs. Payne-Gaposchkin has found, for example:

<i>UV</i> , ultraviolet (with ultraviolet filter)	3694Å
<i>YY</i> , yellow (photovisual)	5480Å
<i>RR</i> , red (red sensitive plate, red filter)	6336Å

The yellow magnitude system, based on yellow-sensitive plates and a yellow filter, is very similar to the ordinary visual system of magnitudes wherein the brightnesses of stars are measured directly by the eye.

A description of the methods of measuring magnitudes by diaphragms, gratings, filters, etc. lies outside the scope of this discussion.*

2. RELATIONS BETWEEN THE ABSOLUTE MAGNITUDE, TEMPERATURE, AND RADIUS OF A STAR

In Chapters 4 and 5 we mentioned that if we knew the absolute brightness of a star and its size, we could find its temperature, or if we knew the temperature and true brightness of a star that we could find its size. The relation between the absolute magnitude of a star (as measured in a magnitude system of effective wave-length λ), its radius, and its temperature, is derived in Russell-Dugan-Stewart, "Astronomy," Vol. 2, p. 732. The formula is

$$M_{\lambda} = C_{\lambda} - 5 \log R + \frac{1.555}{\lambda T} + x$$

* Compare Bok and Bok, *The Milky Way*, Chapter 2, p. 21; also Campbell and Jacchia, *The Story of Variable Stars*, Chap. 2. See also, Baker and Dimitroff, *Telescopes and Accessories*.

where x is a correction factor which depends on λ and T , and may be important at high temperatures.

$\frac{1.555}{\lambda T}$	5.0	4.0	3.0	2.0	1.0
x	-0.01	-0.03	-0.07	-0.19	-0.55

For photovisual magnitudes let us adopt

$$\lambda = 5480\text{A} = 5.48 \times 10^{-5} \text{ cms.}$$

To evaluate C_λ we note that a black body of the same size and temperature as the sun would have approximately the absolute magnitude 4.73. Since R is measured in terms of the sun's radius, $R = 1.0$ and $\log R = 0.00$ for the sun. Hence, if the effective temperature of the sun is 5700° ,

$$4.73 = C_\lambda + 4.98 - 0.01, \quad \text{or,} \quad C_\lambda = -0.24.$$

The relation between absolute visual magnitude, radius, and effective temperature is

$$M_v = -0.24 - 5 \log R + \frac{28,400}{T}.$$

Example.—The absolute magnitude of Wolf 359 is 16.6. If its surface temperature is 2800° , what is its diameter in terms of that of the sun?

$$16.6 = -0.24 + 10.14 - 5 \log R, \quad \text{or} \quad \log R = -1.34,$$

whence

$$R = 0.046.$$

Example.—The radius of the brighter component of ζ Vulpeculae is 4.23 in terms of the sun. The spectral type

is *B3*. What is the absolute magnitude? The temperature of a *B3* star is 18,600°, according to Kuiper. Hence

$$M_v = -0.24 - 5 \times .627 + 1.53 = -1.84.$$

In this discussion we have assumed that stars radiate like black bodies. We know that this is only a first approximation, particularly rough for *A* stars, which show strong continuous absorption due to hydrogen, and for the cool stars whose spectra show strong molecular bands. Nevertheless, over short spectral ranges the black-body approximation may sometimes be a fairly good one.

3. COLOR INDICES AND BOLOMETRIC CORRECTIONS

We have seen that the various magnitude systems, red, yellow, or photovisual, blue or photographic, and ultraviolet differ from one another by utilizing light of different colors in measuring the brightness of a star. A red star may be bright in the system of red magnitudes, fairly bright as a yellow star but quite faint in the blue or ultraviolet systems. Conversely, the excessively hot nuclei of planetary nebulae are frequently fairly conspicuous in the ultraviolet, weak in the blue, and too faint to be observed in the yellow or red. The relations between the magnitude systems may be worked out from the formula on page 296 for stars that radiate like black bodies. In other words, if we know, say, the visual magnitude of a star and its temperature, we ought to be able to calculate what its violet or blue or red magnitude should be.

The difference between the photographic or visual magnitude of a star is called the *color index*. It is, therefore,

$$I = m_{ptg} - m_v,$$

and depends only on the temperature. For cool stars the color index is positive and may become very large; for hot

stars it becomes negative but never greater than a few tenths of a magnitude. The photographic and visual magnitude scales are so adjusted that for a sixth-magnitude A0 star they are the same and the color index is therefore zero.

The various kinds of magnitudes that we have been discussing, red, yellow, blue, etc., utilize radiation over a limited wave-length range. For many purposes we want to compare the luminosities of two stars with reference to the radiation for all wave-lengths taken together. We express the total luminosity of a star in terms of the so-called *bolometric magnitude*.

The difference between the bolometric and photovisual magnitude is called the bolometric correction:

$$B.C. = m_{bol} - m_{pv}.$$

The system of bolometric magnitudes is so adjusted that the bolometric corrections are small for stars like the sun. They become large for very hot stars where most of the energy is in the unobservable ultraviolet and also for very cool stars which radiate most of their energy in the infra-red. We tabulate the bolometric corrections that have

TABLE 14
THEORETICAL BOLOMETRIC CORRECTIONS IN MAGNITUDES FOR THE HOT
STARS
(After Kuiper)

Temperature °K.	B.C.	Temperature °K.	B.C.	Temperature °K.	B.C.
6,000	-0.06	10,000	-0.57	20,000	-2.18
6,500	0.00	11,000	-0.78	22,000	-2.40
7,000	-0.01	12,000	-0.98	25,000	-2.69
7,500	-0.12	14,000	-1.36	30,000	-3.12
8,000	-0.22	16,000	-1.66	40,000	-3.8
9,000	-0.40	18,000	-1.94	50,000	-4.3

been determined by Kuiper. For the hotter stars they may be computed from theory, taking into account the deviations from a black-body distribution produced by the hydrogen absorption at the series limit, etc. (Table 14). Most of the energy is in the ultraviolet and there are few absorption lines to disturb the continuous spectrum. For the cooler stars the radiometric observations of Pettit and Nicholson provide information about the bolometric correction. The empirical corrections are given in Table 15.

TABLE 15
EMPIRICAL BOLOMETRIC CORRECTIONS IN MAGNITUDES FOR THE COOLER STARS
(After Kuiper)

<i>Spec.</i>	<i>Main sequence</i>	<i>Giants M = 0.0</i>	<i>c-stars M = -4.0</i>	<i>Spec.</i>	<i>Main sequence</i>	<i>Giants M = 0.0</i>	<i>c-stars M = -4.0</i>
F2	-0.04	-0.04	-0.04	K4	-0.55	-1.11	-1.56
F5	.04	.08	0.12	K5	0.85	1.35	1.86
F8	.05	.17	0.28	K6	1.14		
G0	.06	.25	0.42	M0	1.43	1.55	2.2
G2	.07	.31	0.52	M1	1.70	1.72	2.6
G5	.10	.39	0.65	M2	2.03	1.95	3.0
G8	.10	.47	0.80:	M3	(2.35)	2.26	-3.6
K0	.11	.54	0.93:	M4	(2.7)	2.72	
K2	.15	.72	1.20	M5	-(3.1)	-3.4	
K3	-0.31	-0.89	-1.35				

Reproduced from *Astrophysical Journal*, vol. 88, p. 429, 1938.

Example.—The visual magnitude of Epsilon Eridani is 3.8. Its spectral type is K0 and it is a dwarf main-sequence star. What is its bolometric magnitude?

From Kuiper's table of empirical bolometric corrections we find, for a main-sequence K0 star,

$$\text{B.C.} = m_{bol} - m_{pv} = -0.11.$$

Hence

$$m_{bol} = 3.8 - 0.1 = 3.7,$$

where we have considered visual and photovisual magnitudes as equivalent.

5. THE RELATION BETWEEN APPARENT MAGNITUDE, ABSOLUTE MAGNITUDE AND DISTANCE

If we know the apparent brightness of a star and also its distance, we can find its absolute magnitude and therefore its intrinsic brightness compared with the sun. The absolute magnitude, it will be recalled, is the magnitude the star would have if placed at the standard distance of ten parsecs. The relation between absolute magnitude, apparent magnitude, and distance in parsecs is:

$$M = m + 5 - 5 \log r.$$

Example.—Gamma Geminorum, visual magnitude 1.93, has a parallax of $0''.040$ according to the Yale catalogue. What is its distance and absolute magnitude? Now

$$r \text{ (parsecs)} = \frac{1}{p} \text{ (seconds of arc);}$$

hence

$$r = \frac{1}{.040} = 25 \text{ parsecs;} \quad \log r = 1.40;$$

$$M = 1.93 + 5 - 5 \times 1.40 = 1.93 - 2.00 = -0.07.$$

The absolute photovisual magnitude of the sun is $+4.73$. Hence Gamma Geminorum is $(4.73) - (-0.07) = 4.80$ magnitudes brighter than the sun.

To change from magnitude differences to ratios of brightness we make use of the expression;

$$0.4(M_{\odot} - M_s) = \log \frac{L_s}{L_{\odot}},$$

where M_{\odot} is the absolute magnitude of the sun,

L_{\odot} is the brightness of the sun,

M_s is the absolute magnitude of the star,

L_s is the brightness of the star.

Hence to compare Gamma Geminorum and the sun;

$$0.4[4.73 - (-0.07)] = \log \frac{L_s}{L_\odot}, \quad \text{or}$$

$$0.4 \times 4.80 = 1.92 = \log \frac{L_s}{L_\odot}$$

whence $L_s/L_\odot = 83$. Thus Gamma Geminorum is 83 times as bright as the sun. For the derivation of the formulae relating magnitude and distance, see Bok and Bok, "The Milky Way," p. 33.

If there is absorption of light in space by obscuring matter (see Bok and Bok Chap. 8) the equation relating apparent and absolute magnitude must be modified. If the light of a distant star is dimmed P magnitudes by absorbing dust and gas in space, then (see Bok and Bok p. 138)

$$M = m + 5 - 5 \log r - P.$$

The absorption P produced by a given amount of cosmic dust depends on the color of light in which we make our observations. The dimming is less in red than in blue light.

Absolute magnitudes, like apparent magnitudes, may be visual or photovisual, photographic (blue), red, ultraviolet, or bolometric. The total luminosity of a star is given by its bolometric absolute magnitude.

APPENDIX F

LIST OF PLANETARY NEBULAE FOR SMALL TELESCOPES

WE REPRODUCE HERE A LIST, PREPARED BY MR. IELAND S. Copeland of Santa Barbara, California, of planetary nebulae suitable for observations with small telescopes. Successive columns give the New General Catalogue (NGC) number of the object, its position for 1945, the constellation in which it appears, and approximate angular dimensions. A double asterisk beside the NGC number signifies an easily observed object, a single asterisk one of medium difficulty, while entries without asterisks are more difficult to observe.

NGC	Right ascension	Declination	Constellation	Dimensions	Remarks
	<i>h m</i>	<i>° ′</i>			
650-1	1 39	+51 18	Per	87"×42"	Faint, cork-shaped.
1535	4 12	-12 53	Eri	20"×17"	Small, round.
1952**	5 31	+21 59	Tau	4'×6'	Crab nebula; not a true planetary; but resembles one; believed to have been formed by expansion of supernova of 1054 A.D. (See THE TELESCOPE, Sept.-Oct., 1939.)
2022	5 39	+ 9 04	Ori	22"×17"	Small, faint oval.
2392	7 26	+21 02	Gem	20"×13"	Small oval.
2438	7 39	-14 35	Pup	68"	Near north edge of open cluster NGC 2437.
2440	7 40	-18 04	Pup	54"×20"	Small, bright; no central star.
3242**	10 22	-18 22	Hyd	40"×35"	Bright.
3587**	11 12	+55 19	UMa	3'.3	One of largest and faintest of planetaries.
6210	16 42	+23 54	Her	20"×13"	Small oval.
6543	18 00	+66 38	Dra	22"×16"	Small, bright oval.
6572	18 09	+ 6 50	Oph	16"×13"	Small, fuzzy oval.
6720**	18 52	+32 57	Lyr	83"×59"	Ring nebula.
6818	19 40	-14 18	Sgr	22"×15"	Small, slightly oval.
6826*	19 43	+50 23	Cyg	27"×24"	Small globe.
6853**	19 57	+22 34	Vul	8'×4'	Dumbbell nebula; one of largest of planetary class.
7009*	21 01	-11 35	Aqr	25"×12"	Saturn nebula.
7293*	22 26	--21 07	Aqr	15'×12'	Largest planetary known; faint, helical.
7662*	23 23	+42 14	And	32"×28"	

APPENDIX G

THE IONIZATION AND EXCITATION FORMULAS

As we saw in Chapter 4, the theory of ionization explains the great changes exhibited by the spectra of the stars as we proceed along the spectral sequence from a hot *O* star to a cool *M* dwarf or giant. In the hotter stars the metals are ionized and no longer absorb radiation in the spectral ranges where we can observe them; the spectra of cooler stars are jammed full of metallic lines. In this section we shall devote some attention to both the excitation and ionization formulae.

1. THE MEANING OF THERMAL EQUILIBRIUM

Returning to the discussion of Chapter 4, let us fix our attention upon the excitations and ionizations of a group of atoms in our hypothetical box whose walls are maintained at some temperature T . If the temperature is sufficiently high, say four or five thousand degrees, atoms will dash wildly about, absorb and emit energy, collide with one another, and lose and regain electrons.

In Figure 148 let A be the ground level, and B, C, D, \dots excited levels. A fast electron may hit an atom in level A , lift it to level B , and then go away with less energy.

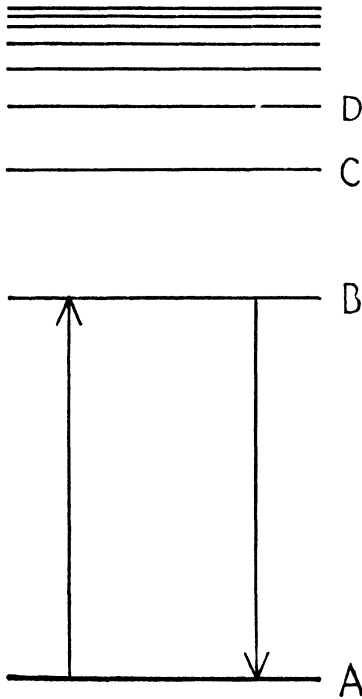

Fig. 148.—Schematic energy level diagram.

Similarly, other electrons may hit atoms which are in level B , de-excite them to the ground level A , and bounce off with increased energy. In an enclosure, these two processes will exactly balance. Likewise, the collisional excitations of level C will exactly equal the collisional de-excitations. A similar situation obtains for the emission and absorption of radiant energy:

Number of absorptions $A \rightarrow B$
 = number of emissions $B \rightarrow A$;
 Number of absorptions $A \rightarrow C$
 = number of emissions $C \rightarrow A$.

The number of ionizations from the level B will exactly equal the number of recaptures by the ion of electrons upon level B , etc. Thus every process is exactly balanced by its inverse process. Under such conditions, the assemblage of atoms is said to be in *thermodynamic equilibrium*.

2. THE EXCITATION EQUATION

Under conditions of thermodynamic equilibrium, the relative numbers of atoms in two levels A and B is given by the Boltzmann equation:

$$\frac{N_B}{N_A} = \frac{g_B}{g_A} e^{-\frac{\chi_{AB}}{kT}},$$

where k is Boltzmann's constant, 1.380×10^{-16} , e is the base of natural logarithms, 2.718, T is the absolute temperature, and χ_{AB} is the energy necessary to excite the atom from level A to level B , in electron volts; g_B and g_A are constants depending on the levels involved and may easily be computed from atomic theory. If ν_{AB} is the frequency of the line emitted in the transition from B to A , then

$$\chi_{AB} = h\nu_{AB}.$$

Generally, it is more convenient for numerical computations to have this formula in another form. If we take logarithms to the base 10 and express χ_{AB} in electron volts, then

$$\log \frac{N_B}{N_A} = -\frac{5040}{T} \chi_{AB} + \log \frac{g_B}{g_A}.$$

In many cases g_A and g_B are small numbers of about the same size and for a qualitative notion of the ratio N_B/N_A we may omit them and write simply:

$$\log \frac{N_B}{N_A} \sim -\frac{5040}{T} \chi$$

Example.—If A is the ground level of the *OIII* ion, (in this case, A is actually a group of three levels close together but we may treat them as one level for the present problem—see Chapter 9, Figure 97), and the excitation potential of level B is 2.48 volts, $g_A = 9$, $g_B = 5$, what will be the relative numbers of atoms in the level B in thermodynamic equilibrium with a temperature of 10,000°?

$$\log \frac{N_B}{N_A} = -1.25 - 0.25 = -1.50, \quad \text{or}$$

$$N_B = 0.032N_A.$$

Example.—What would be the fraction of hydrogen atoms excited to the second energy level in the sun, if the excitation temperature is 5700°?

$$\begin{aligned} \chi_{AB} &= 10.16 \text{ volts,} & g_B &= 4, & g_A &= 1. \\ \log \frac{N_B}{N_A} &= -\frac{5040 \times 10.16}{5700} + \log 4 = -8.98 + 0.60 \\ &= -8.38, & \text{or} & & N_B &= 4.2 \times 10^{-9} N_A, \end{aligned}$$

i.e., under these conditions, about four atoms in every thousand million are excited to the second level and thus capable of absorbing the Balmer lines.

3. THE IONIZATION EQUATION

Under conditions of thermodynamic equilibrium, the relative numbers of ionized and neutral atoms are given by the Saha equation:

$$\log \frac{N_1}{N_0} P_e = -\frac{5040}{T} I + 2.5 \log T - 6.48 + \log \frac{2B_1(T)}{B_0(T)},$$

where N_1 = number of ionized atoms,

N_0 = number of neutral atoms,

P_e = electron pressure in atmospheres,

I = ionization potential in volts (see Table 3),

T = temperature,

The correction term $\log \frac{2B_1(T)}{B_0(T)}$ is a function of the temperature for any given atom. It depends on the number and kind of energy states and may be computed from atomic theory. For many practical purposes it is legitimate to replace this term by $\log \frac{2b_1}{b_0}$ where b_1 and b_0 are atomic constants depending on the kind of ground energy levels in each ion. In Table 16 we give the correction term $\log \frac{2b_1}{b_0}$, or in some cases $2B_1(T)/B_0(T)$, for the atoms whose ionization poten-

tials are tabulated in Table 3. The first column gives the constant for the calculation of first ionizations, the second column for the calculation of second ionizations, etc.

Example.—What are the relative proportions of neutral and ionized magnesium in the sun, if $T = 5700^\circ$,

$$\log P_e = -4.70$$

(see Figure 149)? From Table 3, we find that the ionization potential of neutral magnesium is 7.61 volts.

$$\frac{5040}{T} I = 6.73, \quad 2.5 \log T = 9.39.$$

From Table 16

$$\log \frac{2b_1}{b_0} = 0.60.$$

Hence

$$\log \frac{N_1}{N_0} = 1.48, \quad \text{or} \quad \frac{N_1}{N_0} = 30,$$

i.e., there is thirty times as much ionized as neutral magnesium in the sun; 97% of the magnesium is ionized, 3% is neutral.

Example.—What is the relative amount of TiII in the atmosphere of Sirius, whose temperature is $10,000^\circ$, and for which the electron pressure is 2.0×10^{-4} atmospheres? The ionization potential of TiI is 6.81 volts.

$$\frac{5040}{T} I = 3.43; \quad 2.5 \log T = 10.00; \quad \log P_e = -3.70.$$

From Table 16,

$$\log \frac{2b_1}{b_0} = 0.43;$$

hence

$$\log \frac{N_1}{N_0} = 4.22, \quad \text{or} \quad \frac{N_1}{N_0} = 17,000,$$

i.e., titanium is almost completely ionized. Therefore we suspect $TiIII$ might be ionized so we shall apply the ionization equation again. The ionization potential of $TiIII$ is 13.6 volts;

$$\frac{5040}{T} I = 6.85, \quad \log \frac{2b_1}{b_0} = 0.01,$$

whence

$$\log \frac{N_2}{N_1} = 0.38,$$

and the ratio of $TiIII$ to $TiII$ is 2.4, or about 71% of the titanium atoms are doubly ionized and about 29% are singly ionized.

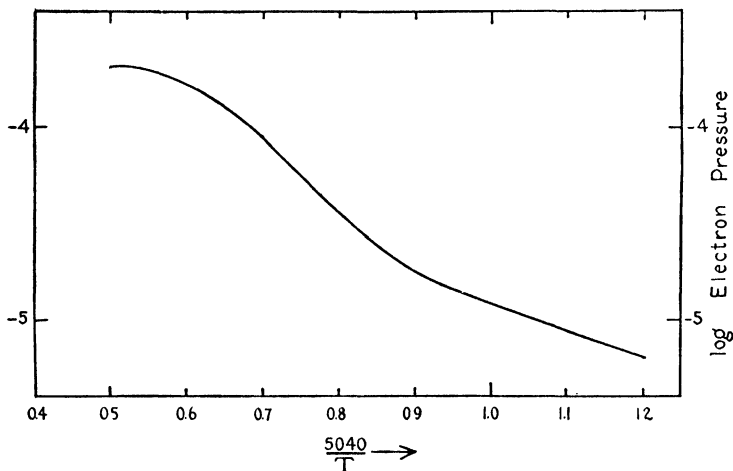

Fig. 149.—The variation of the mean electron pressure with temperature for stars of the main sequence.

In the application of the ionization formula we must know the electron pressure as well as the temperature. For most types of calculation it is sufficient to use a mean value of the electron pressure for the stellar atmosphere.

The work of Russell suggests an electron pressure in the sun of about 2×10^{-5} atmospheres, while the broadening of the hydrogen lines in the *A*-type dwarfs yields an electron pressure of about 2×10^{-4} atmospheres in these stars. In Figure 149, $\log P$ is plotted against $5040/T$ for stars of the main sequence.*

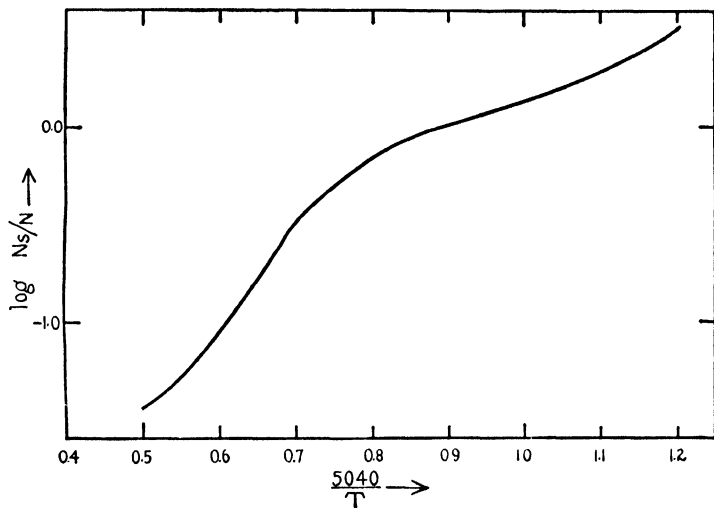

Fig. 150.—The relative numbers of atoms above the photosphere for stars of the main sequence.

Finally, to compare the numbers of say, neutral iron atoms above the photosphere of the sun with those above the photosphere of some other dwarf, we must have some knowledge of the relative transparencies of the two atmospheres, i.e., the opacity variation. Figure 150, based on the electron pressures of Figure 149 and the opacity calculations of Wildt and Strömberg, shows how the “depth of the photo-

* There is some indication these theoretical values may be a bit high for stars like the sun.

sphere" varies along the main sequence. If N_s is the number of atoms above the photosphere of a star of temperature T , and N_\odot is the number above the photosphere of the sun, the curve shows how the ratio N_s/N_\odot varies with T . For example, there are twice as many atoms above the photosphere of a star of effective temperature 4500° as above the photo-

TABLE 16
LOG $\frac{2b_{r+1}}{b_r}$ FOR DIFFERENT IONS*

Atom	Atomic No.	$r = 0$	1	2	3
Hydrogen, H.	1	0.00			
Helium, He.	2	0.60	0.00		
Carbon, C.	6	0.13	-0.48	0.60	0.00
Nitrogen, N.	7	0.65	0.13	-0.48	0.60
Oxygen, O.	8	-0.05	0.65	0.13	-0.48
Neon, Ne.	10	1.08	0.48	-0.05	0.65
Sodium, Na.	11	0.00	1.08	0.48	-0.05
Magnesium, Mg.	12	0.60	0.00	1.08	0.48
Aluminum, Al.	13	-0.48	0.60	0.00	1.08
Silicon, Si.	14	0.09	-0.48	0.60	0.00
Sulphur, S.	16	-0.05	0.65	0.13	-0.48
Argon, A.	18	1.08	0.48	-0.05	0.65
Potassium, K.	19	0.00	1.08	0.48	-0.05
Calcium, Ca.	20	0.60	0.00	1.08	0.48
Titanium, Ti.	22	0.43	0.01	-0.02	
Vanadium, V.	23	0.21	0.14	0.18	-0.02
Chromium, Cr.	24	0.18	0.92	0.35	0.18
Manganese, Mn.	25	0.37	0.23	0.92	0.35
Iron, Fe.	26	0.57			
Cobalt, Co.	27	0.18			
Nickel, Ni.	28	-0.30			
Strontium, Sr.	38	0.46	-0.03		

* For Si, Ti, V, Cr, Fe, Ni and Sr we have tabulated $2B_{r+1}(T)/B_r(T)$ as calculated for the temperature of the sun, 5700° instead of $2b_{r+1}/b_r$, since for these atoms the approximation is not sufficiently accurate.

sphere of the sun, half as many above the photosphere of a star of temperature 6700° as above the photosphere of the sun. We may now predict the relative numbers of atoms above the photosphere for stars of the main sequence, with the aid of these diagrams, the Kuiper temperature scale, and the ionization formula.

The discussions by Massey and Bates, Wildt, Williamson, Chandrasekhar and Mrs. Krogdahl, and most recently by L. Henrich make it very reasonable to suppose that the negative hydrogen ion contributes the bulk of the opacity in stars like the sun. It is very difficult to calculate the wavelength variation of the opacity and even Henrich's detailed calculations do not give it as nearly constant as seems to be required by the observational data.

Chandrasekhar and Wildt have discussed the possibility that the negative oxygen ion may play a role in the cooler stars. The metals probably contribute only a small share of the haziness of the solar atmosphere. In the hottest stars one might expect the noble gases such as helium and neon to make important contributions to the opacity but Greenstein has shown that in most cases their effects may be entirely neglected.

The authors wish to record their thanks and appreciation for the splendid cooperation shown them by the Directors and staff members of the many observatories, especially Mount Wilson and Lick, who have supplied them with a large number of the illustrations used in this book. They are particularly grateful to the late DR. A. B. WYSE, of LICK OBSERVATORY, for his illustrations of nebular spectra photographed with the image-slicer, and to MR. EDISON HOGE, of MOUNT WILSON, and MR. FRED CHAPPELL, of LICK, for a number of excellent enlargements.

INDEX

References to figures are given by the number of the figure in italics

A

- Absolute magnitudes, spectroscopic, 88–91
- Adams, W. S.*, 12, 43, 86, 206, 207, 208, 213
- Aitken, R. G.*, 12
- Allegheny Observatory, 29
- Allen, C. W.*, 58
- Alpha Centauri, 7
- Alpha particle, defined, 266
- Anderson, C. D.*, 268
- Angstrom, A. J.*, 22
- Angstrom unit, defined, 22
- Astronomical unit, defined, 7
- Atom, energy levels of OII, 98
 - of OIII, 97
 - of schematic, 53, 148
 - hydrogen, Bohr's model of, 47, 27
 - ionization potential, 70–71
 - defined, 49
 - ionized, 59–60
 - defined, 49
 - mass of, 43
 - nucleus of, 42
 - wave model of, 57, 31
- Atomic number, 43–45
 - defined, 43
- Atoms, and radiation, 40–47
 - complex, 53–57

- Atoms, effects of pressure on, 69–71, 89
 - temperature on, 68–72
 - number of absorbing, 102, 150
 - structure of, 41–45, 54–57

B

- B* emission stars, 239–254
 - profiles of spectral lines in, 240–241, 130, 132
- Baade, W. A.*, 82, 167, 172
- Bailey, S. I.*, 153
- Baker, J. G.*, 296
- Baldwin, R. B.*, 242, 243
- Balmer, J. J.*, 46
- Balmer series, 24, 13, 51, 101, 116
 - absorption at limit of, 60, 116
 - defined, 46–47
 - in long-period variables, 147
 - in planetary nebulae, 181, 185, 190, 191
 - in solar chromosphere, 26
- Barbier, D.*, 66
- Barnard, E. E.*, 152
- Beals, C. S.*, 212, 117, 225, 119, 226, 231, 233, 126*b*, 127, 236, 238, 129
- Belopolsky, A.*, 12
- Berman, L.*, 11, 103, 126
- Beta Lyrae, 15, 243–247

- Beta Lyrae, as eclipsing binary, 243–244, 135
 interpretation of, 246–247, 136
 spectrum of, 243–244, 134
- Bethe, H. A., 141, 142, 263, 265, 272, 273, 274, 275, 277, 280
- Birge, R. T., 290
- Blanch, G., 141, 142, 263
- Bohr, N., 47, 50, 59
- Bok, B. J., 134, 197, 280, 296, 302
- Bok, P. F., 134, 197, 280, 296, 302
- Boltzmann's constant, 261, 292, 307
- Bowen, I. S., 177, 92, 180, 181, 94, 184, 102, 254
- Boyce, J. C., 71
- Brackett series, 46, 51
- Bradley, J., 11
- Brahe, T., 169
- Broadening of spectral lines, 91–99
 collisional, 98, 109
 Doppler, 92, 50a, 50b, 104, 55b, 107
 natural, 91, 49, 103, 54a, 55a, 105
 Stark Effect, 95, 51a, 109
 turbulence, 99, 109
 Zeeman Effect, 95, 51b, 109
- Bunsen, R. W., 23
- Burns, K., 29
- C
- California Institute of Technology, 180, 268
- Campbell, L., 15, 121, 128, 70, 196, 296
- Campbell, W. W., 196
- Cannon, A. J., 32, 22, 231
- Carbon cycle, *see* elements, transmutation of
- Chandrasekhar, S., 279
- Chromosphere, 47, 26
- Color, meaning of, 21–23
 of light waves, 11, 22
- Composition, chemical, of stars and nebulae, *see* elements, abundance of
- Condon, E. U., 8
- Copeland, L. S., 303
- Cornell University, 272
- Cosmic rays, 269
- Crab Nebula, 169–172, 87
 expansion of, 172
 spectrum of, 88, 172
- Critchfield, C. L., 274
- Curtis, H. D., 12, 89
- Curtiss, R. H., 126, 138, 242
- Curve of growth, 103–112
 combined natural and Doppler broadening, 108, 57
 Doppler broadening, 55b, 107
 Gamma Geminorum, 59
 natural broadening, 55a, 107
 sun, 58
- Cyanogen, spectrum of, 61, 33
- Cyclotron, 266, 143
- D
- Danjon, A., 66a
- Davidson, C. R., 66
- Dearborn Observatory, 242
- Deuterium, 267
- Diffuse nebulae, 214–220, 112, 113
 emission, 215–217
 in Messier 33, spectra of, 114
 reflection, 214–215, 217–220, 111
 mechanism of light scattering by, 217–220, 115
 temperature of stars associated with, 214, 215
- Dimittroff, G. Z., 296
- Dirac, P. A. M., 268
- Dissociation Formula, 124–125 *see also* Appendix G
- Dominion Astrophysical Observatory, 39, 208, 212, 225, 231
- Donaldson, P. H., 143

Doppler, C., 36
 Doppler effect, 36-37, 92-94
 Double stars, 11
Duncan, J. C., 171, 104
Dunham, T. H., 206, 207

E

Eddington, A. S., 7, 133, 137, 69, 138, 139, 273
Einstein, A., 257
 Electron, 41-42
 defined, 41
 positive, *see* positron
 spinning, magnetic effects of, 30
 Electron shells, 55
 Electrostatic generator, 266
 Electrostatic units, defined, 290
 Elements, abundance of, 111-112
 in diffuse nebulae, 221
 in gaseous nebulae, 177, 221
 in interstellar space, 209, 213
 in solar atmosphere, 114
 in Tau Scorpii, 115
 periodic table of, 44
 transmutation of, 265-274
 beryllium-proton, 269
 boron-proton, 269, 271
 carbon cycle, 272, 273, 277
 deuterium-proton, 267
 iron-neutron, 267
 lithium-proton, 269, 271, 274
 nitrogen-neutron, 267
 proton-proton, 268, 274
Elvey, C. T., 99, 204, 211, 217
 Energy curves for a perfect radiator, 34, 99
 Equivalent width of absorption line, defined, 102
 External galaxies, bright lines in, 216

F

Fath, E. A., 138
Fleming, W. P., 32

Forbidden lines, in planetary nebulae, 181-187
 as thermostats, 192-194
 identification of, 181-185, 96
 in supernovae, 168
Fraunhofer, J., 15, 27, 55
 Frequency of light waves, defined, 22

G

Galactic nebulae, *see* diffuse nebulae
 Galaxy, defined, 3
 Gamma Cassiopeiae, 242-243
 spectrum of, 133
Gamow, G., 265, 271, 146
Gaposchkin, C. H. P., 38, 77, 133, 141, 166, 168, 271, 296
Gaposchkin, S., 133, 125, 232, 233
Genard, J., 99
 Globular cluster, 65
Goedicke, V., 80
 Gravitation, law of, 10
Greaves, W. M. H., 66
Greenstein, J. L., 202, 204
 Greenwich Observatory, 66

H

Hartmann, J., 206
 Harvard Observatory, 18, 20, 32, 47, 65, 81, 90, 91, 112, 113, 232, 139
 Harvard Physics Laboratory, 33, 143, 144, 145
Heger, M. L., 206
Helmholtz, H. L. F., 257
Henroteau, F., 66b
 Henry Draper catalogue, 7, 33, 224
Heney, L. G., 202, 204, 218, 219
Herschel, W., 11, 174
Hertzsprung, E., 12, 41
Hoffleit, D., 47, 85
Holmberg, E., 18
Hopmann, J., 80
 Horsehead Nebula, 104

- Hoyle, F.*, 275
Hubble, E. P., 165, 166, 214
Huggins, W., 28, 35
Humason, M. L., 164
 Hydrogen, Bohr's model of atom,
 47-53, 27
 energy-level diagram of, 28
 spectrum of, 24, 13
Hynek, J. A., 134, 137, 138, 250
- I
- Index Catalogue (Dreyer), 174
Innes, R. T. A., 11
 Interstellar space, atoms and molecules in, 205-214
 discovery of, 206-208,
 107
 spectrum of, 106, 108,
 109, 206-214
 composition of, 209, 213
 dust and gas in, 197-221
 interaction between,
 220-221
 mass of, 199
 nature of particles in, 203-205
 physical conditions in, 210-214
 sizes of particles in, 201-203
 Iron, spectrum of, 29
 Isotopes, defined, 45
 in cool stars, 146
- J
- Jacchia, L.*, 15, 121, 128, 196, 296
Jacobsen, T. S., 66b
Joy, A. H., 12, 71, 151
- K
- Kepler, J.*, 170
Kienle, H., 66
King, R. B., 127
Kirchhoff, G. R., 23, 27, 291
 Kirchhoff's laws, 23-27, 14, 192
 defined, 25
- Kohlschütter, A.*, 86, 44
Kopal, Z., 80, 244, 246, 135
Kron, G. E., 223
Kuiper, G. P., 9, 35, 67, 81, 237, 246,
 278, 294, 298, 299, 300, 313
- L
- Lick Observatory, 18, 13, 24, 25, 39,
 26, 60, 76a, 76b, 76c, 76d, 79,
 87, 88, 172, 89, 177, 91, 94,
 95, 196, 206, 111, 216, 114,
 116, 224, 225, 123
 Light year, defined, 7
Lowan, A. N., 141, 142, 263
Luyten, W. J., 12, 278
Lyman, T., 46
 Lyman series, 51
 in planetary nebulae, 190, 191
Lytleton, R. A., 275
- M
- Magnitudes, absolute, defined, 9
 bolometric, defined, 9
 photoelectric, 9
 photographic, defined, 9
 scale, 8
 stellar, Appendix E
Marshak, R. E., 141, 142, 263, 279
Martin, E. G., 66
 Mass-luminosity law, 16-18, 7, 258
Maury, A. C., 32
Mayall, N. U., 87, 88, 172
 McDonald Observatory, 59, 115,
 211, 218
McKellar, A., 208
McLaughlin, D. B., 80, 162, 83, 165,
 242
 McMath-Hulbert Observatory, 128,
 64, 105
Menzel, D. H., 16, 26, 113, 120, 191,
 225, 118
Merrill, P. W., 74, 149, 106, 231
 Messier's Catalogue, 174

- Metastable levels, 185, 251
Michelson, A. A., 85
 Michigan Observatory, 66, 138, 162, 83, 242
 Milky Way, schematic outline, 2
Milne, E. A., 279
Minkowski, R., 167, 168, 86, 172
Minnaert, M., 99
 Mira Ceti, companion of, 151, 236–237
 light curve of, 70, 140
 spectrum of, 143, 73*a*, 73*b*
 Molecules, abundance of in stars, 124–127
 effects of pressure on, 125
 temperature on, 123–125
 schematic model of, 60, 32
 spectra of, 60
Moore, C. E., 112
Moore, J. H., 39, 80, 196
Morgan, W. W., 23, 45, 46, 48, 52, 147
 Mount Wilson Observatory, 8, 19, 39, 88, 120, 62, 63, 127, 141, 72, 143, 73*a*, 73*b*, 149, 75, 81, 82, 164, 165, 84, 86, 104, 108, 206, 208, 109, 212, 213, 214, 124, 231, 133
- N
- Nebula, Orion, 28, 18
 Nebulae, diffuse, *see* diffuse nebulae
 planetary, *see* planetary nebulae
 Neutron, 265–269
 defined, 41
 New General Catalogue (Dreyer), 174
Newton, I., 19, 10, 8, 23
 Newton's law of gravitation, 10
Nicholson, S. B., 141, 149, 300
 Nova Aquilae, development of shell about, 87, 161
 Cygni (1920), light curve of, 77
 spectrum of, 76*a*, *b*, *c*, *d*
 Nova Herculis (1934), profile of MgII line in, 79
 Lacertae (1936), variation of line intensities in, 80
 Persei (1901), development of shell about, 161, 82
 Novae, 152–165
 expanding shells about, 161, 87, 82
 schematic diagram of, 78
 Nuclear reactions, *see* elements, transmutation of
- O
- Oort, J. H.*, 201
 Orion Nebula, 28, 18
 spectrum of, 79
- P
- P* Cygni stars, 233–239
 dimensions of, 237
 distances of, 237
 luminosities of, 237
 profiles of spectral lines in, 127, 233
 relation to novae, 238, 129
 spectra of, 233–236, 126*a*, 126*b*
 spectral classes of, 237
 structure of, 128
 temperatures of, 237
 Parallaxic shift, 6, 4
 Parallax, defined, 6
Paraskevopoulos, J. S., 18, 112
 Paris Observatory, 224
 Parsec, defined, 7
 Paschen series, 46, 51, 116
Pease, F. G., 82, 85
 Period-luminosity law, 134, 67
 Perkins Observatory, 120*a*, 134, 244, 137
Petrie, W., 139

- Pettit, E.*, 141, 149, 300
- Phi Persei, 247-251
 spectrum of, 249-250, 137, 139
 velocity variation of, 138
- Photosphere, 28
- Pickering, E. C.*, 32, 21, 39, 59
- Planck, M.*, 50
- Planck's constant, 292
 law, 50, 291-292
- Planetary nebulae, Balmer series in, 181, 185, 190, 191
 composition of, 177-179
 densities of, 177
 dimensions of, 177
 distances of, 177
 distribution of brightness in, 103
 drawings of, 89
 "eight-burst" planetary, 90
 fluorescence in, 187-191
 forbidden lines in, 181-187
 as thermostats, 192-194
 identification of, 181-185, 96
- Lyman series in, 190-191
 methods of observing, 179-181
 origin of, 196
 of hydrogen emission lines in, 189-191, 100
 permitted lines of OIII in, 194-196, 102
 physical nature of, 174-179
 slit spectra of, 94
 slitless spectra of, 91
 temperatures of, 177
 Wolf-Rayet stars in, 191
- Plaskett, H. H.*, 59
- Popper, D. M.*, 161, 80
- Positron, 269, 272, 144, 274
- Pound, J.*, 11
- Princeton Observatory, 112, 118
- Proton, 41-42
- R
- Radiation laws, 291-293
- Rayet, G.*, 224
- Refraction, 20, 9
- Renyl, D.*, 18
- Reversing layer, 27, 17
- Ritchey, G. W.*, 165
- Ritter, A.*, 137
- Roach, F. E.*, 63, 204, 217
- Rosenfeld, L.*, 207
- Rosse, Lord*, 170
- Rufus, W. C.*, 138
- Russell, H. N.*, 12, 40, 112, 124, 125, 126, 277, 311
- Russell-Hertzsprung diagram, 78, 39
- S
- Saha, M. N.*, 70, 112, 308
- Sanford, R. N.*, 213, 231
- Schalén, C.*, 202, 220
- Schaub, W.*, 80
- Scheiner, J.*, 222
- Schwarzschild, M.*, 66a, 133, 138, 139, 148
- Scott, R. M.*, 148
- Scott, W.*, 173
- Secchi, Father*, 30, 32
- Seeliger, H.*, 218, 219
- Shapley, H.*, 67, 68, 135, 137, 280
- Shortley, G. H.*, 8
- Sirius, 7, 118
- Sodium, spectrum of, 25, 11
- Spectra, classification of, 30
 of super-giant and dwarf, compared, 45, 46
- Spectral lines, widths of, 91-99
 collisional broadening, 98, 109
 Doppler broadening, 92, 50a, 50b, 104, 54b, 55b, 107
 electric fields, 94, 51a
 magnetic fields, 94, 51b

- Spectral lines, widths of, natural broadening, 91, 49, 103, 54a, 55a, 105
turbulence broadening, 99, 109
sequence, 23
 branching of, 125
 meaning of, 72
- Spectroscope, 19, 10
- Spectroscopic absolute magnitudes, 88-91
- Spectroscopic binary, 39, 25
- Spectrum, objective prism, photograph of, 20
 of atoms and molecules in interstellar space, 106, 108, 109, 206-214
 of Beta Lyrae, 243-244, 131
 of Crab Nebula, 172, 88
 of cyanogen, 61, 33
 of diffuse nebulae in Messier 33, 114
 of Gamma Cassiopeiae, 133
 of hydrogen, 24, 13
 of I. C. 4182, 86
 of iron, 29
 of long-period variables, 72
 of Mira Ceti, 143, 73a, 73b
 of Nova Cygni (1920), 76a, b, c, d
 of Orion Nebula, 19
 of *P* Cygni stars, 233-236, 126a, 126b
 of Phi Persei, 249-250, 137, 139
 of planetary nebulae, slit, 94
 slitless, 91, 95, 101
 of sodium, 25, 14
 of solar eclipse, 26
 of spectroscopic binary, 25, 39
 of white dwarf star, 147
 of Wolf-Rayet stars, 116, 224-225
 of Zeta Aurigae, 62
 radiation, 23, 12
 solar, Fraunhofer map of, 15
 Utrecht map of, 56
- Spitzer, L.*, 220, 221
- Stark effect, 95, 51a, 109
- Stars, *B* emission, *see B* emission stars
 composition of, 112
 density of, 15, 81
 double, 11
 dwarf, 67, 79
 eclipsing, 13, 5, 6
 energy sources in, 256-258
 evolution of, 270-274
 giant, 17, 67, 79
 dimensions of, 42c
 energy generation in, 274-277
 interiors of, 259-265
 density variation in, 141
 temperature variation in, 142
 luminosity of, 81, Appendix E
 main-sequence, central temperatures of, 264-273
 dimensions of, 83, 42a
 energy generation in, 272-274
 variation of electron pressure with temperature for, 149
 masses of, 80, 81
 P Cygni, *see P* Cygni stars
 radial velocities of, 36-39, 24
 rotating, profile of spectral line in, 132
 schematic diagram of, 131
 sizes of, 13-18, 81-85, 86, Appendix E
 sub-dwarf, 237
 super-giants, 17, 79
 dimensions of, 83, 42b
 surface gravity, 81
 temperatures of, 62-77, Appendix E
 variable, 128-151
 Cepheid, characteristics of, 133
 light variation of, 60a
 period-luminosity relation, 133, 67
 pulsation theory of, 135

- Stars, variable, Cepheid, spectral variation of, 133
 velocity variation of, 66*b*
 long-period, 139-151
 light curve of, 70
 spectra of, 72, 143
 spectral energy curves of, 71
 variation of, 141
 veil theory of, 149
 white dwarfs, 18, 79, 84
 spectrum of, 147
 structure of, 278-280
 Wolf-Rayet, *see* Wolf-Rayet stars
- Stebbins, J.*, 66*a*
- Stefan's law, 63, 291, 292
- Stellar atmosphere, cross section of, 118
 dimensions of extended, 251-254
 opacity of, 115
 brightness, 8-9
 distances, 5-8
- Sterne, T. E.*, 138
- Steward Observatory, 63
- Strand, K. A.*, 18
- Strömgren, B.*, 212, 263, 273, 275, 311
- Struve, O.*, 99, 127, 204, 211, 110, 213, 217, 241, 132, 246, 136, 251, 253, 254
- Sun, central temperature of, 263
 composition of, 114
 eclipse spectrum of, 26
 prominences on, 61, 105
 spectrum of, 15, 16
- Supernovae, 165-172
 forbidden lines in, 168
 in NGC 3184, 84
 light curve of I. C. 4182, 85
 luminosities of, 167
 spectrum of I. C. 4182, 86
 synthetic spectra of, 168
 temperatures of, 166
- Swings, P.*, 127, 207, 254
- T
- Telescope, The*, 39
Teller, E., 265
 Temperature, variation of line intensity in, 37, 73
 Thermocouple, 141
 Thermodynamic equilibrium, defined, 305-306
- U
- Unsöld, A.*, 115, 294
 Utrecht Solar Atlas, 56
- V
- van den Bos, W. H.*, 11
van Gent, H., 12
van Maanen, A., 84
von Weizsäcker, C., 265
- W
- Wave-length, effective, defined, 296
 of light waves, defined, 21
- Weighing the stars, 9
- Whipple, F. L.*, 166, 168, 169, 196
White, H. E., 31, 51*b*
- Wien's law, 291, 292-293
- Wildt, R.*, 118, 311
Williams, R. C., 66
Wilson, O. C., 120, 121, 231, 232, 233
Wilson, R. E., 141, 231
Wolf, M., 224
- Wolf-Rayet stars, 115, 183, 191, 224-233
 as nuclei of planetary nebulae, 230, 123
 dimensions of, 233
 distances of, 231
 evolution of, 277
 in eclipsing binaries, 232-233, 125

- Wolf-Rayet stars, luminosities of,
231
mass of, 233
model of, 225–227, 120
profiles of spectral lines in,
225–226, 119
relation to novae, 238, 129
spectra of, 116, 224–225
spectral classification of, 229–
230
temperatures of, 226–229
- Wollaston, W. H.*, 27
Wright, W. H., 11, 174, 183, 190
Wurm, K., 253
Wyse A. B., 177, 93, 181, 94, 221
- Y
Yale University, 220
Yerkes Observatory, 33, 23, 39, 45,
46, 48, 52, 202, 213, 218,
246, 247, 147
- Z
Zanstra, H., 191, 227
Zeeman effect, 95, 51b, 109
Zeta Aurigae, 119, 61
light variation of, 63
spectrum of, 62
Zwicky, F., 166

