

UNIVERSAL
LIBRARY

OU_158435

UNIVERSAL
LIBRARY

OSMANIA UNIVERSITY LIBRARY

Call No. 536.7/T81 G

Accession No. 14361

Author Trevor-J.E

Title *General theory of thermodynamics.*

This book should be returned on or before the date last marked below.

THE GENERAL THEORY OF THERMODYNAMICS

AN INTRODUCTION TO THE STUDY OF
THERMODYNAMICS

BY

J. E. TREVOR, PH. D.

PROFESSOR OF THERMODYNAMICS IN CORNELL UNIVERSITY



GINN AND COMPANY

BOSTON • NEW YORK • CHICAGO • LONDON
ATLANTA • DALLAS • COLUMBUS • SAN FRANCISCO

COPYRIGHT, 1927, BY J. E. TREVOR
ALL RIGHTS RESERVED
PRINTED IN THE UNITED STATES OF AMERICA

327.4

The Athenaeum Press
GINN AND COMPANY · PROPRIETORS · BOSTON · U.S.A.

TO
W. A. H.
IN RECOGNITION
OF MUCH HELPFUL COUNSEL

PREFACE

This little book is intended to serve as an introduction to the study of thermodynamics, and is planned for the use of students who have some acquaintance with the calculus of functions of more than one variable. Its distinctive purpose is to develop the general laws of thermodynamics with logical consecutiveness and mathematical clarity, and thus to establish these laws in a manner that can be thoroughly understood.

In the pursuit of cogency much care has been taken to leave no gaps in the chain of reasoning by which the results of the theory are obtained. For the same reason, various familiar expedients have been avoided. Thus no inexact differential expression is represented by the notation for a differential; no conclusions are based on the properties of non-existent "ideal gases"; and it is not assumed that the general reversible cyclic change of state of the general body must be the limiting effect of the operation of a set of Carnot cycles.

The text deals exclusively with general principles; no applications are considered. The treatment begins with the first law of thermodynamics, continues with the second law, the theorem of Carnot, the scale of absolute temperatures, and the entropy law, and is concluded by a critical study of the dissipation law and of an important deduction from it. Study of the text is facilitated by synopses of successive stages of the reasoning, and by a final review of the whole argument. A conscious effort has been made to distinguish sharply between theorems based on physical grounds and logical consequences deduced from such theorems. To ensure the correctness and completeness of the logical work, the physical theorems are formulated as mathematical statements, which are then developed by purely analytical means.

Some characteristic features of the book are as follows :

1. Attention is early directed to the existence of distinct regions of the states of thermodynamic equilibrium of a given

body. This increases the intelligibility of the subsequent exposition, and closes the door against the use of such misleading phrases as "the variables that determine the states (of thermodynamic equilibrium) of the body."

2. The difficult idea of reversibility is carefully explained.

3. The idea of a Carnot cycle is introduced with an unusual breadth of view. Thus cycles of different types are presented both in a diagram in space and in the projections of this diagram on the coordinate planes; a compression-expansion cycle having an isotherm at constant volume is shown; and the possibility of cycles in an isothermal region, and indeed of cycles of even more unexpected types, is indicated. Finally, to facilitate the applications of the second law, the useful concept of a chain or "sequence" of Carnot cycles is introduced, and attention is directed to no fewer than five distinct types of sequence which operate between equal end-temperatures.

4. It is proved that the quantity of work absorbed in the operation of a sequence has the sign of the quantity of heat absorbed on the lower terminal isotherm, and that these quantities vanish together. The theory fails in completeness of logical form if this essential preliminary theorem is merely more or less unconsciously assumed.

5. On the understanding that work W is absorbed by any sequence operating between temperatures t_1 and t_2 and absorbing heat x at t_1 , it is established, for all values of x and all relative values of t_1, t_2 , that W is a single-valued continuous function $W(x, t_1, t_2)$ of the independent x, t_1, t_2 , and that $W(x, t_1, t_1) = 0$.

6. The form of dependence of $W(x, t_1, t_2)$ on x is determined by solution of a certain functional equation; whereupon the theorem of Carnot is obtained.

7. Then the form of dependence of $W(x, t_1, t_2)$ on t_1, t_2 is determined by solution of another functional equation; whereupon it becomes clear that the absolute temperature is defined by a positive, increasing, single-valued, continuous function $\theta(t)$.

8. On the understanding that the heat-element for a selected auxiliary gas is a linear differential form DQ , it is shown, with the aid of Green's theorem, that the line integral of the expres-

sion DQ/θ , taken along any reversible cyclic change of state of the gas, is equal to zero. And it is made manifest that the reasoning employed provides a differential equation for the absolute temperature.

9. By coupling the general reversible cyclic change of state of the general body with a cyclic change of state of the auxiliary gas, it is then proved that the absolute temperature is an integrating divisor of any regional heat-element, which establishes the existence of the entropy of the body for the region. Stress is laid upon the fact that this result cannot be deduced unless it is known that the regional heat-element is a linear differential form.

10. In the deduction of the criterion of stability of the equilibrium of a body subject to no force other than a uniform and normally directed pressure,

$$\delta E + p\delta V - \theta\delta S \cong 0,$$

it is made clear that the quantities $\delta V, \delta S, \delta E$ are *finite differences*, and that the quantities p, θ are *constants*, — which denote the pressure and the absolute temperature of the body in the given state of equilibrium.

It is hoped that the book may be found useful as a classroom text in the teaching of thermodynamics to students of physics and of physical chemistry. Conceivably also it may attract the attention of mathematicians who would welcome an exposition which can be read in an evening or two. For it attempts to present in clear and correct form the minimum amount of thermodynamics that every mathematician should know. The book should also be of service to ambitious students of the thermodynamics of engineering, and to practicing heat-power engineers who wish to improve their understanding of the theory of their subject.

Acknowledgment is due to my son, Bertram, for the preparation of the drawings.

J. E. TREVOR

CONTENTS

CHAPTER	PAGE
<p>I. THERMODYNAMIC STATES OF BODIES.</p> <p style="padding-left: 2em;">Body, 1 · Temperature, 1 · Quantity of Heat, 2 · Thermodynamic State, 2 · Change of Thermodynamic State, 3 · Supplementary Changes of State, 3 · State of Thermodynamic Equilibrium, 3 · Regions of States of Thermodynamic Equilibrium, 4 · Synopsis, 7</p>	1
<p>II. THE ENERGY OF A BODY.</p> <p style="padding-left: 2em;">Equivalence of Work and Heat, 8 · Heat-Units, 8 · The First Law of Thermodynamics, 9 · The Energy Law, 10 · Different Paths, 11 · Conservation of Energy, 13 · A Warning, 13 · Synopsis, 14</p>	8
<p>III. SEQUENCES</p> <p style="padding-left: 2em;">Compression and Expansion, 15 · Reversible Paths, 16 · Paths not Reversible, 19 · Carnot Cycles, 20 · Varieties of Carnot Cycles, 25 · The Case $t_2 = t_1$, 26 · Sequences, 27 · Synopsis, 30</p>	15
<p>IV. THE SECOND LAW OF THERMODYNAMICS</p>	32
<p>V. A THEOREM ON SEQUENCES</p>	34
<p>VI. THE WORK ABSORBED BY A SEQUENCE</p> <p style="padding-left: 2em;">W is Independent of the Working Bodies, 38 · The Function W, 41 · Synopsis of Chapters IV, V, VI, 42</p>	38
<p>VII. THE FORM OF THE FUNCTION W IN x</p> <p style="padding-left: 2em;">Dependence of W upon x, 43 · Synopsis, 44</p>	43
<p>VIII. THE FORM OF THE FUNCTION W IN t_1, t_2</p> <p style="padding-left: 2em;">Dependence of W upon t_1, t_2, 45 · Formulating the Increment of W, 45 · Theorems and Equations for Reference, 46 · A Functional Equation for $q(t_1, t_2)$, 46 · The Reciprocal of $q(t_1, t_2)$, 46 · The Sign of $q(t_1, t_2)$, 47 · The Form of $q(t_1, t_2)$, 47 · The Form of the Function $W(1, t_1, t_2)$, 48</p>	45
<p>IX. THE ABSOLUTE TEMPERATURE</p> <p style="padding-left: 2em;">The Ratio Q/x, 49 · Definition of the Absolute Temperature, 49 · Synopsis of Chapters VIII and IX, 50</p>	49

x GENERAL THEORY OF THERMODYNAMICS

CHAPTER	PAGE
X. THE GENERAL CYCLIC CHANGE OF STATE OF AN AUXILIARY FLUID	52
A Theorem on Carnot Cycles, 52 · An Auxiliary Fluid, 52 · Formulation of the Theorem on Carnot Cycles, 53 · The General Cyclic Change of State of the Fluid, 54 · The Case of n Variables, 55 · The Absolute Temperature, 55 · Synopsis, 57	
XI. THE ENTROPY OF A BODY	59
The General Cyclic Change of State, 59 · Heat-Elements, 60 · The Entropy of a Body, 61 · The Formulation of Heat-Elements, 62 · Integrating Factors of Heat-Elements, 64 · Synopsis, 68	
XII. THE SCALE OF ABSOLUTE TEMPERATURES	70
A Differential Equation for θ , 70 · The Porous Plug Effect, 71 · A New Differential Equation for θ , 72 · Exercise, 73 · Synopsis, 73	
XIII. DISSIPATION	75
Paths of Least Resistance, 75 · Processes of Diverse Types, 76 · Uncontrollable Processes, 82 · The Postulate of Dissipation, 84 · Thermally Isolated Bodies, 85 · Synopsis, 87	
XIV. A CRITERION OF STABILITY	89
An Application of the Dissipation Law, 89 · A Criterion of Stability, 90 · Synopsis, 92	
XV. REVIEW	94
Definitions, 94 · Energy, 94 · Reversibility, 94 · The Second Law, 95 · The Function W , 95 · Dependence of W on x , 95 · Dependence of W on t_1, t_2 , 96 · Absolute Temperature, 97 · A Theorem on Carnot Cycles, 98 · Entropy, 98 · Scale of Absolute Temperatures, 100 · Dissipation, 100 · An Analogy, 100	
INDEX	103

THE GENERAL THEORY OF
THERMODYNAMICS

THE GENERAL THEORY OF THERMODYNAMICS

CHAPTER I

THERMODYNAMIC STATES OF BODIES

Body. In this book the term *body* will be employed to designate a definite material object. If the object is to remain a body, no part of it may be removed and no material may be added to it while it is under consideration. A quantity of liquid water *together with* a quantity of overlying steam is a body; but the liquid portion of this object is not a body when a rise of the temperature of the object converts a part of the liquid into steam. If a body *B* consists of separate masses of ice and common salt, it remains the body *B* when the ice is melted, when the salt is dissolved in the liquid thus formed, and when the resulting solution is partly decomposed by electrolysis. The physical and chemical condition of an object may be altered in any way without the object's ceasing to be a body.

Temperature. A thermometer is an instrument whose numerical scale readings increase with the hotness of the instrument, and may be considered to be in continuous one-to-one correspondence with the degree of this hotness. It may be an ordinary mercury-in-glass thermometer, a platinum-resistance thermometer, a gas thermometer filled with hydrogen or with some other gas, or a mere column of kerosene in a slender glass tube of uneven bore. For the present we shall make no selection. We shall consider the scale readings of any particular instrument to be values of the *temperature* t of that particular *arbitrary* scale.

The temperature of a body may be *uniform* or not, and if uniform it may be *constant* or not. When uniform and constant it

2 GENERAL THEORY OF THERMODYNAMICS

may be measured by establishing temperature equilibrium between the body and a thermometer, since it is observed that contiguous bodies having different temperatures come spontaneously to a common temperature. The uniform temperature t of a body is a real variable.*

The standard temperature scales are those of the constant volume gas thermometer filled with an arbitrary mass of hydrogen supporting the pressure p_1 of 100 cm of mercury at the freezing temperature of water. On the centigrade and Fahrenheit scales the freezing temperature t_1 and the boiling temperature t_2 of water under the pressure 1 atm are set at

$$\begin{aligned}t_1 &= 0^\circ \text{C}, & t_2 &= 100^\circ \text{C}; \\t_1 &= 32^\circ \text{F}, & t_2 &= 212^\circ \text{F}.\end{aligned}$$

When the temperature of the hydrogen is raised, its pressure becoming p_2 at t_2 , the temperature increases one centigrade degree of the hydrogen scale with each increment $(p_2 - p_1)/100$ of the pressure, and it increases one Fahrenheit degree with each increment $(p_2 - p_1)/180$ of the pressure.

Quantity of Heat. When a hot block of copper is in contact with a cold block of iron, when a hot bullet is dropped into ice, and when a kettle of water boils on a hot stove, "heat" is said to pass from the copper to the iron, from the bullet to the ice, and from the stove to the boiling water. In general, *quantities of heat* are defined with reference to measurement by means of a calorimeter, and the unit in which the measurement is expressed is the quantity of heat requisite to raise the temperature of unit mass of water one degree on a specified temperature scale, under a specified constant pressure.

Thermodynamic State. The thermal and mechanical properties of a given body of gas can be altered by heating or cooling the body, and by compressing or expanding it. In general, the thermal and mechanical properties of any body can be altered by positively or negatively adding *heat* and *work* to it. When this is done we shall say that the *thermodynamic state* of the body has been altered.

* For an interesting and thoughtful historical and critical discussion of thermometry, see Mach, *Wärmelehre*, pp. 3-77. Leipzig, 1896.

Change of Thermodynamic State. By a *change of thermodynamic state* of a body shall be meant a transformation of one thermodynamic state into another. It is determined solely by the end states. The *path* of a change of state is the set of intermediate states. A given change of state can occur on different paths; as when a body of gas is slowly expanded from an initial volume V_1 to a final volume V_2 at constant temperature; or is expanded from V_1 to V_2 when thermally insulated, and its consequent fall of temperature is overcome by adding heat at the constant volume V_2 ; or is allowed to expand abruptly into an exhausted space having the volume $V_2 - V_1$, any consequent change of temperature being corrected by subsequent addition or abstraction of heat.

Supplementary Changes of State. If a heavy piston confines a body of air in a vertical cylinder, and the released piston falls to a lower position with a consequent decrease of volume and increase of temperature of the air, the changes of state of the piston and of the air shall be said to *supplement* each other. If two blocks of metal having initially different temperatures are brought into contact, whereby both come to a common temperature, the change of state of each block *supplements* that of the other. In general, supplementary changes of state are the concurrent changes of state of two bodies, which together constitute the set of all the bodies participating in the process.

State of Thermodynamic Equilibrium. When a body has a constant uniform temperature and all its parts are at rest, it shall be said to be in a state of *thermodynamic equilibrium*. For it is then in thermal and in dynamic equilibrium with the contiguous bodies. The state of thermodynamic equilibrium of a body of gas can be specified by numerical values of its temperature and of the pressure that it supports. The state of a body of liquid water and overlying steam in a closed boiler can be specified by the values of the temperature of the body and of the volume that it occupies. In any case it is always possible similarly to describe the state of thermodynamic equilibrium of a given body by a set of numerical specifications that are sufficient for the purpose to be served. In some cases the quantities

4 GENERAL THEORY OF THERMODYNAMICS

specified may be the imposed forces and the imposed temperature. In other cases they may not. The state of a body of coexistent water and steam, for example, cannot be specified by values of the pressure and the temperature of the body.

Regions of States of Thermodynamic Equilibrium. It is very important to realize that the states of thermodynamic equilibrium of a given body lie usually, if not always, in contiguous regions of state that are wholly distinct from one another. This circumstance is illustrated by Fig. 1, in which the pressure p atm of carbon dioxide is plotted against the specific volume v cm³ (the volume of one gram) and the temperature t deg C of a body of the substance. The figure is a graph of the surface

$$p = f(v, t),$$

for a restricted range of each of the variables.

The surface is crossed from left to right by a number of isothermal lines in which planes perpendicular to the axis of t cut the surface. An isotherm for a temperature near 0 deg C falls steeply through the liquid field as the volume increases in isothermal expansion of the liquid; then horizontally traverses the evaporation field as evaporation proceeds at constant temperature and pressure; and finally falls gently through the vapor field in isothermal expansion of the resulting vapor. The evaporation field thus forms a cylindrical surface, perpendicular to the t, p plane and terminating at the "critical point," where it touches the isotherm $t = 31.35$ deg C = 88.4 deg F. The highest isotherm in the figure traverses the field for homogeneous fluid, without a break.

From any point in the liquid field, a fall of temperature at constant pressure carries the representative point to the edge of a steep narrow cylindrical surface representing the fusion field, which the representative point traverses in the conversion of liquid into solid. Further cooling carries the point into the steep surface representing solid states at low temperatures.

Under the high pressure $p = 2800$ kg/cm² = 271 atm = 4000 lb/in², as is represented in the smaller figure, the cylindrical fusion field meets two similar cylinders. In the first of these the ordinary

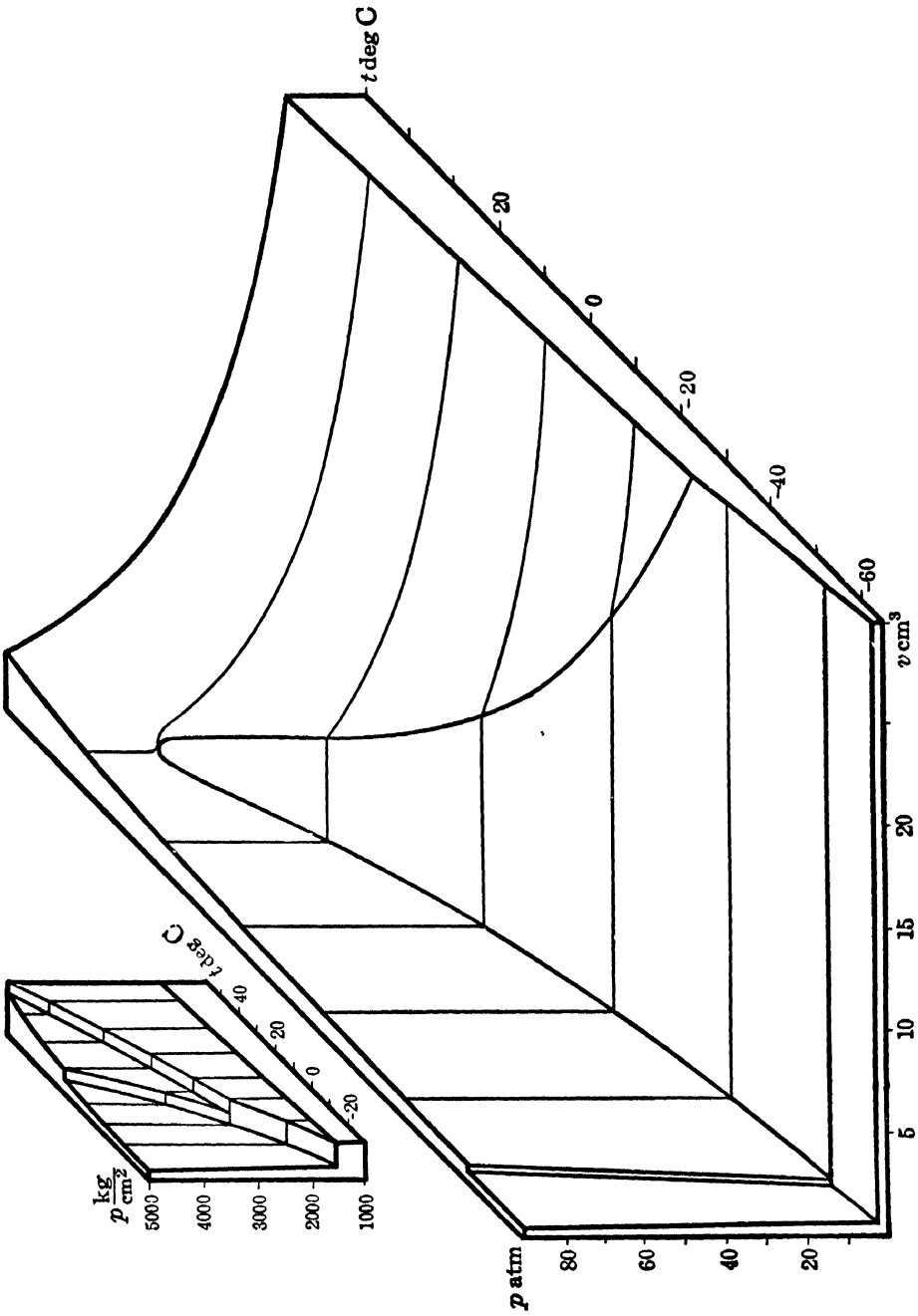

FIG. 1

solid is converted into a less dense solid form, and in the second this form is converted into liquid. So the last cylinder is a fusion field separating the field of the less dense solid states from the field for liquid.

It is thus clear that the fields for homogeneous fluid, for the ordinary solid, and for the less dense solid, as also the evaporation field, the field for transformation of the two solids, and the two fusion fields, form contiguous regions of state that are wholly distinct from one another. The function

$$p = f(v, t),$$

whose graph we are considering, has different *forms* in the different regions.

Then, too, it should be noted that the states of certain regions are not determined by the variables v, t at all. Other variables must be chosen. For example, in Fig. 1 consider the horizontal isotherm that is drawn through the point where the fusion field meets the evaporation field. A point on this line represents a state of coexistent liquid, vapor, and solid masses. By slow heating or cooling, the distribution of the total mass between these "phases" is continuously altered at constant v, t , and p . Hence a single point represents a continuous set of states; the variables v, t do not determine the states. At times it may even be desirable to employ different sets of independent variables for different regions. If p, t are chosen independent in a field of vapor states, another choice must be made for the contiguous evaporation field. For these variables do not determine states of coexistent masses of liquid and vapor.

The foregoing illustration is a simple one. More extensive possibilities are afforded by mixtures. When the state of an unsaturated solution of common salt in water is varied by compression or expansion and heating or cooling, we can obtain states of coexistent solution and vapor, or solution and ice, or solid salt and vapor, or salt and ice; we can obtain states of coexistent masses of any three of the phases: solution, salt, vapor, and ice; and we can obtain states in which all four phases coexist. The possibilities are increased when water is mixed with a salt which combines with it to form solid hydrates

of definite compositions. In general, the realizable states of thermodynamic equilibrium of a given body form distinct regions of state. And it must be remembered that the states of different regions are not always determined by the same independent variables.

Synopsis. A *body* is a definite material object. The uniform *temperature* t of a thermometer, expressed with reference to an arbitrary scale, is a real variable. A *quantity of heat* is a measurable quantity. Changes of physical state effected by adding positive or negative quantities of heat and work to a body are changes of *thermodynamic state*. A *change of state* is the transformation of one state into another; it is determined by the end states. The *path* of a change of state is the set of intermediate states. When an entire thermodynamic process consists of changes of state of two bodies, these changes of state *supplement* each other. When a body has a constant uniform temperature, and is at rest, it is in a state of *thermodynamic equilibrium*. The states of thermodynamic equilibrium of bodies form in general distinct continuous *regions* of states.

CHAPTER II

THE ENERGY OF A BODY

Equivalence of Work and Heat. It is a familiar fact that expenditure of work against friction produces heat. And it is a well-known experimental fact that *any mechanical operation expending a quantity of work against friction supplements an absorption of a quantity of heat proportional to the work expended.*

It follows that every absorption or development of heat by a body has a mechanical aspect, in that an absorption can be imagined supplemented by a mechanical operation, and a development can be imagined replaced by one. Hence quantities of work and of heat can be expressed in the same unit. If a development of 5 foot-pounds of work supplements an absorption of 1.62 calories of heat, we may say that 5 foot-pounds of work is developed and 5 foot-pounds of heat is absorbed; or we may say that 1.62 calories of work is developed while the equal quantity of heat is absorbed. *Henceforth, whenever quantities of work and of heat are considered together, it shall be understood that they are expressed in the same unit.*

Heat-Units. Various heat-units are in use. The *standard calory* is the quantity of heat requisite to raise the temperature of one gram of water from 15° to 16° on the centigrade scale of the standard hydrogen thermometer, under the pressure of one atmosphere. The *mean calory* is $\frac{1}{100}$ of the quantity of heat absorbed when the temperature change is from the freezing to the boiling temperature, under the same pressure. The *British thermal unit*, the "*B.t.u.*," is the quantity of heat absorbed by one pound of water when its temperature rises one degree from $t = 60^{\circ}$ on the Fahrenheit scale of the hydrogen thermometer under atmospheric pressure. Note that $60^{\circ} \text{ F} = 15.5^{\circ} \text{ C}$. The *mean B.t.u.* is $\frac{1}{180}$ of the quantity of heat absorbed when the

temperature change is from the freezing to the boiling temperature. The "mean" units are more accurately known than the others described, because of the disturbing effect of the steepness with which the specific heat of water changes near 60° F. A conversion table, with entries to three significant figures, is inserted here to direct attention to the relative values of various units. The letter *t* in the table stands for *ten*. Thus

$$2.33 t^{-3} = 2.33 \times 10^{-3} = 0.00233.$$

CONVERSION TABLE

g-cm	ft-pdl	Joule =10 ⁷ erg	ft-lb	Mean cal	lit-atm	Mean B.t.u.	ft ³ -atm	Watt-hr	H.p.-hr
1.00	2.33 <i>t</i> ⁻³	9.81 <i>t</i> ⁻⁵	7.23 <i>t</i> ⁻⁵	2.34 <i>t</i> ⁻⁵	9.68 <i>t</i> ⁻⁷	9.30 <i>t</i> ⁻⁸	3.42 <i>t</i> ⁻⁸	2.72 <i>t</i> ⁻⁸	3.65 <i>t</i> ⁻¹¹
4.30 <i>t</i> ²	1.00	4.21 <i>t</i> ⁻²	3.11 <i>t</i> ⁻²	1.01 <i>t</i> ⁻²	4.16 <i>t</i> ⁻⁴	4.00 <i>t</i> ⁻⁵	1.47 <i>t</i> ⁻⁵	1.17 <i>t</i> ⁻⁵	1.57 <i>t</i> ⁻⁸
1.02 <i>t</i> ¹	2.37 <i>t</i>	1.00	7.38 <i>t</i> ⁻¹	2.39 <i>t</i> ⁻¹	9.87 <i>t</i> ⁻³	9.49 <i>t</i> ⁻⁴	3.49 <i>t</i> ⁻⁴	2.78 <i>t</i> ⁻⁴	3.73 <i>t</i> ⁻⁷
1.38 <i>t</i> ⁴	3.22 <i>t</i>	1.36	1.00	3.24 <i>t</i> ⁻¹	1.34 <i>t</i> ⁻²	1.29 <i>t</i> ⁻³	4.73 <i>t</i> ⁻⁴	3.77 <i>t</i> ⁻⁴	5.05 <i>t</i> ⁻⁷
4.27 <i>t</i> ⁴	9.93 <i>t</i>	4.18	3.09	1.00	4.13 <i>t</i> ⁻²	3.97 <i>t</i> ⁻³	1.46 <i>t</i> ⁻³	1.16 <i>t</i> ⁻²	1.56 <i>t</i> ⁻⁶
1.03 <i>t</i> ⁶	2.41 <i>t</i> ³	1.01 <i>t</i> ²	7.47 <i>t</i>	2.42 <i>t</i>	1.00	9.61 <i>t</i> ⁻²	3.53 <i>t</i> ⁻²	2.81 <i>t</i> ⁻²	3.77 <i>t</i> ⁻⁵
1.08 <i>t</i> ⁷	2.50 <i>t</i> ⁴	1.05 <i>t</i> ³	7.77 <i>t</i> ²	2.52 <i>t</i> ²	1.04 <i>t</i>	1.00	3.67 <i>t</i> ⁻¹	2.93 <i>t</i> ⁻¹	3.93 <i>t</i> ⁻⁴
2.93 <i>t</i> ⁷	6.81 <i>t</i> ⁴	2.87 <i>t</i> ³	2.12 <i>t</i> ³	6.86 <i>t</i> ²	2.83 <i>t</i>	2.72	1.00	7.97 <i>t</i> ⁻¹	1.07 <i>t</i> ⁻³
3.67 <i>t</i> ⁷	6.79 <i>t</i> ⁴	3.60 <i>t</i> ³	2.66 <i>t</i> ³	8.61 <i>t</i> ²	3.55 <i>t</i>	3.42	1.25	1.00	1.34 <i>t</i> ⁻³
2.74 <i>t</i> ¹⁰	7.37 <i>t</i> ⁷	2.68 <i>t</i> ⁶	1.98 <i>t</i> ⁶	6.42 <i>t</i> ⁵	2.65 <i>t</i> ¹	2.55 <i>t</i> ³	9.36 <i>t</i> ²	7.46 <i>t</i> ²	1.00

The First Law of Thermodynamics. When a falling weight coils a spring to which it is attached, the weight develops work and the spring absorbs it. Work is *transferred* from the weight to the spring. Similarly heat is transferred from a hot body to a contiguous cold one. When a quantity of work is expended against friction it is *transformed* into an equal quantity of heat, the work and the heat being measured in the same unit. In processes such as these work and heat may indeed be interconverted, but taken together they are neither created nor destroyed. Let us then consider the assumption that work and heat (measured in the same unit), however they may be transferred from body to body and transformed into each other, are not thereby changed in total amount.

Let any body traverse any closed path of change of its thermodynamic state, thus regaining its initial state. The cyclic process serves as a means of transforming the work and heat received by the body into the work and heat given out by it. If W_c and Q_c are the algebraic sums of the quantities of work and of heat absorbed by the body, the result is to create the quantity $W_c + Q_c$ of work and heat if this sum be negative, or to destroy this quantity if the sum be positive. Continued repetition of the process would effect boundless creation or destruction of work or heat or both. Under our assumption, then, we shall have

$$W_c + Q_c = 0. \quad (1)$$

To express the assumption in more convenient form, let W_1, Q_1 be the total work and heat absorbed by the body on any selected path of change of thermodynamic state from any state a to any other state b ; let W_2, Q_2 be the work and heat absorbed on any other path of the change of state; and let W_3, Q_3 be the quantities absorbed on any possible path of the reversed change from b to a . Then the first path followed by the third, and the second path followed by the third, are closed paths, for which the equation (1) requires that

$$\begin{aligned} (W_1 + Q_1) + (W_3 + Q_3) &= 0, \\ (W_2 + Q_2) + (W_3 + Q_3) &= 0. \end{aligned}$$

It follows that

$$W_1 + Q_1 = W_2 + Q_2,$$

which means that *the algebraic sum of the work and heat absorbed by a body in any change of its thermodynamic state is independent of the path of the change of state*. This principle is termed the *first law of thermodynamics*. Since it is justified by the extended and exact agreement of its consequences with experience, it is to be regarded as an experimentally established truth. It is not a consequence of any theory; it is an *experimental fact*.

The Energy Law. From the first law it follows immediately that the sum of the work and heat absorbed by a body in a change of its thermodynamic state is equal to the concurrent change of value of a function of the independent variables that are employed to determine the states. This function is termed

the *energy* of the body. In technical thermodynamics (the thermodynamics of engineering) the terms "inner energy" and "internal energy" are in common use. When the work W_{ab} and the heat Q_{ab} are absorbed by the body on any possible path of the change of its state from any state a to any other state b , the change of the energy of the body is

$$E_b - E_a = W_{ab} + Q_{ab}. \quad (2)$$

It is clear that the energy E is single valued. And, since *sufficiently* small changes of the variables (that is, of the state) effect *arbitrarily* small changes of the function, we are justified in considering the function to be *continuous*. In formal terms:

The algebraic sum of the work and heat absorbed by a body in a change of its thermodynamic state is equal to the concurrent change of the value of a single-valued continuous function E of the variables that determine the states of the body.

This formal statement is the *energy law*. Since only *changes* of value of the energy of a body are defined, this quantity contains an arbitrary additive constant. This condition is met by arbitrarily assigning the value zero to the energy at some conveniently located *state of reference* of the body. Hereupon the energy at any other state becomes the excess of the energy at that state over the energy at the state of reference. When the work W_{rs} and the heat Q_{rs} are absorbed on any possible path of change from the state of reference r to the general state s , the energy E of the body at its general state is expressed by

$$E = W_{rs} + Q_{rs}. \quad (3)$$

Different Paths. The work and the heat absorbed by a body in a change of its thermodynamic state vary in general with the path of the change. Thus the temperature of a body of water may be raised through expenditure of work in driving an immersed paddle, or it may be raised by an addition of heat alone, or it may be raised by adding any part of the energy increment as work and the remainder as heat. Again, suppose a body of air to be brought from a volume V_1 under the pressure p_1 to a smaller volume V_2 under an increased pressure p_2 , whereby its

energy changes from E_1 to E_2 (see Fig. 2). If the path is a cooling from V_1 to V_2 at constant pressure, followed by a heating at constant volume, the work and heat absorbed are

$$p_1(V_1 - V_2), \quad (E_2 - E_1) - p_1(V_1 - V_2);$$

while, if the path is a heating at constant volume from p_1 to p_2 , followed by a cooling at constant pressure, the work and heat absorbed are the different quantities

$$p_2(V_1 - V_2), \quad (E_2 - E_1) - p_2(V_1 - V_2).$$

By the definition (3), the energy E is a function of the variables W_{rs} and Q_{rs} regarded as independent. But on different paths of the change of state from r to s the quantities W_{rs} , Q_{rs} have in general different values. Hence given values of these variables, though they determine the value of E , do not determine the state of the body; the points of the plane (3) are not in one-to-one correspondence with the states of the body.

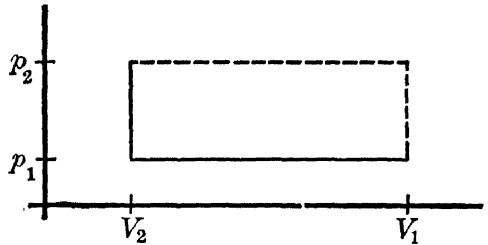

FIG. 2

The position resembles that observed in the operation of a freight elevator. The state of the elevator car is determined by its height h and total weight w , and the energy e of the car is a function of these variables :

$$e = wh.$$

Hence

$$de = wdh + hdw,$$

where the inexact expression $w dh$ denotes the work absorbed in the change of height dh , and the inexact expression $h dw$ denotes the potential energy absorbed in the change of load dw . On any assigned path of change of the state of height and weight of the car, from that of the empty car at the level of reference, the work W and the potential energy Q absorbed are line integrals

$$W = \int w dh, \quad Q = \int h dw,$$

and we have

$$e = W + Q.$$

The energy e is indeed a function of the independent W and Q , but these quantities do not determine the state of the car.

Conservation of Energy. The energy law involves the theorem that the sum of the changes of the energies of bodies undergoing mutually supplementary thermodynamic changes of state is zero,—that the energy of a body undergoing an unsupplemented change of thermodynamic state is constant. This theorem is the law of the *conservation of energy*. When the supplementary changes of state are purely thermal, the one body loses energy and the other gains it by the amount of the heat transferred. Only in this case is the quantity of heat conserved. Conservation of heat in purely *thermal* supplementary changes of state, and conservation of mechanical energy in purely *mechanical* supplementary changes of state, are limiting cases of the conservation of energy. Presumably neither case is ever fully realized.

A Warning. The reader is warned not to yield, at this point, to the temptation to express the energy law (2) by the equation

$$dE = dW + dQ, \quad (a)$$

or even by the equation

$$dE = DW + DQ, \quad (b)$$

where the symbols DW, DQ denote inexact linear differential expressions. The formulation (a) asserts that the work and heat absorbed by a body undergoing a change of thermodynamic state are integrals of exact differential expressions. But the assertion is in general not true. The formulation (b) asserts that this work and heat are line integrals of inexact differential expressions in the variables. But no information about the possibility of formulating quantities of work and heat by such integrals is available at this point. When we arrive at the consideration of reversibility, we shall indeed find that (b) expresses the energy law with reference to *reversible* paths of change of state — and to these only. Hence (b) not only expresses something that is not known at this point, but it also fails to express the whole of the energy law. What *is* known at the present

14 GENERAL THEORY OF THERMODYNAMICS

stage is that the sum of the work and heat absorbed is independent of any possible reversible or irreversible path between the terminal states, — and the equation (2) formulates exactly this.

Synopsis. Any mechanical operation expending work against friction supplements an absorption of a quantity of heat proportional to the work expended. Hence quantities of work and of heat can be expressed in the same unit. Henceforth it shall be understood that they are so expressed. The algebraic sum of the work and heat absorbed by a body in any change of its thermodynamic state is independent of the path of the change of state. This experimental fact is the “first law of thermodynamics.” It follows that the sum in question is equal to the concurrent change of the value of a single-valued continuous function E of the variables that determine the state of the body,

$$E_b - E_a = W_{ab} + Q_{ab}.$$

This equation expresses the “energy law.” The energy E of the body, since it contains an arbitrary additive constant, is set equal to zero at an arbitrarily selected state of reference. The work and heat absorbed by a body in a change of its thermodynamic state vary in general with the path of the change. The energy of a body undergoing an unsupplemented change of thermodynamic state is constant.

CHAPTER III

SEQUENCES

Compression and Expansion. When a body is compressed by the action of an imposed pressure it absorbs work. When it expands against an opposing pressure it develops work. To illustrate, let a mass of gas, the temperature of which is independently variable, be confined in a horizontal cylinder by a piston operating without friction, and let us formulate the work that must be expended to effect a slow compression of it. Let p be the pressure of the gas, while a is the area of a cross section of the cylinder, and s is the distance of the piston from the cylinder head. Then the work of the force pa , acting through the distance $-ds$ in the process of compression, is the "work-element"

$$- pa \cdot ds.$$

But ads is the differential of the volume $V = as$ of the gas, of mass m , and V is connected with the volume v of unit mass by the relation $V = mv$. Hence the work-element becomes

$$- pads = - pdV = - m \cdot pdv.$$

It follows that the work expended in compressing the gas from a state (v_1, p_1) to a state (v_2, p_2) is given by the expression

$$- m \int_{v_1}^{v_2} pdv. \quad (4)$$

Any path of compression is realizable by appropriate variation of the temperature of the gas. Since the integral in (4) is represented geometrically by the area swept over by the ordinate of the representative point in the v, p plane, it is obvious that the work of compression is different for the two paths indicated in Fig. 3, and that in general this work depends on the path. In other words, the integral has no definite meaning unless p is some particular function of v . This function is represented

graphically by some path from (v_1, p_1) to (v_2, p_2) , and we then speak of integrating over this path. Since the integral of the differential expression $-pdv$ depends on the path of integration, this expression is *not the differential of a function* of the independent variables v, p . It is an *inexact differential expression*, and the integral is a *line integral*.

In general, when the state of a body lies in a region of states of thermodynamic equilibrium, the volume V of the body and the uniform and normally directed pressure p that the body supports are functions of the independent variables that determine the states of the region. Then,

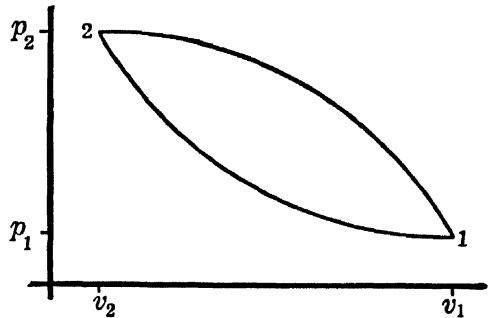

FIG. 3

just as in the foregoing case, the work absorbed by the body when it is compressed or expanded along a slowly traversed path is a line integral

$$-\int pdV$$

of the inexact expression $-pdV$ in the independent variables. As before, this work depends in general on the path.

Reversible Paths. A continuous one-dimensional set of states of thermodynamic equilibrium, connecting two arbitrary states a and b of a given body, is not a path of the change of state ab . But the set may be the limit approached by the paths of a family of paths of the change of state ab , and also of the reversed change of state ba , when these changes of state are conducted with extreme slowness under the influence of the independently controlled imposed forces and temperature. When the prescribed set is such a limit it is termed a prescribed *reversible path* of the change of state ab , and of the reversed change of state ba . And the limits of the quantities of work and heat absorbed on the paths of the change ab , which are equal to the negatives of the limits of the work and heat absorbed on the paths of the change ba , as the limiting path is approached, are termed the

work and heat absorbed *on the reversible path* ab , or developed on the reversible path ba .

The idea that a continuous one-dimensional set of states of equilibrium is a limiting path that can be imagined realized, to any degree of approximation, by an actual path of change of state requires further elucidation. The following is a very simple illustration. If a lead ball weighing five pounds falls through a fixed difference of level, while hauling up a four-pound counterpoise, the path of its change of state involves a definite velocity at each level. If the process be repeated with successive counterpoises whose weights approach the limit five pounds, — and if then the ball *rise* through the level-difference under the influence of successive counterpoises whose weights 6.0, 5.9, . . . again approach the limit five pounds, — we observe that the two families of paths, of the change of state and of the reversed change of state, have the same limiting path, which is a set of states of equilibrium. And we observe that the limit of the quantities of work *developed* by the ball on the paths of the downward family is equal to the limit of the quantities of work *absorbed* on the paths of the upward family, and is equal to the product of the weight of the ball into the change of its level. The set of states of equilibrium is termed a *reversible path* of either change of state. And the limiting quantity of work is termed the work developed, or absorbed, on the reversible path.

The idea of a reversible path of a *thermodynamic* change of state is wholly similar. To illustrate, let a body of some gas, while thermally insulated, expand with extreme slowness against an opposing pressure that at each moment almost exactly counterbalances the decreasing pressure of the gas. The path of the change of state, which is represented by the path ab in each diagram of Fig. 4, is sensibly a set of states of thermodynamic equilibrium. Now, obviously, this path can be approximated by paths of expansion against pressures less nearly equal to the momentary pressures of the gas; and it can be approximated by paths of compression under the action of pressures exceeding the pressures of the gas. In either case, as complete balance is approached, the prescribed set of states of equilibrium is the limit of the paths of the family of paths contemplated. This

common limit is the *reversible path* of the expansion, or of the compression, under the imposed condition of thermal insulation. And the limiting quantity of work transferred, which is represented by the area swept over by the ordinate of the representative point in the V, p plane, is termed the work developed in the expansion, or absorbed in the compression, "on the reversible path."

Through the point a in the figures any number of lines representing reversible paths can be drawn. The three solid lines ac

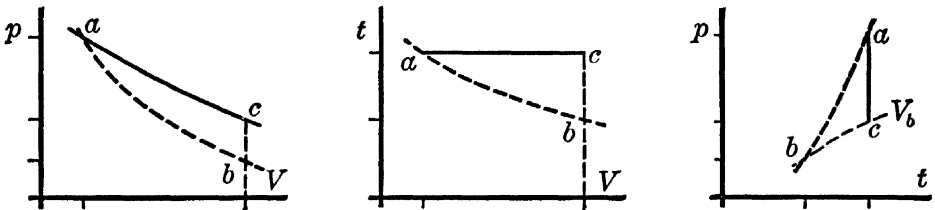

FIG. 4

represent a reversible *isothermal* path. This is an isothermal set of states of equilibrium, and here again the set of states can be approximated by paths of expansion or compression on which the imposed pressures and temperatures differ more or less widely from the coordinates of the prescribed path, as they appear in the t, p plane. The common limit of these paths is the *reversible path* of the isothermal expansion or compression; and the common limits of the work-transfers and of the heat-transfers are the work and heat transferred to or from the body "on the reversible path."

Nowhere do the foregoing considerations contemplate that a path in any one of the figures is approximated by neighboring paths in the same plane. For, when a region of the plane corresponds to a field of states, the points of the region correspond to states of thermodynamic equilibrium. Hence any curve in the region depicts a *reversible path*. An *irreversible path* is not a set of states of equilibrium, and so cannot be depicted by a curve in the plane.

A reversible path does not necessarily involve a balance of purely *mechanical* forces. Electrical forces, for example, may be in balance. In a constant galvanic cell developing or absorbing

a current so vanishingly small that the development of heat in the connecting wire, proportional to the resistance and to the square of the current, can be neglected as an infinitesimal of the second order, the processes occurring are perfectly reversible.

Paths not Reversible. It may be observed that, although a reversible path is a set of states of equilibrium, a continuous one-dimensional set of states

of equilibrium is not necessarily a reversible path. Let us assume the existence of a cubical block of some material, perhaps lead, having a definite limit of elasticity $p = \pi(t)$ at any temperature within the range of temperatures considered. We assume that under the pressure

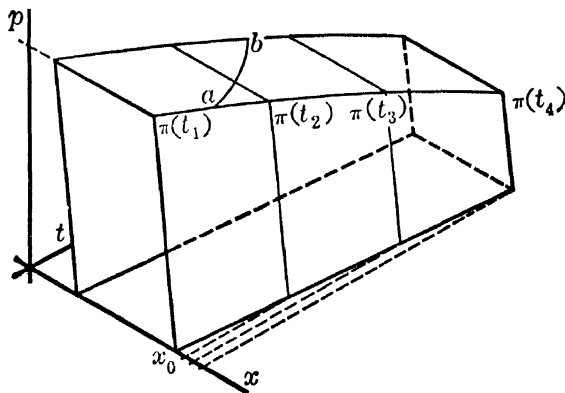

FIG. 5

$p = \pi$ applied to its upper face, the block is in a state of thermodynamic equilibrium; that under pressures $p < \pi$, the block is perfectly elastic and its state of thermodynamic equilibrium is determined by the values of p, t ; and that pressures $p > \pi$ are crushing pressures.

In Fig. 5 let x_0 be the value of the vertical thickness x of the block under the pressure $p = 0$ at $t = t_1$. We assume that x decreases under compression at any constant temperature t as p rises from zero to $\pi(t)$; and we assume that x increases by thermal expansion at any constant pressure p as t rises to the value that is the root of $\pi(t) = p$. We thus find a surface of elastic states

$$p = f(x, t),$$

bounded above by the locus of the values of π . Now, application of any crushing pressure $p > \pi$ displaces this surface to the left and causes the locus $p = \pi(t)$ to describe a cylinder perpendicular to the t, p plane. The points of this cylinder represent states of thermodynamic equilibrium, the region below it is the

region of perfect elasticity for any constant value of x_0 , and the region above it is the region in which crushing occurs. Paths in the region of elasticity are reversible paths; paths for which $p > \pi$ are irreversible.

Any path ab in the cylindrical surface, described with continuously decreasing x , is a set of states of equilibrium, and this set is the limit of a family of paths ab realizable by independent variation of t and application of a crushing pressure whose values approach the values of the elastic limit π on the given path. But the reversed path ba is not the limit of a family of realizable paths. For, at the state b , pressures $p > \pi$ decrease x , pressures $p < \pi$ describe paths in the surface $p = f(x, t)$ for a constant x_0 , and the pressure $p = \pi(t_b)$ maintains equilibrium. No value of p serves to increase x . The path ab is a set of states of equilibrium, but it is not a reversible path.

Other cases in which states of equilibrium, for given values of the independent variables, depend on the previous thermodynamic history of the body appear to be not uncommon. Such processes as the displacement of the zero of mercury thermometers and the hydration of colloidal jellies seem to fall into this category.

Carnot Cycles. We are now in position to turn our attention to considerations that first came to light in connection with the endeavor to establish a theory of the steam engine, at a time when the improvement of this apparatus had become a problem of pressing technical importance. In the operation of a steam power plant the working fluid absorbs heat at a high temperature in the boiler, develops work, and develops heat at a low temperature in the condenser. The process bears some resemblance to the operation of the car of a freight elevator, which absorbs potential energy with an increment of load at a high level, develops work, and develops potential energy when it is unloaded at a low level. This analogous operation is easily studied. If the *height* of the car is given with reference to an *irregular* scale of heights in the elevator shaft, and we know the quantities of potential energy transferred to and from the car and the quantities of work exchanged with the hoisting appa-

ratus, we can determine the actual changes of level and the changes of load, — though in arbitrary units.

There is no present need to work out the details of this calculation. In the operation of the elevator potential energy is absorbed at a definite height, work is developed, potential energy is developed at a lesser height, and the elevator is restored to its initial state. In an analogous thermodynamic operation a body would absorb heat at one temperature, would develop work, would develop heat at a lower temperature, and would be returned to its initial state. If the *temperature* of the body is given with reference to an *arbitrary* scale of temperatures, and we know the quantities of heat transferred and the quantities

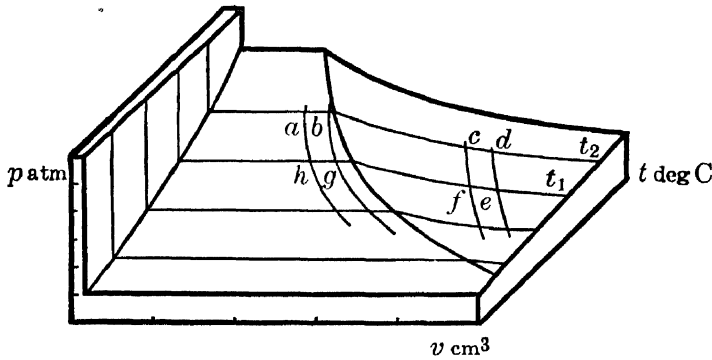

FIG. 6

of work exchanged with an operating mechanism, our problem is to determine the actual changes of a *thermal level* of the body and the changes of its *thermal load*, — though in arbitrary units.

Such a cyclic change of state of a body of gas or vapor affords a simple example. The cycle must be considered to be executed reversibly, in order that the direction of operation can be reversed by retracing the paths of change of state of the body. In the operation it will be required to expand or compress the gas or vapor at constant temperature, and to expand or compress it when thermally insulated. The process at constant temperature is *isothermal*. When transfer of heat to or from the body is prevented, the process is *adiabatic*. Adiabatic changes of state may be reversible or not.

Fig. 6 exhibits a portion of the fluid field of Fig. 1. Let the body in question be supposed confined in a cylinder by a fric-

tionless piston, and let the point c in the vapor field represent its initial state. In reversible isothermal expansion from c to d

in this field the vapor develops work, and it absorbs heat in order that its temperature may not fall. Then in reversible adiabatic expansion from d to e work is developed, and the temperature falls from t_2 to t_1 since energy is lost and no heat is absorbed. Next, in reversible isothermal compression at t_1 work is absorbed, and heat is developed in order that the temperature may not rise. This

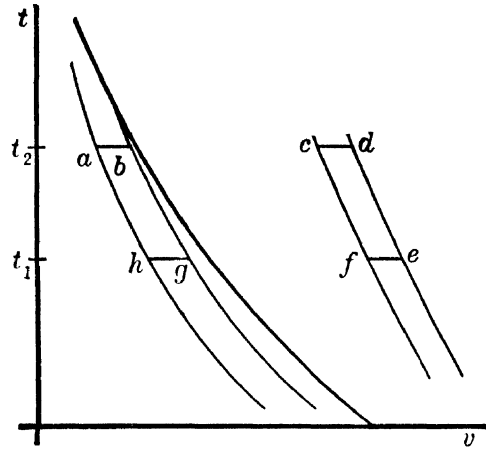

FIG. 7 a

compression is discontinued at a point f , from which reversible adiabatic compression restores the vapor to its initial state c , with a rise of temperature and a final absorption of work.

Three contrasting graphical representations of this cyclic process are afforded by the projections of the cyclic path on the three coordinate planes, as is shown in Figs. 7 a, 7 b, and 7 c.

The positive net quantity of work W developed by the vapor is represented by the area of the figure $cdef$ in the v, p plane of Fig. 7 b. If Q is the quantity of heat absorbed in the isothermal expansion at t_2 , and if x is that developed in the isothermal compression at t_1 , the relation connecting the quantities W, x, Q is given by the energy law. The energy of the body of vapor has regained its initial value,

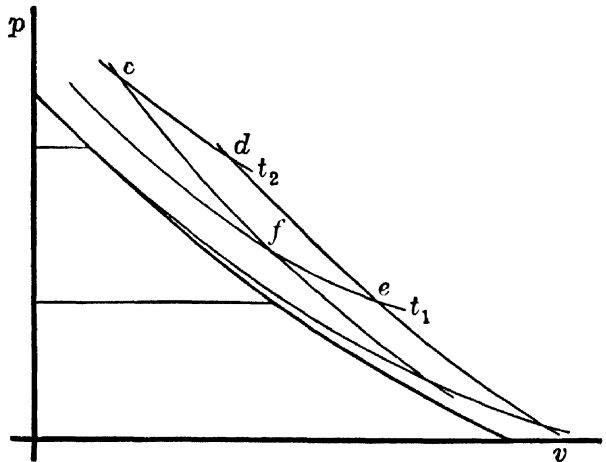

FIG. 7 b

The energy of the body of vapor has regained its initial value,

since this body is restored to its initial state. Hence the change of the energy is zero; and it is equal to the sum of the work $-W$ and the heat $Q - x$ absorbed in the process,

$$0 = -W + Q - x.$$

When this equation is written in the form

$$Q = W + x,$$

it asserts that the quantity of heat Q absorbed at the higher temperature t_2 is converted in part into the work W developed, and in part into the heat x developed at the lower temperature t_1 . This relationship is neatly represented by the diagram of Fig. 8.

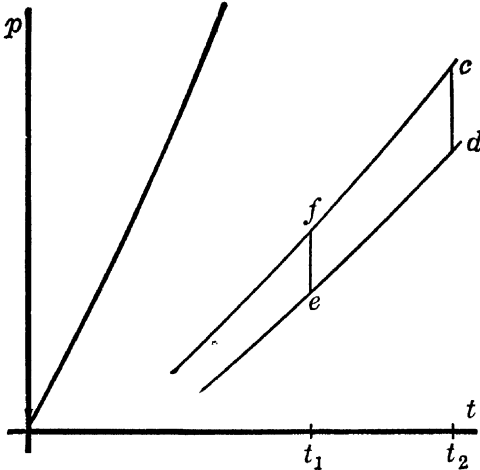

FIG. 7 c

The cyclic set of operations is an example of a *Carnot cycle*. A representation of the *reversed* set of operations, following the path *cfed*, or indeed beginning and ending at *any* point of the cyclic path, is obtained by reversing the directions of the arrows in the figure (see Fig. 9). In this case the heat x absorbed at the temperature t_1 , and the absorbed work W , are together transformed into the heat Q developed at the higher temperature.

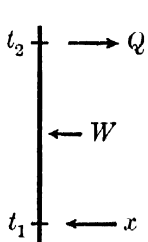

FIG. 9

Another example of a Carnot cycle is represented by the path *abgh* in Figs. 6 and 7 a. This path lies in the "evaporation field" of the body, where the states are states of interconvertible masses of liquid and vapor. In the reversible isothermal expansion *ab* evaporation occurs, with development of work and absorption of heat Q (heat of evaporation) at t_2 . In the reversible adiabatic expansion *bg* the temperature falls from t_2 to t_1 , and work is developed. The reversible isothermal compression *gh* absorbs work and develops heat x (equal to the heat of evaporation on the path *hg*) at t_1 . The final stage *ha*, which is a

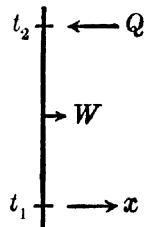

FIG. 8

reversible adiabatic expansion *bg* the temperature falls from t_2 to t_1 , and work is developed. The reversible isothermal compression *gh* absorbs work and develops heat x (equal to the heat of evaporation on the path *hg*) at t_1 . The final stage *ha*, which is a

process of adiabatic compression, restores the body to its initial state, with a final absorption of work.

Here again the positive net quantity W of work developed by the body is represented by the area of the figure $abgh$ when projected on the v, p plane. This figure is not shown in Fig. 7 *b*. And, as before, the change of the energy of the body is zero and is equal to the sum of the work $-W$ and the heat $Q - x$ absorbed in the process,

$$0 = -W + Q - x.$$

Hence the operation of this Carnot cycle and that of the reversed cycle are represented by the diagrams previously used (see Fig. 10).

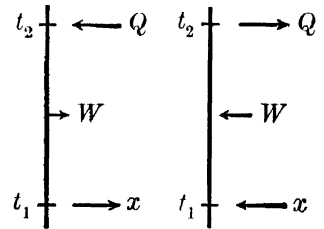

FIG. 10

It is not necessary that the isothermal paths, or even the adiabatic paths, of a Carnot cycle should lie within the same region of states. They may cross the regional boundaries in any possible way. An illustrative example is the cycle $bcfg$ in the foregoing Figs. 6 and 7 *a*. The essential features are stated in the definition:

Definition. Any reversible cyclic thermodynamic process conducted on an isothermal path followed successively by an adiabatic, an isothermal, and a concluding adiabatic path, is a Carnot cycle.

It should be observed that the first diagram of Fig. 10 equally well represents the changes of state of an elevator car absorbing potential energy Q with a load-increment at a height t_2 , developing potential energy x with the discharged load at a height t_1 , less than t_2 , and being returned to its initial position, whereby the car develops a net quantity of work W . Similarly the second diagram represents the reversed operation of this cyclic process.

It is important to remark that any isothermal transfer of heat can be utilized as one of the isothermal stages of the operation of a Carnot cycle. Even an isothermal transfer that does not alter the volume of the working body can be so utilized. To illustrate this, let the isothermal process be an isometric (occurring at constant volume) absorption of a quantity of heat by a body composed of coexistent masses of liquid water, ice, and water vapor at the freezing temperature t_2 of water under its

vapor pressure. The states of equilibrium of this body are determined by its volume V and energy E . In the V, E plane of Fig. 11 these states are represented by the points of a triangle, the apexes of which represent the states of the body when wholly solid, or liquid, or vapor respectively at the temperature t_2 . Paths in the triangle are isothermal. The absorption of a quantity of heat Q on the isometric path from 1 to 2 involves fusion of some of the ice and a slight increase of the mass of the vapor, since the volume of the liquid formed is less than that of the ice melted. Next, on the adiabatic expansion from 2 to a , the

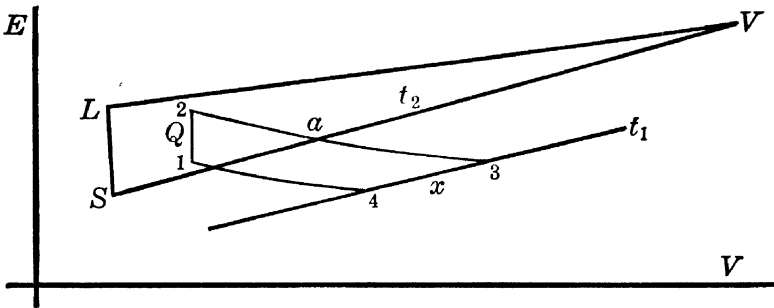

FIG. 11

working body is converted into coexistent masses of ice and vapor, without change of temperature; and on the further adiabatic expansion from a to 3 it is brought to a temperature t_1 , less than t_2 . In isothermal compression from 3 to 4 at this temperature, until the path of compression meets the adiabatic path containing the initial state, a portion of the vapor condenses (solidifies) with development of a quantity of heat x (heat of sublimation). The adiabatic compression from 4 to 1 concluding the cycle raises the temperature of the body until liquefaction begins at t_2 , and then adiabatically and isothermally restores the body to its initial state. In the whole cyclical operation the working body absorbs heat Q at the temperature t_2 , develops heat x at the temperature t_1 , and develops a quantity of work W . The process is represented by the first diagram of Fig. 10.

Varieties of Carnot Cycles. It must not be supposed that all Carnot cycles are operated under the action of an imposed

pressure. The work-transfers involved may be the effect of other forces, even non-mechanical ones. And, even when a Carnot cycle is operated under the action of a uniform and normally directed pressure, its characteristics may differ markedly from those of the cycles cited for illustration in the foregoing. When the thermodynamic properties of liquid water are examined, it appears that it is possible to devise Carnot cycles in which expansion of this fluid occurs on *both* isotherms, or compression on *both* adiabatics, or both of these things together; and that it is possible to devise Carnot cycles in which isothermal expansion *develops* heat, or in which adiabatic expansion *increases* the temperature, or in which the heat transferred at each temperature and the total work developed are all equal to zero. The most familiar type of cycle is not by any means the only possible type.

The Case $t_2 = t_1$. If a Carnot cycle absorbs heat x at a temperature t_1 , operates between temperatures t_1 and t_2 , and develops heat Q at t_2 , we may have that t_2 is either greater than, equal to, or less than t_1 . Attention should be directed to the various types of cycle that are realizable in the transition case in which $t_2 = t_1$. It may be that the adiabatic paths vanish while the second isothermal path becomes a reversal of the first, or while an isothermal change of state is conducted forward on one path and back on another. Or it may be that distinct isotherms are connected by adiabatic paths in an isothermal region, or that distinct isotherms are connected by non-isothermal adiabatics.

The first possibility cited, in which a cycle consists of an isothermal process conducted forward and back on the same path, can be realized by reversing the path of any isothermal reversible change of state.

An example of an isothermal process conducted forward on one path and back on another is afforded by the isothermal dilution of a solution of cane sugar by a body of water. The process can be conducted by reversible evaporation of the water, expansion of the resulting vapor from the vapor pressure of water to the (lower) vapor pressure of the solution, and condensation of the vapor upon the solution. The isothermal dilution so effected

can be reversed in consequence of the fact that water and the solution can be separated by a piston permeable only by the water. When so separated, the tendency of the liquids to mix can be counterbalanced by a force applied to the piston. On infinitesimally increasing this force a reversible isothermal separation of water from the solution is effected.

The third possibility, that distinct isotherms are connected by finite isothermal adiabatics, is realized in certain isothermal regions of states of equilibrium.

The field of states of coexistent liquid water, ice, and water vapor is such a region. In Fig. 12 let 14 and 23 be any two adiabatic paths in the region as represented in the volume-energy plane. Since any path is an isotherm, the cycle

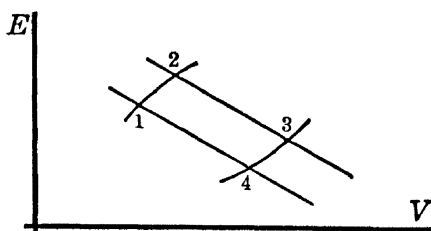

FIG. 12

1234 is a Carnot cycle in which the temperatures of the isotherms 12 and 34 are equal. Since the pressure is constant throughout the region, the work developed in the operation of the cycle is equal to zero. Hence the heat absorbed on the isotherm 12 is equal to that developed on the isotherm 34.

The last possibility cited, of Carnot cycles in which distinct isotherms are connected by non-isothermal adiabatics, can be realized when water is employed as a working fluid.

Sequences. Some Carnot cycles, especially when the working body is a gas, can be operated over wide ranges of temperature. Others cannot. For example, reversible adiabatic compression of a solid body cannot be extended beyond the limit of elasticity of the body. If a given elastic solid develops a quantity of heat Q_2 in reversible compression at the constant temperature $t_2 = 20^\circ \text{C}$, and it is desired to connect this development, by means of a Carnot cycle, with a corresponding reversible absorption of heat at the temperature $t_0 = 0^\circ \text{C}$, chosen as a temperature of reference, it will in general be impossible to do so. If, however, beginning with the given compression, we complete a Carnot cycle operating between t_2 and a slightly different temperature $t_1 = t_2 - \delta t_2$ or $t_2 + \delta t_2$, at which temperature heat

Q_1 is absorbed, we can couple this cycle with an auxiliary Carnot cycle operating between t_1 and t_0 and in which some working body of gas develops heat Q_1 at t_1 and absorbs a quantity of heat Q_0 at t_0 . The operation of the set of two cycles is represented by the corresponding diagram of Fig. 13. For the

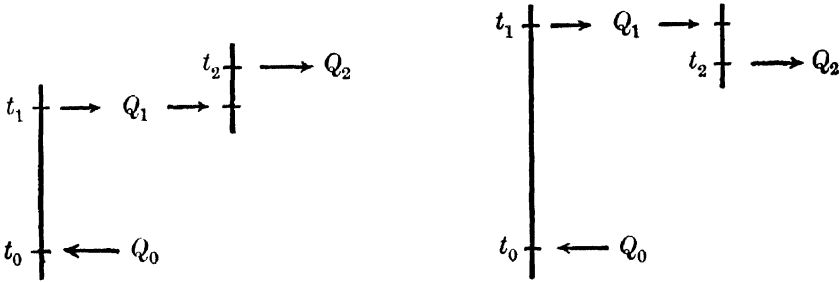

FIG. 13

present we leave open the questions whether the value of Q_0 depends upon the choice of the auxiliary gas, and of the cycle that it traverses.

We are thus led to consider the idea of a set of Carnot cycles operating through successive temperature intervals and executed by any possible working bodies.

In the operation of such a set, as represented by Fig. 14, some working body absorbs heat x at t_1 and transfers heat y_1 at t_2 to a second working body, which in turn transfers heat y_2 at t_4 to a third body, which develops heat Q at the final temperature t_3

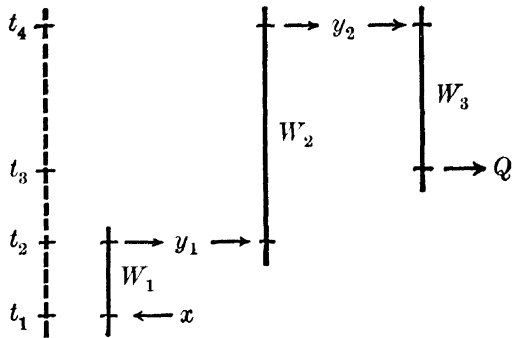

FIG. 14

reached by the set. We may even permit two successive cycles to be executed by the same working body, which first transfers heat to an extraneous body at the temperature of transfer, whereupon this heat is reabsorbed at the same temperature in the preliminary stage of the succeeding cycle. Since each working body is restored to its initial state, the outstanding changes of state effected in the operation of the set consist of an isothermal development of heat x by some body B_1 at

the temperature t_1 , an isothermal absorption of heat by a body B_3 at the temperature t_3 , and a development of work by a mechanism under the control of which the operations may be supposed to have been conducted. Any set of cycles such as this shall be termed a sequence of Carnot cycles, or briefly a *sequence*. More definitely, let the i th cycle of a set of Carnot cycles absorb heat x_i at a temperature t_{i1} , operate between temperatures t_{i1} and t_{i2} , and develop heat Q_i at t_{i2} , where $i = 1, 2, \dots, n$. Then:

Definition. When $n = 1$, and when $n > 1$ and the conditions

$$t_{i1} = t_{i-1, 2}, \quad x_i = Q_{i-1}, \quad i = 2, 3, \dots, n,$$

are satisfied, the set of Carnot cycles shall be termed a sequence.

When a sequence operates between the terminal temperatures t_1 and t_2 , and one of the terminal working bodies absorbs the heat x at t_1 while the other develops the heat Q at t_2 , and W is the total work absorbed in the operation of all the cycles

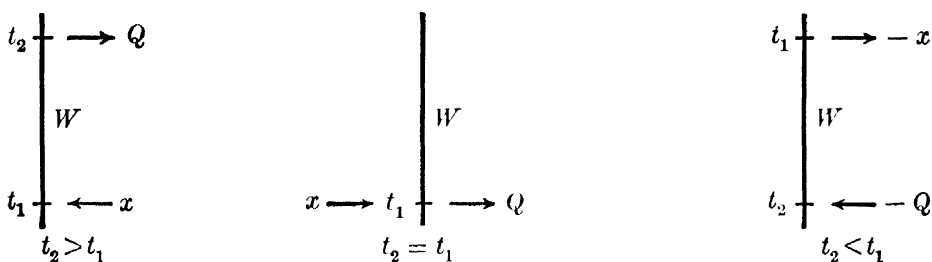

FIG. 15

of the sequence, then the quantities x, Q, W shall be termed the heat absorbed at t_1 , the heat developed at t_2 , and the work absorbed, *by the sequence*.

In the operation of a sequence, x may be positive, zero, or negative, and t_2 may be greater than, equal to, or less than t_1 , as indicated in Fig. 15. If we use the notation y_i employed in Fig. 14, and apply the energy law to the change of state of the working body of each cycle, we obtain the equations

$$\begin{aligned} x + W_1 &= y_1 \\ y_1 + W_2 &= y_2 \\ &\dots \\ y_{n-1} + W_n &= Q. \end{aligned}$$

On adding these equations, and noting that the work absorbed by the sequence is $W = W_1 + W_2 + \cdots + W_n$, we find in all cases that

$$x + W = Q. \quad (5)$$

Synopsis. When a body whose volume is V is compressed or expanded along a slowly traversed path under the action of a uniform and normally directed pressure p , the work absorbed by the body is a line integral of the inexact expression $-pdV$.

When a continuous one-dimensional set* of states of thermodynamic equilibrium connecting states a and b of a body is the limit approached by a family of paths of the change of state ab , and also by a family of paths of the reversed change of state ba , when these changes of state are conducted with extreme slowness under the influence of the independently controlled imposed forces and temperature, the set is termed a *reversible path* of either change of state. And the limits of the quantities of work and heat absorbed on the paths of the change ab , which are equal to the negatives of the limits of the work and heat absorbed on the paths of the change ba , as the limiting path is approached, are termed the work and heat absorbed *on the reversible path ab* , or developed *on the reversible path ba* . Apparently a continuous one-dimensional set of states of equilibrium is not necessarily a reversible path.

Any reversible cyclic thermodynamic process conducted on an isothermal path followed successively by an adiabatic, an isothermal, and a concluding adiabatic path, is a *Carnot cycle*. Any reversible isothermal transfer of heat can be utilized as one of the isothermal stages of such a cycle. When a Carnot cycle operates between temperatures t_1 and t_2 , the transition case in which $t_2 = t_1$ may be realized in various ways. It may be that the adiabatic paths vanish while the second isothermal path becomes a reversal of the first, or while an isothermal change of state is conducted forward on one path and back on another. Or it may be that distinct isotherms are connected by adia-

* A set is continuous and one-dimensional when its elements, while their order is preserved, can be put into continuous one-to-one correspondence with the points of a straight line segment, or (in the case of a cyclic set) with the points of a circle.

batic paths in an isothermal region, or that distinct isotherms are connected by non-isothermal adiabatics.

Let the i th cycle of a set of Carnot cycles absorb heat x_i at a temperature $t_{i,1}$, operate between temperatures $t_{i,1}$ and $t_{i,2}$, and develop heat Q_i at $t_{i,2}$, where $i = 1, 2, \dots, n$. When $n = 1$, and when $n > 1$ and the conditions

$$t_{i,1} = t_{i-1,2}, \quad x_i = Q_{i-1}, \quad i = 2, 3, \dots, n,$$

are satisfied, the set of cycles is a *sequence*.

When a sequence operates between the terminal temperatures t_1 and t_2 , and one of the terminal working bodies absorbs heat x at t_1 while the other develops heat Q at t_2 , and W is the total work absorbed in the operation of all the cycles of the sequence, then the quantities x, Q, W are termed the heat absorbed at t_1 , the heat developed at t_2 , and the work absorbed, *by the sequence*. In all cases these quantities are connected by the relation

$$x + W = Q.$$

CHAPTER IV

THE SECOND LAW OF THERMODYNAMICS

In order to transform potential energy into work, through the operation of a freight elevator, we must utilize at least two different heights. No elevator that does not descend to the zero height from which the potential energy of its car is reckoned will absorb potential energy at a given height and transform it completely into work. A part of the absorbed energy must be developed at a lesser height with the discharged load. Similarly, in order to transform heat into work, through the operation of a heat engine, we must utilize at least two different temperatures. No engine will absorb heat at a given temperature and transform it completely into work. A part of the absorbed heat must be developed at the lower temperature of the condenser.

Although a quantity of work, through expenditure against friction, can be completely transformed into heat, it does not appear that a quantity of heat, whether supplied at constant temperature or obtained from the uniform cooling of a body, can be completely transformed into work. If a mere cooling could supplement an absorption of work, it should be possible to devise an apparatus that would enable us to drive our factories and trains at the expense of a cooling of the atmosphere, or to construct a motor that should drive a ship at the expense of a cooling of the sea. Since such possibilities cannot be seriously entertained, we are led to postulate as a general principle that

A change of state consisting of a development of heat cannot supplement a change of state consisting of an absorption of work.

This principle is termed the *second law of thermodynamics*. Further to illustrate its significance, consider a hot metal rod, fixed at one end and attached to a spring at the other. On cooling, the rod shortens and develops work in straining the spring.

Yet the cooling does not supplement the absorption of work. It supplements this *together with* the change of state of the surrounding air, to which heat is transferred. Again, consider an isothermal expansion of a mass of an "ideal gas." In this very approximately realizable process, the heat absorbed is equal to the work developed. Apparently the heat is converted into work. Yet the heat-development utilized does not supplement the work-absorption. It supplements this *together with* the outstanding change of state of the expanded gas.

In addition to the above principle, the second law of thermodynamics is considered to include the postulate that

An unsupplemented transfer of heat from a cooler body to a warmer one is impossible.

A very useful particular case of the second law is the postulate that an *isothermal* development of heat cannot supplement an absorption of work.

CHAPTER V

A THEOREM ON SEQUENCES

Let any sequence operate between the arbitrary temperatures t_1 and t_2 , as recorded on an *arbitrary* scale of temperatures, *absorb* x units of heat at t_1 , *absorb* a net amount of W units of work, and *develop* Q units of heat at t_2 , the quantities x, W, Q being expressed in the same physical unit. When $t_2 > t_1$, and the sequence is so operated that x is positive, which is always possible when $x \neq 0$, we have by (5) that $Q = x + W$, and hence that $Q > W$. There are five conceivable cases :

- | | | | | |
|-----|----------|----------|----|--------------|
| (a) | $Q > 0,$ | $W > 0,$ | so | $0 < W < Q;$ |
| (b) | $Q > 0,$ | $W = 0,$ | so | $0 = W < Q;$ |
| (c) | $Q > 0,$ | $W < 0,$ | so | $W < 0 < Q;$ |
| (d) | $Q = 0,$ | $W < 0,$ | so | $W < 0 = Q;$ |
| (e) | $Q < 0,$ | $W < 0,$ | so | $W < Q < 0.$ |

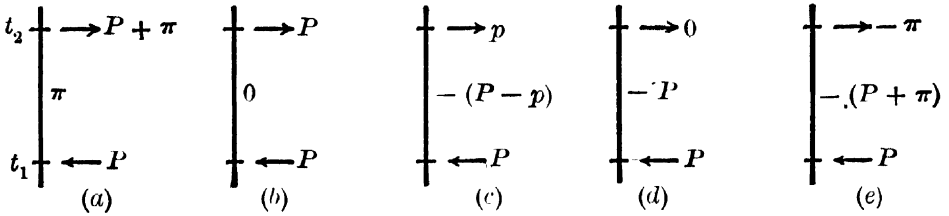

FIG. 16

If the symbols P, p, π represent positive quantities, where $P > p$, and if $x = P$, these successive cases are represented by the successive diagrams of Fig. 16, which are obtained as follows :

- (a) $W = \pi$; $Q = x + W = P + \pi$, which is greater than W .
 (b) $W = 0$; $Q = x + W = P$, which is greater than W .
 (c) $W = Q - x < 0$, hence $0 < Q < x$, so $Q = p$;
 $W = Q - x = p - P.$
 (d) $Q = 0$; $W = Q - x = -P$.
 (e) $Q = -\pi$; $W = Q - x = -\pi - P$, which is less than Q .

These successive sets of values are displayed in Fig. 17 by the graph of the function $W = Q - P$, plotted against decreasing values of Q . The ordinates indicated by dash lines are placed arbitrarily within the intervals in which they occur.

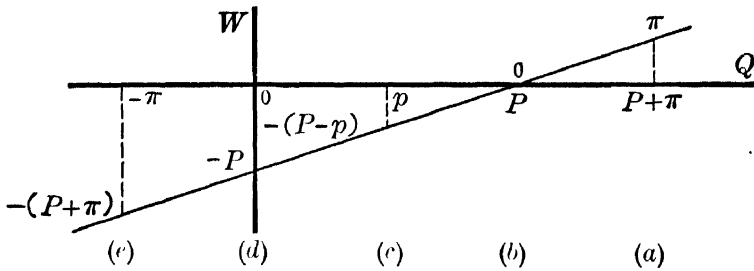

FIG. 17

In each of the five cases, let B_1, B_2 be the outside bodies exchanging heat with the sequence at the respective temperatures t_1, t_2 .

The case (a) is the familiar one in which the sequence absorbs positive heat P at t_1 , absorbs positive work π , and develops both as heat at t_2 .

In the case (b) the result of the operation of the sequence is that B_1 develops heat P at t_1 , while B_2 absorbs this heat at the higher temperature t_2 . Since this unsupplemented transfer of heat from a cooler body to a warmer one violates the second law of thermodynamics, the possibility of case (b) must be denied.

When the operation of the sequence in the case (c) is concluded, let B_2 be held in contact with B_1 until the heat p shall have passed by conduction from B_2 to B_1 . This restores B_2 to its initial state, thus leaving outstanding only an absorption of work $P - p$ by a mechanism, and a supplementary net development of heat $P - p$ by B_1 at the constant temperature t_1 . Since this result violates the second law, the possibility of case (c) must be denied.

In the case (d) the result of the operation is an absorption of work P by a mechanism, and a supplementary development of heat P by B_1 at the constant temperature t_1 . Since the second law is violated, the possibility of case (d) must be denied.

When the operation in the case (e) is concluded, let the mechanism expend work π against friction and thereby transfer heat π to B_2 at the temperature t_2 .* This restores B_2 to its initial state, thus leaving outstanding a net absorption of work P by the mechanism, and a supplementary development of heat P by B_1 at the constant temperature t_1 . Since this result violates the second law, the possibility of case (e) must be denied.

It is thus established that the case (a) is the only possibility. Hence, with reference to the notation according to which any sequence operates between temperatures t_1 and t_2 , absorbs heat x at t_1 , absorbs work W , and develops heat Q at t_2 , we have proved that, when $x \neq 0$ and $t_2 > t_1$, the quantities x, W, Q have the same sign.

Let us now consider sequences for which $x = 0$, while t_2 is either greater than, equal to, or less than t_1 .

If $x = 0$ and $t_2 > t_1$, then by $x + W = Q$ we have $Q = W$. Hence the operation of the sequence is represented by Fig. 18. Obviously the second law is violated if W is negative, or if W is positive and the operation of the sequence is reversed. Hence $W = 0$.

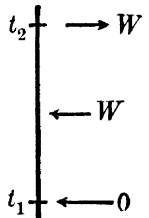

FIG. 18

If $x = 0$ and $t_2 < t_1$, then again $Q = W$. Hence the operation of the sequence is represented by Fig. 19 a, or in better

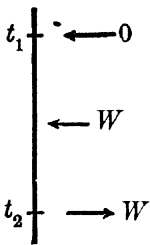

FIG. 19 a

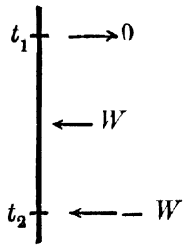

FIG. 19 b

arrangement by Fig. 19 b. Again the second law is violated if W is negative, or if W is positive and the operation of the sequence is reversed. Hence again $W = 0$.

* As if the mechanism were to expend π units of work in driving a paddle immersed in a relatively large body B_2 of water having the uniform temperature t_2 .

If $x = 0$ and $t_2 = t_1$, then again $Q = W$. Hence the operation of the sequence is represented by Fig. 20, and we conclude that $W = 0$, by the same reasoning as before.

It is thus established that W , and therefore Q , vanishes whenever $x = 0$. This conclusion and the preceding result are together expressed by the following theorem.*

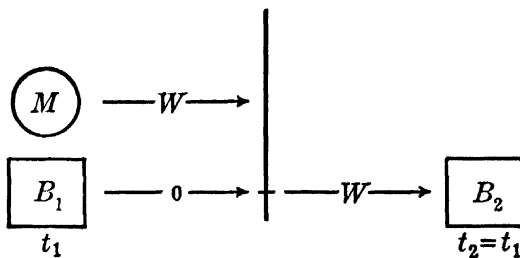

FIG. 20

Theorem I. *When $x \neq 0$ and $t_2 > t_1$, the quantities x, W, Q have the same sign; and when $x = 0$ these quantities all vanish, irrespective of whether t_2 is greater than, equal to, or less than t_1 .*

* It is not necessary to consider here the cases in which $x \neq 0$ and $t_2 < t_1$ or $t_2 = t_1$. It is easily seen that, in the first case, x, Q have the same sign while W has the contrary one; and that, in the second case, x, Q have the same sign while $W = 0$.

Exclusion of the foregoing case (b) is the sole purpose of the distinct postulate that an unsupplemented transfer of heat from a cooler body to a warmer one is impossible. Now, if the case (b) were possible within a temperature range $t_\alpha \leqq t \leqq t_\beta$, it would follow, from the postulate that a development of heat cannot supplement an absorption of work, that no other case is possible within the range. For a sequence of the type (a), if its operation were reversed, could be coupled with a sequence of the type (b) in such a manner that (a) would transfer work π to a mechanism M , and heat P to (b), while (b) would transfer heat P to an outside body B_2 at the constant temperature t_2 , and B_2 would transfer heat $P + \pi$ to (a). The net result would be an absorption of work by M , supplemented by an equal isothermal development of heat by B_2 , in conflict with the postulate just cited. So it would follow that π could not differ from zero when t_1, t_2 lay within the range $t_\alpha \leqq t \leqq t_\beta$.

CHAPTER VI

THE WORK ABSORBED BY A SEQUENCE

W is Independent of the Working Bodies. When W is the number of units of work absorbed by a sequence that absorbs x units of heat at a temperature t_1 and operates between temperatures t_1 and t_2 , we desire to know how W depends on x , on t_1 and t_2 , on the working bodies employed in the operation of the sequence, and on the particular cycle traversed by each working body. To investigate the dependence of W on the working bodies, let us consider any two such sequences. We shall require to examine the cases in which x is either positive, or zero, or negative, and in which, under each of these conditions, t_2 is either greater than, or equal to, or less than t_1 .

CASE 1. $x \neq 0$ and $t_2 > t_1$

Let w and W be the quantities of work absorbed by any two sequences, each of which absorbs a positive or negative quantity of heat x at t_1 and operates between t_1 and t_2 , where $t_2 > t_1$. And let the sequences be so operated that x is positive. (See Fig. 21.) Since x is positive it follows, by Theorem I, that w and W are positive. If w and W are not equal, let W be the greater. On reversing the operation of the sequence absorbing W , the sequences can be coupled in the manner

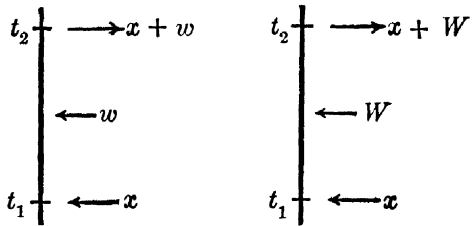

FIG. 21

indicated in Fig. 22. Hereupon in the operation of the couple an outside body B_2 develops heat $x + W$ at the temperature t_2 , work W is absorbed by the controlling mechanism M , heat x is developed by one sequence and absorbed by the other, work w is developed by the mechanism, and heat $x + w$ is absorbed by the body B_2 at its temperature t_2 . Since the working bodies

that traverse the cycles of the sequences are restored to their initial states, the outstanding changes of state are an absorption of the positive work $W - w$ by the mechanism, and a supplementary development of the equal quantity of heat $(x + W) - (x + w)$

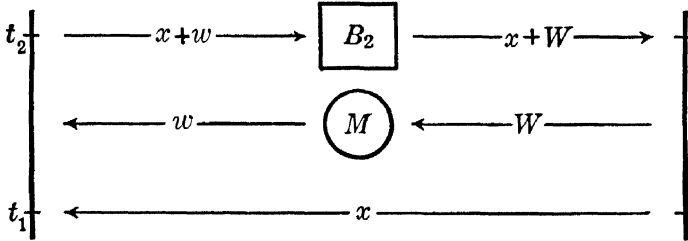

FIG. 22

by B_2 at the constant temperature t_2 . This result violates the second law, that an isothermal development of heat cannot supplement an absorption of work. Hence W cannot be greater than w . We thus observe that all sequences absorbing equal positive or negative quantities of heat at any temperature t_1 , and operating between t_1 and a higher temperature t_2 , absorb equal quantities of work.

CASE 2. $x \neq 0$ and $t_2 < t_1$

Let w and W be the quantities of work absorbed by any two sequences, each of which absorbs a positive or negative quantity of heat x at t_1 and operates

between t_1 and t_2 , where $t_2 < t_1$. And let the sequences be so operated that x is positive. (See Fig. 23.) Since x is positive it follows, by Theorem I, that w and W are negative.* If the positive quantities $-w$ and $-W$ are not equal, let $-w$ be the greater.

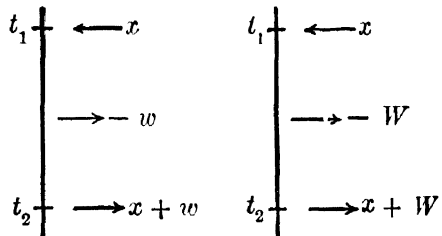

FIG. 23

On reversing the sequence absorbing W , the operation of the

* For, on reversing the operation of the first sequence, the quantities

$$-(x + w), \quad + w, \quad - x,$$

have the same sign, which is negative since it is that of $-x$. The same reasoning applies to the operation of the second sequence.

coupled sequences is that represented by Fig. 24. In this case the mechanism M gains the positive work $(-w) - (-W)$ at the expense of an equal isothermal development of heat $W - w$

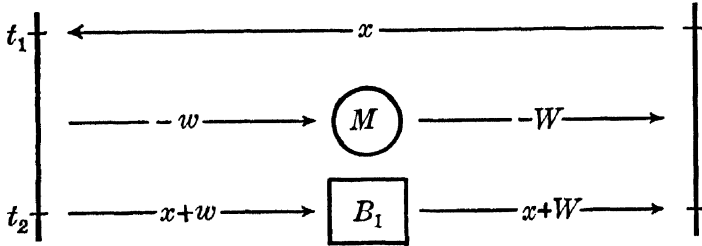

FIG. 24

by B_1 . This result violates the second law. Hence W is equal to w . All sequences absorbing equal positive or negative quantities of heat at any temperature t_1 , and operating between t_1 and a lower temperature t_2 , absorb equal quantities of work.

CASE 3. $x \neq 0$ and $t_2 = t_1$

A sequence absorbing a positive or negative quantity of heat x at t_1 , and operating between t_1 and t_2 , where $t_2 = t_1$, may be a sequence of one term or of more than one term. When it consists of but one term, it may be that the adiabatic paths of the cycle vanish while the second isothermal path becomes a reversal of the first, or while an isothermal change of state is conducted forward on one path and back on another. Or it may be that distinct isotherms are connected

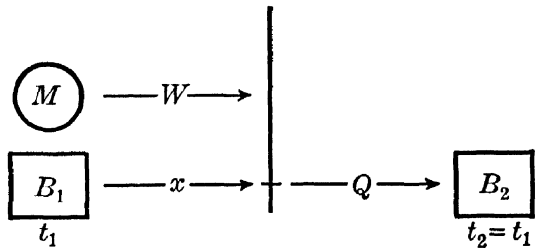

FIG. 25

by either isothermal or non-isothermal adiabatics. In any case the outstanding changes of state are, at most, a development of heat x by a body B_1 , a development of work W by a mechanism M , and an absorption of heat Q by a body B_2 , as is indicated by Fig. 25.

Assuming the existence of such a cycle, for which $W \neq 0$, let us suppose the cycle so operated that W is negative. Then an

absorption of positive work $-W$ by a mechanism would be supplemented by an equal isothermal development of heat $x - Q$, in violation of the second law.* Hence W cannot differ from zero. When the isothermal paths of a sequence are traversed at the same temperature, and a positive or negative quantity of heat is absorbed on either of them, the work absorbed in the operation of the sequence is equal to zero.

CASE 4. $x = 0$

By Theorem I we have that the work W absorbed by a sequence absorbing heat $x = 0$ at t_1 and operating between t_1 and t_2 is equal to zero, irrespective of whether t_2 is greater than, equal to, or less than t_1 . So, in this case as in the preceding ones, W is independent of the nature of the working bodies employed in the operation of the sequence.

The Function W . From the foregoing discussion it appears that the work W absorbed by a sequence absorbing heat x at a temperature t_1 and operating between temperatures t_1 and t_2 is independent of the nature of the working bodies employed in the operation of the sequence, irrespective of whether x is positive, zero, or negative, and whether t_2 is greater than, equal to, or less than t_1 . It appears that W depends only on x , t_1 , and t_2 , and that it always has the same value for a given set of values of these variables. It is established, namely, that W is a single-valued function $W(x, t_1, t_2)$ of the independent real variables x, t_1, t_2 . Further, since it is physically obvious that, for all sets of values of x, t_1, t_2 , sufficiently small changes of these variables effect arbitrarily small changes of W , we are justified in considering the function W to be continuous. So the *physical* reasoning employed in studying the operation of any sequence yields the *mathematical* statement:

Theorem II. *The work W absorbed by any sequence absorbing heat x at a temperature t_1 and operating between temperatures t_1 and t_2 is a single-valued continuous function $W(x, t_1, t_2)$ of the independent real variables x, t_1, t_2 . And $W(x, t_1, t_2) = 0$ for $t_2 = t_1$.*

*From $x + W = Q$ it follows that the heat $x - Q$ developed by the body B_1B_2 is $x - Q = -W > 0$.

It is important to notice that, in the notation here employed, the symbol $W(x, t_2, t_1)$ denotes the work absorbed by a sequence absorbing heat x at the temperature t_2 and operating between t_2 and t_1 .

Synopsis of Chapters IV, V, VI. The postulates, that a change of state consisting of a development of heat cannot supplement a change of state consisting of an absorption of work, and that an unsupplemented transfer of heat from a cooler body to a warmer one is impossible, constitute the *second law of thermodynamics*.

Let any sequence absorb heat x at a temperature t_1 , operate between temperatures t_1 and t_2 , absorb work W , and develop heat Q at t_2 . Stated in terms of this notation, it follows from the laws of thermodynamics that when $x \neq 0$ and $t_2 > t_1$ the quantities x, W, Q have the same sign, and that when $x = 0$ these quantities all vanish, irrespective of whether t_2 is greater than, equal to, or less than t_1 .

It also follows that the work W is independent of the working bodies employed in the operation of the sequence, and that it always has the same value for a given set of values of x, t_1, t_2 . Hence, when we assume it to be physically obvious that W is a *continuous* function of these variables, we have the theorem :

The work W is a single-valued continuous function $W(x, t_1, t_2)$ of the independent real variables x, t_1, t_2 . And $W(x, t_1, t_2) = 0$ for $t_2 = t_1$.

CHAPTER VII

THE FORM OF THE FUNCTION $W(x, t_1, t_2)$ IN x

Dependence of W upon x . We may now seek the form of dependence of W upon x . Any two sequences absorbing the respective arbitrary quantities of heat x and ξ at t_1 , and operating between t_1 and t_2 , are together equivalent to a sequence absorbing the heat $x + \xi$ at t_1 and operating between the same temperatures. In symbols,

$$W(x, t_1, t_2) + W(\xi, t_1, t_2) = W(x + \xi, t_1, t_2), \quad (6)$$

where ξ is an arbitrary constant.

For the present purpose it is convenient to simplify the deduction of the solution of the well-known functional equation

$$W(x) + W(\xi) = W(x + \xi),$$

by introducing the assumption, which is physically unobjectionable, that $W(x, t_1, t_2)$ possesses a derivative $\partial W/\partial x$. Then, differentiating (6), and writing W' for $\partial W/\partial x$,

$$W'(x) = W'(x + \xi).$$

It thus appears that W' , when x has any value, is equal to W' when x has any other value. That is, it appears that

$$W' = a,$$

where a is independent of x . Integrating,

$$W = ax + b,$$

where b is independent of x . Substituting this expression in (6),

$$(ax + b) + (a\xi + b) = a(x + \xi) + b,$$

which reduces to $b = 0$. Hence,

$$W = ax,$$

wherefore $a = W(1)$. We thus find that the form of dependence of W on x is expressed by the identity

$$W(x, t_1, t_2) = W(1, t_1, t_2)x. \quad (7)$$

On eliminating W between (7) and (5), which is

$$x + W(x, t_1, t_2) = Q,$$

we obtain

$$Q = [1 + W(1, t_1, t_2)]x. \quad (8)$$

By Theorem II and the equations (7) and (8), the ratios W/x and Q/x are single-valued continuous functions of t_1, t_2 . This statement involves the *Theorem of Carnot*, that the "efficiency"

$$\frac{W}{Q} = \frac{W(1, t_1, t_2)}{1 + W(1, t_1, t_2)}$$

of a Carnot cycle is independent of the nature of the working body and is a function solely of the temperatures between which the cycle operates.

Synopsis. Any two sequences absorbing the respective arbitrary quantities of heat x and ξ at t_1 , and operating between t_1 and t_2 , are together equivalent to a sequence absorbing heat $x + \xi$ at t_1 and operating between t_1 and t_2 ,

$$W(x, t_1, t_2) + W(\xi, t_1, t_2) = W(x + \xi, t_1, t_2).$$

It follows that the form of dependence of W on x is expressed by the identity

$$W(x, t_1, t_2) = W(1, t_1, t_2)x. \quad (7)$$

On eliminating W between this and

$$W(x, t_1, t_2) = Q - x,$$

we obtain

$$Q = [1 + W(1, t_1, t_2)]x. \quad (8)$$

By (7) and (8), the ratios W/x and Q/x are single-valued continuous functions of t_1, t_2 . This result includes the *Theorem of Carnot*, that the efficiency W/Q of a Carnot cycle is independent of the nature of the working body and is a function solely of the temperatures between which the cycle operates.

CHAPTER VIII

THE FORM OF THE FUNCTION $W(x, t_1, t_2)$ IN t_1, t_2

Dependence of W upon t_1, t_2 . Now that the form of dependence of the function $W(x, t_1, t_2)$ upon x has been determined, it remains to investigate the dependence of W on t_1 and t_2 . The dependence of W on x was studied by giving x an arbitrary increment ξ , which caused the function to receive an increment

$$W(x + \xi, t_1, t_2) - W(x, t_1, t_2);$$

whereupon formulation of this increment provided a functional equation

$$W(x + \xi, t_1, t_2) - W(x, t_1, t_2) = W(\xi, t_1, t_2),$$

the solution of which supplied the information sought. If we study the dependence of W on t_1 and t_2 in a similar way, by giving an arbitrary increment $t_3 - t_2$ to the temperature interval $t_2 - t_1$ through which the sequence operates, whereupon the function $W(x, t_1, t_2)$ receives an increment

$$W(x, t_1, t_3) - W(x, t_1, t_2),$$

we shall find that formulation of this increment provides a functional equation the solution of which supplies the information sought. Of course the *analytical form* of the first factor of the function $W(1, t_1, t_2)x$ will vary with the choice of the temperature scale with reference to which the values of t_1, t_2 are expressed.

Formulating the Increment of W . Consider any sequence absorbing heat 1 at t_1 and operated in an initial stage from t_1 to t_2 followed by a concluding stage from t_2 to t_3 , where t_1, t_2, t_3 are arbitrary. Since the heat absorbed at t_2 in the concluding stage is $1 + W(1, t_1, t_2)$, it follows that the work-absorption of this stage is $W(1, t_2, t_3)[1 + W(1, t_1, t_2)]$. Now the work-absorption

of the sequence is equal to the work-absorption $W(1, t_1, t_3)$ of any sequence absorbing heat 1 at t_1 and operating between t_1 and t_3 ,

$$W(1, t_1, t_3) = W(1, t_1, t_2) + W(1, t_2, t_3)[1 + W(1, t_1, t_2)]. \quad (9)$$

This is the functional equation wanted.

Theorems and Equations for Reference. Since parts of Theorems I and II, from pages 37 and 41, and equations (7) and (8), from page 44, will be employed in the discussion of (9), they are assembled here for convenience of reference.

I. When $x \neq 0$ and $t_2 > t_1$, the quantities x, W have the same sign.

II. The single-valued continuous function $W(x, t_1, t_2)$ is equal to zero for $t_2 = t_1$.

III. $W(x, t_1, t_2) = W(1, t_1, t_2)x$.

IV. $Q = [1 + W(1, t_1, t_2)]x$.

A Functional Equation for $q(t_1, t_2)$. On adding unity to each member of (9), and factoring the second member, we obtain

$$1 + W(1, t_1, t_3) = [1 + W(1, t_1, t_2)][1 + W(1, t_2, t_3)]. \quad (10)$$

This equation is in terms of the quantity $1 + W(1, t_i, t_j)$, which by (IV) is equal to the single-valued continuous function Q of x, t_i, t_j for $x = 1$. If we write $q(t_i, t_j)$ for the function $Q(1, t_i, t_j)$, we define q by the identity

$$q(t_i, t_j) = 1 + W(1, t_i, t_j); \quad (11)$$

whereupon the functional equation (10) becomes

$$q(t_1, t_3) = q(t_1, t_2)q(t_2, t_3), \quad (12)$$

which is a functional equation for q .

The Reciprocal of $q(t_1, t_2)$. By (II) we have $W(x, t_1, t_2) = 0$ for $t_2 = t_1$. For $x = 1, i = 1$, and $j = 2$, this converts (11) to

$$q(t_1, t_2) = 1, \quad t_2 = t_1. \quad (13)$$

If now in (12) we put $t_3 = t_1$, and make use of (13), we obtain

$$q(t_1, t_2)q(t_2, t_1) = 1. \quad (14)$$

Interpreted physically, $q(t_2, t_1)$ is the heat developed at t_1 by any sequence absorbing heat 1 at t_2 and operating between t_2 and t_1 .

If t_4 is any fourth constant, multiplication of each member of (12) by $q(t_3, t_4)$, reduction of the first member by (12), and writing q_{ij} for $q(t_i, t_j)$, give $q_{14} = q_{12}q_{23}q_{34}$. Since the process can be repeated indefinitely, we have $q_{1n} = q_{12}q_{23} \cdots q_{n-1, n}$, or by (14)

$$q_{12}q_{23} \cdots q_{n-1, n}q_n = 1,$$

where n is any positive integer.

The Sign of $q(t_1, t_2)$. By (14) and (11),

$$q(t_1, t_2) = \frac{1}{q(t_2, t_1)} = \frac{1}{1 + W(1, t_2, t_1)}.$$

When $t_2 < t_1$ we have by (I) that $W(1, t_2, t_1)$, having the sign of $x = 1$, is positive. Hence

$$t_2 < t_1, \quad 0 < q(t_1, t_2) < 1. \quad (15 a)$$

When $t_2 = t_1$ we have by (II) that $W(1, t_2, t_1) = 0$. Hence

$$t_2 = t_1, \quad q(t_1, t_2) = 1. \quad (15 b)$$

Finally, when $t_2 > t_1$ we have by (I) that $W(1, t_1, t_2)$ is positive. Hence $q(t_1, t_2) = W(1, t_1, t_2) + 1$ is greater than unity,

$$t_2 > t_1, \quad q(t_1, t_2) > 1. \quad (15 c)$$

From (12) and (15 c) it can easily be shown that $q(t_1, t_2)$ is a decreasing function of t_1 and an increasing function of t_2 . This information, however, is not required.

The Form of $q(t_1, t_2)$. Putting $t_2 = a$ in (12), where a is an arbitrary constant, and then putting $t_3 = t_2$,

$$q(t_1, t_2) = q(t_1, a)q(a, t_2),$$

or, by (14),

$$q(t_1, t_2) = \frac{q(a, t_2)}{q(a, t_1)}. \quad (16)$$

If we define a function $\theta(t)$ by

$$\theta = q(a, t), \quad (17)$$

the equation (16) becomes

$$q(t_1, t_2) = \frac{\theta(t_2)}{\theta(t_1)}. \quad (18)$$

By the equations (15), q is positive. Hence, by (17), θ is positive. Again, by (15 c), $q(t_1, t_2) > 1$ for $t_2 > t_1$, wherefore by (18)

$$\frac{\theta(t_2)}{\theta(t_1)} > 1, \quad t_2 > t_1.$$

Hence θ is an increasing function. Thus θ is a positive, increasing, single-valued, continuous function of t .

The Form of the Function $W(1, t_1, t_2)$. The form of the function W is now determined. By (III), (11), and (18), we have

$$W = W(1, t_1, t_2)x = [q(t_1, t_2) - 1]x = \left(\frac{\theta(t_2)}{\theta(t_1)} - 1\right)x.$$

So the form of W is expressed by the identity,

$$W(x, t_1, t_2) = \frac{\theta(t_2) - \theta(t_1)}{\theta(t_1)} x. \quad (19)$$

Since further, by (IV), $Q = [1 + W(1, t_1, t_2)]x$, it follows from (19) that the form of the single-valued continuous function $Q(x, t_1, t_2)$ is

$$Q = \frac{\theta(t_2)}{\theta(t_1)} x.$$

CHAPTER IX

THE ABSOLUTE TEMPERATURE

The Ratio Q/x . By (IV), (11), and (18) we have the successive equations

$$\frac{Q}{x} = 1 + W(1, t_1, t_2) = q(t_1, t_2) = \frac{\theta(t_2)}{\theta(t_1)}. \quad (20 a)$$

Let the constant t_r be the "ice point" (0° C or 32° F, etc.), and put $t_1 = t_r$ and $t_2 = t$. The equations become

$$\frac{Q}{x_r} = 1 + W(1, t_r, t) = q(t_r, t) = \frac{\theta(t)}{\theta(t_r)}, \quad (20 b)$$

where Q is any positive, zero, or negative quantity of heat reversibly developed by any body at the general temperature t , while x_r is the heat absorbed at t_r by any sequence operating between t_r and t and developing the heat Q at t .

Definition of the Absolute Temperature. Since the ratio Q/x_r is independent of the nature of the body developing the heat Q at the general temperature t , it is employed to define the ratio of an "absolute" temperature $\theta(t)$ to its arbitrary positive value $\theta(t_r)$ at the temperature of reference t_r . To fix the arbitrary constant $\theta(t_r)$, let the constant t_s be the "boiling point" (100° C or 212° F, etc.), assign Δ units (100 centigrade degrees or 180 Fahrenheit degrees, etc.) to the interval $\theta(t_s) - \theta(t_r)$, where Δ is a positive constant, $\theta(t_s) = \theta(t_r) + \Delta$,

and then equate the second and fourth members of (20 b) for $t = t_s$,

$$\frac{\theta(t_s)}{\theta(t_r)} = 1 + W(1, t_r, t_s).$$

On eliminating $\theta(t_s)$ between these two equations, and writing W_{rs} for $W(1, t_r, t_s)$, we obtain

$$\theta(t_r) = \frac{\Delta}{W_{rs}}, \quad (21)$$

where Δ/W_{rs} is a positive constant.

The last equation of (20 b),

$$\frac{\theta(t)}{\theta(t_r)} = q(t_r, t),$$

is reduced by (21) to

$$\theta = \frac{\Delta}{W_{rs}} \cdot q(t_r, t), \tag{22}$$

where indeed $q(t_r, t)$ may be replaced by $1 + W(1, t_r, t)$. In (22), the *absolute temperature* θ of any body having the uniform temperature t is defined by a positive, increasing, single-valued, continuous function of t .

Synopsis of Chapters VIII and IX. Since the form of dependence of $W(x, t_1, t_2)$ on x is now known, it remains to investigate the dependence of W on t_1, t_2 . If we give an arbitrary increment $t_3 - t_2$ to the interval $t_2 - t_1$ through which any sequence operates, the function $W(1, t_1, t_2)$ receives an increment

$$W(1, t_1, t_3) - W(1, t_1, t_2) = W[1 + W(1, t_1, t_2), t_2, t_3];$$

or, if we factor the heat-absorption out of the last term and rearrange,

$$1 + W(1, t_1, t_3) = [1 + W(1, t_1, t_2)] [1 + W(1, t_2, t_3)];$$

or

$$q(t_1, t_3) = q(t_1, t_2)q(t_2, t_3), \tag{12}$$

when we define a function q by

$$q(t_i, t_j) = Q(1, t_i, t_j) = 1 + W(1, t_i, t_j).$$

Now, since $W(1, t_1, t_2) = 0$ for $t_2 = t_1$, we find $q(t_1, t_2) = 1$ for $t_2 = t_1$, wherefore we obtain from (12) that

$$q(t_1, t_2)q(t_2, t_1) = 1. \tag{14}$$

Further, because of the theorems that when $x \neq 0$ and $t_2 > t_1$, the quantities x, W have the same sign, and that $W = 0$ for $t_2 = t_1$, we observe that

$$\begin{aligned} t_2 < t_1, & \quad 0 < q(t_1, t_2) < 1; \\ t_2 = t_1, & \quad q(t_1, t_2) = 1; \\ t_2 > t_1, & \quad q(t_1, t_2) > 1. \end{aligned} \tag{15}$$

If now in (12) we put $t_2 = a$, and then put $t_3 = t_2$, and apply (14), we obtain

$$q(t_1, t_2) = q(t_1, a)q(a, t_2) = \frac{q(a, t_2)}{q(a, t_1)} = \frac{\theta(t_2)}{\theta(t_1)}.$$

Here $\theta(t)$, since it is equal to $q(a, t)$, is positive by (15). Again, since $q(t_1, t_2) > 1$ for $t_2 > t_1$, it appears that

$$\frac{\theta(t_2)}{\theta(t_1)} > 1, \quad t_2 > t_1,$$

that is, that θ is an increasing function. Thus θ is a positive, increasing, single-valued, continuous function of t .

Finally, from

$$W = W(1, t_1, t_2)x = [q(t_1, t_2) - 1]x = \left(\frac{\theta(t_2)}{\theta(t_1)} - 1\right)x,$$

we find that the form of W is expressed by the identity

$$W(x, t_1, t_2) = \frac{\theta(t_2) - \theta(t_1)}{\theta(t_1)} x.$$

When a temperature of reference t_r is the "ice point," and we put $t_1 = t_r$ and $t_2 = t$, we have the successive equations

$$\frac{Q}{x_r} = 1 + W(1, t_r, t) = q(t_r, t) = \frac{\theta(t)}{\theta(t_r)}. \quad (20 b)$$

Since the ratio Q/x_r is independent of the nature of the body developing the heat Q at the general temperature t , it is employed to define the ratio of an "absolute" temperature $\theta(t)$ to its arbitrary positive value $\theta(t_r)$ at the temperature of reference t_r .

To fix the arbitrary constant $\theta(t_r)$, let Δ units be assigned to the change of θ from t_r to the "boiling point" t_s . This gives $\theta(t_r) = \Delta / W(1, t_r, t_s)$, which converts the last equation of (20 b) to

$$\theta = \frac{\Delta}{W_{rs}} \cdot q(t_r, t).$$

For positive Δ , this equation defines the absolute temperature θ of any body having the uniform temperature t by a positive, increasing, single-valued, continuous function of t .

CHAPTER X

THE GENERAL CYCLIC CHANGE OF STATE OF AN AUXILIARY FLUID

A Theorem on Carnot Cycles. On equating the first and last members of the equations (20 *a*) and writing Q_1 for the heat x absorbed at t_1 , and Q_2 for the heat $-Q$ absorbed at t_2 , by any Carnot cycle operating between t_1 and t_2 , we find that Q_1 , Q_2 and the corresponding temperatures are connected by the relation

$$\frac{Q_1}{\theta(t_1)} + \frac{Q_2}{\theta(t_2)} = 0. \quad (23)$$

It may be noted here that successive elimination of Q_1 and Q_2 between $Q_1 + W = -Q_2$ and (23) yields

$$-W = \frac{\theta_2 - \theta_1}{\theta_2} Q_2 = \frac{\theta_2 - \theta_1}{\theta_1} (-Q_1).$$

When $t_2 > t_1$ and $Q_2 > 0$, we observe that the fractional part $(\theta_2 - \theta_1)/\theta_2$ of the heat-absorption Q_2 is converted into work. This fraction is the *efficiency* of the cycle.

An Auxiliary Fluid. It is now proposed to assume the existence of a continuous field of realizable aeriform states of thermodynamic equilibrium (states of gas or of vapor) of some body such as a mass of hydrogen or of helium.

It is assumed that the body absorbs or develops work only under the action of an imposed uniform and normally directed pressure, and that the density, pressure, and temperature of the body are uniform.

It is assumed that the pressure p and the energy E of the body are single-valued continuous functions of the independently variable volume V and temperature t of the body, that these functions possess continuous first derivatives, and that the range of values of t in the field of states is the range of the experimentally realizable uniform temperatures of the body.

It is assumed that the states of the field are in continuous one-to-one correspondence with the points of a region of the V, t plane bounded by a closed contour having no double points, and hence that any reversible path of change of the thermodynamic state of the body is represented by a path in the region, and that any path in the region represents a reversible path of a change of the state.

It is assumed finally that within any area of the region, however small, it is always possible to describe a Carnot cycle whose contour encloses a finite area.

Formulation of the Theorem on Carnot Cycles. The work added to the postulated fluid body in any reversible change of its state from a state a to a state b is the line integral

$$W_{ab} = - \int_{V_a}^{V_b} p dV,$$

taken along the path of the change of state.* The energy law,

$$E_b - E_a = W_{ab} + Q_{ab},$$

where Q_{ab} is the heat absorbed on the path, is thus formulated by

$$E_b - E_a = - \int_{V_a}^{V_b} p dV + Q_{ab}.$$

Hence the heat absorbed is

$$E_b - E_a + \int_{V_a}^{V_b} p dV,$$

which is the corresponding line integral of the inexact differential expression

$$dE + p dV.$$

With reference to the independent variables V, t , this "heat-element" of the body for the region has the form

$$\left(\frac{\partial E}{\partial V} + p \right) dV + \frac{\partial E}{\partial t} dt. \tag{24}$$

We can now formulate (23) for any Carnot cycle described within the postulated region R of states. If the ratio of the heat-

* See the explanation on page 15.

element (24) to the absolute temperature $\theta(t)$ is integrated along an isothermal path it yields a quantity Q/θ , where Q is the heat absorbed on the path. For, if we denote the heat-element (24) by the symbol DQ , we have, at constant temperature,

$$\int \frac{DQ}{\theta} = \frac{1}{\theta} \int DQ = \frac{Q}{\theta}.$$

We have also that, along an adiabatic path, $DQ = 0$ and $\theta > 0$, wherefore a line integral of the expression DQ/θ taken along any adiabatic path is equal to zero. Hence the equation (23) is formulated by

$$\int_{CC} \left[\frac{1}{\theta} \left(\frac{\partial E}{\partial V} + p \right) dV + \frac{1}{\theta} \frac{\partial E}{\partial t} dt \right] = 0, \quad (25)$$

where the double subscript indicates that the line integral is taken along the contour of *any Carnot cycle* in the region.

The General Cyclic Change of State of the Fluid. Now let us consider this same line integral, taken along *any* closed contour C in the region R . If, by Green's theorem, we transform the integral into a surface integral over the enclosed area, we obtain

$$\begin{aligned} & \int_C \left[\frac{1}{\theta} \left(\frac{\partial E}{\partial V} + p \right) dV + \frac{1}{\theta} \frac{\partial E}{\partial t} dt \right] \\ &= \iint \left[\frac{\partial}{\partial V} \frac{1}{\theta} \frac{\partial E}{\partial t} - \frac{\partial}{\partial t} \frac{1}{\theta} \left(\frac{\partial E}{\partial V} + p \right) \right] dV dt \\ &= \iint \frac{1}{\theta} \left[\left(\frac{\partial E}{\partial V} + p \right) \frac{1}{\theta} \frac{d\theta}{dt} - \frac{\partial p}{\partial t} \right] dV dt. \end{aligned} \quad (26)$$

If the integrand of the surface integral were positive (or negative) at all points within any subregion R_1 , however small, the surface integral extended over the area enclosed by any contour within R_1 would be positive (or negative), as therefore would be the line integral taken along the contour.

But this is impossible, since the contour may be that of a Carnot cycle, for which by (25) the line integral is equal to zero. And the integrand cannot be positive (or negative) at all points of a finite line segment, or at isolated points, since it is continuous.

Hence the integrand of the surface integral is equal to zero at *all* points in the field of homogeneous fluid states; and thus the surface integral extended over any finite area is equal to zero; wherefore the line integral taken along the contour C of the area is equal to zero. If we again write DQ for the heat-element for the region, that is for the inexact linear differential expression

$$DQ = \left(\frac{\partial E}{\partial V} + p \right) dV + \frac{\partial E}{\partial t} dt,$$

we thus find that
$$\int_C \frac{DQ}{\theta(t)} = 0. \quad (27)$$

The Case of n Variables. In establishing the result (27) it may even be assumed that the states of equilibrium of the postulated fluid are determined by any finite number n of independent variables. If the work-element of the fluid is a linear differential form

$$\sum_{i=1}^n p_i dx_i,$$

where the n variables x_i are independent and the coefficients p_i are functions of them, and if the energy E of the fluid is a single-valued continuous function of the x_i and possesses continuous first derivatives, then the heat-element of the fluid is

$$dE - \sum_1^n p_i dx_i = \sum_1^n \left(\frac{\partial E}{\partial x_i} - p_i \right) dx_i = DQ.$$

Hereupon, if the coefficients $\partial E / \partial x_i - p_i$ have continuous first derivatives, we can formulate the equation corresponding to (25), and proceed as before to draw the conclusion (27).

The Absolute Temperature. The fact that the integrand of the surface integral in (26) is everywhere equal to zero,

$$\left(\frac{\partial E}{\partial V} + p \right) \frac{1}{\theta} \frac{d\theta}{dt} - \frac{\partial p}{\partial t} = 0, \quad (28)$$

affords a differential equation for the absolute temperature $\theta(t)$.

If the postulated fluid body be a mass of hydrogen, this equation brings θ into connection with measurable properties of hydrogen. In order to integrate (28), we must know the forms of the functions p and $\partial E / \partial V$ of the variables V, t . For ~~the~~

arbitrary temperature t we select the temperature T of the centigrade scale of the standard hydrogen thermometer, as described on page 2. Now it is a fact of observation that, under any relatively low constant pressure p , the specific volume v of hydrogen* is closely proportional to the quantity $T + 273$,

$$v = \phi(p) \cdot (T + 273); \quad (29)$$

and, again under low pressures, it is true that to a close approximation p and v are inversely proportional at any constant temperature,

$$pv = \psi(T). \quad (30)$$

On combining (29) and (30) by eliminating v , and separating the variables, we find

$$\phi(p) \cdot p = \frac{\psi(T)}{T + 273};$$

where each member is equal to a constant r , since p , T are independent. This result converts either of the equations (29) and (30) to

$$p = \frac{r(T + 273)}{v},$$

which becomes

$$p = \frac{mr(T + 273)}{V}, \quad (31)$$

when v is replaced by V/m , where m is the mass of the gas. Finally, since abrupt expansion of the body of gas into a vacuum alters the temperature but slightly, experiment indicates that the energy of the body is sensibly independent of the volume, that is that

$$\frac{\partial E}{\partial V} = 0. \quad (32)$$

On making use of the data (31) and (32), the equation (28) becomes

$$\frac{1}{\theta} \frac{d\theta}{dT} = \frac{\frac{\partial p}{\partial T}}{\frac{\partial E}{\partial V} + p} = \frac{\frac{mr}{V}}{0 + \frac{mr(T + 273)}{V}} = \frac{1}{T + 273};$$

whence, by integration,

$$\theta = c(T + 273).$$

* The "specific" volume is the volume of unit mass.

To determine the integration constant c , let T_r and T_s be the ice point and the boiling point. Then

$$\theta(T_s) - \theta(T_r) = c(T_s - T_r),$$

that is $100 = c \cdot 100$, or $c = 1$. Hence

$$\theta = T + 273.$$

It thus appears that the scale of absolute temperatures differs but slightly from the scale of the hydrogen thermometer when the value 273 is assigned to the ice point. The result is an approximation because the formulations (31) and (32) are approximations. Yet the approximation is, in fact, a very close one. Means of obtaining a more accurate formulation of the relation of θ to T will be described in Chapter XII.*

Synopsis. Since the function $q(t_1, t_2)$ is equal to Q/x , and has the form $\theta(t_2)/\theta(t_1)$, we have

$$\frac{Q}{x} = \frac{\theta(t_2)}{\theta(t_1)}.$$

If $Q_1 = x$ and $Q_2 = -Q$ are the quantities of heat *absorbed* by the working body in the operation of any Carnot cycle, it thus appears that Q_1, Q_2, t_1, t_2 are connected by the relation

$$\frac{Q_1}{\theta(t_1)} + \frac{Q_2}{\theta(t_2)} = 0. \tag{23}$$

The heat-element of a selected auxiliary fluid body is the expression

$$DQ = dE + pdV = \left(\frac{\partial E}{\partial V} + p \right) dV + \frac{\partial E}{\partial t} dt.$$

* If we use the Fahrenheit scale of the hydrogen thermometer, when $\tau = 32$ is the temperature of the ice point, the number 273 in (29) and (31) is replaced by 460. Hence we find

$$\theta = c(\tau + 460).$$

Then the equation $\theta(\tau_s) - \theta(\tau_r) = c(\tau_s - \tau_r)$

yields $180 = c \cdot 180$, or $c = 1$,

wherefore $\theta = \tau + 460$.

Incidentally, $\theta(\tau_r) = 32 + 460 = 492^\circ \text{F}$.

Dividing this expression by θ , and integrating it along the contour of any Carnot cycle in the V, t plane, we obtain (23) in the form

$$\int_{CC} \frac{DQ}{\theta} = \int_{CC} \left[\frac{1}{\theta} \left(\frac{\partial E}{\partial V} + p \right) dV + \frac{1}{\theta} \frac{\partial E}{\partial t} dt \right] = 0. \quad (25)$$

Now, applying Green's theorem to the line integral of the same expression taken along *any* closed contour C in the V, t plane,

$$\int_C \left[\frac{1}{\theta} \left(\frac{\partial E}{\partial V} + p \right) dV + \frac{1}{\theta} \frac{\partial E}{\partial t} dt \right] = \iint \frac{1}{\theta} \left[\left(\frac{\partial E}{\partial V} + p \right) \frac{1}{\theta} \frac{d\theta}{dt} - \frac{\partial p}{\partial t} \right] dV dt.$$

But the integrand of the surface integral cannot be positive (or negative) at all the points of any subregion R_1 , else the line integral taken along the contour of a Carnot cycle within R_1 would be positive (or negative), in conflict with (25). Hence the line integral of the expression DQ/θ , taken along any closed contour C in the plane, is equal to zero,

$$\int_C \frac{DQ}{\theta(t)} = 0.$$

A differential equation for the absolute temperature is afforded by the fact that the integrand of the above surface integral is everywhere equal to zero,

$$\frac{1}{\theta} \frac{d\theta}{dt} = \frac{\partial p}{\partial t} \left(\frac{\partial E}{\partial V} + p \right)^{-1}. \quad (28)$$

If, for hydrogen under low pressures, we employ the approximately true relations $\partial E/\partial V = 0$ and $p = mr(T + 273)/V$, where T is the reading of the scale of the standard hydrogen thermometer with the ice point at $T = 0$, integration of (28) yields $\theta = T + 273$. It appears that the scale of absolute temperatures differs but slightly from the scale of the hydrogen thermometer when the value 273 is assigned to the ice point.

CHAPTER XI

THE ENTROPY OF A BODY

The General Cyclic Change of State. It is now proposed to examine the general reversible cyclic change of state of any body, by connecting it with a cyclic change of state of the auxiliary gas studied in the preceding chapter. Let *any* body *B* undergo *any* possible reversible cyclic change of thermodynamic state,* the process being so conducted that all work transferred to or from *B* is exchanged with a mechanism *M*, and all heat transferred is exchanged with the auxiliary gas *G* in thermal equilibrium with *B*; while all work transferred to or from *G* is exchanged with *M*. The process may be followed with reference to Fig. 26. At the conclusion of the cycle the body *B* regains its initial state and energy. It then appears that the gas *G*

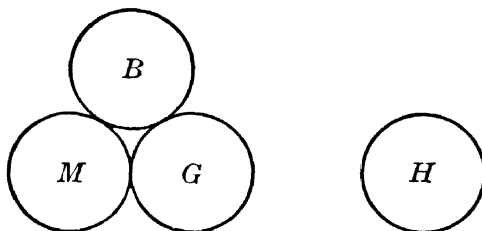

FIG. 26

has regained its initial temperature, and either has or has not regained its initial volume and hence its initial energy.

Suppose the final volume of the gas *G* to differ from the initial volume. On returning *G* to its initial state by reversible isothermal expansion or compression, the gas exchanges work with *M* and absorbs heat q from an outside body *H*, whereby q must be either positive, negative, or zero.† If q is positive, the change

* It should be borne in mind that the change of state may be wholly or partly isothermal.

† It is possible for a fluid to develop heat in isothermal expansion, and hence to absorb it in isothermal compression. For this behavior occurs in a region in which $\partial p/\partial t < 0$, where $p(v, t)$ is the pressure of the fluid. And it is possible for a fluid to traverse a path of isothermal expansion such that the heat absorbed on a certain segment of the path is equal to that developed on the remaining segment, wherefore $q = 0$. For this behavior can occur in a case in which the path crosses a locus of maximum density (at constant pressure). To exclude these possibilities would be to make unnecessary assumptions.

of state of M is a net absorption of work q , which absorption is supplemented by the isothermal development of heat by H .^{*} This violates the second law. If q is negative, the change of state of M is a net development of work q , which development supplements the isothermal absorption of heat by H . A reversal of the whole succession of operations would cause M to absorb work q at the expense of an isothermal development of heat by H ,^{*} thus again violating the second law. So q can be neither positive nor negative. There remains the possibility that $q = 0$.

Heat-Elements. It is now desired to find that the heat absorbed by the body B , on any reversible path in any region R_i of the realizable states of equilibrium of B , is equal to the corresponding line integral of a linear differential expression in the variables that determine the states of R_i . We assume that these states are in continuous one-to-one correspondence with the values of a finite number n_i of measurable independent variables,

$$x_{i1}, x_{i2}, \dots, x_{in_i};$$

that the uniform temperature t of the body is one of the variables, or is a function of the variables, and may in particular be a constant; that the energy E_i of the body for the region is a single-valued continuous function of these variables; and that this function possesses continuous first derivatives.

We assume that the body is in equilibrium under an imposed uniform temperature and under a finite number of imposed forces; that the work absorbed by the body on any reversible path of change of its state can be considered to be developed by a mechanism M connected with the body; and that the work absorbed on any path in the region R_i is equal to the corresponding line integral of a linear expression

$$DW_i = p_{i1}dx_{i1} + p_{i2}dx_{i2} + \dots + p_{in_i}dx_{in_i},$$

in which the p_{ij} are continuous functions of the x_{ij} , and which in general is inexact.

^{*} For the energy of the body composed of B , G , and M is increased by q ; wherefore the energy of M is increased by q , since the energies of B and G have their initial values.

It then follows, by the energy law $dE_i = DW_i + DQ_i$, that the heat-element DQ_i for the region is a similar linear expression,

$$\begin{aligned} DQ_i &= dE_i - \sum_{j=1}^{n_i} p_{ij} dx_{ij} \\ &= \sum_{j=1}^{n_i} \left(\frac{\partial E_i}{\partial x_{ij}} - p_{ij} \right) dx_{ij} \\ &= q_{i1} dx_{i1} + q_{i2} dx_{i2} + \dots + q_{in_i} dx_{in_i}, \end{aligned}$$

in which the q_{ij} are continuous functions of the x_{ij} , and which in general is inexact.

The Entropy of a Body. Let us first suppose that the above described cyclic path of the change of state of B lies wholly within a region R_i . At every stage of the cycle the temperatures of B and G are equal, and the heat DQ_i absorbed by B is equal to the negative of the heat DQ_g absorbed by G . By integration along the entire cyclic path, therefore, we have that

$$\int \frac{DQ_i}{\theta(t)} = - \int \frac{DQ_g}{\theta(t)}.$$

But, by (27), the second member of this equation is equal to zero. For the gas G either regains its initial state when B does, or it can be restored to this state along an isothermal path on which it absorbs heat $q = 0$. So, on taking the line integral along any cyclic path C of change of the state of any body B within any region R_i , we find that

$$\int_C \frac{DQ_i}{\theta(t)} = 0, \tag{33}$$

where the temperature t is a function of the regional variables, and may in particular be one of the variables or be a constant. It follows that the integrand in (33) is the differential of a continuous function S_i of the regional variables,*

$$\frac{DQ_i}{\theta(t)} = dS_i, \tag{34}$$

and that this function has continuous first derivatives.

* It is of the first importance to note that the conclusion (34) cannot be drawn unless it is known that DQ_i is a linear differential form. If the symbol DQ_i represented merely a physical element of heat, the conclusion would not be known to be true.

In general, if the cyclic path of the change of state of B traverses successive regions R_a, R_b, \dots, R_a , integration along the path gives

$$\int \frac{DQ_a}{\theta} + \int \frac{DQ_b}{\theta} + \dots + \int \frac{DQ_a}{\theta} = 0, \quad (35)$$

where each term of the sum of line integrals is taken along the path-segment lying in the corresponding region. Now, since the function S_i is defined by its differential, only the excess of this function over its value at a state of reference has a meaning. In a conveniently selected region R_0 let us locate a state of reference, specified by the set ρ of the values of the regional variables there. We may then define the function S_i at the general state σ of the general region R_i by integration along any reversible path of the change of state $\rho\sigma$,

$$S_i = \int_{\rho} \frac{DQ_0}{\theta} + \dots + \int^{\sigma} \frac{DQ_i}{\theta}.$$

The quantity so defined is independent of the path between ρ and σ . For any path of the change $\rho\sigma$, followed by any other path of the change $\sigma\rho$, is a cyclic path, for which by (35) we have that S_i with reference to the first path minus S_i with reference to the second is equal to zero. The quantity S_i is termed the *entropy* of the body for the region R_i . It is a single-valued continuous function of the variables employed to determine the states of the region, and it possesses continuous first derivatives.

On crossing the boundary separating a region R_i from a region R_j , the entropy S_i is replaced by the entropy S_j , which in general is a function of a different set of independent variables and has a different analytical form.

The theorem that the ratio of any regional heat-element to the absolute temperature is the differential of a single-valued continuous function having continuous first derivatives may suitably be termed the *entropy law*.

The Formulation of Heat-Elements. When a body whose volume is V_i in the region R_i is supposed subject to no force

other than a uniform and normally directed pressure p , the work-element

$$DW_i = -pdV_i$$

of the body for the region is expressed in terms of two functions p and V_i . Similarly, when the formulation (34)

$$\frac{DQ_i}{\theta} = dS_i$$

of the discovery that every differential expression DQ_i/θ is exact, is written in the form

$$DQ_i = \theta dS_i, \quad (36)$$

it expresses the heat-element of the body for the region in a similar way in terms of two functions θ and S_i . Hence, if the symbols a and b denote the respective sets of values of the variables determining an initial state a and a final state b of the body, the work W_{ab} and the heat Q_{ab} absorbed on a reversible path of the change of state from a to b are equal to the line integrals, taken along the path, of the work-element and of the heat-element respectively,

$$W_{ab} = - \int_a^b pdV_i, \quad Q_{ab} = \int_a^b \theta dS_i. \quad (37)$$

It appears that *reversible* adiabatic transfers of work, in which $DQ_i = 0$, occur at constant entropy. They are said to be *isentropic*. Irreversible adiabatic changes of state are not isentropic. They will be studied in Chapter XIII.

Writing v for the volume and s for the entropy of unit mass of a typical fluid, Fig. 27 is a chart of isotherms in the v, p plane, and Fig. 28 is a chart of isobars in the s, θ plane, for the body. Both figures include parts of the regions for homogeneous fluid and for coexistent liquid and vapor. In both figures the evaporation field is crossed by horizontal isotherms, and in both the regions for liquid and for vapor lie respectively to the left and to the right of this field. Large-scale charts of these types are very convenient substitutes for corresponding tabulations of experimental data. Because of the first of equations (37), the work developed by the body in a change of state along any

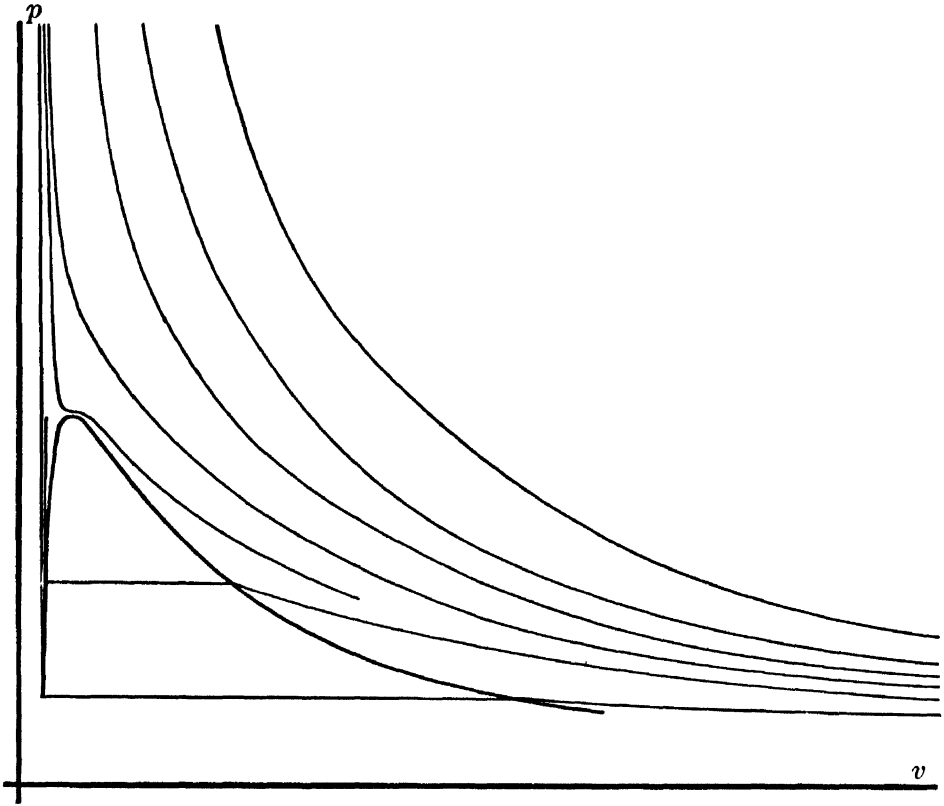

FIG. 27

path in the v, p plane is equal to the area swept over by the ordinate of the representative point as it traverses the path. And, similarly, because of the second of equations (37), the heat absorbed by the body in a change along any path in the s, θ plane is equal to the area swept over by the ordinate of the representative point as it traverses this path.

Integrating Factors of Heat-Elements. In the formulation (34) of the entropy law,

$$\frac{1}{\theta(t)} DQ_i = dS_i,$$

it appears that the function $1/\theta(t)$ is an integrating factor of the heat-element DQ_i . It appears also that the heat-element of a body for an *isothermal* region, being the differential of the function θS_i , is an exact expression; and hence that the quantities of heat absorbed by a body on coterminous isothermal paths are equal.

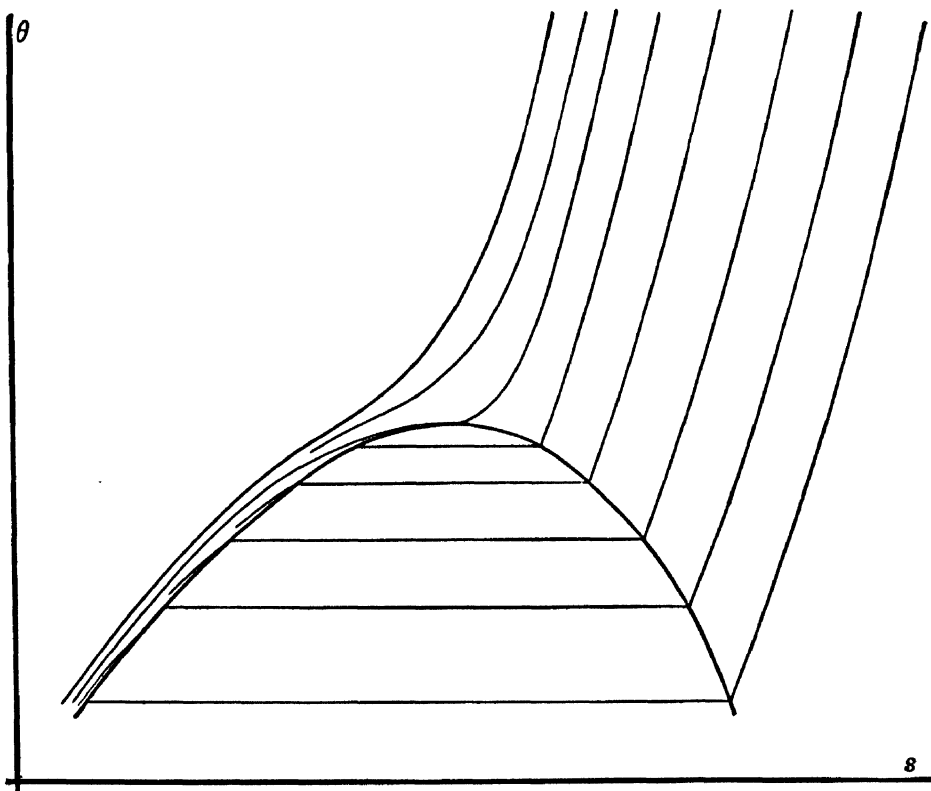

FIG. 28

Let DQ_i be the heat-element for any non-isothermal region when t is one of the regional variables. When DQ_i has an integrating factor,

$$\frac{1}{\theta} DQ_i = dS_i,$$

it has others. Any other factor $1/\theta'$ has the form

$$\frac{1}{\theta'} = f(S_i) \frac{1}{\theta},$$

where the arbitrary function $f(S_i)$ contains *all* the independent variables. Since θ is a function of but one variable, it follows that any other integrating factor contains the other variables, and may contain all the variables. Hence the absolute temperature $\theta(t)$ is determined by the circumstance that it is the only integrating divisor of DQ_i , that is a function of the temperature alone.

The theorem that the ratio of any two integrating factors of a linear differential form,

$$X_1 dx_1 + X_2 dx_2 + \dots + X_n dx_n,$$

is a function of all the n independent variables may be proved as follows. If f is an integrating factor it must satisfy the equations

$$\frac{\partial}{\partial x_i} f X_j = \frac{\partial}{\partial x_j} f X_i, \quad i \neq j; \quad i, j = 1, 2, \dots, n. \quad (a)$$

If f_1, f_2 are any two integrating factors they must satisfy (a). Hence

$$\begin{aligned} f_1 \frac{\partial X_j}{\partial x_i} + X_j \frac{\partial f_1}{\partial x_i} &= f_1 \frac{\partial X_i}{\partial x_j} + X_i \frac{\partial f_1}{\partial x_j}, \\ f_2 \frac{\partial X_j}{\partial x_i} + X_j \frac{\partial f_2}{\partial x_i} &= f_2 \frac{\partial X_i}{\partial x_j} + X_i \frac{\partial f_2}{\partial x_j}. \end{aligned}$$

By multiplying the first of these equations through by f_2 and the second by $-f_1$, and adding, we find

$$X_j \left(f_2 \frac{\partial f_1}{\partial x_i} - f_1 \frac{\partial f_2}{\partial x_i} \right) = X_i \left(f_2 \frac{\partial f_1}{\partial x_j} - f_1 \frac{\partial f_2}{\partial x_j} \right);$$

or, on dividing each member by f_2^2 ,

$$X_j \frac{\partial}{\partial x_i} \frac{f_1}{f_2} = X_i \frac{\partial}{\partial x_j} \frac{f_1}{f_2};$$

or, in particular,

$$\frac{\partial}{\partial x_2} \frac{f_1}{f_2} = \frac{X_2}{X_1} \frac{\partial}{\partial x_1} \frac{f_1}{f_2}, \quad \frac{\partial}{\partial x_3} \frac{f_1}{f_2} = \frac{X_3}{X_1} \frac{\partial}{\partial x_1} \frac{f_1}{f_2}, \text{ etc.} \quad (b)$$

Hereupon the differential of the ratio f_1/f_2 ,

$$d \frac{f_1}{f_2} = \frac{\partial}{\partial x_1} \frac{f_1}{f_2} dx_1 + \frac{\partial}{\partial x_2} \frac{f_1}{f_2} dx_2 + \dots + \frac{\partial}{\partial x_n} \frac{f_1}{f_2} dx_n,$$

is converted by the substitutions (b) to

$$d \frac{f_1}{f_2} = \frac{1}{X_1} \frac{\partial}{\partial x_1} \frac{f_1}{f_2} \cdot (X_1 dx_1 + X_2 dx_2 + \dots + X_n dx_n);$$

whence follows, by integration,

$$\frac{f_1}{f_2} = \phi(x_1, x_2, \dots, x_n).$$

Since the second member of this equation contains all the independent variables, the theorem is proved.

The circumstance that the function $1/\theta(t)$ is an integrating factor of any non-isothermal heat-element imposes certain restrictions on the forms of heat-elements. To illustrate, let

$$q_1 dx_1 + q_2 dx_2 + \dots + q_n dx_n + c dt$$

be the heat-element for a region of states determined by the regional variables x_1, x_2, \dots, x_n, t . Then the expression

$$\frac{q_1}{\theta} dx_1 + \frac{q_2}{\theta} dx_2 + \dots + \frac{q_n}{\theta} dx_n + \frac{c}{\theta} dt$$

is exact, which necessitates a set of conditions

$$\frac{\partial q_i}{\partial x_j} = \frac{\partial q_j}{\partial x_i}, \tag{38}$$

and a set of conditions $\frac{\partial q_i}{\partial t} = \frac{\partial c}{\partial x_i}$,

which are n conditions of the form

$$\frac{1}{q_i} \left(\frac{\partial q_i}{\partial t} - \frac{\partial c}{\partial x_i} \right) = \frac{1}{\theta} \frac{d\theta}{dt}. \tag{39}$$

The coefficients q_i, c of the heat-element must be such as to satisfy the two sets of conditions (38) and (39).

The equations (39) are differential equations for the absolute temperature. Let us consider them for a body consisting of unit mass of hydrogen gas. If the energy e and the pressure p of the body are functions of the volume v and the temperature T of the hydrogen scale, we have

$$DQ = de + pdv = \left(\frac{\partial e}{\partial v} + p \right) dv + \frac{\partial e}{\partial T} dT,$$

wherefore $q_1 = \frac{\partial e}{\partial v} + p, \quad c = \frac{\partial e}{\partial T}$.

If, as on page 56, we introduce the approximation $\partial e / \partial v = 0$, wherefore

$$q_1 = p, \quad \text{and} \quad \frac{\partial c}{\partial v} = \frac{\partial}{\partial T} \frac{\partial e}{\partial v} = 0,$$

and also the approximation $p = r(T + 273)v^{-1}$, the equation (39) for $i = 1$ becomes

$$\frac{1}{\theta} \frac{d\theta}{dT} = \frac{1}{p} \frac{\partial p}{\partial T} = \frac{rv^{-1}}{r(T + 273)v^{-1}} = \frac{1}{T + 273},$$

which is the equation obtained on page 56.

Synopsis. If the work-element for any body B , in any region R_i of its states of equilibrium, is a linear expression DW_i in the regional variables, it follows that the heat-element for the region is a linear expression DQ_i in these variables. Both expressions are in general inexact.

By coupling a mechanism M with *any* body B and with an auxiliary body G of gas in thermal equilibrium with B , it may be shown (by means of the second law) that *any* possible reversible cyclic change of the thermodynamic state of B can be associated with a reversible cyclic change of the state of G in such a manner that all heat developed by either body is absorbed by the other.

If the cyclic path C of the change of state of B lies in a region R_i of states, we thus find that

$$\int_C \frac{DQ_i}{\theta(t)} = 0. \quad (33)$$

It follows that the integrand in (33) is the differential of a continuous function S_i of the regional variables,

$$\frac{DQ_i}{\theta(t)} = dS_i, \quad (34)$$

and that this function has continuous first derivatives.

Since the function S_i is defined by its differential, it contains an arbitrary additive constant. To provide this constant, the quantity S_i at the general state σ of the general region R_i is defined with reference to a state of reference ρ in a region R_0 . If any reversible path of the change of state $\rho\sigma$ traverses successive regions R_0, R_a, \dots, R_i , the quantity S_i at the state σ is defined by integration along the path,

$$S_i = \int_{\rho} \frac{DQ_0}{\theta} + \int \frac{DQ_a}{\theta} + \dots + \int^{\sigma} \frac{DQ_i}{\theta},$$

where each term of the sum of line integrals is taken along the path-segment lying in the corresponding region. The quantity so defined is independent of the path. For the sum $S_i' - S_i''$ obtained by integrating along a cyclic path composed of any path of the change of state $\rho\sigma$, followed by any other path of the change $\sigma\rho$, is equal to zero. The single-valued continuous

function S_i is the *entropy* of the body B for the region R_i . The theorem that the ratio of any regional heat-element to the absolute temperature is the differential of a single-valued continuous function having continuous first derivatives is the *entropy law*.

From (34) it appears that any regional heat-element DQ_i has the formulation

$$DQ_i = \theta dS_i,$$

where θdS_i is in general inexact. In an isothermal region the expression is exact. Reversible adiabatic transfers of work, for which $DQ_i = 0$, are *isentropic* processes (but *irreversible* adiabatic transfers are not). The heat absorbed by a body in a change of state occurring along any path in the S_i, θ plane is equal to the area swept over by the ordinate of the representative point. The absolute temperature is the only integrating divisor of DQ_i that is a function of the temperature t alone.

CHAPTER XII

THE SCALE OF ABSOLUTE TEMPERATURES

A Differential Equation for θ . In the foregoing it has been made clear that the definition of the absolute temperature θ defines the ratio of this quantity to its value at a fixed temperature,

$$\frac{\theta}{\theta(t_r)} = 1 + W(1, t_r, t), \quad (40)$$

where W is the work absorbed by any sequence absorbing heat 1 at a temperature of reference t_r and operating between t_r and the general temperature t . Since it is a ratio that is defined, the quantity θ contains an arbitrary multiplicative constant. In the formulation into which (40) is transformed,

$$\theta = \frac{\Delta}{W_{rs}} [1 + W(1, t_r, t)],$$

this constant Δ/W_{rs} depends on the number Δ of units assigned to the interval $\theta(t_s) - \theta(t_r)$ between the ice point and the boiling point of water.

When the definition of θ was expressed, in Chapter X, in terms of properties of any homogeneous fluid whose states of thermodynamic equilibrium are determined by the specific volume v and the temperature t , the procedure was essentially as follows. In the independent variables v, t , the differential $de = -pdv + \theta ds$ of the specific energy e of the fluid is

$$de = \left(-p + \theta \frac{\partial s}{\partial v}\right) dv + \theta \frac{\partial s}{\partial t} dt,$$

where s is the entropy of unit mass of the fluid. From this equation we find the condition of integrability of the second member, and a formulation of the derivative $(\partial t/\partial v)_e$,*

$$-\frac{\partial p}{\partial t} + \frac{d\theta}{dt} \frac{\partial s}{\partial v} = 0, \quad \left(\frac{\partial t}{\partial v}\right)_e = \frac{1}{c_v} \left(p - \theta \frac{\partial s}{\partial v}\right); \quad (41)$$

* The symbol $(\partial t/\partial v)_e$ denotes the rate of change of t per unit change of v at constant e . It is the derivative of the function $t(v, e)$ with regard to v .

where the heat $\theta \cdot \partial s / \partial t$ absorbed by unit mass per degree at constant volume is the "specific heat at constant volume" c_v of the fluid. On eliminating $\partial s / \partial v$ between the equations (41), we obtain a differential equation for θ ,

$$\frac{1}{\theta} \frac{d\theta}{dt} = \frac{\frac{\partial p}{\partial t}}{p - c_v \left(\frac{\partial t}{\partial v} \right)_e}, \quad (42)$$

which can be integrated when the forms of the functions p , c_v , and $(\partial t / \partial v)_e$ of the independent variables v, t shall have been determined by experiment.

The Porous Plug Effect. The weak feature of the formulation (42) consists in the employment of the "free expansion effect" $(\partial t / \partial v)_e$. For measurements of the changes of temperature of a gas on free (that is, unhindered) expansion into vacua cannot be made with sufficient accuracy. Now, accurate equivalent data are obtainable by measuring the changes of temperature of a thermometric gas on expansion against reduced opposing pressures. A supply of gas maintaining the pressure p_1 at

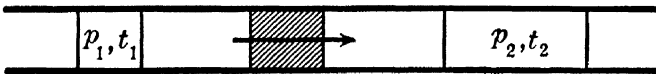

FIG. 29

the temperature t_1 is allowed to stream through a resisting porous plug, in a thermally insulated tube, against an adjustable back pressure p_2 . The pump maintaining the pressure p_1 adds work $p_1 v_1$ to unit mass of the gas on driving it through its volume v_1 , while at the same time an equal mass develops the work $p_2 v_2$ against the back pressure. Hence, neglecting the small kinetic energy involved, the change of the energy of unit mass is

$$e_2 - e_1 = p_1 v_1 - p_2 v_2 ;$$

wherefore we observe that

$$e_1 + p_1 v_1 = e_2 + p_2 v_2 ;$$

that is, that the process occurs under the condition of constant $e + pv$. Measurement of the temperature t_2 of the issuing gas determines the ratio

$$\left(\frac{t_2 - t_1}{p_2 - p_1}\right)_{e+pv},$$

and from such determinations it is possible to formulate the "porous plug effect,"

$$\left(\frac{\partial t}{\partial p}\right)_{e+pv} = \psi(p, t).$$

A New Differential Equation for θ . To connect the porous plug effect with the absolute temperature, we must formulate the relation between the differentials of t , p , and $e + pv$. Differentiating the function $e + pv$,

$$d(e + pv) = de + pdv + vdp,$$

and eliminating the differential $de = -pdv + \theta ds$ of the specific energy of the gas,

$$d(e + pv) = vdp + \theta ds,$$

or, in the independent variables p, t ,

$$d(e + pv) = \left(v + \theta \frac{\partial s}{\partial p}\right) dp + \theta \frac{\partial s}{\partial t} dt.$$

From this equation we find the condition of integrability of the second member, and a formulation of the porous plug effect,

$$\frac{\partial v}{\partial t} + \frac{d\theta}{dt} \frac{\partial s}{\partial p} = 0, \quad \left(\frac{\partial t}{\partial p}\right)_{e+pv} = -\frac{1}{c_p} \left(v + \theta \frac{\partial s}{\partial p}\right); \quad (43)$$

where the heat $\theta \cdot \partial s / \partial t$ absorbed by unit mass per degree at constant pressure is the "specific heat at constant pressure" c_p of the gas. On eliminating $\partial s / \partial p$ between the equations (43), we obtain a new differential equation for θ ,

$$\frac{1}{\theta} \frac{d\theta}{dt} = \frac{\frac{\partial v}{\partial t}}{v + c_p \left(\frac{\partial t}{\partial p}\right)_{e+pv}},$$

which can be integrated when the forms of v and c_p and the porous plug effect, in the independent variables p, t , shall have been determined by experiment.

As determined by the best available data, the differences between the scales of the constant-volume hydrogen, helium, and nitrogen thermometers (when the value 273 is assigned to the ice point) and the scale of absolute temperatures are within the limits of accuracy as yet attained in the use of gas thermometers.

It is easily seen that the approximations $v = rT/p$ and $\psi = 0$, for finite c_p , would yield the result $\theta = T$.

Exercise. As an exercise in manipulation, the reader is requested to show that, in the variables v, θ , the free expansion effect ϕ satisfies the equation

$$\phi = -\frac{\theta^2}{c_v} \frac{\partial p}{\partial \theta \theta};$$

that, in the variables p, θ , the porous plug effect satisfies the equation

$$\psi = +\frac{\theta^2}{c_p} \frac{\partial v}{\partial \theta \theta};$$

and that, in consequence, free expansion involves a cooling when

$$\frac{\partial p}{\partial \theta \theta} > 0,$$

and a heating when the derivative is negative; and that the porous plug effect involves a cooling when

$$\frac{\partial v}{\partial \theta \theta} > 0,$$

and a heating when this derivative is negative.

Synopsis. The form of the absolute temperature θ as a function of the temperature t of an arbitrary scale cannot be accurately determined by integration of the differential equation

$$\frac{1}{\theta} \frac{d\theta}{dt} = \frac{1}{p - c_v \phi} \left(\frac{\partial p}{\partial t} \right)_v,$$

because measurements of the free expansion effect $\phi = (\partial t / \partial v)_e$ cannot be made with sufficient accuracy. But accurate equiva-

lent data can be obtained by measurements of the porous plug effect $\psi = (\partial t / \partial p)_{e+pv}$. From

$$d(e + pv) = vdp + \theta ds = \left(v + \theta \frac{\partial s}{\partial p} \right) dp + \theta \frac{\partial s}{\partial t} dt,$$

we find the condition of integrability of the last member, and a formulation of the porous plug effect,

$$\frac{\partial v}{\partial t} + \frac{d\theta}{dt} \frac{\partial s}{\partial p} = 0, \quad \left(\frac{\partial t}{\partial p} \right)_{e+pv} = -\frac{1}{c_p} \left(v + \theta \frac{\partial s}{\partial p} \right);$$

whereupon elimination of $\partial s / \partial p$ yields

$$\frac{1}{\theta} \frac{d\theta}{dt} = \frac{1}{v + c_p \psi} \left(\frac{\partial v}{\partial t} \right)_p.$$

This equation can be integrated when the forms of v and c_p and the porous plug effect, in the independent variables p, t , shall have been determined by experiment.

CHAPTER XIII

DISSIPATION

Paths of Least Resistance. Every actually occurring change of the thermodynamic state of a body or of a set of bodies proceeds of itself, in a definite direction, and on an irreversible path. A released stone falls to the ground; a mechanism expending work against friction effects a heating; the temperatures of contiguous bodies having different temperatures approach a common intermediate value; a body of gas expands abruptly into a vacuum, or is compressed on release of a heavy piston confining it in a vertical cylinder; sugar diffuses from an aqueous solution into a supernatant layer of water; a zinc rod dissolves in aqueous acid.

If these processes are conducted under *control* they develop work against the controlling forces. The falling stone raises a weight; the mechanism compresses a spring; an air engine operates through absorbing heat from the hot body and transmitting heat to the cold one; the expanding gas develops work against a confining piston; the falling piston raises a weight by an attached cord running over a pulley; the sugar develops work against a semipermeable piston separating the solution from the water; the dissolving zinc develops an electric current that drives a motor.

To judge from these examples it would seem that spontaneously occurring thermodynamic processes can be utilized for the production of work. When such a process is conducted under complete control it is conducted reversibly, and it develops the maximum work possible. The irreversible process, then, develops the least work possible; it follows the path of least resistance.

We shall test the validity of this idea by examining a diversity of irreversible processes. It is obvious that, in each case,

the entire change of state must be considered. When, for example, two blocks of metal undergo a temperature equalization, the change of state of one block is a heating and that of the other is a cooling. These changes of state have opposite directions. The point here is that the temperatures of the *two* blocks approach a common value, that the change of state that proceeds in a definite direction is a change of state of the body composed of *both blocks*. In any case the process that proceeds in a definite direction is a change of state of the set of all the participating bodies. It is a change of state of a thermally and dynamically *isolated* body. Indeed it may be imagined to occur within a rigid and thermally non-conducting shell enclosing the set. When "isodynamic" is taken to mean "occurring at constant energy," we may say briefly that any actually occurring thermodynamic process, considered in its entirety, is adiabatic and isodynamic.

Processes of Diverse Types. 1. Impact. At a temperature θ_0 let a heavy metal ball fall into a thermally insulated receptacle. The consequent development of heat raises the temperature of the body B , composed of the ball and receptacle, to a uniform value θ_1 . The change of state of B is irreversible and adiabatic. To conduct the process on a reversible path, let the falling ball develop work w by means of a suspending cord passing over a pulley, and let the temperature of the ball and receptacle be then brought from θ_0 to θ_1 by reversible addition of w units of heat. Since positive heat is added on the reversible path, it follows that the change of the entropy of the body B was positive in the irreversible process. The energy that could have been developed as work was dissipated in producing a heating effect.

This example is perhaps not as simple as it seems. It may be objected that the body B does not constitute the assemblage of all the bodies participating in the process. It may be maintained that the process is a falling together of the ball and the earth under the action of their mutual attraction, and hence that the body undergoing a spontaneously occurring change of state is constituted of the ball on the one hand and the rest of the earth on the other. When this view is adopted it becomes

impossible to conduct the process reversibly in such a manner as to deliver work to one extraneous body and to receive heat from another. Yet the change of state of B can be conducted reversibly by utilizing apparatus that itself constitutes a part of the whole earth. Let a reversible lowering of the ball transmit work w to a mechanism M . Then let a sufficient mass of some gas be confined in a cylinder by a frictionless piston, and let the heat capacity of the cylinder and piston be negligibly small. On placing the cylinder in contact with B , reversible compression of the gas G transfers heat w to B and raises the common temperature of B and G from θ_0 to θ_1 . The entropy of B rises, and the entropy of G falls by the same amount. If the change of energy of G is δe , the gas absorbs work $w + \delta e$, which may be supposed supplied by M . Now let the energy of G be restored to its initial value by reversible adiabatic expansion or compression of G , whereby the work δe is transferred to M . This restores M to its initial state. The net result is that the entropy of the world is unaltered, and that the state of the world is that originally resulting from the irreversible fall of the ball, together with an outstanding decrease of the entropy of G while the energy of G remains unchanged. In the *irreversible* process the increase of the entropy of B occurred, but the decrease of the entropy of G did not. In the irreversible process the change of the entropy of the world as a whole was positive.

2. *Friction*. When a mechanism expends work in rubbing two bodies together, the temperature of the bodies rises. If this change of state of mechanism and bodies were conducted on a reversible path, the mechanism would develop work and a quantity of heat equal to this work would be added to the bodies. In the irreversible process, therefore, the change of the entropy of the whole contrivance was positive. The energy that could have been developed as work was dissipated in producing a heating effect. If the mechanism were replaced by a falling weight, the earth would become one of the participating bodies, exactly as in the preceding example.

3. *Temperature Equalization*. When two metal blocks having different uniform temperatures θ_1 and θ_2 , where $\theta_2 > \theta_1$, are brought into contact, their temperatures attain a common inter-

mediate value θ_i . This irreversible adiabatic process of temperature equalization can be conducted reversibly as follows. A body of gas at the temperature θ_7 and in contact with the hot block, but otherwise thermally insulated, is reversibly expanded on the path a_1a_2 of Fig. 30 until the common temperature of the gas and the block has fallen to say θ_6 . Then adiabatic expansion on the path a_2a_3 brings the temperature of the gas to θ_1 ; when compression on the path a_3a_4 in contact

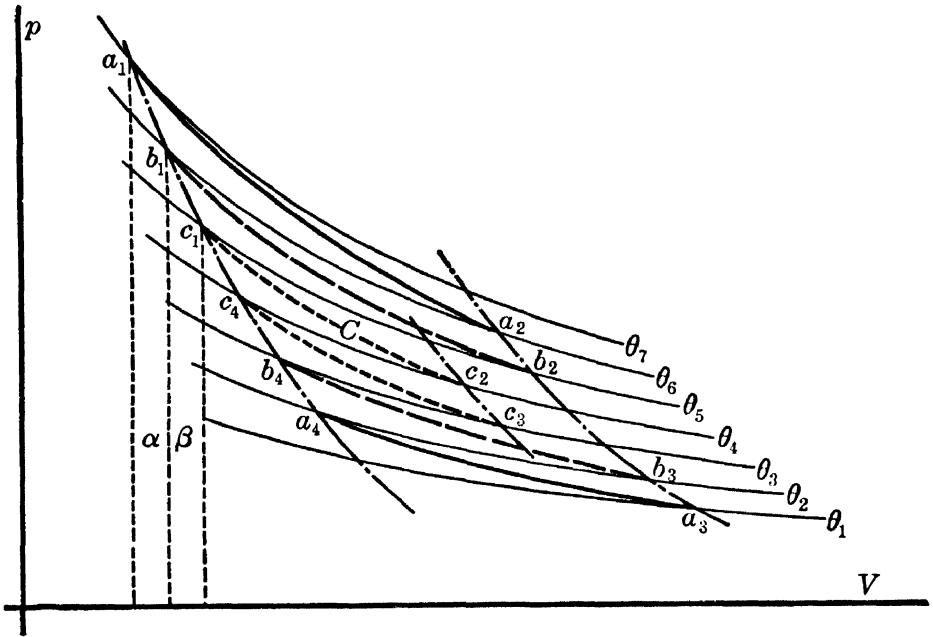

FIG. 30

with the cold block raises the temperature of this block to θ_2 ; whereupon adiabatic compression restores the gas to its initial state. To continue the process, adiabatic expansion a_1b_1 , with development of work α , brings the temperature of the gas to θ_6 , whereupon the cycle $b_1b_2b_3b_4$ brings the temperatures of the blocks to θ_5 and θ_3 . Then expansion b_1c_1 , developing work β , and execution of the cycle $c_1c_2c_3c_4$, brings the temperatures of the blocks to the common value θ_4 , whereupon the compression c_1a_1 absorbs the work $\alpha + \beta$ and restores the gas to its initial state. The temperature equalization has been reversibly conducted, and has supplemented an absorption of work equal to the sum of the areas of the three cycles in the V, p plane.

When the temperature of the hot block is thus reduced to θ_i , some of the heat developed by this block has been converted into work, and only the remainder has been transmitted to the cold block. Hence, in order to complete the reversible equalization of the temperatures, the succession of cycles must be continued, with a further development of work and the attainment of a common temperature lower than θ_i . Hence the final temperature θ_f of the blocks can be reversibly attained only by addition of a quantity of heat equal to the work that has been developed. In the irreversible temperature equalization, therefore, the change of the entropy of the blocks was positive. The energy that could have been developed as work was dissipated in producing a heating effect.

4. *Expansion.* When a body of gas expands abruptly into an exhausted receiver, its final temperature may be either less than, equal to, or greater than its initial temperature. Since the process occurs at constant energy, the initial and final states lie on the same isodynamic curve, and we may seek to formulate the rate of change of the temperature on this curve. If e , v , s are the specific energy, volume, and entropy of the gas under the pressure p at the temperature θ , the differential of the specific energy is

$$de = -pdv + \theta ds,$$

or, in the independent variables v , θ ,

$$de = \left(-p + \theta \frac{\partial s}{\partial v}\right)dv + \theta \frac{\partial s}{\partial \theta} d\theta.$$

If we eliminate $\partial s / \partial v$ between this equation and the condition of integrability

$$-\frac{\partial p}{\partial \theta} + \frac{\partial s}{\partial v} = 0,$$

and note that $\theta \cdot \partial s / \partial \theta$ is the specific heat c_v at constant volume, we obtain

$$de = \theta^2 \frac{\partial}{\partial \theta} \frac{p}{\theta} dv + c_v d\theta;$$

whence follows that the rate of change of the temperature of the gas in isodynamic expansion is

$$\left(\frac{\partial \theta}{\partial v}\right)_e = -\frac{\theta^2}{c_v} \frac{\partial}{\partial \theta} \frac{p}{\theta}.$$

Since θ and c_v are positive, it follows that the temperature of the gas falls on expansion into a vacuum when the condition

$$\left(\frac{\partial}{\partial \theta}\right)_v \frac{p}{\theta} > 0$$

is satisfied, and that it rises when the sign of inequality is reversed.

When the adiabatic expansion $v_b - v_a$ is conducted reversibly at constant entropy s_a , as indicated in Figs. 31 and 32, by

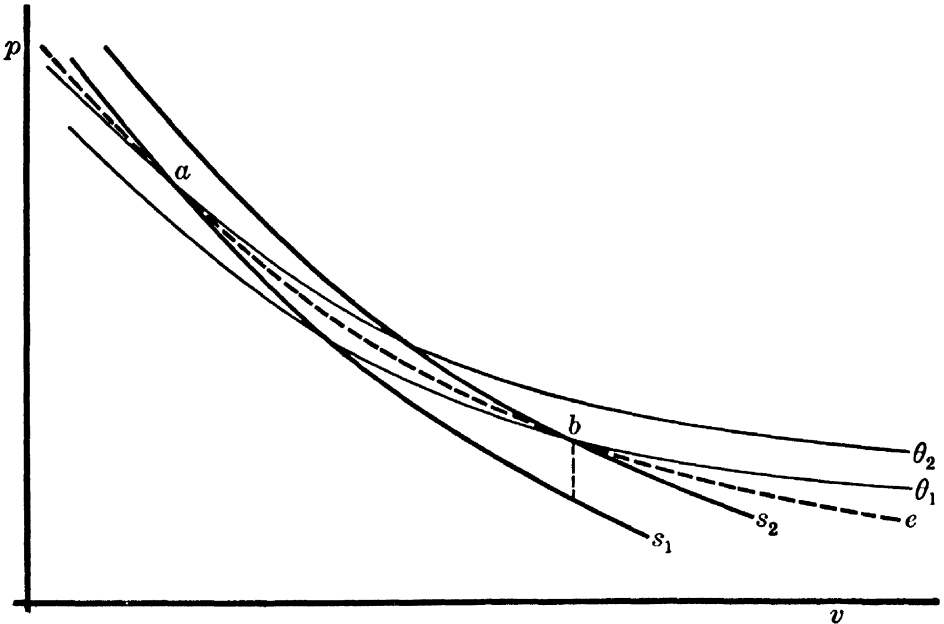

FIG. 31

expansion behind a piston against a pressure equal to p , work is developed at the expense of the energy of the gas, wherefore the final temperature is lower than before. Hence the final state of the irreversible expansion can be reversibly attained only by addition of a quantity of heat equal to the work developed. In the irreversible expansion the change of the entropy of the gas was positive. The energy that could have been developed as work was dissipated in producing a heating effect. This is true even in the first case, in which a *cooling* occurs.

5. *Compression.* Let a body of gas be confined in a horizontal cylinder by a piston acted on by a strong spring. On releasing the spring, irreversible adiabatic compression of the gas ensues

until the force exerted by the spring is counterbalanced by that due to the pressure of the gas. It is assumed that no sensible transfer of heat from the gas to the cylinder and piston occurs.

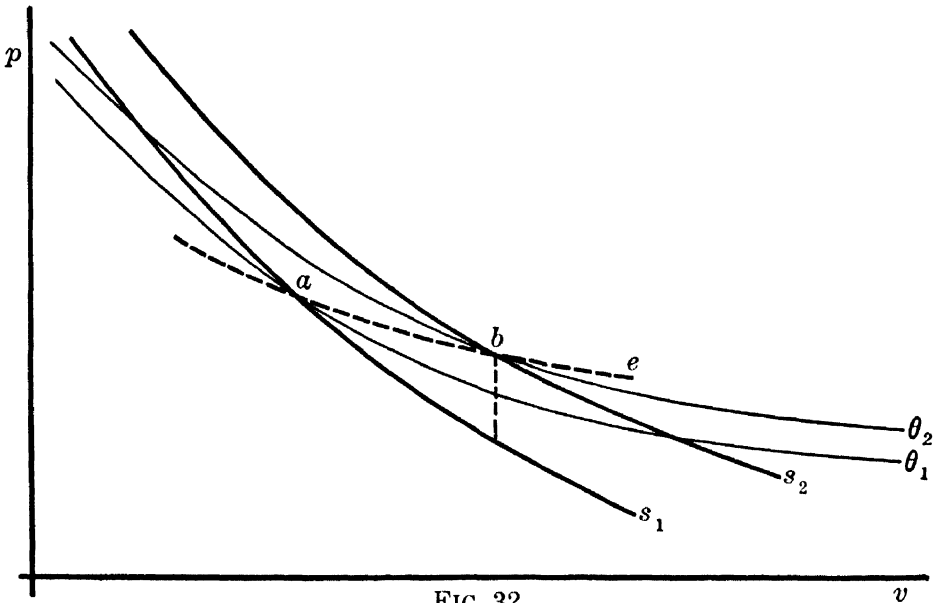

FIG. 32

When the adiabatic compression is conducted reversibly at constant entropy s_a , as indicated in Fig. 33, work is developed

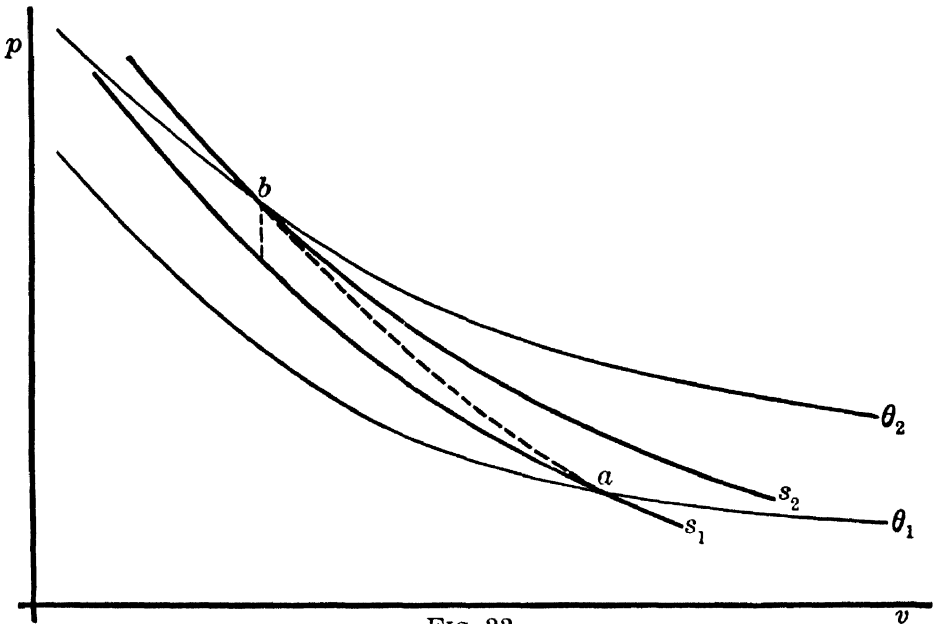

FIG. 33

at the expense of the energy of the spring. The energy of the gas is now less, by the amount of this work, than it was at the close of the irreversible compression. Hence the final state of the irreversible compression can be reversibly attained only by addition of a quantity of heat equal to the work developed. In the irreversible compression the change of the entropy of the gas was positive. The energy that could have been developed as work was dissipated in producing a heating effect. If the spring were replaced by a falling weight, the earth would become one of the participating bodies, as in the first example discussed.

6. *Diffusion.* The adiabatic dilution of an aqueous solution of cane sugar by a body of liquid water can be effected reversibly when the solution and the water, contained in a horizontal cylinder, are separated by a piston permeable only by the water. For then the tendency of the liquids to mix can be counterbalanced by a force applied to the piston. When the dilution is effected reversibly, work is gained and the energy of the whole body of liquid is decreased by the amount of this work. Hence the final state of the irreversible dilution can be reversibly attained only by addition of a quantity of heat equal to the work developed. In the irreversible dilution the change of the entropy of the liquids was positive. The energy that could have been developed as work was dissipated in producing a heating effect.

The foregoing description, in exactly the same words, would apply to a similar dilution of a solution of potassium sulphocyanate, although this dilution results in a cooling; that is, in a considerable fall of the temperature of the liquids.

7. *Chemical Reaction.* The explosive union of chemically equivalent masses of hydrogen and oxygen is an irreversible adiabatic process. When the reaction is effected reversibly in the operation of a "gas cell," work may be gained by the action of the electric current developed. To complete the reversible process, the energy thus lost must be restored by addition of heat to the water formed. The conclusion to be drawn is the same as in the preceding examples.

Uncontrollable Processes. Thermodynamic processes of the type of the examples thus far considered form a large class. All

such processes are irreversible adiabatic changes of state occurring at constant energy of the bodies concerned. Each is capable of being conducted under complete control along a segment of path on which it develops work alone, followed by a segment of path on which it absorbs heat equal to this work. In the actually occurring process, the energy reversibly obtainable as work is dissipated in producing a heating effect. This dissipation being a maximum, the body attains the state in which it has the greatest entropy compatible with its energy.

But cases occur in which it is not evident that the irreversible process can be checked and brought under control by opposing forces. An example is supplied by the spontaneous formation of ice in supercooled water. Let a thermally insulated rigid shell contain the supercooled water, and vapor in equilibrium with it, and let the freezing of a part of the water bring the temperature of the enclosed body to the freezing temperature θ_0 of water in equilibrium with its vapor. The process is uncontrollable. But the change of state can be conducted under control by: (a) reversibly adding heat q to bring the temperature of the body to θ_0 , and (b) reversibly forming ice by isothermal abstraction of the heat q . On the path a the increase of entropy $\int Dq/\theta$ of the body is equal to a ratio q/θ_1 , where θ_1 is a temperature less than θ_0 . On the consecutive paths a and b , therefore, the change of entropy of the body is

$$\frac{q}{\theta_1} - \frac{q}{\theta_0},$$

which again is a positive quantity.

A more difficult example is afforded by the formation of solid ammonium chloride, with a little vapor, from separate chemically equivalent masses of gaseous ammonia and hydrochloric acid contained in a thermally insulated rigid shell. It is not evident that this irreversible process can be conducted on a reversible path. Yet such an operation can perhaps be imagined. Let the separated gases be reversibly expanded and heated until they reach a pressure and temperature at which the vapor of ammonium chloride would be completely dissociated into its components. Then let the gases be reversibly mixed with the

aid of a piston permeable by only one of the components. Hereupon let the initial volume and temperature be attained by reversible compression and cooling. And, finally, let a reversible addition of a quantity of heat, equal to the work that has been developed, bring the body to the final state that was attained in the irreversible process originally contemplated. If the possibility of this reversible operation be granted, it will have been shown that the irreversible formation of ammonium chloride is a dissipative process. But the assumptions on which the conclusion rests are too doubtful to be taken seriously. And chemical processes that are more intractable than this one can be readily cited. That all of them are dissipative is generally believed; but it is not clear that conclusive grounds for this belief can be given.

The Postulate of Dissipation. The foregoing survey suggests a distinction between irreversible processes that are known to admit a reversible path and those that are not. The class of processes that admit a reversible path is very extensive. It includes the destruction of work by impact or friction, and it includes heat conduction, expansion or compression of elastic bodies, diffusion, crystallization of supercooled liquids, and some chemical reactions. When any change of state of this class is conducted under control it develops work against the controlling forces, wherefore the energy lost as work must be restored as heat when the change of state is completed on a reversible path. Since this addition of heat increases the entropy of the set of bodies undergoing the process, it follows that the irreversible change proceeds in the direction permitting the greatest possible increase of the entropy of the set. This is merely a way of saying that the irreversible process follows the path of least resistance, or of the greatest possible avoidance of doing work. It is a way of saying that work which the process could be compelled to develop is dissipated in producing a heating effect. When the process involves a cooling, as in the expansion of a fluid for which

$$\frac{\partial}{\partial \theta} \frac{p(v, \theta)}{\theta} > 0,$$

or in a dilution for which the heat of dilution is negative, the cooling is less than that which occurs when the adiabatic change of state is conducted reversibly.

In the case in which an irreversible process is not known to admit a reversible path, no such conclusion as the foregoing can be drawn. For the process cannot be shown to be dissipative if work cannot be gained by conducting it under control. And nothing can be known of the corresponding change of entropy, since this is defined only with reference to a reversible path.

The inductively reached conclusion, that all thermodynamic processes capable of being conducted reversibly are dissipative, may be postulated in the following terms :

Postulate. When a thermally and dynamically isolated body undergoes a change of state that admits of a reversible path, the change of the entropy of the body is positive.

This postulate will be termed the *dissipation law*. It determines the conditions of stability of thermodynamic equilibria.

It is of interest to observe that the entropy of a body of gas in a state of stable thermodynamic equilibrium at constant volume and energy is a maximum. If two parts of the gas are separated by a thermally non-conducting wall, it is obvious that the entropy is decreased when a quantity of heat is added to one of the parts and is abstracted from the other. And it is obvious that the entropy is decreased when the separating wall is displaced, and the gain of energy by the work of compression is removed by abstraction of heat.

Thermally Isolated Bodies. *Partial Dissipation.* Any dissipative process, considered as a whole, is adiabatic and isodynamic. But a given separate body may undergo a dissipative adiabatic process in the course of which it transfers work to other bodies. The change of state of the body composed of all the participating bodies is still adiabatic and isodynamic ; but the change of state of the given body is not isodynamic. The given body develops some work, and dissipates some energy. The less work it develops the more energy it dissipates. *An adiabatic change*

of the state of a body is more or less dissipative according as the body more or less escapes development of work.

Consider a few illustrative cases. The free fall of a heavy ball into a thermally insulated receptacle is wholly dissipative; when the falling ball raises a lighter ball, by a cord passing over a pulley, the process is partly dissipative; when both balls have the same weight and the cord operates without friction the (limiting) process is a set of states of equilibrium and is non-dissipative. Adiabatic expansion of an elastic body into a vacuum is wholly dissipative; when the adiabatic expansion occurs against an opposing pressure it is partly dissipative; when it is supposed conducted against an exactly counterbalancing pressure it is a set of states of equilibrium and is non-dissipative. Unhampered adiabatic equalization of the initially different temperatures of two metal blocks is wholly dissipative; when the adiabatic equalization occurs with intervention of a succession of cyclical operations it is partly dissipative; when it is supposed conducted reversibly it is a set of states of equilibrium and is non-dissipative.

It is clear that the set of the possible adiabatic changes of state of a body has two limiting paths. One is the path of the wholly dissipative process, which occurs at constant *energy* of the body. The other is the path of the non-dissipative process, which occurs at constant *entropy* of the body. An adiabatic path is isodynamic only when the process is wholly dissipative, and it is isentropic only when the process is non-dissipative.

An Illustration. To illustrate the matter in more detail, let a region of the states of equilibrium of an elastic body, such as a mass of gas or a mass of coexistent liquid and vapor, be represented by the points of an area in the volume-pressure diagram of Fig. 34. Let the point *a* represent the initial state of the body, and let the lines *s*₁, *e* be the isentropic and the isodynamic passing through the point. In the wholly dissipative adiabatic expansion from *v*₁ to *v*₂, the final state of the body is represented by the point *b*. The entropy of the body becomes *s*₂ > *s*₁. The intermediate states, being turbulent states, are not represented by points on the line *ab*; for only states of equilibrium are

represented by points in the diagram. In the non-dissipative adiabatic expansion from v_1 to v_2 , the final state of the body is represented by the point b' . In this case the intermediate states are represented by the points of the line ab' ; for all are states of equilibrium. The process is a limiting one. Partly dissipative adiabatic expansions lead to final states represented by points on the line $b'b$; and here again the intermediate states are not represented by points in the diagram. Because of the

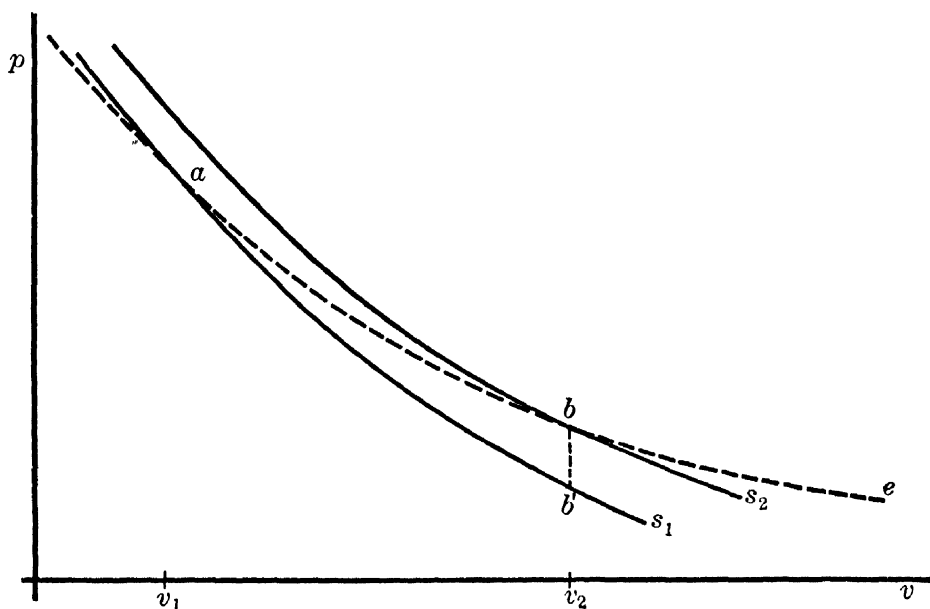

FIG. 34

dissipation actually occurring, the states attained are such that the entropy determined by any one of them exceeds s_1 .

Synopsis. Every actually occurring change of the thermodynamic state of a body or of a set of bodies proceeds of itself, in a definite direction, and on an irreversible path. The entire process is a change of state of a thermally and dynamically isolated body, and so is adiabatic and isodynamic. Examination of a diversity of such processes suggests a distinction between irreversible processes that are known to admit a reversible path and those that are not. And it indicates that a process conducted under control develops work against the controlling forces, wherefore the energy lost as work must be restored as

heat when the change of state is completed on a reversible path. The conclusion that the uncontrolled process follows the path of least resistance, and that the work which it could be compelled to develop is dissipated in producing a heating effect, is formulated by the postulate of the *dissipation law* :

When a thermally and dynamically isolated body undergoes a change of state that admits of a reversible path, the change of the entropy of the body is positive.

When a thermally isolated body develops work in an actual process, the change of state is more or less dissipative according as the body more or less escapes development of work. When the adiabatic process is wholly dissipative it is isodynamic; when it is non-dissipative it is isentropic.

CHAPTER XIV

A CRITERION OF STABILITY

An Application of the Dissipation Law. It will now be sought to apply the dissipation law, to establish a criterion of the stability of the thermodynamic equilibrium of a body subjected to an imposed uniform and normally directed constant pressure p at an imposed uniform constant temperature θ . If the body is not constituted of parts separated in space, it can be supposed enclosed by a rigid and thermally non-conducting envelope. We shall suppose it to be so enclosed, and to be initially in any state satisfying the conditions that it is not a state of stable equilibrium under the pressure p at the temperature θ , and that it can be transformed into a state of stable equilibrium at p, θ by processes subject to control. We shall first allow to occur any possible dissipative change of state of the enclosed body. This process will consist of such happenings as equalization of unbalanced forces, equalization of different temperatures, evaporation, diffusion, and the like. It will cause the entropy of the body to increase by an amount Σ_1 , and it will cause the temperature of the body to attain a uniform value θ_1 . We shall now suppose the enclosed body B to be suspended in a gas G of such extent that the operations to be described will not sensibly alter the uniform pressure p and temperature θ of the gas. The total volume of the body BG composed of B and G shall be supposed held constant by means of a rigid and thermally non-conducting case enclosing both. To ensure uniformity of the pressure p , it must be assumed that the influence of gravity on the bodies B and G can be neglected.

If $\theta_1 \neq \theta$, equalization of the temperatures of B and G can be effected by the agency of a reversible cyclical change of state of an auxiliary gas, whereby a quantity of work w_2 is developed at the expense of the energy of BG . If we now establish thermal communication between B and G , reversible addition of heat

w_2 to BG returns the energy of this body to its initial value, and increases the entropy of BG by the amount $w_2/\theta = \Sigma_2$. The enclosed body B is now in thermal equilibrium with G , but the pressures on the two sides of the enclosing envelope are not necessarily equal. On reversibly equalizing these pressures, heat flows from one of the bodies to the other without altering the entropy of both, and a quantity of work w_3 is developed at the expense of the energy of both. Reversible addition of heat w_3 to BG then returns this energy to its initial value, and increases the entropy of BG by the amount $w_3/\theta = \Sigma_3$. The state of the body B is now a state of stable equilibrium under the imposed pressure and temperature p, θ . In the process through which this state has been attained, the body B has passed from any state that is not a state of stable equilibrium under the pressure p at the temperature θ (though transformable into such a state by processes subject to control) to a state whose equilibrium is stable under these conditions; and in this process the entropy of the body BG has increased by an amount

$$\Sigma_1 + \Sigma_2 + \Sigma_3 = \Sigma.$$

A Criterion of Stability. Now let the initial volume, entropy, and energy of B be V_1, S_1, E_1 , let the final values of these quantities be V_0, S_0, E_0 , and let the initial and final values of the volume, entropy, and energy of G be v_1, s_1, e_1 , and v_0, s_0, e_0 , respectively. Since the change of state of G was reversible, we have, by the energy and entropy laws,

$$de = -pdv + \theta ds;$$

whence, since p, θ are constants, it follows that

$$e_0 - e_1 = -p(v_0 - v_1) + \theta(s_0 - s_1);$$

or, rearranging terms,

$$e_0 + pv_0 - \theta s_0 = e_1 + pv_1 - \theta s_1. \quad (44)$$

In the entire process the energy and volume of BG remained unaltered, while the entropy of this body increased by an amount Σ ,

$$e_0 + E_0 = e_1 + E_1, \quad (45)$$

$$v_0 + V_0 = v_1 + V_1, \quad (46)$$

$$s_0 + S_0 = s_1 + S_1 + \Sigma. \quad (47)$$

Rewriting these equations, multiplying (45), (46), (47) by -1 , $-p$, and θ respectively, we have

$$\begin{aligned} e_0 + pv_0 - \theta s_0 &= e_1 + pv_1 - \theta s_1, \\ -e_0 - E_0 &= -e_1 - E_1, \\ -pv_0 - pV_0 &= -pv_1 - pV_1, \\ \theta s_0 + \theta S_0 &= \theta s_1 + \theta S_1 + \theta \Sigma; \end{aligned}$$

whence, by addition,

$$-E_0 - pV_0 + \theta S_0 = -E_1 - pV_1 + \theta S_1 + \theta \Sigma;$$

or, rearranging,

$$(E_1 - E_0) + p(V_1 - V_0) - \theta(S_1 - S_0) = \theta \Sigma. \quad (48)$$

Apart from the positive quantity $\theta \Sigma$, this equation involves only quantities relating to the end states of the body B . If the stable state (V_0, S_0, E_0) of B is a state of a continuous region of states all of which are stable under the pressure p at the temperature θ , any other state of the region can be attained from the state (V_0, S_0, E_0) by reversible expansion or contraction and heating or cooling of B . In this process work developed by either B or G is absorbed by the other, and heat developed by either is absorbed by the other, wherefore the energy and entropy of BG remain constant. In this process $\Sigma = 0$. Now, when the operator δ relates to the variation of the state of B from any state of stable equilibrium under the pressure p at the temperature θ to any state whose equilibrium is not stable under these conditions, we have by (48)

$$\delta E + p\delta V - \theta\delta S > 0;$$

and when δ relates to a variation of state within a region of states whose equilibrium is stable at p, θ we have

$$\delta E + p\delta V - \theta\delta S = 0.$$

It thus appears that a body supporting the uniform and normally directed pressure p at the temperature θ is in a state of stable equilibrium if all possible sets of variations $\delta E, \delta V, \delta S$ of the energy, volume, and entropy of the body satisfy the *criterion of stability*,

$$\delta E + p\delta V - \theta\delta S \geq 0. \quad (49)$$

In this application of the dissipation law the quantities p and θ are the *constant* pressure and temperature of the given state. It is important to comprehend that, in the formulation

$$\delta E \cong - p\delta V + \theta\delta S,$$

as it is often written, the quantities p, θ are *constants*, and that the finite differences $\delta V, \delta S, \delta E$ are *not* differentials. When the variation of state occurs within a region of states whose equilibrium is stable under the imposed conditions, the sign of equality obtains. In all other cases the sign of inequality obtains.

Synopsis. Let any body B , subject to no force other than a uniform and normally directed pressure, be given in a state which is not a state of stable equilibrium under the arbitrary imposed pressure p and temperature θ , but which can be transformed into such a state by processes subject to control. Let B be enclosed in a rigid and thermally non-conducting shell suspended in a body G of gas having the sensibly constant pressure p and temperature θ .

Then any possible dissipative changes of the state of B , followed by reversible equalization of the temperatures, and then of the pressures, of B and G , increase the entropy of B and G by an amount Σ , and thus bring G from (e_1, v_1, s_1) to a state (e_0, v_0, s_0) , and bring B from (E_1, V_1, S_1) to a state (E_0, V_0, S_0) whose equilibrium is stable under the imposed conditions. Since the change of state of G is reversible, it follows that

$$e_0 + pv_0 - \theta s_0 = e_1 + pv_1 - \theta s_1.$$

Further, the total energy and the total volume of BG are unaltered, while the entropy of this body has increased by Σ ,

$$e_0 + E_0 = e_1 + E_1,$$

$$v_0 + V_0 = v_1 + V_1,$$

$$s_0 + S_0 = s_1 + S_1 + \Sigma.$$

From these four equations it follows that

$$(E_1 - E_0) + p(V_1 - V_0) - \theta(S_1 - S_0) = \theta\Sigma. \quad (48)$$

When the state of B is displaced from any state (E_0, V_0, S_0) of stable equilibrium at p, θ to any other state (E_1, V_1, S_1) , the

quantity $\theta\Sigma$ in (48) is equal to zero when the displacement occurs in a continuous region of states whose equilibrium is stable at p, θ , and it is positive in all other cases. It follows that a body supporting the uniform and normally directed pressure p at the temperature θ is in a state of stable equilibrium if all possible sets of variations $\delta V, \delta S, \delta E$ of the volume, entropy, and energy of the body satisfy the criterion of stability,

$$\delta E + p\delta V - \theta\delta S \cong 0,$$

where the quantities p, θ are the *constant* pressure and temperature of the given state. When the variation of state occurs within a continuous region of states whose equilibrium is stable under the imposed conditions, the sign of equality obtains. In all other cases the sign of inequality obtains.

CHAPTER XV

REVIEW

Definitions. The chain of reasoning exhibited in the foregoing text will now be summarized. The preliminary explanation of the meanings to be attached to the terms *body*, *temperature*, *quantity of heat*, *thermodynamic state*, *change of state*, *path of change of state*, *supplementary changes of state*, *state of thermodynamic equilibrium*, and *regions of states of thermodynamic equilibrium*, need not be repeated.

Energy. The experimental fact that the algebraic sum of the work W_{ab} and heat Q_{ab} absorbed by a body in any change ab of its thermodynamic state is independent of the path of the change of state is the *first law* of thermodynamics. From this law it follows that the sum in question is equal to the concurrent change of the value of a single-valued continuous function E of the variables that determine the state of the body,

$$E_b - E_a = W_{ab} + Q_{ab}.$$

This equation expresses the *energy law*. The work and the heat absorbed vary in general with the path of the change of state.

Reversibility. When a continuous one-dimensional set of states of thermodynamic equilibrium connecting states a and b of a body is the limit approached by a family of paths of the change of state ab , and also by a family of paths of the reversed change of state ba , when these changes of state are conducted with extreme slowness under the influence of the independently controlled imposed forces and temperature, the set is termed a *reversible path* of either change of state. Any reversible cyclic thermodynamic process conducted on an isothermal path followed successively by an adiabatic, an isothermal, and a concluding adiabatic path, is a *Carnot cycle*. Let the i th cycle

of a set of Carnot cycles absorb heat x_i at a temperature t_{i1} , operate between temperatures t_{i1} and t_{i2} , and develop heat Q_i at t_{i2} , where $i = 1, 2, \dots, n$. Then, when $n = 1$, and when $n > 1$ and the conditions

$$t_{i1} = t_{i-1, 2}, \quad x_i = Q_{i-1}, \quad i = 2, 3, \dots, n,$$

are satisfied, the set of cycles is a *sequence*. When a sequence absorbs heat x at the first terminal temperature, develops heat Q at the last one, and absorbs work W , these quantities are connected by the relation

$$x + W = Q.$$

The Second Law. The postulates, that a change of state consisting of a development of heat cannot supplement a change of state consisting of an absorption of work, and that an un-supplemented transfer of heat from a cooler body to a warmer one is impossible, constitute the *second law* of thermodynamics.

The Function W . Let any sequence absorb heat x at a temperature t_1 , operate between temperatures t_1 and t_2 , absorb work W , and develop heat Q at t_2 . Then it follows from the two laws of thermodynamics that when $x \neq 0$ and $t_2 > t_1$ the quantities x, W, Q have the same sign; and that when $x = 0$ these quantities all vanish, irrespective of whether t_2 is greater than, equal to, or less than t_1 .

It also follows that W is independent of the nature of the working bodies employed in the operation of the sequence, and that it always has the same value for a given set of values of x, t_1, t_2 . Hence, when W is assumed to be continuous, *the work W is a single-valued continuous function $W(x, t_1, t_2)$ of the independent x, t_1, t_2 ; and $W(x, t_1, t_2) = 0$ for $t_2 = t_1$.*

Dependence of W on x . When x and ξ are arbitrary quantities of heat, it also follows that

$$W(x) + W(\xi) = W(x + \xi);$$

and hence that the form of dependence of W on x is expressed by the identity

$$W(x, t_1, t_2) = W(1, t_1, t_2)x.$$

On eliminating W between this and the equation $x + W = Q$, we obtain

$$Q = [1 + W(1, t_1, t_2)]x.$$

It thus appears that the ratios W/x and Q/x are single-valued continuous functions of t_1, t_2 . This result includes the *theorem of Carnot*, that the efficiency of a Carnot cycle is a function solely of the temperatures between which the cycle operates.

Dependence of W on t_1, t_2 . It remains to investigate the form of dependence of $W(1, t_1, t_2)$ on t_1, t_2 . If we give an arbitrary increment $t_3 - t_2$ to the interval $t_2 - t_1$ through which any sequence operates, the function $W(1, t_1, t_2)$ receives an increment

$$W(1, t_1, t_3) - W(1, t_1, t_2) = W[1 + W(1, t_1, t_2), t_2, t_3];$$

or, if we factor the heat-absorption out of the last term and rearrange,

$$1 + W(1, t_1, t_3) = [1 + W(1, t_1, t_2)][1 + W(1, t_2, t_3)];$$

or
$$q(t_1, t_3) = q(t_1, t_2)q(t_2, t_3), \tag{12}$$

when we define a function q by

$$q(t_i, t_j) = Q(1, t_i, t_j) = 1 + W(1, t_i, t_j).$$

Now, since $W(1, t_1, t_2) = 0$ for $t_2 = t_1$, we have that $q(t_1, t_2) = 1$ for $t_2 = t_1$, wherefore we obtain from (12) that

$$q(t_1, t_2)q(t_2, t_1) = 1. \tag{14}$$

Further, because of the theorems that when $x \neq 0$ and $t_2 > t_1$, the quantities x, W have the same sign, and that $W = 0$ for $t_2 = t_1$, we find that

$$\begin{aligned} t_2 < t_1, & \quad 0 < q(t_1, t_2) < 1; \\ t_2 = t_1, & \quad q(t_1, t_2) = 1; \\ t_2 > t_1, & \quad q(t_1, t_2) > 1. \end{aligned} \tag{15}$$

If now in (12) we put $t_2 = a$, and then put $t_3 = t_2$, and apply (14), we obtain

$$q(t_1, t_2) = q(t_1, a)q(a, t_2) = \frac{q(a, t_2)}{q(a, t_1)} = \frac{\theta(t_2)}{\theta(t_1)}.$$

Here $\theta(t)$, since it is equal to $q(a, t)$, is positive by (15). Again, since $q(t_1, t_2) > 1$ for $t_2 > t_1$, it appears that

$$\frac{\theta(t_2)}{\theta(t_1)} > 1, \quad t_2 > t_1,$$

that is, that θ is an increasing function. Thus θ is a positive, increasing, single-valued, continuous function of t .

Finally, from

$$W = W(1, t_1, t_2)x = [q(t_1, t_2) - 1]x = \left(\frac{\theta(t_2)}{\theta(t_1)} - 1\right)x,$$

we find that the form of W is expressed by the identity

$$W(x, t_1, t_2) = \frac{\theta(t_2) - \theta(t_1)}{\theta(t_1)} x.$$

Absolute Temperature. When a temperature of reference t_r is the "ice point," and we put $t_1 = t_r$ and $t_2 = t$, we now have the successive equations

$$\frac{Q}{x_r} = 1 + W(1, t_r, t) = q(t_r, t) = \frac{\theta(t)}{\theta(t_r)}. \quad (20 b)$$

Since the ratio Q/x_r is independent of the nature of the body developing the heat Q at the general temperature t , it is employed to define the ratio of an "absolute" temperature $\theta(t)$ to its arbitrary value $\theta(t_r)$ at the temperature of reference t_r .

To fix the arbitrary constant $\theta(t_r)$, let Δ units be assigned to the change of θ between t_r and the "boiling point" t_s ,

$$\theta(t_s) - \theta(t_r) = \Delta.$$

Then, on equating the second and fourth members of (20 b) for $t = t_s$,

$$\frac{\theta(t_s)}{\theta(t_r)} = 1 + W(1, t_r, t_s) = 1 + W_{rs},$$

and on eliminating $\theta(t_s)$ between these two equations, we find

$$\theta(t_r) = \frac{\Delta}{W_{rs}}.$$

Substitution of this value in the last equation of (20 b) gives

$$\theta = \frac{\Delta}{W_{rs}} \cdot q(t_r, t).$$

For positive Δ , this equation defines the absolute temperature θ of any body having the uniform temperature t , by a positive, increasing, single-valued, continuous function of t .

A Theorem on Carnot Cycles. Since the function $q(t_1, t_2)$ is equal to Q/x , and has the form $\theta(t_2)/\theta(t_1)$, we have

$$\frac{Q}{x} = \frac{\theta(t_2)}{\theta(t_1)}.$$

If $Q_1 = x$ and $Q_2 = -Q$ are the quantities of heat *absorbed* by the working body in the operation of any Carnot cycle, it thus appears that Q_1, Q_2, t_1, t_2 are connected by the relation

$$\frac{Q_1}{\theta(t_1)} + \frac{Q_2}{\theta(t_2)} = 0. \tag{23}$$

The heat-element of a selected auxiliary body of homogeneous fluid is the expression $DQ = dE + pdV$. Dividing this expression by θ , and integrating it along the contour of any Carnot cycle in the V, t plane, we obtain (23) in the form

$$\int_{CC} \frac{DQ}{\theta} = \int_{CC} \left[\frac{1}{\theta} \left(\frac{\partial E}{\partial V} + p \right) dV + \frac{1}{\theta} \frac{\partial E}{\partial t} dt \right] = 0. \tag{25}$$

Now, applying Green's theorem to the line integral of the same expression taken along *any* closed contour C in the V, t plane,

$$\int_C \left[\frac{1}{\theta} \left(\frac{\partial E}{\partial V} + p \right) dV + \frac{1}{\theta} \frac{\partial E}{\partial t} dt \right] = \iint \frac{1}{\theta} \left[\left(\frac{\partial E}{\partial V} + p \right) \frac{1}{\theta} \frac{d\theta}{dt} - \frac{\partial p}{\partial t} \right] dV dt.$$

But the integrand of the surface integral cannot be positive (or negative) at all the points of any subregion R_1 , else the line integral taken along the contour of a Carnot cycle within R_1 would be positive (or negative), in conflict with (25). Hence the line integral of the expression DQ/θ , taken along any closed contour C in the plane, is equal to zero,

$$\int_C \frac{DQ}{\theta(t)} = 0.$$

Entropy. If the work-element for any body B , in any region R_i of its states of equilibrium, is a linear expression DW_i in the regional variables, it follows that the heat-element for the region is a linear expression DQ_i in these variables. Both expressions are in general inexact.

By coupling a mechanism M with *any* body B and with an auxiliary body G of gas in thermal equilibrium with B , it may

be shown (by means of the second law) that *any* possible reversible cyclic change of the thermodynamic state of B can be associated with a reversible cyclic change of the state of G in such a manner that all heat developed by either body is absorbed by the other.

If the cyclic path C of the change of state of B lies in a region R_i of states, we thus find that

$$\int_C \frac{DQ_i}{\theta(t)} = 0. \quad (33)$$

It follows that the integrand in (33) is the differential of a continuous function S_i of the regional variables,

$$\frac{DQ_i}{\theta(t)} = dS_i. \quad (34)$$

Since the function S_i is defined by its differential, it contains an arbitrary additive constant. To provide this constant, the quantity S_i at the general state σ of the general region R_i is defined with reference to a state of reference ρ in a region R_0 . If any reversible path of the change of state $\rho\sigma$ traverses successive regions R_0, R_a, \dots, R_i , the quantity S_i at the state σ is defined by integration along the path,

$$S_i = \int_{\rho} \frac{DQ_0}{\theta} + \int \frac{DQ_a}{\theta} + \dots + \int^{\sigma} \frac{DQ_i}{\theta}.$$

The quantity so defined is independent of the path. For the sum $S'_i - S''_i$ obtained by integrating along a cyclic path composed of any path of the change of state $\rho\sigma$, followed by any other path of the change $\sigma\rho$, is equal to zero. The single-valued continuous function S_i is the *entropy* of the body B for the region R_i . The theorem that the ratio of any regional heat-element to the absolute temperature is the differential of a single-valued continuous function having continuous first derivatives is the *entropy law*.

From (34) it appears that any regional heat-element DQ_i has the formulation

$$DQ_i = \theta dS_i,$$

where θdS_i is in general inexact. In an isothermal region the expression is exact. The absolute temperature is the only integrating divisor of DQ_i , that is a function of t alone.

Scale of Absolute Temperatures. The form of the function $\theta(t)$ can be most accurately determined by means of the "porous plug effect,"

$$\psi = \left(\frac{\partial t}{\partial p} \right)_{e+pv}.$$

$$\text{From } d(e + pv) = vdp + \theta ds = \left(v + \theta \frac{\partial s}{\partial p} \right) dp + \theta \frac{\partial s}{\partial t} dt,$$

we find the condition of integrability of the last member, and a formulation of the porous plug effect,

$$\frac{\partial v}{\partial t} + \frac{d\theta}{dt} \frac{\partial s}{\partial p} = 0, \quad \left(\frac{\partial t}{\partial p} \right)_{e+pv} = -\frac{1}{c_p} \left(v + \theta \frac{\partial s}{\partial p} \right);$$

whereupon elimination of $\partial s / \partial p$ yields a differential equation for θ ,

$$\frac{1}{\theta} \frac{d\theta}{dt} = \frac{1}{v + c_p \psi} \left(\frac{\partial v}{\partial t} \right)_p.$$

Dissipation. The conclusion that every controllable irreversible process follows the path of least resistance, and that the work which it could be compelled to develop is dissipated in producing a heating effect, is formulated by the postulate of the "dissipation law":

When a thermally and dynamically isolated body undergoes a change of state that admits of a reversible path, the change of the entropy of the body is positive.

When an adiabatic process is wholly dissipative it is isodynamic; when it is non-dissipative it is isentropic.

A body supporting the uniform and normally directed pressure p at the temperature θ is in a state of stable equilibrium if all possible sets of variations δV , δS , δE of the volume, entropy, and energy of the body satisfy the criterion of stability,

$$\delta E + p\delta V - \theta\delta S \cong 0,$$

where the quantities p , θ are the *constant* pressure and temperature of the given state. The sign of inequality obtains except when the variation of state occurs in a region whose states are stable under the pressure p at the temperature θ .

An Analogy. Let the *load* S of the car of an elevator be the total weight of the car and its freight, and let the *level* θ be the

height of the car above the height from which its potential energy is reckoned. Then the energy E of the loaded car, at rest, is

$$E = \theta S,$$

the differential of which is

$$dE = Sd\theta + \theta dS.$$

Here the term

$$Sd\theta = DW$$

is the element of the work transferred to the car by the hoisting mechanism, and the term

$$\theta dS = DQ$$

is the potential energy transferred to it with the load-increment dS at the level θ . Neither is an exact differential expression in the variables θ , S . Changes of level are supposed conducted reversibly, to avoid complicating the expression for E by the appearance of a term for the kinetic energy of the car.

In its most general change of state, the car continuously gains or loses load at continuously changing level. If we denote the initial and final pairs of values of the variables θ , S by the symbols 1 and 2, the change of the energy in the process is an integral

$$E_2 - E_1 = \int_1^2 (Sd\theta + \theta dS);$$

the work absorbed is a line integral, taken along the prescribed path,

$$W_{12} = \int_1^2 Sd\theta;$$

the potential energy absorbed is a corresponding line integral,

$$Q_{12} = \int_1^2 \theta dS;$$

and the change of load is an integral

$$S_2 - S_1 = \int_1^2 \frac{DQ}{\theta}.$$

If the car traverses a closed path of change of level and load, we have

$$\int_C \frac{DQ}{\theta} = 0,$$

which means merely that the load has regained its initial value.

The formulation of reversible thermodynamic processes is analogous to the above-described state of affairs. The rôle of the car is played by the body whose thermodynamic state is in question. The absolute temperature is the *thermal level* θ , and the entropy is the *thermal load* S , of the body. The thermal energy

$$\theta dS = DQ$$

absorbed by the body corresponds to the potential energy absorbed by the car, and the differential of the energy of the body is equal to the sum of the work-element and heat-element,

$$dE = DW + \theta dS.$$

A distinction between the two cases appears in the circumstance that here the work-element DW is not equal to $Sd\theta$, and hence that the energy of the body is not given by the function θS .

Just as in the preceding case, however, we have that the change of the energy in a reversible process is an integral

$$E_2 - E_1 = \int_1^2 (DW + \theta dS);$$

that the thermal energy absorbed is a line integral,

$$Q_{12} = \int_1^2 \theta dS;$$

and that the change of the thermal load of the body is an integral,

$$S_2 - S_1 = \int_1^2 \frac{DQ}{\theta}.$$

Here, too, along a closed path we have that

$$\int_C \frac{DQ}{\theta} = 0,$$

which means that the thermal load has regained its initial value.

In view of this analogy, it should be helpful to consider that the entropy of a body absorbing heat is the thermal load, or the "weight," of the heat absorbed. And if the formulation of the reversible operation of an elevator is easily comprehended, it should not be difficult to transfer this comprehension to the case in which thermal energy instead of potential energy is transferred.

INDEX

- Absolute temperature, 55, 70, 72;
definition of, 49
Adiabatic process, 21
Ammonium chloride, formation of, 83
Auxiliary fluid, 52–55, 59
- Bodies, states of, 2–4; compression
and expansion of, 15–16; ther-
mally isolated, 17, 21, 63, 85
Body, definition of, 1; energy of a,
8–14; entropy of a, 59–64
- Car, elevator, 12, 20, 24; level and
load of, 100
Carbon dioxide, 4
Carnot cycles, 20, 24; varieties of,
25; isothermal, 26; a sequence of,
29; efficiency of, 44, 52; a theorem
on, 52
Carnot's theorem, 44
Change of state, definition of, 3;
supplementary, 3; cyclic, 10, 20;
of auxiliary fluid, 52–55, 59; gen-
eral cyclic, 59
Chemical reaction, 82
Compression, 15, 80
Conservation of energy, 13
Continuous one-dimensional set, 30
Conversion table, 9
Criterion of stability, 89–92
Cyclic change of state, 10; Carnot's,
20–27; of auxiliary fluid, 52–55;
general, 59–62
- Diffusion, 82
Dissipation, 75, 85; partial, 85
Dissipation law, 85
- Effect, porous plug, 71; free ex-
pansion, 71
- Efficiency of Carnot cycles, 44, 52
Elevator car, 12, 20, 24; level and
load of, 100
Energy, 8; units of, 8; conservation
of, 13
Energy law, 10–11
Entropy, 59, 61–62, 85
Entropy law, 62
Equalization of temperatures, 2, 77, 89
Equilibrium, thermodynamic, 3
Expansion, 15, 79; work of, 15
- Factors, integrating, 64–67
First law of thermodynamics, 9
Fluid, auxiliary, 52–55, 59
Free expansion effect, 71
Friction, 8, 77
Function $q(t_1, t_2)$, 46–48
Function $W(x, t_1, t_2)$, 41; form in x ,
43; form in t_1, t_2 , 45; form of, 48
Functional equations, 43, 45, 46
- General cyclic change of state, 59;
of an auxiliary fluid, 52, 54
Green's theorem, 54
- Heat, quantity of, 2; units of, 8
Heat-elements, 53–55, 60–64; inte-
grating factors of, 64–67
Hydrogen, 52
Hydrogen thermometer, 1–2, 56, 67, 73
- Impact, 76
Integrals, line, 16, 53–55, 60–64
Integrating factors, 64–67
Irreversible processes, 63, 75–92
Isentropic process, 63
Isodynamic process, 76, 85, 86
Isolation, thermal, 17, 21, 63, 85
Isometric process, 24

104 GENERAL THEORY OF THERMODYNAMICS

- Isothermal cycles, 26, 27, 40-41, 59
Isothermal process, 21
- Law, first, of thermodynamics, 9;
energy, 10; second, of thermodynamics, 32; entropy, 62; dissipation, 85
- Least resistance, 75
- Level, thermal, 21, 102; of an elevator car, 100
- Line integrals, 16, 53-55, 60-64
- Load, thermal, 21, 102; of an elevator car, 100
- One-dimensional set, 30
- Paths, of change of state, 3, 11;
reversible, 16; irreversible, 18-20, 63, 75-92; of least resistance, 75
- Porous plug effect, 71
- Potassium sulphocyanate, 82
- Process, cyclic, 10, 20-27, 52-55, 59-62; reversible, 16; irreversible, 18-20, 63, 75-92; adiabatic, 21; isothermal, 21; isometric, 24; isentropic, 63; isodynamic, 76, 85, 86; uncontrollable, 82
- Quantity of heat, 2
- Reference, state of, 11, 62; temperature of, 49, 70, 73
- Reversibility, 16-19
- Second law of thermodynamics, 32
- Sequence, 15, 27, 29; work absorbed by a, 38; theorem on, 41
- Sequences, theorem on, 34-37
- Set, continuous one-dimensional, 30
- Stability, criterion of, 89-92
- State, thermodynamic, 2; change of, 3; of equilibrium, 3; supplementary changes of, 3; regions of, 4, 53-55, 60-64, 91, 92; cyclic changes of, 10, 20-30, 52, 54, 59; of reference, 11, 62
- Supercooled water, 83
- Supplementary changes of state, 3
- Table, conversion, 9
- Temperature, 1; absolute, 49, 55, 70, 72; of reference, 49, 70, 73
- Temperature equalization, 2, 77, 89
- Thermal isolation, 17, 21, 63, 85
- Thermodynamic equilibrium, 3; regions of states of, 4
- Thermodynamics, first law of, 9; second law of, 32
- Thermometers, 1-2; hydrogen, 56, 67, 73
- Uncontrollable processes, 82
- Units, energy, 8
- Varieties of Carnot cycles, 25
- Water, as a working fluid, 24-25, 26, 27; supercooled, 83
- Work, of compression or expansion, 15; absorbed by a sequence, 38, 41; form in x , 43; form in t_1, t_2 , 45; form of, 48
- Work-elements, 15, 55, 60, 63

