

**TEXT FLY WITHIN
THE BOOK ONLY**

UNIVERSAL
LIBRARY

OU 160882

UNIVERSAL
LIBRARY

OSMANIA UNIVERSITY LIBRARY

Call No.

629.134354
R82 M

Accession No. Gr. 10267

Author

Rosser, J Barkley, and others.

Title

Mathematical Theory of rocket flight

This book should be returned on or before the date last marked below. 196

*MATHEMATICAL THEORY
OF ROCKET FLIGHT*

MATHEMATICAL THEORY OF ROCKET FLIGHT

BY

J. BARKLEY ROSSER, PH.D.

*Professor of Mathematics at Cornell University
Formerly, Chief, Theoretical Ballistics Section
Allegany Ballistics Laboratory*

ROBERT R. NEWTON, PH.D.

*Member of Technical Staff, Bell Telephone
Laboratories, Inc., Murray Hill, N. J.
Formerly, Research Associate
Allegany Ballistics Laboratory*

GEORGE L. GROSS, PH.D.

*Research Engineer in Applied Mathematics, Grumman
Aircraft Engineering Corporation; Bethpage, N. Y.
Formerly, Research Associate
Allegany Ballistics Laboratory*

Office of Scientific Research and Development
National Defense Research Committee

NEW YORK AND LONDON

McGRAW-HILL BOOK COMPANY, INC.

1947

MATHEMATICAL THEORY OF ROCKET FLIGHT

PRINTED IN THE UNITED STATES OF AMERICA

PREFACE

This is the official final report to the Office of Scientific Research and Development concerning the work done on the exterior ballistics of fin-stabilized rocket projectiles under the supervision of Section H of Division 3 of the National Defense Research Committee at the Allegany Ballistics Laboratory during 1944 and 1945, when the laboratory was operated by The George Washington University under contract OEMsr-273 with the Office of Scientific Research and Development. As such, its official title is "Final Report No. B2.2 of the Allegany Ballistics Laboratory, OSRD 5878."

After the removal of secrecy restrictions on this report, a considerable amount of expository material was added. It is our hope that thereby the report has been made readable for anyone interested in the flight of rockets. Two slightly different types of readers are anticipated. One is the trained scientist who has had no previous experience with rockets. The other is the person with little scientific training who is interested in what makes a rocket go. The first type of reader should be able to comprehend the report in its entirety. For the benefit of the second type of reader, who will wish to skip the more mathematical portions, we have attempted to supply simple explanations at the beginnings of most sections telling what is to be accomplished in those sections. It is our hope that a reader can, if so minded, skip most of the mathematics and still be able to form a general idea of rocket flight.

Although this is a report of the work done at Allegany Ballistics Laboratory, it must not be supposed that all the material in the report originated there. We have been most fortunate in receiving the wholehearted cooperation and assistance of scientists in other laboratories. Many of them, notably the English scientists, were well advanced in the theory before we even began. Without the fine start given us by these other workers, this report could certainly not have been written. However, we were fortunate enough to discover two means of avoiding certain difficulties of the theory. The first is that of using some dynamical laws especially suited to rockets in deriving the equations of motion, and the second is that of using some mathematical functions especially suited to rockets in solving the equations of motion. The explanation and illustration of these simplifying devices take up a considerable portion of the report, although for completeness we have included material not involving them.

In attempting to acknowledge the contributions of other workers, we are in a difficult position. Approximately a hundred reports by other workers were useful in one way or another in the preparation of this report. However, most of them are still bound by military secrecy, so that only the few cited in our meager list of bibliographical references can be mentioned here. Many figures are copied from these unmentioned reports. Sizable portions of our report, such as Chap. II and Appendix 1, lean very heavily on certain of these unmentioned reports, but no specific credit is given. We ask the reader to bear in mind that this report, like any comprehensive scientific report, covers the work of many contributors, and, although we are among the contributors, our present role is that of expositors.

Among the many scientists to whom we are indebted, certain ones have been especially helpful, namely, Leon Blitzler, Leverett Davis, F. T. McClure, E. J. McShane, and R. J. Walker. We regret that we cannot be more explicit as to the nature of their contributions, and the contributions of others.

For their work in computing Tables 1 to 4, and for their assistance with computational matters in general, we wish to thank J. A. Brittain and E. M. Cook.

We wish further to express our gratitude for the willing assistance furnished by our associates in the Allegany Ballistics Laboratory and The George Washington University, and for the encouragement that came from officials of the National Defense Research Committee and the Office of Scientific Research and Development.

The publishers have agreed that ten years after the date on which this volume is issued the copyright thereon shall be relinquished, and the work shall become part of the public domain.

J. BARKLEY ROSSER
ROBERT R. NEWTON
GEORGE L. GROSS

ITHACA, N. Y.,
May, 1947.

CONTENTS

PREFACE	v
CHAPTER I	
THE EQUATIONS OF MOTION OF A ROCKET	1
The Jet Forces on a Rocket, 1; The Aerodynamic Forces on a Non-spinning Rocket, 23; Definition of Coordinate Systems, 34; Gravity, 39; The Equations of Motion of a Nonspinning Rocket, 39.	
CHAPTER II	
MOTION AFTER BURNING	49
The Vacuum Trajectory, 53; Definition of Dispersion, 53; Sources of Dispersion, 57; An Expression for the Yaw, 60; Solution for the Dispersion, 67; An Estimate of the Dispersion Due to Yaw Drag, 69; Dispersion Due to Lift, 72; Dispersion Due to the Cross-spin Force, 74; Application to a Different Projectile, 75; Reconsideration of Certain Assumptions, 75; A Numerical Example, 77.	
CHAPTER III	
MOTION DURING BURNING.	78
The Basic Solution, 81; Numerical Examples, 97; The General Solution, 107; Special Solutions for the Velocity, 116; The Basic Solution for Dispersion in Firing from Aircraft, 118; The Basic Solution for Firing in a Vacuum, 123; Useful Mathematical Relations, 125; The Effect of Lift, Cross-spin Force, and Damping Moment, 131; The Effect of Jet Damping, 134; The Effect of Drag and Nonuniform Acceleration Due to the Rocket Thrust, 136; The Effect of a Variable Wave Length of Yaw, 140; The Dispersion of a Rocket with a Constant Angular Acceleration about its Axis of Symmetry, in a Vacuum and in Air, 141; The Dispersion of a Rocket with a Constant Angular Velocity about Its Axis of Symmetry, in a Vacuum and in Air, 153; Motion during Burning of an Unstable Rocket, 162; Motion during Burning with a Large Initial Yaw, 167; Experimental Verification of the Theory. Importance of Various Sources of Dispersion, 173.	
CHAPTER IV	
BOUNDARY CONDITIONS	184
Launcher Velocity, 185; Tipping-off Effects, 187.	
CHAPTER V	
PROPERTIES OF THE ROCKET FUNCTIONS.	196
Notation and Definition of the Functions, 196; Derivatives of the Functions, 198; Integrals That Can Be Verified by Differentiation, 198; Integrals Obtained by Special Methods, 201; Relations with Other Functions, 206; Power Series for the Functions, 208; Asymptotic Expansions for the Functions, 210; Other Means of Computation, 213; Accuracy of Interpolation in Table 1, 215; Table 1. Rocket Functions, 220; Table 2. Values of $E_2(p) = p(1 - p^2)/6$ to 5 Decimal Places, 234.	

APPENDIXES

1. A SIMPLIFIED THEORY OF FLOW THROUGH A NOZZLE	237
2. DERIVATION OF PRINCIPLE V	243
3. MINOR FACTORS AFFECTING THE FLIGHT OF A ROCKET	247
4. FUNCTIONS FOR USE WITH AN UNSTABLE ROCKET	253
Table 3. Functions for Use with an Unstable Rocket, 257.	
5. FUNCTIONS FOR USE WITH JET DAMPING	258
Table 4. Functions for Use with Jet Damping, 262.	
BIBLIOGRAPHY	263
GLOSSARY OF SYMBOLS	265
INDEX.	273

CHAPTER I

THE EQUATIONS OF MOTION OF A ROCKET

It is often stated that the motion of a rocket can be derived from Newton's laws of motion. In the strict sense, to do so would require considering the motions of all the molecules of gas within the rocket blast, as well as the motions of those air molecules with which the rocket comes into contact. This would involve intolerable complexity.

Accordingly, some simplified theory is necessary, both for the gas flow inside the rocket and for the air flow outside the rocket. The simplified theories presented herein have been developed by a combination of theory and experience. We have tried to explain these simplifications fairly fully and have tried to indicate their background and shortcomings as well as explain their usefulness.

1. The Jet Forces on a Rocket

Preliminary Ideas.—In Fig. I.1.1, we picture the essential features of a rocket. The gas generated in the chamber at high pressure expands rapidly and so rushes out of the nozzle at a great velocity, forming the jet. The burning of the rocket propellant fuel continually furnishes more gas to the chamber, maintaining the gas supply and the high chamber pressure.

In small rockets, such as the bazooka rocket, current practice is to use solid fuel. The chamber is filled in advance with solid pieces of powder of composition similar to that used in large guns. When the powder is ignited, it burns rapidly, furnishing a continuous supply of gas at high pressure. A typical chamber pressure P_c might be 2,000 lb/in.² With such a high chamber pressure, the pressure at the exit P_e is fairly high, for instance, 220 lb/in.² A typical value for the velocity at the exit v_e might be 6,200 ft./sec.

In large rockets, it is more common to use liquid fuel. For instance, in the German V-2, which was used against London in the fall of 1944, alcohol and liquid oxygen are continuously pumped into the chamber, where they combine chemically to produce an ample supply of gas at high pressure. A typical chamber pressure for a liquid-fuel rocket might be 300 lb/in.² With this smaller chamber pressure, we have a smaller exit pressure, say perhaps approximately sea-level atmospheric

pressure, or 15 lb/in.² For liquid fuels, a typical value of v_0 might be 6,000 ft/sec.

We shall not be concerned further with the mechanism by which gas is supplied to the chamber at the proper pressure and in the proper amounts. This is part of the "interior ballistics" of rockets. We merely state that rockets are commonly designed so that the chamber pressure is constant. However, this is not always desirable or feasible; instead, some rockets burn progressively, that is, the pressure increases as the rocket burns, while other rockets burn regressively, that is, the pressure decreases. Nevertheless, for a first approximation, it is usual to assume a constant chamber pressure.

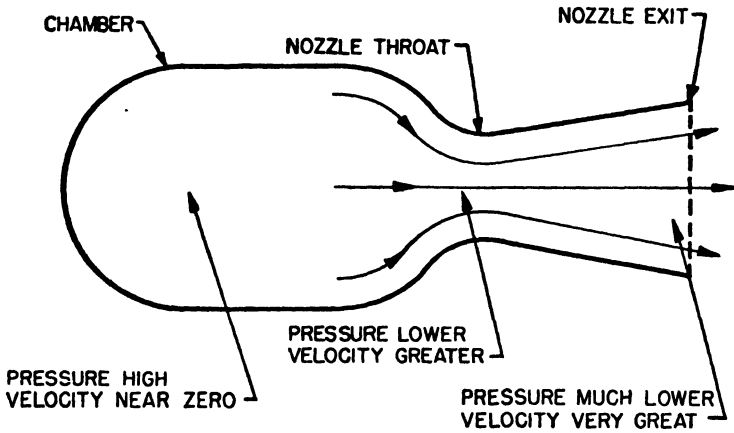

FIG. I.1.1.—The essential features of a rocket.

We shall need certain information about the behavior of the gas in the jet. To supply this information we have given in Appendix 1 a simplified theory of the motion of the gas through the nozzle. We here present a few high points of this theory. At the throat, the velocity of the gas is the so-called "local velocity of sound." This is the velocity with which a normal disturbance in the gas, in particular a sound wave, would be propagated through the gas. The adjective "local" is adjoined because the velocity of sound depends on the condition of the gas (mainly the temperature), and this is changing as we proceed along the nozzle. Incidentally, the condition of the gas at the throat is such that the local velocity of sound there may run as high as two or three times the velocity of sound in normal air (see Appendix 1).

Before the gas gets to the throat, its velocity is below the local velocity of sound; after the gas passes the throat its velocity is above the local velocity of sound. This fact is of the utmost importance,

since, as a result, conditions outside the rocket usually do not affect conditions in the nozzle or interior of the rocket. The explanation is very simple. If a variation of conditions or other disturbance in the gas outside the rocket is to be felt inside the rocket, this disturbance must be propagated through the gas in the nozzle to the gas inside the chamber. That is, the disturbance must move upstream against the blast of the rocket jet. As the jet at the exit of the nozzle has a velocity well above the local velocity of sound, whereas the disturbance is propagated at the local velocity of sound, the disturbance will be swept downstream and so cannot affect conditions inside the nozzle or chamber.

Accordingly, in computing jet forces, we need not consider external circumstances at all.

The above comforting generality, like all generalities, is untrue in extreme cases. If the chamber pressure is less than twice the external pressure or if the exit pressure is less than the external pressure, the flow pattern presented in Appendix 1 breaks down, and then external conditions can affect conditions inside the rocket. This would have an adverse effect upon the behavior of the rocket, so that rocket designers take pains to avoid such extreme conditions. Accordingly, we shall proceed with full confidence that external conditions do not affect the thrust of the jet.

The Classical Treatment.—In the classical derivation of jet forces, the principle of conservation of momentum is used. One assumes that the gas is issuing out the rear of the rocket with a velocity of v_E relative to the rocket. Thus in time dt , a mass dm of fuel is burnt and the gaseous products are hurled out the rear at a relative velocity of v_E . At the beginning of the time dt , our rocket and unburnt fuel have a total momentum of Mv , where v is the velocity of the rocket and M is the mass of the rocket and unburnt fuel. We let m denote the amount of fuel already burnt. At the end of time dt , the momentum of this same system now consists of two parts, the momentum

$$(M - dm)(v + dv)$$

of the rocket and remaining unburnt fuel plus the momentum

$$(v - v_E) dm$$

of the mass of fuel that was burnt in time dt and hurled out the rear. Equating total momenta before and after burning gives

$$Mv = (M - dm)(v + dv) + (v - v_E) dm$$

This reduces to

$$v_E dm = M dv - dm dv$$

Dividing by dt and taking limits, we get

$$M\dot{v} = \dot{m}v_E, \quad (\text{I.1.1})$$

where a dot represents a derivative with respect to time. This is the classic equation for the acceleration of a rocket.

Other Considerations.—This formula is qualitatively right and can be used for rough predictions as to the behavior of rockets in general. However, many refinements are necessary before one has a complete picture of the jet forces acting on a rocket.

We have spoken of v_E as the velocity of the gas in the jet relative to the nozzle, which would make v_E the same as v_c . However, if (I.1.1) is to be correct, v_E cannot be the same as v_c , as we shall see in detail below. Nevertheless, if we define v_E as the velocity that makes (I.1.1) a true equation, then v_E becomes a very useful concept in rocket theory. In the usual terminology, v_c is called the “exit velocity,” whereas v_E is called the “effective gas velocity.” Typical values for a rocket might be

$$\begin{aligned} v_c &= 6,200 \text{ ft/sec} \\ v_E &= 7,300 \text{ ft/sec} \end{aligned}$$

(see Appendix 1).

The physical reason for the discrepancy between v_c and v_E is that, at the exit of the nozzle, the gas is still under considerable pressure. This pressure is responsible for an appreciable amount of the thrust on a rocket, which is why one cannot take v_E equal to v_c in (I.1.1). Because of this pressure at the exit of the nozzle, the gas will continue to expand and accelerate (relative to the rocket) after it leaves the exit. Thus, in a vacuum the gas will finally attain the velocity v_E , but in the atmosphere it cannot attain the velocity v_E because of collision with stationary air molecules.

One can compute the ultimate velocity that the gas could attain upon complete expansion in a vacuum (see Appendix 1). One must not suppose that this ultimate velocity can be used as a value for v_E even in a vacuum. When the gas is freed of the restraint of the nozzle, it will expand sidewise as well as to the rear, so that when it has expanded completely and accelerated to its ultimate velocity, much of the gas will be moving at a considerable angle to the axis of the rocket rather than straight to the rear. Thus v_E is probably the average rearward component of the ultimate velocity of the various particles of gas. However, to find v_E by solving the gas-flow equations of the expanding gas and then averaging the rearward components of the ultimate velocity will involve great complication, so much so that it appears that we shall have to abandon the simple momentum

argument used in the classical derivation of jet forces. However, before we do so, it will be instructive to obtain certain further qualitative information.

We saw above that v_E falls short of the ultimate gas velocity because after the gas leaves the nozzle it can expand sidewise as well as straight back. If the nozzle were not cut off but were extended on back indefinitely, the sidewise expansion would be restrained (except for a small amount permitted by the divergence of the nozzle). Thus a larger value of v_E would result. However, with an actual metal nozzle, one cannot extend the nozzle indefinitely. In fact, considerations of weight of nozzle and the like will compel one to use a much shorter nozzle than would otherwise be desirable.

The ratio of the cross-section area at the exit to that at the throat is called the "expansion ratio." Current expansion ratios do not run much over 4 and are sometimes as small as 2. Let us go back to the question of how long a nozzle should be. We recall that a basic desideratum is to curtail sidewise expansion of the gas in the jet. For a nozzle that diverges slowly, this can be done by lengthening the nozzle, which results in an increase of the expansion ratio. Therefore, it has become customary to say that increasing its expansion ratio will make a nozzle more efficient. In the sense just explained, this is true. Unfortunately it has become a pat saying, and one hears it stated uncategorically that a large expansion ratio will automatically give an efficient nozzle. Certain unthinking designers, accepting this as gospel, have proposed making extremely divergent nozzles, so as to get a large expansion ratio. However, a very divergent nozzle will permit much sidewise expansion of the gas, and, as we saw above, this is not desirable. It may be true that in some cases a widely divergent nozzle is a useful compromise among the various desiderata of light metal parts, large value of v_E , etc. Nevertheless, the proper choice of nozzle shapes is difficult and cannot be solved merely by the unthinking application of rules of thumb in situations where they do not apply.

Such considerations as the above illustrate the value of the type of reasoning used in the derivation of (I.1.1), while at the same time they point out the difficulties of trying to estimate v_E from simple gas-flow considerations. We might note further difficulties that arise when the rocket is fired in air, namely, that the blast from the jet will entrain a considerable amount of the surrounding air and also will pass through a very complex set of shock waves. These effects further complicate any attempt to make a simple momentum argument more exact.

A General Principle of Mechanics.—When one abandons the simple momentum argument, it seems that one can proceed most expeditiously by first deriving a special principle of mechanics particularly suitable for use with rockets. We have not been able to find this principle stated elsewhere, but we hesitate to call it new because no great originality was involved in its discovery. In fact, it is very closely related to the momentum theorem of hydrodynamics (see Reference 11, Chap. XIV). This special principle is a generalization of the following well-known principle, which we quote from Reference 9, page 58:

PRINCIPLE I. The time rate of change of the total momentum of the system is equal to the vector sum of all the exterior forces that are acting on the system.

If one checks through the proof of this principle, one finds that it refers only to a system that always consists of the same set of particles. However, a burning rocket is not such a system, since it achieves its propulsion by throwing particles out the rear.

We enunciate our special principle in the following form:

PRINCIPLE II. If one has a system S of particles, then the vector sum of all the exterior forces acting on S is equal to the time rate of change of the total momentum of S plus the rate at which momentum is being transferred out of S by the particles that are leaving S .

This follows rather easily from Principle I. Consider a particular time τ at which we wish to establish the principle. Define an auxiliary system S^* as always consisting of exactly those particles which are in S at time τ . For the remainder of this proof, it will be convenient to denote the vector sum of the exterior forces acting on S at time t by $\Sigma F^e(t)$, the total momentum of S at time t by $M(t)$, and the total momentum of S^* at time t by $M^*(t)$. Now since S^* always consists of the same set of particles, we can apply Principle I to it, and we choose to do so at time τ . At this time, S and S^* coincide and so are acted on by the same set of exterior forces, namely, $\Sigma F^e(\tau)$. So, by Principle I,

$$\Sigma F^e(\tau) = \left. \frac{d}{dt} M^*(t) \right]_{t=\tau}$$

Using differentials, we write this in the form

$$\Sigma F^e(\tau) dt = M^*(\tau + dt) - M^*(\tau)$$

Since S and S^* coincide at time τ ,

$$M^*(\tau) = M(\tau)$$

Now let us consider $M^*(\tau + dt)$. At time $\tau + dt$, S^* consists of those particles which are in S and in addition those particles which have left S in the interval from τ to $\tau + dt$. Therefore, the momentum of S^* , $M^*(\tau + dt)$, consists of the momentum of S , $M(\tau + dt)$, plus the momentum ΔM removed from S by those particles which left S in the interval from τ to $\tau + dt$. Thus we have

$$\Sigma F^e(\tau) dt = M(\tau + dt) + \Delta M - M(\tau)$$

and

$$\Sigma F^e(\tau) = \frac{M(\tau + dt) - M(\tau)}{dt} + \frac{\Delta M}{dt}$$

If now we let $dt \rightarrow 0$, we shall have established Principle II as holding at time τ . However, we have not introduced any restrictions on the time τ , and so Principle II holds in general.

Principle II holds for systems that gain particles as well as systems that lose particles, provided we affect the momentum of the incoming particles with a minus sign.

Another Equation for the Acceleration of a Rocket.—We now use Principle II to derive an equation for the acceleration of a rocket. Let us consider a rocket motor such as that illustrated schematically in Fig. I.1.1. The dotted line across the exit of the nozzle in Fig. I.1.1 represents a geometric surface fixed relative to the metal parts. For the application of Principle II, we define our system to consist of the metal parts of the rocket, the unburnt fuel of the rocket, and the gas inside our geometric surface. The momentum of the system is equal to the mass of the system times its velocity, that is, Mv . The rate at which the departing particles remove momentum from the system is just the rate at which momentum crosses the exit surface. If the velocity of the gas relative to the rocket at the exit of the nozzle is v_e , then the gas crossing the exit surface has a velocity of $v - v_e$. So if \dot{m} is the rate at which gas is streaming through the exit surface, then the jet is taking momentum from our system at the rate of $\dot{m}(v - v_e)$, and, by Principle II,

$$\Sigma F^e(t) = \frac{d}{dt} (Mv) + \dot{m}(v - v_e)$$

Now since \dot{m} is the rate at which fuel is being burnt, we have

$$\frac{d}{dt} M = -\dot{m}.$$

Therefore

$$\frac{d}{dt}(Mv) + \dot{m}(v - v_e) = M\dot{v} - \dot{m}v + \dot{m}(v - v_e) = M\dot{v} - \dot{m}v_e$$

and

$$M\dot{v} = \dot{m}v_e + \Sigma F^c(t)$$

It remains to analyze $\Sigma F^c(t)$. Among the exterior forces acting on our system are the gas pressures over the surface of the system and gravity acting through the center of gravity. The gas pressures consist of atmospheric pressure over the outside of the rocket and the jet pressure over the exit surface. If A_e is the area of the exit plane and P_e is the jet pressure at the exit surface, then the force due to jet pressure is $P_e A_e$.

The atmospheric pressure is composed of the static atmospheric pressure plus the aerodynamic forces due to motion through the air. The static atmospheric pressure is not considered as part of the aerodynamic forces. For rockets this creates rather an anomalous situation, so that it is worth while to explain why this is done. For shells and airplanes and such nonrockets, the net force due to the air is zero when there is no relative air motion. Only in cases of relative motion do the aerodynamic forces need to be considered. So, as a matter of historical precedent, it came to be considered that aerodynamic forces are zero on a body at rest. However, for a rocket at rest the force due to the static atmospheric pressure is *not* zero. Therefore, to preserve the fiction that at rest the aerodynamic forces are zero, the force due to the static atmospheric pressure must be segregated from the aerodynamic forces. Strangely enough, it is counted as part of the jet forces.

The argument given to justify this runs so: Let us put a rocket in a test stand, lying horizontal on rollers that counteract the gravitational forces, with the nose against a thrust gauge, and fire the rocket. Since the rocket is held stationary, the thrust registered by the thrust gauge must be due to jet forces alone. The reader will observe how this argument appeals to the notion that aerodynamic forces must be zero on any stationary body and so forces us to include static atmospheric pressure in the jet forces. It is hardly good logic, but it is tradition. We abide by it and proceed with the derivation.

If static atmospheric pressure should act on the entire surface of a body, there is clearly no net force. Hence the force due to static atmospheric pressure over part of the surface is just the negative of the force that would be produced by static atmospheric pressure over the rest of the surface. Applying this result to our rocket, we see

that the force due to static atmospheric pressure over the outside of the rocket is just the negative of the force that would be produced by static atmospheric pressure over the exit surface, that is, $-P_a A_e$, where P_a is the static atmospheric pressure.

The remaining forces due to atmospheric pressure are due to motion through the air and so are considered as aerodynamic forces. We denote them by F_a and consider them in detail in Sec. 2.

We now collect together the above and other forces and write

$$\Sigma F^e(t) = P_c A_c - P_a A_e - F_a - M g_x - F$$

The terms appearing in this equation are appropriate components of the forces. We have attached a minus sign to F_a to accord with the usual conventions as to the direction of application of the aerodynamic forces. By g_x we understand the component of gravity in the appropriate direction. The term F includes all other exterior forces, for instance, if our rocket is towing out a line, or the like. Rather commonly F will be zero. So we have finally

$$M \dot{v} = \dot{m} v_c + (P_c - P_a) A_e - F_a - M g_x - F \quad (\text{I.1.2})$$

We proceed to make a useful deduction from (I.1.2). Let us consider a rocket fastened in a test stand. Since the rocket is held motionless by the test stand, $\dot{v} = 0$. Also, there are no aerodynamic forces on a stationary rocket, so that $F_a = 0$. We further assume that the rocket is held in a horizontal position, so that $g_x = 0$. Naturally, F is just the thrust T of the rocket, as measured by the thrust gauge. So (I.1.2) reduces to

$$T = \dot{m} v_c + (P_c - P_a) A_e \quad (\text{I.1.3})$$

This tells us that $\dot{m} v_c + (P_c - P_a) A_e$ is the thrust due to the rocket jet. So by means of the theory of Appendix 1, one can compute the jet thrust from theoretical considerations alone. The computed value agrees reasonably well with the experimental value as determined on a test stand, thus validating the theory of Appendix 1. (I.1.3) also refutes the opinion, which is common among the uninformed, that a rocket operates by "pushing on the air." More than that, it shows that atmospheric pressure decreases the thrust of a rocket, giving the lie to our earlier dictum that the jet forces are independent of conditions external to the rocket. We purposely left this dictum incorrectly stated at the time in accordance with the principle of not bringing in too many new ideas at once. At that point in the discussion, we and the reader were assuming as jet forces only those forces really due to the jet, and in that sense the statement was genuinely true because it is certainly the case that flow in the nozzle is

independent of exterior conditions. Since then we have asked the reader to modify his notion of jet forces to include explicitly the static atmospheric pressure, thus replacing our earlier statement by (I.1.3).

Combining (I.1.2) and (I.1.3), we get

$$M\dot{v} = T - F_a - Mg_x - F$$

We express this important conclusion in words:

PRINCIPLE III. The total of exterior and jet forces acting on a rocket is equal to the mass of the rocket times the acceleration of the rocket.

This sounds suspiciously like Newton's law that force equals mass times acceleration. For this reason, Principle III was at one time a source of considerable misunderstanding, since a number of investigators, having Principle I in mind, wished to state Principle III in the incorrect form that the total force acting on a rocket is equal to the time rate of change of momentum of the rocket.

If we ignore F_a , Mg_x , and F in (I.1.2) we obtain the analogue of (I.1.1), since in deriving (I.1.1) only jet effects were considered. Thus we are enabled to write

$$\dot{m}v_E = M\dot{v} = \dot{m}v_e + (P_e - P_a)A_e = T \quad (\text{I.1.4})$$

This gives a means of determining v_E experimentally or computing it theoretically. One should note that v_E depends on the atmospheric pressure, so that in stating a value of v_E one should state the relevant air pressure. Thus one may speak of the value of v_E at sea level, at an altitude of 5 miles, etc.

Another way of determining v_E experimentally is in common use in those cases where v_E is essentially constant throughout the burning of a rocket. Multiplying (I.1.1) by dt and recalling that

$$\dot{m} = -\frac{dM}{dt}$$

we get

$$M dv = -v_E dM$$

So

$$dv = -v_E \frac{dM}{M}$$

Assuming that the rocket starts from rest, and integrating both sides over the period of burning of the rocket, we get

$$v_b = v_E \ln \frac{M_a}{M_b}$$

where v_b is the velocity at the end of burning, and M_o and M_b are the masses of the rocket (plus unburnt fuel) at the beginning and end of burning. By measuring v_b , M_o , and M_b , one can determine v_E .

Besides assuming a constant value of v_E , the above equation neglects air drag and gravity. Nevertheless, there were many artillery rockets for which the accuracy of the equation was as great as the accuracy with which v_b could be measured. Should more accurate measurements of v_b become available, one would perhaps wish to integrate (I.1.2) instead of (I.1.1).

There are circumstances in which one may expect a reasonably constant value of v_E . Suppose we have a fixed design of nozzle. Then A_c and v_c are fixed, whereas \dot{m} and P_c are both proportional to the chamber pressure (see Appendix 1). Thus $P_c A_c$ and $\dot{m} v_c$ are both proportional to \dot{m} . Hence $\dot{m} v_c + (P_c - P_a) A_c$ is proportional to \dot{m} except for the term $-P_a A_c$. In case this is relatively small, which is usual, we see by (I.1.4) that v_E will be nearly constant.

On the other hand, if one allows the expansion ratio to vary, $P_c A_c$ will not remain proportional to \dot{m} , and v_c will vary, so that (I.1.4) gives quantitative expression to the fact noted earlier that v_E varies if the expansion ratio varies.

Equations Governing Rotation.—Here one can make a simple argument based on the conservation of angular momentum. However, it is not so successful as the corresponding argument based on conservation of momentum was for translatory motion. We shall discuss this point in some detail later. Here we proceed to give the more valid treatment. As in the case of translatory motion, it is most expeditious to proceed by deriving a special principle of mechanics. This principle is a generalization of the following important principle, which we quote from Reference 9, page 64:

PRINCIPLE IV. The time rate of change of the moment of momentum of the system with respect to any axis which passes through the center of gravity (and therefore moves with the system) and is fixed in direction is equal to the moment of the exterior forces with respect to that axis.

For the benefit of the reader who is unfamiliar with these terms and who does not wish to look them up in Reference 9, we shall give an explanation later on when we apply Principle V.

As with Principle I, Principle IV is valid only for a system that always consists of the same set of particles.

We enunciate our special principle in the following form:

PRINCIPLE V. If one has a system S of particles, then the moment of the exterior forces acting on S , taken with respect to any axis which

passes through the center of gravity of S and is fixed in direction, is equal to the time rate of change of the moment of momentum of S , taken with respect to that axis, plus the rate at which the particles that are leaving S are transferring moment of momentum, taken with respect to that axis, out of S .

The proof of Principle V involves considerable difficulty because of the fact that the axis is allowed to move with the center of gravity of S . Because of this difficulty, we have removed the proof of Principle V to Appendix 2. We proceed now with the applications of Principle V.

Our first application will be to the spinner rocket. In a spinner rocket, the stability necessary to keep the rocket pointing head-on during flight is achieved by spinning the rocket rapidly about a longitudinal axis, in precisely the same way that an artillery shell is kept stable by fast rotation. In the case of the shell, the rotation is imparted to the shell by the spiral rifling of the gun bore. In the case of the rocket, at least two different methods of producing the desired spin have been used. An early American rocket designer, William Hale, used slanting vanes in the nozzle to produce rotation. A 16-lb spinner rocket designed by Hale is described in the U.S. Ordnance Manual for 1862. None of the Hale-type spinners is currently in use.

The modern type of spinner apparently originated with the Germans in the past war. In this spinner, the customary single nozzle at the rear of a rocket is replaced by a ring of small nozzles. If all the nozzles of the ring are given a sidewise cant, they will tend to rotate the rocket at the same time that they thrust it forward.

Two distinct types of construction are used. In the first, one starts with a flat plate, drills a small hole through on a slant, and widens out each end of the hole with a conical reamer (see Fig. I.1.2 on page 14). In the second, one drills a large hole through on a slant and then drive-fits a small nozzle into the hole (see Fig. I.1.3 on page 14). The two types of nozzles are referred to as "drilled nozzles" and "insert nozzles," respectively. We shall see that the two types of nozzles should be expected to give slightly different rotation characteristics. It has been verified experimentally that in fact they do.

In applying Principle V, we proceed as we did in applying Principle II. We imagine geometric planes across the exits of the various nozzles. Then we take our system S to consist of the metal parts of the rocket, the unburnt fuel of the rocket, and the gas inside the various geometric surfaces. This system is essentially all rotating

at the same rate of rotation ω as the metal parts. There may be some variation from this due to the flow of gas inside the rocket motor. However, one cannot take account of this without a knowledge of the flow conditions inside the motor, which are likely to be very complicated. In any case, it is doubtful if such internal flow contributes more than a very minor variation of the simple picture. So we picture our rocket as all rotating at the same rate ω . Also, we assume that this rotation is about a central longitudinal axis of the rocket that preserves its direction in space and passes through the center of gravity of the rocket. This axis we use for the axis about which we are taking moments in applying Principle V.

We now have to compute the moment of momentum about this axis. By definition, the moment of momentum of a particle about an axis is the product of three factors, namely, the mass of the particle, the distance of the particle from the axis, and the sidewise component of velocity of the particle relative to the axis. In our rocket, rotating at a rate ω , the sidewise component of velocity is $r\omega$ for a particle at distance r from the axis. So the moment of momentum of such a particle is $r^2\omega dM$. Summing this over all particles of the rocket, we get $Mk^2\omega$ as the moment of momentum, where k^2 is the average value of r^2 , averaged over all particles of the rocket. By definition, k is just the radius of gyration about the longitudinal axis.

A simple way of looking at this is to recall that Mk^2 is the moment of inertia I , so that the moment of momentum is just $I\omega$. In this form, we draw an analogy with the linear momentum Mv , taking the moment of inertia I as analogous to the mass M , and the angular velocity ω as analogous to the linear velocity v . For this reason, the moment of momentum is often called the "angular momentum." To complete the analogy, we note that $I\omega$ plays the same role in Principle V that Mv plays in Principle II.

When we come to compute the moment of momentum that the jet is carrying out with it, we again face the problem of averaging over various values of r , this time for the jet. With sufficient accuracy for the present discussion, we can take the average value of r to be the distance from the axis to the center of the exit, and this we denote simply by r .

Let τ be the angle between the axis of the rocket and the axis of the nozzle. Moreover, let \dot{m}_n be the mass rate at which gas is flowing through that particular nozzle. The sidewise component of velocity of the gas is $\omega r - v_n \sin \tau$, so that the rate at which the nozzle is removing moment of momentum from the system is $\dot{m}_n r (\omega r - v_n \sin \tau)$. One now sums this over all the nozzles. If, as is usual, all nozzles

have the same τ , the same v_e , and the same r , the total rate at which moment of momentum is being lost through the nozzles is

$$\dot{m}r(\omega r - v_e \sin \tau)$$

The moment of a force about an axis is just the sidewise component of the force times the distance from the axis; in other words, the twisting torque due to the force. So if $F_j^{(e)}$ are the sidewise components of the various exterior forces and r_j are their distances from the axis, then $\Sigma(r_j \times F_j^{(e)})$ is the moment of the exterior forces.

Combining the above results, we have, by Principle V,

$$\Sigma(r_j \times F_j^{(e)}) = \frac{d}{dt} (Mk^2\omega) + \dot{m}r(\omega r - v_e \sin \tau)$$

We still need to analyze $\Sigma(r_j \times F_j^{(e)})$. Gravity does not contribute anything to the moment of the exterior forces, since our axis runs

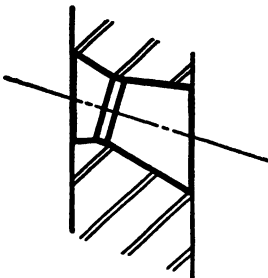

FIG. I.1.2.—Drilled nozzle.

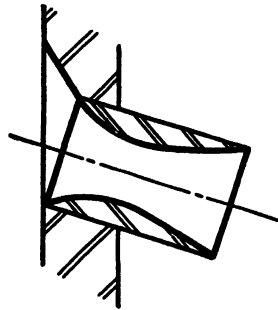

FIG. I.1.3.—Insert nozzle.

through the center of gravity. The various aerodynamic torques we shall denote by J_a . Any other torques will be denoted by J . Rather commonly, J will be zero, but drag on a launcher and such items would come into J .

So far, we have disclosed no difference between drilled nozzles and insert nozzles. It is when we come to the jet pressure over the various exit surfaces and the static atmospheric pressure that we find the difference between the drilled nozzles and the insert nozzles. By the same arguments that were used in deriving (I.1.2), the net force on each exit surface due to jet pressure and static atmospheric pressure is $A_{en}(P_e - P_a)$, where A_{en} is the exit area of the particular nozzle. Note that this force is directed perpendicular to the exit surface. For the drilled nozzles, the exit surface is perpendicular to the axis of the rocket (see Fig. I.1.2), so that the jet pressure and static atmospheric pressure on a drilled nozzle act directly forward and give a zero component of torque for turning the rocket. On the

other hand, the exit surface of the insert nozzle is canted just as much as the nozzle (see Fig. I.1.3), and so it does have a component tending to produce rotation. Summing the contributions of all the nozzles in the case of the insert nozzles, we get a torque of $A_e(P_e - P_a)r \sin \tau$, where A_e is the combined exit area of all the nozzles.

Combining the above, we get two alternative equations:

$$\frac{d}{dt}(Mk^2\omega) + \dot{m}r(\omega r - v_e \sin \tau) = -J_a - J \quad (\text{I.1.5})$$

for drilled nozzles, and

$$\begin{aligned} \frac{d}{dt}(Mk^2\omega) + \dot{m}r(\omega r - v_e \sin \tau) \\ = A_e(P_e - P_a)r \sin \tau - J_a - J \end{aligned} \quad (\text{I.1.6})$$

for insert nozzles.

One might ask if there is an analogue to Principle III. As a general thing, the answer is No. However, for many existing rockets, one is able to make certain simplifying assumptions that permit one to state an analogue of Principle III for these special rockets. We remember that

$$\frac{d}{dt}M = -\dot{m}$$

So

$$\frac{d}{dt}(Mk^2\omega) = -\dot{m}k^2\omega + M\omega \frac{d}{dt}k^2 + Mk^2\dot{\omega}$$

Usually the burning of the fuel makes little difference in k^2 , so that it is often permissible to neglect the term $M\omega(d/dt)k^2$. When the term $-\dot{m}k^2\omega$ is combined with the term $\dot{m}r(\omega r - v_e \sin \tau)$, it can be written in the form $\dot{m}\omega(r^2 - k^2) - \dot{m}rv_e \sin \tau$. For a typical spinner,

$$\begin{aligned} r &= 1.45 \text{ in.} \\ k &= 1.59 \text{ in.} \\ v_e &= 6,000 \text{ ft/sec} \\ \tau &= 17^\circ \end{aligned}$$

and ω is at most 360π rad/sec. We see that $\omega(r^2 - k^2)$ will not run much over 1 per cent of $rv_e \sin \tau$. So we neglect $\dot{m}\omega(r^2 - k^2)$ in comparison with $\dot{m}rv_e \sin \tau$. Thus for certain rockets we can replace (I.1.5) and (I.1.6) by the approximate equations

$$Mk^2\dot{\omega} = \dot{m}v_e r \sin \tau - J_a - J \quad (\text{I.1.7})$$

for drilled nozzles, and

$$Mk^2\dot{\omega} = \dot{m}v_e r \sin \tau + A_e(P_e - P_a)r \sin \tau - J_a - J \quad (\text{I.1.8})$$

for insert nozzles.

One can treat these equations as we treated (I.1.2). Suppose we fasten our rocket in a test stand and measure its thrust and torque with thrust and torque gauges. Then $\dot{\omega}$ would be zero since the rocket is held motionless. For the same reason J_a would be zero. J would be exactly the torque T_J registered by the torque gauges. So we should get

$$T_J = \dot{m}v_e r \sin \tau \quad (\text{I.1.9})$$

for drilled nozzles, and

$$T_J = [\dot{m}v_e + (P_e - P_a)A_e]r \sin \tau \quad (\text{I.1.10})$$

for insert nozzles.

These give a determination of the torque due to the canted nozzles of a spinner rocket. By comparing these with (I.1.7) and (I.1.8), we can conclude:

The total of exterior and jet torques acting on a spinner rocket is equal to the moment of inertia of the rocket times the angular acceleration of the rocket.

This is the strict analogue of Principle III. However, it is not strictly true, although it is approximately true for many types of rockets, and so we do not dignify it by calling it "Principle VI." However, because it is a handy principle, to which we shall wish to refer from time to time, we shall call it the "analogue of Principle III."

A Simple Physical Picture.—It might be well to pause and collect our ideas. From the various equations that have been derived so far, one is entitled to set up a very simple physical picture of the jet forces of a rocket. One must distinguish two kinds of forces, which we shall designate as "momentum forces" and "pressure forces." The momentum forces are equal in value to $\dot{m}v_e$ and are applied in the direction just opposite to the direction of the gas flow. The pressure forces are equal in value to $(P_e - P_a)A_e$ and are applied in the direction perpendicular to the nozzle exit, pointing inward.

The momentum forces arise from the transfer of momentum due to the flow of gas out the exit of the nozzle. The pressure forces arise from the fact that, because of jet action, the pressure across the exit area A_e is $P_e - P_a$ greater than it would be if the jet were not acting.

For determining the effect produced by these forces, we have Principle III and its analogue.

This picture is so simple that one has the feeling that it could not fail to be obvious to anyone considering the problem of rocket motion. Nevertheless, historically such was not the case. In the classic approach only one jet force was considered, namely, a momentum force $\dot{m}v_e$. In (I.1.4) we showed how to define v_B so that in certain

cases it would be correct to replace the two kinds of jet forces by the single force $\dot{m}v_x$. Nevertheless, there are cases where one cannot combine the two kinds of jet force into the single force $\dot{m}v_x$. We prepare to consider such a case in some detail.

Neglecting all but jet forces, we see from (I.1.7) and (I.1.8) that the angular acceleration of a spinner would be given by

$$Mk^2\dot{\omega} = \dot{m}v_e r \sin \tau \quad (\text{I.1.11})$$

for drilled nozzles, and

$$Mk^2\dot{\omega} = [\dot{m}v_e + (P_e - P_a)A_e]r \sin \tau \quad (\text{I.1.12})$$

for insert nozzles.

Take the forward components of the jet forces in the case of a spinner. Since the nozzles are canted, the momentum forces are likewise canted, so that the forward component of the momentum forces is $\dot{m}v_e \cos \tau$. For drilled nozzles, the pressure forces are directed straight forward (see Fig. I.1.2 on page 14) and so the forward component is $(P_e - P_a)A_e$. For the insert nozzles, the pressure forces are canted (see Fig. I.1.3 on page 14), so that the forward component is $(P_e - P_a)A_e \cos \tau$. So if we neglect all but jet forces, we see by Principle III that the forward acceleration of a spinner would be given by

$$M\dot{v} = \dot{m}v_e \cos \tau + (P_e - P_a)A_e \quad (\text{I.1.13})$$

for drilled nozzles, and

$$M\dot{v} = [\dot{m}v_e + (P_e - P_a)A_e] \cos \tau \quad (\text{I.1.14})$$

for insert nozzles.

By (I.1.11) and (I.1.13) or (I.1.12) and (I.1.14), we see that throughout the burning period ω/v will be constant for a rocket starting from rest and will be given by

$$\frac{\omega}{v} = \frac{\dot{m}v_e r \sin \tau}{[\dot{m}v_e \cos \tau + (P_e - P_a)A_e]k^2} \quad (\text{I.1.15})$$

for drilled nozzles, and

$$\frac{\omega}{v} = \frac{r \tan \tau}{k^2} \quad (\text{I.1.16})$$

for insert nozzles.

It is easily seen that ω/v will be smaller for the drilled nozzles than for a set of insert nozzles with the same values of r , τ , and k^2 .

The constant quantity ω/v has a simple physical significance. The fact that ω/v is constant means that, despite the varying speeds and rates of rotation during burning, the rocket will always turn

through an angle proportional to the distance traveled, the factor of proportionality being ω/v . It is fairly easy to verify this fact experimentally. One paints one side of a spinner white and the other side black and photographs the rocket in flight with a high-speed motion camera. Then by measuring the distances traveled between successive apparitions of the white side of the rocket, one can measure ω/v . It is found that ω/v is constant. It is further found that ω/v is smaller for drilled nozzles than for insert nozzles, and within the accuracy of the experiment the respective values of ω/v are given by (I.1.15) and (I.1.16).

There is a bit of history in connection with these experiments. At the time they were performed, it had not become widely known that jet forces had to be separated into momentum forces and pressure forces. It was still common practice to lump all jet forces into a single term $\dot{m}v_E$. The value of v_E had been determined experimentally by measurements on a nonspinning rocket. As a result [see (I.1.4)], the experimenters were using a value of $\dot{m}v_E$ such that

$$\dot{m}v_E = \dot{m}v_e + (P_e - P_a)A_e \quad (\text{I.1.17})$$

As they were considering only one jet force, $\dot{m}v_E$, which they considered as being due to momentum effects, they did not distinguish between drilled and insert nozzles. For both, they put

$$M\dot{v} = \dot{m}v_E \cos \tau \quad (\text{I.1.18})$$

$$Mk^2\dot{\omega} = \dot{m}v_E r \sin \tau \quad (\text{I.1.19})$$

The reader will note that they were using Principle III and its analogue. For their rockets, this was sufficiently accurate.

By (I.1.17), we see that (I.1.18) and (I.1.19) are the same as (I.1.12) and (I.1.14). Thus (I.1.18) and (I.1.19) are correct for insert nozzles but not for drilled nozzles. From (I.1.18) and (I.1.19), the experimenters deduced

$$\frac{\omega}{v} = \frac{r \tan \tau}{k^2} \quad (\text{I.1.20})$$

the same as (I.1.16). For insert nozzles, they verified (I.1.20), but for drilled nozzles they got a smaller experimental value of ω/v than that predicted from (I.1.20). To explain this, they conjectured that because of the sharp edges and lopsided shape of the drilled nozzles, the gas did not actually go through at the angle τ but at some smaller angle τ_e , which they called the "effective cant" as distinguished from the true cant τ . The effective cant was to be determined experimentally so as to make

$$\frac{\omega}{v} = \frac{r \tan \tau_e}{k^2} \quad (\text{I.1.21})$$

There is one interesting aftermath of this bit of history. Though we now explain the deviation from (I.1.20) very easily by using (I.1.15) rather than by assuming any difference between effective cant and true cant, nevertheless it may be asked why there should not be a difference between effective cant and true cant, in view of the lopsidedness of the nozzle. There is the further question as to whether the angular rotation and acceleration of the rocket might not throw the gas flow out of line in some way or other. These are hard questions to answer. If one computes a theoretical value of the effective cant by combining (I.1.21) with (I.1.15), the theoretical value agrees with the experimental value within the accuracy of the experiment. This indicates that the gas does actually go through at the angle τ , despite the rotation of the rocket and the lopsidedness of the nozzles. However, the experimental determination of the effective cant is not highly accurate, so that the evidence is not conclusive.

One can make a rough argument as to the effect of the lopsidedness of the nozzle, as follows: When the gas reaches the exit of the nozzle, the gas at the outside of the jet can begin to expand very rapidly sidewise. Thus an expansion wave begins at the edge of the nozzle exit and is propagated into the jet stream with the speed of sound. However, the jet is moving at perhaps twice the speed of sound, so that the expansion wave gets swept downstream faster than it can proceed across stream. Even with a very canted nozzle, the expansion wave does not go across the jet fast enough to get actually inside the nozzle, so that the flow down the long side of the nozzle will be the same as if the other side had not been cut off short.

Now, of course, we can no longer divert the reader's attention from the fact that, with a drilled nozzle, different parts of the exit surface are not all at the same distance from the throat, and so do not all have the same value of v_e and P_e . Thus the simple products $m v_e$ and $P_e A_e$ have to be replaced by complex integrations. Not that this fact alters the basic picture; it just makes the formulas more elaborate. The bright side to the picture is that it seems easier to manufacture the insert nozzle than the drilled nozzle, so that perhaps we can soon forget the drilled nozzle and confine our attention to the insert nozzles, for which these complications do not arise.

Jet Damping.—We have been discussing spinners, which rotate about a longitudinal axis. However, a rocket can rotate about some other axis instead. Let us consider such a rotation. To be specific, suppose that the rocket is rotating about an axis perpendicular to its

longitudinal axis. That is to say, it is turning end over end, but very slowly. In ballistic parlance, this type of rotation is called a "yawing" motion, whereas rotation about a longitudinal axis is called a "spinning" motion.

The ballistic effects of yawing and spinning motions are quite different. When a rocket yaws, the result is to turn it more or less crosswise in flight, instead of head-on. This causes an increased air resistance, with resultant disturbance of the flight. By and large, yawing motion is to be avoided as far as possible. On the other hand, a fast spin has practically no deleterious effect on the flight and, because of gyroscopic action, tends to prevent yawing motion. Thus a fast spin is frequently desirable. This is precisely analogous to the situation with regard to spinning shells. As it happens, even a spin too slow for gyroscopic effects can also be quite helpful for rockets, as we shall show in later chapters.

For nonspinning rockets a common means of preventing, or at least of restraining, a yawing motion is by the use of fins at the rear end of the rocket. These fins play a role analogous to the feathers on an arrow. When the rocket becomes yawed, so that it is moving crosswise through the air, the wind action on the fins at the rear tends to push them back into line and so restores the rocket to head-on flight. The net result is that for fin-stabilized rockets a yawing motion is usually oscillatory in nature; in fact, the rocket rotates back and forth in some plane as though it were a pendulum performing simple harmonic oscillations.

A rocket can yaw in two different planes at once. Commonly the yawing motions in the two planes will be out of phase. The result is a sort of corkscrew motion of the rocket, known as "conical yaw." Since this gyration is compounded of two simple harmonic yawing motions, one in each of two different planes, it will suffice to work out the equations of motion for yawing in a single plane.

✓ In this plane we fix an axis of reference. We denote by ϕ the angle between the reference axis and the longitudinal axis of the rocket, and by θ the angle between the reference axis and the direction of motion of the rocket. We denote by δ the angle between the longitudinal axis of the rocket and the direction of motion of the rocket. Then δ is the angle of yaw, and we have

$$\delta = \phi - \theta \quad (\text{I.1.22})$$

These angles are illustrated in Fig. I.1.4. One designates the positive and negative directions for ϕ , θ , and δ in such a way that all three are positive for the configuration shown in Fig. I.1.4.

Yawing motion consists of rotation about an axis through the center of gravity and perpendicular to the longitudinal axis. Such an axis is called a "transverse axis," and the radius of gyration about this axis is called the "transverse radius of gyration." We shall denote it by k . Although k has already been used for one of the other radii of gyration, no confusion will result.

We proceed to apply Principle V. The moment of momentum of the rocket is $Mk^2\dot{\phi}$. Since we are now dealing with a nonspinning

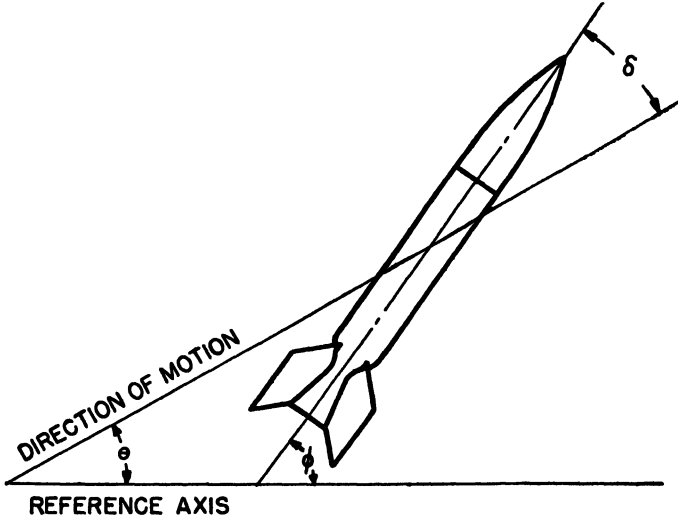

FIG. I.1.4.—Angular coordinates for a yawing rocket.

rocket, we assume that the nozzle (or nozzles) has no cant. Thus the sidewise component of velocity of the gas issuing from the nozzle is just $r_s\dot{\phi}$, where r_s is the distance from the center of gravity of the rocket to the exit of the nozzle. Then the nozzle is removing moment of momentum from the system at the rate $\dot{m}r_s^2\dot{\phi}$. The moment of the pressure forces due to jet action is zero, because the nozzle has no cant. The aerodynamic torques we shall denote by J_a and any other torque forces by J . So we get finally

$$\frac{d}{dt}(Mk^2\dot{\phi}) + \dot{m}r_s^2\dot{\phi} = -J_a - J \tag{I.1.23}$$

We put

$$\frac{d}{dt}(Mk^2\dot{\phi}) = -\dot{m}k^2\dot{\phi} + M\dot{\phi}\frac{d}{dt}k^2 + M k^2\ddot{\phi}$$

We are probably justified in neglecting $M\dot{\phi}(d/dt)k^2$. We do so, and get

$$Mk^2\ddot{\phi} = -\dot{m}\phi(r_s^2 - k^2) - J_a - J \tag{I.1.24}$$

Earlier, when we were going from (I.1.5) and (I.1.6) to the approximate equations (I.1.7) and (I.1.8), we found it justifiable to neglect the term $\dot{m}\omega(r^2 - k^2)$. In the present case, it is probably not permissible to neglect the analogous term

$$\dot{m}\phi(r_0^2 - k^2) \quad (\text{I.1.25})$$

in (I.1.24), since it is of the same order of magnitude as J_α and J .

Since M , \dot{m} , k^2 , and $(r_0^2 - k^2)$ are positive, the term (I.1.25) in (I.1.24) tends to give $\ddot{\phi}$ a different sign from $\dot{\phi}$. That is, the effect of (I.1.25) is to decrease the absolute value of $\dot{\phi}$, or in other words to slow up the rate of rotation. For this reason, (I.1.25) is referred to as a "jet damping term." It has the effect of helping to damp out any yawing motion.

We see that if we should try to combine the simple physical picture of the preceding section with the analogue of Principle III, we should wind up with an equation from which the jet damping term would be missing. So it is not permissible to use the analogue of Principle III when dealing with yawing motion.

Let us pause to review the status of the analogue of Principle III. It does not give the jet damping term when applied to yawing motion. It also fails to give the term $\dot{m}\omega(r^2 - k^2)$, analogous to the jet damping term, when applied to spinning motion. However, the jet damping term cannot be neglected for yawing motion, whereas the analogous term can usually be neglected for spinning motion. So we conclude that one cannot use the analogue of Principle III for yawing motion, although it is usually permissible to use it for spinning motion.

We call attention to one tacit assumption made in deriving the formula for jet damping. When we gave the sidewise component of velocity of the gas issuing from the nozzle as $r_0\phi$, we were assuming that the gas was going "straight" through the nozzle. Actually, this has not been proved so far as we know. The rocket walls have a sidewise motion of $r_0\phi$, but it needs to be shown that the main stream of gas going through the nozzle shares this sidewise motion. One can make a rough argument as follows: Until the gas reaches the throat of the nozzle, it is moving more slowly than the speed of sound. Hence disturbances, such as the yawing motion of the rocket, can be propagated into the gas stream faster than they are swept downstream by the gas flow. Consequently, we may expect the gas stream as a whole to participate in the yawing motion of the rocket until it reaches the throat of the nozzle. Thereafter, the gas is going faster than the speed of sound and probably leaves the nozzle without acquiring any additional sidewise motion. Thus the sidewise motion of the gas is

probably $r_i\phi$, where r_i is the distance from the center of gravity of the rocket to the throat of the nozzle. This is multiplied by $\dot{m}r_e$, and so we conclude that probably r_e^2 should be replaced by $r_i r_e$ in (I.1.23), (I.1.24), and (I.1.25).

Actually, it would not be difficult to perform an experiment that would settle the question of what value to use for r_e^2 in the jet damping term. Suppose we build a two-way rocket with a nozzle at each end. The two nozzles are to be precisely similar, so that when the rocket is fired there is no resultant thrust. We put an axle crosswise through the mid-point of the rocket and mount the axle in bearings so that the rocket can turn end over end. Finally, we set the rocket whirling end over end and fire it. The decrease in moment of inertia due to the loss in mass will tend to increase the rate of whirl and the jet damping will tend to decrease the rate of whirl. By careful measurements of the rate of whirl before and after firing, a quantitative measure of jet damping can be made. By use of a stroboscopic motion camera synchronized with the whirling rocket, the change in rate of whirl can be measured very accurately, and one should be able to measure the jet damping to within 10 per cent or better.

Various precautions will occur to the experimenter, such as whirling the rocket in opposite directions on successive trials to average out any effects due to accidental malalignment of the rocket nozzles.

Despite the simplicity of this experiment, it has never been performed in this country. In fact the whole question of jet damping has received little attention.

We recently read a report of the postwar questioning of a German rocket expert by an Army intelligence officer. According to the report, it was current German practice to take account of jet damping. Unfortunately, the report did not indicate the value of r_e^2 that was used and did not say whether the Germans had made any experimental determination of the jet damping term or depended on theory alone.

We are thus compelled to leave the reader with jet damping in an unsettled status. For the purposes of the present book, we accept the formulas (I.1.23), (I.1.24), and (I.1.25) as giving the effect of jet damping, provided one replaces r_e^2 by $r_i r_e$.

2. The Aerodynamic Forces on a Nonspinning Rocket

Designation of the Forces.—From now on, we shall be dealing with a nonspinning rocket, which, however, may be yawing. We recall the angles ϕ , θ , and δ which were defined for use in this situation (see Fig. I.1.4). We also use v , the velocity of the rocket, d , the

diameter of the rocket, and ρ , the density of the air. We will use K_D , K_L , K_S , K_M , and K_H to designate dimensionless coefficients connected with the various aerodynamic effects that we now cite.

The rocket is subjected to three aerodynamic forces and two aerodynamic torques, or couples. They are

a. The drag,

$$D = -K_D \rho d^2 v^2 \quad (I.2.1)$$

This acts through the center of gravity and is opposed to the direction of motion of the rocket, hence the minus sign in (I.2.1).

b. The lift, or cross-wind force,

$$L = K_L \rho d^2 v^2 \sin \delta \quad (I.2.2)$$

This acts through the center of gravity and is perpendicular to the direction of motion of the rocket. With the rocket configuration as shown in Fig. I.1.4, L would be upward and to the left.

c. The cross-spin force, or pitching force,

$$S = K_S \rho d^3 v \phi \quad (I.2.3)$$

This acts through the center of gravity and is perpendicular to the longitudinal axis of the rocket. With the rocket configuration as shown in Fig. I.1.4, S would be upward and to the left in case ϕ is positive.

d. The restoring moment,

$$M = -K_M \rho d^3 v^2 \sin \delta \quad (I.2.4)$$

This is a moment or couple tending to decrease the numerical value of δ , hence the minus sign in (I.2.4).

e. The damping moment,

$$H = -K_H \rho d^4 v \phi \quad (I.2.5)$$

This is a moment or couple tending to decrease the numerical value of ϕ , hence the minus sign in (I.2.5).

For stable rockets, all of K_D , K_L , K_S , K_M , and K_H are positive. For unstable rockets, K_S and K_M are negative, but the rest are positive.

It is unfortunate that M is also used for the mass of the rocket. However, the use of M to denote the restoring moment is confined to the present section, so that no confusion should result.

The Physical Background.—We propose to give some elementary physical reasoning to justify the various aerodynamic effects just cited.

The reasoning on the drag goes back to Sir Isaac Newton. An excellent discussion is given in Reference 12, pages 86 and 87, and we paraphrase it.

(9) The drag law was derived by Newton from a momentum theorem: The force exerted by the fluid on the body is equal to the rate of change of momentum in the fluid due to the motion of the body.

Newton assumed instead of air or water a hypothetical medium of the following properties: The space around the rocket is filled with a large number of particles having mass but no size. These particles are at rest and are not connected to each other, nor do they exert any influence whatever on each other. The rocket moving through this medium experiences impacts from all the particles in its path and consequently imparts momentum to them. The total mass of all the particles coming to impact with the rocket per second is $\rho v \pi d^2 / 4$. This mass is given a velocity v' , which is proportional to the velocity v of the rocket. The amount of momentum created per second, which has to be equal to the resistance or drag of the rocket, thus becomes

$$D = - \left(\frac{\rho v \pi d^2}{4} \right) v' = -K_D \rho d^2 v^2$$

For rockets of the same shape, K_D is reasonably independent of ρ and d . However, K_D is dependent on the shape of the rocket. One would expect this from our reasoning above. If the rocket has a blunt nose, the air has to move aside faster to get out of the way than it does if the rocket has a sharp-pointed nose and so gets more momentum. Thus one is led to expect more drag from a blunt-nosed rocket than from a sharp-nosed rocket. Within limits this is so.

For low velocities, K_D is fairly independent of v . However, when the rocket approaches the velocity of sound, it becomes very hard for the air to get out of the way fast enough, and so K_D increases suddenly when v gets to the velocity of sound.

K_D also depends on the yaw. This is understandable, since when the rocket is yawed it must disturb a greater volume of air because of being turned somewhat crosswise instead of head-on. By symmetry, we see that the dependence on yaw must be of the form

$$K_D = K_{D_0}(1 + K_{D_\delta} \delta^2) \quad (I.2.6)$$

More precisely, the reasoning runs as follows: Clearly there would be the same drag for a positive yaw δ as for the corresponding negative yaw $-\delta$. Thus K_D is an even function of δ . So the power series expansion of K_D contains only even powers of δ . For small δ , we neglect all terms of this power series except the constant term and the term in δ^2 and thus get (I.2.6).

Actually, in (I.2.6), K_{D_δ} is fairly small, so that it is often sufficiently accurate to consider K_D as independent of δ .

For the explanation of the lift and restoring moment, we first consider the special situation in which the rocket is moving in a straight line with a fixed yaw. That is, δ is constant but not zero and ϕ is zero. Actually this situation is not one of equilibrium and occurs only in wind tunnels where the rocket is held in such a situation for the purpose of measuring lift and restoring moment.

As we noted earlier, a yawed rocket disturbs more air than a head-on rocket. This produces more drag, and it also produces lift and restoring moment. When the rocket is head-on, it is symmetric about the line of flight, and so "by symmetry" the lift and restoring moment must be zero. However, when the rocket is yawed, the rear end of it is exposed to the air stream on a slant and so is pushed sidewise, producing lift and restoring moment.

For lift, one could try to apply a momentum argument similar to that which we gave for drag. If one did so, one would come out with a factor of $\sin^2 \delta$ instead of the $\sin \delta$ that occurs in (I.2.2). Furthermore, the resulting theoretical value of K_L would be far smaller than the experimental value of K_L . Thus the simple Newtonian picture is too oversimplified to be applicable. Actually, viscous forces come into the lift much more than into the drag, and we have to pay far more attention to momentum interchange between the molecules which sweep past the rocket and those which actually collide with it, in particular those which rebound off the rear because of thermal agitation. As a result, the theory is quite complicated. The reader who is interested in a more detailed picture can consult Chap. VI of Reference 12, which contains much relevant information, despite the fact that it deals with the lift of airfoils only.

Nevertheless, one can make a roughly plausible justification of (I.2.2). In the first place, for a rocket with fixed yaw and fixed proportions moving in a straight line, the lift must depend only on ρ , δ , v , and some linear dimension such as d . Since lift has the physical dimensions of a force, ρ , v , and d must enter into (I.2.2) in such a way as to give the dimensions of a force. A little trial readily shows that only the combination $\rho d^2 v^2$ will give the dimensions of a force. We have now to multiply this by K_L and a function of δ . If we reverse the sign of δ , it is clear that we merely take a mirror image of the original situation, so that we must reverse the sign of L . Thus L is an odd function of δ . Consequently, if we can expand L as a power series in δ , we have only odd powers of δ , and so for small δ we can neglect all but the first power of δ , thus getting (I.2.2).

For rockets of the same shape, K_L is reasonably independent of ρ and d . Naturally, K_L depends on the shape of the rocket, particu-

larly on the size, number, and arrangement of fins. For low velocities, K_L is fairly independent of v . The behavior of K_L at or above the speed of sound is not really known yet.

For small δ , K_L is fairly independent of δ . We should note that any particular rocket constructed by the usual methods of mass production is seldom perfectly accurately constructed. As a result, it fails to have exact symmetry. Thus the lift force will not be zero when $\delta = 0$, as it should, but when $\delta = \delta_L$. Thus we have to replace (I.2.2) by

$$L = K_L \rho d^2 v^2 \sin(\delta - \delta_L) \quad (\text{I.2.2}^*)$$

As a preliminary step in considering the restoring moment, we appeal to symmetry to conclude that the resultant of all forces and couples on the rocket lies in the plane of yaw. That is to say, in Fig. I.1.4, the resultant force and resultant couple both lie in the plane of the figure. To see this, we note that conditions in front of the plane of the figure are just the mirror image of conditions behind this plane. By combining all the forces in mirror-image pairs, the resultant force and resultant couple are easily seen to lie in the plane of the figure.

When the resultant force and resultant couple lie in the same plane, one can replace them by a single force—not through the center of gravity—and no couple. The point on the longitudinal axis of the rocket through which this single force passes is called the “center of pressure.”

In particular, we have replaced the restoring moment plus the drag and lift through the center of gravity by simply the drag and lift through the center of pressure, the center of pressure being so located that the moment produced by the drag and lift through this off-center point is just equal to the restoring moment.

6) For a stable rocket, for which K_M is positive, the center of pressure is to the rear of the center of gravity. For an unstable rocket, for which K_M is negative, the center of pressure is in front of the center of gravity. We denote the distance from the center of gravity to the center of pressure by l , taking l as positive when the center of pressure is to the rear of the center of gravity, and as negative in the reverse case.

It is now very easy to compute the restoring moment. The drag gives a couple equal to $Dl \sin \delta$ and the lift gives a couple equal to $-Ll \cos \delta$. By (I.2.1) and (I.2.2), we get

$$M = -(K_D + K_L \cos \delta) \rho d^2 l v^2 \sin \delta \quad (\text{I.2.7})$$

We see that this has the form of (I.2.4), and that in fact one has

$$K_M = \frac{(K_D + K_L \cos \delta)l}{d} \quad (\text{I.2.8})$$

In wind-tunnel measurements, where K_D , K_L , and K_M are measured directly, the relation (I.2.8) is used to compute the value of l .

The center of pressure and the distance l are reasonably constant over considerable ranges of ρ , d , v , and δ . Thus, for rockets of the same shape, K_M is reasonably independent of ρ and d . Then from (I.2.8), we see that l is proportional to d , quite appropriately, and is independent of ρ . Naturally, K_M and l depend on the shape of the rocket, particularly on the size, number, and arrangement of fins. For low velocities, K_M and l are fairly independent of v . The behavior of K_M and l at or above the speed of sound is not really known yet.

For small δ , K_M and l are fairly independent of δ . However, for larger δ , K_M and l will usually decrease rapidly as δ increases, even becoming negative for large δ . The value of δ at which K_M and l begin to decrease depends on the shape of the fins and varies perhaps from 5 to 15°.

For nonsymmetric rockets, particularly those which have had fins bent by careless handling, the restoring moment is not zero when $\delta = 0$ but when $\delta = \delta_M$. Thus we have to replace (I.2.4) by

$$M = -K_M \rho d^3 v^2 \sin(\delta - \delta_M) \quad (\text{I.2.4}^*)$$

In spite of the relation (I.2.8), there is no obvious connection between δ_L and δ_M .

If we have a rocket of changing yaw, then there must be other aerodynamic forces besides the drag and lift. This was pointed out by K. L. Nielsen and J. L. Synge, their argument being as follows: Consider two rockets of precisely similar external shape with the same instantaneous motion. Then the total aerodynamic forces on each must be the same. Suppose that the two rockets have a different distribution of internal mass, so that they have different centers of gravity. Then, because of the changing yaw, the centers of gravity of the two rockets will be moving in different directions, so that the two rockets have different values of θ . However, they have the same values of ϕ , since they are externally identical. Thus they have different angles of yaw and so by (I.2.2) would have different lift forces. So if there were no sidewise aerodynamic force except lift, the two rockets would not have identical total aerodynamic forces acting on them.

Accordingly there must be some sidewise force dependent on ϕ . A similar argument shows the necessity for a torque or moment dependent on ϕ . This side force and torque will turn out to be the cross-spin force and damping moment, of course, and we proceed to see in detail just what form these should have.

Clearly the center of pressure is more basic for computing aerodynamic effects than is the center of gravity. So we can conjecture that the total lift and restoring moment are determined not by the true yaw δ , which is the angle between the longitudinal axis of the rocket and the direction of motion of the center of gravity, but by an effective

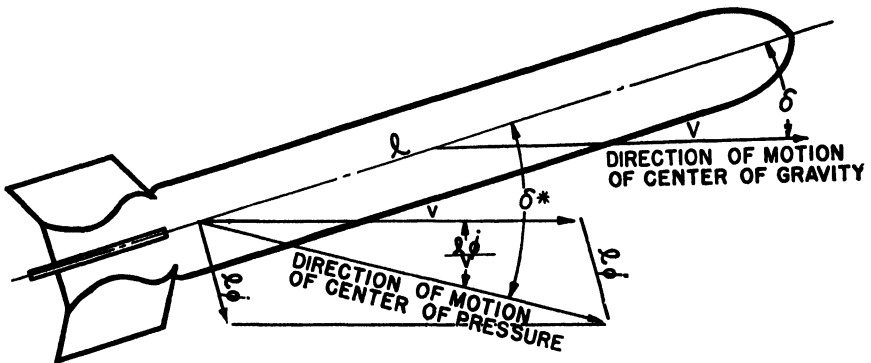

FIG. I.2.1.—Determination of yaw in terms of center of pressure instead of center of gravity.

yaw δ^* , which we define as the angle between the longitudinal axis of the rocket and the direction of motion of the center of pressure.

Since our final result is only qualitative, we make free use of various approximations such as putting

$$\begin{aligned}\cos \delta &= \cos \delta^* = 1 \\ \sin \delta &= \delta \\ \sin \delta^* &= \delta^*\end{aligned}$$

and the like (angles are in radians).

The center of pressure is revolving about the center of gravity at a speed of $l\phi$. By compounding this motion with the forward motion of the center of gravity (see Fig. I.2.1), we get the resultant motion of the center of pressure. Thus, with angles in radians, we get as a reasonable approximation,

$$\delta^* = \delta + \frac{l\phi}{v}$$

So by (I.2.2) and (I.2.4) the effective lift and effective restoring

moment are given by

$$L^* = K_L \rho d^2 v^2 \left(\delta + \frac{l\phi}{v} \right) \quad (\text{I.2.9})$$

$$M^* = -K_M \rho d^2 v^2 \left(\delta + \frac{l\phi}{v} \right) \quad (\text{I.2.10})$$

Now we conceive of L^* as being composed of the lift due to the amount of yaw, plus the cross-spin force due to the changing of the yaw. That is,

$$L^* = L + S$$

Combining this with (I.2.9) and (I.2.2), we get

$$S = K_L \rho d^2 l v \phi$$

This gives us (I.2.3) by putting

$$K_S = \frac{K_L l}{d} \quad (\text{I.2.11})$$

We proceed similarly with M^* . By (I.2.10) it also is composed of two parts, one due to the amount of yaw and the second due to the changing of the yaw. We identify the first with M and apply (I.2.4). We identify the second with H and so deduce

$$H = -K_M \rho d^2 l v \phi$$

This gives us (I.2.5) by putting

$$K_H = \frac{K_M l}{d} \quad (\text{I.2.12})$$

In deriving (I.2.11) and (I.2.12), we have oversimplified the picture, not once but many times. Accordingly, these two equations are quite unreliable, as will appear from the numerical example which is to follow. In any case, (I.2.12) must surely be wrong for the special case where the center of pressure happens to coincide with the center of gravity, since it would then predict $K_H = 0$, whereas K_H is always positive. Nevertheless, the considerations leading to (I.2.11) and (I.2.12) are useful in deriving qualitative results. By applying the above reasoning to portions of the rocket separately, such as fins and body, one can obtain more reliable formulas than (I.2.11) and (I.2.12).

A Typical Set of Data.—For rockets it is common to measure K_D , K_L , and K_M in a wind tunnel, because these coefficients can be measured by holding the rocket fixed in the wind stream and measuring two forces and a torque. All wind tunnels are equipped to make such measurements. To measure K_S and K_H requires that one have a wind tunnel equipped to make "dynamic" measurements, that is,

measurements in which readings are taken while the rocket is allowed to oscillate in the wind stream. For this, much more elaborate equipment is needed, and few wind tunnels are so equipped. Among the rockets for which K_S and K_H have been measured is the Army M8. This round is obsolescent, so that we are permitted to quote the data for it. They are

$$\begin{aligned}d &= 4.5 \text{ in.} \\K_D &= 0.204 \\K_L &= 2.33 \\K_M &= 6.32 \\K_S &= 20.4 \\K_H &= 31.6\end{aligned}$$

By (I.2.8), taking $\cos \delta = 1$, we get

$$\begin{aligned}\frac{l}{d} &= 2.50 \\l &= 11.25 \text{ in.}\end{aligned}$$

Then (I.2.11) and (I.2.12) would give

$$\begin{aligned}K_S &= 5.82 \\K_H &= 15.8\end{aligned}$$

Thus we see that (I.2.11) and (I.2.12) are off by a factor of 2 or 3 in this case.

We proceed to more details. The variation of K_D with δ is given by

$$K_D = 0.204 + 4.37\delta^2$$

[see (I.2.6)]. Here and throughout, angles are in radians unless expressly stated otherwise. We see that even for a large yaw, such as 0.1 rad, the increase in K_D is not striking.

The value of δ_L [see (I.2.2*)] is -0.0101 , so that we have

$$L = 2.33\rho d^2 v^2 \sin(\delta + 0.0101)$$

The value of δ_M [see (I.2.4*)] is 0.016 , so that we have

$$M = -6.32\rho d^3 v^2 \sin(\delta - 0.016)$$

Rockets are not intentionally constructed so as to have values of δ_L and δ_M different from zero. However, when rockets are mass produced, perfect symmetry is seldom attained, so that for a set of supposedly identical rockets one would expect values of δ_L and δ_M distributed randomly about zero.

We should point out that the values quoted above for δ_L and δ_M are

probably due to idiosyncracies of the particular wind tunnel in which the model was tested as much as to asymmetry of the model itself. Different values might result from measuring the same model in a different wind tunnel. Nevertheless, they are typical values, and we shall proceed as though they were quite reliably measured.

We have given three significant figures in the above data, for uniformity with the report from which they are taken. However, the reader must not conclude that the data are really known with any such accuracy. On the contrary, it is unlikely that any of the data quoted (except d) are correct to nearer than 5 per cent, and at least one of the items (namely, K_s) may be off by as much as 50 per cent. Such data as K_L and δ_L or K_M and δ_M are obtained by fitting a straight line by least squares to a graph of lift or restoring moment plotted against yaw. This graph deviates markedly from a straight line for large yaw, and so we fitted only that portion which seemed fairly straight. Other workers have gotten somewhat different values of K_L and K_M from the same data by fitting a somewhat different portion of the graph with a straight line.

Such a lack of precision seems characteristic of aerodynamic data.

The coefficients K_D and K_M are sometimes determined by measurements taken during flight. To determine K_D , one makes accurate measurements of the deceleration of the rocket in flight. For this purpose one can use the same methods of measurement that have been developed for measuring K_D for shells (see Reference 6, Chap. 8). To measure K_M , use is made of a fact that we will prove later. This is that when a rocket yaws, its period of oscillation is inversely proportional to the velocity. As a result, a rocket will traverse the same distance while performing an oscillation, regardless of velocity. This distance, for a complete cycle of oscillation, is called the "wave length of yaw" and is denoted by σ . If M is the mass of the rocket and k is the radius of gyration about a transverse axis through the center of gravity, then, as we will show later,

$$\sigma = 2\pi \sqrt{\frac{Mk^2}{K_M \rho d^3}} \quad (\text{I.2.13})$$

To measure σ , one photographs a yawing rocket in flight. Then, by measuring the film, the distance traversed during each oscillation can be determined, and this is σ . For a single oscillation such a measurement will be quite inexact, but over several oscillations one can get a fairly accurate value of σ . Then, by (I.2.13), K_M is readily computed.

This method could be used over quite a large range of values of v ,

by taking a number of rockets that are externally similar and loading them so as to achieve different velocities after burning. If systematic experiments of this sort were performed for a variety of rockets over a wide range of velocities, much useful information could be obtained about the variation of K_M with fin shape and velocity.

Effect of Jet Action.—There is one question that has never been adequately answered. This is the question whether the aerodynamic effects are the same when the jet is operating as when it is not. We proceed to summarize the best available information on this subject.

Consider first the drag. According to a more sophisticated picture of the drag than that we gave earlier, the drag is composed of three parts, nose drag, skin friction, and tail drag. Because of the rocket's flight through the air, air molecules tend to "pile up" around the nose of the rocket, so that the pressure over the nose is above atmospheric pressure. This increase of pressure at the nose produces the nose drag. At the rear, the air molecules cannot rush into the empty space left by the flying rocket fast enough to maintain full atmospheric pressure on the rear of the rocket. Thus there is a suction effect at the rear, producing the tail drag. The skin friction, as its name indicates, is the friction of the sides of the rocket with the air stream slipping past.

Nose drag is probably unaltered by jet action. For skin friction, the effect is difficult to assess. The jet action may shift the separation point of the boundary layer along the sides of the rocket, thereby changing the skin friction, but it is hard to make any precise estimates. Probably there is little or no change in the skin friction for most rocket shapes.

In the case of tail drag, the picture is quite clear. In place of the suction that would occur at the rear with no jet action, there is the jet pressure. As we noted earlier, this jet pressure is independent of exterior conditions such as velocity. As a result, tail drag disappears completely when the jet is acting. At low speeds this means a considerable decrease in drag, perhaps as much as 30 per cent in extreme cases. However, at low speeds the drag is not great. At high speeds, especially above the speed of sound, the nose drag becomes much greater than the skin friction and tail drag, so that the proportional decrease in drag due to jet action is much less.

We should remark that these variations of drag due to jet action are usually of little consequence for conventional rockets. This is because the main effect of drag when the jet is operating is in opposition to the jet forces, and the jet forces are usually much greater than the drag. Therefore, minor variations of the drag have little effect.

Naturally, we are not speaking of such contraptions as a jet-propelled airplane, where the jet forces just balance the over-all drag for steady flight. Our analysis of the drag applies only to wingless projectiles and should not be extended to more complex devices. Moreover, our remarks about the effect of the jet on the tail drag must be modified if the exit of the jet is only a small fraction of the tail area.

One could presumably determine the effect of jet action on K_M by measuring the wave length of yaw [see (I.2.13)] both during and after burning. Such measurements have not indicated any variation of K_M due to jet action. However, we should warn the reader not to put too much reliance on this result. As indicated earlier, to get an accurate determination of σ requires measurements over a considerable distance, amounting to many wave lengths of yaw. Most rockets do not burn that long. In an attempt to improve the accuracy, the angles of yaw were measured from the films, and then the graph of angle versus distance was fitted with a sine curve. However, no careful analysis has been made of the accuracy obtainable by this procedure, and it is doubtful how trustworthy the results are. Nonetheless, present opinion inclines to the belief that K_M is unaltered by jet action, although this has not been fully established.

No information is available about the effect of jet action on K_L , K_S , or K_H . As is usual in such cases, one makes the simplest possible assumption, namely, that there is no effect of jet action.

3. Definition of Coordinate Systems

It is no part of our intention to derive the completely general equations of motion of a rocket. In particular, we will not give any equations for fast-spinning rockets. Such equations could be derived by Principle V after the necessary aerodynamic data have been furnished. However, the difficulties involved are mostly those having to do with gyroscopic effects and such complications which are presumably familiar from shell ballistics. The effects due to jet action alone will be sufficiently elucidated by our earlier discussions and by our treatment of the nonspinning rocket.

To be explicit, we shall assume that our rocket is nonspinning or at least is spinning sufficiently slowly so that gyroscopic effects and aerodynamic effects dependent on spin can be ignored.

As a further simplification, we shall assume that our rocket is fairly symmetric about its longitudinal axis. In particular, we shall assume that the coefficients K_D , K_L , K_S , K_M , and K_H are independent of the orientation of the rocket about its longitudinal axis. This is reasonably true of most rockets. Some wind-tunnel tests have

shown variations of the coefficients with the orientation of the rocket. However, in such tests, the rocket was suspended on a spindle protruding sidewise from the rocket (see Fig. I.3.1). Thus the air stream is disturbed by the spindle before it gets to the fins, and so one might expect the measurements to vary according to the relative positions of the spindle and fins. One test was made with a rear support (see

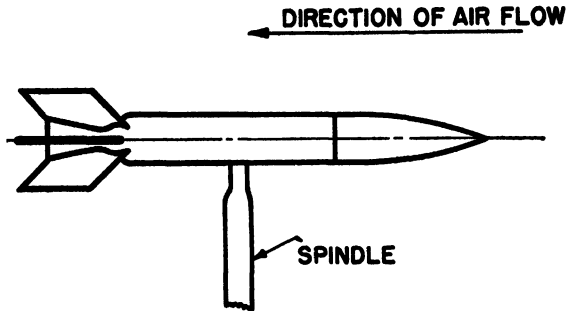

FIG. I.3.1.—Usual type of support for a rocket in a wind tunnel.

Fig. I.3.2), and in this test the measurements were scarcely affected by the orientation of the fins. We cite this test as evidence that the coefficients K_D , K_L , K_S , K_M , and K_H are independent of the orientation of the rocket. It would be advisable if further tests of this sort were made.

The quantities δ_L and δ_M , which are a measure of the asymmetry of the rocket, will depend on the orientation of the rocket. We assume that there is an orientation that gives a maximum value of δ_L , and

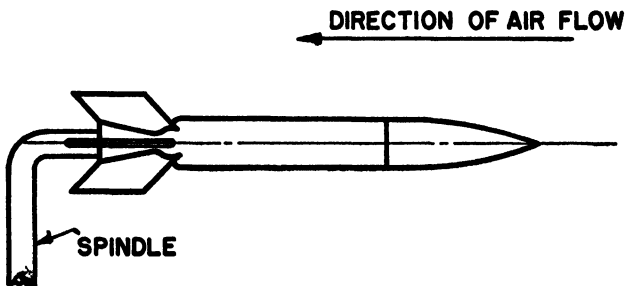

FIG. I.3.2.—Alternative type of support for a rocket in a wind tunnel.

that for any other orientation one merely has to take the appropriate component of δ_L . Similarly for δ_M .

Our final approximation is to assume that the actual yawing motion of the rocket can be compounded of distinct yawing motions in two perpendicular planes. This assumption is reasonably good, but we feel that it is only fair to point out the various minor deviations from

exactness involved in the assumption. For one thing, the motion of the center of gravity cannot remain in two perpendicular planes. To do so, it would have to remain in their intersection, which is a straight line. However, rockets do not travel in straight lines. Under the influence of gravity, the trajectory curves earthward. So our two perpendicular planes must continually change their tilt to match the direction of the trajectory. However, this change is very slow compared with the yawing oscillations that will be our main preoccupation. Thus it is fair to pretend that our two perpendicular planes have a fixed orientation.

The second point is that if the rocket yaws out of a given plane, its projection on the given plane will be foreshortened a bit. Hence the effective distance l between the center of gravity and center of pressure will be decreased a bit. This presumably changes K_M [see (I.2.8)], and therefore σ [see (I.2.13)]. So, if the rocket is yawing in each of two perpendicular planes, the yawing in one plane will change the coefficients in the other plane. However, these changes will depend on the cosine of the angle of yaw. For small yaw, say $|\delta| \leq 0.1$ rad, this cosine is equal to unity to within $\frac{1}{2}$ per cent. We do not know the coefficients well enough to be concerned with variations of $\frac{1}{2}$ per cent.

There are other minor details, such as minute gyroscopic effects in one plane due to yawing in the second plane. These are far too small to worry about.

To reiterate, we are assuming that the actual yawing motion of the rocket can be compounded from distinct yawing motions in two perpendicular planes. Thus it suffices to restrict attention to the components of motion in a single plane.

We shall now characterize this plane (not forgetting that there should be two such planes perpendicular to each other). The plane should "contain" the trajectory of the rocket. As we said earlier, this is not strictly possible, since the trajectory would have to be a straight line if it is to be contained by each of two perpendicular planes, whereas actually the trajectory has a general over-all curvature and a great many small wiggles. However, if we restrict attention to a limited portion of the trajectory, the over-all curvature will not make the trajectory deviate too markedly from a straight line. Also the wiggles are small, and we shall ignore them. Thus we can choose a straight line that will approximate this portion of the trajectory reasonably well. Such a line will be called an "approximate trajectory." We impose the condition that our plane must contain some suitably chosen approximate trajectory.

The two most convenient planes that contain a given approximate

trajectory are the vertical plane through it and the plane through it that is perpendicular to the vertical plane (see Fig. I.3.3). The vertical plane will be particularly useful, since it is usually possible to choose a single vertical plane that will contain approximate trajectories lying all along the actual trajectory. That is, in dealing with the vertical components of motion, one can usually deal with the entire trajectory at one time. However, to deal with the horizontal components of motion for a trajectory of considerable length, one will usually need a succession of planes perpendicular to the vertical plane, each successive plane containing an approximate trajectory corresponding to each successive portion of the actual trajectory. Alter-

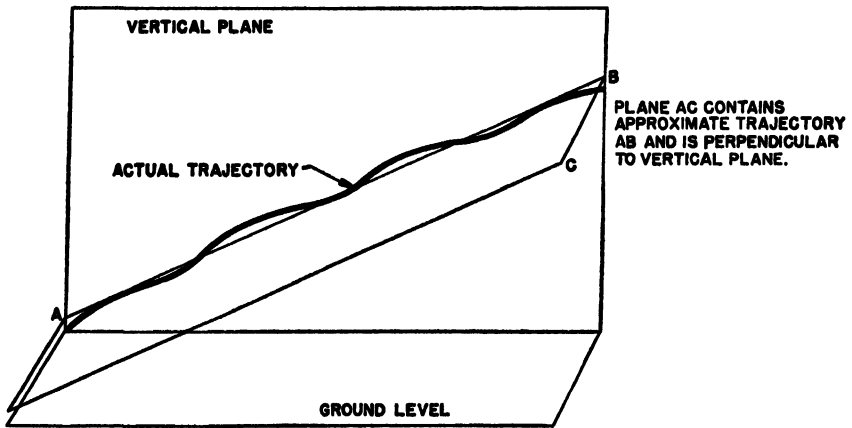

FIG. I.3.3.—Mutually perpendicular planes nearly containing trajectory.

natively, one sometimes uses a slowly turning plane perpendicular to the vertical plane, the slowly turning plane to be moving so as to contain a very closely approximate trajectory at each point. In a general manner of speaking, one might say that one uses a moving plane that stays perpendicular to the vertical plane and is tangent to the trajectory at the (moving) position of the rocket. However, this is not strictly true, since if the plane were strictly tangent to the trajectory, it would have to fluctuate violently to accommodate the small wiggles in the trajectory. Instead, the plane is to be tangent to the trajectory in an "average" fashion.

The plane perpendicular to the vertical plane is often miscalled the "horizontal plane." Those who speak so are not under any misapprehensions that the plane is genuinely horizontal. However, the plane is often nearly horizontal, and so it is a descriptive, if loose, way of speaking.

Having characterized the plane in which we shall consider that the

motion takes place, we set up a coordinate system therein. This coordinate system will be fixed relative to the air for convenience in dealing with the aerodynamic forces. In case there is a wind, the coordinate system will move relative to the ground, so that transition to ground coordinates will involve a transformation of coordinates. In such case, a constant wind velocity is assumed.

To specify the position of the rocket in the plane, we need the coordinates (x, y) of the center of gravity. To specify the motion, one could use the time derivatives of x and y , but it is more convenient to use the velocity v of the center of gravity and the angle θ which the tangent to the trajectory makes with a reference axis (see Fig. I.1.4). It is usual to take this reference axis to be the x axis. Then we have

$$\dot{x} = v \cos \theta \quad (\text{I.3.1})$$

$$\dot{y} = v \sin \theta \quad (\text{I.3.2})$$

To specify the orientation of the rocket, we use first of all the angle ϕ which the longitudinal axis of the rocket makes with the reference axis (see Fig. I.1.4). In the case of a symmetric rocket, no further specification of orientation is needed. For an unsymmetric rocket, one must further specify the orientation of the rocket about its longitudinal axis. For this we use an angle ψ as a measure of rotation about the longitudinal axis.

For changes in orientation, we can specify the time derivatives, $\dot{\phi}$ and $\dot{\psi}$, of ϕ and ψ .

Useful auxiliary variables are s , the distance traversed along the trajectory, and δ , the angle of yaw.

We proceed to further particulars, such as specifying the positive directions for our various coordinates, etc. This can best be done by reference to Fig. I.1.4, because in preparing Fig. I.1.4 we oriented the rocket so that the variables would have all their plus directions in the familiar directions.

Thus when we choose the reference axis to be the x axis, the plus direction is to the right, as usual. Incidentally, this accords with the accepted ballistic doctrine that the direction of motion is that of increasing x . The plus direction for y is upward, giving the usual xy coordinate system. The position of the origin turns out to be fairly immaterial. We leave it to be assigned at will. The usual plus direction for angles is counterclockwise, and we abide by this, as indicated by our conventions for θ , ϕ , and δ .

For certain purposes it is useful to choose components along and perpendicular to the trajectory. Here we keep the familiar configura-

tion of axes, with the direction of motion serving as the x axis, the plus direction being in the direction of motion. Thus in Fig. I.1.4 the plus direction along the trajectory is upward and to the right and the plus direction perpendicular to the trajectory is upward and to the left. As the direction of the trajectory changes, this configuration of directions should turn with it.

This leaves us with the orientation of ψ to settle. Necessarily, this takes us out of our single plane. Let us imagine ourselves riding upright on the rocket in its flight and looking forward. Then the plus direction of ψ shall be counterclockwise.

We are now nearly ready to quit the tiresome but necessary specification of coordinate systems. All that remains is to acquaint our readers with certain conventions.

In the vertical plane, it is usual to take the reference or x axis as horizontal, and the upward direction to be plus for the y axis.

In the horizontal plane, the reference or x axis is taken to be the approximate trajectory, with the plus direction in the direction of motion. Then we orient the y axis so that when the plane is viewed from above, the x and y axes will present their usual configuration. From the point of view of an observer riding upright on the rocket, the plus y axis in the vertical plane is up and the plus y axis in the horizontal plane is to the left.

4. Gravity

For the present treatment we consider only trajectories for which one can neglect such features as variations of the earth's gravitational attraction with altitude; nonparallelism of the gravitational attraction at different points of the earth's surface; the attraction of sun, moon, and stars; the centrifugal force due to the earth's rotation; etc. That is, we assume a uniform value of g such that a rocket of mass M is subject to a force Mg in a uniform direction, which direction shall be called "downward."

The components of gravitational attraction in the vertical plane are $-Mg \sin \theta$ in the direction of the approximate trajectory and $-Mg \cos \theta$ perpendicular to the approximate trajectory. The components of gravitational attraction in the horizontal plane are $-Mg \sin \theta$ in the direction of the approximate trajectory and zero perpendicular to the approximate trajectory.

5. The Equations of Motion of a Nonspinning Rocket

In deriving our equations, we invoke certain simplifying assumptions. These were discussed in some detail at the beginning of Sec. 3

in order to justify our choice of coordinate systems. We review them briefly. We assume that the rocket is nonspinning, or at least is spinning sufficiently slowly that gyroscopic effects and aerodynamic effects dependent on spin can be ignored, that the rocket is fairly symmetric about its longitudinal axis, and that we can restrict attention to the components of motion in a single plane.

The reader is perhaps expecting that all that remains is to substitute the aerodynamic forces into (I.1.2) and (I.1.24). Unfortunately one further final complication must be considered, namely, the effect of possible malformation of the rocket. In deriving the jet forces, we purposely ignored such facts as that often a nozzle is not quite in line with the axis of the rocket. Actually, if one is to produce a large supply of rockets at a reasonable price, one must be prepared to find that most of the rockets will deviate in small particulars from the prescribed dimensions, and that these deviations will be fairly random. Far from ignoring these deviations, one of the uses of rocket ballistics is to compute the discrepancies in flight caused by them. Then, by choosing the permissible discrepancies in flight, one can determine the permissible deviations in rocket dimensions. From these, one can set up acceptance criteria for the rocket manufacturer.

Since large discrepancies in flight are hardly to be tolerated, no more can large deviations in dimensions be tolerated. So we can reasonably assume that the deviations are small.

In connection with the aerodynamic forces, two deviations have already been considered, namely, the deviations from exact symmetry that are responsible for δ_L and δ_M being different from zero. The remaining deviations that concern us have to do with the jet forces and so involve inaccuracies of nozzle construction.

We pause to make the observation that from a manufacturing point of view the use of many small nozzles has one advantage over the use of a single large nozzle, namely, that one can allow greater inaccuracies in the individual dimensions of the many small nozzles as long as these inaccuracies are random, since no single small nozzle will contribute a large error and the various errors from the different small nozzles will tend to cancel out. However, we shall continue to talk as though there were a single nozzle. In case there are many small nozzles, one can treat the resultant thrust T as being due to a single large nozzle.

There are three types of thrust malalignment that can take place. The thrust may make an angle δ_T with the axis of the rocket, or it may miss the center of gravity by a distance L , or it may supply a

torque tending to spin the rocket about its longitudinal axis at a rate of γ revolutions for each wave length of yaw traveled.

It is unfortunate that L has already been used to denote lift. To avoid confusion, we shall not use L to denote lift from here on.

Mechanically, δ_T and L may arise from a variety of causes. The rocket itself may be bent, or the nozzle may not be centered, or the nozzle may be drilled on a slant, or the end of the nozzle may not be cut off square. With modern machine methods, there is little likelihood of a badly uncentered nozzle. The other three causes lead to a thrust malalignment roughly like that pictured in Fig. I.5.1, which may be taken as typical, though exaggerated.

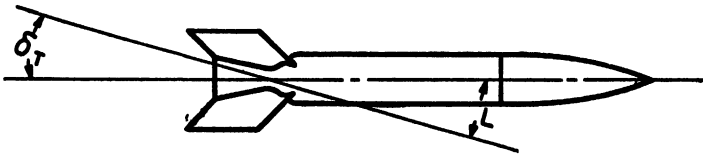

FIG. I.5.1.—Malalignment of thrust, greatly exaggerated.

If the nozzle were drilled on a slant but the end were cut off square, the momentum forces of the jet would be malaligned but the pressure forces would be nearly aligned (slightly off-center at worst). Thus the resultant thrust would be malaligned, though less so than the part of the thrust due to momentum forces. If the nozzle were well aligned but the end were not cut off square, then the pressure forces would be malaligned but the momentum forces would be aligned.

Such refinements of the picture can be left for the rocket manufacturer to worry about. For our purpose, it suffices to know δ_T and L for the resultant thrust.

From Fig. I.5.1, we derive the simple relation

$$L = r_i \delta_T \quad (\text{I.5.1})$$

where we recall that r_i is the distance from the center of gravity of the rocket to the throat of the nozzle. At best, (I.5.1) is approximate, and it will be seriously in error in the few cases of a badly centered nozzle. Nevertheless, the formula is of value in estimating the relative order of magnitude of the effects due to δ_T and L , respectively.

The convention as to signs for δ_T and L is that, for the configuration shown in Fig. I.5.1, both δ_T and L are positive. It is supposed that in Fig. I.5.1 the rocket is being viewed from the same point of observation as in Fig. I.1.4.

For rockets that are not intended to spin, the torque will usually be completely negligible, so that one can safely put $\gamma = 0$. In some

cases, a rocket is purposely given a slow spin. In such case, the value of γ is at the discretion of the designer.

To describe the motion of the rocket, it suffices to express x , y , ϕ , and ψ as functions of the time t .

For nonspinning rockets, ψ is a constant. In Secs. 12 and 13 of Chap. III, we shall estimate the effects of a slow spin by assuming simple forms for ψ as a function of t .

With ψ thus disposed of, we turn to x , y , and ϕ . For their determination, three independent equations will be needed. We obtain these by first applying Principle III in the direction of motion of the rocket, then by applying Principle III perpendicular to the direction of motion, and finally by applying Principle V to the yawing rotation about a transverse axis. It simplifies matters to introduce auxiliary variables v , s , θ , and δ defined by

$$v = \sqrt{(\dot{x})^2 + (\dot{y})^2} \quad (I.5.2)$$

$$v = \frac{ds}{dt} \quad (I.5.3)$$

$$\tan \theta = \frac{\dot{y}}{\dot{x}} \quad (I.5.4)$$

$$\delta = \phi - \theta \quad (I.5.5)$$

First let us take components in the direction of motion of the rocket and apply Principle III. The component of acceleration in this direction is \dot{v} . The jet force is T , applied at an angle δ_r to the axis of the rocket (see Fig. I.5.1). As the axis of the rocket is at an angle δ to the direction of motion (see Fig. I.1.4), the jet thrust is applied at an angle of $\delta - \delta_r$ to the direction of motion. Accordingly, the component of thrust in the direction of motion is $T \cos(\delta - \delta_r)$. The component of gravity is $-Mg \sin \theta$. The components of the aerodynamic forces are the drag $-K_D \rho d^2 v^2$ and the component of the cross-spin force $-K_{s\rho} d^3 v \phi \sin \delta$. Finally there is the component F_1 of any other forces, such as friction with the launcher or the like.

Collecting all these and using Principle III gives

$$M\dot{v} = T \cos(\delta - \delta_r) - Mg \sin \theta - K_D \rho d^2 v^2 - K_{s\rho} d^3 v \phi \sin \delta - F_1 \quad (I.5.6)$$

Now let us take components perpendicular to the direction of motion. The acceleration in this direction is

$$\ddot{y} \cos \theta - \ddot{x} \sin \theta = \dot{y} \frac{\dot{x}}{v} - \dot{x} \frac{\dot{y}}{v} = v \frac{1}{1 + (\dot{y}/\dot{x})^2} \frac{\dot{x}\ddot{y} - \dot{y}\ddot{x}}{(\dot{x})^2} = v\dot{\theta}$$

by (I.5.2) and (I.5.4).

As noted above, the jet thrust is applied at an angle of $\delta - \delta_T$ to the direction of motion. Accordingly, the component of thrust perpendicular to the direction of motion is $T \sin(\delta - \delta_T)$. The component of gravity is $-Mg \cos \theta$ or zero, according to whether we are in the vertical or the horizontal plane. The components of the aerodynamic forces are the lift $K_L \rho d^2 v^2 \sin(\delta - \delta_L)$ and the component of the cross-spin force $K_{sp} \rho d^3 v \phi \cos \delta$. Finally there is the component F_2 of any other forces.

Collecting all these and using Principle III gives

$$Mv\dot{\theta} = T \sin(\delta - \delta_T) - Mg \cos \theta + K_L \rho d^2 v^2 \sin(\delta - \delta_L) + K_{sp} \rho d^3 v \phi \cos \delta - F_2 \quad (\text{I.5.7V})$$

in the vertical plane and

$$Mv\dot{\theta} = T \sin(\delta - \delta_T) + K_L \rho d^2 v^2 \sin(\delta - \delta_L) + K_{sp} \rho d^3 v \phi \cos \delta - F_2 \quad (\text{I.5.7H})$$

in the horizontal plane.

In modifying (I.1.23) to take account of jet malalignment, it suffices to insert the torque TL due to jet malalignment (see Fig. I.5.1) on the right side. To prove this, we proceed as follows:

Because of nozzle malalignment, the gas issuing from the jet will have a sidewise component of velocity relative to the rocket as well as a rearward component. We temporarily denote this sidewise component by v^* . The convention as to sign will be that v^* is positive if it is downward in Fig. I.5.1. In our discussion of jet damping, we decided that the rotation of the rocket causes an additional sidewise velocity of $r_i \dot{\phi}$. Thus the total sidewise component of velocity of the gas issuing from the nozzle is $v^* + r_i \dot{\phi}$. So the nozzle is removing moment of momentum from the system at the rate $\dot{m} r_e (v^* + r_i \dot{\phi})$. Because of nozzle malalignment, the pressure forces over the exit of the nozzle will produce a torque of J_P . Other details are as in the derivation of (I.1.23), and so when we apply Principle V, we get

$$\frac{d}{dt} (Mk^2 \dot{\phi}) + \dot{m} r_e (v^* + r_i \dot{\phi}) = J_P - J_a - J \quad (\text{I.5.8})$$

Now consider the rocket fastened in a test stand. J_a and $\dot{\phi}$ will be zero, and J must be just the torque TL of the rocket jet (see Fig. I.5.1) as measured by the torque gauge in the test stand. So (I.5.8) reduces to

$$TL = J_P - \dot{m} r_e v^*$$

Putting this back into (I.5.8), we get

$$\frac{d}{dt} (Mk^2 \dot{\phi}) + \dot{m} r_e r_i \dot{\phi} = TL - J_a - J$$

This is just (I.1.23) with TL inserted on the right side [the reader will recall that we have already replaced r_s^2 by $r_r r_e$ in (I.1.23)].

We now neglect $M\phi(d/dt)k^2$, and deduce

$$Mk^2\ddot{\phi} = TL - \dot{m}\phi(r_r r_e - k^2) - J_a - J$$

It remains merely to insert the aerodynamic torques, namely, the restoring moment $-K_M \rho d^3 v^2 \sin(\delta - \delta_M)$ and the damping moment $-K_H \rho d^4 v \phi$. There results

$$Mk^2\ddot{\phi} = TL - K_M \rho d^3 v^2 \sin(\delta - \delta_M) - K_H \rho d^4 v \phi - \dot{m}\phi(r_r r_e - k^2) - J \quad (\text{I.5.9})$$

Our three equations for determining x , y , and ϕ are (I.5.6), (I.5.7), and (I.5.9). Actually, the procedure is to use them to determine v , δ , and θ , and then get x , y , and ϕ by (I.5.2), (I.5.3), (I.5.4), and (I.5.5).

Certain simplifying approximations can be made. In $Mg \sin \theta$ and $Mg \cos \theta$, let us replace θ by θ_a , where θ_a is the (constant) angle between the approximate trajectory and the reference axis. If our approximate trajectory is well chosen, we shall have θ nearly equal to θ_a for the period of time we are considering. Also we shall confine attention to small yaws and small malformations of the rocket and so can put

$$\begin{aligned} \cos(\delta - \delta_T) &= 1 \\ \sin(\delta - \delta_T) &= \delta - \delta_T \\ \sin(\delta - \delta_L) &= \delta - \delta_L \\ \sin(\delta - \delta_M) &= \delta - \delta_M \\ \cos \delta &= 1 \\ \sin \delta &= \delta \end{aligned}$$

Our equations simplify to

$$M\dot{v} = T - Mg \sin \theta_a - K_D \rho d^2 v^2 - K_{SP} \rho d^3 v \phi \delta - F_1 \quad (\text{I.5.10})$$

$$Mv\dot{\theta} = T(\delta - \delta_T) - Mg \cos \theta_a + K_L \rho d^2 v^2 (\delta - \delta_L) + K_{SP} \rho d^3 v \phi - F_2 \quad (\text{I.5.11V})$$

$$Mv\dot{\theta} = T(\delta - \delta_T) + K_L \rho d^2 v^2 (\delta - \delta_L) + K_{SP} \rho d^3 v \phi - F_2 \quad (\text{I.5.11H})$$

$$Mk^2\ddot{\phi} = TL - K_M \rho d^3 v^2 (\delta - \delta_M) - K_H \rho d^4 v \phi - \dot{m}\phi(r_r r_e - k^2) - J \quad (\text{I.5.12})$$

One should recall that these equations must be solved in both the vertical and horizontal planes. Thus, in the vertical plane, we have (I.5.10), (I.5.11V), and (I.5.12) to solve, with initial conditions and values of δ_T , δ_L , δ_M , L , F_2 , and J that are peculiar to the vertical plane. Then in the horizontal plane we have (I.5.10), (I.5.11H), and (I.5.12) to solve, with different initial conditions and different values of δ_T , δ_L , δ_M , L , F_2 , and J . Thus one expects to have different values of

δ , ϕ , and θ in the vertical and horizontal planes, though of course the same value of v and s .

As it happens, we can amalgamate the solutions in the two planes by a mathematical trick provided that we can justify neglecting the term $-K_{s\rho d^3}v\phi\delta$ in (I.5.10). This can usually be done. To assess the situation, we write

$$\phi = \frac{d\phi}{ds} \frac{ds}{dt} = v \frac{d\phi}{ds} = v \frac{d\delta}{ds} + v \frac{d\theta}{ds} \quad (\text{I.5.13})$$

As the yawing motion is oscillatory with wave length σ , the analytical expression for δ will be of the form

$$\delta = A \sin \left(\frac{2\pi s}{\sigma} - B \right)$$

We are confining attention to small yaw, say

$$A \leq 0.1$$

To estimate $d\theta/ds$, we refer to (I.5.11V), noting that a similar analysis could be made on the basis of (I.5.11H). We write (I.5.11V) in the form

$$(M - K_{s\rho d^3})v^2 \frac{d\theta}{ds} = T(\delta - \delta_T) - Mg \cos \theta_a \\ + K_{L\rho d^2}v^2(\delta - \delta_L) + K_{s\rho d^3}v^2 \frac{d\delta}{ds} - F_2$$

Typical approximate values for the M8 rocket at sea level are

$$\begin{aligned} d &= 0.375 \text{ ft} \\ M &= 35 \text{ lb} \\ K_{s\rho d^3} &= 0.08 \text{ lb} \\ g &= 32 \text{ ft/sec}^2 \\ \theta_a &= 0 \\ K_{L\rho d^2} &= 0.02 \text{ lb/ft} \\ F_2 &= 0 \\ \sigma &= 200 \text{ ft} \\ K_{D\rho d^2} &= 0.002 \text{ lb/ft} \\ T &= 240,000 \text{ poundals} \\ \delta_T &= 0.005 \text{ rad} \end{aligned}$$

v at end of burning = 1,000 to 1,500 ft/sec, according as the rocket is fired from the ground or from a fast-moving airplane

So

$$v^2 \frac{d\theta}{ds} = 0.03T(\delta - \delta_T) - 32 + 0.007v^2(\delta - \delta_L) + 0.002v^2 \frac{d\delta}{ds}$$

Using this in (I.5.13) and substituting into (I.5.10), we can write

$$M\dot{v} = T[1 - 0.03K_s\rho d^3\delta(\delta - \delta_T)] + 32K_s\rho d^3\delta - Mg \sin \theta_a \\ - \rho d^2v^2 \left[K_D + 1.002K_s d\delta \frac{d\delta}{ds} + 0.0007K_s d\delta(\delta - \delta_L) \right] - F_1$$

As $|\delta|$ and $|\delta - \delta_T|$ are both considerably less than unity, we can neglect $0.03K_s\rho d^3\delta(\delta - \delta_T)$ with respect to unity and

$$0.0007K_s d\delta(\delta - \delta_L)$$

with respect to K_D . We have

$$\delta \frac{d\delta}{ds} = \frac{\pi A^2}{\sigma} \sin \left(\frac{4\pi s}{\sigma} - 2B \right)$$

As $A \leq 0.1$ and $\sigma \cong 200$,

$$\left| \delta \frac{d\delta}{ds} \right| \leq 0.00016$$

So $1.002K_s d\delta(d\delta/ds)$ is less than 1 per cent of K_D and can be neglected.

One should note that the three terms that we have neglected so far are all oscillatory, whereas the correlative terms that dominated them were not oscillatory. Thus the cumulative effects of the neglected terms over several wave lengths of yaw would be even more insignificant. We thus feel assured that these terms will be negligible for a wide variety of rockets, and not merely for the M8.

We are now reduced to

$$M\dot{v} = T + 2.5\delta - Mg \sin \theta_a - K_D\rho d^2v^2 - F_1$$

During burning, the term T is so large that 2.5δ is utterly insignificant. After burning ceases, $K_D\rho d^2v^2$ is of the order of 2,000 and 2.5δ is again utterly insignificant. Thus we are able to ignore the term 2.5δ at all times.

Similar approximations are valid for other rockets, so that for rockets that are likely to be encountered in the usual run of affairs, one can simplify (I.5.10) to

$$M\dot{v} = T - Mg \sin \theta_a - K_D\rho d^2v^2 - F_1 \quad (\text{I.5.14})$$

To amalgamate (I.5.11V) and (I.5.11H) we introduce complex variables δ , ϕ , and θ whose real parts are the values of δ , ϕ , and θ in the vertical plane, and whose imaginary parts are the values of δ , ϕ , and θ in the horizontal plane. Similarly for δ_T , δ_L , and F_2 . Then if we multiply (I.5.11H) by $j (= \sqrt{-1})$ and add to (I.5.11V), we get

the single equation

$$Mv\dot{\theta} = T(\delta - \delta_r) - Mg \cos \theta_a + K_L \rho d^2 v^2 (\delta - \delta_L) + K_S \rho d^2 v \dot{\phi} - F_2 \quad (\text{I.5.15})$$

where θ , δ , δ_r , δ_L , ϕ , and F_2 are complex numbers and all other quantities are real. Although this looks just like (I.5.11V), it actually contains both (I.5.11V) and (I.5.11H) at once. By taking the real part of both sides, we get (I.5.11V), and by taking the imaginary part of both sides, we get (I.5.11H). However, it will be far more convenient to solve (I.5.15) as a single equation in complex variables, and then, when the answer is obtained, to take the real and imaginary parts of the solution and have the solutions to (I.5.11V) and (I.5.11H), respectively.

We proceed similarly with (I.5.12). This is really two equations, one in the vertical plane with one set of $\dot{\phi}$, L , δ , δ_M , ϕ , and J , and the second in the horizontal plane with a different set of $\dot{\phi}$, L , δ , δ_M , ϕ , and J . If we multiply the second by j and add to the first we get

$$Mk^2 \dot{\phi} = TL - K_M \rho d^2 v^2 (\delta - \delta_M) - K_H \rho d^2 v \dot{\phi} - \dot{m} \phi (r/r_a - k^2) - J \quad (\text{I.5.16})$$

where $\dot{\phi}$, L , δ , δ_M , ϕ , and J are complex numbers and all other quantities are real.

We note that from the two cases of (I.5.5) for the vertical and horizontal planes, we can deduce

$$\delta = \phi - \theta \quad (\text{I.5.17})$$

where δ , ϕ , and θ are now complex variables.

We realize that it is a source of confusion to use the same letters, δ , ϕ , and θ for the complex variables occurring in (I.5.15), (I.5.16), and (I.5.17) that we used earlier for their real and imaginary parts in (I.5.5), (I.5.11), and (I.5.12). However, we believe it less confusing than to increase further our already extensive list of symbols, and we trust that the reader, having been warned, will not let himself be confused.

One further transformation of our equations is desirable, namely, to introduce s as the independent variable instead of t . If Q is any quantity, we have

$$\begin{aligned} \dot{Q} &= \frac{dQ}{ds} \frac{ds}{dt} = v \frac{dQ}{ds} \\ \ddot{Q} &= v \frac{d}{ds} \left(v \frac{dQ}{ds} \right) = v^2 \frac{d^2 Q}{ds^2} + v \frac{dv}{ds} \frac{dQ}{ds} \end{aligned}$$

So (I.5.14), (I.5.15), and (I.5.16) reduce to

$$Mv \frac{dv}{ds} = T - Mg \sin \theta_a - K_D \rho d^2 v^2 - F_1 \quad (\text{I.5.18})$$

$$Mv^2 \frac{d\theta}{ds} = T(\delta - \delta_r) - Mg \cos \theta_a \\ + K_L \rho d^2 v^2 (\delta - \delta_L) + K_S \rho d^2 v^2 \frac{d\phi}{ds} - F_2 \quad (\text{I.5.19})$$

$$Mk^2 v^2 \frac{d^2 \phi}{ds^2} + Mk^2 v \frac{dv}{ds} \frac{d\phi}{ds} = TL - K_M \rho d^2 v^2 (\delta - \delta_M) \\ - K_H \rho d^2 v^2 \frac{d\phi}{ds} - \dot{m} v \frac{d\phi}{ds} (r_i r_e - k^2) - J \quad (\text{I.5.20})$$

We leave \dot{m} in (I.5.20) instead of replacing it by $v \, dm/ds$ because \dot{m} is usually a constant.

We should perhaps clarify certain points in connection with the term

$$-K_S \rho d^2 v \phi \delta \quad (\text{I.5.21})$$

in (I.5.10). If we think about the physical significance of this term a bit, we realize that for (I.5.10) to be correct, one should probably have in (I.5.10) two terms like (I.5.21), one with vertical components of ϕ and δ and the other with horizontal components of ϕ and δ , because if the rocket is yawing in two planes at once, then the forward components of cross-spin force from the two components of yawing motion should be added together. Certainly it makes no sense to claim that (I.5.10) is different in the vertical and horizontal planes, as would have to be the case if only one term like (I.5.21) occurred in (I.5.10).

An alternative method of correcting (I.5.10) is to say that in the term (I.5.21) the variables ϕ and δ refer to the actual geometric sizes of ϕ and δ rather than to any components. This is doubtless equivalent to our first suggestion.

In any case, if (I.5.10) is properly written, it will be independent of whether one is dealing with the vertical or horizontal plane. Thus it is not strictly necessary to neglect the term (or terms) of the type of (I.5.21) from (I.5.10) before introducing a complex δ , ϕ , and θ so as to amalgamate (I.5.11V) and (I.5.11H). Nevertheless, if one wishes to deal only with the complex δ , ϕ , and θ , without reference to their components, it is probably necessary to neglect the term (or terms) of the type of (I.5.21) from (I.5.10). It has been suggested that a proper form of (I.5.21) in terms of the complex δ , ϕ , and θ is $-K_S \rho d^2 v |\phi| |\delta|$. However, this will not do, because this would be negative for all values of ϕ and δ , whereas in case ϕ and δ lie in the same plane and have opposite signs, (I.5.21) should be positive. The best thing is to neglect (I.5.21) whenever possible.

CHAPTER II

MOTION AFTER BURNING

✓**The Three Periods of Motion.**—The motion of a rocket, from the time of firing to the time of impact or of detonation, can be divided into three periods: the launching period, the period of burning after launching, and the period of motion after burning is over. These periods are distinguished by the forces acting on the rocket during each period.

During the launching period, the rocket moves through a tube or trough, is suspended from rails, or in general is under the influence of some device which constrains it to follow a straight path, except for the awkward instant while the rocket is leaving the launcher and is only partly subject to launcher constraints. These matters are discussed in detail in Chap. IV.

After leaving the launcher, the interaction between the rocket and launcher disappears, and the rocket is then subject to the forces discussed in Chap. I. This is the period of burning after launching or, for brevity, the burning period. Occasionally rockets are used for pushing or pulling some device, but as a usual thing the only forces acting on the rocket during the burning period are gravity, jet forces, and aerodynamic forces, so that F_1 , F_2 , and J are zero in (I.5.18), (I.5.19), and (I.5.20). The motion during the burning period is discussed in Chap. III with this understanding.

Eventually there will be a time when all the rocket fuel is consumed and the products of combustion of the fuel are completely discharged. After this time comes the period of motion after burning, during which the rocket usually moves under gravity and aerodynamic forces alone. During this period, the rocket obeys the equations of motion derived in Chap. I, but with all jet effects set equal to zero. The solution of the resulting equations will be discussed in this chapter.

The reader may wonder why we have chosen to explain the three periods of rocket motion in just the reverse order to that in which they occur. The chosen order has certain advantages from the point of view of exposition.

The division between the burning period and the period after burning is not sharp; instead, the jet forces dwindle away at the end

of burning, since the products of combustion remaining in the rocket when all the fuel is burned need some time to become completely discharged. For simplicity, we shall assume a definite time called the "end of burning," so chosen that we can consider that there is normal jet activity until this time, and none thereafter. The question of choosing the end of burning will be considered in Chap. III, Sec. 10. The phrase "end of burning" will also be used to denote the position of the rocket at the time "end of burning."

It is possible to construct launching systems such that either of the first two periods is absent. On the one hand, there have been launchers of a sufficient length that all the burning is completed within the launcher, so that the second period is absent. The bazooka is an example of this type. On the other hand, the launcher can be so short that the rocket is not constrained during any appreciable part of its motion, so that the first period is absent. These are called "zero-length launchers."

So far as we know, there has been no interest in a system for which the third period is absent.

Dispersion.—A matter that will concern us greatly is the question of the dispersion of a rocket. The word "dispersion" is used in different senses, which should be distinguished. One sense is the notion of "ammunition dispersion." Suppose one clamps a rifle in a vise, so that it stays exactly in the same position for successive firings. If one then fires a group of rounds of ammunition from this rifle at a fixed target, it will be seen that the rounds do not all strike the target at the same place but are clustered about some center of impact in an irregular pattern. Similarly, rounds striking the ground from a gun at a fixed elevation do not all strike the ground at the same place but are scattered on the ground, both along the direction from the gun to the target and perpendicular to that direction.

It is not surprising that the rounds do not all strike in the same place. The point at which a projectile strikes depends upon all the forces that have acted upon the projectile since the initiation of the firing operation, for instance, the forces exerted by the propellant, by the gun or launching device, by the air, and by the weight of the projectile. None of these quantities can be reproduced exactly. The propellant varies slightly in composition and temperature; a gun has slight irregularities; there are air currents, and shifts in air density and in air forces due to variations of projectile shape; and different rounds have different weights. All these factors, except air, can be more or less controlled in manufacture, but there is a limit to the precision that can be demanded, particularly in quantity production.

From the point of view of the user of ammunition, a fairly rough statistical analysis of ammunition dispersion suffices. For rockets, this statistical analysis follows the same lines that are used for familiar types of ammunition (see Reference 5, Chap. XI and Reference 6, Chaps. 14 and 15) and we do not consider it here. Military requirements will usually dictate that the round shall hit not too far from a predictable "point of aim." The question of aiming the round where it should be aimed can properly be left to the military. However, the designer and manufacturer of rockets have the responsibility for achieving the necessary degree of uniformity of the rounds. To do this they must know the effect on the trajectory of the rocket caused by each structural feature of the rocket or launcher. Moreover, this knowledge must be quantitative, in the sense that they must be able to compute how much a deviation from the structural norm will produce a deviation from the norm in the trajectory. We shall be much concerned with this type of question.

To proceed, we need first to establish the notion of a standard trajectory, namely, that trajectory which a "standard" rocket would follow. Then we consider deviations from this standard trajectory due to various factors. Thus we get away from the statistical notion of dispersion of a group of rounds, the ammunition dispersion, to the distinct but related idea of the dispersion of a single round. A usual measure for such a dispersion is the angle between the actual point of impact of the round and the point of impact of a standard round, this angle being measured from the point of firing. This angle is nearly independent of the range. For mathematical convenience, other measures of dispersion related to this angle may be introduced on occasion.

At the present stage of development, the dispersion of rockets is usually greater than that of rifled guns. A dispersion of 0.001 rad is considered reasonably good for a gun, whereas a dispersion of 0.005 rad is considered quite good for a rocket. For a rocket, dispersion arises from three different sources: events that occur at launching, events during burning after launching, and events after burning. For rockets, most of the dispersion arises during the burning period after launching. This is predicted theoretically and is confirmed by experience. For instance, the bazooka rocket completes its burning before leaving the launcher, and its dispersion is comparable with that of projectiles fired from guns, namely, of the order of 0.001 rad, whereas the best dispersion obtained so far for rockets that burn after leaving the launcher is of the order of 0.004 rad.

It is not always desirable that the dispersion of ammunition should

be kept as low as is consistent with large-scale manufacture. A shotgun shell furnishes a good example of a type of ammunition that is purposely constructed so as to have a high dispersion. Nevertheless, for present military uses, the dispersions of rockets should be small enough so that from the mathematical point of view the dispersion is a differential variation from the standard trajectory. Hence the dispersions arising throughout the three phases of flight—launching, burning, and after burning—can be computed separately and then added algebraically to obtain the net resultant dispersion. However, in this case we must add not the true but the latent dispersions from each period. To illustrate the distinction between the true and latent dispersion, consider the launching period. As the rocket is controlled by the launcher until the end of the launching period, it must necessarily travel along the standard trajectory until the end of launching, unless we have a malformed launcher, which is uncommon. Nevertheless, in coming off the end of the launcher, the rocket is often given a sidewise yaw, for instance, if the launcher is undergoing an acceleration. In such a case, we have a rocket in the right position and going in the right direction but pointed in the wrong direction. Thus it has no actual dispersion—yet. However, the jet is now pointed in the wrong direction, since the rocket is pointed wrong, and the jet is therefore going to force the rocket from the standard trajectory and cause a dispersion to occur. A properly chosen estimate of the final dispersion to be expected from this cause alone is the latent dispersion at the end of launching.

In the mathematical treatment of this and subsequent chapters, the combining of the dispersions from the three different periods of flight will be made quite explicit.

In order to compute the motion of the rocket after burning, it is necessary to know its circumstances at the end of burning. That is, we must know the position and orientation of the rocket and how rapidly these are changing. Mathematically, this means that we must know the value of each of the various independent coordinates necessary to describe the position and orientation of the rocket and the derivative of each coordinate at the end of burning. In Chap. III, we shall tell how to compute the necessary quantities. Throughout the rest of this chapter we shall assume these quantities known and shall be concerned solely with the motion after burning. We shall derive formulas for the dispersion after burning caused by the three aerodynamic forces, drag, lift, and cross-spin force. Of these, the lift contributes the major portion of the dispersion, so that the formulas that we shall give in Sec. 7 for dispersion due to lift can be considered

as approximate formulas for the total dispersion that arises after burning.

1. The Vacuum Trajectory

The complexity of the equations of motion of a rocket, even in the absence of jet forces, is such that these equations will probably never be solved in closed form. We proceed instead to find approximate solutions that are close enough to the exact solution to satisfy our purposes.

The simplest solution is in the case of the vacuum trajectory. To obtain this solution, we neglect all the forces except the weight of the rocket. This solution is well known; the form of the trajectory is a parabola lying in the vertical plane containing the velocity of the rocket at the end of burning. We assume that this solution is known to the reader.

For projectile velocities of only a few hundred feet per second and for massive projectiles, the vacuum approximation is fairly good. At higher velocities the results are rather poor. For example, if the M8 rocket that we are using as our example has a burnt velocity of 1,000 ft/sec at an angle of 45° with the horizontal, the vacuum approximation gives a range of 31,000 ft. A more accurate solution gives a range of 16,400 ft.

The reason for the poor approximation given by the vacuum trajectory is not difficult to see. At 1,000 ft/sec the drag force on an M8 rocket is about 70 lb, whereas the weight of this rocket is only about 35 lb. Therefore we are definitely not justified in neglecting the aerodynamic forces in comparison with gravity.

These remarks are intended to apply to firing at or near sea level. At great altitudes, where the air density is much less, the vacuum trajectory may give a very good approximation. Even at high altitudes, the aerodynamic forces can produce a cumulative effect over a very long range.

2. Definition of Dispersion

The approximation that we now consider is called the "particle approximation," and the trajectory that it furnishes is called the "idealized or particle trajectory." To obtain it, we replace the rocket by a mass particle having the same mass, velocity, direction of travel, and position as the rocket has at the end of burning. This particle is subject to no aerodynamic forces other than gravity and an air drag that is the same function of velocity as is the drag of the rocket with zero angle of yaw.

The problem of computing the idealized trajectory has been studied very extensively, and discussions are given in References 1, 5, 6, 7, and 8. The problem can be solved as accurately as our knowledge of the drag allows.

Like the vacuum trajectory, the idealized trajectory lies in the vertical plane containing the velocity at the end of burning. It is shorter than the vacuum trajectory; as a result of drag, the velocity decreases below that which the particle would have in a vacuum. For a particle fired with an upward component of initial velocity, the descending branch of the idealized trajectory is steeper than the ascending branch.

In the rest of this chapter, we shall assume that the idealized or particle trajectory is known; that is, all the coordinates of the particle are known as functions of time or of each other. We shall distinguish coordinates of the particle from coordinates of the rocket by attaching a subscript i (for idealized) to the coordinates of the particle.

Two supposedly identical rockets, fired under supposedly identical launching conditions, will usually have different idealized trajectories. The reason for this is that, despite all possible care, the two rockets will differ somewhat and will be launched under slightly different conditions. As a result, they will reach the end of burning with slightly differing masses, velocities, directions of travel, and positions. As these are the conditions that determine the idealized trajectories, the two rockets will have different idealized trajectories.

The standard rocket will have a certain mass, velocity, direction of travel, and position at the end of burning. The idealized trajectory based on this set of standard conditions will be called the "standard" trajectory after burning. It is almost, but not quite, the trajectory that the standard rocket would actually follow after burning, so that it might seem slightly misleading to call it the standard trajectory. Nevertheless, it is properly named, since it is used as the standard from which dispersions are computed.

We are now in a position to define with complete precision the latent dispersion at the end of burning. At the end of burning, the usual rocket will not obey standard conditions, so that its idealized trajectory after burning will not be the standard trajectory after burning. The latent dispersion of the rocket at the end of burning is defined to be the dispersion that it would have if it should follow its idealized trajectory exactly.

As a rocket seldom follows its idealized trajectory exactly, it will acquire additional dispersion after burning, namely, the dispersion due to its deviation from its idealized trajectory. The total dispersion

is then the algebraic sum of the latent dispersion and the additional dispersion acquired after burning.

Method of Computing Latent Dispersion.—This chapter is concerned with the dispersion acquired after burning. However before passing on to that, we wish to say a bit about the computation of the latent dispersion at the end of burning. In Chap. III we shall learn how to compute the mass, velocity, direction of travel, and position of a rocket at the end of burning. Thus we may assume that values of these quantities will be available for the standard rocket and for any specific rocket that may be considered. Accordingly, idealized trajectories can be computed for the standard rocket and the specific rocket, and the latent dispersion determined thereby. However, this is laborious and is seldom done. Instead, there is an approximate method in common use which is very quick and which is sufficiently accurate for most purposes, since a really accurate value of the dispersion is seldom required.

As a general thing, any specific rocket will have practically the same mass, velocity, and position at the end of burning as the standard rocket, so that the principal cause of the latent dispersion is the difference in direction of travel. Thus the idealized trajectories for the specific and standard rockets have the same initial conditions except that they start off in slightly different directions. There is a principle of ballistics, known as the principle of the "rigidity of the trajectory" (see Reference 5, page 462 and Reference 6, page 15), which says that in such case the two idealized trajectories are essentially the same shape, so that either can be got by rotating the other through the angle that separates them. Therefore the angular separation of the points of impact of the two trajectories, as viewed from the point of firing, will be the difference in direction at the beginning of the two trajectories. This angular separation of the points of impact is a usual measure of dispersion.

As θ determines the direction of travel of a rocket, the above discussion boils down to the very simple rule that the latent dispersion at the end of burning for a specific rocket is just the difference between the values of θ for the specific rocket and for the standard rocket at the end of burning. One of the quantities that we learn to compute in Chap. III is the value of θ at the end of burning, and so the computation of the latent dispersion at the end of burning is very straightforward.

Computation of Dispersion after Burning.—We now return to the business of this chapter, namely, the discussion of the additional dispersion acquired after burning. Hereafter, throughout the present

chapter the word "dispersion," if not especially modified, will refer only to the additional dispersion acquired after burning.

As we said earlier, the cause of this dispersion is the deviation of the rocket from its idealized trajectory. To set up a precise measure of this dispersion, we consider the point on the actual trajectory that is at a distance s from the end of burning, measured along the actual trajectory, and the point on the idealized trajectory that is also at a distance s from the end of burning measured along the idealized trajectory. We define dispersion as the distance between these two points, divided by the arc length s . For small values of s , the dispersion would be just the angle in radians between the rocket and the particle, as measured by an aiming circle located at the end of burning, if the trajectory were a straight line. Actually, because of curvature of the trajectory, the dispersion will be somewhat different from an aiming circle reading, by an amount which it is difficult to give in a general formula, but it would generally be possible to find the aiming circle reading from the dispersion and the shape of the particle trajectory.

In other words, the dispersion is, loosely, a measure of the angle between the actual and particle trajectories; precisely, it is what the angle would be if both trajectories were straight or nearly so.

The definition of dispersion can be seen from Fig. II.2.1. The length of each trajectory as shown is s ; point O represents the end of burning. Thus the dispersion is η/s , which is approximately the angle between the curves, despite their considerable curvature.

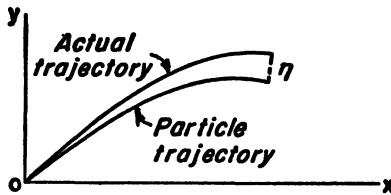

FIG. II.2.1.—An instance of the separation, η , between the actual trajectory and the particle trajectory.

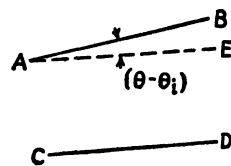

FIG. II.2.2.—Magnified portion of Fig. II.2.1.

For purposes of calculation we use an expression for dispersion which we now derive. Figure II.2.2 shows a section of Fig. II.2.1 greatly enlarged. AB represents a short portion of the actual trajectory of length ds , making an angle θ with the reference axis. CD represents a section of the particle trajectory, also of length ds , making an angle θ_i with the reference axis, while AE represents CD displaced but kept parallel to itself. BE is the change $d\eta$ that occurs in η in the distance ds . Since the angle between AB and AE is $(\theta - \theta_i)$,

we see that $d\eta = (\theta - \theta_i) ds$. Hence, the dispersion is given by

$$\frac{\eta}{s} = \frac{1}{s} \int_0^s (\theta - \theta_i) ds \quad (\text{II.2.1})$$

Thus η/s is just the mean value of $\theta - \theta_i$ taken with respect to arc length of the trajectory. In other words, the dispersion η/s is the average difference in direction between the actual and particle trajectories, which agrees with our basic conception of the dispersion as being in some sense the angle between the actual and idealized trajectories.

3. Sources of Dispersion

The sources of dispersion arise from those aerodynamic terms in the equations of motion which we neglected in computing the particle trajectory, namely, all aerodynamic terms except the air drag at zero yaw. Insofar as the motion of the center of gravity of the rocket is concerned, the aerodynamic forces act in two ways to produce dispersion. First, there are the lift and cross-spin forces which have components perpendicular to the trajectory and hence cause the trajectory to be shifted from the particle trajectory. Second, there is the term that gives the increase in drag with angle of yaw. The rocket drag is greater than the particle drag if the rocket is yawed, so that the rocket loses more velocity, has a greater time of flight to the same trajectory length, and hence has a greater gravity drop. Thus drag tends to shift the actual trajectory *below* the particle trajectory, whereas the lift and cross-spin forces shift it in any direction.

For a stable and well-constructed rocket, the dispersion that arises after burning is small. For instance, consider the extra drag due to yaw, which causes the rocket to fall short of the idealized trajectory. This extra drag varies as the square of yaw [see (I.2.6)]. For the small yaws encountered with well-constructed rockets, the square of the yaw is small and the yaw drag is correspondingly small.

For the lift and cross-spin forces, the picture is not so simple, and we present the discussion in stages. For a first approximation to the actual picture, let us consider a rocket moving in a straight line and yawing about that line in a symmetric fashion. The yawing is a damped oscillation, as will be shown later. The lift is proportional to the yaw [see (I.2.2)]. Thus the lift acts first in one direction and then in the other, and the cumulative effect is much less than if the lift acted always in the same direction. Similar remarks apply to the cross-spin force.

Actually, the usual rocket is not completely symmetric. For instance, it is seldom that δ_M equals zero [see (I.2.4*)]. Thus the rocket will seldom oscillate about a position of zero yaw, since it will tend to oscillate about a position where the yaw equals δ_M , with the result that the lift will act in one direction more than in the other, and the cumulative effect will be much increased. Fortunately, δ_M is usually small, so that this effect does not cause large dispersions.

Finally there are the complications caused by the fact that the rocket does not travel in a straight line. This gives rise to a yaw of repose, and the rocket tends to oscillate about the yaw of repose rather than a position of zero yaw. This results in the lift and cross-spin force both acting on one side more than the other, with consequent increase in the cumulative effect. The yaw of repose will be treated fully in the mathematical sections that follow, but we pause to elucidate the principle involved.

The Yaw of Repose.—We consider the simplified case of a rocket moving in a circle at a constant speed. In particular, imagine a long arm rotating in a horizontal plane about one of its ends and bearing at the outer end a vertical spindle, on which a rocket is freely supported at the center of gravity of the rocket, as in Fig. II.3.1.

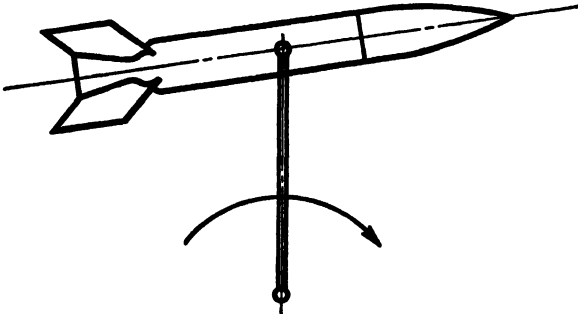

FIG. II.3.1.—Yaw of repose for a rocket pivoted on the end of a rotating arm.

If the arm rotates with constant angular velocity ω , the rocket will eventually assume an equilibrium position with respect to the arm. Then it too will be rotating with angular velocity ω . Thus, by (I.2.5), the rocket is subject to the damping moment $-K_H \rho d^4 v \omega$. Since the rocket is in equilibrium, the damping moment must be canceled by the restoring moment, and so the damping and restoring moments must be numerically equal and opposite in sign. By (I.2.4), the restoring moment is $-K_M \rho d^2 v^2 \sin \delta$. Consequently, we conclude that

$$\sin \delta = \frac{-K_H d \omega}{K_M v}$$

If R is the length of the arm, then $v = -R\omega$ (since ω is negative), so that

$$\sin \delta = \frac{K_H d}{K_M R} \quad (\text{II.3.1})$$

This angle, at which the rocket travels without motion relative to the arm, is called the "yaw of repose."

For the yaw of repose, the aerodynamic couples are balanced but the aerodynamic forces are not. The lift tends to move the rocket farther out on the arm and the cross-spin force tends to move it closer in. In general the lift will be the greater of the two, so that there is a net outward force. In the case of a rocket in flight, the situation is more complicated, since both velocity and curvature of path are variable. Nevertheless, it will be shown that there is a yaw of repose at each point of the trajectory, varying slowly from point to point. The corresponding outward force, due to the lift being greater than the cross-spin force, is a factor in causing dispersion. For this factor also, the net dispersion is not great.

Reduction of Dispersion by Means of a Slow Spin.—As noted above, the asymmetry of the rocket, which makes δ_M different from zero, causes the rocket to yaw more to one side than the other, with a consequent accumulation of dispersion. If, however, the rocket is spinning about its longitudinal axis, the asymmetry will be turning and will not always act in the same direction. Thus the accumulation of dispersion in any given direction will be much reduced. We shall show that a spin even as slow as one rotation in every 2,000 ft of travel can make a significant decrease in dispersion for any range as great as 2,000 ft.

The yaw of repose is determined by the trajectory and not by the orientation of the rocket, so that it is unaffected by the spin.

In imparting a spin to a rocket to reduce dispersion, one may encounter the resonance effect. As noted earlier, the yaw tends to oscillate with a period of σ , the wave length of yaw. If the rocket happens to spin at the rate of one rotation per wave length of yaw, the disturbing effect of the asymmetries of the rocket will operate at the natural frequency of the yaw oscillation and will build up and maintain a yaw. This effect is called "resonance," by analogy with the effect whereby a taut string subjected to a sound of its natural frequency will begin to vibrate and will maintain the vibration as long as the sound persists. We shall see that the yaw caused by resonance is not great.

We remark in passing that bent fins are common, because of care-

less handling. A bent fin will cause a value of δ_M different from zero and hence will tend to cause a dispersion. However, the bent fin will also usually induce a slow spin. This will help diminish the dispersion, which is probably one reason why rocket dispersion is no greater than it is. Nonetheless, one should try to avoid bent fins.

4. An Expression for the Yaw

From the discussion of the preceding section, we see that the first step necessary in finding the dispersion is to find an expression for the angle of yaw. We do this in the present section for a rocket that is spinning slowly about its longitudinal axis. Explicitly, let the rocket be spinning at the rate of Γ rad/ft. Then the asymmetry that gives rise to δ_L and δ_M will rotate at a rate Γ . Thus the maximum effect of δ_L and δ_M will be applied in an ever-changing direction. To handle this mathematically we recall that in (I.5.19) and (I.5.20) the equations for the vertical and horizontal components have been combined into a single equation by the use of complex numbers. Thus we are treating δ_M and δ_L as complex numbers, and so the fact of rotation can be very easily expressed by writing

$$\delta_M = \Delta_M \exp(j\Gamma s) \quad (\text{II.4.1})$$

$$\delta_L = \Delta_L \exp(j\Gamma s) \quad (\text{II.4.2})$$

where Δ_M and Δ_L are the values of δ_M and δ_L at $s = 0$ and $\exp(j\Gamma s)$ is used to denote $e^{j\Gamma s}$.

Define

$$k_D = \frac{K_D}{M} \quad (\text{II.4.3})$$

$$k_L = \frac{K_L}{M} \quad (\text{II.4.4})$$

$$k_S = \frac{K_S}{M} \quad (\text{II.4.5})$$

$$k_M = \frac{K_M}{Mk^2} \quad (\text{II.4.6})$$

$$k_H = \frac{K_H}{Mk^2} \quad (\text{II.4.7})$$

$$B = \frac{1}{2} \left(k_H \rho d^4 + k_L \rho d^2 - k_D \rho d^2 - \frac{g \sin \theta_a}{v^2} \right) \quad (\text{II.4.8})$$

$$A = \frac{k_M \rho d^2 \Delta_M + j\Gamma k_L \rho d^2 \Delta_L}{k_M \rho d^2 + 2j\Gamma - \Gamma^2} \quad (\text{II.4.9})$$

$$\delta_R = \frac{k_H dg \cos \theta_a}{k_M v^2} \quad (\text{II.4.10})$$

We shall show that an expression for the yaw is

$$\delta = \delta_R + A \exp(j\Gamma s) + \exp(-Bs) \left[A_1 \exp\left(\frac{2\pi j s}{\sigma}\right) + A_2 \exp\left(-\frac{2\pi j s}{\sigma}\right) \right] \quad (\text{II.4.11})$$

where A_1 and A_2 are constants of integration and are to be determined by the boundary conditions, that is, the conditions at the end of burning. A determination of A_1 and A_2 is given in (II.4.22) and (II.4.23), and the notation involved therein is explained just before these two formulas.

One should recall that to get the vertical and horizontal components of δ , one should take the real and imaginary parts of (II.4.11).

In (II.4.11), the term δ_R is the yaw of repose, the term $A \exp(j\Gamma s)$ gives the effect of asymmetry and spin, and the remaining term represents a damped oscillation of wave length σ .

We shall show that $v^2/(g \cos \theta_a)$ is the average radius of curvature of the trajectory, so that by (II.4.6) and (II.4.7) we can see that the definition of δ_R agrees with the formula (II.3.1) for the yaw of repose.

If $\Gamma = 0$, then the term $A \exp(j\Gamma s)$ reduces to δ_M . So, for a rocket with no spin, the yaw is a damped oscillation about the value $\delta_R + \delta_M$. If there is spin, then the term $A \exp(j\Gamma s)$ is an oscillation with the same frequency as the spin, and this oscillation is superposed upon the damped oscillation of wave length σ . In case the rocket spins once every wave length of yaw, one would expect some sort of resonance phenomenon to occur, and it does. In such case $\Gamma = 2\pi/\sigma$, so that, by (I.2.13) and (II.4.6),

$$\Gamma = \sqrt{\frac{K_M \rho d^3}{M k^2}} = \sqrt{k_M \rho d^3}$$

with the result that the denominator of A becomes very small and A becomes large. For other rates of spin, A is quite small. Some notion of the behavior of A is given by Fig. II.6.1, in which it has been assumed that $\Delta_L = 1.5\Delta_M$, and then $|A/\Delta_M|^2$ has been plotted for the M8 rocket against γ , which is defined to be $\sigma\Gamma/2\pi$. Thus $\gamma = 1$ corresponds to resonance.

Numerical Considerations with Respect to Yaw.—Let us pause for a few numerical considerations, based on the M8 rocket. Typical values are $v = 1,000$ ft/sec, $M = 35$ lb, and $Mk^2 = 20$ lb ft². So, from the values given in Sec. 2 of Chap. I, we compute

$$\begin{aligned}
 k_D &= 0.0058 \text{ lb}^{-1} \\
 k_L &= 0.067 \text{ lb}^{-1} \\
 k_S &= 0.58 \text{ lb}^{-1} \\
 k_M &= 0.316 \text{ lb}^{-1}\text{ft}^{-2} \\
 k_H &= 1.58 \text{ lb}^{-1}\text{ft}^{-2}
 \end{aligned}$$

The value of d is 0.375 ft. At sea level, a typical value for ρ is 0.073 lb/ft³. The value of B is seen to be quite insensitive to the value of θ_a , and we get

$$B = 0.0015 \text{ ft}^{-1}$$

By (I.2.13), $\sigma = 180$ ft, but for the convenience of having a round figure it is usual to use $\sigma = 200$ ft. We get

$$\delta_R = 0.000060 \cos \theta_a \text{ rad}$$

Thus for the M8 rocket, the yaw of repose is so nearly zero as to be essentially negligible.

If we may take the values of δ_M and δ_L from Sec. 2 of Chap. I as typical, then from Fig. II.6.1 we see that even when resonance occurs, the maximum value of $A \exp(j\Gamma s)$ will be of the order of 0.1 rad, and for most cases it will be much less. Thus in the usual case, when resonance does not occur, the important term in the yaw is liable to be the rightmost term of (II.4.11), namely, the term giving the damped oscillation of wave length σ . Even this dies off fairly quickly, since, from the value of B that we computed, we see that the amplitude decreases about 25 per cent each wave length of yaw.

We are assuming that the yaw is not large. Specifically, we are assuming that the maximum value of δ from all causes is of the order of 0.1.

Derivation of the Expression for the Yaw.—We proceed now to the derivation of (II.4.11). Let us set all jet terms and extraneous forces equal to zero in (I.5.18), (I.5.19), and (I.5.20). We then divide the first two of these by M and the third by Mk^2 . There results

$$v \frac{dv}{ds} = -g \sin \theta_a - k_D \rho d^2 v^2 \quad (\text{II.4.12})$$

$$v^2 \frac{d\theta}{ds} = -g \cos \theta_a + k_L \rho d^2 v^2 (\delta - \delta_L) + k_S \rho d^3 v^2 \frac{d\phi}{ds} \quad (\text{II.4.13})$$

$$v^2 \frac{d^2\phi}{ds^2} + v \frac{dv}{ds} \frac{d\phi}{ds} = -k_M \rho d^3 v^2 (\delta - \delta_M) - k_H \rho d^4 v^2 \frac{d\phi}{ds} \quad (\text{II.4.14})$$

Since $\phi = \theta + \delta$ [see (I.5.17)], we can write (II.4.13) in the form

$$v^2 \frac{d\theta}{ds} (1 - k_S \rho d^3) = -g \cos \theta_a + k_L \rho d^2 v^2 (\delta - \delta_L) + k_S \rho d^3 v^2 \frac{d\delta}{ds}$$

For the M8 at sea level,

$$k_{sp}d^3 = 0.0022$$

and so is negligible compared to unity. Thus, we reduce (II.4.13) to

$$v^2 \frac{d\theta}{ds} = -g \cos \theta_a + k_L \rho d^2 v^2 (\delta - \delta_L) + k_{sp} \rho d^3 v^2 \frac{d\delta}{ds} \quad (\text{II.4.15})$$

We pause to derive a bit of information from this equation. We recall from calculus that $d\theta/ds$ is the curvature of the trajectory, the curvature being defined as the reciprocal of the radius of curvature. On the right side of (II.4.15) we have one term, $-g \cos \theta_a$, which changes very slowly, whereas the other two terms, because of the presence of δ and its derivative, oscillate with a period of σ . So our curvature consists of a steady term with an oscillatory term superimposed. In other words, the trajectory has a fairly constant over-all curvature but in detail it has small wiggles of wave length σ . In this connection, see Fig. I.3.3, where the small wiggles are very apparent and the over-all curvature can be detected by comparison with the straight line AB .

To find the over-all curvature, we omit the oscillatory terms from (II.4.15). Therefore, the over-all curvature is given by

$$\frac{d\theta}{ds} = -\frac{g \cos \theta_a}{v^2}$$

In other words, the average radius of curvature is $v^2/g \cos \theta_a$.

From (II.4.15) we can get a numerical estimate for $d\theta/ds$ for the M8 rocket. The first term on the right is of the order of 30 ft/sec². If we have a small yaw, so that $|\delta - \delta_L| \leq 0.1$, then the second term is at most of the order of 70 ft/sec². Since δ oscillates with a period of σ , the maximum value of $d\delta/ds$ is $2\pi/\sigma$ times the maximum value of δ . Thus the third term on the right of (II.4.15) is at most of the order of 7 ft/sec². So the maximum value of $d\theta/ds$ is of the order of 0.0001 ft⁻¹.

In a similar fashion, we find from (II.4.12) that the maximum value of dv/ds is of the order of 0.1 sec⁻¹.

We now divide (II.4.15) by v and differentiate both sides with respect to s . Most of the terms resulting from this differentiation can be neglected. Let us consider one case in detail. After dividing through by v , one of the terms on the right will be

$$k_L \rho d^2 v (\delta - \delta_L) \quad (\text{II.4.16})$$

When we differentiate this term, we get the sum of four terms,

$$\frac{dk_L}{dv} \frac{dv}{ds} \rho d^2v (\delta - \delta_L) \quad (\text{II.4.17})$$

$$k_L \frac{d\rho}{dy} \frac{dy}{ds} d^2v (\delta - \delta_L) \quad (\text{II.4.18})$$

$$k_L \rho d^2 \frac{dv}{ds} (\delta - \delta_L) \quad (\text{II.4.19})$$

and

$$k_L \rho d^2v \left(\frac{d\delta}{ds} - \frac{d\delta_L}{ds} \right) \quad (\text{II.4.20})$$

Since the maximum value of $d\delta/ds$ is $2\pi/\sigma$ times the maximum value of δ , we may consider (II.4.20) as being of the order of 3 per cent of (II.4.16). However, since $|dv/ds| \leq 0.1$ and $v = 1,000$, we see that (II.4.19) is only 0.01 per cent of (II.4.16). So we shall neglect (II.4.19) by comparison with (II.4.20).

In trying to estimate (II.4.17), we are under the difficulty of knowing practically nothing about dk_L/dv . However, we shall assume that it does not behave any worse than dk_D/dv , about which something is known. Taking the Gâvre drag function for shells as typical (see Reference 1, pages 110 to 117, and Reference 8, pages 34 to 39), it appears that even at its worst place (near the speed of sound), dk_D/dv is at most about 0.5 per cent of k_D and, for most values of v , dk_D/dv is very small. We shall assume the same for dk_L/dv . Then (II.4.17) is at most 0.05 per cent of (II.4.16) and is usually much smaller. So we can neglect (II.4.17) by comparison with (II.4.20).

To estimate (II.4.18), we note that a good approximation for ρ is

$$\rho = \rho_0 \exp(-ay)$$

where $\rho_0 = 0.073$ lb/ft³, $a = 0.0000316$ ft⁻¹, and y is the distance above sea level in feet. Then

$$\frac{d\rho}{dy} = -a\rho = -0.0000316\rho$$

As s is the arc length along the trajectory, dy/ds cannot be greater than unity. So (II.4.18) is at most 0.00316 per cent of (II.4.16) and can certainly be neglected by comparison with (II.4.20).

Thus we decide that, with adequate accuracy, we can take the single term (II.4.20) to be the derivative of (II.4.16). Arguing similarly for the other terms of (II.4.15), we conclude that if we divide

(II.4.15) by v and differentiate, we get

$$v \frac{d^2\theta}{ds^2} + \frac{dv}{ds} \frac{d\theta}{ds} = k_L \rho d^2 v \left(\frac{d\delta}{ds} - \frac{d\delta_L}{ds} \right) + k_S \rho d^3 v \frac{d^2\delta}{ds^2}$$

We multiply this by v and subtract from (II.4.14). The resulting equation has derivatives of both θ and ϕ on the left side, but these can be combined into derivatives of δ alone by use of the relation $\delta = \phi - \theta$. There still remains a term on the right involving $d\phi/ds$. In this we put

$$\frac{d\phi}{ds} = \frac{d\theta}{ds} + \frac{d\delta}{ds}$$

and substitute for $d\theta/ds$ from (II.4.15). The result is

$$\begin{aligned} v^2 \frac{d^2\delta}{ds^2} (1 + k_S \rho d^3) + v \frac{d\delta}{ds} \left(\frac{dv}{ds} + k_H \rho d^4 v + k_L \rho d^2 v + k_H k_S \rho^2 d^2 v \right) \\ + v^2 \delta (k_M \rho d^3 + k_H k_L \rho^2 d^6) = k_M \rho d^2 v^2 \delta_M + k_H \rho d^4 g \cos \theta_a \\ + k_H k_L \rho^2 d^6 v^2 \delta_L + k_L \rho d^2 v^2 \frac{d\delta_L}{ds} \end{aligned}$$

Using numerical estimates based on the M8 rocket, it appears that in this equation we can neglect the terms involving either k_S or the product $k_H k_L$. We substitute for dv/ds from (II.4.12) and divide the equation through by v^2 . Remembering the definition of B from (II.4.8), the result can be written

$$\frac{d^2\delta}{ds^2} + 2B \frac{d\delta}{ds} + k_M \rho d^3 \delta = k_M \rho d^3 \delta_M + k_L \rho d^2 \frac{d\delta_L}{ds} + \frac{k_H \rho d^4 g \cos \theta_a}{v^2}$$

In order to get this in solvable form, we substitute for δ_M and δ_L from (II.4.1) and (II.4.2) and make use of the fact that B^2 is negligible compared to $k_M \rho d^3$. Thus we have finally the equation

$$\begin{aligned} \frac{d^2\delta}{ds^2} + 2B \frac{d\delta}{ds} + (k_M \rho d^3 + B^2) \delta = (k_M \rho d^3 \Delta_M \\ + j\Gamma k_L \rho d^2 \Delta_L) \exp(j\Gamma s) + \frac{k_H \rho d^4 g \cos \theta_a}{v^2} \quad (\text{II.4.21}) \end{aligned}$$

If all terms occurring in this equation were constant except s , δ , and the derivatives of δ , then (II.4.11) would be an exact solution (except for neglecting B^2 by comparison with $k_M \rho d^3$ in δ_R and A), as can be readily seen by substituting (II.4.11) into (II.4.21) and recalling that

$$\frac{2\pi}{\sigma} = \sqrt{k_M \rho d^3}$$

To determine the constants of integration A_1 and A_2 , we must decide on an origin for s . For the present chapter, we take the origin of s to be the end of burning. The boundary conditions will be the values of δ and $d\delta/ds$ at the end of burning. These values will essentially be furnished by the results of Chap. III. To be precise, the equations of Chap. III furnish us with values for δ_b and δ'_b . The subscript b denotes the end of burning, and the prime denotes differentiation with respect to the dimensionless arc length

$$S = \frac{2\pi s}{\sigma} = \sqrt{k_M \rho d^3} s$$

So δ_b is the value of δ at the end of burning and δ'_b is $\sigma/2\pi$ times the value of $d\delta/ds$ at the end of burning. With this meaning for δ_b and δ'_b , and remembering that the end of burning corresponds to $s = 0$, we determine the values of A_1 and A_2 to be

$$A_1 = \frac{1}{2} \left[-j\delta'_b + \left(1 - \frac{jB\sigma}{2\pi} \right) (\delta_b - A - \delta_R) - \frac{\sigma\Gamma A}{2\pi} \right] \quad (\text{II.4.22})$$

$$A_2 = \frac{1}{2} \left[j\delta'_b + \left(1 + \frac{jB\sigma}{2\pi} \right) (\delta_b - A - \delta_R) + \frac{\sigma\Gamma A}{2\pi} \right] \quad (\text{II.4.23})$$

More Accurate Expressions for the Yaw.—In saying that (II.4.11) is a solution of (II.4.21), we are assuming that δ_R , A , Γ , B , and σ are all constant. Actually, none of these is constant, so that when we substitute (II.4.11) into (II.4.21), many terms, involving first and second derivatives of δ_R , A , Γ , B , and σ , will fail to cancel each other. We can improve this situation somewhat by replacing Bs and $2\pi js/\sigma$ in (II.4.11) by $\int_0^s B ds$ and $2\pi j \int_0^s ds/\sigma$. If the resulting form of (II.4.11) is substituted into (II.4.21), there will be fewer terms that will not cancel. In particular, there will be no terms involving second derivatives of B or σ .

An analogous improvement will result from replacing $j\Gamma s$ by $j \int_0^s \Gamma ds$ in (II.4.1), (II.4.2), (II.4.11), and (II.4.21).

By slightly modifying the definitions of δ_R and A , still other non-canceling terms may be disposed of. For instance, let us take δ_R as a solution of the differential equation

$$\frac{d^2\delta_R}{ds^2} + 2B \frac{d\delta_R}{ds} + (k_M \rho d^3 + B^2)\delta_R = \frac{k_M \rho d^4 g \cos \theta_a}{v^2} \quad (\text{II.4.24})$$

This differential equation is arrived at as follows: Substitute (II.4.11)

into (II.4.21). Then collect all terms involving δ_R or its derivatives from the left side, and require that they exactly cancel the term $k_H \rho d^4 g \cos \theta_a / v^2$ on the right. The result is just (II.4.24).

Since δ_R is a small term in (II.4.11), it is not necessary to take great pains to find an accurate solution of (II.4.24). The approximate solution, (II.4.10), obtained by neglecting derivatives of δ_R in (II.4.24), is accurate enough for most purposes. Should greater accuracy be desired, one can compute approximate values of $d^2 \delta_R / ds^2$ and $d \delta_R / ds$ from (II.4.10) and substitute them into (II.4.24), which then would give a more accurate value for δ_R .

By substituting (II.4.11) into (II.4.21), collecting all terms involving A or its derivatives, and requiring that they exactly cancel the term $(k_M \rho d^2 \Delta_M + j \Gamma k_L \rho d^2 \Delta_L) \exp(j \Gamma s)$, one can get a differential equation for A , more complicated than (II.4.24), but similar. (II.4.9) is a first approximation to the solution. From (II.4.9), more accurate solutions can be obtained in the same way that was used for (II.4.24).

These various suggestions for improving the accuracy of (II.4.11) will be of little practical value until information is available about the variation of K_D , K_L , K_M , K_S , and K_H with velocity. Nevertheless, these considerations indicate that the general form of (II.4.11) is right and that the relative magnitudes of the terms are about right. As the phase of the oscillation is more sensitive to small errors, one probably cannot trust (II.4.11) to give the phase very accurately after a few wave lengths of yaw.

5. Solution for the Dispersion

Having obtained a satisfactory solution for δ , we now proceed to use this in solving for the dispersion. In finding the dispersion, we are not interested in v and θ directly but only in the differences between these and the v and θ for the idealized trajectory. We write

$$\Delta v^2 = v^2 - v_i^2$$

and $\Delta \theta = \theta - \theta_i$, recalling that a subscript i refers to the idealized trajectory.

By (I.2.6) and (II.4.3),

$$k_D = \frac{K_{D_0}(1 + K_{D_\delta} \delta^2)}{M}$$

To avoid a difficult notation, we shall write

$$k_D = k_d + k_\delta \delta^2 \tag{II.5.1}$$

throughout the rest of this chapter. For the M8 rocket

$$k_d = 0.0058 \text{ lb}^{-1}$$

$$k_s = 0.125 \text{ lb}^{-1}$$

One should note that in using (II.5.1) the value of δ^2 is the square of the actual physical yaw. With the complex value that we are using for δ , the actual physical yaw is $|\delta|$. So (II.5.1) should preferably be written

$$k_D = k_d + k_s|\delta^2|$$

The equations that are solved in computing the idealized trajectory are

$$v_i \frac{dv_i}{ds} = -g \sin \theta_i - k_d \rho_i d^2 v_i^2 \quad (\text{II.5.2})$$

$$v_i^2 \frac{d\theta_i}{ds} = -g \cos \theta_i \quad (\text{II.5.3})$$

We subtract these from (II.4.12) and (II.4.15). There results

$$\frac{d}{ds} (\Delta v^2) = 2g \sin \theta_i - 2g \sin \theta_a + 2k_d d^2 (\rho_i v_i^2 - \rho v^2) - 2k_s \rho d^2 v^2 |\delta^2|$$

$$\frac{d}{ds} (\Delta \theta) = \frac{g \cos \theta_i}{v_i^2} - \frac{g \cos \theta_a}{v^2} + k_L \rho d^2 (\delta - \delta_L) + k_s \rho d^3 \frac{d\delta}{ds}$$

One can justify replacing ρ by ρ_i in these equations, since ρ is such a slowly varying function. Also, since θ and θ_i are nearly equal, it would seem that θ_i would be a very appropriate value to use for θ_a . So we simplify to get

$$\frac{d}{ds} (\Delta v^2) = -2k_s \rho_i d^2 v_i^2 |\delta^2| - 2(k_d + k_s |\delta^2|) \rho_i d^2 \Delta v^2 \quad (\text{II.5.4})$$

$$\frac{d}{ds} (\Delta \theta) = \frac{g \cos \theta_i}{v_i^4} \Delta v^2 + k_L \rho_i d^2 (\delta - \delta_L) + k_s \rho_i d^3 \frac{d\delta}{ds} \quad (\text{II.5.5})$$

As the ideal trajectory is supposed known, it is presumed that the values of θ_i , ρ_i , v_i , k_d , k_s , k_L , and k_s are known as functions of s . δ_L is given by (II.4.2), and δ and $d\delta/ds$ by (II.4.11). Thus (II.5.4) and (II.5.5) are two simultaneous differential equations for Δv^2 and $\Delta \theta$, subject to the boundary conditions $\Delta v^2 = \Delta \theta = 0$ at $s = 0$.

If we temporarily put

$$P = 2(k_d + k_s |\delta^2|) \rho_i d^2$$

$$Q = 2k_s \rho_i d^2 v_i^2 |\delta^2|$$

then (II.5.4) takes the form

$$\frac{d}{ds} (\Delta v^2) + P(\Delta v^2) = -Q$$

The solution of this is readily verified to be

$$\Delta v^2 = - \exp \left(- \int_0^s P ds \right) \int_0^s \left[Q \exp \left(\int_0^s P ds \right) \right] ds \quad (\text{II.5.6})$$

This gives Δv^2 as a function of s , so that we can now integrate both sides of (II.5.5) and get

$$\Delta \theta = \int_0^s \left[\frac{g \cos \theta_i}{v_i^4} \Delta v^2 + k_{L\rho_i} d^2 (\delta - \delta_L) + k_{s\rho_i} d^3 \frac{d\delta}{ds} \right] ds \quad (\text{II.5.7})$$

By (II.2.1), the dispersion is given by

$$\frac{1}{s} \int_0^s \Delta \theta ds \quad (\text{II.5.8})$$

and so, by use of (II.5.7), the dispersion can be computed.

6. An Estimate of the Dispersion Due to Yaw Drag

We propose to show that the contribution of the yaw drag to dispersion is quite small. To this end, we make some fairly rough estimates of just how large it can be.

We turn first to (II.5.6) and make various approximations. Let us first assume that

$$v_i^2 \exp \left(\int_0^s P ds \right) \quad (\text{II.6.1})$$

is constant. This has a certain plausibility. Because of air drag, we expect v_i^2 to be decreasing, whereas $\exp \left(\int_0^s P ds \right)$ is surely increasing. In fact, we can be more specific. If we neglect $g \sin \theta_i$ in (II.5.2), we get

$$\frac{d}{ds} (v_i^2) = -2k_{a\rho_i} d^2 v_i^2$$

The solution of this is

$$v_i^2 = v_b^2 \exp \left(- \int_0^s 2k_{a\rho_i} d^2 ds \right)$$

where v_b is the value of v_i at $s = 0$. As we are confining attention to small δ , there will not be a great difference between $2k_{a\rho_i} d^2$ and P . Therefore, we are reasonably justified in assuming that (II.6.1) is constant.

If it is constant, we can take it outside the integral sign in (II.5.6), with the result

$$\Delta v^2 = - v_b^2 \int_0^s 2k_{s\rho_i} d^2 |\delta^2| ds$$

Having taken this step, we might as well assume that $k_{\delta\rho}d^2$ is constant, and so we get

$$\frac{\Delta v^2}{v_i^2} = -2k_{\delta\rho}d^2 \int_0^s |\delta^2| ds \quad (\text{II.6.2})$$

We refer back to (II.4.11) and write

$$|\delta| \leq |\delta_R| + |A| + \exp(-Bs) \left| A_1 \exp\left(\frac{2\pi js}{\sigma}\right) + A_2 \exp\left(-\frac{2\pi js}{\sigma}\right) \right|$$

As we are confining attention to small yaws, we assume that the maximum value of $\left| A_1 \exp\left(\frac{2\pi js}{\sigma}\right) + A_2 \exp\left(-\frac{2\pi js}{\sigma}\right) \right|$ is 0.1. Also we recall that δ_R is very small, and neglect it. So

$$|\delta| \leq |A| + 0.1 \exp(-Bs)$$

Thus

$$|\delta^2| \leq |A^2| + 0.2 \exp(-Bs)|A| + 0.01 \exp(-2Bs)$$

So, by (II.6.2),

$$\begin{aligned} \left| \frac{\Delta v^2}{v_i^2} \right| &\leq 2k_{\delta\rho}d^2 \int_0^s [|A^2| + 0.2 \exp(-Bs)|A| + 0.01 \exp(-2Bs)] ds \\ &\leq 2k_{\delta\rho}d^2 \left\{ |A^2|s + \frac{|A|}{5B} [1 - \exp(-Bs)] \right. \\ &\quad \left. + \frac{1}{200B} [1 - \exp(-2Bs)] \right\} \\ &\leq 2k_{\delta\rho}d^2 \left(|A^2|s + \frac{|A|}{5B} + \frac{1}{200B} \right) \end{aligned}$$

We put this into the first term on the right-hand side of (II.5.7) and assume that $(g \cos \theta)/v_i^2$ is constant. So

$$\left| \int_0^s \left(\frac{g \cos \theta_i}{v_i^2} \Delta v^2 \right) ds \right| \leq \frac{g \cos \theta_i k_{\delta\rho} d^2}{v_i^2} \left(|A^2|s^2 + \frac{2|A|}{5B} s + \frac{s}{100B} \right) \quad (\text{II.6.3})$$

To find the dispersion due to yaw drag, we compute that part of (II.5.8) which is due to the first term on the right-hand side of (II.5.7). So by (II.6.3) an upper bound for the dispersion due to yaw drag is

$$\frac{g \cos \theta_i k_{\delta\rho} d^2}{v_i^2} \left(\frac{1}{3} |A^2|s^2 + \frac{|A|}{5B} s + \frac{s}{200B} \right) \quad (\text{II.6.4})$$

Let us make some numerical estimates of this for the M8 rocket. If we assume $\Delta_L = 1.5\Delta_M$, then A is a multiple of Δ_M . In Fig. II.6.1,

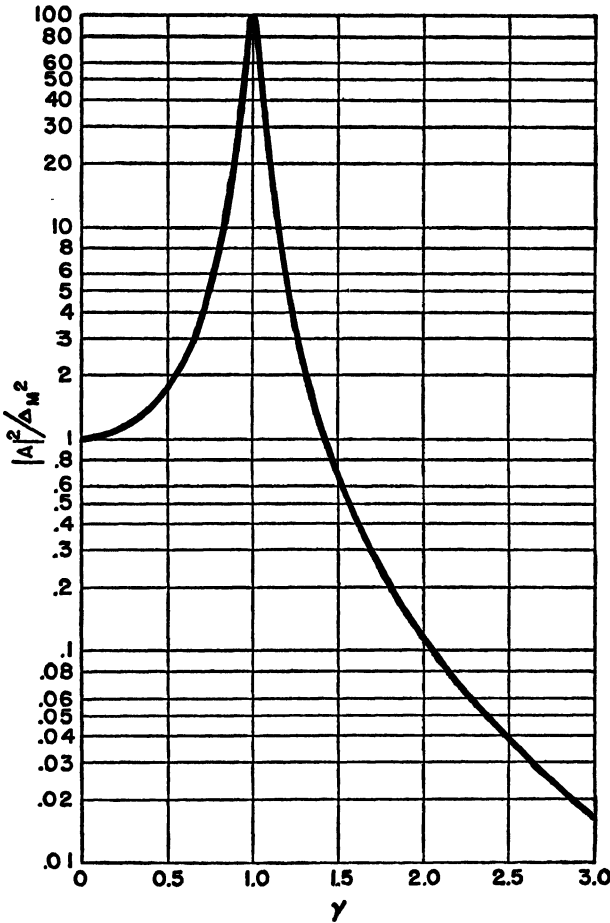

FIG. II.6.1.—Amplitude of yaw as a function of spin for an M8 rocket.

- $|A|$ = Amplitude of yaw.
- Δ_M = Fin malalignment angle.
- γ = Number of revolutions per wave length of yaw.

we have plotted $|A/\Delta_M|^2$ for the M8 rocket against γ , which is defined to be $\sigma\Gamma/2\pi$, so that $\gamma = 1$ corresponds to resonance. At sea level

$$k_s \rho_s d^2 = 0.0013 \text{ ft}^{-1}$$

We shall take $(g \cos \theta_i)/v_i^2$ to be of the order of 3×10^{-5} . We recall that

$$B = 0.0015 \text{ ft}^{-1}$$

Then (II.6.4) reduces to

$$1.3 \times 10^{-8}|A^2|s^2 + 6 \times 10^{-6}|A|s + 1.5 \times 10^{-7}s \quad (\text{II.6.5})$$

The maximum value of s that is likely to occur in actual use for the M8 rocket is not over 5,000 ft. Putting this maximum s into (II.6.5), we get the maximum dispersion due to yaw drag to be

$$0.3|A^2| + 0.03|A| + 0.0007$$

If we take $|\Delta_M| = 0.01$ as typical, we see from Fig. II.6.1 that even at resonance the dispersion due to yaw drag is at most 0.007 rad. If we look back over our estimates, particularly the estimates for $|\delta|$, we see that this final figure is probably an overestimate by a factor of 2 or 3. Also it combines all the worst possibilities, such as very long range (for practical operations), maximum permissible yaw ($= 0.1$), and a resonance effect due to the rocket rotating exactly once every wave length of yaw. Thus under normal operating conditions the dispersion due to yaw drag should run well under 0.001 rad. By comparison with a dispersion of 0.01 rad or more, which is common for an M8 rocket, we may ignore the dispersion due to yaw drag, since it seems pointless to know the dispersion to within better than 10 per cent.

7. Dispersion Due to Lift

This dispersion arises from the second term on the right in (II.5.7). In case there is no spin the dispersion due to lift can be quite large. However, even a slow spin, as little as one rotation in 2,000 ft, will keep the dispersion due to lift within reasonable bounds.

In the second term on the right of (II.5.7), we assume that $k_{L\rho_i}d^2$ is constant and substitute δ from (II.4.11) and δ_L from (II.4.2). Performing the integration gives

$$k_{L\rho_i}d^2 \left\{ \delta_{RS} + \frac{A - \Delta_L}{j\Gamma} [\exp(j\Gamma s) - 1] \right. \\ \left. + \frac{A_1\sigma}{2\pi j - B\sigma} \left[\exp\left(\frac{2\pi js}{\sigma} - Bs\right) - 1 \right] \right. \\ \left. - \frac{A_2\sigma}{2\pi j + B\sigma} \left[\exp\left(-\frac{2\pi js}{\sigma} - Bs\right) - 1 \right] \right\}$$

as the contribution to $\Delta\theta$ due to the lift. Substituting this into (II.5.8) gives

$$\begin{aligned}
 k_{L\rho}d^2 \left\{ \frac{1}{2} \delta_{RS} + \frac{A - \Delta_L}{j\Gamma} \left[\frac{\exp(j\Gamma s) - 1}{j\Gamma s} - 1 \right] \right. \\
 + \frac{A_1\sigma^2}{2\pi j - B\sigma} \left[\frac{\exp\left(\frac{2\pi js}{\sigma} - B_s\right) - 1}{(2\pi j - B\sigma)s} - \frac{1}{\sigma} \right] \\
 \left. + \frac{A_2\sigma^2}{2\pi j + B\sigma} \left[\frac{\exp\left(-\frac{2\pi js}{\sigma} - B_s\right) - 1}{(2\pi j + B\sigma)s} + \frac{1}{\sigma} \right] \right\} \quad (\text{II.7.1})
 \end{aligned}$$

as the contribution to the dispersion due to the lift. We consider $\Gamma \neq 0$ for the moment and reserve consideration of the case $\Gamma = 0$ until later. For small s , all terms are small. For larger s , say $s = 2\sigma$ or $s = 3\sigma$, one will simply have to compute (II.7.1) the hard way, by substituting in values, taking the values of A_1 and A_2 from (II.4.22) and (II.4.23). However, for large s , the various terms with s in the denominator become of little consequence by comparison with the other terms in the square brackets, and we can simplify (II.7.1) to

$$k_{L\rho}d^2 \left(\frac{1}{2} \delta_{RS} - \frac{A - \Delta_L}{j\Gamma} - \frac{A_1\sigma}{2\pi j - B\sigma} + \frac{A_2\sigma}{2\pi j + B\sigma} \right)$$

Substituting into this for A_1 and A_2 and noting that $(B\sigma)^2$ is negligible with respect to $4\pi^2$, we get finally

$$k_{L\rho}d^2 \left(\frac{1}{2} \delta_{RS} - \frac{A - \Delta_L}{j\Gamma} + \frac{\sigma\delta'_b}{2\pi} + \frac{B\sigma^2(\delta_b - A - \delta_R)}{2\pi^2} - \frac{j\sigma^2\Gamma A}{4\pi^2} \right) \quad (\text{II.7.2})$$

For the M8 rocket, we can omit the term $\frac{1}{2}\delta_{RS}$, since we are not likely to encounter a value of s greater than 5,000. Also, since $\delta_b - A - \delta_R$ is not likely to be greater than 0.2, we can omit the term containing it. Thus we simplify (II.7.2) to

$$k_{L\rho}d^2 \left(\frac{\sigma\delta'_b}{2\pi} - \frac{A - \Delta_L}{j\Gamma} - \frac{j\sigma^2\Gamma A}{4\pi^2} \right) \quad (\text{II.7.3})$$

Since δ'_b is $\sigma/2\pi$ times the value of $d\delta/ds$ at $s = 0$, we may expect δ'_b to be as large as 0.1 on occasion. In such a case $k_{L\rho}d^2(\sigma\delta'_b/2\pi)$ would be of the order of 0.002 rad, which is possibly not negligible but certainly is not great.

The term involving $A - \Delta_L$ will cause trouble if Γ is too small. However, Γ can be remarkably small without causing trouble. For instance, suppose our rocket is rotating once every 2,000 ft. Then $\Gamma = 2\pi/2,000$. For such a small value of Γ , A is essentially equal to

Δ_M . So

$$k_{L\rho_s}d^2 \frac{A - \Delta_L}{j\Gamma} = \frac{0.2}{j} (\Delta_M - \Delta_L)$$

As Δ_M and Δ_L are of the order of 0.01, this term will not be unreasonably large. If Γ is ten times as large, we have resonance, so that A is ten times as large (see Fig. II.6.1) and the term is still appreciable. However, for larger Γ the value of A decreases rapidly and we may ignore the term.

The term $k_{L\rho_s}d^2 (j\sigma^2\Gamma A/4\pi^2)$ is appreciable only for Γ near the resonance value. There $\Gamma = 2\pi/\sigma$, and A is of the order of 0.1 and therefore

$$\left| k_{L\rho_s}d^2 \frac{j\sigma^2\Gamma A}{4\pi^2} \right| = 0.0022$$

From the above casual analysis, it would appear that one gets appreciable dispersion at resonance, and hence that resonance is to be avoided. A more careful analysis will dispel this notion. Write (II.7.3) in the form

$$k_{L\rho_s}d^2 \left[\frac{\sigma\delta_b'}{2\pi} + \frac{\Delta_L}{j\Gamma} + \frac{\sigma^2jA}{4\pi^2\Gamma} \left(\frac{4\pi^2}{\sigma^2} - \Gamma^2 \right) \right]$$

In this form we see that A , which is large at resonance, is multiplied by $(4\pi^2/\sigma^2) - \Gamma^2$, which is zero at resonance. Hence the total dispersion will not be particularly increased if resonance occurs.

Now consider the case of no spin, namely, $\Gamma = 0$. If we check through the derivations of (II.7.2) and (II.7.3), we shall find that the term $(A - \Delta_L)/j\Gamma$ will be replaced by $\frac{1}{2}(\delta_M - \delta_L)s$. This would cause an unpleasantly large dispersion even for s no greater than 2,000 ft. Hence it would seem that a rocket should be so constructed as to fly with a slow spin. Even as little spin as one rotation in 2,000 ft is efficacious in reducing dispersion. Small irregularities would perhaps be sufficient to cause this much spin; however, it is well not to leave the matter to chance.

8. Dispersion Due to the Cross-spin Force

This is apparently negligible. It would come from the final term in (II.5.7). If we assume $k_{s\rho_s}d^3$ to be constant in this, we can integrate and get $k_{s\rho_s}d^3(\delta - \delta_b)$ as the contribution to $\Delta\theta$ due to the cross-spin force. We put this into (II.5.8) and get

$$k_{s\rho_s}d^3 \left(\frac{1}{s} \int_0^s \delta ds - \delta_b \right)$$

as the contribution to the dispersion due to the cross-spin force. By the methods of the preceding section, we can perform the integration and estimate the value of the answer. Upon doing so, it is found to be negligible.

We thus conclude that only the lift terms are of value in computing the dispersion, and hence that the formulas (II.7.1), (II.7.2), and (II.7.3) for computing the dispersion due to lift will actually serve as formulas for the dispersion.

9. Application to a Different Projectile

Throughout this chapter, whenever we have used the characteristics of a specific projectile by way of illustration, that projectile was always the M8 rocket. The reason for using the M8 is that more extensive data exist for it than for any other rocket of which we know.

One might question whether the results of this chapter, which are often based on the characteristics of the M8 rocket, are valid for rockets in general. To answer this question, we shall consider a quite different rocket, making estimates when measurements are not available. This rocket, which we refer to as rocket *A*, has a diameter of 0.375 ft, a weight of 100 lb, and a moment of inertia of 286 lb ft². The various aerodynamic coefficients for this rocket that have been measured are

$$\begin{array}{lll} K_L = 8.41 & k_L = 0.0841 & \\ K_M = 38.6 & k_M = 0.135 & \sigma = 280 \text{ ft} \\ K_D = 0.284 & k_d = 0.00284 & k_s = 0.0815. \end{array}$$

From measurements made with and without fins, to which we apply the reasoning used in deriving (I.2.11) and (I.2.12), treating fins and body separately, we estimate

$$\begin{array}{ll} K_H = 382 & k_H = 1.335 \\ K_S = 49.2 & k_S = 0.492 \end{array}$$

These values are sufficiently near those of the M8 so that none of the conclusions of this chapter are invalidated. In general, we believe that these conclusions will hold for a large class of artillery rockets.

10. Reconsideration of Certain Assumptions

Now that we have some means of estimating the size of $\Delta\theta$, it would be well to check certain assumptions we made, which depended essentially on the value of $\Delta\theta$ being small.

When we chose θ_i as an appropriate value for θ_a in the course of deriving (II.5.4) and (II.5.5), we were assuming that θ_i was quite near θ . To see this, note that θ_a first appeared in the equations back in Chap. I, as an approximate value for θ . If we eliminate this additional approximation, then we see that in our derivation of (II.5.4) and (II.5.5) there would actually have been a θ where we had θ_a , and so we were actually claiming that in those terms one could replace θ by θ_i . Had we not made such a replacement, there would have been an additional term on the right of each of (II.5.4) and (II.5.5), namely, a term involving $\Delta\theta$.

In Secs. 6, 7, and 8, we were concerned with estimating the dispersion and did not pause to estimate $\Delta\theta$. However, had we done so, we would have found that $\Delta\theta$ is so small that the terms involving $\Delta\theta$ that should occur in (II.5.4) and (II.5.5) can be neglected.

To the uninitiated, this may sound like a bit of lifting by your bootstraps. To wit, we neglect some terms in $\Delta\theta$ in order to get an expression for $\Delta\theta$ and then use this expression for $\Delta\theta$ to justify neglecting the terms in $\Delta\theta$. However, it is a justifiable procedure. The critical test of our expression for $\Delta\theta$ is whether it satisfies the differential equations, the correct ones with no terms omitted. It does indeed satisfy these differential equations approximately, because if we substitute it back into the differential equations, it renders negligible those terms which we neglected, and it satisfies the remaining terms, which it was chosen to satisfy.

While on this subject, we can now justify our original assumption that it is possible to choose a θ_a which is constant or slowly varying, and which is nearly equal to θ for an appreciable portion of the trajectory. At the time we introduced the concept of an approximate trajectory, we spoke glibly of the over-all curvature being small and the wiggles in the trajectory being small, but we did not prove that such was actually the case. However, we now see that a very suitable choice for θ_a would indeed be θ_i , as suggested once before. θ_i is very near θ , since $\Delta\theta$ is small. Also, θ_i changes very slowly, as indicated by (II.5.3), and so can be treated as being nearly constant.

We also made an approximation without mentioning it when we divided (II.4.15) by v , differentiated with respect to s , and then neglected various terms. One term that was neglected involved the derivative $d\theta_a/ds$. However, this was permissible. Even had we been more accurate and retained θ instead of replacing it by θ_a , the corresponding term involving $d\theta/ds$ could have been shown to be negligible by the same methods used to show that sundry other terms were negligible.

11. A Numerical Example

For the sake of a numerical example, let us arbitrarily assume that at the end of burning

$$\begin{aligned}
 \text{Latent dispersion} &= 0.020 + 0.010j \\
 \delta_b &= 0.080 - 0.060j \\
 \delta'_b &= 0.060 + 0.080j \\
 \Delta_M &= 0.010 \\
 \Delta_L &= 0.015j
 \end{aligned}$$

We shall compute the dispersion for a range of 2,000 ft for four cases:

$$\begin{aligned}
 \text{No spin} &\quad \Gamma = 0 \\
 \text{Slow spin} &\quad \Gamma = 0.0035 \\
 \text{Resonance spin} &\quad \Gamma = \sqrt{k_M \rho d^3} = 0.0348 \\
 \text{Faster spin} &\quad \Gamma = 0.0500
 \end{aligned}$$

The corresponding values of A are

$$\begin{aligned}
 &0.010 \\
 &0.010 \\
 &-0.116j \\
 &-0.009 - 0.001j
 \end{aligned}$$

By use of (II.7.3) the corresponding dispersions are

$$\begin{aligned}
 &-0.006 + 0.012j \\
 &0.004 + 0.004j \\
 &0.001 + 0.002j \\
 &0.001 + 0.002j
 \end{aligned}$$

A dispersion of $-0.006 + 0.012j$ means that from the point of aim the rocket will appear to be 0.006 rad below and 0.012 rad to the left of the idealized trajectory. As this is at a range of 2,000 ft, the rocket will be 12 ft below and 24 ft to the left of the idealized trajectory.

Adding in the latent dispersion, we find the total dispersion for the four cases to be

$$\begin{aligned}
 &0.014 + 0.022j \\
 &0.024 + 0.014j \\
 &0.021 + 0.012j \\
 &0.021 + 0.012j
 \end{aligned}$$

CHAPTER III

MOTION DURING BURNING

During burning, the rocket obeys the equations of motion derived in Chap. I. In the present chapter, we solve these equations under the assumption that no forces are acting on the rocket except jet forces and aerodynamic forces. In other words, F_1 , F_2 , and J are zero in (I.5.18), (I.5.19), and (I.5.20).

The boundary conditions under which we solve the equations are the conditions at the end of the launching period, which will be given us from the results in Chap. IV. Specifically, we shall require the coordinates of the center of gravity, the components of velocity of the center of gravity, the orientation of the rocket about its center of gravity, and the components of angular velocity of the rocket about its center of gravity, all to be evaluated at the end of launching. To indicate the value of a variable at the end of launching, we attach a subscript p . This notation is probably a carry-over from a time when a launcher was inappropriately called a "projector."

To supply the needs of Chap. II, we must derive expressions for various quantities at the end of burning. Values at this time will be designated by a subscript b .

Rather commonly, a person will be interested only in the dispersion of a rocket. As indicated earlier, the dispersion is a measure of the deviation of the trajectory of the rocket from the trajectory of some standard rocket. In Chap. II, we saw that the quantities needed to compute the dispersion are the basic data of the rocket (such as σ , K_B , d , etc.), the velocity at the end of burning [see (II.4.8) and (II.4.10)], the values of δ_b and δ'_b [see (II.4.22) and (II.4.23)], and the latent dispersion at the end of burning. For an exact determination of the latent dispersion at the end of burning, fairly complete data at the end of burning are needed. These data will be available from the formulas of the present chapter. However, a common approximation to the latent dispersion is the difference between θ_b for the given rocket and for a standard rocket. Hence, for the usual computations of dispersion, the data needed from the present chapter will be merely the values of v_b , δ_b , δ'_b , and θ_b . Accordingly, we give special attention to the means of computing these quantities.

The Standard Rocket.—For a standard rocket, we assume that there is no malformation of the rocket. Thus $\delta_L = \delta_M = \delta_T = L = 0$ for a standard rocket, and the motion is subject to only the “standard” forces, namely, properly aligned jet forces, gravity, and aerodynamic forces on a symmetric rocket. One might suppose that for a standard rocket one would have the launching conditions $\delta_p = \delta_\theta = 0$. This is not necessarily so. While a random or unintentional yaw is bad, there may be cases where a standard yaw is purposely introduced to accomplish certain ends. An instance is the following: Let a forward-firing rocket be installed beneath a wing of a fighter plane. It is desired that the rocket shall be aimed to strike a point 1,000 ft directly in front of the plane. To allow for the gravity drop of the rocket while traveling the 1,000 ft, the rocket must be aimed slightly above the horizontal. If the plane is in horizontal flight when the rocket is fired, the center of gravity of the rocket will be sharing the horizontal motion of the plane, so that $\theta = 0$, whereas ϕ is positive since the rocket is aimed slightly above the horizontal. In this circumstance a small positive yaw will be a standard condition of launching. There are also conditions where a nonzero value of δ_p will be a standard launching condition, but the discussion of these had best be postponed until Chap. IV.

Considerations with Regard to Dispersion during Burning.—For rockets that burn after launching, the dispersion is considerably larger than for the conventional type of projectile. The reason for this is fairly simple. If an ordinary type of projectile develops a yaw, there will be only lift and cross-spin forces tending to push it off its course. Moreover, the effect of these is not very great, as we saw in Chap. II. On the other hand, if a rocket yaws while burning, then the thrust will no longer be pointed in the direction of motion of the center of gravity. Thus there will be a component of thrust tending to push the rocket off its course, in addition to the lift and cross-spin forces. For most rockets the thrust is so great that the sidewise force from an out-of-line thrust far exceeds the sidewise force due to lift or cross spin.

Thus we see that an unintended yaw that occurs during burning will cause a far greater dispersion than a corresponding yaw after burning.

One curious effect should be noted, namely, that the main part of the dispersion arises during the early portion of the burning. This is due to the fact that during the burning the rocket is accelerating from rest or from a relatively low velocity to a much greater velocity. The reader will recall from Chap. I that the sidewise acceleration is given by $v\dot{\theta}$. Consequently, if one has a given sidewise acceleration

at a low velocity, the resulting value of θ will be much greater than if one has the same sidewise acceleration at a high velocity. As it is the change in θ that will determine the latent dispersion at the end of burning (and hence ultimately a large share of the total dispersion), we see that the large values of θ that can occur during the early stages of burning when velocities are low will cause more dispersion than the small values of θ that will occur in the final stages of burning when velocities are high.

The reader will note one implicit assumption in the above analysis, namely, that sidewise accelerations are likely to be the same at all stages of burning. For the usual rocket, the thrust and mass change little during burning, so that one may expect little variation of the forward acceleration, with correspondingly little variation of the sidewise acceleration due to a given yaw. Actually, there tend to be smaller yaws in the later stages of burning [see the remarks after (III.1.55)], with consequently smaller sidewise accelerations in the later stages of burning, which is all the more reason why the major portion of the dispersion arises in the early stages of burning.

A large increase in the thrust or decrease in the mass during burning will weaken the above conclusions, but it is unlikely that a case will occur where the variations in thrust or mass will be proportionally as great as the change in velocity. Accordingly, it may be accepted as generally true that the major portion of the dispersion arises during the early stages of burning.

From this fact it has sometimes been argued that we need not be distressed about our lack of knowledge of the behavior at high velocities of the various aerodynamic coefficients K_D , K_L , K_S , K_M , and K_H . The reasoning is that most of the dispersion arises early in the burning when velocities are low and the coefficients are known and reasonably constant, and so our estimates of dispersion based on the assumption of constant coefficients will be reliable. If the rocket is fired from rest, the reasoning is valid. However, if the rocket is fired forward from a very fast plane, the rocket is already moving quite fast at the beginning of burning, and the reasoning is not trustworthy.

A suggested means of reducing dispersion is to give the rocket a slow spin during burning. The theory behind this is similar to that behind the use of a slow spin to reduce dispersion after burning. Specifically, dispersion arises from some malformation of the rocket that tends to cause a yaw. If the rocket does not spin, this malformation acts in a fixed orientation, and the cumulative effect will be a dispersion in that orientation. However, if the rocket spins, the

malformation acts first in one orientation and then in another, and there is little cumulative effect tending to cause a dispersion in any orientation.

Since the major portion of the dispersion arises early in burning, there must be spinning early in the burning if the spinning is to be effective in reducing dispersion. In fact, spin at the rate of two or more rotations per wave length of yaw during the first wave length of yaw after launching is apparently quite effective in reducing dispersion, even if the spin dies out completely later in the burning.

Because of the large dispersion of rockets and the great efforts to reduce this dispersion, there has been a considerable preoccupation with dispersion. Accordingly, workers have sought simple formulas that would give a sufficiently accurate value of the dispersion for purposes of design or comparison of different rockets. To this end, the dispersion after burning is often ignored, since it is complicated and is seldom a large part of the dispersion. In other words, the latent dispersion at the end of burning is taken as constituting the entire dispersion. The reader will recall that a reasonable approximation or the latent dispersion is the difference between θ , for the given rocket and a standard rocket. Efforts to simplify the formula for this difference have been quite successful, so that there is now known a simple approximation for this difference. In effect then, there is now known a simple approximation for the dispersion of a rocket. This approximation is given early in Sec. 1 of this chapter.

1. The Basic Solution

The so-called "basic" solution is a fairly simple solution, for the case of no spin, which has a fair accuracy. It is obtained by neglecting all but the major effects. It can be used to answer qualitative or roughly quantitative questions with a minimum of computation. Alternatively it can be used as the first step in getting a more accurate solution, and in subsequent sections of this chapter we shall list various correction terms to be added to the basic solution in order to take account of the neglected minor effects. In some cases, these corrections have amounted to as much as 20 per cent of the basic solution. Nonetheless, the basic solution determines the over-all behavior of the more exact solution.

To arrive at the basic solution, we neglect the component of gravity in the direction of the trajectory, the drag, the lift, the cross-spin force, the damping moment, and the jet-damping term, as well as all forces that are neither jet forces nor aerodynamic forces. Then

(I.5.18), (I.5.19), and (I.5.20) simplify to

$$Mv \frac{dv}{ds} = T$$

$$Mv^2 \frac{d\theta}{ds} = T(\delta - \delta_T) - Mg \cos \theta_a$$

$$Mk^2v^2 \frac{d^2\phi}{ds^2} + Mk^2v \frac{dv}{ds} \frac{d\phi}{ds} = TL - K_M \rho d^3v^2(\delta - \delta_M)$$

Dividing the first two by M and the third by Mk^2 , recalling (I.2.13), and putting $G = T/M$, we get

$$v \frac{dv}{ds} = G \quad (\text{III.1.1})$$

$$v^2 \frac{d\theta}{ds} = G\delta - G\delta_T - g \cos \theta_a \quad (\text{III.1.2})$$

$$v^2 \frac{d^2\phi}{ds^2} + v \frac{dv}{ds} \frac{d\phi}{ds} = G \frac{L}{k^2} - \frac{4\pi^2}{\sigma^2} v^2(\delta - \delta_M) \quad (\text{III.1.3})$$

G is the acceleration of the rocket due to the thrust.

We further assume that G , δ_T , θ_a , L/k^2 , σ , and δ_M are constant.

To determine a solution of the three equations, we usually have given the values v_p , θ_p , δ_p , and ϕ_p of v , θ , δ , and ϕ at the end of the launcher. One more condition is needed, namely, the value p of s at the end of the launcher. In other words, we need to choose a constant of integration for s in the equation

$$s = \int v dt$$

which defines s [see (I.5.3)]. Our choice will be such that when we integrate both sides of (III.1.1) the constant of integration will be zero, and we will get

$$v^2 = 2Gs \quad (\text{III.1.4})$$

In other words, we define p by

$$v_p^2 = 2Gp \quad (\text{III.1.5})$$

This often results in a very artificial choice for p , especially in firing from aircraft (see Sec. 5 for further details). The value of p is sometimes called the "effective launcher length," because it is the length a launcher should be so that a rocket starting from rest at the beginning of the launcher would have a velocity v_p at the end of the launcher.

The Formula for θ .—In solving the equations, the greatest interest has attached to the formula for θ , since this can be used to estimate the dispersion, as we explained earlier. We postpone the details of the

solution while we have a preview of the formula for θ . It is

$$\begin{aligned} \theta = & \theta_p + \left(\delta_T + \frac{g \cos \theta_a}{G} \right) G_1 \\ & + \frac{\sigma L}{2\pi k^2} G_2 - \delta_M (G_1 + G_3) \\ & + \delta_v G_3 + \frac{\sigma \phi_p}{2\pi v_p} G_4 \end{aligned} \tag{III.1.6}$$

where $G_1, G_2, G_3,$ and G_4 are functions of s and p . The precise formulas for $G_1, G_2, G_3,$ and G_4 are given in (III.1.48) to (III.1.55),

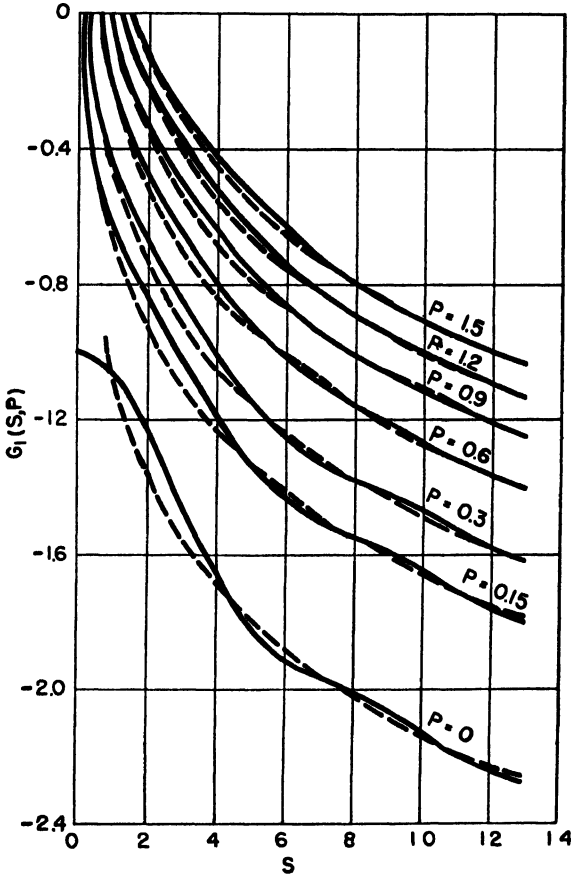

FIG. III.1.1.—The function $G_1(S, P)$. Dashed lines are asymptotic approximations.

inclusive. However, these are rather too complicated to use for simple dispersion considerations, and we propose to note some simpler approximate formulas. These make use of the functions $ir(w), ra^2(w), rr(w),$ and $rj(w)$. These are four of the “rocket” functions defined in Chap.

V, where also are to be found extensive tables of the functions for use in computational work.

Our approximation for G_1 is

$$G_1 = \begin{cases} \frac{1}{2} \left[ir \left(\frac{2\pi p}{\sigma} \right) - ir \left(\frac{2\pi s}{\sigma} \right) \right] & \text{unless } p = 0 \text{ and } s < 0.15\sigma \\ -1 & \text{if } p = 0 \text{ and } s < 0.15\sigma \end{cases} \quad (\text{III.1.7})$$

In Fig. III.1.1, we have illustrated the accuracy of this approximation. The solid lines are the exact values of G_1 , the dashed lines are the values of

$$\frac{1}{2} \left[ir \left(\frac{2\pi p}{\sigma} \right) - ir \left(\frac{2\pi s}{\sigma} \right) \right]$$

and S and P denote $2\pi s/\sigma$ and $2\pi p/\sigma$, respectively. It will be observed that the approximation is nowhere off by more than about 10 per cent.

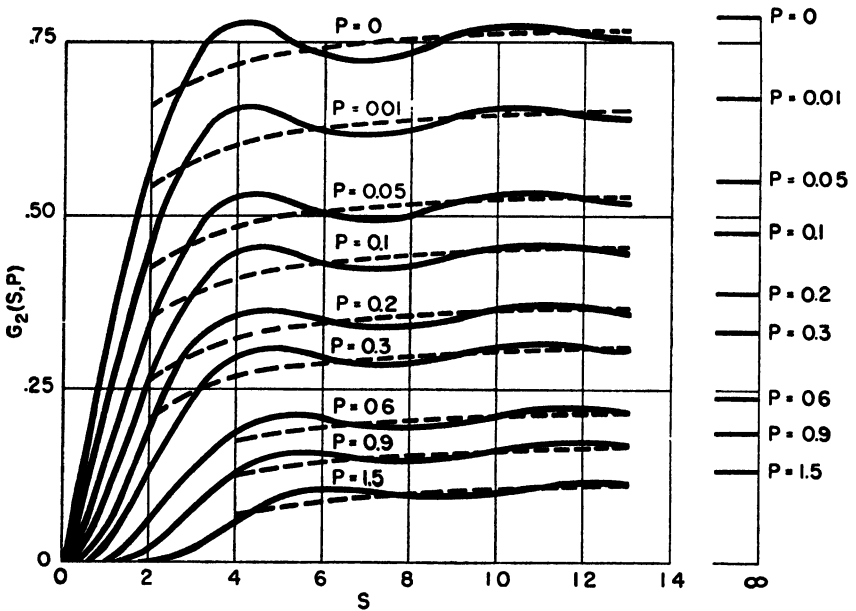

FIG. III.1.2.—The function $G_2(S, P)$. Dashed lines are asymptotic approximations.

Our approximation for G_2 is

$$G_2 = \begin{cases} \frac{2\pi(\sqrt{s} - \sqrt{p})^2}{3\sigma\sqrt{s}} & s - p < \frac{\sigma}{3} \\ \frac{1}{4} ra^2 \left(\frac{2\pi p}{\sigma} \right) - \frac{\sigma}{8\pi s} & s - p \geq \frac{\sigma}{3} \end{cases} \quad (\text{III.1.8})$$

In Fig. III.1.2, we have illustrated the accuracy of this approximation when $s - p \geq \sigma/3$. The solid lines are the exact values of G_2 and the dashed lines are the values of our approximation for the case $s - p \geq \sigma/3$. S and P are as before. The values of our approximation for the case $s - p < \sigma/3$ are not shown. However, except near the critical point $s - p = \sigma/3$, the approximation is fairly good. Near $s - p = \sigma/3$, the approximation may be off by as much as 20 per cent in some cases.

Our approximation for G_3 is

$$G_3 = \begin{cases} 1 - \frac{\sqrt{p}}{\sqrt{s}} & s - p < \frac{\sigma}{10} \\ 1 - \sqrt{\frac{2\pi p}{\sigma}} \operatorname{er}\left(\frac{2\pi p}{\sigma}\right) & s - p \geq \frac{\sigma}{10} \end{cases} \quad \text{(III.1.9)}$$

In Fig. III.1.3, we have illustrated the accuracy of this approximation when $s - p \geq \sigma/10$. The solid lines are the exact values of G_3

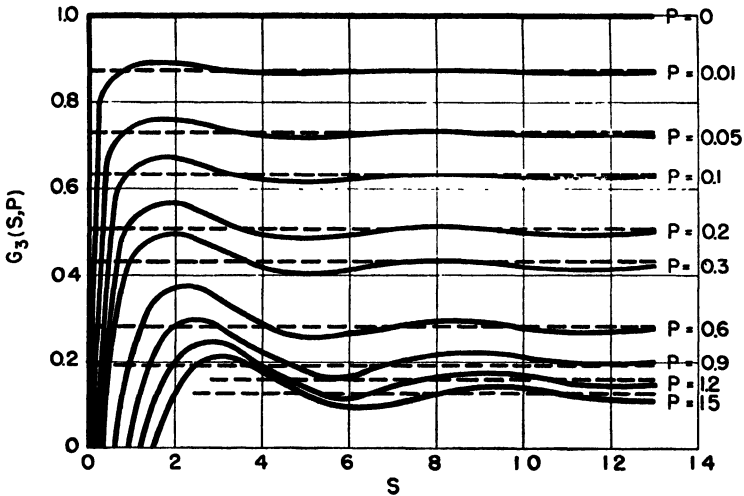

FIG. III.1.3.—The function $G_3(S,P)$. Dashed lines are asymptotic approximations.

and the dashed lines are the values of our approximation for the case $s - p \geq \sigma/10$. S and P are as before. The values of our approximation for the case $s - p < \sigma/10$ are not shown. However, the approximation for $s - p < \sigma/10$ is quite good in that range. The approximation for $s - p \geq \sigma/10$ is rather poor for large values of P and somewhat larger values of S . For instance, it is off nearly 50 per cent at $S = 3, P = 1.5$. However, for large P, G_3 is small, so that the approximation does not differ greatly from G_3 in actual value, although the percentage of discrepancy may be great.

Our approximation for G_4 is

$$G_4 = \begin{cases} \frac{2\pi \sqrt{p}}{\sigma \sqrt{s}} (\sqrt{s} - \sqrt{p})^2 & s - p < \frac{\sigma}{4} \\ \sqrt{\frac{2\pi p}{\sigma}} r_j \left(\frac{2\pi p}{\sigma} \right) & s - p \geq \frac{\sigma}{4} \end{cases} \quad (\text{III.1.})$$

In Fig. III.1.4, we have illustrated the accuracy of this approximation when $s - p \geq \sigma/4$. The solid lines are the exact values G_4/\sqrt{P} and the dashed lines are the corresponding values deri

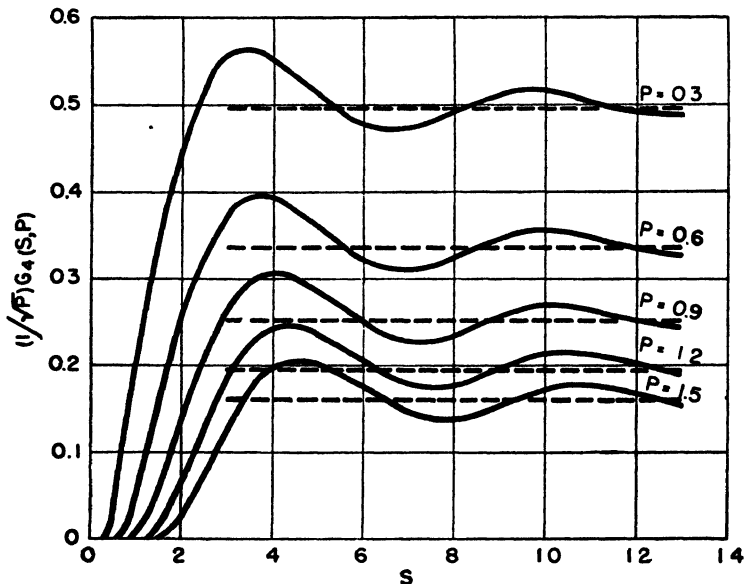

FIG. III.1.4.—The function $G_4(S,P)$, divided by \sqrt{P} . Dashed lines are asympt approximations.

from our approximation for the case $s - p \geq \sigma/4$. S and P are before. The values derived from our approximation for the c $s - p < \sigma/4$ are not shown. However, the approximation $s - p < \sigma/4$ is fairly good in that range, being comparable to approximation for $s - p \geq \sigma/4$ in its range.

In Fig. III.1.5, we show the values of $-(G_1 + G_3)$ to aid the rea in comprehending the general behavior of this combination, which the coefficient of δ_M in the formula for θ . The dashed lines give values of the approximation obtained by combining the rocket fu tion approximations for G_1 and G_3 .

We note one peculiarity of our formula for θ . For most val of p , if we put $s = p$, we get $\theta = \theta_p$, quite appropriately. Not so

$p = 0$. If we put $p = 0$ and then put $s = p$ in (III.1.6) to (III.1.10), inclusive, we get

$$\theta = \theta_p - \left(\delta_T + \frac{g \cos \theta_a}{G} \right) + \delta_p$$

At first thought, this seems quite improper. However, a little cogitation will clear up the matter. Since $p = 0$, we see from (III.1.5) that $v_p = 0$. In other words, the rocket is at rest at the time of launching. For a stationary rocket, θ has no meaning, and consequently δ also

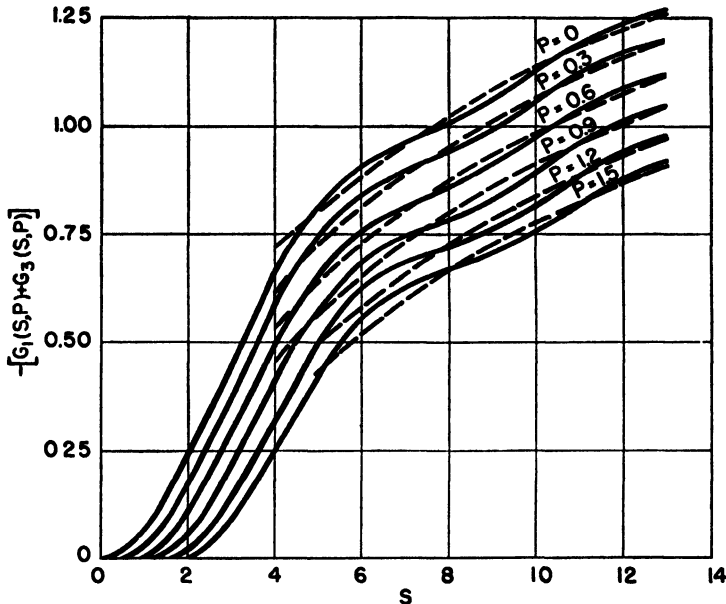

FIG. III.1.5.—The function $-[G_1(S,P) + G_3(S,P)]$. Dashed lines are asymptotic approximations.

has no meaning. In other words, when $p = 0$, neither θ_p nor δ_p have any meaning. Hence it is not surprising that when $s = p$, θ fails to take the value θ_p .

This poses the question, what to do with our formula for θ when $p = 0$ if θ_p and δ_p have no meaning when $p = 0$? Fortunately, the formula for θ takes care of itself very nicely in this crisis. When $p = 0$, $G_3 = 1$ [see (III.1.54), (III.1.50), and (III.1.19)], so that

$$\theta_p + \delta_p G_3 = \theta_p + \delta_p = \phi_p$$

So when $p = 0$, our formula for θ simplifies to

$$\theta = \phi_p + \left(\delta_T + \frac{g \cos \theta_a}{G} \right) G_1 + \frac{\sigma L}{2\pi k^2} G_2 - \delta_M (G_1 + 1) + \frac{\sigma \phi_p}{2\pi v_p} G_4$$

Since ϕ_p is perfectly well defined, this takes care of the indeterminacy of θ_p and δ_p when $p = 0$. However, we still need to consider what happens to the term $(\sigma\phi_p/2\pi v_p)G_4$ when $p = 0$. Since

$$v_p = \sqrt{2Gp}$$

this would appear to involve a zero in the denominator. However, G_4 has a factor \sqrt{p} [see (III.1.10) or (III.1.55), (III.1.51), and (III.1.19)] so that G_4/v_p has a definite limit as p goes to zero.

Accordingly, although the case $p = 0$ requires special attention, it causes no real trouble.

We now use (III.1.6) to (III.1.10) to make some general observations about dispersion. Let θ_s , θ_{ps} , δ_{ps} , ϕ_{ps} , G_s , σ_s , and v_{ps} denote the values of θ , θ_p , δ_p , ϕ_p , G , σ , and v_p for the standard rocket. Then the dispersion is given (roughly) by

$$\begin{aligned} \theta - \theta_s &= \theta_p - \theta_{ps} + \left(\delta_\tau + \frac{g \cos \theta_a}{G} - \frac{g \cos \theta_a}{G_s} \right) G_1 + \frac{\sigma L}{2\pi k^2} G_2 \\ &\quad - \delta_M(G_1 + G_3) + (\delta_p - \delta_{ps})G_3 + \left(\frac{\sigma\phi_p}{2\pi v_p} - \frac{\sigma_s\phi_{ps}}{2\pi v_{ps}} \right) G_4 \quad (\text{III.1.11}) \end{aligned}$$

In discussing this formula, it is convenient to have names for the various terms that occur. We acquaint the reader with the names that are in common use. δ_τ is called the "jet malalignment angle," and the term

$$\left(\delta_\tau + \frac{g \cos \theta_a}{G} - \frac{g \cos \theta_a}{G_s} \right) G_1$$

is called the "jet malalignment angle term" or "gravity drop term." L is called the "jet malalignment distance," and the term involving L is named correspondingly. The quantity δ_M most commonly arises from a bent fin, and so δ_M is called the "fin malalignment angle," with a corresponding name for the term involving it. δ_p and ϕ_p are called the "initial yaw" and "initial angular velocity," and their terms correspondingly.

Commonly, and more briefly, the terms are simply called the δ_τ term, L term, δ_M term, δ_p term and ϕ_p term.

The L term, δ_p term, and ϕ_p term illustrate most vividly the remark that most of the dispersion arises early in the burning period. In at most half a wave length of yaw, G_2 , G_3 , and G_4 have risen to an asymptotic value and change very little more as the burning proceeds. For the δ_τ term and δ_M term, the situation is not quite so obvious. The function $-G_1$ never levels off the way G_2 , G_3 , and G_4 do. However,

it goes up much more slowly for large S than for the region shown in Fig. III.1.1. For large w , $\dot{w}(w)$ goes up as the logarithm [see (V.7.11)]. Consequently, although in Fig. III.1.1 $-G_1$ appears to be going up quite rapidly at $S = 13$, it will get to be only about twice as large by the time S gets up to $13^2 (= 169)$.

Let us make a rough estimate of the comparative sizes of $\delta_T G_1$ and $(\sigma L/2\pi k^2)G_2$. By (I.5.1), $L = r_t \delta_T$. If we put roughly

$$\begin{aligned} r_t &= \frac{1}{3}\mathcal{L} \\ k^2 &= \frac{\mathcal{L}^2}{12} \end{aligned}$$

where \mathcal{L} is the length of the rocket, then

$$\frac{\sigma L}{2\pi k^2} G_2 \cong \frac{3\sigma}{\pi \mathcal{L}} \delta_T G_2$$

For the M8 rocket, $\sigma = 200$ and $\mathcal{L} = 3$ are typical, so that

$$\frac{\sigma L}{2\pi k^2} G_2 \cong 64 \delta_T G_2$$

For the burning distance of the M8, G_2 is probably greater than $-\frac{1}{4}G_1$. Hence the contribution to the dispersion of the M8 caused by δ_T is less than one-tenth that caused by L . Accordingly, we may ignore δ_T as a factor in causing dispersion.

This conclusion is probably true for rockets in general. Some people go further and claim that one may ignore all but the L term in the formula for dispersion. Accordingly, they use the L term alone as a formula for dispersion. This gives a wonderfully simple formula, but we are not convinced that this simplification is legitimate.

Consider the term $(g \cos \theta_a/G)G_1$. For a fast-accelerating, short-burning-distance rocket like the M8, $G = 200g$ and $G_1 = -0.5$ would be roughly typical. Then $(g \cos \theta_a/G)G_1$ is roughly of the order of 0.003 rad, and the difference between $(g \cos \theta_a/G)G_1$ and $(g \cos \theta_a/G_s)G_1$ would be negligible as a term in the total dispersion. On the other hand, consider a slowly accelerating, long-burning-distance rocket for which the thrust is very dependent on the conditions of launching. Then $G = 50g$, $G_s = 40g$, $G_1 = -1.0$ would be roughly typical. Consequently,

$$\left(\frac{g \cos \theta_a}{G} - \frac{g \cos \theta_a}{G_s} \right) G_1$$

is roughly of the order of 0.005 rad, which is often not negligible as a term in the total dispersion.

To decide for a given rocket which terms besides δ_T are negligible, if any, in the equation for dispersion requires a knowledge of the likely values of the various physical quantities such as L , δ_T , δ_p , G , etc., that appear in the equation. Up to the present time, such knowledge has seldom been available. In the next section, for the sake of a numerical example we assume certain values of δ_T , L , δ_M , G , δ_p , and ϕ_p , but these values are only assumptions and are not to be considered typical.

Solution of the Equations.—We proceed with our solution of the equations of motion. The next step is to eliminate v^2 and $v(dv/ds)$ from (III.1.2) and (III.1.3) by means of (III.1.4) and (III.1.1). There results

$$2s \frac{d\theta}{ds} = \delta - \delta_T - \frac{g \cos \theta_a}{G} \quad (\text{III.1.12})$$

$$2s \frac{d^2\phi}{ds^2} + \frac{d\phi}{ds} = \frac{L}{k^2} - \frac{8\pi^2 s}{\sigma^2} (\delta - \delta_M) \quad (\text{III.1.13})$$

From these two equations, we can now deduce a single equation in δ . To do so, divide (III.1.12) by $2\sqrt{s}$ and differentiate both sides with respect to s . There results

$$\begin{aligned} \sqrt{s} \frac{d^2\theta}{ds^2} + \frac{1}{2\sqrt{s}} \frac{d\theta}{ds} &= \frac{1}{2\sqrt{s}} \frac{d\delta}{ds} \\ &\quad - \frac{1}{4s\sqrt{s}} \left(\delta - \delta_T - \frac{g \cos \theta_a}{G} \right) \end{aligned} \quad (\text{III.1.14})$$

We now divide (III.1.13) by $2\sqrt{s}$ and subtract (III.1.14). If we recall that $\delta = \phi - \theta$, we can write the result as

$$\begin{aligned} \sqrt{s} \frac{d^2\delta}{ds^2} + \frac{1}{\sqrt{s}} \frac{d\delta}{ds} + \left(\frac{4\pi^2 \sqrt{s}}{\sigma^2} - \frac{1}{4s\sqrt{s}} \right) \delta \\ = \frac{L}{2k^2 \sqrt{s}} + \frac{4\pi^2 \sqrt{s}}{\sigma^2} \delta_M - \frac{1}{4s\sqrt{s}} \left(\delta_T + \frac{g \cos \theta_a}{G} \right) \end{aligned}$$

This does not appear so formidable if we rewrite it in the equivalent form

$$\begin{aligned} \frac{d^2}{ds^2} (\sqrt{s}\delta) + \frac{4\pi^2}{\sigma^2} (\sqrt{s}\delta) &= \frac{L}{2k^2 \sqrt{s}} + \frac{4\pi^2 \sqrt{s}}{\sigma^2} \delta_M \\ &\quad - \frac{1}{4s\sqrt{s}} \left(\delta_T + \frac{g \cos \theta_a}{G} \right) \end{aligned} \quad (\text{III.1.15})$$

To simplify this still further, we introduce the dimensionless distance

$$S = \frac{2\pi s}{\sigma} \quad (\text{III.1.16})$$

Then for any variable X , we have

$$\frac{dX}{ds} = \frac{dX}{dS} \frac{dS}{ds} = \frac{2\pi}{\sigma} \frac{dX}{dS}, \quad \frac{d^2X}{ds^2} = \frac{4\pi^2}{\sigma^2} \frac{d^2X}{dS^2}$$

Accordingly, (III.1.15) takes the form

$$\begin{aligned} \frac{d^2}{dS^2} (\sqrt{S} \delta) + \sqrt{S} \delta &= \frac{\sigma L}{4\pi k^2 \sqrt{S}} \\ &+ \sqrt{S} \delta_M - \frac{1}{4S \sqrt{S}} \left(\delta_T + \frac{g \cos \theta_a}{G} \right) \end{aligned} \quad (\text{III.1.17})$$

and (III.1.12) takes the form

$$2S \frac{d\theta}{dS} = \delta - \delta_T - \frac{g \cos \theta_a}{G} \quad (\text{III.1.18})$$

We introduce the notation that a prime shall denote differentiation with respect to S . Also, P shall denote the value of S at the end of the launcher. By (III.1.16),

$$P = \frac{2\pi p}{\sigma} \quad (\text{III.1.19})$$

We wish boundary conditions for $\sqrt{S} \delta$ and $d(\sqrt{S} \delta)/dS$ in terms of the customary boundary conditions, namely, the values v_p , θ_p , δ_p , and ϕ_p . It is convenient to use ϕ'_p instead of ϕ_p . We have

$$\phi' = \frac{d\phi}{dS} = \frac{d\phi}{dt} \frac{dt}{ds} \frac{ds}{dS} = \frac{\sigma \phi}{2\pi v} \quad (\text{III.1.20})$$

So

$$\phi'_p = \frac{\sigma \phi_p}{2\pi v_p} \quad (\text{III.1.21})$$

By putting $S = P$ in (III.1.18), we get

$$\sqrt{P} \theta'_p = \frac{\delta_p - \delta_T - (g \cos \theta_a/G)}{2 \sqrt{P}}$$

Since $\theta = \phi - \delta$, we get

$$\sqrt{P} \delta'_p + \frac{\delta_p}{2 \sqrt{P}} = \sqrt{P} \phi'_p + \frac{\delta_T + (g \cos \theta_a/G)}{2 \sqrt{P}}$$

So our boundary conditions for the solution of (III.1.17) are that $\sqrt{S} \delta$ and $d(\sqrt{S} \delta)/dS$ equal $\sqrt{P} \delta_p$ and

$$\sqrt{P} \phi'_p + \frac{\delta_T + (g \cos \theta_a/G)}{2 \sqrt{P}}$$

respectively, when $S = P$.

To simplify our next step, we derive a mathematical result that will be useful later as well as now.

Consider the equation

$$\frac{d^2Z}{dS^2} + Z = Q(S) \quad (\text{III.1.22})$$

subject to the boundary conditions $Z = A$ and $dZ/dS = B$ when $S = P$. By direct substitution, we verify that

$$Z = \frac{1}{2j} \left[A_j + B + \int_P^S e^{-j(S-P)} Q(S) dS \right] e^{j(S-P)} \\ + \frac{1}{2j} \left[A_j - B - \int_P^S e^{j(S-P)} Q(S) dS \right] e^{-j(S-P)} \quad (\text{III.1.23})$$

is the solution of (III.1.22) satisfying the given boundary conditions. By writing

$$e^{\pm js} = \cos S \pm j \sin S$$

we can express (III.1.23) in the following "real" form:

$$Z = \cos(S - P) \left[A - \int_P^S \sin(S - P) Q(S) dS \right] \\ + \sin(S - P) \left[B + \int_P^S \cos(S - P) Q(S) dS \right] \quad (\text{III.1.24})$$

In order to apply this result to the solution of (III.1.17), we put

$$Z = \sqrt{S} \delta$$

$$A = \sqrt{P} \delta_p$$

$$B = \sqrt{P} \phi'_p + \frac{\delta_T + (g \cos \theta_a / G)}{2 \sqrt{P}}$$

$$Q(S) = \frac{\sigma L}{4\pi k^2 \sqrt{S}} + \sqrt{S} \delta_M - \frac{1}{4S \sqrt{S}} \left(\delta_T + \frac{g \cos \theta_a}{G} \right)$$

Then either (III.1.23) or (III.1.24) will give the solution of (III.1.17).

The various integrals arising in (III.1.23) and (III.1.24) can be expressed in terms of Fresnel integrals but it will be much easier to use the "rocket functions," which are defined in Chap. V and are purposely designed to express these and subsequent integrals.

By (V.3.1),

$$\int_P^S \frac{e^{-js}}{\sqrt{S}} dS = jrc(S)e^{-js} - jrc(P)e^{-jP}$$

Multiplying by e^{jP} gives

$$\int_P^S \frac{e^{-j(S-P)}}{\sqrt{S}} dS = jrc(S)e^{-j(S-P)} - jrc(P) \quad (\text{III.1.25})$$

Taking the conjugate complex of both sides, we get

$$\int_P^S \frac{e^{j(s-P)}}{\sqrt{S}} dS = -j\overline{rc}(S)e^{j(s-P)} + j\overline{rc}(P) \quad \text{(III.1.26)}$$

where

$$\overline{rc}(w) = rr(w) - jrc(w) \quad \text{(III.1.27)}$$

[see(V.1.3)]. In a similar fashion, from (V.3.4), we get

$$\int_P^S \sqrt{S} e^{-j(s-P)} dS = j\sqrt{S} e^{-j(s-P)} - j\sqrt{P} + \frac{1}{2}rc(S)e^{-j(s-P)} - \frac{1}{2}rc(P)$$

$$\int_P^S \sqrt{S} e^{j(s-P)} dS = -j\sqrt{S} e^{j(s-P)} + j\sqrt{P} + \frac{1}{2}\overline{rc}(S)e^{j(s-P)} - \frac{1}{2}\overline{rc}(P)$$

and from (V.3.5) and (V.1.13) we get

$$\int_P^S \frac{e^{-j(s-P)}}{S\sqrt{S}} dS = -\frac{2e^{-j(s-P)}}{\sqrt{S}} + \frac{2}{\sqrt{P}} + 2rc(S)e^{-j(s-P)} - 2rc(P)$$

$$\int_P^S \frac{e^{j(s-P)}}{S\sqrt{S}} dS = -\frac{2e^{j(s-P)}}{\sqrt{S}} + \frac{2}{\sqrt{P}} + 2\overline{rc}(S)e^{j(s-P)} - 2\overline{rc}(P)$$

Using these integrals in (III.1.23), we get

$$\delta = \delta_M + \left(\delta_T + \frac{g \cos \theta_a}{G} \right) F_1 + \frac{\sigma L}{2\pi k^2} F_2 - \delta_M(F_1 + F_3) + \delta_P F_3 + \phi'_P F_4 \quad \text{(III.1.28)}$$

where

$$F_1 = F_1(S,P) = \frac{j}{4\sqrt{S}} [rc(S) - rc(P)e^{j(s-P)} - \overline{rc}(S) + \overline{rc}(P)e^{-j(s-P)}] \quad \text{(III.1.29)}$$

$$F_2 = F_2(S,P) = \frac{1}{4\sqrt{S}} [rc(S) - rc(P)e^{j(s-P)} + \overline{rc}(S) - \overline{rc}(P)e^{-j(s-P)}] \quad \text{(III.1.30)}$$

$$F_3 = F_3(S,P) = \frac{\sqrt{P}}{2\sqrt{S}} [e^{j(s-P)} + e^{-j(s-P)}] \quad \text{(III.1.31)}$$

$$F_4 = F_4(S,P) = \frac{\sqrt{P}}{2\sqrt{S}} [je^{-j(s-P)} - je^{j(s-P)}] \quad \text{(III.1.32)}$$

By use of (V.1.3) and (III.1.27), (III.1.29) to (III.1.32), inclusive, could be written in a real form not involving j . We shall do so in due course, but for the various integrations which still have to be performed it is easier to leave the formula in the complex form.

We wish a formula for δ' . One could differentiate (III.1.28) by means of the formulas in Sec. 2 of Chap. V. However, a far easier way is to differentiate both sides of (III.1.23), getting

$$Z' = \frac{1}{2} \left[Aj + B + \int_P^S e^{-j(s-P)} Q(S) dS \right] e^{j(s-P)} - \frac{1}{2} \left[Aj - B - \int_P^S e^{j(s-P)} Q(S) dS \right] e^{-j(s-P)} \quad (\text{III.1.33})$$

Since $Z = \sqrt{S} \delta$,

$$\delta' = \frac{Z'}{\sqrt{S}} - \frac{\delta}{2S}$$

Therefore,

$$\delta' = -\frac{1}{2S} \left(\delta - \delta_T - \frac{g \cos \theta_a}{G} \right) - \left(\delta_T + \frac{g \cos \theta_a}{G} \right) F_2 + \frac{\sigma L}{2\pi k^2} F_1 + \delta_M (F_2 + F_4) - \delta_P F_4 + \phi'_P F_3 \quad (\text{III.1.34})$$

To compute θ , we have by (III.1.18)

$$\theta = \theta_P + \int_P^S \frac{\delta - \delta_T - (g \cos \theta_a / G)}{2S} dS \quad (\text{III.1.35})$$

This is clearly equivalent to

$$\theta = \theta_P + \delta_P - \delta + \int_P^S \left[\delta' + \frac{\delta - \delta_T - (g \cos \theta_a / G)}{2S} \right] dS \quad (\text{III.1.36})$$

which is much easier to use. By this and (III.1.34), we find, by use of (V.3.6), (III.1.25), and (III.1.26), the relation

$$\theta = \theta_P + \left(\delta_T + \frac{g \cos \theta_a}{G} \right) G_1 + \frac{\sigma L}{2\pi k^2} G_2 - \delta_M (G_1 + G_3) + \delta_P G_3 + \phi'_P G_4 \quad (\text{III.1.37})$$

where, using the notation

$$\bar{ic}(w) = \int_0^w \frac{\bar{rc}(x) dx}{\sqrt{x}} = ir(w) - jij(w) \quad (\text{III.1.38})$$

the functions G_1 , G_2 , G_3 , and G_4 are defined by

$$G_1 = G_1(S, P) = \frac{1}{2} [ic(P) - ic(S) + \bar{ic}(P) - \bar{ic}(S) - jrc(P)\bar{rc}(S)e^{j(s-P)} + j\bar{rc}(P)rc(S)e^{-j(s-P)}] - F_1 \quad (\text{III.1.39})$$

$$G_2 = G_2(S, P) = \frac{1}{2}[jic(S) - jic(P) - j\bar{ic}(S) + j\bar{ic}(P) - rc(P)\bar{rc}(S)e^{i(S-P)} - \bar{rc}(P)rc(S)e^{-i(S-P)} + 2rc(P)\bar{rc}(P)] - F_2 \quad (\text{III.1.40})$$

$$G_3 = G_3(S, P) = 1 + \frac{\sqrt{P}}{2} [\bar{rc}(S)e^{i(S-P)} - \bar{rc}(P) + rc(S)e^{-i(S-P)} - rc(P)] - F_3 \quad (\text{III.1.41})$$

$$G_4 = G_4(S, P) = \frac{\sqrt{P}}{2} [j\bar{rc}(P) - jrc(P) - j\bar{rc}(S)e^{i(S-P)} + jrc(S)e^{-i(S-P)}] - F_4 \quad (\text{III.1.42})$$

The deviation of the rocket from the approximate trajectory is given by

$$\eta = \int_p^s (\theta - \theta_a) ds = \frac{\sigma}{2\pi} \int_P^S (\theta - \theta_a) dS$$

So we get

$$\begin{aligned} \frac{2\pi\eta}{\sigma} &= (\theta_p - \theta_a)(S - P) + \left(\delta_r + \frac{g \cos \theta_a}{G} \right) \int_P^S G_1 dS \\ &+ \frac{\sigma L}{2\pi k^2} \int_P^S G_2 dS - \delta_M \int_P^S (G_1 + G_3) dS \\ &+ \delta_p \int_P^S G_3 dS + \phi'_p \int_P^S G_4 dS \end{aligned} \quad (\text{III.1.43})$$

By means of (V.3.16), (V.3.20), (V.1.13), (III.1.25), and (III.1.26), we can prove

$$\int_P^S G_1 dS = SG_1 - \frac{1}{2}G_2 + \frac{1}{2}(S - P) - \frac{1}{2}F_2 \quad (\text{III.1.44})$$

$$\int_P^S G_2 dS = SG_2 + \frac{1}{2}G_1 + \frac{1}{2}F_1 \quad (\text{III.1.45})$$

$$\int_P^S G_3 dS = SG_3 - \frac{1}{2}G_4 - \frac{1}{2}F_4 \quad (\text{III.1.46})$$

$$\int_P^S G_4 dS = SG_4 + \frac{1}{2}G_3 - \frac{1}{2} + \frac{1}{2}F_3 \quad (\text{III.1.47})$$

We now eliminate explicit occurrences of j from the above formulas, making much use of (V.1.13). For instance,

$$\begin{aligned} rc(P)e^{i(S-P)} &= ra(P)e^{[S-P+rt(P)]} \\ &= ra(P) \{ \cos [S - P + rt(P)] + j \sin [S - P + rt(P)] \} \end{aligned}$$

We obtain

$$F_1 = \frac{1}{2\sqrt{S}} \{ ra(P) \sin [S - P + rt(P)] - rj(S) \} \quad (\text{III.1.48})$$

$$F_2 = \frac{1}{2\sqrt{S}} \{rr(S) - ra(P) \cos [S - P + rt(P)]\} \quad (\text{III.1.49})$$

$$F_3 = \frac{\sqrt{P}}{\sqrt{S}} \cos (S - P) \quad (\text{III.1.50})$$

$$F_4 = \frac{\sqrt{P}}{\sqrt{S}} \sin (S - P) \quad (\text{III.1.51})$$

$$G_1 = \frac{1}{2} \{ir(P) - ir(S) + ra(P)ra(S) \sin [S - rt(S) - P + rt(P)]\} - F_1 \quad (\text{III.1.52})$$

$$G_2 = \frac{1}{2} \{ra^2(S) + ra^2(P) - 2ra(P)ra(S) \cos [S - rt(S) - P + rt(P)]\} - F_2 \quad (\text{III.1.53})$$

$$G_3 = 1 + \sqrt{P} \{ra(S) \cos [S - rt(S) - P] - rr(P)\} - F_3 \quad (\text{III.1.54})$$

$$G_4 = \sqrt{P} \{rj(P) + ra(S) \sin [S - rt(S) - P]\} - F_4 \quad (\text{III.1.55})$$

If we substitute (III.1.48) to (III.1.51) back into (III.1.28), we see that, except for the terms $rr(S)/\sqrt{S}$ and $rj(S)/\sqrt{S}$, which go to zero rapidly as S increases, δ performs a slowly damped oscillation about the value δ_M .

When we substitute (III.1.48) to (III.1.51) back into (III.1.28), the result appears to be a real equation. However, it must be recalled that δ_M , δ_T , L , δ_p , and ϕ'_p are complex, so that (III.1.28) is an equation for the complex quantity δ . One can get the vertical and horizontal components of δ by taking the real and imaginary parts of (III.1.28).

By use of (V.1.14) and (V.1.15), the equations (III.1.48) to (III.1.55) can be given the alternative forms

$$F_1 = \frac{1}{2\sqrt{S}} [rr(P) \sin (S - P) + rj(P) \cos (S - P) - rj(S)] \quad (\text{III.1.56})$$

$$F_2 = \frac{1}{2\sqrt{S}} [rr(S) - rr(P) \cos (S - P) + rj(P) \sin (S - P)] \quad (\text{III.1.57})$$

$$G_1 = \frac{1}{2} \left\{ ir(P) - ir(S) + rr(P) \left[rr(S) - \frac{1}{\sqrt{S}} \right] \sin (S - P) + rj(P)rj(S) \sin (S - P) + rj(P) \left[rr(S) - \frac{1}{\sqrt{S}} \right] \cos (S - P) - rr(P)rj(S) \cos (S - P) + \frac{rj(S)}{\sqrt{S}} \right\} \quad (\text{III.1.58})$$

$$G_2 = \frac{1}{4} \left\{ ra^2(S) + ra^2(P) - 2rr(P) \left[rr(S) - \frac{1}{\sqrt{S}} \right] \cos(S - P) \right. \\ \left. - 2rj(P)rj(S) \cos(S - P) + 2rj(P) \left[rr(S) - \frac{1}{\sqrt{S}} \right] \sin(S - P) \right. \\ \left. - 2rr(P)rj(S) \sin(S - P) - \frac{2rr(S)}{\sqrt{S}} \right\} \quad (\text{III.1.59})$$

$$G_3 = 1 + \sqrt{P} \left\{ \left[rr(S) - \frac{1}{\sqrt{S}} \right] \cos(S - P) + rj(S) \sin(S - P) \right. \\ \left. - rr(P) \right\} \quad (\text{III.1.60})$$

$$G_4 = \sqrt{P} \left\{ rj(P) + \left[rr(S) - \frac{1}{\sqrt{S}} \right] \sin(S - P) \right. \\ \left. - rj(S) \cos(S - P) \right\} \quad (\text{III.1.61})$$

If we make use of the asymptotic formulas (V.7.4), (V.7.5), and (V.7.12) in the above, we can deduce

$$G_1 \cong \frac{1}{2}[ir(P) - ir(S)] \quad (\text{III.1.62})$$

$$G_2 \cong \frac{1}{4} \left[ra^2(P) - \frac{1}{S} \right] \quad (\text{III.1.63})$$

$$G_3 \cong 1 - \sqrt{P} rr(P) \quad (\text{III.1.64})$$

$$G_4 \cong \sqrt{P} rj(P) \quad (\text{III.1.65})$$

$$\int_P^S G_1 dS \cong SG_1 - \frac{1}{2}G_2 + \frac{1}{2}(S - P) \quad (\text{III.1.66})$$

$$\int_P^S G_2 dS \cong SG_2 + \frac{1}{2}G_1 \quad (\text{III.1.67})$$

$$\int_P^S G_3 dS \cong SG_3 - \frac{1}{2}G_4 \quad (\text{III.1.68})$$

$$\int_P^S G_4 dS \cong SG_4 + \frac{1}{2}G_3 - \frac{1}{2} \quad (\text{III.1.69})$$

The reader will recognize (III.1.62) to (III.1.65) as the approximations that we gave earlier for $s - p$ not too near zero in (III.1.7) to (III.1.10). The approximations that we gave for $s - p$ near zero are just the vacuum solution that we shall derive in Sec. 6 below. The errors in (III.1.62) to (III.1.65) are of the order of $1/S \sqrt{S}$; in (III.1.66) to (III.1.69) they are of the order of $1/\sqrt{S}$.

2. Numerical Examples

First Example.—As our first example, consider a rocket with an acceleration of 6,000 ft/sec², a burning time of 0.15 sec, a radius of

gyration equal to 0.75 ft, and a wave length of yaw of 200 ft. Let us launch it through a tube 6 ft long, starting it from rest. Then $p = 6$ ft. We thus have

$$\begin{aligned} G &= 6,000 \\ k &= 0.75 \\ \sigma &= 200 \\ p &= 6 \end{aligned}$$

whence, by (III.1.5) and (III.1.19),

$$\begin{aligned} v_p &= \sqrt{2(6,000)6} = 268.3 \\ P &= \frac{(2\pi)6}{200} = 0.1885 \end{aligned}$$

Let us suppose that these values happen to be the same as for the standard rocket so that

$$v_{ps} = 268.3$$

Let us suppose further that for this particular (nonstandard) rocket the components of L and δ_T in the vertical plane are zero, whereas the component of δ_M is 0.01 rad. In the horizontal plane let the components of L and δ_T be 0.05 in. ($= 0.00417$ ft) and 0.005 rad, while the component of δ_M is zero. So

$$\begin{aligned} L &= 0.00417j \\ \frac{\sigma L}{2\pi k^2} &= 0.2360j \\ \delta_T &= 0.005j \\ \delta_M &= 0.010 \end{aligned}$$

Let us have the launcher elevated at an angle of 15° ($= 0.26180$ rad) to the horizontal. We shall not bother to use the formulas of Chap. IV to find the precise launching conditions but shall merely assume some suitable values.

For the standard rocket at launching, ϕ equals -0.1 rad/sec and the rocket makes an angle of 0.00018 rad below the launcher. So

$$\begin{aligned} \phi_{ps} &= -0.1 \\ \phi_{ps} &= 0.26180 - 0.00018 = 0.26162 \end{aligned}$$

By (III.1.21),

$$\phi'_{ps} = \frac{(-0.1)(200)}{2\pi(268.3)} = -0.01186$$

We can use the above information to compute the value of θ at launching. At launching, the tail of the rocket is just leaving the launching tube, hence is still on the launcher, and hence is still moving

along the launcher line. As $\phi = -0.1$ rad/sec, the center of gravity must be moving perpendicular to the launcher. In fact, if the tail is 1.8 ft from the center of gravity, then the center of gravity must be moving perpendicular to the launcher at a rate of

$$(-0.1)(1.8) = -0.18 \text{ ft/sec}$$

Combining this with the velocity of 268.3 ft/sec in the direction of the launcher, we get a total velocity of 268.3 ft/sec at an angle

$$\arctan \frac{0.18}{268.3} = 0.00067 \text{ rad}$$

below the elevation of the launcher. So

$$\theta_{ps} = 0.26180 - 0.00067 = 0.26113$$

$$\delta_{ps} = \phi_{ps} - \theta_{ps} = 0.00049$$

For the particular (nonstandard) rocket that we are considering, the launching conditions are

$$\dot{\phi}_p = -0.1 + 0.1j$$

$$\phi_p = 0.26180 + (-0.00018 + 0.00018j)$$

$$= 0.26162 + 0.00018j$$

So

$$\phi'_p = -0.01186 + 0.01186j$$

An analysis similar to that for the standard rocket gives

$$\theta_p = 0.26180 + (-0.00067 + 0.00067j)$$

$$= 0.26113 + 0.00067j$$

$$\delta_p = \phi_p - \theta_p = 0.00049 - 0.00049j$$

θ_{ps} is a convenient value to use for θ_a , so that

$$\cos \theta_a = 0.9661$$

For both the particular rocket and the standard rocket

$$\begin{aligned} \frac{g \cos \theta_a}{G} &= \frac{(32.16)(0.9661)}{6,000} \\ &= 0.00518 \end{aligned}$$

To illustrate the lack of sensitivity to the value of θ_a , we remark that had we taken θ_a equal to 0.24435 ($= 14^\circ$) instead of 0.26113 , the value of $g \cos \theta_a/G$ would be changed only to 0.00520 , a change of less than $\frac{1}{2}$ per cent.

With a burning time of 0.15 sec, we have

$$v_b = Gt_b = (6,000)(0.15) = 900 \text{ ft/sec}$$

$$s_b = \frac{1}{2}G(t_b)^2 = (3,000)(0.15)^2 = 67.5 \text{ ft}$$

So, to get conditions at the end of burning, we put

$$S = S_b = \frac{(2\pi)(67.5)}{200} = 2.1206$$

From the tables in Chap. V, using linear interpolation and keeping only 4 decimal places,

$rr(2.1206) = 0.6288$	$rr(0.1885) = 1.1049$
$rj(2.1206) = 0.1137$	$rj(0.1885) = 0.6059$
$ra^2(2.1206) = 0.4083$	$ra^2(0.1885) = 1.5880$
$ir(2.1206) = 2.7705$	$ir(0.1885) = 1.0398$
$ra(2.1206) = 0.6390$	$ra(0.1885) = 1.2602$
$rt(2.1206) = 0.1788$	$rt(0.1885) = 0.5016$

The angles needed, together with their sines and cosines, are

$S - P = 1.9321$	$\sin(1.9321) = 0.9354$
	$\cos(1.9321) = -0.3535$
$S - P + rt(P) = 2.4337$	$\sin(2.4337) = 0.6502$
	$\cos(2.4337) = -0.7597$
$S - rt(S) - P + rt(P) = 2.2549$	$\sin(2.2549) = 0.7750$
	$\cos(2.2549) = -0.6320$
$S - rt(S) - P = 1.7533$	$\sin(1.7533) = 0.9834$
	$\cos(1.7533) = -0.1815$

Then, by (III.1.48) to (III.1.51),

$$F_1 = \frac{1}{2\sqrt{2.1206}} [(1.2602)(0.6502) - 0.1137] = 0.2422$$

$$F_2 = \frac{1}{2\sqrt{2.1206}} [0.6288 - (1.2602)(-0.7597)] = 0.5446$$

$$F_3 = \frac{\sqrt{0.1885}(-0.3535)}{\sqrt{2.1206}} = -0.1054$$

$$F_4 = \frac{\sqrt{0.1885}(0.9354)}{\sqrt{2.1206}} = 0.2789$$

Then, by (III.1.52) to (III.1.55),

$$G_1 = \frac{1}{2}[1.0398 - 2.7705 + (1.2602)(0.6390)(0.7750)] - 0.2422$$

$$= -0.7956$$

$$G_2 = \frac{1}{2}[0.4083 + 1.5880 - 2(1.2602)(0.6390)(-0.6320)] - 0.5446$$

$$= 0.2089$$

$$\begin{aligned}
 G_3 &= 1 + \sqrt{0.1885} [0.6390(-0.1815) - 1.1049] + 0.1054 \\
 &= 0.5753 \\
 G_4 &= \sqrt{0.1885} [0.6059 + (0.6390)(0.9834)] - 0.2789 \\
 &= 0.2570
 \end{aligned}$$

By (III.1.11), a value for the dispersion of the rocket is given by

$$\begin{aligned}
 \theta - \theta_0 &= 0.00067j + (0.005j)(-0.7956) + (0.2360j)(0.2089) \\
 &\quad - (0.010)(-0.7956 + 0.5753) + (-0.00049j)(0.5753) \\
 &\quad\quad\quad + (0.01183j)(0.2570) \\
 &= 0.0007j - 0.0040j + 0.0493j + 0.0022 - 0.0003j + 0.0030j
 \end{aligned}$$

Before combining these terms into a final value for dispersion, it is of interest to identify them. We refer back to (III.1.11) for their source. The first term, $0.001j$, is due to an initial incorrect direction of motion of the center of gravity, of amount $0.001j$. The second term, $-0.004j$, is due to the jet malalignment angle δ_T , of amount $0.005j$. The third term, $0.049j$, is due to the jet malalignment distance L , of amount $0.00417j$. The fourth term, 0.002 , is due to the fin malalignment angle δ_M , of amount 0.010 . The fifth term, essentially zero, is due to the initial yaw δ_p , of amount $-0.00049j$. The final term, $0.003j$, is due to the initial angular velocity ϕ_p , of amount $0.1j$.

In the present circumstance, it is certainly true that the L term dominates. It gives $0.049j$ for the dispersion, while all terms combined give $0.002 + 0.049j$ for the dispersion.

Although this quantity which we have computed is often used for the dispersion, it is actually just the latent dispersion at the end of burning. A more accurate value of the dispersion will be obtained by adding the dispersion after burning, as computed by the formulas of Chap. II. To apply these, we need v_b , δ_b , and δ'_b , of which we have v_b already. By (III.1.28),

$$\begin{aligned}
 \delta_b &= 0.010 + (0.005j + 0.00518)(0.2422) + (0.2360j)(0.5446) \\
 &\quad - (0.010)(0.2422 - 0.1054) \\
 &\quad\quad\quad + (0.00049 - 0.00049j)(-0.1054) \\
 &\quad\quad\quad\quad\quad\quad + (-0.01186 + 0.01186j)(0.2789) \\
 &= 0.0066 + 0.1331j
 \end{aligned}$$

By (III.1.34),

$$\begin{aligned}
 \delta'_b &= -\frac{1}{2(2.1206)} (0.0066 + 0.1298j - 0.005j - 0.00518) \\
 &\quad - (0.005j + 0.00518)(0.5446) + (0.2360j)(0.2422) \\
 &\quad + (0.010)(0.5446 + 0.2789) \\
 &\quad - (0.00049 - 0.00049j)(0.2789) \\
 &\quad\quad\quad + (-0.01186 + 0.01186j)(-0.1054) \\
 &= 0.0062 + 0.0239j
 \end{aligned}$$

The yaw at the end of burning, being more than 0.1 rad in absolute value, is quite a large yaw. In fact, this rocket is definitely a very inaccurate rocket, since its dispersion of the order of 0.050 rad is quite large, even for a rocket.

For such an inaccurate rocket as this, only a rough computation of the dispersion would be made. Doubtless the dispersion after burning would be neglected. Also, the values of G_1 , G_2 , G_3 , and G_4 would be computed by the formulas (III.1.7) to (III.1.10). These give

$$G_1 = \frac{1}{3}[ir(P) - ir(S)] = -0.865$$

$$G_2 = \frac{(\sqrt{S} - \sqrt{P})^2}{3\sqrt{S}} = 0.244$$

$$G_3 = 1 - \sqrt{P} rr(P) = 0.520$$

$$G_4 = \sqrt{P} rj(P) = 0.263$$

These compare very favorably with the more exact values

$$G_1 = -0.796$$

$$G_2 = 0.209$$

$$G_3 = 0.575$$

$$G_4 = 0.257$$

The error in using the approximate values of G_1 , G_2 , G_3 , and G_4 is probably no more than the error arising from neglecting the dispersion after burning. We also remark that the values of S and P used above are in the region where our approximate formulas are at their poorest, so that this shows the approximation at its worst. Nevertheless, the approximation gives a sufficiently accurate value of the dispersion for many purposes.

It is seldom that any more data at the end of burning are desired than we have already computed, particularly for a rocket of poor accuracy such as the present one, but to illustrate the methods involved we shall compute the complete set of data at the end of burning for this rocket before we proceed to our second example.

From (III.1.18), we get

$$\begin{aligned} \theta'_b &= \frac{\delta_b - \delta_T - [(g \cos \theta_a)/G]}{2S_b} \\ &= 0.0003 + 0.0313j \end{aligned}$$

Then

$$\phi'_b = \theta'_b + \delta'_b = 0.0065 + 0.0552j$$

By (III.1.20)

$$\begin{aligned}\phi_b &= \frac{(2\pi)(900)}{200} (0.0065 + 0.0552j) \\ &= 0.184 + 1.561j\end{aligned}$$

By (III.1.6) or (III.1.37)

$$\begin{aligned}\theta_b &= 0.26113 + 0.00067j \\ &\quad + (0.005j + 0.00518)(-0.7956) \\ &\quad + (0.2360j)(0.2089) \\ &\quad - (0.010)(-0.7956 + 0.5753) \\ &\quad + (0.00049 - 0.00049j)(0.5753) \\ &\quad \quad \quad + (-0.01186 + 0.01186j)(0.2570) \\ &= 0.2564 + 0.0488j\end{aligned}$$

Then

$$\begin{aligned}\phi_b &= \theta_b + \delta_b \\ &= 0.2630 + 0.1819j\end{aligned}$$

We now have ϕ_b and $\dot{\phi}_b$, which give the orientation of the rocket and the rate of change of this orientation at the end of burning.

In the vertical plane

$$\theta_b = 0.2564 \text{ rad} = 14^\circ 41'$$

So, by (I.3.1) and (I.3.2),

$$\begin{aligned}\dot{x} &= (900)(0.9673) = 871 \text{ ft/sec} \\ \dot{y} &= (900)(0.2536) = 228 \text{ ft/sec}\end{aligned}$$

In the horizontal plane

$$\theta_b = 0.0487 \text{ rad} = 2^\circ 47'$$

So, for the y in the horizontal plane,

$$\dot{y} = (900)(0.0487) = 44 \text{ ft/sec}$$

This is the velocity perpendicular to the vertical plane.

It remains to find the position at the end of burning. The end of the approximate trajectory is 61.5 ft beyond the end of the launcher, and the approximate trajectory makes an angle of

$$\theta_a = 0.26113 \text{ rad} = 14^\circ 58'$$

with the horizontal. So if the start of the launcher is taken as the origin, then the end of the approximate trajectory has coordinates

$$\begin{aligned}
 x &= 6 \cos 15^\circ + 61.5 \cos 14^\circ 58' \\
 &= 65 \text{ ft} \\
 y &= 6 \sin 15^\circ + 61.5 \sin 14^\circ 58' \\
 &= 17 \text{ ft}
 \end{aligned}$$

To find how far the rocket is from the end of the trajectory, we first use (III.1.44) to (III.1.47), getting

$$\begin{aligned}
 \int_P^S G_1 dS &= (2.1206)(-0.7956) - \frac{1}{2}(0.2089) \\
 &\quad + \frac{1}{2}(2.1206 - 0.1885) - \frac{1}{2}(0.5446) \\
 &= -1.098
 \end{aligned}$$

$$\begin{aligned}
 \int_P^S G_2 dS &= (2.1206)(0.2089) + \frac{1}{2}(-0.7956) + \frac{1}{2}(0.2422) \\
 &= 0.166
 \end{aligned}$$

$$\begin{aligned}
 \int_P^S G_3 dS &= (2.1206)(0.5753) - \frac{1}{2}(0.2570) - \frac{1}{2}(0.2789) \\
 &= 0.952
 \end{aligned}$$

$$\begin{aligned}
 \int_P^S G_4 dS &= (2.1206)(0.2570) + \frac{1}{2}(0.5753) - \frac{1}{2} + \frac{1}{2}(-0.1054) \\
 &= 0.280
 \end{aligned}$$

Then by (III.1.43), the deviation of the rocket from the approximate trajectory is

$$\begin{aligned}
 \eta_b &= \frac{200}{2\pi} [(0.00067j)(2.1206 - 0.1885) \\
 &\quad + (0.005j + 0.00518)(-1.098) + (0.2360j)(0.166) \\
 &\quad - (0.010)(-1.098 + 0.952) \\
 &\quad + (0.00049 - 0.00049j)(0.952) \\
 &\quad \quad + (-0.01186 + 0.01186j)(0.280)] \\
 &= -0.2 + 1.2j
 \end{aligned}$$

In other words, at the end of burning, the rocket has dropped 0.2 ft below the approximate trajectory and is 1.2 ft to one side of the approximate trajectory. These quantities can be ignored. It is seldom that the deviation of the rocket from its approximate trajectory during burning is of any consequence.

Second Example.—Consider this time a rocket with an acceleration of 3,000 ft/sec², a burning time of 0.30 sec, a radius of gyration equal to 0.75 ft, and a wave length of yaw of 200 ft. So

$$\begin{aligned}
 G &= 3,000 \\
 k &= 0.75 \\
 \sigma &= 200
 \end{aligned}$$

Let us suppose that the standard rocket has the same values. Let us launch this rocket from underneath the wing of an airplane flying horizontally at a speed of 500 ft/sec. It is launched from a zero-length launcher, that is, one in which the rocket is released from all constraints almost immediately upon being fired. At the time of launching, the rocket is to be pointing $\frac{1}{2}^\circ$ below the line of flight of the airplane.

At the time of launching, the rocket is traveling horizontally with the airplane, so that

$$\theta_p = \theta_{ps} = 0$$

Since the rocket points downward by $\frac{1}{2}^\circ$,

$$\delta_p = \delta_{ps} = -\frac{1}{2}^\circ = -0.00873$$

There is no angular velocity at the time of launching, since the rocket is released instantly upon firing and the airplane was flying steadily at the time of firing. So

$$\begin{aligned}\dot{\phi}_p &= \dot{\phi}_{ps} = 0 \\ \phi'_p &= \phi'_{ps} = 0\end{aligned}$$

Had the plane been maneuvering at the time of flying, then $\dot{\phi}_p$ would not have been zero.

Since the airplane is flying at 500 ft/sec and the rocket is released immediately upon firing,

$$v_p = v_{ps} = 500$$

Then by (III.1.5) and (III.1.19),

$$\begin{aligned}p &= \frac{(500)^2}{2(3,000)} = 41.667 \text{ ft} \\ P &= \frac{2\pi(41.667)}{200} = 1.3090\end{aligned}$$

Let L , δ_T , and δ_M be as in the first example, namely,

$$\begin{aligned}L &= 0.00417j \\ \frac{\sigma L}{2\pi k^2} &= 0.2360j \\ \delta_T &= 0.005j \\ \delta_M &= 0.010\end{aligned}$$

We put $\theta_a = 0$, naturally, so that

$$\frac{g \cos \theta_a}{G} = 0.01072$$

With a burning time of 0.30 sec and $G = 3,000$,

$$\begin{aligned} v_b &= 500 + (0.30)(3,000) \\ &= 1,400 \end{aligned}$$

So

$$\begin{aligned} s_b &= \frac{(1,400)^2}{2(3,000)} = 326.67 \\ S = S_b &= \frac{2\pi(326.67)}{200} = 10.263 \end{aligned}$$

Suppose that in this case we wish only the dispersion and intend to ignore the dispersion after burning. Then we need only the values of G_1 , G_2 , and G_3 (we do not need G_4 since $\phi'_p = \phi'_{ps} = 0$). For the large value of S that we have, the asymptotic formulas (III.1.62) to (III.1.65) will be quite accurate. That is to say, the approximate formulas (III.1.7) to (III.1.10) will be quite accurate. So, from the tables, we look up

$$\begin{aligned} ir(1.3090) &= 2.3431 & ir(10.2627) &= 4.2952 \\ rr(1.3090) &= 0.7458 & ra^2(1.3090) &= 0.5900 \end{aligned}$$

So

$$\begin{aligned} G_1 &= \frac{1}{2}(2.3431 - 4.2952) = -0.9760 \\ G_2 &= \frac{1}{4}\left(0.5900 - \frac{1}{10.263}\right) = 0.1231 \\ G_3 &= 1 - \sqrt{1.3090(0.7458)} = 0.1467 \end{aligned}$$

Then, by (III.1.11),

$$\begin{aligned} \theta - \theta_s &= (0.005j)(-0.9760) + (0.2360j)(0.1231) \\ &\quad - (0.010)(-0.9760 + 0.1467) \\ &= 0.0083 + 0.0242j \end{aligned}$$

In this case, the L term is less predominant. It alone is equal to $0.0291j$.

We wish to call attention to one important fact about firing from airplanes. By means of (III.1.6), let us compute θ_s at the end of burning.

$$\begin{aligned} \theta_s &= (0.01072)(-0.9760) + (-0.00873)(0.1467) \\ &= -0.01046 - 0.00128. \end{aligned}$$

The first term, -0.01046 , is the gravity drop. The second term, -0.00128 , is the downward direction of the trajectory due to the original downward tilt of the rocket. The significant point is that although the rocket started out with a downward tilt of -0.00873 , it actually has a resultant downward direction of only -0.00128 at the

end of burning. In other words, it is not going downward nearly as rapidly as might be expected from the original direction of the rocket.

The reason for this is fairly clear. As soon as the rocket is released from the launcher constraints, the aerodynamic forces due to the air stream can take effect. This air stream, acting on the fins, tends to turn the rocket head-on into the air stream. This effect is so pronounced at the speed of a fast airplane that the final direction of motion has little connection with the direction of the rocket at launching—as our numerical example showed. Instead, it is largely determined by the direction of the air stream, tending to be opposite to this direction.

This means that if a plane is skidding a bit sidewise at the time of firing, then an inaccurate shot will result, because the rocket will turn into the air stream instead of proceeding in the direction in which it was aimed.

3. The General Solution

We have to solve the three equations (I.5.18), (I.5.19), and (I.5.20) with F_1 , F_2 , and J set equal to zero. Dividing the first two by M and the third by Mk^2 , we have to solve

$$v \frac{dv}{ds} = G - g \sin \theta_a - k_D \rho d^2 v^2 \quad (\text{III.3.1})$$

$$v^2 \frac{d\theta}{ds} = G(\delta - \delta_T) - g \cos \theta_a + k_L \rho d^2 v^2 (\delta - \delta_L) + k_S \rho d^3 v^2 \frac{d\phi}{ds} \quad (\text{III.3.2})$$

$$v^2 \frac{d^2 \phi}{ds^2} + v \frac{dv}{ds} \frac{d\phi}{ds} = G \frac{L}{k^2} - k_M \rho d^3 v^2 (\delta - \delta_M) - k_H \rho d^4 v^2 \frac{d\phi}{ds} - \frac{mv}{Mk^2} \frac{d\phi}{ds} (r_i r_e - k^2) \quad (\text{III.3.3})$$

As long as the behavior of the coefficients k_D , k_L , etc., is not known, one cannot solve these equations, of course. Even if one does know the behavior of the coefficients, one probably cannot solve the equations exactly. However, one can solve them as exactly as desired by successive approximations, along the following lines:

(III.3.1) is nearly independent of everything except v , t , and s . Hence we can ignore the dependence on other quantities and solve the resulting approximation to (III.3.1) simultaneously with

$$\frac{ds}{dt} = v \quad (\text{III.3.4})$$

getting as a result a fairly accurate solution. This can then be used in (III.3.2) and (III.3.3), which can then be solved for θ , δ , and ϕ with the help of

$$\phi = \theta + \delta \quad (\text{III.3.5})$$

We now have fairly good approximations for ϕ , θ , and δ as functions of t . We substitute these into (III.3.1), getting a much better approximation to (III.3.1) than we obtained by simply ignoring the dependence on ϕ , θ , and δ . Solving this simultaneously with (III.3.4) gives a very accurate solution. This can now be used in (III.3.2), (III.3.3), and (III.3.5) to give very accurate solutions for ϕ , θ , and δ .

We thus have a cycle. Approximate values of ϕ , θ , and δ as functions of t can be put into (III.3.1), whence an approximate solution can then be found. This is then used with (III.3.2), (III.3.3), and (III.3.5) to get better approximate values of ϕ , θ , and δ as functions of t . One can repeat the cycle as often as necessary. In the present state of our knowledge of the behavior of k_D , k_L , etc., it would be pointless to go through the cycle more than once.

We now consider the steps of the cycle in detail.

Various degrees of approximation to (III.3.1) can be considered. The simplest, which is often quite adequate, is to ignore the gravity and drag terms in (III.3.1). This gives

$$v \frac{dv}{ds} = G$$

As $G = T/M$, and T and M are commonly known as functions of t (approximately at least), we write this in the alternative form

$$\dot{v} = G$$

Hence

$$v = \int G dt \quad (\text{III.3.6})$$

When G is reasonably constant, this simplifies to

$$v = Gt \quad (\text{III.3.7})$$

if we choose the origin of t properly. A proper choice of the origin for s gives

$$s = \frac{1}{2}Gt^2 \quad (\text{III.3.8})$$

$$v^2 = 2Gs \quad (\text{III.3.9})$$

If one chooses to retain the gravity and drag terms, one runs into the trouble that $k_D \rho d^2 v^2$ depends on y , δ , and v , as well as t . The dependence on y is through ρ , which is approximately equal to $\rho_0 \exp(-ay)$. Usually the variation of ρ throughout burning is much

too small to be considered, but if necessary one can take account of it by using an approximate value of y from the basic solution given in Sec. 1 above.

The dependence on δ is not great [see (I.2.6)]. Since the term involving k_D is small compared to G for most cases, small variations in this term can usually be ignored. If one wishes to take account of the variations due to changes in δ , one can use the δ from the basic solution of Sec. 1.

The dependence on v is through $K_D v^2$. Though K_D is independent of v for small v , it does vary considerably with v when v is near the speed of sound. By substituting for v from (III.3.6), the term $k_D \rho d^2 v^2$ is finally made to depend only on t . Then, since

$$\dot{v} = v \frac{dv}{ds}$$

we have from (III.3.1) that

$$v = \int (G - g \sin \theta_a - k_D \rho d^2 v^2) dt \quad (\text{III.3.10})$$

If we now use this instead of (III.3.6) to eliminate v from $K_D v^2$, a more accurate determination of v will result from solving (III.3.10). This in turn can be used to eliminate v from $K_D v^2$, with a still more accurate value of v resulting from solving (III.3.10). And so on, to whatever degree of accuracy our knowledge of K_D or G will justify.

When an adequate degree of accuracy has been attained, we get s by integrating v . Thus we now have v and s as functions of t , and hence as functions of each other, if desired.

We now proceed to study (III.3.2) and (III.3.3). By (III.3.5), we can write (III.3.2) in the form

$$(1 - k_S \rho d^3) v^2 \frac{d\theta}{ds} = G(\delta - \delta_T) - g \cos \theta_a + k_L \rho d^2 v^2 (\delta - \delta_L) + k_S \rho d^3 v^2 \frac{d\delta}{ds}$$

For the M8,

$$k_S \rho d^3 = 0.0022$$

and so we neglect this term on the left side of the above equation, with the result

$$v^2 \frac{d\theta}{ds} = G(\delta - \delta_T) - g \cos \theta_a + k_L \rho d^2 v^2 (\delta - \delta_L) + k_S \rho d^3 v^2 \frac{d\delta}{ds}$$

We divide by v ,

$$v \frac{d\theta}{ds} = \frac{G}{v} (\delta - \delta_T) - \frac{g \cos \theta_a}{v} + k_L \rho d^2 v (\delta - \delta_L) + k_S \rho d^3 v \frac{d\delta}{ds} \quad (\text{III.3.11})$$

We differentiate this with respect to s with the result

$$\begin{aligned}
 v \frac{d^2\theta}{ds^2} + \frac{dv}{ds} \frac{d\theta}{ds} &= (\delta - \delta_T) \frac{d}{ds} \left(\frac{G}{v} \right) + \frac{G}{v} \left(\frac{d\delta}{ds} - \frac{d\delta_T}{ds} \right) \\
 &+ \frac{dv}{ds} \frac{g \cos \theta_a}{v^2} + \frac{d}{ds} (k_{L\rho}) d^2v (\delta - \delta_L) \\
 &+ k_{L\rho} d^2 \frac{dv}{ds} (\delta - \delta_L) + k_{L\rho} d^2v \left(\frac{d\delta}{ds} - \frac{d\delta_L}{ds} \right) \\
 &+ \frac{d}{ds} (k_{s\rho}) d^3v \frac{d\delta}{ds} + k_{s\rho} d^3 \frac{dv}{ds} \frac{d\delta}{ds} + k_{s\rho} d^3v \frac{d^2\delta}{ds^2} \quad (\text{III.3.12})
 \end{aligned}$$

To simplify (III.3.3) a bit, we define a jet damping coefficient

$$k_J = \frac{\dot{m}}{Mk^2} (r_i r_o - k^2)$$

We now divide (III.3.3) by v and subtract (III.3.12) from the result We get, by (III.3.5),

$$\begin{aligned}
 v \frac{d^2\delta}{ds^2} (1 + k_{s\rho} d^3) + \frac{dv}{ds} \frac{d\delta}{ds} \left[1 + k_{s\rho} d^3 \right. \\
 \left. + d^3v \frac{d}{dv} (k_{s\rho}) + k_{L\rho} d^2v \frac{ds}{dv} + \frac{G}{v} \frac{ds}{dv} \right. \\
 \left. + k_{H\rho} d^4v \frac{ds}{dv} + k_J \frac{ds}{dv} \right] + \delta \left[k_{M\rho} d^3v \right. \\
 \left. + \frac{d}{ds} \left(\frac{G}{v} \right) + d^2v \frac{d}{ds} (k_{L\rho}) + k_{L\rho} d^2 \frac{dv}{ds} \right] \\
 = \frac{GL}{v k^2} + k_{M\rho} d^3v \delta_M - k_{H\rho} d^4v \frac{d\theta}{ds} \\
 - k_J \frac{d\theta}{ds} + \delta_T \frac{d}{ds} \left(\frac{G}{v} \right) + \frac{G}{v} \frac{d\delta_T}{ds} - \frac{dv}{ds} \frac{g \cos \theta_a}{v^2} \\
 \left. + \frac{d}{ds} (k_{L\rho} d^2v \delta_L) \quad (\text{III.3.13})
 \end{aligned}$$

As

$$k_{s\rho} d^3 = 0.0022$$

for the M8, we can neglect the occurrences of this term. To justify neglecting the term $(d/dv)(k_{s\rho})$ we write

$$\begin{aligned}
 \frac{d}{dv} (k_{s\rho}) &= \frac{d}{dv} \left(\frac{K_{s\rho}}{M} \right) \\
 &= \frac{dK_{s\rho}}{dv} \frac{\rho}{M} + \frac{d\rho}{dy} \frac{dy}{ds} \frac{ds}{dv} \frac{K_{s\rho}}{M} - \frac{dM}{dv} \frac{K_{s\rho}}{M^2}
 \end{aligned}$$

So

$$d^2v \frac{d}{dv} (k_s \rho) = k_s \rho d^2 \left(\frac{v}{K_s} \frac{dK_s}{dv} + \frac{v}{\rho} \frac{d\rho}{dy} \frac{dy}{ds} \frac{ds}{dv} - \frac{v}{M} \frac{dM}{dv} \right)$$

Strictly, we know nothing about dK_s/dv . However, the maximum value of $\frac{v}{K_D} \frac{dK_D}{dv}$ is at most about 5, since, for most v , $\frac{1}{K_D} \frac{dK_D}{dv}$ is far less than 0.005 and v is less than 2,000 for the M8 even when fired forward from a fast plane, while when $\frac{1}{K_D} \frac{dK_D}{dv}$ rises to its maximum value of something less than 0.005, v will be at the speed of sound, or about 1,100. So, for lack of more precise knowledge, we assume that the same holds for K_s , in other words, that $\frac{v}{K_s} \frac{dK_s}{dv}$ is at most 5.

In computing $\frac{v}{\rho} \frac{d\rho}{dy} \frac{dy}{ds} \frac{ds}{dv}$, we have fairly definite information.

$$\frac{1}{\rho} \frac{d\rho}{dy} = -0.0000316$$

[see the discussion following (II.4.20)].

$$\left| \frac{dy}{ds} \right| \leq 1$$

and, by (III.3.1),

$$v \frac{ds}{dv} = \frac{v^2}{v \, dv/ds} = \frac{v^2}{G} \text{ approx.}$$

As $v < 2,000$ and $G = 6,000$ are typical for the M8, we see that $\frac{v}{\rho} \frac{d\rho}{dy} \frac{dy}{ds} \frac{ds}{dv}$ is far less than unity.

To treat $\frac{v}{M} \frac{dM}{dv}$, we write approximately

$$M\dot{v} = T$$

by (III.3.1), so that

$$M\dot{v} = -v_{\text{B}}\dot{M}$$

by (I.1.4). So

$$M = -v_{\text{B}} \frac{dM}{dv}$$

$$-\frac{v}{M} \frac{dM}{dv} = \frac{v}{v_{\text{B}}}$$

As v_{B} is of the order of 7,000, we conclude that

$$\left| -\frac{v}{M} \frac{dM}{dv} \right| < 1$$

So

$$\left| d^2v \frac{d}{dv} (k_s \rho) \right| \leq 5 k_s \rho d^3 \\ = 0.011$$

Hence we can neglect $d^2v \frac{d}{dv} (k_s \rho)$.

We now substitute for certain occurrences of G in (III.3.13) by use of (III.3.1), and also we substitute for $d\theta/ds$ by use of (III.3.11). There results

$$\begin{aligned} v \frac{d^2\delta}{ds^2} + \frac{dv}{ds} \frac{d\delta}{ds} \left[2 + k_L \rho d^2 v \frac{ds}{dv} + \frac{g \sin \theta_a}{v} \frac{ds}{dv} + k_D \rho d^2 v \frac{ds}{dv} \right. \\ \left. + k_H \rho d^4 v \frac{ds}{dv} (1 + k_s \rho d^3) + k_J \frac{ds}{dv} (1 + k_s \rho d^3) \right] \\ + \delta \left[k_M \rho d^2 v + \frac{d^2v}{ds^2} - \frac{g \sin \theta_a}{v^2} \frac{dv}{ds} + k_D \rho d^2 \frac{dv}{ds} \right. \\ \left. + d^2v \frac{d}{ds} (k_D \rho) + d^2v \frac{d}{ds} (k_L \rho) + k_L \rho d^2 \frac{dv}{ds} + \frac{k_H \rho d^4 G}{v} + \frac{k_J G}{v^2} \right. \\ \left. + k_H \rho d^4 k_L \rho d^2 v + k_J k_L \rho d^2 \right] = \frac{G L}{v k^2} + k_M \rho d^3 v \delta_M + \frac{k_H \rho d^4 G \delta_T}{v} \\ + \frac{k_H \rho d^4 g \cos \theta_a}{v} + k_H \rho d^4 k_L \rho d^2 v \delta_L + \frac{k_J G \delta_T}{v^2} + \frac{k_J g \cos \theta_a}{v^2} \\ + k_J k_L \rho d^2 \delta_L + \delta_T \frac{d^2v}{ds^2} - \frac{\delta_T g \sin \theta_a}{v^2} \frac{dv}{ds} + \delta_T \frac{d}{ds} (k_D \rho d^2 v) \\ + \frac{G d\delta_T}{v ds} - \frac{g \cos \theta_a}{v^2} \frac{dv}{ds} + \frac{d}{ds} (k_L \rho d^2 v \delta_L) \end{aligned}$$

In this, we can neglect $k_s \rho d^3$. Also, since $k_H \rho d^4 v (k_L \rho d^2 + k_D \rho d^2)$ is negligible compared to $k_M \rho d^3 v$, we subtract it from the coefficient of δ . We wish to subtract $k_J (k_L \rho d^2 + k_D \rho d^2)$ also from the coefficient of δ , and so we wish to show that it is negligible. For $v \leq 100$, it is negligible compared to $k_J G/v^2$, since G is of the order of 6,000 for the M8, and for $v \geq 100$, it is negligible compared to $k_M \rho d^3 v$, since k_J is of the order of unity for the M8.

By (III.3.1), $\frac{g \sin \theta_a}{v} \frac{ds}{dv}$ is of the order of $\frac{g \sin \theta_a}{G}$. So it is probably negligible with respect to 2. The exception would be a low-acceleration rocket fired with θ_a near 90° . Actually, instead of neglecting $\frac{g \sin \theta_a}{v} \frac{ds}{dv}$, we will replace it by $-\frac{g \sin \theta_a}{v} \frac{ds}{dv}$. This calls for neglecting $2 \frac{g \sin \theta_a}{v} \frac{ds}{dv}$, but this is permissible for most rockets. Likewise, we

subtract

$$\frac{k_H \rho d^4 g \sin \theta_a}{v} + \frac{k_J g \sin \theta_a}{v^2}$$

from the coefficient of δ since it is negligible compared to

$$\frac{k_H \rho d^4 G}{v} + \frac{k_J G}{v^2}$$

We now wish to neglect the combination

$$d^2 v \frac{d}{ds} (k_D \rho) + d^2 v \frac{d}{ds} (k_L \rho)$$

It equals

$$\begin{aligned} \frac{1}{\rho} \frac{d\rho}{ds} (k_D \rho d^2 v + k_L \rho d^2 v) - \frac{1}{M} \frac{dM}{dv} v \frac{dv}{ds} (k_D \rho d^2 + k_L \rho d^2) \\ + \frac{1}{K_D} \frac{dK_D}{dv} v \frac{dv}{ds} k_D \rho d^2 + \frac{1}{K_L} \frac{dK_L}{dv} v \frac{dv}{ds} k_L \rho d^2 \end{aligned}$$

The first of these is negligible with respect to $k_M \rho d^2 v$. In the second, we put approximately

$$\begin{aligned} - \frac{1}{M} \frac{dM}{dv} &= \frac{1}{v_E} \\ v \frac{dv}{ds} &= G \end{aligned}$$

Then we see that this term is negligible with respect to $k_J G/v^2$ for $v \leq 100$, and with respect to $k_M \rho d^2 v$ for $v \geq 100$. For the other two terms, we have dK_D/dv and dK_L/dv both very small for $v \leq 800$, so that for $v \leq 800$, the terms are negligible with respect to $k_J G/v^2$ or $k_H \rho d^4 G/v$. For $v \geq 800$, dK_D/dv and dK_L/dv may become larger, but still

$$\left| \frac{1}{K_D} \frac{dK_D}{dv} \right| \leq 0.005$$

and so probably

$$\left| \frac{1}{K_L} \frac{dK_L}{dv} \right| \leq 0.005$$

also. Thus the two terms are negligible with respect to $k_M \rho d^2 v$, though just barely.

With the various changes that we have made in the coefficient of δ , it now takes the form

$$\begin{aligned} k_M \rho d^2 v + \frac{d^2 v}{ds^2} - \frac{g \sin \theta_a}{v^2} \frac{dv}{ds} + k_D \rho d^2 \frac{dv}{ds} + k_L \rho d^2 \frac{dv}{ds} + \frac{k_H \rho d^4 G}{v} \\ - \frac{k_H \rho d^4 g \sin \theta_a}{v} - k_H \rho d^4 k_D \rho d^2 v + \frac{k_J G}{v^2} - \frac{k_J g \sin \theta_a}{v^2} - k_J k_D \rho d^2 \end{aligned}$$

By (III.3.1), this simplifies to

$$k_M \rho d^2 v + \frac{d^2 v}{ds^2} - \frac{g \sin \theta_a}{v^2} \frac{dv}{ds} + k_D \rho d^2 \frac{dv}{ds} + k_L \rho d^2 \frac{dv}{ds} + k_H \rho d^4 \frac{dv}{ds} + \frac{k_J}{v} \frac{dv}{ds}$$

We are thus enabled to write our differential equation for δ in the form

$$\begin{aligned} \frac{d^2}{ds^2} (v\delta) + \frac{d}{ds} (v\delta) & \left(k_L \rho d^2 + k_D \rho d^2 + k_H \rho d^4 + \frac{k_J}{v} - \frac{g \sin \theta_a}{v^2} \right) \\ & + k_M \rho d^2 (v\delta) = \frac{G}{v} \frac{L}{k^2} + k_M \rho d^2 v \delta_M + \delta_T \left[\frac{k_H \rho d^4 G}{v} + \frac{k_J G}{v^2} + \frac{d^2 v}{ds^2} \right. \\ & \left. - \frac{g \sin \theta_a}{v^2} \frac{dv}{ds} + \frac{d}{ds} (k_D \rho d^2 v) \right] + \frac{G}{v} \frac{d\delta_T}{ds} + g \cos \theta_a \left(\frac{k_H \rho d^4}{v} + \frac{k_J}{v^2} - \frac{1}{v^2} \frac{dv}{ds} \right) \\ & + k_L \rho d^2 \delta_L (k_H \rho d^4 v + k_J) + \frac{d}{ds} (k_L \rho d^2 v \delta_L) \quad (\text{III.3.14}) \end{aligned}$$

Strictly speaking, this depends on y through the occurrence of ρ . However, the change of ρ during burning is usually of little consequence and is ignored. Alternatively one can use any given approximation for y , as for instance that determined from the basic solution of Sec. 1.

With the k 's known as functions of v , and hence of s , (III.3.14) is a differential equation in δ . In general, it can be solved only by some laborious method such as numerical integration (see Reference 1, Chap. IV or Reference 8) or solution in series. However, if $k_M \rho d^2$ has a reasonably small variation, then a much simpler means exists for obtaining solutions with any required degree of accuracy.

Let us define a constant σ so that $2\pi/\sigma$ is an approximate value for $\sqrt{k_M \rho d^2}$. This we can do only in case $k_M \rho d^2$ does not vary greatly. Then we introduce the dimensionless distance S , defined by

$$S = \frac{2\pi s}{\sigma}$$

and let a prime denote differentiation with respect to S . If we put

$$u = \sqrt{\frac{2\pi}{\sigma}} v \quad (\text{III.3.15})$$

$$h_D = \frac{\sigma}{2\pi} k_D \rho d^2 \quad (\text{III.3.16})$$

$$h_L = \frac{\sigma}{2\pi} k_L \rho d^2 \quad (\text{III.3.17})$$

$$h_H = \frac{\sigma}{2\pi} k_H \rho d^4 \quad (\text{III.3.18})$$

$$h_J = \sqrt{\frac{\sigma}{2\pi}} k_J \quad (\text{III.3.19})$$

then (III.3.14) reduces to

$$\begin{aligned}
 (u\delta)'' + (u\delta)' \left(h_D + h_L + h_H + \frac{h_J}{u} - \frac{g \sin \theta_a}{u^2} \right) \\
 + \left(\frac{\sigma^2}{4\pi^2} k_M \rho d^3 - 1 \right) (u\delta) + u\delta = \frac{G}{u} \frac{\sigma L}{2\pi k^2} + \frac{\sigma^2}{4\pi^2} k_M \rho d^3 u \delta_M + \delta_T \left(\frac{h_H G}{u} \right. \\
 \left. + \frac{h_J G}{u^2} + u'' - \frac{g \sin \theta_a u'}{u^2} + h_D u' \right) + \frac{G}{u} (\delta_T)' + g \cos \theta_a \left(\frac{h_H}{u} + \frac{h_J}{u^2} \right. \\
 \left. - \frac{u'}{u^2} \right) + h_L \delta_L (h_H u + h_J) + (h_L u \delta_L)' \quad \text{(III.3.20)}
 \end{aligned}$$

Note that this has the form

$$Z'' + P(S)Z' + R(S)Z + Z = Q(S) \quad \text{(III.3.21)}$$

where

$$\begin{aligned}
 Z &= u\delta \\
 P(S) &= h_D + h_L + h_H + \frac{h_J}{u} - \frac{g \sin \theta_a}{u^2} \\
 R(S) &= \frac{\sigma^2}{4\pi^2} k_M \rho d^3 - 1
 \end{aligned}$$

and $Q(S)$ is the entire right-hand side of (III.3.20). Define Z_0 as the solution of

$$Z''_0 + Z_0 = Q(S) \quad \text{(III.3.22)}$$

subject to the conditions that at $S = P$, $Z_0 = Z_p$, $Z'_0 = Z'_p$. Define Z_{n+1} as the solution of

$$Z''_{n+1} + Z_{n+1} = -P(S)Z'_n - R(S)Z_n \quad \text{(III.3.23)}$$

subject to the conditions that at $S = P$, $Z_{n+1} = Z'_{n+1} = 0$.

By (III.1.22) and (III.1.23) or (III.1.24), we can write explicit formulas (involving integrals) for each of Z_0, Z_1, Z_2, \dots . From (III.3.22) and (III.3.23), it follows that

$$\begin{aligned}
 (Z_0 + \dots + Z_{n+1})'' + P(S)(Z_0 + \dots + Z_n)' \\
 + R(S)(Z_0 + \dots + Z_n) + (Z_0 + \dots + Z_{n+1}) = Q(S) \quad \text{(III.3.24)}
 \end{aligned}$$

So if the sum

$$Z_\infty = Z_0 + Z_1 + Z_2 + \dots \quad \text{(III.3.25)}$$

exists (and is differentiable term by term), then by letting n go to infinity in (III.3.24) Z_∞ is seen to be a solution of (III.3.21).

Also, obviously, at $S = P$, $Z_\infty = Z_p$ and $Z'_\infty = Z'_p$, so that Z_∞ is the solution of (III.3.21) that satisfies the given boundary conditions.

By our assumption that $k_M \rho d^3$ is nearly constant, $R(S)$ is small. Also it turns out that $P(S)$ is small (unless u is near zero). Thus we see from (III.1.23) or (III.1.24) that Z_1 is small compared to Z_0 , Z_2 is small compared to Z_1 , and in general Z_{n+1} is small compared to Z_n . Hence (III.3.25) converges quite rapidly. In fact, Z_0 is usually considered a sufficiently good approximation for Z , and $Z_0 + Z_1$ is considered a very close approximation.

Z_0 is closely related to the basic solution of Sec. 1.

Having found an approximation to Z of the desired accuracy, we find δ from the relation

$$\delta = \frac{Z}{u} = \sqrt{\frac{\sigma}{2\pi}} \frac{Z}{v}$$

Given δ , we can find θ by integration from (III.3.11). Any remaining quantities that are desired can be found by (I.5.2) to (I.5.5).

4. Special Solutions for the Velocity

In this section we assume that ρ is constant, and that K_D is a function of v only, that is, if v is in ft/sec,

$K_D = 4.68 \times 10^{-5}i$	$0 \leq v \leq 790$
$K_D = 5.94 \times 10^{-8}vi$	$790 \leq v \leq 970$
$K_D = 6.34 \times 10^{-14}v^2i$	$970 \leq v \leq 1,230$
$K_D = 9.57 \times 10^{-8}vi$	$1,230 \leq v \leq 1,370$
$K_D = 1.32 \times 10^{-4}i$	$1,370 \leq v \leq 1,800$
$K_D = 1.25 \times 10^{-3}v^{-0.3}i$	$1,800 \leq v \leq 2,600$
$K_D = 4.06 \times 10^{-3}v^{-0.46}i$	$2,600 \leq v \leq 3,600$

(see Reference 7, page iv or Reference 1, page 28), where i is a constant depending on the shape of the rocket. The quantity i is called the "form factor." For certain poorly streamlined rockets, $i\rho$ at sea level is as great as 200 to 300. Good streamlining may bring $i\rho$ as low as 100.

CASE 1. The variation in G and M is negligible. Then $k_D \rho d^2 v^2$ is a constant times a power of v . So we derive from (III.3.1) the formulas

$$v = G - g \sin \theta_a - k_D \rho d^2 v^2$$

$$\int \frac{G dv}{G - g \sin \theta_a - k_D \rho d^2 v^2} = Gt$$

This can be integrated exactly to give t as a function of v . However, it is far more convenient and usually sufficiently accurate to make an approximate integration by writing

$$\frac{G dv}{G - g \sin \theta_a - k_D \rho d^2 v^2} \cong \left(1 + \frac{g \sin \theta_a}{G} + \frac{k_D \rho d^2 v^2}{G} \right) dv$$

For instance, let $G = 2,000$ ft/sec², burning time = $t_b = 0.45$ sec, $d = 0.375$ ft, $M = 35$ lb, $\theta_a = 0$, $i\rho = 200$. Then if the rocket is fired from rest,

$$\begin{aligned} 900 &= 2,000 t_b = \int_0^{v_b} \left[1 + \frac{K_D \rho d^2 v^2}{(2,000)(35)} \right] dv \\ &= \int_0^{790} (1 + 1.88 \times 10^{-8} v^2) dv + \int_{790}^{v_b} (1 + 2.39 \times 10^{-11} v^3) dv \\ &= v_b + 6.27 \times 10^{-9} (790)^3 + 5.98 \times 10^{-12} v_b^4 - 5.98 \times 10^{-12} (790)^4 \\ &= v_b + 5.98 \times 10^{-12} v_b^4 + 0.76 \end{aligned}$$

To find v_b , we then have to solve

$$v_b + 5.98 \times 10^{-12} v_b^4 = 899.24$$

So

$$v_b = 895.4 \text{ ft/sec}$$

In other words, the drag has reduced the velocity from its vacuum value of 900 to an aerodynamic value of 895.4, a reduction of less than 1 per cent. In this case it is pointless to consider the effect of drag.

CASE 2. The variation in G is negligible but not so for M . By (I.1.1),

$$M \dot{v} = -\dot{M} v_E$$

so that

$$\begin{aligned} \frac{dv}{v_E} &= -\frac{dM}{M} \\ v &= v_E \ln \frac{M_0}{M} \end{aligned}$$

where M_0 is the mass when $v = 0$. In this we are neglecting drag, gravity, and variation of v_E . However, this is a fairly reasonable approximation for many rockets. So

$$M = M_0 e^{-v/v_E}$$

Hence

$$\frac{k_D \rho d^2 v^2}{G} = \frac{K_D \rho d^2 v^2 e^{v/v_E}}{M_0 G}$$

So

$$Gt = \int \left(1 + \frac{g \sin \theta_a}{G} + \frac{k_D \rho d^2 v^2}{G} \right) dv$$

can be integrated, and we can get t as a function of v .

CASE 3. Variation of both G and M to be accounted for. We write

$$t = \int \left(\frac{1}{G} + \frac{g \sin \theta_s}{G^2} + \frac{K_D \rho d^2 v^2 e^{\sigma/v_s}}{M_0 G^2} \right) dv \quad (\text{III.4.1})$$

Clearly a good procedure is to approximate $1/G$ as a polynomial in v . If G is given as a function of v , this can be done by any of various methods of curve fitting. However, usually G is given as a function of t . In this case, we first write

$$v \cong \int G dt$$

Inverting this function, we get t as a function of v , and hence G as a function of v . Approximating $1/G$ by a polynomial in v and substituting into (III.4.1) enables us to get a more accurate determination of t as a function of v , hence a more accurate determination of G as a function of v , hence a more accurate determination of $1/G$ as a polynomial in v , etc.

5. The Basic Solution for Dispersion in Firing from Aircraft

The solution given by (III.1.6) is valid for any situation that meets the assumptions used in finding the solution. If care is taken to use the correct values of S and P , that solution therefore holds for firing from aircraft. However, in its present form, it conceals some information which is of value to designers of aircraft rockets. The purpose of this section is to change the form of the solution slightly so that it will display the desired information.

To start with, let us make some remarks about the properties of the functions G_1 , G_2 , G_3 , G_4 , and $-(G_1 + G_3)$, and about Figs. III.1.1 through III.1.5, which are plots of those functions. First, these functions depend only upon S and P , and not at all upon the acceleration G or the final velocity v_b , *except* as these quantities may be used in computing S and P . To illustrate what we mean, in the first example of Sec. 2, the values of these functions would still be the same if the acceleration were 24,000 ft/sec² and the burnt velocity 1,800 ft/sec, since the value of s at the end of burning would still be

$$\left[\frac{(1,800)^2}{2(24,000)} \right] = 67.5$$

the length of the launcher is unchanged, and σ is unchanged.

Second, the graphs in Figs. III.1.1 through III.1.5 give two essentially different kinds of information. If we pick out the curves that

correspond to the proper value of P and follow them as S changes, we have a picture of the behavior of θ as the rocket progresses through burning. If the rocket stopped burning at any particular point, the value of θ at this point is obviously θ_b . Therefore, the curves also show how θ_b varies with the value of S at the end of burning, or in terms of s , with the value of s at the end of burning. We call the value of s at the end of burning the "burning distance," for rockets fired from a stationary launcher, so that these pictures show how θ varies with the burning distance. It is often this type of information which the designer wants.

If the rocket is fired from an airplane, it is still true that these graphs show the behavior of θ during burning and how θ_b varies with the value of S or of s at the end of burning. But the designer cannot control the value of s at the end of burning, because that quantity depends upon the airplane's speed as well as upon the rocket. What he can control is the distance that the rocket would burn if the rocket were fired from the ground, which, if drag can be neglected, is the burning distance measured relative to the launcher. The information that the designer wants is the variation of θ_b with this quantity, which we shall call the "burning distance." The reader is cautioned that this usage may not be general; in discussing the burning distance of aircraft rockets, he should be very careful to specify what distance he means.

It is fairly simple to change the functions G_1 , G_2 , G_3 , G_4 , and $-(G_1 + G_3)$ to reveal their dependence upon the burning distance. Let v_a denote the velocity of the aircraft, V_b the burnt velocity of the rocket relative to the launcher, s' the burning distance relative to the launcher, and p' the length of the launching device. (More precisely, p' is the distance traveled by the rocket between firing and launching, relative to the aircraft.) Then, if G is the acceleration of the rocket

$$V_b^2 = 2Gs' \quad (\text{III.5.1})$$

The velocity at launching relative to the aircraft is $\sqrt{2Gp'}$, so the velocity relative to the air is $(v_a + \sqrt{2Gp'})$. The proper value of p is therefore

$$p = \frac{(v_a + \sqrt{2Gp'})^2}{2G} \quad (\text{III.5.2})$$

At the end of burning, the velocity relative to the air is $v_a + V_b$, so

$$s = \frac{(v_a + V_b)^2}{2G} \quad (\text{III.5.3})$$

For the next step we have two choices. We can hold the burnt velocity V_b constant, allowing G to vary with s' , or hold G constant, allowing V_b to vary with s' . It is usually more useful to know what happens with a constant V_b , allowing G and s' to vary, since this corresponds to the case where we have a fixed amount of propellant but vary the burning rate. So we choose that course. This means that we wish to eliminate G from the equations.

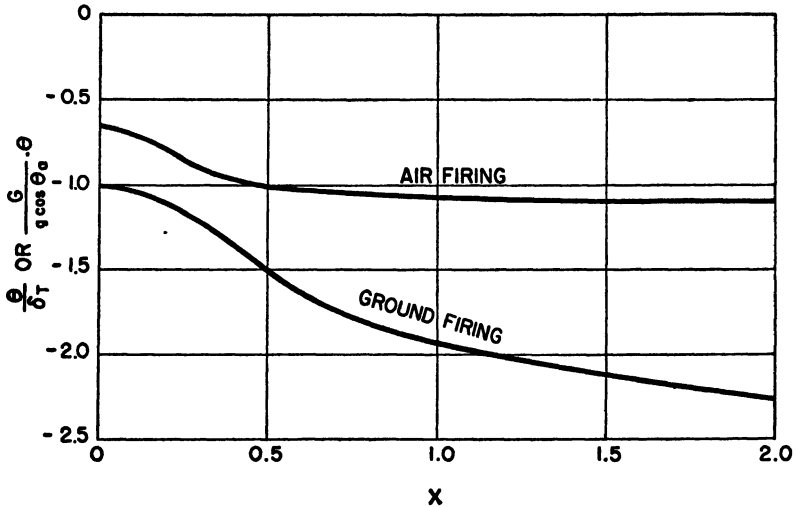

FIG. III.5.1.—Dispersion due to gravity or jet malalignment angle for air and ground firing from a zero-length launcher. For air firing, aircraft velocity is one-half of burnt velocity of rocket relative to aircraft.

$\delta\tau$ = jet malalignment angle.

G = rocket acceleration.

g = acceleration due to gravity.

θ_a = value of θ at the time of launching.

$x = S/2\pi$ [with S defined by (III.5.5)] = (burning distance relative to launcher)/(wave length of yaw).

We eliminate G by means of (III.5.1). If we solve that equation for $2G$ and substitute into (III.5.2) and (III.5.3), the result is

$$p = p' \left(1 + \frac{v_a}{V_b} \sqrt{\frac{s'}{p'}} \right)^2$$

$$s = s' \left(1 + \frac{v_a}{V_b} \right)^2$$

Thus the proper values of P and S are

$$P = \frac{2\pi p'}{\sigma} \left(1 + \frac{v_a}{V_b} \sqrt{\frac{s'}{p'}} \right)^2 \tag{III.5.4}$$

$$S = \frac{2\pi s'}{\sigma} \left(1 + \frac{v_a}{V_b} \right)^2 \tag{III.5.5}$$

The important new parameter is (v_a/V_b) , the ratio of the aircraft velocity to the burnt velocity relative to the aircraft.

If we consider G_1, G_2, G_3 , and G_4 as functions of (s'/σ) , (p'/σ) , and (v_a/V_b) , these functions, for fixed (p'/σ) and (v_a/V_b) , vary with (s'/σ) in quite different fashion from the way they varied with s/σ . Figures III.5.1 through III.5.4 give comparisons of G_1, G_2, G_3 , and $-(G_1 + G_3)$ for equal values of s'/σ and s/σ in the special case of $p' = 0$, for the

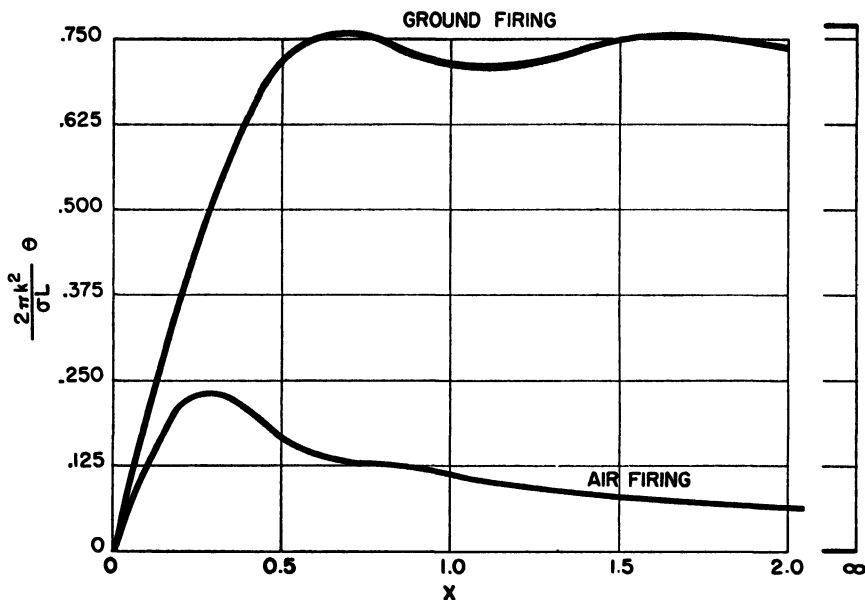

FIG. III.5.2.—Dispersion due to jet malalignment distance for air and ground firing from a zero-length launcher. For air firing, aircraft velocity is one-half of burnt velocity of rocket relative to aircraft.

k = radius of gyration about a transverse axis through the C.G.

σ = wave length of yaw.

L = jet malalignment distance.

$x = S/2\pi$ [with S defined by (III.5.5)] = (burning distance relative to launcher)/(wave length of yaw).

two cases $(v_a/V_b) = \frac{1}{2}$ and $(v_a/V_b) = 0$. That is, they compare values of these functions in air firing and ground firing, for the same burning distance relative to the launcher. Note carefully that though the ground-firing curves give the graph of θ against (s/σ) as well as the graph of θ_b against (s_b/σ) , the air-firing curves give only the graph of θ_b against (s'/σ) .

For any launcher length p' different from zero, these functions have qualitatively the same behavior. The following points summarize the principal features of these functions:

1. Those functions which had a finite limit (G_2, G_3 , and G_4) in

ground firing as (s/σ) approaches infinity now approach zero as (s'/σ) approaches infinity. In particular, G_2 , which describes the dispersion due to L , reaches a maximum at a relatively small value of (s'/σ) and then decreases monotonically to zero as the burning distance increases indefinitely.

2. The functions that had logarithmic behavior for large (s/σ) , that is, G_1 and $-(G_1 + G_2)$, now approach a limit as (s'/σ) approaches

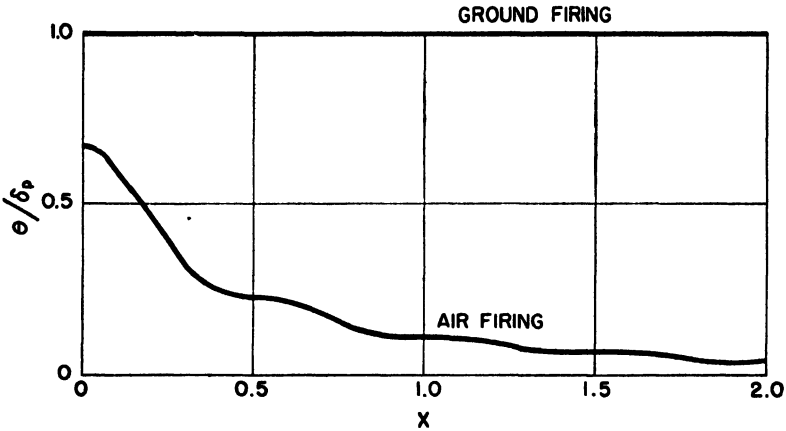

FIG. III.5.3.—Dispersion due to initial yaw for air and ground firing from a zero-length launcher. For air firing, aircraft velocity is one-half of burnt velocity of rocket relative to aircraft.

δ_p = angle of yaw at launching.

$x = S/2\pi$ [with S defined by (III.5.5)] = (burning distance relative to launcher)/(wave length of yaw).

infinity. To evaluate this limit, we note first that G_2 approaches zero. The asymptotic expression for G_1 is $\frac{1}{2}[ir(P) - ir(S)]$. As (s'/σ) increases without limit, S and P approach

$$P \rightarrow \left(\frac{2\pi}{\sigma}\right) \left(\frac{v_a}{V_b}\right)^2 s'$$

$$S \rightarrow \left(\frac{2\pi}{\sigma}\right) \left(1 + \frac{v_a}{V_b}\right)^2 s'$$

By (V.7.11), $ir(w)$ approaches $\ln w + \ln 4 + \gamma$ for large w , so that

$$G_1 \cong \frac{1}{2} (\ln P - \ln S) = \frac{1}{2} \ln \frac{P}{S}$$

But P/S approaches $(v_a/V_b)^2/[1 + (v_a/V_b)]^2$, so G_1 approaches

$$\ln \left[\frac{v_a}{(v_a + V_b)} \right]$$

For (v_a/V_b) equal to $\frac{1}{2}$, G_1 substantially attains its limit for $(s'/\sigma) = \frac{1}{2}$.

3. $G_1, G_2,$ and G_3 are less in magnitude for air firing than for ground firing, at the same values of (s'/σ) and (s/σ) . On the other hand, $-(G_1 + G_3)$ is greater for air firing at small values of s'/σ .

4. It is difficult to give a significant comparison of the term involving G_4 . We could discuss the behavior of G_4 , but this would not necessarily give a true picture of the behavior of θ . The behavior of θ depends upon the product $\phi'_p G_4$, and ϕ'_p may depend upon P .

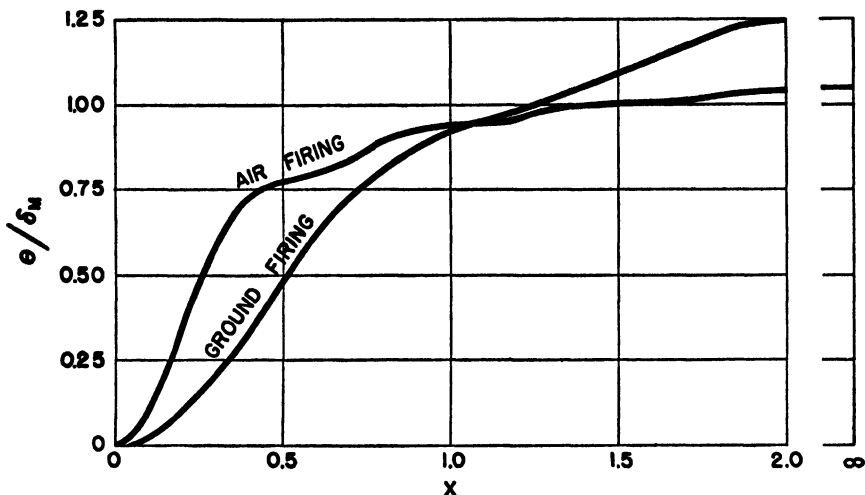

FIG. III.5.4.—Dispersion due to fin malalignment angle for air and ground firing from a zero-length launcher. For air firing, aircraft velocity is one-half of burnt velocity of rocket relative to aircraft.

δ_M = fin malalignment angle.

$x = S/2\pi$ [with S defined by (III.5.5)] = (burning distance relative to launcher)/(wave length of yaw).

In order to make any remarks about θ , it is necessary to know how the value of ϕ'_p arises. Hence we have given no graph for G_4 .

5. Similarly, one should not conclude that the part of θ due to gravity approaches a limit simply because G_1 does so. θ depends upon the product $(g \cos \theta_p/G)G_1$. As (s'/σ) increases without limit, G_1 approaches a limit, which is not zero, but G approaches zero. Therefore the magnitude of θ increases without limit.

6. The Basic Solution for Firing in a Vacuum

This solution ignores all the aerodynamic forces. Historically, this solution was probably the first to be obtained, but it has proved to be of little value in present rocket practice. The effects of the air at ordinary altitudes are so large that ignoring them does not even give the correct qualitative picture, except for rockets with a burning distance less than $\frac{1}{2}\sigma$. However, if rockets are fired from aircraft at

high altitudes, near-vacuum conditions prevail, so that this solution may have some future applications.

In a vacuum, σ becomes infinite, so that we could find the vacuum solution by letting σ approach infinity in the solution of Sec. 1. However, it is easier to remove the aerodynamic terms from the equations of motion and solve them afresh.

Since we want the basic solution, we also put the jet damping term equal to zero and neglect $Mg \sin \theta_a$ in comparison with the thrust. Then (I.5.18), (I.5.19), and (I.5.20) reduce to

$$v \frac{dv}{ds} = G \quad (\text{III.6.1})$$

$$v^2 \frac{d\theta}{ds} = G(\delta - \delta_r) - g \cos \theta_a \quad (\text{III.6.2})$$

$$v^2 \frac{d^2\phi}{ds^2} + v \frac{dv}{ds} \frac{d\phi}{ds} = \frac{GL}{k^2} \quad (\text{III.6.3})$$

From (III.6.1),

$$v^2 = 2Gs \quad (\text{III.6.4})$$

So, by (III.6.1) and (III.6.4), we can write (III.6.3) in the form

$$2s \frac{d^2\phi}{ds^2} + \frac{d\phi}{ds} = \frac{L}{k^2} \quad (\text{III.6.5})$$

By direct substitution, we verify that

$$\frac{d\phi}{ds} = \frac{\phi_p}{v_p} \sqrt{\frac{p}{s}} + \frac{L}{k^2} \left(1 - \sqrt{\frac{p}{s}} \right) \quad (\text{III.6.6})$$

is the solution of (III.6.5), which satisfies the condition that, at $s = p$,

$$\frac{d\phi}{ds} = \frac{d\phi}{dt} \div \frac{ds}{dt} = \frac{\phi_p}{v_p}$$

Now, by (III.6.4), write (III.6.2) in the form

$$2s \frac{d\theta}{ds} = \delta - \delta_r - \frac{g \cos \theta_a}{G} \quad (\text{III.6.7})$$

Since $\theta = \phi - \delta$, this gives

$$2s \frac{d\delta}{ds} + \delta = 2s \frac{d\phi}{ds} + \delta_r + \frac{g \cos \theta_a}{G}$$

By (III.6.6),

$$2s \frac{d\delta}{ds} + \delta = \frac{2\phi_p}{v_p} \sqrt{ps} + \frac{2L}{k^2} (s - \sqrt{ps}) + \delta_r + \frac{g \cos \theta_a}{G} \quad (\text{III.6.8})$$

By direct substitution, we verify that

$$\delta = \sqrt{\frac{p}{s}} \delta_p + \frac{\phi_p}{v_p} \sqrt{ps} \left(1 - \frac{p}{s}\right) + \frac{L}{3k^2} s \left(1 - \sqrt{\frac{p}{s}}\right)^2 \left(2 + \sqrt{\frac{p}{s}}\right) + \left(\delta_r + \frac{g \cos \theta_a}{G}\right) \left(1 - \sqrt{\frac{p}{s}}\right) \quad (\text{III.6.9})$$

is the solution of (III.6.8) which satisfies the condition $\delta = \delta_p$ at $s = p$.

We substitute this into (III.6.7) and find by integration that

$$\theta = \theta_p + \left(\delta_r + \frac{g \cos \theta_a}{G}\right) \left(\sqrt{\frac{p}{s}} - 1\right) + \frac{L(\sqrt{s} - \sqrt{p})^3}{3k^2 \sqrt{s}} + \delta_p \left(1 - \sqrt{\frac{p}{s}}\right) + \frac{\phi_p}{v_p} \sqrt{\frac{p}{s}} (\sqrt{s} - \sqrt{p})^2 \quad (\text{III.6.10})$$

Since

$$\phi'_p = \frac{\sigma \phi_p}{2\pi v_p}$$

for a rocket fired in air, we see by comparing (III.6.10) and (III.1.6) that the values of G_1 , G_2 , G_3 , and G_4 given in (III.1.7) to (III.1.10) for $s - p$ small are just the values for the vacuum solution.

7. Useful Mathematical Relations

From the definitions of F_1 to F_4 and G_1 to G_4 , we readily verify

$$F'_1 = -F_2 - \frac{F_1}{2S} + \frac{1}{2S} \quad (\text{III.7.1})$$

$$F'_2 = F_1 - \frac{F_2}{2S} \quad (\text{III.7.2})$$

$$F'_3 = -F_4 - \frac{F_3}{2S} \quad (\text{III.7.3})$$

$$F'_4 = F_3 - \frac{F_4}{2S} \quad (\text{III.7.4})$$

$$G'_1 = \frac{F_1}{2S} - \frac{1}{2S} \quad (\text{III.7.5})$$

$$G'_2 = \frac{F_2}{2S} \quad (\text{III.7.6})$$

$$G'_3 = \frac{F_3}{2S} \quad (\text{III.7.7})$$

$$G'_4 = \frac{F_4}{2S} \quad (\text{III.7.8})$$

$$\int_p^s F_1 dS = G_2 + F_2 \quad (\text{III.7.9})$$

$$\int_P^S F_2 dS = -G_1 - F_1 \quad (\text{III.7.10})$$

$$\int_P^S F_3 dS = G_4 + F_4 \quad (\text{III.7.11})$$

$$\int_P^S F_4 dS = -G_3 - F_3 + 1 \quad (\text{III.7.12})$$

$$\int_P^S \frac{F_1}{S} dS = 2G_1 + \ln \frac{S}{P} \quad (\text{III.7.13})$$

$$\int_P^S \frac{F_2}{S} dS = 2G_2 \quad (\text{III.7.14})$$

$$\int_P^S \frac{F_3}{S} dS = 2G_3 \quad (\text{III.7.15})$$

$$\int_P^S \frac{F_4}{S} dS = 2G_4 \quad (\text{III.7.16})$$

$$\int_P^S SF_1 dS = SF_2 + \frac{1}{2}G_1 + \frac{1}{2}F_1 \quad (\text{III.7.17})$$

$$\int_P^S SF_2 dS = -SF_1 + \frac{1}{2}G_2 + \frac{1}{2}F_2 + \frac{1}{2}(S - P) \quad (\text{III.7.18})$$

$$\int_P^S SF_3 dS = SF_4 + \frac{1}{2}G_3 + \frac{1}{2}F_3 - \frac{1}{2} \quad (\text{III.7.19})$$

$$\int_P^S SF_4 dS = -SF_3 + \frac{1}{2}G_4 + \frac{1}{2}F_4 - P \quad (\text{III.7.20})$$

$$\int_P^S \sqrt{S} F_1 dS = \sqrt{S} F_2 \quad (\text{III.7.21})$$

$$\int_P^S \sqrt{S} F_2 dS = -\sqrt{S} F_1 + \sqrt{S} - \sqrt{P} \quad (\text{III.7.22})$$

$$\int_P^S \sqrt{S} F_3 dS = \sqrt{S} F_4 \quad (\text{III.7.23})$$

$$\int_P^S \sqrt{S} F_4 dS = \sqrt{P} - \sqrt{S} F_3 \quad (\text{III.7.24})$$

If we integrate by parts judiciously in (III.7.17) to (III.7.24), we can derive formulas for $\int_P^S S^2 F_i dS$, $\int_P^S S \sqrt{S} F_i dS$, etc. For instance, if we write

$$\begin{aligned} \int_P^S SF_1 dS &= \frac{1}{2}S^2F_1 - \frac{1}{2} \int_P^S S^2F_1' dS \\ &= \frac{1}{2}S^2F_1 + \frac{1}{2} \int_P^S S^2F_2 dS + \frac{1}{2} \int_P^S SF_1 dS - \frac{1}{2} \int_P^S S dS \end{aligned}$$

then, by (III.7.17), we get a formula for $\int_P^S S^2F_2 dS$.

By direct substitution, one can verify that the solution Z of

$$Z'' + Z = Q(S)$$

which satisfies the conditions $Z = Z' = 0$ when $S = P$ is

$$Z = -\sqrt{S} F_1 + \frac{\sqrt{S}}{2P} F_4 \quad \text{when } Q(S) = \frac{1}{4S\sqrt{S}} \quad \text{(III.7.25)}$$

$$Z = \sqrt{S} F_2 \quad \text{when } Q(S) = \frac{1}{2\sqrt{S}} \quad \text{(III.7.26)}$$

$$Z = \sqrt{S} (1 - F_1 - F_2) \quad \text{when } Q(S) = \sqrt{S} \quad \text{(III.7.27)}$$

$$Z = S\sqrt{S} - P\sqrt{S} F_3 - \frac{3}{2}\sqrt{S} F_2 - \frac{3}{2}\sqrt{S} F_4 \quad \text{when } Q(S) = S\sqrt{S} \quad \text{(III.7.28)}$$

$$Z = \frac{\sqrt{S}}{4} (F_3 - 1 + F_1 + 2SF_2) \quad \text{when } Q(S) = \sqrt{S} F_1 \quad \text{(III.7.29)}$$

$$Z = \frac{\sqrt{S}}{4} (F_4 + 3F_2 - 2SF_1) \quad \text{when } Q(S) = \sqrt{S} F_2 \quad \text{(III.7.30)}$$

$$Z = \frac{S-P}{2} \sqrt{S} F_4 \quad \text{when } Q(S) = \sqrt{S} F_3 \quad \text{(III.7.31)}$$

$$Z = \frac{\sqrt{S}}{2} F_4 - \frac{(S-P)}{2} \sqrt{S} F_3 \quad \text{when } Q(S) = \sqrt{S} F_4 \quad \text{(III.7.32)}$$

$$\begin{aligned} Z = SF_2(S,P) + \frac{1}{2} \cos(S-P) - \frac{1}{2} \\ - \frac{1}{4} \int_P^S \frac{ra(x) \cos[S-x-rt(x)]}{\sqrt{x}} dx \\ + \frac{ra(P) \sqrt{S}}{2} \{ \sin[S-P+rt(P)]F_2(2S,2P) \\ + \cos[S-P+rt(P)]F_1(2S,2P) \} \\ \text{when } Q(S) = F_1(S,P) \end{aligned} \quad \text{(III.7.33)}$$

$$\begin{aligned} Z = -SF_1(S,P) + \frac{1}{2} \sin(S-P) \\ + \frac{1}{4} \int_P^S \frac{ra(x) \sin[S-x-rt(x)]}{\sqrt{x}} dx \\ - \frac{ra(P) \sqrt{S}}{2} \{ \cos[S-P+rt(P)]F_2(2S,2P) \\ - \sin[S-P+rt(P)]F_1(2S,2P) \} \\ \text{when } Q(S) = F_2(S,P) \end{aligned} \quad \text{(III.7.34)}$$

$$\begin{aligned} Z = (\sqrt{S} - \sqrt{P}) \sqrt{P} \sin(S-P) \\ + \sqrt{S} \sqrt{P} \cos(S-P)F_2(2S,2P) \\ - \sqrt{S} \sqrt{P} \sin(S-P)F_1(2S,2P) \\ \text{when } Q(S) = F_3(S,P) \end{aligned} \quad \text{(III.7.35)}$$

$$\begin{aligned}
 Z = & -(\sqrt{S} - \sqrt{P}) \sqrt{P} \cos(S - P) \\
 & + \sqrt{S} \sqrt{P} \sin(S - P) F_2(2S, 2P) \\
 & + \sqrt{S} \sqrt{P} \cos(S - P) F_1(2S, 2P) \\
 & \text{when } Q(S) = F_4(S, P) \quad (\text{III.7.36})
 \end{aligned}$$

$$\begin{aligned}
 Z = & \frac{1}{18}(-3 \sqrt{S} F_2 + 4S^3 F_1 + 4S^3 F_2 \\
 & + \sqrt{S} F_4 + 2P \sqrt{S} F_3 - 2S^3) \quad \text{when } Q(S) = S^3 F_1 \quad (\text{III.7.37})
 \end{aligned}$$

$$\begin{aligned}
 Z = & \frac{1}{18}(-5 \sqrt{S} F_1 + 4S^3 F_2 - 4S^3 F_1 + 5 \sqrt{S} \\
 & - 5 \sqrt{S} F_3 + 2P \sqrt{S} F_4) \quad \text{when } Q(S) = S^3 F_2 \quad (\text{III.7.38})
 \end{aligned}$$

$$\begin{aligned}
 Z = & \frac{1}{4}(S^3 F_4 + S^3 F_3 - P \sqrt{S} F_3 - P^2 \sqrt{S} F_4 \\
 & - \sqrt{S} F_4) \quad \text{when } Q(S) = S^3 F_3 \quad (\text{III.7.39})
 \end{aligned}$$

$$\begin{aligned}
 Z = & \frac{1}{4}(-S^3 F_3 + S^3 F_4 + P \sqrt{S} F_4 + P^2 \sqrt{S} F_3) \\
 & \text{when } Q(S) = S^3 F_4 \quad (\text{III.7.40})
 \end{aligned}$$

The solution Z of

$$Z'' + Z = 0$$

which satisfies the conditions $Z = 1$ and $Z' = 0$ when $S = P$ is $\sqrt{S} F_3 / \sqrt{P}$.

The solution Z of

$$Z'' + Z = 0$$

which satisfies the conditions $Z = 0$ and $Z' = 1$ when $S = P$ is $\sqrt{S} F_4 / \sqrt{P}$.

By combining the above results, one can solve

$$Z'' + Z = Q(S)$$

for quite a variety of $Q(S)$ and with any specified boundary conditions at $S = P$.

For any $Q(S)$ that cannot be handled directly by the above formulas, one can use (III.1.22) and (III.1.23) or (III.1.24). However, these are likely to lead to laborious integrations, and so one often resorts to various indirect methods. We shall illustrate two such methods.

Let it be required to find the Z such that

$$Z'' + Z = S^2 \sqrt{S} \quad (\text{III.7.41})$$

and $Z = Z' = 0$ when $S = P$.

Solution. Put $Z = S^2 \sqrt{S} + U$ and substitute into (III.7.41). This gives

$$U'' + U = -\frac{1}{4} S \sqrt{S}$$

Clearly, the boundary conditions on U are that $U = -P^2 \sqrt{P}$ and $U' = -\frac{1}{2} P \sqrt{P}$ when $S = P$. So by referring to (III.7.27) and

adding the appropriate terms to satisfy the boundary conditions, we get

$$U = \frac{1}{4} \sqrt{S} F_1 + \frac{1}{4} \sqrt{S} F_3 - \frac{1}{4} \sqrt{S} - P^2 \sqrt{S} F_3 - \frac{5}{2} P \sqrt{S} F_4$$

So the required Z to satisfy (III.7.41) is

$$Z = S^2 \sqrt{S} + \frac{1}{4} \sqrt{S} F_1 + \frac{1}{4} \sqrt{S} F_3 - \frac{1}{4} \sqrt{S} - P^2 \sqrt{S} F_3 - \frac{5}{2} P \sqrt{S} F_4 \quad (\text{III.7.42})$$

Let it be required to find the Z such that

$$Z'' + Z = S^2 \sqrt{S} F_1 \quad (\text{III.7.43})$$

and $Z = Z' = 0$ when $S = P$.

Solution. One would naturally put $Z = S^2 \sqrt{S} F_1 + U$ and substitute into (III.7.43), but this turns out to be futile. Instead one should put

$$Z = AS^i F_2 + U \quad (\text{III.7.44})$$

where A is a constant to be determined. Substituting (III.7.44) into (III.7.43) gives

$$U'' + U = (1 - 6A)S^i F_1 - 6AS^i F_2 - \frac{A}{2} S^i$$

Naturally one chooses $A = \frac{1}{6}$. So

$$U'' + U = -S^i F_2 - \frac{1}{12} S^i$$

The boundary conditions on U are $U = U' = 0$ when $S = P$. So, by (III.7.38) and (III.7.42),

$$U = -\frac{1}{16}(-5 \sqrt{S} F_1 + 4S^i F_2 - 4S^i F_1 + 5 \sqrt{S} - 5 \sqrt{S} F_3 + 2P \sqrt{S} F_4) - \frac{1}{48}(4S^i + 15 \sqrt{S} F_1 + 15 \sqrt{S} F_3 - 15 \sqrt{S} - 4P^2 \sqrt{S} F_3 - 10P \sqrt{S} F_4)$$

So the required Z to satisfy (III.7.43) is

$$Z = \frac{1}{12}(2S^i F_2 + 3S^i F_1 - 3S^i F_2 + P \sqrt{S} F_4 - S^i + P^2 \sqrt{S} F_3) \quad (\text{III.7.45})$$

A similar technique will give the values of Z when $Q(S) = S^i F_i$, $S^i F_i$, etc., as well as $Q(S) = S F_i$, $S^2 F_i$, etc. For convenience, we record that

$$Z = \frac{1}{24}(-4S^i F_1 + 6S^i F_2 + 6S^i F_1 - 21 \sqrt{S} F_2 + 2P^2 \sqrt{S} F_4 - 15 \sqrt{S} F_4 + 8S^i - 8P \sqrt{S} F_3) \quad \text{when } Q(S) = S^i F_2 \quad (\text{III.7.46})$$

$$Z = \frac{1}{12}(2S^i F_4 + 3S^i F_3 - 3S^i F_4 - 3P \sqrt{S} F_4 - 3P^2 \sqrt{S} F_3 - 2P^3 \sqrt{S} F_4) \quad \text{when } Q(S) = S^i F_3 \quad (\text{III.7.47})$$

$$Z = \frac{1}{12}(-2S^i F_3 + 3S^i F_4 + 3S^i F_3 - 3P \sqrt{S} F_3 + 3P^2 \sqrt{S} F_4 + 2P^3 \sqrt{S} F_3 - 3 \sqrt{S} F_4) \quad \text{when } Q(S) = S^i F_4 \quad (\text{III.7.48})$$

We list certain combinations of the above that may be useful on occasion.

$$Z = \frac{1}{2} \sqrt{S} (1 - F_1 - F_2 - 2PF_2) \quad \text{when } Q(S) = \frac{S - P}{2 \sqrt{S}} \quad (\text{III.7.49})$$

$$Z = \frac{1}{2} \sqrt{S} [2(S - P) - 3F_2 - 3F_4 + 2PF_1] \quad \text{when } Q(S) = (S - P) \sqrt{S} \quad (\text{III.7.50})$$

$$Z = \frac{1}{2} \sqrt{S} (2S - 4P + 4PF_1 - 3F_2 + 4P^2F_2 + 2PF_3 - 3F_4) \quad \text{when } Q(S) = \frac{(S - P)^2}{2 \sqrt{S}} \quad (\text{III.7.51})$$

$$Z = \frac{1}{2} \sqrt{S} [4(S - P)^2 + 15F_1 - 4P^2F_1 + 12PF_2 + 15F_3 + 2PF_4 - 15] \quad \text{when } Q(S) = (S - P)^2 \sqrt{S} \quad (\text{III.7.52})$$

$$Z = \frac{\sqrt{S}}{16} [4(S - P)^2F_2 + 4(S - P)F_1 - 4P^2F_2 - 3F_2 + F_4 - 2PF_3 - 2S + 4P] \quad \text{when } Q(S) = (S - P) \sqrt{S} F_1 \quad (\text{III.7.53})$$

$$Z = \frac{\sqrt{S}}{16} [-4(S - P)^2F_1 + 4(S - P)F_2 - 8PF_2 - 5F_1 + 5 - 5F_3 - 2PF_4 + 4P^2F_1] \quad \text{when } Q(S) = (S - P) \sqrt{S} F_2 \quad (\text{III.7.54})$$

$$Z = \frac{\sqrt{S}}{4} [(S - P)^2F_4 + (S - P)F_3 - F_4] \quad \text{when } Q(S) = (S - P) \sqrt{S} F_3 \quad (\text{III.7.55})$$

$$Z = \frac{\sqrt{S}}{4} [-(S - P)^2F_3 + (S - P)F_4] \quad \text{when } Q(S) = (S - P) \sqrt{S} F_4 \quad (\text{III.7.56})$$

$$Z = \frac{\sqrt{S}}{24} \left[4(S - P)^2F_2 + 6(S - P)^2F_1 - 6(S - P)F_2 + 3PF_2 + 4P^2F_2 + 2P^2F_3 - PF_4 - \frac{2(S - P)^3}{S} - \frac{2P^3}{S} \right] \quad \text{when } Q(S) = (S - P)^2 \sqrt{S} F_1 \quad (\text{III.7.57})$$

$$Z = \frac{\sqrt{S}}{24} [-4(S - P)^2F_1 + 6(S - P)^2F_2 + 6(S - P)F_1 - 4P^2F_1 + 21PF_1 - 21F_2 + 12P^2F_2 + 2P^2F_4 - 15F_4 + 8S + 7PF_3 - 15P] \quad \text{when } Q(S) = (S - P)^2 \sqrt{S} F_2 \quad (\text{III.7.58})$$

$$Z = \frac{\sqrt{S}}{12} [2(S - P)^2F_4 + 3(S - P)^2F_3 - 3(S - P)F_4] \quad \text{when } Q(S) = (S - P)^2 \sqrt{S} F_3 \quad (\text{III.7.59})$$

$$Z = \frac{\sqrt{S}}{12} [-2(S - P)^2F_3 + 3(S - P)^2F_4 + 3(S - P)F_3 - 3F_4] \quad \text{when } Q(S) = (S - P)^2 \sqrt{S} F_4 \quad (\text{III.7.60})$$

The various methods given above fail to take care of the case $Q(S) = F_i/\sqrt{S}$, which may arise. If we put

$$Ci(x) = \int_{-\infty}^x \frac{\cos t}{t} dt \tag{III.7.61}$$

$$Si(x) = \int_0^x \frac{\sin t}{t} dt \tag{III.7.62}$$

(see References 17, 18, and 19), then

$$Z = -\frac{1}{2} \int_P^S \frac{rj(x) \sin(S-x)}{x} dx + \frac{ra(P)}{4} \left\{ \cos[S+P-rt(P)][Ci(2S) - Ci(2P)] + \sin[S+P-rt(P)][Si(2S) - Si(2P)] - \cos[S-P + rt(P)] \ln \frac{S}{P} \right\} \quad \text{when } Q(S) = \frac{F_1}{\sqrt{S}} \tag{III.7.63}$$

$$Z = \frac{1}{2} \int_P^S \frac{rr(x) \sin(S-x)}{x} dx + \frac{ra(P)}{4} \left\{ \cos[S+P-rt(P)][Si(2S) - Si(2P)] - \sin[S+P-rt(P)][Ci(2S) - Ci(2P)] - \sin[S-P+rt(P)] \ln \frac{S}{P} \right\} \quad \text{when } Q(S) = \frac{F_2}{\sqrt{S}} \tag{III.7.64}$$

$$Z = \frac{\sqrt{P}}{2} \left\{ \sin(S-P) \ln \frac{S}{P} + \sin(S+P)[Ci(2S) - Ci(2P)] - \cos(S+P)[Si(2S) - Si(2P)] \right\} \quad \text{when } Q(S) = \frac{F_3}{\sqrt{S}} \tag{III.7.65}$$

$$Z = \frac{\sqrt{P}}{2} \left\{ -\cos(S-P) \ln \frac{S}{P} + \cos(S+P)[Ci(2S) - Ci(2P)] + \sin(S+P)[Si(2S) - Si(2P)] \right\} \quad \text{when } Q(S) = \frac{F_4}{\sqrt{S}} \tag{III.7.66}$$

8. The Effect of Lift, Cross-spin Force, and Damping Moment

In this section, we compute correction terms to be added to the basic solution of Sec. 1 to give the approximate effect of the lift, cross-spin force, and damping moment, which are neglected in obtaining the basic solution. We retain all other assumptions used in obtaining the basic solution and in addition assume that $k_{L\rho d^2}$, $k_{s\rho d^3}$, and $k_{H\rho d^4}$ are constant. Then (III.1.4) holds, which, by means of (III.1.16) and (III.3.15), we write in the form

$$u^2 = 2GS \tag{III.8.1}$$

Then (III.3.11) and (III.3.20) take the form

$$2S\theta' = \delta - \delta_T - \frac{g \cos \theta_a}{G} + 2h_L S \delta - 2h_L S \delta_L + 2h_S S \delta' \quad (\text{III.8.2})$$

$$\begin{aligned} (\sqrt{S} \delta)'' + (\sqrt{S} \delta)'(h_L + h_H) + \sqrt{S} \delta &= \frac{\sigma L}{2\pi k^2} \frac{1}{2\sqrt{S}} + \sqrt{S} \delta_M \\ &+ \left(\delta_T + \frac{g \cos \theta_a}{G} \right) \left(\frac{h_H}{2\sqrt{S}} - \frac{1}{4S\sqrt{S}} \right) \\ &+ h_L h_H \delta_L \sqrt{S} + \frac{h_L \delta_L}{2\sqrt{S}} \end{aligned} \quad (\text{III.8.3})$$

where

$$h_S = k_{sp} d^3 \quad (\text{III.8.4})$$

In (III.8.3), we shall neglect the term $h_L h_H \delta_L \sqrt{S}$ since it contains the product $h_L h_H$ of two small terms. In general, we shall ignore terms involving the product of two or more small terms.

By comparison of (III.8.3) with (III.1.17), we see that the δ which is the solution of (III.8.3) differs from the δ of the basic solution [namely, the δ which is the solution of (III.1.17)] by terms involving h_L or h_H as a factor. Hence in the term

$$(\sqrt{S} \delta)'(h_L + h_H) \quad (\text{III.8.5})$$

of (III.8.3), we may ignore the difference between our δ and the δ of the basic solution. So in (III.8.5) we may put

$$\begin{aligned} \sqrt{S} \delta &= \left(\delta_T + \frac{g \cos \theta_a}{G} \right) \sqrt{S} F_1 \\ &+ \frac{\sigma L}{2\pi k^2} \sqrt{S} F_2 + \delta_M \sqrt{S} (1 - F_1 - F_3) + \delta_p \sqrt{S} F_3 + \phi'_p \sqrt{S} F_4 \\ (\sqrt{S} \delta)' &= \left(\delta_T + \frac{g \cos \theta_a}{G} \right) \left(\frac{1}{2\sqrt{S}} - \sqrt{S} F_2 \right) \\ &+ \frac{\sigma L}{2\pi k^2} \sqrt{S} F_1 + \delta_M (\sqrt{S} F_2 + \sqrt{S} F_4) - \delta_p \sqrt{S} F_4 + \phi'_p \sqrt{S} F_3 \end{aligned}$$

Accordingly, we write (III.8.3) in the form

$$\begin{aligned} (\sqrt{S} \delta)'' + \sqrt{S} \delta &= \frac{\sigma L}{2\pi k^2} \left[\frac{1}{2\sqrt{S}} - (h_L + h_H) \sqrt{S} F_1 \right] \\ &+ \delta_M [\sqrt{S} - (h_L + h_H) (\sqrt{S} F_2 + \sqrt{S} F_4)] \\ &+ \left(\delta_T + \frac{g \cos \theta_a}{G} \right) \left[(h_L + h_H) \sqrt{S} F_2 - \frac{h_L}{2\sqrt{S}} - \frac{1}{4S\sqrt{S}} \right] \\ &+ \delta_p (h_L + h_H) \sqrt{S} F_4 - \phi'_p (h_L + h_H) \sqrt{S} F_3 + \frac{h_L \delta_L}{2\sqrt{S}} \end{aligned} \quad (\text{III.8.6})$$

One boundary condition for $\sqrt{S} \delta$ is that it shall equal $\sqrt{P} \delta_p$ when $S = P$. To find the second boundary condition, we put $S = P$ in (III.8.2), with the result

$$\sqrt{P} \theta'_p = \frac{\delta_p - \delta_T - (g \cos \theta_a/G)}{2 \sqrt{P}} + h_L \sqrt{P} \delta_p - h_L \sqrt{P} \delta_L + h_s \sqrt{P} \delta'_p$$

So, since $\theta = \phi - \delta$,

$$\sqrt{P} \delta'_p(1 + h_s) + \frac{\delta_p}{2 \sqrt{P}} = \sqrt{P} \phi'_p + \frac{\delta_T + (g \cos \theta_a/G)}{2 \sqrt{P}} - h_L \sqrt{P} \delta_p + h_L \sqrt{P} \delta_L$$

So, at $S = P$,

$$(\sqrt{S} \delta)' = \sqrt{P} \delta'_p + \frac{\delta_p}{2 \sqrt{P}} = \sqrt{P} \phi'_p(1 - h_s) + \frac{[\delta_T + (g \cos \theta_a/G)](1 - h_s)}{2 \sqrt{P}} - h_L \sqrt{P} \delta_p + h_L \sqrt{P} \delta_L + \frac{h_s \delta_p}{2 \sqrt{P}}$$

So, by (III.7.25) to (III.7.32),

$$\begin{aligned} \delta = & \left(\delta_T + \frac{g \cos \theta_a}{G} \right) \left[F_1 + \frac{h_H}{4} (F_4 + 3F_2 - 2SF_1) \right. \\ & \left. + \frac{h_L}{4} (F_4 - F_2 - 2SF_1) - \frac{h_s F_4}{2P} \right] + \frac{\sigma L}{2\pi k^2} \left[F_2 - \frac{h_L + h_H}{4} (F_3 - 1 \right. \\ & \left. + F_1 + 2SF_2) \right] + \delta_M \left\{ 1 - F_1 - F_3 - \frac{h_L + h_H}{4} [3F_4 + 3F_2 \right. \\ & \left. - 2SF_1 - 2(S - P)F_3] \right\} + \delta_p \left\{ F_3 + \frac{h_H}{2} [F_4 - (S - P)F_3] \right. \\ & \left. - \frac{h_L}{2} [F_4 + (S - P)F_3] + \frac{h_s}{2P} F_4 \right\} + \delta_L h_L (F_4 + F_2) \\ & + \phi'_p F_4 \left[1 - h_s - \frac{(h_L + h_H)(S - P)}{2} \right] \quad \text{(III.8.7)} \end{aligned}$$

Then, by (III.8.2),

$$\begin{aligned} \theta = \theta_p + \int_P^S \frac{\delta - \delta_T - (g \cos \theta_a/G)}{2S} dS \\ + h_L \int_P^S \delta dS - h_L \delta_L (S - P) + h_s \delta - h_s \delta_p \end{aligned}$$

By (III.8.7) and (III.7.9) to (III.7.16),

$$\begin{aligned}
\theta = \theta_p + \left(\delta_T + \frac{g \cos \theta_a}{G} \right) & \left[G_1 + \frac{h_H}{4} (G_4 + 2G_2 - F_2) \right. \\
+ \frac{h_L}{4} (G_4 + 2G_2 + 3F_2) - \frac{h_S}{2} \left(\frac{G_4}{P} - 2F_1 \right) & \left. \right] + \frac{\sigma L}{2\pi k^2} \left[G_2 - \frac{h_H}{4} (G_2 - F_1) \right. \\
- \frac{h_L}{4} (G_2 + 4G_1 + 3F_1) + h_S F_2 & \left. \right] + \delta_M \left[-G_1 - G_2 - \frac{h_H}{4} (2G_2 + 2G_4 \right. \\
- F_2 - F_4 + 2PG_2) - \frac{h_L}{4} (6G_2 + 6G_4 + 3F_2 + 3F_4 + 2PG_2 - 4S + 4P) & \\
+ h_S(1 - F_1 - F_2) & \left. \right] + \delta_p \left[G_3 + \frac{h_H}{4} (G_4 - F_4 + 2PG_2) + \frac{h_L}{4} (G_4 \right. \\
+ 3F_4 + 2PG_2) + \frac{h_S}{2} \left(\frac{G_4}{P} + 2F_2 - 2 \right) & \left. \right] + \delta_L h_L (G_4 + G_2 - S + P) \\
+ \phi'_p \left[G_4 - \frac{h_H}{4} (1 - G_2 - F_2 - 2PG_4) + \frac{h_L}{4} (3 - 3G_2 - 3F_2 \right. & \\
+ 2PG_4) - h_S(G_4 - F_4) & \left. \right] \quad (\text{III.8.8})
\end{aligned}$$

For large S , one can get a reasonable approximation by replacing the G 's by their asymptotic expansions and neglecting the F 's compared with unity or a G .

One notes that the expressions for δ and θ consist of the expressions for δ and θ given in the basic solution plus terms involving h_H , h_L , or h_S .

To get some estimate of the amount of these corrections, we took the second rocket in Sec. 2 above and assumed for it the same values of M , k^2 , K_H , K_L , and K_S as for the M8 rocket. Then the correction term turns out to be of the order of 20 per cent of the basic solution.

If it be desired to compute the effects of small variations in L , δ_M , or δ_T , we make all the assumptions for the basic solution, except that we do not assume L , δ_M , or δ_T constant. Then we approximate L , δ_M , and δ_T by polynomials in S . Then the resulting form of (III.3.20) can be readily solved for δ by the formulas of Sec. 7 above, which will also suffice for the subsequent integration required to compute θ . The reader can easily work out the details if desired.

9. The Effect of Jet Damping

In this section we consider correction terms to be added to the basic solution of Sec. 1 to give the approximate effect of jet damping, which is neglected in obtaining the basic solution. We retain all other assumptions used in obtaining the basic solution, and in addition assume that the jet damping coefficient is constant.

We have (III.8.1) holding again, so that (III.3.11) and (III.3.20) take the form

$$2S\theta' = \delta - \delta_r - \frac{g \cos \theta_a}{G} \tag{III.9.1}$$

$$(\sqrt{S} \delta)'' + (\sqrt{S} \delta)' \frac{h_J}{\sqrt{2GS}} + \sqrt{S} \delta = \frac{\sigma L}{2\pi k^2} \frac{1}{2\sqrt{S}} + \sqrt{S} \delta_M + \left(\delta_r + \frac{g \cos \theta_a}{G} \right) \left(\frac{h_J}{\sqrt{8GS}} - \frac{1}{4S\sqrt{S}} \right) \tag{III.9.2}$$

By reasoning analogous to that of the preceding section, we see that if $\Delta\delta$ is the difference between the corrected δ and the δ of the basic solution, then we have

$$(\sqrt{S} \Delta\delta)'' + \sqrt{S} \Delta\delta = \frac{h_J}{\sqrt{2G}} \left[-\frac{\sigma L}{2\pi k^2} F_1 + \left(\delta_r + \frac{g \cos \theta_a}{G} \right) F_2 - \delta_M(F_2 + F_4) + \delta_p F_4 - \phi_p' F_3 \right] \tag{III.9.3}$$

to solve under the conditions that $\sqrt{S} \Delta\delta$ and $(\sqrt{S} \Delta\delta)'$ are zero when $S = P$. By (III.7.33) to (III.7.36), we can write an expression for $\Delta\delta$. However, it involves

$$\int_P^S \frac{ra(x) \cos [S - x - rt(x)]}{\sqrt{x}} dx \tag{III.9.4}$$

and

$$\int_P^S \frac{ra(x) \sin [S - x - rt(x)]}{\sqrt{x}} dx \tag{III.9.5}$$

We notice that (III.9.4) and the negative of (III.9.5) are the real and imaginary parts of

$$e^{-is} \int_P^S \frac{rc(x)e^{ix}}{\sqrt{x}} dx$$

So it suffices to be able to compute

$$\int_0^w \frac{rc(x)e^{ix}}{\sqrt{x}} dx \tag{III.9.6}$$

In Appendix 5 we give tables and formulas for computing (III.9.6).

We now have a usable formula for $\Delta\delta$. However, when we try to perform the integration that leads to θ , we run into some more untabulated integrals. We did not bother to make tables for these also but computed θ by numerical integration for those few cases where values were desired. In particular, we computed the effect of jet

damping for the first rocket of Sec. 2 above, taking

$$\begin{aligned} r r_0 &= 2.25 \text{ ft}^2 \\ k^2 &= 0.70 \text{ ft}^2 \\ \dot{m} &= 35 \text{ lb/sec} \\ M &= 35 \text{ lb} \end{aligned}$$

The resulting correction was of the order of 10 per cent of the value given by the basic solution, the general effect being a decrease in the dispersion.

10. The Effect of Drag and Nonuniform Acceleration Due to the Rocket Thrust

In this section we consider correction terms to be added to the basic solution of Sec. 1 to give the approximate effect of the term $-k_D \rho d^2 v^2$ in (III.3.1) and also to indicate the effect of small variations of G . We retain the other assumptions of the basic solution and in addition assume that $k_D \rho d^2$ is constant.

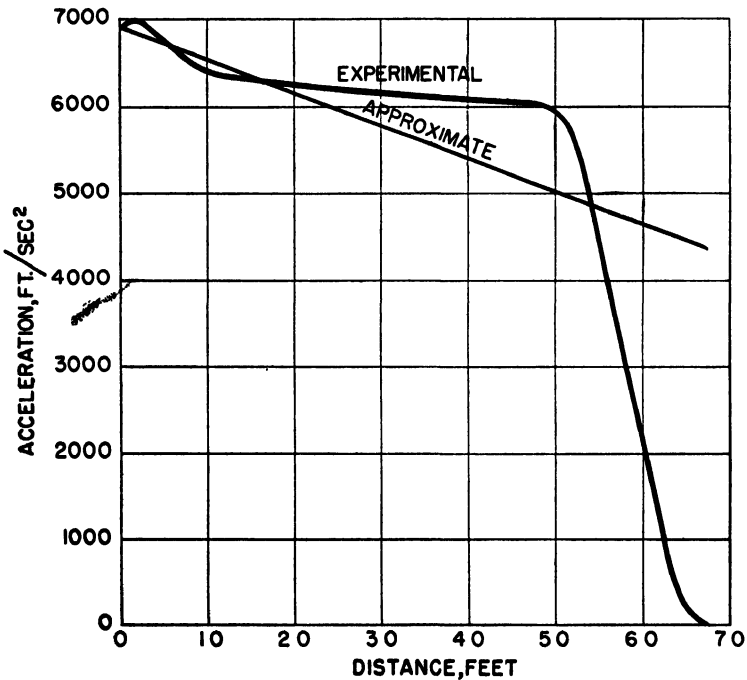

FIG. III.10.1.—Acceleration-distance curve of a rocket.

By use of (III.1.16), (III.3.15), and (III.3.16), we rewrite (III.3.1) in the form

$$uu' = G - h_D u^2$$

Let the variation of G be approximated by the equation

$$G = G_0(1 - h_g S) \quad (\text{III.10.1})$$

(See Fig. III.10.1 for example.) Then we have

$$(u^2)' + 2h_D u^2 = 2G_0(1 - h_g S)$$

$$u^2 = \frac{G_0}{2h_D^2} [2h_D + h_g - 2h_g h_D S - (2h_D + h_g)e^{-2h_D S}]$$

We expand the exponential and neglect powers of S beyond the second. Then

$$u^2 = 2G_0 S \left[1 - \left(h_D + \frac{h_g}{2} \right) S \right] \quad (\text{III.10.2})$$

This takes the place of (III.8.1).

We have then approximately

$$u = \sqrt{2G_0 S} \left[1 - \left(\frac{h_D}{2} + \frac{h_g}{4} \right) S \right]$$

$$\frac{1}{u} = \frac{1}{\sqrt{2G_0 S}} \left[1 + \left(\frac{h_D}{2} + \frac{h_g}{4} \right) S \right]$$

$$\frac{G}{u} = \frac{\sqrt{G_0}}{\sqrt{2S}} \left[1 + \left(\frac{h_D}{2} - \frac{3h_g}{4} \right) S \right]$$

$$u'' = -\frac{\sqrt{G_0}}{2S \sqrt{2S}} \left[1 + \left(\frac{3h_D}{2} + \frac{3h_g}{4} \right) S \right]$$

$$\frac{u'}{u^2} = \frac{1}{2S \sqrt{2G_0 S}} \left[1 - \left(\frac{h_D}{2} + \frac{h_g}{4} \right) S \right] \quad (\text{III.10.3})$$

If we substitute these into (III.3.20), then we can solve for δ by the formulas of Sec. 7 and the method of Sec. 8.

To get θ , we write (III.3.11) in the form

$$2S \left[1 - \left(h_D + \frac{h_g}{2} \right) S \right] \theta' = (1 - h_g S)(\delta - \delta_T) - \frac{g \cos \theta_a}{G_0}$$

So

$$2S \theta' = \left[1 + \left(h_D - \frac{h_g}{2} \right) S \right] (\delta - \delta_T) - \frac{g \cos \theta_a}{G_0} \left[1 + \left(h_D + \frac{h_g}{2} \right) S \right]$$

The necessary integrations to find θ can be performed by the formulas of Sec. 7.

The application of these formulas is rather intricate. Consider a case of constant G and take the effect of drag. In fact, let us take the second rocket in Sec. 2 and assume $h_D = 0.002$. As before, $v_p = 500$.

However, to find v_b , we integrate

$$\dot{v} = G - k_D \rho d^2 v^2$$

$$\int_{500}^{v_b} \frac{dv}{G - k_D \rho d^2 v^2} = \int_0^{0.30} dt = 0.30$$

Performing the integration and solving for v_b gives

$$v_b = 1,382$$

We now solve for p and s_b by (III.10.2), getting

$$P = 1.3124$$

$$S = 10.214$$

From here on, the procedure is quite direct and merely consists of substituting S and P into the appropriate formulas. In this case we find that the correction for drag will be less than 2 per cent of the value given by the basic solution. This discrepancy is wholly unimportant.

The procedure for the case of variable G is very similar and we do not discuss it. However, it is perhaps worth while to say a word about how one would obtain values for G_0 and h_G for an actual rocket. One way is to fire the rocket on a test stand equipped with a gauge that will record thrust as a function of time. Then

$$v = \int G dt$$

$$s = \int v dt$$

gives s (and hence S) as a function of t . Then we can obtain t as a function of S , and so G as a function of S . This is then approximated by a straight line, as in Fig. III.10.1.

Alternatively, one can fire the rocket in flight and measure distance as a function of time by taking motion pictures of the flight. Then two differentiations give acceleration as a function of time.

To illustrate the use of a typical set of data, let us take the first rocket of Sec. 2, this time with a nonconstant G . Let us assume that the following data have been obtained from an experimental shot:

Velocity at end of launcher = 290 ft/sec

Acceleration at end of launcher = 6,700 ft/sec²

Velocity 67 ft from end of launcher = 900 ft/sec, which is the burnt velocity.

It is important to realize that we cannot use the nominal launcher length, 6 ft, in computing P . The reason for this is that we know nothing about how velocity and acceleration vary before the rocket is launched. These quantities may vary in a quite different fashion while the rocket is in the launcher. Furthermore, the behavior of

the rocket is independent of events that occur before launching, provided that the proper boundary conditions at the end of the launcher are met.

To find h_a , G_0 , and P , we use the experimental data in the following manner:

The velocity is given by (III.10.3). Therefore, at the end of the launcher

$$290 = \sqrt{\frac{\sigma G_0}{\pi}} \sqrt{P} \left(1 - \frac{h_a}{4} P \right)$$

The acceleration is given by (III.10.1). At the end of the launcher

$$6,700 = G_0(1 - h_a P)$$

At a point 67 ft from the end of the launcher, $s = p + 67$ and

$$S = P + 67 \left(\frac{2\pi}{\sigma} \right) = P + 2.1049$$

Using the velocity at this point,

$$900 = \sqrt{\frac{\sigma G_0}{\pi}} \sqrt{P + 2.1049} \left[1 - \frac{h_a}{4} (P + 2.1049) \right]$$

We now have three equations to solve for G_0 , h_a , and P , knowing that $\sigma = 200$ ft. They are best solved by successive approximations, starting with the approximate value $G_0 = 6,700$ ft/sec². The solutions are

$$\begin{aligned} G_0 &= 6,936 \text{ ft/sec}^2 & h_a &= 0.1760 & P &= 0.1938 \\ S &= P + 2.1049 = 2.2987 \end{aligned}$$

From the value of P , as an aside, we compute that

$$p = \left(\frac{\sigma}{2\pi} \right) P = 6.17 \text{ ft}$$

which is different from the nominal launcher length.

Figure III.10.1 shows the acceleration-distance function that we have used in this example, that is, the function

$$G = 6,936 - (6,936)h_a S = 6,936 - (6,936)h_a \frac{2\pi}{\sigma} s$$

where $h_a = 0.1760$, and $\sigma = 200$ ft, from $s = 6.17$ ft to 73.17 ft. For comparison, a typical acceleration-distance curve is shown for a rocket with the same burnt velocity as our example, for distances both before and after launching. From the typical curve, we see that

the simple law which we have assumed does not represent the acceleration very well, nor is it likely that any simple law can be found which will do so. It may still be, of course, that other functions derived from the acceleration, and in particular, velocity and dispersion, are adequately represented.

We computed the dispersion on the basis of the values of G_0 and h_G given above and compared it with the dispersion for a constant acceleration rocket for which we had adjusted the acceleration to be 5,548 ft/sec² so as to give a velocity of $v_b = 900$ at the same value of s_b , namely, 73, that we used for the variable acceleration calculation. Otherwise the two rockets were like the first rocket in Sec. 2. The discrepancy was something over 20 per cent.

This is perhaps as good a place as any to say a few words about the choice of a time to be considered as the end of burning. When the propellant is consumed, then the pressure in the chamber falls off exponentially as the remaining gas is discharged. So there is no clear-cut "end of burning." The point at which the pressure has fallen to one-tenth its maximum value is commonly chosen as the end of burning. This choice is motivated by considerations of ease in measuring records of thrust against time from test-stand gauges and has no significance for the exterior ballistics of a rocket. In exterior ballistics, the appropriate time to be considered as the end of burning is determined by the condition that v shall equal v_b . This makes the choice of the end of burning depend slightly upon what degree of approximation we are using in computing v . However, since most of the dispersion arises early in burning, the exact choice of the end of burning is not very important.

The present section would be the proper place to consider the effect of the term $-g \sin \theta_a$ in (III.3.1), which is usually neglected. As a matter of fact, to find the effect of this term, we should have to compute additional integrals, since this term, like the jet damping term, involves us with integrals that cannot be evaluated by means of rocket functions. As it appears that this term is of little account, we simply have not bothered. (III.7.61) to (III.7.64) can be used to get a formal expression for δ .

11. The Effect of a Variable Wave Length of Yaw

More precisely, we consider the variation of $k_M \rho d^3$. Let this be represented by a polynomial function of S in the region to be considered and substitute this polynomial function for $k_M \rho d^3$ in (III.3.20), using a suitable (constant) value for σ . Then the resulting equation can be treated in the now familiar manner. Formulas for accomplishing

the necessary integrations are given in Sec. 7, and one can get explicit formulas for the corrections to δ and θ .

We estimated the effect of variable wave length of yaw for one particular rocket by a somewhat different method, in which $k_M \rho d^3$ was taken to be a polynomial in v and a power series solution of (III.3.20) was obtained. G was taken to be 6,000 ft/sec². Two extreme forms for the variation of $k_M \rho d^3$ were taken, namely,

$$\begin{aligned} k_M \rho d^3 &\text{ constant for } v \leq 800 \text{ ft/sec} \\ k_M \rho d^3 &= A_1 v \quad \text{for } v \geq 800 \text{ ft/sec} \\ k_M \rho d^3 &\text{ constant for } v \leq 800 \text{ ft/sec} \end{aligned} \quad (1)$$

$$k_M \rho d^3 = \frac{A_2}{v^3} - A_3 \text{ for } v \geq 800 \text{ ft/sec} \quad (2)$$

The constant for $v \leq 800$ was chosen to make $\sigma = 200$. A_1 , A_2 , and A_3 were chosen so that $k_M \rho d^3$ was a continuous function of v . At $v = 1,100$ ft/sec, the values of θ for either of the extreme cases were within 4 per cent of the value obtained with a constant value of $k_M \rho d^3$. We remark that this was perhaps not a very informative conclusion, since the variations in $k_M \rho d^3$ took place late in the burning, at which time most of the dispersion had already taken place.

12. The Dispersion of a Rocket with a Constant Angular Acceleration about Its Axis of Symmetry, in a Vacuum and in Air

All this chapter, since we obtained the basic solution and modified it to suit aircraft firing, has been devoted to studying small corrections to the basic solution. In the next few sections, we shall study events that alter the character of the solution profoundly.

One suggestion that is frequently made for the purpose of reducing rocket dispersion is to give the rocket a slow spin, or rotation about its axis of symmetry. This spin has a completely different purpose from the rapid spin that is frequently used with rockets and shells. Projectiles with high spin do not have fins but are stabilized by the spin. We are talking about a spin which is so low as to be worthless for purposes of stabilizing the projectile. Its purpose is rather to reverse frequently the direction in which thrust or fin malalignment tends to push the rocket. We still rely upon fins to give stability.

We can think of three ways to impart spin to a rocket. One way is to set the fin blades at an angle to the axis of symmetry, instead of parallel with it, so that fins on opposite sides of the rocket exert a couple tending to spin it. This method is of limited usefulness because it does not give the rocket spin during the early part of burning, where it is most important.

A second method is to give the rocket a spin before launching. This spin will damp out slowly because of fin action, but during the first part of burning it remains essentially constant. The reduction in dispersion caused by this method will be studied in the next section.

The third method is to use canted nozzles, or some other device which will cause the jet to exert a torque about the axis of symmetry and thus give the rocket an angular acceleration about its axis of symmetry. If the forward acceleration of the rocket is constant, this angular acceleration will be very nearly constant. In this section, we shall take the angular acceleration to be a constant.

The malalignments L , δ_T , and δ_M will not now be constants, as they have been in the previous work. Instead, we take for them the forms

$$L = \Lambda \exp(j\psi) \quad (\text{III.12.1})$$

$$\delta_T = \Delta_T \exp(j\psi) \quad (\text{III.12.2})$$

$$\delta_M = \Delta_M \exp(j\psi) \quad (\text{III.12.3})$$

Λ , Δ_T , and Δ_M are the values of L , δ_T , and δ_M when $s = S = 0$. ψ is the angle through which the rocket has turned about its axis of symmetry since $s = 0$.

As both the angular acceleration and the forward acceleration are constant, we can write the angular acceleration ($d^2\psi/dt^2$) as

$$\frac{d^2\psi}{dt^2} = \Gamma G$$

where Γ is some constant. At $t = 0$, we take $d\psi/dt$ and ψ to be zero, so, integrating $d^2\psi/dt^2$ twice,

$$\psi = \frac{1}{2}\Gamma G t^2$$

But $\frac{1}{2}Gt^2 = s$, the distance traveled, so

$$\psi = \Gamma s$$

We prefer to use S rather than s as the independent variable. Therefore

$$\psi = \Gamma s = \Gamma \frac{\sigma}{2\pi} S = \gamma S \quad (\text{III.12.4})$$

if we let $\Gamma = (2\pi/\sigma)\gamma$. Γ gives the number of radians turned per foot, while γ is the number of revolutions turned through while the rocket is traveling one wave length of yaw.

We are going to consider only the way in which the basic solution is modified by the presence of rotation, so we simplify (III.3.20) to

$$(u\delta)'' + u\delta = \frac{G}{u} \frac{\sigma L}{2\pi k^2} + u\delta_M - \frac{g \cos \theta_a u'}{u^2} + \delta_T u'' + \frac{G}{u} (\delta_T)' \quad (\text{III.12.5})$$

Clearly, those parts of the solution that depend upon gravity, δ_p , or ϕ'_p are unaffected by the spin. So we replace (III.12.5) by

$$(u\delta)'' + u\delta = \frac{G}{u} \frac{\sigma L}{2\pi k^2} + u\delta_M + \delta_T u'' + \frac{G}{u} (\delta_T)' \quad (\text{III.12.6})$$

with the boundary conditions that $\delta_p = \phi'_p = 0$ when $S = P$.

Using

$$u^2 = 2GS$$

and (III.12.1) to (III.12.4) in (III.12.6), we get

$$\begin{aligned} (\sqrt{S} \delta)'' + \sqrt{S} \delta &= \frac{\sigma \Lambda}{2\pi k^2} \frac{\exp(j\gamma S)}{2\sqrt{S}} \\ &+ \sqrt{S} \Delta_M \exp(j\gamma S) - \frac{\Delta_T}{4S\sqrt{S}} \exp(j\gamma S) \\ &+ \frac{\Delta_T}{2\sqrt{S}} j\gamma \exp(j\gamma S) \end{aligned} \quad (\text{III.12.7})$$

We simplify (III.3.11) similarly to

$$2S\theta' = \delta - \Delta_T \exp(j\gamma S) \quad (\text{III.12.8})$$

Hence

$$\begin{aligned} \theta &= \int_P^S \frac{\delta - \Delta_T \exp(j\gamma S)}{2S} dS \\ &= -\delta + \int_P^S \left[\delta' + \frac{\delta - \Delta_T \exp(j\gamma S)}{2S} \right] dS \end{aligned} \quad (\text{III.12.9})$$

The term θ_p does not occur in these because we are now considering only those effects which depend on spin.

To find θ , we must solve successively (III.12.7) and (III.12.9). Before undertaking this task, we are going to solve the corresponding equations for motion in a vacuum. We do this partly because the vacuum solution may be of some interest, but mainly because we want to use the vacuum solution in certain approximations that we

need later for the solution in air. The equations to be solved are (III.6.2) and (III.6.3), with $v = \sqrt{2Gs}$, $L = \Lambda \exp(j\Gamma s)$,

$$\delta_T = \Delta_T \exp(j\Gamma s)$$

and $\delta_M = \Delta_M \exp(j\Gamma s)$. Also we set $g = 0$. We take as boundary conditions that $\delta_p = 0$ and $(d\phi/ds)_p = 0$. Since $(d\phi/ds)$ equals $(d\theta/ds) + (d\delta/ds)$, and, by (III.6.2),

$$\left(\frac{d\theta}{ds}\right)_p = -\frac{\Delta_T}{2p} \exp(j\Gamma p)$$

the condition $(d\phi/ds)_p = 0$ is equivalent to

$$\left(\frac{d\delta}{ds}\right)_p = \frac{\Delta_T}{2p} \exp(j\Gamma p)$$

Following the routine of Sec. 6, we get

$$\begin{aligned} \delta = & \frac{\Lambda}{2k^2\Gamma} \left\{ \frac{1}{2\sqrt{\Gamma s}} [\overline{rc}(\Gamma p) \exp(j\Gamma p) - \overline{rc}(\Gamma s) \exp(j\Gamma s)] \right. \\ & + \frac{j}{\sqrt{s}} [\sqrt{s} \exp(j\Gamma s) - \sqrt{p} \exp(j\Gamma p)] \\ & \left. - j\sqrt{\Gamma s} [\overline{rc}(\Gamma s) \exp(j\Gamma s) - \overline{rc}(\Gamma p) \exp(j\Gamma p)] \right\} \\ & + j \frac{\Delta_T}{2\sqrt{\Gamma s}} [\overline{rc}(\Gamma p) \exp(j\Gamma p) - \overline{rc}(\Gamma s) \exp(j\Gamma s)] \end{aligned} \quad (\text{III.12.10})$$

Substituting this into (III.6.2),

$$\begin{aligned} \theta = & \frac{\Lambda}{2k^2\Gamma} \left\{ \frac{1}{2\sqrt{\Gamma s}} [\overline{rc}(\Gamma s) \exp(j\Gamma s) - \overline{rc}(\Gamma p) \exp(j\Gamma p)] \right. \\ & + j\sqrt{\frac{p}{s}} \exp(j\Gamma p) + j \exp(j\Gamma s) - 2j \exp(j\Gamma p) \\ & \left. - j\sqrt{\Gamma s} [\overline{rc}(\Gamma s) \exp(j\Gamma s) - \overline{rc}(\Gamma p) \exp(j\Gamma p)] \right\} \\ & + j \frac{\Delta_T}{2\sqrt{\Gamma s}} [\overline{rc}(\Gamma s) \exp(j\Gamma s) - \overline{rc}(\Gamma p) \exp(j\Gamma p)] \end{aligned} \quad (\text{III.12.11})$$

We are now ready to start with the solution in air, that is, with the solution of (III.12.7) and (III.12.9). (III.12.7) is subject to the conditions $\delta_p = 0$ and $\phi'_p = 0$. Setting $\phi'_p = 0$ is equivalent to

$$\delta'_p = \left(\frac{\Delta_T}{2P}\right) \exp(j\gamma P)$$

It is obvious from the form of these equations that each term in the right member of (III.12.7) makes a contribution to δ and θ which is independent of the other terms. We believe that it will make the development smoother if we obtain these individual contributions separately and then add them for the final result.

First, we consider the contribution of the term containing Λ . We see from (III.1.23) that

$$\sqrt{S}\delta = \frac{\sigma\Lambda}{8\pi k^2} \left\{ -j \exp(jS) \int_P^S \frac{1}{\sqrt{x}} \exp[j(\gamma-1)x] dx \right. \\ \left. + j \exp(-jS) \int_P^S \frac{1}{\sqrt{x}} \exp[j(\gamma+1)x] dx \right\}$$

Evaluating the integrals, dividing by \sqrt{S} , and using the boundary conditions that $\delta = \delta' = 0$,

$$\delta = \frac{\sigma\Lambda}{8\pi k^2} \left\{ \frac{1}{\sqrt{(\gamma+1)S}} \overline{rc}[(\gamma+1)S] \exp(j\gamma S) \right. \\ - \frac{1}{\sqrt{(\gamma-1)S}} \overline{rc}[(\gamma-1)S] \exp(j\gamma S) \\ + \frac{1}{\sqrt{(\gamma-1)S}} \overline{rc}[(\gamma-1)P] \exp[j(\gamma-1)P] \exp(jS) \\ \left. - \frac{1}{\sqrt{(\gamma+1)S}} \overline{rc}[(\gamma+1)P] \exp[j(\gamma+1)P] \exp(-jS) \right\} \quad (\text{III.12.12})$$

Differentiating with respect to S ,

$$\delta' = -\frac{\delta}{2S} + j \frac{\sigma\Lambda}{8\pi k^2} \left\{ -\frac{1}{\sqrt{(\gamma+1)S}} \overline{rc}[(\gamma+1)S] \exp(j\gamma S) \right. \\ - \frac{1}{\sqrt{(\gamma-1)S}} \overline{rc}[(\gamma-1)S] \exp(j\gamma S) \\ + \frac{1}{\sqrt{(\gamma-1)S}} \overline{rc}[(\gamma-1)P] \exp[j(\gamma-1)P] \exp(jS) \\ \left. + \frac{1}{\sqrt{(\gamma+1)S}} \overline{rc}[(\gamma+1)P] \exp[j(\gamma+1)P] \exp(-jS) \right\} \quad (\text{III.12.13})$$

If $\gamma \leq 1$, these expressions are troublesome, although they can be evaluated. The chief difficulty is that $rc[(\gamma-1)S]$ is not defined for $\gamma < 1$, so that it is necessary to avoid this form. However, $\gamma = 1$ is a slow rate of rotation, so slow that it is of little value in reducing dispersion, and is not likely to be used in practice. For this reason, we shall restrict the discussion to $\gamma > 1$.

By (III.12.9),

$$\theta = -\delta + \int_P^S \left(\delta' + \frac{\delta}{2S} \right) dS \quad (\text{III.12.14})$$

By inspection of $\delta' + (\delta/2S)$, we see that we know two of the four integrals required; the other two, namely,

$$\int_P^S \frac{1}{\sqrt{(\gamma + 1)S}} \bar{rc}[(\gamma + 1)S] \exp(j\gamma S) dS \quad (\text{III.12.15})$$

and

$$\int_P^S \frac{1}{\sqrt{(\gamma - 1)S}} \bar{rc}[(\gamma - 1)S] \exp(j\gamma S) dS \quad (\text{III.12.16})$$

have not been tabulated. Means of computing them are given in Reference 13. As they appear, they are functions of three variables, the lower limit P , the upper limit S , and the spin γ . By writing each integral as the difference of the integral from 0 to S and the integral from 0 to P , we need only to tabulate a function of two variables, namely, the upper limit S and γ .

For our purposes, we do not believe that it is necessary to tabulate these integrals, but we can resort to approximations. We feel that an approximation is allowable since we are dealing only with dispersion, and all that we require are an estimate of the size of the dispersion and an expression that will allow us to compare the dispersions of two rocket types having different characteristics.

We shall make two approximations that have to do with the size of S and P . S for many rockets, even when fired from a stationary launcher, is greater than π . There are examples, of course, for which this is not so. Most of the change in θ occurs for S less than π , and if S is greater than π , θ changes slowly as S increases. For this reason, we are going to take as our first approximation that S is infinite.

The values of P met in practice vary widely. For ground-fired rockets, P is usually of the order of 0 to 0.4. In air firing, P usually ranges from 1 to 3. We are going to make a second approximation which is rather poor for P greater than 1.5, but which improves in accuracy as P decreases. Many situations of practical interest cannot be handled by either approximation, but we shall indicate what to do about some of these situations. This second approximation consists of assuming that, for short distances, the vacuum solution is the same as the solution in air.

We shall first put in the approximation that $S = \infty$. By integrating (III.12.13) and using (III.12.14), we find θ . Setting $S = \infty$ in the result and using (V.4.21) and (V.4.22),

$$\begin{aligned}
 \theta(S = \infty) &= \frac{\sigma\Lambda}{8\pi k^2} \\
 &\left\{ -j \frac{1}{\sqrt{\gamma+1}} [\ln(\sqrt{\gamma+1}+1) - \ln(\sqrt{\gamma+1}-1)] \right. \\
 &\quad - j \frac{2}{\sqrt{\gamma-1}} \left(\frac{\pi}{2} - \tan^{-1} \sqrt{\gamma-1} \right) \\
 &\quad + j \int_0^P \frac{1}{\sqrt{(\gamma+1)S}} \overline{rc}[(\gamma+1)S] \exp(j\gamma S) dS \\
 &\quad + j \int_0^P \frac{1}{\sqrt{(\gamma-1)S}} \overline{rc}[(\gamma-1)S] \exp(j\gamma S) dS \\
 &\quad + \frac{1}{\sqrt{\gamma+1}} \overline{rc}[(\gamma+1)P] rc(P) \exp(j\gamma P) \\
 &\quad \left. - \frac{1}{\sqrt{\gamma-1}} \overline{rc}[(\gamma-1)P] \overline{rc}(P) \exp(j\gamma P) \right\} \tag{III.12.17}
 \end{aligned}$$

We still need a value to use for the two integrals that yet remain in this equation. To find an approximation for them, we take our solution for θ , and instead of setting $S = \infty$, we keep S finite and set $P = 0$. This result is

$$\begin{aligned}
 \theta(P = 0) &= \frac{\sigma\Lambda}{8\pi k^2} \\
 &\left(- \frac{1}{\sqrt{(\gamma+1)S}} \left\{ \overline{rc}[(\gamma+1)S] \exp(j\gamma S) - \sqrt{\frac{\pi}{2}} (1-j) \exp(-jS) \right\} \right. \\
 &\quad + \frac{1}{\sqrt{(\gamma-1)S}} \left\{ \overline{rc}[(\gamma-1)S] \exp(j\gamma S) - \sqrt{\frac{\pi}{2}} (1-j) \exp(jS) \right\} \\
 &\quad - j \int_0^S \frac{1}{\sqrt{(\gamma+1)S}} \overline{rc}[(\gamma+1)S] \exp(j\gamma S) dS \\
 &\quad - j \int_0^S \frac{1}{\sqrt{(\gamma-1)S}} \overline{rc}[(\gamma-1)S] \exp(j\gamma S) dS \\
 &\quad + \sqrt{\frac{\pi}{2}} \frac{1-j}{\sqrt{\gamma-1}} \left[\overline{rc}(S) \exp(jS) - \sqrt{\frac{\pi}{2}} (1-j) \right] \\
 &\quad \left. - \sqrt{\frac{\pi}{2}} \frac{1-j}{\sqrt{\gamma+1}} \left[rc(S) \exp(-jS) - \sqrt{\frac{\pi}{2}} (1+j) \right] \right) \tag{III.12.18}
 \end{aligned}$$

The vacuum solution for $p = 0$ is, from (III.12.11),

$$\begin{aligned}
 \theta(p = 0) &= \frac{\Lambda}{2k^2\Gamma} \left\{ \frac{1}{2\sqrt{\Gamma s}} \left[\overline{rc}(\Gamma s) \exp(j\Gamma s) \right. \right. \\
 &\quad \left. \left. - \sqrt{\frac{\pi}{2}} (1-j) \right] (1 - 2j\Gamma s) + j \exp(j\Gamma s) - 2j \right\}
 \end{aligned}$$

To find an approximation of the integrals that we need in (III.12.17), for small values of the upper limit, we equate the vacuum solution for θ to the value given by (III.12.18). Before doing this, we must put the vacuum solution in terms of S and γ rather than s and Γ . The relations are that $s = \sigma S/2\pi$ and $\Gamma = 2\pi\gamma/\sigma$. In terms of S and γ , the vacuum solution is

$$\theta(P = 0) = \frac{\sigma\Lambda}{8\pi k^2\gamma} \left\{ \frac{1}{\sqrt{\gamma S}} (1 - 2j\gamma S) \left[\overline{rc}(\gamma S) \exp(j\gamma S) - \sqrt{\frac{\pi}{2}} (1 - j) \right] + 2j \exp(j\gamma S) - 4j \right\} \quad (\text{III.12.19})$$

We now find the approximation needed by equating (III.12.18) and (III.12.19). When we do this, the limits on the integrals are 0 to S , but the result is equally valid if we replace the upper limit S by P and change S to P in all the other appropriate places. We find our final expression for θ by substituting this approximation into (III.12.17):

$$\begin{aligned} \theta = & \frac{\sigma\Lambda}{8\pi k^2} \left(\frac{\pi}{\sqrt{\gamma+1}} + j \left[\frac{2}{\sqrt{\gamma-1}} \tan^{-1} \sqrt{\gamma-1} \right. \right. \\ & \left. \left. - \frac{1}{\sqrt{\gamma+1}} \ln(\sqrt{\gamma+1}+1) + \frac{1}{\sqrt{\gamma+1}} \ln(\sqrt{\gamma+1}-1) \right] \right) \\ & - \frac{1}{\gamma} \left[(1 - 2j\gamma P) \frac{1}{\sqrt{\gamma P}} \overline{rc}(\gamma P) \exp(j\gamma P) \right. \\ & \left. - (1 - 2j\gamma P) \frac{1}{\sqrt{\gamma P}} \sqrt{\frac{\pi}{2}} (1 - j) + 2j \exp(j\gamma P) - 4j \right] \\ & - \frac{1}{\sqrt{(\gamma+1)P}} \left\{ \overline{rc}[(\gamma+1)P] \exp(j\gamma P) \right. \\ & \left. - \sqrt{\frac{\pi}{2}} (1 - j) \exp(-jP) \right\} [1 - \sqrt{P} \overline{rc}(P)] \\ & + \frac{1}{\sqrt{(\gamma-1)P}} \left\{ \overline{rc}[(\gamma-1)P] \exp(j\gamma P) \right. \\ & \left. - \sqrt{\frac{\pi}{2}} (1 - j) \exp(jP) \right\} [1 - \sqrt{P} \overline{rc}(P)] \quad (\text{III.12.20}) \end{aligned}$$

The procedure for finding the contributions to θ from δ_T and δ_M is similar to the procedure just followed. We shall merely give the results, mentioning none of the details except that, in a vacuum, the contribution from δ_M is zero.

$$\begin{aligned} \theta = \frac{\Delta r}{4} & \left(-\frac{1}{\sqrt{\gamma+1}} [\ln(\sqrt{\gamma+1}+1) - \ln(\sqrt{\gamma+1}-1)] \right. \\ & - \frac{2}{\sqrt{\gamma-1}} \tan^{-1} \sqrt{\gamma-1} - j \frac{\pi}{\sqrt{\gamma+1}} \\ & + j \frac{1}{\sqrt{(\gamma+1)P}} \left\{ \overline{rc}[(\gamma+1)P] \exp(j\gamma P) \right. \\ & - \left. \sqrt{\frac{\pi}{2}} (1-j) \exp(-jP) \right\} [1 - \sqrt{P} rc(P)] \\ & + j \frac{1}{\sqrt{(\gamma-1)P}} \left\{ \overline{rc}[(\gamma-1)P] \exp(j\gamma P) \right. \\ & - \left. \sqrt{\frac{\pi}{2}} (1-j) \exp(jP) \right\} [1 - \sqrt{P} \overline{rc}(P)] \\ & \left. - j \frac{2}{\sqrt{\gamma P}} \left[\overline{rc}(\gamma P) \exp(j\gamma P) - \sqrt{\frac{\pi}{2}} (1-j) \right] \right) \quad \text{(III.12.21)} \end{aligned}$$

$$\begin{aligned} \theta = \frac{\Delta x}{4} & \left((\gamma+1)^{-1} [\ln(\sqrt{\gamma+1}+1) \right. \\ & - \ln(\sqrt{\gamma+1}-1)] - 2(\gamma-1)^{-1} \tan^{-1} \sqrt{\gamma-1} \\ & + \left[\frac{4}{\gamma^2-1} + j\pi(\gamma+1)^{-1} \right] \\ & - [1 - \sqrt{P} rc(P)] \left\{ 2(\gamma+1)^{-1} \exp(j\gamma P) \right. \\ & + j(\gamma+1)^{-1} \frac{1}{\sqrt{P}} \overline{rc}[(\gamma+1)P] \exp(j\gamma P) \\ & - j(\gamma+1)^{-1} \frac{1}{\sqrt{P}} \sqrt{\frac{\pi}{2}} (1-j) \exp(-jP) \left. \right\} \\ & + [1 - \sqrt{P} \overline{rc}(P)] \left\{ 2(\gamma-1)^{-1} \exp(j\gamma P) \right. \\ & + j(\gamma-1)^{-1} \frac{1}{\sqrt{P}} \overline{rc}[(\gamma-1)P] \exp(j\gamma P) \\ & \left. - j(\gamma-1)^{-1} \frac{1}{\sqrt{P}} \sqrt{\frac{\pi}{2}} (1-j) \exp(jP) \right\} \right) \quad \text{(III.12.22)} \end{aligned}$$

As a test of the validity of our assumptions, we have computed the real parts of the right sides of (III.12.20), (III.12.21), and (III.12.22) by numerical integration of $(\delta/2S) - (\Delta r/2S) \exp(j\gamma S)$, for $P = 0$. The values of θ are plotted as a function of $S/2\pi = s/\sigma$, in Figs. III.12.1, III.12.2, and III.12.3. On Figs. III.12.1 and III.12.2 at $S = \infty$ is given the value computed from (III.12.20) and (III.12.21).

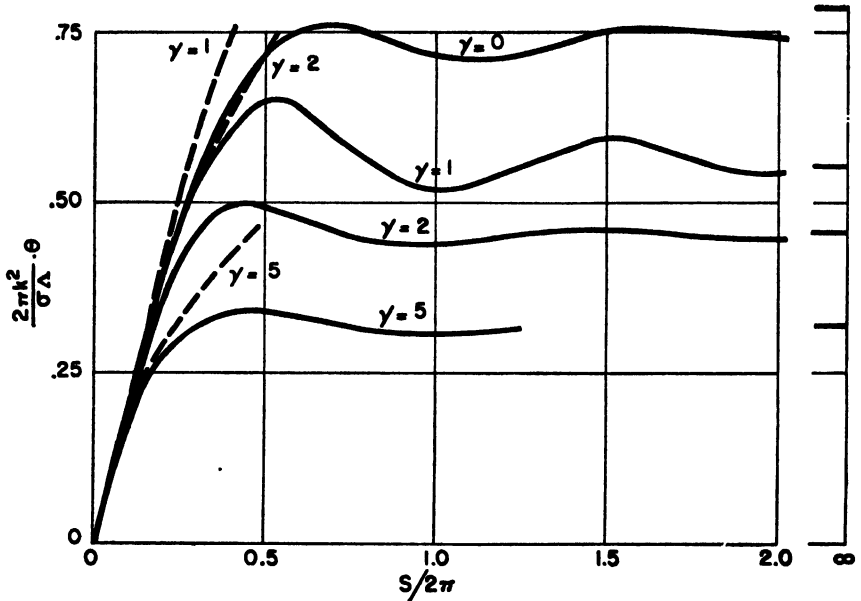

FIG. III.12.1.—Dispersion due to jet misalignment distance for a slowly spinning rocket launched from a zero-length launcher. Dashed lines give vacuum solution.
 k = radius of gyration about a transverse axis through the C.G.
 σ = wave length of yaw.
 Δ = jet misalignment distance.
 γ = number of revolutions per wave length of yaw.

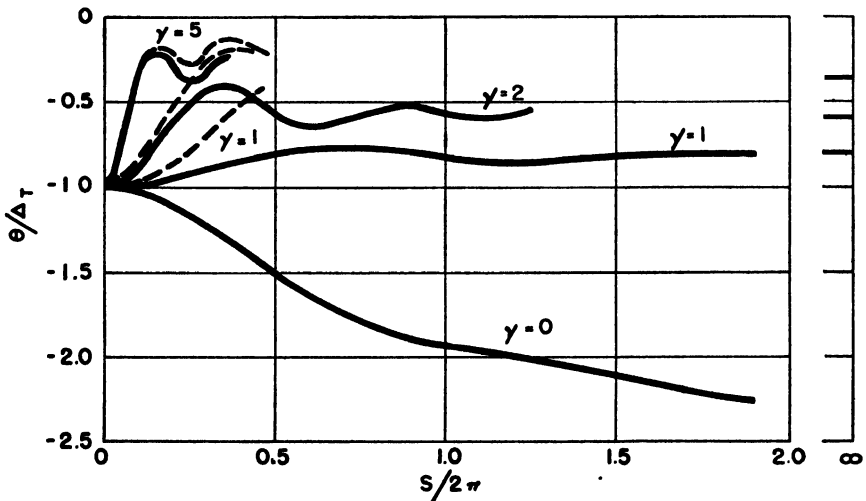

FIG. III.12.2.—Dispersion due to jet misalignment angle for a slowly spinning rocket launched from a zero-length launcher. Dashed lines give vacuum solution.
 $\Delta\tau$ = jet misalignment angle.
 γ = number of revolutions per wave length of yaw.

In these two figures θ is represented adequately by the value for $S = \infty$ for the range $s/\sigma > 0.5$, or $S > \pi$.

Turning to Fig. III.12.3, we see that when $\gamma = 1$, θ oscillates too violently over all the range of s/σ plotted to be represented by a single value. For $\gamma = 2$ or greater, θ is represented fairly well by the value from (III.12.22); in fact, θ is so small for $\gamma \geq 2$ that we are justified in saying that fin malalignment causes no significant dispersion.

From these figures, we feel that setting $S = \infty$ is a reasonable approximation.

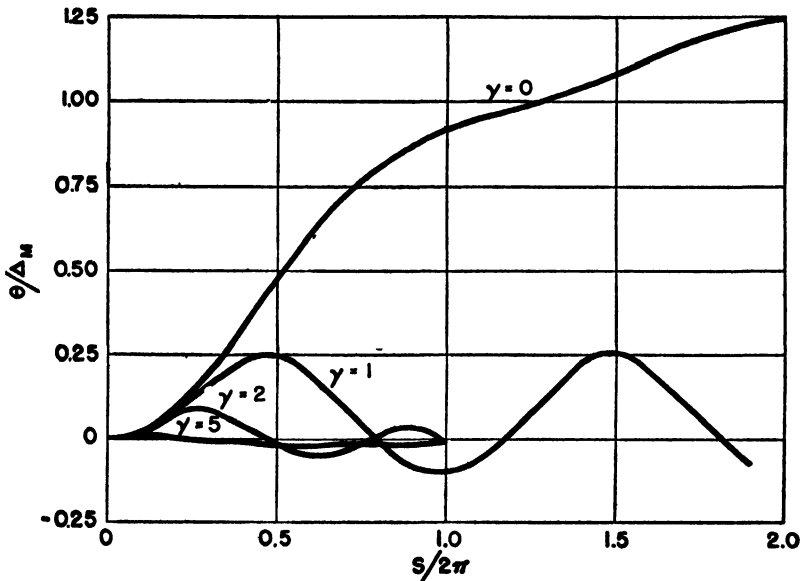

FIG. III.12.3.—Dispersion due to fin malalignment angle for a slowly spinning rocket launched from a zero-length launcher.
 Δ_M = fin malalignment angle.
 γ = number of revolutions per wave length of yaw.

As a test of our other assumption, we have plotted the vacuum solutions for θ for $p = 0$ in Figs. III.12.1 and III.12.2. At $S = 1$, or $s/\sigma = 0.16$, approximately, the vacuum solution begins to depart appreciably from the solution in air. At $s/\sigma = 0.25$, or $S = 1.5$, approximately, the discrepancy is probably becoming serious.

In Figs. III.12.4 and III.12.5 we have plotted the magnitudes of θ for $S = \infty$ as functions of γ , for various values of P , using (III.12.20) and (III.12.21). Those portions of the curves lying between $\gamma = 0$ and $\gamma = 1$ were not computed. For large γ , θ varies inversely with the square root of γ .

If S is so small that we cannot satisfactorily assume $S = \infty$, S may be small enough that we can use the vacuum solution. There is an intermediate range of S , roughly between $S = 1.5$ and $S = 3$,

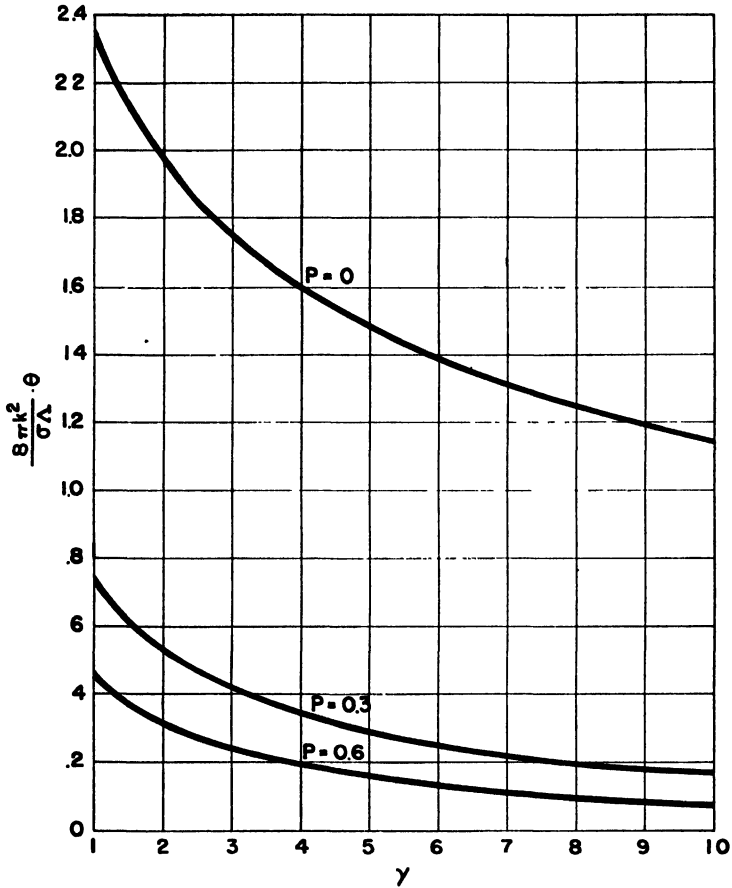

FIG. III.12.4.—Dispersion due to jet malalignment distance for a slowly spinning rocket with large burning distance.

- k = radius of gyration about a transverse axis through the C.G.
- σ = wave length of yaw.
- Λ = jet malalignment distance.
- γ = number of revolutions per wave length of yaw.

for which neither type of approximation is satisfactory. We can perhaps handle this intermediate range by plotting θ from the vacuum approximation as a function of S , and the horizontal lines corresponding to the value for $S = \infty$, and joining these two by a smooth curve.

If P is so large that the procedure of using the vacuum trajectory is not valid, we must turn to the methods outlined in Reference 13

for evaluating the integrals. We suspect, though, that if P is this large and γ is large, then these integrals are small compared with other terms in the equation. We base this suspicion primarily upon

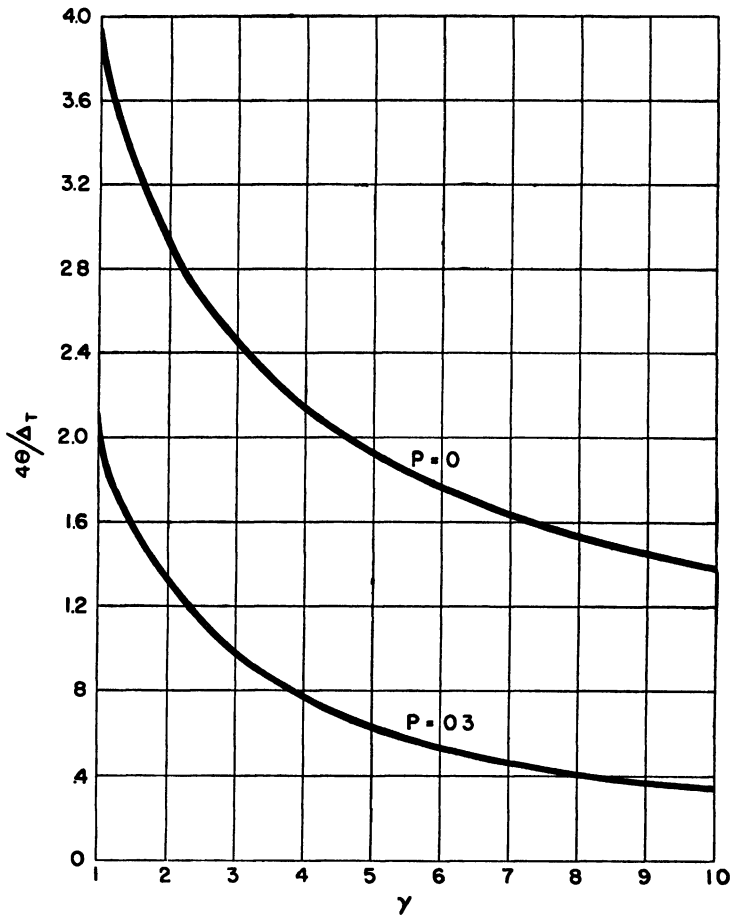

FIG. III.12.5.—Dispersion due to jet malalignment angle for a slowly spinning rocket with large burning distance.

$\Delta\tau$ = jet malalignment angle.

γ = number of revolutions per wave length of yaw.

the fact that, for large γ , these integrals vary as $1/\gamma$, whereas the other terms in (III.12.20) and (III.12.21) vary as $1/\sqrt{\gamma}$.

13. The Dispersion of a Rocket with a Constant Angular Velocity about Its Axis of Symmetry, in a Vacuum and in Air

If, by some means, the rocket is given a constant angular velocity of Ω rad/sec about its axis of symmetry at the time of launching, the

angle ψ is given by

$$\psi = \Omega t$$

To express this in terms of S , we have that $s = \frac{1}{2}Gt^2$, whence

$$t = \sqrt{\frac{2s}{G}} = \sqrt{\frac{\sigma}{\pi G}} \sqrt{S}$$

Then ψ is given by

$$\psi = \Omega \sqrt{\frac{\sigma}{\pi G}} \sqrt{S} = 2\omega \sqrt{S} \quad (\text{III.13.1})$$

denoting the parameter $\Omega \sqrt{\sigma/\pi G}$ by the symbol 2ω .

To find the motion with this type of rotation, we must solve the same equations that we did for the spinning rocket with constant angular acceleration, but using $\psi = 2\omega \sqrt{S}$ instead of $\psi = \gamma S$. As in Sec. 12, we shall first find the contribution made by Λ to the solution.

We have

$$\begin{aligned} \sqrt{S} \delta = \frac{\sigma \Lambda}{8\pi k^2} \left\{ -j \exp(jS) \int_P^S \frac{1}{\sqrt{x}} \exp[j(2\omega \sqrt{x} - x)] dx \right. \\ \left. + j \exp(-jS) \int_P^S \frac{1}{\sqrt{x}} \exp[j(2\omega \sqrt{x} + x)] dx \right\} \end{aligned}$$

To evaluate the first integral occurring here, we proceed as follows: We multiply in front of the integral sign by the constant $\exp(j\omega^2)$ and under the integral by $\exp(-j\omega^2)$. The argument of the exponential function under the integral sign is now $-j(\omega^2 - 2\omega \sqrt{x} + x)$ or $-j(\omega - \sqrt{x})^2$. Then we make a change of variable by letting $y = (\omega - \sqrt{x})^2$, or

$$\sqrt{y} = \pm(\omega - \sqrt{x})$$

and

$$\frac{dy}{\sqrt{y}} = \mp \frac{dx}{\sqrt{x}}$$

Whether we choose the plus or the minus sign depends upon which branch of \sqrt{y} we want. We must use that branch which makes $\sqrt{y} \geq 0$, so that the decision depends upon the relative sizes of ω and \sqrt{x} . The value of ω is

$$\omega = \frac{\Omega}{2} \sqrt{\frac{\sigma}{\pi G}}$$

ω can be interpreted physically as $\frac{1}{2}/\sqrt{\pi}$ times the number of radians turned through in the first half wave length of yaw. σ is not likely to be less than 200 ft and G is not likely to be greater than 6,000 ft/sec². Values of Ω which would be used in practice are probably not less than

(15)(2 π) rad/sec, or 15 rps. These figures give ω a value of 5.21, so we shall say that $\omega > 5$. S is not likely to exceed 25 at the end of burning, so that $\sqrt{S} < 5$. But the maximum value of x above is the value of S at the end of burning, so that $(\omega - \sqrt{x}) > 0$, and we use

$$\sqrt{y} = \omega - \sqrt{x} \quad \frac{dy}{\sqrt{y}} = -\frac{dx}{\sqrt{x}}$$

In this way, we have shown

$$\begin{aligned} -j \exp(jS) \int_P^S \frac{1}{\sqrt{x}} \exp[j(2\omega\sqrt{x} - x)] dx \\ = j \exp(jS + j\omega^2) \int_{(\omega - \sqrt{P})^2}^{(\omega - \sqrt{S})^2} \frac{1}{\sqrt{y}} \exp(-jy) dy \end{aligned}$$

The integral is now in a form which we recognize. We evaluate the second integral in $\sqrt{S} \delta$ in a similar way. Dividing by \sqrt{S} ,

$$\begin{aligned} \delta = \frac{\sigma\Lambda}{8\pi k^2 \sqrt{S}} \{ \exp(2j\omega\sqrt{S}) [\overline{rc}(\omega + \sqrt{S})^2 \\ - rc(\omega - \sqrt{S})^2] + rc(\omega - \sqrt{P})^2 \exp[j(S - P + 2\omega\sqrt{P})] \\ - \overline{rc}(\omega + \sqrt{P})^2 \exp[-j(S - P - 2\omega\sqrt{P})] \} \quad (\text{III.13.2}) \end{aligned}$$

When we write such a form as $rc(\omega - \sqrt{S})^2$, we mean the function of the argument $(\omega - \sqrt{S})^2$, not the square of the function whose argument is $(\omega - \sqrt{S})$. (III.13.2) satisfies the boundary conditions $\delta = 0$ and $\delta' = 0$ at $S = P$. To find δ' , we differentiate δ with respect to S

$$\begin{aligned} \delta' = -\frac{\delta}{2S} - j \frac{\sigma\Lambda}{8\pi k^2 \sqrt{S}} \{ \exp(2j\omega\sqrt{S}) [\overline{rc}(\omega + \sqrt{S})^2 + rc(\omega - \sqrt{S})^2] \\ - rc(\omega - \sqrt{P})^2 \exp[j(S - P + 2\omega\sqrt{P})] \\ - \overline{rc}(\omega + \sqrt{P})^2 \exp[-j(S - P - 2\omega\sqrt{P})] \} \end{aligned}$$

From (III.3.11),

$$\theta = -\delta + \int_P^S \left(\delta' + \frac{\delta}{2S} \right) dS \quad (\text{III.13.3})$$

We see that we need the two integrals

$$\int_P^S \frac{1}{\sqrt{x}} \exp(2j\omega\sqrt{x}) rc(\omega - \sqrt{x})^2 dx \quad (\text{III.13.4})$$

and

$$\int_P^S \frac{1}{\sqrt{x}} \exp(2j\omega\sqrt{x}) \overline{rc}(\omega + \sqrt{x})^2 dx \quad (\text{III.13.5})$$

In estimating these quantities, we take advantage of the sizes of ω

and S . ω , in practice, will usually exceed S . S may become as large as 25, but such a size is unusual, at least at present. Even if S is this large, most of the change in θ occurs while S is less than π , so we would probably not make a serious error by taking S to be no larger than, say, 4. If we do so, $\sqrt{S} \leq 2$, and $(\omega - \sqrt{S})^2 \geq 9$, $(\omega + \sqrt{S})^2 \geq 49$.

The asymptotic expansion of $rc(w)$ is

$$rc(w) \doteq \frac{1}{\sqrt{w}} \left[1 + \frac{j}{2w} - \frac{1 \cdot 3}{(2w)^2} \cdot \cdot \cdot \right]$$

If $w = 9$, the magnitude of the second term is about 5 per cent that of the first. For our present purposes we are justified in using just the first term of the asymptotic expansion of the function $rc(\omega - \sqrt{S})^2$ and $\overline{rc}(\omega + \sqrt{S})^2$ in evaluating the integrals (III.13.4) and (III.13.5).

Substituting $[1/(\omega - \sqrt{x})]$ for $rc(\omega - \sqrt{x})^2$ in (III.13.4), the integral is

$$\int_P^S \frac{\exp(2j\omega \sqrt{x})}{\sqrt{x}(\omega - \sqrt{x})} dx$$

Changing to the variable $y = 2\omega(\omega - \sqrt{x})$, this is

$$-2 \int_{2\omega(\omega - \sqrt{P})}^{2\omega(\omega - \sqrt{S})} \frac{1}{y} \exp[j(2\omega^2 - y)] dy$$

The exponential function can be expanded as $\exp(2j\omega^2)[\cos y - j \sin y]$, so that we have expressed this integral in terms of the sine and cosine integrals. The definitions of these functions [see (III.7.61) and (III.7.62)] and their asymptotic series are

$$Si(w) = \int_0^w \frac{1}{x} \sin x dx \doteq \frac{\pi}{2} - \frac{1}{w} \cos w + \cdot \cdot \cdot$$

$$Ci(w) = \int_w^\infty \frac{1}{x} \cos x dx \doteq \frac{1}{w} \sin w + \cdot \cdot \cdot$$

By carrying out the necessary algebra, we finally obtain

$$\begin{aligned} \int_P^S \frac{1}{\sqrt{x}} \exp(2j\omega \sqrt{x}) rc(\omega - \sqrt{x})^2 dx \\ = -\frac{j \exp(2j\omega \sqrt{S})}{\omega(\omega - \sqrt{S})} + \frac{j \exp(2j\omega \sqrt{P})}{\omega(\omega - \sqrt{P})} \end{aligned} \quad \text{(III.13.6)}$$

By a similar process,

$$\begin{aligned} \int_P^S \frac{1}{\sqrt{x}} \exp(2j\omega \sqrt{x}) \overline{rc}(\omega + \sqrt{x})^2 dx \\ = -\frac{j \exp(2j\omega \sqrt{S})}{\omega(\omega + \sqrt{S})} + \frac{j \exp(2j\omega \sqrt{P})}{\omega(\omega + \sqrt{P})} \end{aligned} \quad \text{(III.13.7)}$$

Using these, we can evaluate θ by (III.13.3)

$$\begin{aligned} \theta = \frac{\sigma\Lambda}{8\pi k^2} & \left\{ \frac{1}{\sqrt{S}} [rc(\omega - \sqrt{S})^2 - \overline{rc}(\omega + \sqrt{S})^2] \exp(2j\omega\sqrt{S}) \right. \\ & - \frac{1}{\sqrt{S}} \exp(2j\omega\sqrt{P}) [rc(\omega - \sqrt{P})^2 \exp(jS - jP) \\ & - \overline{rc}(\omega + \sqrt{P})^2 \exp(-jS + jP)] \\ & - \frac{2}{\omega^2 - S} \exp(2j\omega\sqrt{S}) + \frac{2}{\omega^2 - P} \exp(2j\omega\sqrt{P}) \\ & + rc(\omega - \sqrt{P})^2 \exp[-j(P - 2\omega\sqrt{P})] [\overline{rc}(S) \exp(jS) \\ & - \overline{rc}(P) \exp(jP)] - \overline{rc}(\omega + \sqrt{P})^2 \exp[j(P \\ & + 2\omega\sqrt{P})] [rc(S) \exp(-jS) - rc(P) \exp(-jP)] \left. \right\} \quad \text{(III.13.8)} \end{aligned}$$

If ω is so large that we can use only the first term in the asymptotic series for $rc(\omega - \sqrt{P})^2$, $\overline{rc}(\omega + \sqrt{P})^2$, etc., this can be simplified to

$$\begin{aligned} \theta \approx \frac{\sigma\Lambda}{8\pi k^2} & \left\{ \frac{2}{\omega^2} \exp(2j\omega\sqrt{P}) \right. \\ & - \frac{1}{\omega} \exp[j(S - P + 2\omega\sqrt{P})] \left[\frac{1}{\sqrt{S}} - \overline{rc}(S) \right] \\ & + \frac{1}{\omega} \exp[-j(S - P - 2\omega\sqrt{P})] \left[\frac{1}{\sqrt{S}} - rc(S) \right] \\ & \left. + j \frac{2}{\omega} rj(P) \exp(2j\omega\sqrt{P}) - \frac{2}{\omega^2} \sqrt{P} rr(P) \exp(2j\omega\sqrt{P}) \right\} \quad \text{(III.13.9)} \end{aligned}$$

This relation contains a very interesting result, but one which is concealed in its present form. At present, it is referred to a coordinate system with the real axis vertical. Let us rotate the coordinate system by the angle $2\omega\sqrt{P}$, that is, by the angle through which the rocket turns between $S = 0$ and launching. We perform this rotation by multiplying by $\exp(-2j\omega\sqrt{P})$, so that, for large ω

$$\begin{aligned} \theta \approx \frac{\sigma\Lambda}{8\pi k^2} & \left\{ \frac{2}{\omega^2} - \frac{2}{\omega^2} \sqrt{P} rr(P) + j \frac{2}{\omega} \left[rj(P) \right. \right. \\ & \left. \left. - \frac{1}{\sqrt{S}} \sin(S - P) + ra(S) \sin(S - rt(S) - P) \right] \right\} \\ & = \frac{\sigma\Lambda}{8\pi k^2} \left[\frac{2}{\omega^2} - \frac{2}{\omega^2} \sqrt{P} rr(P) + j \frac{2}{\omega} \frac{G_4}{\sqrt{P}} \right] \quad \text{(III.13.10)} \end{aligned}$$

The real part of this expression varies inversely as ω^2 , while the imaginary part varies inversely as ω , so that, for large ω , the real part is negligible. Therefore, for high rates of spin, most of the dispersion

due to L is at right angles to the direction of L at launching, instead of being in line with it as we might expect.

We find the contribution to θ from δ_r by a process similar to that used for L . We shall not try to find the contribution to θ from δ_M , because our experience in Sec. 12 showed us that this is negligible for rockets with $\gamma > 2$. For a rocket with a burnt velocity of 1,000 ft/sec and $\sigma = 200$ ft, $\gamma = 2$ means one turn in 100 ft, or 10 rps at the end of burning. We can feel sure that dispersion will be even lower if this rate of rotation prevailed at launching. The desired value of θ is

$$\begin{aligned} \theta = & \frac{\Delta r}{4} \left\{ \frac{j}{\sqrt{S}} [rc(\omega - \sqrt{S})^2 + \bar{r}c(\omega + \sqrt{S})^2] \exp(2j\omega \sqrt{S}) \right. \\ & - \frac{j}{\sqrt{S}} \exp(2j\omega \sqrt{P}) [rc(\omega - \sqrt{P})^2 \exp(jS - jP) \\ & + \bar{r}c(\omega + \sqrt{P})^2 \exp(-jS + jP)] - \frac{j^2 \sqrt{S} \exp(2j\omega \sqrt{S})}{\omega(\omega^2 - S)} \\ & + \frac{j^2 \sqrt{P} \exp(2j\omega \sqrt{P})}{\omega(\omega^2 - P)} + jrc(\omega - \sqrt{P})^2 \exp[-j(P \\ & - 2\omega \sqrt{P})] [\bar{r}c(S) \exp(jS) - \bar{r}c(P) \exp(jP)] + j\bar{r}c(\omega + \sqrt{P})^2 \exp[j(P \\ & \left. + 2\omega \sqrt{P})] [rc(S) \exp(-jS) - rc(P) \exp(-jP)] \right\} \quad (\text{III.13.11}) \end{aligned}$$

Making the assumptions appropriate to large ω and multiplying by $\exp(-2j\omega \sqrt{P})$ to rotate the coordinate system,

$$\begin{aligned} \theta \approx & \frac{\Delta r}{4} \left(-\frac{2}{\omega \sqrt{S}} \sin [2\omega (\sqrt{S} - \sqrt{P})] \right. \\ & + j \frac{2}{\omega} \left\{ \frac{1}{\sqrt{S}} \cos [2\omega (\sqrt{S} - \sqrt{P})] - rr(P) - \frac{1}{\sqrt{S}} \cos (S - P) \right. \\ & \left. \left. + ra(S) \cos [S - P - rt(S)] \right\} - \frac{2 \sqrt{P} rj(P)}{\omega^2} \right) \\ = & \frac{\Delta r}{4} \left(-\frac{2 \sqrt{P} rj(P)}{\omega^2} - \frac{2 \sin [2\omega (\sqrt{S} - \sqrt{P})]}{\omega \sqrt{S}} \right. \\ & \left. + \frac{2j}{\omega} \left\{ \frac{G_s}{\sqrt{P}} - \frac{1}{\sqrt{P}} + \frac{\cos [2\omega (\sqrt{S} - \sqrt{P})]}{\sqrt{S}} \right\} \right) \quad (\text{III.13.12}) \end{aligned}$$

For large ω , θ varies inversely as ω .

To find the motion in a vacuum, we proceed as in Sec. 12, except that we replace G_s by $\Omega t = \sqrt{(2/G)} \Omega \sqrt{s}$ for the angle turned through about the axis of symmetry. The boundary conditions on these equations are $\delta_p = 0$, $(d\delta/ds)_p = (\Delta r/2p) \exp [j \sqrt{(2/G)} \Omega \sqrt{p}]$.

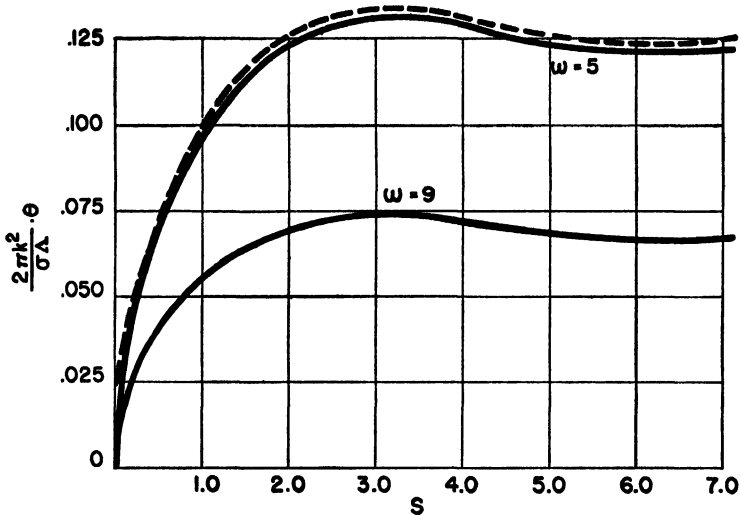

FIG. III.13.1.—Dispersion due to jet malalignment distance for a slowly spinning rocket launched from a zero-length launcher. Dashed line gives approximate value as defined by (III.13.10).

k = radius of gyration about a transverse axis through the C.G.
 σ = wave length of yaw.
 Λ = jet malalignment distance.
 ω as defined by (III.13.1).

The solutions for θ and δ are

$$\delta = \frac{G\Lambda}{k^2\Omega^2} \left\{ -\exp(j\psi) - j\frac{1}{\psi} [\exp(j\psi) - \exp(j\psi_p)] + j\frac{\psi}{2s} (s-p) \exp(j\psi_p) + \frac{\sqrt{p}}{\sqrt{s}} \exp(j\psi_p) \right\} - j\frac{\Delta r}{\psi} [\exp(j\psi) - \exp(j\psi_p)] \quad \text{(III.13.13)}$$

$$\theta = \frac{2\Lambda s}{k^2\psi^2} \left\{ j\frac{1}{\psi} [\exp(j\psi) - \exp(j\psi_p)] + (1 - j\psi_p) \exp(j\psi_p) + \frac{1}{2} j\psi \left(1 + \frac{p}{s}\right) \exp(j\psi_p) - \frac{\sqrt{p}}{\sqrt{s}} \exp(j\psi_p) \right\} + j\frac{\Delta r}{\psi} [\exp(j\psi) - \exp(j\psi_p)] \quad \text{(III.13.14)}$$

In these, ψ is the angle turned through by the rocket, and ψ_p is the value of ψ at $s = p$. Multiplying by $\exp(-j\psi_p)$, and noting that $\psi_p = \psi \sqrt{p/s}$, θ can be simplified to

$$\theta = \frac{2\Lambda s}{k^2\psi^2} \left\{ \frac{j}{\psi} [\exp(j\Delta\psi) - 1] + \left(1 + \frac{1}{2}j\Delta\psi\right) \left(1 - \sqrt{\frac{p}{s}}\right) \right\} + j\frac{\Delta r}{\psi} [\exp(j\Delta\psi) - 1] \quad \text{(III.13.15)}$$

where $\Delta\psi = \psi - \psi_p$. For large ω

$$\theta = j \frac{\Delta}{k^2\psi} (\sqrt{s} - \sqrt{p})^2 + j \frac{\Delta r}{\psi} [\exp(j\Delta\psi) - 1] \quad \text{(III.13.16)}$$

As with the solution in air, the dispersion varies inversely with the

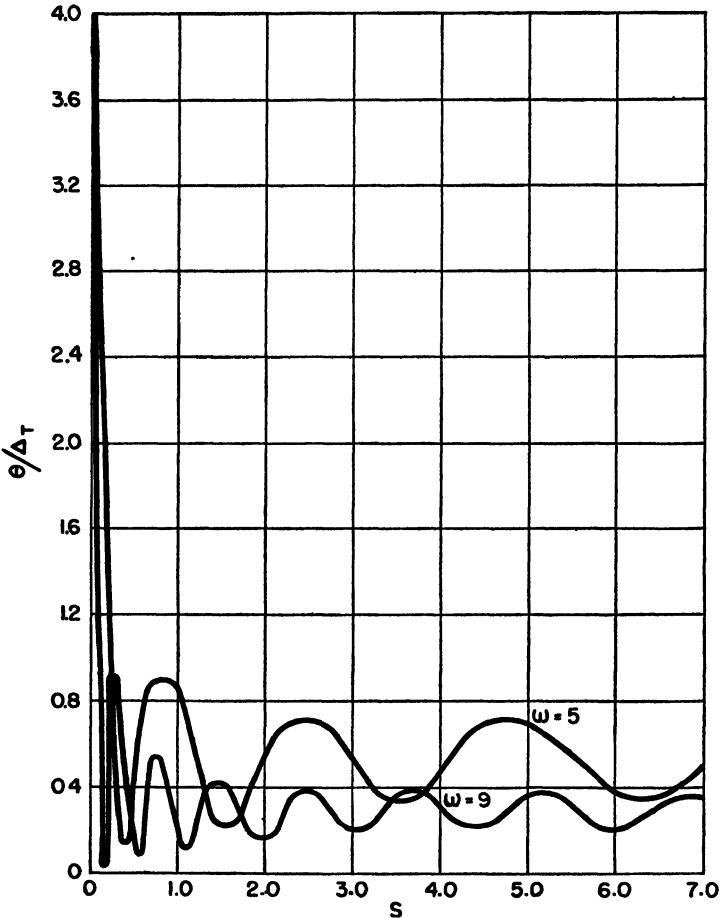

Fig. III.13.2.—Dispersion due to jet malalignment angle for a slowly spinning rocket launched from a zero-length launcher.
 Δr = jet malalignment angle.
 ω as defined by (III.13.1).

angular velocity. Again we find that the dispersion due to L is greater in a direction perpendicular to L at launching than it is in the direction of L .

In Figs. III.13.1 and III.13.2, we have plotted the absolute values

of θ as functions of S , with $P = 0$, for two values of ω . The solid curves were obtained by numerical integration. The dashed line in Fig. III.13.1 was computed from (III.13.10). The corresponding dashed line for $\omega = 9$ lay so close to the solid line that no effort was

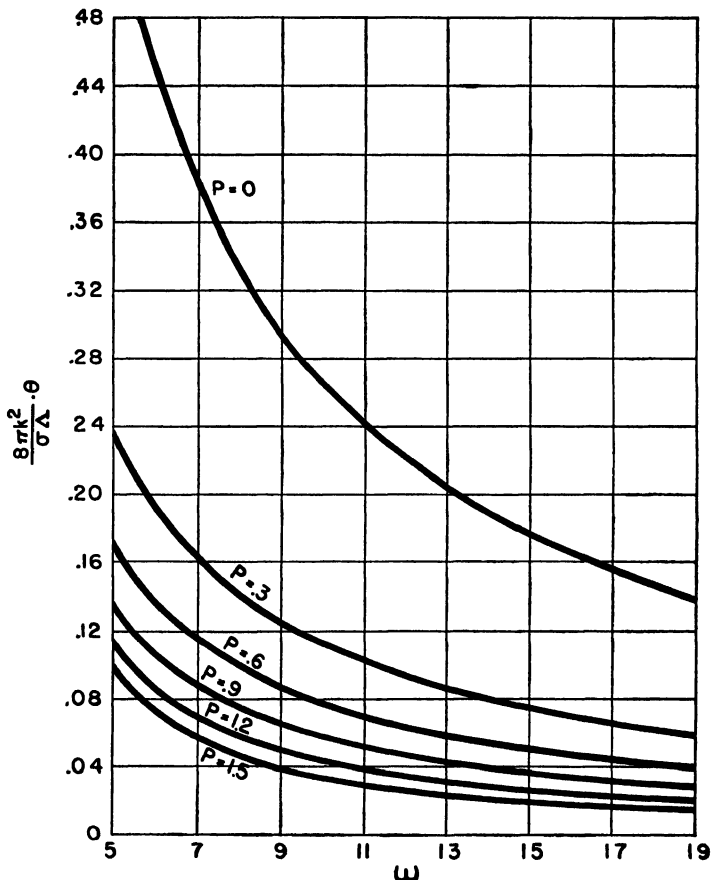

Fig. III.13.3.—Dispersion due to jet misalignment distance for a slowly spinning rocket with burning distance equal to a half wave length of yaw.
 k = radius of gyration about a transverse axis through the C.G.
 σ = wave length of yaw.
 Λ = jet misalignment distance.
 ω as defined by (III.13.1).

made to show it. Similarly, in Fig. III.13.2, dashed lines computed from (III.13.12) lay too close to the solid lines to show separately.

In Figs. III.13.3 and III.13.4, we have plotted θ as a function of ω , with $S = \pi$, for various values of P . θ was computed from (III.13.10) for Fig. III.13.3 and from (III.13.12) for Fig. III.13.4.

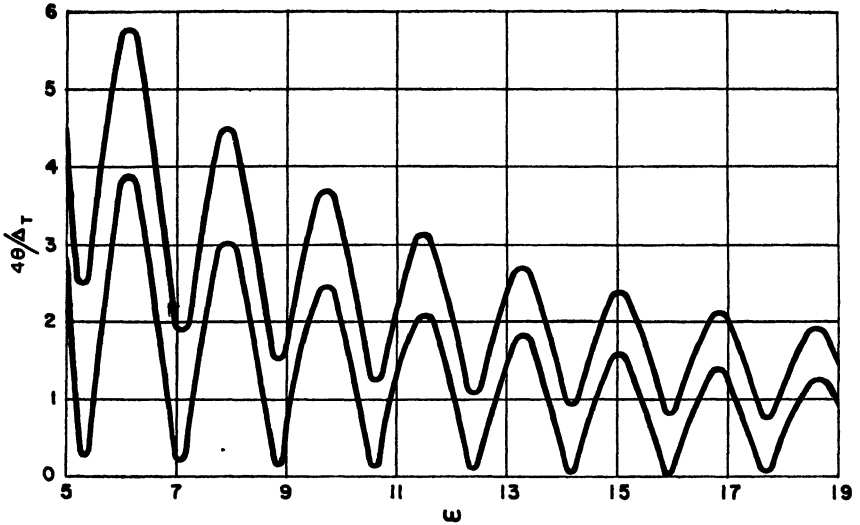

FIG. III.13.4.—Dispersion due to jet malalignment angle for a slowly spinning rocket with burning distance equal to a half wave length of yaw. The upper curve is for $P = 0$ and the lower curve is for $P = 1.5$. Curves for intermediate values of P would lie between at nearly proportional distances.

Δ_T = jet malalignment angle.
 ω as defined by (III.13.1).

14. Motion during Burning of an Unstable Rocket

By an unstable rocket is meant one for which K_M is negative.

The reader might feel that there is no point in studying rockets with this type of moment, because no one would ever want to build an unstable rocket. Actually, there are at least two known applications of the motion of an unstable rocket. Fin-stabilized rockets to be fired from a tube are usually equipped with folding fins, which do not open for some time after the rocket has left the tube. For a short time, until the fins are at least partly open, the rocket is unstable. We shall indicate that, for fins built to open rapidly, this instability can be ignored in ground firing; that is, we can compute the behavior of the rocket as if it were stable during all of burning. In firing with a high velocity at launching, as from an airplane, it may be necessary to make a correction for fin opening.

There are some rockets which are stable in the sense that, if a yaw is set up, they tend to return to an equilibrium yaw, but which still obey the theory of the unstable rocket over part of their motion. Such a rocket might have an upsetting moment curve like that shown in Fig. III.14.1.

To find the equations of motion of the unstable rocket, it is con-

venient to change the sign of K_M where it occurs in the equations of motion of the stable rocket. We shall not bother to introduce a different symbol for the coefficient. As with the stable rocket, we let $k_M = K_M/I$ and use a quantity, which we call σ , defined just as σ is defined, namely,

$$\sigma = \frac{2\pi}{\sqrt{k_M \rho d^3}} \quad (\text{III.14.1})$$

This is purely a formal definition; σ has no particularly useful physical interpretation. As the independent variable used in describing the motion, we use

$$S = \frac{2\pi}{\sigma} s$$

The reader can readily verify that (III.3.20) is correct for the unstable rocket. We are going to find, for the unstable rocket, only the analogue to the basic solution of Sec. 1 for the stable rocket.

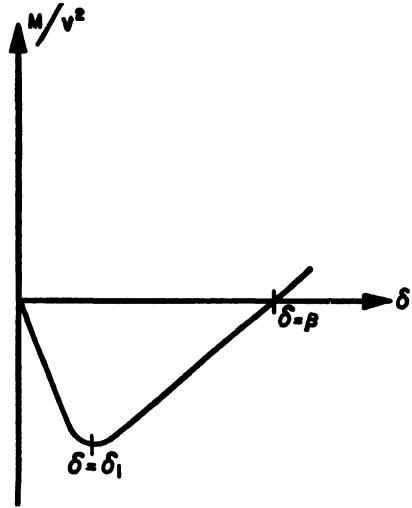

FIG. III.14.1.—Example of upsetting moment curve.
 M = upsetting moment.
 v = velocity.
 δ = yaw.

Therefore, we assume constant acceleration and no rotation and neglect jet damping and all the aerodynamic coefficients except k_M . With these assumptions and emendations, (III.3.20) reduces to

$$(\sqrt{S} \delta)'' - \sqrt{S} \delta = - \frac{1}{4S \sqrt{S}} \left(\delta_r + \frac{g \cos \theta_a}{G} \right) + \frac{\sigma L}{2\pi k^2} \frac{1}{2 \sqrt{S}} - \sqrt{S} \delta_M = Q(S) \quad (\text{III.14.2})$$

(III.3.11) reduces to

$$\theta = \theta_p + \delta_p - \delta + \int_P^S \left[\delta' + \frac{\delta - \delta_x - (g \cos \theta_a/G)}{2S} \right] dS \quad (\text{III.14.3})$$

As boundary conditions on these equations, $\delta = \delta_p$, $\phi' = \phi'_p$, and $\theta = \theta_p$ when $S = P$.

The solution of (III.14.2) that satisfies the boundary conditions is

$$\begin{aligned} \sqrt{S} \delta = & \frac{1}{2} [\sqrt{P} \delta_p + (\sqrt{S} \delta)'_p] \exp(S - P) + \frac{1}{2} [\sqrt{P} \delta_p \\ & - (\sqrt{S} \delta)'_p] \exp[-(S - P)] + \frac{1}{2} \exp(S) \int_P^S Q(x) \exp(-x) dx \\ & - \frac{1}{2} \exp(-S) \int_P^S Q(x) \exp(x) dx \quad (\text{III.14.4}) \end{aligned}$$

In terms of δ_p and ϕ'_p ,

$$(\sqrt{S} \delta)'_p = \left(\sqrt{P} \phi'_p + \frac{\delta_T}{2\sqrt{P}} + \frac{g \cos \theta_a}{2G\sqrt{P}} \right)$$

The integrals that we use to express δ and θ are defined by

$$I_1(u) = \int_0^u \frac{1}{\sqrt{x}} \exp(x) dx \quad (\text{III.14.5})$$

$$I_2(u) = \int_u^\infty \frac{1}{\sqrt{x}} \exp(-x) dx \quad (\text{III.14.6})$$

$$id(u) = \int_0^u [I_2(x) \exp(x) + I_1(x) \exp(-x)] \frac{1}{\sqrt{x}} dx \quad (\text{III.14.7})$$

A brief discussion of these functions, and the tables necessary for computation, are given in Appendix 4.

The values of δ and θ are

$$\begin{aligned} \delta = & \left(\frac{\delta_T}{4\sqrt{S}} + \frac{g \cos \theta_a}{4G\sqrt{S}} \right) \{ \exp(-S)[I_1(S) - I_1(P)] \\ & - \exp(S)[I_2(S) - I_2(P)] \} - \frac{\sigma L}{8\pi k^2 \sqrt{S}} \{ \exp(-S)[I_1(S) - I_1(P)] \\ & + \exp(S)[I_2(S) - I_2(P)] \} + \delta_M - \frac{\delta_M}{4\sqrt{S}} \{ 4\sqrt{P} \cosh(S-P) \\ & - \exp(S)[I_2(S) - I_2(P)] + \exp(-S)[I_1(S) - I_1(P)] \} \\ & + \frac{\sqrt{P} \delta_p}{\sqrt{S}} \cosh(S-P) + \frac{\sqrt{P} \phi'_p}{\sqrt{S}} \sinh(S-P) \quad (\text{III.14.8}) \end{aligned}$$

$$\begin{aligned} \theta = & \left(\delta_T + \frac{g \cos \theta_a}{G} \right) H_1 + \frac{\sigma L}{2\pi k^2} H_2 - \delta_M(H_1 + H_3) \\ & + \delta_p H_3 + \phi'_p H_4 \quad (\text{III.14.9}) \end{aligned}$$

In this:

$$\begin{aligned} 4H_1 = & id(P) - id(S) + I_2(P) \left[I_1(S) - \frac{1}{\sqrt{S}} \exp(S) \right] \\ & - I_1(P) \left[I_2(S) - \frac{1}{\sqrt{S}} \exp(-S) \right] + I_2(S) \frac{1}{\sqrt{S}} \exp(S) \\ & - I_1(S) \frac{1}{\sqrt{S}} \exp(-S) \quad (\text{III.14.10}) \end{aligned}$$

$$\begin{aligned} 4H_2 = & [I_1(S) - I_1(P)] \left[I_2(P) - I_2(S) + \frac{1}{\sqrt{S}} \exp(-S) \right] \\ & + [I_2(S) - I_2(P)] \frac{1}{\sqrt{S}} \exp(S) \quad (\text{III.14.11}) \end{aligned}$$

$$H_3 = 1 + \frac{1}{2} \sqrt{P} \left\{ \exp(-P)[I_1(S) - I_1(P)] + \exp(P)[I_2(S) - I_2(P)] - \frac{2}{\sqrt{S}} \cosh(S - P) \right\} \quad \text{(III.14.12)}$$

$$H_4 = \frac{1}{2} \sqrt{P} \left\{ \exp(-P)[I_1(S) - I_1(P)] - \exp(P)[I_2(S) - I_2(P)] - \frac{2}{\sqrt{S}} \sinh(S - P) \right\} \quad \text{(III.14.13)}$$

It is usually necessary in applications to have the value of ϕ' . We find it by adding θ and δ , and differentiating the result with respect to S

$$\begin{aligned} \phi' = & \frac{\delta_r + (g \cos \theta_a/G)}{4 \sqrt{S}} \{ \exp(S)[I_2(P) - I_2(S)] \\ & - \exp(-S)[I_1(S) - I_1(P)] \} + \frac{\sigma L}{8\pi k^2 \sqrt{S}} \{ \exp(S)[I_2(P) \\ & - I_2(S)] + \exp(-S)[I_1(S) - I_1(P)] \} \\ & + \frac{\delta_M}{4 \sqrt{S}} \{ \exp(S)[I_2(S) - I_2(P)] + \exp(-S)[I_1(S) - I_1(P)] \\ & - 4 \sqrt{P} \sinh(S - P) \} + \frac{\sqrt{P} \delta_p}{\sqrt{S}} \sinh(S - P) \\ & + \frac{\sqrt{P} \phi'_e}{\sqrt{S}} \cosh(S - P) \quad \text{(III.14.14)} \end{aligned}$$

The use of this solution is quite like the use of the basic solution, and we shall not give a detailed example of its use. There is an important question, though, which we wish to answer with the help of this solution. This question is: In firing a rocket equipped with folding fins, can we neglect the time required for the fins to open and assume that the rocket is stable during all its flight? To answer this question, let us assume that a rocket with a burnt velocity of 1,000 ft/sec, relative to the launcher, and an acceleration of 2,000 ft/sec² is fired from an airplane flying at a speed of 500 ft/sec. We assume $\sigma = 200$ ft for the rocket after its fins are open. We should expect σ before the fins open to have a different value from, and usually greater than, σ after the fins open. In this case we assume $\sigma = 400$ ft before the fins open.

First, as the basis of comparison, we compute the value of θ at the end of burning on the assumption that the round is always stable. From the velocities and acceleration

$$p = \frac{(500)^2}{2(2,000)} = 62.5 \text{ ft} \quad s = \frac{(1,500)^2}{2(2,000)} = 562.5 \text{ ft}$$

$$P = 2\pi \frac{62.5}{200} = 1.9635 \quad S = 2\pi \frac{562.5}{200} = 17.6715$$

Let us assume that $g = \delta_r = \delta_M = \phi'_p = 0$, so that we are finding only the effect of δ_p and the dispersion due to L . Using approximations (III.1.62) to (III.1.65), we find for the value of θ at the end of burning

$$\theta_1 = 0.0929\delta_p + \frac{\sigma L}{8\pi k^2} 0.3779$$

Let us suppose that 0.05 sec are required for the fins to open, and assume that they are fully closed until this length of time after firing and fully open after this time. In 0.05 sec, the round gains 100 ft/sec of velocity, so its velocity at fin opening is 600 ft/sec. Using a subscript f to denote the time of fin opening, and referring to the unstable rocket,

$$v_f = 600 \text{ ft/sec} \quad s_f = \frac{(600)^2}{2(2,000)} = 90 \text{ ft}$$

The values of P and S_f for the unstable rocket are

$$P = 2\pi \frac{62.5}{400} = 0.9818 \quad S_f = 2\pi \frac{90}{400} = 1.4137$$

Using (III.14.8), (III.14.9), and (III.14.14), and these values of P and S_f , we find

$$\delta_f = 0.9122\delta_p + 0.1506 \frac{\sigma_f L}{8\pi k^2} = 0.9122\delta_p + 0.3012 \frac{\sigma L}{8\pi k^2}$$

remembering that $\sigma_f = 2\sigma$ for the example chosen. Also

$$\theta_f = 0.1712\delta_p + 0.0176 \frac{\sigma L}{8\pi k^2}$$

$$\phi'_f = 0.3712\delta_p + 1.3764 \frac{\sigma L}{8\pi k^2}$$

After fin opening, the rocket is stable, so we use the basic solution of Sec. 1. The value of p to use is 90 ft, and s is of course again 562.5 ft. The values of δ_p and θ_p to use are just the values of δ_f and θ_f above. The value of ϕ'_p is related to the value of ϕ'_f as follows:

$$\begin{aligned} \phi'_p &= \frac{\sigma}{2\pi} \left(\frac{d\phi}{ds} \right)_p = \frac{\sigma}{2\pi} \frac{2\pi}{s_f} \left(\frac{d\phi}{dS} \right)_f \\ &= \frac{\sigma}{\sigma_f} \phi'_f \end{aligned}$$

For this example

$$\phi'_p = 0.1856\delta_p + 0.6882 \frac{\sigma L}{8\pi k^2}$$

The values of P and S are

$$P = 2\pi \frac{90}{2,000} = 2.8274 \quad S = 17.6715$$

Using approximations (III.1.62) to (III.1.65),

$$G_2 = 0.0661 \quad G_3 = 0.0574 \quad G_4 = 0.1381$$

From these, and (III.1.6)

$$\begin{aligned} \theta_b &= 0.1712\delta_p + 0.0176 \frac{\sigma L}{8\pi k^2} \\ &+ 0.2644 \frac{\sigma L}{8\pi k^2} + (0.0574)(0.9122)\delta_p \\ &+ (0.0574)(0.3012) \frac{\sigma L}{8\pi k^2} \\ &+ (0.1381)(0.1856)\delta_p + (0.1381)(0.6882) \frac{\sigma L}{8\pi k^2} \\ &= 0.2492\delta_p + 0.3943 \frac{\sigma L}{8\pi k^2} \end{aligned}$$

Comparing these with the values which we should have found by assuming the round to be stable through all its motion, we see that the dispersion due to L is not greatly affected, but the value of θ resulting from a value of δ_p is changed quite appreciably.

15. Motion during Burning with a Large Initial Yaw

If a rocket is launched from an aircraft in such a fashion that its axis does not point closely along the line of flight, the initial angle of yaw may be as large as 90° . For such a situation, the treatment of this chapter is not applicable, since we have assumed that δ is always small. In this section, we outline a method of computing the motion during burning, assuming that the trajectory lies in the vertical plane containing the line of flight of the aircraft, thus restricting ourselves to situations in which the rocket is launched with its axis in a vertical plane.

Instead of using s and θ as coordinates, we find it more convenient to use rectangular coordinates to describe the location of the center of gravity. We take the x axis to be horizontal and pointing along the line of flight of the aircraft and the y axis vertical and pointing upward.

We assume that the rocket is launched pointing in an upward direction. The modifications to make if the rocket is initially pointing downward are readily seen. The origin of x and y is now to be taken at the position of the rocket when launched. The third coordinate which we shall use is ϕ , defined as it has been in the rest of this chapter.

We neglect all aerodynamic forces except the restoring moment. We neglect jet damping and assume that $\delta_T = 0$. Using G to denote the acceleration of the rocket due to the jet, the x component of acceleration is

$$\ddot{x} = G \cos \phi \quad (\text{III.15.1})$$

The y component of acceleration is

$$\ddot{y} = G \sin \phi - g$$

It is usually the case that g is negligible compared with $G \sin \phi$, so that

$$\ddot{y} = G \sin \phi \quad (\text{III.15.2})$$

Under our assumptions, the only torques tending to rotate the rocket about an axis perpendicular to the xy plane are the restoring torque $-K_M \rho d^3 v^2 \sin \delta$ and the torque caused by jet malalignment distance MGL . Therefore

$$I \ddot{\phi} = -K_M \rho d^3 v^2 \sin \delta + MGL$$

Dividing through by I , and letting $\lambda = (MGL/I)$,

$$\ddot{\phi} = -\frac{K_M \rho d^3}{I} v^2 \sin \delta + \lambda \quad (\text{III.15.3})$$

To solve for the motion during burning, we solve (III.15.1), (III.15.2), and (III.15.3), for \dot{x} and \dot{y} , and x and y . We find θ from

$$\theta = \tan^{-1} \frac{\dot{y}}{\dot{x}} \quad (\text{III.15.4})$$

If the angle of yaw is always small, the vacuum approximation is a poor approximation to the motion during burning. However, if the angle of yaw is large, the vacuum approximation is reasonably good. Therefore, we take as a first approximation the vacuum solution obtained by setting $K_M = 0$ in (III.15.3). For the present, we shall not consider dispersion, so we also set $\lambda = 0$. Using a subscript p to denote the time of launching, and taking $t = 0$ at launching, (III.15.3) integrates immediately to

$$\phi = \phi_p$$

if $\dot{\phi}_p = 0$. (III.15.1), (III.15.2), and (III.15.4) give

$$\left. \begin{aligned} \dot{x} &= \dot{x}_p + Gt \cos \phi_p & \dot{y} &= \dot{y}_p + Gt \sin \phi_p \\ \theta &= \tan^{-1} \frac{\dot{y}_p + Gt \sin \phi_p}{\dot{x}_p + Gt \cos \phi_p} \\ v^2 &= \dot{x}^2 + \dot{y}^2 = v_p^2 + 2v_p Gt \sin \phi_p + G^2 t^2 \end{aligned} \right\} \quad \text{(III.15.5)}$$

In these, v_{ϕ_p} is the component of v_p along the direction ϕ_p . δ , if desired, is given by $\phi_p - \theta$.

Before proceeding with the solution in air, we must know the nature of K_M . For small values of δ and v , K_M is a constant, but it varies quite erratically for large δ . Figure III.15.1 shows how the restoring torque for an M8 rocket varies with δ , for δ up to 90° , at low velocity. The ordinates in Fig. III.15.1 are proportional to $K_M \rho d^3 \sin \delta$, so we

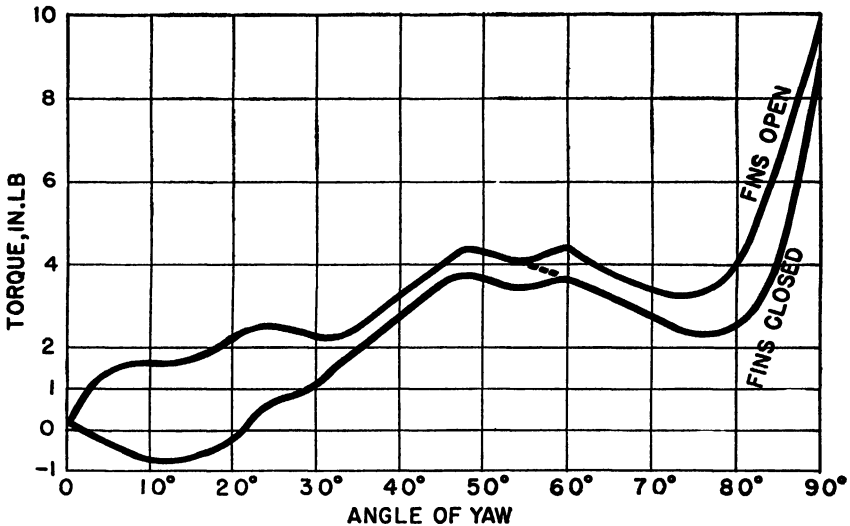

FIG. III.15.1.—Torque versus angle of yaw for an M8 rocket. Air speed = 50 ft/sec. Dashed line is curve used in numerical integration.

see that K_M varies in quite an erratic fashion indeed. We shall assume that K_M is independent of v , so that we can write the quantity $-(K_M \rho d^3 / I) \sin \delta$ as some function of δ only, say, $f(\delta)$.

Again setting $\lambda = 0$ for the present, we can write (III.15.3) in the form

$$\dot{\phi} = v^2 f(\delta)$$

If v and δ are known as functions of time, this can be integrated to give ϕ , and from ϕ we can find \dot{x} , \dot{y} , and θ . But v and δ are known approximately from the vacuum solution, so that we can use the vacuum solution in finding an approximation to ϕ .

For the M8, we can approximate $f(\delta)$ fairly well by a constant, if δ is larger than about 10° and smaller than about 75° , as we can see from Fig. III.15.1. For other types of rockets, the form of $f(\delta)$ will probably be nothing like its form for the M8. We cannot say what $f(\delta)$ will be like; so far as we know, the M8 rocket is the only one for which aerodynamic measurements have been made at large angles of yaw. It should be possible to approximate $f(\delta)$ by the form $a + b\delta$.

In order to obtain a solution that reveals the principal points of the behavior during burning, we assume that $f(\delta)$ is given by a constant $-K$. This constant must be negative because of our sign conventions. Then,

$$\ddot{\phi} = -Kv^2$$

Substituting for v^2 from (III.15.5), and integrating,

$$\phi = \phi_p - Kt^2 \left(\frac{1}{2} v_p^2 + \frac{v_{\phi_p} Gt}{3} + \frac{G^2 t^2}{12} \right) \quad (\text{III.15.6})$$

Let us write ϕ as $\phi_p + \Delta\phi$, where $\Delta\phi$ can be found from (III.15.6). Substituting the value of ϕ into (III.15.1) and (III.15.2),

$$\begin{aligned} \ddot{x} &= G(\cos \phi_p \cos \Delta\phi - \sin \phi_p \sin \Delta\phi) \\ \ddot{y} &= G(\sin \phi_p \cos \Delta\phi + \cos \phi_p \sin \Delta\phi) \end{aligned} \quad (\text{III.15.7})$$

If these are compared with the values in a vacuum, it is seen that the corrections to the vacuum accelerations are first order in $\Delta\phi$. We shall neglect higher order terms in $\Delta\phi$, even though $\Delta\phi$ may be as large as 0.3 (about 20°). Approximately, then

$$\begin{aligned} \ddot{x} &= G \left[\cos \phi_p + Kt^2 \left(\frac{v_p^2}{2} + \frac{v_{\phi_p} Gt}{3} + \frac{G^2 t^2}{12} \right) \sin \phi_p \right] \\ \ddot{y} &= G \left[\sin \phi_p - Kt^2 \left(\frac{v_p^2}{2} + \frac{v_{\phi_p} Gt}{3} + \frac{G^2 t^2}{12} \right) \cos \phi_p \right] \end{aligned} \quad (\text{III.15.8})$$

These can be readily integrated to give \dot{x} , x , \dot{y} , y , θ , and δ .

If burning continues long enough, δ will become small enough that the ordinary methods for small yaw can be applied with sufficient accuracy. A reasonable criterion would be that if $\delta < 10^\circ$, the small yaw theory should be used. The boundary conditions for the application of the theory for small yaw would have to come from this solution given in this section, or from some other solution of the equations of motion.

It may happen that burning will continue long enough for δ to become large again, with the opposite sign from its original value. If

this happens, the solution which assumes small values of δ must be abandoned and methods appropriate to large δ used again.

The method outlined in this section has been applied to certain data. For comparison, (III.15.1), (III.15.2), and (III.15.3) were solved by numerical integration, using the torque curve given in Fig. III.15.1. In performing the numerical integration, we went from fins closed to fins open at the proper time, which carried us along the dashed line shown in Fig. III.15.1. This was probably an unnecessary refinement. The value of K to be used in applying the methods of this section was arbitrarily determined by taking the arithmetical average of the torques at 10° intervals from 20° to 70° yaw. The data used are

$$\begin{aligned} \phi_p &= 90^\circ & \dot{x}_p &= 386.5 \text{ ft/sec} & v_{\phi_p} &= \dot{y}_p = 107 \text{ ft/sec} \\ v_p &= 400 \text{ ft/sec} & G &= 6,000 \text{ ft/sec}^2 & I &= 20 \text{ lb ft}^2 \end{aligned}$$

Mean torque at 50 fps used = 3.02 in. lb whence

$$K = 1.62 \times 10^{-4}$$

We list the values obtained by the two methods.

x , ft	y , ft	\dot{x} , ft/sec	\dot{y} , ft/sec	θ°	δ°	ϕ°	$\dot{\phi}$, rad/sec
By present method							
48.27	56.04	456.6	827.0	61.10°	8.99°	70.09°	-7.97
By numerical integration							
48.31	55.87	458.8	819.1	60.75°	9.73°	70.48°	-6.63

The differences in the values of x and y are negligible, the error in θ is about one third of a degree, which is fair, and the error in ϕ is about 20 per cent. However, the error in ϕ will probably not produce any further serious effect upon θ . These errors could be reduced by choosing a slightly larger value of K . It might be that some kind of weighted mean should be used in computing K .

In continuing the trajectory beyond this value of t , the methods for small yaw should be used, using the values of θ , δ , and ϕ given here as boundary conditions.

We now turn to an estimate of the dispersion due to L . According to (III.15.3), having a malalignment L adds to the angular acceleration $v^2 f(\delta)$ an amount λ . Hence an amount $\frac{1}{2} \lambda t^2$ is added to ϕ . By

(III.15.7), then, we see that \dot{x} is changed by $-(\frac{1}{8})G\lambda t^3 \sin \phi_p$, and \dot{y} by $(\frac{1}{8})G\lambda t^3 \cos \phi_p$.

Let the values of \dot{x} , \dot{y} , and θ if $\lambda = 0$ be denoted by \dot{X} , \dot{Y} , and Θ . Then

$$\begin{aligned} \dot{x} &= \dot{X} - (\frac{1}{8})G\lambda t^3 \sin \phi_p & \dot{y} &= \dot{Y} + (\frac{1}{8})G\lambda t^3 \cos \phi_p \\ \tan \Theta &= \frac{\dot{Y}}{\dot{X}} & \tan \theta &= \frac{\dot{Y} + (\frac{1}{8})G\lambda t^3 \cos \phi_p}{\dot{X} - (\frac{1}{8})G\lambda t^3 \sin \phi_p} \end{aligned}$$

As an approximation, we find from the last of these that

$$\tan \theta = \tan \Theta + \frac{G\lambda t^3}{6\dot{X}} (\cos \phi_p + \sin \phi_p \tan \Theta)$$

From this, we see that the effect of malalignment is by no means independent of the boundary conditions, as it is with small angles of yaw. It seems probable that little additional dispersion will occur after the yaw becomes small, so that the t in this equation should be either the burning time or the time required for the yaw to become zero, whichever is smaller.

If $\phi_p = 90^\circ$, we can use $\dot{X} \cong \dot{x}_p$. The correction to $\tan \Theta$ is now approximately

$$G \frac{MGL}{I} \frac{t^3}{6\dot{x}_p} \tan \Theta = \frac{ML}{I} \frac{G^2 t^3}{6\dot{x}_p} \tan \Theta$$

\dot{x}_p is just the airplane speed, usually denoted by v_a . If the proper time to use is the burning time t_b , the correction is simply

$$\frac{ML}{I} \frac{v_b^2 t_b}{6v_a} \tan \Theta$$

Here $v_b = Gt_b$, which is the ground burnt velocity of the rocket considered. This expression should be useful in comparing the merits of different designs. It is important to notice that this dispersion is approximately independent of fin effects.

As a numerical example, let us use the round just considered and take its mass to be 35 lb, with a malalignment L of 0.030". Then the correction to $\tan \Theta$ at $t = 0.12$ sec is 0.21. At $\Theta = 61.1^\circ$ (from the tabulation above), we find that this change in $\tan \Theta$ changes Θ by about 0.05 rad, that is, a malalignment of 0.030" will produce a dispersion of about 0.05 rad under the assumed conditions.

No great accuracy is claimed for the method of computation assuming that $f(\delta)$ is constant, but its application is sufficiently simple that it should prove useful in preliminary studies of this method of firing

The character of the motion during burning with a large initial yaw is superficially different from that with a small initial yaw. With a small initial yaw, the value of θ produced by initial yaw alone is of the order of one-fifth as great as the yaw. With the large yaw used in the example of this section, the value of θ is of the order of two-thirds of the initial yaw. It was in connection with this fact, which was first observed experimentally, that controversies about jet damping arose. At one time, it was being asserted by some workers that only jet damping could produce the effects observed and that the effect of jet damping must be larger than the effect of the fins, since a rocket fired with a large initial yaw did not turn very far into the line of flight. We see from the results of this section that the assertion is incorrect; by neglecting jet damping we obtain an answer which is approximately correct. In more elaborate treatments, it will be necessary to include jet and aerodynamic damping, and they may well be relatively more important with a large initial yaw than they were with a small initial yaw.

16. Experimental Verification of the Theory. Importance of Various Sources of Dispersion

A complete study of the motion of rockets requires, of course, an analysis of the motion during all three periods, the launching period, the burning period, and the period after burning. For that reason, it might seem more appropriate to postpone this discussion until after the launching period has been studied. However, it is during burning that the most important effects arise that distinguish rockets from other projectiles; consequently, it is the theory of motion during burning that requires the greatest study.

The uses of the theory of rocket flight are two in number. The first use is in connection with sighting, that is, in predicting how a standard rocket should be fired in order to hit a given target. The second is to predict how close actual rockets will come to the point of aim, assuming that the point of aim has been computed correctly for a standard rocket. These two uses of the theory are distinct; that is, it does not follow that, if the theory is correct for one use, it also gives correct results for the other use. In this section, we wish to discuss briefly how much is known about the adequacy of our present theory for each of the two uses to which it is put.

From the fact that the sighting problem and the dispersion problem entail distinct uses of the theory, it does not follow that the sighting problem and the dispersion problem are independent. In practice,

they are very closely connected. For example, if a type of rocket has a dispersion of 50 mils, it is wasted labor to compute the point of aim within 1 mil. Correspondingly, if the trajectory of a standard rocket under certain firing conditions cannot be computed more closely than 10 mils, there is no point in reducing the dispersion much below this figure. Further, both accuracy of sighting and dispersion have a lower limit imposed by the same cause. There are unavoidable and uncontrollable fluctuations in the condition of the air through which the rocket passes, which cause dispersion. It is pointless to reduce the sighting error or the dispersion due to the ammunition much below this value.

To continue the main discussion, let us first consider the part of the theory that deals with sighting. To test this theory, all we have to do is to fire a rocket, compute from the position and orientation of the launcher the point at which the theory says the rocket should hit, and then go look for it there. Actually, we should be surprised to find it there, because of dispersion. To eliminate dispersion from the picture, we fire a group of similar rockets, taking care that we introduce no systematic differences between successive rockets. From the pattern of impact points for this group, we can compute the probable error of the result given by our theory.

In various sections of Chap. III, we have presented different degrees of elaborateness of the theory. The degree of elaborateness to be used in practice depends upon the accuracy desired and upon the characteristics of the rocket. In testing the theory, one must use the theory appropriate to the rocket being used as the subject of the test. For example, if the acceleration of the rocket is violently progressive, one should not in general use the approximation that the acceleration is constant. Of course, if the errors in experimental data are greater than differences in the results of two degrees of elaborateness, the experimenter is free to choose that degree which he wishes to use.

In various experiments that have been performed, discrepancies between theory and experiment have appeared. It is true that only the basic solution of Sec. 1 of this chapter has been used, even for rockets which do not very well meet the assumptions underlying that solution. The use of the basic solution has been necessary, both to save time and because the data needed for a more elaborate solution were not available. Also, in some cases, data needed for the basic solution could not be determined with sufficient accuracy (such as the orientation of the launcher on an airplane with respect to the local air stream).

It is unfortunate that we are not in a position to give actual experimental data. We have to ask the reader to take our word for it that the theory is reasonably well verified by experiment as far as sighting is concerned. The experimental errors involved are large, so that the check is by no means absolute. However, the experiments have been conducted under a wide variety of conditions, and it would be surprising if the agreement found under all these conditions were purely fortuitous. As more accurate basic and experimental data become available, thus allowing more elaborate theory to be used, there is reason to expect that the agreement with experiment should improve.

We now turn to the question of predicting dispersion. Here the conclusions to be drawn are not so clear.

In our basic solution, we have postulated three types of force (or torque) that can cause dispersion, namely, those resulting from non-zero values of L , δ_T , and δ_M . Having postulated these, the technique of solving the equations of motion is the same as that of solving the equations including the effect of gravity, that is, of finding the sight settings. Our solution almost certainly gives the effect of gravity correctly, to the degree of accuracy with which we are concerned; we have, therefore, reason to believe that it also is capable of giving correctly the motion of a rocket, *if* the rocket were subject to constant values of L , δ_T , and δ_M . Our problem is to find if these parameters can represent successfully the principal sources of dispersion of rockets, assuming that the solution based on these parameters is correct.

In the last paragraph, and in the rest of this section, we purposely ignore the dispersion caused by variation in burnt velocity, burning distance, and the like. Dispersion from these sources is the dispersion of a group of slightly different idealized rockets and can be estimated by computing differences in the idealized trajectory caused by small variations in these quantities. This type of dispersion we call "velocity dispersion," although part of it may come from other sources than variations in velocity. Velocity dispersion occurs only along range (or vertically for an upright target). We are going to mean by dispersion the dispersion of a group of actual rockets all represented by the same idealized rocket. This type of dispersion can be separated experimentally from velocity dispersion by considering only the dispersion in a lateral direction. It also has, of course, a vertical component to be combined with the velocity dispersion. In all practice to date, the dispersion due to other sources has been so large that velocity dispersion has been, by comparison, negligible.

One method which might answer our questions about L , δ_T , and δ_M goes somewhat as follows: We fire several rockets and photograph

them during the burning period, with a high-speed camera. From the photographic records, we can measure the angle ϕ as a function of s , the burning distance. (θ and δ cannot be directly measured from the film.) If all our assumptions are correct, ϕ is given as a function of s by, say, the sum of (III.1.28) and (III.1.37). If the rocket is not expected to obey the basic solution, we use the appropriate modification. We know the value of g , and we can make δ_p and ϕ'_p zero by using a zero-length launcher. Thus L , δ_T , and δ_M occur linearly as unknown parameters.

By statistical methods, the values of L , δ_T , and δ_M that give the best fit to the observed curve of ϕ as a function of s can be determined. In addition, σ should be treated as an unknown parameter, to take care of the possibility that jet action may modify the value of K_M , and hence of σ . This has been done for several rounds. In some cases, the results gave values of δ_T and δ_M ranging from 8 to 18°. This is clearly absurd. While the experimental values of ϕ were not too reliable, it was nonetheless obvious that the postulated causes of dispersion were inadequate to explain the motion.

This failure might result from the existence of other unknown sources of dispersion or from large variations in the values of L , δ_T , and δ_M . Trying to take into account changes in our three parameters would introduce so many new parameters that the results could not possibly be significant. For the present, at least, we feel that attempts at a direct test such as this are not likely to be successful.

It is still possible, of course, that the postulation of constant L , δ_T , and δ_M , with no other sources of dispersion, while unable to account for the details of the motion during burning, might still represent the resulting dispersion adequately. Accordingly, we next consider studies of the dispersion of groups of rockets.

It is advisable to simplify the experiments as much as possible by trying to separate the parameters L , δ_T , and δ_M from each other. It turns out that L is the easiest one to separate, because it can be measured. To measure L , we construct a set of scales after the diagram shown in Fig. III.16.1. C is a cone whose axis passes through the knife edge, which is so constructed that the nozzle of the rocket can be accurately aligned upon it. If O , the center of gravity of the rocket, does not lie on the nozzle axis, the balance will swing to one side and can only be restored to the center position by placing the weight R in the proper place. When this is done the nozzle axis is vertical and passes through the knife edge. The distance from the center of gravity to the axis can be computed from the total weight of the rocket and the reading of the weight R . This distance is the component of L

in the plane of the figure. The other component is measured by turning the rocket through 90° about the axis of the cone.

We then fire this rocket, being careful to observe the orientation of L when the rocket is placed in the launcher. For simplicity, it is best to orient the resultant L in a horizontal direction. We take precautions to measure everything we need in solving the equations of

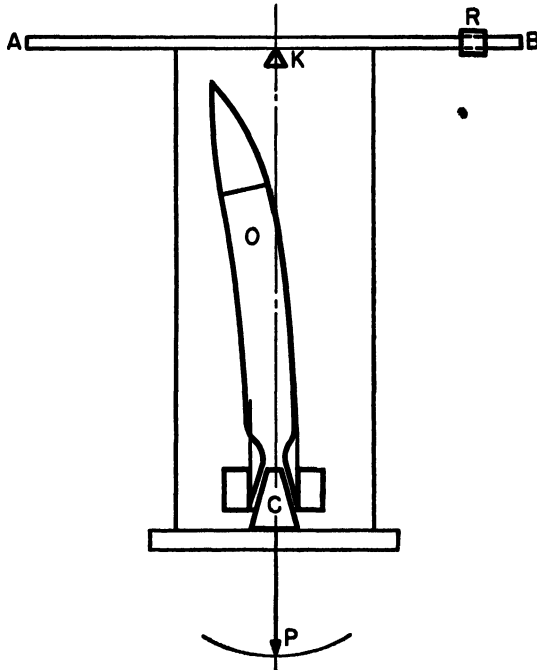

FIG. III.16.1.—Balance for measuring L

- AB = calibrated beam.
- K = knife edge.
- R = weight.
- C = cone to align rocket nozzle.
- P = pointer.
- O = center of gravity of rocket.

motion, such as the acceleration vs. distance function, and the spin, if any. Again, as with testing the solution depending upon gravity, we figure out where the rocket should go and then look for it.

Again, in general, we do not find the rocket at the predicted point. Figure III.16.2 illustrates what usually happens. Figure III.16.2 gives the observed horizontal coordinates of impact as a function of the measured horizontal components of the malalignment L for a group of similar rockets. The rockets had no spin, as determined by photographic records, so that there is no connection between these

and vertical components. Information about the rocket used in this test is still classified, so we cannot describe any characteristics of the round. In fact, just to be safe, we have omitted the scales in Fig. III.16.2.

The solid line gives the predicted points of impact, while the dashed line is the solid line corrected to pass through the center of impact of the rounds. This is, of course, legitimate, since the origin of coordinates was an arbitrary point and was not precisely the true point of aim. In obtaining the predicted value, account was taken of the lift

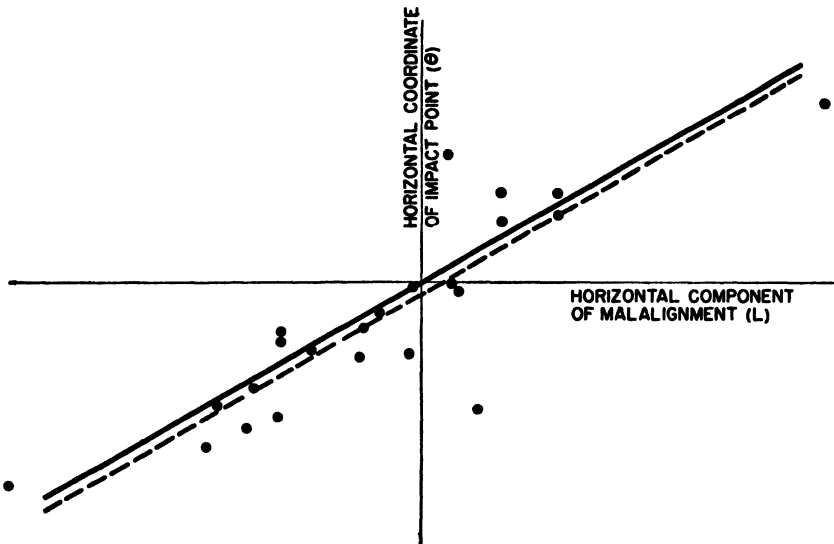

FIG. III.16.2.—Horizontal coordinates of impact points versus horizontal components of malalignment (L). Solid line is theoretical curve. Dashed line is the theoretical line adjusted to pass through the center of impact.

and of the variation in acceleration. The basic solution, in which both of these are ignored, gave values differing by about 20 per cent from the values used.

The experimental points are seen not to lie on the dashed line, but they are pretty randomly scattered about it. This tells us three things. First, the solution must describe with reasonable accuracy the behavior of a rocket with a constant value of L . Second, there are other sources of dispersion whose magnitudes have very little, if any, correlation with the measured values of L . Third, a statistical analysis shows that about two-thirds of the dispersion of this group of rockets is caused by L ; that is, if all the experimental points lay on the theoretical line, so that there were no other sources of dispersion, the dispersion would be reduced by about one-third.

This last conclusion is not necessarily valid for any except the group of rockets tested. Other groups might show quite different relations between the dispersion caused by L and that caused by other sources of dispersion.

We now consider the possibility of dispersion from δ_T and δ_M . Because of the approximate relation (I.5.1), we see that the dispersion due to δ_T is almost sure to be small compared to that due to L . However, there is no necessary relation, even as approximate a one as that between L and δ_T , which connects L and δ_M . We can still form some idea of their relative importance from our numerical examples. In the first example of Sec. 2, an L of 0.050 in. produced a dispersion of 0.049 rad, and a δ_M of 0.01 rad (slightly over 0.5°) produced a dispersion of 0.002 rad. In the second example, the same values of L and δ_M produced dispersion of 0.029 and 0.008 rad, respectively. These do not seem to be unreasonable values of L and δ_M , so we conclude that under some conditions the dispersion due to δ_M is comparable in magnitude to that due to L , and that δ_M must be reckoned as a possible source of dispersion. It must not be forgotten that additional dispersion due to δ_M can arise after burning.

Some rocket ballisticians will disagree with this statement. It is a common belief in this country that substantially all rocket dispersion is L -type dispersion. There is much to be said for this viewpoint. It is based upon an oversimplification which we used in discussing the experimental measurement of L as shown in Fig. III.16.1. There we said that L was the distance from the center of gravity to the axis of the nozzle, as measured by the balance. There are two flaws in this statement. One is that when burning starts the rocket may be distorted by the pressures and heat involved in the burning processes, so that the value of L measured on the balance may not be the actual value during burning. Another is that L is really the distance from the center of gravity to the axis of thrust, not to the axis of the nozzle. Therefore, if the axis of thrust does not coincide with the axis of the nozzle, the measured value of L is not the actual value of L during burning. This type of malalignment, in which the two axes do not coincide, is called "gas malalignment," while the malalignment measured on the balance is called the "mechanical malalignment."

Both these explanations of a possible discrepancy between the mechanical malalignment and the actual malalignment are entitled to belief, and the phenomena they invoke are probably of varying degrees of importance for various types of rockets. A systematic study of the actual torques produced by a rocket motor during burning needs to be carried out. There have been experiments that definitely indicate

TABLE III.16.—SOME DISPERSION TESTS WITH M9 ROCKETS*

Tabular No.	Remarks	Conditions of firing	No. of rounds	σ , ft	Mk^2 , lb ft ²	M , lb	Burnt velocity, ft/sec (relative to launcher)	Burning time, sec	Horizontal dispersion, mils, P.E.
1	Locking folding fins	Ground, 7½ ft tube	20	190	19.1	38.3	860	0.18	17
2	Large fixed fins	Ground, 7½ ft rail	19	160	27.2	43.5	780	0.16	10
3	Large fixed fins	Air, 88 in. rail, 400 ft/sec air speed	28	160	27.2	43.5	780	0.16	8
4	Loose folding fins	Air, 15 ft tube, 381 ft/sec air speed	24	190	19.1	38.3	823	0.18	15
5	Locking folding fins	Air, 15 ft tube, 356 ft/sec air speed	34	190	19.1	38.3	887	0.19	8
6	Locking fins, 4.9 lb of fast-burning powder	Ground, 7½ ft tube	25	190	19.2	38.5	...	33 ft burning distance	5.2
7	Locking fins, 5.3 lb of fast-burning powder	Ground, 7½ ft tube	21	190	19.3	38.9	...	48 ft burning distance	4.6

* The M9 rocket differs from the M8 only in having an inert head rather than a live head. Their ballistic properties are identical.

the presence of gas malalignment, but it has not, we feel, been demonstrated that the gas malalignment is of the size necessary to account for the dispersion in excess of that caused by mechanical malalignment. The technique of these experiments has been such that the values measured for gas malalignment are not very reliable.

If dispersion is L -type dispersion only, one can compute the average value of L for a type of rocket from a dispersion test. If a second test is made under different conditions, one can then predict the dispersion under the new conditions. If this predicted value is confirmed by a test, then one is entitled to conclude that most dispersion is indeed L -type dispersion. For some rockets, this may well be the case. For the M8 rocket, this is not the case, as shown by Table III.16.

Measurements of dispersion are at best very complicated and are difficult to repeat, because of the many factors that enter into determining dispersion. In compiling the above table, we have tried to avoid using any data subject to great doubt on this score. It is just because of this caution that the number of entries in the table is so small. Even with this caution, it is unfair to use the table except to compare tests 1, 2, and 3 with each other, tests 4 and 5 with each other, and tests 6 and 7 with each other. It is not fair to compare, say, test 1 with test 5. These tests are still subject to doubts based upon the number of rounds used.

Consider tests 1, 2, and 3. Let us assume for the moment that all dispersion is of the L type. Using the dispersion in test 1 as the standard, we compute that the dispersions in tests 2 and 3 should be $9\frac{1}{2}$ and 4 mils, respectively. The agreement in test 2 is quite good but that in test 3 is quite poor, 8 mils being the observed dispersion instead of 4 mils. These tests do not support the view that all dispersion is of the L type, but they are quite consistent with the theory that the dispersion is due to a combination of L and δ_M . The dispersion due to δ_M for short-burning rockets fired from the ground is small, so that the two ground tests show principally the effect of L . In air firing, the dispersion due to δ_M is greater for short-burning rockets than it is in ground firing, so that it prevents the dispersion from decreasing as much as the theory based just on L predicts.

Tests 4 and 5 show the existence of δ_M type dispersion quite clearly. The only difference between the rockets used in the two tests is a small detail in the fin assembly. The "loose folding fins" open by virtue of kinetic reaction when the rocket is fired and, after opening, stay open because of air drag. Because of the necessary looseness of construction, it is probable that they can wobble slightly. The "locking folding fins" open in the same manner but are held open and also

tightly fixed by a locking device. The difference in dispersion in tests 4 and 5, which can only be due to changes in the average value of δ_M caused by the locking feature, is quite striking.

We have included tests 6 and 7 as our prize curiosity. In these tests, every effort was made to secure uniformity. The metal components used in both tests were from the same manufacturing lot. Presumably the rounds differed only in the weight and granulation of the powder used. The granulation for the heavier powder charge was chosen so that the chamber pressure was not altered. The powder was all of the same composition and was carefully chosen for uniformity. Rounds for the two tests were stored together and were fired alternately from the same launcher, so that there could have been no systematic differences between conditions of the two tests, except just possibly slight changes for the last four rounds of test 6, for which there were no matching rounds of test 7.

We ignore the second significant figure in the dispersion and say that both tests gave a dispersion of 5 mils. If all the dispersion is of the L type, the dispersion in test 7 should be greater than that in test 6 by a factor of 2; if it is δ_M type, by a factor of 3; and if δ_T type, by about 20 per cent. δ_T type dispersion comes closest to agreeing with the results, but we have already discarded it as a significant source of dispersion for the M8 rocket.

We advocate no particular explanation for the results of tests 6 and 7. It may be one of those 100 to 1 chances that a result obtained statistically differs significantly from the true value. It can also be argued that the results of one experiment should not be stressed too heavily, but the great care taken in this experiment entitles it to respect. It can also be argued that, for some reason, the gas malalignment in the test 7 is much less than in test 6, thus canceling the tendency toward increased dispersion caused by the increased burning distance. This we cannot deny, knowing nothing about the origins of gas malalignment. This explanation seems quite implausible, however.

The conclusion seems inevitable that L -type dispersion alone cannot account for the dispersion of the M8 rocket. This conclusion is not based only upon the meager data in the table above but is also indicated by many other tests which we did not include, because individually they may not be reliable. Considered together, though, with due allowances for uncontrolled conditions of experiment, they constitute fairly strong evidence. Further, it must be considered as possible that the joint postulation of L , δ_T , and δ_M is incapable of explaining entirely observed rocket dispersion.

These conclusions can be applied only to the M8 rocket and its

counterpart, the M9. It may well be that the dispersion of other rockets is adequately explained. The real danger (and pointing out this danger is the actual purpose of this section) is that conclusions drawn from one type of rocket may be applied uncritically to all types of rockets. We believe that this is what happened in connection with the gas malalignment theory. We cannot believe that the original propounders of this theory believed that it should be applied to all types of rockets, differing greatly in design from each other. However, the theory was accepted widely and uncritically and applied uncritically to situations for which it was not proved correct. In view of the complexity of rocket processes and greatly differing features of various designs, it must be regarded as extremely fortunate if we could get an adequate explanation of rocket dispersion on the basis of the single parameter L .

It should not be inferred that the theory of exclusive L -type dispersion does not have its uses. Under the pressure of the military emergency, it was necessary to have quickly a theory which could furnish design criteria and which could be easily applied. Such a theory, even though approximate, is better than a more general theory which cannot be used because there is not time to gather the necessary basic data. The gas malalignment theory or theory of L -type dispersion was such a theory and became widely used.

To summarize, the solution of the equations of motion given in this chapter represents reasonably well the behavior of a rocket which is subject to the postulated phenomena. In particular, the theory can be used for the computation of sighting tables. In accounting for rocket dispersion, the postulated force system is sometimes adequate and sometimes not, depending upon design and conditions of use. Much thorough work remains to be done before the theory of dispersion can be placed on a solid foundation.

CHAPTER IV

BOUNDARY CONDITIONS

The final step that remains in solving for the motion of a rocket is the determination of the boundary conditions for use in the previous chapter. These are several in number, the most useful being those needed to determine θ , namely, θ_p , δ_p , and ϕ'_p . These are also the most difficult to determine, since the others, such as x and y , are usually obvious from the geometry of the situation. In some cases, the value of ψ_p will be in doubt. For example, unaccountable spins of as much as a quarter turn during launching have sometimes been observed in launching a rocket through a tube. Until an explanation of this phenomenon is forthcoming, we have no choice but to ignore it and assume zero spin during launching except in those obvious cases where a rocket is deliberately given a spin during launching. In such cases, we assume that the desired amount of spin is attained.

For the purpose of determining conditions at the end of the launcher, we define the end of the launcher to be the position of the center of gravity when the rocket is first completely free of all constraints due to the launcher. Thus, if the front end of the rocket disconnects from the launcher before the rear end of the rocket, then the position of the center of gravity when the rear end disconnects is taken to be the end of the launcher.

It might be supposed that one would have $\delta_p = 0$ and $\phi'_p = 0$ for the standard rocket. Not so. If the launcher and the air are in relative motion, one will usually have δ_p different from zero for the standard rocket. Details are given in Sec. 1 below. Also there are types of launchers for which ϕ'_p is not zero for the standard rocket. To see how this can be, recall that a standard rocket is subject to gravity; when the center of gravity passes the end of the launcher or when part of the support from the launcher has been removed, the weight of the rocket tends to make the center of gravity fall. The launcher is still supporting the rear of the rocket and so sets up a torque which tends to rotate the rocket about a horizontal axis. Thus, by the time the rocket is completely free of constraints, it has turned a little and acquired an angular velocity. This effect is called the "tipping-off" effect. It is usually true that the angular velocity

produces greater effects upon the trajectory than does the actual angle through which the rocket turns during launching.

The amount of tip-off depends upon the flexibility of the launcher. This is shown in detail in Sec. 2 below. In case the launcher is noticeably flexible, the formulas given below for a flexible launcher are of little actual value for determining the launching conditions because of the difficulty of determining certain physical constants of the launcher. Nevertheless, we give the formulas for a flexible launcher because they show the undesirability of having the launcher flexible. In any practical application, care should be taken to ensure rigidity of the launcher to avoid the unpleasant effects of launcher flexibility. For a rigid launcher, our formulas give the launching conditions with adequate accuracy.

Since the rocket is seldom moving very fast during launching, the aerodynamic effects are likely to be small. It is customary to ignore them completely.

For a nonstandard rocket with L , δ_T , and δ_M different from zero, the launching conditions, mainly θ_p , δ_p , and ϕ'_p , will differ from those for the standard rocket. These differences will be responsible for a portion of the final dispersion [see (III.1.11)]. This portion of the final dispersion is the latent dispersion at launching.

In this chapter, we abandon our convention that θ , ϕ , δ , L , and δ_T are complex quantities. Instead, we take them to be real, and treat the motions in the vertical and horizontal planes separately.

1. Launcher Velocity

Let v_a (see Fig. IV.1.1) denote the velocity of the launcher relative to the air at the instant of launching, and let v_{pr} denote the velocity

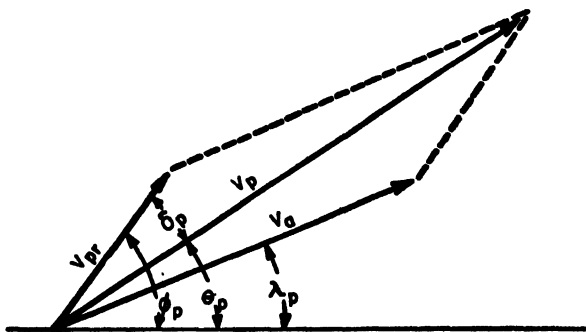

FIG. IV.1.1.—Boundary conditions resulting from a launcher velocity.

of the rocket relative to the launcher at the same time. Then, v_p , the velocity of the rocket relative to the air at launching, is the vector

sum of v_a and v_{pr} . From Fig. IV.1.1 we see that if we assume no tipping-off, so that v_{pr} is the direction of the rocket axis, then δ_p is the angle between v_p and v_{pr} , ϕ_p is the angle between v_{pr} and the x axis, λ_p is the angle between v_a and the x axis, and θ_p is $\phi_p - \delta_p$. If $\phi_p - \lambda_p$ is small, we can write the approximate relations

$$\begin{aligned}(\theta_p - \lambda_p)(v_{pr} + v_a) &= v_{pr}(\phi_p - \lambda_p) \\ \delta_p(v_{pr} + v_a) &= v_a(\phi_p - \lambda_p)\end{aligned}$$

From these we deduce

$$\theta_p = \lambda_p + \frac{v_{pr}}{v_{pr} + v_a} (\phi_p - \lambda_p) = \frac{v_a \lambda_p + v_{pr} \phi_p}{v_a + v_{pr}} \quad (\text{IV.1.1})$$

$$\delta_p = \frac{v_a}{v_{pr} + v_a} (\phi_p - \lambda_p) \quad (\text{IV.1.2})$$

The approximation is valid whenever δ_p and the difference $\phi_p - \lambda_p$ are both small, there being no restriction on the size of either ϕ_p or λ_p taken separately.

The two important cases in which we need these results are for ground firing in a cross-range wind, and for firing from an airplane if the launcher is not pointed along the line of flight. Usually in the former case only a horizontal component of launcher velocity is important. In the latter case, both a lateral and a vertical component of launcher velocity may be important.

In the case of ground firing in a cross-range wind, we find it convenient to use different coordinate systems XYZ and xyz , fixed relative to the ground and to the air, respectively, which coincide at $t = 0$. If the wind velocity is horizontal, the Y and y values (both being vertical) will be the same, and we need consider only the other coordinates. We first find the motion relative to the air during burning, using the values of θ_p and δ_p given by Fig. IV.1.1. It is assumed that Fig. IV.1.1 moves with the air, so that v_a is the velocity of the launcher relative to the air. We use the results of Chap. III to locate the rocket at the end of burning in the xyz system and then locate it in the XYZ system by the transformation

$$X = x + w_x t \quad Y = y \quad Z = z + w_z t \quad (\text{IV.1.3})$$

in which w_x and w_z are the components of the wind velocity in the positive x and z directions, respectively.

In general, the effect of a side wind blowing across the launcher is to turn the rocket into the wind. The reason is obvious if one considers the following sequence of events: When the rocket emerges from the restraint of the launcher, the wind acts more strongly on the

fins than on the rest of the rocket. Thus the fins are blown downwind. The rocket is thus pointed upwind a bit and so is pushed somewhat upwind by the thrust of the jet.

In the case of firing from an airplane, we use the same analysis in transforming from air-fixed to ground-fixed coordinates if there is a wind relative to the ground. Even if there is no wind relative to the ground, there is still a velocity of the launcher relative to the air, and we must draw a figure corresponding to Fig. IV.1.1 for both the horizontal and vertical planes. In this case, we would find it convenient to take the vertical plane as containing the velocity of the airplane. Then, in the vertical plane, $-\lambda_p$ would be the dive angle of the airplane and $\phi_p - \lambda_p$ the elevation of the launcher above the flight line.

It is also possible, in the case of firing from an airplane, for the motion of the launcher to give rise to a value of ϕ'_p as well as of δ_p . This would happen in case the airplane were performing a turning maneuver at the time of launching.

A numerical example is easily conceived. Let us have an airplane in a 12° dive, going 500 ft/sec. Let the launcher be elevated 3° above the flight line of the plane. Let the launching velocity be 300 ft/sec. Then

$$\begin{aligned}v_a &= 500 \\v_{pr} &= 300 \\ \lambda_p &= -12^\circ \\ \phi_p - \lambda_p &= 3^\circ\end{aligned}$$

So, by (IV.1.1) and (IV.1.2),

$$\begin{aligned}\theta_p &= -12^\circ + \frac{300}{300 + 500} 3^\circ \\ &= -10\frac{7}{8}^\circ \\ \delta_p &= \frac{500}{300 + 500} 3^\circ \\ &= 1\frac{7}{8}^\circ\end{aligned}$$

2. Tipping-off Effects

We distinguish two main types of rocket and launcher construction. We designate these types as "fixed support" and "moving support," with "fixed" and "moving" being taken relative to the launcher. The types of construction which give rise to each type of support will be indicated in the discussion of each type.

In solving for the motion during launching, we shall assume that G , the acceleration of the rocket due to the jet, is constant. We shall

neglect jet damping and assume that the rocket does not spin fast enough during launching to cause gyroscopic effects or to change the orientation of L or δ_r appreciably during tipping-off.

There is one type of construction in which the constraints due to the launcher are removed immediately upon firing, namely, the so-called "zero-length launcher." In this construction, the rocket is suspended by two hooks from two eyes and is so arranged that it is freed from both supports simultaneously after traveling perhaps an inch, which is an entirely negligible distance.

Moving Support.—In this type, the point of contact between the rocket and launcher is a fixed point on the rocket. This will be the case in firing a rocket suspended from a slotted rail by means of lugs

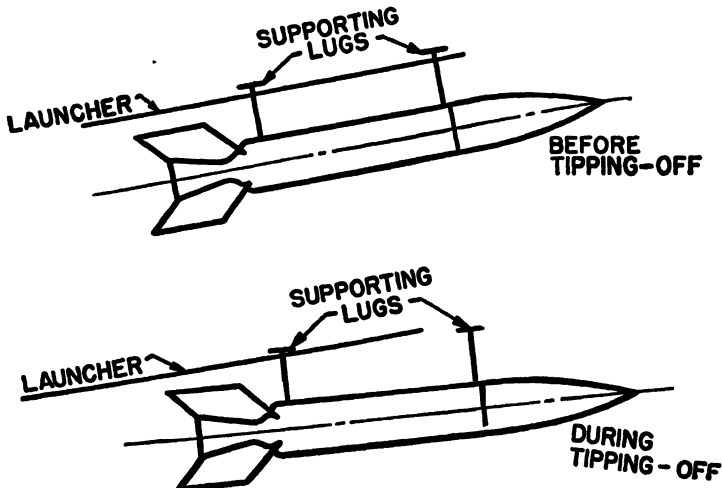

FIG. IV.2.1.—Tipping-off of a rocket supported by two lugs from a slotted rail.

(see Fig. IV.2.1), and also with firing from tubes if the rocket has a large diameter near the head and near the tail, with a smaller diameter between.

We find it convenient to abandon our previous coordinate system and use instead the system shown in Fig. IV.2.2. The x and y axes are fixed relative to the launcher. The origin of xy is the location of the center of gravity when the front lug drops off the launcher. The origin of time is taken at the time of the same event. ϕ is the angle between the rocket axis and the launcher and is positive if measured counterclockwise; q is the distance from the center of gravity to the cross section of the rocket containing the point of support; and r is the distance from the point of support to the rocket axis, taken positive if the support is above the center line.

Making the customary approximations for small values of ϕ and δ_r , the equations of motion are

$$T - MR_x - Mg \sin \phi_0 = M\ddot{x} \tag{IV.2.1}$$

$$T(\phi - \delta_r) + MR_y - Mg \cos \phi_0 = M\ddot{y} \tag{IV.2.2}$$

$$-MR_y q + MR_x r + TL = I\ddot{\phi} \tag{IV.2.3}$$

where x and y are the coordinates of the center of gravity and MR_x and MR_y are the components of the force exerted by the launcher in the negative x and the positive y directions, respectively. In addition,

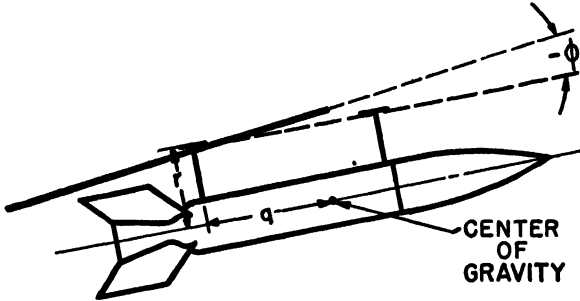

FIG. IV.2.2.—Coordinate system for tipping-off rocket, moving support. x -axis parallel to launcher. y -axis perpendicular to launcher. Launcher makes angle of ϕ_0 with horizontal.

there is the condition of constraint. For a rigid launcher, this takes the form that the y coordinate of the point of support shall not change:

$$y - q\phi = 0 \tag{IV.2.4}$$

There is also the definition of the “coefficient of friction”:

$$\mu = \frac{R_x}{R_y} \tag{IV.2.5}$$

In some cases, this coefficient of friction may be quite large, for example, if a lug binds on the launching rail. By combining (IV.2.5), (IV.2.4), (IV.2.3), and (IV.2.2), the following differential equation is obtained for ϕ :

$$\ddot{\phi} - \frac{G(q - \mu r)}{k^2 + q^2 - \mu r q} \phi = \frac{GL - (q - \mu r)(g \cos \phi_0 + G\delta_r)}{k^2 + q^2 - \mu r q}$$

It is easily verified that the solution of this which satisfies the boundary conditions that $\phi = \dot{\phi} = 0$ when $t = 0$ is

$$\phi = \left(\frac{g \cos \phi_0}{G} + \delta_r - \frac{L}{q - \mu r} \right) (1 - \cosh \omega t) \tag{IV.2.6}$$

$$\dot{\phi} = -\omega \left(\frac{g \cos \phi_0}{G} + \delta_r - \frac{L}{q - \mu r} \right) \sinh \omega t \tag{IV.2.7}$$

in which

$$\omega^2 = \frac{G(q - \mu r)}{k^2 + q^2 - \mu q r}$$

From the form of the coefficients of the hyperbolic functions in these equations, it is seen that gravity, L , and δr can be considered separately in these boundary conditions, as well as in the equations of motion during burning. The time is computed by solving (IV.2.1), in which it is probably valid to neglect MR_x or to assume a constant value for it.

If ωt is small, $\cosh \omega t$ can be replaced by $1 + \omega^2 t^2/2$, and $\sinh \omega t$ by ωt , in (IV.2.6) and (IV.2.7). Physically, this amounts to neglecting the term $T\phi$ in (IV.2.2).

To obtain the values of ϕ and $\dot{\phi}$ in the horizontal plane through the launcher, we need only set $g = 0$ in (IV.2.6) and (IV.2.7).

In writing (IV.2.4), we have assumed that the launcher is perfectly rigid. If there is flexibility of the launcher, the point of support will not move with a constant y coordinate. If we assume that the deflection of the point of support is proportional to the force exerted on it and that the time required for the support to take up a deflection is small compared with the duration of the events in which we are interested, we can write in place of (IV.2.4) the following:

$$y - q\phi = - (R_v - R_0) \frac{M}{E} \quad (\text{IV.2.8})$$

where E is the force required to produce unit deflection of the launcher and R_0 is the initial value of R_v . R_0 can be computed by finding the force exerted by the rear support just before the front support quits contact with the launcher and noting that the value of R_v must be continuous. For example, if the two supports are equally spaced about the center of gravity, $R_0 = [(g \cos \phi_0 + G\delta r) + (GL/q)]/2$. The minus sign occurs in (IV.2.8) because MR_v is the force exerted by the launcher, not on it. Using (IV.2.8) instead of (IV.2.4), we obtain as a differential equation for ϕ

$$\begin{aligned} -\frac{Mk^2}{E} \frac{d^4\phi}{dt^4} - (k^2 + q^2 - \mu r q) \frac{d^2\phi}{dt^2} + (q - \mu r) G\phi \\ = (q - \mu r)(g \cos \phi_0 + G\delta r) - GL \end{aligned} \quad (\text{IV.2.9})$$

This equation has the boundary conditions that at $t = 0$,

$$\begin{aligned} \phi = \frac{d\phi}{dt} = \frac{d^3\phi}{dt^3} = 0 \\ \frac{d^2\phi}{dt^2} = \frac{GL - R_0(q - \mu r)}{k^2} \end{aligned}$$

It can be verified that the solution of (IV.2.9) satisfying the boundary conditions is

$$\phi = \left(\frac{g \cos \phi_0}{G} + \delta_T - \frac{L}{q - \mu r} \right) \left(1 - \frac{\lambda_2^2}{\lambda_1^2 + \lambda_2^2} \cos \lambda_1 t - \frac{\lambda_1^2}{\lambda_1^2 + \lambda_2^2} \cosh \lambda_2 t \right) + \frac{GL - R_0(q - \mu r)}{k^2(\lambda_1^2 + \lambda_2^2)} (\cosh \lambda_2 t - \cos \lambda_1 t) \quad (IV.2.10)$$

whence

$$\phi = \left(\frac{g \cos \phi_0}{G} + \delta_T - \frac{L}{q - \mu r} \right) \left(\frac{\lambda_1 \lambda_2^2}{\lambda_1^2 + \lambda_2^2} \sin \lambda_1 t - \frac{\lambda_2 \lambda_1^2}{\lambda_1^2 + \lambda_2^2} \sinh \lambda_2 t \right) + \frac{GL - R_0(q - \mu r)}{(\lambda_1^2 + \lambda_2^2)k^2} (\lambda_2 \sinh \lambda_2 t + \lambda_1 \sin \lambda_1 t) \quad (IV.2.11)$$

where

$$\lambda_1^2 = \frac{(k^2 + q^2 - \mu r q) + \sqrt{(k^2 + q^2 - \mu r q)^2 + [4Mk^2(q - \mu r)G/E]}}{2Mk^2/E}$$

$$\cong \frac{(k^2 + q^2 - \mu r q)E}{Mk^2}, \quad E \text{ large}$$

$$\lambda_2^2 = \frac{(k^2 + q^2 - \mu r q) - \sqrt{(k^2 + q^2 - \mu r q)^2 + [4Mk^2(q - \mu r)G/E]}}{-2Mk^2/E}$$

$$\cong \frac{(q - \mu r)G}{k^2 + q^2 - \mu r q}, \quad E \text{ large}$$

We obtain the solution for a rigid launcher by letting E approach infinity.

As an example, let us take approximate values for a rocket fired from a 7.5 ft rail, being suspended from the rail by two lugs spaced 2 ft apart at equal distances from the center of gravity. We shall assume $k^2 = 0.56 \text{ ft}^2$, $q = 1 \text{ ft}$, $\mu = 1$, $r = 0.5 \text{ ft}$, $G = 5,160 \text{ ft/sec}^2$, and $M = 35 \text{ lb}$. If we denote by ϕ_T that part of ϕ which involves δ_T , by ϕ_g the part involving g , and by ϕ_L the part involving L , we obtain at the end of the launcher the values given in Table IV.2 which, when corrected for the value ϕ_0 , become the boundary conditions to use in Chap. III.

TABLE IV.2.—VALUES OF ϕ AND $\dot{\phi}$ FOR AN M8 ROCKET FIRED FROM RAILS

E , lbs/ft	$\phi_0/\cos \phi_0$, rad	ϕ_T/δ_T , rad/rad	ϕ_L/L , rad/ft	$\dot{\phi}_g/\cos \phi_0$, rad/sec	$\dot{\phi}_T/\delta_T$, sec ⁻¹	$\dot{\phi}_L/L$, (rad/sec)/ft
0	-0.000469	-0.0752	0.1504	-0.134	-21.5	43.0
10 ⁴	-0.000468	-0.0751	0.1502	-0.134	-21.5	43.0
10 ⁵	-0.000467	-0.0749	0.1497	-0.133	-21.3	42.6
10 ⁶	-0.000455	-0.0722	0.1443	-0.125	-19.8	39.6
∞	-0.000376	-0.0603	0.1206	-0.108	-17.4	34.8

This theory is open to two serious criticisms. Since most launching devices are built in the shape of a beam supported near its ends, the force per unit deflection depends upon the position of the force, so that E is a complicated function of x . Also, particularly for low values of E , the time required for the launcher to assume its equilibrium position under an applied force may be appreciable; in fact, the launcher will be expected to execute oscillations, which will certainly have some effect upon the motion of the rocket.

We can perhaps get some idea of the effect of oscillations of the launcher by making still a third assumption concerning the motion of the point of support, which will be that this point oscillates in the y direction with a period characteristic of the launcher. We take, therefore,

$$y - q\phi = -A \cos \lambda t \quad (\text{IV.2.12})$$

We will have to assume a value of A , for want of any information on the subject. Proceeding as before, we find as a differential equation for ϕ

$$\begin{aligned} \ddot{\phi} - \frac{G(q - \mu r)}{k^2 + q^2 - \mu r q} \phi &= -\lambda^2 A \frac{q - \mu r}{k^2 + q^2 - \mu r q} \cos \lambda t \\ &\quad - \frac{G(q - \mu r)}{k^2 + q^2 - \mu r q} \left(\frac{g \cos \phi_0}{G} + \delta r - \frac{L}{q - \mu r} \right) \end{aligned}$$

The solution of this equation which satisfies the condition that $\phi = 0$ and $\dot{\phi} = 0$ at $t = 0$ is

$$\begin{aligned} \phi &= \frac{\lambda^2}{\lambda^2 + \omega^2} \frac{q - \mu r}{k^2 + q^2 - \mu r q} A (\cos \lambda t - \cosh \omega t) \\ &\quad + \left(\frac{g \cos \phi_0}{G} + \delta r - \frac{L}{q - \mu r} \right) (1 - \cosh \omega t) \quad (\text{IV.2.13}) \end{aligned}$$

and

$$\begin{aligned} \phi &= -\frac{\lambda^2}{\lambda^2 + \omega^2} \frac{q - \mu r}{k^2 + q^2 - \mu r q} A (\lambda \sin \lambda t + \omega \sinh \omega t) \\ &\quad - \left(\frac{g \cos \phi_0}{G} + \delta r - \frac{L}{q - \mu r} \right) \omega \sinh \omega t \quad (\text{IV.2.14}) \end{aligned}$$

in which ω has the same value as in (IV.2.6) and (IV.2.7). The second term of each of these expressions is just the solution in the case of the perfectly rigid launcher, given in (IV.2.6) and (IV.2.7).

We shall consider only the value of ϕ , since it produces a more important effect upon the trajectory than does the value of $\dot{\phi}$ in the cases that we have considered. For the rocket used in computing Table IV.2, $(q - \mu r)/(k^2 + q^2 - \mu r q) = 0.47 \text{ ft}^{-1}$, $\omega = 49.3 \text{ sec}^{-1}$, and

when the rear lug leaves the rail $t = 0.007$ sec, approximately. Suppose that λ has such a value that $0.007\lambda = \pi/2$, so that the end of the launcher is passing through its equilibrium value with an upward velocity as the rear lug leaves. Considering just the part of ϕ due to g , by way of illustration, we find that $\phi = -0.108 \cos \phi_0 - 114A$. If A is 10^{-3} ft and $\phi_0 = 0^\circ$, then $\phi = -0.222$, so that the tipping-off effect is doubled by an oscillation of this particular frequency and amplitude. On the other hand, if the launcher is moving downward as the rear lug leaves, or $\lambda t = 3\pi/2$, and the oscillation has the same amplitude, $\phi = +0.008$.

Thus it would appear possible to eliminate tip-off by a proper choice of frequency and amplitude of launcher oscillations. This way of eliminating tip-off is not recommended, however, since the effect might be completely reversed with a different rocket acceleration, which could easily be caused by changes of temperature. It seems much more desirable to keep the amplitude of any oscillations low, by stiffening the launcher, and thus eliminate the first term in (IV.2.14).

Fixed Support.—In this type, the point of contact between the rocket and launcher is a fixed point of the launcher, in particular, its end. This will be the case in firing a rocket from a tube or trough, if the rocket has constant cross section over most of its length, so that the nose of the rocket tends to dip as the rocket slides out the end of the launcher (see Fig. IV.2.3). It may be that L has the proper

**FOLDING FINS WHICH OPEN
WHEN ROCKET LEAVES LAUNCHER.**

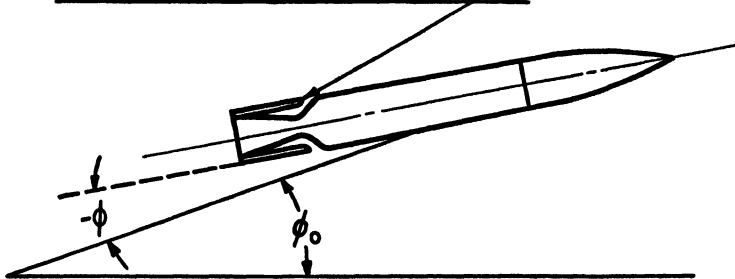

FIG. IV.2.3.—Coordinate system for tipping-off rocket, fixed support. x -axis parallel to launcher. y -axis perpendicular to launcher. Radius of rocket is r .

size and direction to make the nose of the rocket lift. In this case, the point of the rocket that remains in contact is the rear, in which case we have a moving support and return to the previously considered case.

We use the coordinate system of Fig. IV.2.3. The origin of xy is the position of the center of gravity as the center of gravity passes the

end of the launcher. The origin of time is taken at the time of the same event. ϕ is the angle between the rocket axis and the launcher and is positive if measured counterclockwise. The equations of motion for this system can be solved conveniently in only two special cases. One is the perfectly flexible launcher, for which R_y always remains the same for any finite displacement. The other is the perfectly rigid launcher, for which the point at the end of the launcher remains fixed under any finite load. For the former, equating moments about the center of mass to the derivative of angular momentum about that point,

$$I\ddot{\phi} = TL - MR_yx - MR_xr \tag{IV.2.15}$$

However, $R_x = \mu R_y$, and R_y always remains equal to $(g \cos \phi_0 + G\delta_T)$, which was its value as the center of gravity passed the end of the launcher.¹ Hence,

$$I\ddot{\phi} = TL - M(g \cos \phi_0 + G\delta_T)(x + \mu r)$$

Since x is a known function of t from (IV.2.1), which still holds here, this equation can be integrated immediately, giving

$$\phi = \frac{GL}{2k^2} t^2 - \frac{g \cos \phi_0 + G\delta_T}{k^2} \int_0^t \int_0^t (x + \mu r) dt dt \tag{IV.2.16}$$

In the case of the rigid launcher, it is more convenient to choose the end of the launcher as the reference point for computing moments. The thrust contributes a moment of amount $-T(r - L) - T\delta_Tx$, where r is the radius of the rocket. Gravity contributes

$$Mg(r \sin \phi_0 - x \cos \phi_0)$$

The angular momentum about this point is $M(k^2 + x^2 + r^2)\dot{\phi} - M\dot{x}r$, where k is the radius of gyration about the center of gravity. Hence

$$M \frac{d}{dt} [(k^2 + x^2 + r^2)\dot{\phi} - \dot{x}r] = -T(r - L) - T\delta_Tx - Mg \cos \phi_0 x + Mg \sin \phi_0 r$$

or

$$\frac{d}{dt} [(k^2 + x^2 + r^2)\dot{\phi}] = -(G\delta_T + g \cos \phi_0)x + GL - rR_x \tag{IV.2.17}$$

¹ This is not quite correct if L is positive, since in this case the launcher must exert force at more than one point, or if at only one point, this point is at the rear of the rocket. As mentioned before, this would make the problem one involving a moving support.

by substituting for \ddot{x} from (IV.2.1). Integrating once,

$$\phi = \frac{-(G\delta_r + g \cos \phi_0)}{k^2 + x^2 + r^2} \int_0^t x dt + \frac{GL}{k^2 + x^2 + r^2} t - \frac{r}{k^2 + x^2 + r^2} \int_0^t R_x dt$$

A second integration yields ϕ . As the form of x from (IV.2.1) is a bit complicated, it is most convenient to perform this integration approximately in any special case.

As a numerical example, let us take the same rocket as before, for which $k^2 = 0.56 \text{ ft}^2$, $G = 5,160 \text{ ft/sec}^2$, and $M = 35 \text{ lb}$, fired from a 7.5-ft tube. This time, let $\mu = 0$. The center of gravity of this round is about 1.5 ft in front of the tail. For the perfectly flexible launcher, we find

$$\begin{aligned}\phi &= 0.150L - 0.000805 \cos \phi_0 - 0.1291\delta_r \\ \phi &= 52.5L - 0.364 \cos \phi_0 - 58.4\delta_r\end{aligned}$$

and for the perfectly rigid launcher,

$$\begin{aligned}\phi &= 0.0535L - 0.000125 \cos \phi_0 - 0.0201\delta_r \\ \phi &= 8.19L - 0.0689 \cos \phi_0 - 11.06\delta_r\end{aligned}$$

Upon comparing these results with those in Table IV.2 for a moving support, we find that the effects are of the same order of magnitude. We also notice that rigidity is very important with the fixed type of support. It is also important with the moving support in the case that oscillations of the launcher produce significant effects.

Another effect of the launcher upon the rocket exists in firing from tubes. If the rocket is spinning in the tube, it tends to roll up the wall of the tube. If the back part of the rocket is rolling around the tube after the center of gravity has passed the end of the tube, it seems quite plausible that the rocket will be given an angular velocity about a transverse axis. It is to this effect that most of the dispersion of spinning rockets is attributed; however, even with supposedly non-spinning rockets, there is evidence in some cases that rockets have gone through appreciable axial rotation while traversing the launcher, and it seems quite plausible that in such cases an appreciable transverse angular velocity can be given to the rocket. The best way to eliminate such effects in firing from tubes is to use well-polished tubes.

CHAPTER V

PROPERTIES OF THE ROCKET FUNCTIONS

1. Notation and Definition of the Functions

We shall denote the functions by $rc(w)$, $rr(w)$, $rj(w)$, $ic(w)$, $ir(w)$, $ij(w)$, $ra^2(w)$, $rt(w)$, and $ra(w)$. The first letters, r and i , refer to "rocket" and "integral," respectively. The second letters, c , r , and j , indicate a complex function, the real part, and the imaginary part, and we shall use j for the square root of minus one, so that

$$j^2 = -1 \tag{V.1.1}$$

The ideas of absolute value and inverse tangent are suggested by the letters a and t .

We define

$$rc(w) = je^{iw} \int_w^\infty \frac{e^{-ix}}{\sqrt{x}} dx \tag{V.1.2}$$

for nonnegative real w and, writing $rc(w)$ as the sum of its real and imaginary parts,

$$rc(w) = rr(w) + j rj(w) \tag{V.1.3}$$

we get

$$rr(w) = \cos w \int_w^\infty \frac{\sin x}{\sqrt{x}} dx - \sin w \int_w^\infty \frac{\cos x}{\sqrt{x}} dx \tag{V.1.4}$$

$$rj(w) = \cos w \int_w^\infty \frac{\cos x}{\sqrt{x}} dx + \sin w \int_w^\infty \frac{\sin x}{\sqrt{x}} dx \tag{V.1.5}$$

We let

$$ic(w) = \int_0^w \frac{rc(x)}{\sqrt{x}} dx \tag{V.1.6}$$

$$ic(w) = ir(w) + j ij(w) \tag{V.1.7}$$

and find:

$$ir(w) = \int_0^w \frac{rr(x)}{\sqrt{x}} dx \tag{V.1.8}$$

$$ij(w) = \int_0^w \frac{rj(x)}{\sqrt{x}} dx \tag{V.1.9}$$

We take

$$ra^2(w) = [rr(w)]^2 + [rj(w)]^2 = rr^2(w) + rj^2(w) \tag{V.1.10}$$

$$ra(w) = + \sqrt{ra^2(w)} = |rc(w)| \tag{V.1.11}$$

$$rt(w) = \arctan \frac{rj(w)}{rr(w)} \tag{V.1.12}$$

In the last of these we choose that value of the angle which lies between 0 and $\pi/2$. We have

$$rc(w) = ra(w)e^{jrt(w)} \quad (\text{V.1.13})$$

$$rr(w) = ra(w) \cos rt(w) \quad (\text{V.1.14})$$

$$rj(w) = ra(w) \sin rt(w) \quad (\text{V.1.15})$$

In Sec. V.2 we shall prove the relation

$$ij(w) = \frac{\pi}{2} - \frac{1}{2}ra^2(w) \quad (\text{V.1.16})$$

Thus either of $ij(w)$ and $ra^2(w)$ is equally convenient to compute. In the equations for the complex functions we shall favor $ij(w)$ because of brevity, but in the equations for the components we shall prefer $ra^2(w)$ because of greater usefulness in applications.

With the help of the definite integrals

$$\int_0^\infty \frac{\cos x}{\sqrt{x}} dx = \int_0^\infty \frac{\sin x}{\sqrt{x}} dx = \sqrt{\frac{\pi}{2}} \quad (\text{V.1.17})$$

we find, from (V.1.4) and (V.1.5),

$$rr(0) = rj(0) = \sqrt{\frac{\pi}{2}} \quad (\text{V.1.18})$$

From the definitions of the functions there is no difficulty in verifying the values

$$rc(0) = (1 + j) \sqrt{\frac{\pi}{2}} \quad (\text{V.1.19})$$

$$ra^2(0) = \pi \quad (\text{V.1.20})$$

$$ra(0) = \sqrt{\pi} \quad (\text{V.1.21})$$

$$rt(0) = \frac{\pi}{4} \quad (\text{V.1.22})$$

$$ir(0) = ij(0) = ic(0) = 0 \quad (\text{V.1.23})$$

Integration by parts gives

$$\int_w^\infty \frac{e^{-ix}}{\sqrt{x}} dx = -j \frac{e^{-iw}}{\sqrt{w}} + \frac{j}{2} \int_w^\infty \frac{e^{-ix}}{x^{\frac{3}{2}}} dx$$

Multiplication by je^{iw} and use of (V.1.2) results in

$$rc(w) = \frac{1}{\sqrt{w}} - \frac{1}{2} e^{iw} \int_w^\infty \frac{e^{-ix}}{x^{\frac{3}{2}}} dx$$

from which we get

$$ra(w) = |rc(w)| \leq \frac{1}{\sqrt{w}} + \frac{1}{2} \int_w^\infty \frac{dx}{x^4} = \frac{2}{\sqrt{w}}$$

$$\lim_{w \rightarrow \infty} ra(w) = 0 \quad (\text{V.1.24})$$

2. Derivatives of the Functions

Differentiation of (V.1.2), (V.1.4), (V.1.5), (V.1.6), (V.1.8), and (V.1.9) with respect to w gives

$$\frac{d}{dw} rc(w) = jrc(w) - \frac{j}{\sqrt{w}} \quad (\text{V.2.1})$$

$$\frac{d}{dw} rr(w) = -rj(w) \quad (\text{V.2.2})$$

$$\frac{d}{dw} rj(w) = rr(w) - \frac{1}{\sqrt{w}} \quad (\text{V.2.3})$$

$$\frac{d}{dw} ic(w) = \frac{rc(w)}{\sqrt{w}} \quad (\text{V.2.4})$$

$$\frac{d}{dw} ir(w) = \frac{rr(w)}{\sqrt{w}} \quad (\text{V.2.5})$$

$$\frac{d}{dw} ij(w) = \frac{rj(w)}{\sqrt{w}} \quad (\text{V.2.6})$$

From these, by differentiation of (V.1.10), (V.1.11), and (V.1.12) with respect to w , we get

$$\frac{d}{dw} ra^2(w) = -\frac{2rj(w)}{\sqrt{w}} \quad (\text{V.2.7})$$

$$\frac{d}{dw} ra(w) = -\frac{rj(w)}{\sqrt{w} ra(w)} = -\frac{\sin rt(w)}{\sqrt{w}} \quad (\text{V.2.8})$$

$$\frac{d}{dw} rt(w) = 1 - \frac{rr(w)}{\sqrt{w} ra^2(w)} = 1 - \frac{\cos rt(w)}{\sqrt{w} ra(w)} \quad (\text{V.2.9})$$

For the proof of (V.1.16) we see that both members have the same derivative by (V.2.6) and (V.2.7) and have the same value for $w = 0$ by (V.1.20) and (V.1.23).

3. Integrals That Can Be Verified by Differentiation

Except for the constant term, the following integrals can be checked by differentiation of both sides with respect to w . To check the constant term, we put $w = 0$ for integrals from 0 to w and let w approach infinity for integrals from w to ∞ .

Because we do not concern ourselves with negative values of the argument for the functions, the formulas are not to be used for negative values of k .

$$\int_0^w \frac{e^{-ix}}{\sqrt{x}} dx = j rc(w) e^{-iw} + (1-j) \sqrt{\frac{\pi}{2}} \quad (\text{V.3.1})$$

$$\int_0^w \frac{\cos(x-a)}{\sqrt{x}} dx = ra(w) \sin[w - rt(w) - a] + \sqrt{\pi} \sin\left(a + \frac{\pi}{4}\right) \quad (\text{V.3.2})$$

$$\int_0^w \frac{\sin(x-a)}{\sqrt{x}} dx = -ra(w) \cos[w - rt(w) - a] + \sqrt{\pi} \cos\left(a + \frac{\pi}{4}\right) \quad (\text{V.3.3})$$

$$\int_0^w \sqrt{x} e^{-ix} dx = j \sqrt{w} e^{-iw} + \frac{1}{2} rc(w) e^{-iw} - (1+j) \sqrt{\frac{\pi}{8}} \quad (\text{V.3.4})$$

$$\int_0^w \frac{e^{-ix}}{x^{\frac{3}{2}}} dx = 2 \frac{e^{-iw}}{\sqrt{w}} - 2ra(w) e^{-i[w - rt(w)]} \quad (\text{V.3.5})$$

$$\int_0^w \frac{rc(x)}{\sqrt{x}} dx = ic(w) \quad (\text{V.3.6})$$

$$\int_0^w \frac{rr(x)}{\sqrt{x}} dx = ir(w) \quad (\text{V.3.7})$$

$$\int_0^w \frac{rj(x)}{\sqrt{x}} dx = ij(w) = \frac{\pi}{2} - \frac{1}{2} ra^2(w) \quad (\text{V.3.8})$$

$$\int_0^w \frac{ic(x)}{\sqrt{x}} dx = 2 \sqrt{w} ic(w) - 4 \sqrt{w} + 2j rc(w) + (1-j) \sqrt{2\pi} \quad (\text{V.3.9})$$

$$\int_0^w \frac{ir(x)}{\sqrt{x}} dx = 2 \sqrt{w} ir(w) - 4 \sqrt{w} - 2rj(w) + \sqrt{2\pi} \quad (\text{V.3.10})$$

$$\int_0^w \frac{ij(x)}{\sqrt{x}} dx = 2 \sqrt{w} ij(w) + 2rr(w) - \sqrt{2\pi} \quad (\text{V.3.11})$$

$$\int_0^w \frac{ra^2(x)}{\sqrt{x}} dx = 2 \sqrt{w} ra^2(w) - 4rr(w) + \sqrt{8\pi} \quad (\text{V.3.12})$$

$$\int_0^w rc(x) dx = 2 \sqrt{w} - j rc(w) - (1-j) \sqrt{\frac{\pi}{2}} \quad (\text{V.3.13})$$

$$\int_0^w rr(x) dx = 2 \sqrt{w} + rj(w) - \sqrt{\frac{\pi}{2}} \quad (\text{V.3.14})$$

$$\int_0^w rj(x) dx = -rr(w) + \sqrt{\frac{\pi}{2}} \quad (\text{V.3.15})$$

$$\int_0^w ic(x) dx = w ic(w) - w + j \sqrt{w} rc(w) - \frac{1}{2} j ic(w) \quad (\text{V.3.16})$$

$$\int_0^w ir(x) dx = w ir(w) - w - \sqrt{w} rj(w) - \frac{1}{4} ra^2(w) + \frac{\pi}{4} \quad (\text{V.3.17})$$

$$\int_0^w ij(x) dx = \frac{1}{2} \pi w - \frac{1}{2} w ra^2(w) + \sqrt{w} rr(w) - \frac{1}{2} ir(w) \quad (\text{V.3.18})$$

$$\int_0^w ra^2(x) dx = w ra^2(w) - 2 \sqrt{w} rr(w) + ir(w) \quad (\text{V.3.19})$$

$$\int_0^w rc(x) e^{-ix} dx = w ra(w) e^{-j[w-rt(w)]} - \sqrt{w} e^{-iw} \\ + \frac{1}{2} j ra(w) e^{-j[w-rt(w)]} + \sqrt{\frac{\pi}{8}} (1 - j) \quad (\text{V.3.20})$$

$$\int_0^w rc(x) e^{ix} dx = -\frac{1}{2} j ra(w) e^{j[w+rt(w)]} - \frac{1}{2} j ra(w) e^{j[w-rt(w)]} + j \sqrt{\frac{\pi}{2}} \\ = -j rr(w) e^{iw} + j \sqrt{\frac{\pi}{2}} \quad (\text{V.3.21})$$

$$\int_0^w \cos x rr(x) dx = \frac{1}{2} w ra(w) \cos [w - rt(w)] - \frac{1}{2} \sqrt{w} \cos w \\ + \sin w rr(w) - \frac{1}{4} ra(w) \sin [w + rt(w)] + \frac{1}{4} \sqrt{\frac{\pi}{2}} \quad (\text{V.3.22})$$

$$\int_0^w \sin x rr(x) dx = \frac{1}{2} w ra(w) \sin [w - rt(w)] - \frac{1}{2} \sqrt{w} \sin w \\ - \cos w rr(w) + \frac{1}{4} ra(w) \cos [w + rt(w)] + \frac{3}{4} \sqrt{\frac{\pi}{2}} \quad (\text{V.3.23})$$

$$\int_0^w \cos x rj(x) dx = -\frac{1}{2} w ra(w) \sin [w - rt(w)] + \frac{1}{2} \sqrt{w} \sin w \\ - \frac{1}{4} ra(w) \cos [w + rt(w)] + \frac{1}{4} \sqrt{\frac{\pi}{2}} \quad (\text{V.3.24})$$

$$\int_0^w \sin x rj(x) dx = \frac{1}{2} w ra(w) \cos [w - rt(w)] - \frac{1}{2} \sqrt{w} \cos w \\ - \frac{1}{4} ra(w) \sin [w + rt(w)] + \frac{1}{4} \sqrt{\frac{\pi}{2}} \quad (\text{V.3.25})$$

$$\int_0^w rc(x) e^{ikx} dx = \frac{1}{\sqrt{k} (1+k)} \left[\sqrt{\frac{\pi}{2}} (1+j) - j ra(kw) e^{j[kw-rt(kw)]} \right] \\ - \frac{1}{1+k} \left[\sqrt{\frac{\pi}{2}} (1-j) + j ra(w) e^{j[kw+rt(w)]} \right] \quad (\text{V.3.26})$$

$$\int_0^w rc(x) e^{-ikx} dx = \frac{1}{\sqrt{k} (1-k)} \left[\sqrt{\frac{\pi}{2}} (1-j) + j ra(kw) e^{-j[kw-rt(kw)]} \right] \\ - \frac{1}{1-k} \left[\sqrt{\frac{\pi}{2}} (1-j) + j ra(w) e^{-j[kw-rt(w)]} \right] \quad (\text{V.3.27})$$

$$\int_0^w \cos kx rr(x) dx = \frac{k}{k^2 - 1} \sin kw rr(w) + \frac{1}{k^2 - 1} \left[\sqrt{\frac{\pi}{2}} - \cos kw rj(w) \right] - \frac{1}{\sqrt{k}(k^2 - 1)} \left\{ \sqrt{\frac{\pi}{2}} + ra(kw) \sin [kw - rt(kw)] \right\} \quad (V.3.28)$$

$$\int_0^w \sin kx rr(x) dx = \frac{k}{k^2 - 1} \left[\sqrt{\frac{\pi}{2}} - \cos kw rr(w) \right] - \frac{1}{k^2 - 1} \sin kw rj(w) - \frac{1}{\sqrt{k}(k^2 - 1)} \left\{ \sqrt{\frac{\pi}{2}} - ra(kw) \cos [kw - rt(kw)] \right\} \quad (V.3.29)$$

$$\int_0^w \cos kx rj(x) dx = \frac{k}{k^2 - 1} \sin kw rj(w) + \frac{\sqrt{k}}{k^2 - 1} \left\{ \sqrt{\frac{\pi}{2}} - ra(kw) \cos [kw - rt(kw)] \right\} - \frac{1}{k^2 - 1} \left[\sqrt{\frac{\pi}{2}} - \cos kw rr(w) \right] \quad (V.3.30)$$

$$\int_0^w \sin kx rj(x) dx = \frac{k}{k^2 - 1} \left[\sqrt{\frac{\pi}{2}} - \cos kw rj(w) \right] - \frac{\sqrt{k}}{k^2 - 1} \left\{ \sqrt{\frac{\pi}{2}} + ra(kw) \sin [kw - rt(kw)] \right\} + \frac{1}{k^2 - 1} \sin kw rr(w) \quad (V.3.31)$$

$$\int_0^w \frac{rc(x)e^{-ix}}{\sqrt{x}} dx = 2 \sqrt{w} rc(w)e^{-iw} - 2e^{-iw} + 2 \quad (V.3.32)$$

$$\int_0^w rc^2(x)e^{-ix} dx = 4 \sqrt{w} rc(w)e^{-iw} - j rc^2(w)e^{-iw} - 4e^{-iw} - \pi + 4 \quad (V.3.33)$$

$$\int_0^w x rc(x)e^{ix} dx = \frac{e^{iw}}{4} [3rr(w) - j rj(w) - 2j \sqrt{w} - 2jw rc(w)] - \left(\frac{3}{4} - \frac{1}{4}j \right) \sqrt{\frac{\pi}{2}} \quad (V.3.34)$$

$$\int_0^w x rc(x)e^{-ix} dx = \frac{e^{-iw}}{8} [-4w^{\frac{3}{2}} + 4w^2 rc(w) + 6j \sqrt{w} + 3rc(w)] - \frac{3}{8} (1 + j) \sqrt{\frac{\pi}{2}} \quad (V.3.35)$$

4. Integrals Obtained by Special Methods

Multiplication and division of the second member of (V.1.2) by e^{ia} gives

$$rc(w) = j e^{j(w-a)} \int_w^\infty \frac{e^{-j(x-a)}}{\sqrt{x}} dx \quad (V.4.1)$$

Multiplying both members of (V.3.20) by e^{ia} yields

$$\int_0^w ra(x)e^{-i[x-rt(x)-a]} dx = w ra(w)e^{-i[w-rt(w)-a]} \\ - \sqrt{w} e^{-i(w-a)} + \frac{1}{2} j ra(w)e^{-i[w-rt(w)-a]} + \sqrt{\frac{\pi}{8}} (1-j)e^{ia}$$

by (V.1.13). We get

$$\int_0^w ra(x) \cos [x - rt(x) - a] dx = w ra(w) \cos [w - rt(w) - a] \\ - \sqrt{w} \cos (w - a) + \frac{1}{2} ra(w) \sin [w - rt(w) - a] \\ + \sqrt{\frac{\pi}{8}} (\cos a + \sin a) \quad (\text{V.4.2})$$

$$\int_0^w ra(x) \sin [x - rt(x) - a] dx = w ra(w) \sin [w - rt(w) - a] \\ - \sqrt{w} \sin (w - a) - \frac{1}{2} ra(w) \cos [w - rt(w) - a] \\ + \sqrt{\frac{\pi}{8}} (\cos a - \sin a) \quad (\text{V.4.3})$$

Substitution of $x = y + w$ in (V.1.2) results in

$$rc(w) = j \int_0^\infty \frac{e^{-iy}}{\sqrt{y+w}} dy \quad (\text{V.4.4})$$

In this, put $y = wx$, with the result for $w > 0$,

$$rc(w) = j \sqrt{w} \int_0^\infty \frac{e^{-jwx}}{\sqrt{x+1}} dx \quad (\text{V.4.5})$$

The substitution $y = -jx$ in (V.4.4) yields

$$rc(w) = \int_0^\infty \frac{e^{-x}}{\sqrt{w-jx}} dx \quad (\text{V.4.6})$$

since the contribution to the integral in the complex plane along the rest of the contour vanishes in the limit. The substitution $x = wy$ in this gives, for $w > 0$,

$$rc(w) = \sqrt{w} \int_0^\infty \frac{e^{-wy}}{\sqrt{1-jy}} dy \quad (\text{V.4.7})$$

From a table of definite integrals, we easily deduce

$$\frac{\sqrt{\pi}}{2\sqrt{x}} = \int_0^\infty e^{-xy^2} dy$$

Multiply both members by $2e^{-iz}/\sqrt{\pi}$ and integrate with respect to x from w to ∞

$$\int_w^\infty \frac{e^{-iz}}{\sqrt{x}} dx = \frac{2}{\sqrt{\pi}} \int_w^\infty e^{-iz} \int_0^\infty e^{-zy^2} dy dx$$

Change the order of integration

$$\begin{aligned} \int_w^\infty \frac{e^{-iz}}{\sqrt{x}} dx &= \frac{2}{\sqrt{\pi}} \int_0^\infty \int_w^\infty e^{-(y^2+i)z} dx dy \\ &= \frac{2}{\sqrt{\pi}} \int_0^\infty \frac{e^{-(y^2+i)w}}{y^2 + j} dy \end{aligned}$$

and, multiplying both sides by je^{iw} , obtain, by (V.1.2),

$$rc(w) = \frac{2}{\sqrt{\pi}} \int_0^\infty \frac{e^{-wy^2}}{1 - jy^2} dy \tag{V.4.8}$$

Substituting $y = x/\sqrt{w}$ yields, for $w > 0$,

$$rc(w) = 2\sqrt{\frac{w}{\pi}} \int_0^\infty \frac{e^{-x^2}}{w - jx^2} dx \tag{V.4.9}$$

If we let $x = \sqrt{j}y$ in (V.4.9), we find, for $w > 0$,

$$rc(w) = (1 + j) \sqrt{\frac{2w}{\pi}} \int_0^\infty \frac{e^{-iy^2}}{w + y^2} dy \tag{V.4.10}$$

by integration around a contour in the complex plane. We get

$$\int_0^\infty \frac{e^{-ix^2}}{x^2 + w} dx = \sqrt{\frac{\pi}{8w}} (1 - j)rc(w)$$

$$\int_0^\infty \frac{\cos x^2}{x^2 + w} dx = \sqrt{\frac{\pi}{8w}} [rr(w) + rj(w)] \tag{V.4.11}$$

$$\int_0^\infty \frac{\sin x^2}{x^2 + w} dx = \sqrt{\frac{\pi}{8w}} [rr(w) - rj(w)] \tag{V.4.12}$$

Taking $rc(x)$ as given by (V.4.8), multiplying both members by e^{-ikz} , integrating from w to ∞ , and changing the order of integration, we get

$$\int_w^\infty e^{-ikz}rc(x) dx = \frac{2}{\sqrt{\pi}} \int_0^\infty \frac{e^{-(y^2+jk)w}}{(y^2 + jk)(1 - jy^2)} dy$$

Evaluating the first member by (V.3.27) and dividing both members by je^{-ikw} , we obtain

$$\frac{1}{1 - k} \left[rc(w) - \frac{rc(kw)}{\sqrt{k}} \right] = \frac{2}{\sqrt{\pi}} \int_0^\infty \frac{e^{-wy^2}}{(y^2 + jk)(y^2 + j)} dy$$

If we let $y = x/\sqrt{w}$, the second member becomes

$$2w \sqrt{\frac{w}{\pi}} \int_0^{\infty} \frac{e^{-x^2}}{(x^2 + jwk)(x^2 + jw)} dx$$

and by $x = \sqrt{j} y$

$$-(1 + j) \sqrt{\frac{2w^3}{\pi}} \int_0^{\infty} \frac{e^{-iy^2}}{(y^2 + wk)(y^2 + w)} dy$$

Letting $v = wk$, we obtain

$$\int_0^{\infty} \frac{e^{-ix^2}}{(x^2 + v)(x^2 + w)} dx = \sqrt{\frac{\pi}{8}} \frac{1 - j}{v - w} \left[\frac{rc(w)}{\sqrt{w}} - \frac{rc(v)}{\sqrt{v}} \right] \quad (\text{V.4.13})$$

$$\int_0^{\infty} \frac{\cos x^2}{(x^2 + v)(x^2 + w)} dx = \sqrt{\frac{\pi}{8}} \frac{1}{v - w} \left[\frac{rr(w)}{\sqrt{w}} + \frac{rj(w)}{\sqrt{w}} - \frac{rr(v)}{\sqrt{v}} - \frac{rj(v)}{\sqrt{v}} \right] \quad (\text{V.4.14})$$

$$\int_0^{\infty} \frac{\sin x^2}{(x^2 + v)(x^2 + w)} dx = \sqrt{\frac{\pi}{8}} \frac{1}{v - w} \left[\frac{rr(w)}{\sqrt{w}} - \frac{rj(w)}{\sqrt{w}} - \frac{rr(v)}{\sqrt{v}} + \frac{rj(v)}{\sqrt{v}} \right] \quad (\text{V.4.15})$$

Differentiation with respect to w would result in further integral formulas.

We verify the equation

$$[e^{-iw}rc(w)]^2 = 2j \int_0^{\infty} \frac{e^{-(x+2j)w}}{(x + 2j) \sqrt{1 - jx}} dx \quad (\text{V.4.16})$$

by noting that the derivatives with respect to w of the two members are equal for $w > 0$ by (V.4.7) and that both members approach zero as w goes to infinity. Multiplying both members by e^{2iw} gives

$$rc^2(w) = 2j \int_0^{\infty} \frac{e^{-wx}}{(x + 2j) \sqrt{1 - jx}} dx$$

and substituting $x = jy$ results in

$$rc^2(w) = 2j \int_0^{\infty} \frac{e^{-iwy}}{(y + 2) \sqrt{y + 1}} dy \quad (\text{V.4.17})$$

Making use of the substitution $w(y + 1) = x^2$, we get, for $w > 0$,

$$rc^2(w) = 4j \sqrt{w} e^{iw} \int_{\sqrt{w}}^{\infty} \frac{e^{-x^2}}{x^2 + w} dx$$

Putting $w = v^2$, we find

$$\int_v^\infty \frac{e^{-ix^2}}{x^2 + v^2} dx = -j \frac{e^{-iv^2}}{4v} rc^2(v^2) \tag{V.4.18}$$

$$\int_v^\infty \frac{\cos x^2}{x^2 + v^2} dx = \frac{1}{4v} [rj^2(v^2) \sin v^2 - rr^2(v^2) \sin v^2 + 2rr(v^2)rj(v^2) \cos v^2] \tag{V.4.19}$$

$$\int_v^\infty \frac{\sin x^2}{x^2 + v^2} dx = \frac{1}{4v} [rr^2(v^2) \cos v^2 - rj^2(v^2) \cos v^2 + 2rr(v^2)rj(v^2) \sin v^2] \tag{V.4.20}$$

Integrals from 0 to v can be obtained from (V.4.11), (V.4.12), (V.4.19), and (V.4.20) by subtraction. By differentiation with respect to v we could get expressions for the integrals

$$\begin{aligned} & \int_0^\infty \frac{\cos x^2}{(x^2 + v^2)^2} dx \\ & \int_0^\infty \frac{\sin x^2}{(x^2 + v^2)^2} dx \\ & \int_v^\infty \frac{\cos x^2}{(x^2 + v^2)^2} dx \\ & \int_v^\infty \frac{\sin x^2}{(x^2 + v^2)^2} dx \end{aligned}$$

Further differentiation would yield further relations.

If we write

$$\overline{rc}(w) = rr(w) - jrj(w)$$

[see (III.1.27)], then, by taking the conjugate complex of both sides of (V.4.7), we get for $\gamma > 1$

$$\begin{aligned} \overline{rc}(w) &= \sqrt{w} \int_0^\infty \frac{e^{-wy}}{\sqrt{1 + jy}} dy \\ \int_0^\infty \frac{\overline{rc}[(\gamma - 1)x]e^{i\gamma x}}{\sqrt{(\gamma - 1)x}} dx &= \int_0^\infty e^{i\gamma x} \int_0^\infty \frac{e^{-(\gamma - 1)xy}}{\sqrt{1 + jy}} dy dx \end{aligned}$$

Changing the order of integration gives

$$\begin{aligned} \int_0^\infty \frac{\overline{rc}[(\gamma - 1)x]e^{i\gamma x}}{\sqrt{(\gamma - 1)x}} dx &= \int_0^\infty \frac{1}{\sqrt{1 + jy}} \int_0^\infty e^{i\gamma x - (\gamma - 1)xy} dx dy \\ &= \int_0^\infty \frac{1}{\sqrt{1 + jy} [(\gamma - 1)y - j\gamma]} dy \end{aligned}$$

The second member becomes

$$\int_0^{\infty} \frac{1}{\sqrt{1+x}[(\gamma-1)x+\gamma]} dx$$

by the substitution $y = -jx$ and then

$$\int_1^{\infty} \frac{2}{(\gamma-1)y^2+1} dy$$

by letting $x = y^2 - 1$. By an elementary integral formula we then get

$$\int_0^{\infty} \frac{\overline{rc}[(\gamma-1)x]e^{j\gamma x}}{\sqrt{(\gamma-1)x}} dx = \frac{2}{\sqrt{\gamma-1}} \left(\frac{\pi}{2} - \tan^{-1} \sqrt{\gamma-1} \right) \quad (\text{V.4.21})$$

Proceeding as in the preceding paragraph, we arrive at

$$\int_0^{\infty} \frac{\overline{rc}[(\gamma+1)x]e^{j\gamma x}}{\sqrt{(\gamma+1)x}} dx = \int_0^{\infty} \frac{1}{\sqrt{1+x}[(\gamma+1)x+\gamma]} dx$$

Substituting $x = y^2 - 1$, we find

$$\int_1^{\infty} \frac{2}{(\gamma+1)y^2-1} dy = \frac{1}{\sqrt{\gamma+1}} \left[\ln \frac{\sqrt{\gamma+1} - (1/y)}{\sqrt{\gamma+1} + (1/y)} \right]_1^{\infty}$$

for the second member. There results

$$\int_0^{\infty} \frac{\overline{rc}[(\gamma+1)x]e^{j\gamma x}}{\sqrt{(\gamma+1)x}} dx = \frac{1}{\sqrt{\gamma+1}} \ln \frac{\sqrt{\gamma+1}+1}{\sqrt{\gamma+1}-1} \quad (\text{V.4.22})$$

5. Relations with Other Functions

We get

$$rc(w) = \sqrt{\frac{\pi}{2}} (1+j)e^{jw} - \sqrt{2\pi} j e^{jw} \left[C\left(\sqrt{\frac{2w}{\pi}}\right) - jS\left(\sqrt{\frac{2w}{\pi}}\right) \right] \quad (\text{V.5.1})$$

from (V.3.1) and the usual definition of the Fresnel integrals

$$C(u) = \int_0^u \cos \frac{\pi y^2}{2} dy \quad (\text{V.5.2})$$

$$S(u) = \int_0^u \sin \frac{\pi y^2}{2} dy \quad (\text{V.5.3})$$

If we let

$$w = \frac{\pi u^2}{2} \quad (\text{V.5.4})$$

$$v = w - rt(w) \quad (\text{V.5.5})$$

we find:

$$C(u) = \frac{1}{2} + \frac{1}{\sqrt{2\pi}} ra(w) \sin v \quad (\text{V.5.6})$$

$$S(u) = \frac{1}{2} - \frac{1}{\sqrt{2\pi}} ra(w) \cos v \quad (\text{V.5.7})$$

$$\int_0^u C(y) \sin \frac{\pi y^2}{2} dy = \frac{1}{8} + \frac{1}{4\pi} ir(w) - \frac{1}{\sqrt{8\pi}} ra(w) \cos v - \frac{1}{8\pi} ra^2(w) \sin 2v \quad (\text{V.5.8})$$

$$\int_0^u S(y) \cos \frac{\pi y^2}{2} dy = \frac{1}{8} - \frac{1}{4\pi} ir(w) + \frac{1}{\sqrt{8\pi}} ra(w) \sin v - \frac{1}{8\pi} ra^2(w) \sin 2v \quad (\text{V.5.9})$$

The four functions above are connected by the relation

$$\int_0^u C(y) \sin \frac{\pi y^2}{2} dy + \int_0^u S(y) \cos \frac{\pi y^2}{2} dy = C(u)S(u) \quad (\text{V.5.10})$$

Two other functions are sometimes called "Fresnel integrals," namely,

$$C(w) = \frac{1}{\sqrt{2\pi}} \int_0^w \frac{\cos x}{\sqrt{x}} dx \quad (\text{V.5.11})$$

$$S(w) = \frac{1}{\sqrt{2\pi}} \int_0^w \frac{\sin x}{\sqrt{x}} dx \quad (\text{V.5.12})$$

If we let

$$v = w - \pi t(w) \quad (\text{V.5.13})$$

we get

$$C(w) = \frac{1}{2} + \frac{1}{\sqrt{2\pi}} ra(w) \sin v \quad (\text{V.5.14})$$

$$S(w) = \frac{1}{2} - \frac{1}{\sqrt{2\pi}} ra(w) \cos v \quad (\text{V.5.15})$$

$$\frac{1}{\sqrt{2\pi}} \int_0^w \frac{C(x) \sin x}{\sqrt{x}} dx = \frac{1}{8} + \frac{1}{4\pi} ir(w) - \frac{1}{\sqrt{8\pi}} ra(w) \cos v - \frac{1}{8\pi} ra^2(w) \sin 2v \quad (\text{V.5.16})$$

$$\frac{1}{\sqrt{2\pi}} \int_0^w \frac{S(x) \cos x}{\sqrt{x}} dx = \frac{1}{8} - \frac{1}{4\pi} ir(w) + \frac{1}{\sqrt{8\pi}} ra(w) \sin v - \frac{1}{8\pi} ra^2(w) \sin 2v \quad (\text{V.5.17})$$

These four functions are related by the equation

$$\frac{1}{\sqrt{2\pi}} \int_0^w \frac{C(x) \sin x}{\sqrt{x}} dx + \frac{1}{\sqrt{2\pi}} \int_0^w \frac{S(x) \cos x}{\sqrt{x}} dx = C(w)S(w) \quad (V.5.18)$$

6. Power Series for the Functions

From (V.1.2) we obtain, with the help of (V.1.17),

$$rc(w) - \sqrt{\frac{\pi}{2}} (1 + j)e^{jw} = -je^{jw} \int_0^w \frac{e^{-ix}}{\sqrt{x}} dx \quad (V.6.1)$$

Expanding e^{-ix} as $\sum_{n=0}^{\infty} (-jx)^n/n!$ we get

$$\begin{aligned} rc(w) - \sqrt{\frac{\pi}{2}} (1 + j)e^{jw} &= 2e^{jw} \sum_{n=0}^{\infty} \frac{(-j)^{n+1}w^{n+1/2}}{n!(2n + 1)} \\ &= 2e^{jw} \left(-jw^{3/2} - \frac{w^5}{3} + j \frac{w^7}{2!5} + \frac{w^9}{3!7} - \dots \right) \end{aligned} \quad (V.6.2)$$

from which one can derive series for $rr(w)$ and $rj(w)$.

The second member of (V.6.2) is the product of a power series in w by a power series in \sqrt{w} . Represent this product by the expression

$$A_1 \sqrt{w} + A_3 w^{3/2} + A_5 w^{5/2} + \dots$$

in which the A 's are to be determined. Differentiation of both sides gives

$$\begin{aligned} jrc(w) - \frac{j}{\sqrt{w}} - j \sqrt{\frac{\pi}{2}} (1 + j)e^{jw} &= \frac{1}{2} A_1 \frac{1}{\sqrt{w}} \\ &\quad + \frac{3}{2} A_3 \sqrt{w} + \frac{5}{2} A_5 w^{3/2} + \dots \end{aligned}$$

or

$$\begin{aligned} -\frac{j}{\sqrt{w}} + j(A_1 \sqrt{w} + A_3 w^{3/2} + A_5 w^{5/2} + \dots) &= \frac{1}{2} A_1 \frac{1}{\sqrt{w}} \\ &\quad + \frac{3}{2} A_3 \sqrt{w} + \frac{5}{2} A_5 w^{3/2} + \dots \end{aligned}$$

Equating coefficients of like powers of \sqrt{w} gives

$$\begin{aligned} A_1 &= -2j \\ A_3 &= -\frac{(2j)^3}{1 \cdot 3} \\ A_5 &= -\frac{(2j)^5}{1 \cdot 3 \cdot 5} \\ &\dots \end{aligned}$$

so that

$$\begin{aligned}
 rc(w) - \sqrt{\frac{\pi}{2}}(1+j)e^{iw} &= - \sum_{n=1}^{\infty} (4j)^n \frac{n!}{(2n)!} w^{n-\frac{1}{2}} \\
 &= -j2\sqrt{w} + \frac{2^2}{1 \cdot 3} w^{\frac{3}{2}} + j \frac{2^3}{1 \cdot 3 \cdot 5} w^{\frac{5}{2}} \\
 &\quad - \frac{2^4}{1 \cdot 3 \cdot 5 \cdot 7} w^{\frac{7}{2}} - \dots \quad (V.6.3)
 \end{aligned}$$

$$\begin{aligned}
 rr(w) - \sqrt{\frac{\pi}{2}} \cos w + \sqrt{\frac{\pi}{2}} \sin w &= - \sum_{n=1}^{\infty} (-16)^n \frac{(2n)!}{(4n)!} w^{2n-\frac{1}{2}} \\
 &= \frac{2^2}{1 \cdot 3} w^{1.5} - \frac{2^4}{1 \cdot 3 \cdot 5 \cdot 7} w^{3.5} \\
 &\quad + \frac{2^6}{1 \cdot 3 \cdot 5 \cdot 7 \cdot 9 \cdot 11} w^{5.5} - \dots \quad (V.6.4)
 \end{aligned}$$

$$\begin{aligned}
 rj(w) - \sqrt{\frac{\pi}{2}} \cos w - \sqrt{\frac{\pi}{2}} \sin w &= - \sum_{n=0}^{\infty} (-16)^n \frac{2(2n)!}{(4n+1)!} w^{2n+\frac{1}{2}} \\
 &= -2w^{0.5} + \frac{2^3}{1 \cdot 3 \cdot 5} w^{2.5} - \frac{2^5}{1 \cdot 3 \cdot 5 \cdot 7 \cdot 9} w^{4.5} + \dots \quad (V.6.5)
 \end{aligned}$$

From (V.1.6) and (V.6.3) we obtain

$$ic(w) = \sqrt{\frac{\pi}{2}}(1+j) \int_0^w \frac{e^{ix}}{\sqrt{x}} dx - \int_0^w \sum_{n=1}^{\infty} (4j)^n \frac{n!}{(2n)!} x^{n-1} dx$$

Replacing j by $-j$ in (V.3.1), yields

$$\int_0^w \frac{e^{ix}}{\sqrt{x}} dx = -j \overline{rc}(w) e^{iw} + (1+j) \sqrt{\frac{\pi}{2}}$$

We find

$$ic(w) = \sqrt{\frac{\pi}{2}}(1-j) \overline{rc}(w) e^{iw} + j\pi - \sum_{n=1}^{\infty} (4j)^n \frac{(n-1)!}{(2n)!} w^n \quad (V.6.6)$$

$$\begin{aligned}
 ir(w) = \sqrt{\frac{\pi}{2}} [rr(w) \cos w + rr(w) \sin w - rj(w) \cos w \\
 + rj(w) \sin w] + \frac{(2w)^2}{1 \cdot 3 \cdot 2} - \frac{(2w)^4}{1 \cdot 3 \cdot 5 \cdot 7 \cdot 4} \\
 + \frac{(2w)^6}{1 \cdot 3 \cdot 5 \cdot 7 \cdot 9 \cdot 11 \cdot 6} - \dots \quad (V.6.7)
 \end{aligned}$$

$$\begin{aligned}
 ra^2(w) = \sqrt{2\pi} [rr(w) \cos w - rr(w) \sin w + rj(w) \cos w \\
 + rj(w) \sin w] - \pi + 2(2w) - \frac{2(2w)^3}{1 \cdot 3 \cdot 5 \cdot 3} \\
 + \frac{2(2w)^5}{1 \cdot 3 \cdot 5 \cdot 7 \cdot 9 \cdot 5} - \dots \quad (V.6.8)
 \end{aligned}$$

All six tabulated functions are analytic functions of \sqrt{w} in the neighborhood of the origin. Hence, for w near zero, one can compute any of the functions from the first few terms of the power series in \sqrt{w} . We give the first few terms of the series in question, using the abbreviation

$$q = \sqrt{\frac{\pi}{2}} \tag{V.6.9}$$

$$rr(w) = q - qw + \frac{1}{3}w^{\frac{3}{2}} - \frac{1}{15}qw^2 + \frac{1}{63}qw^3 - \frac{1}{105}w^{\frac{5}{2}} + \dots \tag{V.6.10}$$

$$rj(w) = q - 2w^{\frac{3}{2}} + qw - \frac{1}{15}qw^2 + \frac{1}{15}w^{\frac{5}{2}} - \frac{1}{63}qw^3 + \dots \tag{V.6.11}$$

$$ra^2(w) = \pi - 4qw^{\frac{3}{2}} + 4w - \frac{4}{15}qw^2 + \frac{4}{3}qw^3 - \frac{1}{15}w^{\frac{5}{2}} + \frac{2}{15}qw^{\frac{7}{2}} + \dots \tag{V.6.12}$$

$$ir(w) = 2qw^{\frac{3}{2}} - \frac{4}{15}qw^2 + \frac{4}{3}w^2 - \frac{1}{15}qw^3 + \frac{1}{15}qw^{\frac{5}{2}} + \dots \tag{V.6.13}$$

$$ra(w) = \sqrt{\pi} - \sqrt{2} w^{\frac{3}{2}} + \frac{1}{\sqrt{\pi}} w - \sqrt{2} \left(\frac{1}{3} - \frac{1}{\pi} \right) w^{\frac{3}{2}} - \frac{1}{\sqrt{\pi}} \left(\frac{2}{3} - \frac{3}{2\pi} \right) w^2 + \dots \tag{V.6.14}$$

$$rt(w) = \frac{\pi}{4} - \frac{1}{q} w^{\frac{3}{2}} + \left(1 - \frac{2}{\pi} \right) w - \frac{1}{3q} \left(\frac{4}{\pi} - 1 \right) w^{\frac{3}{2}} + \dots \tag{V.6.15}$$

7. Asymptotic Expansions for the Functions

The functions $rr(w)$ and $rj(w)$ will receive attention first. From (V.4.8) we get

$$rr(w) = \frac{2}{\sqrt{\pi}} \int_0^\infty \frac{e^{-wy^2}}{1+y^4} dy \tag{V.7.1}$$

$$rj(w) = \frac{2}{\sqrt{\pi}} \int_0^\infty \frac{y^2 e^{-wy^2}}{1+y^4} dy \tag{V.7.2}$$

It is obvious from these relations that $rr(w)$ and $rj(w)$ are positive monotonic functions, decreasing for increasing w .

From a table of definite integrals we read for $k \geq 0$

$$\begin{aligned} \int_0^\infty y^{2k} e^{-wy^2} dy &= \frac{(2k)!}{k! 2^{2k+1} w^k} \sqrt{\frac{\pi}{w}} \\ &= \frac{1 \cdot 3 \cdot 5 \cdots (2k-1)}{2^{k+1} w^k} \sqrt{\frac{\pi}{w}} \end{aligned} \tag{V.7.3}$$

One verifies by induction on n that

$$\frac{1}{1+y^4} = 1 - y^4 + y^8 - \dots + (-1)^n y^{4n} + (-1)^{n+1} \frac{y^{4n+4}}{1+y^4}$$

One substitutes this into (V.7.1) and (V.7.2) and gets

$$\begin{aligned}
 rr(w) &= \frac{1}{\sqrt{w}} \left[1 - \frac{1 \cdot 3}{(2w)^2} + \frac{1 \cdot 3 \cdot 5 \cdot 7}{(2w)^4} - \dots \right. \\
 &\quad \left. + (-1)^n \frac{1 \cdot 3 \cdot 5 \cdot \dots \cdot (4n - 1)}{(2w)^{2n}} \right] \\
 &\quad + (-1)^{n+1} \frac{2}{\sqrt{\pi}} \int_0^\infty \frac{y^{4n+4} e^{-wy^2}}{1 + y^4} dy \\
 rj(w) &= \frac{1}{\sqrt{w}} \left[\frac{1}{2w} - \frac{1 \cdot 3 \cdot 5}{(2w)^3} + \frac{1 \cdot 3 \cdot 5 \cdot 7 \cdot 9}{(2w)^5} - \dots \right. \\
 &\quad \left. + (-1)^n \frac{1 \cdot 3 \cdot 5 \cdot \dots \cdot (4n + 1)}{(2w)^{2n+1}} \right] \\
 &\quad + (-1)^{n+1} \frac{2}{\sqrt{\pi}} \int_0^\infty \frac{y^{4n+6} e^{-wy^2}}{1 + y^4} dy
 \end{aligned}$$

The term containing the integral is a remainder, and by replacing the $1 + y^4$ in the denominator by its minimum value, unity, we can show that the remainder is numerically less than the absolute value of the first term neglected. Clearly it has the same sign. Although these series diverge eventually, a finite number of terms may be used as an approximation, and the numerical value of the error made is not greater than that of the first term neglected. So we have the asymptotic expansions

$$\begin{aligned}
 rr(w) &\stackrel{a}{=} \frac{1}{\sqrt{w}} \sum_{k=0}^n (-1)^k \frac{(4k)!}{(2k)! 2^{4k} w^{2k}} \\
 &\stackrel{a}{=} \frac{1}{\sqrt{w}} \left[1 - \frac{1 \cdot 3}{(2w)^2} + \frac{1 \cdot 3 \cdot 5 \cdot 7}{(2w)^4} - \frac{1 \cdot 3 \cdot 5 \cdot 7 \cdot 9 \cdot 11}{(2w)^6} \right. \\
 &\quad \left. + \dots \right] \quad (V.7.4)
 \end{aligned}$$

$$\begin{aligned}
 rj(w) &\stackrel{a}{=} \frac{1}{\sqrt{w}} \sum_{k=0}^n (-1)^k \frac{(4k + 1)!}{(2k)! 2^{4k+1} w^{2k+1}} \\
 &\stackrel{a}{=} \frac{1}{\sqrt{w}} \left[\frac{1}{2w} - \frac{1 \cdot 3 \cdot 5}{(2w)^3} + \frac{1 \cdot 3 \cdot 5 \cdot 7 \cdot 9}{(2w)^5} \right. \\
 &\quad \left. - \frac{1 \cdot 3 \cdot 5 \cdot 7 \cdot 9 \cdot 11 \cdot 13}{(2w)^7} + \dots \right] \quad (V.7.5)
 \end{aligned}$$

Combining (V.7.4) and (V.7.5), we get

$$\begin{aligned}
 rc(w) &\doteq \frac{1}{\sqrt{w}} \sum_{k=0}^n j^k \frac{(2k)!}{k! 4^k w^k} \\
 &\doteq \frac{1}{\sqrt{w}} \left[1 + j \frac{1}{2w} - \frac{1 \cdot 3}{(2w)^2} - j \frac{1 \cdot 3 \cdot 5}{(2w)^3} \right. \\
 &\quad \left. + \frac{1 \cdot 3 \cdot 5 \cdot 7}{(2w)^4} + \dots \right] \quad (\text{V.7.6})
 \end{aligned}$$

It can be shown by (V.4.8) and (V.7.3) that the absolute value of the error made by taking n terms is less than the absolute value of the first term neglected.

We get from (V.1.6) and (V.4.6)

$$ic(w) = \int_0^w \frac{1}{\sqrt{x}} \int_0^\infty \frac{e^{-y}}{\sqrt{x - jy}} dy dx$$

and from a change in the order of integration

$$\begin{aligned}
 ic(w) &= \int_0^\infty e^{-y} \int_0^w \frac{1}{\sqrt{x} \sqrt{x - jy}} dx dy \\
 &= \int_0^\infty e^{-y} \left[2 \ln (\sqrt{jx} + \sqrt{jx + y}) \right]_0^w dy \\
 &= \int_0^\infty e^{-y} 2 \ln \left[\sqrt{\frac{jw}{y}} \left(1 + \sqrt{1 - j \frac{y}{w}} \right) \right] dy \\
 &= \int_0^\infty e^{-y} \ln \frac{jw}{y} dy + \int_0^\infty e^{-y} 2 \ln \left(1 + \sqrt{1 - j \frac{y}{w}} \right) dy
 \end{aligned}$$

For the first integral one has

$$\begin{aligned}
 \int_0^\infty e^{-y} \ln \frac{jw}{y} dy &= (\ln w + \ln j) \int_0^\infty e^{-y} dy - \int_0^\infty e^{-y} \ln y dy \\
 &= \ln w + j \frac{\pi}{2} + \gamma
 \end{aligned}$$

where γ is the Euler-Mascheroni constant (see page 507 of Reference 2). The other integral approaches

$$\int_0^\infty e^{-y} 2 \ln 2 dy = \ln 4$$

as w becomes infinite. So we find

$$\lim_{w \rightarrow \infty} [ic(w) - \ln w] = \ln 4 + \gamma + j \frac{\pi}{2} \quad (\text{V.7.7})$$

and

$$ic(w) - \ln w = \ln 4 + \gamma + j \frac{\pi}{2} - \lim_{w \rightarrow \infty} \int_w^w \left[\frac{rc(x)}{\sqrt{x}} - \frac{1}{x} \right] dx \quad (\text{V.7.8})$$

By (V.7.6)

$$\frac{1}{\sqrt{x}} \left[rc(x) - \frac{1}{\sqrt{x}} \right] \stackrel{a}{=} \sum_{k=1}^n j^k \frac{(2k)!}{k!4^k x^{k+1}}$$

with an error which is at most

$$\frac{(2n + 2)!}{(n + 1)!4^{n+1}x^{n+2}}$$

So

$$\lim_{w \rightarrow \infty} \int_w^w \frac{1}{\sqrt{x}} \left[rc(x) - \frac{1}{\sqrt{x}} \right] dx \stackrel{a}{=} \sum_{k=1}^n j^k \frac{(2k)!}{k!4^k k w^k}$$

with an error which is at most

$$\frac{(2n + 2)!}{(n + 1)!4^{n+1}(n + 1)w^{n+1}} \tag{V.7.9}$$

Combining this with (V.7.8), we get

$$ic(w) - \ln w \stackrel{a}{=} \ln 4 + \gamma + j \frac{\pi}{2} - \sum_{k=1}^n j^k \frac{(2k)!}{k!4^k k w^k} \tag{V.7.10}$$

with an error at most (V.7.9).

From (V.7.10) we obtain

$$ir(w) \stackrel{a}{=} \ln 4 + \gamma + \ln w + \frac{1 \cdot 3}{2(2w)^2} - \frac{1 \cdot 3 \cdot 5 \cdot 7}{4(2w)^4} + \frac{1 \cdot 3 \cdot 5 \cdot 7 \cdot 9 \cdot 11}{6(2w)^6} - \dots \tag{V.7.11}$$

$$ra^2(w) \stackrel{a}{=} 2 \left[\frac{1}{2w} - \frac{1 \cdot 3 \cdot 5}{3(2w)^3} + \frac{1 \cdot 3 \cdot 5 \cdot 7 \cdot 9}{5(2w)^5} - \dots \right] \tag{V.7.12}$$

The proof that the error made is less than the value of the first term neglected follows easily from the same property for the expansions (V.7.4) and (V.7.5) of $rr(w)$ and $rj(w)$.

8. Other Means of Computation

In Reference 13 are given other means of computation of $rc(w)$. We quote, without proof, some useful results.

Define $P_n(y)$ and $Q_n(y)$ by the inductive definitions

$$P_0(y) = 1 \tag{V.8.1}$$

$$P_{n+1}(y) = 2jyP_n(y) + \frac{d}{dy} P_n(y) \tag{V.8.2}$$

$$Q_0(y) = 0 \tag{V.8.3}$$

$$Q_{n+1}(y) = 2jP_n(y) + \frac{d}{dy} Q_n(y) \tag{V.8.4}$$

Although the polynomials can be obtained from the definition, we list a few of them for reference

$$\begin{aligned}
 P_4(y) &= (2y)^4 - 12j(2y)^2 - 12 \\
 P_8(y) &= (2y)^8 - 56j(2y)^6 - 840(2y)^4 + 3,360j(2y)^2 + 1,680 \\
 P_{12}(y) &= (2y)^{12} - 132j(2y)^{10} - 5,940(2y)^8 + 110,880j(2y)^6 \\
 &\quad + 831,600(2y)^4 - 1,995,840j(2y)^2 - 665,280 \\
 P_{16}(y) &= (2y)^{16} - 240j(2y)^{14} - 21,840(2y)^{12} + 960,960j(2y)^{10} \\
 &\quad + 21,621,600(2y)^8 - 242,161,920j(2y)^6 \\
 &\quad - 1,210,809,600(2y)^4 + 2,075,673,600j(2y)^2 + 518,918,400 \\
 &\quad \cdot \cdot \cdot \\
 Q_4(y) &= 2(2y)^3 - 20j(2y) \\
 Q_8(y) &= 2(2y)^7 - 108j(2y)^5 - 1,480(2y)^3 + 4,464j(2y) \\
 Q_{12}(y) &= 2(2y)^{11} - 260j(2y)^9 - 11,376(2y)^7 + 200,928j(2y)^5 \\
 &\quad + 1,333,920(2y)^3 - 2,283,840j(2y) \\
 Q_{16}(y) &= 2(2y)^{15} - 476j(2y)^{13} - 42,744(2y)^{11} + 1,840,080j(2y)^9 \\
 &\quad + 39,869,280(2y)^7 - 416,404,800j(2y)^5 \\
 &\quad - 1,801,457,280(2y)^3 + 2,123,493,120j(2y) \\
 &\quad \cdot \cdot \cdot
 \end{aligned}$$

For finding a single polynomial it is convenient to use the formula

$$P_n(y) = \sum_{m=0}^{[n/2]} \frac{j^{n-m} n! (2y)^{n-2m}}{m!(n-2m)!} \tag{V.8.5}$$

in which $[n/2]$ denotes the largest integer not greater than $n/2$. One can compute $Q_n(y)$ by multiplying the asymptotic expansion (V.7.6) for $rc(y^2)$ by $P_n(y)$ and retaining only those terms of the product which are powers of $(2y)$ with nonnegative exponents. For computing $rc(y^2)$ one has

$$rc(y^2) = \frac{Q_{2n}(y)}{P_{2n}(y)} + \epsilon(n, a, y) \tag{V.8.6}$$

in which

$$|\epsilon(n, a, y)| \leq \frac{n!(2a)!4^{n-a}}{a|y|^{2a+1}|P_{2n}(y)|} \tag{V.8.7}$$

for $0 \leq a \leq n$.

For $N > 0$,

$$rc(w) = jN \sum_{n=-\infty}^{\infty} \frac{e^{-\pi n^2 w / N^2}}{n^2 \pi + jN^2} + \sqrt{\frac{\pi}{2}} (1 + j) e^{jw} \left\{ 1 - \coth \left[N \sqrt{\frac{\pi}{2}} (1 + j) \right] \right\} + \epsilon(w, N) \quad (V.8.8)$$

in which

$$|\epsilon(w, N)| \leq 4 \sqrt{w} \sum_{n=1}^{\infty} e^{-n^2 N^2 \pi / w} \quad (V.8.9)$$

If N is a multiple of $\sqrt{2\pi}$, then

$$\coth \left[N \sqrt{\frac{\pi}{2}} (1 + j) \right]$$

is real and easy to compute by means of a good table of exponentials.

In Reference 13 analogous methods for computing $ir(w)$ and $ra^2(w)$ are given, but they are much more complex, and we do not quote them. Also in Reference 13 are given 12-decimal-place tables of $Rr(u)$, $Ri(u)$, $Rr^2(u) + Ri^2(u)$, and $\int_0^u Rr(x) dx$, from which one can compute values of $rr(w)$, $rj(w)$, $ra^2(w)$, and $ir(w)$ by use of the relations

$$rr(w) = \sqrt{2\pi} Rr \left(\sqrt{\frac{2w}{\pi}} \right) \quad (V.8.10)$$

$$rj(w) = \sqrt{2\pi} Ri \left(\sqrt{\frac{2w}{\pi}} \right) \quad (V.8.11)$$

$$ra^2(w) = 2\pi \left[Rr^2 \left(\sqrt{\frac{2w}{\pi}} \right) + Ri^2 \left(\sqrt{\frac{2w}{\pi}} \right) \right] \quad (V.8.12)$$

$$ir(w) = 2\pi \int_0^{\sqrt{2w/\pi}} Rr(x) dx \quad (V.8.13)$$

9. Accuracy of Interpolation in Table 1

Table 1 gives the six rocket functions $rr(w)$, $rj(w)$, $ra^2(w)$, $ir(w)$, $ra(w)$, and $rt(w)$ as functions of w . As the six tabulated functions are analytic functions of \sqrt{w} near the origin, it is necessary to use smaller increments of the argument for the argument near zero. The user of these tables should be alert for changes in the argument interval.

In preparing the tables, values of the functions were computed to 8 or 9 decimal places. These values were then rounded off to 6 decimals. Estimates were made of the maximum error that was

likely to occur in the original computation, and in those cases where this error might be great enough to introduce an uncertainty as to whether one should round up or down, especially accurate values were computed. As a result of these pains, we feel that no tabulated function value is in error by as much as 0.0000005.

For interpolation into Table 1 we have listed a set of central second differences, δ^2 , for use with Everett's central difference interpolation formula

$$f(w + ph) = pf(w + h) + (1 - p)f(w) - E_2(p)\delta^2f(w + h) - E_2(1 - p)\delta^2f(w) + \text{terms involving higher differences} \quad (\text{V.9.1})$$

In this formula, h is the difference between successive argument values, w and $w + h$ are two successive argument values, $w + ph$ is the value of the argument (between w and $w + h$) at which the value of the function is desired (so that $0 < p < 1$), $f(w)$ and $f(w + h)$ are the function values listed opposite w and $w + h$, $\delta^2f(w)$ and $\delta^2f(w + h)$ are the second differences listed opposite w and $w + h$, and $E_2(p)$ and $E_2(1 - p)$ are the values of Everett's second difference interpolation coefficient defined by

$$E_2(x) = \frac{x(1 - x^2)}{6} \quad (\text{V.9.2})$$

A 5-decimal table of $E_2(p)$ is given in Table 2. Note that δ^2 is positive except for $\delta^2ir(w)$.

Let us use (V.9.1) to compute $ra^2(0.0032)$. We put $w = 0.0030$, $w + h = 0.0035$, $h = 0.0005$, $p = 0.4$. Then $w + ph = 0.0032$, the desired argument value. We read from the tables

$$\begin{aligned} f(w) &= 2.878731 \\ f(w + h) &= 2.858659 \\ \delta^2f(w) &= 0.001881 \\ \delta^2f(w + h) &= 0.001496 \\ E_2(p) &= 0.05600 \\ E_2(1 - p) &= 0.06400 \end{aligned}$$

So by (V.9.1),

$$\begin{aligned} ra^2(0.0032) &= (0.4)(2.858659) + (0.6)(2.878731) \\ &\quad - (0.056)(0.001496) - (0.064)(0.001881) \end{aligned}$$

A machine computation, keeping all digits that arise from multiplication, gives $ra^2(0.0032) = 2.87049804$. Clearly the last two digits are not significant, and so we get

$$ra^2(0.0032) = 2.870498$$

The true value rounded off to 8 places is

$$ra^2(0.0032) = 2.87049782$$

Let us consider the possible errors arising from the use of (V.9.1). As we have listed no higher differences beyond the second, the user of Table 1 is more or less forced to neglect higher differences. Over some of Table 1, it is permissible to neglect higher differences. In those parts of Table 1 where one cannot neglect higher differences, we have either refrained from listing a second difference (for values of w near zero) or else have listed a second difference which has been adjusted to compensate somewhat for the neglect of higher differences. With the adjusted second differences used in Table 1, the maximum error due to neglect of higher differences is less than 9×10^{-7} , and it is much less than this except at a few places near the beginning of Table 1.

For Table 1, the adjusted second differences are rounded off to 6 decimal places. Use of these rounded-off values instead of exact values for interpolation can introduce a further error of at most 0.65×10^{-7} .

If one uses the rounded-off values of $E_2(p)$ given in Table 2, a further error of at most 0.5×10^{-7} can arise from the rounding off of $E_2(p)$.

Finally, since the function values are rounded off to 6 decimals, the term $pf(w + h) + (1 - p)f(w)$ which occurs in (V.9.1) may be in error by as much as 5×10^{-7} .

We have so far disclosed the following sources of error:

Neglect of higher differences.....	9	$\times 10^{-7}$
Rounding off of second differences	0.65	$\times 10^{-7}$
Rounding off of interpolation coefficients.....	0.5	$\times 10^{-7}$
Rounding off of function values.....	5	$\times 10^{-7}$
Total.....	15.15	$\times 10^{-7}$

A careful study has shown that these errors do not ever attain their maximum values simultaneously and that the maximum error due to the causes listed so far is actually less than 15×10^{-7} . This is the error in the many-decimal value of $f(w + ph)$ which would result from substituting various table entries into (V.9.1). If one now rounds this off to a 6-decimal value, one might introduce a further error of at most 5×10^{-7} .

We conclude that (V.9.1) can be used to compute a 6-decimal value of $f(w + ph)$ which is in error by less than 2 in the sixth place.

If one has a value of p for which one must use interpolation to extract values of $E_2(p)$ and $E_2(1 - p)$ from Table 2, it is quite per-

missible to use linear interpolation, and the resulting values of $E_2(p)$ and $E_2(1 - p)$ will be sufficiently accurate so that our preceding remarks on the accuracy obtainable by use of (V.9.1) are still valid.

In some cases one will get an argument value from experimental data, and so the argument value will not be known with any great precision. As a result, p will not be known very precisely. Let us inquire into the possible error arising from an inaccuracy in p . We can break this error into two parts, namely, the error due to the inaccuracy in p and the error due to interpolation. We let p denote the true (but unknown) value of p , so that $w + ph$ is the true argument value. Let p^* be some rational approximation to p , namely, the value of p such that $w + p^*h$ is the rational number obtained by experiment as an approximate value of the argument $w + ph$. Then our error breaks into two parts, namely, the discrepancy between $f(w + ph)$ and $f(w + p^*h)$, and the discrepancy between $f(w + p^*h)$ and the value that would be obtained by using p^* in (V.9.1). We have seen that the latter is at most 2×10^{-6} . By elementary calculus

$$f(w + ph) - f(w + p^*h) \cong (p - p^*)hf'(w + p^*h)$$

By (V.2.1) to (V.2.9), one can compute $f'(w + p^*h)$.

Thus the total error when using an inaccurate value p^* , instead of an accurate value p , is $(p - p^*)hf'(w + p^*h)$ plus the usual maximum interpolation error of 2×10^{-6} .

If one wishes to use linear interpolation, one merely neglects the terms

$$-E_2(p)\delta^2f(w + h) - E_2(1 - p)\delta^2f(w) \quad (\text{V.9.3})$$

that occur in (V.9.1). Hence the possible error arising from linear interpolation will be the maximum error of 2×10^{-6} resulting from the use of (V.9.1) plus the maximum absolute value of (V.9.3). If M is the larger of the absolute values of $\delta^2f(w + h)$ and $\delta^2f(w)$, then the absolute value of (V.9.3) is at most $[E_2(p) + E_2(1 - p)]M$. One finds by elementary calculus that the maximum value of $E_2(p) + E_2(1 - p)$ occurs at $p = \frac{1}{2}$ and equals $\frac{1}{2}$. Hence the maximum absolute value of (V.9.3) is at most $M/8$. As a matter of fact, for Table 1, M is invariably the absolute value of $\delta^2f(w)$ (assuming h positive).

Hence the maximum error if one uses linear interpolation is $2 \times 10^{-6} + |\delta^2f(w)/8|$.

The reader will find linear interpolation sufficiently accurate for most purposes. Thus linear interpolation would have given

$$ra^2(0.0032) = 2.870702$$

which is in error by slightly over 0.0002, or less than one-hundredth of 1 per cent.

We conclude with a list of values of special constants that have a prominent place in the formulas of this chapter.

$\pi = 3.141592654$	$\frac{1}{\pi} = 0.3183098862$
$4\pi = 12.56637061$	$\frac{1}{4\pi} = 0.0795774715$
$8\pi = 25.13274123$	$\frac{1}{8\pi} = 0.0397887358$
$\sqrt{\pi} = 1.772453851$	$\frac{1}{\sqrt{\pi}} = 0.5641895835$
$\sqrt{2\pi} = 2.506628275$	$\frac{1}{\sqrt{2\pi}} = 0.3989422804$
$\sqrt{8\pi} = 5.013256549$	$\frac{1}{\sqrt{8\pi}} = 0.1994711402$
$\sqrt{\frac{\pi}{2}} = 1.253314137$	$\sqrt{\frac{2}{\pi}} = 0.7978845608$
$\sqrt{\frac{\pi}{8}} = 0.626657069$	$\sqrt{\frac{8}{\pi}} = 1.5957691216$
$\sqrt{2} = 1.414213562$	$\frac{\pi}{4} = 0.7853981634$
$\ln 4 + \gamma = 1.963510026$	

TABLE 1.—ROCKET

In using this table watch carefully for changes of argument interval. Note that δ^2 is positive except for $\delta^2 ir(w)$. A plus sign after a number indicates that

w	$rr(w)$	δ^2	$rj(w)$	δ^2	$ra^2(w)$	δ^2
0.0000	1.253314	..	1.253314	...	3.141593	
0.0001	1.253190	1	1.233439	...	3.091858	
0.0002	1.253067	1	1.225281	...	3.071490	
0.0003	1.252945 +	1	1.219049	...	3.055952	
0.0004	1.252823	0	1.213815 +	610	3.042914	1,529
0.0005	1.252702	0	1.209219	440	3.031474	1,104
0.0006	1.252582	0	1.205076	337	3.021169	843
0.0007	1.252461	0	1.201276	268	3.011723	671
0.0008	1.252341	0	1.197748	220	3.002959	550
0.0009	1.252222	0	1.194442	184	2.994750 -	462
0.0010	1.252102	0	1.191321	158	2.987007	394
0.0010	1.252102	1	1.191321	623	2.987007	1,560
0.0012	1.251865 -	1	1.185535 +	476	2.972659	1,192
0.0014	1.251628	1	1.180234	379	2.959526	948
0.0016	1.251393	1	1.175318	311	2.947355 +	777
0.0018	1.251158	1	1.170715 +	261	2.935971	652
0.0020	1.250924	1	1.166376	223	2.925244	557
0.0022	1.250691	1	1.162260	193	2.915078	483
0.0024	1.250459	1	1.158339	170	2.905398	424
0.0026	1.250228	1	1.154588	150	2.896144	376
0.0028	1.249997	1	1.150989	135	2.887269	337
0.0030	1.249768	1	1.147524	121	2.878731	304
0.0030	1.249768	4	1.147524	753	2.878731	1,881
0.0035	1.249196	4	1.139372	599	2.858659	1,496
0.0040	1.248628	4	1.131827	491	2.840104	1,226
0.0045	1.248064	3	1.124778	412	2.822789	1,029
0.0050	1.247503	3	1.118145 -	352	2.806512	879
0.0055	1.246946	3	1.111866	305	2.791119	762
0.0060	1.246391	3	1.105894	268	2.776492	668
0.0065	1.245840	3	1.100191	238	2.762537	593
0.0070	1.245291	3	1.094727	213	2.749177	530
0.0075	1.244745 +	3	1.089476	192	2.736349	478
0.0080	1.244202	2	1.084418	174	2.724000	434
0.0085	1.243661	2	1.079535 -	159	2.712087	396
0.0090	1.243122	2	1.074810	146	2.700570	363
0.0095	1.242586	2	1.070233	135	2.689418	335
0.0100	1.242052	2	1.065790	125	2.678601	310

FUNCTIONS

the true value is larger than the tabulated value, a minus sign after a number indicates that the true value is less than the tabulated value.

<i>w</i>	<i>ir(w)</i>	$-\delta^2$	<i>ra(w)</i>	δ^2	<i>rt(w)</i>	δ^2
0.0000	0.000000	...	1.772454	...	0.785398	
0.0001	0.025065+	...	1.758368	...	0.777456	
0.0002	0.035447	...	1.752567	...	0.774187	
0.0003	0.043412	...	1.748128	652	0.771687	368
0.0004	0.050126	765	1.744395+	432	0.769585+	243
0.0005	0.056041	552	1.741113	311	0.767738	176
0.0006	0.061388	422	1.738151	238	0.766071	134
0.0007	0.066304	336	1.735432	189	0.764541	107
0.0008	0.070880	276	1.732905-	155	0.763120	88
0.0009	0.075177	231	1.730535-	130	0.761787	74
0.0010	0.079241	198	1.728296	111	0.760528	63
0.0010	0.079241	782	1.728296	440	0.760528	248
0.0012	0.086798	597	1.724140	337	0.758192	190
0.0014	0.093747	475	1.720327	268	0.756049	151
0.0016	0.100213	390	1.716786	220	0.754060	124
0.0018	0.106286	327	1.713467	184	0.752195+	104
0.0020	0.112028	280	1.710334	157	0.750436	89
0.0022	0.117488	243	1.707360	137	0.748766	77
0.0024	0.122705-	213	1.704523	120	0.747174	68
0.0026	0.127707	189	1.701806	106	0.745649	60
0.0028	0.132520	169	1.699196	95	0.744185-	54
0.0030	0.137162	153	1.696682	86	0.742774	48
0.0030	0.137162	946	1.696682	532	0.742774	300
0.0035	0.148129	753	1.690757	423	0.739451	239
0.0040	0.158332	618	1.685261	347	0.736371	196
0.0045	0.167911	519	1.680116	291	0.733488	164
0.0050	0.176966	443	1.675265-	249	0.730770	140
0.0055	0.185575+	385	1.670664	216	0.728194	122
0.0060	0.193798	338	1.666281	190	0.725741	107
0.0065	0.201680	300	1.662088	168	0.723395-	95
0.0070	0.209262	269	1.658064	151	0.721143	85
0.0075	0.216574	242	1.654191	136	0.718977	76
0.0080	0.223643	220	1.650455-	123	0.716888	69
0.0085	0.230491	201	1.646841	113	0.714869	63
0.0090	0.237138	185	1.643341	103	0.712913	58
0.0095	0.243600	170	1.639944	95	0.711015-	54
0.0100	0.249891	158	1.636643	88	0.709171	50

TABLE 1.—ROCKET

w	$rr(w)$	δ^2	$rj(w)$	δ^2	$ra^2(w)$	δ^2
0.010	1.242052	9	1.065790	497	2.678601	1,236
0.011	1.240990	8	1.057269	431	2.657876	1,071
0.012	1.239937	8	1.049183	378	2.638229	940
0.013	1.238892	8	1.041476	336	2.619525+	833
0.014	1.237854	7	1.034106	300	2.601659	745
0.015	1.236824	7	1.027038	271	2.584539	671
0.016	1.235800	7	1.020241	246	2.568093	609
0.017	1.234783	6	1.013690	224	2.552257	555
0.018	1.233772	6	1.007365—	206	2.536978	509
0.019	1.232768	6	1.001245+	190	2.522209	469
0.020	1.231770	6	0.995316	176	2.507910	434
0.020	1.231770	23	0.995316	700	2.507910	1,731
0.022	1.229791	22	0.983972	607	2.480586	1,498
0.024	1.227834	21	0.973239	533	2.454769	1,313
0.026	1.225897	20	0.963041	472	2.430272	1,163
0.028	1.223981	19	0.953317	422	2.406943	1,039
0.030	1.222084	18	0.944017	380	2.384657	935
0.032	1.220205—	17	0.935099	345	2.363309	848
0.034	1.218343	17	0.926526	315	2.342811	772
0.036	1.216499	16	0.918269	289	2.323087	708
0.038	1.214670	16	0.910302	266	2.304073	652
0.040	1.212857	15	0.902601	246	2.285712	602
0.042	1.211059	15	0.895147	229	2.267954	559
0.044	1.209276	14	0.887922	213	2.250755+	520
0.046	1.207508	14	0.880910	199	2.234078	486
0.048	1.205753	13	0.874098	187	2.217886	455
0.050	1.204011	13	0.867472	175	2.202150+	427
0.050	1.204011	82	0.867472	1,092	2.202150+	2,659
0.055	1.199714	77	0.851653	945	2.164626	2,296
0.060	1.195493	72	0.836785—	827	2.129412	2,007
0.065	1.191344	68	0.822748	732	2.096216	1,772
0.070	1.187264	65	0.809446	653	2.064799	1,579
0.075	1.183249	62	0.796800	588	2.034968	1,418
0.080	1.179295+	59	0.784744	532	2.006560	1,281
0.085	1.175401	56	0.773220	484	1.979436	1,165
0.090	1.171562	54	0.762183	443	1.953481	1,065
0.095	1.167778	52	0.751590	408	1.928593	977
0.100	1.164046	50	0.741405+	376	1.904684	901

FUNCTIONS.—(Continued)

w	$ir(w)$	$-\delta^2$	$ra(w)$	δ^2	$rt(w)$	δ^2
0.010	0.249891	629	1.636643	352	0.709171	198
0.011	0.262011	546	1.630299	305	0.705629	172
0.012	0.273581	480	1.624262	268	0.702259	151
0.013	0.284669	426	1.618495—	238	0.699042	134
0.014	0.295329	382	1.612966	213	0.695958	120
0.015	0.305606	344	1.607650+	192	0.692995—	108
0.016	0.315538	313	1.602527	174	0.690140	98
0.017	0.325156	286	1.597579	159	0.687383	89
0.018	0.334487	263	1.592789	146	0.684716	82
0.019	0.343555—	242	1.588146	135	0.682131	76
0.020	0.352380	225	1.583638	125	0.679622	70
0.020	0.352380	896	1.583638	497	0.679622	279
0.022	0.369371	778	1.574988	431	0.674810	242
0.024	0.385580	684	1.566770	378	0.670241	213
0.026	0.401102	607	1.558933	335	0.665886	189
0.028	0.416014	544	1.551433	300	0.661721	169
0.030	0.430380	491	1.544233	271	0.657724	152
0.032	0.444253	447	1.537306	246	0.653880	138
0.034	0.457679	408	1.530624	224	0.650175—	126
0.036	0.470695—	375	1.524168	206	0.646596	116
0.038	0.483335+	346	1.517917	190	0.643132	106
0.040	0.495628	321	1.511857	176	0.639775+	99
0.042	0.507600	299	1.505973	164	0.636517	92
0.044	0.519273	279	1.500252	152	0.633351	85
0.046	0.530666	261	1.494683	142	0.630270	80
0.048	0.541799	245	1.489257	133	0.627269	75
0.050	0.552685+	231	1.483964	126	0.624342	70
0.050	0.552685+	1,437	1.483964	782	0.624342	438
0.055	0.578920	1,249	1.471267	677	0.617326	380
0.060	0.603898	1,099	1.459251	594	0.610692	333
0.065	0.627771	977	1.447831	527	0.604392	295
0.070	0.650663	876	1.436941	471	0.598389	263
0.075	0.672676	792	1.426523	424	0.592650—	238
0.080	0.693895+	720	1.416531	385	0.587149	215
0.085	0.714393	658	1.406924	351	0.581864	196
0.090	0.734230	605	1.397670	322	0.576776	180
0.095	0.753462	559	1.388738	296	0.571868	166
0.100	0.772133	518	1.380103	274	0.567126	153

TABLE 1.—ROCKET

w	$rr(w)$	δ^2	$rj(w)$	δ^2	$ra^2(w)$	δ^2
0.10	1.164046	200	0.741405-	1,501	1.904684	3,593
0.11	1.156729	186	0.722140	1,294	1.859508	3,089
0.12	1.149599	174	0.704176	1,129	1.817440	2,689
0.13	1.142642	163	0.687347	996	1.778076	2,365
0.14	1.135848	154	0.671518	885	1.741088	2,099
0.15	1.129209	145	0.656578	794	1.706206	1,877
0.16	1.122714	138	0.642434	716	1.673209	1,690
0.17	1.116357	131	0.629008	650	1.641905+	1,530
0.18	1.110132	125	0.616234	592	1.612136	1,393
0.19	1.104031	119	0.604053	543	1.583764	1,274
0.20	1.098049	114	0.592416	499	1.556668	1,170
0.20	1.098049	454	0.592416	1,990	1.556668	4,664
0.22	1.086422	418	0.570604	1,704	1.505901	3,980
0.24	1.075213	386	0.550506	1,476	1.459141	3,441
0.26	1.064392	358	0.531894	1,292	1.415841	3,002
0.28	1.053929	334	0.514580	1,141	1.375559	2,645
0.30	1.043801	313	0.498412	1,016	1.337935-	2,351
0.32	1.033986	293	0.483264	910	1.302670	2,102
0.34	1.024464	276	0.469028	820	1.269514	1,891
0.36	1.015219	260	0.455615-	743	1.238255-	1,710
0.38	1.006235-	246	0.442946	676	1.208709	1,554
0.40	0.997497	233	0.430955-	617	1.180722	1,418
0.42	0.988992	222	0.419582	566	1.154155+	1,299
0.44	0.980710	211	0.408777	521	1.128890	1,194
0.46	0.972638	201	0.398494	481	1.104822	1,102
0.48	0.964767	191	0.388693	446	1.081857	1,019
0.50	0.957087	183	0.379339	414	1.059913	946
0.52	0.949590	175	0.370398	385	1.038917	879
0.54	0.942269	167	0.361843	359	1.018800	820
0.56	0.935114	160	0.353648	336	0.999505+	766
0.58	0.928120	154	0.345788	314	0.980977	717
0.60	0.921281	148	0.338243	295	0.963166	673

FUNCTIONS.—(Continued)

w	$ir(w)$	$-\delta^2$	$ra(w)$	δ^2	$rt(w)$	δ^2
0.10	0.772133	2,067	1.380103	1,094	0.567126	611
0.11	0.807954	1,797	1.363638	947	0.558092	529
0.12	0.841967	1,582	1.348125—	829	0.549590	463
0.13	0.874391	1,406	1.333445+	734	0.541552	410
0.14	0.905403	1,261	1.319503	655	0.533927	366
0.15	0.935149	1,139	1.306218	590	0.526668	329
0.16	0.963752	1,036	1.293526	534	0.519739	298
0.17	0.991317	948	1.281369	487	0.513109	271
0.18	1.017931	871	1.269699	446	0.506750—	248
0.19	1.043673	804	1.258477	410	0.500640	228
0.20	1.068608	746	1.247665—	379	0.494759	211
0.20	1.068608	2,974	1.247665—	1,510	0.494759	840
0.22	1.116291	2,584	1.227151	1,303	0.483614	725
0.24	1.161376	2,272	1.207949	1,138	0.473199	633
0.26	1.204176	2,018	1.189891	1,005	0.463421	558
0.28	1.244951	1,808	1.172842	895	0.454203	497
0.30	1.283910	1,632	1.156691	803	0.445484	446
0.32	1.321233	1,482	1.141346	725	0.437212	402
0.34	1.357071	1,353	1.126727	658	0.429344	365
0.36	1.391551	1,242	1.112769	601	0.421843	334
0.38	1.424786	1,145	1.099413	551	0.414676	306
0.40	1.456874	1,060	1.086610	508	0.407815+	282
0.42	1.487900	985	1.074316	470	0.401237	260
0.44	1.517940	918	1.062492	436	0.394920	241
0.46	1.547061	858	1.051105+	406	0.388844	225
0.48	1.575322	804	1.040124	378	0.382994	210
0.50	1.602779	756	1.029521	354	0.377353	196
0.52	1.629479	712	1.019273	332	0.371909	184
0.54	1.655466	671	1.009356	312	0.366649	173
0.56	1.680782	635	0.999753	294	0.361561	163
0.58	1.705462	602	0.990443	277	0.356637	153
0.60	1.729540	571	0.981410	262	0.351866	145

TABLE 1.—ROCKET

w	$rr(w)$	δ^2	$rj(w)$	δ^2	$ra^2(w)$	δ^2
0.60	0.921281	923	0.338243	1,837	0.963166	4,190
0.65	0.904816	838	0.320634	1,579	0.921497	3,599
0.70	0.889191	764	0.304612	1,369	0.883449	3,120
0.75	0.874332	700	0.289966	1,197	0.848536	2,728
0.80	0.860174	644	0.276522	1,053	0.816364	2,402
0.85	0.846662	594	0.264136	933	0.786604	2,129
0.90	0.833745 -	550	0.252686	831	0.758981	1,898
0.95	0.821379	511	0.242070	744	0.733262	1,700
1.00	0.809525 +	476	0.232199	668	0.709248	1,531
1.05	0.798148	444	0.222999	603	0.686769	1,384
1.10	0.787215 +	415	0.214404	547	0.665677	1,256
1.15	0.776699	389	0.206357	497	0.645844	1,143
1.20	0.766572	366	0.198808	453	0.627156	1,045
1.25	0.756810	344	0.191713	415	0.609516	957
1.30	0.747393	324	0.185034	380	0.592834	879
1.35	0.738301	306	0.178736	350	0.577034	811
1.40	0.729514	289	0.172788	322	0.562046	749
1.45	0.721016	274	0.167163	298	0.547808	693
1.50	0.712793	259	0.161836	276	0.534264	643
1.5	0.712793	1,035	0.161836	1,100	0.534264	2,566
1.6	0.697110	933	0.151991	948	0.509063	2,222
1.7	0.682363	845	0.143098	823	0.486096	1,938
1.8	0.668463	768	0.135032	718	0.465076	1,702
1.9	0.655332	701	0.127688	631	0.445764	1,502
2.0	0.642904	641	0.120976	557	0.427961	1,333
2.1	0.631118	589	0.114824	494	0.411495 -	1,189
2.2	0.619923	542	0.109168	440	0.396222	1,065
2.3	0.609270	501	0.103952	393	0.382016	957
2.4	0.599119	463	0.099131	353	0.368771	864
2.5	0.589432	430	0.094664	318	0.356391	783
2.6	0.580176	400	0.090515 +	287	0.344797	711
2.7	0.571319	372	0.086655 -	260	0.333915 -	648
2.8	0.562836	348	0.083055 -	236	0.323683	592
2.9	0.554701	325	0.079691	215	0.314044	543
3.0	0.546891	304	0.076544	197	0.304948	499

FUNCTIONS.—(Continued)

w	$ir(w)$	$-\delta^2$	$ra(w)$	δ^2	$rt(w)$	δ^2
0.60	1.729540	3,560	0.981410	1,633	0.351866	904
0.65	1.787296	3,145	0.959947	1,430	0.340557	791
0.70	1.841895—	2,802	0.939919	1,263	0.330042	698
0.75	1.893680	2,515	0.921160	1,124	0.320229	621
0.80	1.942942	2,272	0.903529	1,007	0.311038	556
0.85	1.989926	2,064	0.886907	907	0.302405+	500
0.90	2.034840	1,884	0.871195+	822	0.294275—	453
0.95	2.077866	1,728	0.856307	748	0.286598	412
1.00	2.119161	1,591	0.842169	684	0.279335—	376
1.05	2.158862	1,470	0.828715+	627	0.272448	345
1.10	2.197090	1,363	0.815890	578	0.265908	317
1.15	2.233953	1,267	0.803644	533	0.259685+	293
1.20	2.269548	1,182	0.791932	494	0.253756	271
1.25	2.303959	1,105	0.780715—	459	0.248098	251
1.30	2.337263	1,035	0.769957	427	0.242692	234
1.35	2.369531	972	0.759628	399	0.237521	218
1.40	2.400826	915	0.749697	373	0.232568	204
1.45	2.431205—	863	0.740141	350	0.227819	191
1.50	2.460720	815	0.730934	328	0.223261	179
1.5	2.460720	3,255	0.730934	1,311	0.223261	714
1.6	2.517347	2,918	0.713487	1,162	0.214671	631
1.7	2.571046	2,633	0.697206	1,036	0.206714	561
1.8	2.622105+	2,387	0.681965—	929	0.199322	503
1.9	2.670771	2,175	0.667656	838	0.192433	451
2.0	2.717257	1,989	0.654187	758	0.185997	407
2.1	2.761749	1,827	0.641479	689	0.179969	369
2.2	2.804411	1,684	0.629461	629	0.174311	336
2.3	2.845385—	1,557	0.618074	576	0.168990	306
2.4	2.884799	1,445	0.607265—	529	0.163976	280
2.5	2.922766	1,343	0.596985+	487	0.159242	257
2.6	2.959389	1,253	0.587194	450	0.154766	237
2.7	2.994757	1,170	0.577854	417	0.150527	218
2.8	3.028953	1,096	0.568931	387	0.146507	202
2.9	3.062052	1,029	0.560396	360	0.142689	187
3.0	3.094121	968	0.552221	335	0.139059	174

TABLE 1.—ROCKET

w	$rr(w)$	δ^2	$rj(w)$	δ^2	$ra^2(w)$	δ^2
3.0	0.546891	1,215	0.076544	784	0.304948	1,988
3.2	0.532166	1,072	0.070824	658	0.288216	1,690
3.4	0.518517	951	0.065766	557	0.273185+	1,448
3.6	0.505822	847	0.061269	476	0.259610	1,250
3.8	0.493977	759	0.057251	409	0.247291	1,087
4.0	0.482894	683	0.053644	353	0.236064	950
4.2	0.472496	617	0.050392	307	0.225792	836
4.4	0.462717	560	0.047449	268	0.216358	739
4.6	0.453499	510	0.044774	236	0.207666	656
4.8	0.444791	465	0.042337	208	0.199632	585
5.0	0.436550—	426	0.040108	184	0.192184	524
5.2	0.428736	391	0.038064	164	0.185263	471
5.4	0.421313	360	0.036184	146	0.178814	425
5.6	0.414252	333	0.034451	131	0.172792	385
5.8	0.407524	308	0.032850—	118	0.167155—	350
6.0	0.401104	286	0.031366	106	0.161868	318
6.2	0.394971	265	0.029988	96	0.156901	291
6.4	0.389103	247	0.028707	87	0.152225—	266
6.6	0.383482	231	0.027513	79	0.147815+	244
6.8	0.378092	215	0.026398	72	0.143651	225
7.0	0.372918	202	0.025354	66	0.139711	207
7.2	0.367946	189	0.024377	60	0.135979	191
7.4	0.363163	178	0.023460	55	0.132438	177
7.6	0.358558	167	0.022598	51	0.129075—	164
7.8	0.354121	157	0.021787	47	0.125876	153
8.0	0.349841	148	0.021022	43	0.122830	142
8.0	0.349841	925	0.021022	267	0.122830	885
8.5	0.339772	804	0.019292	220	0.115818	745
9.0	0.330512	704	0.017783	183	0.109555—	633
9.5	0.321959	620	0.016459	153	0.103928	542
10.0	0.314027	549	0.015290	130	0.098847	468
10.5	0.306647	489	0.014252	111	0.094235+	406
11.0	0.299757	438	0.013324	95	0.090032	355
11.5	0.293307	394	0.012493	82	0.086185—	312
12.0	0.287251	356	0.011743	71	0.082651	276
12.5	0.281552	322	0.011065—	62	0.079394	245
13.0	0.276176	293	0.010449	54	0.076382	218

FUNCTIONS.—(Continued)

w	$ir(w)$	$-\delta^2$	$ra(w)$	δ^2	$ri(w)$	δ^2
3.0	3.094121	3,864	0.552221	1,343	0.139059	693
3.2	3.155409	3,436	0.536858	1,171	0.132308	601
3.4	3.213248	3,075	0.522671	1,031	0.126161	525
3.6	3.268002	2,768	0.509519	913	0.120541	461
3.8	3.319980	2,505	0.497284	813	0.115384	407
4.0	3.369446	2,277	0.485865	728	0.110636	361
4.2	3.416630	2,079	0.475176	655	0.106249	322
4.4	3.461730	1,906	0.465143	591	0.102186	288
4.6	3.504921	1,752	0.455704	536	0.098412	259
4.8	3.546356	1,617	0.446802	488	0.094898	234
5.0	3.586171	1,497	0.438389	446	0.091618	211
5.2	3.624486	1,390	0.430422	408	0.088550 +	192
5.4	3.661410	1,293	0.422864	375	0.085675 -	175
5.6	3.697039	1,207	0.415682	345	0.082974	160
5.8	3.731459	1,128	0.408846	319	0.080434	146
6.0	3.764749	1,057	0.402329	295	0.078040	134
6.2	3.796982	993	0.396107	274	0.075780	123
6.4	3.828220	934	0.390160	255	0.073644	114
6.6	3.858523	880	0.384468	237	0.071622	105
6.8	3.887945 -	831	0.379013	221	0.069705 -	97
7.0	3.916535 +	786	0.373779	207	0.067885 -	90
7.2	3.944339	744	0.368753	194	0.066155 -	84
7.4	3.971399	706	0.363920	182	0.064509	78
7.6	3.997752	670	0.359270	171	0.062941	73
7.8	4.023435 +	637	0.354790	161	0.061445 +	68
8.0	4.048481	606	0.350472	151	0.060018	63
8.0	4.048481	3,782	0.350472	944	0.060018	394
8.5	4.108503	3,361	0.340320	818	0.056717	335
9.0	4.165151	3,007	0.330990	715	0.053753	287
9.5	4.218783	2,705	0.322379	629	0.051078	248
10.0	4.269702	2,446	0.314399	556	0.048652	215
10.5	4.318167	2,223	0.306978	495	0.046442	188
11.0	4.364405 -	2,029	0.300053	443	0.044421	165
11.5	4.408608	1,859	0.293572	398	0.042566	146
12.0	4.450949	1,709	0.287491	359	0.040858	130
12.5	4.491577	1,577	0.281769	325	0.039280	116
13.0	4.530626	1,460	0.276373	296	0.037817	103

TABLE 1.—ROCKET

w	$rr(w)$	δ^2	$rj(w)$	δ^2	$ra^2(w)$	δ^2
13.0	0.276176	293	0.010449	54	0.076382	218
13.5	0.271093	268	0.009888	48	0.073589	195
14.0	0.266279	245	0.009375 +	42	0.070993	176
14.5	0.261711	225	0.008905 -	38	0.068572	158
15.0	0.257369	207	0.008472	34	0.066310	143
15.5	0.253234	191	0.008073	30	0.064192	130
16.0	0.249291	177	0.007704	27	0.062205 +	119
16.5	0.245525 -	164	0.007363	24	0.060337	108
17.0	0.241924	153	0.007045 +	22	0.058577	99
17.5	0.238476	142	0.006750 +	20	0.056916	91
18.0	0.235170	133	0.006475 -	18	0.055347	84
18.5	0.231998	124	0.006218	16	0.053862	77
19.0	0.228950 -	116	0.005977	15	0.052454	71
19.5	0.226018	109	0.005751	14	0.051117	66
20.0	0.223196	103	0.005540	13	0.049847	61
20.5	0.220477	97	0.005341	12	0.048638	57
21.0	0.217854	91	0.005153	11	0.047487	53
21.5	0.215322	86	0.004976	10	0.046388	49
22.0	0.212876	81	0.004809	9	0.045339	46
22.5	0.210511	77	0.004651	8	0.044337	43
23.0	0.208223	73	0.004502	8	0.043377	41
23.5	0.206008	69	0.004360	7	0.042458	38
24.0	0.203862	65	0.004226	7	0.041578	36
24.5	0.201782	62	0.004098	6	0.040733	34
25.0	0.199763	59	0.003977	6	0.039921	32
25.5	0.197804	56	0.003861	5	0.039141	30
26.0	0.195901	54	0.003751	5	0.038391	28
26.5	0.194052	51	0.003646	5	0.037670	27
27.0	0.192254	49	0.003546	4	0.036974	25
27.5	0.190506	47	0.003450 +	4	0.036304	24
28.0	0.188803	45	0.003359	4	0.035658	23
28.5	0.187146	43	0.003271	4	0.035034	21
29.0	0.185531	41	0.003188	4	0.034432	20
29.5	0.183958	39	0.003107	3	0.033850 +	19
30.0	0.182423	38	0.003030	3	0.033288	18
30.5	0.180927	36	0.002957	3	0.032743	17
31.0	0.179466	35	0.002886	3	0.032217	17
31.5	0.178041	33	0.002818	3	0.031706	16
32.0	0.176648	32	0.002752	2	0.031212	15

FUNCTIONS.—(Continued)

w	$ir(w)$	$-\delta^2$	$ra(w)$	δ^2	$rt(w)$	δ^2
13.0	4.530626	1,460	0.276373	296	0.037817	103
13.5	4.568212	1,355	0.271274	270	0.036458	93
14.0	4.604441	1,261	0.266444	247	0.035193	84
14.5	4.639408	1,176	0.261863	227	0.034011	76
15.0	4.673197	1,100	0.257508	209	0.032906	69
15.5	4.705884	1,030	0.253362	193	0.031869	63
16.0	4.737540	968	0.249410	178	0.030895+	57
16.5	4.768227	911	0.245635+	165	0.029978	53
17.0	4.798002	858	0.242026	154	0.029114	48
17.5	4.826919	810	0.238571	143	0.028298	44
18.0	4.855024	766	0.235260	133	0.027526	41
18.5	4.882363	726	0.232081	125	0.026794	38
19.0	4.908976	688	0.229028	117	0.026100	35
19.5	4.934900	654	0.226092	110	0.025441	32
20.0	4.960170	621	0.223265-	103	0.024815-	30
20.5	4.984818	592	0.220541	97	0.024218	28
21.0	5.008875	564	0.217915-	91	0.023649	26
21.5	5.032367	538	0.215379	86	0.023106	24
22.0	5.055320	514	0.212930	81	0.022587	23
22.5	5.077760	492	0.210563	77	0.022091	21
23.0	5.099707	470	0.208272	73	0.021616	20
23.5	5.121184	451	0.206054	69	0.021161	19
24.0	5.142210	432	0.203906	66	0.020725-	18
24.5	5.162803	415	0.201823	62	0.020306	16
25.0	5.182982	399	0.199803	59	0.019904	16
25.5	5.202761	383	0.197842	56	0.019517	15
26.0	5.222158	368	0.195937	54	0.019145+	14
26.5	5.241186	355	0.194086	51	0.018787	13
27.0	5.259858	342	0.192287	49	0.018442	12
27.5	5.278189	330	0.190537	47	0.018109	12
28.0	5.296190	318	0.188833	45	0.017788	11
28.5	5.313873	307	0.187175-	43	0.017479	11
29.0	5.331249	296	0.185559	41	0.017179	10
29.5	5.348329	286	0.183984	39	0.016890	10
30.0	5.365122	277	0.182449	38	0.016611	9
30.5	5.381638	268	0.180951	36	0.016340	9
31.0	5.397886	260	0.179490	35	0.016078	8
31.5	5.413874	251	0.178063	33	0.015824	8
32.0	5.429611	244	0.176670	32	0.015579	8

TABLE 1.—ROCKET

w	$rr(w)$	δ^2	$rj(w)$	δ^2	$ra^2(w)$	δ^2
32.0	0.176648	32	0.002752	2	0.031212	15
32.5	0.175288	31	0.002689	2	0.030733	14
33.0	0.173959	30	0.002629	2	0.030269	14
33.5	0.172659	29	0.002570	2	0.029818	13
34.0	0.171388	28	0.002514	2	0.029380	13
34.5	0.170145 -	27	0.002460	2	0.028955 +	12
35.0	0.168928	26	0.002407	2	0.028542	12
35.5	0.167737	25	0.002357	2	0.028141	11
36.0	0.166571	24	0.002308	2	0.027751	11
36.5	0.165429	23	0.002261	2	0.027372	10
37.0	0.164309	22	0.002216	2	0.027003	10
37.5	0.163213	22	0.002172	1	0.026643	9
38.0	0.162138	21	0.002129	1	0.026293	9
38.5	0.161084	20	0.002088	1	0.025952	9
39.0	0.160050 -	20	0.002048	1	0.025620	8
39.5	0.159035 +	19	0.002009	1	0.025296	8
40.0	0.158040	18	0.001972	1	0.024981	8
40.5	0.157063	18	0.001936	1	0.024673	7
41.0	0.156104	17	0.001900	1	0.024372	7
41.5	0.155163	17	0.001866	1	0.024079	7
42.0	0.154238	16	0.001833	1	0.023793	7
42.5	0.153330	16	0.001801	1	0.023513	6
43.0	0.152437	15	0.001770	1	0.023240	6
43.5	0.151560	15	0.001739	1	0.022973	6
44.0	0.150698	15	0.001710	1	0.022713	6
44.5	0.149850 -	14	0.001681	1	0.022458	6
45.0	0.149016	14	0.001653	1	0.022209	5
45.5	0.148196	13	0.001626	1	0.021965 -	5
46.0	0.147390	13	0.001600	1	0.021726	5
46.5	0.146596	13	0.001574	1	0.021493	5
47.0	0.145816	12	0.001549	1	0.021265 -	5
47.5	0.145047	12	0.001525 -	1	0.021041	5
48.0	0.144291	12	0.001501	1	0.020822	5
48.5	0.143546	11	0.001478	1	0.020608	4
49.0	0.142813	11	0.001455 +	1	0.020398	4
49.5	0.142090	11	0.001434	1	0.020192	4
50.0	0.141379	11	0.001412	1	0.019990	4
50.5	0.140678	10	0.001391	1	0.019792	4
51.0	0.139988	10	0.001371	0	0.019598	4

FUNCTIONS.—(Continued)

w	$ir(w)$	$-\delta^2$	$ra(w)$	δ^2	$rt(w)$	δ^2
32.0	5.429611	244	0.176670	32	0.015579	8
32.5	5.445104	236	0.175309	31	0.015340	7
33.0	5.460361	229	0.173979	30	0.015109	7
33.5	5.475388	222	0.172678	29	0.014885	7
34.0	5.490194	216	0.171407	28	0.014667	6
34.5	5.504783	210	0.170163	27	0.014456	6
35.0	5.519163	204	0.168945+	26	0.014250+	6
35.5	5.533339	198	0.167754	25	0.014050+	6
36.0	5.547317	193	0.166587	24	0.013856	5
36.5	5.561103	187	0.165444	23	0.013667	5
37.0	5.574701	182	0.164324	22	0.013483	5
37.5	5.588117	177	0.163227	22	0.013304	5
38.0	5.601355+	173	0.162152	21	0.013130	4
38.5	5.614421	168	0.161097	20	0.012960	4
39.0	5.627318	164	0.160063	20	0.012795-	4
39.5	5.640050+	160	0.159048	19	0.012633	4
40.0	5.652623	156	0.158052	18	0.012476	4
40.5	5.665040	152	0.157075+	18	0.012323	4
41.0	5.677305-	149	0.156116	17	0.012173	4
41.5	5.689421	145	0.155174	17	0.012027	3
42.0	5.701392	142	0.154249	16	0.011884	3
42.5	5.713221	138	0.153340	16	0.011745-	3
43.0	5.724912	135	0.152447	15	0.011609	3
43.5	5.736469	132	0.151570	15	0.011476	3
44.0	5.747893	129	0.150707	15	0.011346	3
44.5	5.759188	126	0.149859	14	0.011219	3
45.0	5.770357	123	0.149025+	14	0.011094	3
45.5	5.781403	121	0.148205+	13	0.010973	3
46.0	5.792328	118	0.147399	13	0.010854	3
46.5	5.803135+	115	0.146605-	13	0.010737	2
47.0	5.813827	113	0.145824	12	0.010624	2
47.5	5.824406	111	0.145055+	12	0.010512	2
48.0	5.834873	108	0.144299	12	0.010403	2
48.5	5.845233	106	0.143554	11	0.010296	2
49.0	5.855486	104	0.142820	11	0.010191	2
49.5	5.865635+	102	0.142098	11	0.010088	2
50.0	5.875683	100	0.141386	11	0.009988	2
50.5	5.885630	98	0.140685	10	0.009889	2
51.0	5.895480	96	0.139994	10	0.009792	2

TABLE 2.—VALUES OF $E_2(p) = p(1 - p^2)/6$ TO 5 DECIMAL PLACES

p	0	1	2	3	4	5	6	7	8	9
	0.0	0.0	0.0	0.0	0.0	0.0	0.0	0.0	0.0	0.0
0.00	0000	0017	0033	0050	0067	0083	0100	0117	0133	0150
0.01	0167	0183	0200	0217	0233	0250	0267	0283	0300	0317
0.02	0333	0350	0366	0383	0400	0416	0433	0450	0466	0483
0.03	0500	0516	0533	0549	0566	0583	0599	0616	0632	0649
0.04	0666	0682	0699	0715	0732	0748	0765	0782	0798	0815
0.05	0831	0848	0864	0881	0897	0914	0930	0947	0963	0980
0.06	0996	1013	1029	1046	1062	1079	1095	1112	1128	1145
0.07	1161	1177	1194	1210	1227	1243	1259	1276	1292	1308
0.08	1325	1341	1357	1374	1390	1406	1423	1439	1455	1472
0.09	1488	1504	1520	1537	1553	1569	1585	1601	1618	1634
0.10	1650	1666	1682	1698	1715	1731	1747	1763	1779	1795
0.11	1811	1827	1843	1859	1875	1891	1907	1923	1939	1955
0.12	1971	1987	2003	2019	2035	2051	2067	2083	2098	2114
0.13	2130	2146	2162	2177	2193	2209	2225	2240	2256	2272
0.14	2288	2303	2319	2335	2350	2366	2381	2397	2413	2428
0.15	2444	2459	2475	2490	2506	2521	2537	2552	2568	2583
0.16	2598	2614	2629	2644	2660	2675	2690	2706	2721	2736
0.17	2751	2767	2782	2797	2812	2827	2842	2858	2873	2888
0.18	2903	2918	2933	2948	2963	2978	2993	3008	3023	3037
0.19	3052	3067	3082	3097	3112	3126	3141	3156	3171	3185
0.20	3200	3215	3229	3244	3259	3273	3288	3302	3317	3331
0.21	3346	3360	3375	3389	3403	3418	3432	3446	3461	3475
0.22	3489	3503	3518	3532	3546	3560	3574	3588	3602	3617
0.23	3631	3645	3659	3673	3686	3700	3714	3728	3742	3756
0.24	3770	3783	3797	3811	3825	3838	3852	3866	3879	3893
0.25	3906	3920	3933	3947	3960	3974	3987	4000	4014	4027
0.26	4040	4054	4067	4080	4093	4107	4120	4133	4146	4159
0.27	4172	4185	4198	4211	4224	4237	4250	4262	4275	4288
0.28	4301	4314	4326	4339	4352	4364	4377	4389	4402	4414
0.29	4427	4439	4452	4464	4476	4489	4501	4513	4526	4538
0.30	4550	4562	4574	4586	4598	4610	4622	4634	4646	4658
0.31	4670	4682	4694	4706	4717	4729	4741	4752	4764	4776
0.32	4787	4799	4810	4822	4833	4845	4856	4867	4879	4890
0.33	4901	4912	4923	4935	4946	4957	4968	4979	4990	5001
0.34	5012	5022	5033	5044	5055	5066	5076	5087	5098	5108

TABLE 2.—VALUES OF $E_2(p) = p(1 - p^2)/6$ TO 5 DECIMAL PLACES.—(Continued)

<i>p</i>	0	1	2	3	4	5	6	7	8	9
	0.0	0.0	0.0	0.0	0.0	0.0	0.0	0.0	0.0	0.0
0.35	5119	5129	5140	5150	5161	5171	5181	5192	5202	5212
0.36	5222	5233	5243	5253	5263	5273	5283	5293	5303	5313
0.37	5322	5332	5342	5352	5361	5371	5381	5390	5400	5409
0.38	5419	5428	5438	5447	5456	5466	5475	5484	5493	5502
0.39	5511	5520	5529	5538	5547	5556	5565	5574	5583	5591
0.40	5600	5609	5617	5626	5634	5643	5651	5660	5668	5676
0.41	5685	5693	5701	5709	5717	5725	5733	5741	5749	5757
0.42	5765	5773	5781	5789	5796	5804	5812	5819	5827	5834
0.43	5842	5849	5856	5864	5871	5878	5885	5892	5900	5907
0.44	5914	5921	5927	5934	5941	5948	5955	5961	5968	5975
0.45	5981	5988	5994	6001	6007	6013	6020	6026	6032	6038
0.46	6044	6050	6056	6062	6068	6074	6080	6086	6092	6097
0.47	6103	6109	6114	6120	6125	6130	6136	6141	6146	6152
0.48	6157	6162	6167	6172	6177	6182	6187	6192	6196	6201
0.49	6206	6210	6215	6220	6224	6229	6233	6237	6242	6246
0.50	6250	6254	6258	6262	6266	6270	6274	6278	6282	6285
0.51	6289	6293	6296	6300	6303	6307	6310	6314	6317	6320
0.52	6323	6326	6329	6332	6335	6338	6341	6344	6347	6349
0.53	6352	6355	6357	6360	6362	6364	6367	6369	6371	6373
0.54	6376	6378	6380	6382	6384	6385	6387	6389	6391	6392
0.55	6394	6395	6397	6398	6399	6401	6402	6403	6404	6405
0.56	6406	6407	6408	6409	6410	6411	6411	6412	6412	6413
0.57	6413	6414	6414	6414	6415	6415	6415	6415	6415	6415
0.58	6415	6415	6414	6414	6414	6413	6413	6412	6412	6411
0.59	6410	6410	6409	6408	6407	6406	6405	6404	6403	6401
0.60	6400	6399	6397	6396	6394	6393	6391	6389	6387	6386
0.61	6384	6382	6380	6378	6375	6373	6371	6369	6366	6364
0.62	6361	6359	6356	6353	6350	6348	6345	6342	6339	6336
0.63	6333	6329	6326	6323	6319	6316	6312	6309	6305	6301
0.64	6298	6294	6290	6286	6282	6278	6274	6269	6265	6261
0.65	6256	6252	6247	6243	6238	6233	6228	6223	6218	6213
0.66	6208	6203	6198	6193	6187	6182	6177	6171	6165	6160
0.67	6154	6148	6142	6136	6130	6124	6118	6112	6106	6099
0.68	6093	6086	6080	6073	6066	6060	6053	6046	6039	6032
0.69	6025	6018	6010	6003	5996	5988	5981	5973	5966	5958

TABLE 2.—VALUES OF $E_2(p) = p(1 - p^2)/6$ TO 5 DECIMAL PLACES.—(Continued)

p	0	1	2	3	4	5	6	7	8	9
	0.0	0.0	0.0	0.0	0.0	0.0	0.0	0.0	0.0	0.0
0.70	5950	5942	5934	5926	5918	5910	5902	5893	5885	5877
0.71	5868	5860	5851	5842	5833	5825	5816	5807	5798	5788
0.72	5779	5770	5761	5751	5742	5732	5722	5713	5703	5693
0.73	5683	5673	5663	5653	5643	5632	5622	5611	5601	5590
0.74	5580	5569	5558	5547	5536	5525	5514	5503	5492	5480
0.75	5469	5457	5446	5434	5422	5411	5399	5387	5375	5363
0.76	5350	5338	5326	5313	5301	5288	5276	5263	5250	5237
0.77	5224	5211	5198	5185	5172	5159	5145	5132	5118	5105
0.78	5091	5077	5063	5049	5035	5021	5007	4993	4978	4964
0.79	4949	4935	4920	4905	4891	4876	4861	4846	4831	4815
0.80	4800	4785	4769	4754	4738	4722	4707	4691	4675	4659
0.81	4643	4626	4610	4594	4577	4561	4544	4528	4511	4494
0.82	4477	4460	4443	4426	4409	4391	4374	4357	4339	4321
0.83	4304	4286	4268	4250	4232	4214	4195	4177	4159	4140
0.84	4122	4103	4084	4065	4046	4027	4008	3989	3970	3951
0.85	3931	3912	3892	3872	3853	3833	3813	3793	3773	3753
0.86	3732	3712	3692	3671	3650	3630	3609	3588	3567	3546
0.87	3525	3504	3482	3461	3440	3418	3396	3375	3353	3331
0.88	3309	3287	3265	3242	3220	3197	3175	3152	3130	3107
0.89	3084	3061	3038	3015	2991	2968	2945	2921	2897	2874
0.90	2850	2826	2802	2778	2754	2730	2705	2681	2656	2632
0.91	2607	2582	2557	2533	2507	2482	2457	2432	2406	2381
0.92	2355	2330	2304	2278	2252	2226	2200	2173	2147	2121
0.93	2094	2067	2041	2014	1987	1960	1933	1906	1878	1851
0.94	1824	1796	1768	1741	1713	1685	1657	1629	1600	1572
0.95	1544	1515	1487	1458	1429	1400	1371	1342	1313	1284
0.96	1254	1225	1195	1166	1136	1106	1076	1046	1016	0986
0.97	0955	0925	0894	0864	0833	0802	0771	0740	0709	0678
0.98	0647	0615	0584	0552	0521	0489	0457	0425	0393	0361
0.99	0328	0296	0263	0231	0198	0165	0133	0100	0066	0033

APPENDIX 1

A SIMPLIFIED THEORY OF FLOW THROUGH A NOZZLE

The theory presented here is called the "one-dimensional theory of flow through a nozzle." It gives surprisingly good results provided the cross-sectional area of the nozzle does not change too rapidly as one proceeds along the channel. The chief weakness of the treatment is that, as a consequence of the fact that it is one-dimensional, it cannot provide a basis for nozzle design.

The theory is based on a set of assumptions which, though mostly inexact, are not seriously in error for most rockets, namely,

1. The rocket is not accelerating.
2. Flow through the nozzle is steady.
3. The gas is homogeneous before entry into the nozzle.
4. Flow through the nozzle is adiabatic.
5. No changes of phase or chemical reactions take place during flow through the nozzle.
6. No shock waves occur within the nozzle.
7. There are no viscous effects.
8. The gas is ideal.
9. All sidewise components of motion are zero and, for any given cross section, the conditions are the same at all points of the cross section.

As a result of the second and ninth assumptions, the conditions in the nozzle are functions of only one variable, namely, the distance traveled along the nozzle. It is for this reason that this is called the one-dimensional theory of flow.

The condition of the gas is given by specifying its pressure P , its density ρ , its temperature T , and its velocity with respect to the rocket v . As mentioned in the ninth assumption, these quantities are the same across any cross section, although they vary from cross section to cross section. The area of the cross section is denoted by A .

Conditions in the chamber, at the throat, and at the exit are denoted by the subscripts c , t , and e .

The various physical properties of ideal gases which we quote throughout the derivation are well known, but we have supplied references for the benefit of nontechnical readers.

Since the gas is assumed ideal, we have

$$P = nRT\rho \quad (\text{A1.1})$$

[see Reference 4, page 6, Eq. (1.12)].

The rate at which mass passes through any given cross section is easily seen to be ρAv . Since the flow is steady, this must be the same as the rate at which propellant fuel is being burnt, and so we have

$$\rho Av = \dot{m} \quad (\text{A1.2})$$

where a dot over a letter indicates a derivative with respect to time and m is the mass of propellant fuel already burnt.

The energy per unit mass of the gas is composed of the heat energy $C_P T + u_0$ [see Reference 4, page 47, Eq. (3.28)] plus the kinetic energy $\frac{1}{2}v^2$. Since the flow is adiabatic and nonviscous, the total energy $C_P T + u_0 + \frac{1}{2}v^2$ must be constant and hence equal to its value in any specified region, such as the chamber. Thus

$$C_P T + u_0 + \frac{1}{2}v^2 = C_P T_c + u_0 + \frac{1}{2}v_c^2$$

This simplifies to

$$2C_P T + v^2 = 2C_P T_c + v_c^2 \quad (\text{A1.3})$$

Since the flow is adiabatic and the gas is homogeneous, P/ρ^γ is a constant [see Reference 4, page 49, Eq. (3.38)]. So

$$\frac{P}{\rho^\gamma} = \frac{P_c}{\rho_c^\gamma} \quad (\text{A1.4})$$

Suppose we are given the conditions in the chamber P_c , ρ_c , T_c , and v_c , the basic problem is to determine P , ρ , T , and v as functions of A . In particular we wish the values of P_e and v_e . As it happens, P , ρ , and T decrease and v increases as the gas flows through the nozzle, whereas A first decreases and then increases. This situation seems highly implausible, but it is necessitated by the four equations given above if one is to get a large value of v_e . It is for this reason that nozzles are made the shape they are, namely, first contracting and then expanding. However, this circumstance has the consequence that P , ρ , T , and v are double-valued functions of A . To avoid these double-valued functions as far as possible, it is usual to express conditions in the nozzle as functions of some parameter other than A . Accordingly, we undertake to express P , ρ , v , and A as functions of T .

(A1.3) gives us v as a function of T . Substituting for P from (A1.1) into (A1.4) gives us ρ as a function of T , namely,

$$\rho = \rho_c \left(\frac{T}{T_c} \right)^{1/(\gamma-1)} \quad (\text{A1.5})$$

Substituting for ρ from (A1.1) into (A1.4) gives us P as a function of T , namely,

$$P = P_c \left(\frac{T}{T_c} \right)^{\gamma(\gamma-1)} \quad (\text{A1.6})$$

To find A as a function of T , we substitute for ρ and v from (A1.5) and (A1.3) into (A1.2), with the result

$$A = \frac{\dot{m}}{\rho_c} \left(\frac{T_c}{T} \right)^{\nu(\gamma-1)} \frac{1}{\sqrt{2C_P T_c + v_c^2 - 2C_P T}} \quad (\text{A1.7})$$

We can now consider in detail how P , ρ , T , v , and A change as we proceed down the channel. In the chamber, the velocity v_c is quite small. However, we wish the velocity v_e at the exit to be very large. So we wish v to increase as we proceed down the channel. By (A1.3), T must decrease. So by (A1.5) and (A1.6), both ρ and P must decrease. The behavior of A requires more attention.

If one uses (A1.7) to graph A as a function of T for positive T , using the curve-plotting methods of calculus, we find that A has a single minimum and increases to infinity for the two values $T = 0$ and

$$T = \frac{2C_P T_c + v_c^2}{2C_P}$$

We wish to find where we can be on this graph relative to the minimum. At the minimum point,

$$\frac{dA}{dT} = 0$$

so that

$$2C_P T_c + v_c^2 - 2C_P T = (\gamma - 1)C_P T \quad (\text{A1.8})$$

So, by (A1.3),

$$v^2 = (\gamma - 1)C_P T \quad (\text{A1.9})$$

However $C_P - C_V = nR$ [see Reference 4, page 44, Eq. (3.20)] and $\gamma = C_P/C_V$ [see Reference 4, page 49, line 22], so that

$$C_P = \frac{\gamma nR}{\gamma - 1}$$

Thus (A1.9) takes the form

$$v^2 = \gamma nRT \quad (\text{A1.10})$$

However [see Reference 4, p. 49, Eq. (3.40)], the velocity of sound at temperature T is $\sqrt{\gamma nRT}$. Thus, at the minimum point of the graph, v is equal to the local velocity of sound. To the right of this point, T is greater, so that v is less and the local velocity of sound, $\sqrt{\gamma nRT}$, is

greater. Thus v is less than the local velocity of sound to the right of the minimum point of the graph. Similar reasoning shows that to the left of the minimum point v must exceed the local velocity of sound.

In the chamber, the velocity v_c is quite small, far below the local velocity of sound. So chamber conditions must correspond to a point A_c on the right side of the minimum. To have v_c quite large, well above the local velocity of sound, the exit conditions must correspond to a point A_e on the left side of the minimum.

Thus we have proved that an efficient nozzle must have a cross section of minimum area between the chamber and the exit. This cross section of minimum area is just the throat, of course, so that (A1.8) and (A1.10) take the forms

$$T_t = \frac{2C_P T_c + v_c^2}{(\gamma + 1)C_P} \quad (\text{A1.11})$$

$$v_t^2 = \gamma n R T_t \quad (\text{A1.12})$$

We have proved incidentally that at the throat the velocity attains the local velocity of sound, that before the throat the velocity is less than the local velocity of sound, and that after the throat the velocity is greater than the local velocity of sound.

To compute v_e and P_e , one can use the following procedure. Put $A = A_e$ in (A1.7). Solve this for T_e , which will be the smaller of the two possible solutions. Then (A1.6) and (A1.3) give P_e and v_e .

After the gas leaves the nozzle it continues to expand, with resulting increase in velocity. In a vacuum it could expand indefinitely, but the velocity would not increase indefinitely. To see this, let the gas expand until P , ρ , and T are all zero. Then, by (A1.3), it would have attained the velocity

$$\sqrt{2C_P T_c + v_c^2} \quad (\text{A1.13})$$

This is often called the "ultimate gas velocity" and is the maximum velocity that a gas could attain by expansion from the initial conditions in the chamber.

For a given propellant, T_c is independent of the operating pressure P_c . Also v_c is quite small and is independent of the operating pressure, although somewhat dependent on the inside proportions of the rocket. So, by (A1.11) and (A1.12), the throat temperature and the throat velocity are also independent of the operating pressure. Thence, by (A1.6), the throat pressure is proportional to the operating pressure. Consequently, by (A1.1), the throat density is proportional to the operating pressure. So, finally, $v_t \rho_t$ is proportional to P_c . The constant of proportionality is known as the "discharge coefficient" and

is denoted by C_D . Therefore we have

$$v_i \rho_i = C_D P_c$$

However, by (A1.2),

$$\rho_i A_i v_i = \dot{m}$$

So

$$\dot{m} = C_D P_c A_i \quad (\text{A1.14})$$

Reviewing our reasoning, we see that C_D depends on the kind of propellant and the rocket proportions. However, for a given kind of propellant, C_D is nearly constant, depending very slightly on the inside proportions of the rocket. So for any given propellant, the mass rate of discharge \dot{m} through a nozzle is nearly proportional to the product of chamber pressure and throat area, and for a fixed design of rocket and nozzle \dot{m} is strictly proportional to the chamber pressure.

Let us now have a fixed design of rocket and nozzle and a given propellant. Then C_D is a constant. So by substituting \dot{m} from (A1.14) and ρ_c from (A1.1) into (A1.7), we get

$$A = nRT_c C_D A_i \left(\frac{T_c}{T} \right)^{1/(\gamma-1)} \frac{1}{\sqrt{2C_P T_c + v_c^2 - 2C_P T}} \quad (\text{A1.15})$$

So for any value of A , the corresponding value of T is independent of P_c . In particular, T_c is independent of P_c . So, by (A1.3), v_c is independent of P_c , and by (A1.6), P_c is proportional to P_c .

We conclude with a numerical example. To avoid complications, the computations are carried out in consistent CGS units. A typical set of data might be as follows:

From thermodynamic considerations of the chemistry of the propellant,

$$\begin{aligned} T_c &= 3,200^\circ K \\ n &= 0.0365 \\ \gamma &= 1.2 \\ R &= 8.3156 \times 10^7 \end{aligned}$$

From measurement of the rocket,

$$\begin{aligned} A_c &= 14.19 \text{ in.}^2 = 91.6 \text{ cm}^2 \\ A_i &= 2.636 \text{ in.}^2 = 17.0 \text{ cm}^2 \\ A_e &= 5.564 \text{ in.}^2 = 35.9 \text{ cm}^2 \end{aligned}$$

From measurements during burning,

$$\begin{aligned} P_c &= 2,000 \text{ lb/in.}^2 = 1.38 \times 10^8 \text{ dynes/cm}^2 \\ \text{Time of burning} &= 0.141 \text{ sec} \end{aligned}$$

The initial weight of propellant is 4.8 lb = 2,180 gm.

Since the rocket burns 2,180 gm of propellant in 0.141 sec, it burns propellant at the rate of 15,400 gm/sec. Hence

$$\dot{m} = 15,400$$

So (A1.2) becomes

$$\rho A v = 15,400$$

and (A1.1) becomes

$$P = 3,040,000 T \rho$$

Then

$$\rho_c = 0.0142$$

and so

$$v_c = 11,900$$

(This seems large because it is in centimeters per second.) We recall that

$$C_P = \frac{\gamma n R}{\gamma - 1}$$

and so conclude that

$$C_P = 18,200,000$$

Then (A1.3) becomes

$$36,400,000 T + v^2 = 117,000,000,000 \quad (\text{A1.16})$$

By (A1.11), we get

$$T_i = 2,910^\circ K$$

By (A1.12),

$$v_i = 103,000 \text{ cm/sec} = 3,380 \text{ ft/sec}$$

By (A1.14)

$$C_D = 6.58 \times 10^{-6}$$

So (A1.15) reduces to

$$A = \frac{6.05 \times 10^{19}}{T^5 \sqrt{3,204 - T}}$$

Into this we put $A = A_s = 35.9$. Solving for T gives $T_s = 2,217$. Then by (A1.16)

$$v_s = 190,000 \text{ cm/sec} = 6,220 \text{ ft/sec}$$

By (A1.6)

$$P_s = 1.52 \times 10^7 \text{ dynes/cm}^2 = 221 \text{ lb/in.}^2$$

By (A1.13), the ultimate gas velocity is

$$342,000 \text{ cm/sec} = 11,200 \text{ ft/sec}$$

Let us compute v_x by (I.1.4). Taking

$$P_a = 14.7 \text{ lb/in.}^2 = 1,013,200 \text{ dynes/cm}^2$$

we get

$$v_x = 223,000 \text{ cm/sec} = 7,300 \text{ ft/sec}$$

APPENDIX 2

DERIVATION OF PRINCIPLE V

To derive Principle V, we make suitable extensions of the proof of Principle IV, as given in Secs. 32 and 33 of Reference 9. We shall follow the notation of this proof. We call attention to the reasoning in Sec. 32, which can be used to show that if Principle V can be proved for moments about the center of gravity itself, then the principle will follow for moments with respect to any axis that passes through the center of gravity and is fixed in direction. Accordingly, we shall prove Principle V for moments about the center of gravity, a procedure which has the advantage of avoiding various algebraic difficulties.

Let S be our system of particles. Consider a particular time τ at which we wish to establish Principle V. Define an auxiliary system \bar{S} as always consisting of exactly those particles which are in S at time τ . For the particles of S and \bar{S} , let m_j and \mathbf{r}_j be the masses and the position vectors relative to an origin fixed in space. Let Σ denote a summation over the particles of S , $\bar{\Sigma}$ a summation over the particles of \bar{S} , and Σ^A a summation over the particles of \bar{S} that are not in S . Let M and \bar{M} be the masses of S and \bar{S} , so that

$$M = \Sigma m_j \quad (\text{A2.1})$$

$$\bar{M} = \bar{\Sigma} m_j \quad (\text{A2.2})$$

Define \mathbf{G} and $\bar{\mathbf{G}}$ by

$$M\mathbf{G} = \Sigma m_j \mathbf{r}_j \quad (\text{A2.3})$$

$$\bar{M}\bar{\mathbf{G}} = \bar{\Sigma} m_j \mathbf{r}_j \quad (\text{A2.4})$$

Then \mathbf{G} and $\bar{\mathbf{G}}$ are the position vectors of the centers of gravity of S and \bar{S} . Finally define ϱ_j and $\bar{\varrho}_j$ by

$$\varrho_j = \mathbf{r}_j - \mathbf{G} \quad (\text{A2.5})$$

$$\bar{\varrho}_j = \mathbf{r}_j - \bar{\mathbf{G}} \quad (\text{A2.6})$$

Then ϱ_j and $\bar{\varrho}_j$ are the position vectors of the particles relative to the centers of gravity of S and \bar{S} . By (A2.5) and (A2.6),

$$\bar{\varrho}_j = \varrho_j + \mathbf{G} - \bar{\mathbf{G}} \quad (\text{A2.7})$$

Using a prime to denote a time derivative as in Reference 9, we get

$$\bar{\varrho}'_j = \varrho'_j + \mathbf{G}' - \bar{\mathbf{G}}' \quad (\text{A2.8})$$

If we multiply (A2.5) and (A2.6) by m_i and sum, we get

$$\begin{aligned}\Sigma m_i \varrho_i &= \Sigma m_i x_i - \Sigma m_i \mathbf{G} \\ \bar{\Sigma} m_i \bar{\varrho}_i &= \bar{\Sigma} m_i x_i - \bar{\Sigma} m_i \bar{\mathbf{G}}\end{aligned}$$

By (A2.1), (A2.2), (A2.3), and (A2.4), these reduce to

$$\Sigma m_i \varrho_i = 0 \quad (\text{A2.9})$$

$$\bar{\Sigma} m_i \bar{\varrho}_i = 0 \quad (\text{A2.10})$$

Differentiating (A2.10) with respect to time gives

$$\bar{\Sigma} m_i \bar{\varrho}'_i = 0 \quad (\text{A2.11})$$

It would be difficult to differentiate (A2.9) with respect to time, since the summation is over different sets of particles at different times.

By (A2.7),

$$\bar{\Sigma} m_i (\bar{\varrho}_i \times \bar{\varrho}'_i) = \bar{\Sigma} m_i (\varrho_i \times \varrho'_i) + (\mathbf{G} - \bar{\mathbf{G}}) \times (\bar{\Sigma} m_i \bar{\varrho}'_i)$$

By (A2.11), this reduces to

$$\bar{\Sigma} m_i (\bar{\varrho}_i \times \bar{\varrho}'_i) = \bar{\Sigma} m_i (\varrho_i \times \varrho'_i) \quad (\text{A2.12})$$

By (A2.8),

$$\Sigma m_i (\varrho_i \times \varrho'_i) = \Sigma m_i (\varrho_i \times \varrho'_i) + (\Sigma m_i \varrho_i) \times (\mathbf{G}' - \bar{\mathbf{G}}')$$

By (A2.9), this reduces to

$$\Sigma m_i (\varrho_i \times \varrho'_i) = \Sigma m_i (\varrho_i \times \varrho'_i) \quad (\text{A2.13})$$

We will need a limit theorem. For this and subsequent formulas, it will be necessary to write various of our terms as explicit functions of time. Thus

$$\begin{aligned}\varrho_i &= \varrho_i(t) \\ \varrho'_i &= \varrho'_i(t) \\ \mathbf{G}' &= \mathbf{G}'(t) \\ &\text{etc.}\end{aligned}$$

To within second-order terms in dt ,

$$\begin{aligned}\mathbf{G}(\tau) &\cong \mathbf{G}(\tau + dt) - dt \mathbf{G}'(\tau + dt) \\ \bar{\mathbf{G}}(\tau) &\cong \bar{\mathbf{G}}(\tau + dt) - dt \bar{\mathbf{G}}'(\tau + dt)\end{aligned}$$

However, $\mathbf{G}(\tau) = \bar{\mathbf{G}}(\tau)$, since S and \bar{S} coincide at time τ by definition of \bar{S} . So

$$dt(\bar{\mathbf{G}}'(\tau + dt) - \mathbf{G}'(\tau + dt)) \cong \bar{\mathbf{G}}(\tau + dt) - \mathbf{G}(\tau + dt) \quad (\text{A2.14})$$

By (A2.3) and (A2.4),

$$\bar{M}\bar{G} = \Sigma^{\Delta}m_jx_j + MG$$

So by (A2.1),

$$\bar{M}\bar{G} = \Sigma^{\Delta}m_jx_j + \Sigma m_jG = \Sigma^{\Delta}m_jx_j + (\bar{\Sigma}m_j - \Sigma^{\Delta}m_j)G$$

So by (A2.2),

$$\bar{M}(\bar{G} - G) = \Sigma^{\Delta}m_j(x_j - G)$$

Finally, we use (A2.5) and get

$$\bar{M}(\bar{G} - G) = \Sigma^{\Delta}m_j\varrho_j$$

We specialize to time $\tau + dt$, so that

$$\bar{M}[\bar{G}(\tau + dt) - G(\tau + dt)] = \Sigma^{\Delta}m_j\varrho_j(\tau + dt)$$

We note that, by (A2.14), both sides of this are differentials of at least the first order in dt . So if we take the cross product of this with (A2.14), which is correct to within second-order terms in dt , the resulting equation, namely,

$$\begin{aligned} [\Sigma^{\Delta}m_j\varrho_j(\tau + dt)] \times dt[\bar{G}'(\tau + dt) - G'(\tau + dt)] \\ \cong \bar{M}[\bar{G}(\tau + dt) - G(\tau + dt)] \times [\bar{G}(\tau + dt) - G(\tau + dt)] \end{aligned}$$

will be correct to within third-order terms in dt . However, the right side of this resulting equation is zero, being proportional to the cross product of a vector with itself. So the left side, namely,

$$[\Sigma^{\Delta}m_j\varrho_j(\tau + dt)] \times dt[\bar{G}'(\tau + dt) - G'(\tau + dt)]$$

is a differential of the third order in dt . Therefore,

$$\lim_{dt \rightarrow 0} \frac{[\Sigma^{\Delta}m_j\varrho_j(\tau + dt)] \times [\bar{G}'(\tau + dt) - G'(\tau + dt)]}{dt} = 0 \quad (\text{A2.15})$$

We have now established the necessary preliminary relations and can proceed to the actual proof. From Eq. (33.5) of Reference 9, applied to the system \bar{S} at time τ , we get

$$\bar{\Sigma}m_j[\bar{\varrho}_j(\tau) \times \bar{\varrho}'_j(\tau)]' = \bar{\Sigma}[\bar{\varrho}_j(\tau) \times F'_j{}^{\varrho}]$$

We write this in the differential form

$$\begin{aligned} \bar{\Sigma}m_j[\bar{\varrho}_j(\tau + dt) \times \bar{\varrho}'_j(\tau + dt)] - \bar{\Sigma}m_j[\bar{\varrho}_j(\tau) \times \bar{\varrho}'_j(\tau)] \\ = dt\bar{\Sigma}[\bar{\varrho}_j(\tau) \times F_j{}^{\varrho}] \quad (\text{A2.16}) \end{aligned}$$

However, since S and \bar{S} coincide at time τ ,

$$\bar{\varrho}_j(\tau) = \varrho_j(\tau)$$

Also, Σ and $\bar{\Sigma}$ denote the same summation at time τ . Thus (A2.16) reduces to

$$\bar{\Sigma} m_j [\mathfrak{p}_j(\tau + dt) \times \mathfrak{p}'_j(\tau + dt)] - \Sigma m_j [\mathfrak{p}_j(\tau) \times \mathfrak{p}'_j(\tau)] = dt \Sigma [\mathfrak{p}_j(\tau) \times \mathbf{F}_j^{(e)}]$$

Applying (A2.12) in this gives

$$\bar{\Sigma} m_j [\mathfrak{p}_j(\tau + dt) \times \mathfrak{p}'_j(\tau + dt)] - \Sigma m_j [\mathfrak{p}_j(\tau) \times \mathfrak{p}'_j(\tau)] = dt \Sigma [\mathfrak{p}_j(\tau) \times \mathbf{F}_j^{(e)}]$$

Since

$$\bar{\Sigma} = \Sigma^A + \Sigma$$

the last equation gives

$$\Sigma m_j [\mathfrak{p}_j(\tau + dt) \times \mathfrak{p}'_j(\tau + dt)] - \Sigma m_j [\mathfrak{p}_j(\tau) \times \mathfrak{p}'_j(\tau)] + \Sigma^A m_j [\mathfrak{p}_j(\tau + dt) \times \mathfrak{p}'_j(\tau + dt)] = dt \Sigma [\mathfrak{p}_j(\tau) \times \mathbf{F}_j^{(e)}]$$

By use of (A2.13), this reduces to

$$\Sigma m_j [\mathfrak{p}_j(\tau + dt) \times \mathfrak{p}'_j(\tau + dt)] - \Sigma m_j [\mathfrak{p}_j(\tau) \times \mathfrak{p}'_j(\tau)] + \Sigma^A m_j [\mathfrak{p}_j(\tau + dt) \times \mathfrak{p}'_j(\tau + dt)] = dt \Sigma [\mathfrak{p}_j(\tau) \times \mathbf{F}_j^{(e)}]$$

Finally, we use (A2.8) to get

$$\begin{aligned} & \Sigma m_j [\mathfrak{p}_j(\tau + dt) \times \mathfrak{p}'_j(\tau + dt)] - \Sigma m_j [\mathfrak{p}_j(\tau) \times \mathfrak{p}'_j(\tau)] \\ & + \Sigma^A m_j [\mathfrak{p}_j(\tau + dt) \times \mathfrak{p}'_j(\tau + dt)] \\ & - [\Sigma^A m_j \mathfrak{p}_j(\tau + dt)] \times [\mathbf{G}'(\tau + dt) - \mathbf{G}'(\tau + dt)] \\ & = dt \Sigma [\mathfrak{p}_j(\tau) \times \mathbf{F}_j^{(e)}] \end{aligned}$$

Now we divide both sides by dt and let dt go to zero. The quotient of the first two terms divided by dt approaches the time rate of change of the moment of momentum of S , taken with respect to the center of gravity of S . The quotient of the third term divided by dt approaches the rate at which moment of momentum, taken with respect to the center of gravity of S , is being transferred out of S by the particles that are leaving S . Finally, the quotient of the fourth term divided by dt approaches zero, by (A2.15).

Thus we have proved Principle V for moments about the center of gravity of S at time τ . However, since we have not introduced any restrictions on the time τ , Principle V holds in general.

APPENDIX 3

MINOR FACTORS AFFECTING THE FLIGHT OF A ROCKET

It may appear to the reader that we have been exhaustive in our treatment of the factors that affect the flight of a rocket. In one sense, we have. In Chap. I we took account of all factors that have appeared significant for rockets in present use. At the same time, we ignored various minor factors. Because it has been possible to ignore these minor factors in the past, no careful analysis of them has been made, and none is intended here. However, a rough analysis is needed to verify that these factors are really minor. It seems worth while to put this analysis on record because a similar rough analysis would be needed for any new type of rocket.

We have specified the rocket as consisting of the metal parts, the unburnt fuel, and the gas inside the geometric surface of Fig. I.1.1. We have used M to denote the mass of the rocket and v to denote the velocity of the center of gravity. We have then proceeded to use Mv as the momentum of our rocket. This accords with the general principle that the momentum of any system is the product of its mass and the velocity of its center of gravity. As it happens, this general principle is valid only for systems that always consist of the same particles and hence cannot be applied to a rocket.

The fact that many familiar principles are inapplicable to the study of rocket flight is liable to trip the unwary. Actually, in this case, the familiar principle is approximately applicable, as we now proceed to show.

We proceed to determine the momentum of our rocket as the sum of the momenta of its separate parts. Let w be the velocity of the metal framework of the rocket. In general, w will not equal v , since the center of gravity of the rocket shifts relative to the metal framework because of the consumption of fuel. Now for any element of volume of our rocket, let u be the rearward velocity of the matter in that element relative to the metal framework and let dM be the mass of matter in that element. If our rocket is functioning at a steady rate, then u and dM will be subject to little variation. For instance, if we consider an element of volume in the nozzle, the matter in that element will consist of rapidly moving gas, so that it is quickly replaced

by more gas. Nevertheless, the new gas will be moving as fast as the original gas and will have the same pressure, density, etc. Thus, despite the rapid passage of gas through our element of volume, the u and dM for the gas in our element are constant.

An important exception to the constancy of u and dM will be at the surface of the rocket fuel. Because of the consumption of fuel, this surface is receding, so that an element of volume near the surface will contain solid or liquid fuel one moment and some sort of gas the next moment. If one is using liquid fuel with a pressure feeding system, then as the pressure in the pressure tank diminishes, dM will decrease for elements of volume inside the pressure tank and we will have another case of inconstant u or dM . One can conceive of other sources of variation of u and dM . If our fuel system involves pumps with reciprocating parts, one will have violent changes of u and dM ; this will likewise be true if aerodynamic forces cause a flutter of some of the metal parts.

In the main, these variations of u and dM are of little effect. To show how one might treat them if it should be necessary and to indicate of how little effect they are, we shall as an illustration take account of the receding of the surface of the fuel in the present treatment.

For any element of volume, the actual velocity of the included matter is $w - u$, and so the actual momentum is $(w - u) dM$. So the total momentum of the rocket is

$$\int (w - u) dM = Mw - \int u dM$$

From this, one gets the time rate of change of momentum to be

$$M\dot{w} - \dot{m}w - \frac{d}{dt} \int u dM$$

(The reader will recall that $dM/dt = -\dot{m}$.) As we are assuming that u and dM are constant except at the receding fuel surface, we can compute $(d/dt) \int u dM$ by merely finding relative to the metal framework the time rate of change of momentum associated with the receding of the fuel surface. For this, let us take as an element of volume the volume from which fuel is removed by the receding of the fuel surface in time dt . The mass of fuel in this volume before receding is just the mass of fuel consumed in time dt , namely, $\dot{m} dt$. Thus the momentum before receding is $u \dot{m} dt$, where u is the rearward velocity of the fuel near the surface relative to the metal framework. After receding, the momentum in this volume is effectively zero, since the fuel has been replaced by a gas of relatively much lower density. So

$$\frac{d}{dt} \int u dM = -u\dot{m}$$

We conclude finally that the time rate of change of the momentum of a rocket is equal to

$$M\dot{w} - \dot{m}w + \dot{m}u \quad (\text{A3.1})$$

For a solid fuel, which is constrained to move with the metal framework, $u = 0$ and the time rate of change of momentum is just

$$M\dot{w} - \dot{m}w = \frac{d}{dt} (Mw)$$

For a liquid fuel, u is the rate at which the surface of the liquid is receding rearward because of the consumption of the fuel. If one has a double-fuel rocket, one must replace the term $\dot{m}u$ by the sum of two terms, one for each fuel, the term for either fuel being the product of the time rate of consumption of that fuel and the rate of recession rearward of its surface.

In (I.1.2), the dominating term is $\dot{m}v_e$. By comparison, the term $\dot{m}u$ which occurs in (A3.1) is of little consequence for the usual type of rocket, since v_e is of the order of several thousand feet per second, whereas u can hardly run over a few feet per second. Certainly, present experimental methods do not permit the measurement of v_e with an accuracy that would justify taking account of u in comparison with v_e . In fact, the variation in v_e due to nonuniformity of the rocket process is probably greater than u . So we ignore the $\dot{m}u$ term in (A3.1) and say simply that the time rate of change of the momentum of a rocket is equal to

$$M\dot{w} - \dot{m}w = \frac{d}{dt} (Mw)$$

Let us try to express this in terms of the velocity v of the rocket. We have

$$M\dot{w} - \dot{m}w = M\dot{v} - \dot{m}w + M \frac{d}{dt} (w - v)$$

Now $w - v$ is just the rearward velocity of the center of gravity of the rocket relative to the metal framework of the rocket. We wish an estimate for $M(d/dt)(w - v)$.

With most types of rocket construction, the coordinate of the center of gravity of the rocket relative to the metal framework is essentially a linear function of the amount of unburnt fuel. For a rocket for which the fuel weighs more than all the rest of the rocket, the deviation from linearity could be noticeable but not very much so,

and in one such rocket (the German V-2) the fuel tanks were so designed that the center of gravity remained fixed as the fuel burned. Hence $w - v$ is essentially a linear function of the rate \dot{m} at which fuel is being consumed. In the current models of rockets, the fuel is burned at a nearly constant rate, so that \dot{m} is nearly constant. Hence $w - v$ is nearly constant, and $d(w - v)/dt$ is nearly zero, and so we usually can neglect $d(w - v)/dt$ in comparison with \dot{v} , since \dot{v} is usually large. In certain rocket applications that we know of, \dot{v} is very small, but even in these cases $M(d/dt)(w - v)$ is insignificant in comparison with other terms of (I.1.2), notably $\dot{m}v_s$. Therefore, we shall ignore the term $M(d/dt)(w - v)$. Thus we say that the time rate of change of the momentum of a rocket is $M\dot{v} - \dot{m}w$. One could write this as $M\dot{v} - \dot{m}w - \dot{m}(w - v)$ and justify neglecting the term $\dot{m}(w - v)$, but it is more satisfactory not to do so.

Now we consider the rate at which momentum is crossing the exit of the nozzle. We said earlier (and ambiguously) that v_s is the velocity of the gas relative to the rocket. Specifically, v_s is the velocity relative to the nozzle. For all present rockets, the nozzle is fixed relative to the metal framework of the rocket, so that v_s is the velocity of the gas relative to the metal framework of the rocket. So the gas crossing the exit surface has a velocity of $w - v_s$.

We earlier ignored the fact that v_s is not constant over the exit surface but can vary in both direction and magnitude. For an accurate derivation, $w - v_s$ must be taken as a vector difference. Therefore, if μ is the mass of gas per unit area crossing the exit surface per unit time, then the total rate at which momentum is being transported across the exit surface by the departing gas is $\int \overrightarrow{(w - v_s)} \mu dA$, the integral being taken over the exit surface and the arrow indicating a vector. This is equal to $\overrightarrow{\dot{m}w} - \int \overrightarrow{v_s} \mu dA$. So, by Principle II,

$$\overrightarrow{\Sigma F^e(t)} = M\overrightarrow{\dot{v}} - \overrightarrow{\dot{m}w} + \overrightarrow{\dot{m}w} - \int \overrightarrow{v_s} \mu dA$$

Hence

$$M\overrightarrow{\dot{v}} = \int \overrightarrow{v_s} \mu dA + \overrightarrow{\Sigma F^e(t)} \quad (\text{A3.2})$$

The term $\overrightarrow{\Sigma F^e(t)}$ will involve a second integral, namely, $\int P_s \overrightarrow{dA}$. To evaluate these integrals of velocity and pressure over the exit of the nozzle requires a more elaborate study of flow through a nozzle than that given in Appendix 1. The result of evaluating the integrals will be to supply theoretical values of T , L , δ_r , and γ (see Fig. I.5.1). This would be a pleasant accomplishment, but for any particular rocket it is not necessary, since one can make an experimental determination of T , L , δ_r , and γ by firing in a test stand. In other words,

if we take components in (A3.2), we will get (I.5.6) and (I.5.7), except for one small term which was ignored in the derivations of (I.5.6) and (I.5.7). We now consider this term.

Since this term is small, we shall make only an approximate derivation of it; in particular, we shall assume $\delta_r = 0$.

Because of the yawing motion of the rocket, the gas proceeding out of the nozzle has a sidewise velocity of $r_t\phi$ (see the discussion of jet damping). Accordingly there is a sidewise transfer of momentum at a rate $\dot{m}r_t\phi$. This has components

$$\dot{m}r_t\phi \sin \delta \quad (\text{A3.3})$$

in the direction of motion and

$$-\dot{m}r_t\phi \cos \delta \quad (\text{A3.4})$$

perpendicular to the direction of motion. Hence these terms should be added to the left sides of (I.5.6) and (I.5.7), respectively.

After burning, \dot{m} will be zero, so we only have to consider (A3.3) and (A3.4) during burning. With (A3.4) inserted on the left side, we can write (I.5.7V) in the form

$$\begin{aligned} (Mv - \dot{m}r_t \cos \delta)\dot{\theta} &= T \sin (\delta - \delta_r) \\ &+ \dot{m}r_t \cos \delta v \frac{d\delta}{ds} - Mg \cos \theta \\ &+ K_L \rho d^2 v^2 \sin (\delta - \delta_L) + K_{sp} d^2 v \phi \cos \delta - F_2 \end{aligned}$$

Typical approximate values for the M8 rocket are

$$\begin{aligned} M &= 35 \text{ lb} \\ \dot{m} &= 34 \text{ lb/sec} \\ r_t &= 1 \text{ ft} \\ T &= 240,000 \text{ poundals} \\ v &\leq 1,500 \text{ ft/sec} \\ \sigma &= 200 \text{ ft} \end{aligned}$$

As v will usually be considerably greater than 100 when the rocket is released from the constraint of the launcher, one can omit $\dot{m}r_t \cos \delta$ from the coefficient of $\dot{\theta}$.

We neglect

$$\dot{m}r_t \cos \delta v \frac{d\delta}{ds} \quad (\text{A3.5})$$

by comparison with

$$T \sin (\delta - \delta_r) \quad (\text{A3.6})$$

Here the situation is not so clear cut, because for certain values of δ , notably $\delta = \delta_r$, we will actually have (A3.6) smaller than (A3.5). However, if

$$\delta \cong A \sin \left(\frac{2\pi s}{\sigma} - B \right)$$

then the average absolute value of $\sin(\delta - \delta_r)$ is of the order of

$$\frac{2A}{\pi} = 0.6A$$

whereas the average absolute value of $d\delta/ds$ is of the order of

$$\frac{4A}{\sigma} = 0.02A$$

Also $T = 240,000$, whereas

$$\dot{m}r \cos \delta v \leq 50,000$$

Therefore, the average absolute value of (A3.5) is less than 1 per cent of the average absolute value of (A3.6). This seems sufficient justification for neglecting (A3.5).

To justify neglecting (A3.3) in (I.5.6), we note that since

$$K_{sp} d^3 = 0.08$$

the term

$$K_{sp} d^3 v \phi \sin \delta \tag{A3.7}$$

will be as great as (A3.3) for $v \geq 400$. However, launching velocities are seldom much under 400, so that we may take (A3.3) as being of the same order as (A3.7). However, when we simplified (I.5.10) to (I.5.14), we justified neglecting (A3.7), and so we can conclude that it is proper to neglect (A3.3) also.

There are structural effects that are usually ignored. One is the change in shape of the rocket due to heat and pressure in the rocket chamber when the propellant fuel begins to burn. Certain investigators have claimed that such changes of shape are appreciable, but most people consider them negligible. In all honesty, it must be said that little careful study has been made of the matter. The same is true of a second effect, namely, the flexibility of the rocket under lateral stresses. When a rocket yaws, there are sidewise aerodynamic forces on the fins tending to push them back into the line of flight. These forces must cause some bending of the rocket. If such bending is appreciable, then it will throw the axis of the thrust off the center of gravity of the rocket. Thus there will result a transient value of L (see Fig. I.5.1) tending to preserve the existing yaw. With a sufficiently flexible rocket, this could result in a serious loss of stability. Such a loss would be apparent in an increase of σ during burning. The evidence on this point is rather inconclusive, but for current rockets it seems to be the case that there is no appreciable increase of σ during burning. Accordingly, we appear justified in neglecting flexing of the rocket body during flight.

APPENDIX 4

FUNCTIONS FOR USE WITH AN UNSTABLE ROCKET

To abridge the formulas of this appendix, we introduce the temporary notations

$$F(w) = e^{-w^2} \int_0^w e^{y^2} dy \quad (\text{A4.1})$$

$$\phi(w) = e^{w^2} \int_w^\infty e^{-y^2} dy \quad (\text{A4.2})$$

$$IF(w) = \int_0^w F(x) dx = \int_0^w e^{-x^2} \int_0^x e^{y^2} dy dx \quad (\text{A4.3})$$

$$I\phi(w) = \int_0^w \phi(x) dx = \int_0^w e^{x^2} \int_x^\infty e^{-y^2} dy dx \quad (\text{A4.4})$$

The functions $I_1(u)$, $I_2(u)$, and $id(u)$ needed for Sec. 14 of Chap. III are given by

$$I_1(u) = 2e^{uF(\sqrt{u})} \quad (\text{A4.5})$$

$$I_2(u) = 2e^{-u\phi(\sqrt{u})} \quad (\text{A4.6})$$

$$id(u) = 4[IF(\sqrt{u}) + I\phi(\sqrt{u})] \quad (\text{A4.7})$$

In Table 3 are given values of $F(w)$, $IF(w)$, and $I\phi(w)$. Values of $\phi(w)$ can be obtained readily by use of the relation

$$\phi(w) = \frac{1 - \operatorname{erf}(w)}{(2/\sqrt{\pi})e^{-w^2}} \quad (\text{A4.8})$$

since both

$$\operatorname{erf}(w) = \frac{2}{\sqrt{\pi}} \int_0^w e^{-y^2} dy$$

and

$$\frac{2}{\sqrt{\pi}} e^{-w^2}$$

are very fully tabulated in Reference 15. In any case, $\operatorname{erf}(w)$ or one of the related functions

$$\operatorname{erf}\left(\frac{w}{\sqrt{2}}\right) = \frac{1}{\sqrt{2\pi}} \int_{-w}^w e^{-y^2/2} dy$$

$$\frac{1}{2} \operatorname{erf}\left(\frac{w}{\sqrt{2}}\right) = \frac{1}{\sqrt{2\pi}} \int_0^w e^{-y^2/2} dy$$

can be found tabulated in so many of the available sets of tables that it seemed superfluous for us to tabulate $\phi(w)$. Especially is this so

since the relation for $I_2(u)$ in terms of $erf(w)$,

$$I_2(u) = \sqrt{\pi} [1 - erf(\sqrt{u})] \tag{A4.9}$$

is easier to use than the relation (A4.6) for $I_2(u)$ in terms of $\phi(w)$.

More accurate values of $F(w)$, $\phi(w)$, $IF(w)$, $I\phi(w)$ are given in Reference 13, whose Table 2 contains 10-decimal values of the four functions.

Section 26 of Reference 13 is devoted to a discussion of the means of computing the four functions. From it we quote the following results which are suitable for use when $6 \leq w$:

$$F(w) \cong \frac{1}{2w} + \frac{1}{4w^3} + \frac{1 \cdot 3}{8w^5} + \frac{1 \cdot 3 \cdot 5}{16w^7} + \dots + \frac{(2N - 2)!}{(N - 1)!(2w)^{2N-1}} \tag{A4.10}$$

with error less than

$$\phi(w) \cong \frac{1}{2w} - \frac{1}{4w^3} + \frac{1 \cdot 3}{8w^5} - \frac{1 \cdot 3 \cdot 5}{16w^7} + \dots + \frac{(-1)^{N-1}(2N - 2)!}{(N - 1)!(2w)^{2N-1}} \tag{A4.11}$$

with error less than

$$IF(w) \cong \frac{1}{2} \ln w + \frac{1}{4} (\gamma + \ln 4) - \frac{1}{4(2w^2)} - \frac{1 \cdot 3}{8(2w^2)^2} - \frac{1 \cdot 3 \cdot 5}{12(2w^2)^3} - \dots - \frac{(2N)!}{N!2^N(4N)(2w^2)^N} \tag{A4.12}$$

with error less than

$$I\phi(w) \cong \frac{1}{2} \ln w + \frac{1}{4} (\gamma + \ln 4) + \frac{1}{4(2w^2)} - \frac{1 \cdot 3}{8(2w^2)^2} + \frac{1 \cdot 3 \cdot 5}{12(2w^2)^3} - \dots + \frac{(-1)^{N+1}(2N)!}{N!2^N(4N)(2w^2)^N} \tag{A4.13}$$

with error less than

$$\frac{(2N + 2)!}{(N + 1)!2^{N+1}(4N + 4)(2w^2)^{N+1}}$$

We record the approximate value

$$\frac{1}{4}(\gamma + \ln 4) = 0.4908775065 \dots$$

If one is interested in $id(u)$ rather than $IF(w)$ or $I\phi(w)$, one can substitute (A4.12) and (A4.13) into (A4.7) with a resulting formula for $id(u)$ that is simpler than either (A4.12) or (A4.13).

We note the relation

$$I\phi(w) = IF(w) + F(w)\phi(w) \quad (\text{A4.14})$$

from which one can get the convenient check formula

$$I_1(u)I_2(u) + id(u) = 8I\phi(\sqrt{u}) \quad (\text{A4.15})$$

For use in computing accurate values near zero, we record the following relations:

$$F(w) = w - \frac{2w^3}{1 \cdot 3} + \frac{4w^5}{1 \cdot 3 \cdot 5} - \frac{8w^7}{1 \cdot 3 \cdot 5 \cdot 7} + \frac{16w^9}{1 \cdot 3 \cdot 5 \cdot 7 \cdot 9} - \dots \quad (\text{A4.16})$$

$$\phi(w) = \frac{\sqrt{\pi}}{2} e^{w^2} - w - \frac{2w^3}{1 \cdot 3} - \frac{4w^5}{1 \cdot 3 \cdot 5} - \frac{8w^7}{1 \cdot 3 \cdot 5 \cdot 7} - \frac{16w^9}{1 \cdot 3 \cdot 5 \cdot 7 \cdot 9} - \dots \quad (\text{A4.17})$$

$$IF(w) = \frac{w^2}{2} - \frac{2w^4}{4 \cdot 1 \cdot 3} + \frac{4w^6}{6 \cdot 1 \cdot 3 \cdot 5} - \frac{8w^8}{8 \cdot 1 \cdot 3 \cdot 5 \cdot 7} + \frac{16w^{10}}{10 \cdot 1 \cdot 3 \cdot 5 \cdot 7 \cdot 9} - \dots \quad (\text{A4.18})$$

$$I\phi(w) = \frac{\sqrt{\pi}}{2} e^{w^2} F(w) - \frac{w^2}{2} - \frac{2w^4}{4 \cdot 1 \cdot 3} - \frac{4w^6}{6 \cdot 1 \cdot 3 \cdot 5} - \frac{8w^8}{8 \cdot 1 \cdot 3 \cdot 5 \cdot 7} - \dots \quad (\text{A4.19})$$

$$F(-w) = -F(w) \quad (\text{A4.20})$$

$$\phi(-w) = \sqrt{\pi} e^{w^2} - \phi(w) \quad (\text{A4.21})$$

$$IF(-w) = IF(w) \quad (\text{A4.22})$$

$$I\phi(-w) = I\phi(w) - \sqrt{\pi} e^{w^2} F(w) \quad (\text{A4.23})$$

Substitution of (A4.18) and (A4.19) into (A4.7) gives a very simple series for $id(u)$.

The values in Table 3 were rounded off from the 10-decimal values given in Reference 13 and hence are in error by at most half a unit in the fifth decimal place.

Linear interpolation in Table 3 will give values that are accurate to within 0.0006 or better. For greater accuracy of interpolation, one can use the Lagrangian Interpolation Coefficients given in Reference 16. To indicate the accuracy of interpolation attainable, we have

constructed Fig. A4.1. A given method of interpolation gives different degrees of accuracy in different parts of the table. Accordingly, in Fig. A4.1, the value of w given along the lower edge of the figure is to be the value of w at which one is interpolating into Table 3. One chooses the curve appropriate to the function for which one is interpolating and to the method of interpolation. Then one can read off

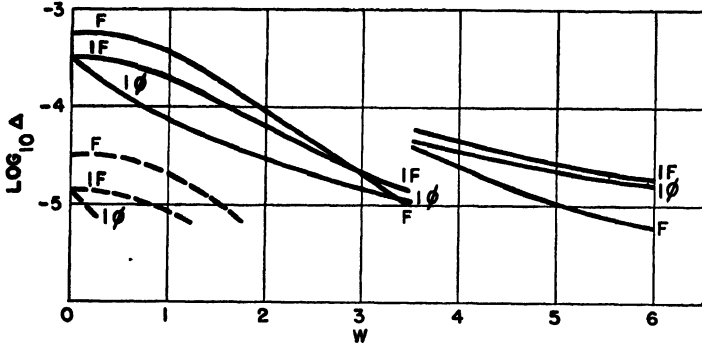

FIG. A4.1.—Interpolation error for Table 3. Solid curves refer to linear interpolation. Dashed curves refer to three-point interpolation.

a corresponding value of $\log_{10} \Delta$. The corresponding value of Δ , which can be obtained by taking the antilogarithm, is an upper bound for the error committed by using the chosen method of interpolation for the chosen function at the chosen value of w .

The breaks in the graphs for linear interpolation come at the point where the argument interval in Table 3 changes.

A four-point interpolation will give values that are correct to within one unit in the fifth decimal place. In fact the error in the method of interpolation is less than the error caused by the fact that the tabular values that are used in the interpolation have been rounded off to 5 decimal places.

TABLE 3.—FUNCTIONS FOR USE WITH AN UNSTABLE ROCKET

w	$F(w)$	$IF(w)$	$I\phi(w)$	w	$F(w)$	$IF(w)$	$I\phi(w)$	w	$F(w)$	$IF(w)$	$I\phi(w)$
0.0	0.00000	0.00000	0.00000	1.60	0.39994	0.65995+	0.76540	3.20	0.16546	1.05914	1.08398
0.05	0.04992	0.00125-	0.04310	1.65	0.38609	0.67660	0.77879	3.25	0.16257	1.06734	1.09131
0.10	0.09934	0.00498	0.08390	1.70	0.37256	0.69557	0.79187	3.30	0.15979	1.07540	1.09863
0.15	0.14777	0.01117	0.12260	1.75	0.35944	0.71387	0.80464	3.35	0.15711	1.08332	1.10584
0.20	0.19475+	0.01974	0.15937	1.80	0.34677	0.73152	0.81713	3.40	0.15452	1.09111	1.11296
0.25	0.23984	0.03061	0.19435-	1.85	0.33461	0.74855+	0.82933	3.45	0.15203	1.09878	1.11998
0.30	0.28263	0.04368	0.22768	1.90	0.32297	0.76499	0.84127	3.50	0.14962	1.10632	1.12691
0.35	0.32277	0.05893	0.25949	1.95	0.31188	0.78086	0.85296				
0.40	0.35994	0.07591	0.29898	2.00	0.30134	0.79619	0.86439	3.6	0.14504	1.12105-	1.14049
0.45	0.39390	0.09477	0.31897	2.05	0.29134	0.81100	0.87559	3.7	0.14075+	1.13273	1.15373
0.50	0.42444	0.11524	0.34683	2.10	0.28188	0.82533	0.88656	3.8	0.13672	1.14321	1.16663
0.55	0.45142	0.13715+	0.37356	2.15	0.27295-	0.83920	0.89732	3.9	0.13293	1.15269	1.17922
0.60	0.47476	0.16032	0.39923	2.20	0.26451	0.85263	0.90786	4.0	0.12935-	1.17580	1.19150+
0.65	0.49445-	0.18457	0.42390	2.25	0.25655+	0.86566	0.91820	4.1	0.12596	1.18856	1.20350+
0.70	0.51050+	0.20871	0.44765+	2.30	0.24905+	0.87830	0.92834	4.2	0.12276	1.20100	1.21523
0.75	0.52301	0.23556	0.47053	2.35	0.24198	0.89057	0.93830	4.3	0.11972	1.21312	1.22669
0.80	0.53210	0.26195+	0.49259	2.40	0.23531	0.90250+	0.94807	4.4	0.11684	1.22495-	1.23791
0.85	0.53794	0.28872	0.51389	2.45	0.22902	0.91411	0.95766	4.5	0.11400	1.23649	1.24898
0.90	0.54072	0.31569	0.53447	2.50	0.22308	0.92541	0.96709	4.6	0.11147	1.24777	1.25982
0.95	0.54069	0.34274	0.55486	2.55	0.21747	0.93642	0.97635-	4.7	0.10888	1.25879	1.27014
1.00	0.53908	0.36972	0.57362	2.60	0.21217	0.94716	0.98545-	4.8	0.10659	1.26957	1.28045-
1.05	0.53316	0.39651	0.59227	2.65	0.20714	0.95764	0.99439	4.9	0.10431	1.28011	1.29055-
1.10	0.52621	0.42300	0.61095-	2.70	0.20237	0.96788	1.00319	5.0	0.10213	1.29044	1.30046
1.15	0.51749	0.44910	0.62788	2.75	0.19785+	0.97788	1.01184	5.1	0.10004	1.30054	1.31017
1.20	0.50727	0.47473	0.64490	2.80	0.19355+	0.98767	1.02035+	5.2	0.09804	1.31045-	1.31971
1.25	0.49583	0.49981	0.66144	2.85	0.18946	0.99724	1.02873	5.3	0.09612	1.32001+	1.32907
1.30	0.48340	0.52429	0.67751	2.90	0.18558	1.00662	1.03697	5.4	0.09427	1.32967	1.33826
1.35	0.47022	0.54814	0.69314	2.95	0.18183	1.01580	1.04509	5.5	0.09249	1.33901	1.34729
1.40	0.45651	0.57131	0.70895+	3.00	0.17827	1.02480	1.05308	5.6	0.09078	1.34817	1.35616
1.45	0.44246	0.59378	0.72317	3.05	0.17486	1.03363	1.06096	5.7	0.08914	1.35717	1.36487
1.50	0.42825-	0.61555-	0.73760	3.10	0.17160	1.04229	1.06871	5.8	0.08755+	1.36600	1.37344
1.55	0.41403	0.63661	0.75167	3.15	0.16847	1.05079	1.07635+	5.9	0.08602	1.37468	1.38187
								6.0	0.08454	1.38321	1.39016

APPENDIX 5

FUNCTIONS FOR USE WITH JET DAMPING

We temporarily denote

$$2 \int_0^w rc(y^2)e^{iy^2} dy$$

by $F_c(w)$, and its real and imaginary parts by $F_r(w)$ and $F_i(w)$. Accordingly, we have

$$F_c(w) = F_r(w) + jF_i(w) = 2 \int_0^w rc(y^2)e^{iy^2} dy \quad (\text{A5.1})$$

$$F_r(w) = 2 \int_0^w [rr(y^2) \cos y^2 - rj(y^2) \sin y^2] dy$$

$$F_i(w) = 2 \int_0^w [rr(y^2) \sin y^2 + rj(y^2) \cos y^2] dy$$

The integral in Sec. 9 of Chap. III for which values are needed is

$$\int_0^u \frac{rc(x)e^{ix} dx}{\sqrt{x}} = F_c(\sqrt{u}) \quad (\text{A5.2})$$

To supply the means of computing this integral, we have tabulated $F_r(w)$ and $F_i(w)$ in Table 4. This table was computed by a numerical integration, using Simpson's rule. It is believed that the tabular values are correct to within 0.0002, but this is not guaranteed. The error resulting from linear interpolation in the table is at most 0.005.

For $w > 4$, one can compute values by means of an asymptotic series, (A5.12), which we now derive. By (V.7.6) the error made in

$$\frac{rc(x)}{\sqrt{x}} \approx \sum_{k=0}^n j^k \frac{(2k)!}{k! 4^k x^{k+1}}$$

is not greater than the absolute value of the first term neglected,

$$\frac{(2n+2)!}{(n+1)! 4^{n+1} x^{n+2}}$$

and so the error in

$$\int_u^\infty \frac{e^{ix} rc(x)}{\sqrt{x}} dx \approx \int_u^\infty e^{ix} \sum_{k=0}^n j^k \frac{(2k)!}{k! 4^k x^{k+1}} dx \quad (\text{A5.3})$$

does not exceed

$$\int_u^\infty \frac{(2n + 2)!}{(n + 1)!4^{n+1}x^{n+2}} dx = \frac{(2n + 2)!}{(n + 1)!4^{n+1}(n + 1)u^{n+1}} \quad (A5.4)$$

We define

$$C_m = m!2^m \sum_{k=0}^m \frac{(-1)^k(2k)!}{(k!)^24^k} \quad (A5.5)$$

wherefore

$$C_0 = 1 \quad (A5.6)$$

$$C_m = 2mC_{m-1} + (-1)^m \frac{(2m)!}{m!2^m} \quad (A5.7)$$

Integration by parts gives

$$\int_u^\infty \frac{e^{jx}}{x^m} dx = j \frac{e^{ju}}{u^m} - jm \int_u^\infty \frac{e^{jx}}{x^{m+1}} dx \quad (A5.8)$$

Using this, we undertake to prove by induction on n that

$$\begin{aligned} \int_u^\infty e^{jx} \sum_{k=0}^n \frac{j^k(2k)!}{k!4^k x^{k+1}} dx &= -e^{ju} \sum_{m=0}^n \frac{(-j)^{m+1}C_m}{2^m u^{m+1}} \\ &+ \frac{(n + 1)(-j)^{n+1}C_n}{2^n} \int_u^\infty \frac{e^{jx}}{x^{n+2}} dx \quad (A5.9) \end{aligned}$$

If we put $m = 1$ in (A5.8) we verify (A5.9) for $n = 0$. Putting $m = n + 2$ in (A5.8) gives

$$\begin{aligned} \left[\frac{j^{n+1}(2n + 2)!}{(n + 1)!4^{n+1}} + \frac{(n + 1)(-j)^{n+1}C_n}{2^n} \right] \int_u^\infty \frac{e^{jx}}{x^{n+2}} dx \\ = - \frac{(-j)^{n+2}C_{n+1}}{2^{n+1}} \left[\frac{e^{ju}}{u^{n+2}} - (n + 2) \int_u^\infty \frac{e^{jx}}{x^{n+3}} dx \right] \end{aligned}$$

If we add this to (A5.9), we will deduce (A5.9) for $n + 1$. Thus, we can demonstrate (A5.9).

Note that the last term of (A5.9) is bounded in absolute value by

$$\frac{(n + 1)C_n}{2^n} \int_u^\infty \frac{dx}{x^{n+2}} = \frac{C_n}{2^n u^{n+1}}$$

By (A5.2), we have

$$F_0(\sqrt{u}) = \int_0^\infty \frac{rc(x)e^{jx}}{\sqrt{x}} dx - \int_u^\infty \frac{rc(x)e^{jx}}{\sqrt{x}} dx \quad (A5.10)$$

Accordingly, by using (A5.9), we can get an asymptotic series for

$F_e(\sqrt{u})$ as soon as we have evaluated

$$\int_0^{\infty} \frac{rc(x)e^{ix}}{\sqrt{x}} dx$$

In order to evaluate this, we make use of (V.4.7) and change the order of integration

$$\begin{aligned} \int_0^{\infty} e^{ix} \frac{rc(x)}{\sqrt{x}} dx &= \int_0^{\infty} e^{ix} \int_0^{\infty} \frac{e^{-xy}}{\sqrt{1-jy}} dy dx \\ &= \int_0^{\infty} \frac{1}{\sqrt{1-jy}} \int_0^{\infty} e^{(i-y)x} dx dy \\ &= \int_0^{\infty} \frac{1}{\sqrt{1-jy}(y-j)} dy \\ &= \frac{1}{\sqrt{2}} \left[\ln \frac{\sqrt{2}/(1-jy) - 1}{\sqrt{2}/(1-jy) + 1} \right]_0^{\infty} \\ &= \frac{1}{\sqrt{2}} \left[\pi j - \ln \frac{\sqrt{2}-1}{\sqrt{2}+1} \right] \end{aligned}$$

So we have finally

$$\int_0^{\infty} \frac{rc(x)e^{ix}}{\sqrt{x}} dx = \frac{\ln(3+2\sqrt{2})}{\sqrt{2}} + \frac{\pi}{\sqrt{2}} j \quad (\text{A5.11})$$

Collecting results and putting $u = w^2$, we have

$$F_e(w) \stackrel{a}{=} \frac{\ln(3+2\sqrt{2})}{\sqrt{2}} + \frac{\pi}{\sqrt{2}} j + e^{iw^2} \sum_{m=0}^n \frac{(-j)^{m+1} C_m}{2^m w^{2m+2}} \quad (\text{A5.12})$$

in which the error is at most

$$\frac{(2n+2)!}{(n+1)! 4^{n+1} (n+1) w^{2n+2}} + \frac{C_n}{2^n w^{2n+2}} \quad (\text{A5.13})$$

By (A5.6) and (A5.7), we compute

$$\begin{aligned} C_0 &= 1 \\ C_1 &= 1 \\ C_2 &= 7 \\ C_3 &= 27 \\ C_4 &= 321 \\ C_5 &= 2,265 \\ C_6 &= 37,575 \\ &\text{etc.} \end{aligned}$$

So we can write (A5.12) in the form

$$F_c(w) \doteq \frac{\ln(3 + 2\sqrt{2})}{\sqrt{2}} + \frac{\pi}{\sqrt{2}}j + e^{jw} \left(\frac{-j}{w^2} - \frac{1}{2w^4} + \frac{7j}{4w^6} + \frac{27}{8w^8} - \frac{321j}{16w^{10}} - \frac{2,265}{32w^{12}} + \frac{37,575j}{64w^{14}} + \dots \right)$$

We note the following approximate values:

$$\frac{\ln(3 + 2\sqrt{2})}{\sqrt{2}} = 1.2464504803 \quad \frac{\pi}{\sqrt{2}} = 2.2214414691$$

By (A5.7)

$$C_{2m-1} = (4m - 2)C_{2m-2} - \frac{(4m - 2)!}{(2m - 1)!2^{2m-1}} \quad (\text{A5.14})$$

$$C_{2m} = 4mC_{2m-1} + \frac{(4m)!}{(2m)!4^m} \quad (\text{A5.15})$$

So, by these two, we get

$$C_{2m} = 4(2m)(2m - 1)C_{2m-2} - \frac{(4m - 2)!}{(2m - 1)!2^{2m-1}}$$

Using this, one easily proves by induction on m that

$$C_{2m} \leq 2^{2m}(2m)!$$

Then, by (A5.14),

$$C_{2m+1} \leq 2^{2m+1}(2m + 1)!$$

So in general

$$C_n \leq 2^n n! \quad (\text{A5.16})$$

This information is useful for estimating the value of (A5.13).

TABLE 4.—FUNCTIONS FOR USE WITH JET DAMPING

w	$F_r(w)$	$F_j(w)$	w	$F_r(w)$	$F_j(w)$
0.0	0.0000	0.0000	2.0	1.0870	2.3911
0.1	0.2491	0.2323	2.1	1.0499	2.3043
0.2	0.4903	0.4344	2.2	1.0505	2.2140
0.3	0.7180	0.6152	2.3	1.0874	2.1358
0.4	0.9286	0.7825	2.4	1.1520	2.0838
0.5	1.1196	0.9423	2.5	1.2300	2.0677
0.6	1.2891	1.0993	2.6	1.3035	2.0897
0.7	1.4349	1.2567	2.7	1.3546	2.1429
0.8	1.5552	1.4160	2.8	1.3707	2.2122
0.9	1.6481	1.5773	2.9	1.3487	2.2773
1.0	1.7118	1.7392	3.0	1.2966	2.3184
1.1	1.7445	1.8988	3.1	1.2326	2.3229
1.2	1.7458	2.0516	3.2	1.1795	2.2907
1.3	1.7159	2.1922	3.3	1.1567	2.2350
1.4	1.6571	2.3141	3.4	1.1723	2.1787
1.5	1.5736	2.4110	3.5	1.2183	2.1458
1.6	1.4722	2.4768	3.6	1.2731	2.1497
1.7	1.3616	2.5075	3.7	1.3106	2.1878
1.8	1.2529	2.5012	3.8	1.3127	2.2397
1.9	1.1576	2.4603	3.9	1.2794	2.2778
2.0	1.0870	2.3911	4.0	1.2304	2.2814

BIBLIOGRAPHY

1. BLISS, G. A.: "Mathematics for Exterior Ballistics," John Wiley & Sons, Inc., New York, 1944.
2. BROMWICH, T. J. P.A.: "An Introduction to the Theory of Infinite Series," 2 ed., The MacMillan Company, New York, 1926.
3. DURAND, W. F.: Editor-in-chief, "Aerodynamic Theory," California Institute of Technology, Pasadena, 1943.
4. EPSTEIN, PAUL S.: "Textbook of Thermodynamics," John Wiley & Sons, Inc., New York, 1937.
5. HAYES, T. J.: "Elements of Ordnance," John Wiley & Sons, Inc., New York, 1938.
6. HERRMANN, E. E.: "Exterior Ballistics," U.S. Naval Institute, Annapolis, 1935.
7. "Ingalls' Ballistic Tables, Artillery Circular "M"" (Revised 1917), Government Printing Office, Washington, D.C., 1918.
8. JACKSON, DUNHAM: "The Method of Numerical Integration in Exterior Ballistics," War Department Document 984, Ordnance Textbook, Government Printing Office, Washington, D.C., 1921.
9. MACMILLAN, W. D.: "Theoretical Mechanics, Dynamics of Rigid Bodies," McGraw-Hill Book Company, Inc., New York, 1936.
10. MALINA, FRANK J.: "Characteristics of the Rocket Motor Unit Based on the Theory of Perfect Gases," *Journal of the Franklin Institute*, vol. 230 (1940), pp. 433-454.
11. PRANDTL, L., and O. G. TIETJENS: "Fundamentals of Hydro- and Aeromechanics," McGraw-Hill Book Company, Inc., New York, 1934.
12. PRANDTL, L., and O. G. TIETJENS: "Applied Hydro- and Aeromechanics," McGraw-Hill Book Company, Inc., New York, 1934.
13. ROSSER, J. BARKLEY: "Theory and Application of $\int_0^x e^{-x^2} dx$ and $\int_0^x e^{-x^2 y^2} dy \int_0^y e^{-x^2} dx$, Part I. Methods of Computation," Final Report B2.1 from Allegany Ballistics Laboratory, OSRD 5861. Copies are available in Federal Repository libraries. For further details, consult the OSRD Project of the Library of Congress.

14. STODOLA, A.: "Steam and Gas Turbines," translated by L. C. Loewenstein, McGraw-Hill Book Company, Inc., New York, 1927.
15. "Tables of Probability Functions," Vol. 1, 1941, Federal Works Agency, Work Projects Administration, under the sponsorship of the National Bureau of Standards.
16. "Tables of Lagrangian Interpolation Coefficients," Federal Works Agency, Work Projects Administration, Columbia University Press, 1944.
17. "Tables of Sine, Cosine and Exponential Integrals," Vol. 1, 1940, Federal Works Agency, Work Projects Administration, under the sponsorship of the National Bureau of Standards.
18. "Tables of Sine, Cosine and Exponential Integrals," Vol. 2, 1940, Federal Works Agency, Work Projects Administration, under the sponsorship of the National Bureau of Standards.
19. "Table of Sine and Cosine Integrals for Arguments from 10 to 100," 1942, Federal Works Agency, Work Projects Administration, under the sponsorship of the National Bureau of Standards.

GLOSSARY OF SYMBOLS

For those of the symbols which relate particularly to rockets, we have given sample numerical values. In the main, these are based on the M8 rocket, but we have not attempted to secure complete consistency in this matter.

We make general use of certain devices for giving especial significance to symbols, namely, the use of a dot over a symbol to denote a derivative with respect to time, and the use of the subscripts p and b to denote the values at the end of launching and at the end of burning. Other subscripts are less generally used and are noted under the appropriate symbol. If a symbol with a subscript does not appear explicitly in the glossary, one should look up the symbol and the subscript separately.

Symbols that are introduced for strictly temporary use and are defined in the context are generally not listed.

Many symbols appear only in a limited portion of the book. In such case, the range of occurrence is indicated. Symbols that have a different significance in different portions of the book are listed more than once, with an indication of the range of occurrence for each listing.

Certain special symbols used only in Appendix 2 and adopted from Reference 9 are not listed.

SYMBOLS

<i>A</i>	Chap. I and Appendix 1, area of nozzle cross section.
<i>A</i>	Chap. II, coefficient in the formula for δ , see (II.4.11) and (II.4.9). For sample values, see Fig. II.6.1.
<i>a</i>	Chap. II and Chap. III, constant in formula $\rho = \rho_0 e^{-ay}$. Sample value: $0.0000316 \text{ ft}^{-1}$.
<i>A₁, A₂</i>	Chap. II, coefficients in the formula for δ , see (II.4.11), (II.4.22), and (II.4.23).
<i>B</i>	Chap. II, coefficient in the formula for δ , see (II.4.11) and (II.4.8). Sample value: 0.0015 ft^{-1} .
<i>b</i>	Used as a subscript to denote the value at the end of burning.
<i>c</i>	Appendix 1, used as a subscript to denote the value in the rocket chamber.
<i>C_D</i>	Appendix 1, discharge coefficient, see (A1.14). Sample value: 6.58×10^{-6} in CGS units.
<i>C_m</i>	Appendix 5, coefficient in asymptotic expansion, see (A5.5), (A5.6), (A5.7), and (A5.12).
<i>C_P</i>	Appendix 1, specific heat at constant pressure.
<i>C(u)</i>	Chap. V, Fresnel integral, defined by (V.5.2).
<i>Ci(w)</i>	Chap. III, cosine integral, defined by (III.7.61).
<i>D</i>	Chap. I, drag, see (I.2.1).
<i>d</i>	Rocket diameter. Sample value: 0.375 ft .
<i>E</i>	Chap. IV, coefficient defining the rigidity of a launcher, see (IV.2.8).
<i>e</i>	Chap. I and Appendix 1, used as a subscript to denote the value at the nozzle exit.
exp	When x is complicated, e^x is simplified to exp (x).
<i>F</i>	Chap. I, resultant of miscellaneous forces on a rocket, see (I.1.2). Sample value: zero.
<i>F_a</i>	Chap. I, aerodynamic force on a rocket, see (I.1.2).
<i>F₁, F₂</i>	Chap. I, miscellaneous forces on a rocket, see (I.5.6), (I.5.7V), and (I.5.7H). Sample value: zero.
<i>F₁, F₂, F₃, F₄</i>	Chap. III, coefficients in the formula for δ , see (III.1.28), (III.1.48), (III.1.49), (III.1.50), and (III.1.51).
<i>F(w)</i>	Appendix 4, special function, see (A4.1) and Table 3.
<i>f(δ)</i>	Chap. III, Sec. 15, temporarily used to denote the function graphed in Fig. III.15.1.
<i>F₀(w)</i>	Appendix 5, special function, see (A5.1).

- $F_r(w), F_i(w)$ Appendix 5, real and imaginary parts of $F_c(w)$, see Table 4.
- G Except in Appendix 2, acceleration due to the rocket jet ($= T/M$). Sample value: 6,000 ft/sec².
- g Acceleration due to gravity. Sample value: 32.2 ft/sec².
- g_x Chap. I, component of gravity, see (I.1.2).
- G_c Chap. III, Sec. 10, coefficient in approximate equation for G , see (III.10.1). Sample value: 6,936 ft/sec².
- G_1, G_2, G_3, G_4 Chap. III, coefficients in the formula for θ , see (III.1.6), (III.1.7), (III.1.8), (III.1.9), (III.1.10), (III.1.52), (III.1.53), (III.1.54), and (III.1.55).
- H Chap. I, damping moment, see (I.2.5).
- h_D Chap. III, reduced normalized drag coefficient, see (III.3.16). Sample value: 0.0020.
- h_G Chap. III, Sec. 10, coefficient in approximate equation for G , see (III.10.1). Sample value: 0.1760.
- h_X Chap. III, reduced normalized damping coefficient, see (III.3.18). Sample value: 0.073.
- h_J Chap. III, reduced normalized jet damping coefficient, see (III.3.19). Sample value: 15.3 ft³ sec⁻¹.
- h_L Chap. III, reduced normalized lift coefficient, see (III.3.17). Sample value: 0.022.
- h_s Chap. III, reduced normalized cross-spin coefficient, see (III.8.4). Sample value: 0.0022.
- I Moment of inertia, usually about a transverse axis. Sample value: 20 lb ft².
- i Chap. III, Sec. 4, form factor. Sample value: 200/ ρ at sea level.
- i Chap. II, used as a subscript to denote elements of the idealized or particle trajectory.
- $I_1(u), I_2(u)$ Chap. III, Sec. 14, special functions, see (III.14.5) and (III.14.6).
- $ic(w)$ Rocket function, see (V.1.6) and (V.1.7).
- $\bar{ic}(w)$ Conjugate complex of $ic(w)$, see (V.1.7) and (III.1.38).
- $id(u)$ Chap. III, Sec. 14, special function, see (III.14.7).
- $ir(w), ij(w)$ Rocket functions, real and imaginary parts of $ic(w)$, see (V.1.7), (V.1.8), (V.1.9), (V.1.16), and Table 1.
- $IF(w), I\phi(w)$ Appendix 4, special functions, see (A4.3), (A4.4), and Table 3.
- J Chap. I, resultant of miscellaneous torques. Sample value: zero.

j	Square root of -1 , see (V.1.1). This is used instead of the more familiar symbol i .
J_a	Chap. I, torque due to aerodynamic forces.
k	Except in Chap. V, radius of gyration, usually about a transverse axis. Sample value: 0.75 ft.
k	Chap. V, a positive constant.
K_D	Drag coefficient, see (I.2.1). Sample value: 0.204.
k_D	Reduced drag coefficient, see (II.4.3). Sample value: 0.0058 lb^{-1} .
k_d, k_s	Coefficients in the approximate equation for k_D , see (II.5.1). Sample values: $k_d = 0.0058 \text{ lb}^{-1}$, $k_s = 0.125 \text{ lb}^{-1}$.
K_H	Damping coefficient, see (I.2.5). Sample value: 31.6.
k_H	Reduced damping coefficient, see (II.4.7). Sample value: $1.58 \text{ lb}^{-1} \text{ ft}^{-2}$.
k_J	Chap. III, reduced jet damping coefficient, see formula after (III.3.12). Sample value: 2.71 sec^{-1} .
K_L	Lift coefficient, see (I.2.2). Sample value: 2.33.
k_L	Reduced lift coefficient, see (II.4.4). Sample value: 0.067 lb^{-1} .
K_M	Moment coefficient, see (I.2.4). Sample value: 6.32.
k_M	Reduced moment coefficient, see (II.4.6). Sample value: $0.316 \text{ lb}^{-1} \text{ ft}^{-2}$.
K_s	Cross-spin coefficient, see (I.2.3). Sample value: 20.4.
k_s	Reduced cross-spin coefficient, see (II.4.5). Sample value: 0.58 lb^{-1} .
L	Chap. I, Sec. 2, lift, see (I.2.2).
L	Except in Chap. I, Sec. 2, jet malalignment distance, see Fig. I.5.1. Sample value: 0.004 ft.
l	Distance from the center of gravity to the center of pressure, see (I.2.8). Sample value: 0.94 ft.
M	Except in Chap. I, Sec. 2, mass of the rocket and unburnt fuel. Sample value: 35 lb.
M	Chap. I, Sec. 2, restoring moment, see (I.2.4).
m	Amount of propellant fuel already burnt at a given time.
P	Chap. I and Appendix 1, pressure in the gas stream.
P	Chap. III, dimensionless launcher length, see (III.1.19).
p	Chap. III, launcher length.
p	Used as a subscript to denote the value at the end of the launcher.
P_a	Chap. I and Appendix 1, atmospheric pressure.

- q Chap. IV, the distance from the center of gravity to the cross section of the rocket containing the point of support, see Fig. IV.2.2. Sample value: 1 ft.
- R Chap. II, length of rotating arm in Fig. II.3.1.
- r A generic symbol used to denote a distance from the axis of a rotating rocket. For spinning rockets, r is the distance from the axis of the rocket. For a yawing rocket, r is the distance from a transverse axis through the center of gravity. Thus it comes about that r_e and r_t denote the distances from the center of gravity of the rocket to the exit and throat of the nozzle, respectively (see under e and t for their use as subscripts).
- R_x, R_y Fictitious accelerations involved in the forces exerted by a launcher on a rocket, see (IV.2.1), (IV.2.2), and (IV.2.3).
- $ra(w)$ Rocket function, see (V.1.10), (V.1.11), (V.1.13), and Table 1.
- $ra^2(w)$ Rocket function, see (V.1.10), (V.1.11), and Table 1.
- $rc(w)$ Rocket function, see (V.1.2), (V.1.3), (V.1.13), and Table 1.
- $\bar{rc}(w)$ Conjugate complex of $rc(w)$, see (V.1.3) and (III.1.27).
- $rr(w), rj(w)$ Rocket functions, real and imaginary parts of $rc(w)$, see (V.1.3), (V.1.4), (V.1.5), and Table 1.
- $rt(w)$ Rocket function, see (V.1.12), (V.1.13), and Table 1.
- S, S^* Chap. I, Sec. 1, systems of particles.
- S Chap. I, Sec. 2, cross-spin force, see (I.2.3).
- S Chap. II and Chap. III, dimensionless distance along trajectory, see (III.1.16).
- s Distance along the trajectory.
- s Chap. III, used as a subscript in $G_s, v_{ps}, \delta_{ps}, \theta_s, \theta_{ps}, \sigma_s$, and ϕ_{ps} to denote the value of $G, v_p, \delta_p, \theta, \theta_p, \sigma$, and ϕ_p for the standard rocket.
- $S(u)$ Chap. V, Fresnel integral, defined by (V.5.3).
- $Si(w)$ Chap. III, sine integral, defined by (III.7.62).
- T Thrust of a rocket. Sample value: 240,000 pounds.
- t Time.
- t Chap. I and Appendix 1, used as a subscript to denote the value at the nozzle throat.
- u Chap. III, normalized velocity, see (III.3.15).
- v Velocity. In ballistic parlance, the term is used carelessly, often being applied to undirected magnitudes,

	for which the term "speed" would be preferable.
v_a	Velocity of the launcher relative to the air (= speed of airplane for rockets fired from an airplane).
V_b	Chap. III, Sec. 5, burnt velocity of the rocket relative to the launcher.
v_E	Effective gas velocity, see (I.1.1) and (I.1.4). Sample value: 7,300 ft/sec.
v_{ps}	v_p with a subscript s attached.
w	Except in Appendix 3, mathematical variable.
w	Appendix 3, velocity of the metal framework of the rocket.
x, y	Coordinates of the center of gravity of the rocket. Commonly x is taken horizontal and y vertical (see Chap. I, Sec. 3). Special coordinate systems may be introduced for special purposes (see Fig. IV.2.2).
x, y, z	Mathematical variables.
Γ	Rate of rotation of a spinning rocket in radians of rotation per foot of forward travel.
γ	Except in Chap. V, Sec. 7, or Appendix 1, rate of rotation of a spinning rocket in revolutions per wave length of yaw ($\gamma = \sigma\Gamma/2\pi$).
γ	Chap. V, Sec. 7, the Euler-Mascheroni constant.
γ	Appendix 1, exponent in equation for adiabatic expansion, see (A1.4).
Δ	Placed in front of a symbol to denote "increment of." For instance, Δv^2 and $\Delta\theta$ in Chap. II, Sec. 5, $\Delta\delta$ in Chap. III, Sec. 9, $\Delta\psi$ in Chap. III, Sec. 13.
δ	Angle between the longitudinal axis of the rocket and the direction of motion of the rocket, see Fig. I.1.4. Usually referred to as the "angle of yaw."
Δ_L	Value of lift malalignment angle at the origin of coordinates, see (II.4.2). Sample value: 0.015 j rad.
δ_L	Lift malalignment angle, see (I.2.2*), page 27.
Δ_M	Value of fin malalignment angle at the origin of coordinates, see (II.4.1). Sample value: 0.010 rad.
δ_M	Fin malalignment angle, see (I.2.4*), page 28.
δ_{ps}	δ_p with a subscript s attached.
δ_R	A term in the equation for δ , consisting of the yaw of repose, see (II.4.11) and (II.4.10).
Δ_T	Value of jet malalignment angle at the origin of coordinates, see (III.12.2). Sample value: 0.005 j rad.
δ_T	Jet malalignment angle, see Fig. I.5.1. Sample value: 0.005 rad.

- η Separation between the actual and idealized trajectories, see Fig. II.2.1.
- θ Angle between the reference axis and the direction of motion of the rocket, see Fig. I.1.4.
- θ_a Value of θ for the approximate trajectory described in Chap. I, Sec. 3, see Fig. I.3.3 and page 44.
- θ_{ps} θ_p with a subscript s attached.
- Δ Chap. III, value of jet malalignment distance at the origin of coordinates, see (III.12.1).
- μ Chap. IV, "coefficient of friction," defined by (IV.2.5).
- ρ Except in Appendix 1, air density.
- ρ Appendix 1, density of gas in the jet.
- ρ_0 Chap. II and Chap. III, constant in formula $\rho = \rho_0 e^{-\alpha y}$. Sample value: 0.073 lb/ft³.
- Σ Used to denote summation.
- σ Wave length of yaw, see (I.2.13). Sample value: 200 ft.
- ϕ Angle between the reference axis and the longitudinal axis of the rocket, see Fig. I.1.4.
- ϕ_{ps} ϕ_p with a subscript s attached.
- $\phi(w)$ Appendix 4, special function, see (A4.2) and (A4.8).
- ψ Angle denoting the amount of rotation of a rocket about its longitudinal axis.
- Ω Chap. III, Sec. 13, angular velocity of a spinning rocket in radians per second.
- ω Chap. III, Sec. 13, a parameter related to the angular velocity of a spinning rocket, specifically
- $$\omega = \left(\frac{1}{2}\right)\Omega \sqrt{\sigma/\pi G}.$$
- \cdot A dot over a symbol denotes a derivative with respect to time.
- ' Except in Appendix 2, a prime on a symbol denotes a derivative with respect to the dimensionless distance S .
- \approx Approximately equal.
- \asymp Asymptotically equal, used between a function and its asymptotic series.

INDEX

A

- Acceleration, nonuniform, 136-140
 - rocket, 7-10
 - sidewise, 42
- Aerodynamic forces, 8-9, 23-24
 - designation of, 23-24
 - effect of jet action on, 33-34
 - physical background for, 24-30
 - typical data for, 30-33
- Analogue of Principle III, 16, 22
- Angular momentum, 13
 - conservation of, 11
- Arc length, 38, 42, 47, 82
 - dimensionless, 66, 90
- Asymmetry, 27, 28, 35, 60

B

- Basic solution, 81-90
 - for firing, from aircraft, 118-123
 - in a vacuum, 123-125
- Bazooka, 1, 50, 51
- Burning, end of, 50, 140
- Burning distance, 119
- Burnt velocity, 10-11, 116-118, 119

C

- Center of gravity, coordinates of, 38
 - effect of shift of, 247-250
- Center of pressure, 27-30
- Chamber, 1, 237-242
- Coefficient, discharge, 240-241
 - of friction, 189
 - jet damping, 110
- Conservation, of momentum, 3
 - of angular momentum, 11
- Coordinate system, during flight, 34-39
 - during launching, 188, 193-194
- Cross-spin force, 24
 - correction for, to basic solution, 131-134

- Cross-spin force, dispersion due to, 74-75
 - origin of, 29-30
- Cross-wind force, 24

D

- Damping, aerodynamic, 24, 30, 131-134
 - jet (*see* Jet damping)
- Damping moment, 24, 30
 - effect of, 131-134
- Deviation from approximate trajectory, 95
- Discharge coefficient, 240-241
- Dispersion, 50-57, 88
 - ammunition, 50-51
 - after burning, 50, 75 (lines 5-8)
 - computation of, 55-57
 - due to cross-spin force, 74-75
 - definition of, 53-55
 - for a different rocket, 75
 - formulas for, 73, 75 (lines 5-8)
 - due to lift, 72-74
 - numerical example of, 77
 - reduction of, by a slow spin, 59-60
 - solution for, 67-69, 72-75
 - sources of, 57-58
 - due to yaw drag, 69-72
 - during burning, 78-81
 - from aircraft, 106-107, 118-123
 - with constant angular acceleration, 141-153
 - with constant angular velocity, 153-162
 - experimental verification of, 173-183
 - formula for, 82-90
 - importance of various sources of, 173-183
 - L-type, 179-183
 - with large initial yaw, 167-173
 - minor effects of, 131-141
 - numerical examples of, 97-107

Dispersion, during burning, of unstable rocket, 162-167
 in a vacuum, 123-125
 latent, 52, 54, 78, 80, 185
 method of computation of, 55, 88
 true, 52
 velocity, 175

Drag, 24-25
 effect of, 136-140
 Mayevski function of, 116
 variations of, due to jet action, 33-34

E

Everett's interpolation coefficient, 216, 234-236
 Everett's interpolation formula, 216
 Exit pressure, 1, 8, 241
 Exit velocity, 1, 4, 7, 241-242
 Expansion ratio, 5

F

Fin malalignment angle, 88
 Fins, 20, 141, 181
 bent, 28, 60
 folding, 162, 165, 193
 Force, momentum, 16
 pressure, 16
 (*See also* Aerodynamic force; Cross-spin force; Cross-wind force; Gravity; Jet forces)

Form factor, 116
 Fresnel integrals, 92, 206, 207
 Functions, rocket (*see* Rocket functions)

G

Gas velocity, effective, 4-5, 10-11
 computation of, 237-242
 Gravity, 39
 force due to, 8
 Gravity drop, 88
 Gyration, radius of, 13
 transverse, 21, 89

H

Hale, William, 12

I

Interpolation, accuracy of, in Table 1, 215-219
 in Table 2, 216-217
 in Table 3, 255-256
 in Table 4, 258

J

Jet action, effect of, on aerodynamic forces, 33-34
 Jet damping, 19-23, 173
 effect of, 134-136
 functions for use with, 258-262
 Jet damping coefficient, 110
 Jet flow, simplified theory of, 237-242
 Jet forces, 1-23
 classical derivation of, 3-5
 minor effects of, 247-252
 momentum forces, 16
 physical picture of, 16-19
 pressure forces, 16
 thrust, 8-9
 Jet malalignment angle, 41, 88
 Jet malalignment distance, 41, 88, 179-183

L

Launcher, 78, 184-195
 effective length of, 82, 119-123, 138-139
 end of, 184
 fixed support, 193-195
 flexible, 185, 190-193
 moving support, 188-193
 oscillations of, 192
 rigid, 185, 187-190, 193-195
 slotted rail, 188
 tipping-off from, 187-195
 trough, 193
 tube, 188, 193
 zero-length, 50, 105, 188
 Launcher length, effective, 82, 119-123, 138-139
 Launcher velocity, 119-123, 185-187
 Lift, 24, 26, 27, 57
 dispersion due to, 72-74, 131-134

M

- M8 rocket, 31, 45, 61, 62, 72, 109, 110, 111, 169, 180, 181, 182, 265
- M9 rocket, 180, 183
- Malalignment, aerodynamic, 27-28
 gas, 179
 mechanical, 179
 of thrust, 41
 (*See also* Fin malalignment angle;
 Jet malalignment angle)
- Malformation, 27, 28, 40
- Moment, damping, 24, 30, 131-134
 of a force, 14
 of inertia, 13
 of momentum, 11-13, 243-246
 restoring, 24, 26-28
 upsetting, 162-163
- Momentum, angular, 13
 conservation of, 3
 moment of, 11-13, 243-246
- Momentum forces, 16
- Motion, after burning, 49-77
 trajectory idealized, 53-54, 67-69
 particle, 53-54, 67-69
 standard, 51, 54, 184
 vacuum, 53
- during burning, 78-183
 effect of, cross-spin force, 131-134
 damping moment, 131-134
 drag, 136-140
 jet damping, 134-136
 lift, 131-134
 nonuniform acceleration, 136-140
 variable wave length of yaw, 140-141
- equations for, general, solution of, 107-116
 simplified, solution of, 83, 90-97
 initial yaw, large, 167-173
 numerical examples of, 97-104, 104-107
 velocity of, solution for, 116-118
 with spin, 141-153, 153-162
- equations of, 39-48
 periods of, 49
 spinning, 12-19, 59-66, 141-162
 yawing, 20

N

- Newton, Sir Isaac, 24
- Nielsen, K. L., 28
- Nozzle, 1-3
 canted, 12-19
 drilled, 12, 14-19
 effect of lopsidedness of, 19
 flow through, 237-242
 insert, 12, 14-19
 malalignment of, 40-41
 parts of, 2

P

- Pitching force, 24
- Pressure, atmospheric, 8
 center of, 27-30
 chamber, 1, 237-238
 exit, 1, 8, 241
 jet, 8
 static atmospheric, 8
- Pressure forces, 16
- Principle I, 6, 10
- Principle II, 6-7
- Principle III, 10, 42-43
 analogue of, 16, 22
- Principle IV, 11
- Principle V, 11-15, 42
 derivation of, 243-246

R

- Repose, yaw of, 58-59, 61
- Resonance, 59, 71, 74
- Restoring moment, 24, 26-28
- Rigidity of the trajectory, 55
- Rockets, spinning, 12-19, 59-65, 141-162
 stable, 24, 27
 standard, 51, 79, 88, 184
 unstable, 24, 27, 162-167, 253-257
 functions for use with, 253-257
- Rocket functions, 92-97, 125-134, 196-233
 accuracy of interpolation in Table 1, 215-219
 asymptotic expansions, 210-213
 computation of, by special means, 213-215

Rocket functions, definition of, 196
 derivatives of, 198
 integrals of, 198-206
 notation for, 196-197
 power series for, 208-210
 relations of, with other functions,
 206-208
 in solution of equations, 92-97
 tables of, 220-233
 useful relations of, 125-131
Rotation, equations for, 11-16

S

Solution, for dispersion after burning,
 67-69, 72-75
 general, during burning, 107-116
 simplified, during burning, 83, 90-97
 for yaw after burning, 60-61
 for yaw during burning, 93
Sound, velocity of, 2, 239-240
Spin, 12-19
 equations of motion, 59-66, 141-162
Spinner rocket, 12-19
Standard rocket, 51, 79, 88, 184
Syngé, J. L., 28

T

Thrust, 8, 9, 42-43
 malalignment, 40-41
 nonuniform, 136-140
Tipping-off, 184, 187-195
Trajectory, actual, 37
 approximate, 36-37, 76
 curvature of, 61, 63
 idealized, 53-54, 67-69
 particle, 53-54, 67-69
 rigidity of, 55
 standard, 51, 54, 184
 vacuum, 53

V

V-2 rocket, 1, 250
Velocity, 269-270

Velocity, angular, 13
 initial, 88, 91, 98, 105, 189, 195
 burnt, 10-11, 116-118, 119
 dispersion, 175
 during burning, special solutions for,
 116-118
 effective gas, 4, 10, 242
 at end of burning, 10-11, 116-118,
 119
 exit, 1, 4, 7, 241-242
 of sound, 2, 239-240
 ultimate gas, 4, 240, 242

W

Wave length of yaw, 32, 34, 65
 measurement of, 32
 variable, 140-141
Wind, cross-range, 186

Y

Yaw, 20-21
 after burning, derivation of, 62-66
 expression for, 60-61
 more accurate, 66-67
 numerical considerations of, 61-62
 during burning, 93
 caused by resonance, 61
 conical, 20
 effect of, on drag, 25
 on lift, 26
 on restoring moment, 26
 effective, 29
 initial, 88, 99, 105, 185-187
 large, 167-173
 of repose, 58-59, 61
 standard, 79
 wave length of, 32, 34, 65

Z

Zero-length launcher, 50, 105, 188

