

UNIVERSAL
LIBRARY

OU_166484

UNIVERSAL
LIBRARY

OSMANIA UNIVERSITY LIBRARY

Call No. 544/S43E Accession No. 32959

Author

Scott, Wilfred, Welda

Title

Elements of Qualitative

This book should be returned on or before the date last marked below.

Elements of Qualitative Chemical Analysis

A Laboratory Guide

BY

WILFRED WELDAY SCOTT, Sc.D.

Late Professor of Chemistry, University of Southern California; Author "Standard Methods of Chemical Analysis," "Chemical Methods in Metallurgical Analysis," "Essentials of Quantitative Chemical Analysis," etc.

SECOND EDITION—SECOND PRINTING

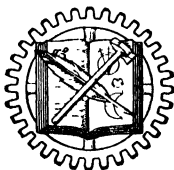

NEW YORK
D. VAN NOSTRAND COMPANY, INC.
250 FOURTH AVENUE

COPYRIGHT, 1928, 1932

BY

D. VAN NOSTRAND COMPANY, Inc.

All Rights Reserved

*This book or any parts thereof may not
be reproduced in any form without
written permission from the publishers.*

First Published, June 1928

Reprinted October 1929, January 1930

Second Edition, August 1932

Reprinted March 1936

Printed in U. S. A.

PRESS OF
BRAUNWORTH & CO., INC.
BOOK MANUFACTURERS
BROOKLYN, NEW YORK

To the Student who uses this Textbook:

This textbook represents many years of learning and experience on the part of the author. It does not treat of an ephemeral subject, but one which, since you are studying it in college, you must feel will have a use to you in your future life.

Unquestionably you will many times in later life wish to refer to specific details and facts about the subject which this book covers and which you may forget. How better could you find this information than in the textbook which you have studied from cover to cover?

Retain it for your reference library. You will use it many times in the future.

The Publishers.

PREFACE TO THE SECOND EDITION

THE original plan of the first edition is retained in this revision to hold the text to the essentials of qualitative chemical analysis, keeping in mind the desired brevity of a short course, but with sufficient detail for clear presentation. An effort has been made to include the more recent advancements made in qualitative tests and present the best methods of separation of the elements and their identification. With this in view some changes have been made, notably in the ammonium sulfide group, where a simpler method of separation has been given and the more lengthy method of the first edition abandoned. A section has been included on a procedure for separation and identification of the elements without the use of hydrogen sulfide. The purpose of this section is to offer an interesting study for those who are familiar with the standard methods that have long been known. Some changes have been made in Part II. The author has purposely avoided expansion, a tendency so common in revisions. It has been felt that a method that has been improved should be replaced by the better procedure. As it is very desirable for the student to do outside reading a bibliography of recent interesting methods has been given as a suggestion for library work.

WILFRED W. SCOTT.

LOS ANGELES,
January, 1932

PREFACE TO FIRST EDITION

QUALITATIVE chemical analysis employs fundamental principles that have been studied in the preceding course in general chemistry. The subject is commonly taken up in conjunction with a course in chemistry dealing with the metals. The student has become familiar with Le Chatelier's principle, the law of molar concentration, principles of equilibrium, solubility product, common ion effect and the modern conception of matter, including the proton-electron theory. No attempt is made, therefore, to review this matter other than to point to applications as the occasions arise. Likewise it is taken for granted that the student is familiar with common laboratory manipulations, filtration, handling reagents, conducting ignitions and using glassware, test tubes, beakers and flasks.

In studying the metals under the customary group divisions, a preliminary study of the individual elements is first considered, beginning with an outline of the tests that are to be made. In this study the student is required to make the individual tests side by side to show the reactions that are used in the separation of the elements. These tests can be conducted in beakers, flasks or test tubes placed in a suitable rack. In experiments where hydrogen sulfide is used the flasks or test tubes are connected in series and the solutions saturated with the gas at one time. These comparative tests have special merit in fixing in the students' minds the reactions that take place and the reasons for the steps in the procedures that follow.

Since the period that is devoted to qualitative analysis seldom exceeds one semester, an effort has been made to compile a text that includes the essentials and eliminates unnecessary detail. For short courses it may be advisable to have the students begin

immediately with the group separations, starting with a known mixture of all the elements of the group and following the directions in the tables on the groups. An "unknown" may now be examined, upon acquiring experience with the "known."

The group charts will be found to be helpful in obtaining a general survey of the tables. These charts should be memorized. It is a good plan to have the student copy these in a notebook and to enter, by means of crayons, the colors of precipitates and solutions in the rectangles and circles. These diagrams, suggested by Prof. Hodge (*J. Chem. Ed.*, 6, 242. Feb., 1927) have been found to be very effective in clarifying the steps of the separations and fixing in the mind formulae of the compounds formed. Since using the charts, the author has found a decided improvement in the class work by the students and an evidence of greater interest in the subject.

In the paragraphs following laboratory directions a summary is made of principles involved in the sections outlined. Lengthy dissertations are purposely avoided as being confusing rather than helpful, an effort being made to present the facts concisely with a watchful regard for essentials.

In the questions that follow each group, a review is made of the facts presented of that group. A study of the questions by home assignments is recommended.

The procedures have been carefully chosen and thoroughly tested before being incorporated in the text.

The table of solubilities at the close of the text was contributed by Professor W. D. Leech.

WILFRED W. SCOTT.

University of Southern California,
June 1, 1928

CONTENTS

	PAGES
Introduction. Apparatus, Preparation of the Solution, Precipitation, Filtration, Precautions Washing Precipitates, Acidity and Alkalinity Tests, Cleaning Apparatus, Reagents.	1-7
Part. I. The Metals, or Cations. —Groups and Members, Study of Group Separations, Outline Table and Chart.	9-13
<i>Hydrogen-Chloride or Silver Group.</i> —Preliminary Tests of Elements of the Group, Table of Separations, Summary Chart of Separations, Chemical Principles, Displacement of Electromotive Series, Classroom Review, Group Reactions.	14-24
<i>Hydrogen-Sulfide Group.</i> —Preliminary Tests of the Insoluble H ₂ S, Copper Subdivision and of the Soluble H ₂ S Tin Division Groups, Table of Separations and Charts, Chemical Principles, Classroom Review, Group Reactions.	25-53
<i>Ammonium Sulfide Group.</i> —Preliminary Tests, Interfering Substances, Study of Reactions, Tables and Charts of Separations, Chemical Principles, Classroom Review, Group Reactions.	54-77
<i>Ammonium Carbonate Group, the Alkaline Earths.</i> —Preliminary Tests, Tables and Charts of Separations, Chemical Principles, Classroom Review, Group Reactions.	79-88
<i>The Soluble Group, Magnesium and the Alkalies.</i> —Preliminary Tests, Table and Chart of Separations, Chemical Principles, Classroom Review, Group Reactions, Summary Chart of All Groups.	89-97
A suggested procedure of separations, charts and tables, omitting the use of hydrogen sulfide.	98-103
Part II. The Acids, or Anions. —Members of Groups <i>Barium Reagent or Sulfate Group.</i> —Preliminary Individual Tests. <i>Silver Reagent or Chloride Group.</i> —Preliminary Individual Tests. <i>Soluble Acids or Nitrate Group.</i> —Preliminary Individual Tests. Separation and Detections of the Acids, Tables, Notes on the Analysis of Acids, Classroom Review, Acid Reactions.	105-125

	PAGES
Part III. Systematic Analysis of Substances. —Preparation of the Solution, Liquids and Solids; Summary of Analysis of the Cations or Basic Elements, the Metals; Summary of Analysis of the Anions or Acid Radicals; Suggestions and Notes, General Summary Table of Tests of the Acids	127–141
Part IV. Reagents. —Acids and Alkalies, Salt Solutions, Solid Reagents, Special Reagents, Test Solutions	143–149
Appendix. —Blowpipe Tests—Tables of Tests, Flame Tests, Identification of Substances by Their Crystal Form	151–156
Index	157
Table of Atomic Weights	Front Cover
<i>Table of Solubilities</i>	Back Cover

LIST OF ILLUSTRATIONS

FIGURE	PAGE
1. Saturation with H ₂ S, a Battery of Solutions	3
2. Filtration	3
3. Filtering by Suction	4
4. Wash Bottle	6
5. Reagent Bottle for Test Solutions	7
6. Test for CO ₂	108
7. Test for Fluoride	109
8. Decomposition of Substances	128
9. Test for CO ₂ and H ₂ S	136
10. Regular or Isometric System	153
11. Tetragonal System	154
12. Hexagonal System	154
13. Rhombic System	154
14. Monoclinic System	155
15. Triclinic System	155
CHARTS	
A. Separation of the Basic Groups	13
I. Hydrogen-Chloride or Silver Group	19
II. A. Hydrogen-Sulfide Group. Copper and Tin Divisions	38
II. B. Separation of the Tin Division of the Hydrogen-Sulfide Group	39
III. Ammonium-Sulfide Group. Separation of Sub-groups	64
IV. Ammonium-Carbonate Group, the Alkaline Earths	84
V. Soluble Group, Magnesium and the Alkalies	93
VI. Summary—All Basic Groups	97
VII. Outline of Separations without the Use of H ₂ S—Separation of Groups	99
VIII. Insoluble Sulfate Group	100
IX, A. The Hydroxide Group	101
IX, B. Subgroup, B.	102
* X. Soluble Amphoteric Group	103
Table of Atomic Weights	Front Cover
Solubility Table	Back Cover

INTRODUCTION

§ 1. THE study of qualitative analysis deals with the identification of substances and with the chemical principles involved in this identification. A general chemistry course and previous laboratory experience are of necessity required as a background before undertaking work in the interesting field of analytical chemistry.

In this course, we will take up the study of cations, anions, and a systematic examination of a composite substance; considering first, the cations, or the metals forming positive ions; and next, the anions, or acid radicals or combinations of negative character; concluding with the study of some composite substance. The data placed at the end of the text will be found valuable throughout the course.

The subject-matter in this work should be thoroughly studied and then taken up in the laboratory. All directions should be followed with the utmost care. The reagents used have a certain concentration and the test solutions contain definite amounts of the elements so that a knowledge of quantities is gained in the qualitative tests.

§ 2. **Apparatus.**—Although beakers and test tubes are indispensable, it is advisable to use the Erlenmeyer flasks for hydrogen sulfide precipitations. Heating and rapid evaporations may be conducted in the flasks by holding them slightly tilted, by means of heavy wire holders (Fig. 8), directly over a flame. Evaporations to dryness are preferably conducted in pyrex beakers or in porcelain dishes or casseroles. Containers of 150 to 250 cc. capacity are ample for conducting the work. The volumes of the solutions should be kept as small as possible. This is accomplished by saving only the filtrates and first washing of the precipitates

with rejection of the subsequent washings; and by concentration of the solutions by boiling these filtrates to small volumes.

§ 3. **Preparation of the Solution.**—Details for dissolving solids may be found in the third part of this text under the scheme of systematic examination of substances. If the substance is a solution of unknown acidity, the free acid may be carefully neutralized with NH_4OH (NH_3 should be tested for on a small separate portion) and then made slightly acid, using litmus paper as indicator. If the solution is alkaline, it is made faintly acid with hydrochloric acid which is preferred to nitric or sulfuric acids since nitric interferes with precipitations of the sulfide groups, while sulfuric acid causes precipitation of lead and barium. On the other hand hydrochloric will precipitate as chlorides the first group containing silver, monovalent mercury, and lead.

§ 4. **Precipitation.**—The reagents are added in sufficient amount to completely precipitate the substances in question, but not in a great excess, since the volumes would become unduly large, requiring boiling down for convenient handling. It is always advisable to test the filtrates with additional reagent to ascertain whether a sufficient amount has been added. For example in the precipitation of the H_2S group, arsenic sulfide precipitates slowly and the H_2S treatment of the filtrate should be always carried out, otherwise arsenic will pass into subsequent groups. Colloids passing through the filters may cause trouble, boiling generally causes their coagulation. Addition of ammonium salts frequently assist in their precipitation.

Precipitates, gelatinous in nature, such as $\text{Fe}(\text{OH})_3$, $\text{Al}(\text{OH})_3$, etc., will *adsorb* substances. Even crystalline precipitates possess this character. SrSO_4 adsorbs Fe^{+++} , Al^{+++} , Cr^{+++} , Ni^{++} , Co^{++} , Cu^{++} but not Hg^{++} ; BaSO_4 and CaSO_4 adsorb Fe^{+++} ; $\text{Fe}(\text{OH})_3$, $\text{Al}(\text{OH})_3$, and $\text{Cr}(\text{OH})_3$ adsorb Zn^{++} , Cu^{++} , Ni^{++} , Cd^{++} and Ca^{++} but not Ag^+ ; BaCO_3 , CaCO_3 , SrCO_3 adsorb Fe^{+++} , and Mg^{+} .

Precipitation of sulfides by H_2S , where several samples are

treated at one time, is best accomplished in flasks connected in series, as is shown in Fig. 1. The air is driven out by the current of H_2S and the exit at the end of the series is now closed by a

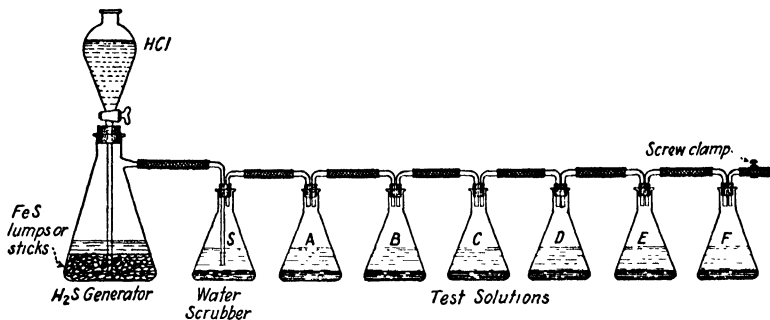

FIG. 1.—Saturation with H_2S , a Battery of Solutions.

screw clamp or pinch cock, and the gassing continued as long as the solutions absorb H_2S . The stop cock of the H_2S generator, governing the acid flow, is left open to allow the acid to pass back into the upper reservoir when the pressure in the flasks becomes excessive. The flasks are shaken, occasionally, to assist absorption and to help coagulate the precipitates.

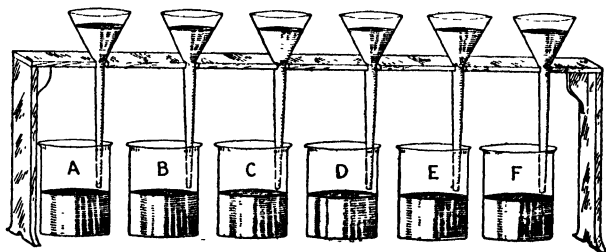

FIG. 2.—Filtration.

§ 5. Filtration.—The student should be familiar with folding of filter paper and fitting this snugly into the funnel. Moisten-

ing of the filter to make it adhere is necessary, but care should be exercised to prevent breaking of the paper. Long stem funnels are recommended for this work. A battery of six filters is shown in Fig. 2. The student should acquire experience in handling several samples at one time.

1. *Filtering by Suction.*—The suction flask attached to a filter pump is employed for rapid filtrations, an ordinary funnel with a hardened filter cone, or a cone of cheese cloth is used to prevent the filter paper from breaking. By a screw clamp control between the filter pump and the flask, the suction may be reduced to prevent breakage, that would occur even with these supports. See Fig. 3.

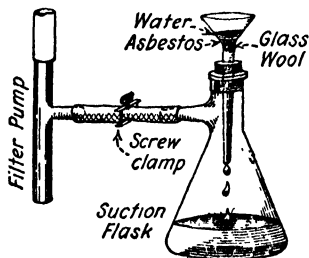

FIG. 3.—Filtering by Suction.

Filtration of corrosive liquids, strong acids or alkalis, will require the use of asbestos filters. A simple form may be made by placing a small wad of glass wool in the apex of the funnel, tamping it down and applying the suction. Asbestos suspended in water is poured over the wool to make a film 0.1 to 0.2 inch thick. If preferred a Gooch crucible may be used for holding the asbestos. This type of filter will be required in the separation of MnO_2 from iron, nickel and cobalt.

2. *Washing Precipitates.*—The following precautions must be observed:

(a) When filter papers are used the folds of the paper should be well creased to prevent the precipitate passing between the folds. The paper should fit the funnel snugly.

(b) The filter should not extend above the rim of the funnel.

(c) Wash out the greater amount of the mother liquor by using pure water in the first washings. If the filtrate is cloudy as it first comes through, pass this portion again through the filter.

Save only the first washing with the filtrate, rejecting additional washings, when filtrates are to be tested.

(d) To prevent cloudy filtrates, add the precipitating agent slowly to a hot solution. Allow to stand, stirring occasionally, until the "digestion" forms crystals which will not pass through the filter.

(e) Precipitates that persist in passing through the filter may often be prevented from doing so by adding to the wash water an ammonium salt, such as ammonium chloride or ammonium nitrate. The salt need not be washed out as it is volatile. The salts prevent formation of colloids.

(f) Test the filtrate to ascertain whether the precipitation has been complete. With experienced analysts this precaution is not necessary but advisable in H_2S precipitations.

(g) Gelatinous precipitates filter slowly and are difficult to wash free of impurities occluded by the precipitate. Filtration may be hastened by adding paper pulp to the solution containing the precipitate or by pouring a little paper pulp into the filter before adding the filtrate.

(h) Washing by decantation is generally to be recommended, as much as possible of the precipitate being retained in the beaker during the first three or four washings and the precipitate then transferred to the filter. This treatment is unnecessary for crystalline, easily filtered precipitates.

(i) Precipitates which absorb (occlude) substances should be redissolved and the precipitation repeated. This is especially necessary in separations where the substance, liable to be absorbed, is being determined.

(j) The beaker in which the precipitation was made should be "copped" out and all the material transferred to the filter, the beaker being left perfectly clean.

(k) To ascertain whether impurities have been washed out from the precipitate, precautions are generally given to test the wash water. For example, in washing barium sulfate free of the

excess of barium chloride reagent, in the determination of sulfur, tests are made for chlorine. This precaution is excellent advice for the beginner. It is never observed by the experienced chemist, as thoroughly tested methods for removal of impurities have made ample provision for removal of such impurities.

(l) A filter is best washed by starting with a stream of the wash water around the upper rim of the filter and following down in a spiral towards the precipitate in the apex, filling the filter $\frac{1}{2}$ to $\frac{2}{3}$ full at each washing.

(m) Washing the precipitate with hot water or when necessary with hot water and a volatile compound with an ion common to one of the precipitates may be advisable. For example, lead sulfate, PbSO_4 , is prevented from dissolving by adding sulfuric acid, H_2SO_4 , to the wash water. Likewise the precipitate potassium cobalt nitrite, $\text{K}_3\text{Co}(\text{NO}_2)_6$, is washed with a 10 per cent solution of potassium acetate, $\text{KC}_2\text{H}_3\text{O}_2$, containing potassium nitrite, KNO_2 ; and ammonium phosphomolybdate is washed with ammonium nitrate. Hot water is especially advisable in washing gelatinous precipitates such as ferric hydroxide, aluminum hydroxide, uranium hydroxide, etc. Addition of ammonium salts such as ammonium nitrate also prevents formation of colloidal solutions.

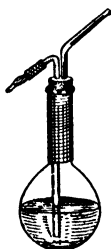

FIG. 4.—Wash Bottle.

(n) Occasionally it is necessary to wash the precipitate with a wash solution that has been saturated with the same compound.

§ 6. Testing for Acidity or Alkalinity.—Place a piece of litmus paper on a watch glass and moisten the paper. Now place a drop of the solution to be tested on the litmus paper. A red color indicates acids, a blue color an alkaline reaction.

§ 7. Cleaning of Apparatus.—The importance of using clean apparatus cannot be over-emphasized. The glassware should never be put away dirty. A few minutes should be given at the

close of the laboratory period to "cleaning up." The glass should be cleaned with chromic acid cleaning mixture, followed by tap water and then distilled water. Before putting it away it should be wiped dry with a clean towel, or tissue paper. Test tubes may be conveniently placed in a rack. Use a test tube brush for cleaning.

§ 8. Reagents.—The strength is indicated either by giving the specific gravity—(sp. gr. or d.) or by means of numerals; the first representing the volume of the concentrated reagent, and the second the volume of the diluting distilled water, i.e., HNO_3 1 : 3 is nitric acid diluted with three volumes of water per one volume of the strong acid, making a total of four volumes of the reagent. See reagents at close of text. For convenience the word percentage is used to represent the weight in grams of the reagent per 100 cc. of the solution. For example a 10 per cent NH_4Cl solution would be 10 grams of NH_4Cl in water diluted to 100 cc. In general the reagents are made of such concentration as to contain a definite amount of the principal element per cubic centimeter of the solution, usually 10 mg. per cubic centimeter.

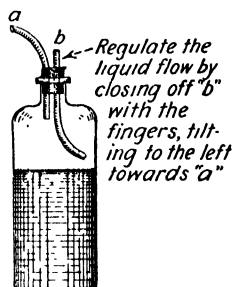

FIG. 5.—Reagent Bottle for Test Solutions.

PART I

THE METALS OR CATIONS

§ 9. The metals are the elements that form the positive cations of salts in solution. These substances are recognized by characteristic combinations with anions, or acid radicals, with a formation of either difficultly soluble compounds, or of colored ions or combinations.

The metals are classified under five divisions on account of their deportment towards certain group reagents, by formation of insoluble compounds. The groups are named after the precipitating reagents or the leading element of the group or sub-group, as follows:

1. *Hydrogen Chloride or Silver Group*.—Elements whose chlorides are difficultly soluble in water or dilute acid solutions.

Group Members.—Lead, Silver, Mercury (monovalent).

2. *Hydrogen Sulfide Group, Copper and Tin Divisions*.—Elements precipitated as sulfides from acid solutions by hydrogen sulfide.

Group Members:

Copper Division.—Mercury (divalent), Lead, Bismuth, Copper, Cadmium. Sulfides insoluble in ammonium polysulfide.

Tin Division.—Arsenic, Antimony, Tin. Sulfides soluble in ammonium polysulfide.

3. *Ammonium Sulfide Group, Iron and Aluminum Divisions*.—Elements whose sulfides are soluble in acid solutions, but are precipitated from neutral or alkaline solutions by hydrogen sulfide.

Group Members:

Iron Division.—Manganese, Iron, Cobalt, Nickel. Elements whose hydroxides are precipitated by strong alkali hydroxides.

Aluminum Division.—Aluminum, Chromium, Zinc. Elements forming soluble alkaline salts with strong alkali hydroxides.

4. *Ammonium Carbonate or Alkaline Earth Group.*—Elements that are not precipitated as sulfides by hydrogen sulfide, but are precipitated as carbonates in the presence of ammonium chloride in ammoniacal solutions by ammonium carbonate.

Group Members: Barium, Calcium, Strontium.

5. *Soluble Group, Magnesium and the Alkalies.*—Elements whose chlorides, sulfides, and carbonates are soluble under the conditions outlined above.

Group Members: Magnesium, Potassium, Sodium.

Grouping of Less Common Elements—Under Group 1.—W, Tl, Ta, Mo, Te. Group 2.—Rh, Pd, Os, Ru; Au, Pt, Ir, Mo, Te, Se. Group 3.—Gl, Ce, Nd, Pr, Er, La, Cb, Sc, Ta, Ti, Th, Yt, Yb, Zr; U, In, Ga, V. Group 4.—Ra. Group 5.—Li, Cs, Rb. A number of these elements fall in more than one group.

STUDY OF GROUP SEPARATIONS

§ 10. Test Solutions.—The test solutions throughout the experiments are prepared to contain 10 milligrams of the element per cubic centimeter. The tests are conducted with 5 cc. portions containing 50 milligrams of each element.

Apparatus.—The tests may be conducted in small beakers, or flasks or in large test tubes placed in a test tube rack.

Procedure.—1. Five elements, representative of the groups, will be tested—namely, silver, copper, iron, calcium and sodium. The test solutions are the nitrates of these elements. In starting the work label the apparatus with letters A, B, C, D and E and place on each the symbol of the element that it is to contain. Now continue as follows:

In "A" place 5 cc. of silver test solution, in "B" 5 cc. of copper solution, in "C" 5 cc. of iron solution, in "D" 5 cc. of calcium solution and in "E" 5 cc. of sodium solution. Dilute each with an equal volume of water (5 cc.) and add 2.5 cc. of strong HCl (d. 1.2). Observe that precipitation takes place in "A" alone. AgCl is formed. Write reaction of AgNO_3 with HCl.

2. Dilute "B," "C," "D," and "E" to 75 to 100 cc. If not already in marked flasks transfer the solutions to these. Connect the flasks in series as shown in Fig. 1, and attach one end to an H_2S generator. Pass in H_2S (use hood) for 4–5 minutes to displace the air in the flasks by H_2S and then close the exit tube and continue the passage of H_2S under slight pressure until the solutions are saturated; shaking, occasionally, the solutions to hasten absorption. Observe that precipitation takes place in B alone. CuS , black is formed. Write the reaction of $\text{Cu}(\text{NO}_3)_2$ with H_2S .

3. Neutralize the free acid in "C," "D," and "E," adding NH_4OH until the solution turns red litmus paper blue, when the

solution is shaken. Observe that a precipitate forms in "C" alone. The precipitate is FeS. Write the reaction of $\text{Fe}(\text{NO}_3)_3$ with H_2S .

4. Add HCl drop by drop to the solutions in "D" and "E" until these turn litmus paper red. Boil and filter off free sulfur. To the solutions add NH_4OH until the solution changes red litmus blue. Now add 4-5 cc. of $(\text{NH}_4)_2\text{CO}_3$ reagent. Observe that precipitation takes place in "D," while "E" remains clear. Write the reaction between $\text{Ca}(\text{NO}_3)_2$ and $(\text{NH}_4)_2\text{CO}_3$.

From the tests 1 to 4 inclusive, what conclusions do you draw as to a procedure for separating the five groups?

The following outline represents a survey of the tests you have made. The graphic Chart A, that follows the outline, will assist you in memorizing the procedures. Copy the outline and the graphic charts in your notebooks. In the charts the rectangles represent precipitates, the circles represent solutions. Show the colors of the precipitates and solutions by means of crayons.

OUTLINE A

Reagents	Silver	Copper	Iron	Calcium	Sodium
1. HCl	↓AgCl	Sol.	Sol.	Sol.	Sol.
2. H_2S		↓CuS	Sol.	Sol.	Sol.
3. $\text{H}_2\text{S} \cdot \text{NH}_4\text{OH}$			↓FeS	Sol.	Sol.
4. $(\text{NH}_4)_2\text{CO}_3$				↓CaCO ₃	Sol.
5. No group precipitant					Sol.

Following the preliminary tests, obtain an "UNKNOWN" from the instructor. Follow steps 1 to 4 inclusive, filtering each time a precipitate is obtained and testing the filtrate by the next step. Step 1, HCl; 2, H_2S ; 3, $(\text{NH}_4)_2\text{S}$; 4, $(\text{NH}_4)_2\text{CO}_3$; 5, evaporate to dryness, heat strongly (HOOD) and observe whether a residue remains.

CHART A

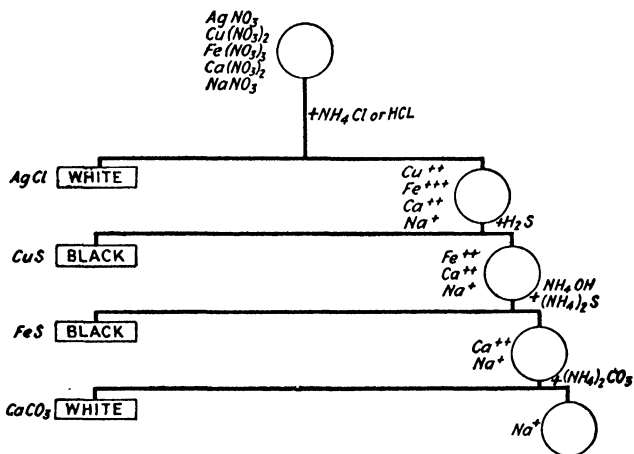

Separation of the Basic Groups.

HYDROGEN-CHLORIDE OR SILVER GROUP

Silver, Mercury (Hg^+), Lead

The members of this group are precipitated as chlorides in presence of chloride ions in water or dilute acid solutions.

PRELIMINARY TESTS

§ 11. In these preliminary tests a study will be made of characteristics of the members of this group, which enable their separation one from another. We will become familiar with tests that are used in the final identification of each element. Bismuth and antimony are included, as compounds of these undergo hydrolysis with formation of difficultly soluble salts, which precipitate with the silver group, if the solution is not sufficiently acid. 5 cc. portions of the test solutions are taken, since it is desirable to get a quantitative idea and the delicacy of the tests by working with definite quantities, 50 milligrams, in each case. The tests may be conducted in small beakers, or flasks or large bore test tubes.

A. Separations.—1. Label each container with the symbol of the element that is to be studied. If beakers are used label one Ag, another Pb, a third Hg, a fourth Bi and a fifth Sb. In the Ag beaker place 5 cc. of AgNO_3 test reagent, in the Pb beaker place 5 cc. of $\text{Pb}(\text{NO}_3)_2$ test reagent, in the Hg beaker place 5 cc. of HgNO_3 , in the Bi beaker, 5 cc. of $\text{Bi}(\text{NO}_3)_3$ and in the Sb beaker, 5 cc. of SbCl_3 . To each add 1 cc. of dilute (6N.) HCl reagent. Observe that precipitates form with Ag, Pb and Hg.

AgCl, white; PbCl_2 , white and HgCl, white.

Solubilities.—AgCl 0.00015* g. PbCl_2 0.91 g. HgCl 0.0002 g. per 100 cc. of water at 20° C.

* See note, p. 23.

2. Dilute each solution to about 20 cc., using distilled water. Pure water must always be used in the experiments. Observe that precipitates form in the Bi and Sb solutions. BiOCl, white; SbOCl, white.

Add to the bismuth and antimony precipitates concentrated HCl in just sufficient amount to dissolve the precipitates, observe the exact amount necessary and calculate the HCl added to prevent precipitation of BiOCl and of SbOCl.

Note.—The oxychlorides are formed, it is believed, in two stages as shown by the reactions:

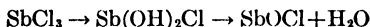
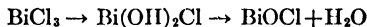

The addition of HCl furnishes H^+ ions, which repress the hydrolysis by reducing the ionization of water by the common ion effect of H^+ on $\text{H}^+ - \text{OH}^-$. Look up the law of molar concentration.

3. Heat to boiling the three solutions containing silver, lead and mercury. Do the precipitates dissolve? The solubility of PbCl_2 in hot water enables its separation from AgCl and HgCl. See the table of separations that follows the preliminary tests.

4. Allow the precipitates AgCl and HgCl to settle. Carefully pour off the clear solutions, leaving the precipitates in the beakers. This process is called *decantation*. Add a few cubic centimeters of NH_4OH reagent to each precipitate. Observe what happens. AgCl dissolves, forming the complex compound $\text{Ag}(\text{NH}_3)_2\text{Cl}$. HgCl turns black due to the formation of HgNH_2Cl and Hg° .

Reactions.— $\text{AgCl} + 2\text{NH}_3 = \text{Ag}(\text{NH}_3)_2^+ + \text{Cl}^-$ (in solution).

$2\text{HgCl} + 2\text{NH}_3 = \text{HgNH}_2\text{Cl} + \text{Hg}^\circ$ (a black precipitate) + NH_4Cl .

Draw your conclusions as to a method for separating AgCl and HgCl. Look at the table of separations that follows this preliminary exercise.

Notes.—In mixtures of AgCl and HgCl the test for silver will fail if much HgCl is present, due to the fact that the Hg metal that is formed by the action of NH₄OH reduces the silver salt with formation of metallic Ag°, which remains with the complex mercury compound. In this case it is necessary to dissolve the mixture with HNO₃ and HCl as stated in the table of separations. On dilution, AgCl remains as a white precipitate while the HgCl₂ passes into the solution.

B. Confirmatory Tests.—1. *Lead.*—Place 5 cc. of the Pb(NO₃)₂ test reagent in a beaker or a test tube containing 10–15 cc. of water. Add a few drops of dilute H₂SO₄. The white precipitate is PbSO₄.

Note.—The PbSO₄, washed free from H₂SO₄, is soluble in ammonium or sodium acetate solution. If a soluble chromate such as K₂CrO₄ or K₂Cr₂O₇ in solution is added to the acetate solution containing lead a yellow precipitate of PbCrO₄ is obtained. See the test for lead in the hydrogen sulfide group.

2. *Silver.*—Place 5 cc. of AgNO₃ test solution in a beaker containing 10–15 cc. of water. Add a few drops of dilute HCl reagent. The white precipitate of AgCl will form. Drop in a small piece of litmus paper and add NH₄OH until the paper turns blue. The AgCl will dissolve. Now add sufficient HNO₃ (or HCl) to turn the paper red. AgCl again precipitates. Study the test for confirming silver under the table of separations that follows.

3. *Mercury.*—Place 5 cc. of HgNO₃ in a beaker and add HCl to precipitate HgCl. Now add sufficient NH₄OH to form the black HgNH₂Cl+Hg.* This test is characteristic of mercury.

Note.—If the black compound obtained above is filtered off and transferred to a small beaker it can be dissolved in a few cubic centimeters of aqua regia. This solution evaporated to expel the excess of acid will leave a residue of HgCl₂, which is soluble in water. The addition of stannous chloride to this solution will precipitate HgCl due to reduction of Hg⁺⁺ to Hg⁺. A large excess of SnCl₂ reduces Hg⁺ to metallic Hg°.

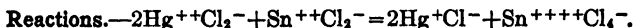

* See note, p. 23

4. *Separation of Silver, Lead and Mercury in Solution.*—Make a mixture of 5 cc. each of the test solutions of AgNO_3 , $\text{Pb}(\text{NO}_3)_2$ and HgNO_3 . Separate the three according to the directions given in the table of separations that follows.

5. *Examination of an Unknown.*—Obtain a solution containing one or more members of the HCl group from your instructor and examine this for the members of the group according to the table that follows.

§ 12

TABLE I

SEPARATION OF THE HYDROGEN-CHLORIDE OR SILVER GROUP

The material is brought into solution according to the directions for preparing solids for analysis as given in Part III, Systematic Analysis of a Substance. In solution the elements of this group are present as nitrates or sulfates.

1. Add to the solution HCl reagent (6N sol.) in sufficient amount to completely precipitate the members of the group. Ascertain this by shaking, allowing to settle and adding more reagent. To prevent the precipitation of BiOCl and SbOCl further acidify the solution by adding 5 cc. HCl (1:3). Filter, and wash the precipitate once with 2-3 cc. of the dilute HCl. Save the filtrate for detection of the subsequent group elements. Wash the residue with cold water containing a few drops of HCl, reject this washing. Examine the precipitate according to the procedure below.

Precipitate.— $PbCl_2$, Hg_2Cl_2 , $AgCl$, white.

Filtrate.—Subsequent groups. Save if these are to be tested.

2. *Isolation of Lead.*—Wash the residue into a large bore test tube or a small beaker, using hot water. Heat to boiling and filter. Wash the residue with a few cubic centimeters of boiling water. Test the filtrate for lead and the residue for mercury and silver.

Precipitate.— Hg_2Cl_2 , $AgCl$.

Filtrate.— $PbCl_2$.

4. *Separation and Detection of Mercury.*—Pour over the residue 10-15 cc. of dilute NH_4OH , passing the filtrate back over the precipitate several times. Finally wash with a few cubic centimeters of water. Save the filtrate for testing silver. A black precipitate is due to Mercury. (Silver may be present. If a negative test for silver is obtained, test this residue for silver.)

3. *Detection of Lead.*—Divide the solution in two portions: (a) Add to one portion dilute H_2SO_4 . A white precipitate is $PbSO_4$. (b) Add NH_4OH to the second portion of the solution until it colors red litmus paper blue. Now add 1 cc. of K_2CrO_4 or $K_2Cr_2O_7$. A yellow precipitate, insoluble in acetic acid is $PbCrO_4$.

Test solubility in acetic acid by adding this until the solution reddens litmus paper.

Residue.— $HgNH_2Cl$ + Hg . (Ag ?), black.

Filtrate.— $Ag(NH_3)_2Cl$.

5. *Confirmation of Mercury.*—Dissolve the precipitate in a small pyrex beaker with a few cubic centimeters of aqua regia. Dilute with a little water, and if the solution is cloudy silver is indicated. Filter, saving the precipitate for the silver test if 6 is negative.

6. *Test for Silver.*—Add dilute HNO_3 until the solution is acid, reddening blue litmus paper. If silver is present a white precipitate will be obtained, $AgCl$.

Evaporate the filtrate to pastiness. Take up with a little water and add $SnCl_2$ solution, drop by drop. A gray precipitate proves the presence of mercury. $HgCl_2 \cdot Hg$ is formed.

Should the test be negative examine the mercury residue for silver as indicated under 5.

(If test 6 is negative for silver, dissolve the residue on the filter in a few drops of NH_4OH and acidify. $AgCl$ will precipitate, in presence of silver.)

CHART I

HYDROGEN-CHLORIDE OR SILVER GROUP

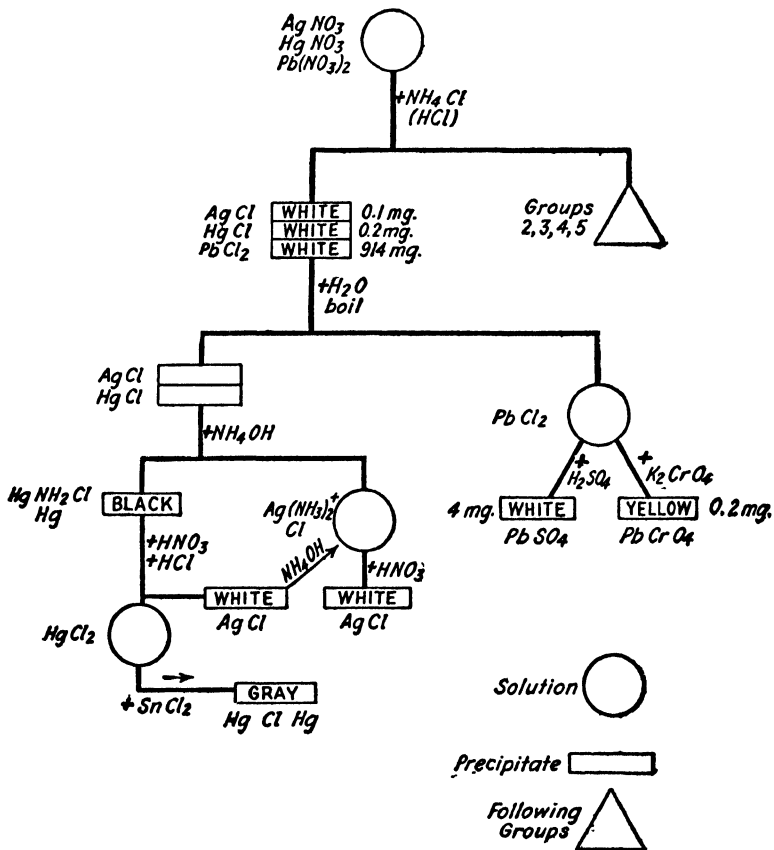

Colors of precipitates are indicated.

The figures represent milligrams of the salt soluble in 100 cc. of water. Under above conditions the solubility is less than the figures indicate due to repression of ionization by the common ion effect by the reagents.

SUMMARY AND CHEMICAL PRINCIPLES—HYDROGEN-CHLORIDE OR SILVER GROUP

§ 13. The chlorides of lead, silver and mercury have a comparatively small solubility in cold acid solutions, while the other common elements are readily soluble. This fact makes it possible to separate these three elements from the others by converting them to chlorides. Since the nitrates of these three are soluble in water, solution is effected by converting them to this form and then precipitating them by addition of chloride ions. Hydrochloric acid is commonly used for this group precipitation. To prevent precipitation of bismuth and antimony a certain excess of the acid is added and the precipitate washed with an acid solution to dissolve the oxychlorides BiOCl and SbOCl , should these be present.

1. *Lead*.—The chloride of lead, although but slightly soluble in the presence of HCl , is more readily soluble in pure water. The chloride is easily soluble in hot water, a fact used in separating lead from silver and mercury. A glance at Chart I shows that the solubility of PbCl_2 in 100 cc. of water at 18°C . is about 0.9 gram, while at 100°C . it is almost four times this amount.

If to the solution chloride ions are added, the solubility of PbCl_2 is greatly decreased due to the "common ion effect." It will be recalled that the solubility product of an ionized compound is a constant (see page 40), so that increasing the anion concentration will decrease the cation concentration. For example, in a hypothetical salt MA in solution, where M represents ionized cations and A ionized anions, an addition of A ions would decrease the M -ion concentration. If M and A were each represented by the figure 10, $\text{MA} = K$ would become $10 \times 10 = 100$, an increase of the ion concentration of A to 20 would result in a decrease of

the M-ion concentration to 5 in order that the product of the ion concentration of M and A would remain the constant 100; the removal of M ions would be accomplished by formation of unionized MA molecules and the precipitation of the compound MA. Provided no complex ion were formed, an increased concentration of either M or A by addition of a reagent containing M or A, a common ion, would decrease the solubility of the precipitate MA. This action is in accord with a famous chemical principle defined by *Le Chatelier*. "*If a system at equilibrium is subjected to any stress, a change which reduces the stress will occur.*"

PbCl₂ should be removed from AgCl and HgCl by washing with hot water. If the solution containing PbCl₂ is concentrated and cooled the PbCl₂ will precipitate in the form of needle-like crystals. It is simpler, however, to add a little dilute H₂SO₄ to form the less soluble salt, PbSO₄ (solubility 0.0042 g. per 100 cc.) which is less than $\frac{1}{240}$ of the solubility of PbCl₂. If preferred, lead may be confirmed by neutralizing the free acid with NH₄OH and making acid with acetic acid and adding a soluble chromate salt such as K₂CrO₄ which causes the precipitation of yellow PbCrO₄.

On account of the solubility of PbCl₂ it is tested for also in the following group and will be taken up later in the discussion on that group.

2. *Silver*.—The solubility of the chloride of silver is exceedingly small, 100 cc. of water dissolves only 0.00015 g. at 18° C. The presence of Cl ions by addition of HCl decreases this solubility. (Common ion effect. See note on page 23.)

The separation of silver from mercury is accomplished by the addition of NH₄OH by the action of NH₃ in the formation of the complex ion Ag(NH₃)₂⁺. This results in the removal of Ag⁺ ions from the solution, disturbing the equilibrium. To restore this, some AgCl ionizes and some of the precipitate AgCl dissolves. (*Le Chatelier's* principles.) This is shown as follows:

AgCl precipitate \rightarrow AgCl in solution \rightarrow Ag⁺ Cl⁻ ions equilibrium.

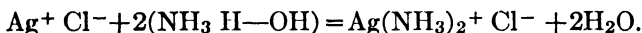

By addition of an acid with an increase of H⁺ ions NH₄⁺ is formed and AgCl reprecipitated. This is a confirmatory test for silver. White AgCl changes to violet, then brown, and finally to black upon exposure to strong light; this occurs rapidly in direct sunlight. This compound is soluble in concentrated HCl, in solutions of Na₂S₂O₃ (hypo), NaCN, KCN, and Hg(NO₃)₂.

3. *Mercury*.—It is interesting to note that mercury in its monovalent form is insoluble as a chloride and in the divalent form is soluble. Confirmatory tests for mercury take advantage of this principle. The non-poisonous calomel, HgCl, is insoluble and the corrosive sublimate, HgCl₂, is soluble. The solubility of HgCl in 100 cc. of water is 0.0002 g. while HgCl₂ is 20 thousand times as soluble, the solubility greatly increasing at higher temperatures.

When NH₄OH is added to HgCl, ammono-basic mercuric chloride, HgNH₂Cl, and metallic mercury are formed. It is thought that an interchange of electrons between Hg⁺ ions takes place; the ion, taking up an electron, becomes a metallic atom Hg⁰, while the ion giving up the electron is oxidized to Hg⁺⁺. This occurs in the presence of ammonia. The formation of the black substance is characteristic of the action of NH₄OH on mercurous chloride, and a further confirmation is generally not required.

If the compound is dissolved in aqua regia it is converted to HgCl₂. The HNO₃ is expelled by evaporation, the HgCl₂ dissolved in water, and the HgCl₂ converted to HgCl by the action of SnCl₂, a strong reducing agent. The reactions are given in the preliminary tests.

Mercury is easily displaced from its solution by metals such as Zn⁰, Fe⁰, Cu⁰, the metal Hg⁰ depositing on the surface of the added metal.

The black precipitate, $\text{HgNH}_2\text{Cl} + \text{Hg}^*$, will carry down silver, and if the quantity of this is small a negative test will be obtained. Should a negative test for silver be obtained, it is advisable to carry out the confirmatory test for mercury by dissolving it in aqua regia. Upon dilution AgCl precipitates, HgCl_2 is in solution. The solution filtered leaves AgCl on the filter. It may be confirmed by dissolving in NH_4OH and reprecipitating by adding an acid, HNO_3 or HCl .

In the list that follows, the elements are arranged in the order of their relative tendency to form ions, the more active preceding the less active. Zinc for example has a greater tendency to form ions than hydrogen, so that Zn^0 placed in a solution of HCl displaces 2H^+ forming H_2 and in turn becomes an ion Zn^{++} .

Displacement (Electromotive or Potential) Series.

K, Na, Ba, Sr, Ca, Mg, Al, Mn, Zn, Cd, Fe, Tl, Co, Ni, Sn, Pb, —H—As, Cu, Bi, Sb, Hg, Ag, Pd, Pt, Au, F, Cl, Br, I, O.

Explain what would take place if metallic iron were placed in a solution containing CuSO_4 .

Note. A high concentration of chloride ions will result in the formation of complex ions causing an increased solubility of AgCl .

* It is thought by some that the compound is a mercurous salt rather than a mixture.

**CLASSROOM REVIEW OF THE HYDROGEN-CHLORIDE
OR SILVER GROUP**

§ 14. The following topics are offered as a suggestion for a review of the reactions and chemical principles involved in the examination of this group.

1. What are the compounds formed in the process of separation of the members of the group? Write equations representing the reactions.
2. Law of Molar Concentration or Mass Action. Define and explain.
3. Common Ion Effect. What is the meaning? Explain.
4. Solubility of lead chloride. The original precipitate and the crystals later obtained by cooling a hot water solution do not appear the same. Is there any reason for this?
5. Solubility of silver chloride in ammonia. Why does the AgCl dissolve? What chemical principles are involved? What is meant by the term "solubility product"?
6. Formation of the black precipitate of mercury by the action of ammonia. Why is the precipitate black? How can you account for the oxidized and the reduced mercury in the same mixture? Silver may be occluded in this residue as metallic silver. Why is silver reduced? Explain by the action of metallic mercury on AgCl.
7. Complete and balance the following equations in your note books:

Group Reactions

- (a) $\text{Pb}(\text{NO}_3)_2 + \text{NH}_4\text{Cl} = \text{PbCl}_2 +$
- (b) $\text{PbCl}_2 + \text{H}_2\text{SO}_4 = \text{PbSO}_4 +$
- (c) $\text{Pb}(\text{C}_2\text{H}_3\text{O}_2)_2 + \text{K}_2\text{CrO}_4 = \text{PbCrO}_4 +$
- (d) $\text{HgNO}_3 + \text{NH}_4\text{Cl} = \text{HgCl} +$
- (e) $\text{HgCl} + \text{NH}_4\text{OH} = \text{HgNH}_2\text{ClHg} +$
- (f) $\text{HgCl} + \text{Cl}_2$ (Aqua regia) $= \text{HgCl}_2 +$
- (g) $\text{HgCl}_2 + \text{SnCl}_2 = \text{HgCl} +$
- (h) $\text{AgNO}_3 + \text{NH}_4\text{Cl} = \text{AgCl} +$
- (i) $\text{AgCl} + \text{NH}_4\text{OH} = \text{Ag}(\text{NH}_3)_2\text{Cl} +$
- (j) $\text{Ag}(\text{NH}_3)_2\text{Cl} + \text{HNO}_3 = \text{AgCl} +$
- (k) $\text{Ag} + \text{HNO}_3 = \text{AgNO}_3 +$

HYDROGEN-SULFIDE GROUP

- A. Mercury (Hg^{++}), Lead, Bismuth, Copper, Cadmium (Copper Division)**
B. Arsenic, Antimony, Tin (Tin Division)

The members of this group are precipitated, as sulfides; from solutions containing their ions, by H_2S ; the precipitation taking place in dilute acid solutions of sufficient hydrogen ion concentration to prevent precipitation of the ammonium sulfide group.

PRELIMINARY TESTS

I. INSOLUBLE H_2S SUB-GROUP, COPPER DIVISION

§ 15. The sulfides of this subdivision A are practically insoluble in yellow ammonium sulfide, while those of division B are soluble.

Conduct the beginning tests in small Erlenmeyer flasks, each flask containing a different test solution. Label the flask with the symbol of the element that it is to contain, the first flask Hg, the second Pb, the third Bi, the fourth Cu, the fifth Cd and the sixth Sb. The last flask contains a member of the soluble Tin division. Antimony is included to show why we divide the H_2S group into two divisions.

A. Separations.—1. Place in each flask 5 cc. of its special test solution, in the Hg flask 5 cc. of HgCl_2 , in the Pb flask 5 cc. of $\text{Pb}(\text{NO}_3)_2$, in the Bi flask 5 cc. of $\text{Bi}(\text{NO}_3)_3$, in the Cu flask 5 cc. of $\text{Cu}(\text{NO}_3)_2$, in the Cd flask 5 cc. of $\text{Cd}(\text{NO}_3)_2$ and in the Sb flask 5 cc. of SbCl_3 . Each flask will contain 50 milligrams of the element in question. Add to each solution 2.5 cc. of concentrated HCl (d. 1.2) and dilute to 100 cc. Connect the flasks in series as is shown in Fig. 1, and attach to the H_2S generator as shown. Pass in H_2S (HOOD) until the exit tube emits H_2S , as is shown by

the gas blackening moist lead acetate paper. Now close the tube by means of a pinch cock or a rubber tip of a "policeman," and pass in H_2S under slight pressure until all the solutions are saturated. The stop cock of the acid reservoir of the generator should be left open so that the acid has a free passage to relieve pressure when this becomes necessary. Shake the flasks occasionally to insure thorough contact of the H_2S with the solutions. Observe any change of color that occurs and the colors of the precipitates that form. The compounds and their relative solubilities are given in the table on page 38. The figures are only approximate, giving comparative solubilities. These solubilities are for water only, but are useful for purpose of comparison.

2. *Separation of Antimony*.—(Representative of the Tin group). Allow the precipitates to settle and decant off the supernatant solutions rejecting these and saving the precipitates. Transfer each precipitate to a separate filter and allow to drain.

Note.—It is well to arrange the filters in a row, placing the corresponding flasks in front to identify the precipitates.

Pour over the Sb_2S_3 precipitate 5–10 cc. of yellow ammonium sulfide reagent and observe that the precipitate dissolves. Try the same test with the Bi_2S_3 precipitate and observe that it remains insoluble. HgS , CuS , PbS and CdS are insoluble in $(NH_4)_2S_x$. Reject the antimony solution. Wash out the excess of the sulfide reagent from the Bi_2S_3 .

3. *Separation of Mercury*.—Transfer each precipitate to its individual flask by placing each funnel with the paper and precipitate over the flask, punching a hole in the apex of the paper and washing down the precipitate with a few cubic centimeters of water into the flask. To each add approximately $\frac{1}{2}$ of its volume of concentrated HNO_3 (d. 1.42), that is to say, in case the precipitate and water is approximately 10 cc. add 2 cc. of HNO_3 . Heat each solution to boiling and observe that all the precipitates dissolve except the HgS . What does this suggest as to a method

for the separation of HgS from the other sulfides of this sub-group? For confirmation of mercury see subject under the confirmatory tests that follow later.

Reactions.—(a) HgS remains unchanged.

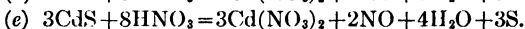
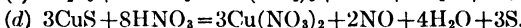
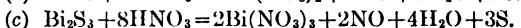
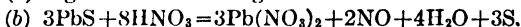

4. *Separation of Lead.*—To each solution add a few cubic centimeters of dilute H₂SO₄. Observe that precipitation occurs with lead alone, PbSO₄ being formed.

Note.—Since the PbSO₄ is slightly soluble in dilute HNO₃ it is the general practice to expel the HNO₃ by evaporating to dryness before the H₂SO₄ is added. This evaporation must be carried on in the general separation as will be seen later. We omit it here to save time.

Filter off the PbSO₄ and test further as directed under confirmatory tests given later, if desired. The test will be repeated later.

5. *Separation of Bismuth.*—To each of the three remaining solutions containing the Bi, Cu and Cd ions add NH₄OH until the solutions become alkaline and color red litmus paper blue. Observe that precipitation occurs in the bismuth flask, a blue precipitate forms in the copper flask, but this dissolves with additional NH₄OH. A white compound forms in the cadmium flask but this also dissolves with addition of more NH₄OH. The reactions follow:

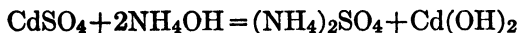
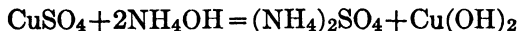

Note.—Boiling is avoided since this would reprecipitate $\text{Cd}(\text{OH})_2$, causing it to come down with BiOOH .

The confirmatory test for bismuth is given later.

6. Copper and Cadmium still remain in solution. The copper solution is an intense blue while that of cadmium is colorless. This would distinguish copper from cadmium, unless the amount of copper were so small that the color of the ions would not show. In this case a special test would be necessary. See confirmatory test for cadmium below.

B. Confirmatory Tests.—These tests will be made in the separation and detection of members of the Copper group so that it is not necessary to carry out these in this preliminary work. We include these here for study and reference.

1. *Mercury.*—If the HgS is dissolved in aqua regia, the solution evaporated to dryness to expel the free acid and the HgCl_2 dissolved in water, the addition of SnCl_2 solution will give a gray to dark gray precipitate of HgCl (with some Hg if SnCl_2 was added in excess). Consult reactions given for mercury in the Hydrogen-Chloride group.

2. *Lead.*—The PbSO_4 obtained in the separation 4 above (Solubility of PbSO_4 in 100 cc. water is 0.0042 g. at 20°), is dissolved in a solution of ammonium acetate, and lead precipitated as yellow PbCrO_4 by the addition of a soluble chromate, $\text{K}_2\text{Cr}_2\text{O}_7$ or K_2CrO_4 . The acetate extraction effects a separation from BaSO_4 which may be mistaken for PbSO_4 . The test is generally made in an acetate solution to which a few drops of acetic acid have been added, this acid preventing the precipitation of $(\text{BiO})_2\text{CrO}_4$, which might be present as a contaminant, while PbCrO_4 precipitates.

3. *Bismuth.*—To confirm bismuth the NH_4OH precipitate obtained in 5 is dissolved in a few drops of HCl . If this solution is diluted largely with water a precipitate will be obtained due to the hydrolysis of bismuth with formation of BiOCl . If this precipitate is filtered off, and freshly prepared sodium stannite*

* Sodium stannite, p. 145.

added, a dark colored residue of metallic Bi will remain on the filter. The reaction is shown below.

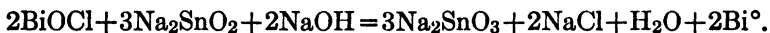

4. *Copper*.—If the blue color of the ammonium cupric ion is not evident (Ni also gives a blue color) the presence of copper may be detected by acidifying the solution with acetic acid (litmus paper test) and adding 2–3 cc. of potassium ferrocyanide. A pink colored precipitate of $\text{Cu}_2\text{Fe}(\text{CN})_6$, best seen by filtering onto a filter paper, is obtained if copper is present. The precipitate obtained with cadmium is white, that of nickel is green.

5. *Cadmium*.—To confirm cadmium the solution containing Cu and Cd is made acid with dilute H_2SO_4 , adding the acid until the solution colors litmus paper red. About 0.5 cc. of iron powder is added. This precipitates the copper as metallic Cu° but does not precipitate Cd° . Look up the table showing the displacement series of the elements and explain.

CdS , yellow, may now be precipitated from this solution filtered from the iron and copper. Lead must be absent as well as other elements that would precipitate and mask the yellow color of CdS .

An optional method is to add a solution of KCN in sufficient amount to destroy the blue color due to copper and then saturate the solution with H_2S . CdS precipitates in presence of KCN, CuS does not. KCN is POISON, so handle with care.

C. *General Separation*.—If time permits it is a good practice to take 5 cc. portions of the test solutions and make a composite. Using this known solution, separate and confirm the elements according to directions that follow in the table of separations. The chart will be found useful as a brief summary of the steps in the procedure.

The Unknown.—Obtain an unknown solution containing one or more of the members of the H_2S group from your instructor and examine this according to the directions that follow.

II. SOLUBLE H₂S SUB-GROUP, THE TIN DIVISION

Arsenic, antimony and tin are precipitated from acid solutions by H₂S as sulfides which are soluble in ammonium polysulfide.

PRELIMINARY TESTS

§ 16. A. *Separations*.—1. Label six small flasks, each with a designating symbol, the first with As⁵, the second with As³, the third with Sb⁵, the fourth with Sb³, the fifth with Sn⁴ and the sixth with Sn². Place in each 5 cc. of its corresponding test solution containing respectively 50 mg. of arsenic, or of antimony, or of tin as chlorides, the valence being indicated by the numeral above the symbol. Use the test solutions AsCl₅, AsCl₃, SbCl₅, SbCl₃, SnCl₄, SnCl₂. The object is to study each element with reference to its isolation and identification with consideration of the valences in which the element is commonly found combined.

Add to each solution 2.5 cc. of concentrated HCl (d. 1.2) and dilute to 100 cc. with water. Connect the six flasks in series to an H₂S generator (HOOD) and saturate with H₂S. Observe the color of the precipitates formed, and the rate at which these form. Heat the solution containing AsCl₅ and note that precipitation is assisted by heating.

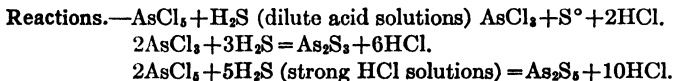

The other compounds formed are Sb₂S₅, Sb₂S₃, SnS₂, SnS. Write the reactions.

2. *Action of Ammonium Polysulfide*.—Filter each sulfide onto a separate filter. Wash once with a few cubic centimeters of water, rejecting the washing. Now pour over each precipitate 5–10 cc. of strong solution of (NH₄)₂S_x. All the precipitates dissolve. Both the sulfides of arsenic form (NH₄)₃AsS₄, both the

sulfides of antimony form $(\text{NH}_4)_3\text{SbS}_4$, both of the sulfides of tin form $(\text{NH}_4)_2\text{SnS}_3$. This is due to the fact that oxidation takes place of the arsenous, antimonous and stannous sulfides to the higher forms due to the action of S° in the polysulfide. $\text{M}^{++} + \text{S}^\circ = \text{M}^{++++} + \text{S}^-$ (M a divalent ion oxidized).

3. Combine the two arsenic solutions, the two antimony solutions and the two tin solutions. Continue with the three solutions as follows: Dilute each to three times their respective volumes. Drop in a piece of litmus paper and add dilute HCl until a precipitate forms and the litmus paper is colored red. A white precipitate of free S is first formed and then the colored sulfides of the elements in question as the solution becomes acid. To recognize the difference between the free S and the sulfides make a blank test with a little ammonium polysulfide, adding HCl to acid reaction. Note the colors of the precipitates As_2S_5 , Sb_2S_5 , SnS_2 .

The reaction of HCl on the arsenic compound is as follows:

$2(\text{NH}_4)_3\text{AsS}_4 + 6\text{HCl} = \text{As}_2\text{S}_5 + 3\text{H}_2\text{S} + 6\text{NH}_4\text{Cl}$. (The free S° liberated is due to the HCl action on the excess of the polysulfide reagent). Write the reactions of HCl on $(\text{NH}_4)_3\text{SbS}_4$ and $(\text{NH}_4)_2\text{SnS}_3$.

Filter off the sulfides through reinforced filtrates. See *Note*.*

4. *Solubility of the Sulfides and Separation of As_2S_5* .—Wash out the excess of the polysulfide reagent with hot water and by means of suction drain off the water, leaving comparatively dry precipitates.

**Note*.—Filter papers may be reinforced by making a filter cone of cheese cloth, folding the cloth just as you do a filter paper. Place the cone in the funnel and then place within this cone the regular paper filter. The funnel stem is inserted in a rubber stopper and fitted to a suction flask. The rubber connection of the flask to the suction (vacuum) pump should have a screw clamp, so that the pressure can be reduced, otherwise the papers will break regardless of the reinforcement with the cheese cloth.

By means of a glass rod flattened at one end transfer the greater portion of each precipitate to its own respective test tube, rejecting the filters with the small amount of adhering precipitates. Be careful not to contaminate the precipitates with each other. (Clean the transferring rod each time it is used.) Add to each precipitate in its test tube 10 cc. of concentrated HCl (1.2 sp. gr.). Place the tubes in a beaker of boiling hot water for ten minutes. Shake to effect better contact of the precipitate with the acid. Observe that As_2S_5 remains insoluble, while Sb_2S_5 and SnS_2 dissolve. What does this show as to a method for separating arsenic from antimony and tin? See procedure for further identification of arsenic as given under confirmatory tests.

5. *Separation of Antimony from Tin.*—Add 15 cc. of water to the antimony and to the tin solutions and saturate with H_2S . Observe that precipitation of antimony sulfide takes place, while tin remains in solution. Dilute further until the volume of each is 50 cc. Does the tin sulfide precipitate? What does this suggest as to a method for separating antimony from tin? The precipitate of antimony is Sb_2S_3 .

Note.—The action of HCl on Sb_2S_3 with liberation of H_2S causes a reduction of Sb with formation of SbCl_3 . See Chart IIB.

6. Dilute the tin solution until a precipitate forms. Estimate the dilution necessary for a solution containing 10 cc. of concentrated HCl to enable the precipitation of SnS_2 from the results of your experiment.

B. Confirmatory Tests.—Since practice in confirming the elements of this sub-group will be obtained in the separations the data that follows are given for reference and study.

1. *Arsenic.*—Arsenic sulfide may be dissolved in concentrated HNO_3 (d. 1.4). To further identify arsenic this nitric acid solution is evaporated to dryness (hood). The residue is dissolved in 2 cc. of water and 2 cc. of NH_4OH (d. 0.9) added, and the solution filtered into a small test tube. Ten cc. of ammonium mag-

nesium nitrate reagent are added. $MgNH_4AsO_4$, white, will precipitate in presence of arsenic.

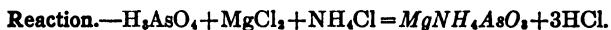

Further identification of arsenic may be made to distinguish the white precipitate obtained in the above test from $Mg(OH)_2$ and $Al(OH)_3$. The precipitate is filtered off, washed with a few drops of water, and 2 cc. of $AgNO_3$ reagent containing 4–5 drops of acetic acid are added. In presence of arsenic a dark red residue remains on the filter paper, Ag_3AsO_4 being formed.

Note.—The acetic acid in the silver reagent is added to dissolve the compounds mentioned above. $Mg(OH)_2$ and $Al(OH)_3$ would go into solution leaving no residues, while the arsenic compound would decompose with formation of the red Ag_3AsO_4 .

2. *Antimony.*—The sulfide of antimony is dissolved in concentrated HCl and H_2S expelled by warming. This solution is diluted with 15–25 cc. of water and filtered. The filtrate is examined for antimony as follows: A piece of tin foil is placed in the solution. In presence of antimony a black coating will form on the tin foil. Explain, looking up the displacement series of the elements. The foil is removed and washed with water. If the stain is due to antimony it will not dissolve in a solution of $NaOCl$ or $NaOBr$. If the stain is due to As it will dissolve in these reagents. Platinum foil in contact with the tin hastens reduction of antimony.

3. *Tin.*—The solution, containing the tin and free HCl, is boiled to expel H_2S , should this be present in the solution, and is treated as follows: A small piece of aluminum foil, or an iron nail is placed in the solution and the solution boiled gently. Stannic tin is reduced to stannous condition. If this reduced solution is filtered into a test tube containing $HgCl_2$ solution a gray precipitate ($HgCl$) will be obtained. Compare this with the $SnCl_2$ test for mercury. Consult the reactions given in the HCl group.

Distinguishing Antimony from Arsenic.—Both elements form hydrides by the action of nascent H on their solutions, SbH_3 and AsH_3 . Stibine and arsine burn in the air. If a cold surface is held in the flames, for example, a cold porcelain evaporating dish, black stains will be deposited. The arsenic stain is soluble in a solution of NaOCl or NaOBr , the antimony stain is not.

If arsine is passed into a solution of AgNO_3 it reduces the salt to metallic silver, stibine forms the black silver antimonoid.

If the arsenic and antimony stains obtained in the AsH_3 and SbH_3 tests above are dissolved in a drop of HNO_3 , the free acid expelled by warming, and a drop of AgNO_3 reagent placed on each residue, a red stain is obtained with arsenic and no stain with antimony.

Consult "Standard Methods of Chemical Analysis" by the author for additional tests for arsenic and antimony, notably the Gutzeit tests, and the Marsh tests.

Distinguishing Stannous from Stannic Tin. State of Oxidation.—Stannous tin produces a gray precipitate when its solution is added to a mercuric chloride solution. Stannic tin does not give this precipitate. It is evident that mercurous and mercuric compounds may be distinguished with SnCl_2 reaction.

C. Separations.—Make a composite solution with 5 cc. portions of AsCl_3 , SbCl_3 and SnCl_4 solutions. Separate and identify the elements according to the directions given in the table of separations that follows.

Unknown.—Get a sample of an unknown containing one or more of the elements of the Tin group and examine this according to directions given in the table of separations that follows.

§ 17

TABLE II-A
SEPARATION OF THE HYDROGEN-SULFIDE GROUP

1. *Solids*.—Dissolve and prepare according to directions under the systematic analysis of substances in the latter portion of this text. *Liquids*.—If the solution is an unknown, proceed according to Table I and then continue with the filtrate from the HCl group according to 2 below.

If the solution is the filtrate from HCl group, continue according to 2.

2. The acidity of the solution should be approximately 0.3 N. If HNO₃ is present evaporate to dryness, add 2.5 cc. of strong HCl (d. 1.2) and dilute to 100 cc. If bismuth or antimony is present a precipitate is apt to form, but does no harm.

Saturate the solution with H₂S, preferably in a flask under pressure. (If AsCl₅ is present, precipitation is best accomplished by heating the solution.) After 10 minutes add 50 cc. of water and again pass in H₂S for 5 to 10 minutes. Filter, and test the filtrate with more H₂S to be sure that precipitation is complete. If a precipitate forms, again filter onto the original precipitate. The precipitate is the H₂S group. The filtrate contains the following groups, if these were present in the sample.

Precipitate. — <i>HgS, PbS, Bi₂S₃, CuS, CdS, As₂S₃, As₂S₅, Sb₂S₃, Sb₂S₅, SnS, SnS₂.</i>	Filtrate. —Save if later groups are to be tested, otherwise reject.
---	--

Note the color changes that take place during precipitation. Consult the preliminary tests.

Wash the precipitate with water containing H₂S, using 25–50 cc. of water. Reject the washings.

3. Separation of the H₂S Sub-groups—Copper and Tin Divisions A and B.

Pour 5 to 10 cc. of ammonium polysulfide reagent over the precipitate, pouring the filtrate back over the precipitate three or four times. Wash the residue with 25 to 50 cc. of water, combining the washings with the (NH₄)₂S_x extract.

Note.—Omit step 3 if As, Sb and Sn are known to be absent.

Residue. — <i>HgS, PbS, Bi₂S₃, CuS, CdS.</i> The residue may be transferred by means of a glass or porcelain spatula to a pyrex beaker or a large bore test tube, discarding the filter with its small amount of adhering precipitate. Should no residue remain from the (NH ₄) ₂ S _x extraction the copper sub-group is absent. In this case continue according to Table III. If a precipitate is obtained continue according to step 4.	Filtrate. —(NH ₄) ₃ AsS ₄ , (NH ₄) ₃ SbS ₄ , (NH ₄) ₂ SnS ₃ , (Hg, Cu as impurities). Save for tests given under Table IIB.
---	---

Notes.—A preliminary test to ascertain whether the tin group is present may be made on a small portion of the polysulfide extract by acidifying. A white precipitate indicates absence of the tin group, a yellow precipitate indicates its presence in the extract.

CuS and HgS are slightly soluble in the polysulfide. If the precipitate of the tin group is dark colored Hg and Cu may be expected. Extraction with (NH₄)₂S_x is complete when a fresh portion of the reagent passed through the precipitate, and diluted with a little water and then made acid (blue litmus turns red) will give only a white precipitate.

TABLE IIA—Continued

4. *Separation of the H₂S Sub-group, Copper Division—Isolation of Mercury.*—Add to the precipitate, transferred to a small pyrex beaker, 10–15 cc. dilute HNO₃ (1 part strong acid to 3 water, i.e., 1 : 3 or 3N). Heat gently to boiling and filter off the insoluble residue (HgS), saving both residue and filtrate. Wash the residue with a few cubic centimeters of hot water. (Reject this washing, but save the filtrate.)

Residue.—HgS, black. (PbSO₄ may be present, also free S.)

Filtrate.—Nitrates of Pb, Bi, Cu, Cd. Examine according to 6 below.

5. *Confirmation of Mercury.*—By means of a spatula transfer the residue to a small pyrex beaker. Add 4–5 cc. of strong HCl and 2 cc. of strong HNO₃. Evaporate to a moist residue. Take up with a little water and boil. (Usually a globule of sulfur remains, but does no harm.) Add drop by drop SnCl₂ reagent. A gray precipitate, darkening on addition of SnCl₂ in excess, proves the presence of mercury.

Note.—The tin reagent should contain a piece of tin foil to keep it in stannous condition.

6. *Isolation of Lead.*—To the filtrate of step 4 above add 2–5 cc. of dilute H₂SO₄ (1 : 3). A cloudiness indicates PbSO₄. Evaporate rapidly to small volume. Place on a hot plate (hood) and take to strong fumes, to expel free and combined HNO₃. Cool and add about 10 cc. of water. Filter and wash with a few cubic centimeters of water. Save the precipitate and filtrate.

Precipitate.—PbSO₄, white.

Filtrate.—Sulfates of Bi, Cu, Cd. Test according to 7 below.

Confirmation of Lead.—Transfer the precipitate by means of a spatula to a small beaker. Pour over the PbSO₄ 10–15 cc. of 30 per cent ammonium acetate reagent and warm gently. (If preferred the acetate may be poured repeatedly over the PbSO₄ in the filter.) Drop in a small piece of litmus paper and add cautiously dilute acetic acid until the paper shows an acid reaction. Add to the solution a few cubic centimeters of K₂CrO₄ or K₂Cr₂O₇ reagent. A yellow precipitate of PbCrO₄ proves the presence of Lead.

7. *Isolation of Bismuth.*—To the filtrate from lead (step 6) add NH₄OH until the solution turns red litmus paper blue. A whitish precipitate indicates Bi(OH)₃, or Cd(OH)₂; a light blue precipitate indicates copper, Cu(OH)₂. Add more NH₄OH to dissolve Cd(OH)₂ and Cu(OH)₂. Bi(OH)₃ remains insoluble. Filter and wash the precipitate, keeping both precipitate and filtrate for tests that follow.

Precipitate.—BiO(OH), white, gelatinous.

Filtrate.—Cu(NH₃)₄ (blue), Cd(NH₃)₄ (colorless). Test according to 8 below.

Confirmation of Bismuth.—If the precipitate is large transfer from the filter to a watch glass and dissolve with a few drops of dilute HCl (1 : 5). If the precipitate is small, dissolve on the filter with a few drops of dilute HCl. Dilute the solution to 50–100 cc. with water. A white precipitate, BiOCl, further confirms Bismuth. See sodium stannite test, Preliminary Test B 3, p. 28.

8. Divide the solution in two portions. *A. Confirm Copper.*—Acidify with acetic acid. Test for copper by the K₄Fe(CN)₆ reagent. Reddish-brown colored compound proves Copper. (Cu₂Fe(CN)₆). *B. Confirm Cadmium* by adding KCN solution to the second portion and passing in H₂S. A yellow precipitate is CdS. See Preliminary Tests.

TABLE IIB

9. *Separation of the Soluble H₂S Sub-group—Tin Division.*—The members of the sub-group are looked for in the ammonium polysulfide extract obtained in step 3, Table IIA.

Dilute this extract with an equal volume of water and add concentrated HCl in small portions until the solution is slightly acid, turning litmus paper red. Avoid more than 2-3 cc. of the acid in excess of the neutral point. The yellow color of the solution disappears and white sulfur and the yellow to brown sulfides of the group precipitate. A pure white color is generally only sulfur; arsenic, antimony and tin being absent. If the precipitate is colored the group is present. A dark color may be due to presence of the copper group.

Filter, using suction. Reject the filtrate. The precipitate may contain As₂S₅, yellow, Sb₂S₅, orange and SnS₂, yellow. Wash with water and drain. Reject washings.

10. *Separation of Arsenic Sulfide.*

Transfer the precipitate to a large bore test tube. Add 15 cc. of strong HCl (d. 1.2) and place the tube with its contents in a beaker of boiling water for about 10 minutes, shaking occasionally. Again saturate with H₂S, by connecting to an H₂S generator (bubbling the gas through the solution is unnecessary). Dilute with 5 cc. of water and filter. Drain. Save this filtrate for determining antimony and tin. Wash the residue with water containing a few drops of HCl. Reject the washings. Save the residue for arsenic determination.

11. *Confirmation of Arsenic.*

Residue.—As₂S₅ and S. (If the residue is dark colored, extract the As₂S₅ with NH₄OH, evaporate the extract to pastiness and continue as stated below.)

Filtrate.—SbCl₃, SnCl₄.
Test according to 12 below.

Transfer the arsenic residue to a small beaker and add 4-5 cc. of strong HNO₃. (If the NH₄OH extraction was made add HNO₃ to the evaporated residuc.) Heat gently to effect solution. Evaporate off the excess of HNO₃, (placing beaker on an asbestos mat in the hood). To the residue add 2 cc. of water and 2 cc. of NH₄OH. Filter into a test tube. (Reject the residue.) To the solution in the test tube add 10 cc. of magnesium ammonium nitrate reagent. Allow to stand a few minutes. The precipitate is MgNH₄AsO₄, colorless.

Confirm arsenic as follows; filter off the precipitate onto a small filter. Drain but do not wash. Add 2 cc. of 0.5 N AgNO₃, that has been acidified with 4-6 drops of acetic acid. A dark red residue, Ag₃AsO₄, will remain on the filter, proving the presence of Arsenic.

12. *Detection and Confirmation of Antimony and Tin.*—Divide the filtrate from the As₂S₅ in two equal portions, A and B.

Portion A Test for Antimony

Dilute with an equal volume of water and saturate with H₂S. An orange colored precipitate indicates Sb₂S₃. Filter off and dissolve in 5 cc. HCl. Add 10-15 cc. of water. Add a piece of tin foil. A black deposit, insoluble in NaOCl, or NaOBr, proves Antimony.

Portion B Test for Tin

Place in a test tube. Add 2 cc. HCl and a small piece of aluminum foil. Boil and few minutes and filter into a test tube containing 5-6 cc. of HgCl₂ test solution. A white to gray precipitate or cloudy solution will result in the presence of Tin: An iron nail may be used in place of aluminum.

CHART II, A
HYDROGEN-SULFIDE GROUP. COPPER AND TIN DIVISIONS

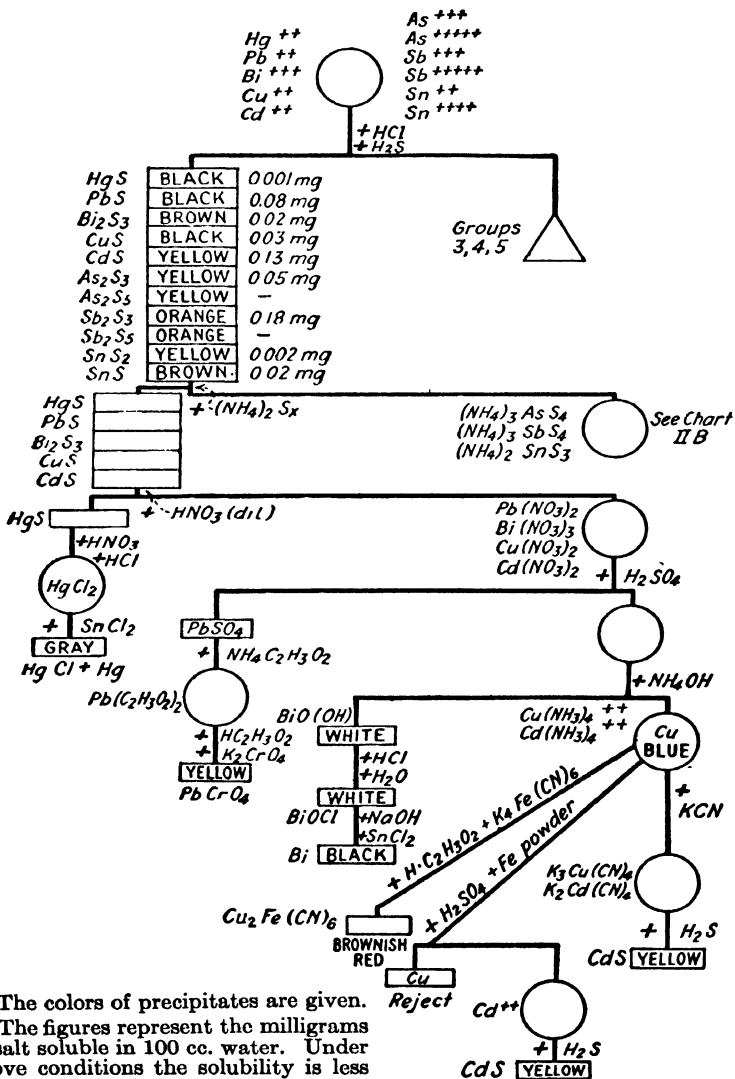

The colors of precipitates are given.
The figures represent the milligrams of salt soluble in 100 cc. water. Under above conditions the solubility is less than represented.

CHART II, B

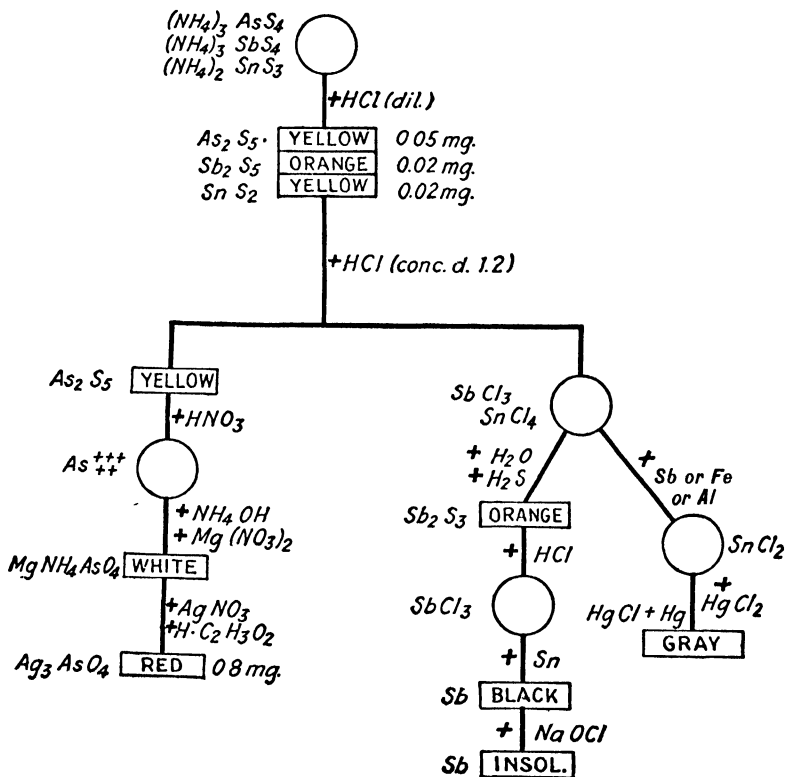
SEPARATION OF THE TIN DIVISION OF THE
HYDROGEN-SULFIDE GROUP

Notes.—The colors of the precipitates are given in the rectangles. The circles are solutions.

The solubility in milligrams of the precipitates per 100 cc. of water give the relative solubilities, but not the exact solubilities in presence of the salts that are formed in the separation. The figures represent the solubility in water.

CHEMICAL PRINCIPLES—HYDROGEN-SULFIDE GROUP

§ 18. **Copper Division.**—The separation of the members of this group from elements of following groups depends upon the fact that their sulfides are precipitated by H_2S from acid solution, while the sulfides of the following group elements remain in solution. The separation is based upon the acidity of the solution. The solubility of H_2S gas, according to Charles' Law, has a constant value under definite temperature and pressure. The ionization of the gas takes place in two stages: $\text{H}_2\text{S} \rightarrow \text{H}^+ + \text{HS}^-$ and $\text{HS}^- \rightarrow \text{H}^+ + \text{S}^-$ the final ions in solution being $2\text{H}^+ \text{S}^-$. This final form is the one that concerns our attention here, for upon this ionization depends the precipitation of the H_2S and the $(\text{NH}_4)_2\text{S}$ groups. According to the law of molar concentration (mass action) the product of the ion concentration of H^+ and S^- is a constant, i.e., 2H^+ multiplied by $\text{S}^- = K$. If the ion concentration of H^+ is increased, namely by the addition of a mineral acid such as HCl , the concentration of S^- ions must necessarily be decreased. The formula for the ionization constant of H_2S is
$$\frac{(\text{H}^+)^2 \times (\text{S}^-)}{\text{H}_2\text{S}} = K$$
, while the solubility product is $(\text{H}^+)^2 \times (\text{S}^-)$;

for example if the figures for the molar concentrations of H^+ and S^- were 2 and 32, respectively (many million times the amounts that are possible), the constant would be $2 \times 2 \times 32 = 128$, increasing the H^+ -ion concentration, by addition of an acid, to 4 would lower the concentration of S^- to 8, i.e., $4 \times 4 \times 8 = 128$. It is evident, therefore, that the addition of an acid decreases the S^- ions in the solution. On the other hand by addition of an alkali such as NH_4OH , the hydroxyl $-\text{OH}^-$ decreases the H^+ ions by formation of H_2O , thus causing an increase of the S^- ions. Should the S^- ion concentration sufficiently increase, the members of the $(\text{NH}_4)_2\text{S}$ group would precipitate. In neutral

solutions, saturated with H_2S the S^- ion concentration has been calculated to be 1.2×10^{-15} . With an acidity of 0.3N the S^- ion concentration drops to 1.22×10^{-22} , an enormous decrease. With the first S^- concentration certain members of the $(\text{NH}_4)_2\text{S}$ group will precipitate, notably Zn as ZnS , while with the later S^- ion concentration only the members of the H_2S group will precipitate. A solution with an acidity of 0.3N is a dividing line between the two groups allowing a certain margin of safety. We have learned that the *solubility product* is the product of the ion concentration of a compound in a saturated solution. If the concentration of either the basic or acidic radicals is increased the compound will precipitate. This increase is spoken of as "*exceeding the solubility product.*" As we have seen, the action is brought about by adding a substance that readily ionizes and furnishes a common ion with that of the compound to be precipitated (common ion effect). In the case of the H_2S group the solubility products of the sulfides are easily exceeded and the sulfides from the solutions are extremely low in S^- ion concentrations. This solubility product varies with the different members of the H_2S and the $(\text{NH}_4)_2\text{S}$ groups, so that with solutions of different acidity it is possible to make separations, not only between groups, but also between members of a group. Arsenic, for example, may be separated from antimony and tin by taking advantage of the fact that its sulfide solubility product is much more easily exceeded than either that of antimony or tin, and antimony may be separated from tin because the solubility product of its sulfide is more readily exceeded than that of tin. In the following arrangement of elements the solubility products of the sulfides of the first are more easily exceeded than are those that follow; the first are precipitated from more concentrated acid solutions than the latter. To obtain sulfide precipitates the acidity must decrease for the elements in the order named: As^{++++} , As^{+++} , Hg^{++} , Cu^{++} , Sb^{+++} , Bi^{+++} , Sn^{++++} , Cd^{++} , Pb^{++} , Sn^{++} , Zn^{++} , Fe^{++} , Ni^{++} , Co^{++} , Mn^{++} . Arsenic sulfide

precipitates from strong, moderately concentrated acid solutions, while zinc sulfide will tolerate only a weak, very dilute acid solution. A sufficient difference in this toleration exists between tin and zinc to enable us to have a dividing line between tin and zinc, so that we place the elements including and preceding tin in the H_2S group and those including and following zinc in the $(NH_4)_2S$ group.

SEPARATION OF THE COPPER DIVISION OF THE HYDROGEN-SULFIDE GROUP

§ 19. We will take up the elements in the order in which they are separated and identified.

1. *Mercury*.—We have already met with mercury in the first group and have learned that the monovalent form precipitates as a chloride, while the divalent form passes into solution. The latter form concerns us here. HgS is not appreciably soluble in $(NH_4)_2S_x$, in which the sulfides of arsenic, antimony, and tin dissolve readily; a chemical principle used in the separation of the sulfides of these *amphoteric* substances from mercury, lead, bismuth, copper, and cadmium. This principle will be considered later. During the precipitation of mercury a yellow compound is first obtained; this changes to black HgS with additional H_2S .

2. *Lead*.—We have already been introduced to lead in our study of the first group. The comparative solubility of $PbCl_2$ makes its removal in the second group necessary, since some of the $PbCl_2$ may pass into solution. PbS is separated from arsenic, antimony and tin sulfides by its comparative insolubility in $(NH_4)_2S_x$. It is separated from HgS by its solubility in dilute HNO_3 . Since $PbSO_4$ is slightly soluble in HNO_3 this acid is removed by evaporating the solution to small volume, the less volatile H_2SO_4 coming off when the HNO_3 has been expelled. The dense white fumes, due to H_2SO_4 , appear when the HNO_3 has been expelled. Should $PbSO_4$ dissolve it will interfere in the test for cadmium, the black PbS masking the yellow color of

CdS; hence the removal of lead at this stage is necessary in order to be able to detect Cd later.

The confirmatory test for lead is advisable since BaSO_4 might be precipitated with PbSO_4 , by a small amount being occluded in the H_2S precipitate. Furthermore $(\text{BiO})_2\text{SO}_4$ might precipitate here, both the BaSO_4 and $(\text{BiO})_2\text{SO}_4$ precipitates being easily confused for PbSO_4 . BaSO_4 is not appreciably soluble in ammonium acetate, $(\text{BiO})_2\text{SO}_4$ dissolves, but the yellow chromate $(\text{BiO})_2\text{CrO}_4$ is soluble in acetic acid while yellow PbCrO_4 is practically insoluble, hence its distinction and identification. PbCrO_4 is soluble in NaOH and KOH and in mineral acids.

3. *Bismuth.*—We have become acquainted with bismuth by its hydrolysis and precipitation from weak acid solutions. Thus if the concentration of HCl was not sufficient in the precipitation of the silver group, BiOCl would remain with the AgCl , etc. Upon dilution of the H_2S group solution the precipitation of bismuth oxychloride is apt to occur. This is readily converted to the sulfide, Bi_2S_3 , upon passing in H_2S , so that its precipitation does no harm.

Bismuth, with copper and cadmium are converted to the soluble sulfates by H_2SO_4 . (The basic sulfate, if formed, would remain with PbSO_4 as mentioned above.) By addition of NH_4OH in excess the $\text{Bi}(\text{OH})_3$ or BiOOH will precipitate. The hydroxides $\text{Cu}(\text{OH})_2$ and $\text{Cd}(\text{OH})_2$ dissolve in the excess of NH_4OH forming the complex ions $\text{Cu}(\text{NH}_3)_4^{++}(\text{OH})_2^-$ and $\text{Cd}(\text{NH}_3)_4^{++}(\text{OH})_2^-$. Hence by filtration Bi may be separated from Cu and Cd, since Bi^{+++} is incapable of forming the complex ion with NH_3 .

The hydroxide of Bi dissolved in HCl , and this solution highly diluted, results in the precipitation of BiOCl , due to *hydrolysis*. Look up the principle of hydrolysis in a general chemistry and be prepared to explain the reaction in this concrete case.

The reduction test of bismuth by sodium stannite is very characteristic. The stannite must be fresh as the stannate will not give the test.

The confirmatory test for bismuth is made as a small amount of lead may be present in the solution and precipitate with Bi on addition of NH_4OH .

4. *Copper*.—This is our first introduction to copper, as the chloride of copper is easily soluble so it would not appear with the silver group. Copper sulfide, CuS , dissolves in dilute HNO_3 , affording a method for separating it from HgS . The sulfate, CuSO_4 , is easily soluble enabling a separation of CuSO_4 from PbSO_4 . Reacting with NH_4OH this copper solution forms a light blue precipitate, $\text{Cu}(\text{OH})_2$, easily soluble in an excess of NH_3 and water to form the complex ion $\text{Cu}(\text{NH}_3)_4^{++}$, which gives the solution an intense blue color. This color is generally a sufficient confirmation of copper. Nickel also gives the blue colored solution, but its presence here is not apt to occur. The separation of bismuth as BiOOH is effected by adding an excess of NH_4OH , as has been shown.

If copper is present in very small amount the color of the solution will be faint. It is advisable to apply the ferrocyanide test, which is more delicate. The reddish brown precipitate of $\text{Cu}_2\text{Fe}(\text{CN})_6$ is seen best upon filtering the mixture, the precipitate remaining on the white filter. The precipitate is soluble in NH_4OH , so that it is necessary to acidify the solution before adding the ferrocyanide reagent. One part of copper may be detected in 200,000 parts of water.

Copper may be precipitated in metallic form from acid solutions by adding metallic iron, zinc or aluminum. The reason for this will become apparent by consulting the table of potential series, these metals appearing above copper, having a greater tendency to ionize or give up electrons than does copper, hence its displacement and precipitation as a metal. $\text{Cu}^{++} + 2e = \text{Cu}^\circ$, metal. This action is utilized in the removal of copper from solution in the detection of cadmium.

Copper is displaced from solution also by Sn° , Pb° , Bi° , Co° , Ni° , Mg° , and Cd° . See page 23.

Copper forms with a soluble cyanide, such as KCN , a complex

ion, considered by some authorities to have the composition $K_3Cu(CN)_4$. H_2S passed into this solution produces no precipitate. Advantage is taken of this "fixation of Cu" in the test for cadmium in presence of copper.

5. *Cadmium*.—The element forms a yellow sulfide, CdS , from an acid solution. CdS in appearance is very much like As_2S_3 or As_2S_5 , but its solubility is not so readily exceeded as that of the arsenic sulfides. If the acidity of the solution is much above 0.3N, CdS remains in solution. As_2S_3 and As_2S_5 precipitate from comparatively strong acid solutions.

CdS is insoluble in $(NH_4)_2S_x$, enabling its separation from the sulfides of arsenic, antimony, and tin. It dissolves in dilute HNO_3 and can thus be separated from HgS . $CdSO_4$ is soluble in water, hence its separation is effected from $PbSO_4$. An excess of NH_4OH added to the sulfate forms the soluble $Cd(NH_3)_4SO_4$ salt, hence the separation of cadmium from bismuth may be made. If this solution is acidified with a weak acid and $K_4Fe(CN)_6$ reagent added, a white precipitate of $Cd_2Fe(CN)_6$ is obtained. This does not interfere with the copper test, as the precipitate does not mask the brownish red color of $Cu_2Fe(CN)_6$.

When iron is added to a cadmium solution, Cd° is not precipitated, as Cd° is next to Fe° in the potential series and gives up electrons more readily than does Fe^{+++} . Cu° on the other hand is below Fe° in the series, hence is precipitated by Fe° . Advantage is taken of this in the separation and detection of cadmium in solutions containing copper ions.

KCN reacts with Cd ions forming the complex ion $K_2Cd(CN)_4^{++}$, according to the reaction given in exercise 12 in the copper division of the preliminary tests. If H_2S is passed into this solution CdS , yellow, precipitates. Copper, we have learned, forms a complex ion with KCN which is not effected by H_2S , hence it is possible to detect cadmium in presence of copper by adding sufficient KCN to the solution. Should lead or mercury be present a black precipitate will be obtained, masking the yellow CdS .

CHEMICAL PRINCIPLES—HYDROGEN-SULFIDE GROUP

§ 20. **Tin Division.**—Precipitation of the sulfides of arsenic, antimony and tin is conducted along with the precipitation of the copper division. Since arsenic, especially the pentavalent form, precipitates very slowly, it is always advisable to heat and test the filtrate with additional H_2S to ascertain whether the arsenic has been completely precipitated. Precipitation of arsenic from solutions heated to $80^\circ\text{--}90^\circ\text{C}$. is more rapid than from cold solutions.

Should HNO_3 be present in large amount it is advisable to add HCl and evaporate the solution to near dryness, to expel HNO_3 , and then to dilute to volume before adding H_2S , otherwise a large amount of free sulfur will be liberated and the precipitation retarded by the oxidizing action of HNO_3 .

Soluble sulfoarsenic acid is formed when a solution of H_3AsO_4 is treated with H_2S passed into dilute HCl solutions. The $\text{H}_3\text{AsO}_3\text{S}$ solution may absorb much of the H_2S before the arsenic sulfide appears. The compound is decomposed in hot solutions, hence precipitation is much more rapid from hot solutions than from cold. The decomposition takes place more rapidly in strongly acid solutions. From fairly strong HCl solutions and a rapid passage of H_2S into arsenic (pentavalent) solutions the As_2S_5 will precipitate. From cold dilute acid solutions the precipitate will consist of both As_2S_3 and As_2S_5 .

Free sulfur will precipitate as a finely divided precipitate, coagulating into a spongy lump, if an oxidizing agent is present; HNO_3 has been mentioned, FeCl_3 , chromates, permanganates, chlorates will also cause this oxidation, and are more objectionable than is HNO_3 , which with an acid concentration of 0.3N has very little action.

Ammonium sulfide converts the tin group elements—arsenic,

antimony and tin sulfides—into the soluble sulfo salts. The lower sulfides are oxidized by the reaction to the higher sulfides, so that the same sulfo compounds are obtained with Sb_2S_5 and Sb_2S_3 or with As_2S_5 and As_2S_3 , or with SnS_2 and SnS . (See Table and Chart II, B.)

Sodium sulfide may be used in place of ammonium sulfide. In this case practically all the HgS passes into the tin group and its detection is made in this group division. Some prefer this division solvent, since it is easily prepared. It is a better solvent for separating tin from the copper division, for as much as 15 mg. of tin may be retained by the copper division by 500 mg.* of this group when $(\text{NH}_4)_2\text{S}_x$ is used.

10 cc. of $(\text{NH}_4)_2\text{S}_x$ is sufficient to dissolve 500 mg. or more of the tin group. It is advisable to pour the sulfide repeatedly over the precipitate, following the last treatment with 2–3 cc. of fresh reagent. If preferred the precipitate may be transferred to a small porcelain dish by spreading the portion of the filter containing the precipitate on the edge of the dish and washing off the precipitate by means of the polysulfide into the dish and there allowing it to react. Separation is effected by filtration.

The sulfides are precipitated from the sulfo salt solution by adding HCl in sufficient amount to make the solution distinctly acid. A large excess of the acid is avoided since this would cause the SnS_2 to redissolve. The polysulfide reagent, when acidified, is decomposed and free sulfur liberated. This sulfur appears white or a pale yellow color.

Should mercury or copper contaminate the tin group the precipitate will be dark in color. The tin group may be extracted by treating this impure precipitate with strong NH_4OH . HgS , Bi_2S_3 , CuS , SnS_2 , and free S° remain insoluble.

• 1. *Arsenic*.—The pentavalent arsenic precipitates as As_2S_5 when the sulfo salt is acidified. Separation from antimony and tin depend upon the slight solubility of this sulfide in concentrated

* A. A. Noyes—Qualitative Chemical Analysis.

HCl, while Sb_2S_5 and SnS_2 dissolve. In order to have the acid concentrated it is necessary to remove the greater part of the water from the precipitate. This is done by filtration through a filter reinforced by a hardened filter or a fold of cheese cloth placed in form of a cone under the filter paper. Suction is applied by means of a filter pump, the filter funnel being placed in position on a suction flask. By means of a screw clamp on the rubber tube connection (Fig. 3) the pressure from the pump is decreased to prevent breaking of the filter paper by too violent suction. The sulfides and free sulfur precipitate is sucked dry, and then transferred by means of a flattened glass rod to a test tube, where it is treated with strong HCl according to the directions in Table IIB.

After removal of the antimony and tin sulfides the As_2S_5 residue, if yellow, is dissolved in strong HNO_3 . If the precipitate is dark it is extracted by NH_4OH and the extract evaporated and treated with HNO_3 . The acid is expelled, and arsenic precipitated from the concentrated water extract, as the crystalline $\text{MgNH}_4\text{AsO}_4$, by the magnesia mixture. Magnesium nitrate is preferable to the chloride, since the test for arsenic is confirmed by the AgNO_3 test and a chloride is to be avoided in this test (AgCl precipitated by a chloride.) It is advisable to allow the precipitation a few minutes to form, since this takes place slowly when As is present in small amount.

The confirmatory test with AgNO_3 is to distinguish the arsenic precipitate from $\text{Mg}(\text{OH})_2$, or other hydroxides that might form with NH_4OH . The brick-red precipitate is characteristic of arsenic.

The Marsh and Gutzeit tests for arsenic are exceedingly delicate. If time is not available for making these tests the student is advised to look up the methods for making these. Details of the Gutzeit method, and a color chart may be found in the author's work "Standard Methods of Chemical Analysis"

The Bettendorff test for arsenic depends upon the reduction

by SnCl_2 of arsenic to metallic state from a strong HCl solution.

The Reinsch's test depends upon the precipitation of metallic arsenic from a hot HCl solution by metallic copper, upon which a gray coating of the As appears.

The Gatchouse test evolves AsH_3 from a KOH solution by action of Al; while the Fleitmann test employs metallic Zn.

To distinguish arsenic from antimony in the Marsh test or in tests in which the elements are deposited by displacement, bear in mind that arsenic is soluble in sodium hypochlorite or hypobromide, while antimony is not.

2. *Antimony*.—We have met with antimony in our study of the silver group, where we learned that it would precipitate as SbOCl upon dilution of the solution. In this respect antimony is like bismuth. The SbOCl is easily converted to Sb_2S_3 by H_2S . Both the trivalent and pentavalent sulfides of antimony are soluble in $(\text{NH}_4)_2\text{S}_x$, enabling their separation from the copper division. Like arsenic the sulfide of antimony is precipitated from the sulfo salt solution by acidifying with HCl. The Sb_2S_3 that forms is soluble in strong HCl, enabling it to be separated from As_2S_5 , which is practically insoluble. In the process of solution the Sb^5 is reduced to trivalent form. Upon dilution and resaturation with H_2S , Sb_2S_3 precipitates. If the acidity is sufficiently concentrated and the solution is kept hot the Sb_2S_3 will be practically free of SnS_2 and a separation may thus be obtained. The confirmatory test may be made in the presence of Sn ions, when an estimation of quantity is not desired. Antimony may be displaced from its solution by metallic tin. This is due to the fact that tin has a greater tendency to form ions and give up electrons than antimony. In the potential series tin precedes antimony.

In the notes on arsenic we have learned that metallic arsenic stain was soluble in hypochlorite or hypobromite of sodium, while that of antimony was insoluble. Since arsenic is

apt to contaminate the extract the final confirmatory test should be made.

3. *Tin*.—We have had occasion to use tin in two previous tests for mercury. Tin forms two series of salts—stannic and stannous, where tin appears in tetravalent and in divalent form. Both SnS_2 and SnS are soluble in $(\text{NH}_4)_2\text{S}_x$, forming the sulfo salt $(\text{NH}_4)_2\text{SnS}_3$. Upon acidification the higher sulfide, SnS_2 (yellow), is precipitated. Strong acidification is avoided as SnS_2 would redissolve. (Not over 2.5 per cent HCl .)

The separation of SnS_2 by solution with HCl has been mentioned in the notes on arsenic. The sulfide is more soluble in moderately concentrated solutions than is Sb_2S_3 , hence tin may be kept in solution by adding sufficient HCl (1 : 5) while the antimony is precipitated and filtered off. SnS or SnS_2 may be precipitated from the antimony filtrate by dilution and saturating with H_2S .

A direct test for tin is made in presence of antimony by reducing SnCl_4 (H_2SnCl_6) with antimony powder. The reduction is carried only to divalent Sn^{++} , tin remaining in solution in the stannous form as SnCl_2 . It may now be tested for by addition of mercuric chloride solution. (This test is the compliment of the test for mercury with SnCl_2 with which we become acquainted in the silver group, as well as in the copper division of the H_2S group.) The precipitate is that of mercury not of tin, proving the presence of the strong reducing agent SnCl_2 .

Reduction of tin to the metallic state is effected by means of metallic Al° , Fe° or Zn° . It is necessary in this case to redissolve the Sn° in HCl before applying the HgCl_2 solution test. This resolution is unnecessary when powdered Sb° is used.

In the presence of oxalic acid, Sb_2S_3 may be precipitated by H_2S , while tin remains in solution. (Method of Welch and Weber.)

When hot dilute HNO_3 acts on metallic tin, a white substance is obtained, known as metastannic acid, $\text{Sn}_5\text{O}_5(\text{OH})_{10}$ or $5(\text{H}_2\text{SnO}_3)$. This is a polymer of stannic hydroxide, H_2SnO_3 . Stannic nitrate

is first formed and then hydrolyses to metastannic acid and HNO_3 . HCl converts this to $\text{Sn}_5\text{O}_5\text{Cl}_{10}$, insoluble in HCl . Water converts this to $\text{Sn}_5\text{O}_5\text{Cl}_2(\text{OH})_8$, insoluble in HCl , but soluble in water. Metastannic acid dissolves more readily in HCl , in presence of a reducing agent such as a piece of aluminum wire placed in the mixture.

Stannic chloride volatilizes at 114°C ., hence chloride solutions of tetravalent tin should not be taken to dryness in attempting a detection or determination of tin.

Stannic compounds are converted to metastannic forms by diluting and boiling. Metastannic compounds are converted to stannic form by boiling with strong KOH or HCl .

§ 21

CLASSROOM REVIEW OF THE HYDROGEN-SULFIDE GROUP

1. What effect would pressure and temperature have on the solubility of H_2S in water? Explain.

2. Why would a larger quantity of lead sulfide remain in solution in a 0.3N acid solution saturated with H_2S under ordinary conditions than when saturated under pressure?

Note.—Separation of the H_2S group in a pressure flask is recommended whenever this is possible.

3. What is the necessity for the confirmatory test for lead? Is not the precipitation with H_2SO_4 sufficient? What prevents $(\text{BiO})_2\text{CrO}_4$ from interfering in the lead confirmatory test?

4. The solubility of arsenic, antimony and tin is due to their amphoteric character. Explain.

5. From the electromotive series show why tin and antimony are used in the confirmatory tests for antimony and tin. Why not reduce these elements by adding zinc, iron or aluminum?

6. How does the HgCl_2 test for tin differ from the usual method in detecting an element?

7. In a solution saturated with PbS and H_2S (0.3N HCl sol.) in which lead existed in solution, what would occur if a little NH_4OH was added? Explain.

8. In a solution saturated with H_2S , containing a precipitate of ZnS , what would occur if HCl were added to bring the acidity to 0.3N? Explain.

9. How many cubic centimeters of $6N \cdot H_2SO_4$ are necessary to precipitate 500 mg. of $PbSO_4$, on the basis that all the sulfuric acid combines with the lead?

10. How much HCl is present in a solution of 1.2 density, per cubic centimeter. If this solution is diluted to five times its volume, how much HCl is present per cubic centimeter? What are the normalities of the two solutions?

11. $Sn(OH)_2$ is spoken of as an amphoteric substance. Why?

12. Explain why SnS_2 precipitates when $(NH_4)_2SnS_3$ is treated with HCl.

13. Upon what difference of solubility does the separation of arsenic from antimony and tin depend?

14. Why is copper metal insoluble in HCl? See electromotive series.

15. Why is it necessary to destroy an oxidizing agent before passing in H_2S for precipitating the H_2S group?

16. How may arsenic be distinguished from antimony when the two are displaced from a solution by a metal higher in the potential series?

17. Explain by means of the solubility product why $PbSO_4$ is more soluble in presence of HNO_3 than in pure water.

18. Explain in terms of the solubility product why $MgNH_4AsO_4$ dissolves in HCl.

19. Give the colors of the sulfides precipitated by H_2S in a slightly (0.3N) acid solution, all the members of the H_2S being present.

20. Complete and balance the following equations:

Group Reactions—Copper Division

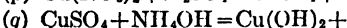
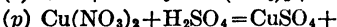
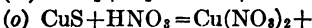
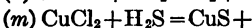
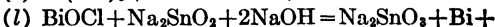
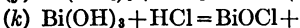
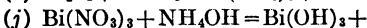
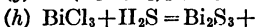
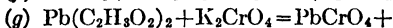
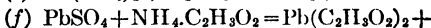
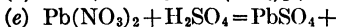
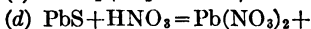
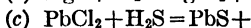
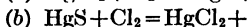
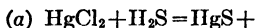

- (r) $\text{Cu}(\text{OH})_2 + \text{NH}_4\text{OH} = \text{Cu}(\text{NH}_3)_4 +$
 (s) $\text{CuSO}_4 + \text{Fe} = \text{Cu} +$
 (t) $\text{CuSO}_4 + \text{K}_4\text{Fe}(\text{CN})_6 = \text{Cu}_2\text{Fe}(\text{CN})_6 +$
 (u) $\text{Cu}(\text{NH}_3)_4\text{SO}_4 + \text{NH}_4\text{OH} + \text{KCN} = \text{K}_3\text{Cu}(\text{CN})_4 + \text{NH}_4\text{CN}$
 $+ \text{NH}_4\text{CNO} + \text{NH}_3 +$
 (v) $\text{CdCl}_2 + \text{H}_2\text{S} = \text{CdS} +$
 (w) $\text{CdS} + \text{HNO}_3 = \text{Cd}(\text{NO}_3)_2 +$
 (x) $\text{Cd}(\text{NO}_3)_2 + \text{H}_2\text{SO}_4 = \text{CdSO}_4 +$
 (y) $\text{CdSO}_4 + \text{NH}_4\text{OH} (xs) = \text{Cd}(\text{NH}_3)_4\text{SO}_4 +$
 (z) $\text{K}_2\text{Cd}(\text{CN})_4 + \text{H}_2\text{S} = \text{CdS} +$

Group Reactions—Tin Division

- (a) $\text{AsCl}_3 + \text{H}_2\text{S} = \text{As}_2\text{S}_3 +$
 (b) $\text{AsCl}_5 + \text{H}_2\text{S} = \text{As}_2\text{S}_5 +$
 (c) $\text{As}_2\text{S}_3 + (\text{NH}_4)_2\text{S}_x = (\text{NH}_4)_3\text{AsS}_4 +$
 (d) $\text{As}_2\text{S}_5 + (\text{NH}_4)_2\text{S} = (\text{NH}_4)_3\text{AsS}_4 +$
 (e) $(\text{NH}_4)_3\text{AsS}_4 + \text{HCl} = \text{As}_2\text{S}_5 +$
 (f) $\text{As}_2\text{S}_5 + \text{Cl}_2 (\text{Aq. reg.}) = \text{H}_3\text{AsO}_4 + \text{S} + \text{HCl} +$
 (g) $\text{H}_3\text{AsO}_4 + \text{MgCl}_2 + \text{NH}_4\text{Cl} = \text{MgNH}_4\text{AsO}_4 +$
 (h) $\text{H}_3\text{AsO}_4 + \text{AgNO}_3 = \text{Ag}_3\text{AsO}_4 +$
 (i) $\text{Sb}_2\text{S}_3 + \text{H}_2\text{S} = \text{Sb}_2\text{S}_5 +$
 (j) $\text{Sb}_2\text{S}_3 + (\text{NH}_4)_2\text{S}_x = (\text{NH}_4)_3\text{SbS}_4 +$
 (k) $(\text{NH}_4)_3\text{SbS}_4 + \text{HCl} = \text{Sb}_2\text{S}_5 + \text{H}_2\text{S} + \text{NH}_4\text{Cl}$
 (l) $\text{Sb}_2\text{S}_5 + \text{HCl} = \text{H}_2\text{S} + \text{SbCl}_3 + \text{S}$
 (m) $\text{SbCl}_3 + \text{Sn} = \text{Sb} +$
 (n) $\text{SbCl}_3 + \text{H}_2\text{C} = \text{SbOCl} +$
 (o) $\text{SnCl}_2 + \text{H}_2\text{S} = \text{SnS} +$
 (p) $\text{SnCl}_4 + \text{H}_2\text{S} = \text{SnS}_2 +$
 (q) $\text{SnS} + (\text{NH}_4)_2\text{S}_x = (\text{NH}_4)_2\text{SnS}_3 +$
 (r) $\text{SnS}_2 + (\text{NH}_4)_2\text{S}_x = (\text{NH}_4)_2\text{SnS}_3 +$
 (t) $(\text{NH}_4)_2\text{SnS}_3 + \text{HCl} = \text{SnS}_2 +$
 (u) $\text{SnS}_2 + 4\text{HCl} = \text{SnCl}_4 +$
 (v) $\text{SnCl}_4 + \text{Sb} = \text{SnCl}_2 +$
 (w) $\text{SnCl}_2 + \text{HgCl}_2 = \text{SnCl}_4 + \text{HgCl}$
 (x) $\text{AsCl}_3 + \text{Zn} + \text{H}_2\text{SO}_4 = \text{AsH}_3 +$

AMMONIUM-SULFIDE GROUP, IRON AND ALUMINUM DIVISIONS

Iron Division—Iron, Manganese, Cobalt and Nickel
Aluminum Division—Aluminum, Chromium, Zinc

The members of this group are precipitated from ammoniacal solution by addition of H_2S with formation of sulfides. The sulfides of two, Al_2S_3 and Cr_2S_3 , hydrolyze with formation of the precipitates $Al(OH)_3$ and $Cr(OH)_3$.

PRELIMINARY EXERCISES

§ 22. *A. Interfering Substances.*—Organic matter, oxalates, tartrates, phosphates interfere with the scheme of separation and detection of the members of the ammonium-sulfide group. The three first are usually destroyed in the preparation of the sample for analysis. Phosphates are not thus removed, and if present will interfere by causing the precipitation of the ammonium-carbonate group with the ammonium-sulfide group upon making the solution alkaline with NH_4OH . Provision is made for the removal of $PO_4^{=}$, should this be present. The effect of $PO_4^{=}$ is shown in Experiment 2 below.

1. Place in small beakers A and B, 5 cc. of iron and 5 cc. of calcium test solutions, a separate beaker for each solution. Dilute each solution to 50 cc. and add 5 cc. of HCl . Now add NH_4OH until the solution turns red litmus paper blue, the solution having a slight odor of ammonia. Observe that a precipitation occurs in the beaker containing iron.

2. *Effect of Phosphate.*—As in Experiment 1 place 5 cc. of iron solution in the beaker A and 5 cc. of calcium solution in the beaker B. Add 5 cc. of HCl and to each solution add 1 cc. of a soluble phosphate test solution. Now make alkaline with NH_4OH

(litmus paper test) and observe that precipitation takes place in both beakers. Compare results with test 1. What is the color of the iron precipitate in test 1 and in test 2?

3. *Removal of Phosphate Ions.*—Combine the two phosphate precipitates obtained in Experiment 2. Add, drop by drop, acetic acid until the precipitate dissolves, and then dilute NH_4OH dropwise until a slight precipitate forms. If the precipitate is not brownish red in color add a few drops of ferric chloride test solution until a brown color is obtained. Again dissolve the precipitate in a few drops of acetic acid and add 5 cc. of a 50 per cent solution of ammonium acetate. Dilute to about 100 cc. with water and heat to boiling. Filter off the precipitate and test the filtrate for calcium and for PO_4^{3-} as directed under 4 and 5.

4. *Test for Calcium.*—To about half of the filtrate obtained above add a solution of ammonium oxalate. The formation of a white precipitate shows the presence of calcium. How can you account for calcium not remaining with FePO_4 ? See Experiment 2.

5. *Test for Phosphate.*—Acidify the remaining half of the filtrate from Experiment 3 adding dilute HNO_3 until the solution reddens blue litmus paper. Gently warm the solution and add about 20 cc. of ammonium molybdate reagent. A yellow precipitate shows the presence of a phosphate. In this case no precipitate forms. Why?

Dissolve the iron precipitate obtained in Experiment 3 by adding a few cubic centimeters of dilute HNO_3 and repeat the phosphate test given above. A precipitate forms. Explain.

What do the above tests suggest as to a method for the removal of the phosphate ion? Why is this removal necessary in the separation of the ammonium sulfide from the ammonium carbonate group?

B. Separation of the Iron and the Aluminum Divisions.—

1. Arrange seven large test tubes side by side in a test tube rack, each test tube having been labeled with the symbol of the element

it is to contain. In the tube with the Fe label place 5 cc. of Fe test solution; in the Mn test tube 5 cc. of the Mn test solution; in the Ni, Co, Al, Cr, Zn test tubes 5 cc. of their respective reagents. To each tube add 2 cc. of HCl (d. 1.2) followed by sufficient NH_4OH to neutralize the free acid and make the solutions alkaline to litmus paper. Does precipitation take place in any of the test tubes? What are the color of the precipitates $\text{Fe}(\text{OH})_3$, $\text{Cr}(\text{OH})_3$ and $\text{Al}(\text{OH})_3$?

Note.—Zinc, nickel, cobalt and manganese would also precipitate if it were not for the presence of NH_4Cl , formed by the action of NH_4OH on HCl in the solutions. Prove this by adding NH_4OH to the neutral solutions of zinc, nickel, cobalt and manganese. Add the dilute NH_4OH very cautiously and observe the color of the precipitates. Do these dissolve in an excess of NH_4OH ?

2. Connect the test tubes in series to a hydrogen sulfide generator (HOOD) and pass in H_2S through the series, just as you did in the experiment with the H_2S group, saturating the solutions with H_2S under pressure. Observe the color of the precipitates formed: FeS , black; MnS , pink; CoS , black; NiS , black; $\text{Al}(\text{OH})_3$, colorless; $\text{Cr}(\text{OH})_3$, green; ZnS , white.

3. Decant the solutions from the precipitates. To each precipitate add 10–15 cc. of dilute N. HCl (1 part HCl (d. 1.2) to 10 parts of water) and warm gently. Observe that all the precipitates dissolve with the exception of CoS and NiS . This fact is used in separating Ni and Co from the other elements of the group.

4. Add to each test tube sufficient NaOH reagent to neutralize the free acid (litmus paper test) and to make the solution strongly alkaline. Observe that precipitates are formed with iron, manganese, cobalt and nickel, but that aluminum, chromium and zinc form solutions with the excess of NaOH. The compounds formed are $\text{Fe}(\text{OH})_3$, $\text{Mn}(\text{OH})_2$, $\text{Co}(\text{OH})_2$, $\text{Ni}(\text{OH})_2$; NaAlO_2 , NaCrO_2 , Na_2ZnO_2 . A method of separations divides the group into two subgroups taking advantage of the reactions shown here.

5. By means of a spatula add a little Na_2O_2 powder to each of

the test tubes, or if preferred add a few cubic centimeters of H_2O_2 . Observe the darkening of the manganese precipitate ($\text{MnO}(\text{OH})_2$ formed), note the yellow color produced in the chromium test tube due to the formation of Na_2CrO_4 . The $\text{Co}(\text{OH})_2$ is oxidized to $\text{Co}(\text{OH})_3$ by the peroxide.

C. In separate tubes precipitate the sulfides NiS , CoS , MnS , FeS , ZnS and the hydroxides $\text{Al}(\text{OH})_3$, $\text{Cr}(\text{OH})_3$. 1. Decant off the solutions from the precipitates, rejecting the solutions and retaining the precipitates in the test tubes. Wash once by decantation. Add to each precipitate 10 cc. of concentrated, colorless, HNO_3 (d. 1.4) and about 0.5 cc. of KClO_3 crystals. Heat gently. Observe that all the precipitates dissolve. On heating, the manganese again precipitates (HCl must be absent as this dissolves the precipitate). The $\text{MnO}(\text{OH})_2$ changes to MnO_2 . The remaining members are changed to soluble nitrates. This suggests a method for separating Mn from the other elements.

2. Add 10 cc. of water to the solutions. Add NH_4OH until the acid is neutralized and the solutions smell of ammonia. Note the precipitates, add $(\text{NH}_4)_2\text{CO}_3$ and boil. Note the tubes in which the precipitates remain. Now add NaOH and Na_2O_2 and boil. Do any of the precipitates dissolve? What is the color of the chromate solution?

3. Study the method for separation of nickel and cobalt in the table of separations. Make the following test with 5 cc. portions in separate test tubes. Add NaOH solution a few drops at a time until precipitates form. Now dissolve the precipitates in a few drops of dilute acetic acid. Add to each solution 2–5 cc. of potassium nitrite, KNO_2 reagent. Potassium cobaltic nitrite, $\text{K}_3\text{Co}(\text{NO}_2)_6$, yellow, precipitates; nickel remains in solution. This method serves in the separation of cobalt and its identification. (The formula of the crystallized compound may be written $2\text{Co}(\text{NO}_2)_3 \cdot 6\text{KNO}_2 \cdot 3\text{H}_2\text{O}$.)

D. *Separation of the Aluminum Division.*—1. Acidify the solutions containing NaAlO_2 , Na_2CrO_4 and Na_2ZnO_2 with HCl .

(Litmus paper test.) Now add NH_4OH until the solutions are faintly alkaline. Observe that precipitation of aluminum ($\text{Al}(\text{OH})_3$) alone occurs, while chromium and zinc remain in solution. ($(\text{NH}_4)_2\text{CrO}_4$, $\text{Zn}(\text{NH}_3)_4^{++}$.)

Note.—Should Cr^6 be reduced to Cr^3 , chromium will precipitate as green $\text{Cr}(\text{OH})_3$.

E. Study the procedure of separation of chromium and aluminum in the table of separations. Also the separation of manganese from iron.

F. Confirmatory Tests.—1. *Manganese.*—If the manganese dioxide obtained in *C1* is treated with H_2O_2 and a little water and gently heated, the precipitate will dissolve (consult the notes following the separation tables). Sodium bismuthate powder added to this solution will produce an intense purple colored solution due to the formation of the colored permanganate. Delicacy 0.000005 g. Mn per 50 cc. of solution. Chlorides must be absent as these interfere in the test.

2. *Iron.*—If the precipitate of $\text{Fe}(\text{OH})_3$, obtained in *C2* is dissolved in a few drops of HCl and diluted with water and the solution divided in two portions the following tests may be made to further confirm the presence of iron.

(a) Add to one portion potassium ferrocyanide, $\text{K}_4\text{Fe}(\text{CN})_6$, solution. A blue colored compound $\text{Fe}_4(\text{Fe}(\text{CN})_6)_3$, Prussian blue is formed. Delicacy 0.0000002 g. Fe per 100 cc. of solution.

(b) Add to a second portion a solution of KCNS or NH_4CNS . A red compound, $\text{Fe}(\text{CNS})_3$, is formed. Delicacy 0.00000007 g. Fe per 100 cc.

3. *Cobalt.*—The potassium cobaltic nitrite test given in *C3* is a confirmatory test for cobalt.

Nitroso-beta-naphthol in 50 per cent acetic acid added to a cobalt solution slightly acidified will precipitate a brick-red compound.

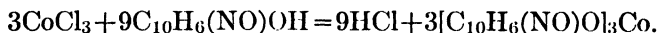

4. *Nickel*.—An alcoholic solution of dimethyl glyoxime added to a solution of nickel will give a red compound, $[(\text{CH}_3)_2\text{C}_2\text{N}_2\text{O}_2\text{H}]_2\text{Ni}$. Delicacy 0.0000003 g. Ni may be detected in 100 cc. of solution.

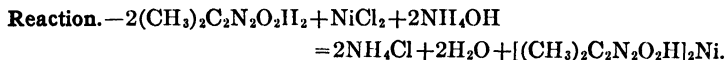

5. *Aluminum*.—The precipitate obtained in D1 is dissolved in a few drops of dilute HCl (1 : 3). To this solution add about 3 cc. of 20 per cent solution of $\text{NH}_4\text{C}_2\text{H}_3\text{O}_2$ and 5 cc. of aluminon reagent (0.5 per cent solution). Make faintly alkaline with NH_4OH , add 1 cc. of 10 per cent solution of $(\text{NH}_4)_2\text{CO}_3$. A bright red precipitate of $\text{AlC}_{22}\text{H}_{13}\text{O}_8$ will be obtained. Consult also the cobalt nitrate fusion test for aluminum given in the tables.

Note.—The fusion tests for aluminum and zinc may be made as follows: Pure ignited asbestos, held in a ball, half the size of a pea, by means of a platinum wire, is dipped into a solution of 0.05N cobalt nitrate, and then ignited; this is now dipped into the solution to be tested. (The solution of the hydroxide dissolved in HNO_3 .) The asbestos again ignited. The fibre is colored blue by aluminum and green by zinc.

Method of Gemmill, Brackett and McCrosky. J. A. C. S. 51, 1165 (1929).

6. *Chromium*.—The yellow colored solution produced by presence of a chromate is generally a sufficient test for chromium. If this solution is heated and a few cubic centimeters of lead acetate solution are added a yellow precipitate of PbCrO_4 will be obtained. If SO_4 ions are present add a little ammonium acetate and a few drops of acetic acid to prevent the formation of PbSO_4 precipitate.

Ether Peroxide Test.—Dissolve the PbCrO_4 in a few drops of dilute HNO_3 (1 : 10). Place in a test tube and add 4–5 cc. of ether and 2–3 cc. of 3 per cent H_2O_2 and shake and allow the ether to separate. The ether layer will be colored blue due to the presence of chromium. Consult the notes following the tables of separations.

7. *Test for Zinc.*—Study the confirmatory tests given in the tables of separations and in the notes that follow. The confirmatory test for zinc is advisable since free S, forming at this stage, may be mistaken for ZnS.

G. If time permits it is advisable to make a composite solution containing all of the members of the ammonium-sulfide group and effect a separation and identification of each member according to the tables that follow.

H. Get an UNKNOWN from your instructor and identify the elements present according to the table of separation and identification that follow.

SEPARATION OF THE AMMONIUM-SULFIDE GROUP—
IRON AND ALUMINUM DIVISIONS

Preparation of the Solution.—Since oxalates, tartrates, organic matter interfere in the procedure these should be removed by oxidation or ignition. This is accomplished with the original material.

Phosphates are removed by addition of a solution of ferric iron according to the method outlined in the preliminary exercises at the beginning of the group tests. Should phosphates remain, upon making the solution alkaline, calcium, strontium, barium and magnesium would precipitate with the members of the ammonium-sulfide group. A preliminary test for phosphate with ammonium molybdate is made on a small portion of the solution. If PO_4 is found to be present, a second small portion is tested for iron, by taking to dryness with HCl, taking up with a little water and a few drops of HCl and adding either KCNS or $\text{K}_4\text{Fe}(\text{CN})_6$ reagent, iron producing a red color with the first and a blue with the latter. All of the iron and phosphate are removed by the basic acetate method. This is generally accomplished after the separation of the aluminum subdivision. Mention of this step will be made in the outline that follows.

A

Procedure—Precipitation

1. The ammonium-chloride and hydrogen-sulfide groups having been removed according to Tables I and II, the filtrate from the H_2S group is taken for analysis.

Boil the solution to expel the H_2S , testing the vapors coming off with lead acetate paper. (H_2S blackens the lead acetate paper.) Add 5 cc. of 20 per cent NH_4Cl . (This prevents precipitation of magnesium with the group), and then add ammonia, NH_4OH , until the solution is alkaline (red litmus turning blue in the solution). Observe the color of precipitates that form. $\text{Fe}(\text{OH})_{2-3}$, green to reddish brown; $\text{Al}(\text{OH})_3$, colorless; $\text{Cr}(\text{OH})_3$, dirty green. If phosphates are present the precipitates may all appear white, Ca, Sr, Ba, Mg will precipitate. Should no precipitate appear, iron, aluminum and chromium are absent.

2. Pass H_2S into the solution until it is saturated. (Lead acetate paper held over the solution will turn black.) Coagulate the precipitate by heating and stirring. Filter and wash the precipitate with water containing a little $(\text{NH}_4)_2\text{S}$ (1 per cent). Save the filtrate, but reject the washings. The precipitate, during the washing, should be kept covered with a watch glass to prevent oxidation. Add H_2S to filtrate, boil, filter through a separate filter if a precipitate forms and add this to the main precipitate, which contains the group to be examined. The filtrate contains subsequent groups.

Precipitate.— $\text{Al}(\text{OH})_3$, $\text{Cr}(\text{OH})_3$, FeS , black, NiS , black, CoS , black, MnS , pink, ZnS , white. (If PO_4 is present Ca, Sr, Ba, Mg will be present.)

Filtrate.—Subsequent groups. If the $(\text{NH}_4)_2\text{CO}_3$ group is to be determined, boil immediately to expel H_2S and prevent SO_4 formation which would cause a precipitation of BaSO_4 .

3. Separations.

Transfer the precipitate to a 100–150 cc. beaker and add 20–25 cc. of cold, dilute HCl (1 : 10), stir and filter rapidly. The residue will contain (if present in the original sample) Ni and Co as sulfides. The filtrate will contain Fe, Mn, Al, Cr and Zn.

TABLE III.—Continued.

<p>4. Residue—NiS, CoS. Add 5 cc. conc. HCl (d. 1.19) and then to hot solution, drop by drop conc. HNO₃. Boil to expel Cl and NO₂. Add NH₄OH until alkaline to litmus. Acidify with a few drops of acetic acid. Divide in two portions. Test one portion for Ni using dimethyl glyoxime. Red precipitate due to [(NH₃)₂C₂O₂N₂H]₂Ni. Test the second portion for Co using nitroso B naphthol. Brick red precipitate is produced by Co. See also C 3, preliminary exercises.</p>	<p>6. Filtrate—MnCl₂, FeCl₃, AlCl₃, CrCl₃, ZnCl₂. Boil to expel H₂S. Add a few drops of HNO₃ to oxidize Fe⁺⁺. Make alkaline with slight excess of NH₄OH. (Litmus paper test), add 15 cc. 1N. (NH₄)₂CO₃. Heat to boiling and filter.</p> <p>6. Precipitate—MnCO₃, Fe(OH)₃, Al(OH)₃, Cr(OH)₃. Dissolve precipitate in a few drops of HCl. Make alkaline to litmus with NaOH solution. Cool and add in small portions a little Na₂O₂ powder using porcelain spatula. Boil to decompose xs. peroxide. Filter, saving the filtrate and the precipitate (8, 9). H₂O₂ may be used in place of Na₂O₂ to oxidize Cr.</p>	<p>7. Filtrate—Zn(NH₄)₂. Add acetic acid until solution is acid to litmus. Pass in H₂S. A white precipitate is ZnS. If the precipitate is dark or if finely divided, confirm further. Filter. Dissolve precipitate in a few drops of HNO₃. (Add solution from B 6.) Add 1-5 drops of Co(NO₃)₂ sol. Evaporate to dryness. Add 2-3 cc. Na₂CO₃ reagent. Evaporate. Ignite. A green residue proves Zinc (CoZnO₂). See Notes for optional method. Consult procedure below.</p>
<p>8. Precipitate—MnO(OH)₂, Fe(OH)₃. Transfer the precipitate to a small beaker and add 10-15 cc. of strong HNO₃. Heat to boiling and add in small portions about 1 cc. of KClO₄ crystals. The solution will darken and MnO₂ will precipitate. Add 1-2 cc. more of KClO₄, again heat and filter, through asbestos. (A wad of glass wool the size of a pea is placed in the apex of the funnel attached to a filter flask. Asbestos suspended in water is poured into the funnel, using suction, until a layer about $\frac{1}{8}$ inch in thickness has formed.)</p>		<p>9. Filtrate—NaAlO₂, Na₂CrO₄. (Yelow solution.) Acidify with HNO₃ and then make alkaline to litmus with NH₄OH. Filter.</p>

<p>10. Precipitate— MnO₂.</p> <p><i>Manganese.</i>—Place under the filter a test tube. Dissolve the MnO₂ by pouring over it about 10 cc. of hot dilute HNO₃ containing 1–2 cc. 3 per cent solution of H₂O₂. (If preferred the asbestos with the precipitate may be placed in a test tube and the acid with H₂O₂ added and heated.) Cool and add BiO₂ powder, by means of a spatula, until some brown powder settles. In presence of Manganese a purple color is obtained. (HMnO₄). Red lead or PbO₂ may be used in place of BiO₂. In this case boiling is necessary for oxidation.</p>	<p>11. Filtrate—Fe. Make alkaline with NH₄OH. A red precipitate indicates Fe(OH)₃. Filter.</p> <p><i>Confirmation of Iron.</i>—Dissolve the precipitate in a few cubic centimeters of dilute HCl. Divide in two portions. (a) To one portion add a few drops of K₄Fe(CN)₆ reagent, the blue color is due to Fe₄(Fe(CN)₆)₃, proving iron. (b) To the other portion add a solution of KCNS or NH₄CNS. A red color is due to (FeCNS)₃, proving iron.</p>	<p>12. Precipitate— Al(OH)₃ Confirm Al as per paragraph 5, page 59 or as follows: Dissolve the precipitate in a few drops of HNO₃, add 1–10 drops of dilute solution of cobalt nitrate (6 per cent sol.); make alkaline with NH₄OH and filter. Tear off the portion of the filter containing the precipitate and ignite this portion in a small porcelain crucible. A blue colored ash proves the presence of Aluminum.</p>	<p>13. Filtrate— Na₂CrO₄ Add 0.5–1 cc. solid ammonium acetate and acidify with acetic acid. Now add 1 cc. lead acetate sol. A yellow ppt. is PbCrO₄. If the precipitate is dissolved in a few cubic centimeters of HNO₃ solution are added and to the cold solution are added 4–5 cc. of ether, shaken and allowed to separate, the ether layer will have a blue color in presence of Chromium, (H₂CrO₇?).</p>
--	---	---	---

Zinc—In presence of iron take 10 cc. of solution. Add 2 cc. of 85 per cent H₃PO₄, 1 drop of copper reagent (0.5 g. CuSO₄·5H₂O, 0.5 g. conc. H₂SO₄, per 100 cc. H₂O) and 4 drops of test reagent (8 g. HgCl₂, 9 g. NH₄SCN in 100 cc. H₂O). Zinc produces a violet colored precipitate.

Make a diagram of the above outline for the separation of the group using quadrangles for precipitates and circles for filtrates.

CHART III

OUTLINE FOR SEPARATION OF AMMONIUM SULFIDE GROUP

Test for phosphate ions. These can be removed by Fe, added in excess, remembering to make a separate test for presence of Fe on a portion of the sample, and also that Al and Cr precipitate with NH_4OH , soluble in acids.

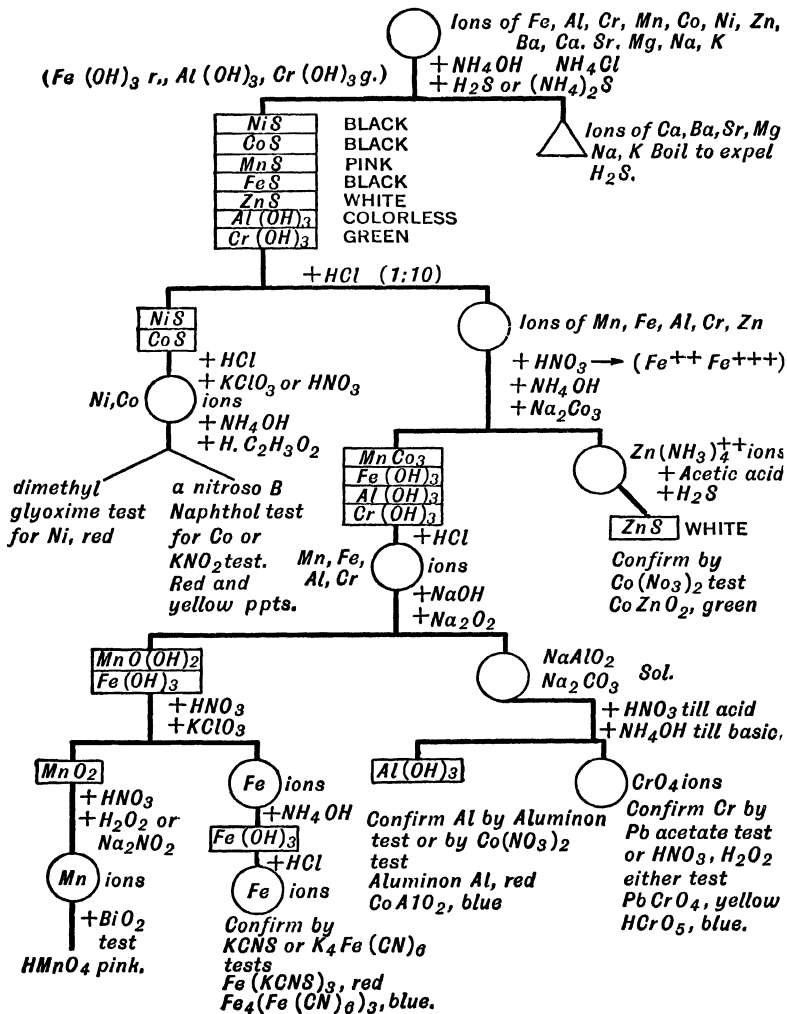

Treatment for Phosphates.

Test a small portion of the sample solution of the group for Iron.

To the remainder add NH_4OH until a precipitate forms that dissolves slowly. If the precipitate is not red add drop by drop FeCl_3 solution until a red colored precipitate is evident with addition of a few drops of NH_4OH . If a precipitate forms that does not dissolve, add a few drops of acetic acid until it shows an acid reaction. Now add 5-6 cc. ammonium acetate reagent. Dilute to about 100 cc. Boil a few minutes and filter. The precipitate contains all of the PO_4 and some basic acetate of iron. The filtrate contains nickel, cobalt, zinc, the alkaline earths, if these were present in the original sample.

Reject the Precipitate**Save the Filtrate**

Precipitate the group as sulfides as described in Table III. The filtrate will contain Ca, Ba, Sr, etc.

Special Tests

Determination of the State of Oxidation.—The original solution must be tested to ascertain the state of oxidation.

Distinction between Ferrous and Ferric Salts.—*Ferrous Salts* react with potassium ferri-cyanide, $\text{K}_3\text{Fe}(\text{CN})_6$, forming a blue precipitate or solution according to the concentration. (Turnbull's blue) $\text{Fe}_3(\text{Fe}(\text{CN})_6)_2$ is formed. A brown to green color is produced by ferric salts with $\text{K}_3\text{Fe}(\text{CN})_6$.

Ferric Salts react with potassium sulfo-cyanate, or thio-cyanate (also ammonium thio-cyanate), producing a red precipitate or solution according to the concentration of iron. Ferrous salts produce no color with KCNS or NH_4CNS .

Ferrous Salts react with NH_4OH producing green $\text{Fe}(\text{OH})_2$ oxidizing to red $\text{Fe}(\text{OH})_3$. Ferric salts with NH_4OH form red $\text{Fe}(\text{OH})_3$.

Chromium.—*Trivalent Chromium* reacts with NH_4OH giving a green precipitate of $\text{Cr}(\text{OH})_3$. *Hexavalent Chromium* colors solutions yellow and forms yellow precipitates with soluble salts of lead and barium.

Chromate (Hexavalent). Chromium reacts with *diphenyl carbazide*, $\text{CO}(\text{NH}.\text{NH}.\text{C}_6\text{H}_5)_2$ producing a violet pink color. Less than 0.0001 mg. of chromium may be detected. To 5 cc. of the chromate, 2 drops of acetic acid are added and 1 drop of the reagent (0.2 g. dissolved in 5 cc. of glacial acetic acid and diluted to 20 cc. with ethyl alcohol).

Manganous Salts are Pink.—In presence of water, the color is faint. *Permanganates* produce violet colored solutions. The divalent manganese is a good reducing agent, while the septavalent (permanganate) is a strong oxidizing agent. The tetravalent form is the most stable, MnO_2 occurring in nature.

Cobalt.—Divalent anhydride is blue, with water pink. $\text{Co}(\text{OH})_2$ is pink, $\text{Co}(\text{OH})_3$ by oxidation of $\text{Co}(\text{OH})_2$ is black.

SUMMARY AND CHEMICAL PRINCIPLES—AMMONIUM-SULFIDE GROUP

§ 24. **Precipitation and Group Separation.**—The members of this group are precipitated as sulfides from ammoniacal sulfide solutions. Two of these hydrolyze, Al_2S_3 as $\text{Al}(\text{OH})_3$ and Cr_2S_3 as $\text{Cr}(\text{OH})_3$. Should $-\text{PO}_4^{\equiv}$ radical be present, calcium, barium, strontium, magnesium would precipitate as phosphates with the $(\text{NH}_4)_2\text{S}$ group and iron would precipitate as white FePO_4 . In order to effect a separation of the $(\text{NH}_4)_2\text{S}$ and $(\text{NH}_4)_2\text{CO}_3$ groups in presence of $-\text{PO}_4^{\equiv}$, the phosphate radical is removed by addition of sufficient ferric salt to combine with the $-\text{PO}_4^{\equiv}$ as FePO_4 . This is accomplished in the presence of ammonium acetate. The solubility product of FePO_4 is exceeded more readily than that of the phosphates of any of the elements in question. A separate test for iron must be made if phosphates are present. The table of separation makes provision for $-\text{PO}_4^{\equiv}$ removal after separation of the two divisions of the group, and the removal of manganese in an acid solution, $-\text{PO}_4^{\equiv}$ passing into solution with Fe, Co, Ni and occluded Zn, together with the alkaline earths that may be present. Precipitation of the phosphates takes place on making the solution ammoniacal. It is necessary, therefore, to make a test for $-\text{PO}_4^{\equiv}$ before undertaking a separation of the group. Other interfering substances, namely, organic matter, oxalates, tartrates, etc., are provided for in the preparation of the sample.

We have already learned about the chemical principles involved in the precipitation of the group in our study of the H_2S group. Repression of the H^+ ions by addition of NH_4OH increases the S^- ions of H_2S in solution to a concentration sufficient to exceed the solubility products of the sulfides of the members of the $(\text{NH}_4)_2\text{S}$ group, causing their precipitation.

Before adding NH_4OH to repress H^+ ions, the solution is boiled to expel H_2S in order that the precipitation of $\text{Al}(\text{OH})_3$, colorless, $\text{Cr}(\text{OH})_3$, green, and $\text{Fe}(\text{OH})_{2-3}$, green, changing to red, may be observed. Ammonium hydroxide would afford a convenient method for subdividing the group were it not for the fact that the hydroxides of Al, Cr and Fe occlude appreciable amounts of Zn and Mn, necessitating their detection with these hydroxides.

The fact that the amphoteric aluminum, chromium and zinc form soluble salts with the strong base NaOH may be used in separating these three from iron, manganese, cobalt and nickel. Some zinc is apt to be held by the hydroxides precipitated by NaOH. Before making this separation, the entire group is precipitated from an ammoniacal solution by the addition of H_2S (or $(\text{NH}_4)_2\text{S}$); affecting, in absence of $-\text{PO}_4$, its separation from the alkalis and alkaline earths. The precipitates that form are: $\text{Al}(\text{OH})_3$, colorless;* $\text{Cr}(\text{OH})_3$, green; ZnS , white; MnS , pink; FeS , black; CoS , black; and NiS , black. Some nickel may escape precipitation and pass into the filtrate, coloring it brown. Boiling this filtrate generally accomplishes the precipitation of the NiS , which is filtered off and added to the main precipitate. Oxidation of the sulfides to sulfates by the air will cause them to dissolve, hence it is necessary to prevent, as far as possible, the action of air on the precipitate by washing rapidly with water containing a little $(\text{NH}_4)_2\text{S}$ reagent. Solution of the precipitates is effected by acidification with HCl. The sulfides of Ni and Co are difficultly soluble, a property useful in separating these from the other members of the group. Oxidation to sulfates by addition of KClO_3 accomplishes solution of NiS and CoS .

Separations in the Analysis of the Ammonium Sulfide Group (Table III).—In this procedure advantage is taken of the insolubility of NiS and CoS in dilute 1N. HCl, while the remaining elements, present as sulfides or hydroxides, are converted to

*Appears white in appreciable amounts.

the soluble chlorides. Nickel and cobalt are now tested for as usual.

Manganese is precipitated as carbonate together with the hydroxides of iron, aluminum and chromium in a filtrable form, while zinc passes into solution as the soluble zinc ammonium ion. It is thus separated from the other members of the group and precipitated, from an acetic acid solution, as white ZnS . CoS and NiS form slowly, if traces are present with zinc, so that these do not interfere.

The separation of manganese and iron from aluminum and chromium, by converting chromium to the hexavalent soluble chromate and aluminum to the soluble sodium salt, is accomplished by addition of an excess of $NaOH$ and Na_2O_2 .

Manganese is separated from iron by bringing the two compounds of these into solution with HNO_3 and then throwing out MnO_2 by means of $KClO_3$, as in the first procedure. The two elements are now detected as usual.

Aluminum hydroxide is precipitated by neutralizing the strong alkali with HNO_3 and then making alkaline with the weak base NH_4OH . The chromate remains in solution. Aluminum and chromium are now detected according to a procedure outlined in the first method.

This optional method is recommended by Sneed, Heisig and Trovatten (Jan., 1928 number of the Journal of Chemical Education). By precipitation of manganese as carbonate with the hydroxides of aluminum, chromium and iron, the detection of zinc is made more certain. The aurin tricarboxylate test for aluminum, the lead acetate test for chromium, and the nitroso-beta-naphthol test for cobalt ions offer a marked improvement in the identification of these ions.

STUDY OF THE ELEMENTS

1. *Cobalt*.—The cobalt and nickel ions form a complex ammonium ion when their solutions are treated with an excess of NH_4OH .

The sulfide CoS dissolves with difficulty in HCl , but rapidly with addition of KClO_3 . The hydroxide, $\text{Co}(\text{OH})_2$, precipitates on adding NaOH . This changes from a rose-red color to black on oxidation with H_2O_2 with formation of $\text{Co}(\text{OH})_3$, in which form it is precipitated with the iron group. Upon dissolving the combined precipitates (MnO_2 remaining insoluble), cobalt passes into solution with iron and nickel. It remains in solution when NH_4OH is added in excess and is thus separated from iron, which precipitates as $\text{Fe}(\text{OH})_3$.

By precipitation as sulfide and extraction with dilute N. HCl the CoS and NiS are separated from ZnS , which dissolves. The sulfides of cobalt and nickel are brought into solution with HCl and KClO_3 . These are separated by precipitation of cobalt as the yellow, $\text{K}_3\text{Co}(\text{NO}_2)_6$, by means of KNO_2 ; nickel remains in solution. A small amount of the KNO_2 is first added to avoid danger of also precipitating Ni . If a considerable precipitate forms, KNO_2 reagent is added, together with KCl , to nearly saturate the solution for a more complete precipitation of cobalt as cobaltinitrite. Oxidation of Co^{++} to Co^{+++} takes place during the action. $\text{K}_4\text{Ni}(\text{NO}_2)_6$ is fairly soluble.

Cobalt may also be detected by nitroso-beta-naphthol added to an acid solution; a brick-red precipitate forming in the presence of cobalt.

KCNS produces a red color with cobalt. If to its neutral or faintly acid solution are added twice its volume of alcohol and four times its volume of ether, and the solution shaken, the ether layer is colored blue by the cobalt. If iron is present its effect is destroyed by adding $\text{Na}_2\text{S}_2\text{O}_3$ until the red color disappears, and then filtering and testing the solution for cobalt with the alcohol-ether mixture.

NH_4CNS added to a concentrated cobaltous solution colors it blue. The solution turns pink on dilution.

A borax bead fused with a cobalt salt is colored blue.

2. *Nickel*.—The element forms the complex ion $\text{Ni}(\text{NH}_3)_4^{++}$

when an excess of NH_4OH is added to its solution. The solution is blue, similar in appearance to the solution obtained with $\text{Cu}(\text{NH}_3)_4^{++}$ ions, though less intense. By action of H_2S the sulfide, NiS , precipitates. In presence of $(\text{NH}_4)_2\text{S}_x$ some of the NiS passes into the filtrate, giving a brown solution. If this solution is boiled for a few minutes the NiS precipitates and may be filtered off.

NiS like CoS does not dissolve readily in HCl . Addition of KClO_3 rapidly effects solution. From this solution NaOH precipitates green $\text{Ni}(\text{OH})_2$. This precipitate is readily soluble in HNO_3 . Nickel appears with cobalt and iron in the filtrate from MnO_2 . It remains in solution from the ammoniacal precipitation of iron. Upon reprecipitation of NiS and CoS and resolution of the sulfides with HCl and KClO_3 , on adding KNO_2 nickel remains in solution while cobalt precipitates. From this solution nickel is precipitated by dimethyl glyoxime as the characteristic red nickel glyoxime, according to the detailed procedure given in Table III.

Borax Bead.—Nickel colors the borax bead brown by the fusion test.

Potassium Cyanide added to a slightly alkaline solution of nickel precipitates green $\text{Ni}(\text{CN})_2$, soluble in excess of KCN forming $\text{K}_2\text{Ni}(\text{CN})_4$. This solution heated with bromine water gives a black precipitate of $\text{Ni}(\text{OH})_3$.

Note.—When Na_2O_2 is added in oxidations the solution should be cold and the peroxide added in small amounts at a time, as decomposition will take place with explosive violence if large amounts are added. A hardened filter should be used, since the alkaline solution will attack an ordinary filter, and the organic matter will prevent precipitation of MnO_2 in the filtrate.

3. *Manganese.*—This interesting element of variable character presents itself, in its identification, in three valence forms; in the divalent form when precipitated by H_2S as MnS , the only pink sulfide of the common elements; in the tetravalent form to which it is oxidized by the action of KClO_3 in nitric acid solution, a

black oxide of the formula MnO_2 ; in the heptavalent form $HMnO_4$, highly characteristic of the element.*

Manganese is separated from iron, nickel and cobalt as MnO_2 . This is reduced in nitric acid solution by H_2O_2 to divalent $Mn(NO_3)_2$. We ordinarily think of H_2O_2 as a strong oxidizing agent; in acid solution the compound acts as if it were made up of a molecule of H_2O and an atom of O surcharged with two electrons $-O^-$. Giving up these electrons the ion acts as a reducing element, causing tetravalent Mn^{++++} to be reduced to divalent form Mn^{++} by neutralizing two of its positive charges, oxygen in turn escaping as a gas. Divalent manganese, in nitric acid solution, is oxidized to the heptavalent form in $HMnO_4$ in the cold by BiO_2 or in a hot solution by PbO_2 .

Trace manganese through its transformations from $MnCl_2$ to $HMnO_4$.

In isolating manganese as MnO_2 the precipitate does not form at once on addition of $KClO_3$, but comes down slowly on heating, a change occurring in the color of the solution as the oxidation takes place (HNO_2 that may be present in HNO_3 reduces Mn^{++++} causing the MnO_2 to dissolve).

Filtering through an asbestos filter is necessary, since filter paper would not only be dissolved by action of the strong acid, but this would reduce MnO_2 . If preferred, a Gooch crucible with an asbestos layer at the bottom, may be used in place of the funnel.

After removing the filtrate containing Fe^{+++} , Co^{++} , Ni^{++} , etc., the MnO_2 may be dissolved from the asbestos by passing through this filter about 5 to 10 cc. of hot HNO_3 containing 1-2 cc. H_2O_2 (3 per cent sol.). The BiO_2 test is now made on this solution, adding an excess of the dioxide.

The borax bead with manganese in the oxidizing flame is

* A fourth form Mn^{+++} results by the action of air on $Mn(OH)_2$, namely $MnO(OH)$.

Mn^{++} manganous, Mn^{+++} manganic, Mn^{++++} manganite, Mn^{+++++} manganate, Mn^{++++++} permanganate.

colored an amethyst red, the color disappears in the reducing flame.

Fused with Na_2CO_3 and NaNO_3 , manganese compounds produce a green colored mass.

4. *Iron*.—The divalent and trivalent forms of iron are met with in the isolation of iron. Upon expulsion of H_2S , iron is present in the solution in ferrous form, some oxidation takes place upon boiling the solution, so that the precipitate is a mixture of $\text{Fe}(\text{OH})_2$ and $\text{Fe}(\text{OH})_3$. $\text{Fe}(\text{OH})_2$ is soluble in presence of NH_4Cl , $\text{Fe}(\text{OH})_3$ is insoluble. The action of HCl and KClO_3 oxidizes the iron to ferric form so that it is precipitated from the solution by NaOH as $\text{Fe}(\text{OH})_3$.

The HNO_3 action convert $\text{Fe}(\text{OH})_3$ to $\text{Fe}(\text{NO}_3)_3$. Iron hydroxide is precipitated from this solution by NH_4OH , and in acid solution is further identified by testing with KCNS (red color) or $\text{K}_4\text{Fe}(\text{CN})_6$ (blue color). Should $-\text{PO}_4$ be present the precipitate of iron may be white FePO_4 . Iron is tested for in a small portion of the material and the $\text{PO}_4^{=}$ removed as outlined in the special directions following Table III (5a). The basic ferric acetate carries down all of the $-\text{PO}_4^{=}$, provided the Fe^{+++} is in slight excess. This is evident from the red color of the precipitate produced. The bivalent elements are left in solution. A large excess of FeCl_3 is avoided since it has a solvent action on the precipitate.

5. *Aluminum*.—When the alkaline solution is acidified with HCl , the NaAlO_2 is converted to AlCl_3 and NaCl . (Write the reaction.) The addition of NH_4OH converts the aluminum salt to $\text{Al}(\text{OH})_3$, the hydroxide precipitating. A large excess of NH_4OH is avoided, as it would form the soluble NH_4AlO_2 . If present in the solution, lead, antimony, tin and silicon may precipitate with aluminum. H_2SiO_3 is very apt to be present and it would be mistaken for $\text{Al}(\text{OH})_3$. (NaOH and Na_2O_2 are very apt to contain Na_2SiO_3 , so that a confirmatory test for aluminum is necessary.)

Two methods are recommended for confirmation of aluminum, the cobalt nitrate test and the aluminon test, either of these being conclusive. The nitrate test is sensitive to about 0.2 mg. The ash produced is a blue color, but should the cobalt be present in excess, the black oxide of cobalt will obscure the blue, hence care must be exercised in adding only a few drops of the reagent, the amount being governed by the size of the precipitate obtained. 1-10 drops with 10-100 mg. Al.

The aluminon ($\text{H}_3\text{C}_{22}\text{H}_{13}\text{O}_8$) test for aluminum is that of Hammett and Sottery (J. Am. Chem. Soc., 47, 142) details of which appear in the preliminary test F5. The $\text{Al}(\text{OH})_3$ is dissolved in 5 cc. N. HCl. 5 cc. 3N. $\text{NH}_4\text{C}_2\text{H}_3\text{O}_2$ and 5 cc. of 0.5 per cent solution of the ammonium salt of the dye are added and the solution made alkaline with NH_4OH containing $(\text{NH}_4)_2\text{CO}_3$. Aluminum produces a red colored precipitate on standing, the $\text{Al}(\text{OH})_3$ occluding the dye, aurin tricarboxylic acid.

6. *Chromium*.—Of the three forms in which chromium is commonly found, divalent, trivalent, and hexavalent, the two latter are of interest in our analytical procedure. The element forms many compounds, most of these have a color (chroma-color). The hydrated chromous salts are generally blue, the acetate red, the hydroxide yellow. The chromic salts of trivalent chromium vary in color, since these may be pink, violet and grayish green. The green hydroxide is met with in our analysis, as this is the form in which chromium is first isolated. Hexavalent chromium forms chromates and dichromates, yellow and orange colored salts. The chromates are obtained by oxidation, in our analysis, by the addition of peroxide in alkaline solution. In acid solution, H_2O_2 reduces a chromate to chromic form. Care is exercised to avoid heating upon acidification of the aluminum group, for should the chromate be reduced it will precipitate with aluminum as $\text{Cr}(\text{OH})_3$.

The yellow color produced by a chromate or dichromate (orange) is characteristic; a yellow color is obtained in alkaline solution due to the formation of a chromate and an orange color

in acid solution due to the formation of a dichromate. Look up the chapter on chromium in your text book on inorganic chemistry regarding these two forms and note the reactions for converting one to the other by treating with acid or alkali.

The use of lead acetate for precipitation of the chromate is preferable to barium acetate. Sulfate ions are apt to be present, causing the precipitation of BaSO_4 with the chromate. On the other hand, in a hot solution and in presence of ammonium acetate, PbSO_4 would not form.

The confirmatory test with ether and H_2O_2 is interesting but superfluous. The blue colored compound is probably perchromic acid. Authorities disagree as to the composition of the compound. HCrO_4 , HCrO_5 , H_3CrO_7 are given as its formula.

Chromates may be reduced by H_2S , SO_2 , alcohol and ferrous salt to chromic form.

Diphenyl Carbizide, $\text{CO}(\text{NH.NH.C}_6\text{H}_5)_2$, added to a faintly acid (HCl or $\text{H.C}_2\text{H}_3\text{O}_2$) solution, produces a violet pink color. Less than 0.0000001 gr. Cr may be detected. The reagent is made by dissolving 0.2 g. of the compound in 5 cc. of glacial acetic acid and diluting to 20 cc. with ethyl alcohol.

7. *Zinc*.—The element has been mentioned in connection with the iron group. It is often found with the iron group, especially if the hydroxide precipitate of this group is large. The hydroxide of zinc, $\text{Zn}(\text{OH})_2$, like the hydroxides of aluminum and chromium, dissolves in an excess of NaOH to form a sodium salt soluble in water. The Na_2ZnO_2 passes into solution (unless occluded by $\text{Fe}(\text{OH})_3$, etc.) and is found with Al and Cr.

a. When the aluminum is precipitated with NH_4OH , in slight excess, the zinc remains in solution with chromium. It is separated from chromium by decomposing the $\text{Zn}(\text{NH}_3)_4^{++}$ ion by concentrating with Na_2CO_3 , with expulsion of NH_3 . The precipitate is a mixture of the carbonate and hydroxide.

The precipitate is decomposed by HCl with formation of ZnCl_2 . Zinc is now precipitated from ammoniacal solution as

ZnS. Free sulfur may mislead conclusions by forming a cloudy solution. Furthermore the presence of a contaminating element make it necessary to carry out the confirmatory fusion test with cobalt nitrate. An excess of cobalt reagent should be avoided as this would mask the green color due to the zinc cobalt compound.

b. Optional Method for Detection of Zinc.—W. H. Cone and L. C. Cady (J. Am. Chem. Soc., Sept., 1927) give an optional method for detection of zinc which they claim to be superior to the fusion method given above. The method follows:

To the filtrate from the aluminum hydroxide precipitate add acetic acid until the solution reddens litmus paper. Divide in two portions. Test one portion for chromium, and the other for zinc as follows: Add five drops of diphenylamine acetate solution (1 g. diphenylamine dissolved in 100 cc. of glacial acetic acid) and 5 cc. of 0.5 per cent potassium ferricyanide solution. A dark brown, greenish to purplish-black turbidity indicates the presence of zinc.

Test for zinc in the iron group. Boil the hydrochloric acid solution from the cobalt nickel sulfide treatment with the acid until H_2S is expelled, make alkaline with NaOH solution and add one gram of sodium peroxide, in small portions, with stirring. Decompose the peroxide by boiling, cool and filter. Acidify the filtrate with acetic acid and make the diphenylamine-ferricyanide test stated in the optional method for detecting zinc.

CLASSROOM REVIEW OF THE AMMONIUM-SULFIDE GROUP

1. Would the alkaline earth elements be found in the filtrate from the ammonium hydroxide precipitate, obtained by making the solution basic, if $-\text{PO}_4^{\equiv}$ were present in considerable excess of that required in reacting with iron?
2. If $-\text{PO}_4^{\equiv}$ were present in the solution and no precipitate formed on making the solution alkaline with NH_4OH , would you look for the alkaline earths in the unknown solution?
3. Explain by using the principle of the solubility product, the reason for the removal of $-\text{PO}_4^{\equiv}$ ions from solution by Fe^{+++} ions, in presence of bivalent elements.
4. What reactions are common to all the members of the ammonium-sulfide group?
5. What would happen if CO_2 were absorbed by the NH_4OH reagent used for making the iron and aluminum divisions alkaline?
6. Account for the formation of $\text{Al}(\text{OH})_3$ and $\text{Cr}(\text{OH})_3$ when the sulfides are placed in water.
7. Why does a solution of $\text{K}_4\text{Fe}(\text{CN})_6$ fail to give the ordinary tests for iron? How would you test for Fe^{+++} in $\text{K}_4\text{Fe}(\text{CN})_6$?
8. How are the sulfides of cobalt and nickel separated from ZnS ?
9. How are the hydroxides of manganese and iron separated?
10. How would you distinguish a ferrous from a ferric salt?
11. How would you distinguish hexavalent chromium in solution from trivalent chromium?
12. What is the purpose of the peroxide in Table III, step 3A?
13. What elements of the ammonium-sulfide group are soluble in an excess of NH_4OH in presence of NH_4Cl ?
14. Which of the hydroxides remain unchanged on the addition of H_2S or $(\text{NH}_4)_2\text{S}$ in the precipitation of the ammonium-sulfide group?
15. Give an example of mass action in the analysis of the ammonium-sulfide group?
16. How is adsorption illustrated in the confirmatory test for aluminum?
17. Name two organic reagents used in confirmatory test of elements of the ammonium-sulfide group. What are the formulae of the compounds formed in these confirmatory tests?
18. Be prepared to trace an element of the ammonium-sulfide group through all the steps used in its separation and confirmation.
19. Be prepared to write the equations of the reactions involved with the various elements studied in this group.
20. Cobalt nitrate is used in the confirmatory tests for what elements? What are the colors of the fusions? Why is it necessary to avoid an excess of the cobalt nitrate?
21. Complete and balance the following equations:

Group Reactions—Ammonium-Sulfide Group

- (1) $\text{FeCl}_3 \cdot \text{FeCl}_2 + \text{NH}_4\text{OH} = \text{Fe}(\text{OH})_{2-3} +$
- (2) $\text{FeCl}_2 + \text{H}_2\text{S} = \text{FeS} +$
- (3) $\text{FeS} + \text{HCl} = \text{FeCl}_2 +$
- (4) $\text{FeCl}_2 + \text{Cl}_2 = \text{FeCl}_3 +$
- (5) $\text{FeCl}_3 + \text{NaOH} = \text{Fe}(\text{OH})_3 +$
- (6) $\text{FeCl}_3 + \text{K}_4\text{Fe}(\text{CN})_6 + \text{HCl} = \text{Fe}_4(\text{Fe}(\text{CN})_6)_3 +$
- (7) $\text{FeCl}_3 + \text{KCNS} = \text{Fe}(\text{CNS})_3 +$
- (8) $\text{MnCl}_2 + \text{H}_2\text{S} = \text{MnS} +$
- (9) $\text{MnS} + \text{HCl} = \text{MnCl}_2 +$
- (10) $\text{MnCl}_2 + \text{NaOH} = \text{Mn}(\text{OH})_2 +$
- (11) $\text{Mn}(\text{OH})_2 + \text{Na}_2\text{O}_2 = \text{MnO}(\text{OH})_2 +$
- (12) $\text{MnO}_2 + \text{HNO}_3 + \text{H}_2\text{O}_2 = \text{Mn}(\text{NO}_3)_2 + \text{O}_2 + \text{H}_2\text{O}$
- (13) $\text{Mn}(\text{NO}_3)_2 + \text{BiO}_2 + \text{HNO}_3 = \text{HMnO}_4 + \text{Bi}(\text{NO}_3)_3 +$
- (14) $\text{NiCl}_2 + \text{H}_2\text{S} = \text{NiS} +$
- (15) $\text{NiS} + \text{HCl} = \text{NiCl}_2$
- (16) $\text{NiCl}_2 + \text{NH}_4\text{OH} = \text{Ni}(\text{NH}_3)_4\text{Cl}_2 +$
- (17) $\text{Ni}(\text{NH}_3)_4\text{Cl}_2 + \text{H}_2\text{S} + \text{H}_2\text{O} = \text{NiS} + \text{NH}_4\text{Cl} + \text{NH}_4\text{OH}$
- (18) $\text{NiCl}_2 + (\text{CH}_3)_2\text{C}_2\text{N}_2\text{O}_2\text{H}_2 = ((\text{CH}_3)_2\text{C}_2\text{N}_2\text{O}_2\text{H})_2\text{Ni} +$
- (19) $\text{CoCl}_2 + \text{H}_2\text{S} = \text{CoS} +$
- (20) $\text{CoS} + \text{HCl} = \text{CoCl}_2 +$
- (21) $\text{CoCl}_2 + \text{NaOH} = \text{Co}(\text{OH})_2 +$
- (22) $\text{Co}(\text{NH}_3)_4\text{Cl}_2 + \text{H}_2\text{S} = \text{CoS} +$
- (23) $\text{CoCl}_2 + \text{KNO}_2 + \text{HC}_2\text{H}_3\text{O}_2 = \text{K}_3\text{Co}(\text{NO}_2)_6 + \text{NO} + \text{etc.}$
- (24) $\text{AlCl}_3 + \text{H}_2\text{S} + \text{NH}_4\text{OH} = \text{Al}(\text{OH})_3 +$
- (25) $\text{AlCl}_3 + \text{NH}_4\text{OH} = \text{Al}(\text{OH})_3 +$
- (26) $\text{Al}(\text{OH})_3 + \text{HCl} = \text{AlCl}_3 +$
- (27) $\text{Al}(\text{OH})_3 + \text{NaOH} = \text{NaAlO}_2 +$
- (28) $\text{NaAlO}_2 + \text{HCl} = \text{AlCl}_3 +$
- (29) $\text{CrCl}_3 + \text{NH}_4\text{OH} = \text{Cr}(\text{OH})_3 +$
- (30) $\text{CrCl}_3 + \text{H}_2\text{S} + \text{NH}_4\text{OH} = \text{Cr}(\text{OH})_3 +$
- (31) $\text{Cr}(\text{OH})_3 + \text{NaOH} = \text{NaCrO}_2 +$
- (32) $\text{CrCl}_3 + \text{NaOH} + \text{H}_2\text{O}_2 = \text{Na}_2\text{CrO}_4 + \text{NaCl} + \text{H}_2\text{O}$
- (33) $\text{Na}_2\text{CrO}_4 + \text{HCl} = \text{Na}_2\text{Cr}_2\text{O}_7 + \text{NaCl} + \text{H}_2\text{O}$
- (34) $\text{Na}_2\text{Cr}_2\text{O}_7 + \text{Pb}(\text{C}_2\text{H}_3\text{O}_2)_2 + \text{H}_2\text{O} = \text{PbCrO}_4 +$
- (35) $\text{ZnCl}_2 + \text{H}_2\text{S} = \text{ZnS} +$
- (36) $\text{ZnCl}_2 + \text{NH}_4\text{OH} = \text{Zn}(\text{NH}_3)_4\text{Cl}_2 +$
- (37) $\text{ZnS} + \text{HCl} = \text{ZnCl}_2 +$
- (38) $\text{ZnCl}_2 + \text{NaOH} = \text{Zn}(\text{OH})_2 +$
- (39) $\text{Zn}(\text{OH})_2 + \text{NaOH} = \text{Na}_2\text{ZnO}_2 +$
- (40) $\text{Na}_2\text{ZnO}_2 + \text{HCl} = \text{ZnCl}_2 +$
- (41) $\text{ZnCl}_2 + (\text{NH}_4)_2\text{S} = \text{ZnS} +$

AMMONIUM-CARBONATE GROUP—THE ALKALINE EARTHS

Barium, Calcium, Strontium

In alkaline solutions the members of this group are precipitated as carbonates by ammonium carbonate in presence of ammonium chloride. The solubility of magnesium in presence of ammonium chloride places it with the soluble group.

PRELIMINARY TESTS

§ 26. *A. Separations.*—1. In separate, marked containers place 5 cc. of test solutions containing barium, strontium, calcium and magnesium. Make slightly alkaline with NH_4OH . Do any precipitates form? Add to each solution a few drops of $(\text{NH}_4)_2\text{CO}_3$ and observe that precipitation takes place in each case.

Solubilities per 100 cc. of water at 18° : BaCO_3 2 mg., SrCO_3 1 mg., CaCO_3 1 mg., MgCO_3 95 mg.

2. To each solution with its precipitate add 5 cc. of NH_4Cl reagent. Magnesium carbonate dissolves. Reject.



3. Heat each solution with its precipitate and observe that the precipitates coagulate and settle. Carefully decant the supernatant solutions from the precipitates, leaving the precipitates in the containers and rejecting the solutions. Add to each precipitate 5 cc. of dilute acetic acid and observe that all of these dissolve. Write the reactions.

4. Add to each acetate solution 5 cc. of $\text{K}_2\text{Cr}_2\text{O}_7$ reagent. Observe that precipitation takes place with barium alone, yellow BaCrO_4 being formed. This insolubility of BaCrO_4 affords a

means of separation of barium from strontium and calcium. Consult the table of separation that follows:

5. Dilute the chromate solutions of strontium and calcium with four times their volumes of alcohol (C_2H_5OH) and observe that $SrCrO_4$ precipitates, while calcium remains in solution. This insolubility of $SrCrO_4$ in alcohol serves as a method for separating strontium from calcium.

6. Take two fresh 5 cc. portions of strontium and calcium test solutions in separate beakers and make each slightly alkaline with NH_4OH (litmus paper test). Dilute each with an equal volume of water and add 5 cc. of $(NH_4)_2SO_4$ reagent. Warm gently. Observe that $SrSO_4$ precipitates. Study the table for the solubility of $BaSO_4$, $SrSO_4$ and $CaSO_4$.

B. Confirmatory Tests.—1. *Barium.*—The acetic acid insoluble $BaCrO_4$, yellow precipitate obtained in A4 is generally a sufficient test for barium. Barium may be further confirmed by dissolving the precipitate in a few drops of dilute HCl and then adding a few drops of dilute H_2SO_4 (any water soluble sulfate will do), a white precipitate of $BaSO_4$ will be obtained in presence of barium.

Note.—The appearance of the $BaSO_4$ is reddish-yellow due to the color of $Cr_2O_7^{--}$. The white color of $BaSO_4$ becomes evident on removal of the solution from the precipitate.

Flame test.—A platinum wire attached to a glass rod is used for flame tests. The free end of the wire has a small loop to hold a drop of the liquid to be tested. The wire should be clean as traces of impurities will interfere with the tests. The wire may be cleaned mechanically and then dipped in concentrated HCl and held in the flame, repeating the HCl treatment and heating until no color is imparted to the flame. The loop is now dipped into the barium solution, preferably a chloride, and held in the flame. Barium colors the flame a yellowish green.

2. *Strontium.*—The tests given in A5 and 6 are characteristic of strontium. Strontium will precipitate as $SrSO_4$ when a satu-

rated solution of soluble strontium salt is mixed with a saturated solution of CaSO_4 .

Flame test.—Strontium imparts a bright red color to the flame.

3. *Calcium*.—A solution of a soluble oxalate, such as ammonium oxalate added to a solution containing calcium will precipitate white CaC_2O_4 . Compare the solubilities of the oxalates of barium, strontium and calcium in the table of solubilities that follows.

Flame Test.—Calcium imparts an orange red color to the flame.

Test in a HCl solution.

TABLE OF SOLUBILITIES (in g.)

100 Cc. Water at 18° C.

	Cl	NO_3	SO_4	CrO_4	C_2O_4	CO_3	OH
Ca.....	72.5	121.0	0.202	2.34	0.0005	0.001	0.167
Sr.....	52.8	67.6	0.011	0.12	0.004	0.001	0.78
Ba.....	35.2	8.8	0.0002	0.0003	0.008	0.002	3.58
Mg.....	54.1	72.2	34.6	72.3	0.03	0.095	0.0008

C. Make a composite solution containing 5 cc. portions of the test solutions of barium, strontium and calcium. Separate and identify each of the elements according to the directions given in the outline of separations that follows.

D. Get an "unknown" containing the members of the group and separate and identify the members of the group that may be present.

Study the notes that follow the table of separations.

§ 27

TABLE IV

SEPARATION OF THE AMMONIUM-CARBONATE GROUP—
THE ALKALINE EARTHS

1. The solution from the Ammonium-Sulfide group is taken for this analysis. Ammonium chloride should be present, if it is not, add 5 cc. of a 25 per cent solution.

Concentrate the solution to 10–15 cc. Filter off the sulfides and free sulfur. Refilter if not clear. Wash with 4–5 cc. of water and save the filtrate for examination of the Ammonium-Carbonate group. Reject the residue.

Add NH_4OH until the solution colors red litmus paper blue. Heat to boiling and add slowly sufficient $(\text{NH}_4)_2\text{CO}_3$ to completely precipitate the members of the group, 10 to 15 cc. of the reagent generally is sufficient. Warm (do not boil) for several minutes. Filter, saving the filtrate for the examination of the Soluble group. The precipitate contains the $(\text{NH}_4)_2\text{CO}_3$ group. Wash with a little water containing some of the precipitating reagent. Reject the washings.

Precipitate.— BaCO_3 , SrCO_3 , CaCO_3 , white.

Filtrate.—Mg, Na, K, etc.

2. *Isolation of Barium.*—Dissolve the precipitate by pouring over it 5–10 cc. of hot dilute acetic acid, passing the acid back over the filter if any precipitate remains undissolved. Wash the filter with 5–10 cc. of water combining the washing with the filtrate. Make barely alkaline with NH_4OH (litmus paper test), now again acidify with acetic acid, adding 2 cc. excess. Test a small portion of the filtrate with a few drops of $\text{K}_2\text{Cr}_2\text{O}_7$ reagent and observe if a precipitate forms on allowing to stand a minute or so. If not, barium is absent and step 3 may be omitted. If the test is negative continue with the main solution by step 5, omitting addition of $\text{K}_2\text{Cr}_2\text{O}_7$ and rejecting the small tested sample. Should a precipitate form treat the remainder of the solution as follows:

To main bulk of the solution, heated to boiling, add $\text{K}_2\text{Cr}_2\text{O}_7$ reagent drop by drop, until the precipitation is complete and the solution appears an orange color when the BaCrO_4 has settled. Avoid a large excess of the reagent. 5–6 cc. of the reagent are generally sufficient. Filter, saving the filtrate for calcium and strontium tests, and the precipitate for confirmation of barium. Wash the precipitate with a few cubic centimeters of water, rejecting the washings.

Precipitate.— BaCrO_4 yellow.

Solution.—Strontium, Calcium.

3. *Confirmatory test for Barium.*—Dissolve the precipitate in warm HCl . Confirm barium by one of the following tests: (a) Add a few drops of H_2SO_4 . A white precipitate is BaSO_4 . (b) Add NH_4OH until the orange color changes to yellow. Add a few drops of $\text{K}_2\text{Cr}_2\text{O}_7$ reagent. A yellow precipitate is BaCrO_4 . (c) Make a flame test for barium. The flame is colored green by Barium.

4. If chromate is present it is removed as follows: Add NH_4OH until the solution turns yellow and the solution is alkaline to litmus paper. Heat to boiling and add 5–10 cc. of $(\text{NH}_4)_2\text{CO}_3$ reagent. Allow to stand for a few minutes and filter. Wash free of yellow chromate and reject the solution. Continue with the precipitate according to step 5.

See also separation of strontium as SrCrO_4 in alcohol solution in preliminary tests and in the summary under strontium.

 5. *Separation and Detection of Strontium and Calcium.*

Dissolve the precipitate on the filter with 5-6 cc. of dilute acetic acid, pouring the acid back over the filter, if a white residue remains. (Yellow BaCrO_4 will remain undissolved should it be present.)

In case step 4 was omitted, owing to the absence of barium in the solution making it unnecessary to use $\text{K}_2\text{Cr}_2\text{O}_7$ reagent, the above step is also omitted.

Make the acetic acid solution slightly alkaline by addition of NH_4OH , drop by drop, until the solution turns red litmus paper blue.

*Isolation of Strontium.**—To the alkaline solution add about 5 cc. of ammonium sulfate reagent. Allow to stand a few minutes and filter. Save the precipitate for a confirmatory test of strontium. Test for calcium in the filtrate.

Precipitate.— $\text{SrSO}_4(\text{CaSO}_4)$ white.

6. *Confirmatory Test for Strontium.*
—Dissolve the precipitate in HCl and by means of a platinum wire make the flame test. The flame is colored red by Strontium.

Note.—Small amounts of barium escaping precipitation with $\text{K}_2\text{Cr}_2\text{O}_7$ reagent would be precipitated by $(\text{NH}_4)_2\text{SO}_4$ as white BaSO_4 , hence the confirmatory test for strontium is advisable.

Filtrate.— CaSO_4 .

7. *Test for Calcium.*—To the ammoniacal solution add 5-10 cc. of ammonium oxalate reagent, $(\text{NH}_4)_2\text{C}_2\text{O}_4$, and heat gently. A white precipitate, insoluble in dilute acetic acid proves the presence of Calcium. (CaC_2O_4 .)

Confirm.

Dissolve the precipitate in HCl and make a flame test of the chloride. The flame is colored orange yellow.

* CaSO_4 Test.

CHART IV

AMMONIUM-CARBONATE GROUP, THE ALKALINE EARTHS

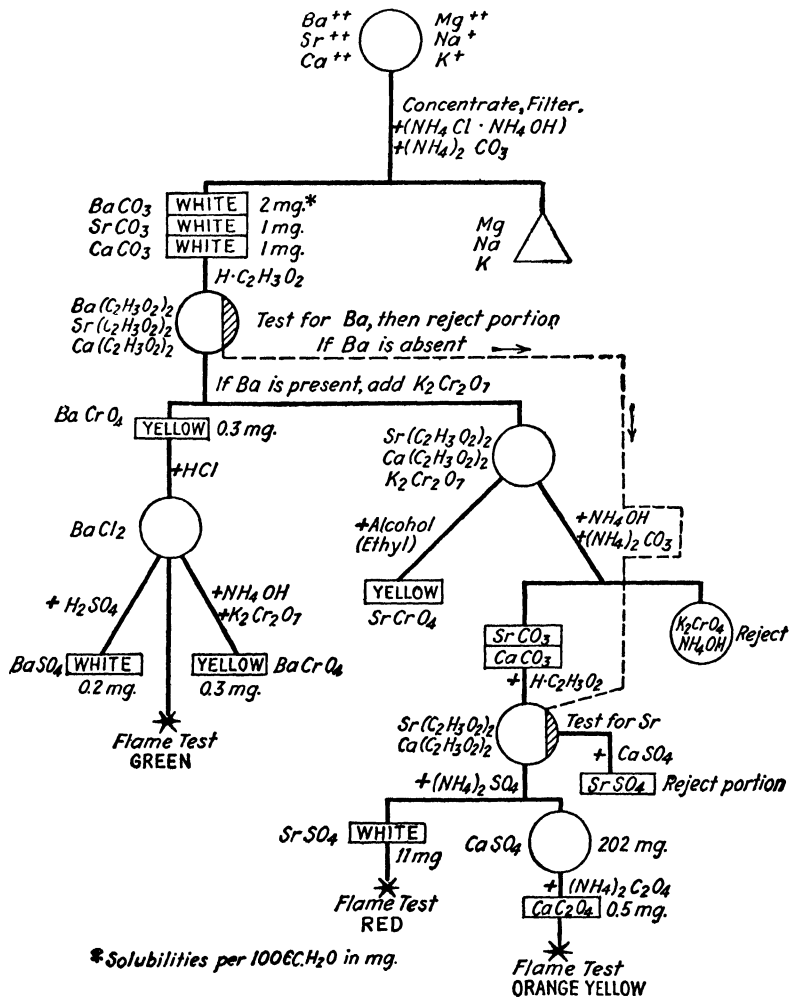

SUMMARY AND CHEMICAL PRINCIPLES— AMMONIUM-CARBONATE GROUP

§ 28. In the general procedure, if the solution examined is the filtrate from the ammonium-sulfide group, a sufficient amount of ammonium chloride will be present to prevent the precipitation of MgCO_3 , when the group reagent $(\text{NH}_4)_2\text{CO}_3$ is added. In an original solution it will be necessary to add NH_4Cl and NH_4OH , before adding $(\text{NH}_4)_2\text{CO}_3$.

Magnesium and the alkalis pass into the filtrate from the alkaline earth carbonate precipitates.

Before addition of the group reagent, if the solution is the filtrate from the previous groups, it is necessary to boil down to a small volume to precipitate the sulfur and the sulfides that may have escaped precipitation in the ammonium-sulfide group. There is some danger of SO_4 forming, resulting in the precipitation of BaSO_4 which is lost. Loss of strontium and calcium also takes place, so that the amounts of Ba, Sr and Ca may be small in the filtrate from previous separations. It may be necessary to test for these in the original material.

Traces of barium, calcium and strontium may pass into the soluble group.

1. *Barium*.—This divalent element has the highest atomic weight of the three members. Although its carbonate and oxalate are the most soluble of the three, its chromate salt and its sulfate are the least soluble. Advantage is taken of the low solubility of Ba_2CrO_4 in separating barium from strontium and calcium. The strontium chromate is 400 times as soluble, and the calcium chromate nearly 8000 times as soluble at 18°C .

Three confirmatory tests of barium are given: (a) Reprecipitation of BaCrO_4 after dissolving in HCl and neutralizing the acid with NH_4OH ; (b) Precipitation of difficultly soluble BaSO_4 ,

from the HCl solution of BaCrO_4 (see comparative solubilities of BaSO_4 , SrSO_4 and CaSO_4) and (c) Flame test of the HCl solution; the flame is colored green by barium. Three characteristic green bands are seen by means of the spectroscope.

Saturated solutions of SrSO_4 or CaSO_4 added to solutions of barium will precipitate BaSO_4 , due to the extreme insolubility of this salt.

BaSO_4 is soluble in hot concentrated H_2SO_4 . By double decomposition it may be converted to BaCO_3 and Na_2SO_4 by boiling with a concentrated solution of Na_2CO_3 . Na_2SO_4 being soluble in water may be washed out.

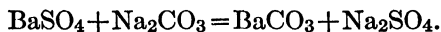

2. *Strontium*.—The divalent element has an atomic weight intermediate between barium and calcium. Although its carbonate has about the same solubility as that of calcium, its sulfate is about half as soluble as CaSO_4 , hence it may be precipitated from a concentrated solution by a saturated solution of CaSO_4 . Strontium chromate is difficultly soluble in alcohol of about 50 per cent strength while the chromate of calcium is fairly soluble. Advantage may be taken of this fact in separating strontium from calcium.

Flame tests of strontium and calcium are generally advisable due to the fact that the solubilities of the sulfate or chromate salts afford only a partial separation. The chromate of calcium is about 20 times as soluble as that of strontium. The optional method for the separation of strontium chromate from calcium chromate is as follows:

Ethyl Alcohol Method for Separating Strontium Chromate from Calcium Chromate.—The filtrate from BaCrO_4 , containing $\text{K}_2\text{Cr}_2\text{O}_7$ reagent in sufficient excess, is treated with an equal volume of ethyl alcohol (additional $\text{K}_2\text{Cr}_2\text{O}_7$ may be required to furnish the necessary CrO_4^{2-} ion concentration to exceed the solubility product of SrCrO_4). The SrCrO_4 , that precipitates, is filtered off. Some calcium may be present. The precipitate is dissolved in hot water, ammonium carbonate and oxalate are added and the correspond-

ing SrCO_3 , and CaC_2O_4 precipitated. (N.B. solubilities in the table following the preliminary tests.) Strontium is brought into solution by adding dilute acetic acid, in which CaC_2O_4 is insoluble. Strontium may be precipitated as SrSO_4 from this solution by adding $(\text{NH}_4)_2\text{SO}_4$. Strontium may be tested for by the flame test in this extract by converting it to SrCO_3 in an ammoniacal solution, and then to SrCl_2 .

Strontium gives a brilliant red flame, calcium produces an orange-yellow colored flame. Examination by means of the spectroscope shows eight bright bands: 6 are red, 1 orange, 1 blue. Calcium on the other hand has an intense orange and green line, with a less distinct violet line.

3. *Calcium*.—This divalent element has the lowest atomic weight of the three common elements studied in this group. Calcium carbonate has about the same solubility as that of strontium. The sulfate is about twice as soluble as that of strontium and the chromate about 20 times as soluble. The oxalate of calcium is about $\frac{1}{10}$ as soluble as strontium oxalate and $\frac{1}{20}$ as soluble as barium oxalate; facts made use of in the confirmation of calcium. Final confirmation of calcium by the flame test has been mentioned.

In making the flame tests, a platinum wire embedded in a glass rod is used. The wire has a small loop at the free end. It is dipped in strong HCl and held in the blue flame of the Bunsen burner. If a color is imparted to the flame, it is again dipped into pure HCl (never into the reagent bottle) in a clean beaker, and again held in the flame. This is repeated until the platinum imparts no color to the flame. It may be necessary to clean the wire mechanically with sand to free it from adhering substances. Tests are made with the cleaned wire by dipping it in the solution to be tested and then holding in the flame. The characteristic colors do not appear at the same time, owing to the difference in the volatility of the chloride of barium, strontium and calcium. Examination of the flame by means of the spectroscope establishes with certainty traces of these elements. HCl solutions are best.

§ 29

CLASSROOM REVIEW OF THE AMMONIUM-CARBONATE GROUP

1. Why would $(\text{NH}_4)\text{HCO}_3$ be unsuitable for precipitating this group? What chemical laws are illustrated in the tests of the members of this group? Give examples.

2. Why is the second chromate precipitation of barium a better evidence of its presence than the first precipitation? See test (b) of the table of separations.

3. Why should the solution be alkaline, and why should NH_4Cl be present in the precipitation of this group?

4. What reactions are common to the members of the ammonium-carbonate group?

5. Give a method by which each member may be extracted from its sulfate mineral.

6. Trace the changes that take place with each element in its isolation and detection by the wet methods.

7. In equimolar solutions of strontium chloride, calcium chloride, sodium carbonate and sodium oxalate, what compounds would result if the solutions were combined?

8. Explain the solubility of calcium, barium and strontium carbonates in acetic acid.

9. Why are the chloride salts of barium, strontium and calcium desirable in the flame tests? Describe how flame tests are made.

10. Why is not the ammonium-sulfate precipitation of strontium a confirmatory test for this element?

11. Explain why calcium oxalate precipitates in presence of acetic acid, but not in presence of sulfuric acid.

12. Complete and balance the following equations:

Group Reactions

- (a) $\text{BaCl}_2 + (\text{NH}_4)_2\text{CO}_3 = \text{BaCO}_3 +$
 (b) $\text{Ba}(\text{C}_2\text{H}_3\text{O}_2)_2 + \text{K}_2\text{CrO}_4 = \text{BaCrO}_4 +$
 (c) $\text{BaCl}_2 + \text{H}_2\text{SO}_4 = \text{BaSO}_4 +$
 (d) $\text{CaCl}_2 + (\text{NH}_4)_2\text{CO}_3 = \text{CaCO}_3 +$
 (e) $\text{CaCO}_3 + \text{H}_2\text{C}_2\text{H}_3\text{O}_2 = \text{Ca}(\text{C}_2\text{H}_3\text{O}_2)_2 +$
 (f) $\text{Ca}(\text{C}_2\text{H}_3\text{O}_2)_2 + (\text{NH}_4)_2\text{C}_2\text{O}_4 = \text{CaC}_2\text{O}_4 +$
 (g) $\text{SrCl}_2 + (\text{NH}_4)_2\text{CO}_3 = \text{SrCO}_3 +$
 (h) $\text{Sr}(\text{C}_2\text{H}_3\text{O}_2)_2 + (\text{NH}_4)_2\text{SO}_4 = \text{SrSO}_4 +$
 (i) $\text{Sr}(\text{C}_2\text{H}_3\text{O}_2)_2 + \text{CaSO}_4 = \text{SrSO}_4 +$

THE SOLUBLE GROUP—MAGNESIUM AND THE ALKALIES

The members of this group are not precipitated by a common group reagent. Their chlorides, sulfides and carbonates are soluble in water under the conditions for the precipitation of previous groups.

PRELIMINARY TESTS

§ 30. 1. *Detection of Magnesium.*—In three separate, small beakers, that are labeled, place 5 cc. portions of test solutions containing magnesium, potassium and sodium respectively. Add to each about 2 cc. NH_4Cl reagent, followed by about 2 cc. of NH_4OH (d. 0.90) and 2 cc. of $(\text{NH}_4)_2\text{HPO}_4$. Shake each mixture and observe that precipitation takes place in the magnesium solution alone. The precipitate is MgNH_4PO_4 , white.

Note.—In mixtures of Mg, K, Na, magnesium is tested for in a separate portion of the solution by precipitation as magnesium ammonium phosphate, according to the procedure in Table V. It is removed from the remainder of the solution according to directions in Table V, before testing for potassium and sodium.

If NH_4Cl is present the diammonium hydrogen phosphate reagent will precipitate from saturated solutions in absence of magnesium. Dilution with water will dissolve this, while the MgNH_4PO_4 remains insoluble.

*Optional Test with O-p-dihydroxymonazo-p-nitrobenzene.**—The organic reagent added to a dilute solution containing Mg^{++} produces a sky-blue precipitate. The solution is made slightly acid by addition of HCl. To the solution a drop of the reagent is added. This is now made alkaline with NaOH. The blue lake forms in presence of magnesium.

Al, Mn, Ba, Ca, Sr do not give the test. NH_4 must be removed. Ni and Co precipitate but give a different shade from that of Mg^{++} lake.

2. *Detection of Potassium.—Sodium Cobaltinitrite Test.*—To a fresh portion of potassium test solution (5 cc.) add 2–3 drops of acetic acid and then an equal volume (5–6 cc.) of $\text{Na}_3\text{Co}(\text{NO}_2)_6$ reagent. Allow to stand a few minutes. A yellow precipitate, $\text{K}_2\text{NaCo}(\text{NO}_2)_6$, will form.

* Test of Suitsu and Okuma, Chem. Abstracts, 20, 300, 1926.

Note.—This test cannot be applied if NH_4 is present as this also gives a yellow precipitate.

3. *Perchlorate Test.*—To a second portion (5 cc.) of potassium test solution in a small beaker add 4–5 cc. of HClO_4 . Evaporate to fumes. Cool thoroughly and add 15–20 cc. 95 per cent ethyl alcohol. (Caution—hot alcohol and HClO_4 are explosive.) A white crystalline precipitate is KClO_4 . Repeat the test with sodium solution and observe that no precipitate forms. Pass in HCl gas and observe that NaCl precipitates. From the perchlorate test suggest a method of separating potassium and sodium.

4. *Sodium-Potassium Dihydrogen Antimonate Test.*—To a 5 cc. portion of sodium test solution in a test tube (the solution should be neutral or slightly alkaline with KOH) add an equal volume of $\text{K}_2\text{H}_2\text{Sb}_2\text{O}_7$, shake vigorously and allow to stand for some time. The crystalline precipitate is $\text{Na}_2\text{H}_2\text{Sb}_2\text{O}_7$.

5. *Flame Tests.*—Make flame tests of potassium and sodium solutions containing a little HCl , using platinum wire with loop. The potassium salt gives a violet colored flame, the sodium salt a yellow flame. Should the potassium color be masked by a yellow color due to sodium contamination, observe the flame, looking through one or more sheets of blue cobalt glass, which cuts out the sodium yellow, enabling the violet color to be seen.

6. *Detection of NH_4 .*—In these tests the original material is examined.

Place the material in a small beaker and add a strong solution of NaOH and heat gently. Fan the fumes towards your nose to get the odor of NH_3 , which is characteristic.

Minute amounts of ammonia may be detected in water by the Nessler's Reagent. An alkaline solution of mercuric potassium iodide added to water containing "traces" of NH_4^+ produces a yellow coloration. In moderate amounts of NH_4^+ a reddish brown precipitate is obtained of $\text{NH}_2\text{I}\cdot\text{H}_2\text{O}$.

7. Obtain an unknown solution of the group and make tests for magnesium, sodium and potassium. See Table V.

§ 31

TABLE V

ANALYSIS OF THE SOLUBLE BASIC GROUP

Preparation of Solution

Divide the filtrate from the ammonium-carbonate group into two portions: *A*, one-third, and *B*, two-thirds. Test portion *A* for magnesium, and meantime evaporate portion *B* to small bulk over a flame and finally to dryness on a sand bath, and proceed as indicated in *B*, below. (If NH_4 is present heat to expel ammonium salts.)

Removal of the Alkaline Earth Metals

A. Before proceeding to the test for magnesium, traces of the previous group must be removed from the solution. In order to detect the presence of these add a few drops of the solution to about 2–5 cc. of a strong solution of $(\text{NH}_4)_2\text{SO}_4$; a slight turbidity indicates the presence of strontium or barium or both. To detect the presence of calcium add one or two cubic centimeters of the solution to an equal volume of $(\text{NH}_4)_2\text{C}_2\text{O}_4$; a slight turbidity is due to the formation of CaC_2O_4 . If the tests indicate Sr, Ba, or Ca, add to the remainder of the portion *A* the reagents effecting their precipitation, and filter.

Detection of Magnesium

Residue.—Reject. Solution contains magnesium and the alkalis. Concentrate the solution to about 5 cc. (Filter off any precipitate that may form.) To the filtrate add 1–5 cc. $(\text{NH}_4)_2\text{HPO}_4$ solution and stir with a glass rod. A white, crystalline precipitate forming slowly, crystallizing in streaks wherever the rod has touched the beaker, proves the presence of *Magnesium*. (The solution should be made alkaline with NH_4OH before the addition of $(\text{NH}_4)_2\text{HPO}_4$, if not already so.)

Confirmation of MgNH_4PO_4 .—Dissolve the precipitate in a little acetic acid. To the clear filtrate add NH_4OH to make the solution alkaline. Stir vigorously and allow to stand. MgNH_4PO_4 is again precipitated. (See optional test, following § 30.)

Separation of the Alkalies—Potassium, Sodium and Lithium

B. (a) Procedure in Presence of Magnesium and the Alkaline Earths.—To remove magnesium expel the ammonium salts by heating the residue obtained, by evaporation, to a temperature below dull redness until no more white fumes are driven off. (Hood.) Heat the sides of the dish as well as the bottom. Dissolve the residue in about 5 cc. of water and add $\text{Ba}(\text{OH})_2$, drop by drop, until no further precipitation occurs. The precipitate is $\text{Mg}(\text{OH})_2$. Filter, rejecting the residue. To the filtrate add a few drops of $(\text{NH}_4)_2\text{SO}_4$ to remove barium. When the precipitation is complete add several drops of $(\text{NH}_4)_2\text{C}_2\text{O}_4$ and filter. Reject the precipitate. (Ba, Sr, Ca.) Evaporate the solution to dryness.

(b) *Procedure after the Removal of Magnesium and the Alkaline Earths.*—Expel the ammonium salts by heating in a hood, to a temperature below dull redness until no more white fumes are driven off. (Heat sides as well as the bottom of the dish.) Add about 10 cc. of water containing a few drops of HNO_3 (1.4), warm and filter, and again evaporate the filtrate to dryness. Take up the residue with 5–10 cc. of water. Filter if not clear. Divide into two portions. I and II. (Test a portion by flame test for Na and K.)

Portion I.—Add a few drops of acetic acid if the solution is not already acid, and an equal volume of $\text{Na}_2\text{Co}(\text{NO}_2)_6$. Allow to stand 10 to 20 minutes if a precipitate does not form readily. A yellow precipitate is $\text{K}_2\text{NaCo}(\text{NO}_2)_6 + \text{aq.}$, best seen on filter paper upon removal of the reagent by washing. Filter and wash residue with water, a few drops at a time.

Potassium may also be detected by precipitation as K_2PtCl_6 , but this procedure is no longer commonly used owing to the high cost of platinum.

Confirm.—Dissolve residue in a little hot HCl (1.12). Evaporate to a few drops and test the concentrated solution in the flame, cutting out the yellow rays by blue glass of sufficient density. A violet red color indicates potassium.

Portion II.—If the solution reacts acid, make neutral by the addition of a drop or so of KOH . Evaporate to about 1 cc., cool, and add 1 to 2 cc. $\text{K}_2\text{H}_2\text{Sb}_2\text{O}_7$; pour into a test tube and allow to stand for some time (at least half an hour or longer). A white crystalline precipitate is $\text{Na}_2\text{H}_2\text{Sb}_2\text{O}_7$.

Confirm.—Decant off the solution. Wash the precipitate by adding small amounts of water at a time. Test the residue in the flame, upon the addition of a drop or so of HCl to bring it into solution. A brilliant yellow flame proves the presence of *Sodium*. Examine the flame by means of the spectroscope to detect the presence of *Lithium*.

Examine by spectroscope. A flame violet-red giving a red and a blue line proves *Potassium*.

Ammonium.—Test original substance or solution by warming with a little NaOH . Odor of ammonia.*

Moist red litmus paper is colored blue by NH_3 . In warming the paper the NH_3 is volatilized and the red color restored. (Distinction from the other alkalis.)

Optional Method for Potassium and Sodium.—Add about 5 cc. HClO_4 to ignited residue containing K and Na. Evaporate to dense fumes. Cool and add 20 cc. of 95 per cent $\text{C}_2\text{H}_5\text{OH}$. Stir, filter through dry filter and wash with 95 per cent $\text{C}_2\text{H}_5\text{OH}$.

Residue = KClO_4 .

Confirm.—Dissolve with 10 cc. hot water, poured repeatedly through filter. Cool and add $\text{Na}_2\text{Co}(\text{NO}_2)_6$ reagent = yellow ppt. $\text{K}_2\text{NaCo}(\text{NO}_2)_6$. M a k e flame test = violet color.

Solution.— NaClO_4 . Pour alcoholic solution into flask and saturate with dry HCl gas = NaCl ppt. Filter and wash with 95 per cent $\text{C}_2\text{H}_5\text{OH}$ (alcoholic filtrate is explosive if heated. Reject.)

Confirm.—Dissolve by pouring repeatedly through filter, 10–15 cc. water. Evaporate to dryness. Take up with 1 cc. of water and test as in Portion II, above.

* Be watchful of spurting during the heating with NaOH . Test odor by fanning the fumes towards your nose.

CHART V
SOLUBLE GROUP, MAGNESIUM AND THE ALKALIES

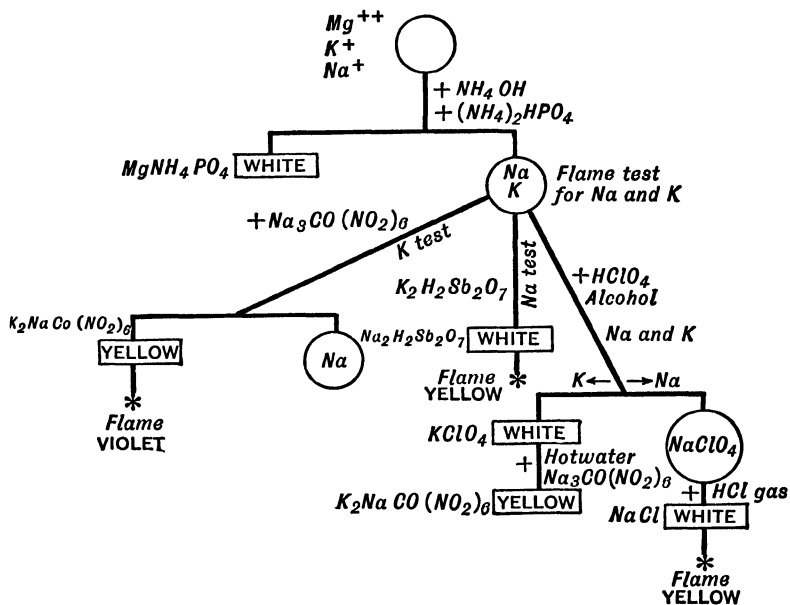

SUMMARY AND CHEMICAL PRINCIPLES OF THE SOLUBLE GROUP

§ 32. Direct tests may be made for members of this group in presence of one another so that it is not necessary to effect a complete separation as in case of previous groups. Since Na_2HPO_4 precipitates the alkaline earth metals the removal of these is necessary for a reliable test for magnesium, since the carbonates of Ba, Ca and Sr are slightly soluble and small amounts pass into the filtrate containing the soluble group. This removal is accomplished on one-third portion of the solution by adding $(\text{NH}_4)_2\text{C}_2\text{O}_4$ and $(\text{NH}_4)_2\text{SO}_4$, boiling and filtering off the precipitated alkaline earths. The concentrated filtrate is tested for magnesium. The remaining two-thirds of the original solution is evaporated to dryness and heated to expel the accumulated ammonium salts, which interfere in the detection of potassium on account of the similarity of ammonium compounds that would form with reagents used. These salts are volatilized at a temperature where practically no loss by volatilization of the alkalis occurs. Tests for sodium and potassium are made in separate portions.

Ammonia is looked for in the original sample for the obvious reason that reagents containing this compound are used in the course of analysis.

1. Test for Magnesium.—Since the phosphates of the alkaline earths are all insoluble in alkaline solutions, calcium, barium, and strontium must be removed completely from the solution before making the test for magnesium. See also the organic reagent test for magnesium.

Sodium and Potassium

Evaporation.—Ammonium salts must be expelled, since they may be mistaken for potassium. The residue is not heated to redness, as the alkali chlorides will volatilize when highly heated.

Precipitation.—The residue obtained upon the expulsion of the ammonium salts may be tested directly by flame and spectroscopic tests by dissolving it in a few drops of HCl . The difficulty

lies principally in the detection of potassium in the presence of sodium. A blue glass of sufficient density to cut out the yellow rays of sodium should be used. Again the fact that sodium is always present in the reagents and in the air makes the direct flame test unsatisfactory, as a yellow color will always be obtained with the residue, hence the advisability of using the precipitation test, since these traces will not respond to this test. For satisfactory results great care must be used.

2. Test for Potassium.—The solution must not be alkaline when the reagent is added, since $\text{Co}(\text{OH})_3$ would precipitate as soon as $\text{Na}_3\text{Co}(\text{NO}_2)_6$ is added to alkaline solutions, hence the addition of acetic acid.

3. Test for Sodium is made from neutral solutions, as $\text{Na}_2\text{H}_2\text{Sb}_2\text{O}_7$ dissolves in acids. The salt is a heavy crystalline precipitate, which may require some time for complete precipitation. The precipitate due to the presence of lithium is similar to that of sodium. The flame and spectroscopic tests serve as a ready method of distinction, since lithium gives a carmine-red flame, and has in its spectrum a red and a feeble orange line. A fleeting yellow color should not be taken as evidence of the presence of sodium.

Test for Ammonia is made with the original solution or solid, since during the process of analysis this substance has been added as a reagent in both the Ammonium-Sulfide and Ammonium-Carbonate Groups. It is not necessary to dissolve the sample, as the test may be made of the solid substance.

See methods on page 98.

Reagents.—*Sodium Cobaltinitrite.*—Dissolve 100 grams of NaNO_2 in 200 cc. of water, add 60 cc. acetic acid (30 per cent) and 10 grams of $\text{Co}(\text{NO})_2 \cdot 6\text{H}_2\text{O}$. Allow to stand for two or three days; filter and dilute to 400 cc.

Dipotassium Dihydrogen Pyroantimonate.—Dissolve 3 grams of the best commercial salt, $\text{K}_2\text{H}_2\text{Sb}_2\text{O}_7$, in 100 cc. of boiling water and boil the solution for about a minute, cool quickly and add 3 cc. KOH (10 per cent) and filter.

§ 33

CLASSROOM REVIEW OF THE SOLUBLE BASIC GROUP

1. Why does NaOH cause precipitation of $\text{Mg}(\text{OH})_2$, while NH_4OH gives only a partial precipitation, and no precipitation in presence of NH_4Cl . (Solubility product, common ion effect.)
2. Why is the yellow coloration of the flame not a conclusive test for sodium in the material examined.
3. How would the equilibrium of the reaction $\text{Mg}(\text{OH})_2, \text{solid} = \text{Mg}(\text{OH})_2, \text{solution} = \text{Mg} + 2\text{OH}^-$ be effected by the addition of ammonium salt?
4. Why is it necessary to test for ammonium radical in the original solution?
5. What precautions are observed in testing for magnesium?
6. Why is it necessary to remove ammonium salts before testing for potassium?
7. What metals have been examined by means of the spectroscope?
8. What metals have been discovered by means of the spectroscope?
9. NH_4Cl prevents the precipitation of $\text{Mg}(\text{OH})_2$ by NH_4OH , would NaCl prevent the precipitation of $\text{Mg}(\text{OH})_2$ by NaOH ?
10. Why is the reaction between HClO_4 and $\text{C}_2\text{H}_5\text{OH}$ explosive?
11. Distinguish between decomposition and dissociation, using the compounds NH_4Cl and NH_4NO_3 as examples.
12. Give the colors of the flames produced by heating chlorides of the following in the flame: sodium, potassium, calcium, barium and strontium.
13. Give the formula of the precipitate of sodium formed in its detection.
14. Give one formula of potassium that is formed in its detection.
15. Give the formula of magnesium that is formed when a soluble phosphate reacts with magnesium in presence of an excess of ammonia in solution.
16. Complete the following equations, balancing the same:
 - (a) $\text{MgCl}_2 + 2\text{NH}_4\text{OH} = \text{Mg}(\text{OH})_2$
 - (b) $\text{MgCl}_2 + (\text{NH}_4)_2\text{CO}_3 = \text{MgCO}_3$
 - (c) $\text{Mg}(\text{OH})_2 + \text{NH}_4\text{Cl} + \text{NH}_3 = \text{Mg}(\text{NH}_2)_2\text{Cl}_2 \text{ (sol)}$
 - (d) $\text{MgCl}_2 + \text{Na}_2\text{HPO}_4 + \text{NH}_4\text{OH} = \text{NH}_4\text{MgPO}_4$
 - (e) $\text{MgCl}_2 + \text{Ba}(\text{OH})_2 = \text{Mg}(\text{OH})_2$
 - (f) $\text{NH}_4\text{Cl} + \text{NaOH} = \text{NH}_3$
 - (g) $\text{KCl} + \text{H}_2\text{PtCl}_6 = \text{K}_2\text{PtCl}_6$
 - (h) $\text{KCl} + \text{Na}_2\text{Co}(\text{NO}_2)_6 = \text{K}_2\text{NaCo}(\text{NO}_2)_6$
 - (i) $\text{KCl} + \text{HClO}_4 = \text{KClO}_4$
 - (j) $\text{NaCl} + \text{K}_2\text{H}_2\text{Sb}_2\text{O}_7 = \text{Na}_2\text{H}_2\text{Sb}_2\text{O}_7$
17. Why is alcohol used in the precipitation of KClO_4 by HClO_4 ?

18. Explain why NaCl precipitates when HCl is passed into a solution saturated by NaCl.

19. Why is $\text{Na}_2\text{Co}(\text{NO}_2)_6$ in solution spoken of as a complex salt?

20. What other sodium salts are possible by the action of this metal with antimonious acid?

The following Chart VI gives a brief summary of the group separations. For examination of a general unknown consult the chapter on the Systematic Analysis of Substances at the close of this text.

CHART VI

SUMMARY—ALL BASIC GROUPS

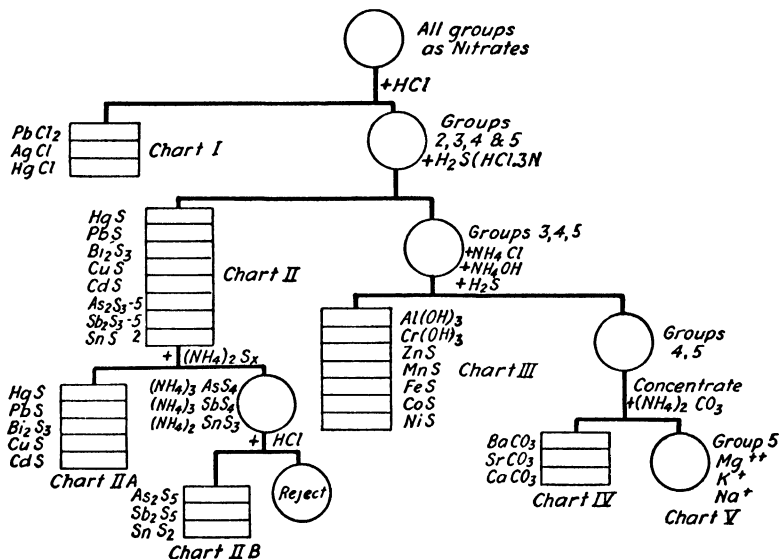

Separation of the Base Metal Groups.

SCHEME FOR SEPARATION AND IDENTIFICATION OF THE METALLIC ELEMENTS WITHOUT THE USE OF H₂S GAS

A number of investigators have suggested methods of separations of the basic elements without the use of the objectionable hydrogen sulfide gas. For our study of the subject we have chosen the general scheme recommended by C. J. Brockman,* slightly modified.

In the separation of the groups, the method adheres to the standard procedure for separation of silver, mercurous mercury and lead as chlorides. Barium, calcium and strontium (and any lead remaining from the HCl group) are precipitated as sulfates in presence of ethyl alcohol. The precipitation of water insoluble hydroxides by addition of NaOH or KOH and an oxidizing agent H₂O₂ or Na₂O₂ enables a separation of a number of elements from the amphoteric elements—aluminum, tin, antimony, zinc, arsenic and chromium. Potassium hydroxide is preferred to sodium hydroxide as the sodium salts of these elements are not as soluble as the potassium compounds. The author of this text (W. W. S.) prefers to place the water insoluble hydroxides in one group, classifying the elements precipitated as phosphates in presence of ammonium ion as a subgroup, and the elements that remain in solution from the phosphate precipitations as complex amino compounds as a subgroup, as in case of the subdivisions of the hydrogen sulfide group. Since alkalis are added in making the separations, it is necessary to test for sodium, potassium and ammonium in the original sample. The chart below shows the classification, with the reagents used and the compounds formed.

GROUPS

Alkalies	HCl Group	H ₂ SO ₄ Group	Hydroxide Group		Amphoteric Group
			A	B	
NH ₄ ⁺	AgCl	PbSO ₄	MnO(OH) ₂	Cu(OH) ₂	KAlO ₂
Na ⁺	HgCl	BaSO ₄	Fe(OH) ₃	PbO	K ₂ SnO ₃
K ⁺	PbCl ₂	CaSO ₄	Bi(OH) ₃	Cd(OH) ₂	KSbO ₃
Test for in original sample		SrSO ₄	Mg(OH) ₂	Co(OH) ₂	K ₂ ZnO ₂
				Ni(CO) ₂	K ₂ AsO ₄
					K ₂ CrO ₄

This group separation entails new schemes for the separation of the individual members from one another and may necessitate slight changes in final identification. With the knowledge attained in the study of the elements in the previous portion of this text, the chemical reactions shown in the charts that follow, will be of interest, and offer an instructive study.

The alkalies are detected in the original material. The ammonium radical by treating a portion of the material with NaOH solution and testing the evolved gas (NH₃) with moist litmus paper, which turns blue, or a strip of filter paper moistened with mercurous nitrate, which turn black in presence of NH₃. Sodium is detected by the flame test in a chloride solution, sodium coloring the flame yellow. Potassium is tested for also by the flame test, viewed through a cobalt glass to absorb the yellow color of sodium, potassium (as chloride) colors the flame violet. The color flashes out rapidly, that of sodium is more persistent.

* Qualitative Analysis, C. J. Brockman, Ginn and Co., Publishers.

CHART VII
 OUTLINE OF SEPARATIONS WITHOUT THE USE OF H₂S
 SEPARATION OF GROUPS

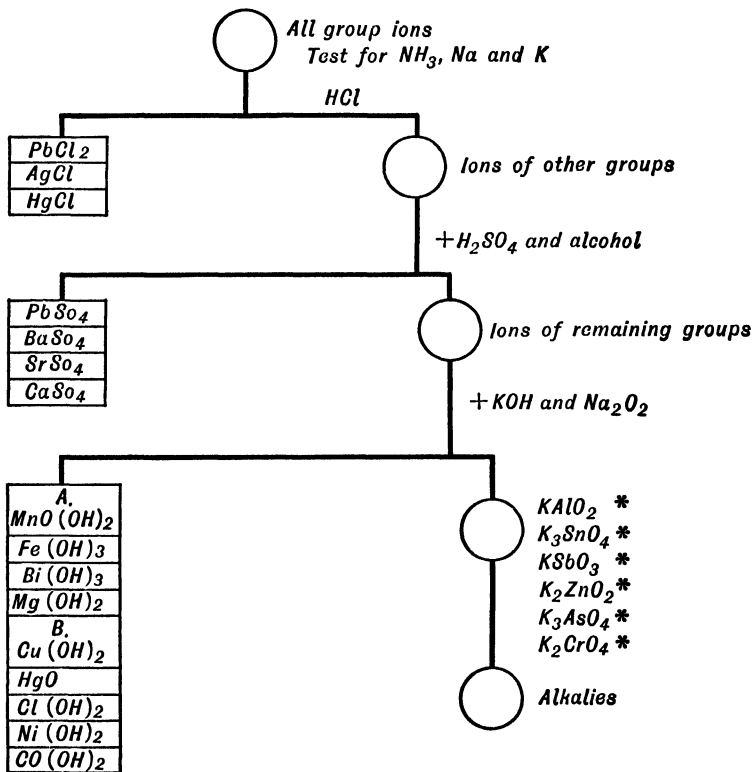

Hydrochloric Acid Group.—This group separation has been given in the beginning of this text.

* The potassium salts of these elements are generally more soluble than the sodium salts so that the use of KOH has an advantage over NaOH.

CHART VIII
INSOLUBLE SULFATE GROUP

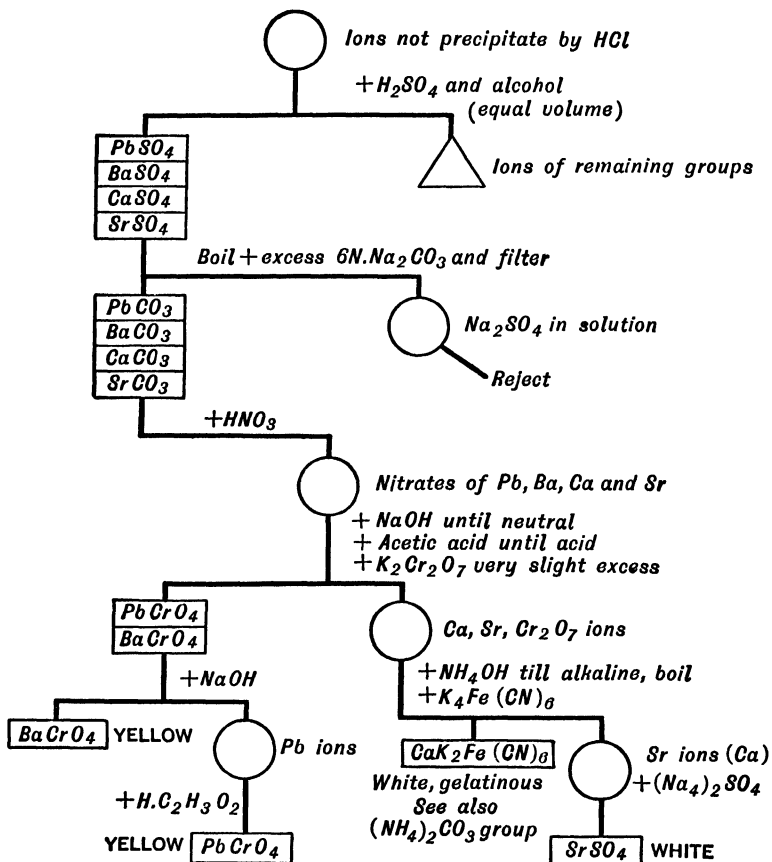

Discussion on Separations.—The sulfates of lead, barium, calcium and strontium are transported to carbonates by boiling with an excess of sodium carbonate. With the sodium sulfate solution filtered off, the carbonates can be easily decomposed and the elements converted to soluble acetates, first changing to nitrates and adding acetic acid to the neutralized solution. Lead and barium chromates are separated from calcium and strontium, due to the insolubility of BaCrO_4 and PbCrO_4 in acetic acid. Lead chromate is soluble in KOH or NaOH and may be separated from BaCrO_4 , which is insoluble. Calcium is separated from strontium by precipitation as ferrocyanide from an ammoniacal solution. Strontium ferrocyanide does not precipitate. The confirmation of the elements is according to well-known procedures that have been studied in previous tests.

CHART IXA
THE HYDROXIDE GROUP

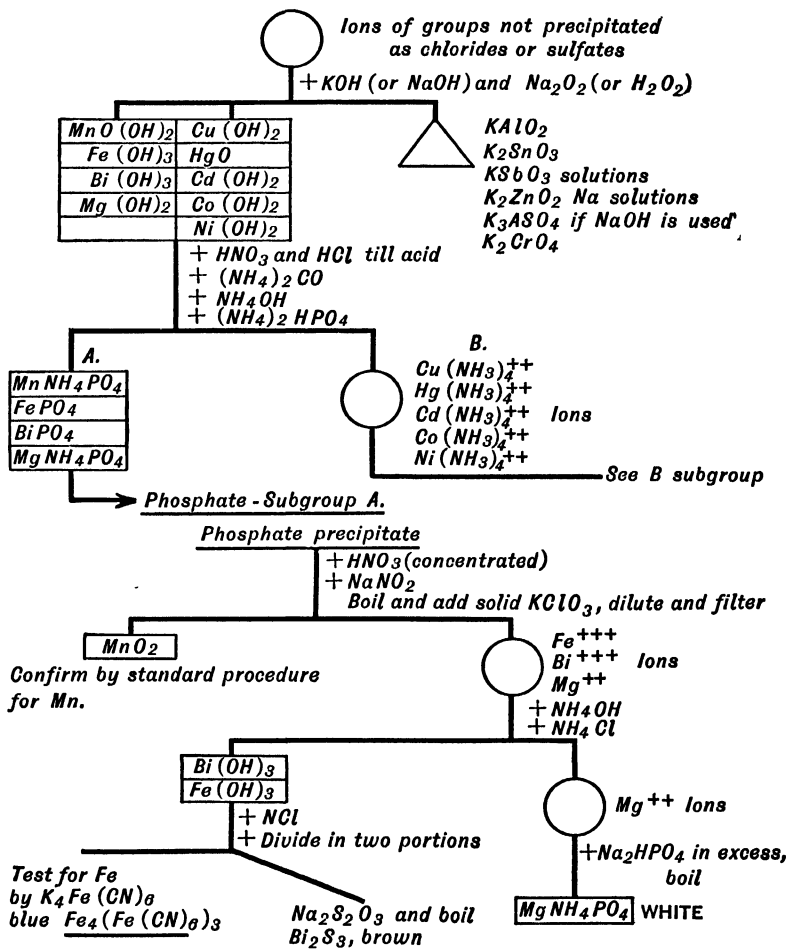

Observation.—The voluminous and difficultly filterable precipitate of hydroxides, offers some objection to the large hydroxide separation. It has been suggested to convert Cu, Hg, Cd, Co and Ni to the soluble tetramines, throwing these elements with Al, Sn, Sb, As, Zn and Cr and precipitate Mn, Fe, Bi and Mg as hydroxides with KOH. From the filtrate expel NH₃ by taking to small volume by boiling, with the removal of NH₃ the hydroxides of Cu, Hg, Cd, Co and Ni would precipitate. Suggest steps for this method. Division B would now be a distinct group.

CHART IXB
SUBGROUP B

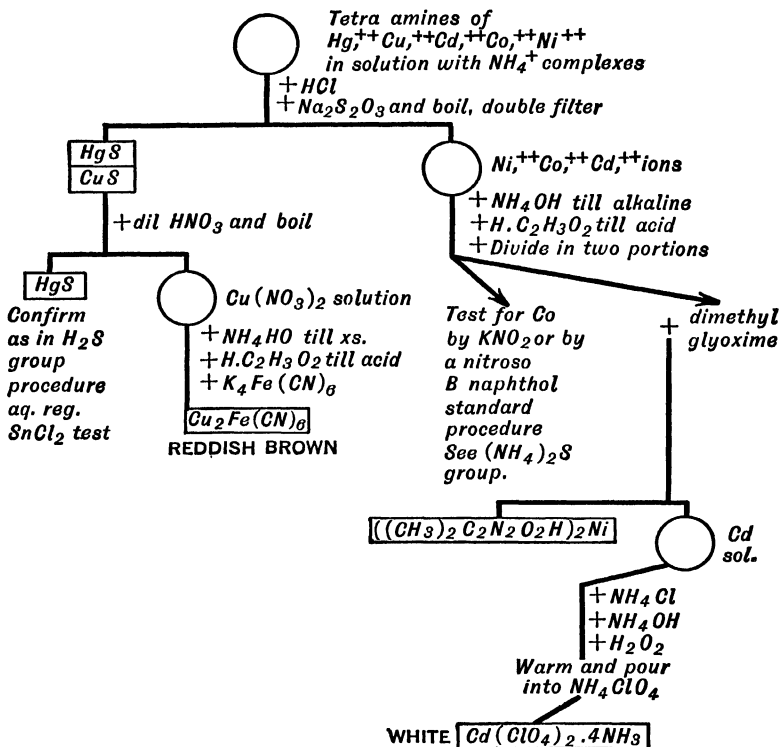

Discussion on Separation and Identification.—The separation of (a) Al, As, Sb, Sn and Cr from (b) Mn, Fe, Bi, Mg, Cu, Hg, Cd, Co and Ni depends upon the formation of the soluble alkali salts with the amphoteric elements (a) while the hydroxides, insoluble in water, are formed with the elements (b).

The separation of the hydroxides into subgroups depends upon the formation of the soluble complex ammonium ions with Hg, Cu, Cd, Co and Ni, when an excess of ammonium hydroxide and ammonium carbonate is added to the acid solution of the dissolved hydroxides, resulting in the ions shown under subgroup B. Upon the addition of diammonium hydrogen phosphate, manganese, iron, bismuth and magnesium precipitate as phosphates while copper, mercury (ic) cadmium, cobalt and nickel remain in solution.

The phosphates of subgroup A are brought into solution with HNO_3 and addition of $NaNO_2$, if the latter is necessary, the solution is boiled and manganese precipitated as MnO_2 , according to the standard procedure, by addition of $KClO_3$. Iron and bismuth are now precipitated as hydroxides and separated from magnesium, which stays in solution in presence of NH_4Cl . Bismuth and iron, brought into solution, may be identified in presence of one another as indicated. Magnesium is precipitated as phosphate by the customary procedure.

CHART X
SOLUBLE AMPHOTERIC GROUP

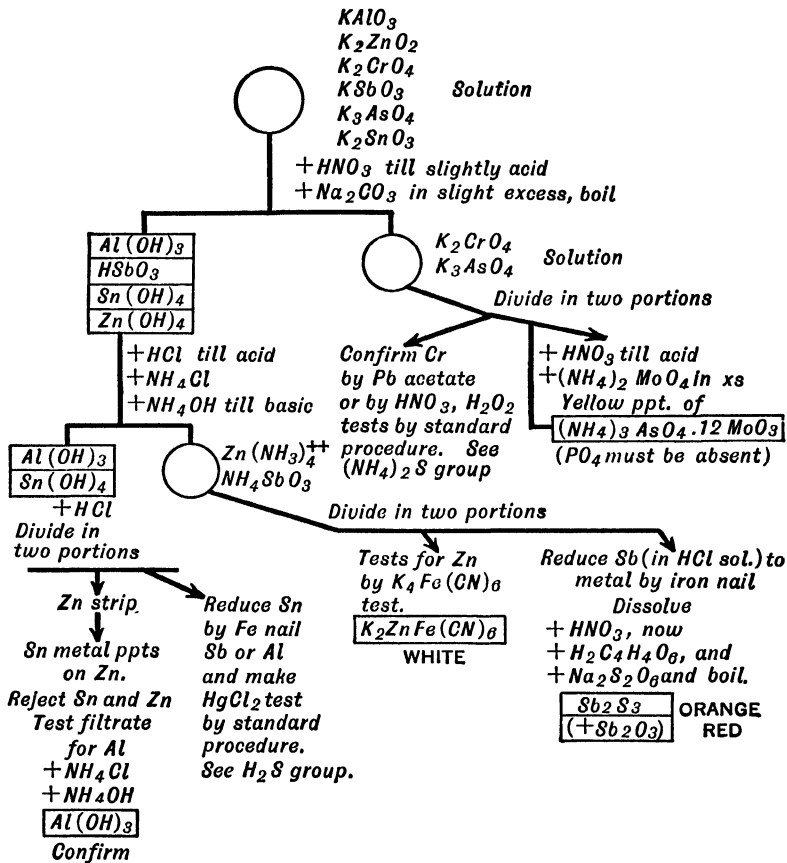

PART II

THE ACID RADICALS OR ANIONS

§ 34. Acids contain one or more H^+ cations, replaceable by metals or basic substances with formation of salts. Although no satisfactory procedure has been developed for the systematic separation of the anions as has been accomplished with the cations, advantage is taken of general groupings and special separations as well as the fact that the presence of certain cations preclude the presence of certain anions, for example: chlorine, bromine and iodine would not be found in water solutions which contained silver ions, nor would the sulfate ion occur in a solution containing barium or lead cations. The presence of an oxidizing substance would preclude the presence of a reducing substance in a solution, namely—in a permanganate solution would not be found a nitrite, a sulfite, a sulfide or other oxidizable anion. Fortunately there are present but a few of acid radicals in natural or commercial products. Water insoluble minerals are generally limited to carbonate, phosphate, silicate, sulfide, sulfate, borate, arsenite, fluoride, chloride and occasionally cyanide. In our general grouping we will consider the acids under three heads, and study these in the order named:

I. *Barium Reagent or Sulfate Group*.—Anions whose barium salts are insoluble in water—carbonate, sulfate, phosphate, chromate, fluoride, arsenate, arsenite, sulfite, borate, oxalate, tartrate, silicate, thiosulfate.

II. *Silver Reagent or Chloride Group*.—Anions whose barium salts are soluble in water, but whose silver salts are insoluble even in presence of dilute HNO_3 —chloride, bromide, iodide, sulfide, ferrocyanide, ferricyanide, cyanide, thiocyanate.

III. Soluble Acid or Nitrate Group.—Acids whose barium and silver salts are soluble in water—nitrate, nitrite, acetate, chlorate, permanganate.

As in case of the study of the metals comparative tests will be found of value, taking solutions containing known amounts of the radicals. The preliminary tests of the individuals will be followed by a study of the systematic scheme for examination of unknowns, including the preparation of the solution for analysis, in the chapter on the systematic analysis of a substance.

Test Solutions.—Although it is frequently possible to test the free acids, it is generally advisable to make the tests with the soluble sodium salts of the acids. Details for preparing the solution are given in paragraphs 38 and 43.

I. BARIUM REAGENT OR SULPHATE GROUP

PRELIMINARY INDIVIDUAL TESTS

§ 35. *Test Solutions.*—Sodium salts of the acids made according to directions in table at the close of this text.

The table gives the order in which the anions will be studied with compounds formed by the test reagents.

Acid Radical	BaCl ₂ (CaCl ₂)	Special Tests
1. Carbonate	(a) BaCO ₃	(b) CO ₂ (c) CaCO ₃
2. Sulfate	BaSO ₄	
3. Chromate	(a) BaCrO ₄	(b) PbCrO ₄ (c) Ag ₂ CrO ₄ (d) CrCl ₃
4. Phosphate	(a) BaHPO ₄ Ba ₃ (PO ₄) ₂	(b) (NH ₄) ₃ PO ₄ ·12MoO ₃ (c) Ag ₃ PO ₄
5. Fluoride	(a) BaF ₂	(b) H ₂ SiF ₆
6. Sulfite	(a) BaSO ₃	(b) SO ₂ (c) Reduction. MnO ₂
7. Borate	(a) Ba(BO ₂) ₂	(b) (C ₂ H ₅) ₃ BO ₃ (c) Turmeric test
8. Oxalate	(a) BaC ₂ O ₄ ·H ₂ O CaC ₂ O ₄ ·H ₂ O	
9. Tartrate	(a) BaC ₄ H ₄ O ₆ ·H ₂ O	(b) Charring with gas.
10. Silicate	(a) BaSiO ₃	(b) HF (c) Water bead test.
11. Thiosulfate	(a) BaS ₂ O ₃	(b) Acid test (c) Iodine test.

Tests are made with 2-5 cc. portions of the test solutions as is indicated.

1. Carbonate, CO₃⁻

(a) *Barium Chloride Test.*—To 2 cc. of the carbonate test solution in a test tube add BaCl₂ solution in dilute HCl (1 : 1). Write reactions between Na₂CO₃ and BaCl₂, BaCO₃ and HCl.

(b) *Acid Action on a Carbonate.*—Place a little of Na₂CO₃ powder in a test tube and add a little water followed by dilute HCl (1 : 1). What occurs?

(c) *Lime Water Test.*—Pass CO₂, generated as stated in (b), into lime water (see Fig. 6). The white precipitate is CaCO₃. Write reactions.

Bicarbonate.—Magnesium sulfate causes no precipitation with a bicarbonate, a white precipitate is obtained with a carbonate. Mercuric chloride produces no precipitate with bicarbonate, the normal carbonate reacts to form the reddish basic oxide of mercury. Sodium or potassium bicarbonates are neutral to phenolphthalein indicator, carbonates of sodium and potassium are alkaline to this indicator. (Red color obtained.)

2. Sulfate, SO_4^{2-}

(a) *Barium Chloride Test*.—To 2 cc. of Na_2SO_4 solution in a test tube add about 5 cc. of water and then a little BaCl_2 solution. The precipitate is BaSO_4 . Test the solubility of BaSO_4 in a little dilute HCl .

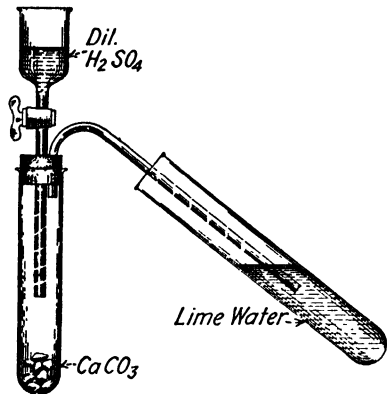

FIG. 6.—Test for CO_2 .

of K_2CrO_4 add a little AgNO_3 reagent. Does the yellow Ag_2CrO_4 dissolve in dilute HNO_3 ?

(d) *Reducing Agents*.—To an acid solution of K_2CrO_4 add a little alcohol and boil. The yellow color changes to green.



4. Phosphate, PO_4^{3-}

(a) *Barium Chloride Test*.—To 2 cc. of $\text{NaNH}_4\text{HPO}_4$ (or other soluble phosphate) add BaCl_2 solution. Does the precipitate dissolve in dilute HCl ? Is it reprecipitated upon adding NH_4OH in excess?

(b) *Ammonium Molybdate Test*.—To about 5 cc. of water add 5–6 drops of $\text{NaNH}_4\text{HPO}_4$ test solution. Acidify with a few drops of dilute HNO_3 (1 : 1); add 10 cc. of $(\text{NH}_4)_2\text{MoO}_4$ reagent. Place the test tube for a few minutes in warm (not hot) water. A yellow precipitate will form having the composition $(\text{NH}_4)_3\text{PO}_4 \cdot 12\text{MoO}_3$. Test its solubility in NH_4OH .

(c) *Silver Nitrate Test*.—Dilute 2 cc. of phosphate test solution with an equal volume of water and add a few drops of AgNO_3 . Is the yellow Ag_3PO_4 soluble in HNO_3 (1 : 1)?

5. Fluoride

(a) *Barium Chloride Test*.—To a small amount of sodium or potassium

3. Chromate, CrO_4^{2-}

(a) *Barium Chloride Test*.—To 2 cc. of K_2CrO_4 test solution add a little BaCl_2 . The yellowish precipitate is BaCrO_4 . Test its solubility in dilute HCl (1 : 1). Write reactions.

(b) *Lead Acetate Test*.—To 2 cc. of K_2CrO_4 solution add a little lead acetate reagent. The yellow precipitate is PbCrO_4 . Test its solubility in dilute acetic acid. Does it dissolve in dilute HCl ?

(c) *Silver Nitrate Test*.—To 2 cc.

fluoride solution in a test tube add a few cubic centimeters of BaCl_2 reagent. The precipitate is BaF_2 . Test its solubility in dilute HCl . Write reactions.

(b) *Calcium Chloride Test*.—Try action of CaCl_2 solution on NaF solution. Test solubility of CaF_2 in HCl . Write reactions.

(c) *Etching Test*.—(Hood)—In a small Erlenmeyer flask place a little of the solid fluoride, pour in sufficient strong H_2SO_4 to cover sample. Now place over the mouth of the flask a small watch glass with a drop of water suspended from its curved surface (see Fig. 7). Heat the flask gently. An etch is obtained on the spot to which the drop of water clings.

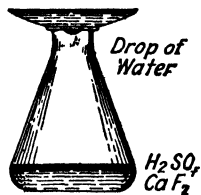

FIG. 7.—Test for Fluoride.

6. Sulfite, SO_3^-

(a) *Barium Chloride Test*.—To a little sulfite test solution add BaCl_2 reagent. Test the solubility of the BaSO_3 in dilute HCl .

(b) *Acid Test*.—To a little Na_2SO_3 solid, in a test tube, add a little water and then a few cubic centimeters dilute HCl . Note the odor of the evolved SO_2 , by cautiously fanning the fumes towards you. Do not smell the fumes directly without dilution with air.

Note.— SO_2 is a strong reducing agent. Pour a few drops of solution (b) into 1 cc. of a KMnO_4 test solution and note the fading of the color.

7. Borate, BO_3^-

(a) *Barium Chloride Test*.—To 2 cc. of borax test solution add a little BaCl_2 reagent. Test the solubility of the $\text{Ba}(\text{BO}_2)_2$ in dilute HCl .

(b) *Alcohol Flame Test*.—Place a little powdered borax in a small evaporating dish and moisten with strong H_2SO_4 and add about 5 cc. of ethyl alcohol. Mix warm and set fire to the alcohol vapors. A greenish colored flame will be obtained due to volatile ethyl borate, $(\text{C}_2\text{H}_5)_3\text{BO}_3$.

(c) *Tumeric Paper Test*.—Dip a piece of tumeric paper into a solution of borax acidified with HCl . Dry on a watch glass over a beaker of boiling water. Note the brownish red to pink color produced. Add a drop of dilute NaOH solution and observe greenish brown to black color produced.

8. Oxalate, C_2O_4^-

Calcium Chloride Test.—This test is the reciprocal of the test for calcium, with which we have become familiar in the study of the alkaline earth metals. Add to 5 cc. of $(\text{NH}_4)_2\text{C}_2\text{O}_4$ solution 2–3 cc. of CaCl_2 solution. Test the solubility of $\text{CaC}_2\text{O}_4 \cdot \text{H}_2\text{O}$ in HCl . Review the chapter on alkaline earth group.

9. Tartrate, $C_4H_4O_6^-$

Sulfuric Acid Test.—To a few crystals of tartaric acid in a test tube add a little concentrated H_2SO_4 and warm gently. Note the charring that takes place and the odor of the evolved gas.

Tartrates prevent precipitation of iron hydroxide as do many of the organic acids. These are destroyed before undertaking the examination of the ammonium-sulfide group.

10. Silicate, SiO_2^-

(a) Barium chloride precipitates white $BaSiO_3$, soluble in acids. Prove this.

(b) *Hydrofluoric acid* added to the dry solid suspended in concentrated sulfuric acid and the mixture warmed causes gas bubbles of SiF_4 to evolve.

(c) *Water bead test.*—A platinum wire with a loop, containing a drop of water is held in the gas evolved from test *b*. In presence of SiO_2 or silicate the drop becomes turbid.

11. Thiosulfate, $S_2O_3^-$

(a) *Barium chloride* in concentrated solutions of sodium thiosulfate precipitates white BaS_2O_3 . Does the precipitate dissolve on heating the solution?

(b) Dilute sulfuric or hydrochloric acid decomposes thiosulfates with the liberation of SO_2 gas and free sulfur. Note the odor of the evolved gas.

(c) An iodine solution is bleached by when a sufficient quantity of thiosulfate is added, the tetrathionate and iodide (colorless) being formed.

§ 36

II. SILVER REAGENT OR CHLORIDE GROUP

PRELIMINARY INDIVIDUAL TESTS

The following table is a summary of the tests of this group.

Acid Radical	AgNO ₃	Special Tests
1. Chloride	(a) AgCl	(b) Ag(NH ₃) ₂ Cl
2. Bromide	(a) AgBr	(b) Br.CCl ₄
3. Iodide	(a) AgI	(b) I.CCl ₄
4. Sulfide	Ag ₂ S	
5. Ferrocyanide	(a) Ag ₄ Fe(CN) ₆ .H ₂ O	(b) Fe ₄ (Fe(CN) ₆) ₃ Prussian blue
6. Ferricyanide	(a) Ag ₃ Fe(CN) ₆	(b) (c) Fe ₃ (Fe(CN) ₆) ₂ Turnbull's blue.
7. Thiocyanate	(a) AgSCN	(b) Fe(CNS) ₃
8. Cyanide	(a) AgCN	(b) Ag(CN) ₂ K (b) CuS test.

Note.—Nitrite may be included in this group owing to the slight solubility of silver nitrite. We will consider this in the soluble group.

1. Chloride, Cl⁻

Silver Nitrate Test.—To 2 cc. of sodium chloride test solution diluted to about 5 cc. add a few drops of AgNO₃ reagent. The white precipitate AgCl is soluble in NH₄OH but not in dilute HNO₃. Review the first metal group.

2. Bromide, Br⁻

(a) *Silver Nitrate Test.*—To 2 cc. of KBr test solution add a few drops of AgNO₃ reagent. Observe the color of the precipitate as compared to AgCl. Test the solubility of the precipitate in dilute HNO₃ and in NH₄OH.

(b) *Chlorine Oxidation Test.*—To 2 cc. of KBr solution add 5 cc. of water and a few drops of Cl water. Note the change of color in the solution. Now add about 2 cc. of CCl₄ and shake. On standing, the CCl₄ will separate out as a reddish colored solution.

(c) *Permanganate Oxidation Test.*—Place 1 cc. of KBr with about 5 cc.

of water in a test tube and add drop by drop a solution of KMnO_4 until the purple color remains. Now add 2 cc. of CCl_4 solution, shake, settle and note that the CCl_4 layer is colored by the free Br.

3. Iodide, I^-

(a) *Silver Nitrate Test.*—Add a little AgNO_3 solution to 2 cc. of KI test solution. Note the color of the AgI precipitate and compare with AgCl . Test the solubility of AgI in dilute HNO_3 and in NH_4OH .

(b) *Chromate Oxidation Test.*—To 2 cc. of KI solution add dilute HNO_3 until the solution is acid (litmus test) and then add a little $\text{K}_2\text{Cr}_2\text{O}_7$ reagent drop by drop. Observe the change of color. Now add about 2 cc. of CCl_4 , shake and settle. Compare color with that of test (c) under 2. Repeat with chlorine water $2\text{I}^\circ + \text{Cl}_2^\circ = \text{I}_2^\circ + 2\text{Cl}^-$.

Note.—With liberation of I from KI reduction of $\text{K}_2\text{Cr}_2\text{O}_7$ takes place, yellow of the chromate changing to green, $\text{Cr}(\text{NO}_3)_3$.

(c) *Ferric Nitrate Test.*—Repeat test as in (b) using $\text{Fe}(\text{NO}_3)_3$ in place of $\text{K}_2\text{Cr}_2\text{O}_7$. Observe results and compare with those of (b).

4. Sulfide, S^{2-}

(a) *Silver Nitrate Test.*—To 1 cc. of sodium sulfide test solution add a few drops of AgNO_3 solution. The dark colored precipitate is Ag_2S .

(b) *Action of an Acid.*—To a little solid sulfide in a test tube add a little dilute HCl. Note the odor of the gas H_2S (highly dilute with air, do not smell directly). Hold a strip of paper moistened with lead acetate solution over the test tube. Review the H_2S test for lead. Write reactions.

5. Ferrocyanide, $\text{Fe}(\text{CN})_6^{4-}$

(a) *Silver Nitrate Test.*—To 2 cc. of $\text{K}_4\text{Fe}(\text{CN})_6$ solution diluted to 10 cc. with water, add a little AgNO_3 reagent. The yellowish white precipitate is $\text{Ag}_4\text{Fe}(\text{CN})_6$. Test its solubility in dilute HNO_3 .

(b) *Ferric Salt Test.*—To a dilute solution of $\text{K}_4\text{Fe}(\text{CN})_6$, add 2-3 drops of FeCl_3 . A blue colored precipitate is obtained or blue or greenish blue if the ion concentration is low. Look up the test for iron under metals.

6. Ferricyanide, $\text{Fe}(\text{CN})_6^{3-}$

(a) *Silver Nitrate Test.*—To a dilute solution of $\text{K}_3\text{Fe}(\text{CN})_6$, add a little AgNO_3 solution. The orange colored precipitate is $\text{Ag}_3\text{Fe}(\text{CN})_6$.

(b) *Ferric Salt Test.*—Observe that FeCl_3 added to $\text{K}_3\text{Fe}(\text{CN})_6$ produces no precipitate. Compare with 5 (b) above.

(c) *Ferrous Salt Test.*—To 2 cc. of $\text{K}_3\text{Fe}(\text{CN})_6$ test solution diluted to 10

cc. add 2-3 drops of FeSO_4 solution. The blue colored compound was met with in the chapter on the ammonium-sulfide group. Review this.

7. Thiocyanate, SCN^-

(a) *Silver Nitrate Test.*—To 2 cc. of KSCN or NH_4SCN solution add a few drops of AgNO_3 reagent. The white precipitate is AgSCN . Test its solubility in NH_4OH . Compare with AgCl . See distinctive test under (b) below.

(b) *Ferric Chloride Test.*—To a little KSCN solution acidified with HCl add a few drops of FeCl_3 . The blood red color is due to $\text{Fe}(\text{SCN})_3$. The color is destroyed by a solution of HgCl_2 or Rochelle salts.

8. Cyanide, CN^- (POISON)

(a) *Silver Nitrate Test.*—To a little KCN solution add an excess of AgNO_3 reagent. The white precipitate obtained is AgCN . Test the solubility of the AgCN in NH_4OH . The precipitate dissolves in an excess of KCN . Try this on a fresh sample.

Note.— AgCN is insoluble in dilute HNO_3 . Use great care in handling a cyanide. Never acidify a cyanide solution without proper ventilation of a hood; HCN produced is a deadly poison.

(b) *Copper Sulfide Test.*—We have learned that the precipitation of CuS can be prevented by adding KCN in sufficient quantity to the solution. The copper sulfate solution is treated with an excess of NH_4OH and CuS precipitated. (Use very dilute solution.) The cyanide solution will dissolve the CuS . It is advisable to have a second tube with suspended CuS as a control. (See details of procedure by Barneby, J. A. C. S., 1992.)

For further tests of a cyanide consult a larger work on qualitative analysis. It is not advisable to handle this poison in beginning classes unless there is ample provision for conducting the work in hoods.

§ 37

III. SOLUBLE ACIDS OR NITRATE GROUP

PRELIMINARY INDIVIDUAL TESTS

The following table gives the order of the tests.

Acid Radical	Special Tests
1. Nitrate	(a) $\text{Fe}(\text{SO}_4)_2 \cdot \text{NO}$ (b) Diphenylamine test
2. Nitrite	(a) HSCN $\text{Fe}(\text{SCN})_3$ (b) I liberated.
3. Acetate	(a) $\text{C}_2\text{H}_5 \cdot \text{C}_2\text{H}_3\text{O}_2$ (b) $\text{HC}_2\text{H}_3\text{O}_2$
4. Chlorate	(a) ClO_2 (b) ClO_2 and Cl_2
5. Permanganate	KMnO_4 MnO_2 MnCl_2

1. Nitrate, NO_3^-

(a) *Ferrous Sulfate Test.*—Pour 1 cc. of NaNO_3 solution in a test tube and add about 5 cc. of strong H_2SO_4 . Hold the test tube in a slanting position and carefully pour down the lower side 3–5 cc. of a saturated solution of FeSO_4 , flowing over the H_2SO_4 but without mixing with the acid. Tap the tube gently and note the brown ring that forms at the junction of the acid and FeSO_4 .

(b) *Diphenylamine Test.*—To 2 cc. of the solution containing the nitrate, placed on a watch glass, add 5 cc. of the reagent made by dissolving 5 mg. of diphenylamine $(\text{C}_6\text{H}_5)_2\text{NH}$, in 100 cc. of strong H_2SO_4 . Warm gently. A blue color develops in presence of nitrates. Cl^5 Br^5 I^5 Mn^7 Cr^6 Fe^3 interfere.

2. Nitrite, NO_2^-

(a) *Thiourea Test.*—To 1 cc. of the nitrite solution add carefully 1 cc. of acetic acid, then 1 cc. of a 10 per cent solution of thiourea, CSN_2H_4 , and allow to stand five minutes or so. Bubbles forming indicate a nitrite. Now add 1 cc.

HCl and 1 cc. of $\text{Fe}(\text{NO}_3)_3$ solution. A red color is produced if a nitrite is present. No color by a nitrate.

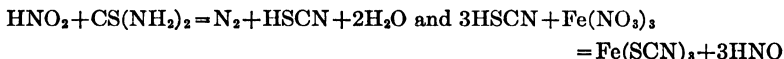

(b) *Starch Iodide Test.*—Acidify a solution of KI and starch with dilute HCl in a test tube and add a few drops of the solution containing a nitrite (solution should be acid), a blue color results in presence of the nitrite. CS_2 shaken with this solution will take up the iodine and will be colored violet.

3. Acetate, $\text{C}_2\text{H}_3\text{O}_2^-$

(a) *Alcohol Test.*—To 1 cc. of $\text{NaC}_2\text{H}_3\text{O}_2$ solution in a test tube add 2–3 cc. of $\text{C}_2\text{H}_5\text{OH}$ and 5 cc. of strong H_2SO_4 . Warm gently and note the odor of ethyl acetate, $\text{C}_2\text{H}_5\text{C}_2\text{H}_3\text{O}_2$.

(b) *Sulfuric Acid Test.*—Place a little of the solid acetate in a test tube, and a little strong H_2SO_4 and heat. The odor of acetic acid will be evident.

4. Chlorate, ClO_3^-

(a) *Sulfuric Acid Test.*—Place a little strong H_2SO_4 in a test tube, add a crystal of KClO_3 and warm. A greenish yellow gas is evolved. Heating decomposes this with a slight explosion. (Caution.)

(b) Repeat the above test with HCl. ClO_2 and Cl are evolved.

5. Permanganate, MnO_4^-

A permanganate colors a solution a violet red. The color is destroyed by adding a reducing agent such as H_2S , FeSO_4 , SO_2 , $\text{H}_2\text{C}_2\text{O}_4$, etc., to an acidified (H_2SO_4) permanganate solution.

SEPARATIONS

TABLE VI

PREPARATION OF THE SOLUTION FOR ACID ANALYSIS

Since the preparation of this solution depends largely upon the basic constituents present, this portion of the analytical work is taken up after the completion of the analysis of the cations. The chemist is now in a position to intelligently prepare the solution and to interpret reactions that will follow in the acid tests.

A. Substances Soluble in Water or Dilute Acids. Heavy Metals Absent.—(Cu, Hg, Bi, Cu, Cd, Sb, As, Sn, Fe, Al, Cr, Zn, Mn, Co, Ni, etc., sp. gr. above 5). Dissolve in water or dilute acid and use directly for acid analysis.

B. Substance Soluble in Water. Heavy Metals Present.—Add to the solution containing the substance 10–15 cc. of a saturated solution of Na_2CO_3 and boil for 15–20 minutes, replacing water if necessary. Add about 10 cc. of water, and filter.

Precipitate the heavy metals as carbonates. Reject.	Filtrate. —Filtrate containing the acids as ionized sodium salts. Neutralize with acetic acid and use for acid analysis.
--	---

Note.—If arsenic or antimony is present among the heavy metals, acidify the filtrate of the insoluble carbonates with acetic acid and pass in H_2S as long as precipitation takes place.

Precipitate. —Sulfides of As and Sb.	Filtrate. —Expel the H_2S by boiling and use for the acid analysis.
---	--

C. Substances Insoluble in Water.—Boil a gram of the substance with 15 cc. of a saturated solution of Na_2CO_3 . (Add to the substance 3–4 times its bulk of the soda and a little water sufficient to dissolve the Na_2CO_3 .) Boil 10 minutes and filter; wash with small quantities of water.

Residue. —Carbonates of the heavy metals. (Fusion with Na_2CO_3 may be necessary in some cases.)	Filtrate. —Sodium salts of the acids. Acidify with acetic acid. (Excess of carbonate is destroyed.) Now add NH_4OH in slight excess, and boil until excess is expelled. Use this solution for acid analysis.
---	---

Notes.—If only heavy metals are present, which can be precipitated by H_2S , they may be removed by suspending the solid in water, and passing in H_2S for about 20 minutes. Filter and boil the filtrate to expel H_2S , and use for analysis.

If the solution is colored by a permanganate, it can be decolorized by boiling with a few crystals of oxalic acid; filter if necessary.

Acids used to bring the substances into solution and volatile acids should be tested for in the original substance.

TABLE VII

§ 39

PRELIMINARY TESTS FOR GROUPS

Barium Chloride Group

Make a portion of the neutral solution just acid with a few drops of HCl. A cloudiness may be due to thiosulfates or sulfides and an oxidizing agent. Boil the solution and filter. Add BaCl₂ and again filter.

<p>Precipitate.— White, BaSO₄, BaSiF₆. Con- firm.</p>	<p>Filtrate.—Add CaCl₂ and NaC₂H₃O₂. Filter.</p>	
	<p>Precipitate.—White, CaC₂O₄, CaSiO₃. Yellow, CaCrO₄. Add water and boil.</p>	<p>Filtrate.—Make just alkali- line with Ba(OH)₂ solution.</p>
	<p>Precipitate.— CaSiO₃. In- soluble.</p>	<p>Solution.— Y e l l o w , CaCrO₄.</p>
	<p>Precipitate.—White indi- cates any of the following: As³⁺, PO₄, BO₃, C₄H₄O₆, SO₃. Add Br water. A white precipitate proves SO₃.</p>	

Silver Nitrate Group

Acidify a portion of the solution for the acid analysis with dilute HNO₃, and add AgNO₃ solution, drop by drop, as long as a precipitate forms. Filter.

<p>Precipitate.—The silver salts of the group.</p>		<p>Filtrate.—The Barium and Soluble Groups. Pour a few drops on a white porcelain tile, and place a drop of NH₄OH by means of a glass rod carefully on the solution. A colored ring will appear.</p>
<p>Color</p>	<p>Inference</p>	
White	Cl ⁻ , CN ⁻ , ClO ⁻ , SCN ⁻	
Light yellow	Br ⁻ , Fe(CN) ₆ ⁴⁻ , I ⁻	
Orange yellow	Fe(CN) ₆ ³⁻	
Black	S ²⁻ sulfides, thiosulfates	
<p>Add NH₄OH to the precipitate after washing by decantation; shake thoroughly and filter.</p>		
<p>Residue.—Ag salts of Br⁻, Fe(CN)₆³⁻, Fe(CN)₆⁴⁻, ClO⁻, SCN⁻, I⁻.</p>	<p>Filtrate.—Cl⁻, CN⁻. Add dil. HNO₃ and boil to expel—CN⁻.</p>	<p>Color Inference</p>
<p>See method of analysis un- der HNO₃ Group. Part III.</p>	<p>Residue.— AgCl.</p>	<p>Yellow H₃AsO₃ or H₃PO₄ Brown H₃AsO₄ Red H₃CrO₄ White H₂SO₃, HPO₃, etc.</p>

Note.—A colored halide insoluble in strong NH₄OH is an iodide of silver. AgCl is white and is easily soluble in NH₄OH. AgBr is slightly soluble.

Soluble Acid Group and Organic Acids

Members indicated by the H₂SO₄ acid test.

§ 40

TABLE VIII

ANALYSIS OF THE BARIUM REAGENT OR SULFATE GROUP

Detection of the Sulfate Group

Acidify a 2-3 cc. portion of the solution diluted to about 10 cc. by adding acetic acid a few drops at a time until the solution reddens blue litmus paper. Add about 2 cc. in excess and filter if a precipitate forms. To the clear solution add a few drops of barium chloride reagent. A precipitate indicates the presence of the sulfate group. Should the solution remain clear add a few cubic centimeters of calcium chloride reagent and allow to stand. A slight turbidity must be regarded as indicative of the group.

Note.—Calcium fluoride and calcium oxalate are less soluble than the corresponding barium salts.

Detection of Sulfate, Sulfite, Fluoride and Oxalate

Preliminary Tests for Sulfide and Thiocyanate

(a) *Sulfide.*—Dilute about 2 cc. of the carbonate solution to 5 cc. and add a drop or so of $Pb(NO_3)_2$ reagent. A dark colored precipitate indicates the presence of a sulfide.

(b) *Thiocyanate.*—Test a second portion for thiocyanate according to the procedure given under the Silver Reagent or Chloride Group.

If tests (a) or (b) indicate the presence of sulfide or thiocyanate remove these as follows: To a 5-10 cc. portion of the carbonate solution add $AgNO_3$ reagent drop by drop until no further precipitation occurs. Shake well and filter off the precipitate. Test the filtrate for the sulfate group elements mentioned above.

Slightly acidify the solution with dilute HCl (litmus paper test). Filter if a precipitate forms. Add to the filtrate a few cubic centimeters of $BaCl_2$ reagent. Filter if a precipitate forms.

Precipitate. — $BaSO_4$, white. Proves SO_4^{--} .	Filtrate. —May contain sulfite, chromate, fluoride, oxalate. Add bromine water until the solution smells of Br. Heat gently. A sulfite will be oxidized to sulfate causing precipitation of $BaSO_4$. Filter if a precipitate forms.
--	--

Precipitate. — $BaSO_4$. Proves sulfide, SO_3^{--} .	Filtrate. —May contain fluoride, oxalate, chromate, etc. Add a few cubic centimeters of sodium acetate reagent, and about 5-10 cc. of $CaCl_2$ reagent. A white precipitate indicates the presence of a fluoride or an oxalate. See special tests for these. Wash the precipitate with water, rejecting the solution. Divide in two portions and test one portion for fluoride and the other for oxalate. A yellow precipitate shows the presence of chromate.
---	---

ANALYSIS OF THE SILVER REAGENT OR CHLORIDE GROUP

Detection of the Chloride Group

Dilute a small portion (2-3 cc.) of the Na_2CO_3 solution with 4-5 times its volume of water; reduce chlorates and hypochlorites to chlorides by adding a few drops of NaNO_2 solution; acidify by adding dropwise HNO_3 (litmus test) and add a few drops of AgNO_3 reagent. A precipitate forming indicates the presence of the group. Cl^- , Br^- , I^- , CN^- , SCN^- , $\text{Fe}(\text{CN})_6^{3-}$, $\text{Fe}(\text{CN})_6^{4-}$.

Detection of Ferro and Ferricyanide and Thiocyanate

Acidify a fresh portion of the Na_2CO_3 solution (If NaCN is present) with HCl added dropwise (litmus paper test) and add several drops of FeCl_3 solution and filter if a precipitate forms.

Precipitate. — $\text{Fe}_4(\text{Fe}(\text{CN})_6)_3$, deep blue, Prussian blue.	Filtrate. —A red color is obtained in presence of $\text{Fe}(\text{SCN})_3$. This color may be masked by the brown color produced by an excess of FeCl_3 in presence of CN^- . Extract the $\text{Fe}(\text{CNS})_3$ by shaking in a separatory funnel with a little ether. The ether layer will be colored red by $\text{Fe}(\text{CNS})_3$ if this is present.
--	--

To the water solution from above add a few drops of SnCl_2 reagent. The excess of FeCl_3 is reduced and reacts with the ferricyanide, if this is present, forming the blue compound $\text{Fe}_3(\text{Fe}(\text{CN})_6)_2$, Turnbull's blue.

Detection of Chloride, Bromide, Iodide, Sulfocyanate

1. Since cyanides, ferrocyanide and ferricyanide give white precipitates similar to that of a chloride with the silver reagent they are removed before testing for the halogens. Cyanides may be decomposed by boiling the solution acidified with HNO_3 . They may also be removed by precipitation with nickel or cobalt salts, the halide salts being soluble.

Ferrocyanides and ferricyanides may be removed by drying the precipitate of silver reagent in a porcelain crucible and then heating to dull redness. The residue is cooled, a piece of zinc now added together with a few drops of dilute H_2SO_4 . After the reaction subsides, dilute, filter and add a few drops of HNO_3 and AgNO_3 reagents. The halogens will precipitate free from cyanides.

Sulfides would mask the colors of the halogens. S^- ions are removed by precipitation with lead reagent, with formation of PbS .

In presence of the interfering anions proceed as follows:

2. *Test for Sulfide.*—Dilute a small portion (4-5 cc.) of the Na_2CO_3 solution containing the chloride group, with an equal volume of water. Add a drop or so of $\text{Pb}(\text{NO}_3)_2$ reagent. A dark colored precipitate indicates the presence of S^- . If present remove by adding additional $\text{Pb}(\text{NO}_3)_2$ reagent, a few drops at a time, shaking the solution with each addition to coagulate the precipitate. When additional reagent no longer produces a dark colored precipitate, filter. (Avoid adding a large excess of the lead reagent.) Reject the precipitate PbS . Save the filtrate.

Acidify the filtrate with acetic acid (litmus paper test) and add a few drops of the acid in excess. Filter, if a precipitate forms. (This may be due to free S from thiosulfate, or H_2SiO_3 from silicate, $\text{Ni}(\text{CN})_2$, $\text{Ag}_2(\text{CN})_2$, hydroxides of Sn or Sb .) Reject the precipitate and save the filtrate.

If cyanides or ferricyanide or ferrocyanide are present remove with nickel reagent as follows: To the solution add $\text{Ni}(\text{NO}_3)_2$ reagent in small portions, shaking the mixture with each addition. When precipitation is complete, filter. Save the filtrate for testing the halogens.

3. *Precipitation of the Halides.*—Treat the solution, free from interfering substances, as follows: Add 2–3 cc. of HNO_3 and then AgNO_3 reagent in sufficient amount to completely precipitate the halogens (1–10 cc.) shaking the solution with each addition of the reagent. A white precipitate may be due to Cl^- or SCN^- combined with Ag^+ . A yellow color is produced by Br^- and I^- combined with Ag^+ . A black precipitate may be due to the incomplete removal of S^- . If the precipitate is black, add 2–3 cc. HNO_3 and boil until the color lightens with removal of S^- . Filter. Save the precipitate.

4. *Separations.*—*Removal of the Excess of Silver Reagent.*—Transfer the precipitate to an evaporating dish. Add a few cubic centimeters of NH_4OH reagent and then $(\text{NH}_4)_2\text{S}$ reagent a few drops at a time, heating the solution with each addition to coagulate the Ag_2S precipitate. When sufficient reagent has been added to remove the excess of silver reagent, i.e., Ag uncombined with the halogens, filter and reject the precipitate Ag_2S . Save the filtrate.

Evaporate the filtrate until free of NH_3 odor. Filter if cloudy. Add a few drops of HNO_3 and then 5–10 cc. of $\text{Fe}(\text{NO}_3)_3$ reagent. Transfer to a small separatory funnel and add 2–3 cc. of CCl_4 and shake. Allow the CCl_4 to separate from the water. If an *iodide* is present the CCl_4 will be colored *purple*. If *thiocyanate* is present the water solution will be colored *red*. If *iodide* is indicated, extract the water solution with additional CCl_4 . Allow the CCl_4 to separate each time from the water layer and draw off the CCl_4 . When the color of the extract becomes faint, transfer the water solution to a beaker or casserole and boil to expel any remaining iodine.

Vapor.—Purple I° . | **Solution.**—May contain $\text{Fe}(\text{CNS})_3$, HBr , HCl and the excess $\text{Fe}(\text{NO}_3)_3$.

Cool and add to the mixture 2–3 cc. HNO_3 and then drop by drop KMnO_4 reagent until the solution is colored purple. Avoid more than 2–3 drops in excess. Transfer to a separatory funnel and add CCl_4 reagent (1–2 cc.) shake and allow to separate from the water solution. The CCl_4 layer will be colored yellow or orange if a bromide was present in the solution. Draw off the CCl_4 layer from the water solution.

CCl_4 layer yellow or orange indicates Br° . | Water solution contains chloride and $\text{Fe}(\text{CNS})_3$ etc. Transfer to a beaker or flask. Dilute to 25–50 cc. Boil to expel any remaining Br , adding more KMnO_4 if the purple color fades out on boiling.

Vapor.—Reddish brown Br° . | Water solution will contain chloride, etc. When the Br° has been expelled allow the solution to cool and add, dropwise, sufficient NaNO_2 to destroy the purple color of the KMnO_4 and to dissolve any brown precipitate of MnO_2 that may have formed. Now add AgNO_3 reagent. A *white* precipitate will form if a *chloride* is present. *AgCl, white.*

§ 42. Analysis of the Soluble Acid or Nitrate Group

If the solution is colored red, a permanganate is indicated. Decolorize by adding H_2O_2 .

Evaporate a portion of the solution on the water bath to dryness and test the residue for chlorate.

If a chlorate is present, to a second portion add sodium sulfite (to reduce the chlorate) and boil. Cool and test for nitric acid.

NOTES ON THE ANALYSIS OF ANIONS

§ 43. 1. *Preparation of the Solution.*—The treatment with sodium carbonate by boiling or fusion, as the case may require, forms by double decomposition the water soluble sodium salts of the acids and the water insoluble carbonates of many of the basic constituents, the removal of which is desirable. A number of the metals, for example, would interfere in the detection of the acids on account of the colors produced by their ions or by the precipitates that would form in the solutions during the tests if these basic substances were present. Mercurous mercury, silver and lead compounds would precipitate in the detection of the sulfate acid group. Copper, nickel, chromium, cobalt and iron would interfere by coloring the solution. The double decomposition is not always complete, for a number of sulfides are not decomposed by the carbonate treatment, for example, the sulfides of the iron group. Provision is made for detection of the sulfide acid radical by testing the residue of the carbonate fusion by treating with metallic zinc and hydrochloric acid and testing the H_2S gas that evolves. A number of phosphates are only slightly acted upon by Na_2CO_3 . PO_4 is detected according to the procedure outlined under the metals in the ammonium-sulfide group. The halides of silver are also but slightly affected by boiling with Na_2CO_3 solution, and $BaSO_4$ also resists double decomposition. The reaction with high temperatures of fusion, however, brings about the desired double decomposition or metathesizing action of Na_2CO_3 .

Elements which form both basic and acidic constituents may be present in the acid solution, for example the solution may contain sodium chromate, sodium aluminate, combinations of sodium and antimony, arsenic, tin, copper, manganese. These substances will not be considered under the acid tests.

Boiling with sodium carbonate and the action of constituents in the solution upon each other would cause changes in certain acid radicals. Hypochlorites would decompose forming chlorates and chlorides, the presence of reducing agents would affect chromates, ferricyanides, chlorates, etc. Likewise oxidizing agents would change sulfites, thiosulfates, sulfides, etc.

2. *Separations—Preliminary Tests of the Groups.*—Both barium and calcium are used in the group test for the sulfate group since the barium test for fluoride or oxalate is not sufficiently delicate for detecting small amounts. Consult, on the back cover of this text, the comparative table of solubilities of BaF_2 , CaF_2 , BaC_2O_4 , CaC_2O_4 . A slight turbidity is considered an indication of the presence of the group.

In the test for the chloride group the color of the precipitate may show the presence of certain anions: AgCl , $\text{Ag}_2(\text{CN})_2$, AgSCN and $\text{Ag}_4\text{Fe}(\text{CN})_6$ are white; AgBr is light yellow, AgI is yellow, Ag_2S is black. Consult the table on the back cover of this text for the comparative solubilities of the silver compounds of the chloride group.

Study the section on acids under the chapter on the systematic analysis of substances.

§ 44

CLASSROOM REVIEW OF THE ANIONS

1. In the preparation of the acid solution by the addition of Na_2CO_3 a precipitation generally takes place. Of what general class of substances is it apt to be composed?
2. How can phosphorus or sulfur be detected in an alloy?
3. Give a method by which BaSO_4 or an insoluble silicate may be rendered soluble.
4. In precipitating arsenic acid why is it necessary to acidify with HCl ?
5. Give a method by which a chromate, and oxalate, and a sulfate may be separated.
6. If a sulfide and sulfite are both present in a sample, what product is formed when the material is acidified?
7. How would you distinguish between a carbonate and a sulfite if both are present in solution?
8. If a green color results when the gases evolved from an unknown, acidified with sulfuric acid are passed into a solution of potassium dichromate, what gases are apt to be present?
9. If, on testing for sulfides with lead acetate paper, a yellow color results, what is present in the substance?
10. How can you distinguish between a sulfite and sulfate?
11. How can you distinguish between a nitrite and nitrate?
12. How would you test for oxygen if a perchlorate were present in the substance being analyzed?
13. ClO_2 is removed from a solution of halides on account of its action on free iodine. What is the action?
14. Explain why the difficultly soluble silver halides dissolve in dilute sulfuric acid when zinc is added.
15. From the solubility table devise a method of separating chlorine from a ferrocyanide.
16. How can free chlorine in solution be distinguished from combined chlorine?
17. How would you distinguish between a chloride, a bromide and an iodide?
18. Give a procedure for detecting the halides in a mixture containing the ions—chlorine, bromine and iodine.
19. Give a procedure for detecting H_2S in an insoluble sulfide.
20. How can you distinguish: (a) A ferrocyanide from a ferricyanide; (b) A cyanide from a carbonate?

21. Give a procedure for testing a thiocyanate.
22. What is the effect of concentrated sulfuric acid on a chlorate?
23. What is the effect of hydrochloric acid on a permanganate?
24. How can you distinguish free nitric acid from a solution of its salt?
25. Devise a method for separating the acid radicals: CO_3^{2-} , I^- , and NO_3^- .

Anion Reactions

Complete and balance the following equations:

A. Sulfate Group

- (a) $\text{BaCl}_2 + \text{Na}_2\text{CO}_3 = \text{BaCO}_3 +$
- (b) $\text{CaCO}_3 + \text{HCl} = \text{CO}_2 +$
- (c) $\text{Ca}(\text{OH})_2 + \text{CO}_2 = \text{CaCO}_3 +$
- (d) $\text{BaCl}_2 + \text{CO}_2 = \text{BaCO}_3 +$
- (e) $\text{BaCl}_2 + \text{H}_2\text{SO}_4 = \text{BaSO}_4 +$
- (f) $\text{BaCl}_2 + \text{K}_2\text{CrO}_4 = \text{BaCrO}_4 +$
- (g) $\text{Pb}(\text{C}_2\text{H}_3\text{O}_2)_2 + \text{K}_2\text{CrO}_4 = \text{PbCrO}_4 +$
- (h) $\text{K}_2\text{CrO}_4 + \text{AgNO}_3 = \text{Ag}_2\text{CrO}_4 +$
- (i) $\text{BaCl}_2 + \text{H}_3\text{PO}_4 + \text{NH}_4\text{OH} = \text{Ba}_3(\text{PO}_4)_2 + \text{NH}_4\text{Cl} +$
- (j) $\text{Na}_3\text{PO}_4 + (\text{NH}_4)_2\text{MoO}_4 = (\text{NH}_4)_3\text{PO}_4 \cdot 12\text{MoO}_3 +$
- (k) $\text{Na}_3\text{PO}_4 + \text{AgNO}_3 = \text{Ag}_3\text{PO}_4 +$
- (l) $\text{BaCl}_2 + \text{NaF} = \text{BaF}_2 +$
- (m) $\text{CaCl}_2 + \text{NaF} = \text{CaF}_2 +$
- (n) $\text{BaCl}_2 + \text{Na}_2\text{SO}_3 = \text{BaSO}_3 +$
- (o) $\text{Na}_2\text{SO}_3 + \text{HCl} = \text{SO}_2 +$
- (p) $\text{Na}_2\text{B}_4\text{O}_7 + \text{BaCl}_2 + \text{H}_2\text{O} = \text{Ba}(\text{BO}_2)_3 + \text{H}_3\text{BO}_3 + \text{NaCl}$
- (q) $\text{CaCl}_2 + (\text{NH}_4)_2\text{C}_2\text{O}_4 = \text{CaC}_2\text{O}_4 +$
- (r) $\text{H}_2\text{C}_4\text{H}_4\text{O}_6 + \text{H}_2\text{SO}_4 = \text{H}_2\text{SO}_4 + \text{H}_2\text{O} + \text{CO}_2 + \text{C}$
- (s) $\text{Na}_2\text{SiO}_3 + \text{BaCl}_2 = \text{BaSiO}_3 +$
- (t) $\text{SiO}_2 + \text{HF} = \text{SiF}_4 +$
- (u) $\text{Na}_2\text{S}_2\text{O}_3 + \text{BaCl}_2 = \text{BaS}_2\text{O}_3 +$
- (v) $\text{Na}_2\text{S}_2\text{O}_3 + 2\text{HCl} = \text{SO}_2 + \text{S} +$
- (w) $\text{Na}_2\text{S}_2\text{O}_3 + \text{I} = \text{Na}_2\text{S}_4\text{O}_6 + \text{NaI}$

B. Chloride Group

- (a) $\text{NaCl} + \text{AgNO}_3 = \text{AgCl} +$
- (b) $\text{NaBr} + \text{AgNO}_3 = \text{AgBr} +$
- (c) $\text{KBr} + \text{Cl}_2 = \text{Br}_2 +$
- (d) $\text{KBr} + \text{KMnO}_4 = \text{Br}_2 +$

Hint— $(2\text{KMnO}_4 + 16\text{HCl} = 2\text{KCl} + 8\text{H}_2\text{O} + 2\text{MnCl}_2 + 5\text{Cl}_2)$

- (e) $\text{NaI} + \text{AgNO}_3 = \text{AgI} +$
 (f) $\text{KI} + \text{K}_2\text{Cr}_2\text{O}_7 + = \text{I}_2 +$
 $(2\text{CrO}_3 + 6\text{KI} = \text{Cr}_2\text{O}_3 + 3\text{K}_2\text{O} + 3\text{I}_2)$
 (g) $\text{KI} + \text{Fe}(\text{NO}_3)_3 = \text{I}_2 + \text{Fe}(\text{NO}_3)_2 +$
 (h) $\text{Na}_2\text{S} + \text{AgNO}_3 = \text{Ag}_2\text{S} +$
 (i) $\text{FeS} + \text{HCl} = \text{H}_2\text{S} +$
 (j) $\text{K}_4\text{Fe}(\text{CN})_6 + \text{AgNO}_3 = \text{Ag}_4\text{Fe}(\text{CN})_6 +$
 (k) $\text{K}_4\text{Fe}(\text{CN})_6 + \text{FeCl}_3 = \text{Fe}_4(\text{Fe}(\text{CN})_6)_3 + 12\text{KCl}$
 (l) $\text{K}_3\text{Fe}(\text{CN})_6 + \text{AgNO}_3 = \text{Ag}_3\text{Fe}(\text{CN})_6 +$
 (m) $\text{K}_3\text{Fe}(\text{CN})_6 + \text{FeSO}_4 = \text{Fe}_3(\text{Fe}(\text{CN})_6)_2 + 3\text{K}_2\text{SO}_4$
 (n) $\text{KCNS} + \text{AgNO}_3 = \text{AgCNS} +$
 (o) $\text{KCNS} + \text{FeCl}_3 = \text{Fe}(\text{CNS})_3 +$
 (p) $\text{KCN} + \text{AgNO}_3 = \text{AgCN} +$

C. Soluble Group

- (a) $\text{NaNO}_3 + \text{FeSO}_4 + \text{H}_2\text{SO}_4 = \text{Fe}_2(\text{SO}_4)_3 + 4\text{NO}$
 (b) $\text{NaNO}_2 + \text{H}_2\text{SO}_4 = \text{NaHSO}_4 + \text{HNO}_2$
 (c) $\text{HNO}_2 = \text{HNO}_3 + 2\text{NO} + \text{H}_2\text{O}$
 (d) $\text{NO} + \text{O}(\text{air}) = \text{NO}_2$
 (e) $\text{HNO}_2 + \text{CS}(\text{NH}_2)_2 = \text{N}_2 + \text{HSCN} + \text{H}_2\text{O}$
 (f) $\text{NaC}_2\text{H}_3\text{O}_2 + \text{H}_2\text{SO}_4 = \text{H} \cdot \text{C}_2\text{H}_3\text{O}_2 +$
 (g) $\text{KClO}_3 + \text{H}_2\text{SO}_4 = \text{KHSO}_4 + \text{HClO}_4 + 2\text{ClO}_2 + \text{H}_2\text{O}$
 (h) $\text{KMnO}_4 + \text{FeSO}_4 + \text{H}_2\text{SO}_4 = \text{Fe}_2(\text{SO}_4)_3 +$
 (i) $\text{KMnO}_4 + \text{SO}_2 + \text{H}_2\text{O} = \text{H}_2\text{SO}_4 +$
 (j) $\text{KMnO}_4 + \text{K}_2\text{C}_2\text{O}_4 + \text{H}_2\text{SO}_4 = \text{CO}_2 +$

PART III

SYSTEMATIC ANALYSIS OF SUBSTANCES

§ 45. Preparation of the Solution.—1. *Liquids*.—Test the solution with litmus paper to ascertain whether it is acid or alkaline. If alkaline, warm a portion gently and note whether ammonia is present. Carefully neutralize with HNO_3 and observe whether the solution effervesces when it becomes acid. Effervescence indicates the presence of a volatile acid: CO_2 , H_2S , SO_2 , HCN , etc.

Evaporate a small portion in a test tube to dryness and ignite gently to observe whether organic matter is present. Darkening of the residue accompanied with an odor of charring organic matter indicates organic substances. If these are present the solution must be evaporated to dryness and treated according to the directions given for destroying organic matter under Solids.

Organic matter being absent, 10–20 cc. of the solution is neutralized with acid or ammonia as the case may require. Two cc. of strong HCl are added and the solution examined for the metals, following the direction under the tables for separations.

2. *Solids*.—We have learned that the identification of elements depends largely upon testing these in ionic state in water or acid solutions. Many of the commercial salts are soluble in water. Practically all salts of Na, K, Li, NH_4 , nitrates, nitrites, chlorates, chlorides, bromides, iodides, sulfates, acetates are soluble, with the exception of basic nitrates, chlorides, bromides and iodides of silver, lead and monovalent mercury and copper, sulfates of Ba, Ca, Sr, Pb, Hg (monovalent) and basic acetates of some elements. With the exception of alkali salts all carbonates, phosphates, borates, oxalates, tartrates, arsenates and arsenites are insoluble. Natural products, with a few exceptions, are insoluble; ores,

minerals and igneous products requiring special treatment to effect solution. The natural carbonates, such as limestone, dolomite and witherite dissolve in HCl, silicates generally require treatment with HF or like the sulfates of Ba, Ca, Sr require fusion with Na_2CO_3 to effect their decomposition. The material examined should be finely divided by grinding in a mortar if it is friable; or by filing or hammering into thin sheets if it is a metal or alloy.

Decomposition may be conducted in a porcelain casserole or in a pyrex pear-shaped flask of about 250–350 cc. capacity. This latter vessel, variously known as the decomposition flask, Low's flask or copper flask, affords a convenient and rapid means of decomposition and evaporation. The flask is held by means of a heavy wire holder directly over the naked flame as shown in Fig. 8. The vessel is tilted from the vertical position and kept in motion above the flame. Practically no material is lost by "bumping" as is apt to occur in casseroles or beakers. Evaporations with corrosive acids should be conducted in a *well-ventilated hood*.

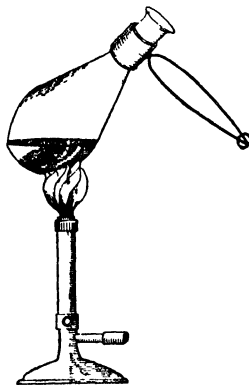

FIG. 8.—Decomposition of Substances.

§ 46. Preliminary Examination of Solids.—Clues as to the composition of substances can be obtained, often, from the appearance and color of the solids, for

example, copper, nickel, cobalt salts, chromates, permanganates, ferrous and ferric salts are colored. A large number of salts, however, are white in their powdered form and require magnification of their particles for distinguishing features, where such exist. Certain tests are of value in recognizing certain constituents—blowpipe tests, flame tests, borax bead and microcosmic salt fusions, combustion tube tests, etc. The dry assay methods or fire tests are of special value in detecting the constituents of

minerals and have been developed into a systematic scheme in mineral analysis. The tables in the Appendix serve as an introduction to this scheme, which requires a more extended course than is offered here. In our present course our time will be fully occupied in getting a grasp of the so-called "wet methods" for distinguishing the more common substances, and a few fire tests that supplement these methods.

1. *Test for Ammonia*.—Place a small amount of the substance in a test tube, add a little NaOH solution and heat. The odor of NH_3 will be observed if an ammonium salt is present.

2. *Test for Volatile Acids*.—Acidify a small portion in a test tube. Effervescence indicates the presence of CO_2 , H_2S , SO_2 , HCN . See identification tests under the chapter on Acids.

3. *Test for Organic Matter*.—Place a small portion in a hard glass test tube and heat. If a black residue results on ignition, accompanied by an odor of charring (recall the odor of burning sugar), organic matter is indicated. Decomposition and solution of the material should be effected by the procedure under non-metallic salts and compounds—"Organic Matter Present." Salts of Cu, Ni, Co, etc., turn black on heating, due to the formation of oxides of these elements, so that darkening alone does not indicate organic matter.

4. *Test for Phosphate*.—See procedure under Group III of the metals.

§ 47. Procedures for Decomposition and Solution of Solids.—

A. Non-Metallic Solids.

1. *Organic Matter Present*.—In a small pyrex decomposition flask place 2–3 cc. of the finely powdered substance and add about 10 cc. of strong H_2SO_4 (d. 1.84). Heat gently until the material chars and darkens, allow to cool and add in small portions an equal volume of strong HNO_3 (Hood). Holding the flask at an angle from the vertical, heat the mixture over the naked flame to boiling until white fumes of H_2SO_4 appear. If the solution is still dark

colored, allow to cool, add more HNO_3 and repeat the heating. When the solution becomes a pale yellow evaporate off the excess of H_2SO_4 carrying the evaporation to a moist residue. Add 2 cc. of dilute H_2SO_4 (1 : 1), dilute to 25–30 cc. with water, boil and filter if a residue remains. Examine the solution for the metals according to the outlines for separation of the bases. Treat the residue by the fusion method described under “Residue Insoluble in Acids.”

2. *Organic Matter Absent.*—(a) Place about 1–2 cc. of the finely divided substance in a pyrex decomposition flask, add about 25 cc. of water and heat to boiling. If the material dissolves, acidify and proceed with the analysis of the metals according to directions given for separation in the tables. If the material remains insoluble or only partly dissolves add concentrated HNO_3 , drop by drop, until the solution reddens litmus paper and then 5 cc. more. Heat to boiling, evaporating the mixture to small volume (moist residue) over the naked flame. Dilute with a few cubic centimeters of water, heat and filter if a residue remains. Examine the solution for the metals.

(b) *Residue Insoluble in Nitric Acid.*—The residue from HNO_3 may contain one or more of the following: sulfides of the metals or free S, H_2SnO_3 , Sb_2O_5 , Fe_2O_3 , Al_2O_3 , MnO_2 , PbO_2 , PbCrO_4 , BaCrO_4 , Cr_2O_3 , PbSO_4 , BaSO_4 , CaSO_4 , SrSO_4 , CaF_2 , SiO_2 and silicates.

Add 5–10 cc. of strong HCl (d. 1.19) and evaporate to pastiness. Add 5 cc. more of HCl , heat gently and then add an equal volume of water. Boil and filter if a residue remains. Examine the solution for the metals.

Note.—First addition of HCl forms aqua regia with oxidizing action on sulfides. The second addition of strong HCl has a reducing solvent action on SnO_2 , Fe_2O_3 etc.

(c) *Residue Insoluble in Aqua Regia—Fusion Method.*—Fold together the walls of the filter paper enclosing the residue, remove from the funnel and wind the free end of a platinum wire around

this. The wire is attached to a glass rod. Hold the paper and its contents over a free flame until the paper ignites and allow to burn over a thin spun nickel crucible (25–30 cc. capacity) allowing the ashes to drop into the crucible. Mix the residue in the crucible with twice its volume of an alkali flux consisting of equal parts of Na_2CO_3 and K_2CO_3 . Heat over a free flame until the flux melts and the solution becomes homogeneous. If black particles remain add 0.2–0.3 cc. of NaNO_3 and continue the heating for 10–15 minutes. Allow to cool and place the crucible and its contents in a beaker containing about 50 cc. of water. Boil until the mass disintegrates. Filter off the carbonates of the metals. The solution may contain SO_4 , PO_4 , F, SiO_2 , Cl, As, Sb, Sn, Al, Cr, Mn combined with the Na and K. Reserve this for examination of these substances. See note under the following procedure.

(d) *Carbonate Residue*.—Transfer to a pyrex beaker, add a little water and then add, drop by drop, dilute HNO_3 until the solution is acid (litmus paper test). Most of the basic constituents of the acid insoluble material will be found in this solution.

Note.—Test the action of a small portion of this solution in a small portion of the filtrate of (c), adding enough of (d) to give an acid reaction. If the solution remains clear, mix the two solutions and acidify with HNO_3 . Test for the metals in the combined solutions. If a cloudiness is produced, which remains on acidification, run the two solutions separately for the elements.

To remove SiO_2 evaporate (d) to dryness, add 2–3 cc. strong HCl (d. 1.19); again evaporate, take up with 20–25 cc. of water and filter. Should Ag be present it will remain with the SiO_2 residue.

B. Metallic Substances—Elements and Alloys.

Place about 0.5 gr. of the alloy filings or thin sheet in a decomposition flask, add 10 cc. of dilute HNO_3 (1 : 1) and heat gently. Should a residue remain, add 10 cc. of strong HCl (d. 1.19) and continue the heating, evaporating the solution to near dryness. Now add 2 cc. HCl (d. 1.19) 10 cc. of water, boil and filter. The residue may be a member of the silver group and SiO_2 ; the filtrate is examined for the group elements, 2 and 3.

Note.—Certain ferrous alloys, ferrotungsten, ferrochromium, ferrosilicon, etc., require special treatment to effect solution. Consult a test on quantitative analysis.

C. Preparation of the Solution for Analysis of the Acids, the Anions.

—(See also Table VI at the close of the chapter on Acids.)

(a) *Salts.*—Place 2–3 cc. of the powdered salt in a decomposition flask and add twice its volume of Na_2CO_3 powder and 20–30 cc. of water. Boil gently for 15–20 minutes, adding water to replace that which evaporates. Filter and wash the residue.

The residue contains the carbonates of the metal. The filtrate contains the sodium salts of the acids. Examine this.

Note.—Sulfides of certain elements, for example, pyrites, do not readily decompose with the above treatment. The sulfide anion should be tested for in the original sample, by distilling H_2S from the sample treated with a little granulated zinc (0.2 g.) and HCl . Carbonic acid is also tested for in the original material.

(b) Minerals, ores, etc., are best decomposed by fusion with Na_2CO_3 . The procedure is similar to that described under *A2(c)*, and the acids tested for in the water extract of the Na_2CO_3 fusion.

Brief directions for the procedures recommended for the examination of the solution *C* for acids will be found following the outlines for examination of the cations in succeeding pages. See also the chapter on acids for individual tests, both in the preliminary tests and the tables that follow.

SUMMARY OF ANALYSIS OF THE CATIONS OR BASIC ELEMENTS, THE METALS

§ 48. *Silver or Hydrogen-Chloride Group.*—The residue insoluble in dilute HCl that has been filtered off is tested for silver, mercurous mercury and lead, (AgCl, HgCl and PbCl₂) according to the scheme for the separation given in the first group. Table I.

2. *Hydrogen-Sulfide Group.*—The filtrate from the silver group containing free HCl is diluted to about 100 cc. and saturated with H₂S gas, precipitation of arsenic occurs more rapidly if the solution is hot. After saturation with H₂S, dilute the solution as stated in the scheme for analysis of the hydrogen-sulfide group, and again saturate with H₂S. Precipitation is more rapid if conducted under pressure.

Filter off the precipitate, and examine according to the scheme for analysis of the hydrogen-sulfide group elements, Table II, first making a separation with ammonium polysulfide of the copper and tin subdivisions. The filtrate from the H₂S precipitate is saved for the tests of subsequent groups. It is important to resaturate this filtrate to be certain that the precipitation of the H₂S group elements is complete. If a precipitate forms, filter off and add to the sulfides above mentioned. Arsenic in the pentavalent form precipitates slowly and may pass into this filtrate if the H₂S treatment is not thorough.

3. *Ammonium-Sulfide Group.*—The filtrate from the hydrogen-sulfide group is boiled to expel H₂S. Should a precipitate form on boiling, filter off and reject the precipitate. To the clear filtrate add NH₄OH until the solution turns red litmus blue and the solution smells of NH₃. Observe whether a precipitate forms. It is often possible to recognize the presence of iron, aluminum and chromium at this stage. Now saturate the solution with H₂S and

filter off the ammonium-sulfide group elements. Save the filtrate for examination of the subsequent group elements.

Examine the precipitate according to directions given for the ammonium-sulfide group, Table III. Keep in mind the test for phosphate by ammonium molybdate. If phosphates are present, all of the following group will be present with the ammonium-sulfide group, precipitation of the phosphates occurring when ammonia is added and the solution becomes alkaline. Should phosphates be present the PO_4 must be removed by addition of FeCl_3 , and iron must be tested for in a preliminary test before adding the ferric reagent to remove PO_4^{\equiv} .

4. Ammonium-Carbonate Group.—The filtrate from the ammonium-sulfide group is examined for the subsequent groups. Since this solution must be concentrated it is advisable to start this concentration during the examination of the previous group, or the concentration may be carried out rapidly in a pyrex flask, held by means of tongs in an inclined position over the naked flame. (See Fig. 8.) When the volume of the solution is reduced to 15–25 cc. it will be generally cloudy due to free sulfur and sulfides of previous groups. BaSO_4 may be present due to SO_4 forming in the reaction. Should the later test for Ba be negative look for this in the original solution by testing a small portion with H_2SO_4 and examining for barium any precipitate that may form.

The concentrate, filtered clear, is made alkaline with ammonia. (Red litmus paper test.) Ammonium-carbonate reagent is added in small portions as long as it causes precipitation to take place. (Allow the precipitate to settle and test with a few drops of the reagent to observe this.) Heat gently to coagulate the precipitate and filter. Examine the precipitate according to the scheme for analysis of the ammonium-carbonate group elements, Table IV. Save the filtrate for the soluble group.

5. The Soluble Basic Group.—Magnesium, sodium and potas-

sium are tested for according to the directions given under this group, Table V. After the removal of magnesium as a phosphate, it is necessary to evaporate the filtrate from magnesium to dryness. The excess of phosphate is removed as well as any traces of elements of previous groups. The water extract of the residue from which ammonium salts have been expelled by heat, is examined for sodium and potassium. Recognition of potassium by the flame test requires some practice. Sodium invariably interferes as traces of sodium colors the flame yellow. The blue glass screen is necessary to cut out the yellow.

Flame tests may be conducted on the original sample. The spectroscope is of special value in recognizing barium, strontium, calcium and sodium. Recognition of potassium by the spectroscope is less satisfactory as the blue line due to potassium is seen with difficulty, as it lasts but an instant in the usual test.

OUTLINE SEPARATION OF THE GROUPS

To the solution of all Groups, add HCl and filter.

Precipitate Group 1—Silver Group.—Filtrate—Groups 2, 3, 4 and 5. Filtrate—Saturate with H_2S and filter.

Precipitate Group 2—Copper and Tin, etc.—Filtrate—Groups 3, 4 and 5. Filtrate—Add NH_4OH and H_2S or $(NH_4)_2S$ and filter.

Precipitate Group 3—Iron and Aluminum, etc.—Filtrate—Groups 4 and 5. Filtrate—Add NH_4OH and $(NH_4)_2CO_3$.

Precipitate Group 4—Barium, etc.—Filtrate—Group 5 Soluble Group.

Examine each precipitate obtained according to the special scheme for separation of the members of the group.

SUMMARY OF ANALYSIS OF THE ANIONS OR ACID RADICALS

§ 49. 1. *Incompatibilities.*—A hypochlorite boiled with Na_2CO_3 decomposes into a chloride and chlorate upon acidification. In the presence of reducing agents such as arsenite, sulfide, sulfite, stannous salt, ferrous salt, the following changes occur—a ferricyanide is reduced to a ferrocyanide, a permanganate to MnO_2 , hexavalent Cr^6 , in a chromate, to trivalent Cr^3 , a chlorate is reduced to chloride. We would not find a sulfide, sulfite, nitrite, or iodide in an acid solution containing a hypochlorite, permanganate, chromate or ferricyanide. These facts should be remembered in making up mixtures for the so called “unknowns.”

2. *Tests for CO_2 and H_2S in Carbonates and Sulfides.*—If the preliminary test of the original substance with acid indicates

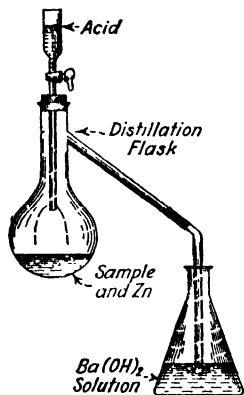

FIG. 9.—Test for CO_2 and H_2S .

CO_2 or H_2S by effervescence, a test for these may be made as follows: Place 1 cc. of the powdered material in a small distilling flask. Connect the outlet tube so that it passes into a solution of $\text{Ba}(\text{OH})_2$ in a small Erlenmeyer flask. By means of a glass stoppered funnel with stem passing through a stopper in the distilling flask add dilute HCl to the material. Heat gently so that the gas evolving passes into the $\text{Ba}(\text{OH})_2$. A white cloudiness is produced in the $\text{Ba}(\text{OH})_2$ in the presence of CO_2 (BaCO_3 formed). Add a few drops of lead acetate solution to the contents of the receiving flask. A black precipitate will form if H_2S was evolved from the material.

3. *Detection of the Acids.*—The solution having been prepared as outlined, proceed as follows for detecting the acids:

4. *Detection of the Barium Reagent Group.*—Dilute a portion of the Na_2CO_3 solution with a little water and very carefully acidify with acetic acid (litmus paper test) adding a few drops in excess. Heat gently to expel CO_2 from the carbonate solution. Filter if a precipitate forms. To the filtrate add a little BaCl_2 solution and slightly larger amount of CaCl_2 solution. A turbidity will be produced in presence of members of the barium chloride group.

5. *Detection of the Silver Reagent Group.*—Dilute a small (2–5 cc.) portion of the Na_2CO_3 solution with about three times its volume of water and add dilute HNO_3 (1 : 1) until the solution reddens litmus paper and then a slight excess. Boil to expel the volatile acids CO_2 , H_2S , SO_2 , etc., that may be present. Cool and add a solution of AgNO_3 . A turbidity results if members of the AgNO_3 group are present. Observe the color of the precipitate.

Note.— AgCl , AgSCN , $\text{Ag}_2(\text{CN})_2$, $\text{Ag}_4\text{Fe}(\text{CN})_6$ are white; $\text{Ag}_3\text{Fe}(\text{CN})_6$ is orange; AgI is yellow, AgBr is faintly yellow.

6. *The Soluble Acid Group* requires individual tests.

§ 50. *Suggestions Regarding Tests for the Acids.*—Although there is no satisfactory scheme for identifying the members of the acid groups as there is in the analysis of the groups of metals, yet it is possible to eliminate considerable work by certain tests which establish the presence or absence of acid radicals possessing certain common characteristics. For example the absence of oxidizing agents in a solution would eliminate a number of acids possessing the property of oxidation, and the same is the case with reducing agents. Likewise the presence of certain basic elements in the solution lead to further conclusions that assist in acid analysis. In certain cases it is possible to make separations utilizing solubilities, oxidation or reduction reactions and the volatility of the acids.

For instructions of the individual tests reference will be made to the chapter on Acids, where the details are given in the preliminary exercises.

1. *Detection of Oxidizing Acids.*—To 2 cc. of the Na_2CO_3 solution of the acids add a saturated solution of MnCl_2 dissolved in strong HCl until the solution reacts acid. A dark brown or black color will be obtained in presence of *permanganate, chromate, ferricyanide, chlorate, nitrate* and *nitrite* (and hypochlorite). Should no darkening occur, these radicals are absent in the solution.

Note.—If an excess of sulfite or sulfide were present in the alkaline solution upon acidification a reduction of the oxidizing constituents would take place preventing oxidation of MnCl_2 , so that no darkening of the solution would take place.

2. *Detection of Reducing Acids.*—Make a mixture of 5 cc. of water, 2 cc. of HCl , 4–5 drops of $\text{Fe}(\text{NO}_3)_3$, and 4–5 drops of $\text{K}_3\text{Fe}(\text{CN})_6$ solutions and add about 2 cc. of the Na_2CO_3 solution containing the acids. The solution should be acid in reaction. (Litmus paper test.) Upon standing, a blue precipitate or greenish blue coloration will result in presence of iodide, sulfite, sulfide, nitrite and ferrocyanide, otherwise these are absent.

3. *Detection of Sulfate, Chromate, Oxalate, Sulfite and Fluoride in a Mixture.*—If the presence of the barium-chloride group has been established the following procedure will establish the presence or absence of the above radicals.

Acidify the Na_2CO_3 solution containing the acids with HCl , adding the acid dropwise until the solution reddens litmus paper. Filter off any precipitate that forms and reject this, saving the filtrate. To the acid solution add about 5 cc. of BaCl_2 solution. A white precipitate is obtained in presence of *sulfate*. (Reject.)

Filter and to the filtrate add bromine solution drop by drop until the solution is saturated with Br . Heat gently. A white precipitate will form in presence of a sulfite. Filter off the precipitate and reject. (Thiosulfate also precipitates here.)

To the filtrate add a few cubic centimeters of sodium acetate reagent and about the same amount of CaCl_2 solution and allow to stand a few minutes. A white precipitate will be obtained in presence of a fluoride or oxalate, a yellow precipitate if a chromate

is present. Filter, saving the precipitate and rejecting the filtrate.

Test for fluoride in a portion of the precipitate. (See individual test for F.)

Test the remaining portion for oxalate by dissolving in hot HNO_3 . In presence of oxalate the addition of KMnO_4 solution will cause effervescence. The gas may be caught in $\text{Ba}(\text{OH})_2$ solution according to the procedure for determining CO_2 . (See subject under Acids.)

4. *Detection of Thiocyanate, Chloride, Bromide and Iodide, in a Mixture.*—If the silver nitrate test indicates the presence of members of this group, transfer the precipitate obtained to a small casserole and continue as follows:

Dissolve the precipitate in a slight excess of NH_4OH and completely precipitate the Ag by adding sufficient $(\text{NH}_4)_2\text{S}$ dropwise, heating, settling the As_2S and adding more of the sulfide until all the Ag is removed from solution. Filter off the Ag_2S and reject. Save the filtrate.

Evaporate the filtrate until NH_3 is expelled and filter.

a. *Test for Iodine and Thiocyanate—Removal of Iodine.*—Pour the filtrate into a separatory funnel, add 5–10 cc. of $\text{Fe}(\text{NO}_3)_3$ to the solution acidified with a few drops of HNO_3 and add 2 cc. of CCl_4 . Shake and allow the CCl_4 to settle. A purple color shows the presence of *iodine*. If iodine is present, repeatedly extract the solution until the CCl_4 extract shows the removal of the greater part of the I. If the aqueous layer is red, *thiocyanate* is shown to be present. Transfer the aqueous layer to a casserole and boil to expel the remainder of the iodine. Cool and pour again into the separatory funnel.

b. *Test for Bromide—Removal of Bromine.*—Add 2–3 cc. of HNO_3 and a few drops of KMnO_4 reagent until the aqueous layer is colored purple. Add 2 cc. CCl_4 , shake and settle. A yellow or orange color in CCl_4 shows the presence of *bromine*. Separate the CCl_4 drawing it off. Transfer the aqueous solution to a cas-

serole and boil to expel Br. If the pink color due to KMnO_4 fades, add more KMnO_4 , drop by drop, keeping the solution slightly colored. With Br removed, test for *chlorine*.

c. Detection of Chloride.—Add chlorine free NaNO_2 reagent, drop by drop, until the pink color of the excess of KMnO_4 disappears and any MnO_2 precipitate has dissolved. Now add AgNO_3 reagent. A white precipitate shows the presence of *chloride*.

Study the table of separations of this group in the chapter on acids following the preliminary tests.

d. Nitrite and Nitrate.—If oxidizing agents are indicated by the special test given for their detection, test for *nitrate* and *nitrite*. See tests in the chapter on Acids under the soluble acid group.

e. Borate.—Make test according to procedure in the Acid chapter.

f. Arsenate and Arsenite.—See subject in the chapter on Acids.

g. Carbonate and Sulfide.—See tests in the beginning of this section in the preliminary examination of the Na_2CO_3 solution.

§ 51

GENERAL SUMMARY OF THE ANIONS

Acids	Detecting Reagents	Reactions Resulting from Test
Acetates	H ₂ SO ₄ (conc.)	Odor of vinegar.
Arsenates	(a) (NH ₄) ₂ MoO ₄ + HNO ₃ (b) Magnesia mixture (c) Reduced on C + Na ₂ CO ₃	Yellow precipitate. White granular precipitate. Garlic odor, arsenic mirror.
Arsenites	(a) Magnesia mixture (b) H ₂ S + HCl	No reaction. Yellow precipitate.
Bromides	(a) H ₂ SO ₄ (conc.) (b) Chlorine water + CS ₂	Red Br vapor. Reddish color, due to Br.
Borates	H ₂ SO ₄ (conc.) + alcohol	Green flame.
Carbonates	Dilute acids	CO ₂ evolved. Limewater test.
Chlorates	(a) H ₂ SO ₄ (conc.) (b) Heated alone	Explosive liberation of Cl + ClO ₂ . O given off.
Chlorides	AgNO ₃ + HNO ₃	White precipitate, sol. in NH ₄ OH.
Chromates	(a) H ₂ SO ₄ (conc.) (b) HCl (a) Alcohol + NaOH	O liberated (sol. yellow to green). Chlorine of HCl liberated. Reduced and Cr(OH) ₃ precipitated.
Cyanides	H ₂ SO ₄ (conc.)	HCN (POISON). Odor, bitter almonds.
Ferricyanides	FeSO ₄ + HCl	Turnbull's blue precipitate.
Ferrocyanides	FeCl ₃ + HCl	Prussian blue precipitate
Fluorides	H ₂ SO ₄ (conc.)	HF gas liberates silicic acid from glass rod with drop of H ₂ O
Hypochlorites	Dilute acids	Cl liberated, yellow gas.
Iodides	(a) H ₂ SO ₄ (conc.) (b) Chlorine water + CS ₂	Violet vapor of iodine. Violet color to CS ₂ .
Nitrates	FeSO ₄ + H ₂ SO ₄ (conc.)	Brown ring.
Nitrites *	Dilute acids	N ₂ O ₃ brown evolved.
Oxalates	H ₂ SO ₄ (conc.)	CO + CO ₂ evolved.
Permanganates	Reducing agents	Decolorized.
Phosphates	HNO ₃ + (NH ₄) ₂ MoO ₄ at 40°	Yellow precipitate.
Silicates	(a) Fused with Na ₂ CO ₃ and HCl added (b) HF	Silicic acid precipitated. SiF ₄ gas liberated.
Sulfates	HCl + BaCl ₂	White precipitate of BaSO ₄ .
Sulfides	Dil. acids	H ₂ S gas blackens Pb(C ₂ H ₃ O ₂) ₂ .
Sulfites	Dilute acids	SO ₂ gas
Sulfocyanides	FeCl ₃	Deep red color.
Thiosulfates	Dilute acids	SO ₂ gas + free S (cloudiness).
Tartrates	Ignited	Char. Odor of burnt sugar.
Organic acids	Heated	Generally char.

* Nitrites + KI + CS₂ = violet color in CS₂ due to free I.

PART IV

§ 52

REAGENTS

Reagents in Solution

Acids

	Specific Gravity	Concentration, Per Cent	Approximate Normality Factor	Volume of Water per 1 Volume of Acid
<i>Inorganic</i>				
Hydrochloric, strong HCl *..	1.20	38.00	12 N †	0
Hydrochloric, dilute HCl....	1.09	19.00	6 N	1
Nitric acid, strong HNO ₃	1.42	70.00	16 N	0
Nitric acid, dilute HNO ₃	1.15	24.00	6 N	2
Sulfuric acid, concentrated or strong H ₂ SO ₄	1.84	95.00	36 N	0
Sulfuric acid, dilute H ₂ SO ₄ ...	1.11	16.00	6 N	5
Sulfurous acid, saturated solution of SO ₂ in water.....	3 N	
<i>Organic</i>				
Acetic acid, glacial.....	1.058	99.00	17 N	0
Acetic acid, dilute.....	1.04	33.00	6 N	2
Tartaric acid, 150 gm. per liter.....	2 N	
<i>Alkalies</i>				
Ammonium hydroxide, NH ₄ OH.....	0.90	28.33 NH ₃	15 N	
Ammonium hydroxide, dilute NH ₄ OH (1 : 3).....	0.97	7.05 NH ₃	4 N	(1 : 3)
Potassium hydroxide, KOH, 281 gm. per liter.....	4 N	
Sodium hydroxide NaOH 178 gm. per liter.....	4 N	

* Strong or saturated.

† A normal solution of a reagent contains in a liter that proportion of its molecular weight in grams which corresponds to one gram of available hydrogen or its equivalent. N. HCl contains its molecular weight (36.47 g.) HCl per liter of solution. N. H₂SO₄ contains one-half of its molecular weight, i.e., 98.08 ÷ 2 = 49.04 g., H₂SO₄ per liter of solution.

From the above reagents lower normalities may be obtained by dilution as desired.

Salt Solutions

	Grams per Liter. Preparation	Approximate Normality
Ammonium acetate, $\text{NH}_4\text{C}_2\text{H}_3\text{O}_2^*$	308	4 N
Ammonium carbonate, $(\text{NH}_4)_2\text{CO}_3^*$	250	6 N
	Add 40 cc. NH_4OH	
Ammonium chloride, NH_4Cl	160	3 N
Ammonium molybdate, $(\text{NH}_4)_2\text{MoO}_4^*$	98	N
Ammonium oxalate, $(\text{NH}_4)_2\text{C}_2\text{O}_4$	Saturated	N
Ammonium sulfate, $(\text{NH}_4)_2\text{SO}_4$	132	2 N
Ammonium sulfide, $(\text{NH}_4)_2\text{S}^*$	4 N
Ammonium polysulfide, $(\text{NH}_4)_2\text{S}_x$		
Ammonium tartrate, $(\text{NH}_4)_2\text{C}_4\text{H}_4\text{O}_6$	$\text{NH}_4\text{OH} + \text{H}_2\text{C}_4\text{H}_4\text{O}_6$	
Barium carbonate, BaCO_3	Solid diff. in H_2O	
Barium chloride, $\text{BaCl}_2 \cdot 2\text{H}_2\text{O}$	122	N
Barium hydroxide, $\text{Ba}(\text{OH})_2$	Saturated solution	$\frac{1}{3}$ N
Calcium chloride, CaCl_2 (free from SO_4)	56	N
Calcium hydroxide, $\text{Ca}(\text{OH})_2$	Saturated solution	$\frac{1}{2}$ N
Calcium sulfate, CaSO_4	Saturated solution	$\frac{1}{3}$ N
Cobalt nitrate, $\text{Co}(\text{NO}_3)_2 \cdot 6\text{H}_2\text{O}$	62.3	$\frac{1}{2}$ N
Ferric chloride, $\text{FeCl}_3 \cdot 6\text{H}_2\text{O}$	91.0	N
	(Add 5 cc. HCl)	
Ferric nitrate, $\text{Fe}(\text{NO}_3)_3 \cdot 9\text{H}_2\text{O}$	135	
Ferrous sulfate, $\text{FeSO}_4 \cdot 7\text{H}_2\text{O}^*$	139	
	(Add 20 cc. $\text{H}_2\text{SO}_4 + 50$ gm. $(\text{NH}_4)_2\text{SO}_4$)	
Lead acetate, $\text{Pb}(\text{C}_2\text{H}_3\text{O}_2)_2 \cdot 3\text{H}_2\text{O}$	186	N
	(Add $\text{HC}_2\text{H}_3\text{O}_2$ till acid)	
Magnesia mixture *	N
Mercuric chloride, HgCl_2	Saturated solution	$\frac{1}{2}$ N
Nickel nitrate, $\text{Ni}(\text{NO}_3)_2$	(See test solutions)	
Platinic chloride, H_2PtCl_6	10.66	$\frac{1}{10}$ N Pt
Potassium bromide, KBr	59.6	$\frac{1}{2}$ N
Potassium chromate, K_2CrO_4	292	3 N

* See "Preparation of Special Reagents."

Salt Solutions—Continued

	Grams per Liter	Approximate Normality
Potassium cyanide, KCN.....	65.2	N
Potassium dichromate, $K_2Cr_2O_7$	73.8	N
Potassium ferricyanide, $K_3Fe(CN)_6$	11.0	$\frac{1}{10}$ N
Potassium ferrocyanide, $K_4Fe(CN)_6 \cdot 3H_2O$	10.6	$\frac{1}{10}$ N
Potassium iodide, KI.....	83.1	$\frac{1}{2}$ N
Potassium nitrite, KNO_2	Saturated solution	24 N
Potassium permanganate, $KMnO_4$	32.0	N
Potassium sulfate, K_2SO_4	Saturated Solution	N
Potassium thiocyanate, KSCN.....	100.0	N
Silver nitrate, $AgNO_3$	42.5	$\frac{1}{4}$ N
Silver sulfate, Ag_2SO_4	Saturated solution	$\frac{1}{25}$ N
Sodium acetate, $NaC_2H_3O_2 \cdot 3H_2O$	410.0	4 N
Sodium carbonate, Na_2CO_3	160.0	
Sodium chloride, NaCl.....	29.3	$\frac{1}{2}$ N
Sodium cobalt nitrite, $Co(NO_2)_2 \cdot 3 NaNO_2^*$		
Sodium nitrite, $NaNO_2$	200.0	
Sodium phosphate, $Na_2HPO_4 \cdot 12H_2O$..	119.0	N
Sodium sulfate, $Na_2SO_4 \cdot 10H_2O$	160.0	
Sodium sulfite, $Na_2SO_3 \cdot 7H_2O$	125.0	
Stannous chloride, $SnCl_2$ conc. and dil*.		
Zinc sulfate, $ZnSO_4 \cdot 7H_2O$	140.0	

* See "Preparation of Special Reagents."

Other Solutions.—Amyl alcohol, $C_5H_{11}OH$, 95 and 99 per cent bromine water, Br; chlorine water, Cl; carbon disulfide, CS_2 , carbon tetrachloride; ethyl alcohol, C_2H_5OH ; indigo, $2(C_8H_5ON)$; hydrogen peroxide, H_2O_2 , 3 per cent; methyl alcohol, CH_3OH , acetone free.

Solid Reagents

Aluminum foil or filings.
 Ammonium nitrate, NH_4NO_3 .
 Ammonium sulfite, $(\text{NH}_4)_2\text{SO}_3 \cdot \text{H}_2\text{O}$.
 Antimony powder.
 Barium hydroxide, $\text{Ba}(\text{OH})_2 \cdot 8\text{H}_2\text{O}$.
 Bismuth dioxide, BiO_2 , (or sodium bismuthate).
 Borax, $\text{Na}_2\text{B}_4\text{O}_7 \cdot 10\text{H}_2\text{O}$.
 Calcium carbonate CaCO_3 (marble).
 Copper foil, Cu.
 Cotton, absorbent.
 Ferrous sulfate, $\text{FeSO}_4 \cdot 7\text{H}_2\text{O}$.
 Glass wool.
 Iron filings, nails, or wire or powder.
 Lead acetate, $\text{Pb}(\text{C}_2\text{H}_3\text{O}_2)_2 \cdot 3\text{H}_2\text{O}$.
 Lead dioxide, PbO_2 .
 Oxalic acid, $\text{H}_2\text{C}_2\text{O}_4 \cdot 2\text{H}_2\text{O}$.
 Potassium carbonate, K_2CO_3 .
 Potassium chloride, KCl.
 Potassium chlorate, KClO_3 .
 Potassium cyanide, KCN.
 Silica powder, SiO_2 .
 Silver nitrate, AgNO_3 .
 Sodium ammonium phosphate, $\text{NaNH}_4\text{HPO}_4 \cdot 4\text{H}_2\text{O}$.
 Sodium carbonate, Na_2CO_3 .
 Sodium and potassium nitrate, $\text{Na}_2\text{CO}_3 + \text{KNO}_3$.
 Sodium hydroxide, NaOH.
 Sodium nitrate, NaNO_3 .
 Sodium peroxide, Na_2O_2 .
 Sodium sulfite, $\text{Na}_2\text{SO}_3 \cdot 7\text{H}_2\text{O}$.
 Tartaric acid, $\text{H}_2\text{C}_4\text{H}_4\text{O}_6$.
 Tin foil, and granulated tin.
 Turmeric powder.
 Zinc, granulated.

Preparation of Special Reagents

Ammonium acetate may be prepared by neutralizing 100 cc. acetic acid with NH_4OH (about 96 cc.).

Ammonium Carbonate.—Dissolve in 80 cc. NH_4OH (0.90) + 500 cc. H_2O , and dilute to one liter.

Ammonium Molybdate.—90 g. of the salt in 100 cc. H_2O , 125 cc. 4N NH_4OH , 250 g. NH_4NO_3 .

Ammonium Sulfide.—Saturate 150 cc. strong NH_4OH with H_2S , add 150 cc. NH_4OH , and dilute to one liter.

Ammonium Polysulfide.—Add to a portion of the above a little free sulfur.

Aurin tricarboxylic acid (aluminon). See page 76.

Bromine Water.—To 50 g. KBr dissolved in 500 cc. H_2O , add 10 cc. Br. Shake until dissolved.

Chlorine Water.—Saturate water with Cl gas. Keep in dark bottle.

Cleaning Mixture.—Dissolve 50 g. of powdered $K_2Cr_2O_7$ in about 200 cc. of warm water; cool. Pour into cool solution with constant stirring about 250 cc. H_2SO_4 (conc.).

Dimethylglyoxime.—10 g. of the solid is dissolved in 1000 cc. of alcohol, 95 per cent C_2H_5OH .

Ferrous Sulfate.—Oxidation may be prevented by adding iron wire or nails to solution.

Hydrogen peroxide, 3 per cent sol.

Indigo Solution.—Dissolve in fuming H_2SO_4 , keeping cold, 1 part indigo, powdered, to 5 parts acid. Allow to stand several days, then pour into 20 parts of water.

Magnesium Ammonium Nitrate.—130 g. $Mg(NO_3)_2 \cdot 6H_2O$; 240 g. NH_4NO_3 in H_2O and add 17 cc. strong NH_4OH dilute to 1000 cc.

Manganous Chloride.—Saturated solution.

Magnesia Mixture.—50 g. $MgSO_4$ and 75 g. NH_4Cl dissolved separately in water; mix and add 300 cc. strong NH_4OH . Dilute to one liter.

Nessler's Reagent.—Dissolve 20 g. of KI in 50 cc. of water; add 32 g. HgI_2 . Dilute to 200 cc., and add 134 g. of KOH that has been dissolved in 260 cc. of water.

Phenolsulphonic Acid.—Dissolve about 24 g. phenol in 150 cc. H_2SO_4 conc., add 15 cc. of water. Keep in dark glass bottle.

Potassium Antimonate.—20 g. of H_2SbO_4 , 1000 cc. boiling water, boil till almost dissolved, cool and add 50 cc. of 5N KOH sol. Allow to stand 10 hours or more and filter.

Sodium Cobaltic Nitrite.—Dissolve 200 g. $NaNO_2$ in 400 cc. H_2O ; add 150 cc. of dilute (1.1) acetic acid and then 26 g. $Co(NO)_2 \cdot 6H_2O$. Allow to stand several hours and filter and dilute 100. Solution will decompose.

Stannous Chloride.—Dissolve 117 g. of $SnCl_2$ in 500 cc. HCl ; dilute to one liter. Place some fragments of metallic tin in the bottle containing the solution.

Starch paste may be preserved by addition of a few drops of chloroform.

Turmeric Sol.—Make alcoholic sol. using 95 per cent C_2H_5OH .

Sodium Stannite.—To 2 cc. stannous chloride solution ($SnCl_2$) add $NaOH$ solution, drop by drop, shaking the solution, until this clears.

TEST SOLUTIONS

Element	Formula	Grams per Liter
Aluminum.....	$\text{Al}(\text{NO}_3)_3 \cdot 9\text{H}_2\text{O}$	140.0
Antimony(ous).....	SbCl_3	19.0 _a
Antimony(ic).....	SbCl_5	24.7
Arsenic(ous).....	As_2O_3	13.0 _b
Arsenic(ic).....	As_2O_5	15.0
Barium.....	$\text{BaCl}_2 \cdot 2\text{H}_2\text{O}$	18.0
Bismuth.....	$\text{Bi}(\text{NO}_3)_3 \cdot 5\text{H}_2\text{O}$	23.0 _c
Borate $\text{B}(\text{O})_2$	$\text{Na}_2\text{B}_4\text{O}_7 \cdot 10\text{H}_2\text{O}$	9.0
Bromine.....	KBr	15.0
Cadmium.....	$\text{Cd}(\text{NO}_3)_2 \cdot 4\text{H}_2\text{O}$	27.5
Calcium.....	$\text{Ca}(\text{NO}_3)_2 \cdot 4\text{H}_2\text{O}$	59.0
Carbon CO_2	CaCO_3	17.0
Chlorine.....	NaCl	16.5
Chromium.....	$\text{Cr}(\text{NO}_3)_3$	46.0
Chromate CrO_4	K_2CrO_4	17.0
Cobalt.....	$\text{Co}(\text{NO}_3)_2 \cdot 6\text{H}_2\text{O}$	50.0
Copper.....	$\text{Cu}(\text{NO}_3)_2 \cdot 3\text{H}_2\text{O}$	38.0
Cyanide CN	NaCN	19.0
Fluorine.....	KF	30.5
Iodine.....	KI	13.0
Iron(ous).....	FeCl_2	23.0 _d
Iron(ic).....	$\text{Fe}(\text{NO}_3)_3 \cdot 9\text{H}_2\text{O}$	71.5
Lead.....	$\text{Pb}(\text{NO}_3)_2$	16.0
Magnesium.....	$\text{Mg}(\text{NO}_3)_2 \cdot 6\text{H}_2\text{O}$	106.0

See notes, next page, for *a*, *b*, *c*, *d*, *e*, and *f*.

Stock Solutions.— $\text{As}(\text{NO}_3)_3$, AsCl_3 , HgNO_3 , $\text{Mg}(\text{NO}_3)_2$, Na_2S , KClO_3 , Na_2HPO_4 , are prepared by dissolving five times the amounts of the salts as is stated in the table above. A dilution of 1 : 4, i.e., 200 cc. diluted to 1000 cc. will give the test solution. Stock solutions of the remainder of the salts are prepared by dissolving ten times the above amounts per liter of solution. Test solutions are prepared from these by diluting 1 : 9, i.e., 100 cc. to 1000 cc.

TEST SOLUTIONS—Continued

Element	Formula	Grams per Liter
Manganese	$\text{Mn}(\text{NO}_3)_2 \cdot 6\text{H}_2\text{O}$	53.0
Mercury(ic)	HgCl_2	13.5
Mercury(ous)	$\text{Hg}_2(\text{NO}_3)_2 \cdot 2\text{H}_2\text{O}$	14.0 <i>e</i>
Nickel	$\text{Ni}(\text{NO}_3)_2 \cdot 6\text{H}_2\text{O}$	50.0
Nitrate NO_3	NaNO_3	14.0
Nitrite NO_2	NaNO_2	15.0
Phosphorus PO_4	$\text{Na}_2\text{HPO}_4 \cdot 12\text{H}_2\text{O}$	38.0
Phosphorus	$\text{Ca}_3(\text{PO}_4)_2$	16.0 <i>c</i>
Potassium	KNO_3	26.0
Silicon	SiO_2	21.5
Silver	AgNO_3	16.0
Sodium	NaNO_3	37.0
Strontium	$\text{Sr}(\text{NO}_3)_2$	24.0
Tin(ous)	$\text{SnCl}_2 \cdot 2\text{H}_2\text{O}$	19.0 <i>b</i>
Tin(ic)	$\text{SnCl}_4 \cdot 3\text{H}_2\text{O}$	27.0 <i>f</i>
Zinc	$\text{Zn}(\text{NO}_3)_2$	29.0
Chlorate ClO_3	NaClO_3	13.0
Ferrocyanide $\text{Fe}(\text{CN})_6^{\text{IV}}$	$\text{K}_4\text{Fe}(\text{CN})_6 \cdot 3\text{H}_2\text{O}$	21.0
Ferricyanide $\text{Fe}(\text{CN})_6^{\text{III}}$	$\text{K}_3\text{Fe}(\text{CN})_6$	15.5
Sulfate SO_4	$\text{Na}_2\text{SO}_4 \cdot 10\text{H}_2\text{O}$	34.0
Sulfite SO_3	$\text{Na}_2\text{SO}_3 \cdot 7\text{H}_2\text{O}$	31.5
Sulfide S	$\text{Na}_2\text{S} \cdot 9\text{H}_2\text{O}$	75.0
Oxalate C_2O_4	$\text{K}_2\text{C}_2\text{O}_4 \cdot \text{H}_2\text{O}$	21.0
Thiocyanate SCN	K^+SCN	17.0

NOTES

- a. Dissolve in 8N HCl and dilute to 1000 cc. with 2N HCl.
- b. Digest in 50–60 cc. of 13N HCl and dilute to 1000 cc. with water.
- c. Dissolve in 2N HNO_3 .
- d. Dissolve in 0.5N HCl and add bright iron nails.
- e. Dissolve in 0.5N HNO_3 .
- f. Dissolve in 5N HCl.

APPENDIX

QUALITATIVE TESTS OF SUBSTANCES

BLOWPIPE AND FLAME TESTS OF SOLIDS

Blowpipe Tests on Charcoal

Heat a small portion of the material on charcoal in the reducing flame, using a blowpipe. Scoop out a round hole in the charcoal, place a little of the substance in the cavity, and direct the inner flame of the blowpipe against it at an angle of thirty degrees.

RESULT OF TEST	INFERENCE
Melts and runs into the charcoal.	Alkalies, K, Na, etc. Ca, Sr, Ba, Mg.
An alkaline residue on charcoal.	
A residue which, when moistened with a drop of $\text{Co}(\text{NO}_3)_2$ and heated in O. F., produces a color which is blue.	Aluminum, silicon. Zinc, tin, antimony. Barium.
Produces a color which is green.	
Produces a color which is red.	
Produces a color which is pink or rose-red.	Manganese.
Deflagrates.	Nitrates, chlorates.
Leaves an incrustation which is white near flame.	Antimony.
White, garlic odor.	Arsenic.
Dark red.	Silver.
Red to orange.	Cadmium.
Lemon yellow (hot), light yellow (cold).	Lead.
Orange yellow (hot), light yellow (cold).	Bismuth.
Yellow (hot), white (cold).	Zinc or tin, latter nonvolatile.

Blowpipe Tests.—Substance fused with Na_2CO_3 on Charcoal. Place a small amount of the substance on charcoal with a little sodium carbonate, and fuse, using reducing flame.

RESULT OF TEST	INFERENCE
Metallic globules, without incrustation.	Gold. Copper. Silver.
Yellow flakes.	
Red flakes.	
White globule, moderately soft.	Lead or tin (volatilized lead leaves yellow coat). Bismuth or antimony (yellowish).
Metallic globules, with incrustation.	
White, moderately soft beads.	Chromium.
White, brittle beads.	Manganese.
Yellow in O. F.	Sulfur compounds.
Green in O. F.	
A substance (in R. F.) which, when moistened and placed on a silver coin, leaves a brown or black stain.	

TEST	INFERENCE
Dark gray magnetic powder which, when moistened on a filter paper with a drop of dil. HCl and HNO ₃ , and gently dried over a flame, leaves a stain which is faint pink, turning blue. Green stain, turning yellow. A stain turned blue by K ₄ Fe(CN) ₆ .	Cobalt. Nickel. Iron.

In place of using charcoal the above tests may be made with a splinter of wood covered with a coating of fused Na₂CO₃. The test is made by dipping the heated splinter into a mixture of the powdered substance with fused sodium carbonate and plunging for a moment in the reducing flame. Examine the material on the splinter, scrape off on a piece of glazed paper and examine.

Blowpipe Test.—Substance moistened with cobalt nitrate solution and ignited.

COLOR OF RESIDUE OR INCRUSTATION	INFERENCE
Brick red.	BaO
Pink.	MgO.
Gray.	SrO, CaO.
Yellowish green.	ZnO.
Dark muddy green.	Sb ₂ O ₅
Bluish green.	SnO.
Blue.	Al ₂ O ₃ , SiO ₂ .

Flame Test

Flame Test.—Moisten a platinum wire in conc. HCl, dip into the powdered substance and insert into a Bunsen flame. If sodium is prominent, examine through a blue glass. (Test the cobalt glass to see if it is effective in cutting out the yellow sodium light by examining a sodium flame through it.)

FLAME COLOR	COLOR THROUGH BLUE GLASS	ELEMENT
Carmine red	Purple	Lithium
Dull red	Olive green	Calcium
Crimson	Purple	Strontium
Golden yellow	Absorbed	Sodium
Greenish yellow	Bluish green	Barium, molybdenum
Green		Cu, -PO ₄ , -B ₂ O ₃
Blue		Cu, Bi, Pb, Cd, Zn, Sb, As
Violet	Violet red	Potassium

The platinum wire should be cleaned before making the test. This can be accomplished by dipping it into conc. HCl and holding it in the Bunsen, or, better, a flame of a blast lamp, until the flame is no longer colored. Repeatedly dipping into the HCl may be necessary.

Examine the flame through a spectroscope, if available, and compare the spectra with a spectra chart. Mere traces of the alkali and alkaline earth metals can be detected in this way by their characteristic spectral lines.

IDENTIFICATION OF SUBSTANCES BY THEIR CRYSTAL FORM *

The systems with their axes and some typical crystal forms are shown below:

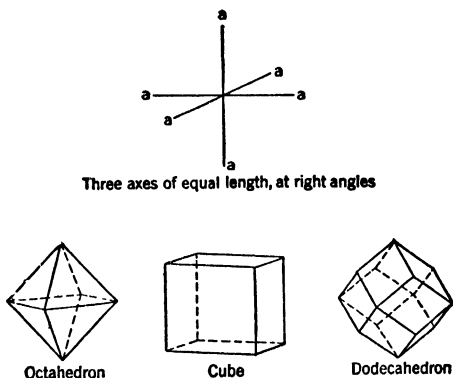

Fig. 10.—Regular or Isometric System.

I. Regular or Isometric System (Fig. 10).—Three axes of equal lengths intersecting at right angles.

Some common substances crystallizing in this system are: Potassium Iodide, KI; Barium Nitrate, $\text{Ba}(\text{NO}_3)_2$; Lead Nitrate, $\text{Pb}(\text{NO}_3)_2$.

II. Tetragonal System (Fig. 11).—Two axes of equal lengths and the third axis either longer or shorter, all intersecting at right angles.

Examples: Nickel Sulphate (hexahydrate), $\text{NiSO}_4 \cdot 6\text{H}_2\text{O}$; Urea, $\text{CO}(\text{NH}_2)_2$.

III. Hexagonal System (Fig. 12).—Three equal axes in the same plane intersecting at angles of 60° and a fourth axis longer or shorter perpendicular to the other three.

* General Chemistry, McCutcheon and Harry Seltz, D. Van Nostrand Co., Inc.

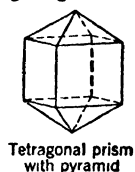
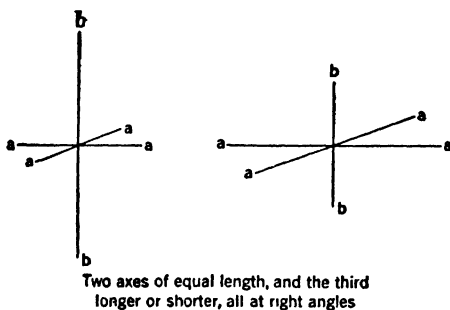
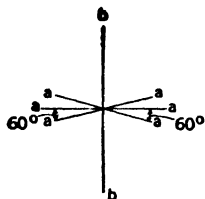
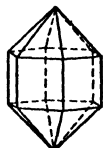
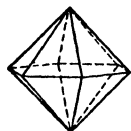

FIG. 11.—Tetragonal System.



Three axes in the same plane at angles of 60° , and a fourth axis longer or shorter, perpendicular to the plane of the other three



Hexagonal pyramid
Hexagonal pyramid with prism

FIG. 12.—Hexagonal System.

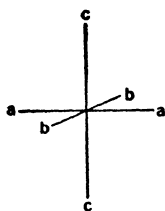

Three axes of unequal length, at right angles

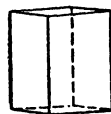
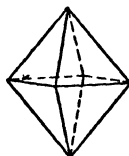

Rhombic pyramid
Rhombic prism

FIG. 13.—Rhombic System.

Examples: Lead Iodide, PbI_2 ; Cadmium Iodide, CdI_2 ; Sodium Nitrate, $NaNO_3$; Calcium Chloride (hexahydrate), $CaCl_2 \cdot 6H_2O$.

IV. Rhombic System (Fig. 13).—Three axes of unequal length at right angles to each other.

Examples: Sulphates of Zinc and Magnesium (heptahydrates), $ZnSO_4 \cdot 7H_2O$ and $MgSO_4 \cdot 7H_2O$; Potassium Sulphate, K_2SO_4 ; Potassium Nitrate, KNO_3 .

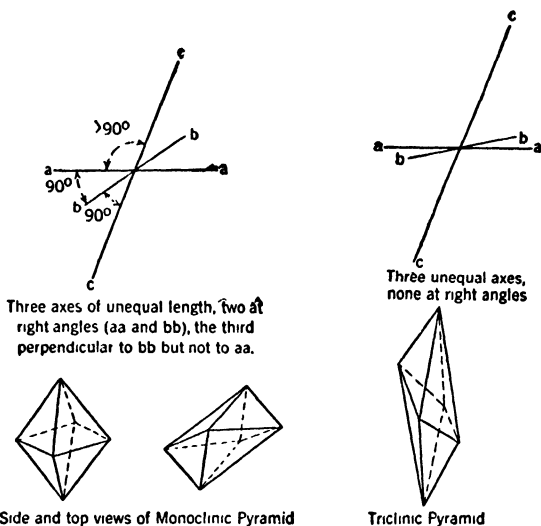

FIG. 14.—Monoclinic System. FIG. 15.—Triclinic System,

V. Monoclinic System (Fig. 14).—Three axes of unequal length, two at right angles, the third perpendicular to one of these but not to the other.

Examples: Magnesium Ammonium Sulphate, $(NH_4)_2SO_4 \cdot MgSO_4 \cdot 6H_2O$; Potassium Chlorate, $KClO_3$; Oxalic Acid, $H_2C_2O_4 \cdot 2H_2O$.

VI. Triclinic System (Fig. 15).—Three axes of unequal length, no two intersecting at right angles.

Examples: Manganous Sulphate, MnSO_4 ; Copper Sulphate (pentahydrate), $\text{CuSO}_4 \cdot 5\text{H}_2\text{O}$; Boric Acid, H_3BO_3 .

Isomorphism.—It frequently happens that two different elements in salts of corresponding type crystallize with the same number of molecules of water and are nearly identical in crystal form. Zinc, magnesium, and nickel, for example, form sulphates which crystallize from solution with 7 molecules of water— $\text{ZnSO}_4 \cdot 7\text{H}_2\text{O}$, $\text{MgSO}_4 \cdot 7\text{H}_2\text{O}$, $\text{NiSO}_4 \cdot 7\text{H}_2\text{O}$. These three salts crystallize in almost identical rhombic prisms. Such substances are said to be isomorphous. If a crystal of $\text{MgSO}_4 \cdot 7\text{H}_2\text{O}$ is suspended in a solution of zinc sulphate, upon slow evaporation $\text{ZnSO}_4 \cdot 7\text{H}_2\text{O}$ will crystallize upon it, following the form of the original crystal. If two such substances are present in a solution, the crystals which separate are mixtures of the two and are called isomorphous mixtures.

INDEX

Black-faced figures indicate principal determination.

Acetate, detection of.....	115
Acid test for carbonate.....	107
Acidity, testing of.....	5
Acids, chapter on.....	105
action on sulfides.....	112
detection table, general summary.....	141
notes on analysis of.....	121
preparation of solutions for analysis.....	132
reagents, preparation of.....	143
tests, suggestions.....	137
volatile, tests for.....	129
test for sulfite.....	109
Adsorbing substances.....	2
Alcohol-flame test for acetate.....	115
test for borate.....	109
Alkalies.....	10, 89
Alkaline earth group.....	10, 79
reagents, preparation of.....	143
Alkalinity, testing of.....	6
Alloys, decomposition of.....	131
Aluminum, detection of.....	59
summary of.....	72
Aluminon test for aluminum.....	59, 72
Ammonia, detection of.....	94, 129
test for copper.....	28, 36
Ammonium-carbonate group.....	10, 79, 134
molybdate test for phosphate.....	108
polysulfide, action of.....	30
principles, chemical of.....	66
Ammonium-sulfide group.....	9, 54, 133
action of NaOH on.....	57
tests for mercury.....	16

Analysis, systematic	127
tables, chloride acid group	119
tables, sulfate acid group	107
tables of separations. <i>See</i> titles of groups	
Antimony, detection of	33, 37
separation from copper sub-group	30, 32, 37
summary	49
Apparatus	1
cleaning of	6
detection of CO ₂ and H ₂ S (Fig. 9)	136
filtration (Fig. 2)	3
filtering by suction (Fig. 3)	4
saturating under pressure with H ₂ S (Fig. 1)	3
Arsenic, detection of	32, 37
separation from copper sub-group	30, 37, 39
summary	47
Arsenite and arsenate, detection of	140
Aurin-tricarboxylic test for aluminum	72
Barium, detection of	80
calcium, strontium, separation of	79
chloride test for borate	109
chloride test for carbonate	107
chloride test for fluoride	108
chloride test for phosphate	108
reagent group	107, 137
summary of	85
Bismuth, detection of	27, 28, 36
separation from members of the H ₂ S group	24, 27, 28, 36, 38
summary of	43
Blowpipe tests	151
Borate, detection of	109, 140
Borax bead test for cobalt	69
test for nickel	70
Bromide, detection of	111, 139
Cadmium, detection of	28, 29, 36
separation from H ₂ S group	26, 28, 29, 36, 38
summary of	45
Calcium, detection of	55, 80

Calcium, chloride test for fluoride	109
chloride test for oxalate	109
strontium and barium, separation of	79
summary of	87
Carbonate, detection of	107
and sulfide, detection of in mixture	136
residue	131
Chart A	13
I	19
II, A	38
II, B	39
III	64
IV	84
V	93
VI	97
VII	99
VIII	100
IX, A	101
IX, B	102
X	103
Chemical principles—HCl group or silver group	20
H ₂ S group, copper division	40
tin division	46
(NH ₄) ₂ S group, aluminum division	72
iron division	66, 71
(NH ₄) ₂ CO ₃ group	85
soluble basic group	94
testing of acids	121
Chlorate, detection of	115
Chloride, acid group	111
bromide, iodide, sulfocyanate detection in mixture	119
detection of	111, 139
test for silver	16
Chlorine oxidation test for bromide	111
Chromate, detection of	108, 138
oxidation test for iodide	112
test for lead	16, 28
Chromium, detection of by lead acetate	59
detection of by peroxide ether	59
summary of	73

Classroom reviews—HCl or silver group.....	24
H ₂ S group.....	51
(NH ₄) ₂ S group.....	76
(NH ₄) ₂ CO ₃ group.....	88
soluble basic group.....	96
the acids.....	123
Cloudy filtrates, prevention of.....	5
Cobalt, and nickel, action of ammonia on.....	57
detection of by potassium nitrite.....	57, 62
detection by of nitroso-β-naphthol.....	59
summary of.....	69
Cone-Cady on detection of zinc.....	75
Confirmatory tests—Ag, Hg, Pb.....	16
Bi, Cd, Cu, Hg, Pb.....	28
As, Sb, Sn.....	32
Al, Co, Cr, Fe, Mn, Ni, Zn.....	58
Ba, Ca, Sr.....	80
K, Mg, Na.....	89
Copper, and tin sub-groups.....	9, 26
detection of.....	28, 29, 36, 38
division of H ₂ S group.....	26
separation from group.....	26, 29, 36, 38
summary.....	44
Crystals, identification of.....	153
Cyanide, detection of.....	113
Decantation, washing by.....	5
Decomposition flask (Fig. 8).....	128
Decomposition and solution of solids.....	129
Diphenyl-carbide test for chromates.....	65, 74
Diphenylamine-ferricyanide test for zinc.....	75
Diphenylamine test for nitrate.....	114
Dipotassium-dihydrogen-proantimonate reagent.....	94
test for sodium.....	90, 91
Distinguishing tests—antimony from arsenic.....	34
Etching test for fluoride.....	109
Ethyl alcohol separation of CaCrO ₄ from SrCrO ₄	86
Ferric chloride test for thiocyanate.....	113
nitrate test for iodide.....	112

Ferric, salt test for ferricyanide.....	112
salt test for ferrocyanide.....	112
Ferricyanide, detection of.....	112
Ferrocyanide, detection of.....	112
Ferrocyanide test for iron.....	58
Ferrous salt test for ferricyanide.....	112
sulfate test for nitrate.....	114
Flame test, for barium.....	80
calcium.....	81
potassium.....	90, 92
sodium.....	90, 92
strontium.....	80
test of substances, method for.....	87
tests for substances.....	152
Fluoride, detection of.....	108, 138
Fusion method for insoluble residues.....	130
Gelatinous precipitates.....	5
Group separations, study of.....	11
outline table.....	12
outline chart.....	13
tables and charts. <i>See</i> titles of groups.	
Hydrogen-chloride group.....	9, 14, 133
sulfide group.....	9, 26, 133
Hypobromite or hypochlorite tests for antimony.....	33, 37
Incompatibilities, acids.....	136
Insoluble residue, decomposition of.....	130
Interfering substances for $(\text{NH}_4)_2\text{S}$ group.....	54
Introduction.....	1
Iodide, detection of.....	112, 139
Iron, and aluminum divisions, separations.....	9, 54, 55
detection of by ferrocyanide.....	58, 62
thiocyanate.....	58, 62
division of $(\text{NH}_4)_2\text{S}$ group, separations.....	57
summary of.....	72
Lead, acetate test for chromate.....	59, 74
detection of.....	14, 16, 18, 19

Lead, separation from Ag and Hg.....	14, 18, 19
separations from H ₂ S group.....	26, 27, 35, 38
summary of.....	20, 42
Less common elements, grouping of.....	10
Lime water test for carbonate.....	107
Manganese, detection of by bismuthate.....	58
summary of.....	71
Magnesium, ammonium nitrate test for arsenic.....	32
and the alkalis.....	10, 89
detection of.....	88, 91
summary of.....	94
Mercuric chloride test for tin.....	33, 37
Mercury, detection of.....	14, 16, 18, 19, 26, 28, 35, 38
separation from Ag and Pb.....	14, 18, 19
H ₂ S group.....	26, 35, 38
summary of.....	22, 42
Metallic substances, decomposition of.....	131
Metals, group list.....	9
Minerals, solution of.....	132
Nickel, and cobalt, action of ammonia on.....	57
detection of by dimethylglyoxime.....	59, 62
summary of.....	70
Nitrate (acid) analysis of.....	120
and nitrite, detection of.....	140
detection of.....	114
group.....	106, 114
Nitrite, detection of.....	114
Nitroso-beta-naphthol test for cobalt.....	59
Non-metallic solids decomposition of (organic matter present).....	129
(organic matter absent).....	130
Organic matter, test for.....	129
Oxalate, detection of.....	109, 138
test for calcium.....	87
Perchlorate test for potassium.....	88
Permanganate, detection of.....	115
oxidation test for bromide.....	111
Peroxide-ether test for chromium.....	59

Phosphate, detection of	55, 108
effect of	54
Phosphate, removal of ion	55
test for magnesium	88
Potassium, cobaltic nitrite	57
cyanide, action on nickel	70
detection of	88, 92, 94
dihydrogen antimonate test for sodium	90, 92
ferrocyanide test for copper	29, 36
nitrite action on cobalt	57, 69
summary of	94
Precipitates, washing of	4
Precipitation	2
Preliminary tests of acids—sulfate group	107
chloride group	111
nitrate group	114
bases—HCl or silver group	14
H ₂ S copper division	26
H ₂ S tin division	30
(NH ₄) ₂ S iron division	54, 57
aluminum division	58
(NH ₄) ₂ CO ₃ , alkaline earth group	79
soluble basic group	89
tables, barium chloride group	117
silver nitrate group	117
soluble acid group	117
Preparation and solution of the sample—acid analysis	116
water solution, heavy metals absent	116
heavy metals present	116
Qualitative tests of substances, tables of	151
Reactions	24, 52, 77, 88, 96, 124
Reagent bottle (Fig. 5)	7
Reagents, preparation of	143
strength of	7
Reducing acids, detection of	138
Rules, washing of precipitates	4
Salts, reagents, preparation of	144
solution of	132

Separation of alkalis	91
Separation of alkaline earths	82
aluminum division of $(\text{NH}_4)_2\text{S}$ group	62
ammonium-sulfide group	61
hydrogen-chloride group	18, 19
iron division of $(\text{NH}_4)_2\text{S}$ group	62
silver group	18, 19
without the use of H_2S	98
Silver, detection of	14, 16, 18, 19
group	9, 14, 133
nitrate test for arsenic	33
bromide	111
chloride	111
cyanide	113
ferriocyanide	112
iodide	112
phosphate	108
sulfide	112
thiocyanate	113
reagent or chloride group	111, 137
separation from Pb, Hg	14, 18, 19
summary of	31
Sodium, cobaltinitrite reagent	94
cobaltinitrite test for potassium	88, 92, 94
detection of	92
stannite test for bismuth	28, 36
summary of	94
Solid reagents	146
Solubility, alkaline earth group, table of	81
tables of (Leech)	back cover
Soluble acid or nitrate group	106, 114, 137
basic group	10, 89, 134
Solution, preparation of	2
Special reagents, preparation of	146
Special tests—chromium trivalent and hexavalent	65
cobalt salts	65
ferrous and ferric salts	65
manganese salts	65
state of oxidation	65

Stannic and metastannic compounds.....	51
Stannous chloride test for mercury.....	16
Starch-iodide test for nitrite.....	115
Strontium, detection of.....	80
separation from barium and calcium.....	79
summary of.....	86
Sulfate (acid) group.....	107
detection of.....	138
test for barium.....	85
lead.....	16, 18, 27, 36
strontium.....	87
Sulfide, detection of.....	112
test for.....	119
Sulfides of $(\text{NII})_2\text{S}$ group, colors of.....	56
Sulfite, detection of.....	109, 138
Sulfuric acid test for acetate.....	115
chlorate.....	115
tartrate.....	110
Summary of analysis.....	133, 136
Systematic analysis of substances.....	127
Table I. HCl group.....	18
II, A. H_2S group, copper division.....	37
II, B. H_2S group, tin division.....	35, 36
III. $(\text{NH}_4)_2\text{S}$ group.....	61
IV. $(\text{NH}_4)_2\text{CO}_3$ group.....	82
V. Soluble basic group. <i>See also charts.</i>	91
acid separations. <i>See chapter on Acids.</i>	
solubility tables (Leech).....	back cover
Tartrate, detection of.....	110
Test solutions, preparation of.....	148
Tin, detection of.....	33, 37
distinction of stannic and stannous salts.....	34
division of H_2S group.....	30
separation from H_2S group.....	30, 32, 37
summary of.....	50
Thiocyanate-alcohol-ether test for cobalt.....	69

Thiocyanate, detection of.....	113, 139
test for iron.....	58
Thiourea test for nitrate.....	114
Turmeric paper test for borate.....	109
Wash bottle (Fig. 4).....	6
Zinc, detection of by H_2S	59, 62
separation from $(NH_4)_2S$ group elements.....	62
summary of.....	74

Some Van Nostrand Text and Reference Books on Chemistry

- General Chemistry; Theoretical and Descriptive.** By THOMAS P. MC CUTCHEON, PH.D., *Professor of Inorganic Chemistry, University of Pennsylvania*; HARRY SELTZ, PH.D., *Associate Professor of Physical Chemistry, Carnegie Institute of Technology*; and J. C. WARNER, PH.D., *Associate Professor of Electro-Chemistry, Carnegie Institute of Technology.* Second Edition. \$3.50
- An Introduction to Organic Chemistry.** By ROGER J. WILLIAMS, PH.D., *Associate Professor of Chemistry, University of Oregon.* Third Edition. \$3.50
- A Laboratory Manual of Organic Chemistry.** By PROFESSORS ROGER J. WILLIAMS and RAY Q. BREWSTER. Second Edition. \$2.00
- Elements of Chemistry.** By WILLIAM FOSTER, A.M., PH.D., *Russell Wellman Moore Professor of Chemistry, Princeton University.* Second Edition. \$3.00
- Inorganic Chemistry for Colleges.** By WILLIAM FOSTER. \$3.90
- A Laboratory Manual of Elementary Physical Chemistry.** By EDWARD MACK, JR., *Professor of Chemistry, University of North Carolina*; and WESLEY G. FRANCE, *Associate Professor of Colloid Chemistry, Ohio State University.* Second Edition. \$2.35
- Qualitative Chemical Analysis; A Laboratory Guide.** By WILFRED W. SCOTT, SC.D., *Professor of Analytical Chemistry, University of Southern California*; Editor, "Standard Methods of Chemical Analysis." Fifth Edition. \$3.00
- Elements of Qualitative Chemical Analysis.** By WILFRED W. SCOTT. \$1.60
- Standard Methods of Chemical Analysis.** Edited by WILFRED W. SCOTT. (IN COLLABORATION WITH RENOWNED SPECIALISTS.) Fourth Edition. Two Vols. (not sold separately). \$12.00
- Elements of Industrial Chemistry.** By ALLEN ROGERS, *Supervisor, Department of Chemistry, Pratt Institute, Brooklyn*; *Lecturer on Industrial Chemistry, Columbia University.* Second Edition. \$4.50
- A Manual of Industrial Chemistry.** Edited by ALLEN ROGERS. (IN COLLABORATION WITH EMINENT SPECIALISTS.) Fifth Edition. Two Vols. (not sold separately). \$13.00
- Unit Processes and Principles of Chemical Engineering.** By JOHN C. OLSEN, PH.D., D.S.C., *Professor of Chemical Engineering, Polytechnic Institute, Brooklyn, N. Y.*, Formerly, Sec. and Pres., Amer. Inst. Chem. Engrs. (IN COLLABORATION WITH EMINENT SPECIALISTS.) \$5.00
- Van Nostrand's Chemical Annual.** Rewritten Seventh Issue, 1934. Edited by JOHN C. OLSEN. Flexible Fabrikoid. \$5.00
- An Introductory Course in Physical Chemistry.** By WORTH HUFF RODEBUSH, PH.D., *Professor of Physical Chemistry, University of Illinois*; and ESTHER KITTREDGE RODEBUSH, M.A. \$3.75
- A Treatise on Physical Chemistry.** Edited by HUGH S. TAYLOR, D.S.C. (Liverpool), *Professor of Physical Chemistry, Princeton University.* A Cooperative Effort by a Group of Physical Chemists. Second Edition. Two Volumes (not sold separately). \$15.00
- Elementary Physical Chemistry.** By HUGH S. TAYLOR. \$3.75

Van Nostrand books sent on approval to residents of the United States and Canada. General Catalog sent free upon request.

