

UNIVERSAL  
LIBRARY

**OU\_164567**

UNIVERSAL  
LIBRARY





**OSMANIA UNIVERSITY LIBRARY**

Call No. 545.9/Or H 0 Accession No. 29856

Author

Title *Organic Synthesis. V. 1*

This book should be returned on or before the date last marked below.



# ORGANIC SYNTHESSES

## THESE VOLUMES NOW READY

---

### Volume I.

ROGER ADAMS, University of Illinois, Editor-in-Chief. vi + 84 pages, 6 by 9; 7 figures. Cloth, \$1.50 net.

### Volume II.

JAMES BRYANT CONANT, Harvard University, Editor-in-Chief. vii + 100 pages, 6 by 9; 3 figures. Cloth, \$1.50 net.

### Volume III.

HANS THACHER CLARKE, Eastman Kodak Company, Editor-in-Chief. v + 105 pages, 6 by 9; 3 figures. Cloth, \$1.50 net.

### Volume IV.

OLIVER KAMM, Parke, Davis, and Company, Editor-in-Chief. v + 89 pages, 6 by 9; 3 figures. Cloth, \$1.50 net.

### Volume V.

CARL SHIPP MARVEL, University of Illinois, Editor-in-Chief. v + 110 pages, 6 by 9; 3 figures. Cloth, \$1.50 net.

### Volume VI

HENRY GILMAN, Iowa State College, Editor-in-Chief. v + 120 pages; 6 by 9; 5 figures. Cloth. \$1.50 net.

# ORGANIC SYNTHESSES

AN ANNUAL PUBLICATION OF SATISFACTORY  
METHODS FOR THE PREPARATION  
OF ORGANIC CHEMICALS

## EDITORIAL BOARD

<b>ROGER ADAMS</b> , <i>Editor-in-Chief</i> University of Illinois Urbana, Illinois	<b>JAMES BRYANT CONANT</b> Harvard University Cambridge, Mass.
<b>HANS THACHER CLARKE</b> Eastman Kodak Co. Rochester, N. Y.	<b>OLIVER KAMM</b> Parke, Davis & Co. Detroit, Mich.

VOL. I.

NEW YORK  
JOHN WILEY & SONS,  
LONDON: CHAPMAN & HALL, LIMITE

Copyright, 1921  
BY  
ROGER ADAMS

Printed in U. S. A.

PRESS OF  
BRAUNWORTH & CO., INC.  
BOOK MANUFACTURERS  
BROOKLYN, NEW YORK

## INTRODUCTION TO THE SERIES

---

THE publication of this series of pamphlets has been undertaken to make available in a permanent form complete detailed directions for the preparation of various organic chemical reagents. In announcing this purpose it may be well to mention at the outset some of the difficulties in the way of the research chemist, which it is hoped this series will be able to overcome. The cost of chemicals is prohibitive to the majority of chemists; this was true before the war when Kahlbaum's complete supply was available, and to-day with our dependence on domestic stocks, this cost has increased. The delay in obtaining chemicals, especially from abroad, even if the expense need not be considered, is an important factor. These difficulties have therefore thrown the research chemist on his own resources. The preparation of materials for research, always time consuming and annoying, is made increasingly so by the inexactness of the published information which so often omits essential details. Because of this, much needless experimentation is necessary in order to obtain the results given in the published reports. As the additional information thus acquired is seldom published, duplication of such experiments occurs again and again,—a waste of time and material. It is hoped these difficulties may be remedied by the publication of this series of pamphlets. In other words, the authors hope to make this a clearing house for the exchange of information as to methods of preparation of some of the most needed organic chemical reagents.

On account of the impossibility of obtaining the less common organic chemicals in the United States during the past few years,

university laboratories have had no option but to prepare their own supplies. At the University of Illinois, for instance, a special study has been made of this field, and methods for the production of various substances have been investigated. As a result, reliable methods and directions have been developed for producing the materials in one-half to five pound lots. Such work as Illinois has done is now being given an even more extensive scope at the Research Laboratory of the Eastman Kodak Company. It is felt that the results from these various laboratories should be available to all chemists and it is hoped that they eventually will be completely incorporated in these pamphlets.

The organic chemicals herein discussed have been quite arbitrarily chosen, being those which have been needed in various research laboratories in the last years and for which the directions happen now to be ready for publication. The methods are in only a few cases new ones; they are in general the most satisfactory to be found in the literature. Only such details have been added as will enable a man with a reasonable amount of experience in organic chemistry to duplicate the results without difficulty. To be absolutely sure that each set of directions can be repeated, every experiment has been carried out in at least two laboratories. Only after exact duplication of the results in both laboratories are the directions considered ready for publication. The names of the chemists who have studied the various experiments are given so that further information concerning any obscure point can be obtained if any question arises in using these directions. And finally, in describing the experiments, special attention has been given to the explanation of why it is necessary to follow the directions carefully, and what will happen if these directions are not followed.

Although the main object in this series is to give the most convenient laboratory methods for preparing various substances in one-half to five pound lots, an attempt has also been made to have these processes as far as possible adaptable to large scale development. For example, extractions have been avoided wherever possible,<sup>7</sup> cheap solvents have been sub-

stituted for expensive ones, and mechanical agitation, a procedure extremely important in the success of many commercial processes, has usually been specified. The apparatus used is always carefully described and wherever necessary an illustration is given. Accompanying each preparation there will be found a bibliography containing references to all the methods for the production of the substance described in the literature up to January, 1921. This is given in order to aid any future investigator who may wish to study or to improve the methods of preparation. It is not claimed that the methods are, in every case, completely perfect, but only that the yields are very satisfactory and allow the production of the substances at a reasonable cost. It is hoped therefore that the pamphlets will benefit not only the scientific research man of the university, but also the technical chemist who desires to develop the preparation of one of these substances to a large scale process of manufacture. The editors trust also that this work may be used to advantage as a preparation manual in intermediate or advanced courses in organic chemistry in university laboratories, and that it will aid small colleges in the production of necessary reagents which they are often financially unable to purchase.

The pamphlets are to be edited by the following committee: Roger Adams, University of Illinois, Urbana, Illinois; J. B. Conant, Harvard University, Cambridge, Massachusetts; H. T. Clarke, Eastman Kodak Company, Rochester, New York; Oliver Kamm, Parke, Davis Company, Detroit, Michigan; each to act for one year as editor-in-chief and the other three to assist him as associate editors. A new number of the series will appear annually, and every five years the data will be rearranged, revised, corrected, and then published in book form. The number of preparations to be completed yearly is not fixed. There will be, it is certain, about twenty; and it is hoped, as the interest is stimulated in this work, that this number may increase considerably. The editors especially desire to solicit contributions from other chemists, not only in this country but abroad. Whenever a compound is thoroughly and extensively studied in connection with some research, it is hoped that

complete directions for its preparation will be assembled and sent to the editor. He will then have them checked and published in a subsequent number. Directions for the preparation of substances already on the market are needed to make this work complete and will be gladly accepted.

It will, of course, be recognized that an occasional mistake or omission will inevitably be found in such a pamphlet as this which contains so many references and formulæ. The committee on publication will therefore deem it a favor if they are notified when any such error is discovered. It is hoped also that if any chemist knows a better method for the preparation of any of the compounds considered, or if anyone discovers any improvements in the methods, he will furnish the authors with such information. Any points which may arise in regard to the various preparations will be gladly discussed. In conclusion, the editors are ready to do all they can to make this work successful, and welcome suggestions of any kind. They feel that the success of the series will undoubtedly depend upon the cooperation of others, and as its success promises to be important to research chemists, the editors urge all interested to assist.

THE EDITORS

## TABLE OF CONTENTS

---

	PAGE
I. ALKYL BROMIDES.....	1
Allyl Bromide.....	3
<i>iso</i> -Amyl Bromide.....	4
<i>n</i> -Butyl Bromide.....	5
Ethyl Bromide.....	6
Lauryl Bromide.....	7
<i>n</i> -Octyl Bromide.....	7
Trimethylene Bromide.....	8
II. ALLYL ALCOHOL.....	15
III. BENZENE SULFONYL CHLORIDE.....	21
IV. BENZIL.....	25
✓ V. BENZILIC ACID.....	29
✓ VI. BENZOIN.....	33
VII. $\alpha$ -BROMONAPHTHALENE.....	35
VIII. <i>p</i> -BROMOPHENOL.....	39
IX. DIACETONE ALCOHOL.....	45
X. FURFURAL.....	49
XI. MESITYL OXIDE.....	53
XII. METHYLENE IODIDE.....	57
XIII. METHYL HEXYL CARBINOL (CAPRYL ALCOHOL).....	61
XIV. OXALIC ACID (ANHYDROUS).....	67
XV. THIOPHENOL.....	71
XVI. TRIMETHYLAMINÉ.....	75
XVII. TRIMETHYLAMINE HYDROCHLORIDE.....	79
INDEX.....	83



# ORGANIC SYNTHESSES

## I

### ALKYL AND ALKYLENE BROMIDES

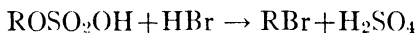
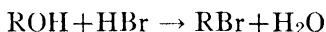

Prepared by OLIVER KAMM and C. S. MARVEL.

Checked by H. T. CLARKE and ANNE W. DAVIS.

#### 1. General Procedure

A GIVEN alcohol is treated with 25 per cent excess of aqueous (48 per cent) hydrobromic acid together with sulfuric acid. The mixture is refluxed in order to convert the alcohol as completely as possible into the corresponding bromide, and the latter is then removed from the reaction mixture by distillation. Slight variations from this procedure depend upon the physical and chemical properties of the alcohol used, or of the bromide formed in the reaction. For example, in the preparations of ethyl and allyl bromides, the reaction mixture is not refluxed because of the volatility of the former compound, and because of the chemical reactivity of the latter; in the preparation of *iso*-amyl bromide, too large a proportion of sulfuric acid may produce appreciable decomposition; while halides of high molecular weight, because of their low volatility, are separated from the reaction mixture mechanically, instead of by distillation.

The use of a modified sodium bromide-sulfuric acid method for the preparation of alkyl bromides is described in connection with the preparation of *n*-butyl bromide. This method has been used also for the preparations of *iso*-amyl and trimethylene bromides, but, in general, the yields were found to be somewhat lower than those obtained with the hydrobromic-sulfuric acid method.

### (A) HYDROBROMIC ACID

Hydrobromic acid may be prepared conveniently by the interaction of bromine and sulfur dioxide in the presence of water.<sup>1</sup>

In a 3-l. round-bottom flask are placed 1200 g. of bromine, 500 cc. of water, and 1500 g. of crushed ice. A fairly rapid stream of sulfur dioxide is allowed to pass from a pressure tank into the flask, the outlet of the gas-tube being placed below the surface of the bromine layer. The flow of sulfur dioxide is adjusted at such a rate that the gas is completely absorbed. About two hours will serve for the completion of the reduction, at which time the mixture will assume a yellow color which is not removed by further addition of sulfur dioxide, an excess of which is to be avoided. To prevent loss of gaseous hydrobromic acid, it is advisable to cool the mixture during the progress of the reduction. It is advisable also to agitate the mixture occasionally during the first stage of the reduction.

When the reduction is completed, the flask is connected with a condenser and the mixture subjected to distillation. The boiling point of constant boiling hydrobromic acid is 125–126° at 760 mm., but it must be remembered that in distilling the product from the sulfuric acid mixture, the thermometer reading should not be relied upon as an index to the composition of the distillate. Towards the end of the distillation the thermometer may rise to 130° and above, when water with only traces of acid distils from the sulfuric acid residue. Upon redistillation of the product the thermometer reading may be relied upon. For many uses a product free from traces of

<sup>1</sup> J. Chem. Soc. 77, 648 (1900). Pickles recommends preparing hydrobromic acid from potassium bromide and sulfuric acid in the presence of a little stannous salt to prevent the formation of traces of bromine. Chem. News, 119, 89 (1919).

sulfuric acid is not required and one distillation is sufficient. In such cases the progress of the distillation is followed by determinations of the specific gravity of the distillate.

According to the above procedure, 20 kg. of 48 per cent hydrobromic acid were prepared from 10.3 kg. of bromine. The actual time required by one man for the preparation of this quantity was twenty-three hours.

For the preparation of alkyl bromides on a relatively large scale the hydrobromic acid need not be distilled but may be used directly for the subsequent preparation. The fact that 0.5 mole of sulfuric acid is present for each mole of hydrobromic acid is not a disadvantage, since the presence of sulfuric acid is desired, and consequently a correspondingly smaller quantity need be added.

### (B) ALLYL BROMIDE

In a 3-l. round-bottom flask, a hydrobromic acid solution is made by the sulfur dioxide reduction of 480 g. of bromine in the presence of 510 g. of ice water or a mixture is made of 1000 g. of aqueous 48 per cent hydrobromic acid and 300 g. of concentrated sulfuric acid. To this are added 385 cc. of aqueous allyl alcohol, which, according to bromine titration, contain 233 g. of pure allyl alcohol. The 3-l. round-bottom flask is fitted with a mechanical stirrer (Fig. 1, p. 4, see also Notes), separatory funnel, and an efficient condenser set for downward distillation. Stirring is started and 300 g. of concentrated sulfuric acid are added gradually through the separatory funnel to the warm solution. The allyl bromide distils over completely in about one-half to one hour. The crude allyl bromide is washed with dilute sodium carbonate solution, is dried over calcium chloride and is distilled. The yield of product boiling at 69-72° from a number of experiments varies from 445 to 465 g. (92-96 per cent theory). A small high-boiling fraction is also obtained and examination has shown this to consist of propylene bromide.

(C) *iso*-AMYL BROMIDE

In a 5-l. round-bottom flask, a hydrobromic acid solution is prepared (details under (A) "Hydrobromic Acid") by passing sulfur dioxide into a mixture of 1100 g. of crushed ice and 1000 g. of bromine. This is equivalent to a mixture of 2100 g.

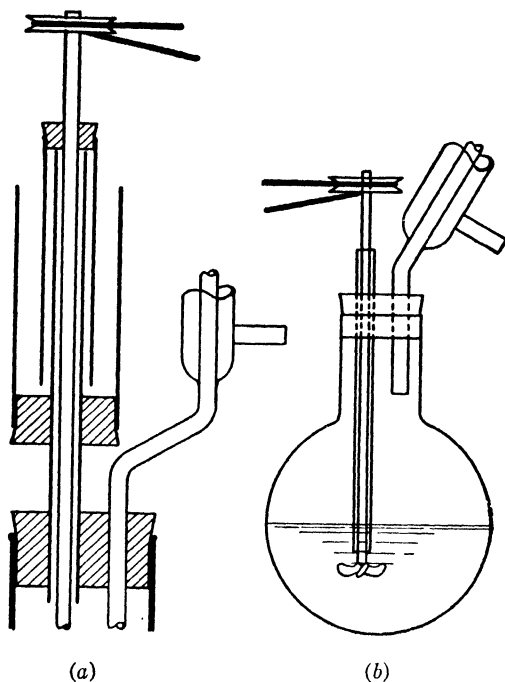

FIG. 1.

of 48 per cent hydrobromic acid and 600 g. of concentrated sulfuric acid. There are then added 880 g. of *iso*-amyl alcohol (b. p. 130–132°) and 100 g. of concentrated sulfuric acid in the order mentioned. The clear homogeneous solution is refluxed gently during a period of three hours. Even during the early stages of the heating, the separation of *iso*-amyl bromide is observed and the reaction appears to be complete after about

one hour. The product is isolated as in the preparation of *n*-butyl bromide.

A yield of 1435 g. of crude product is obtained. After purification with concentrated sulfuric acid the product weighs 1410 g. (93 per cent theory). Upon fractionation, however, it is found that appreciable amounts of high-boiling product are present and therefore the yield of fractionated material boiling over the range 116–120° varies in different experiments from 1330 to 1360 g. (88–90 per cent theory).

#### (D) *n*-BUTYL BROMIDE

*Hydrobromic-sulfuric Acid Method.* In a 5-l. round-bottom flask are placed 1300 g. of crushed ice and 1200 g. of bromine. The flask is cooled in an ice water bath and sulfur dioxide is passed into the mixture until the red color due to free bromine has just disappeared (details under (A) "Hydrobromic Acid"). This mixture is equivalent to 2500 g. of 48 per cent hydrobromic acid to which 750 g. of concentrated sulfuric acid have been added.

888 g. of *n*-butyl alcohol are added to the sulfuric-hydrobromic acid mixture. Following this, 600 g. of concentrated sulfuric acid are added in several portions, with shaking. The flask is then attached to a reflux condenser and the mixture is refluxed during a period of three hours, during which time the formation of butyl bromide is carried practically to completion. The flask is now fitted with a condenser set downward and the product removed from the reaction mixture by direct distillation (about one hour). The water-insoluble layer is separated, washed first with water, then with 200 g. of cold concentrated sulfuric acid, and finally with a sodium carbonate solution (50 g. of sodium carbonate in 500 cc. of water). The product is separated as completely as possible from the aqueous layer, dried during several hours with a small quantity (15 to 25 g.) of calcium chloride, and distilled. The yield of product boiling between 101–104° is 1560 g. (95 per cent theory).

*Sodium Bromide Method.* In a 5-l. round-bottom flask are placed 1350 cc. of water and then with stirring 1545 g. (15 moles) of finely powdered sodium bromide are added. It is advisable to add the salt to the water in this manner in place of the reverse procedure, in order to avoid caking of the sodium bromide. 888 g. (12 moles) of *n*-butyl alcohol and then gradually 2000 g. of concentrated sulfuric acid are added. The last half of the acid is added through a dropping funnel after the flask has been connected with a reflux condenser. The mixture is shaken occasionally during the addition of the sulfuric acid because of a tendency to separate into layers, and is finally refluxed during a period of four hours. The condenser is then set downward and the butyl bromide removed by distillation. The product is purified as in the preceding experiment, the yield of product boiling between 101–104° being 1480 g. (90 per cent theory).

#### (E) ETHYL BROMIDE

In the preparation of hydrobromic acid for the manufacture of ethyl bromide, particular care must be taken to avoid the presence of any excess of sulfur dioxide gas. The evolution of gas during the distillation of the ethyl bromide will invariably result in a large loss of this volatile product (b. p. 38–39°).

A hydrobromic acid solution is prepared in a 5-l. round-bottom flask by the reduction of 1000 g. of bromine in the presence of 1100 g. of cracked ice. Experimental details have been given under (A) "Hydrobromic Acid." A mixture of 2075 g. of aqueous (48 per cent) hydrobromic acid and 600 g. of concentrated sulfuric acid may be used in place of the above reduction mixture. After the addition of 500 g. of ordinary 92 per cent ethyl alcohol, the flask is attached to a long condenser set ready for distillation and 1000 g. of concentrated sulfuric acid are slowly added through a separatory funnel. Because of the volatility of ethyl bromide, the mixture is not heated under reflux, but is subjected instead to slow distillation. The end of the condenser is provided with an adapter tube, and the distillate is collected in a flask containing ice water. The crude

ethyl bromide, weighing 1055 g., is purified as directed under the butyl bromide experiment. The washing with concentrated sulfuric acid is almost superfluous unless a product of special purity is desired; for instance, in the present experiment a washing with 300 g. of concentrated acid results in a decrease in weight of only 10 g.

The product is washed and purified as in the butyl bromide preparation. It is distilled from a water bath and boils at 38.5–39.5°, provided chips of porous plate are added to prevent superheating. Final yields vary from 90–95 per cent of the theory according to the precautions taken to prevent losses due to evaporation.

#### (F) LAURYL BROMIDE

In a 250 cc. round-bottom flask are placed 70 g. of hydrobromic acid (48 per cent) and 22 g. of concentrated sulfuric acid. To this mixture are added 40 g. of lauryl alcohol (b. p. 188–192° at 110 mm.) and the mixture is then refluxed for five hours. The bromide is isolated as described in the preparation of octyl bromide. The product is distilled under reduced pressure and is collected from 175–180° at 45 mm. The yield is 49 g. (91 per cent theory).

#### (G) *n*-OCTYL BROMIDE

In a 500 cc. round-bottom flask are placed 240 g. of hydrobromic acid (48 per cent), 62 g. of concentrated sulfuric acid, and 71 g. of *n*-octyl alcohol (b. p. 135–140° at 100 mm.). The mixture is boiled under reflux for three and a half hours. The solution is diluted with water and the bromide layer is separated, washed once with a little cold concentrated sulfuric acid, then with water and finally with dilute sodium carbonate solution. The crude yield is 102 g.; this is dried over a little calcium chloride and distilled. The product is collected at 196–200° and amounts to 96 g. (91 per cent theory).

## (H) TRIMETHYLENE BROMIDE

In a 5-l. round-bottom flask are placed 1200 g. of bromine and 1300 g. of crushed ice. The bromine is reduced with sulfur dioxide as already directed under (A) "Hydrobromic Acid." In place of the above reduction mixture, there may be used a mixture of 2500 g. of aqueous 48 per cent hydrobromic acid and 750 g. of concentrated sulfuric acid.

456 g. of trimethylene glycol (b. p. 210–215°) and 1200 g. of concentrated sulfuric acid are next added in the order given, the sulfuric acid being added slowly. The mixture is refluxed during a period of three hours and is then subjected to distillation until no water-insoluble product appears in the distillate (about one hour).

The trimethylene bromide is purified as directed under "*n*-Butyl Bromide." A yield of 1088 g. boiling at 162–165° (90 per cent theory) is obtained. In a number of experiments, the lowest yield obtained was 88 per cent, whereas the maximum obtained was 95 per cent.

*Sodium Bromide Method.* The yields of trimethylene bromide by the sodium bromide method as described under "*n*-Butyl Bromide" are slightly lower than those given above. Thus, from 1350 g. of water, 1545 g. of sodium bromide, 456 g. of trimethylene glycol, and 2500 g. of sulfuric acid, a yield of 1110 g. of crude product is obtained, from which, after purification and distillation, a yield of 1030 g. of bromide (85 per cent theory) is obtained.

## 2. Notes

*Hydrobromic Acid.* In the sulfur-dioxide reduction of bromine, it should be noted that the proportion of water used depends upon whether the reduction mixture is to be distilled for the preparation of 48 per cent hydrobromic acid, or whether it is to be used directly for the manufacture of alkyl bromides.

During the first stage of the reduction, the flask should be shaken from time to time in order to avoid the accumulation of

sulfur dioxide, or possibly of sulfuryl bromide, which would result in a violent reaction due to a large quantity of the material reacting at one time. Although more than a hundred reduction experiments were conducted with quantities of bromine varying from 0.5 to 2 kg., this sudden reaction was noted in only one or two instances in spite of the fact that there was usually no agitation other than that furnished by the entering gas stream.

The intensity of the color in the reduced bromine solution depends somewhat on the quality of bromine used, and with the technical product special care is needed in noting the end-point of the reduction; i.e., the transition from the bromine color to a yellowish-brown color.

An excess of sulfur dioxide is to be avoided for the reason that evolution of gas during the distillation of the product will result in a considerable loss of alkyl bromide through volatilization. This loss is especially marked in the preparations of ethyl and allyl bromides if this precaution is not observed.

*Alkyl Bromides; General Discussion.* When an alcohol is heated with aqueous 48 per cent hydrobromic acid, a partial conversion takes place into the corresponding bromide. The reaction is, however, more rapid and more complete in the presence of sulfuric acid. Although the constant boiling hydrobromic acid obtainable on the market may be used in all the above experiments, its preparation by the sulfur-dioxide reduction of bromine will be considerably cheaper and equally convenient, provided a cylinder of sulfur dioxide is available. For use in the preparation of alkyl bromides, distillation of the bromine-sulfur dioxide reduction mixture is superfluous.

The method described is quite general for the preparation of primary bromides. The presence of sulfuric acid would usually be objectionable in the preparation of secondary and tertiary bromides because of the ease of dehydration of the corresponding alcohols. Moreover, these bromides may be obtained in good yields without the use of sulfuric acid.

The reaction mixture is heated under the reflux condenser for several hours preliminary to the first distillation of the alkyl

bromide. This is done in order to convert the alcohol as completely as possible into the corresponding bromide and thus to prevent its volatilization with the bromide. Direct distillation of the reaction mixture without refluxing will usually result in a decrease in yield of from 5-15 per cent. Alkyl bromides of low molecular weight may, however, be distilled directly from the reaction mixture without the necessity of refluxing, providing that the process of distillation is conducted very slowly. Alkyl halides of high molecular weight are separated from the reaction liquors mechanically instead of by distillation. This is done in order to avoid the decomposition due to heating the slightly volatile material with a gradually increasing concentration of sulfuric acid.

The favorable results obtained in the preparation of alkyl bromides with aqueous hydrobromic acid to which sulfuric acid has been added suggests that practically the same result might be accomplished by the use of sodium bromide, water, and sulfuric acid in such ratios as approximate the proportions used in the first instance. In actual practice this modified sodium bromide method was found fairly satisfactory for the preparation of butyl bromide and of trimethylene bromide. Slightly lower yields are due to the decreased solubilities of the alcohols in the reaction mixtures because of the presence of dissolved salts. One would therefore predict that with alcohols of still higher molecular weights, even lower yields would be obtained with the sodium bromide method. This prediction was substantiated in experiments with *iso*-amyl alcohol, where the sodium bromide method gave yields of only 70 per cent of the theory, whereas the hydrobromic acid method gave yields of almost 90 per cent. The sodium bromide method is therefore not recommended for the preparation of alkyl bromides of high molecular weight.

The main impurities usually found in alkyl halides are the corresponding alcohols and ethers. Cold concentrated sulfuric acid is an efficient reagent for the removal of these impurities in all cases where the alkyl halide itself is not attacked by this reagent. Whenever a product contains a considerable quantity

of unchanged alcohol, several washings with the cold concentrated acid may be required.

Trimethylene bromide prepared by direct distillation of the reaction mixture without the preliminary refluxing period contains appreciable amounts of trimethylene bromohydrin. In the purification of trimethylene bromide with sulfuric acid the high specific gravity of the former (1.087) must be borne in mind. Vigorous shaking with sulfuric acid may result in the formation of emulsions.

In the preparation of allyl bromide, appreciable loss may occur, not only because of carbonization but primarily because of the reaction of the allyl bromide with hydrobromic acid to form propylene bromide. Stirring during the formation of the alkyl bromide prevents the formation of two layers in the reaction mixture and thus assures a rapid and smooth distillation. An efficient condenser is of course essential.

In the experiments described, a more dilute hydrobromic acid solution may be used, provided that the proportion of sulfuric acid is increased. Aqueous solutions of alcohols may also be used, provided a suitable adjustment is made of the proportion of sulfuric acid. In the allyl alcohol experiment, material was used as obtained from the glycerol-formic acid preparation after one salting-out with potassium carbonate.

In many organic preparations too large a quantity of drying agent is usually employed, with the resulting loss of a considerable amount of material due to absorption by the drying agent. In the present experiments it is found that after a careful separation of the alkyl halide from the water layer as small a quantity as 15 g. of calcium chloride is sufficient for the drying of 1500 g. of alkyl halide.

Mechanical stirring is often avoided in most university laboratories and since it is so important in obtaining successful yields, it will be specified in many experiments. In Fig. 1 (p. 4) (a) and (b) represent two convenient types of stirring devices<sup>1</sup> where refluxing and stirring are desired at the same time. When the stopper of the flask is so small that it will hold only the

<sup>1</sup> Ber. 37, 023 (1004).

mechanical stirrer, a Y-tube such as is shown in Fig. 2, (b) fitted with either form of stirrer is suitable. It often happens that a separatory funnel or thermometer must also be inserted in the flask in addition to the reflux condenser. A flask such as is shown in Fig. 2, (a) is especially convenient, the middle

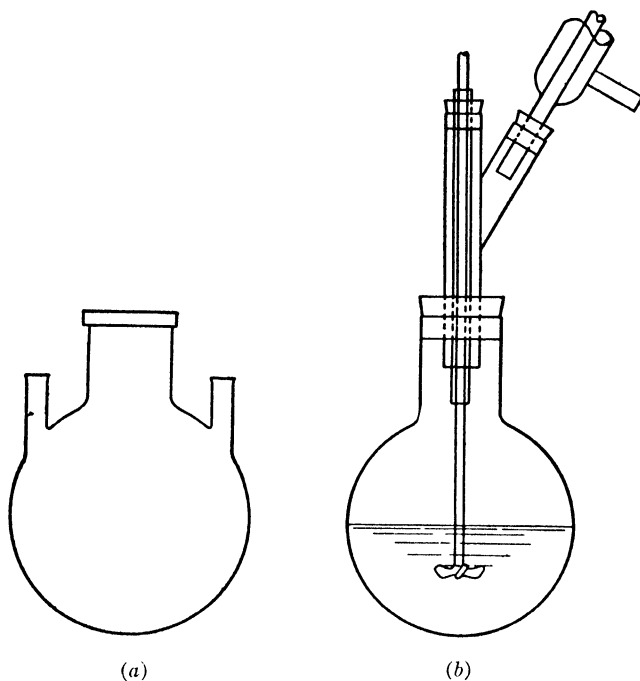

FIG. 2.

opening being used for the stirrer, the two smaller ones for thermometer and reflux condenser.

### 3. Other Methods of Preparation

Alkyl halides are prepared most conveniently from the corresponding alcohols. The methods commonly employed are (a) by the action of phosphorus bromide,<sup>1</sup> (b) by the action of a

<sup>1</sup> Ann. chim. phys. (2) **34**, 99 (1827); Ann. **30**, 298 (1839); **56**, 146 (1845); **93**, 114 (1855).

metallic bromide and sulfuric acid,<sup>1</sup> (*c*) by the action of very concentrated or fuming hydrobromic acid often under pressure,<sup>2</sup> and (*d*) by the action of aqueous hydrobromic acid according to the method suggested by Norris.<sup>3</sup>

Bodroux<sup>4</sup> has prepared allyl, propyl, and isobutyl bromides by means of a modified Norris method. Bromine was reduced by means of sulfur dioxide, the alcohol was added and the mixture distilled. The yields were not the highest, however. The method described above is an improvement of the Norris-Bodroux method. Two essential modifications consist in the addition of concentrated sulfuric acid, and in the recommendation of a refluxing period preliminary to the distillation. The sodium bromide method has been improved by the introduction of similar modifications.

Two papers<sup>5</sup> have appeared recently aiming at the improvement of the preparation of ethyl bromide. Although the preparation of allyl bromide was studied as recently as 1913, yields of only 60–85 per cent are reported by Claisen and Eisleb.<sup>6</sup>

For the preparation of trimethylene bromide, the most convenient laboratory method in the past has been the addition of hydrobromic acid to allyl bromide;<sup>7</sup> it has also been made by the action of gaseous and aqueous hydrobromic acid on glycerol.<sup>8</sup> Since trimethylene glycol is at the present time a by-product obtained from the purification of glycerol, a more convenient and practical method for the preparation of trimethylene bromide consists in the utilization of the corresponding glycol. A method involving the use of gaseous hydrogen bromide has recently been described,<sup>9</sup> but the aqueous hydrobromic-sulfuric acid method<sup>10</sup> is found to be a considerable improvement.

<sup>1</sup> *J.* **1857**, 441.

<sup>2</sup> *Ann.* **136**, 41 (1865); **158**, 161 (1871); **159**, 73 (1871).

<sup>3</sup> *Am. Chem. J.* **38**, 639 (1907); *J. Am. Chem. Soc.* **38**, 1075 (1916).

<sup>4</sup> *Compt. rend.* **160**, 206 (1915).

<sup>5</sup> *J. Chem. Soc.* **107**, 1489 (1915); **109**, 1 (1916).

<sup>6</sup> *Ann.* **401**, 27 (1913).

<sup>7</sup> *Ann.* **158**, 370 (1871); *Ann.* **197**, 179 (1879).

<sup>8</sup> *Monatsh.* **2**, 639 (1881).

<sup>9</sup> *J. Am. Chem. Soc.* **40**, 546 (1918).

<sup>10</sup> *J. Am. Chem. Soc.* **43**, 2228 (1922).



## II

### ALLYL ALCOHOL

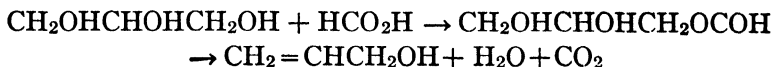

Prepared by OLIVER KAMM and C. S. MARVEL.  
Checked by H. T. CLARKE and E. R. TAYLOR.

#### 1. Procedure\*

IN a 5-l. round-bottom flask are placed 2 kg. of glycerol and 700 g. of technical 85 per cent formic acid. The flask is connected with a condenser set for downward distillation and the temperature within the reaction mixture is indicated by a thermometer, the bulb of which is immersed in the liquid. It is advisable to use as a receiver a boiling flask attached tightly to the lower end of the condenser. A tube is then run from the side arm of the boiling flask to a bottle of strong caustic soda to dissolve and decompose any acrolein which may be formed; a few pieces of clay plate are added to the distillation flask in order to prevent bumping, and it is then heated rapidly over a good ring burner. The first runnings should come over within fifteen minutes and a temperature of 195° should be reached within from thirty to forty-five minutes. Slow heating causes charring and formation of much acrolein, and thus gives a very low yield of allyl alcohol. The distillate collected up to the point where the thermometer registers 195° is saved separately. The heating of the reaction mixture is continued until the temperature reaches 260°, the main reaction taking place at from 225° to 235°. At this point, when the heating should be stopped, a white smoke appears and decomposition apparently begins. The distillate (about 750 cc.) coming over between the ther-

\* See Org. Syn. 6, 103, for additional information concerning the preparation of allyl alcohol.

mometer readings of from 195–260° is saved. For this operation about four hours are required. The contents of the flask are now allowed to cool to a temperature between 100° and 125° and 500 g. more of the technical 85 per cent formic acid are added. The distillation is then repeated in exactly the same manner as described above and 500 cc. of distillate are collected between the temperatures from 195–260°. The reaction mixture is allowed to cool again and a third portion of 500 g. of formic acid is added. This distillation yields not more than 350 cc. of the desired fraction, and this low yield indicates that the glycerol is used up and that further addition of formic acid is unnecessary; moreover, the residue left behind is now small, amounting only to 100 to 200 cc. The three distillations require from one to one and a half days.

The 195–260° fractions of the distillates are treated with potassium carbonate to salt out the allyl alcohol and to neutralize the little formic acid present. This allyl alcohol is then distilled and the fraction boiling up to about 103° is collected, or if a column is used, up to 98°. In this way, 845 g. of an allyl alcohol are obtained, which by a bromine titration shows a purity of about 68–70 per cent. This is equivalent to 570 to 590 g. of pure allyl alcohol (45–47 per cent theory).

The alcohol may be made practically anhydrous by refluxing with successive portions of fused potassium carbonate until no further action is observed. The carbonate will remain finely divided and will not become sticky when water is absent. A considerable amount of allyl alcohol is lost mechanically during the drying in this way, so that the potassium carbonate which is used here should be employed for the salting out of fresh portions of allyl alcohol in the first part of subsequent preparations. The allyl alcohol thus produced is dry enough for all practical purposes (98–99 per cent) and it is unnecessary to dry with lime or barium oxide as advised in the literature in order to remove all of the water. The allyl alcohol obtained by this process boils at 94–97°.

Clarke and Taylor have used the following method with success for obtaining a completely anhydrous product. The

allyl alcohol obtained after one salting out with potassium carbonate is distilled as indicated above to give a product of about 70 per cent purity and then mixed with 0.25 of its volume of carbon tetrachloride. The mixture is then slowly distilled from a round-bottom flask fitted with a fractionating column at least 80 cm. long, collecting the low boiling mixture of carbon tetrachloride, water, and allyl alcohol, drying it with potassium carbonate, and returning it to the flask. This process is repeated several times, until only very little water passes over. The mixture is then completely distilled, taking the following cuts:  $-80^{\circ}$ ,  $80-90^{\circ}$ ,  $90-95^{\circ}$ ,  $95.5-97^{\circ}$ , the last being alcohol which titrates 100 per cent pure. The lower fractions are dried separately and refractionated, thus giving an additional portion boiling  $95.5-97^{\circ}$ .

## 2. Notes

The reaction between formic acid and glycerol runs very smoothly and without the tendency toward foaming which results when oxalic acid is used.

The lower fraction which distils up to the point where the thermometer registers  $195^{\circ}$  contains a considerable amount of formic acid and in large scale production it would undoubtedly pay to recover it.

To determine the purity of any sample of allyl alcohol, 1 cc. is run into 15 to 25 cc. of carbon tetrachloride and this solution is then treated in the cold with a carbon tetrachloride solution of bromine (standardized with potassium iodide and sodium thio-sulfate) until a permanent bromine coloration is obtained. The amount of allyl alcohol present in any solution may also be determined roughly by conversion to allyl bromide. From several experiments it was found that the allyl bromide obtained was equivalent to the amount of allyl alcohol as determined by bromine titration.

A large amount of work was carried out upon the oxalic acid and glycerol method for the production of allyl alcohol. The results, however, were not satisfactory and therefore are not included here. It might be said, however, that when oxalic

acid is used in place of formic acid, the reaction requires a longer time for completion and is not nearly so smooth. There is a much greater tendency toward foaming and the reaction must be continually watched in order to prevent this, especially after the first distillation with oxalic acid, when more oxalic acid is added and heating is continued. Another disadvantage is that large amounts of acrolein are produced when oxalic acid is used. In general, the yield by this method amounts to not over 20-30 per cent, whereas with formic acid a yield of 45-50 per cent is easily obtained. As far as the preparation of allyl alcohol is concerned, in amounts such as are used in the above experiments, the formic acid method is greatly to be preferred. The method of employing anhydrous oxalic acid, which has been reported as giving particularly good yields, did not give satisfactory results when tried.

Experiments were also made with 90 per cent formic acid and yields of 50-54 per cent of allyl alcohol were obtained. The importance of heating the original reaction mixture rapidly should be again emphasized.

### 3. Other Methods of Preparation

The methods for making allyl alcohol are many. It may be prepared by (a) the action of metals upon dichlorohydrin;<sup>1</sup> (b) the reduction of acrolein;<sup>2</sup> (c) the action of potassium hydroxide on trimethylene bromide;<sup>3</sup> (d) the catalytic decomposition of glycerol with aluminum oxide;<sup>4</sup> (e) the hydrolysis of allyl iodide;<sup>5</sup> (f) the decomposition of glycerol triformate;<sup>6</sup> (g) the action of formic acid upon glycerin;<sup>7</sup> and (h) the action of

<sup>1</sup> Ann. chim. phys. (3) **67**, 323 (1863); Ann. **159**, 173 (1871); Z. Chem. **4**, 259 (1868).

<sup>2</sup> Ann. Spl. **3**, 258 (1864); Ber. **45**, 3316 (1912).

<sup>3</sup> J. Russ. Phys. Chem. Soc. **45**, 568 (1913); Chem. Zentr. **1913**, II, 1374.

<sup>4</sup> Compt. rend. **166**, 1033 (1918).

<sup>5</sup> Ann. **102**, 288 (1857).

<sup>6</sup> Z. physik. Chem. **70**, 460 (1910).

<sup>7</sup> Ann. **156**, 139 (1870); Bull. soc. chim. (4) **13**, 1103 (1913); C. A. **10**, 1035 (1916).

oxalic acid upon glycerin.<sup>1</sup> Of these methods, the two most practical for the preparation of allyl alcohol upon a large scale are by the action upon glycerol of either formic or oxalic acid. Both have been studied, with the result that the formic acid method is shown to be much the superior.

The use of mixtures of glycerol and formic acid for the preparation of allyl derivatives (allyl chloride and allyl formate) has recently been described by Aschan.<sup>2</sup> Allyl alcohol has also been isolated from crude wood alcohol.<sup>3</sup> A special method for titrating allyl alcohol has been described.<sup>4</sup>

<sup>1</sup> Ann. chim. phys. (6) **22**, 464 (1891); Ann. **167**, 222 footnote (1873); **156**, 134, 149 (1870); J. Chem. Soc. **105**, 151 (1914); **107**, 407 (1915).

<sup>2</sup> C. A. **13**, 2868 (1919).

<sup>3</sup> Ber. **7**, 1381, 1493 (1874); Z. angew. Chem. **22**, 2037 (1909).

<sup>4</sup> Monatsh. **39**, 617 (1918).



### III

#### BENZENE SULFONYL CHLORIDE

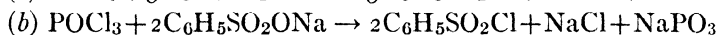
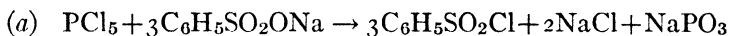

Prepared by ROGER ADAMS and C. S. MARVEL.  
Checked by H. T. CLARKE and W. W. HARTMAN.

#### 1. Procedure

(a) Phosphorus Pentachloride Method:—In a 2-l. round-bottom flask is placed a mixture of 250 g. (1.15 moles) of finely divided phosphorus pentachloride and 450 g. (2.5 moles) of sodium benzene sulfonate which has previously been dried for three hours at  $140^\circ$ . The mixture is heated in an oil bath at  $170$ – $180^\circ$  for fifteen hours. It is advisable to have a reflux condenser attached to the flask, although very little active refluxing takes place. Every four hours during the heating period, the flask should be removed from the oil bath, cooled for fifteen minutes, stoppered and shaken thoroughly until the mass becomes pasty (sometimes ten to fifteen minutes are required to accomplish this). At the end of the heating period, the mixture is cooled and 1 l. of water with 1 kg. of cracked ice are added. Benzene sulfonyl chloride sinks to the bottom, is separated, washed once with water, filtered if necessary, and vacuum distilled for purification. The forerun, consisting of a little chlorobenzene, water, and a little benzene sulfonyl chloride is discarded and the fraction boiling between  $145$ – $150^\circ$  at 45 mm. is collected. This weighs in the different runs from 330 to 360 g. (75–80 per cent theory).

The yields in this experiment are likely to vary widely on account of the variability in the different samples of sodium

benzene sulfonate. With certain samples a solid impurity is left as a residue from the distillation of the crude benzene sulfonyl chloride.

(b) Phosphorus Oxychloride Method:—Benzene sulfonyl chloride may be prepared by the same procedure described above from a mixture of 270 g. (3 moles) of sodium benzene sulfonate and 180 g. (2.25 moles) of phosphorus oxychloride. It is advisable to observe the same precaution about shaking every few hours. The yield of finished product boiling 145–150° at 45 mm. amounts to 195 to 230 g. (75–90 per cent theory).

## 2. Notes

It is advisable to heat the mixture just described as long as fifteen hours to be certain that the reaction is complete. The reaction is chiefly over, however, at the end of ten hours.

The temperature must be maintained at 170°. A lower temperature does not give so good a yield.

If a means of mechanical stirring were provided, the yields would undoubtedly be much better, and the time required shorter. The mixtures, however, are so thick that in the laboratory mechanical stirring is impracticable.

Experiments using a larger excess of phosphorus pentachloride or phosphorus oxychloride were used but no particular advantage was so obtained.

## 3. Other Methods of Preparation

Benzene sulfonyl chloride may be made by the action of phosphorus pentachloride upon benzene sulfonic acid or its salts;<sup>1</sup> by the action of phosphorus oxychloride upon the salts of benzene sulfonic acid;<sup>2</sup> by the action of chlorosulfonic acid upon benzene;<sup>3</sup> by the action of chlorosulfonic acid upon the

<sup>1</sup> Ann. 87, 299 (1853); 119, 143 footnote (1861); 275, 233 (1893); Z. chem. 1866, 106; Ber. 5, 876 (1872); Rec. trav. chim. 18, 432 (1899).

<sup>2</sup> Compt. rend. 35, 690 (1852).

<sup>3</sup> Z. Chem. 1869, 41; Ber. 4, 356 (1871); 11, 2061 (1878); 12, 1848 (1879); 42, 1802, 2057 (1909).

sodium salts of benzene sulfonic acid.<sup>1</sup> Since the sodium benzene sulfonate is a commercial product which may be obtained from the phenol manufacturers, the conversion of it into the sulfonyl chloride has been especially studied. In the laboratory manuals, the directions generally involve the action of 1 mole of phosphorus pentachloride upon 1 mole of sodium benzene sulfonate. This method requires that the large amount of phosphorus oxychloride formed be destroyed or distilled off, a process which not only requires considerable time, but which is also rather wasteful. It is much more economical, however, to treat sodium benzene sulfonate with phosphorus pentachloride in such proportions that the phosphorus oxychloride which is produced in the initial reaction will convert more sodium benzene sulfonate into benzene sulfonyl chloride. This method is, to be sure, described in the literature and it is claimed that nearly quantitative yields are obtained. It was impossible with the grade of sodium benzene sulfonate which was available to duplicate these published results. It is also possible to produce benzene sulfonyl chloride by the action of phosphorus oxychloride upon sodium benzene sulfonate and the yields in this case were about the same as when phosphorus pentachloride was used. These last two methods are better than the original one because with no phosphorus oxychloride or pentachloride to destroy, working up of the crude material is very easy.

Although it is claimed in the literature that chlorosulfonic acid and benzene give good yields of benzene sulfonyl chloride it was found that a large excess of chlorosulfonic acid was necessary; also that much greater precautions must be taken in carrying out the reaction. If very large amounts of benzene sulfonyl chloride were needed, it would probably be advisable to study this latter reaction intensively with the possibility of developing it satisfactorily.

<sup>1</sup> Ber. 15, 1118 (1882).



## IV

### BENZIL



Prepared by ROGER ADAMS and C. S. MARVEL.  
Checked by J. B. CONANT and C. E. BILLS.

#### 1. Procedure\*

IN a 3-l. round-bottom flask are placed 410 g. of crude benzoin and 1 l. of nitric acid (sp. gr. 1.42), (2.5 cc. of nitric acid per gram of benzoin). The mixture is heated on a water bath for about one hour with occasional shaking, until the evolution of oxides of nitrogen ceases. The reaction mixture is then poured with stirring into four to five times its volume of cold water; the benzil precipitates as small yellow lumps. The crude product is filtered and washed several times with water to remove the nitric acid. The yield after drying is 390 to 395 g. (96-97 per cent theory). Absolutely pure benzil may be obtained by crystallization from an alcohol solution. 390 g. of the crude benzil may be dissolved in about 1 l. of boiling alcohol: and since pure benzil is quite insoluble in cold alcohol, there is no difficulty in obtaining 370 g. of the pure product from the 390 g. used.

#### 2. Notes

A number of experiments upon the oxidation of benzoin to benzil with nitric acid were made in which the mixture was stirred continuously. An inferior grade of product and smaller yields (seldom over 75 per cent) were obtained. The probable reason for this is to be found in the fact that benzoin is readily soluble in nitric acid while the benzil is not, and the latter there-

\* See Org. Syn. 6, 6, for a second and perhaps more satisfactory method of preparing benzil.

fore floats on the top as soon as it has formed. If a stirrer is employed, it tends to bring the precipitated benzil into intimate contact with the nitric acid, causing some of it to become further oxidized or nitrated, and thus reducing the yield and quality of the product.

In E. Fischer's "Anleitung zur Darstellung Organischer Präparate" 8th edition (1908) p. 35, the following test is given to determine when all the benzoin has been oxidized. A drop of the oil is treated with water to cause it to solidify. The crystals thus produced are dissolved in alcohol, diluted with water, a little Fehling's solution is added and the mixture is heated to 60-70°. If benzoin is present, cuprous oxide is precipitated. In general, however, the test is unnecessary and the cessation of the evolution of oxides of nitrogen is a satisfactory end-point.

### 3. Other Methods of Preparation

Benzil is very readily formed by the oxidation of benzoin, with nitric acid,<sup>1</sup> a method first described by N. Zinin. Various other oxidizing agents<sup>2</sup> may be employed, but according to the literature none of these give entirely satisfactory results; they have therefore not been investigated. Other methods for preparing benzil, obviously of theoretical importance only as compared with the oxidation of benzoin, have appeared but have not been studied. Thus preparations have been carried out by the action of acetic acid and zinc<sup>3</sup> or of heat on benzoin;<sup>4</sup> by the action of boiling water on toluene dibromide<sup>5</sup> or stilbene dibromide;<sup>6</sup> by the action of sulfuric acid or acetic acid upon toluene tetrachloride;<sup>7</sup> by the action of cyanogen on benzene in the

<sup>1</sup> Ann. **34**, 188 (1840).

<sup>2</sup> With chlorine, Ann. **17**, 91 (1836); electrolytic oxidation, J. Am. Chem. Soc. **21**, 893 (1899).

<sup>3</sup> J. Chem. Soc. **71**, 219 (1897).

<sup>4</sup> Ber. **30**, 2923 (1897).

<sup>5</sup> Ber. **4**, 380 (1871).

<sup>6</sup> Ann. **145**, 338 (1868).

<sup>7</sup> Ber. **12**, 1975 (1879).

presence of aluminum chloride;<sup>1</sup> by the nitration of acetyl benzoin and stilbene-diol diacetates;<sup>2</sup> by the hydrolysis of hydrazobenzil.<sup>3</sup>

<sup>1</sup> Ber. **44**, 2457 (1911).

<sup>2</sup> J. Chem. Soc. **99**, 345, 348 (1911).

<sup>3</sup> J. prakt. Chem. (2) **83**, 217, 226, 232 (1911).



## V

### BENZILIC ACID

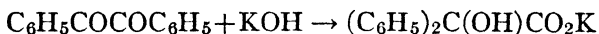

Prepared by ROGER ADAMS and C. S. MARVEL.  
Checked by J. B. CONANT and C. E. BILLS.

#### 1. Procedure

IN a 5-l. round-bottom flask, 350 g. of potassium hydroxide are dissolved in 700 cc. of distilled water, and 700 g. of alcohol (95 per cent) and 350 g. of pure benzil are added. A deep bluish-black solution is produced. The mixture is placed on a steam bath and is boiled under a reflux for ten to twelve minutes. The contents of the flask are now poured into a large porcelain dish and are allowed to cool, preferably overnight. The potassium salt of benzilic acid soon begins to crystallize and is almost completely precipitated at the end of this time. This salt is filtered off and is washed with a little alcohol. The alcoholic mother liquors, if concentrated, will yield upon standing a small additional amount of potassium salt. The salt is now dissolved in about 3 to 4 l. of water and hydrochloric acid is added slowly with stirring. The portion of the precipitate which is produced by the first 10 cc. of hydrochloric acid (sp. gr. 1.19) is colored reddish brown and is slightly sticky. This should be filtered off; if the procedure has been carried out correctly, the filtrate is nearly colorless. Hydrochloric acid is now added until the precipitation is complete and the benzilic acid is filtered off with suction, washed with cold water until free from chlorides, and dried. The yield is 290 to 300 g. (77-79 per cent theory). The acid is generally a light pinkish yellow and is best purified by recrystallization from benzene. The purification may also be

accomplished by crystallizing from hot water with the use of bone-black or by dissolving in alkali and reprecipitating by means of hydrochloric acid as described above. The product forms needles, m. p. 150°. By boiling the red sticky material which is precipitated by the first portion of hydrochloric acid, with water and 7 g. of bone-black, an additional yield of 10 to 20 g. of pure benzilic acid is obtained.

## 2. Notes

The benzil used must be pure, such as is obtained by recrystallization from alcohol. A number of experiments which were carried out with crude benzil which had merely been washed with water did not give nearly such good yields.

If the potassium salt is not isolated but the reaction mixture is immediately acidified, there is mixed with the benzilic acid a certain amount of benzoic acid which is difficult to remove. This may be done either by fractional solution in sodium carbonate<sup>1</sup> (benzilic acid is a stronger acid than benzoic), by shaking with ligroin,<sup>2</sup> which extracts the benzoic acid from the benzilic, or by boiling with water<sup>3</sup> for some time until the odor of benzoic acid has disappeared. It is better to isolate the potassium salt, since upon acidification very pure benzilic acid is obtained in spite of the fact that it is slightly colored.

In the preparation of certain benzilic acid derivatives from substituted benzils, it has been found that simply dissolving the substituted benzil in alcoholic alkali is sufficient to complete the conversion and no heating is required. With unsubstituted benzil, however, a much poorer yield of benzilic acid is obtained if the reaction mixture is not heated. Longer heating than that given in the directions is likely to decompose some of the product to benzoic acid.

The amount of alcohol and the concentration is such that the maximum amount of potassium benzilate will crystallize out.

<sup>1</sup> Ann. 155, 79 (1870).

<sup>2</sup> Ann. 356, 71 (1907).

<sup>3</sup> E. Fischer's "Anleitung zur Darstellung Organischer Präparate" 8th edition, p. 36.

If more alcohol is used in proportion to the water, a large amount of potassium salt crystallizes during the heating and this is objectionable, while less alcohol holds in solution a considerable amount of potassium benzilate and thus decreases the yield.

Benzilic acid is soluble to the extent of 2 per cent in hot water and 0.1 per cent in cold water. By using 20 per cent alcohol, the solubility is increased so that from 100 cc. of solvent 5 g. of pure product may be obtained. Stronger alcohol is not a suitable solvent as the benzilic acid separates from it as an oil. Benzene is the most satisfactory solvent, since 100 cc. dissolve 15 g. at the boiling temperature and yield 13 g. of pure product on cooling.

Sodium hydroxide is not suitable since the sodium salt of the benzilic acid does not crystallize from the reaction mixture.

The 10 cc. of hydrochloric acid specified in the above directions as the amount necessary to precipitate the reddish impure material is an average quantity. In some experiments a little more hydrochloric acid, in some a little less is needed; a pale straw colored liquid should result after the first oil has been precipitated.

### 3. Other Methods of Preparation

Benzilic acid has been made by the action of potassium hydroxide on benzil, either in concentrated aqueous solution<sup>1</sup> (described first in a paper by M. Bösler and later in papers by H. Klinger and by H. Staudinger) or in alcoholic solution<sup>2</sup> (described by J. Liebig, N. Zinin, A. Jena and H. v. Liebig) and either one of these processes furnishes a method for producing benzilic acid cheaply and in large amounts. The other methods by which it may be made are the action of alcoholic potash upon isobenzil;<sup>3</sup> the hydrolysis of diphenyl-bromoacetic acid;<sup>4</sup> the action of alkalis upon benzoin;<sup>5</sup> the action of sodium on benzophenone.<sup>6</sup>

<sup>1</sup> Ber. **14**, 326 footnote (1881); **22**, 1212 (1889); Ann. **356**, 71 (1907).

<sup>2</sup> Ann. **25**, 27 (1838); **31**, 329 (1839); **155**, 79 (1870); especially Ber. **41**, 1644 (1908).

<sup>3</sup> Ber. **19**, 1363 (1886).

<sup>4</sup> Ann. **171**, 131 (1873).

<sup>5</sup> Ber. **19**, 1868 (1886).

<sup>6</sup> Am. Chem. J. **29**, 607 (1903).

The action of alcoholic potash on benzil has been chosen for special study since less impurity is formed than when aqueous potash is used. The benzilic acid made by the aqueous alkali method is generally deeply colored and the color is rather difficult to remove.

Although the yields with this aqueous alkali method are high with small runs, they decrease when 300 to 500 g. of benzil are used; moreover, the danger of contamination with benzoic acid is always greater. It was found that with runs of 350 to 500 g. of benzil, the yields of benzilic acid, using the alcoholic alkali method of H. v. Liebig given above, were never as good as those described in the literature; with small amounts of material (up to 100 g.) however, yields often over 90 per cent were obtained. It has been stated in the literature<sup>1</sup> in one of the more recent articles (using aqueous potassium hydroxide) that occasionally poor runs resulted, and it has been found in this investigation that every now and then a low yield will result.

<sup>1</sup> Ann. **356**, 71 (1907).

## VI

### BENZOIN

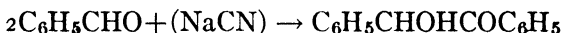

Prepared by ROGER ADAMS and C. S. MARVEL.

Checked by J. B. CONANT and C. E. BILLS.

#### 1. Procedure\*

IN a 3-l. round-bottom flask fitted with a reflux condenser, 625 cc. of alcohol (95 per cent), 500 cc. of water, 500 g. of pure benzaldehyde and 50 g. of sodium cyanide (96-98 per cent) are placed. This mixture is then heated and kept boiling for 0.5 hour. In the course of about twenty minutes, crystals begin to separate from the hot solution. At the end of the thirty minutes, the solution is cooled, filtered with suction, and washed with a little water. The yield of dry crude benzoin, which is white or light yellow, amounts to 450 to 460 g. (90-92 per cent theory). In order to obtain it completely pure, the crude substance is recrystallized from alcohol, 90 g. of crude material being dissolved in about 700 cc. of boiling alcohol; upon cooling, a yield of 83 g. of white, pure benzoin is obtained, m. p. 129°.

#### 2. Notes

It is absolutely necessary that pure benzaldehyde be used for this reaction. The crude benzaldehyde which is obtained on the market should be washed with sodium carbonate solution, dried, distilled, and a fraction collected at 178-180°. Crude material will never give much more than a 50 per cent yield of benzoin.

The above directions require 50 per cent of the amount of dilute alcohol which is ordinarily recommended in the literature.

\* See *Org. Syn.* **6**, 103, for a slight change in procedure.

This allows one to prepare just double the amount of material in the same sized flask. The product obtained in this way, however, is slightly yellower than that obtained when more alcohol is used, but upon recrystallization it gives just as pure a product as that obtained by recrystallization of crude material made in the presence of more solvent. The results of many experiments lead to the conclusion that if large amounts of benzoin are to be prepared, the method described above is the better one. If, however, only a small amount is needed and a good grade of crude material is satisfactory, the larger amount of solvent is perhaps more desirable.

Several times when benzoin was being prepared, the condensation took place and was complete after boiling five to ten minutes or even less, the product separating out in the hot solution with evolution of heat. The yield under these conditions was always good and the color better than when the reaction took a longer time. The cause of this occasional rapid reaction was not discovered, but it was probably due to inoculation with a little benzoin in certain of the experiments. When it takes place as just described, the flask and efficient condenser used will be sufficient to condense the sudden, rapid evolution of alcohol vapors caused by the heat of crystallization of the benzoin.

### 3. Other Methods of Preparation

The only good method for the preparation of benzoin<sup>1</sup> appearing in the literature is by the action of potassium cyanide upon an alcoholic solution of benzaldehyde, a method described first by Wöhler and later modified slightly by Zinin and Zincke. The other methods are of theoretical importance only and have, therefore, not been studied. Thus, by the reduction of benzil,<sup>2</sup> and by the oxidation of hydrobenzoin,<sup>3</sup> benzoin can be formed; it happens, however, that both benzil and hydrobenzoin are commonly made from benzoin.

<sup>1</sup> Ann. **3**, 276 (1832); **34**, 186 (1840); **198**, 151 footnote (1879); discussion of mechanism of reaction, Ber. **21**, 1346 (1888); Ann. **298**, 312 (1897); J. Chem. Soc. **83**, 1004 (1903).

<sup>2</sup> Ann. **119**, 177 (1861).

<sup>3</sup> Ann. **198**, 123 (1879).

## VII

### $\alpha$ -BROMONAPHTHALENE

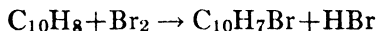

Prepared by H. T. CLARKE and ETHEL SCHRAM.  
Checked by ROGER ADAMS and M. E. MORALES.

#### 1. Procedure

IN an 8-l. crock are placed 2320 g. of naphthalene (flakes) and 2.5 l. of hot water. The temperature is brought to 40–50° and the mixture is vigorously stirred mechanically, while to it are added slowly 2900 g. (900 cc.) of bromine from a dropping funnel, the stem of which reaches to the bottom of the crock. No water jacket is necessary, the temperature of the mixture being kept at 40–50° by regulating the rate of addition of the bromine. The addition takes eight to nine hours but requires practically no attention. When all the bromine has been added, stirring is continued until the color has practically disappeared, at which time the mixture is allowed to cool and the heavy oil is separated. It is then heated in a 5-l. flask to 145–150° (oil bath) and a current of dry steam is passed in until 3 l. of distillate have been collected. This treatment eliminates hydrobromic acid from the bromine addition products and also removes some of the unchanged naphthalene.

The oil is then fractionally distilled under reduced pressure, and the main fraction which passes over at 132–135° at 12 mm. (145–148° at 20 mm.) is collected separately. The fore-runs on chilling yield naphthalene, which is filtered off and the filtrate is again distilled. The higher boiling portions on chilling yield dibromonaphthalene and the filtrate is again fractionated.

The united water solutions are distilled and 48 per cent hydrobromic acid boiling at 125–126° is collected. The yield of pure  $\alpha$ -bromonaphthalene varies from 2000 to 2200 g. and in certain cases reaches 2450 g., the yield of hydrobromic acid amounting to about 2650 g.

## 2. Notes

It is essential that the stirring should be efficient. A glass stirrer of the tube or propeller type answers satisfactorily, provided that the naphthalene flakes are not too coarse. As the reaction proceeds the product becomes oily, rendering the stirring more efficient.

The necessity of introducing the bromine at the bottom of the mixture should be emphasized. If this is not done, local overheating is almost certain to occur, with consequent loss of both bromine and hydrobromic acid.

If the distillation of  $\alpha$ -bromonaphthalene is carried on at atmospheric pressure, the product darkens on standing, but it does not do so if distilled under reduced pressure.

The higher boiling solid by-product contains, among other substances, 1, 4-dibromonaphthalene melting at 79–80°. This can be isolated by repeated recrystallization from carbon tetrachloride, but so many crystallizations are necessary that the final yield is low.

## 3. Other Methods of Preparation

$\alpha$ -Bromonaphthalene has been prepared by the action of bromine upon naphthalene without a solvent;<sup>1</sup> by the action of bromine upon naphthalene in carbon disulfide;<sup>2</sup> by treating a suspension of naphthalene in a solution of bromine in alkali with hydrochloric acid;<sup>3</sup> by the action of cyanogen bromide upon naphthalene at 250°;<sup>4</sup> by the action of bromine upon mer-

<sup>1</sup> Z. Chem. 1865, 3.

<sup>2</sup> Ann. 135, 40 (1865); 147, 166 (1868).

<sup>3</sup> Ber. 15, 2721 (1882).

<sup>4</sup> Ber. 10, 756 (1877).

cury dinaphthyl;<sup>1</sup> by the removal of the amino group from  $\alpha$ -bromo- $\beta$ -naphthylamine by diazotization.<sup>2</sup>

As methods of preparation, only the first three need be considered. It was decided not to try the direct action of bromine upon naphthalene, owing to the necessity of stirring the solid naphthalene and of collecting the hydrogen bromide gas; the latter difficulty is also presented when carbon disulfide is used, and the objectionable properties of this solvent make its use further unfavorable. The third method, in which a suspension of naphthalene in alkaline hypobromite solution is treated with hydrochloric acid in aqueous solution, was found to give satisfactory results in so far as the yield of  $\alpha$ -bromonaphthalene is concerned (though it was no better than with the method above described), but it presented considerable difficulties in the recovery of the hydrobromic acid.

<sup>1</sup> Ann. **147**, 175 (1868).

<sup>2</sup> Ber. **4**, 851 (1871).



## VIII

### *p*-BROMOPHENOL

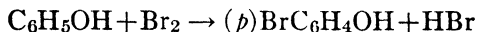

Prepared by ROGER ADAMS and C. S. MARVEL.

Checked by OLIVER KAMM and R. W. HUFFERD.

#### 1. Procedure

IN a 5-l. round-bottom flask fitted with a rubber stopper, holding a mechanical stirrer (Fig. 1, p. 4), reflux condenser and separatory funnel, are placed 1 kg. of phenol dissolved in 1 l. of carbon disulfide. To the top of the condenser is attached a calcium chloride tube and from this a glass tube leads into a beaker holding about 1200 cc. of cracked ice and water for the absorption of the hydrobromic acid evolved. In the separatory funnel are placed 1702 g. (546 cc. at 20°) of bromine dissolved in 500 cc. of carbon disulfide. The flask is well cooled (below +5°) in a salt and ice mixture, stirring is started, and the bromine solution is allowed to run in. The addition requires about two hours. When this is completed, the flask is disconnected and a condenser set for downward distillation is attached to it. By having a boiling flask as a receiver attached tightly to the lower end of the condenser, the dissolved hydrobromic acid which is evolved at the beginning of the heating may be led into the water used for collecting the first hydrobromic acid. The carbon disulfide is distilled off, and amounts to about 1200 cc. The residual liquid is then slowly distilled *in vacuo* with a good fractionating column in a 1.5- or 2-l. Claisen flask which must be slightly modified (Fig. 3, p. 40, see also Notes) so that the *p*-bromophenol after coming in contact with cork or rubber will not be carried into the condenser; if it does, it becomes pink-

ish. There are obtained from various runs 1475 to 1550 g. (80-84 per cent theory) of *p*-bromophenol boiling 145-150° at 25-30 mm., 250 to 350 g. of lower boiling material consisting of a mixture of *o*-bromophenol and *p*-bromophenol from which it is very difficult to extract either constituent in pure form, and finally a small quantity of high-boiling material consisting chiefly of 2,4-dibromophenol. The *p*-bromophenol on cooling solidifies to a

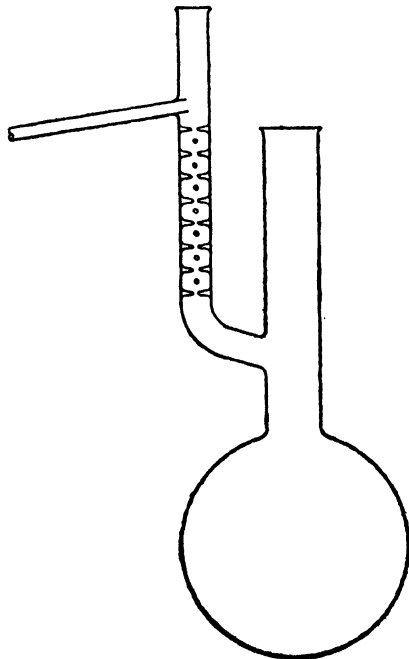

FIG. 3.

solid white mass containing practically no oil. By centrifuging the product, perfectly dry white crystals are obtained, m. p. 63°. There is also produced in this preparation about 1.5 to 1.6 l. of hydrobromic acid with a sp. gr. of about 1.3.

## 2. Notes

Although it is not absolutely necessary that the reaction mixture be cooled with salt and ice, it is highly desirable, since

this reduces the amount of *o*-bromophenol and hence the amount of low-boiling fraction; the recovery of carbon disulfide is also more satisfactory. A run of the same size as is described above was made, keeping the solution at room temperature, and under these conditions the yield of pure *p*-bromophenol was diminished.

The loss of carbon disulfide is due to its great volatility, the consequent passing off with the hydrobromic acid and the general loss during experimental manipulations.

The experiments may be run with a larger amount of carbon disulfide with satisfactory results. This, however, involves a longer time for distillation and is therefore undesirable. More concentrated solutions were not tried.

Moisture prevents the *p*-bromophenol from crystallizing, so that particular care should be taken to keep it out of the reaction mixture.

A complete run may be made in less than five hours.

The *p*-bromophenol if distilled without using a fractionating column and collected over a 5° range as already described will generally amount to 1600 to 1660 g. (87–90 per cent theory). This material on cooling, however, never solidifies completely but always contains a certain amount of oil; it is satisfactory for most purposes, just as it is. Even though the once-distilled material may be freed from oil and then redistilled without special fractionation, some oil remains. To obtain a very pure product this material must be cooled to 10° and then centrifuged. In this way, hard white crystals which melt sharply at 63° result. During this process about 15–20 per cent of the product goes to the filtrate which, however, can be chilled again so that a certain amount of pure *p*-bromophenol may be obtained from it. Although a number of solvents were used in an attempt to crystallize *p*-bromophenol, none was found which was entirely satisfactory.

The flask shown in Fig. 3 (p. 40) is particularly suited for distilling any liquids which have a great tendency to attack rubber or cork. It is a modification of one already described in the literature;<sup>1</sup> the side-arm outlet tube extends a short distance

<sup>1</sup> J. Am. Chem. Soc. **39**, 2718 (1917).

into the neck of the flask, thus preventing any vapor which has touched the cork or rubber from condensing and flowing down the side-arm into the receiver. This same device may, of course, be applied to any type of distilling flask.

### 3. Other Methods of Preparation

The methods for producing *p*-bromophenol are: the action of bromine on phenol in carbon disulfide;<sup>1</sup> the action of bromine on phenol in glacial acetic acid;<sup>2</sup> the action of bromine on phenol in a mixture of sulfuric acid and acetic acid;<sup>3</sup> the distillation of bromosalicylic acid with barium oxide and sand;<sup>4</sup> the action of bromocyanogen on phenol;<sup>5</sup> the diazotization of *p*-bromoaniline and subsequent heating with water.<sup>6</sup> Holleman<sup>7</sup> and Rinkes have recently studied the bromination of phenol in water, carbon tetrachloride, carbon disulfide and glacial acetic acid in order to determine the proportion of *o*- and *p*-bromophenols which are produced. Of the organic solvents there is little preference, as the maximum yield of para derivative in any of the solvents under ordinary conditions varies between 85 and 92 per cent. The temperature, however, has a marked effect. In carbon disulfide which seems to be slightly better than the other solvents, the yield of the para derivative varies from 97.3 per cent at  $-30^{\circ}$  to 86.2 per cent at  $+30^{\circ}$ .

In this investigation, the methods using bromocyanogen or bromosalicylic acid were not considered on account of the expense of raw materials. The diazotization of *p*-bromoaniline was studied, chiefly because it was anticipated that a very pure *p*-bromophenol might be obtained. This, however, was not the case, and, moreover, the yields were poor. The bromination of phenol in glacial acetic acid is satisfactory except that the acetic acid cannot be recovered conveniently. The bromination

<sup>1</sup> Ann. **137**, 200 (1866); Ber. **28**, 978 (1895).

<sup>2</sup> Ber. **6**, 171 (1873); Ann. **234**, 138 (1886).

<sup>3</sup> J. Chem. Soc. **85**, 1227 (1904).

<sup>4</sup> Ann. **52**, 338 (1844).

<sup>5</sup> Ber. **33**, 1555 (1900).

<sup>6</sup> Ber. **7**, 1176 (1874).

<sup>7</sup> Rec. trav. chim. **30**, 49 (1911).

in sulfuric acid (75 per cent) is unsatisfactory since the phenol does not dissolve readily at  $0^{\circ}$  and if a temperature high enough to dissolve it is used, a considerable amount of *o*-bromophenol is produced. As for the other solvents, carbon tetrachloride might seem preferable to carbon disulfide on account of its non-inflammability. It is not as good, however, as carbon disulfide, since it must be used in much larger amounts to dissolve the phenol at  $0^{\circ}$ , and since it is much less easily removed and the proportion of *o*-bromophenol is slightly greater.



## IX

### DIACETONE ALCOHOL

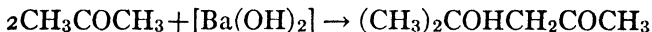

Prepared by J. B. CONANT and NEAL TUTTLE.

Checked by ROGER ADAMS and H. C. N. HECKEL.

#### 1. Procedure

A 2-l. round-bottom flask is fitted with a rubber stopper carrying a Soxhlet extractor which in turn is fitted with an efficient reflux condenser. 1500 cc. (1190 g.) of acetone (commercial grade) is placed in the flask and a few pieces of broken tile are introduced to produce even boiling. Two of the usual paper thimbles are placed in the extractor, one above the other. The lower one is filled nearly full of barium hydroxide; the top one is filled about three-quarters full of the same substance, and the remainder of the space is filled with glass wool. The flask is heated on a steam bath or in an oil bath. The heat is so regulated that the acetone refluxes back into the extractor rather rapidly. As the reaction proceeds the boiling-point of the mixture rises and more steam has to be turned on or the temperature of the oil bath has to be raised. The flask should finally be lowered as far as possible into the cone of the steam bath. The reaction is complete when the liquid no longer boils when heated as hot as possible on the steam bath. This usually requires ninety-five to one hundred and twenty hours. The refluxing may be interrupted at any time for as long as desired. The liquid in the flask has now a sp. gr. of about 0.91 (20°) which corresponds to about 80 per cent of diacetone alcohol. The only loss of material is by volatilization of the acetone through the top of the condenser; this generally amounts to several per cent.

The crude diacetone alcohol is purified by distillation. The 2-l. round-bottom flask is fitted with a three-bulb Glinsky fractionating column and a well-cooled condenser. The flask is heated in an oil bath, the temperature of which is gradually raised to  $125^{\circ}$ . The temperature of the bath is held at this point until no more acetone distils over, the temperature at the top of the column registering about  $70^{\circ}$  when the process is complete. The recovered acetone, containing a few per cent of diacetone alcohol, amounts to about 200 g. and can be used to prepare more material. The residual liquid has a sp. gr. of 0.928 ( $20^{\circ}$ ) and contains about 95 per cent of diacetone alcohol. It is transferred to a 2-l. Claisen flask and distilled under diminished pressure. A little acetone first comes over and then the diacetone alcohol distils smoothly at  $71-74^{\circ}$  at 23 mm. The yield is 850 g. (71 per cent of the theory based on the total acetone employed). The entire distillation requires about four hours.

## 2. Notes

Almost any form of a Soxhlet extractor and condenser will serve. It is advisable to use as much barium hydroxide as possible and to have the extractor empty as often and as completely as possible. The use of glass wool and care in filling the cups prevents any solid hydroxide from being carried down into the lower flask.

The use of tartaric acid in the flask has been recommended to neutralize any barium hydroxide that is carried down. This has been found unnecessary.

If hydrated barium hydroxide  $[\text{Ba}(\text{OH})_2 \cdot 8\text{H}_2\text{O}]$  is used in the thimbles this becomes dehydrated after one run; the anhydrous form is just as satisfactory and may be used over and over again.

The time of refluxing depends on the rapidity with which the liquid boils and on the way in which the Soxhlet extractor empties. Similarly, the point at which the liquid ceases to boil will vary somewhat with the way in which it is heated. The

amount of diacetone alcohol produced will, thus, vary somewhat in similar experiments. Refluxing for forty to fifty hours produces about a 70 per cent mixture which is perfectly suitable for preparing the pure product, except that more acetone is recovered unchanged.

Acetone and diacetone alcohol are in equilibrium with each other. The speed of both reactions is greatly accelerated by the presence of a base. The equilibrium mixture contains only a few per cent of diacetone alcohol but the dissociation of diacetone alcohol to acetone proceeds so slowly in the absence of barium hydroxide that it is possible to increase the concentration to 80 per cent by this procedure.

With some samples of commercial acetone containing considerable water, it has been found advisable to dry the acetone first with calcium chloride. This is usually not necessary.

The final distillation of diacetone alcohol must be carried out under diminished pressure as otherwise some of the material decomposes into acetone.

### 3. Other Methods of Preparation

The methods for producing diacetone alcohol are: the action of barium hydroxide on acetone;<sup>1</sup> the action of calcium hydroxide on acetone;<sup>2</sup> the action of concentrated sodium hydroxide or potassium hydroxide on acetone;<sup>3</sup> the action of magnesium amalgam on acetone;<sup>4</sup> and the action of nitrous acid on diacetoneamine.<sup>5</sup> The last method was not considered because of the difficulty of preparing diacetoneamine. Of the methods employing acetone only, the first two seemed more promising, since the others are reported as giving low yields of impure product. It was soon found that barium hydroxide acted more rapidly than calcium hydroxide (as reported by L. P. Kyriakides) and this method was therefore employed.

<sup>1</sup> J. Am. Chem. Soc. **36**, 534 (1914).

<sup>2</sup> D. R. P. 229,678; *Frdl.* **10**, 938 (1910-12); C. A. **8**, 788 (1914); U. S. pat. 1,550,792 (1925); C. A. **20**, 51 (1926).

<sup>3</sup> *Ann.* **169**, 114 (1873); *Z. physik. Chem.* **33**, 130 (1900); *Ann. chim. phys.* (9), **19**, 32 (1923).

<sup>4</sup> *Ann. chim. phys.* (8), **21**, 411 (1910).

<sup>5</sup> *Ann.* **178**, 342 (1875); *Ber.* **34**, 2856 (1901).



## X

### FURFURAL

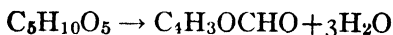

Prepared by ROGER ADAMS and V. VOORHEES.  
Checked by H. T. CLARKE and E. R. TAYLOR.

#### 1. Procedure\*

IN a 12-l. round-bottom flask are placed 1500 g. of corn cobs (ground to about the size of corn kernels), 5 l. of 10 per cent sulfuric acid and 2 kg. of salt. The flask is shaken in order to secure a homogeneous mixture and is then connected with an upright tube water condenser and return tube as shown in Fig. 4 (p. 50). Heat is applied from a ring burner, the flame being adjusted so that the liquid distils at a rapid rate.

The distillation process is continued until practically no more furfural can be seen collecting in the distilling flask used as a receiver. The above operation requires from five to ten hours.

This distillate is now treated with enough sodium hydroxide so that the mixture is left just faintly acid and the furfural separated. It amounts to 180 to 220 g. The wet furfural is distilled under diminished pressure from a Claisen flask which is heated in an oil-bath. The temperature of the bath is never permitted to rise above 130°. At first, water together with some furfural distils, and this fraction is separated to be worked up with a later portion. Finally, pure furfural (b. p. 90° at 65 mm.) distils and this fraction, collected separately, is found to be practically colorless. Its boiling point at 745 mm. is 159°. The distillation of the crude material must not be carried out under ordinary pressure, or else the product turns dark rapidly

\* A slight change in the method of collecting the furfural is described in *Org. Syn.* 6, 103.

on standing. After one vacuum distillation as described, however, a distillation under atmospheric pressure may be carried out without the objectionable results just mentioned.

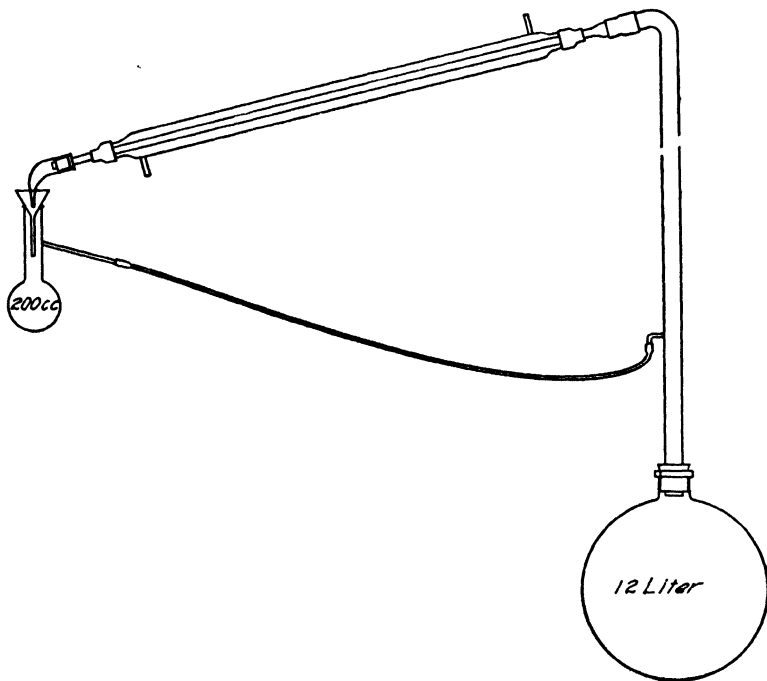

FIG. 4.

## 2. Notes

Vacuum distillation of the product is essential. Moreover in this final distillation the precautions mentioned (the use of an oil-bath and an outside temperature of less than  $130^{\circ}$ ) must be carefully observed. When the furfural is distilled under ordinary pressure or when it is distilled under diminished pressure with a free flame, a practically colorless product is at first obtained. After a few days and sometimes after a few hours this product will gradually darken until finally a black liquid results. This change, although most marked in the presence of light, takes

place readily even when the aldehyde is stored in brown-glass bottles. On the other hand, when the crude furfural is distilled under diminished pressure and is never heated above  $130^{\circ}$  during the process of distillation, a product is obtained that develops only a slight color when exposed to direct sunlight during several days. Further purification according to methods described in the literature does not give a product which will remain colorless on standing.

Certain samples of ground cobs which had remained in the laboratory for a year did not give nearly such good yields of furfural as those which were fresher.

The apparatus described (Fig. 4, p. 50) is a very convenient one for laboratory use but may be modified in many ways as long as a few essential points are kept in mind. A modification worth mentioning is the use as a receiver of a vessel the bottom of which has a stop-cock attached, thus allowing the furfural to be drawn off at any time. It is necessary to have the receiver several inches higher than the opening in the upright tube so that the aqueous liquors will flow back to the reaction flask; the lower end of the funnel in the receiver must be below the side arm of the receiver in order to prevent bubbles of furfural from collecting on the surface of the liquid and being carried back to the reaction flask; the entrance of the returning liquid into the upright tube must be at such a point that a vigorous stream of vapor passes through the returning liquid, thus extracting much of the furfural carried back in the water; the tube for returning the aqueous liquors must at some point be lower than the entrance to the upright tube so that a trap of liquid will be formed and prevent the vapors from the reaction flask entering the side tube. If the return tube is small and swings too low, it happens occasionally that a bubble of air gets into the tube and prevents the regular flow of liquid; this can be remedied by shaking the tube till the difficulty is overcome. It was found that the more efficient the upright tube was as a fractionating column, the more complete was the separation of furfural.

### 3. Other Methods of Preparation\*

Furfural occurs in many essential oils and is produced in small quantities in many organic reactions,<sup>1</sup> particularly those involving the decomposition of various carbohydrate materials. Pentoses when subjected to the action of hydrochloric acid are decomposed to give practically quantitative yields of this aldehyde.<sup>2</sup> It is well known that carbohydrate materials such as corn cobs, wood, bran, etc., when heated with steam under pressure or distilled with dilute hydrochloric or sulfuric acids, yield appreciable quantities of furfural.<sup>3</sup> Particularly good yields, however, are obtained from ordinary corn cobs, and this material therefore appears best for the production of large amounts of furfural in the laboratory. Improvements in the production of furfural from carbohydrate material have appeared recently in the patent literature<sup>4</sup> but those do not appear as satisfactory as the ones described.<sup>5</sup>

\* Recent methods of preparation through 1925 are described in *Org. Syn.* **6**, 106.

<sup>1</sup> E. Alderhalden's *Biochemisches Handlexicon* Vol. I (2), 853, gives an extensive review of the literature of furfural together with numerous references.

<sup>2</sup> *Am. Chem. J.* **13**, 73 (1891); *J. Anal. Appl. Chem.* **5**, 421 (1891); *Ber.* **24**, 3019 (1891).

<sup>3</sup> *Am. Chem. J.* **13**, 348 (1891); *Ann.* **74**, 280 (1850); **116**, 258 (1860); **156**, 197 (1870); **249**, 237 (1888); **260**, 291 (1890); *Ber.* **28**, 1940 (1888); *Am. Chem. J.* **3**, 33 (1881); "Organic Chemistry for the Laboratory" by W. A. Noyes (1920) p. 191; *J. Ind. Eng. Chem.* **13**, 133 (1921); *Z. angew. Chem.* **27**, 654 (1914).

<sup>4</sup> *C. A.* **13**, 1863 (1919).

<sup>5</sup> U. S. Patent Pending.

## XI

### MESITYL OXIDE

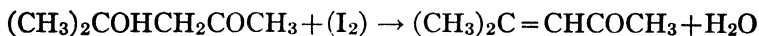

Prepared by J. B. CONANT and NEAL TUTTLE.  
Checked by ROGER ADAMS and H. C. N. HECKEL.

#### 1. Procedure

A 1-l. round-bottom flask is fitted with a three-bulb Glinsky fractionating column connected to a water-cooled condenser set for distillation. The crude diacetone alcohol prepared as previously directed (Exp. IX, p. 45) and 0.1 g. of iodine are placed in the flask. The crude alcohol will usually weigh about 1100 g. and will have a sp. gr. of about 0.91. The mixture is now distilled steadily but not too rapidly with a small free flame and three portions are collected as follows: I. 56–80°; II. 80–126°; III. 126–131°. The first portion is acetone containing a small amount of mesityl oxide and water; it can be used again for preparing more crude diacetone alcohol. The second portion separates into two layers,—water and crude mesityl oxide. The third portion is pure mesityl oxide. While the third fraction is distilling, the aqueous layer in fraction II is separated in a separatory funnel and the crude mesityl oxide is dried with anhydrous calcium chloride. This crude mesityl oxide is then distilled through a Glinsky column, and by this means a further amount of acetone and a small intermediate fraction (85–126°), which is best discarded, are separated. The pure mesityl oxide itself then distils between 126–130° and is added to the pure product already obtained as the third portion of the first distillation. The first complete distillation will require about five hours; the redistillation of portion III will

take about one hour. The yield is 650 g. (65 per cent of the theory based on the total acetone employed). About 300 g. of acetone are recovered.

## 2. Notes

The crude diacetone alcohol is prepared according to the directions in Exp. IX (p. 45). The acetone recovered from the preparation of mesityl oxide can be mixed with fresh acetone and successfully used in preparing more crude diacetone alcohol.

If the crude diacetone alcohol does not contain as much as 80 per cent of diacetone alcohol (if the refluxing is not carried out long enough, for example) the yield of mesityl oxide will be, of course, correspondingly low.

The first distillation should not be interrupted but should be carried out at a slow uniform rate until the distillation is complete.

The very last portion of fraction III is sometimes slightly colored, apparently by some iodine, which comes over at the end of the distillation. A small amount of high-boiling residue is always left.

## 3. Other Methods of Preparation

The methods of making mesityl oxide fall into three classes: (1) the action of condensing agents (hydrochloric acid, etc.) on acetone;<sup>1</sup> (2) the dehydration of diacetone alcohol;<sup>2</sup> (3) and from diacetoneamine.<sup>3</sup> The latter method was not considered since the amine is relatively difficult to prepare. The action of acid condensing agents on acetone is very unsatisfactory; the yields are poor and considerable quantities of phorone and similar substances are invariably produced. The direct production

<sup>1</sup> Am. Chem. J. **19**, 887 footnote (1897); Ann. **110**, 32 (1859); **178**, 343 (1875); **180**, 4 (1875); **188**, 131 (1877) J. Am. Chem. Soc. **35**, 1061 (1913); Compt. rend. **140**, 721 (1905); Ber. **41**, 574 (1908); Bull. soc. chim. (4) **3**, 829 (1908); for further references see Org. Syn. **6**, 107.

<sup>2</sup> Ann. **178**, 351 (1875); J. Am. Chem. Soc. **36**, 534 (1914); **37**, 1748 (1915); Monatsh. **34**, 779 (1913); Chem. Zentr. **80** (I), 1282 (1909); Frdl. **9**, 62 (1907-10); D. R. P. 208,635.

<sup>3</sup> Ber. **7**, 1387, 1777 (1874); Ann. **174**, 156 (1874).

of mesityl oxide from acetone and calcium oxide <sup>1</sup> was tried, but without success; diacetone alcohol was the principal product.

Several methods which have been proposed for the dehydration of diacetone alcohol were investigated. H. Hibbert's method <sup>2</sup> (using a very small quantity of iodine) is superior to either the action of concentrated sulfuric acid or aluminum phosphate. The reaction proceeds more easily and the product is purer; this method has therefore been adopted.

<sup>1</sup> J. Am. Chem. Soc. **31**, 722 (1909); Frdl. **11**, 46 (1912-14); D. R. P. 258,057.

<sup>2</sup> J. Am. Chem. Soc. **37**, 1748 (1915).



## XII

### METHYLENE IODIDE

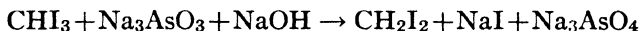

Prepared by ROGER ADAMS and C. S. MARVEL.

Checked by H. T. CLARKE and KATHARINE OGDEN.

#### 1. Procedure

IN a 5-l. round-bottom flask fitted with a rubber stopper holding a mechanical stirrer (Fig. 1, p. 4), a reflux condenser, a separatory funnel and a thermometer with bulb under the liquid, 1 kg. of iodoform is placed. To this are added 500 cc. of the sodium arsenite solution (prepared from 274 g. (1.5 mole) of arsenious oxide, 532 g. (7 moles) of sodium hydroxide and 2600 cc. of water). Stirring is started and heat is applied until the temperature of the thermometer reaches 60–65°, where it is held constant during the whole reaction. If the temperature is allowed to go much higher, especially at the beginning of the experiment, the reaction becomes too vigorous, and at the same time a little methyl iodide is formed. The remainder of the sodium arsenite solution is added gradually during the course of one-half an hour. The whole mixture is then kept one hour at 60–65° to be sure that the reaction is completed. The reaction mixture is allowed to cool somewhat (to about 40°) and is filtered with suction in order to remove the mechanical impurities which have come from the technical arsenious oxide and sodium hydroxide. The filtrate consists of a clear water solution with a pale yellow oil underneath. It is better not to allow the reaction mixture to cool completely before filtering or else a precipitate of sodium arsenate will gradually separate and this will tend to make an emulsion of the methylene iodide and hinder filtration and sep-

aration. The methylene iodide is now separated from the filtrate, is dried with a little calcium chloride and is distilled *in vacuo*. Practically all of it comes over as a light straw-colored oil between 106–107° at 70 mm., the bath being kept at 130–135°. The yield of crude product is 610 to 660 g. (90–97 per cent theory). By distillation, not more than 10 to 20 g. are lost. The crude product is quite satisfactory for most purposes. The methylene iodide obtained after distillation *in vacuo* melts at 6°.

## 2. Notes

Experiments were made on 100 g. lots of iodoform, using varying amounts (between 1 mole and 2 moles) of sodium arsenite. The yield is, in general, best when only a very slight excess over 1 mole of arsenious oxide is used. In every case the amount of sodium hydroxide employed was that called for by the theory.

The dilution of the solution makes very little difference, the yields remaining about the same. It is, therefore, better to use as concentrated a solution as possible so that large runs may be made in a comparatively small apparatus. A more concentrated solution, however, than the one advised above is not satisfactory, since too much sodium arsenate tends to separate out during the cooling after the methylene iodide has formed and causes some trouble in the purification. If sodium arsenate does separate, the methylene iodide is obtained either by distilling with steam, or by diluting and boiling to dissolve the crystals, this last to be followed by filtering and separating.

Mechanical stirring is quite necessary in order to get the best yields in the shortest time.

In making methylene iodide from 100 g. lots of iodoform or even 200 g. lots, the sodium arsenite solution may be added all at once. When the runs become larger, however, it is inadvisable to do this and directions similar to those described above in running a kg. of iodoform must be used.

After vacuum distillation, a residue of 1 to 2 g. is left in the flask. When air is admitted to the flask, a single flash of light sometimes occurs. In one case, the thermometer and stopper were even blown off the flask. The cause was not determined.

. If the reaction is carried out at refluxing temperature instead of at 60–65°, the yield of product is diminished by 5–10 per cent, the formation of a little methyl iodide accounting for the loss.

### 3. Other Methods of Preparation

Three common methods of production are described in the literature; the action of iodine,<sup>1</sup> sodium ethylate,<sup>2</sup> or hydriodic acid<sup>3</sup> on iodoform. The last of these three methods has been worked out in more detail and is the one generally recommended for the preparation of methylene iodide in the laboratory. In addition, methylene iodide has been produced by the action of iodine on diazomethane<sup>4</sup> and by electrolysis of iodoacetic acid.<sup>5</sup> It may also be made by the action of potassium iodide upon methylene chloride.<sup>5a</sup>

The reduction of iodoform by means of sodium arsenite,<sup>6</sup> described both by V. Auger and A. Gutmann, gave such successful results that the other methods were disregarded. The reaction is extremely simple and in the course of a few hours several pounds of pure methylene iodide may be prepared.

<sup>1</sup> Ann. **115**, 267 (1860).

<sup>2</sup> Ann. chim. phys. (3) **53**, 313 (1858).

<sup>3</sup> Z. Chem. **1868**, 712; Ber. **5**, 1095 (1872).

<sup>4</sup> Ber. **27**, 1889 (1894).

<sup>5</sup> Ber. **42**, 3869 (1909).

<sup>5a</sup> J. Chem. Soc. **119**, 1400 (1921).

<sup>6</sup> Compt. rend. **145**, 810 (1907); **146**, 1282 (1908); Ber. **52**, 212 (1919).



### XIII

#### METHYL HEXYL CARBINOL (CAPRYL ALCOHOL)

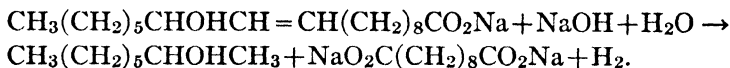

Prepared by ROGER ADAMS and C. S. MARVEL.  
Checked by OLIVER KAMM and W. S. MARLOTH.

#### 1. Procedure

For the most satisfactory preparation of methyl hexyl carbinol from castor oil, a copper vessel should be used. Since such a vessel is often not available in the average laboratory, directions are also included using an ordinary can, although in such cases the yields are much lower.

In a large dish pan, 1900 g. of No. AAA castor oil are treated with occasional stirring with a solution of 500 g. of technical (93-95 per cent) sodium hydroxide in 300 cc. of water. A reaction takes place, some heat is developed, and within ten or fifteen minutes a very hard solid soap is produced. This soap is broken up into small pieces and placed in a 3-gallon can. In this preparation, a petroleum ether can was used, but any kind available would be just as satisfactory. The container is now fitted with an efficient reflux condenser and it is then heated over a ring burner as long as hydrogen is given off. The heating is regulated to produce a fairly rapid evolution of gas as shown by leading a tube from the top of the condenser into a small beaker of water. The time required for the complete evolution of the hydrogen is about nine to ten hours.

If the above reaction is not completed at one time and intermediate cooling is allowed, the reaction mixture sets to a solid mass and certain precautions must be taken before proceeding farther. Either before heating is renewed, the mass must be

punched full of holes by means of an iron rod, or when the heating is started care must be taken to heat the upper part of the can first and gradually to approach the bottom. If the under part of the solid soap were heated directly, it would decompose before the upper part, and the hydrogen, being unable to escape, would cause the can to burst.

The condenser is now set downward for distillation and the heating is continued. If intermediate cooling is allowed, one of the precautions mentioned above before starting the distillation, must be observed. The alcohol distils over with the water and is separated from time to time, the water being returned to the distillation can by means of a separatory funnel inserted through a rubber stopper in the top of the can. The addition of this water must be very slow in order to prevent foaming. The heating should be regulated so that the distillate is coming over in rapid drops, not in a stream. If desired, the same sort of gravity separator described below under the large-sized experiment may be used in this small run. About twelve hours are required for this distillation. Toward the end, high-boiling products are obtained and considerable gas is liberated. Difficulty is almost always encountered during this part of the preparation since the long heating causes the solder in the bottom edge of the can to melt and leaks thus develop which allow a certain amount of soap to run out. The distillation need not be stopped, because the soap fills the holes, but under these conditions the temperature cannot be maintained at a point high enough for the complete distillation without material loss from increased leakage. The upper layer of crude alcohol is separated from the water and fractionated. The portion boiling from 100–120° is chiefly water with a little alcohol in it. The second fraction between 120–175° contains a considerable quantity of ketones along with the alcohol. The main portion 175–185°, is the methyl hexyl carbinol. Upon refractionation, 190 to 200 g. (23–25 per cent theory) of alcohol boiling at 175–180° are obtained.

This product is satisfactory for most purposes. If, however, a very pure product is desired, this may be made by shaking carefully the alcohol with 15 per cent sodium bisulfite solution,

separating the alcohol and steam distilling it from alkaline solution. The alcohol is finally distilled and the fraction boiling 177-179° is collected. If saturated sodium bisulfite be employed, a crystalline material which contains alcohol is formed and causes difficulty in the separation. Two runs of 6 kg. of castor oil with the same relative proportions of alkali and water were made in 8-gallon cans. The yield in the first case was 650 g. of pure material and in the second case 730 g.

#### PREPARATION IN COPPER VESSEL

To the cover of a 12-gallon copper kettle is fitted an apparatus to which a continuous separator may be attached (Fig. 5, p. 64). This apparatus consists of an upright water condenser through the jacket of which steam is passed; a connecting tube leads from the top of this condenser to a second spiral condenser the bottom of which extends into a gravity separator. This allows the alcohol to run off into a receiver and the heavier aqueous layer to return through a separatory funnel to the copper kettle. A few essential points in the apparatus should be indicated; it is necessary that the return arm of the gravity separator be below the tube through which the alcohol flows into the receiver; the lower end of the funnel must be below the return side-arm in order to prevent water being carried along with the methyl hexyl carbinol; the capillaries A and B are necessary to prevent siphoning in the respective tubes. A soap is made as already described from 11.2 kg. of No. AAA castor oil and 2900 g. of sodium hydroxide in 5800 g. of water. This is broken up, placed in the kettle and gradually heated. Much gas is evolved and care should be taken not to lose alcohol, particularly at the beginning. The separator is not adjusted and the stopcock of the separatory funnel is kept closed until about 3000 cc. of distillate are collected; any small amount of alcohol is separated and the water discarded. The separator is now put in place to return the water to the kettle. The separatory funnel is allowed to fill with liquid and then the stopcock regulated so that the liquid flows back to the copper vessel as fast as it distils over. A

return tube similar to the one used in the apparatus for the preparation of anhydrous oxalic acid (Fig. 6, p. 68) may be used, but in making methyl hexyl carbinol the separatory funnel has the advantage that if foaming occurs in the reaction flask, further addition of water can be immediately and easily stopped.

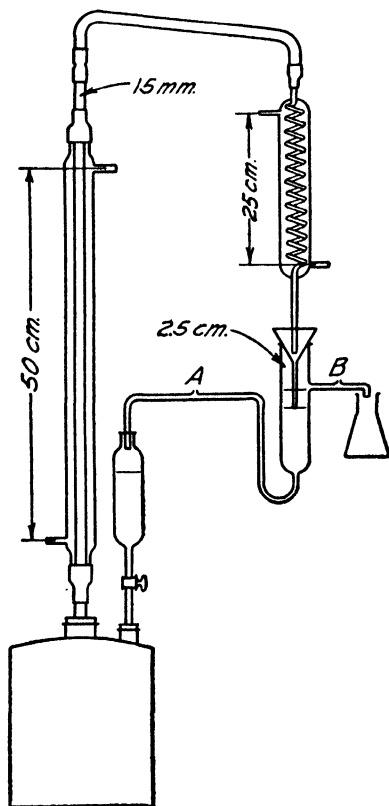

FIG. 5.

The distillation is continued until no more alcohol comes over, a process which requires forty-eight to seventy-two hours of continuous heating. Superheating must be avoided, since foaming will then occur and may cause considerable difficulty. It is therefore advisable to adjust the heating so that the distillate comes over in rapid drops but not in a stream. If cooling

is allowed to take place before the distillation is complete, it is advisable to break up the reaction cake before heating again, or to start the heating at the top of the cake and to approach the bottom gradually. The crude product obtained is very much lighter in color than that produced when cans are used, and when it is distilled only very small fractions of low or high boiling material result. Moreover, the amount of ketones is small. The yields of the redistilled fraction boiling at  $175-180^{\circ}$  in three successive experiments were 1854 g., 1955 g., and 1894 g. (39-41 per cent theory), quantities about twice those obtained when cans are used. The time that a man actually devotes to the production of methyl hexyl carbinol is not great, but the total time necessary for carrying out a large experiment is almost a week.

## 2. Notes

The best grade of castor oil gives much better results in this experiment than the poorer grades.

The container which is used in the production of methyl hexyl carbinol should not be filled more than half full of reaction mixture, since foaming occurs to a considerable extent during the heating.

The necessity of making holes in the solid soap or heating the top of the soap first, whenever cooling is allowed to take place during the initial heating or distillation is a precaution to which attention should again be drawn.

It is worthy of special note that the yield is much larger when the reaction is carried out in a copper vessel that is capable of being heated to a high temperature without leaking. An iron vessel cannot be substituted for copper. Several runs in iron gave about the same weight of crude product but this always contained high and low fractions that did not appear when copper was used.

Upon adding the water which distils over with the alcohol, to the reaction mixture, the special precaution must be taken of making the addition slowly or else the contact of the cold liquid

with the hot reaction mass causes very bad foaming. If the distillation is too rapid, superheating occurs and excessive foaming is liable to take place. After the methyl hexyl carbinol has all been distilled from the reaction mixture, the residue in the copper vessel should not be allowed to cool directly, as a solid cake that will have to be chiselled out will be formed. After the heating is stopped, it is advisable to add water to the hot residue, very slowly at first, then as the kettle cools, more rapidly. While still fairly hot, however, the mixture is poured into a crock and allowed to cool.

It is probable that stirring during the decomposition of the soap would increase the speed of the reaction and decrease the by-products.

It will be noticed that 5800 g. of water are used in the large runs and then 3000 g. are distilled off and discarded before the alcohol begins to come over rapidly. This quantity of water helps in the formation of the soap, but it is not absolutely necessary; only 2000 or 2500 g. may be used, under which conditions the alcohol begins to come over immediately with the water.

### 3. Other Methods of Preparation

Methyl hexyl carbinol may be made in a pure state by the action of methyl magnesium iodide upon heptaldehyde,<sup>1</sup> but it is more easily and cheaply obtained in a state of satisfactory purity for most purposes by the heating of castor oil with sodium hydroxide.<sup>2</sup> This gives sodium ricinoleate which upon fusion with caustic soda yields methyl hexyl carbinol. Other methods of theoretical interest have also appeared: the product may be prepared by the chlorination and subsequent hydrolysis of petroleum octane;<sup>3</sup> by the distillation of certain rarer oils with sodium hydroxide.<sup>4</sup>

<sup>1</sup> C. A. **11**, 3027 (1917).

<sup>2</sup> C. A. **11**, 3027 (1917); Ann. **87**, 111 (1853); **97**, 34 (1856); **147**, 222 (1868); J. prakt. Chem. **72**, 241 (1857); Ber. **24**, 3351 (1891).

<sup>3</sup> Ann. **152**, 152 (1869).

<sup>4</sup> Z. Chem. **1869**, 185.

## XIV

### OXALIC ACID (ANHYDROUS)<sup>1</sup>

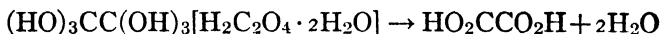

Prepared by H. T. CLARKE and ANNE W. DAVIS.  
Checked by ROGER ADAMS and V. VOORHEES.

#### 1. Procedure

IN a 5-l. round-bottom flask are placed 2 kg. of pure crystallized oxalic acid which has been passed through a 10-mesh sieve, and 3 l. of carbon tetrachloride. The flask is then fitted up with a mechanical stirrer and the apparatus shown in Fig. 6 (p. 68). This apparatus consists of an upright water condenser through the jacket of which steam is passed. A connecting tube leads from the top of this condenser to the top of a second efficient spiral condenser, the bottom of which extends into a gravity separator. The water runs off into a receiver and the heavier carbon tetrachloride layer returns to the reaction flask. A few essential points in the apparatus should be mentioned: it is necessary that the return arm of the gravity separator be below the tube through which the water flows into the receiver; the bottom of the funnel should be below the water outlet out as in the diagram; the openings A and B are necessary to prevent siphoning in the respective tubes; the last bend in the return tube before entering the reaction flask serves as a trap to prevent vapors from entering that tube.

The flask is placed up to its neck in hot water, stirring is started and the steam is allowed to flow through the first upright condenser. The heating of the flask and vigorous stirring is continued until no more water passes through into the condenser. This point is indicated by the fact that no more water flows from

the side-arm of the separator. A slight milkiness in the carbon tetrachloride, which persists even when practically no more water comes over, need not be considered. The time of heating depends to a large extent on the rate with which the vapors are

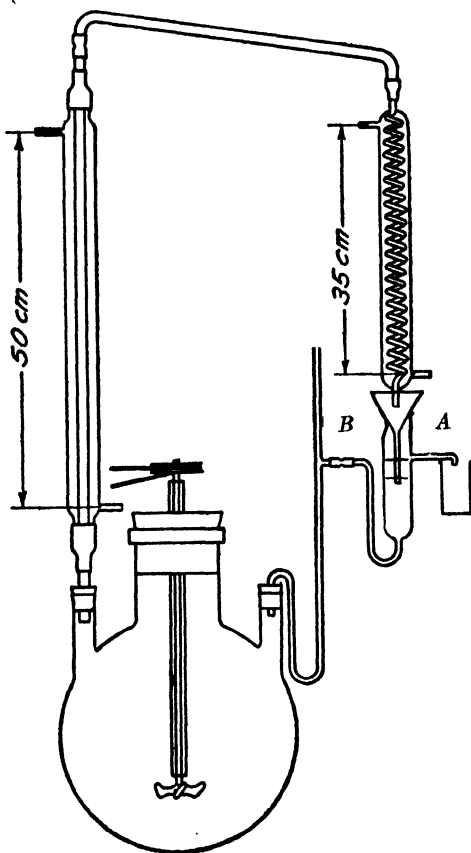

FIG. 6.

distilled over, and this rate in turn depends largely on the efficiency of the condenser. With an ordinary apparatus, such as that described, the time necessary will be approximately eighteen to twenty-four hours. The reaction mixture is now filtered with suction, care being taken that any oxalic acid which

is crusted above the surface of the carbon tetrachloride is not removed with the main portion of the product. The carbon tetrachloride may be used over again for another run, and the anhydrous oxalic acid is dried by short exposure to a warm dry atmosphere. The yield of product amounts to over 90 per cent of the theory.

## 2. Notes

As the time necessary for the dehydration depends almost entirely on the rate of boiling, care must be taken to select an efficient condenser. If a long spiral condenser is not available, a very successful device is to join the top of the upright tube to an ordinary long condenser placed in a slanting position, with its lower end connected by a bent tube of rather large bore to another condenser also in a slanting position, and leading back to the top of the gravity separator, the arrangement being > shape.

The heat may be applied to the flask either by direct flame, water bath, or steam bath.

It is well to place as much liquid in the flask as consistent with rapid boiling, since a slight crust of partially dehydrated acid is apt to collect around the upper edges of the carbon tetrachloride; this stays behind when the anhydrous acid is filtered off, and must not be included in the main product. Complete immersion of the flask in hot water will greatly minimize this trouble, and it is therefore recommended.

Carbon tetrachloride is in every way the most suitable liquid. It is not inflammable; the boiling temperature is such that water is readily evolved but sublimation of anhydrous acid is slight; and as the density is near to that of oxalic acid, an efficient mixing can be obtained. In benzene, the first and third conditions are not fulfilled; in toluene, none of them, for although the water is more rapidly driven off than with carbon tetrachloride the sublimation is so great as to be troublesome, and owing to the less efficient stirring in the liquid of lower density, the acid shows a great tendency to clump.

The stopper should be of good cork, covered if desired with

tin foil. Rubber stoppers are rapidly attacked by the carbon tetrachloride vapors and rendered useless after one run.

The carbon tetrachloride may be used over again in subsequent runs. A considerable portion of carbon tetrachloride is lost in the experiment, and this is the chief disadvantage in the procedure. It is almost impossible to filter the oxalic acid and recover more than about 80 per cent of the carbon tetrachloride. About 18 per cent remains attached to the anhydrous oxalic acid and evaporates when the oxalic acid is dried. The last 2 per cent is lost by evaporation during the dehydration.

### 3. Other Methods of Preparation

Oxalic acid can be dehydrated by heating to about  $100^{\circ}$  in an oven<sup>1</sup> or in an oil bath at  $145-150^{\circ}$ <sup>2</sup> but considerable loss occurs through sublimation; this is, moreover, harmful to the oven. This difficulty can be avoided by heating the crystallized acid at about  $60^{\circ}$  under reduced pressure,<sup>3</sup> removing the evolved water by passing the vapor through a condenser. This method is very slow and it is necessary to interrupt the process at frequent intervals and pulverize the mass which tends to clump and then refuses to lose water. Another method recommended involves treatment with concentrated sulfuric acid;<sup>4</sup> a preliminary trial proved it to be difficult to obtain even a reasonably good yield by this method, while the separation of adhering sulfuric acid offered many difficulties. The method<sup>5</sup> of dehydrating by means of carbon tetrachloride is quite satisfactory for the laboratory.

<sup>1</sup> Bull. soc. chim. (2) **33**, 415 (1880).

<sup>2</sup> Bull. soc. chim. (2) **38**, 406 (1882).

<sup>3</sup> Proc. Chem. Soc. **8**, 186 (1892).

<sup>4</sup> Jahresb. **1864**, 371; Ann. chim. (6) **19**, 58 (1890); Bull. soc. chim. (2) **38**, 406 (1882); Proc. Chem. Soc. **8**, 186 (1892).

<sup>5</sup> J. Am. Chem. Soc. **43**, 366 (1921).

## XV

### THIOPHENOL

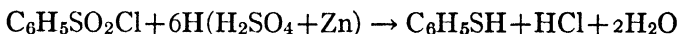

Prepared by ROGER ADAMS and C. S. MARVEL.

Checked by H. T. CLARKE and KATHARINE OGDEN.

#### 1. Procedure

IN a 12-l. round-bottom flask are placed 7200 g. of cracked ice and 2400 g. of concentrated sulfuric acid (sp. gr. 1.84). The mixture becomes very cold and is kept at  $-5^\circ$  to  $0^\circ$  by means of an ice-salt bath. Mechanical stirring is started and 600 g. of crude benzene sulfonyl chloride as prepared in Exp. III (p. 21) are gradually introduced (one-half an hour). Then 1200 g. of zinc dust (90 per cent) are added in portions as rapidly as possible without allowing the temperature to rise above that mentioned (this requires about one-half an hour). The contents of the flask are stirred for one to one and a half hours longer, the temperature being kept at  $0^\circ$  or below during the whole period. A stopper holding an efficient reflux condenser (lower end not constricted) and stirrer (Fig. 1, p. 4) is now attached, the ice bath is removed, and the reaction mixture is allowed to warm up spontaneously or it may be warmed up with a low flame, the stirring being continued. Within a very few (two to five) minutes, in many runs, a rather vigorous reaction with the evolution of much hydrogen takes place. Under these circumstances it is advisable to cool the flask momentarily by a stream of water. The reflux condenser will generally take care of the vapors satisfactorily, however. After the first ebullition has subsided, no further attention is required and the mixture is heated to boiling over a ring burner until the solution becomes clear. The stirring should be

continued during the refluxing and the stirrer should be arranged so as to suck the liquid downward from the surface. This helps distribute the zinc which holds hydrogen and floats on top of the liquid. About four to seven hours are required for the heating. The thiophenol is then distilled with steam, this process requiring about one hour. The product is separated from the water, dried with calcium chloride (shaking with calcium chloride for three to five minutes is generally sufficient) and distilled. The crude material weighs 359 g. (96 per cent theory) and the pure substance boiling 166–169° (71° at 15 mm.) 340 g. (91 per cent theory). For the whole experiment up to the final distillation ten to twelve hours are required.

## 2. Notes

The directions given in the literature advise the addition of the zinc dust to the sulfuric acid and then the benzene sulfonyl chloride. This procedure has been reversed in the way described above so that the minimum amount of hydrogen will be lost during the addition of the zinc.

It is essential that the temperature during the first part of the reaction be kept at 0° or below for otherwise poor yields are obtained.

Since benzene sulfonyl chloride solidifies at 15°, it is necessary to add it to the sulfuric acid slowly, with stirring, so that it will be as finely divided as possible when the zinc is added.

In order to hold the temperature at 0°, it is absolutely essential to add the zinc dust at least as slowly as described.

After the initial reaction at a low temperature had taken place, it was, in several instances, found convenient to allow the reaction mixture to stand overnight before proceeding further. The flask was thus left in the ice, which gradually melted allowing the reaction mixture to warm up to room temperature. Under these conditions, however, a poor yield generally resulted. Upon closer study, it was discovered that the small amount of product obtained was due to the sudden vigorous reaction, with consequent loss through the condenser, which took place when a

certain temperature was reached. The reaction mixture may be safely allowed to stand only if a very efficient condenser is used. In the checking of this experiment by Clarke and Ogden, no sudden reaction was observed and heating with a small flame after the initial mixing and stirring at  $0^{\circ}$ , gave excellent results. The difference in the experiments may have been due to a slightly different grade of raw materials.

Vigorous stirring while the reaction mixture is heated, cuts down materially the time of the reduction (from twelve to seven hours or less), as it brings the zinc which otherwise floats, into intimate contact with the acid and organic sulfur compound.

### 3. Other Methods of Preparation

Thiophenols have been produced by the action of sulfur on benzene in the presence of anhydrous aluminum chloride;<sup>1</sup> by the action of phosphorus pentasulfide on phenol;<sup>2</sup> of zinc on a mixture of sulfur chloride and benzene;<sup>3</sup> of sulfur chloride on benzene in the presence of anhydrous aluminum chloride;<sup>4</sup> by the fusion of the sodium salt of benzene sulfonic acid and sodium sulfhydrate;<sup>5</sup> by the dry distillation of the sodium salt of benzene sulfonic acid.<sup>6</sup> These methods, however, in every case give impure products and in very small yields so that no study was made of them. There are two methods described which do give satisfactory results for thiophenols. The first is by the treatment of aryl diazonium chlorides with potassium ethyl xanthogenate to give aryl ethyl xanthogenates; these compounds upon heating with alkali give thiophenols.<sup>7</sup> The reaction is very general and by it a large number of thiophenols have been prepared. Many side reactions may take place, how-

<sup>1</sup> Ann. chim. (6) **14**, 437 (1888).

<sup>2</sup> Z. Chem. **3**, 194 (1867).

<sup>3</sup> Ber. **11**, 1173 (1878).

<sup>4</sup> Ann. chim. (6) **1**, 531 (1884).

<sup>5</sup> Ber. **17**, 2080 (1884).

<sup>6</sup> Ann. **149**, 248 (1869).

<sup>7</sup> D. R. P. 45,120; Winther Patente der Organischen Chemie **I**, 243; J. prakt. Chem. (2) **41**, 179 (1890); Gazz. chim. ital. **21**, I, 213 (1891).

ever, and care is necessary in the preparation; it is reported<sup>1</sup> that in a number of instances violent explosions occurred when the conditions were not correct. The method is certainly not as simple to carry out as the reduction of sulfonyl chlorides. It does not give as good yields nor as pure products as the latter method; moreover, extraction with ether and treatment with alcoholic potassium hydroxide are both necessary. The second satisfactory method is the reduction of sulfonyl chlorides by means of zinc dust and sulfuric acid,<sup>2</sup> as described by R. Otto and E. Bourgeois. It can be seen immediately that this method is not applicable to any compound which may contain groups likely to be reduced with zinc and sulfuric acid, as for example a nitro compound, and thus it is more limited in its use than the diazonium reaction. For many of the simpler thiophenols, however, such as thiophenol itself and thiocresol, the results are very satisfactory, since the raw materials are easy to make and clean products in good yields are easily obtained. This procedure in this case is preferable to the preparation through the amines.

<sup>1</sup> Ber. **28**, 3240 (1895).

<sup>2</sup> Ann. **119**, 142 (1861); Ber. **10**, 939 (1877); especially Ber. **28**, 2319 (1895); *Réc. trav. chim.* **18**, 433 (1899); Ber. **51**, 751 (1918).

## XVI

### TRIMETHYLAMINE

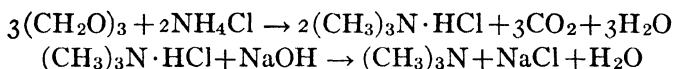

Prepared by ROGER ADAMS and B. K. BROWN.  
Checked by J. B. CONANT and A. MCB. KINNEY.

#### 1. Procedure

FIVE HUNDRED grams of technical ammonium chloride (2 moles) and 1330 g. of paraformaldehyde (corresponding to 9 moles of formaldehyde) are mixed together and allowed to react as described under Exp. XVII "Trimethylamine Hydrochloride" (p. 79). To obtain from this crude reaction-mixture a water or alcohol solution of trimethylamine, it is not satisfactory merely to treat with alkali and lead the trimethylamine through the solvent, since the gas is inefficiently absorbed; in fact, it is almost impossible to get a concentrated solution in this way without loss of material. The best way to prepare a solution is to liquefy the trimethylamine (b. p.  $3.5^\circ$ ) and in this form run it into the solvent. For this purpose, the 5-l. flask in which the initial reaction is carried out is fitted with a rubber stopper holding a separatory funnel and a glass tube for leading off the trimethylamine. This tube is run into one opening of a large U tube or Wolff bottle holding soda lime for drying the gas. The exit tube from this drying bottle has a glass tube leading to the top of an upright condenser which consists of a spiral tube cooled with a freezing mixture (Fig. 7, p. 76, see also Notes). The bottom of this condenser leads through a rubber stopper fitting tightly in a 2- or 3-l. flask, holding the solvent and im-

mersed in an ice-salt mixture. An exit tube from this flask leads to a Wolff bottle kept at a low temperature and holding a little solvent, and through this solvent any unabsorbed trimethylamine must bubble. The exit tube of this last Wolff bottle is closed with a soda lime tube if an anhydrous solvent is being used.

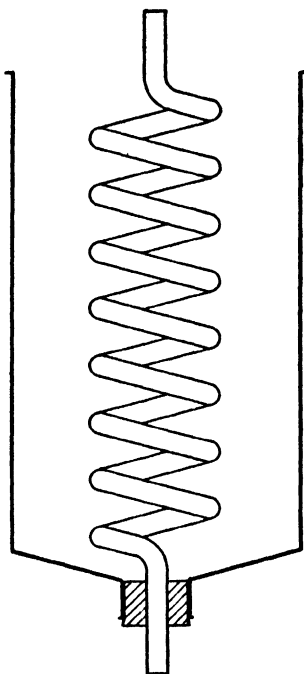

FIG. 7.

The separatory funnel is filled with sodium hydroxide solution (1100 g. in 2000 cc. of water) which is then allowed to flow into the reaction mixture at such a speed that after the air in the apparatus has been replaced by trimethylamine, a continuous stream of drops of trimethylamine flows from the condenser into the solvent and practically no gas goes through the end Wolff bottle. At the beginning, the evolution of trimethylamine is rapid and hence the addition of the alkali must be very slow; as soon as the reaction mixture is partly decomposed,

however, the alkali may be added more rapidly. After it has all been added, the reaction mixture is heated ten to fifteen minutes to make sure that all of the amine is evolved. The time for this alkali treatment is about three to four hours.

With such an experiment as is described above, using 1000 g. of absolute alcohol in the solvent flask and about 150 g. in the end Wolff bottle, 1469 g. of solution are obtained in the main flask and 174 g. in the Wolff bottle, thus indicating that a total of 491 g. (89 per cent theory) of trimethylamine are present. There is thus obtained a 32 per cent solution in the main flask which has a sp. gr. of about 0.760 at  $+5^{\circ}$ . By titration with standard hydrochloric acid, the same amounts of trimethylamine are indicated, as are found by weighing. In several experiments, the yields were consistently 85-90 per cent of the theory.

## 2. Notes

As trimethylamine is very volatile and easily lost, particular care must be taken to have all connections in the apparatus tight.

If water is to be used as a solvent, no soda lime tube is necessary on the exit of the end Wolff bottle. Moreover, with water as a solvent it is not absolutely necessary to have the soda-lime tube between the generating flask and the solvent. It is advisable to have it there, however, since it tends to catch any small amount of colored liquid coming from the reaction flask and thus prevents contamination of the water solution obtained.

During the evolution of the trimethylamine, it is necessary occasionally to shake the flask containing the solvent. It happens that after about a 10-15 per cent solution is formed, the trimethylamine tends to form a top layer which is not dissolved until agitated.

Titration of the strength of the trimethylamine in the solvent is best done by pipetting out 1 cc. of the solution and allowing it to run immediately into 50 cc. of water. This is to prevent volatilization during titration. The amine is then titrated in the usual way with standard hydrochloric acid, using methyl orange as an indicator.

In order to avoid loss of material, the sp. gr. of any trimethylamine solution must be taken at a low temperature. In this experiment,  $+5^{\circ}$  was chosen.

Since tests in the following experiment indicate that only trimethylamine is formed in this reaction, it is unnecessary to purify the trimethylamine solution.

Special attention should be drawn to the condenser (Fig. 7, p. 76) used since it is valuable in many other experiments wherever substances having a boiling-point between  $-10^{\circ}$  and  $+30^{\circ}$  are being handled. Any gallon can, having an opening in the top in which a stopper may be inserted, is satisfactory for a jacket. The bottom of the can is cut out and the can is then inverted. A spiral tube such as that which may be obtained from the inside of a spiral condenser is placed in the can with the lower end fitting tightly through the stopper in the neck. By filling the can with an ice and salt mixture a condensing temperature of  $-10^{\circ}$  or below can easily be obtained.

### 3. Other Methods of Preparation

The references to the preparation of trimethylamine are referred to in the following experiment entitled "Trimethylamine Hydrochloride."

## XVII

### TRIMETHYLAMINE HYDROCHLORIDE



Prepared by ROGER ADAMS and C. S. MARVEL.

Checked by J. B. CONANT and A. MCB. KINNEY.

#### 1. Procedure

FIVE HUNDRED grams of technical ammonium chloride (2 moles) and 1330 g. of paraformaldehyde (corresponding to a fraction over 9 moles of formaldehyde) are thoroughly mixed and placed in a 5-l. round-bottom flask fitted with a long reflux condenser (a jacket of about 100 cm. length and an inner tube of about 2 cm. diameter). By means of an oil bath, the temperature of the reaction mixture is gradually raised. Between 85° and 105° liquefaction at the bottom of the flask begins to take place and at the same time a very vigorous evolution of carbon dioxide starts. The heat is at once withdrawn and if the reaction is too violent, the oil bath should be removed. The reaction is allowed to continue without further heating until the gas evolution is less vigorous. This requires about one and a half hours. Heat is again applied and the temperature of the bath raised to about 160°, where it is held until there is practically no more evolution of carbon dioxide. This takes two and a half to three and a half hours, after which time the reaction is complete. To obtain the trimethylamine hydrochloride, it is now merely necessary to treat the mixture with sodium hydroxide, and to distil the free amine into hydrochloric acid. A separatory funnel is therefore inserted through the stopper of the flask and the reflux condenser is changed to a downward position for distillation. The open end of the condenser is fitted tightly into the neck of a boiling flask or suction flask, to the outside arm of

which is attached by means of rubber tubing, a glass tube which leads under hydrochloric acid in a receiver. Care must be taken to have all the joints in the apparatus tight as the trimethylamine is very volatile and can easily be lost. The object of the intermediate boiling or suction flask is to catch any water which may distil with the trimethylamine during the treatment with the sodium hydroxide. This water is often colored yellow, and if allowed to go directly into the hydrochloric acid in the receiver contaminates the trimethylamine hydrochloride. A solution of 1100 g. of sodium hydroxide (two and a half to three times the amount theoretically necessary to liberate the free amine) in 2000 cc. of water is allowed to drop through the separatory funnel into the reaction mixture, which has cooled somewhat during the change of apparatus. The amine distils, passes through the condenser, through the intermediate bottle and into the receiver, in which is placed an amount of concentrated hydrochloric acid (930 cc. of sp. gr. 1.19) slightly more than enough to neutralize the weight of amine which should theoretically be formed. To be certain that all the amine has been driven from the reaction flask, heat is finally applied for ten or fifteen minutes to the mixture. The whole procedure from the beginning of the first reaction until a solution of trimethylamine hydrochloride is obtained, requires not more than six to seven hours.

To obtain the trimethylamine hydrochloride, the hydrochloric acid solution is evaporated, first over a free flame and later, when the crystals start to form, on a steam bath. As the solution gets more and more concentrated, the trimethylamine hydrochloride crystallizes out and is filtered from time to time, is dried for a few minutes in an air bath, temperature 100–110°, and is finally kept in a tightly closed bottle. If the trimethylamine hydrochloride as it crystallizes is centrifuged, the product is obtained pure and dry at once. The average yield from four runs is 710 g. of perfectly pure trimethylamine hydrochloride and 82 g. of product which is tinged slightly yellow (a total of 89 per cent theory based on the ammonium chloride). This coloration results from the evaporation to dryness of the very last portion of solution.

## 2. Notes

The reaction takes place with the evolution of a considerable amount of heat and consequently a condenser as efficient as that mentioned is necessary in order to avoid loss. The wide inner tube is used to avoid any possibility of paraformaldehyde subliming and plugging the condenser.

The complete solubility of the product in chloroform<sup>1</sup> shows the trimethylamine hydrochloride to be free from ammonium chloride and methylamine hydrochloride and the fact that no precipitate is obtained when tested with sodium hydroxide and benzene sulfonyl chloride in aqueous solution shows that dimethylamine hydrochloride is absent.

## 3. Other Methods of Preparation

It is reported that trimethylamine in combination occurs in large amounts in beet-root residues<sup>2</sup> and can be obtained from them by the action of caustic soda; it occurs also in herring brine.<sup>3</sup> From both of these sources, however, the substance is obtained in an impure state and can be purified only by rather tedious methods. This is indicated by the fact that trimethylamine has always been an expensive substance. Synthetic methods for its production are by the action of methyl iodide on ammonia;<sup>4</sup> by the distillation of tetramethylammonium hydroxide;<sup>5</sup> by the action of magnesium nitride upon methyl alcohol;<sup>6</sup> by the action of zinc upon trimethyloxyammonium halides;<sup>7</sup> by the action of formaldehyde upon ammonium chloride under pressure;<sup>8</sup> by the action of ammonium chloride upon paraformaldehyde.<sup>9</sup> Of these syn-

<sup>1</sup> Compt. rend. **150**, 1251 (1910).

<sup>2</sup> Bull. soc. chim. (1) **27**, 150 (1877); Ber. **13**, 1669 (1880).

<sup>3</sup> Ann. **93**, 321 (1855).

<sup>4</sup> Ann. **79**, 16 (1851).

<sup>5</sup> Ann. **267**, 263 (1892).

<sup>6</sup> Ber. **30**, 306 (1897).

<sup>7</sup> Ber. **31**, 2064 (1898).

<sup>8</sup> Ber. **38**, 882 (1905); Bull. soc. chim. (3) **13**, 536 (1895).

<sup>9</sup> D. R. P. 270,260; Frdl. **11**, 111 (1912-14).

thetic methods the only ones which are cheap enough for the production of trimethylamine in large amounts are the last two. The action of ammonium chloride upon formaldehyde, however, must be carried out in autoclaves and at best only very small amounts of trimethylamine can be prepared in a reasonable time. The paraformaldehyde-ammonium chloride method developed by R. H. Schmitz runs very smoothly and gives an exceptionally pure product. This method, was, therefore, the only one investigated.

Since the appearance of Vol. I of Organic Syntheses, a new method described by Sommelet and Farrand by allowing ammonia, formaldehyde and formic acid to react has appeared in the literature.<sup>1</sup> The method has been checked by one of the editors and is highly recommended.

Other literature references may be found in Org. Syn. **6**, 108.

<sup>1</sup> Bull. soc. chim. (4) **35**, 446 (1924).

# INDEX

---

## A

Acetone, 45-47, 53, 54  
 Acrolein, 15, 18  
 Alkyl bromides, 1-13  
 Alkylene bromides, 1, 8, 9  
 Allyl alcohol, 3, 11, 15-19  
 Allyl bromide, 1, 3, 11, 17  
 Ammonium chloride, 75, 79, 81  
*iso*-Amyl alcohol, 4, 10  
*iso*-Amyl bromide, 1, 2, 4-5, 10

## B

Barium hydroxide, 45, 46  
 Benzaldehyde, 33  
 Benzene sulfonyl chloride, 21-23, 71, 72, 81  
 Benzil, 25-27, 29, 30  
 Benzilic acid, 29-32  
 Benzoic acid, 30  
 Benzoin, 25, 26, 33-34  
 Bromine, 2, 3, 35, 39  
 $\alpha$ -Bromonaphthalene, 35-37  
*o*-Bromophenol, 40, 41  
*p*-Bromophenol, 39-43  
*n*-Butyl alcohol, 5, 6  
*n*-Butyl bromide, 2, 5-6, 10

## C

Capryl alcohol. (See Methyl hexyl carbinol.)  
 Carbon tetrachloride, 17, 67-70  
 Carbon disulfide, 39, 41  
 Castor oil, 61, 63, 65  
 Chorobenzene, 21  
 Chloroform, 81  
 Corn cobs, 49, 51

## D

Diacetone alcohol, 45-47, 53, 54  
 1, 4-Dibromonaphthalene, 35, 36  
 2, 4-Dibromophenol, 40  
 Dimethylamine hydrochloride, 81

## E

Ethyl alcohol, 6, 29, 33  
 Ethyl bromide, 1, 6-7

## F

Fehling's solution, 26  
 Formic acid, 15-18  
 Furfural, 49-52

## G

Glycerol, 15, 17

## H

Hydrobromic acid, 1, 2-3, 4-11, 36, 39

## I

Iodine, 53, 54  
 Iodoform, 57, 58

## L

Lauryl alcohol, 7  
 Lauryl bromide, 7

## M

Mesityl oxide, 53-55  
 Methylamine hydrochloride, 81  
 Methylene iodide, 57-59  
 Methyl hexyl carbinol, 61-66  
 Methyl iodide, 57, 59

## N

Naphthalene, 35, 36

Nitric acid, 25, 26

## O

*n*-Octyl alcohol, 7*n*-Octyl bromide, 7

Oxalic acid, 17, 18

Oxalic acid (anhydrous), 18, **67-70**

## P

Paraformaldehyde, 75, 79, 81

Phenol, 39

Phosphorus oxychloride, 22

Phosphorus pentachloride, 21, 22

Potassium hydroxide, 29

Propylene bromide, 3, 11

## S

Sodium arsenite, 57, 58

Sodium benzene sulfonate, 21, 22

Sodium bisulfite, 62, 63

Sodium bromide, 2, 6, 8, 10

Sodium cyanide, 33

Sodium hydroxide 61, 63, 76

Sulfuric acid 49, 71

## T

Tartaric acid, 46

Thiophenol, **71-74**Trimethylamine, **75-78**Trimethylamine hydrochloride, 75, **79-82**

Trimethylene bromide, 2, 8, 10, 11

Trimethylene bromohydrin, 11

Trimethylene glycol, 8

## Z

Zinc dust, 71, 72













