

UNIVERSAL  
LIBRARY

**OU\_166871**

UNIVERSAL  
LIBRARY



OSMANIA UNIVERSITY LIBRARY

Call No. 681.414  
S89M

Accession No. 4800

Author Strandberg, M. W. P.

Title Microwave Spectroscopy. 19

This book should be returned on or before the  
last marked below.



METHUEN'S  
MONOGRAPHS ON  
PHYSICAL SUBJECTS

---

*General Editor:* B. L. WORSNOP, B.SC., PH.D.

MICROWAVE  
SPECTROSCOPY



# Microwave Spectroscopy

---

M. W. P. STRANDBERG

*Associate Professor of Physics,  
Massachusetts Institute of Technology*

WITH A PLATE & 14 DIAGRAMS

LONDON: METHUEN & CO. LTD.  
NEW YORK: JOHN WILEY & SONS, INC.

*First published in 1954*

CATALOGUE NO. 4057/U (METHUEN)

PRINTED IN GREAT BRITAIN AT THE PITMAN PRESS, BATH

## P R E F A C E

MICROWAVE spectroscopy began vigorous life in the post-1945 years, as a result of war-time technical advances. It rapidly proved to be a powerful instrument for both physical and chemical research. Experimental advances have caused the portion of the electro-magnetic spectrum embraced by the term microwave now to be generally considered that radiation having a wavelength from a few millimetres to a few tens of centimetres. The relevant detailed theory necessary to discuss microwave absorption phenomena had been established previous to the development of the experimental apparatus. Further necessary advances in the form of detailed application of quantum theory have been made, e.g., in the field of nuclear quadrupole effects and the Zeeman effect, so that microwave spectroscopy to-day is firmly established in both experimental and theoretical techniques.

The following discussion was undertaken by the author to make conveniently available the relevant information used to obtain and interpret microwave spectroscopic data. The emphasis has been on presenting a compact, unified treatment of the field. The treatment presupposes some familiarity with modern quantum mechanics and matrix methods. This background is readily accessible in the texts discussed in the bibliography.

The process of becoming acquainted with the material in this book may be considered several ways. It will put within the grasp of someone interested in working in the field the necessary fundamental tools. These tools are then conveniently extended either through investigation of specialized original sources or through a course of supplementary lectures. Alternatively, the material may be considered a second course in quantum theory whose framework consists of the many problems which may be precisely illustrated experimentally by microwave spectroscopic methods.

The text begins with a calculation of the quantum energy levels of a rotating molecule, and considers the various perturbations which may or must be recognized to interpret precise experimental data. The final sections deal with the instrumentation necessary to measure the frequencies in the microwave region which are characteristic of differences between these energy levels. With the resolution that microwave spectroscopy affords these frequencies are unique with each molecule. Furthermore by inverting the process, the molecular parameters which are used in the theory may be derived from a sufficient number of energy level differences or absorption frequencies. The study of these rotational levels and their measurement includes the bulk of the microwave spectroscopic material and hence they are treated to the exclusion of the also interesting electronic hyperfine structure which may come within the scope of microwave experimentation. Although microwave studies of paramagnetic materials are also justifiably termed microwave spectroscopy, they too have been omitted.

In short the material presented here, which should cover the bulk of present-day interest in microwave spectroscopy, should be qualified by the phrase "of rotating molecules." The whole field of microwave physics should be treated elsewhere in a text which even as of now would be several times the size of the present one.

# CONTENTS

CHAP.	PAGE
PREFACE	v
I. BACKGROUND MATERIAL	1
<i>A.</i> The General Hamiltonian	1
<i>B.</i> Properties of Momentum	2
II. CHARACTERISTIC ENERGIES OF FREE ROTATION	5
III. VIBRATION ROTATION INTERACTION	19
IV. NUCLEAR QUADRUPOLE ENERGY	30
V. STARK EFFECT	45
VI. ZEEMAN EFFECT	54
VII. INTERACTION OF ROTATIONAL AND ELECTRONIC STATES	62
VIII. LINE SHAPES AND INTENSITIES	64
IX. UNIQUE MICROWAVE TRANSITIONS	75
<i>A.</i> Oxygen	75
<i>B.</i> Ammonia	80
X. EXPERIMENTAL CONSIDERATIONS	87
XI. SOURCES OF RADIATION	93
XII. SAMPLE CELL	95
XIII. DETECTORS	100
XIV. ELECTRONIC APPARATUS	102
BIBLIOGRAPHY	113
Appendix I. TABLE OF REDUCED ENERGY	116
Appendix II. LINE STRENGTHS	122
Appendix III. ROTATIONAL MAGNETIC MOMENT MATRIX ELEMENTS	137
INDEX	139



## CHAPTER I

### BACKGROUND MATERIAL

#### *A. The General Hamiltonian*

THE basic problem of determining quantum mechanically the characteristic energies of a rotating molecule is one of expressing the Hamiltonian in terms of relevant co-ordinates and their conjugate momenta. The classical Hamiltonian for a general polyatomic molecule may be written formally as a sum of terms:

$$\begin{aligned} \mathbf{H} = & \mathbf{H}_n + \mathbf{H}_e + \mathbf{H}_v + \mathbf{H}_i + \mathbf{H}_r + \mathbf{H}_t + \mathbf{H}_{re} + \mathbf{H}_{rn} \\ & + \mathbf{H}_{rv} + \mathbf{H}_{ri} + \mathbf{H}_{rt} + \mathbf{H}' + \mathbf{H}_{\text{stark}} + \mathbf{H}_{\text{mag}} \quad (\text{I.1}) \end{aligned}$$

Such a description of the Hamiltonian in terms of separate nuclear, electronic, vibrational, inversion, rotational, and translational energy and their mutual interaction contributions may seem inappropriate at first sight. However, the description, based on the Born-Oppenheimer approximation, is adequate when the symbols are properly interpreted. We consider the construction of a molecule. The act of assembling individual nucleons into a nucleus has associated with it an energy  $\mathbf{H}_n$ . The addition of electrons to create a molecule adds a term  $\mathbf{H}_e$ . The nuclei may vibrate in this molecule giving rise to a term  $\mathbf{H}_v$ ; the inversion energy, if such a possibility exists, is described by  $\mathbf{H}_i$ . The molecule, as a whole, is allowed to rotate, and the pure rotational Hamiltonian  $\mathbf{H}_r$  is added. Finally, the existence of translational energy is accounted for by  $\mathbf{H}_t$ . New correction terms must be added to account for the difference between the nuclear, electronic, vibrational, and inversion energies as described by  $\mathbf{H}_n$ ,  $\mathbf{H}_e$ ,  $\mathbf{H}_v$ ,  $\mathbf{H}_i$ , and  $\mathbf{H}_t$  and the actual energy in the presence of rotation. Terms expressing the modification of  $\mathbf{H}_n$  due to  $\mathbf{H}_e$  and so forth, which will not

concern us since they are constant and small perturbations, we lump in  $H'$ . Finally, the possible presence of electric and magnetic fields, applied at will in the laboratory, is accounted for by  $H_{\text{stark}}$  and  $H_{\text{mag}}$  which describe the interaction energy of such fields with the molecular charges and currents.

The main objective of this monograph is to study concisely the allowed quantum mechanical states, or energies, that arise from the rotational term  $H_r$ . Successively, the modifications necessary to accommodate the interaction terms will be considered. The specific forms of these terms will be considered when they are studied later in detail. We consider that the ground states of the terms  $H_n$ ,  $H_e$ ,  $H_v$ , and  $H_i$  have been successively determined and proceed to the free rotation problem.

### B. Properties of Momentum

We may express  $H_r$  in the usual way in terms of the components of the momentum on the principal inertial axes of the molecule.

$$H_r = \sum_g P_g^2 / 2I_g; \quad g = x, y, z \text{ (principal axes)} \quad . \quad (\text{I.2})$$

The stationary energy states of a free molecule are thus determined by the quantum mechanical properties of the components of the angular momentum.

The algebra of non-commuting vectors is well known, so we review only briefly these properties. The commutation relations for the matrices of the components of the total angular momentum of a system resolved along molecule-fixed axes are written as:

$$\begin{aligned} P_x P_y - P_y P_x &= -i\hbar P_z \\ P_y P_z - P_z P_y &= -i\hbar P_x \\ P_z P_x - P_x P_z &= i\hbar P_y \end{aligned} \quad (\text{I.3})$$

Identical commutation relations with the sign of  $i$  changed apply for the components of the angular momentum along space-fixed axes (X, Y, Z = F). In a representation in which  $P^2 = P_x^2 + P_y^2 + P_z^2 = P_X^2 + P_Y^2 + P_Z^2 = J(J+1)\hbar^2$  and  $P_x$  and  $P_z$  are simultaneously diagonal (i.e. equal to



The results may be factored into J, K, and M dependent terms in this fashion:

$$(J, K, M | \Phi_{F_{\theta}} | J', K', M') \\ - (J | \Phi_{F_{\theta}} | J') \cdot (J, K | \Phi_{F_{\theta}} | J', K') \cdot (J, M | \Phi_{F_{\theta}} | J', M') \quad (I.6)$$

Thus the direction cosine matrix elements may be displayed in the form given in Table 1.

TABLE 1. Direction cosine matrix elements

Matrix Element Factor	Value of $J'$		
	$J + 1$	$J$	$J - 1$
$(J   \Phi_{F_{\theta}}   J')$	$\{4(J + 1)(2J + 1) \\ (2J + 3)\}^{-1/2}$	$[4J(J + 1)]^{-1}$	$[4J(4J^2 - 1)]^{-1/2}$
$(J, K   \Phi_{F_{\theta}}   J', K)$	$2[(J + 1)^2 - K^2]^{1/2}$	$2K$	$2(J^2 - K^2)^{1/2}$
$(J, K   \Phi_{F_{\theta}}   J', K \pm 1) \\ - + i(J, K   \Phi_{F_{\theta}}   J', K \pm 1)$	$\mp [(J \pm K + 1) \\ (J \pm K + 2)]^{1/2}$	$[J(J + 1) \\ - K(K + 1)]^{1/2}$	$\pm [(J \mp K) \\ (J \mp K - 1)]^{1/2}$
$(J, M   \Phi_{F_{\theta}}   J', M)$	$2[(J + 1)^2 - M^2]^{1/2}$	$2M$	$2(J^2 - M^2)^{1/2}$
$(J, M   \Phi_{F_{\theta}}   J', M \pm 1) \\ - \pm i(J, M   \Phi_{F_{\theta}}   J', M \pm 1)$	$\pm [(J \pm M + 1) \\ (J + M + 2)]^{1/2}$	$[J(J + 1) \\ - M(M \pm 1)]^{1/2}$	$\pm [(J \mp M) \\ (J \mp M - 1)]^{1/2}$

These expressions for the components of momentum and their transformation properties form the foundation upon which the following discussions will depend. They are hastily sketched, since their application rather than their derivation is the object of this book. They should be well understood, however, so that the succeeding work will be intelligible.

## CHAPTER II

### CHARACTERISTIC ENERGIES OF FREE ROTATION

SINCE the free rotational energy, given in Chapter I, equation (I.2), depends only upon  $P_y^2$ , the squares of the matrices for  $P_x$ ,  $P_y$ , and  $P_z$  must be formed. If  $n$  and  $m$  signify the totality of quantum or state numbers we have by matrix multiplication:

$$(n|P_y^2|m) = \sum_l (n|P_y|l)(l|P_y|m)$$

Since only  $(J, K, M|J, K, M)$  or  $(J, K, M|J, K \pm 1, M)$  elements exist for  $P_y$  then  $P_y^2$  can have only  $(J, K, M|J, K, M)$  elements (when  $n = l = m$ ) and  $(J, K, M|J, K \pm 2, M)$  elements (when  $l = J, K \pm 1, M$  and  $m = J, K \pm 2, M$ ). The non-vanishing matrix elements of  $P_y^2$  are thus found to be:

$$\begin{aligned} (J, K, M|P_y^2|J, K \pm 2, M) &= \dots (J, K, M|P_x^2|J, K \pm 2, M) \\ &= \frac{\hbar^2}{4} \{J(J+1) - K(K \pm 1)\} \\ &\quad \{J(J \mp 1) - (K \pm 1)(K \pm 2)\}^{\frac{1}{2}} \end{aligned}$$

$$\begin{aligned} (J, K, M|P_y^2|J, K, M) &= (J, K, M|P_x^2|J, K, M) \\ &= \frac{\hbar^2}{2} [J(J+1) - K^2] \end{aligned}$$

$$(J, K, M|P_z^2|J, K, M) = \hbar^2 K^2 \quad \dots \quad \dots \quad \dots \quad (II.1)$$

The characteristic energy matrix,  $W_r$ , may then be obtained by writing equation (I.2), in Chapter I, page 2, in terms of these angular momentum matrices. The energy is diagonal in  $J$  and  $M$ , so for a given value of  $J$  and  $M$ , the rotational energy matrix elements may be written:

$$(J, K|W_r|J, K) = \frac{\hbar^2}{4} \left\{ \frac{2}{I_z} - \frac{1}{I_y} - \frac{1}{I_x} \right\} K^2 + \frac{\hbar^2}{4} \left( \frac{1}{I_y} + \frac{1}{I_x} \right) J(J+1)$$

$$(J, K | W_r | J, K \pm 2) = \frac{h^2}{8} \{ [J(J+1) - K(K \pm 1)] \\ [J(J+1) - (K \pm 1)(K \pm 2)] \}^{\frac{1}{2}} \left( \frac{1}{I_y} - \frac{1}{I_x} \right)$$

For reasons either immediately obvious, or soon to become apparent, it is convenient to introduce at this point a series of changes in variables. To apply the foregoing results to any particular molecule the gyrating  $z$ -axis, along which we have chosen to represent the  $K$  momentum, may be associated with any of the three principal axes of inertia of the molecule. If the principal axes are labelled  $a$ ,  $b$ , and  $c$  such that  $I_a \leq I_b < I_c$ , then three right-handed associations of axes may be made: (1) with  $K$  along the axis of least inertia, so that  $z \rightarrow a$ ,  $x \rightarrow b$ ,  $y \rightarrow c$ ; (2) with  $K$  along the axis of intermediate moment of inertia, so the  $z \rightarrow b$ ,  $x \rightarrow c$ ,  $y \rightarrow a$ ; or (3) with  $K$  along the axis of greatest moment of inertia so that  $z \rightarrow c$ ,  $x \rightarrow a$ ,  $y \rightarrow b$ . It is evident that for the present all of these representations are equally useful, though later discussions will indicate the factors which, for reasons of simplicity, indicate the particular representation to be used in the solution of a given problem.

Now define reciprocal moments of inertia such that

$$a = \frac{h}{8\pi^2 I_a} \text{ c.p.s., etc.}$$

Further define an asymmetry factor  $\kappa$  such that

$$\kappa = \frac{2b - a - c}{a - c}$$

In terms of these definitions the rotational energy matrix elements for the three equivalent right-handed representations become:

$$(1) (J, K | W_r | J, K) = \frac{a + c}{2} J(J+1)h \\ + \frac{a - c}{2} \left\{ \frac{1}{2}(\kappa + 1)[J(J+1) - K^2] + K^2 \right\} h$$

$$(J, K|W_r|J, K \pm 2) = \frac{a}{8} \frac{c}{h} (\kappa \pm 1) \{ [J(J+1) - K(K \pm 1)] [J(J+1) - (K \pm 1)(K \pm 2)] \}^{\frac{1}{2}} h$$

$$(II) (J, K|W_r|J, K) = \frac{a}{2} \frac{c}{h} J(J+1)h + \frac{a}{2} \frac{c}{h} \kappa K^2 h$$

$$(J, K|W_r|J, K \pm 2) = \frac{a}{4} \frac{c}{h} \{ [J(J+1) - K(K \pm 1)] [J(J+1) - (K \pm 1)(K \pm 2)] \}^{\frac{1}{2}} h$$

$$(III) (J, K|W_r|J, K) = \frac{a}{2} \frac{c}{h} J(J+1)h + \frac{a}{2} \frac{c}{h} \{ \frac{1}{2} (\kappa \pm 1) [J(J+1) - K^2] - K^2 \} h$$

$$(J, K|W_r|J, K \pm 2) = \frac{a}{8} \frac{c}{h} (\kappa \pm 1) \{ [J(J+1) - K(K \pm 1)] [J(J+1) - (K \pm 1)(K \pm 2)] \}^{\frac{1}{2}} h \quad (II.2)$$

These three forms of the characteristic rotational energy may be further factored to good purpose into the form:

$$W_r = \frac{a}{2} \frac{c}{h} J(J+1)h + \frac{a}{2} \frac{c}{h} E(\kappa)h \quad (II.3)$$

where, in general, the matrix elements of the reduced energy,  $E(\kappa)$ , are given as:

$$(J, K|F(\kappa)|J, K) = F[J(J+1) - K^2] + GK^2$$

$$(J, K|E(\kappa)|J, K \pm 2) = \frac{H}{2} \{ [J(J+1) - K(K \pm 1)] [J(J+1) - (K \pm 1)(K \pm 2)] \}^{\frac{1}{2}} \quad (II.4)$$



matrix, i.e.,  $|E^J(\kappa) - \delta_{KK'}\lambda| = 0$ , where  $\delta_{KK'} = 1$  when  $K = K'$  and  $\delta_{KK'} = 0$  when  $K \neq K'$ . Since the  $E^J(\kappa)$  matrix (and hence the secular determinant) is of order  $2J + 1$ , there will be  $2J + 1$  roots or characteristic values. As a book-keeping procedure we shall label each root by a number  $\tau$  such that  $J \geq \tau \geq -J$  and such that the magnitude of  $\tau$  decreases with decreasing characteristic value. In short any general characteristic value of the reduced energy matrix will be given as  $E_\tau^J(\kappa)$ . Since the only off diagonal matrix elements are off the diagonal by an even number ( $\pm 2$ ), the  $E(\kappa)$  matrix may be factored further into four submatrices by the Wang symmetrizing transformation  $X$ ,

$$X = X^{-1} = \frac{1}{\sqrt{2}} \begin{bmatrix} \cdot & & & & & & & & \cdot \\ & \cdot & & & & & & & & \cdot \\ & & \cdot & & & & & & & & \cdot \\ & & & \cdot & & & & & & & & \cdot \\ & & & & -1 & & 1 & & & & & & \cdot \\ & & & & & -1 & & 1 & & & & & & \cdot \\ & & & & & & \sqrt{2} & & & & & & & & \cdot \\ & & & & & & & 1 & & 1 & & & & & & \cdot \\ & & & & & & & & 1 & & & 1 & & & & & \cdot \\ & & & & & & & & & & \cdot & & & & & & & \cdot \\ & & & & & & & & & & & & \cdot & & & & & & \cdot \\ & & & & & & & & & & & & & \cdot & & & & & & \cdot \\ & & & & & & & & & & & & & & \cdot & & & & & & \cdot \end{bmatrix} \quad (11.6)$$

when use is made of the relationships:

$$\begin{aligned} E_{K, K} &= E_{-K, -K} \\ E_{K, K+2} &= E_{K+2, K} = E_{-K, -K-2} \\ &= E_{-K-2, -K} \end{aligned}$$

The transformation  $X^{-1}EX$  essentially switches from an expansion in terms of function vectors  $|J, K, M\rangle$  to an expansion in terms of vectors  $|J, 0, M\rangle$  and  $2^{-\frac{1}{2}}[|J, |K|, M\rangle \pm |J, -|K|, M\rangle]$ , thus, with evident notation, these four submatrices may be written compactly as follows.

$$\begin{aligned}
 E_{E+}^J(\kappa) &= \begin{bmatrix} E_{00} & \sqrt{2}E_{02} & 0 & \cdot & \cdot & \cdot \\ \sqrt{2}E_{02} & E_{22} & E_{21} & 0 & \cdot & \cdot \\ 0 & E_{21} & E_{41} & \cdot & \cdot & \cdot \\ \cdot & \cdot & \cdot & \cdot & \cdot & \cdot \\ \cdot & \cdot & \cdot & \cdot & \cdot & \cdot \end{bmatrix} \\
 E_{E-}^J(\kappa) &= \begin{bmatrix} E_{22} & E_{21} & 0 & \cdot & \cdot & \cdot \\ E_{21} & E_{44} & E_{46} & 0 & \cdot & \cdot \\ 0 & E_{46} & E_{66} & E_{68} & \cdot & \cdot \\ \cdot & \cdot & \cdot & \cdot & \cdot & \cdot \\ \cdot & \cdot & \cdot & \cdot & \cdot & \cdot \end{bmatrix} \\
 E_{0+}^J(\kappa) &= \begin{bmatrix} E_{11} + E_{-11} & E_{13} & 0 & \cdot & \cdot & \cdot \\ E_{13} & E_{33} & E_{35} & \cdot & \cdot & \cdot \\ 0 & E_{35} & E_{55} & E_{57} & \cdot & \cdot \\ \cdot & \cdot & \cdot & \cdot & \cdot & \cdot \\ \cdot & \cdot & \cdot & \cdot & \cdot & \cdot \end{bmatrix} \\
 E_{0-}^J(\kappa) &= \begin{bmatrix} E_{11} - E_{-11} & E_{13} & 0 & \cdot & \cdot & \cdot \\ E_{13} & E_{33} & E_{35} & \cdot & \cdot & \cdot \\ 0 & E_{35} & E_{55} & \cdot & \cdot & \cdot \\ \cdot & \cdot & \cdot & \cdot & \cdot & \cdot \\ \cdot & \cdot & \cdot & \cdot & \cdot & \cdot \end{bmatrix}
 \end{aligned}
 \tag{11.7}$$

Each of these sub-matrices  $E_{E_+^J}$ ,  $E_{E_-^J}$ ,  $E_{0_+^J}$ , and  $E_{0_-^J}$  is roughly the order of  $J/2$ , so that the solution of the secular determinant is considerably less onerous than might appear at first thought. For all the values of  $J$  less than or equal to three and for some states with  $J$  values of four or five the secular equation is quadratic, and hence the roots may be explicitly determined. For higher  $J$  values the continued fraction expansion of the roots may be fruitfully applied. Transform first to the unsymmetrical matrix

$$D = L^{-1} E^J L \quad L^{-1} \begin{bmatrix} k_0 & b_1^{\frac{1}{2}} & 0 & \cdot & \cdot & \cdot \\ b_1^{\frac{1}{2}} & k_1 & b_2^{\frac{1}{2}} & \cdot & \cdot & \cdot \\ 0 & b_2^{\frac{1}{2}} & k_3 & \cdot & \cdot & \cdot \\ \cdot & \cdot & \cdot & \cdot & \cdot & \cdot \\ & \cdot & \cdot & \cdot & \cdot & \cdot \\ & & \cdot & \cdot & \cdot & \cdot \end{bmatrix} L$$

$$D = \begin{bmatrix} k_0 & 1 & 0 & \cdot & \cdot & \cdot \\ b_1 & k_1 & 1 & \cdot & \cdot & \cdot \\ 0 & b_2 & k_2 & 1 & \cdot & \cdot \\ \cdot & \cdot & \cdot & \cdot & \cdot & \cdot \\ & \cdot & \cdot & \cdot & \cdot & \cdot \\ & & \cdot & \cdot & \cdot & \cdot \end{bmatrix}$$

where  $L = \begin{bmatrix} 1 & 0 & & & & \\ 0 & b_1^{-\frac{1}{2}} & 0 & & & \\ & 0 & b_1^{-\frac{1}{2}} b_2^{\frac{1}{2}} & 0 & & \\ & & 0 & b_2^{-\frac{1}{2}} b_3^{\frac{1}{2}} & & \\ & & & & & \end{bmatrix} \quad [l_{ii}]$

(11.8)



Divide the last row by  $k_n - \lambda_m$  and subtract from the next to the last row. This leaves the last column all zeros except for the term  $k_n - \lambda_m$ , which is non-zero and immediately factorable. Multiply the first row by  $b_1/(k_0 - \lambda_m)$  and subtract from the second row. This leaves the first column all zeros except for the term  $k_0 - \lambda_m$ , which is non-zero and immediately factorable. This determinant is given by (II.10).

The root is then evidently

$$\begin{array}{cccccccc}
 \lambda_m & k_m & & & & & & b_m \\
 & & k_{m-1} & \lambda_m & & & & b_{m-1} \\
 & & & & k_{m-2} & \lambda_m & & \dots \\
 & & & & & & b_{m+1} & \\
 & & & & & & & b_{m+2} \\
 & & k_{m+1} & \lambda_m & & & & k_{m+2} \\
 & & & & & & & \lambda_m \dots
 \end{array} \quad . \quad (II.11)$$

This expression is rapidly convergent, so that even  $k_m$  itself may be taken as a first guess to the root  $\lambda_m$ , to generate an improved value of the true root.

It may be noted that one root in a submatrix may be calculated by using the general property of invariance of the diagonal sum of a determinant under unitary transformation, i.e.,

$$\sum_n k_n = \sum_n \lambda_n \quad . \quad (II.12)$$

The transformation which diagonalizes the submatrix D, i.e., solves the secular determinant, may be readily determined from the eigen-values so determined. The state represented by the root  $\lambda_\tau$  may be determined by inspection from equation (II.9). The secular determinant may be written in terms of the amplitudes of states relative to the state with subscript 0, as:

$$\begin{array}{l}
 (k_0 - \lambda_\tau) a_{1\tau} = 0 \\
 b_1 + (k_1 - \lambda_\tau) a_{1\tau} + a_{2\tau} = 0 \\
 \dots \dots \dots = 0 \quad . \quad (II.13)
 \end{array}$$

The relative amplitude of state 1 is thus  $-(k_0 - \lambda_\tau)$ , while that of state 2 is given by the second line of equation (II.13) as

$(k_1 - \lambda_\tau)(k_0 - \lambda_\tau) = b_1$ . The general relative amplitudes are then simply given as:

$$\begin{aligned}
 a_{0\tau} &= 1 \\
 a_{1\tau} &= (k_0 - \lambda_\tau) \\
 a_{2\tau} &= (k_1 - \lambda_\tau)a_{1\tau} = b_1 \\
 &\dots \\
 a_{p\tau} &= (k_{p-1} - \lambda_\tau)a_{p-1,\tau} - b_{p-1}a_{p-2,\tau} \dots \quad (II.14)
 \end{aligned}$$

The matrix  $D(\kappa)$  is then diagonalized by the transformation  $\Lambda$  which is formed from these relative amplitudes as:

$$\Lambda = \begin{bmatrix} a_{0\tau} & a_{0\tau'} & a_{0\tau''} & \dots & \dots & \dots \\ a_{1\tau} & a_{1\tau'} & a_{1\tau''} & \dots & \dots & \dots \\ \dots & \dots & \dots & \dots & \dots & \dots \\ \dots & \dots & \dots & \dots & \dots & \dots \\ \dots & \dots & \dots & \dots & \dots & \dots \end{bmatrix} \quad (II.15)$$

Since  $\Lambda^{-1}D\Lambda = \Lambda$ , where  $\Lambda$  is a diagonal matrix formed by the roots

$$\Lambda = \begin{bmatrix} \lambda_\tau & & & & & \\ & \lambda_{\tau'} & & & & \\ & & \lambda_{\tau''} & & & \\ & & & \dots & & \\ & & & & \dots & \\ & & & & & \dots \end{bmatrix} \quad (II.16)$$

then by equation (II.8),

$$\Lambda^{-1}L^{-1}ELA = \Lambda \dots \dots \quad (II.17)$$

The transformation  $\Lambda A$  is not normalized as it must be to give a total state amplitude of 1. This is readily accomplished by the normalizing matrix  $N$ :



in Fig. 1. The symmetry about the dotted diagonal results, of course, from the relationship expressed in equation (II.20).

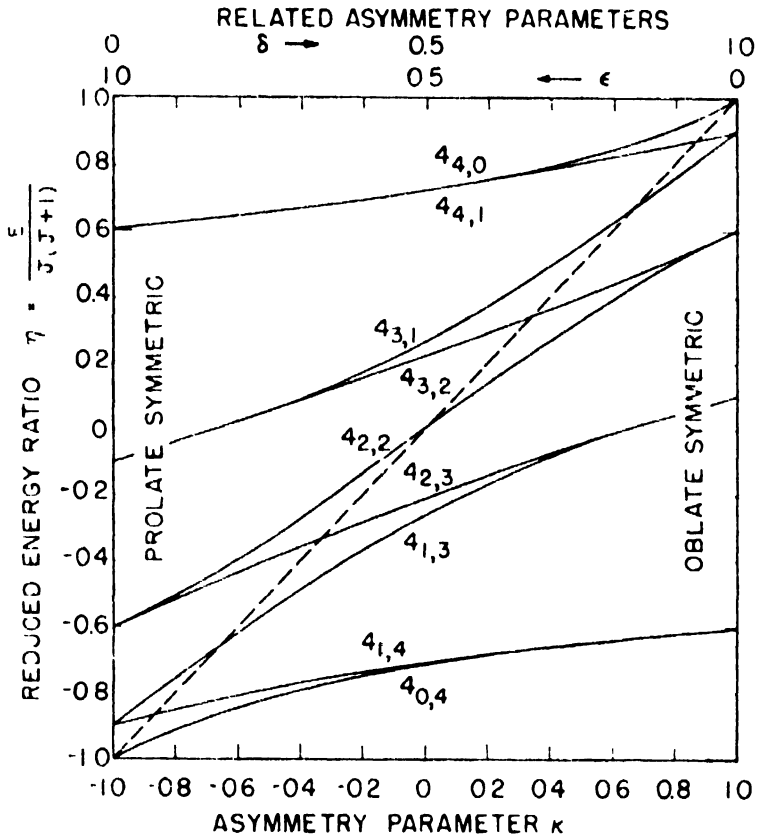

Fig. 1. Reduced energy variation with  $\kappa$  . . .

We note also that the total rotational energy for a given level  $J, \tau$  is

$$\begin{aligned}
 W_{\tau}^J &= \frac{a}{2} J(J+1)h + \frac{a}{2} E_{\tau}^J(\kappa)h \\
 &= \frac{2\pi}{h} [a \langle P_a^2 \rangle + b \langle P_b^2 \rangle + c \langle P_c^2 \rangle] = \frac{2\pi}{h} \sum_g \bar{g} \langle P_g^2 \rangle \quad (II.21)
 \end{aligned}$$

where  $\langle P_g^2 \rangle = (J, \tau, M | P_g^2 | J, \tau, M)$  is the value of the diagonal matrix element of the projection of  $P^2$  on the  $g$  axis. Hence to a first order

$$\frac{\partial W_{\tau}^J}{\partial \bar{g}} = \langle P_g^2 \rangle \frac{2\pi}{h} \quad (II.22)$$

Explicitly

$$\langle P_a^2 \rangle = \frac{\hbar^2}{2} [J(J+1) + E_\tau^J(\kappa) - (1+\kappa) \langle P_b^2 \rangle \hbar^{-2}]$$

$$\langle P_b^2 \rangle = \hbar^2 \frac{dE_\tau^J(\kappa)}{d\kappa}$$

$$\langle P_c^2 \rangle = [J(J+1)\hbar^2 - \langle P_a^2 \rangle - \langle P_b^2 \rangle] \quad (II.23)$$

Finally, the expression for the reduced energy may be simplified in the symmetric top limits. For a prolate top (like a pencil)  $b = a$  and  $\kappa = -1$ . The rotational energy is most conveniently determined in the (I) representation for then  $H = 0$  and  $E^J(\kappa)$  is immediately diagonal. This leads to the characteristic energy levels:

$$W_{|K|}^J = bJ(J+1)\hbar + (b-c)K^2\hbar \quad (II.24)$$

Each value of  $|K| > 0$  leads to a doubly degenerate energy since  $E_{0,+}^J$  and  $E_{0,-}^J$  are identical, and  $E_{|K|,+}^J$  and  $E_{|K|,-}^J$  are identical except for the single  $K = 0$  root.

Similarly for an oblate symmetric top (like a penny)  $b = c$  and  $\kappa = +1$ . The (III) representation yields a diagonal form for the reduced energy matrix. Thus the characteristic energy levels are given as:

$$W_J^J = bJ(J+1)\hbar + (b-a)K^2\hbar \quad (II.25)$$

Since the rotational energy decreases with increasing  $K$  we have used for  $\tau$  the value of  $J - |K|$ . As in the case of the prolate top each level for  $|K| > 0$  is doubly degenerate. Note, in general, that for a type (I) representation the highest value of  $|K|$  corresponds to the highest energy state, and hence, to the highest  $\tau$ . Conversely, for the type (III) representation, the lowest value of  $|K|$  corresponds to the highest value of  $\tau$ . Hence, if  $|K|$  in the (I) representation is labelled  $K(-1)$  (i.e., the  $K$  value of the symmetric top state with  $\kappa = -1$ ), and  $|K|$  in the (III) representation is labelled as  $K(+1)$  (i.e., the  $K$  value of the symmetric top state with  $\kappa = +1$ ) the highest state is  $E_{K(-1)=J, K(+1)=0}^J(\kappa) = E_\tau^J(\kappa)$ .

Since the  $K(-1) = 0$  is a singlet state and the  $K(-1) \neq 0$  is a doublet state, the next highest reduced energy, will be

$$E_{K(-1) = J, K(+1) = 1}^J(\kappa) = E_{\tau = J-1}^J(\kappa)$$

In general an  $E_{\tau}^J$  level may be labelled as  $E_{K(-1), K(+1)}^J$ , where

$$\begin{aligned} K(-1) - K(+1) &= \tau \\ K(-1) + K(+1) &= J, J \pm 1 \dots \end{aligned} \quad (II.26)$$

Hence, 
$$K_{+1} = \frac{J \pm \tau}{2} + \left\{ \begin{matrix} 0 \\ \frac{1}{2} \end{matrix} \right\} = 0, 1, 2, \dots$$

$$\tau = \mp \left[ J - 2K_{+1} + \left\{ \begin{matrix} 0 \\ 1 \end{matrix} \right\} \right] \quad (II.27)$$

This type of labelling is illustrated in Fig. 1, where the reduced energy has values of  $E_{+1,0}^J(\kappa) = E_{\tau=+1}^J(\kappa)$  down to  $E_{0,+1}^J(\kappa) = E_{\tau=-1}^J(\kappa)$ .

The linear rotor is the limiting form of the prolate symmetric top since  $c \rightarrow 0$ . Since angular momentum may exist along the  $c$  axis due to degenerate vibrational states, we shall call this angular momentum not  $K$  but  $l$ . Hence for a linear rotor

$$W_l^J = h[J(J+1) - l^2]/h, J \geq l \geq -J \quad (II.28)$$

## CHAPTER III

### VIBRATION-ROTATION INTERACTION; CENTRIFUGAL DISTORTION

WHEN the fact that the vibrational energy of a molecule may be disturbed by the presence of rotational energy is taken into account, and, reciprocally, that the vibrational energy may affect the rotational energy, additional correction terms must be included in the Hamiltonian. The correction terms arise from two causes. First, instantaneous angular momentum may be associated with vibrational states of the molecule. Hence, the angular momentum components measured along the gyrating molecule-fixed axes will instantaneously be the sum of the nuclear rotational angular momentum  $N_g$ , and the vibrational angular momentum  $p_g$ . Thus

$$P_g = N_g + p_g \text{ or } N_g = P_g - p_g$$

Second, this nuclear rotational angular momentum is to be associated with a moment of inertia which is now dependent upon the vibrational state, since the vibrational state determines the actual nuclear co-ordinates in terms of displacements from the nuclear co-ordinates in the absence of vibrational energy.

From these considerations then one would expect to write  $N_g$  to include these corrections as:

$$N_g = P_g - p_g = I_{gg}\omega_g + I_{gg'}\omega_{g'} + I_{gg''}\omega_{g''} \quad \text{(III.1)}$$

The terms involving the products of inertia  $I_{gg'}$ ,  $g \neq g'$  arise from the fact that the nuclear vibrations do not preserve the principal axes determined with the nuclei at rest. In short, the inertial constants will be given by their equilibrium values plus a correction depending upon the possible  $3n$  cartesian displacements. These are most conveniently written

in terms of the  $3n - 6$  (or  $3n - 5$  for linear molecules) normal vibration displacements  $Q$  and the masses of the  $n$  nuclei. If the  $g$  axis displacement of the  $i$ th nucleus of mass  $M_i$  is written as:

$$\delta g_i = M_i^{-\frac{1}{2}} \sum_s l_{is}^{(g)} Q_s$$

where twice the vibrational kinetic energy is  $\sum_s \dot{Q}_s^2$ . Then

$$I_{gg} = I_{gg}^e + \sum_s a_s^{(gg)} Q_s \\ + \sum_s \sum_{s''} [A_{ss''}^{(gg)} - \sum_{s'} \zeta_{ss'}^{(g)} \zeta_{s''s'}^{(g)}] Q_s Q_{s''}$$

$$I_{gg'} = - \sum_s a_s^{(gg')} Q_s \\ - \sum_s \sum_{s''} [A_{ss''}^{(gg')} - \sum_{s'} \zeta_{ss'}^{(g)} \zeta_{s''s'}^{(g')}] Q_s Q_{s''}$$

where as Nielsen has shown:

$$a_i^{(gg)} = 2 \sum_i M_i^{-\frac{1}{2}} (g_{0i}' l_{is}^{g'} g_{0i}'' l_{is}^{g''}) \\ a_s^{(gg')} = - \sum_i M_i^{-\frac{1}{2}} (g_{0i} l_{is}^{g'} g_{0i}' l_{is}^{g'}) \\ A_{ss''}^{(gg)} = \sum_i (l_{is}^{g'} l_{is''}^{g'} + l_{is}^{g''} l_{is''}^{g''}) \\ A_{ss''}^{(gg')} = - \sum_i l_{is}^{g'} l_{is''}^{g'} \\ \zeta_{ss'}^{(g)} = \sum_i (l_{is}^{g'} l_{is'}^{g''} - l_{is'}^{g'} l_{is}^{g''})$$

The existence of products of inertia means that angular frequencies must be given by inverting equation (III.1) as:

$$\omega_g = \sum \mu_{gg'} (P_g - p_g) \quad . \quad . \quad (III.2)$$

where

$$\mu_{gg'} = \mu^{-1} \frac{\partial \mu}{\partial I_{gg'}}$$

$\mu$  = determinant of  $I$ , the moment of inertia tensor.

The rotational energy in Hamiltonian form may then be written as:

$$H_r' = \frac{1}{2} \sum_g \sum_{g'} \mu_{gg'} (P_g - p_g) (P_{g'} - p_{g'}) \quad . \quad (III.3)$$

The  $\mu_{gg'}$  are now expanded in terms of the  $I_{gg'}^e$  and the normal co-ordinate correction terms. The  $P_g$ -dependent terms are given as:

$$\begin{aligned}
 H_r' &= \frac{1}{2} \sum_g \frac{P_g^2}{I_{gg}^c} - \sum_g p_g P_g \\
 &- \frac{1}{2} \sum_s \left\{ \sum_{g'} \sum_g P_{g'} \frac{(P_g - 2p_g)}{I_{gg}^c I_{g'g'}^c} a_s^{(gg')} \right\} Q_s \\
 &- \frac{1}{2} \sum_s \sum_{s'} Q_s Q_{s'} \left\{ \sum_g \sum_{g'} G_{ss'}^{gg'} \frac{P_g P_{g'}}{I_{gg}^c I_{g'g'}^c} \right\}
 \end{aligned} \tag{III.4}$$

where

$$G_{ss'}^{gg'} = A_{ss'}^{(gg')} - \sum_{s''} \zeta_{ss''}^{(g)} \zeta_{s's''}^{(g')} - \sum_{g''} \frac{a_s^{(gg'')}}{I_{g''g''}^c} a_{s'}^{(g''g')}$$

The last three terms in equation (III.4) form the correction terms to the rotational energy which arise from the interaction of rotational and vibrational energy-states. The first term on the right side of equation (III.4) forms the normal rotational energy which we have considered in the preceding chapter.

We now expand equation (III.4) in terms of familiar matrix elements. The  $P_g$ 's may be written in the representation of Chapter I. The  $p_g$ 's and  $Q$ 's may be expressed in terms of the matrix elements for the one-dimensional oscillator. The vibrational angular momentum  $p_g$  is related to the linear momentum of the harmonic modes as:

$$p_g = \sum_i \sum_s \sum_{s'} l_{is}^{g'} l_{is'}^{g''} \left[ \left( \frac{\lambda_{s'}}{\lambda_s} \right)^{\frac{1}{2}} q_s p_{s'} - \left( \frac{\lambda_s}{\lambda_{s'}} \right)^{\frac{1}{2}} q_{s'} p_s \right] \tag{III.5}$$

where now

$$Q_s = \left( \frac{\hbar^2}{\lambda_s} \right)^{\frac{1}{2}} q_s$$

$$\lambda_s = (2\pi c \tilde{\omega}_s)^2$$

From the commutation relations for the one dimensional oscillator,  $p_s q_s - q_s p_s = -i\hbar$ , we know that the matrix elements of  $p_s$  and  $q_s$  in terms of the vibrational quantum number  $v_s$  are as given on p. 22.

$$\begin{aligned}
 \langle v_s | q_s | v_s + 1 \rangle &= \frac{1}{2} [2v_s + 1 + 1]^{\frac{1}{2}} \\
 \langle v_s | p_s | v_s + 1 \rangle &= i \frac{\hbar}{2} [2v_s + 1 + 1]^{\frac{1}{2}} \quad . \quad (III.6)
 \end{aligned}$$

when the harmonic terms of the vibrational Hamiltonian,  $\frac{1}{2} \sum_s (\lambda_s Q_s^2 + \dot{Q}_s^2) = \frac{\hbar}{2} \sum_s (p_s^2 \hbar^{-2} + q_s^2) \lambda_s^{\frac{1}{2}}$ , are diagonal in  $v_s$ .

In case a degeneracy of normal modes exists due to geometrical symmetry of the molecule these matrix elements must be modified. For example, the linear molecule may have a two-fold degeneracy of modes oscillating perpendicular to the symmetry axis of the molecule. These modes are properly combined to have the matrix elements of the two-dimensional isotropic oscillator. Since the energies of the two degenerate modes are equal, one of the quantum numbers  $v_s$  becomes redundant and is replaced by a quantum number  $l_1 = v_s, v_s - 2, \dots, 1, \text{ or } 0$ , which measures the angular momentum along the symmetry axis created by the degeneracy. The actual matrix elements need not concern us directly except to note that if  $z$  is the figure axis  $p_z^2$  has diagonal elements equal to  $\hbar^2 l^2$ . Thus since  $P_x^2 + P_y^2 = \hbar^2 J(J + 1) - P_z^2$  then  $P_x^2 + P_y^2 = \hbar^2 [J(J + 1) - l^2]$ , yielding the form of equation (II.28), Chapter II.

The vibrational energy terms in the Hamiltonian are the harmonic kinetic and potential energy terms plus the anharmonic terms of higher order in the normal co-ordinate as:

$$\sum_s \sum_{s'} \sum_{s''} K_{ss's''} Q_s Q_{s'} Q_{s''} + \sum_{ss's''s'''} \dots \quad . \quad (III.7)$$

The matrix elements of the harmonic vibrational energy are diagonal in the vibrational quantum numbers and, of course, in the rotational quantum numbers, upon which they do not depend. They are just  $\hbar \lambda_s^{\frac{1}{2}} (v_s + \frac{1}{2})$ .

The matrix elements of the normal rotational energy  $\frac{1}{2} \sum_g \frac{P_g^2}{I_{gg}}$  are diagonal in the vibrational quantum numbers, and in  $J$  and  $M$  with the usual  $(K|K)$  diagonal elements and  $(K|K \pm 2)$  off diagonal elements.

The anharmonic vibrational term in equation (III.7) will have elements diagonal in the rotational quantum numbers and off diagonal elements in the vibrational quantum numbers.

Finally, the correction terms in equation (III.4) will have

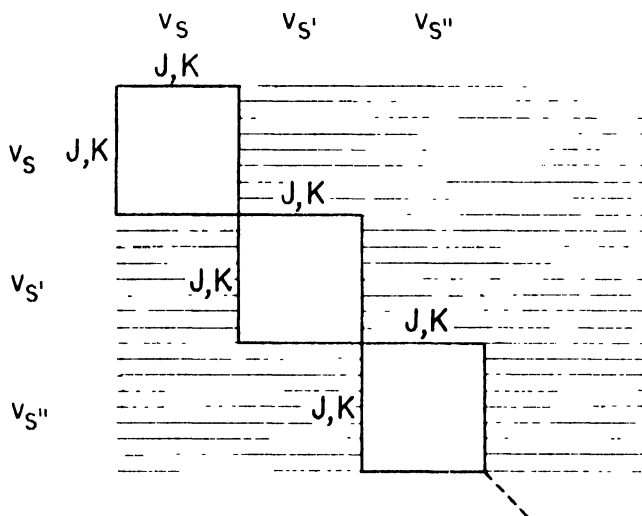

Fig. 2. Vibration-rotation energy matrix

elements non-diagonal in both vibrational and rotational quantum numbers.

Thus, if we construct the total energy matrix by forming rotational energy blocks for each vibrational state, it will have the appearance of Fig. 2.

There will be matrix elements connecting the rotational blocks of different vibrational states due to the correction terms in equations (III.4) and (III.7). The existence of these elements is indicated by the shading in Fig. 2.

The method of adding rows and columns used in Chapter II to reduce these off-diagonal terms to zero in the secular determinant formed from this matrix for a given rotational and vibrational state of energy  $W(v_s, J, K)$ , will result in the appearance in their place of terms in the correction Hamiltonian  $H'$  of the form

$$\frac{(v_s, J, K | H' | v_{s'}, J, K') (v_{s'}, J, K' | H' | v_{s''}, J, K'')}{(v_{s'}, J, K' | H | v_{s'}, J, K') - W(v_s, J, K)} \quad (III.8)$$

These are certainly negligibly small, since the vibrational energy differences are so great. There is the possibility that the vibrational states may be accidentally degenerate. This case has been investigated but does not change our following discussion.

The reduction of the terms off-diagonal in the vibrational quantum numbers leads to the addition of a term within a given rotational block  $v_s, J, K$  of the form,

$$\frac{(v_s, J, K | \mathbf{H}' | v_{s'}, J, K')(v_{s'}, J, K' | \mathbf{H}' | v_s, J, K'')}{(v_{s'}, J, K' | \mathbf{H} | v_{s'}, J, K') - W(v_s, J, K)} \quad (III.9)$$

Now the contribution of the rotational energy to the denominators of relation (III.9) is certainly negligible in the absence of vibrational degeneracy. Hence, the dependence of the denominators on the rotational state may be suppressed and the denominators may be written as:

$$(v_{s'}, J, K | \mathbf{H} | v_{s'}, J, K') - W(v_s, J, K) \simeq W(v_{s'}) - W(v_s) \quad (III.10)$$

The vibrational energy is only slightly perturbed from its harmonic value hence we may write  $W(v_s) \simeq h \sum_s \lambda_s^{\frac{1}{2}} (v_s + \frac{1}{2})$ . Thus within a given rotational block the rotational matrix elements may be written to first order in terms of the unperturbed Hamiltonian  $\mathbf{H}_r = \frac{1}{2} \sum \frac{P_g^2}{I_{gg}}$  and the perturbing Hamiltonian  $\mathbf{H}'$  which comprises the correction terms of equations (III.4) and (III.7) as

$$\begin{aligned} (v_s, J, K | \mathbf{H}_r' | v_s, J, K') &= (J, K | \mathbf{H}_r | J, K') \\ &+ \sum_{v_s} (v_s, J, K | \mathbf{H}' | v_s, J, K') \\ &+ \sum_{v_{s'}, K''} \frac{(v_s, J, K | \mathbf{H}' | v_{s'}, J, K'')(v_{s'}, J, K'' | \mathbf{H}' | v_s, J, K')}{W(v_s) - W(v_{s'})} \end{aligned} \quad (III.11)$$

The part of the matrix element of  $\mathbf{H}'$  which depends upon the rotational quantum numbers is due to the  $P_g$  terms only.

Hence, the equation (III.11) may be simplified in notation by writing it in the form:

$$\begin{aligned} \mathbf{H}_r'(v_s) = & \mathbf{H}_r + \frac{1}{2} \sum_{g, g'} \sigma_{gg'}(v_s) \mathbf{P}_g \mathbf{P}_{g'} \\ & + \frac{1}{4} \sum_{g, g', g'', g'''} \tau_{g, g', g'', g'''}(v_s) \mathbf{P}_g \mathbf{P}_{g'} \mathbf{P}_{g''} \mathbf{P}_{g'''} \end{aligned} \quad (\text{III.12})$$

where  $\sigma(v_s)$  and  $\tau(v_s)$  are constants for the molecule in vibrational state  $v_s$ . The form of equation (III.12) is achieved by realizing that the non-vanishing terms cubic in  $\mathbf{P}_g$ , such as  $\mathbf{P}_g^2 \mathbf{P}_{g'} - \mathbf{P}_{g'} \mathbf{P}_g^2$ , may be written in terms of quadratic factors by means of the commutation relations. Thus:

$$\mathbf{P}_g^2 \mathbf{P}_{g'} - \mathbf{P}_{g'} \mathbf{P}_g^2 = i\hbar(\mathbf{P}_g \mathbf{P}_{g''} + \mathbf{P}_{g''} \mathbf{P}_g) \quad . \quad (\text{III.13})$$

Equation (III.12) is still too general for practical use. Consider the terms in  $\sigma_{gg'}$ . If  $g \neq g'$  then these terms will have non-zero elements only of the type  $(K|K \pm 1)$  since  $\sigma_{gg'} = \sigma_{g'g}$ . If the symmetrizing transformation  $\mathbf{X}$  is applied to  $\mathbf{H}_r'$ , then  $\mathbf{H}_r$  is factored into blocks of odd and even  $K$ . Hence, the  $(K|K \pm 1)$  elements connect these blocks and can contribute only in second order. For similar reasons the  $\tau$ -dependent terms contribute in first order only if  $g = g'$  and  $g'' = g'''$ , or  $g = g'''$  and  $g' = g''$ , or  $g = g''$ ,  $g' = g'''$ . So to first order we rewrite equation (III.12) as:

$$\mathbf{H}_r'(v_s) = \mathbf{H}_r + \sum_g \sigma'_{gg} \mathbf{P}_g^2 + \frac{1}{2} \sum_{g, g'} \tau'_{ggg'g'} \mathbf{P}_g^2 \mathbf{P}_{g'}^2 \quad (\text{III.12a})$$

when use is made of the commutation relations and the fact that  $\tau_{ggg'g'} = \tau_{g'g'gg}$ ,  $\tau_{gg'g'g} = \tau_{g'g'gg}$ ,  $\tau_{g'ggg'} = \tau_{g'gg'g}$  to reduce term involving  $\mathbf{P}_g \mathbf{P}_{g'}^2 \mathbf{P}_g$  and  $(\mathbf{P}_g \mathbf{P}_{g'})^2$ . This involves redefining in a straightforward fashion the  $\sigma$ 's and  $\tau$ 's of equation (III.12), a fact which is indicated by the primes in equation (III.12a).

Equation (III.12a) is readily interpreted for we may achieve it by saying the vibrational average of the reciprocal moment of inertia is given as:

$$(\mathbf{I}_g^{-1})_{vr} = (\mathbf{I}_g^e)^{-1} + \sigma'_{gg}(v_s) + \sum_{g, g'} \tau'_{g'g'gg}(v_s) \mathbf{P}_{g'}^2 \quad . \quad (\text{III.14})$$



$$E_{0 \perp}^J(\kappa) = \begin{bmatrix} E_{11} \pm E_{1,-1} & E_{13} \pm E_{1,-3} & E_{15} & 0 & \cdot & \cdot & \cdot \\ E_{13} \pm E_{1,-3} & E_{33} & E_{35} & E_{37} & \cdot & \cdot & \cdot \\ E_{15} & E_{35} & E_{55} & E_{57} & \cdot & \cdot & \cdot \\ 0 & E_{37} & \cdot & \cdot & \cdot & \cdot & \cdot \\ \cdot & \cdot & \cdot & \cdot & \cdot & \cdot & \cdot \\ \cdot & \cdot & \cdot & \cdot & \cdot & \cdot & \cdot \end{bmatrix} \quad (III.17)$$

The continued fraction expansion is no longer as convenient to use because of the second off-diagonal elements in the factored forms, however, other methods are available to evaluate the distortion correction.

Since the correction term is small we are really only interested in the diagonal values of  $T^{-1}X^{-1}P_g^2P_g'^2XT$ , where  $T$  is the diagonalizing transformation of  $H_r(v)$ . The transformation  $T$  is readily evaluated by the usual methods. It is usually easier, however, to develop expressions for the fourth power of the angular momentum components in a form analogous to those obtained for the squares of the components in terms of the derivatives of the reduced energy with respect to  $\kappa$ .

Since under any transformation

$$P^2 = P_x^2 + P_y^2 + P_z^2 = \hbar^2 J(J + 1) \quad (III.18)$$

then when  $H_r(v)$  is diagonal with eigen values  $W$  we have:

$$\begin{aligned} \langle H_r(v) \rangle &= W = \frac{2\pi}{\hbar} \sum \bar{g} P_g^2 \\ &= \frac{2\pi}{\hbar} [(\bar{g} - \bar{g}')P_g^2 + (\bar{g}'' - \bar{g}')P_g'^2 + \bar{g}'J(J + 1)\hbar^2] \end{aligned} \quad (III.19)$$

and 
$$W^2 = \frac{(2\pi)^2}{\hbar^2} (\sum \bar{g} \langle P_g^2 \rangle)^2 \quad (III.20)$$

Since  $W^2$  is diagonal, in terms of the diagonal values of the momentum operators we have:

$$\begin{aligned} \frac{\partial W^2}{\partial \bar{g}} = & 2 \frac{(2\pi)^2}{\hbar^2} W \langle P_g^2 \rangle - \frac{(2\pi)^2}{\hbar^2} [2(\bar{g} - \bar{g}') \langle P_g^4 \rangle \\ & + (\bar{g}'' - \bar{g}') \langle P_g^2 P_{g''^2} + P_{g''^2} P_g^2 \rangle + \bar{g}' J(J+1) \hbar^2 \langle P_g^2 \rangle] \end{aligned} \quad (III.21)$$

Equation (III.21) thus relates the diagonal values of the cross products of the squares of the angular momentum components in a representation in which  $H_r(v)$  is diagonal, to the diagonal values of the second and fourth powers of the momentum components and the diagonal values of the  $H_r(v)$ . A further expression relating the cross-products of the squares of the components with the second and fourth powers of these components is formed by symmetrically multiplying equation (III.18) by  $P_g^2$  and then taking diagonal values.

$$\begin{aligned} \langle P_g^2 P^2 + P^2 P_g^2 \rangle = & 2\hbar^2 J(J+1) \langle P_g^2 \rangle - 2 \langle P_g^4 \rangle \\ & + \langle P_g^2 P_{g''^2} + P_{g''^2} P_g^2 \rangle + \langle P_{g''^2} P_{g''^2} + P_{g''^2} P_g^2 \rangle \end{aligned} \quad (III.22)$$

Using equations (III.18), (III.21), and (III.22), the diagonal values of  $H_{r'}$  in a representation in which  $H_r(v)$  is diagonal, i.e., the eigen-values of  $H_{r'}$  correct to first order in centrifugal distortion, may be written as:

$$\begin{aligned} \langle H_{r'} \rangle = & W + D_1 W^2 + D_2 W J(J+1) + D_3 J^2(J+1)^2 \\ & + D_4 J(J+1) \langle P_g^2 \rangle + D_5 \langle P_g^4 \rangle + D_6 W \langle P_g^2 \rangle \end{aligned} \quad (III.23)$$

Since the value of  $\langle P_g^2 \rangle$  is given simply as

$$\langle P_g^2 \rangle \frac{2\pi}{\hbar} = \frac{\partial W}{\partial \bar{g}} \quad (III.24)$$

we are left only with the problem of evaluating  $\langle P_g^4 \rangle$  which, in general, is not equal to  $(\langle P_g^2 \rangle)^2$ .

Take  $g = z$  since  $P_z^{2l}$  is a diagonal matrix in the original representation having elements equal to  $\hbar^{2l}K^{2l}$ . Applying the transformation  $X$  leaves  $P_z^{2l}$  unchanged and applying  $T$  yields the diagonal elements of  $P_z^{2l}$  in a representation in which  $H_r(v)$  is diagonal.

$$\langle P_z^{2l} \rangle = \hbar^{2l} \sum_K K^{2l} (J, K', M | T^{-1} | J, K, M) (J, K, M | T | J, K', M) \quad (III.25)$$

Equation (III.25) may also be shown to be equivalent to the expression:

$$\begin{aligned} \langle P_z^{2l} \rangle = & \{ (P_z^{2l})_m + R_{m-1} [(P_z^{2l})_{m-1} + R_{m-2} (\dots)] \\ & + R_{m+1}' [1 + R_{m-2} (1 + \dots)] + R_{m+2}' (\dots) \} \\ & \times \{ 1 + R_{m-1} [1 + R_{m-2} (1 + \dots)] \\ & + R_{m+1}' [1 + R_{m+2}' (1 + \dots)] \}^{-1} \quad (III.25a) \end{aligned}$$

where in the notation of Chapter II

$$\begin{aligned} R_n &= b_{n+1} / [k_n - \lambda_\tau - b_n / (k_{n-1} - \lambda_\tau - \dots)]^2 \\ R_n' &= b_n / [k_n - \lambda_\tau - b_{n+1} / (k_{n+1} - \lambda_\tau - \dots)]^2 \\ (P_z^{2l})_{m \pm n} &= \hbar^{2l} (K \pm 2n)^{2l} \end{aligned}$$

In many cases  $\langle P_z^4 \rangle$  calculated from equation (III.25) will not differ appreciably from  $(\langle P_z^2 \rangle)^2$ , i.e., where  $T^{-1} P_z^2 T \approx \hbar^2 K^2$ .

In the case of symmetric tops equation (III.23) reduces to the simple form

$$\langle H_r' \rangle = W - D_J J^2 (J + 1)^2 - D_{JK} J (J + 1) K^2 - D_K K^4 \quad (III.26)$$

This equation is made relevant for linear rotors by setting  $K = 0$ .

This completes the analysis of centrifugal distortion. The observed spectrum of a molecule in a given vibrational state would be fitted by equation (III.23) by adjusting the three reciprocal moments and the six distortion coefficients,  $D$ . Conversely the  $D$ 's could be calculated from the  $\tau_{ggg'g'}$ 's and the equilibrium reciprocal moments of inertia, the  $\tau$  in turn being calculated from equilibrium structure and the vibrational force constants, if they are known.

## CHAPTER IV

### NUCLEAR QUADRUPOLE ENERGY

THE contribution to the potential energy of a molecule from a nucleus having an internal charge distribution  $\rho_i(X, Y, Z)$  in the presence of an extra-nuclear charge distribution  $\rho_e(X', Y', Z')$  consisting of electrons and other nuclei in a molecule is given as:

$$\int_e \rho_e V dv' \quad . \quad . \quad . \quad . \quad (IV.1)$$

Here 
$$V = \int_i \frac{\rho_i}{R} dv$$

$$R = \sqrt{r_i^2 + r_e^2 - 2r_i r_e \cos \omega}$$

The terms  $r_i$  and  $r_e$  are the radii from the origin of coordinates at the centre of the nuclear mass to a point  $X, Y, Z$ , within the nucleus, and to a point  $X', Y', Z'$  within the extranuclear charge respectively. The angle  $\omega$  is the angle included by  $r_i$  and  $r_e$ . Since we will consider only electronic charges exterior to the nucleus  $r_e > r_i$ , the term  $R^{-1}$  may be expanded in a converging infinite series in  $r_i/r_e$  by the binomial theorem. The potential  $V$  may then be written as

$$V = \int_i \rho_i \left[ \frac{1}{r_e} + \frac{r_i}{r_e^2} \cos \omega + \frac{r_i^2}{r_e^3} \left( \frac{3}{2} \cos^2 \omega - \frac{1}{2} \right) + \dots \right] dv \quad . \quad . \quad (IV.2)$$

The first term in expression (IV.2) is evidently the electrostatic potential at  $X', Y', Z'$  due to a point nuclear charge  $\int \rho_i dv$  at the origin. Such a term will have been taken into account in expressing the Hamiltonian for the sake of determining the molecular electronic states. We therefore

disregard this term here, since we are interested in the perturbation generated by the higher order terms in the expansion of  $V$  which recognize the finite distribution of nuclear charges.

The second term in expression (IV.2) is the potential due to the nuclear electric dipole moment, since

$$\int_i \rho_i \frac{r_i \cos \alpha}{r_e^2} dv = \frac{r_e}{r_e^3} \cdot \int_i \rho_i r_i dv \quad . \quad . \quad (IV.3)$$

and  $\int_i \rho_i r_i dv$  is the nuclear electric dipole moment. Structure of energy levels due to such a term has not been observed, and so we ignore it. Indeed the vanishing of such a term is necessary for a simple picture of a positive nuclear charge, and widely separated nuclear energy levels.

The third term in expression (IV.2) then is of interest since it is the dominant correction term. This term is the expression for the potential due to the electric quadrupole tensor of the nucleus. To observe that this is so, a more convenient form for this may be developed by writing in vector notation and expanding in terms of the components of  $r_i$  and  $r_e$ , as:

$$\frac{3(r_i \cdot r_e)^2 - r_i^2 r_e^2}{2r_e^5} = \sum_F \sum_{F'} \frac{3F_i F_i' F_e F_e'}{2r_e^5} \cdot (F_i F_e)^2 \quad . \quad (IV.4)$$

Here  $F_i = X, Y, Z$  component of  $r_i$

$F_e = X, Y, Z$  component of  $r_e$

This expression, it may be verified, is equivalent to:

$$\frac{1}{6r_e^5} \sum_F \sum_{F'} (3F_i F_i' - \delta_{FF'} r_i^2) (3F_e F_e' - \delta_{FF'} r_e^2) \quad . \quad (IV.5)$$

where  $\delta_{FF'} = 0, F \neq F'$   
 $\delta_{FF'} = 1, F = F'$

The contribution to the energy due to this term may be written as

$$H_Q = \frac{1}{6} \sum_F \sum_{F'} V_{FF'} Q_{FF'} \quad . \quad . \quad (IV.6a)$$

when one defines the tensors

$$V_{FF'} = \int_e \rho_c \frac{(3F_e F_e' - \delta_{FF'} r_e^2)}{r_e^5} dv'$$

$$Q_{FF'} = \int_i \rho_i (3F_i F_i' - \delta_{FF'} r_i^2) dv \quad . \quad . \quad . \quad (IV.7)$$

The elements of the tensor  $V$  are simply the values at the nucleus of the derivatives of the potential due to the extra-nuclear charges, since

$$V_{FF'} = \int_e \rho_c \frac{\partial^2}{\partial F_e \partial F_e'} \left( \frac{1}{r_e} \right) dv' = \left( \frac{\partial^2 V}{\partial F \partial F'} \right)_{r=0} \quad . \quad (IV.8)$$

We may thus write the classical Hamiltonian for the quadrupole energy in either tensor or dyadic notation as:

$$H_Q = \frac{1}{6} \sum_F \sum_{F'} Q_{FF'} V_{FF'}$$

$$= \frac{1}{6} \ddot{Q} : \nabla \dot{E} \quad . \quad . \quad . \quad (IV.6b)$$

The tensor  $Q$  is the charge weighted quadrupole moment for the nucleus in question.

In order to proceed, it is convenient to simplify further the expressions for  $V$  and  $Q$ . It is to be noted that both form tensors with a zero diagonal sum, i.e.,

$$\sum_F Q_{FF} = 0, \quad \sum_F V_{FF} = 0 \quad . \quad . \quad . \quad (IV.9)$$

This property is, of course, invariant under any unitary transformation. Further the tensors are symmetric, i.e.,  $V_{FF'} = V_{F'F}$ ,  $Q_{FF'} = Q_{F'F}$ . Hence, only five terms are needed to determine completely each tensor. For this reason, as may be verified by direct calculation, we may rewrite equation (IV.6b) as:

$$H_Q = \frac{1}{6} \sum_{m=-2}^{+2} V^m Q^{-m} \quad . \quad . \quad . \quad (IV.10)$$

where 
$$V^m = \int_e \rho_e \frac{1}{r_e^5} P_e^m dv'$$

$$Q^m = \int_i \rho_i P_i^m dv$$

$$P^{+2} = \frac{3}{2}(X \pm iY)^2$$

$$P^{+1} = 3Z(X \pm iY)$$

$$P^0 = \frac{\sqrt{6}}{2}(3Z^2 - r^2)$$

$P_e^m$  is in electronic charge co-ordinates

$P_i^m$  is in nuclear charge co-ordinates

The reader familiar with the spherical harmonic addition theorem will recognize that we have, in this backward fashion, derived in fact a particular case for this theorem.

The quadrupole interaction energy in the form given by equation (IV.10) allows a simple translation into quantum mechanical language. In the absence of the electric quadrupole interaction between a nucleus and its surrounding molecule, the nuclear and molecular states, being defined by separate co-ordinates, are separately definable. Hence, molecule and nucleus separately obey the angular momentum commutation relations in equation (I.3), Chapter I, with a plus  $i$ . In a representation in which the square of the molecular rotational angular momentum is diagonal and equal to  $J(J+1)\hbar^2$  and its component on a space fixed  $Z$  axis is  $\hbar M_J$ , the angular momentum matrices are given by equation (I.4), Chapter I. Of similar form are the nuclear angular momentum matrices in a representation in which the square of the nuclear angular momentum is diagonal and equal to  $I(I+1)\hbar^2$  and its  $Z$  axis component is  $\hbar M_I$ .

Since  $r_i$  and  $r_e$  are particle co-ordinate vectors they satisfy the usual commutation relations with the associated angular momentum  $P$ . For example see p. 34.

$$\begin{aligned} X_i Y_i - Y_i X_i &= 0, \text{ etc.} \\ P_{X_i} X_i - X_i P_{X_i} &= 0, \text{ etc.} \\ P_{X_i} Y_i - Y_i P_{X_i} &= i\hbar Z_i, \text{ etc.} \\ P_{X_i} Z_i - Z_i P_{X_i} &= -i\hbar Y_i, \text{ etc.} \end{aligned}$$

Similar relations hold for the rotational angular momentum  $P'$  and the electronic co-ordinates  $X', Y', Z'$ . The  $M$  dependence of the solution to these equations is the same as for the  $\Phi_{Fq}$ , Table 1. Thus, the total matrix elements may be written as the product of an  $M$  independent term and an  $M$  dependent term.

$$\begin{aligned} \mp i(L, M|X \pm iY|L, M \mp 1) &= (L|r|L) \sqrt{(L \pm M)(L \mp M + 1)} \\ i(L, M|X \pm iY|L - 1, M \mp 1) &= (L|r|L - 1) \sqrt{(L \pm M)(L \pm M - 1)} \\ (L, M|Z|L, M) &= (L|r|L)M \\ (L, M|Z|L - 1, M) &= (L|r|L - 1) \sqrt{L^2 - M^2} \quad . \quad (\text{IV.11}) \end{aligned}$$

where  $(L|r|L') = (L, \tau|r|L', \tau')$

Here  $L$  stands for either  $I$  or  $J$ ,  $M$  for either  $M_I$  or  $M_J$ ,  $\tau$  for any other internal quantum numbers, and  $X, Y, Z$  for either  $X, Y, Z$  or  $X', Y', Z'$ .

Using the fact that  $r \times r = 0$  the dependence of the matrix elements of  $P^m$  may thus be written as:

$$\begin{aligned} (L, M|P^{\pm 2}|L, M \pm 2) &= (L|P|L) \sqrt{(L \mp M)(L \mp M - 1)(L \pm M + 1)(L \pm M + 2)} \\ (L, M|P^{\pm 1}|L, M \pm 1) &= (L|P|L)(2M \mp 1) \sqrt{(L \mp M)(L \pm M + 1)} \\ (L, M|P^0|L, M) &= (L|P|L) \sqrt{\frac{2}{3}} [3M^2 - L(L + 1)] \end{aligned}$$

$$(L, M|P^{\pm 2}|L-1, M \pm 2)$$

$$= (L|P|L-1)$$

$$\sqrt{(L+M)(L+M-1)(L+M-2)(L+M+1)}$$

$$(L, M|P^{\pm 1}|L-1, M \pm 1)$$

$$= (L|P|L-1)(L \pm 2M \pm 1)\sqrt{(L+M)(L+M-1)}$$

$$(L, M|P^0|L-1, M)$$

$$= (L|P|L-1)\sqrt{6M\sqrt{L^2-M^2}}$$

$$(L, M|P^{\pm 2}|L-2, M \pm 2)$$

$$= (L|P|L-2)\sqrt{(L+M)(L+M-1)(L+M-2)(L+M+3)}$$

$$(L, M|P^{\pm 1}|L-2, M \pm 1)$$

$$= (L|P|L-2)2\sqrt{(L^2-M^2)(L+M-1)(L+M-2)}$$

$$(L, M|P^0|L-2, M)$$

$$= (L|P|L-2)\sqrt{6}\sqrt{(L^2-M^2)((L-1)^2-M^2)}$$

where

$$(L|P|L') = (L, \tau|P|L', \tau')$$

The matrix elements of  $V^m$  and  $Q^m$  are thus known to within a scale factor which depends only upon the molecular or nuclear geometry, and the total momentum, as signified by the coefficient  $(L|P|L-n)$ , but not upon the  $M$  value. We may determine this constant for a specific value of  $M$ , most conveniently the value  $M = L$  and for a particular component of  $V^m$  and  $Q^m$ , most conveniently from  $V^0$  and  $Q^0$ . For example, we may write, with  $\tau$  as any other internal quantum number, the  $(J|J)$  elements as:

$$(J, \tau, M_J = J|V^0|J, \tau', M_J = J)$$

$$= (J, \tau|C_e|J, \tau')[3J^2 - J(J+1)]$$

$$(I, M_I = I|Q^0|I, M_I = I) = (I|C_q|I)[3I^2 - I(I+1)]$$

. . . (IV.12)

Hence the J and I dependent constants are determined to be:

$$(J, \tau | C_e | J, \tau') = \frac{1}{J(2J-1)} \int_e (J, \tau, M_J = J | \rho_e | J, \tau', M_J = J) \frac{3Z^2 - r^2}{r^5} dv' \quad (IV.13a)$$

This J dependent constant may be written in the form suggested in equation (IV.7) as:

$$(J, \tau | C_e | J, \tau') = \frac{(J, \tau, M_J = J | V_{ZZ} | J, \tau', M_J = J)}{J(2J-1)} \quad (IV.13b)$$

Also:

$$(I | C_i | I) = \frac{1}{I(2I-1)} \int_i (I, M_I = I | \rho_i | I, M_I = I) (3Z^2 - r^2) dv \quad (IV.14a)$$

Similarly the I dependent term may be defined as:

$$(I | C_i | I) = \frac{e(I, M_I = I | Q_{ZZ} | I, M_I = I)}{I(2I-1)} \quad (IV.14b)$$

so that  $Q_{ZZ}$  has the dimensions of length squared.

The general form for V and Q will in this way be found to be given by the product of a J, or I dependent term and an  $M_J$  or  $M_I$  dependent term as:

$$\begin{aligned} (J, \tau, M_J | V^m | J', \tau', M_{J'}) &= \frac{(J, \tau, M_J = J | V_{ZZ} | J', \tau', M_{J'} = J)}{A(J)} (J, M_J | P^m | J', M_{J'}) \\ (I, M_I | Q^m | I', M_{I'}) &= \frac{e(I, M_I = I | Q_{ZZ} | I', M_{I'} = I)}{A(I)} (I, M_I | P^m | I', M_{I'}) \end{aligned} \quad (IV.15)$$

where  $A(L) = L(2L-1)$ ,  $L' = L$

$$= 3L\sqrt{2L+1}, L' = L+1$$

$$= 6\sqrt{(2L+1)(L+1)}, L' = L+2$$

This formal development of the quantum mechanical quadrupole Hamiltonian is rather useless as it stands, for the energy matrix now involves elements which are off diagonal in  $M_I$  and  $M_J$ . This is a consequence of the fact that when the nuclear spin angular momentum and the molecular rotational angular momentum are coupled together only the total angular momentum identified by the quantum number  $F = I + J, I + J - 1, \dots, |I - J|$ , is a constant of the motion. The mutual precession of  $P$  and  $P'$  precludes  $M_I$  and  $M_J$  from being constants of the motion. Thus, we are really interested in transforming from the system  $|I, M_I, J, M_J\rangle$  to the system of the same degree of freedom  $|F, I, J, M_F\rangle$ . Clearly,  $M_I + M_J = M_F$ . For the state  $F = I + J$ , and  $M_F = F$  we must have  $M_I = I$  and  $M_J = J$  or  $|F = I + J, I, J, M_F\rangle = |I, M_I = I, J, M_J = J\rangle$ .

For  $F = I + J - 1, M_F = F$  we may have  $M_I = I, M_J = J - 1$ , or  $M_I = I - 1, M_J = J$ . Hence  $|F = I + J - 1, I, J, M_F = F\rangle = a|I, M_I = I, J, M_J = J - 1\rangle + b|I, M_I = I - 1, J, M_J = J\rangle$ .

The general form of this transformation may be written:

$$|F, I, J, M\rangle = \sum_{M_I, M_J} (M_I, M_J | F, M) |I, M_I, J, M_J\rangle \delta(M_I + M_J, M) \quad (IV.16)$$

where  $(M_I, M_J | F, M)$  are the transformation coefficients, and the  $\delta$  assures that only combinations with  $M_I + M_J = M$  are used. The general form of the coefficients may be deduced algebraically, though we quote only the result of Wigner and Racah:

$$(M_I, M_J | F, M) = \sqrt{\frac{(F+I-J)!(F-I+J)!(I+J-F)!(F+M)!(F-M)!(2F+1)}{(F+I+J+1)!(I-M_I)!(I+M_I)!(J-M_J)!(J+M_J)!}} \times \sum_l (-1)^{l+J+M_J} \frac{(F+J+M_I-l)!(I-M_I+l)!}{(F-I+J-l)!(F+M-l)! (l+I-J-M)!} \quad (IV.17)$$

The index  $l$  is summed over all integral values yielding non-negative factorials.

In principle these  $V^m$  and  $Q^m$  may be written in an  $|F, I, J, M\rangle$  representation using the Wigner coefficients and the  $|l, M_l, J, M_J\rangle$  matrix elements. Far more practical, however, is it to use the method of Racah to develop directly the matrix elements of  $H_Q$  in the  $|F, I, J, M\rangle$  scheme from the matrix elements in the  $|l, M_l, J, M_J\rangle$  scheme. We quote here only the results of these calculations for the elements diagonal in  $I$ , since the  $(I|I \pm n)$  elements can have practically no effect due to their extreme energy separation:

$$\begin{aligned} & (F, J, \tau, M | H_Q | F, J, \tau', M) \\ &= \frac{eQ_{ZZ}(J, \tau, M_J - J | V_{ZZ} | J, \tau', M_J - J)}{8I(2I - 1)J(2J - 1)} \\ & \quad \times [3C(C + 1) - 4I(I + 1)J(J + 1)] \quad . \quad (IV.19a) \end{aligned}$$

$$\begin{aligned} & (F, J, \tau, M | H_Q | F, J + 1, \tau', M) \\ &= \frac{eQ_{ZZ}(J, \tau, M_J - J | V_{ZZ} | J + 1, \tau', M_J - J)}{8I(2I - 1)J\sqrt{2J + 1}} \\ & \quad \times [F(F + 1) - I(I + 1) - J(J + 2)] \\ & \quad \times [(I + J + F + 2)(I - J + F)(J - I + F + 1) \\ & \quad \times (J + I - F + 1)]^{\frac{1}{2}} \quad . \quad . \quad . \quad (IV.19b) \end{aligned}$$

$$\begin{aligned} & (F, J, \tau, M | H_Q | F, J + 2, \tau', M) \\ &= \frac{eQ_{ZZ}(J, \tau, M_J - J | V_{ZZ} | J + 2, \tau', M_J - J)}{16I(2I - 1)(2J + 1)(J + 1)^{\frac{1}{2}}} \\ & \quad \times [(I + J + F + 2)(I + J + F + 3)(I - J + F - 1) \\ & \quad \times (I - J + F)(J - I + F + 1)(J - I + F + 2) \\ & \quad \times (I + J - F + 1)(I + J - F + 2)]^{\frac{1}{2}} \quad . \quad . \quad (IV.19c) \end{aligned}$$

where  $C = F(F + 1) - I(I + 1) - J(J + 1)$

The diagonal elements may also be developed readily by noting that the matrix elements of the components of  $r$

diagonal in  $L(J \text{ or } I)$ , are the same, except for a scale factor, as those for the components of nuclear or molecular angular momentum,  $P_F$  and  $P_{F'}$ . Thus equation (IV.7) may be written as

$$V_{FF'} = C_e \int_e \rho_e \left[ \frac{3}{2} (P_{F'} P_{F'} + P_{F'} P_{F'}) - \delta_{FF'} (P')^2 \right] dv'$$

$$Q_{FF'} = C_1 \int_i \rho_e \left[ \frac{3}{2} (P_F P_{F'} + P_{F'} P_F) - \delta_{FF'} P^2 \right] dv \quad . \quad (IV.20)$$

The symmetrical form is used since the components of  $P$  and of  $P'$ , the nuclear and molecular angular momentum, do not commute. The constant is evaluated as for equation (IV.4) and the multiplication is carried out to yield

$$H_Q = \frac{e Q_{ZZ} (J, \tau, M_J - J) |V_{ZZ}| (J, \tau', M_J - J)}{2I(2I - 1)J(2J - 1)\hbar^4} \left[ \frac{3}{4} (2P \cdot P')(2P \cdot P' + \hbar^2) - P^2(P')^2 \right] \quad . \quad (IV.21)$$

Since  $2P \cdot P' = P_{total}^2 - P^2 - (P')^2$  then in the  $|F, I, J, M\rangle$  scheme this is diagonal and equal to  $[F(F + 1) - J(J + 1) - I(I + 1)]\hbar^2$ , we have the result given in equation (IV.19a).

The final problem then is that of evaluating the  $J$  dependence of  $V_{ZZ}$ . By means of the direction cosine matrix elements, this factor may be written in terms of the derivatives of the potential taken along molecule fixed co-ordinates, which, for a given vibrational and electronic state, will be constants of the molecule. By definition  $V_{ZZ}$  involves the direction cosines as:

$$V_{ZZ} = \sum_g \sum_{g'} \Phi_{Zg} \Phi_{Zg'} V_{gg'} \quad . \quad (IV.22)$$

where  $V_{gg'} = \frac{\partial^2 V}{\partial g \partial g'}$

In a representation in which the unperturbed rotational energy is diagonal we have:

$$V_{ZZ} = \sum_g \sum_{g'} T^{-1} X^{-1} \Phi_{Zg} \Phi_{Zg'} X T V_{gg'} \quad . \quad (IV.23)$$

The diagonal elements are readily evaluated since all products of direction cosines with  $g \neq g'$  have no diagonal elements in either form given above.

Thus

$$\begin{aligned} (J, \tau, M_J = J | V_{ZZ} | J, \tau, M_J = J) \\ = (J, \tau, M_J = J | \sum_g T^{-1} X^{-1} \Phi_{Zg}^2 X T | J, \tau, M_J = J) V_{gg} \end{aligned} \quad (IV.24)$$

Further it may be readily seen from the known matrix elements of the direction cosines (Table 1, Chapter I) that

$$\begin{aligned} (J, K, M_J = J | \Phi_{Fg}^2 | J, K', M_J = J) \\ = (J, K | P_g^2 | J, K') \frac{2}{(J+1)(2J+3)\hbar^2} + \frac{\delta_{KK'}}{(2J+3)} \end{aligned} \quad (IV.25)$$

If  $H_r$  is made diagonal with the transformation  $XT$

$$\begin{aligned} (J, \tau, M_J = J | T^{-1} X^{-1} \Phi_{Fg}^2 X T | J, \tau, M_J = J) \\ = (J, \tau | P_g^2 | J, \tau) \frac{2}{(J+1)(2J+3)\hbar^2} + \frac{1}{(2J+3)} \end{aligned} \quad (IV.26)$$

We have shown in Chapter II that the diagonal elements of  $P_g^2$  may be written in terms of  $E_\tau^J(\kappa)$  and its derivative with respect to  $\kappa$ . Thus, we have for the diagonal elements of  $V_{ZZ}$  the relation

$$\begin{aligned} (J, \tau, M_J = J | V_{ZZ} | J, \tau, M_J = J) \\ = \frac{2}{(J+1)(2J+3)} \left\{ \frac{1}{2} V_{aa} \left[ J(J+1) + E_\tau^J(\kappa) - (\kappa+1) \frac{dE_\tau^J(\kappa)}{d\kappa} \right] \right. \\ \left. + V_{bb} \frac{dE_\tau^J(\kappa)}{d\kappa} + \frac{1}{2} V_{cc} \left[ J(J+1) - E_\tau^J(\kappa) \right. \right. \\ \left. \left. + (\kappa-1) \frac{dE_\tau^J(\kappa)}{d\kappa} \right] \right\} \quad (IV.27) \end{aligned}$$

In deriving the form of equation (IV.27), use has been made of the fact that  $\sum_g V_{gg} = 0$ , since at the origin where the

electronic charge is zero the potential due to the extranuclear charges satisfies Laplace's equation. Actually this is an approximation. Electrons with spherically symmetric angular distribution may have a finite expectation value at  $r = 0$ . However, these electrons cannot contribute to  $V_{ZZ}$  by virtue of their symmetry and hence  $\rho_e$  may be set equal to zero within the nucleus with no loss in rigour.

Alternatively, we may proceed to calculate the diagonal elements of  $V_{ZZ}$  by evaluating the diagonal elements of the squares of the direction cosines. A convenient quantity, tabulated in Appendix II is the line strength which is defined as:

$$(J, \tau | \lambda_g | J', \tau') = 3 \sum_M |(J, \tau, M | T^{-1} X^{-1} \Phi_{Zg} X T | J', \tau', M)|^2 \quad . \quad . \quad (IV.28)$$

But the right-hand side is certainly just

$$3 \sum_M (J, \tau, M | T^{-1} X^{-1} \Phi_{Zg} X T | J', \tau', M) (J', \tau', M | T^{-1} X^{-1} \Phi_{Zg} X T | J, \tau, M)$$

Since  $X T$  is diagonal in  $M$  the summation over  $M$  may be undone and we have:

$$(J, \tau, M = J | T^{-1} X^{-1} \Phi_{Zg} X T | J', \tau', M = J) (J', \tau', M = J | T^{-1} X^{-1} \Phi_{Zg} X T | J, \tau, M = J) = (J, \tau | \lambda_g | J', \tau') S \quad . \quad . \quad (IV.29)$$

where

$$S = \begin{aligned} & \frac{J}{(J+1)(2J+1)}, J' = J \\ & \frac{J}{(J+1)(2J+3)}, J' = J+1 \\ & = 0, \quad J' = J-1 \end{aligned}$$

The  $K$ -dependent term of  $\Phi_{Zg}^2$  may be summed readily as

$$\sum_{J'=J}^{J+1} |(J, K | \Phi_{Zg} | J', K')|^2 = 4(J+1)^2 \quad . \quad (IV.30)$$

Since  $\mathbf{XT}$  is unitary and diagonal in  $J$ , this sum is unchanged by the transformation  $\mathbf{XT}$ . Thus

$$\sum_{\tau'} |(J, \tau | \mathbf{T}^{-1} \mathbf{X}^{-1} \Phi_{Zg} \mathbf{XT} | J+1, \tau')|^2 = 4(J+1)^2 \sum_{\tau'} |(J, \tau | \mathbf{T}^{-1} \mathbf{X}^{-1} \Phi_{Zg} \mathbf{XT} | J, \tau')|^2 \quad (\text{IV.31})$$

Including the  $J$  and  $M$  dependence of  $\Phi_{Zg}$  we have:

$$\begin{aligned} & \sum_{\tau'} |(J, \tau, M-J | \mathbf{T}^{-1} \mathbf{X}^{-1} \Phi_{Zg} \mathbf{XT} | J+1, \tau', M-J)|^2 \\ &= \frac{1}{4(J+1)^2(2J+3)} \\ & \quad [4(J+1)^2 \sum_{\tau'} |(J, \tau | \mathbf{T}^{-1} \mathbf{X}^{-1} \Phi_{Zg} \mathbf{XT} | J, \tau')|^2 \\ & \quad - \frac{1}{(2J+3)} \\ & \quad [1 - \sum_{\tau'} |(J, \tau, M-J | \mathbf{T}^{-1} \mathbf{X}^{-1} \Phi_{Zg} \mathbf{XT} | J, \tau', M-J)|^2] \end{aligned} \quad (\text{IV.32})$$

The diagonal elements of equation (IV.23) are thus written

$$(J, \tau, M_J = J | V_{ZZ} | J, \tau, M_J = J) = \frac{2J}{(2J+1)(2J+3)} \sum_g \sum_{\tau'} (J, \tau | \lambda_g | J, \tau') V_{gg} \quad (\text{IV.33})$$

The general asymmetric rotor energy in the presence of a nuclear quadrupole moment may thus be written as a large diagonal contribution evaluated from equations (IV.33) or (IV.27) and equation (IV.19a). The off-diagonal elements given by (IV.19b) and (IV.19c) have to be determined knowing the transformation  $\mathbf{XT}$  and using equation (IV.23). The contribution of these terms, when they are reduced to the diagonal will be seen to be of the form

$$\Delta W_Q(J, \tau) = \sum_{J', \tau'} \frac{|(F, J, \tau | \mathbf{H}_Q | F, J', \tau')|^2}{W(F, J, \tau) - W(F, J', \tau')} \quad (\text{IV.34})$$

For rotational states with  $J = 0$ , the energy diagonal in  $J$  is identically zero, as it is for nuclear states for  $I = 0, \frac{1}{2}$ .

Since these are symmetric states both  $V_{zz}$  and  $Q_{zz}$  must be respectively zero.

The symmetric rotor, having the nuclear quadrupole on the symmetry axis may be handled explicitly as a specialization of the above treatment. From symmetry  $V_{gg'} = 0$  if  $g \neq g'$ , further  $V_{xx} = V_{yy} = \frac{1}{2}V_{zz}$ .

The symmetric rotor formulas then, which may be specialized to linear rotors in ground states of degenerate vibrations by setting  $K = 0$ , may be written as (again only elements diagonal in  $I$  are needed):

$$\begin{aligned}
 (F, J, K | V_{zz} | F, J, K) &= \frac{3K^2 - J(J+1)}{(J+1)(2J+3)} V_{zz} \\
 (F, J, K | V_{zz} | F, J+1, K) &= \frac{3K[(J+1)^2 - K^2]^{\frac{1}{2}}}{[(J+1)(J+2)(2J+3)]^{\frac{1}{2}}} V_{zz} \\
 (F, J, K | V_{zz} | F, J+2, K) &= \frac{3\{[(J+1)^2 - K^2][(J+2)^2 - K^2]\}^{\frac{1}{2}}}{(J+2)(2J+3)[(J+1)(2J+5)]^{\frac{1}{2}}} V_{zz} \quad . \quad (IV.35)
 \end{aligned}$$

In general, then, a rotational state  $J \geq 1$  will be split by the nuclear quadrupole energy into a number of states corresponding to different values of total angular momentum  $F = I + J, I + J - 1, \dots, |I - J|$ . The total intensity of this fine structure is the same as in the absence of the quadrupole energy. Only the relative intensities, then, need to be calculated. These calculations are carried out in several places. Though highly impractical, the direction cosine matrix elements could be transformed by the Wigner coefficients to the  $|F, I, J, M\rangle$  representation. We quote here only the results. The selection rule on  $F$  is  $\Delta F = 0, \pm 1$ .

For  $\Delta J = 0$  we have the relative intensities as:

$$\begin{aligned}
 (F, J | \lambda | F+1, J) &= \frac{P(F+1)Q(F)}{2(F+1)} \\
 (F, J | \lambda | F, J) &= \frac{(2F+1)R(F)}{2F(F+1)}
 \end{aligned}$$

$$(F, J|\lambda|F - 1, J) = \frac{P(F)Q(F - 1)}{2F} \\ \Delta J = 1$$

$$(F, J|\lambda|F + 1, J + 1) = \frac{\sqrt{P(F + 2)P(F + 1)}}{4(F + 1)}$$

$$(F, J|\lambda|F, J + 1) = (2F + 1) \frac{\sqrt{P(F + 1)Q(F - 1)}}{4F(F + 1)}$$

$$(F, J|\lambda|F - 1, J + 1) = \frac{\sqrt{Q(F - 1)Q(F - 2)}}{4F}$$

where  $(F, J|\lambda|F', J') = (F', J'|\lambda|F, J)$

$$P(F) = (F - I + J)(F + I + J + 1)$$

$$Q(F) = (I + J - F)(F + I - J + 1)$$

$$R(F) = F(F + 1) - I(I + 1) - J(J + 1)$$

Tables of these relative multiplet intensities are available in the literature.

## CHAPTER V

### STARK EFFECT

THE presence of a uniform static electric field  $\epsilon$  increases the potential energy of a molecule with a permanent electric dipole moment by  $-\mu \cdot \epsilon$ . This term, when added to the total Hamiltonian, may be considered by transforming the components of the electric dipole moment from molecule fixed axes to the space fixed axis parallel to  $\epsilon$  by means of the direction cosine transformations (equation (I.5a), Chapter I). With no loss in generality we may take  $\epsilon$  along the Z axis and hence the perturbation energy has the form

$$\mathbf{H}_s = -\epsilon_Z \sum_g \mu_g \Phi_{Zg} \quad . \quad . \quad . \quad (V.1)$$

Since the matrix elements of the direction cosines are known (Table 1) the perturbation matrix which must be added to the rotational energy matrix is immediately determined.

It will be noted that since the direction cosines have matrix elements off diagonal in J (i.e.,  $(J|J \pm 1)$ ) and K (i.e.,  $(K|K \pm 1)$ ) the rotational energy plus Stark energy matrix may no longer be factored and hence, it must be diagonalized by approximate methods.

The transformation which diagonalizes the factored, reduced energy matrix in the absence of the static electric field is known from equation (II.19), Chapter II, page 15. The rotational energy plus Stark energy matrix may be made nearly diagonal by applying this same transformation.

$$\mathbf{T}^{-1}\mathbf{X}^{-1}(\mathbf{H}_r + \mathbf{H}_s)\mathbf{X}\mathbf{T} = \mathbf{W}_\tau - \epsilon_Z \sum_g \mu_g \mathbf{T}^{-1}\mathbf{X}^{-1}\Phi_{Zg}\mathbf{X}\mathbf{T} \quad . \quad . \quad (V.2)$$

Both X and T are matrices diagonal in J, while  $\Phi_{Zg}$  has elements both diagonal in J and off-diagonal in J by  $\pm 1$ . It is readily shown that the application of the symmetrizing

transformation leaves  $X^{-1}\Phi_{Zg}X$  with no elements diagonal in both  $J$  and  $K$  since the matrix elements of  $\Phi_{Zg}$  diagonal in  $J$  and  $K$  have odd symmetry in  $K$ . The only other matrix elements of  $\Phi_{Zg}$  diagonal in  $J$  are  $(K|K \pm 1)$ . For these

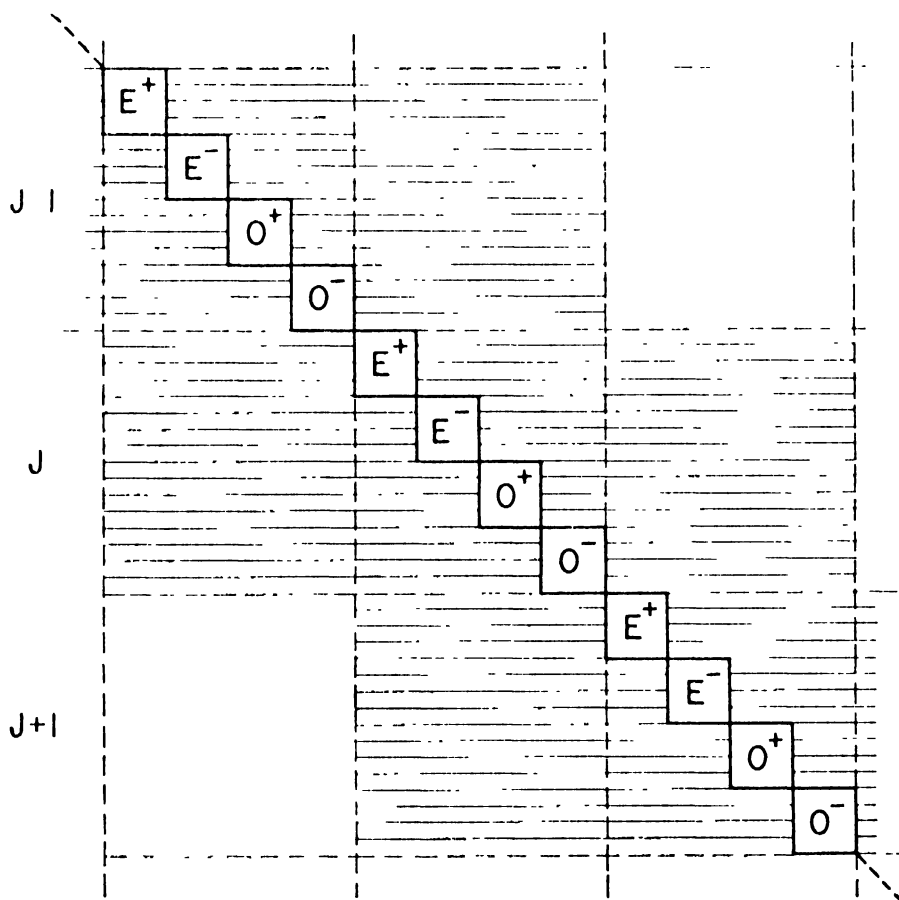

Fig. 3. Stark-rotation energy matrix

reasons  $X^{-1}\Phi_{Zg}X$  will have no matrix elements within any one reduced energy factor,  $E_E^J(\kappa)$  or  $E_0^J(\kappa)$ , since they are composed totally of either even or odd  $K$  numbers. The perturbation matrix  $X^{-1}\Phi_{Zg}X$  will only have matrix elements between the factored sub-matrices  $E_{E\pm}^{J'}(\kappa)$ ,  $E_{0\pm}^{J'}(\kappa)$  with  $J' = J, J \pm 1$ . The matrix expressed in equation (V.2) will have the form shown in Fig. 3, the perturbation matrix  $\sum_g \mu_g \epsilon_Z T^{-1} X^{-1} \Phi_{Zg} X T$  occupying the shaded region.

This matrix is now diagonalized by the continued fraction method of Chapter II, by assuming a solution  $W'_\tau = W_\tau + \Delta W_\tau$ . All terms such as

$$\frac{|(J, \tau''', M | \mu_g \Phi_{Zg} \epsilon_Z | J, \tau'', M)|^2}{W_{\tau'''} - W_{\tau}}$$

and  $\Delta W_{\tau}$ , are ignored with regard to terms having  $W_{\tau''} - W_{\tau}$  in the denominators (i.e., the electric field perturbation energy is assumed small with respect to the interval between rotational energy states). The usual second order perturbation energy formula then results to give the perturbed energy as:

$$\Delta W_{\tau} = - \sum_{\tau' \neq \tau''} \frac{\sum_g |(J, \tau, M | T^{-1} X^{-1} \Phi_{Zg} X T | J', \tau', M)|^2 \mu_g^2 \epsilon_Z^2}{W_{\tau'} - W_{\tau}} \dots \quad (V.3)$$

Consider now the effect of degeneracies or near degeneracies. Suppose that in one of the denominators of equation (V.3),  $W_{\tau''} \simeq W_{\tau}$ , so the  $\Delta W_{\tau}$  may not be ignored with respect to their difference, although other terms in the denominator, such as

$$\frac{|(J, \tau''', M | T^{-1} X^{-1} \Phi_{Zg} X T | J, \tau'', M)|^2 \mu_g^2 \epsilon_Z^2}{W_{\tau'''} - W_{\tau'}}$$

may be ignored with respect to  $\Delta W_{\tau}$ . Equation (V.3) is best rewritten in the form:

$$\Delta W_{\tau} = - \frac{\mu_g^2 \epsilon_Z^2 |(J, \tau, M | T^{-1} X^{-1} \Phi_{Zg} X T | J'', \tau'', M)|^2}{W_{\tau''} - W_{\tau} - \Delta W_{\tau}} - \sum_{\substack{\tau' \neq \tau \\ \tau' \neq \tau''}} \frac{\sum_g |(J, \tau, M | T^{-1} X^{-1} \Phi_{Zg} X T | J', \tau', M)|^2 \mu_g^2 \epsilon_Z^2}{W_{\tau'} - W_{\tau}} \dots \quad (V.4)$$

Solving for  $\Delta W_{\tau}$  we have

$$\Delta W_{\tau} = \frac{W_{\tau''} - W_{\tau}}{2} - \frac{1}{2} \sum_{\substack{\tau' \neq \tau \\ \tau' \neq \tau''}} \frac{\sum_g |(J, \tau, M | T^{-1} X^{-1} \Phi_{Zg} X T | J', \tau', M)|^2 \mu_g^2 \epsilon_Z^2}{W_{\tau'} - W_{\tau}} \pm \left\{ \frac{1}{4} [W_{\tau''} - W_{\tau} + \sum_{\substack{\tau' \neq \tau \\ \tau' \neq \tau''}} (\dots)]^2 - \mu_g^2 \epsilon_Z^2 |(J, \tau, M | T^{-1} X^{-1} \Phi_{Zg} X T | J'', \tau'', M)|^2 \right\}^{\frac{1}{2}} \quad (V.5)$$

The plus sign is taken when  $W_{\tau''} < W_{\tau}$  and the minus sign is taken when  $W_{\tau''} > W_{\tau}$ .

The symmetric rotor, for example, has doubly degenerate  $K$  levels. In this case  $W_{\tau''} = W_{\tau}$ . Following equation (II.27), Chapter II, if  $\tau$  is given as  $\pm (J - 2K)$ ,  $\tau''$  would then be given as  $\pm (J - 2K + 1)$ , with  $K$  the value of the  $K$  assigned to the degenerate levels. The perturbation due to the electric field may now be simplified to the form

$$\begin{aligned} \Delta W_K = & \pm \mu_q \epsilon_Z (J, K, M | \Phi_{Zq} | J, K, M) \\ & - \sum_{0 \leq K' \neq K} \frac{\sum_q \mu_q^2 \epsilon_Z^2 | (J, K, M | \Phi_{Zq} | J', K', M) |^2}{W_{K'} - W_K} \end{aligned} \quad (V.6)$$

Use has been made of the fact that (1)  $T$  is a diagonal matrix, and (2) each value of  $\tau' = \pm (J - 2K \pm \begin{Bmatrix} 0 \\ 1 \end{Bmatrix})$  for a given value of  $K \neq 0$  yields an identical term in the sum (hence the sum may be made over  $K$  and the result multiplied by 2). Further if  $\tau'$  corresponds to a state having  $K = 0$  then  $\tau$  must correspond to a state for  $K \neq 0$  and summation over  $K$  still requires multiplication by 2, since

$$(J', \tau', M | X^{-1} \Phi_{Zq} X | J, \tau, M) = \sqrt{2} (J', 0, M | \Phi_{Zq} | J, K, M)$$

The  $\pm$  sign in equation (V.6) accounts for the two levels which result when the electric field removes the "K" degeneracy.

The values of  $W_K$  are given in equations (II.24) and (II.25) of Chapter II, page 17; the values of  $\Phi_{Zq}$  in Table 1, page 4. By symmetry, a symmetric top molecule may have an electric moment only along the symmetry or  $z$  axis. Equation (V.6) may be written explicitly as:

$$\begin{aligned} \Delta W_{J, K} = & \pm \frac{MK}{J(J+1)} \mu_z \epsilon_Z - \frac{I_z \mu_z^2 \epsilon_Z^2}{\hbar^2} \left\{ \frac{(J^2 - K^2)(J^2 - M^2)}{(J^3(2J-1)(2J+1))} \right. \\ & \left. - \frac{[(J+1)^2 - K^2][(J+1)^2 - M^2]}{(J+1)^3(2J+1)(2J+3)} \right\} \quad (V.7) \end{aligned}$$

For a linear rotor equation (V.7) simplifies ( $K = 0$ ) to the expression

$$\Delta W_J = \frac{I\mu^2 \epsilon_Z^2}{\hbar^2} \left\{ \frac{J(J+1) - 3M^2}{J(J+1)(2J-1)(2J+3)} \right\} \quad (V.8)$$

The possibility does exist that a degeneracy or near degeneracy occurs for levels between which there is no Stark coupling element. In this case a term such as

$$\frac{|(J, \tau'', M|T^{-1}X^{-1}\Phi_{Zg}XT|J, \tau'', M)|^2}{W_{\tau''} - W_{\tau} - \Delta W_{\tau}}$$

must be considered in the denominator of one term of the summation in equation (V.6). Equation (V.3) is rewritten as

$$\Delta W_{\tau} = \frac{\sum_{\substack{\tau' \neq \tau \\ \tau' \neq \tau''}} \sum_g \mu_g^2 \epsilon_Z^2 |(J, \tau, M|T^{-1}X^{-1}\Phi_{Zg}XT|J', \tau', M)|^2}{W_{\tau'} - W_{\tau}} - \frac{|(J, \tau, M|T^{-1}X^{-1}\Phi_{Zg}XT|J'', \tau'', M)|^2 \mu_g^2 \epsilon_Z^2}{W_{\tau''} - W_{\tau} - \Delta W_{\tau}} - \frac{|(J'', \tau'', M|T^{-1}X^{-1}\Phi_{Zg}XT|J''', \tau''', M)|^2 \mu_g^2 \epsilon_Z^2}{W_{\tau'''} - W_{\tau} - \Delta W_{\tau}} \quad (V.9)$$

This is a cubic equation for  $\Delta W_{\tau}$  and may be solved in any specific case. For example, if

$$(W_{\tau'''} - W_{\tau} - \Delta W_{\tau})(W_{\tau'''} - W_{\tau}) \ll |(J'', \tau'', M|T^{-1}X^{-1}\Phi_{Zg}XT|J''', \tau''', M)|^2 \mu_g^2 \epsilon_Z^2 \quad (V.10)$$

then

$$\Delta W_{\tau} = \frac{1}{1 - \rho} \left[ - \sum_{\substack{\tau' \neq \tau \\ \tau' \neq \tau''}} \sum_g \mu_g^2 \epsilon_Z^2 \frac{|(J', \tau', M|T^{-1}X^{-1}\Phi_{Zg}XT|J, \tau, M)|^2}{W_{\tau'} - W_{\tau}} + \rho(W_{\tau'''} - W_{\tau}) \right] \quad (V.11)$$

where  $\rho = \frac{|(J'', \tau'', M|T^{-1}X^{-1}\Phi_{Zg}XT|J, \tau, M)|^2}{|(J'', \tau'', M|T^{-1}X^{-1}\Phi_{Zg}XT|J''', \tau''', M)|^2}$

In practice the inequality in equation (V.10) would be reversed in which case the usual expression for the perturbation energy in the absence of degeneracy, equation (V.3), would hold. More remote degeneracies than those discussed above are indeed negligible. In fact, Stark perturbation energies are seldom complicated by degeneracies; the few examples listed in the bibliography are rather exceptional cases.

The evaluation of the theoretical Stark perturbation for asymmetric top molecules is arduous in that the diagonalizing transformation  $T$  must be calculated to evaluate the appropriate direction cosine matrix elements of equation (V.3). This calculation is greatly simplified by observing that the quantity, the line strength, is defined as

$$(J, \tau | \lambda_g | J', \tau') = 3 \sum_{\mathbf{M}} |(J, \tau, \mathbf{M} | T^{-1} X^{-1} \Phi_{Zg} X T | J', \tau', \mathbf{M})|^2 \quad . \quad . \quad (V.12)$$

The line strength has been used in Chapter IV and values for  $J \leq 12$  are tabulated in Appendix II.

The summation over  $\mathbf{M}$  may be undone by observing that  $X$  and  $T$  are diagonal in  $J$  and  $\mathbf{M}$  and hence the  $\mathbf{M}$  and  $J$  dependence of  $T^{-1} X^{-1} \Phi_{Zg} X T$  is identical to that of  $\Phi_{Zg}$ . Equation (V.12) may be written

$$(J, \tau | \lambda_g | J', \tau') = 3 |(J | \Phi_{Zg} | J')|^2 |(J, \tau | T^{-1} X^{-1} \Phi_{Zg} X T | J', \tau')|^2 \sum_{\mathbf{M}} |(J, \mathbf{M} | \Phi_{Zg} | J', \mathbf{M})|^2 \quad . \quad . \quad (V.13)$$

From Table 1, page 4, it is seen that:

$$\begin{aligned} J' = J, & \quad |(J, \mathbf{M} | \Phi_{Zg} | J', \mathbf{M})|^2 = 4M^2 \\ J' = J + 1, & \quad |(J, \mathbf{M} | \Phi_{Zg} | J', \mathbf{M})|^2 = 4[(J + 1)^2 - M^2] \\ J' = J - 1, & \quad |(J, \mathbf{M} | \Phi_{Zg} | J', \mathbf{M})|^2 = 4[J^2 - M^2] \quad . \quad (V.14) \end{aligned}$$

Noting that

$$\sum_{-\mathbf{J}}^{\mathbf{J}} M^2 = \frac{1}{3} J(J + 1)(2J + 1) \quad . \quad . \quad (V.15)$$

equation (V.13) may be rewritten

$$(J, \tau, \mathbf{M} | T^{-1} X^{-1} \Phi_{Zg} X T | J', \tau', \mathbf{M})|^2 = (J, \tau | \lambda_g | J', \tau') R \quad . \quad . \quad (V.16)$$

$$\begin{aligned} \text{where } R_{J, \tau} &= \frac{M^2}{J(J+1)(2J+1)} \quad J' = J \\ R_{J, \tau} &= \frac{J'^2 - M^2}{J'(2J'+1)(2J'+1)} \quad J' = J+1 \\ R_{J, \tau} &= \frac{J^2 - M^2}{J(2J-1)(2J-1)} \quad J' = J-1 \end{aligned}$$

Values of  $(J, \tau | \lambda_g | J', \tau')$  may be determined by interpolation in the tables of Appendix II for any value of  $\kappa$ , and  $W_{\tau'} - W_{\tau}$  is calculated from the rigid rotor term values or determined directly from experimental data. It is the usual case that the most important term in the summation of equation (V.3) is that arising from the smallest energy denominator and that this energy difference corresponds to the observed transition frequency in the microwave region. The other energy differences would correspond to much larger, and possibly unobservable, frequency differences and hence need to be less exactly known. A crude model of the molecule will suffice for their calculation. Stated another way, the important term in the Stark perturbation sum will be that one with a small energy denominator, and hence will correspond to an accurately determined microwave absorption frequency, usually that one for which the Stark effect is being observed. The other terms are small correction terms and need be only crudely known.

A final observation on the use of the Stark effect for identification of transitions may be made. As has been shown above the transformation XT is diagonal in J and M. Hence the M dependence of the direction cosine matrix elements and  $(J, \tau | \lambda_g | J', \tau')$  is independent of these transformations. The  $|(J, M | J, M)|^2$  elements have a pure  $M^2$  dependence, while the  $|(J', M | J, M)|^2$  elements have a dependence of the form  $(J^{*2} - M^2)$ , where  $J^*$  is taken as the larger of J or  $J'$ . The Stark perturbation then will have the form  $[A(J, \tau) + B(J, \tau)M^2] \epsilon^2$ . For  $\Delta M = 0$ ,  $\pi$ -type transitions, that is for transitions induced by an electromagnetic field parallel to the static electric field  $J^* \pm 1$  components will be observed, where  $J^*$

## CHAPTER VI

### ZEEMAN EFFECT

WHEN a static magnetic field  $B$  is imposed on a rotating molecule the Hamiltonian must be corrected to include a term indicating the interaction of the molecule with this field. This term may be symbolized by:

$$H_m = -\mu \cdot B \quad . \quad . \quad . \quad (VI.1)$$

Here  $\mu$  is the net, effective magnetic moment of the molecule including the contributions from electronic spin and orbital (rotational) angular momentum and the nuclear spin and orbital (rotational) angular momentum. Since so few molecules have other than  $^1\Sigma$  ground states (electronic spin angular momentum other than zero), we consider here only  $^1\Sigma$  molecules. Examples of molecules not having  $^1\Sigma$  ground states would be  $O_2$ ,  $NO$ .

We may start from the defining equation for a magnetic moment of charges in motion, to account for orbital contributions of the charges to the effective magnetic moment of a molecule. This relation is:

$$\mu = \frac{1}{2c} \sum_i e_i (r_i \times v_i) \quad . \quad . \quad . \quad (VI.2)$$

where  $e_i$  is the charge on the  $i$ th particle,  $r_i$  is the position vector of the  $i$ th particle from an arbitrary origin,  $v_i$  is the velocity vector of the  $i$ th particle and the sum is taken over all particles.

With no loss in generality  $B$  may be taken along the space fixed  $Z$  axis. It is convenient to express  $\mu$  in terms of the molecule fixed axes, so the dot product of equation (VI.1) may be represented in terms of the direction cosines as:

$$H_m = - \sum_g \mu_g \Phi_{Zg} B_Z \quad . \quad . \quad . \quad (VI.3)$$

The problem then resolves into one of expressing  $\mu$  in terms of the rotational and geometric parameters related to the molecule fixed axes.

The nuclei may be taken to form a rigid framework, as is conventional for these problems. This introduces a tremendous simplification in the analytic problem and in most cases the error incurred will be well beyond experimental detection. We will return later to a discussion of the effect of a non-rigid framework where vibrational and centrifugal distortion may modify our results.

Equation (VI.2) is then expanded and all quantities are referred to the principal axes of inertia. A typical component of the nuclear rotational magnetic moment has the form:

$$\mu_y^n = \frac{1}{2c} \sum_k e_k [(g_k'^2 + g_k''^2) \omega_g - g_k g_k' \omega_{g'} - g_k g_k'' \omega_{g''}] \quad \text{(VI.4)}$$

where  $e_k$  is the charge of the  $k$ th nucleus,  $g, g',$  and  $g''$  are the co-ordinates of the  $k$ th particle referred to the principal inertial axes and  $\omega_g, \omega_{g'},$  and  $\omega_{g''}$  are the angular velocities resolved along the inertial axes. But

$$\omega_g = \frac{P_g}{I_g} \quad \text{(VI.5)}$$

and so 
$$\mu_y^n = \sum_{g'} G_{gg'}^n P_{g'} \quad \text{(VI.6)}$$

where 
$$G_{gg}^n = \frac{1}{2cI_g} \sum_k e_k (g_k'^2 + g_k''^2)$$

is a typical diagonal element of the  $G_{gg'}^n$  tensor and

$$G_{gg'}^n = -\frac{1}{2cI_{g'}} \sum_k e_k g_k g_k'$$

is a typical off-diagonal element.

It should be noted that  $P_{g'}$  does not commute with  $\Phi_{Z_g}$  if  $g \neq g'$ , and so in introducing equation (VI.6) into equation (VI.3) a symmetrized form must be used. The contribution

to the energy due to the nuclear orbital (rotational) angular momentum is thus written as:

$$H_m^n = -\frac{1}{2}B\sum_g\sum_{g'}G_{gg'}(P_{g'}\Phi_{Zg} + \Phi_{Zg}P_{g'}) \quad (\text{VI.7})$$

The electronic cloud of the molecule will have a certain amount of orbital angular momentum ( $L$ ) since it will follow more or less the rotation of the nuclear axis. Since all electrons have the same  $e/m$  value equation (VI.2) may be written in the particularly simple form:

$$\mu_g^e = -\frac{e}{2mc}L_g$$

where 
$$L_g = \sum_i m_i (r_i \times v_i)_g \quad (\text{VI.8})$$

Combining equations (VI.3) and (VI.8), the contribution to the energy due to the electronic orbital (rotational) angular momentum is written as:

$$H_m^e = \frac{e}{2mc}B_Z\sum_g L_g\Phi_{Zg}$$

In Chapter II, we essentially lumped the electrons with their atomic nuclei and considered a rigid rotating molecule. The errors incurred by this treatment are minor as we shall show later. A more precise formulation would have been to write the rotational energy including explicitly the electronic potential and kinetic energy. In this case we have

$$H = \frac{1}{2}\sum_g \frac{N_g^2}{I_g} + \frac{1}{2m}\sum_g\sum_j (p_g)_j^2 + V(g, g', g'') \quad (\text{VI.9})$$

where  $N_g$  is a component of the nuclear angular momentum  $N$  resolved along the molecule fixed axis  $g$ ;  $I_g$  is the principal moment of inertia on the  $g$  axis,  $(p_g)_j$  is a component of the linear momentum of the  $j$ th electron resolved along the molecule fixed axis  $g$ ;  $V(g, g', g'')$  is the potential for the electronic motion and involves only relative co-ordinates of the particles. The total angular momentum,  $P$ , of such a

system of particles is a constant of the motion. Then instantaneously

$$\mathbf{P} = \mathbf{N} + \mathbf{L} \quad . \quad . \quad . \quad (VI.10)$$

The Hamiltonian of equation (VI.8), including the electronic magnetic energy (since it also depends upon  $L_g$ ) may now be rewritten, using equation VI.9), in the form:

$$\mathbf{H} = \mathbf{H}_r + \mathbf{H}_e + \mathbf{H}' + \mathbf{H}_m \quad . \quad . \quad . \quad (VI.11)$$

where

$$\mathbf{H}_r = \frac{1}{2} \sum_g \frac{\mathbf{P}_g^2}{I_g}$$

$$\mathbf{H}_e = \frac{1}{2m} \sum_g \sum_j (p_g)_j^2 + V(g, g', g'')$$

$$\mathbf{H}' = - \sum_g \frac{L_g \mathbf{P}_g}{I_g}$$

Terms in  $L_g^2/I_g$  have been neglected in comparison to  $\mathbf{H}'$ , since they are in first order independent of the rotational state of the molecule.

$\mathbf{H}_r$  corresponds to the usual pure rotation Hamiltonian and so in the usual representation in which  $\mathbf{P}^2 = J(J+1)\hbar^2$ ,  $\mathbf{P}_z = K\hbar$ , and  $\mathbf{P}_z = M\hbar$ , the matrix element for  $\mathbf{H}_r$  and  $\Phi_{Zg}$  are known.  $\mathbf{H}_e$  corresponds to the Hamiltonian for the usual problem of the electronic structure of a molecule at rest in a co-ordinate system  $g, g', g''$ . We will here assume that the problem of finding a representation in which  $\mathbf{H}_e$  is diagonal with respect to a lumped electronic quantum number  $n$  has been solved.  $\mathbf{H}'$  connects these two problems, since, though  $L_g$  has no elements diagonal in  $n$  in the ground electronic state (we assume a  $^1\Sigma$  electronic ground state),  $L_g$  does have matrix elements off-diagonal in  $n$ , and  $\mathbf{P}_g$  and  $\Phi_{Zg}$  have matrix elements in the rotational quantum numbers. The matrix of  $\mathbf{H}$  has then the form shown in Fig. 4.

The diagonal values of  $\mathbf{H}_e$  are taken as  $W_n^e$ . Since  $|W_n^e - W_0^e| \gg |(J, K | \mathbf{H}_r | J, K') - (J'', K'' | \mathbf{H}_r | J'', K''')|$ , i.e., the electronic levels are of much greater spacing than the rotational levels, the matrix elements of  $\mathbf{H}'$  and  $\mathbf{H}_m^e$  may be

diagonalized with respect to  $n$  in the usual approximate continued fraction form. For the ground electronic state ( $n = 0$ ), the corrected matrix elements are of the form:

$$(J, K, 0 | H' + H_m^e | J', K', 0)^{(1)} = \sum_{n, K''} \frac{(J, K, 0 | H' + H_m^e | J'', K'', n)(J'', K'', n | H' + H_m^e | J', K', 0)}{W_0^e - W_n^e} \quad (VI.12)$$

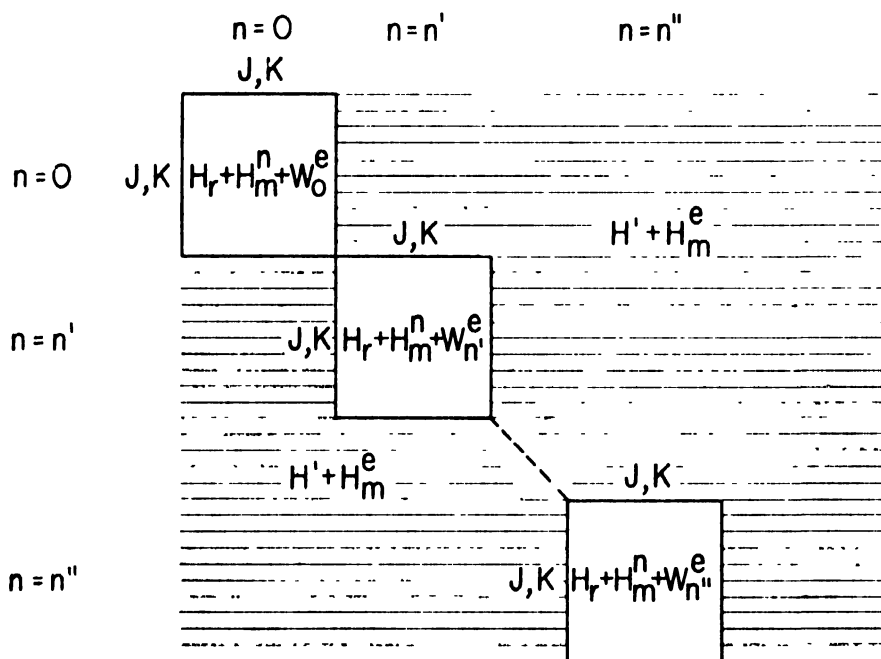

Fig. 4. Electronic-rotation energy matrix

In the original representation  $L_g$  depends only upon electronic quantum numbers  $n$ , and  $P_g$  depends only upon rotational quantum numbers, so the  $H'$  matrix elements are simply

$$(J, K, 0 | H' | J', K', n) = \sum_g (0 | L_g | n)(J, K | P_g | J', K') / I_g \quad (VI.13)$$

and the  $H_m^e$  matrix elements are simply

$$(J, K, 0 | H_m^e | J', K', n) = \frac{eB_z}{2mc} \sum_g (0 | L_g | n)(J, K | \Phi_{z,g} | J', K') \quad (VI.14)$$

Using the notation

$$A_{gg'} = \sum_{n \neq 0} \frac{(0|L_g|n)(n|L_{g'}|0)}{W_n^e - W_0^e} = A_{g'g}^*$$

equation (VI.12) may be expanded and the first order contributions of  $H'$  and  $H_m^e$  written separately as:

$$H^{(1)} = \sum_g \sum_{g'} \frac{A_{gg'} P_g P_{g'}}{I_g I_{g'}} \quad \text{(VI.15)}$$

$$H_m^{e(1)} = -\frac{eB_Z}{4mc} \sum_g \sum_{g'} \frac{A_{gg'} P_{g'} \Phi_{Zg} + A_{g'g} \Phi_{Zg} P_{g'}}{I_{g'}} \quad \text{(VI.16)}$$

We will return to the results expressed in equation (VI.15) in a later chapter. To consider the total magnetic perturbation, equation (VI.16) is added to equation (VI.7) which expresses the energy of interaction of the nuclear rotational magnetic moment with the static field  $B$ .

$$H_m = -\frac{1}{2} B_Z \sum_g \sum_{g'} [G_{gg'} P_{g'} \Phi_{Zg} + G_{gg'}^* \Phi_{Zg} P_{g'}] = -B_Z \mu_Z \quad \text{(VI.17)}$$

where

$$G_{gg'} = G_{gg'}^n + G_{gg'}^e$$

and

$$G_{gg'}^e = \frac{e}{2mc} \frac{A_{gg'}}{I_{g'}}$$

The form of equation (VI.17) is so chosen since the  $G_{gg'}$ 's represent a rotational magnetic moment  $g$ -factor tensor relating the rotational magnetic moment of the molecule to the components of angular momentum in the molecule fixed axes.

Using the known direction cosine and angular momentum matrix elements (Table 1, equation (I.4), Chapter I) the magnetic moment,  $\mu_Z$ , expressed in equation (VI.17) may be expanded. These results are presented in Appendix III.

In general then for any molecule in which the rotational Hamiltonian is not diagonal for the representation used to evaluate the magnetic energy matrix in Appendix III, a certain transformation  $XT$  must be applied to make it diagonal. We have seen in Chapter II how this transformation is determined.

This same transformation must be applied to  $H_m$  to evaluate the magnetic energy.  $H_m$  will still have off-diagonal elements even under the transformation  $XT$  and, precisely, these would have to be reduced to the diagonal to arrive at a completely accurate value for the change in the rotational energy due to the presence of the static magnetic field.

Some very adequate approximations to this whole process present themselves.

We are interested in the diagonal elements of  $T^{-1}X^{-1}H_mXT$ . From the matrix of  $H_m$  it is evident that the off-diagonal elements of the  $G$  tensor contribute in second order. The  $(J, K|H_m|J, K)$  elements involving  $G_{gg'}$ ,  $g \neq g'$ , are proportional to  $K$  and hence are removed from the diagonal by the symmetrizing transformation  $X$  and contribute in second and higher order only. The transformation  $T$  has only real elements of the form  $(J, K|J, K \pm 2n)$  and hence the  $(J, K|J, K \pm 1)$  and the imaginary  $(J, K|J, K \pm 2)$  elements of  $H_m$  which depend only upon the non-diagonal  $G$  elements yield no diagonal contribution to the transformed energy. Thus to first order we may simplify  $H_m$  to

$$H_m^{(1)} = -B_Z \sum_g G_{gg} P_g \Phi_{Zg} \quad . \quad . \quad (VI.18)$$

Further, since  $T$  is diagonal in  $J$ , the elements of  $\Phi_{Zg}$  off-diagonal in  $J$  will yield no first order energy contribution. But the elements of  $\Phi_{Zg}$  diagonal in  $J$  are simply related to  $P_g$  as

$$\Phi_{Zg} = \frac{MP_g}{J(J+1)\hbar} \quad . \quad . \quad (VI.19)$$

Hence we may write

$$H_m^{(1)} = -\frac{B_Z M}{J(J+1)\hbar} \sum_g G_{gg} P_g^2 \quad . \quad (VI.20)$$

In a representation in which  $H_r$  is diagonal with values  $W$  we have the diagonal elements of the magnetic energy as:

$$\langle T^{-1}X^{-1}H_m^{(1)}XT \rangle = -\frac{B_Z M}{J(J+1)\hbar} \sum_g G_{gg} \langle P_g^2 \rangle \quad . \quad (VI.21)$$

where, as has been shown in Chapter II,

$$\frac{\partial W}{\partial \bar{g}} = \frac{2\pi}{\hbar} \langle P_g^2 \rangle$$

For symmetric top molecules with  $z$  as the symmetry axis,

$$G_{yy} = G_{xx}$$

and

$$H_m^{(1)} = - B_z M \hbar \left\{ G_{xx} + (G_{zz} - G_{xx}) \frac{K^2}{J(J+1)} \right\}. \quad (\text{VI.22})$$

This equation is valid for linear molecules in the ground bending vibrational state if  $K$  is set equal to zero.

It is evident from equation (VI.21) that the application of a magnetic field  $B$  lifts the spatial  $M$ -degeneracy of the rotational levels. However, the absorption frequency for  $\pi$  or  $\Delta M = 0$  transitions ( $B_z$  along the radiation electric field vector) will be changed by an amount measured by the difference in the coefficients of  $MB_z$  for the two states involved. For  $\sigma$ , or  $\Delta M = \pm 1$  transitions ( $B_z$  perpendicular to the radiation electric field) the shift of the  $\pi$  lines will split by an amount measured by the magnitude of the  $B_z M$  coefficient of the upper level.

## CHAPTER VII

### INTERACTION OF ROTATIONAL AND ELECTRONIC STATES

IN Chapter VI, equation (VI.15), we have developed an expression for the contribution to the rotational energy by the molecular electrons. In effect this contribution may be taken as a correction to the molecular reciprocal moments of inertia due to the presence of electrons. Naively, the reciprocal moments of inertia for a molecule would be calculated using atomic rather than nuclear masses to include the effect of the electrons. That this is only a zero order correction may be seen by realizing that the electrons are neither concentrated at their corresponding nuclei, nor are they free to precess unhindered about their nuclear centres, and hence their spatial distribution and motion must be taken into account.

The correction to the molecular rotational energy, calculated with nuclear masses then is, from equation (VI.15), Chapter VI,

$$H' = - \sum_g \sum_{g'} \frac{A_{gg'} P_g P_{g'}}{I_g I_{g'}} \quad . \quad . \quad (VII.1)$$

If  $H_r$  is diagonalized by the transformation  $XT$  we are interested in the diagonal value of  $T^{-1}X^{-1}H'XT$ . Using arguments similar to those used in Chapter VI to establish equation (VI.18), we may show that the diagonal terms of equation (VII.1) are given by:

$$\begin{aligned} \langle T^{-1}X^{-1}HXT \rangle &= - \sum_g \frac{A_{gg}}{I_{gg}^2} \langle P_g^2 \rangle \\ &= \frac{mc}{e} \sum_g \frac{G_{gg}^e}{I_{gg}} \langle P_g^2 \rangle \quad . \quad (VII.2) \end{aligned}$$

Since the diagonalized values of  $H_r$  in the absence of  $H'$  are  $W_R = \frac{2\pi}{\hbar} \sum_g \bar{g} \langle P_g^2 \rangle$ , equation (VII.2) states that the effect of the electrons is to add to the nuclear reciprocal moment a term such as to give an effective reciprocal moment

$$\bar{g}_{\text{eff}} = \bar{g} + \frac{mc}{e} \frac{G_{gg}^e}{I_{gg}} \frac{\hbar}{2\pi} \quad . \quad . \quad (\text{VII.3})$$

By definition

$$\bar{g}_{\text{eff}} = \bar{g} + \frac{mc}{e} \frac{G_{gg}}{I_{gg}} \frac{\hbar}{2\pi} - \frac{mc}{e} \frac{G_{gg}^n}{I_{gg}} \frac{\hbar}{2\pi} \quad . \quad . \quad (\text{VII.4})$$

But 
$$\frac{2mc}{e} I_g G_{gg}^n = \sum_k Z_k m [(g')_k^2 + (g'')_k^2] \quad . \quad . \quad (\text{VII.5})$$

with  $Z_k$  the atomic number of the  $k$ th nucleus and  $(g)_k$  the co-ordinates of the  $k$ th nucleus.

This is just the moment of inertia of the electrons considered concentrated at their respective nuclear centres. The moment of inertia calculated with atomic rather than nuclear masses is:

$$I_{gg}^{\text{atom}} = I_{gg}^{\text{nuc}} + I_{gg}^{\text{elec}} \quad . \quad . \quad (\text{VI.6})$$

This allows equation (VII.4) to be reduced to the form

$$\bar{g}_{\text{eff}} = \bar{g}_{\text{atom}} + \frac{mc}{e} \frac{G_{gg}}{I_{gg}} \frac{\hbar}{2\pi} \quad . \quad . \quad (\text{VII.7})$$

The correction to the reciprocal moment of inertia of a molecule calculated in terms of atomic masses will thus be given by the diagonal elements of the total rotational magnetic moment tensor,  $G$ , as shown in equation (VII.7), to yield the effective, or observed, reciprocal moment of inertia  $\bar{g}_{\text{eff}}$ .

## CHAPTER VIII

### LINE SHAPES AND INTENSITIES

A MOLECULE with an electric or magnetic moment  $\mu$  in the presence of, respectively, an electric or magnetic field,  $F$ , has a term added to its energy of the form:

$$H_F = -\mu \cdot F \quad . \quad . \quad . \quad (VIII.1)$$

When the field vector  $F$  is time dependent such an interaction of a molecule with a field can give rise to changes in the rotational state of the molecule. We will thus consider equation (VIII.1) to determine the frequency dependence and intensity of this interaction of a molecule with a time varying field.

To obtain the simplicity of the specific we will consider an alternating electric field  $\epsilon_z(t)$  along the space fixed axis  $Z$ , interacting with the electric dipole moment of a molecule. The consideration of the general field and orientations, however, would follow our analysis with no purely logical difficulty.

The most direct method of achieving the desired result is through the use of the quantum mechanical density matrix  $\rho_{nm}$ . (1). We will need to use some important properties of the density matrix.

(1) The contracted matrix notation will be used in this chapter, i.e.,  $\rho_{nm} \equiv (n|\rho|m)$ , where  $n$  and  $m$  signify the totality of relevant quantum numbers.

Like its classical analogue,  $\rho_{nn}$  is the probability that a system chosen at random from an ensemble will be found in state  $n$ . Hence

$$\sum_l \rho_{ll} = 1 \quad . \quad . \quad . \quad (VIII.2)$$

The mean value of an observable is the diagonal sum of the matrix product of the observable with  $\rho$ .

$$\bar{O} = \sum_l \bar{O}_{ll} = \sum_m \sum_l O_{ml} \rho_{lm} \quad . \quad . \quad . \quad (VIII.3)$$

Classically this summation is replaced by an integration, it will be remembered.

The density matrix obeys the usual equation of motion.

$$\dot{\rho}_{mn} = -\frac{i}{\hbar} \sum_l (H_{ml} \rho_{ln} - \rho_{ml} H_{ln}) \quad . \quad (\text{VIII.4})$$

A system of molecules, in thermal equilibrium, with a time-dependent Hamiltonian evidently has a density matrix given by

$$[\rho_0(t)]_{nm} = \frac{\left[ e^{-\frac{H(t)}{kT}} \right]_{nm}}{\sum_l \left[ e^{-\frac{H(t)}{kT}} \right]_{ll}} \quad . \quad (\text{VIII.5})$$

If H is time-independent, and in a diagonal representation, the density matrix in thermal equilibrium is given by the usual Boltzmann form:

$$[\rho_0]_{nm} = \frac{e^{-\frac{W_n}{kT}}}{\sum_l e^{-\frac{W_l}{kT}}} \delta_{nm} \quad . \quad (\text{VIII.6})$$

where

$$\delta_{nm} = \begin{cases} 0 & m \neq n \\ 1 & m = n \end{cases}$$

The mean value of the molecular electric dipole moment is written by equation (VIII.3) as:

$$\bar{\mu}_Z(t) = \sum_m \sum_l (\mu_Z)_{ml} \rho_{lm}(t) \quad . \quad (\text{VIII.7})$$

In the presence of an electric field

$$\varepsilon_Z(t) = \varepsilon_Z \cos \omega t = \text{Re}[\varepsilon_Z e^{-i\omega t}] \quad . \quad (\text{VIII.8})$$

with Re meaning “real part of,” we have by definition of the molecular susceptibility:

$$\bar{\mu}_Z(t) = \text{Re}[\chi \varepsilon_Z e^{-i\omega t}] = \frac{1}{2} [\chi \varepsilon_Z e^{-i\omega t} + \chi^* \varepsilon_Z e^{i\omega t}] \quad . \quad (\text{VIII.9})$$

where  $\chi^*$  is the complex conjugate of  $\chi$ .

## CHAPTER VIII

### LINE SHAPES AND INTENSITIES

A MOLECULE with an electric or magnetic moment  $\mu$  in the presence of, respectively, an electric or magnetic field,  $F$ , has a term added to its energy of the form:

$$H_F = -\mu \cdot F \quad . \quad . \quad (VIII.1)$$

When the field vector  $F$  is time dependent such an interaction of a molecule with a field can give rise to changes in the rotational state of the molecule. We will thus consider equation (VIII.1) to determine the frequency dependence and intensity of this interaction of a molecule with a time varying field.

To obtain the simplicity of the specific we will consider an alternating electric field  $\varepsilon_Z(t)$  along the space fixed axis  $Z$ , interacting with the electric dipole moment of a molecule. The consideration of the general field and orientations, however, would follow our analysis with no purely logical difficulty.

The most direct method of achieving the desired result is through the use of the quantum mechanical density matrix  $\rho_{nm}$ . (1). We will need to use some important properties of the density matrix.

(1) The contracted matrix notation will be used in this chapter, i.e.,  $\rho_{nm} \equiv (n|\rho|m)$ , where  $n$  and  $m$  signify the totality of relevant quantum numbers.

Like its classical analogue,  $\rho_{nn}$  is the probability that a system chosen at random from an ensemble will be found in state  $n$ . Hence

$$\sum_l \rho_{ll} = 1 \quad . \quad . \quad (VIII.2)$$

The mean value of an observable is the diagonal sum of the matrix product of the observable with  $\rho$ .

$$\bar{O} = \sum_l \bar{O}_{ll} = \sum_m \sum_l O_{ml} \rho_{lm} \quad . \quad . \quad (VIII.3)$$

Classically this summation is replaced by an integration, it will be remembered.

The density matrix obeys the usual equation of motion.

$$\dot{\rho}_{mn} = -\frac{i}{\hbar} \sum_l (H_{ml} \rho_{ln} - \rho_{ml} H_{ln}) \quad . \quad (\text{VIII.4})$$

A system of molecules, in thermal equilibrium, with a time-dependent Hamiltonian evidently has a density matrix given by

$$[\rho_0(t)]_{nm} = \frac{\left[ e^{-\frac{H(t)}{kT}} \right]_{nm}}{\sum_l \left[ e^{-\frac{H(t)}{kT}} \right]_{ll}} \quad . \quad (\text{VIII.5})$$

If H is time-independent, and in a diagonal representation, the density matrix in thermal equilibrium is given by the usual Boltzmann form:

$$[\rho_0]_{nm} = \frac{e^{-\frac{W_n}{kT}}}{\sum_l e^{-\frac{W_l}{kT}}} \delta_{nm} \quad . \quad (\text{VIII.6})$$

where

$$\delta_{nm} = \begin{cases} 0 & m \neq n \\ 1 & m = n \end{cases}$$

The mean value of the molecular electric dipole moment is written by equation (VIII.3) as:

$$\bar{\mu}_Z(t) = \sum_m \sum_l (\mu_Z)_{ml} \rho_{lm}(t) \quad . \quad (\text{VIII.7})$$

In the presence of an electric field

$$\epsilon_Z(t) = \epsilon_Z \cos \omega t = \text{Re}[\epsilon_Z e^{-i\omega t}] \quad . \quad (\text{VIII.8})$$

with Re meaning "real part of," we have by definition of the molecular susceptibility:

$$\bar{\mu}_Z(t) = \text{Re}[\chi \epsilon_Z e^{-i\omega t}] = \frac{1}{2} [\chi \epsilon_Z e^{-i\omega t} + \chi^* \epsilon_Z e^{i\omega t}] \quad . \quad (\text{VIII.9})$$

where  $\chi^*$  is the complex conjugate of  $\chi$ .

It will be remembered that the power attenuation of a plane electromagnetic wave propagating in the X direction through gas of N molecules per cubic centimetre, is given as

$$P(X) = P_0 e^{-\gamma X} \quad \text{(VIII.10)}$$

where

$$\gamma = \frac{4\pi\omega N}{c} \text{Im}(\chi)$$

The following calculations will then lead to an expression for  $\gamma$ , the absorption coefficient, which will display the magnitude and frequency dependence of the absorption of an electromagnetic wave by a gas.

Hard collisions will be used as a mechanism to restore thermal equilibrium. This means that with a collision occurring previously at a time  $t_0 = t - \theta$ ,  $\rho$  will start with an initial condition of

$$[\rho_0(t_0)]_{nm} = \frac{\left[ e^{-\frac{H(t_0)}{kT}} \right]_{nm}}{\sum_l \left[ e^{-\frac{H(t_0)}{kT}} \right]_{ll}} \quad \text{(VIII.11)}$$

and will develop with time as a function  $\rho(t, t_0)$ . The Hamiltonian will be simply

$$H(t) = H_0 - \mu_Z \mathcal{E}_Z \cos \omega t = H_0 + V \cos \omega t \quad \text{(VIII.12)}$$

since the collision is assumed to be hard, or the interaction between molecules is zero for infinitesimal separations. The consideration of the actual form of the intermolecular potential may be carried out, but this results in no essential modification of our results. The specific changes are minor and are of so little general application that it is well to dispense with the additional complication.

The density matrix will thus be a function of the initial time  $t_0 = t - \theta$ , and  $t$  as  $\rho(t, t_0)$  and thus to determine  $\rho(t)$  for equation (VIII.7),  $\rho(t, t_0)$  must be integrated over all initial conditions. The probability that a collision occurred during a previous time interval  $t - \theta, t - \theta - d\theta$  is  $\tau^{-1} e^{-\frac{t-\theta}{\tau}} d\theta$ , since random collisions having a mean time interval  $\tau$  are assumed.

$$\rho(t) = \int_0^\infty \rho(t, t - \theta) \tau^{-1} e^{-\frac{\theta}{\tau}} d\theta \quad . \quad (\text{VIII.13})$$

Differentiating partially with respect to time gives

$$\begin{aligned} \frac{\partial}{\partial t} \rho(t) &= \int_0^\infty \left[ \frac{\partial}{\partial t} \rho(t, t_0) \right]_{t_0 = t - \theta} \tau^{-1} e^{-\frac{\theta}{\tau}} d\theta \\ &- \int_0^\infty \frac{\partial}{\partial \theta} \rho(t, t - \theta) \tau^{-1} e^{-\frac{\theta}{\tau}} d\theta \quad . \quad (\text{VIII.14}) \end{aligned}$$

The second term on the right in equation (VIII.14) arises since  $t_0$  is a function of  $t$  through  $\theta$ . The density matrix develops with time from a given initial time  $t_0$  as given by equation (VIII.4). Since  $H(t)$  is independent of  $\theta$ , by using equation (VIII.13) the first term on the right-hand side of equation (VIII.14) may be reduced to:

$$-\frac{i}{\hbar} [H(t)\rho(t) - \rho(t)H(t)]$$

The second term on the right of equation (VIII.14) is integrated by parts to yield

$$-\tau^{-1}[\rho(t) - \rho_0(t)]$$

where

$$\rho_0(t) = \rho(t, t_0 = t)$$

The equation of motion for  $\rho(t, t_0)$  averaged over  $t_0$  may be written in terms of a parameter measuring the instantaneous deviation of this average from thermal equilibrium as

$$\begin{aligned} D(t) &= \rho(t) - \rho_0(t) \\ \frac{\partial D(t)}{\partial t} &= \frac{\partial \rho(t)}{\partial t} - \frac{\partial \rho_0(t)}{\partial t} \end{aligned}$$

The quantity  $\rho_0(t)$  is of the form  $e^{-\frac{H(t)}{kT}}$ , since in equation (VIII.20) the denominator is shown to be a constant. Then  $H(t)\rho_0(t) - \rho_0(t)H(t) = 0$ . This follows from expanding the exponential into an absolutely converging power series in  $H(t)$ . Since  $H(t)$  must commute with itself and with powers

of itself,  $H(t)$  must commute with each term of the series, i.e.,  $H(t)$  must commute with  $\rho_0(t)$ . The differential equation satisfied by  $D(t)$  is given as:

$$\begin{aligned} \frac{\partial}{\partial t} D(t) = & -\frac{i}{\hbar} [H(t)D(t) - D(t)H(t)] \\ & - \tau^{-1}D(t) + \frac{\partial}{\partial t} \rho_0(t) . \end{aligned} \quad (\text{VIII.15})$$

In a representation in which  $H_0$  is diagonal with characteristic values  $W$  equation (VIII.15) may be written as:

$$\begin{aligned} \left( \frac{\partial}{\partial t} + i\omega_{mn} + \tau^{-1} \right) D_{mn}(t) = & -\frac{\partial}{\partial t} [\rho_0(t)]_{mn} \\ & - \frac{i}{\hbar} \sum_l [V_{ml}D_{ln}(t) - D_{ml}(t)V_{ln}] \cos \omega t \end{aligned} \quad (\text{VIII.16})$$

where  $\hbar\omega_{mn} = W_m - W_n$

Consider now the form of  $[\rho_0(t)]_{mn}$

$$[\rho_0(t)]_{mn} = \frac{\left[ e^{-\frac{H(t)}{kT}} \right]_{mn}}{\sum_l \left[ e^{-\frac{H(t)}{kT}} \right]_{ll}} . \quad (\text{VIII.17})$$

Since, for practical reasons,  $V$  must be small with respect to  $kT$ , the numerator may be expanded as:

$$\begin{aligned} \left[ e^{-\frac{H(t)}{kT}} \right]_{mn} = & \left[ e^{-\frac{H_0}{kT}} \right]_{mn} \\ & - \sum_l \left\{ \left[ e^{-\frac{H_0}{kT}} \right]_{ml} V_{lm} + V_{ml} \left[ e^{-\frac{H_0}{kT}} \right]_{ln} \right\} \frac{\cos \omega t}{2kT} . \end{aligned} \quad (\text{VIII.18})$$

The matrix elements of  $e^{-\frac{H_0}{kT}}$  are evaluated by expanding  $e^{-\frac{H_0}{kT}}$  in an absolutely converging power series in  $H_0/kT$ . If  $H_0$  is diagonal with values  $W$  then all powers of  $H_0$  are

diagonal and equal to  $W$  to the same power. The relation  $\left[ e^{-\frac{H_0}{kT}} \right]_{mn} = e^{-\frac{W_m}{kT}} \delta_{mn}$  follows immediately.

The symmetrized form is used in the usual fashion to insure that  $\rho_0(t)$  is hermitian, for  $V$  will not commute with  $\left[ e^{-\frac{H_0}{kT}} \right]$ . Since  $H_0$  is diagonal equation (VIII.18) reduces to:

$$\left[ e^{-\frac{H(t)}{kT}} \right]_{mn} = e^{-\frac{W_m}{kT}} \delta_{mn} = \left[ e^{-\frac{W_m}{kT}} \quad ; \quad e^{-\frac{W_n}{kT}} \right] V_{mn} \cos \omega t \quad (VIII.19)$$

In a similar fashion the denominator of equation (VIII.17) may be expanded as:

$$\sum_l e^{-\frac{W_l}{kT}} + \sum_l e^{-\frac{W_l}{kT}} V_{ll} \cos \omega t = \sum_l e^{-\frac{W_l}{kT}} \quad (VIII.20)$$

The equality results from the fact that  $V_{ll} = (\mu_z)_{ll} \epsilon_z = 0$ , since as argued in Chapter V in a representation in which  $H_0$  is diagonal, the symmetrized form of  $\mu_z$ , i.e.,  $X^{-1} \mu_z X$ , has no diagonal matrix elements.

These results may be written as

$$[\rho_0(t)]_{mn} = \rho_{0m} \delta_{mn} + (\rho_{0m} + \rho_{0n}) \frac{V_{mn}}{2kT} \cos \omega t \quad (VIII.21)$$

where

$$\rho_{0m} = \frac{e^{-\frac{W_m}{kT}}}{\sum_l e^{-\frac{W_l}{kT}}}$$

If only a weak radiation field is considered then  $D$  will differ little from zero and so the terms such as  $V_{ml} D_{ln}$  may be ignored. The effect of these terms will be considered later.

In this case the equation of motion for  $D(t)$  becomes

$$\left[ \frac{\partial}{\partial t} + i\omega_{mn} + \tau^{-1} \right] D_{mn}(t) = \frac{\omega}{2kT} (\rho_{0m} + \rho_{0n}) V_{mn} \sin \omega t \quad (VIII.22)$$

The steady state solution to this equation is:

$$D_{mn}(t) = \frac{V_{mn}}{4kT} (\rho_{0m} + \rho_{0n}) \left( \frac{\omega}{\omega - \omega_{mn} + i\tau^{-1}} e^{-i\omega t} + \frac{\omega}{\omega + \omega_{mn} - i\tau^{-1}} e^{i\omega t} \right) \quad (\text{VIII.23})$$

Since  $\rho_{mn}(t) = [\rho_0(t)]_{mn} + D_{mn}(t)$

equation (VIII.7) may be written as:

$$\begin{aligned} \mu_Z(t) = \sum_m \sum_n (\mu_Z)_{mn} (\mu_Z)_{nm} \epsilon_Z \frac{\rho_{0m} + \rho_{0n}}{4kT} \\ \times \left[ \left( 1 - \frac{\omega}{\omega - \omega_{mn} + i\tau^{-1}} \right) e^{-i\omega t} + \left( 1 - \frac{\omega}{\omega + \omega_{mn} - i\tau^{-1}} \right) e^{i\omega t} \right] \quad (\text{VIII.24}) \end{aligned}$$

Since  $\mu_Z$  must be hermitian,  $(\mu_Z)_{mn} = (\mu_Z)_{nm}^*$  so  $(\mu_Z)_{mn}(\mu_Z)_{nm} = |(\mu_Z)_{mn}|^2$ . The molecular susceptibility as defined by equation (VIII.9) is thus identified as:

$$\chi = \sum_m \sum_n \frac{|(\mu_Z)_{mn}|^2}{2kT} (\rho_{0m} + \rho_{0n}) \left( 1 - \frac{\omega}{\omega - \omega_{mn} + i\tau^{-1}} \right) \quad (\text{VIII.25})$$

The two bracketed factors in equation (VIII.24) are obviously not complex conjugates, but the form  $\chi + \chi^*$  is achieved by pairing  $mn$  and  $nm$  terms in summation.

The final evaluation of the absorption coefficient yields:

$$\gamma = \frac{2\pi\omega^2 N}{ckT} \sum_m \sum_n |(\mu_Z)_{mn}|^2 \frac{\tau^{-1}}{(\omega - \omega_{mn})^2 + \tau^{-2}} (\rho_{0m} + \rho_{0n}) \quad (\text{VIII.26})$$

The form of equation (VIII.26) may be changed to make it more manageable. The equation may be made symmetric in  $m$  and  $n$  by grouping terms in  $mn$  and  $nm$  since  $\omega_{mn} = -\omega_{nm}$ .

Only a single index need be summed by called  $\omega_{mn} = \omega_{nm} = \omega_i > 0$ . The energy  $W_m$  which has a rotational quantum number  $J$  will be  $(2J + 1)$ -degenerate since  $W_m$  is independent of  $M$ , the projection of  $J$  on the space fixed  $Z$  axis. If there exist nuclei off a symmetry axis in the molecule the effective degeneracy of the  $i$ th transition will be increased by the nuclear spin statistical factor  $g_i$ . With  $|\omega_i|$  taken to include all the degenerate values of  $\omega_i$  the summations in equation (VIII.27) may be replaced by one over the  $M$ -degeneracy for  $\mu_Z^2$  and one over  $i$ , to account for the contributions from energetically distinct states.

$$\gamma = \sum_i \frac{2\pi\omega^2 N g_i}{ckT} \left[ \frac{\tau^{-1}}{(\omega - \omega_i)^2 + \tau^{-2}} + \frac{\tau^{-1}}{(\omega + \omega_i)^2 + \tau^{-2}} \right] \times \frac{e^{-\frac{W_i}{kT}} \left( 1 + e^{-\frac{h\omega_i}{kT}} \right)}{\sum_i (2J + 1) g_i e^{-\frac{W_i}{kT}}} \times [\sum_M |(\mu_Z)_M|^2]_i \quad \text{(VIII.27)}$$

In microwave spectroscopy the non-degenerate absorption frequencies,  $\omega_i$ , will differ greatly compared to  $\tau^{-1}$ , hence  $\gamma$  need only be taken as being due to the transition nearest resonance. Further, microwave absorptions will have  $h\omega \ll kT$  and so  $\gamma$  may be finally simplified to

$$\gamma \cong \gamma_i = \frac{4\pi\omega^2 N}{ckT} \left[ \frac{\tau^{-1}}{(\omega - \omega_i)^2 + \tau^{-2}} \right] \times \frac{\bar{W}_i}{g_i e^{-\frac{W_i}{kT}}} \times \frac{W_i}{\sum_i (2J + 1) g_i e^{-\frac{W_i}{kT}}} [\sum_M |(\mu_Z)_M|^2]_i \quad \text{(VIII.28)}$$

where  $\bar{W}_i = \frac{1}{2} [W_{\text{initial}} + W_{\text{final}}]$

Most of the terms in equation (VIII.29) are self explanatory. The mean free time,  $\tau$ , should be determinable from viscosity data, though actual measurements of rotational spectra at room temperature show this spectroscopic value to be smaller by as much as a factor of 15. The difference between  $\tau_{\text{obs}}$  and

$\tau_{\text{calc}}$  may be accounted for by considering the actual form of the energy of interaction between colliding molecules, instead of assuming hard collisions as was done above.  $W_i$  is the average of the initial and final state energies in an absorption transition and  $\sum_l (2J + 1) g_l e^{-\frac{W_l}{kT}}$  is the familiar partition sum. We must consider further the form of the dipole moment term.

The dipole moment factor may be written in terms of the components of the molecular dipole moment along the gyrating molecule-fixed axes ( $g - x, y, z$ ) and the direction cosines. In a representation in which  $\mathbf{P}, \mathbf{P}_z,$  and  $\mathbf{P}_Z$  are diagonal the direction cosine matrix elements are given in Table 1. In a representation in which  $H_r$  is diagonal they are given as  $\mathbf{T}^{-1}\mathbf{X}^{-1}\Phi_{Fg}\mathbf{X}\mathbf{T}$ , where  $\mathbf{X}\mathbf{T}$  is the diagonalizing transformation of Chapter II.

$$\mu_F = \sum_g \mu_g \mathbf{T}^{-1}\mathbf{X}^{-1}\Phi_{Fg}\mathbf{X}\mathbf{T} \quad . \quad (\text{VIII.29})$$

and from the properties of  $\mathbf{X}^{-1}\Phi_{Fg}\mathbf{X}$  it is readily shown that

$$|\mu_F|^2 = \mu_F \mu_F^* = \sum_g \mu_g^2 |\mathbf{T}^{-1}\mathbf{X}^{-1}\Phi_{Fg}\mathbf{X}\mathbf{T}|^2 \quad . \quad (\text{VIII.30})$$

As it may be seen from the degeneracy of the space fixed axes, or from direct calculation, the summation over  $F$  is accomplished by multiplying the total contribution of any  $F$  by 3.

$$\sum_F \sum_{M, M'} |\mu_F|^2 = 3 \sum_M \sum_g \mu_g^2 |\mathbf{T}^{-1}\mathbf{X}^{-1}\Phi_{Zg}\mathbf{X}\mathbf{T}|^2 \quad . \quad (\text{VIII.31})$$

The summation over  $M$  may be performed at any time since  $\mathbf{X}\mathbf{T}$  is diagonal in  $M$ . The work implied by equation (VIII.31) is, of course, great in any general asymmetric top. However, as we have seen tables are available which give the total line strength,

$$[\lambda_g]_i = [3 \sum_M |\mathbf{T}^{-1}\mathbf{X}^{-1}\Phi_{Zg}\mathbf{X}\mathbf{T}|^2]_i \quad . \quad (\text{VIII.32})$$

Interpolation in these tables will give  $\lambda_g$  for any desired  $\kappa$  to the practical accuracy necessary. Thus we may use tabulated values for

$$\sum_M |(\mu_Z)_M|^2 = \frac{1}{3} \sum_{M M'} \sum_F |(\mu_F)_{M M'}|^2 = \frac{1}{3} \sum_g \mu_g^2 [\lambda_g(\kappa)]_i \quad . \quad . \quad (\text{VIII.33})$$

In establishing equation (VIII.22), the radiation field was assumed weak so that terms such as  $V_{ml}D_{ln}$  could be ignored. If these terms are considered to a magnitude so that  $V$  is small compared with internal molecular potentials then a solution to the equation of motion for  $D_{mn}(t)$  takes the form of  $R_{mn} + P_{mn}^{(+)}e^{-i\omega t} + P_{mn}^{(-)}e^{i\omega t}$ , i.e., no induced dipole moment varying as  $e^{+i2\omega t}$  exists. The resulting equations for  $R$ , and  $P^{(+)}$  may be solved readily in the neighbourhood of a particular resonance  $\omega_j = \omega_{mn} > 0$  since the matrix elements  $R_{mm}$ ,  $R_{nn}$ , and  $P_{mn}^{(\pm)}$  need be considered. The final result is to modify equation (VIII.28) by setting

$$\tau^{-1} \sum_M [ |(\mu_Z)_M|^2 ]_i \frac{\tau^{-1} |(\mu_Z)_M|^2}{(\omega - \omega_j)^2 + \tau^{-2}} = \sum_M \frac{\tau^{-1} |(\mu_Z)_M|^2}{(\omega - \omega_j)^2 + \tau^{-2} + \frac{|(\mu_Z)_M|^2 \epsilon_Z^2}{\hbar^2}} \quad (\text{VIII.34})$$

Thus as  $|(\mu_Z)_M| \epsilon_Z / \hbar$  becomes comparable with  $\tau^{-1}$  the line begins to broaden and the absorption coefficient decreases. This saturation is  $M$ -dependent in the sense that those transitions between  $M$  states having the largest value of  $\mu_F$  will saturate first. The saturation arises in fact from the presence of the time independent terms  $R_{mm}$  and  $R_{nn}$  in the expression for  $D_{mn}(t)$  which signify a permanent deviation from thermal equilibrium, i.e., the radiation field tends to equate the population density of states  $m$  and  $n$  and hence to decrease the difference between absorption transitions ( $\omega_{mn} > 0$ ) and emission transitions ( $\omega_{nm}$ ).

Inspection of the properties of the direction cosine matrix elements allows some general statements to be made.

First, electric dipole transitions have finite intensities only for changes in the total angular momentum  $J$  of  $\pm 1$  or  $0$ , since the direction cosines have only this type element. A molecule with a dipole moment along the  $a$  axis (axis of least inertia) would have a  $z$  axis dipole moment in a (I) representation (which leads in the limit to prolate symmetric rotors). Since  $\Phi_{Fz}$  has only (K|K) elements and the diagonalizing transformation  $XT$  leaves it with no elements diagonal in  $\tau$

and with only all even or all odd  $K$  matrix elements, the oddness or evenness of the prolate top  $K(K_{-1})$  must remain unchanged and that of  $K_{+1}$  must change for a finite transition probability.

Similarly, for a dipole moment on the  $c$  axis (the  $z$  axis in a (III) representation)  $K_{+1}$  must not change evenness or oddness, but  $K_{-1}$  must do so. And finally for a dipole moment on the  $b$  axis (the  $z$  axis in a (II) representation) both  $K_{+1}$  and  $K_{-1}$  must change evenness or oddness. Since a symmetric top, by symmetry, may have a dipole moment only along the  $z$ , or symmetry axis, the familiar selection rule  $\Delta K = 0$  is required. Note, however, that our above arguments allow transitions between the degenerate  $K$  levels, i.e.,  $\omega_i = 0$ . This fact allows symmetric tops to have a non-resonant absorption which results when  $\omega_i = 0$  is inserted in equation (VIII.27). The non-resonant absorption may be reduced readily to the simple form:

$$\gamma_{\text{non-resonant}} = \frac{4\pi\omega^2 N \mu^2}{3ckT} \frac{\tau^{-1}}{\omega^2 + \tau^{-2}} \quad \text{(VIII.35)}$$

The resonant absorptions in linear molecules will have the selection rule  $\Delta J = \pm 1$ . In this case, equation (VIII.29) reduces to

$$\gamma_i = \frac{2\pi N h \omega^3 \mu^2}{3ck^2 T^2} \frac{\tau^{-1}}{(\omega - \omega_i)^2 + \tau^{-2}} e^{-\frac{hbJ(J+1)}{kT}} \quad \text{(VIII.36)}$$

It should be observed that equations (VIII.27) and (VIII.36) give the total intensity of a transition in the absence of fine structure splitting due to nuclear quadrupole effect, Stark effect, and Zeeman effect. The relative intensity for the components for the quadrupole effect have been given in Chapter IV, while the relative intensities of the Stark and Zeeman components are given by the squares of the  $M$ -dependent factors of the appropriate direction cosine matrix elements.

## CHAPTER IX

### UNIQUE MICROWAVE TRANSITIONS

#### *A. Oxygen (O<sub>2</sub>)*

MOLECULAR oxygen is diatomic, and in a  $^3\Sigma$  electronic ground state, having  $1\hbar$  of uncompensated spin angular momentum and zero electronic orbital angular momentum. The magnetic moment of two Bohr magnetons associated with this spin angular momentum gives the molecule a permanent magnetic moment. The oxygen molecule for this reason exhibits its well-known paramagnetism, and is capable of interacting with an electromagnetic radiation field. The addition of the spin angular momentum  $P_S = \hbar$  to the nuclear rotational angular momentum, yields a resultant angular momentum  $P$  of

$$|P| = |P_N| \pm |P_S|, |P_N|$$

This gives rise to a spin-triplet structure for the spin-rotational energy levels, which is of microwave interest.

The part of the Hamiltonian of interest for the microwave region will consist of three contributions, the nuclear rotational energy, the magnetic energy, resulting from the interaction of the two uncompensated spins, and the magnetic energy resulting from the interaction of the spin magnetic moment and rotational induced molecular magnetic moment. Explicitly these terms are written classically as:

$$\begin{aligned}
 H = & \frac{P_N^2}{2I} + \frac{e^2}{m^2c^2} \sum_{i,k} - \frac{3(P_{Si} \cdot r_{ik})(P_{Sk} \cdot r_{ik}) + P_{Si} \cdot P_{Sk} |r_{ik}|^2}{|r_{ik}|^5} \\
 & + \frac{e}{2mc^2} \sum_i (F_i x v_i) \cdot P_{Si} + \frac{e}{mc} \sum_i B_i \cdot P_{Si} \quad \text{(IX.1)}
 \end{aligned}$$

where

$$\epsilon_i = \sum_k \frac{q_i r_{ik}}{|r_{ik}|^3}$$

$$\mathbf{B}_i = - \sum_k \frac{r_{ik} \times v_k q_k}{c|r_{ik}|^3}$$

and  $\mathbf{P}_{Si}$  is the spin angular momentum of the  $i$ th electron.

The third term in equation (IX.1) describes the Thomas form for the interaction of an electron spin magnetic moment with the magnetic field of its own rotation induced angular momentum, while the fourth term includes the interaction of the spin magnetic moment with the magnetic fields resulting from the angular momentum of the positively charged nuclei and the rotation induced angular momentum of the other electrons. Since the rotation induced electronic angular momentum is, from Chapter VI, proportional to  $\mathbf{P}_N$ , these two terms may be shown to be equivalent to

$$\frac{2\pi\mu\mathbf{P}_n \cdot \mathbf{P}_S}{\hbar} \quad . \quad . \quad . \quad (IX.2)$$

The second term in expression (IX.1) may be expanded in terms of the components of the vectors on the molecule fixed  $g$ -axes. Cross product terms such as  $(r_{ik})_g(r_{ik})_{g'}$  have no matrix elements diagonal in the electronic angular momentum quantum numbers from symmetry of the oxygen molecule. We are only concerned with the terms:

$$\mathbf{H}_{SS} = \frac{e^2}{m^2 c^2} \sum_{i, k, g} \frac{(\mathbf{P}_S)_{ig}(\mathbf{P}_S)_{kg} [-2(g_{ik})^2 + (g'_{ik})^2 + (g''_{ik})^2]}{|r_{ik}|^5} \quad . \quad . \quad . \quad (IX.3)$$

From symmetry also  $x_{ik}^2 = y_{ik}^2$ , if  $z_{ik}$  is the component of  $r_{ik}$  on the internuclear axis. This simplifies equation (IX.3) to:

$$\mathbf{H}_{SS} = \frac{e^2}{m^2 c^2} \sum_{i, k} \frac{(z_{ik}^2 - x_{ik}^2)}{|r_{ik}|^5} \quad . \quad . \quad . \quad (IX.4)$$

$$[(\mathbf{P}_S)_{ix}(\mathbf{P}_S)_{kx} + (\mathbf{P}_S)_{iy}(\mathbf{P}_S)_{ky} - 2(\mathbf{P}_S)_{iz}(\mathbf{P}_S)_{kz}] \quad . \quad (IX.4)$$

Oxygen has only two unbalanced electrons, so  $i, k = 1, 2$ . The components of the total spin  $\mathbf{P}_S$  are  $(\mathbf{P}_S)_x = (\mathbf{P}_S)_{1,x} + (\mathbf{P}_S)_{2,x}$ . Equation (IX.4) may then be simplified by writing it as:

$$\mathbf{H}_{SS} = \frac{e^2}{m^2 c^2} \left\langle \frac{z_{12}^2 - x_{12}^2}{|r_{12}|^5} \right\rangle \{ \mathbf{P}_S^2 - 3P_{S_z}^2 - \sum_{i=1,2} [(P_S)_{i_x}^2 - 3(P_S)_{i_z}^2] \} \quad (\text{IX.5})$$

The squares of the individual spin operators and the total spin angular momentum are constants for the ground electronic state, so only the dependence of  $\mathbf{H}_{SS}$  on  $P_{S_z}^2$  is of interest. For notational simplicity, we may write

$$\mathbf{H}_{SS} = 4\pi\lambda P_{S_z}^2 / \hbar \quad (\text{IX.6})$$

The quantum representation of the Hamiltonian of equation (IX.1) may conveniently be given in a representation known as Hund's type "a". This is a representation in which the square of the total spin angular momentum  $\mathbf{P}_S$  is diagonal and equal to  $S(S+1)\hbar^2$  and its  $z$  axis projection is diagonal and equal to  $\Sigma\hbar$ . The square of the total angular momentum,  $\mathbf{P}$ , may also be taken as diagonal and equal to  $F(F+1)\hbar^2$ , its  $z$  axis projection being also  $\Sigma\hbar$  (since  $\mathbf{P}_N$  has no  $z$  axis component) and its  $Z$  axis component  $M\hbar$ . In this representation the terms  $\mathbf{P}_N \cdot \mathbf{P}_S$  of equation (IX.2) and  $\mathbf{P}_N^2$  of equation (IX.1) are given as:

$$\begin{aligned} \mathbf{P}_N \cdot \mathbf{P}_S &= \mathbf{P} \cdot \mathbf{P}_S - P_S^2 \\ \mathbf{P}_N^2 &= \mathbf{P}^2 + P_S^2 - 2\mathbf{P} \cdot \mathbf{P}_S \end{aligned} \quad (\text{IX.7})$$

With the aid of equations (IX.2), (IX.6), and (IX.7), equation (IX.1) may be given as:

$$\mathbf{H} = 2\pi b \mathbf{P}^2 / \hbar + 2\pi(\mu - 2b) \mathbf{P} \cdot \mathbf{P}_S / \hbar + 4\pi\lambda P_{S_z}^2 / \hbar \quad (\text{IX.8})$$

Terms in  $P_S^2$  have been suppressed, since they are constant for the ground electronic state. The matrix elements of  $\mathbf{P} \cdot \mathbf{P}_S$  must now be considered. This term is just  $P_x P_{S_x} + P_y P_{S_y} + P_z P_{S_z}$ , the last term being diagonal and equal to  $\Sigma^2 \hbar^2$  from our choice of representation. The commutation

relations for  $P_S$  may be solved to yield the matrix elements of  $P_{S_x}$  and  $P_{S_y}$  in the ground electronic state. These relations are:

$$P_{S_y}P_{S_y'} - P_{S_y'}P_{S_y} = i\hbar P_{S_x} \quad . \quad . \quad (IX.9)$$

The sign of  $i$  is plus since the components are measured with respect to the assumed fixed molecular co-ordinates. The solution to equation (IX.9) with the constraint that  $P_S^2 = S(S+1)\hbar^2$  is identical in form to that for  $P_X$  and  $P_Y$

$$\begin{aligned} (S, \Sigma | P_{S_y} | S, \Sigma \pm 1) &= \pm i(S, \Sigma | P_{S_x} | S, \Sigma \pm 1) \\ &= \frac{\hbar}{2} \sqrt{S(S+1) - \Sigma(\Sigma \pm 1)} \quad . \quad (IX.10) \end{aligned}$$

From the known matrix elements of  $P_x$  and  $P_y$  we have,

$$\begin{aligned} (F, F_z = \Sigma, M, S, S_z = \Sigma | P_x P_{S_x} + P_y P_{S_y} | \\ F, F_z = \Sigma \pm 1, M, S, S_z = \Sigma \pm 1) \\ = \frac{\hbar^2}{2} \sqrt{[F(F+1) - \Sigma(\Sigma \pm 1)][S(S+1) - \Sigma(\Sigma \pm 1)]} \quad . \quad . \quad (IX.11) \end{aligned}$$

The matrix element notation of equation (IX.11) may be simplified by noting that  $F_z = S_z$ , hence only one  $\Sigma$  need be used to designate the matrix elements of the Hamiltonian. Equation (IX.8) is now written as:

$$\begin{aligned} (F, M, S, \Sigma | H | F, M, S, \Sigma) \\ = bF(F+1)h - (2b - \mu - 2\lambda)\Sigma^2 h \\ (F, M, S, \Sigma | H | F, M, S, \Sigma \pm 1) = -\frac{h}{2}(2b - \mu) \\ \sqrt{[F(F+1) - \Sigma(\Sigma \pm 1)][S(S+1) - \Sigma(\Sigma \pm 1)]} \quad . \quad . \quad (IX.12) \end{aligned}$$

For the ground state of oxygen  $S = 1$ ,  $\Sigma = 0, \pm 1$ , so the matrix of the Hamiltonian of a given  $F$  state is

$$\begin{array}{c}
 \Sigma = -1 \quad \quad \quad \Sigma = 0 \quad \quad \quad \Sigma = 1 \\
 \\
 \Sigma = -1 \quad \left[ \begin{array}{ccc}
 b[F(F+1) - 2] & -\frac{1}{2}(2b - \mu) & 0 \\
 + 2\lambda + \mu & \sqrt{2F(F+1)} & . \\
 \\
 \Sigma = 0 & \frac{1}{2}(2b - \mu) & bF(F+1) & \frac{1}{2}(2b + \mu) & . \\
 \sqrt{2F(F+1)} & . & \sqrt{2F(F+1)} & \\
 \\
 \Sigma = 1 & 0 & \frac{1}{2}(2b + \mu) & b[F(F+1) - 2] \\
 & & \sqrt{2F(F+1)} & + 2\lambda + \mu
 \end{array} \right] h
 \end{array}
 \quad . \quad . \quad (IX.13)$$

The symmetrizing transformation X factors each F factor of H into the form

$$(F|H|F) = h \left[ \begin{array}{cc}
 b[F(F+1) - 2] & \\
 + 2\lambda + \mu & \\
 \\
 & bF(F+1) & \\
 & & \sqrt{F(F+1)} \\
 \\
 & (2b - \mu) & b[F(F+1) - 2] \\
 & \sqrt{F(F+1)} & + 2\lambda + \mu
 \end{array} \right]
 \quad . \quad . \quad (IX.14)$$

The most abundant isotopic form of the oxygen molecule is the homonuclear molecule with  $O^{16}$  nuclei which have zero spin. The Pauli exclusion principle thus requires that when F is odd then only the antisymmetric combination of  $\Sigma$  states be used, i.e., the first row and column of equation (IX.14).

$$F_{\text{odd}} : W_F = h\{b[F(F+1) - 2] + 2\lambda + \mu\} \quad . \quad (IX.15)$$

When F is even the symmetric  $\Sigma = 0$  state and the symmetric combination of  $\Sigma = +1$  states is allowed. This includes just the last two rows and columns of equation (IX.14), so the

energy given by the solution of the quadratic secular determinant is:

$$E_{\text{even}} : W_F = h \{ bF(F+1) + b + \lambda + \mu/2 \pm \sqrt{\lambda^2 + \lambda(2b - \mu) + (b - \mu/2)^2(2F+1)^2} \} \quad (\text{IX.16})$$

The evolution of the spin-rotation triplet depicted by equations (IX.15) and (IX.16) may be shown as in Fig. 5.

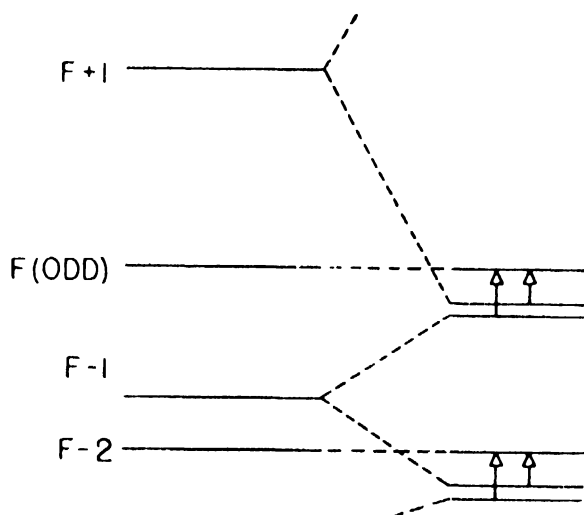

Fig. 5. Oxygen spin triplet

The selection rule on  $F$  is  $\Delta F = \pm 1, 0$  and so the transition frequencies may be indicated, with  $b - \mu/2 = b_0$ , as:

$$\begin{aligned} \nu_{F+1 \rightarrow F} &= (2F+3)b_0 + \lambda - \mu(F+1) \\ &\quad + \sqrt{(2F+3)^2 b_0^2 + \lambda^2 - 2\lambda b_0} \\ \nu_{F-1 \rightarrow F} &= (2F-1)b_0 + \lambda + \mu F \\ &\quad - \sqrt{(2F-1)^2 b_0^2 + \lambda^2 - 2\lambda b_0} \quad (\text{IX.17}) \end{aligned}$$

These frequencies are approximately 60,000 Mc/s, the approximate empirical values for the parameters being,  $b_0 = 43,101$  Mc/s,  $\lambda = 59,475$  Mc/s, and  $\mu = -255$  Mc/s.

### B. Ammonia ( $\text{NH}_3$ )

In the ammonia molecule the nitrogen nucleus sits at the apex of a pyramid over the plane of the three hydrogen

nuclei. The potential holding the nitrogen nucleus out of the plane of the hydrogen nuclei is large but finite. For this reason, any vibrational state of the ammonia molecule involving a motion of the nitrogen nucleus perpendicular to the plane of the hydrogens will have a potential curve in terms of the normal co-ordinate  $q$  as shown in Fig. 6 (b). Fig. 6 (a)

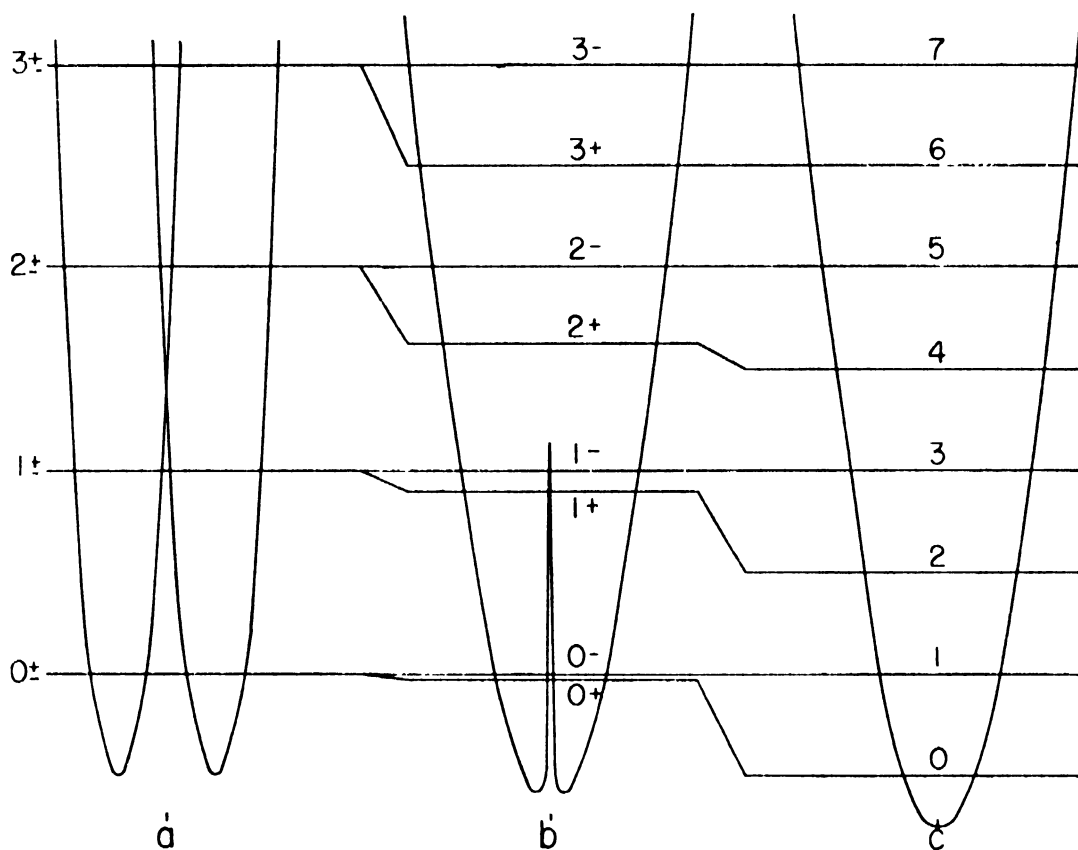

Fig. 6. Vibration potential energy forms

illustrates the usual simple potential that would exist if the nitrogen were repelled from the hydrogen plane by an infinite potential; the possibility of the nitrogen being on either side of the plane being recognized. Fig. 6 (c) indicates the potential for the case of no barrier at the plane of the hydrogen nuclei, i.e., for the case of the equivalent planar molecule.

The characteristic energy levels for cases (a) and (c), when the two halves of (c) do not interact are  $W_c = h\nu_c(v + \frac{1}{2})$  and roughly  $W_a = 2h\nu_c(v + \frac{1}{2})$ . The levels for  $W_a$  are doubly degenerate since two potentials are involved. The levels for the hindering potential case (b), are qualitatively determined

by noting that for low vibrational energy case (*b*) is approximated by case (*a*), while for high vibrational energies the hindering potential is of little relative importance and case (*b*) is approximated by case (*c*). Intermediate levels are interpolated as in Fig. 6.

Most molecules having an inversion are of the form of case (*a*). The possibility of inversion brings about a doubling of vibrational states, while the improbability of the inversion makes them degenerate. Proper state functions for these degenerate levels are, as usual, the symmetric and anti-symmetric combinations of the individual degenerate states of oscillation on either side of the infinite barrier potential. The symmetry symbol ( $\pm$ ) used for cases (*a*) and (*b*) give, in fact, the oddness or evenness of the equivalent vibrational state quantum number in case (*c*).

Ammonia is then truly a perturbed form of case (*a*) though for the sake of quantitative simplicity it will be considered as a perturbation of case (*c*). In a representation in which the harmonic terms of case (*c*) are diagonal the matrix elements of the normalized co-ordinate and momentum are:

$$(v|q|v \pm 1) = \left( \frac{2v + 1 \pm 1}{2} \right)^{\frac{1}{2}}$$

$$(v|p|v \pm 1) = \pm i\hbar \left( \frac{2v + 1 \pm 1}{2} \right)^{\frac{1}{2}}$$

$$W_v = hv_e(v + \frac{1}{2})$$

The hindering potential may be taken to be of the form:

$$H_h = V_0 e^{-\frac{q^2}{a^2}}$$

The exponential may be expanded in an absolutely converging series in  $q^{2n}$ , and so the matrix elements of  $H_h$  are immediately determined in terms of the matrix elements of the even powers of  $q$ . The matrix elements of  $q^2$  are of the type

$(v|v)$  and  $(v|v \pm 2)$  and so the matrix elements of  $\mathbf{H}_h$  are of the form  $(v|v \pm 2n)$ , where  $n$  is a positive integer and  $v - 2n \geq 0$ .

$$(v|\mathbf{H}_h|v \pm 2n) = V_0 \sum_l (-1)^l \frac{(v|q^{2l}|v \pm 2n)}{(l)!d^{2l}}$$

The problem is now formally (if not practically) solved. The matrix elements of the vibrational plus barrier Hamiltonian are known. The new, perturbed, energy levels  $W_{vi}$  are determined by forming the infinite secular determinant from this matrix, and setting it equal to zero.

$$|(v|\mathbf{H}_v + \mathbf{H}_h|v') - \delta_{vv'}W_{vi}| = 0$$

This is a tedious procedure to carry out exactly, but some insight of the problem is gained by considering approximations. This sum may be put into closed form as, for example:

$$(0|\mathbf{H}_h|0) = V_0 d / (1 + d^2)^{\frac{1}{2}}$$

$$(1|\mathbf{H}_h|1) = V_0 d^3 / (1 + d^2)^{\frac{3}{2}}$$

$$(2|\mathbf{H}_h|2) = [V_0 d / 2(1 + d^2)] [1 + 2d^4]$$

Two simplifications of the problem are now evident. First, the barrier perturbation, being an even function of  $q$ , has matrix elements only between even values of  $v$  or only between odd values of  $v$ . Since the harmonic energy is already diagonal, the matrix formed by the addition of the barrier potential is immediately factorable into two sub-matrices of even and odd  $v$ . Second, the general form of the matrix elements of  $\mathbf{H}_h$  for even  $v$  have a leading term in  $V_0 d$ , while those for odd  $v$  have a leading term in  $V_0 d^3$ . Since  $d < 1$ , i.e., the barrier width is less than the characteristic ground state normal co-ordinate  $q$ , the perturbation of the odd  $v$  states may be ignored for a first approximation.

Many of the matrix elements of  $\mathbf{H}_h$  may be determined most easily by recursion relations derived by demanding that the Hamiltonian commute with powers of  $q$ . For example,

consideration of the  $(v + 1|v)$  term of the general relation  $q\mathbf{H}_h - \mathbf{H}_hq = 0$  leads to the equation:

$$\begin{aligned} \sqrt{v+1}[(v|\mathbf{H}_h|v) - (v+1|\mathbf{H}_h|v+1)] \\ = \sqrt{v}(v-1|\mathbf{H}_h|v+1) - \sqrt{v+2}(v+2|\mathbf{H}_h|v) \end{aligned}$$

and with  $v = 0$  and 1 the following relations are obtained:

$$\begin{aligned} (0|\mathbf{H}_h|0) - (1|\mathbf{H}_h|1) &= -\sqrt{2}(2|\mathbf{H}_h|0) \\ \sqrt{2}[(1|\mathbf{H}_h|1) - (2|\mathbf{H}_h|2)] &= (0|\mathbf{H}_h|2) - \sqrt{2}(3|\mathbf{H}_h|1) \end{aligned}$$

If terms in  $d^3$  are to be neglected these equations quickly yield the approximate matrix elements for even  $v$  by setting the odd  $v$  matrix elements equal to zero. A few more examples will be given. Since

$$(0|q^2\mathbf{H}_h - \mathbf{H}_hq^2|v) = 0$$

then:

$$\begin{aligned} \sqrt{2}(2|\mathbf{H}_h|v) = \sqrt{(v+2)(v+1)}(0|\mathbf{H}_h|v+2) \\ + \sqrt{v(v-1)}(0|\mathbf{H}_h|v-2) + 2v(0|\mathbf{H}_h|v) \end{aligned}$$

Since

$$(0|q\mathbf{H}_h - \mathbf{H}_hq|v+1) = 0$$

then:

$$(1|\mathbf{H}_h|v+1) = \sqrt{v+1}(0|\mathbf{H}_h|v) + \sqrt{v+2}(0|\mathbf{H}_h|v+2)$$

When  $v$  is even then

$$0 \cong \sqrt{v+1}(0|\mathbf{H}_h|v) + \sqrt{v+2}(0|\mathbf{H}_h|v+2)$$

For the case of ammonia only the symmetrical stretching vibrational state is appreciably perturbed by the inversion barrier. If the states of odd  $v$  for this vibrational state are considered unperturbed, then only the  $v = 0, 2,$  and 4 states are appreciably perturbed from their simple harmonic energies. The experimentally observed energy shifts are:

$$\begin{aligned} \Delta(v=0) &\cong h\nu_c \\ \Delta(v=2) &\cong 0.95h\nu_c \\ \Delta(v=4) &\cong 0.35h\nu_c \end{aligned}$$

If the approximate secular determinant involving only  $v = 0, 2, 4, 6$  is diagonalized by continued fraction form the slow convergence of harmonic oscillator perturbation calculations is evident. Some simplification results by assuming trial solutions of the form  $W_v = h\nu_c(v + \frac{1}{2}) + \Delta(v)$  with the observed value of  $\Delta(v)$  being used. This procedure should generate  $\Delta(v)$  for an appropriate value of  $V_0d$ . A rough calculation of this type indicates  $V_0d \approx 2h\nu_c$  and since  $V_0$  must be of the order of  $4h\nu_c$  (since its effect nearly vanishes for vibrational states of energy higher than this) then  $d$  must be of the order of  $\frac{1}{2}$ . Certainly in this event a more careful calculation must be made. This problem is not of sufficient general interest however to justify further discussion.

Suffice it to say that the ground state splitting ( $0 \rightarrow 0$ ) is characteristic of a microwave frequency. Actually not a single absorption occurs, for vibration-rotation interaction makes the transition frequency dependent upon the rotational state quantum numbers  $J$  and  $K$ . An experimentally derived expression for this inversion transition frequency is given by

$$\begin{aligned} \nu = & 23,785.8 - 151.450J(J + 1) + 211.342K^2 \\ & + 0.503027(J + 1)^2 - 1.38538J(J + 1)K^2 + 0.040155K^4 \\ & - 0.001259997J^3(J + 1)^3 + 0.005182367J^2(J + 1)^2K^2 \\ & - 0.007088534J(J + 1)K^4 + 0.003210437K^6 \text{ Mc/s} \end{aligned}$$

$K \neq 3$  (Inexact),  $K \neq 0$  (Unallowed)

These absorption frequencies are accurately known and since the absorption is relatively intense, they provide frequency standards for a portion of the microwave region.

It is well to make one final point regarding transition probabilities. The dipole moment components  $\mu_q$ , referred to in Chapter VIII, are the average dipole moment components for a given electronic and vibrational state. Ammonia, for example, has its charge co-ordinates directly proportional to the inversion normal co-ordinate  $q$ . The vibration-inversion matrix elements of the dipole moment are then proportional to the matrix elements of  $q$ . The dipole moment thus has

matrix elements different from zero only when an inversion transition is involved. This is physically reasonable, for the mean value of a dipole moment of an inverting molecule must certainly be zero. In short, not only must a rotational transition be made to have a finite absorption intensity, but also an inversion transition must be simultaneously induced. For most molecules having an inversion state, other than ammonia, the inversion rotation transition is between degenerate inversion levels and the inversion in no way affects the rotational spectrum. Ammonia, however, has a microwave vibration-rotation spectrum in which the rotational transitions are between degenerate  $K$  rotational states and non-degenerate inversion states. The dipole moment component  $\mu_z$  will not be its value diagonal in electronic and vibrational quantum numbers, but its value diagonal in electronic quantum numbers and off-diagonal in the inversion quantum number, or rather the inversion index ( $\pm$ ), i.e.,  $\mu_g = (+ |\mu_g| -)$ .

## CHAPTER X

### EXPERIMENTAL CONSIDERATIONS

THE understanding of the apparatus for microwave spectroscopy demands much practical and theoretical knowledge of electric circuits, both lumped and distributed. This section will assume a fair amount of familiarity with these things and will attempt to justify only the special considerations which must be observed. There are so many good reference texts on the behaviour of microwave and lumped constant circuits that omission of general material will be of little inconvenience to those whose interests or adaptabilities have attracted them to this field in the first place.

In the section that follows brief consideration will be given to essentially a single type of microwave spectroscope. Though the view may seem limited, the waveguide-Stark modulated type to be considered is certainly the workhorse of the field and special types of systems are very readily studied by comparison with a single, well-understood apparatus.

It must be borne in mind that even a single general apparatus is susceptible to many modifications of detail. The actual form of the details will be dictated little by the general problem but mainly by the background and inclinations of the designer and by the need to obtain facility and efficiency of the apparatus in such a fashion as to utilize available components. It is therefore of little meaning to consider details in general and for that reason particular details in the following should be considered only as a locally accepted engineering approximation to the desired end.

The spectroscope which will be used to study the rotational energy levels of a molecule may be conveniently idealized as a three component system. Monochromatic radiation from a suitable source is caused to traverse a cell containing the gas to be studied and then is absorbed by a detector.

With a given power  $P_i$  incident on the cell we calculate the signal power induced by switching from a condition of absorption in the cell to no absorption in the cell. This switching may be accomplished (1) by changing the frequency of the radiation from the resonant frequency to a frequency far from resonance, (2) by pumping the gas from the cell, or (3) by shifting the resonant frequency by an applied electric or magnetic field. In principle all absorption detection schemes may be thought of in terms of this switching model.

Incident power on the detector is given as:

$$P_0 = P_i e^{-(\gamma_c + \gamma)l} \quad . \quad . \quad . \quad (X.1)$$

where  $\gamma_c$  = cell absorption coefficient,

$\gamma$  = gas absorption coefficient,

$l$  = equivalent free space length of cell.

Since  $\gamma$  may be thought of as time dependent with a fundamental frequency  $f$ , the radiation is considered amplitude modulated with a voltage modulation index  $1 - e^{-\frac{\gamma l}{2}} \cong \frac{\gamma l}{2}$ , since limiting values of  $\gamma l$  are very much less than 1. If  $\gamma$  is square wave modulated the amplitude of the fundamental component is  $\frac{\pi}{2} \cdot \frac{\gamma l}{2}$  with respect to the carrier and hence the relative voltage amplitude of each fundamental side band is  $\frac{\gamma l}{2\pi}$ . The total mean signal side band power is thus:

$$P_s = P_i e^{-\gamma l} \cdot \frac{\gamma^2 l^2}{4\pi^2} \quad . \quad . \quad . \quad (X.2)$$

The noise in competition with this signal arises from the radiation source, the detector and the first stages of the amplifier. The noise power contribution of these sources per cycle per second may be written in terms of a coefficient and the available thermal noise power/c/s,  $kT$ .

The signal to noise power ratio in the amplifier is thus given as:

$$\frac{GP_s}{P_n} = \frac{GP_i e^{-\gamma d} \cdot \frac{\gamma^2 I^2}{4\pi^2}}{(Gs + d + a - 1)kTB} \quad (X.3)$$

where  $G$  = detector conversion loss factor,

$s$  = source noise proportionality factor,

$d$  = detector noise proportionality factor,

$a$  = amplifier noise proportionality factor,

$B$  = amplifier bandwidth.

Optimum system design then is a matter of selecting components to maximize this signal to noise ratio.

Unfortunately little is known about the factor  $s$ . As sources of radiation one has klystrons or magnetrons from which to choose. For ease of operation klystrons are generally chosen as a source. The value of  $s$  for klystrons or magnetrons is in doubt and difficult to measure. In any case engineering experience shows that it is indeed difficult to make oscillators with a noise power/c/s much less than  $10^{-15}$  of the carrier level. That magnetrons can be made consistently as good as this is doubtful. Klystrons may possibly be as good as this at frequencies near the carrier. Published measurements with klystrons indicate that the noise power/c/s at 10 Mc/s and 30 Mc/s away from the carrier is about  $10^{-16}$  below the carrier. This noise may be thought to be due to the simple diode noise output of the klystron having a beam current  $I$  and an effective cavity shunt resistance of  $R_s$ . This noise power/c/s is then just  $2eIR_s$  and will vary only slowly with frequency deviation from the carrier since  $R_s$  is a slowly varying function. Thus the klystron noise power/c/s measured several megacycles per second from the carrier should be within an order of magnitude of the noise power/c/s, within a few hundred cycles per second from the carrier. This has been verified in the writer's laboratory using a barretter detector at 600 c/s. One is tempted then, to write the factor  $s$ ,

which should be not too pessimistic for any good source of radiation, as:

$$s = P_i e^{-\gamma d} / 10^{16} kT \quad . \quad . \quad . \quad (X.4)$$

The available detectors are either the germanium or silicon crystal diodes or thermal detectors. Crystal diodes have a randomly variable component of resistance which depends on the frequency as  $1/f$ . For this reason the factor  $d$  depends upon the incident power and monitoring frequency  $f$  as:

$$d = R \frac{P_i^{1/2} e^{-2\gamma d}}{f} + 1 \quad . \quad . \quad . \quad (X.5)$$

$R$  is a constant of a particular crystal and microwave region. Thermal detectors appear essentially as a pure resistance with  $d$  probably no greater than 2. However, the conversion loss  $G$  for these two detectors is greatly different in magnitude, though for both both conversion gain is proportional to the the incident power and may be given as:

$$G = SP_i e^{-\gamma d} \quad . \quad . \quad . \quad (X.6)$$

where  $S$  is also a constant of the individual detector.

Present crystal detectors have an  $S$  which is roughly  $10^3$  times that of available barretters or thermal detectors, e.g., for a 1N26 crystal at low levels (below  $10^{-3}$  W)  $S$  is about  $10^4$  W $^{-1}$ , while for a barretter with a typical sensitivity of 40 V/W at a 200 ohm level  $S$  is given as  $40^2/200 = 8$  W $^{-1}$ .

The amplifier noise factor will depend on the monitoring frequency  $f$ , but for less than  $10^6$  c/s it should be about 1, since at these frequencies transit time places negligible restriction on achievable amplifier noise figure. With reasonable design care it will certainly be no worse than 2.

The criterion for detection of the effect of an absorption may be taken as being a signal to noise ratio of 1. With  $a = 2$ , equation (X.3) may then be solved for  $\gamma$  as:

For crystal detector:

$$\gamma_{\min} = \frac{2\pi}{l} \sqrt{kTB} \left( \frac{10^{-16}}{kT} + \frac{R}{Sf} + 2S^{-1}P_i^{-1/2}e^{2\gamma d} \right) \quad . \quad (X.6a)$$

For thermal detector:

$$\gamma_{\min} = \frac{2\pi}{l} \sqrt{kTB \left( \frac{10^{-16}}{kT} + 3S^{-1}P_i^{-2}e^{2\gamma_c l} \right)} \quad . \quad . \quad (X.6b)$$

It may be seen from equation (X.6a) that the optimum length of cell for a crystal detector is that which reduces the generator power at the detector so that the additional noise power due to the source and detector equals the amplifier input noise. For typical values  $R = 10^{16} \text{ W}^{-2}\text{sec}^{-1}$ ,  $S = 10^4 \text{ W}^{-1}$ ,  $f = 6 \times 10^3 \text{ c/s}$ ,  $P_i = 10^{-3} \text{ W}$ ,  $l_{\text{opt}}$  is about  $6/\gamma_c$ . Though this length varies logarithmically with incident power  $P_i$ , a rough value for the minimum detectable signal may be given as:

$$\begin{aligned} \gamma_{\min} &\cong \frac{\gamma_c \pi}{3} \sqrt{2kTB \left( \frac{R}{Sf} + \frac{10^{-16}}{kT} \right)} \\ &\cong 9 \times 10^{-11} \gamma_c \sqrt{\left( \frac{R}{Sf} + \frac{10^{-16}}{kT} \right) B} \quad . \quad (X.7) \end{aligned}$$

For a thermal detector, equation (X.6b) shows that the optimum length is one which reduces the source noise power to a level comparable with the amplifier input noise. Again roughly,  $\gamma_c l$  must be about 1 so that the minimum detectable absorption coefficient is

$$\gamma_{\min} \cong 2\pi\gamma_c \sqrt{2 \times 10^{-16} B} \quad . \quad . \quad (X.8)$$

The form for equation (X.8) is so chosen to indicate that the limiting sensitivity of a thermal detector system depends upon the noise contribution of the generator, typified by the  $10^{-16}/\text{c/s}$  factor which we have assumed. In any case equations (X.7) and (X.8) are roughly equivalent. These equations also show the well-known fact that any sensitivity is available as long as one is willing to restrict  $B$  to a small enough value. This means that the response time of the system must become very long and the data-taking time accordingly lengthened.

B may be taken reasonably as small as  $10^{-2}$  c/s in which case a typical limiting value for  $\gamma$  is about  $10^{-8}\gamma_c$  or about  $10^{-11}$  cm $^{-1}$  for a waveguide cell for 1-cm wavelength radiation, and at least 60 m long! A realistic cell length would be less than optimum and the  $\gamma_{\min}$  would be somewhat larger.

## CHAPTER XI

### SOURCES OF RADIATION

As we have remarked previously, klystrons of the reflex type are generally used as sources for microwave radiation. The source noise is apparently tolerable and this type of tube is readily tuned in frequency by variation of the reflector anode potential as a fine tuning control and by mechanical deformation of the resonant cavity as a coarse tuning control. Tubes are available to cover most of the microwave region. They have reasonable input power requirement, the d.c. voltages running from 300 V to 3000 V with d.c. current drain the order of 10 to 50 mA. Power output is a convenient amount, ranging from a few to hundreds of milliwatts.

In regions where fundamental oscillators are not available, frequency multiplication by non-linear elements such as silicon crystals has been used. Such a procedure lowers the available power and undoubtedly increases the effective source noise power. This condition is tolerated since the associated detectors are poor and much less than optimum operating sensitivity is needed to do effective work. It will be noted that the system parameters appear under a square root radical so their variation has a much less drastic effect on the minimum detectable absorption than might be supposed. Furthermore, these frequency multiplying techniques need only be resorted to at frequencies in excess of 35,000 Mc/s and here the frequency dependence of the absorption coefficient allows larger values of  $\gamma$  to be expected for equivalent interaction of a molecule with the radiation field.

The use of microwave frequency multiplication techniques is not to be advised for general use for it requires the development of microwave R.F. circuits to accomplish the multiplication. These are not generally available commercially.

The klystrons themselves should be operated from very

good power supplies, to obtain as clean and stable a c.w. carrier as possible. The frequency may then be swept in a controlled fashion by applying a low repetition frequency saw-tooth potential to the reflector anode or the course tuning adjustment may be driven from a gear train and motor.

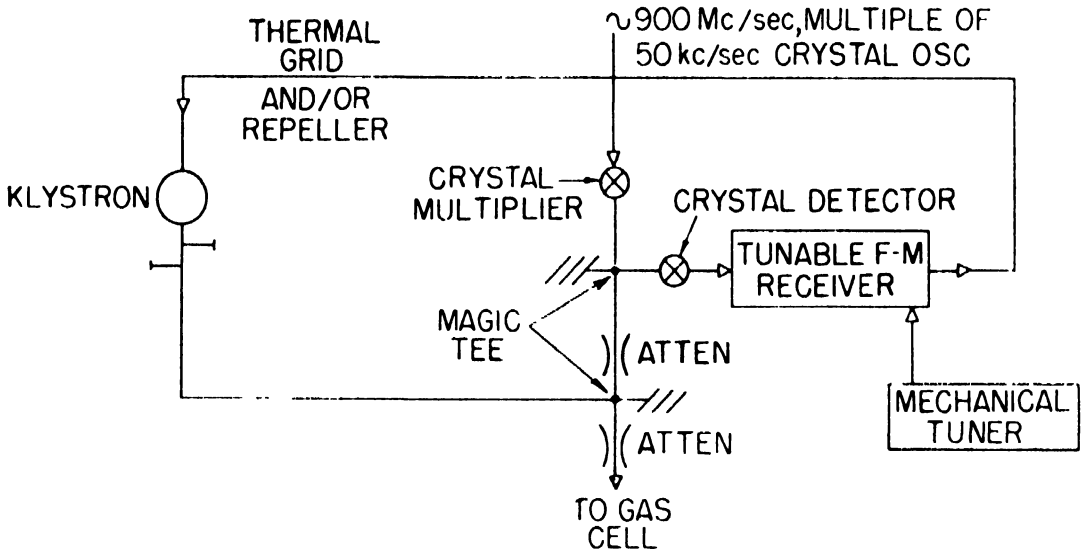

Fig. 7. Frequency stabilizer block diagram

Alternatively, and more elegantly, the klystron may be locked with a variable difference frequency from a frequency stable oscillator, and the difference frequency varied slowly with time. If a frequency standard is available harmonics of it may be used to improve the klystron stability in this way. Fig. 7 shows a block diagram of such an arrangement. Alternatively, the stable frequency may be derived from a second fixed-frequency, cavity-stabilized, klystron.

## CHAPTER XII

### SAMPLE CELL

A DISCUSSION of sample cells must be prefaced by a few remarks on resolution. In spectroscopic measurements high accuracy is dependent upon the minimum line breadth that may be obtained compatibly with signal strength. We have seen that the line broadening due to pressure may be reduced with no loss in intensity, as long as the mean free path is proportional to pressure. Certainly this will not be the case when the smallest cell dimension becomes comparable with the mean free path. Lowering the pressure further in an attempt to lengthen the mean free path will thus be of no avail and the line will remain nearly constant in shape and diminish in intensity. If the cell dimensions are further increased to accommodate longer mean free paths, other causes of line broadening may become of importance and limit further attempts to reduce line breadth by lowering the vapour pressure. Doppler broadening, caused by the motion of the molecules relative to the electromagnetic field equi-phase surfaces, will also set a lower limit on the reduction of line breadth. Natural line breadth in the microwave region is usually negligible.

These various sources of line broadening may be listed in engineering formulae for quick calculation as:

$$\Delta\nu_R \cong 10\mu \sqrt{\frac{P}{A}} \text{ Mc/s} \quad \text{due to radiation field}$$

$$\Delta\nu_D \cong 6\nu \left( \frac{T}{300M} \right)^{\frac{1}{2}} 10^{-6} \text{ Mc/s} \quad \text{due to Doppler}$$

$$\Delta\nu_W \cong \frac{1}{85a} \left( \frac{T}{M} \right)^{\frac{1}{2}} \text{ Mc/s} \quad \text{due to walls of cell}$$

where  $\mu$  is dipole moment in debye ( $10^{-18}$  esu-cm), P is radiation power in watts, A is guide cross-section in square centimetres,  $\nu$  is absorption frequency in megacycles per second, M is molecular weight,  $a$  is smallest guide dimension in centimetres.

In short, a cell should be chosen so that these limiting line breadths are the same order of magnitude. This means that a wave guide cell of generous dimensions and cross-sectional area should be used.

In order to differentiate between variation of power with frequency due to electrical properties of source, cell or detector a method of modulating the absorption must be used. Since nearly all molecules of interest have electric dipole moments the Stark modulation scheme is generally used. This requires an electrode within the cell, preferably of a configuration such as to produce a nearly uniform electric field so that a unique value may be assigned to the field strength. This Stark electrode is most suitably placed symmetrically within a rectangular guide so as to interfere as little as possible with the radiation field, as in Fig. 8. This arrangement yields a high static field uniformity in the central portion of the guide where the radiation electric field is the greatest, i.e., where the majority of the actual transitions occur. The electrostatic stresses on the guide are also symmetrical so that as the static electric field is varied in amplitude a minimum amount of energy is coupled into the mechanical vibrational modes of the cell. This is a very important consideration, for such mechanical modulation may also modulate the transmitted power in a fashion indistinguishable from the modulation due to an absorbing molecule. This mechanical modulation gives rise, in the detector, to what is known as guide noise, i.e., any signal independent of the gas in the cell, which is coherent with the Stark modulation potential. Even the symmetrical electrode may cause guide noise, for the electrostatic stresses will tend to set vibrations as shown in cross section in Fig. 9. The division of power between the top and bottom sections of the guide is in this way time dependent. The recombination of these two fields on the far end of the cell will occur unperturbed

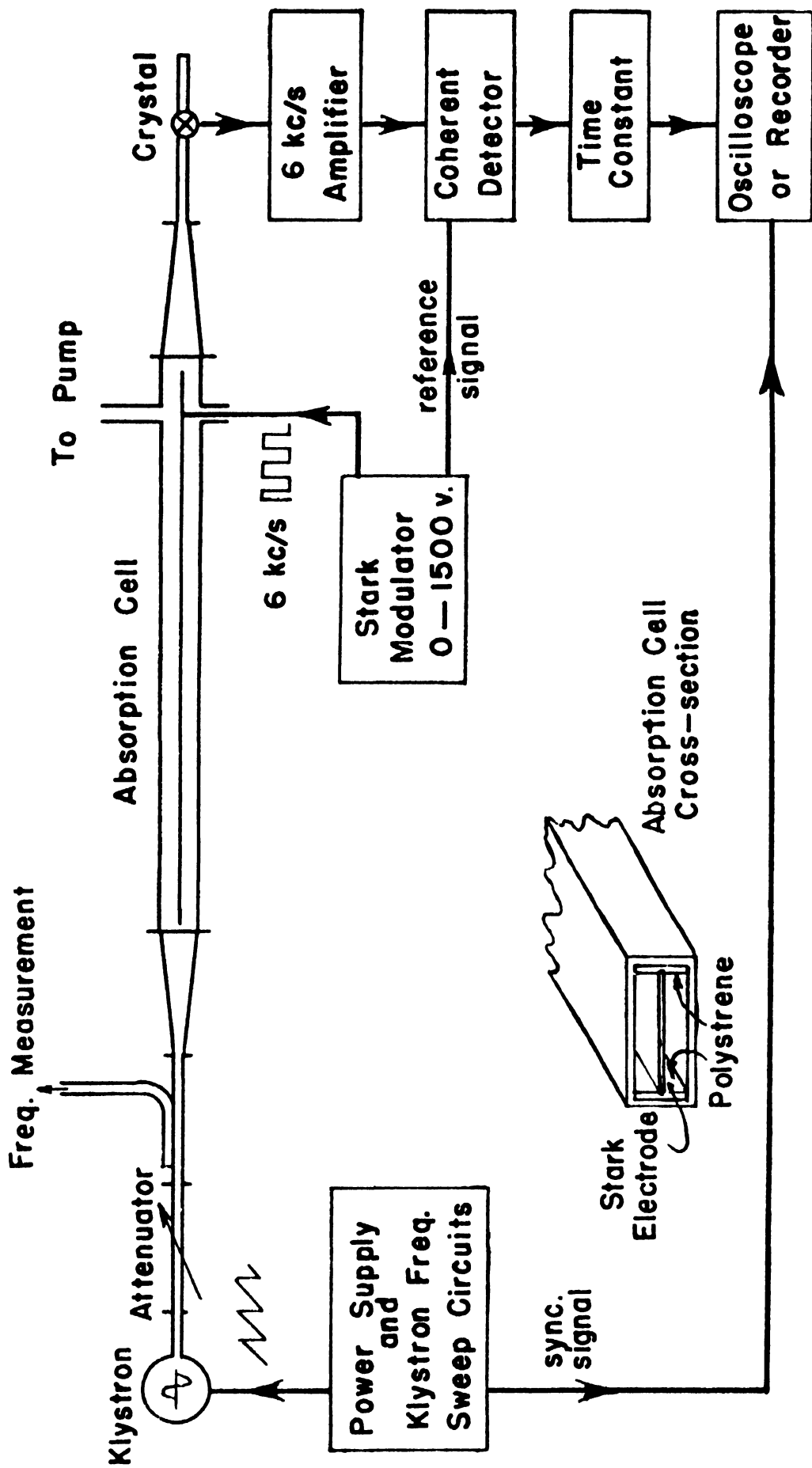

Fig. 8. Microwave spectroscopy block diagram

only if the septum deflection differs in phase from the deflection of the input end of the septum by an amount,  $2\pi l\nu/v_g$  radians, where  $v_g$  is the velocity of propagation, to account for the finite propagation time of the radiation down the cell of length  $l$ . Any other phase will give rise to a time dependent mismatch which will modulate the transmitted radiation.

There is apparently no rational solution to this problem. Fortunately, good cells can be made by maintaining a very tight fit of dielectric, waveguide, and septum. The cell must

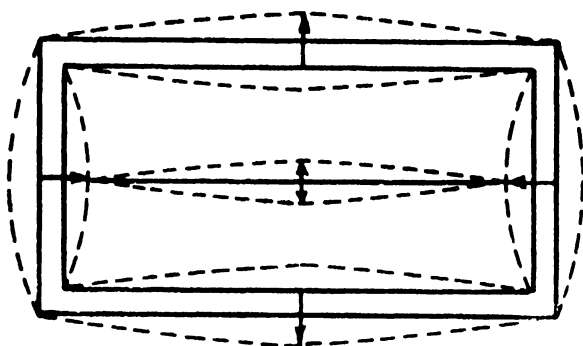

Fig. 9. Stark Cell vibration

be kept clean of small particles of metal and dust. Tapering the transition into the septum at the end of the septum, the taper being at least one acoustic wavelength of the septum vibration, has yielded suppression of the noise. This effect also becomes less important with increasing Stark modulation frequency. It seems certain that one generalization is true; that if any less symmetric placement of the septum is made, e.g., securing it to an insulating film placed on one broad wall of the guide, a large increase in guide noise is to be expected. The problem is aggravated by an increase in Stark potential. For whatever comfort it may be, it may be said that relatively noiseless cells have been made in the past by trial and error, or by luck and they presumably will be made again in the future.

There is no need to worry about electrical breakdown for with the gas mean free path the order of the minimum guide dimensions the field required for breakdown will be far above that which will ever need to be used. To obtain the required



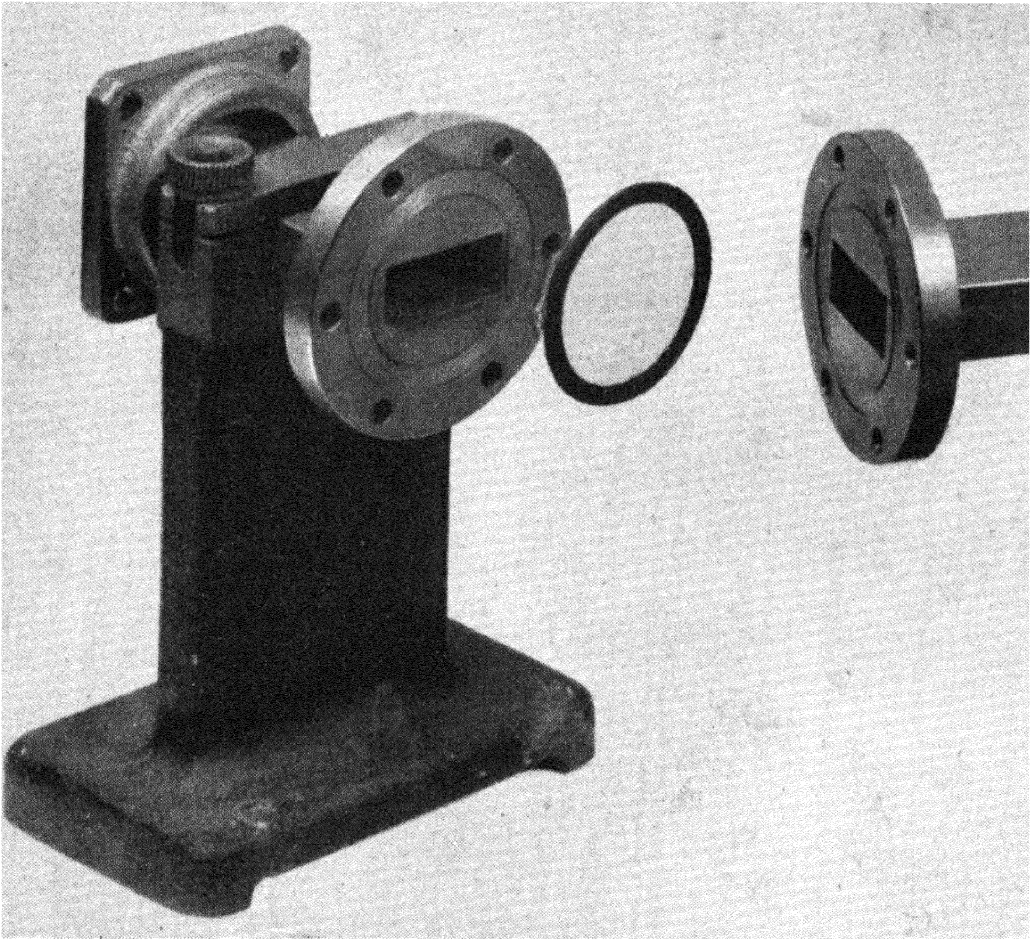

Fig. 10. Mica-lead vacuum seal

field strength with a reasonable potential the cell dimensions should not be chosen any more generously than is required for resolution purposes.

Finally, a large cross-section cell will have a small intrinsic attenuation due to wall losses. In short, if a cell is fashioned to operate at the lowest frequency contemplated, then it will have the properties desired at any higher frequency. The optimum length will be very long and decrease with increasing frequency (since  $\gamma_c$  increases with frequency). However a convenient length, several metres, is a practical length since beyond this length, increase in signal strength is paid for dearly. The cell should be straight to have smooth transmission at frequencies where more than one transmission mode is possible. Tapers must be used to make a transition from the usual  $TE_{01}$  mode in the waveguide characteristic of the source and detector for a particular frequency interval, to the same mode in the oversized sample cell. The taper angle should be small, e.g., 0.1 radians, so that higher modes excited at the junction of the taper and the cell are of negligible amplitude. Unless this is so the transfer characteristics of the cell will fluctuate rapidly with frequency as the higher modes come into resonance with the cell length.

The cell may be vacuum sealed with a thin mica sheet sealed to the guide end flanges with wax. A seal capable of low temperature cycling may be made by sealing the mica with lead clamped in grooved flanges as shown in Fig. 10.

A 3-m length of  $\frac{1}{2}$  in.  $\times$  1 in. rectangular brass tubing with a 0.020 in. thick brass septum and 0.060 in. polystyrene insulating supports is suggested as a reasonable cell. The evacuation port could be made with several  $\frac{1}{8}$  in. holes drilled in a broad wall of the guide, feeding a single  $\frac{3}{8}$  in. brass tube, which eventually connects to the vacuum system. The Stark potential is brought in through a narrow wall of the guide through a bead seal and then connected to one end of the septum which is accessible before the mica windows are installed.

## CHAPTER XIII

### DETECTORS

BOTH crystal diodes and barretters (or bolometers) which are commercially available have been suggested as detectors. From the point of view of sensitivity there is little to choose between them. Crystals, because their noise spectrum follows a  $\frac{1}{f}$  law are capable of use only with higher frequency absorption modulation, while barretters must be used with Stark modulation frequencies below about 1 kc/s, because of their thermal inertia. If a general statement governing the decision for the use of either had to be made it could be that for signal modulation frequencies below 1 kc/s a barretter should be used while for modulation above 1 kc/s a crystal should be used. A barretter is possibly to be preferred since its minimum  $\gamma$  is smaller than that for a crystal, and the optimum cell length is considerably shorter.

Crystals are slightly more durable than sensitive bolometers, which are permanently damaged by power the order of 5 to 30 mW. Crystals, however, are certainly more varied in their properties than bolometers, so some effort must be made in selecting "good" crystals on the basis of actual signal to noise observations.

The actual type of crystal or barretter, and mount is determined by the frequency region. Commercially available mounts consist essentially of a holder of the sensitive element and means for making d.c. connection to it, and means for matching the R.F. power into the detector. Match is generally achieved by a movable waveguide short circuit beyond the detector, variable in position to provide reactive matching. A screw variable in position along the guide and in depth of penetration into the radiation field is placed ahead of the detector to provide resistive matching. Such a mount can be

## CHAPTER XIV

### ELECTRONIC APPARATUS

THIS chapter will concern itself with the associated equipments such as amplifiers, presentation, Stark modulator, and power supplies, that place little or no theoretical limitation on the spectroscopist but which involve nearly all the practical details of building a reliable piece of equipment. The initial cost of these units is not great compared with the continuing cost for radiation sources and so great consideration should be given to their overdesign to assure long, carefree service and easy maintenance.

*A. Stark Modulator.* It has been indicated before that modulation of the absorption frequency by means of the Stark effect provides a convenient means of identifying the absorption in the presence of interfering signals. By "interfering signals" is meant the variation in detector output not due to resonant gas absorption. Thus the source output may be expected to vary slowly in a random fashion with time due to small changes in the source input power, or room temperature or pressure, etc. The detector output will also vary with time if the source frequency is varied due to the variation of output power with frequency, and due to the frequency dependent transmission of the cell, and finally due to the frequency sensitivity of the match into the detector. These variations will all have frequency components related simply to the rate at which the source is changed in frequency, as would the absorption signal if it were not coded by the Stark effect. The Stark modulation thus allows the absorption signal alone to be converted to a higher frequency signal, preferably of high enough frequency so that at conceivable frequency variation rates the extraneous detector output will be negligible compared to the true noise level. To avoid pickup from the power lines the frequency should be less than the mains frequency or at least ten times greater.

An upper limit to a convenient Stark frequency is set by two considerations. First, a modulation of the absorption frequency has the effect of adding side frequencies or side bands to an absorption line, separated from it by harmonics of the modulating frequency. When the modulation frequency is less than a frequency equal to the line breadth parameter  $\Delta\nu = (2\pi\tau)^{-1}$ , the side bands are small in number and low in amplitude so the net effect is to increase the line breadth by:

$$\Delta\nu_{\text{eff}} = \Delta\nu \left[ 1 + \frac{1}{4} \left( \frac{f}{\Delta\nu} \right)^2 \dots \right] \quad \text{(XIV.1)}$$

when  $f/\Delta\nu \ll 1$ . This consideration means that the modulation fundamental should be at least less than one-fourth the expected line breadth. Since a line breadth parameter  $\Delta\nu$  of 60 kc/s is achieved by a 1 in.  $\times$   $\frac{1}{2}$  in. Stark cell, a Stark modulation frequency of 15 kc/s or less should be considered. The crystal diode would have to be used for a modulation frequency as great as this, and it would be slightly better to use it at a higher modulation frequency to achieve a better value for the detector noise figure. The actual improvement is small however and the large gain in resolution should more than compensate for this loss. Note, too, that if a Stark switching frequency of less than 1 kc/s is used with a thermal detector no unnecessary loss in sensitivity need be suffered.

Since the field must be either "on" or "off" in a square wave fashion to allow perturbed lines to be established by a unique field strength, the field should be established in a time measured by about 1 per cent of the full on and off time. The establishment of the field is represented electrically by the charging of a capacitor, C, to a potential V. The charging cannot be resonant, i.e., sinusoidal, and hence it represents a total loss of electrical energy per charge and discharge cycle of  $CV^2$ . The power required is thus  $CV^2f$ , increasing proportional to the charging frequency. The modulator must be bulkier for higher switching frequencies. First, because it must be able to charge the cell in a time of about  $1/200f$

which signifies a peak current handling capacity of at least  $200fCV$ . Second, it must supply energy at a rate of  $CV^2f$ .

The actual design parameters might be taken as follows. For the switch frequency, either 10 kc/s or 700 c/s could be used for a crystal or barretter detector system, respectively. The capacity of a 1 in.  $\times$   $\frac{1}{2}$  in. cell is about 200  $\mu\mu f$  per meter. A voltage which may be readily and reasonably used is about 2500 V.

Fortunately, hydrogen thyratrons are available for use as triggered switch tubes for switching frequencies less than 15 kc/s. These tubes allow a considerable gain in efficiency and simplicity over hard tubes.

A typical design would thus consist of a multivibrator whose two anode signals are separately differentiated to yield two separate sources of positive pulses which are spaced  $180^\circ$  apart. These pulses are used to trigger two normally quiescent blocking oscillators to generate large pulses at a low impedance level. When these pulses are stretched to a few microseconds length, they may be used as triggers for thyratron switch tubes. A particular circuit is shown in Fig. 11. At switch frequencies above 15 kc/s, the thyratrons must be replaced by hard tubes, since the long hydrogen de-ionization time does not allow potentials to be applied to the thyratron sooner than about 20  $\mu\text{sec}$  after it has conducted its switching current. The circuit is readily adapted at higher frequencies through the use of hard tubes as switching elements. The necessary larger pulse grid drive voltages for hard tubes are much less convenient than the simple triggering pulses for thyratrons.

*B. Amplifier.* The signal amplifier may be considered as composed of two elements. The first is the input network, and the second is the interstage coupling filters. The input network must be designed to transform the detector impedance into an impedance at the input grid of the first amplifier tube such that the minimum additional shot noise is introduced by the first stage of the amplifier. For amplifiers of less than 1 Mc/s this is accomplished simply by transforming the detector impedance to as high a value as possible at the input grid. More precisely, for an input to a triode with a transconductance of  $g_m$  the



detector impedance should be large compared to  $3/g_m$  ohms, the equivalent shot noise resistance of a triode.

With a barretter having the usual 200-ohm resistance the input circuit is most suitably a high step-up audio transformer. Excellent audio transformers with approximately 200-ohm primaries and several tens or hundreds of kilohm secondaries are available. The transformer should be well shielded to prevent magnetic pickup of extraneous signals.

For crystals a simple transformer is not suitable since the source impedance varies violently with operating level. With a few microwatts incident on the crystal the source impedance will be about 10,000 ohm, while with a milliwatt incident on the detector the impedance will be around 300 ohm. As a simple solution the crystal may be worked directly into the grid of a triode with reasonably high  $g_m$ . At microwatt levels the crystal impedance is so large that a suitable triode will introduce no appreciable noise. At milliwatt levels the crystal impedance is so low that the first amplifier stage would introduce considerable additional noise compared to a noiseless crystal. However, since the crystal noise level is anomalously high at milliwatt levels, the first stage shot noise will not be noticed. More elegantly, a series resonant LC circuit may be used to step up the variable crystal impedance to a consistently high level. The crystal and grid terminal must be by-passed to ground for d.c. currents. This is best accomplished by using a toroidal inductance of an impedance in excess of 10,000 ohm at the signal frequency with a d.c. resistance less than 100 ohm.

The amplifier interstage filter network is most conveniently made using a twin-T feedback circuit. This arrangement is free from pickup difficulties and is simply made. Simple twin-T's have a ratio of centre frequency to band pass width of about 10. Thus a barretter amplifier at 600 c/s is conveniently made 60 c/s wide, while a crystal amplifier at 6000 c/s is about 600 c/s wide. We shall see later that these widths are sufficient to allow an absorption to be swept through at a rate of several times a second with no appreciable distortion. Such a width is convenient for absorption



coefficients the order of  $10^{-6} \text{ cm}^{-1}$  and larger, yet they are quite broad enough to allow a considerable drift of the signal modulation frequency with no significant loss in signal output. A typical amplifier design is shown in Fig. 12.

To observe smaller absorption coefficients the amplifier bandwidth must be further narrowed. Narrowing the primary amplifier would require critical circuitry and rigorous control of the Stark modulation frequency. Hence further narrowing is best accomplished by transforming the signal to zero frequency with a linear homodyne detector which uses a sample of the Stark modulation potential as a beat signal. This type of detector is variously described as a phase detector, zero beat detector, linear demodulator, or synchronous detector. The signal may now be narrowed in a stable fashion using an RC filter. The capacitor only need be changed to vary the effective bandwidth of the unit.

Some care must be taken to make a stable, linear homodyne detector. For a large bandwidth reduction the resulting filtered signal near D.C. will be small. This follows since the detector cannot be operated linearly with r.m.s. voltages above about 1 V. Thus with a bandwidth reduction of 1000, e.g., from 600 c/s wide to 0.6 c/s wide, the filtered noise signal will be less than  $(1000)^{\frac{1}{2}}$  of the input when allowance is made for detector loss. This is less than 30 mV of nearly d.c. signal, hence a detector stability of better than 0.1 mV is a necessity.

After filtering, the signal and noise are best amplified by a chopper amplifier since it is stable and the signal after amplification is conveniently applied to an oscilloscope, using a.c. coupling. The signal modulated chopper carrier has the further advantage of instantaneously defining the oscilloscope zero base line about which it is symmetrical. Following this amplification the signal may be synchronously detected again in the chopper and the resulting D.C. used to drive a recording milliammeter. A typical circuit for this de-re-de-modulation unit is shown in Fig. 13. In this unit the gain is switched with the bandwidth determining capacitor so that the r.m.s. noise voltage output is a constant.





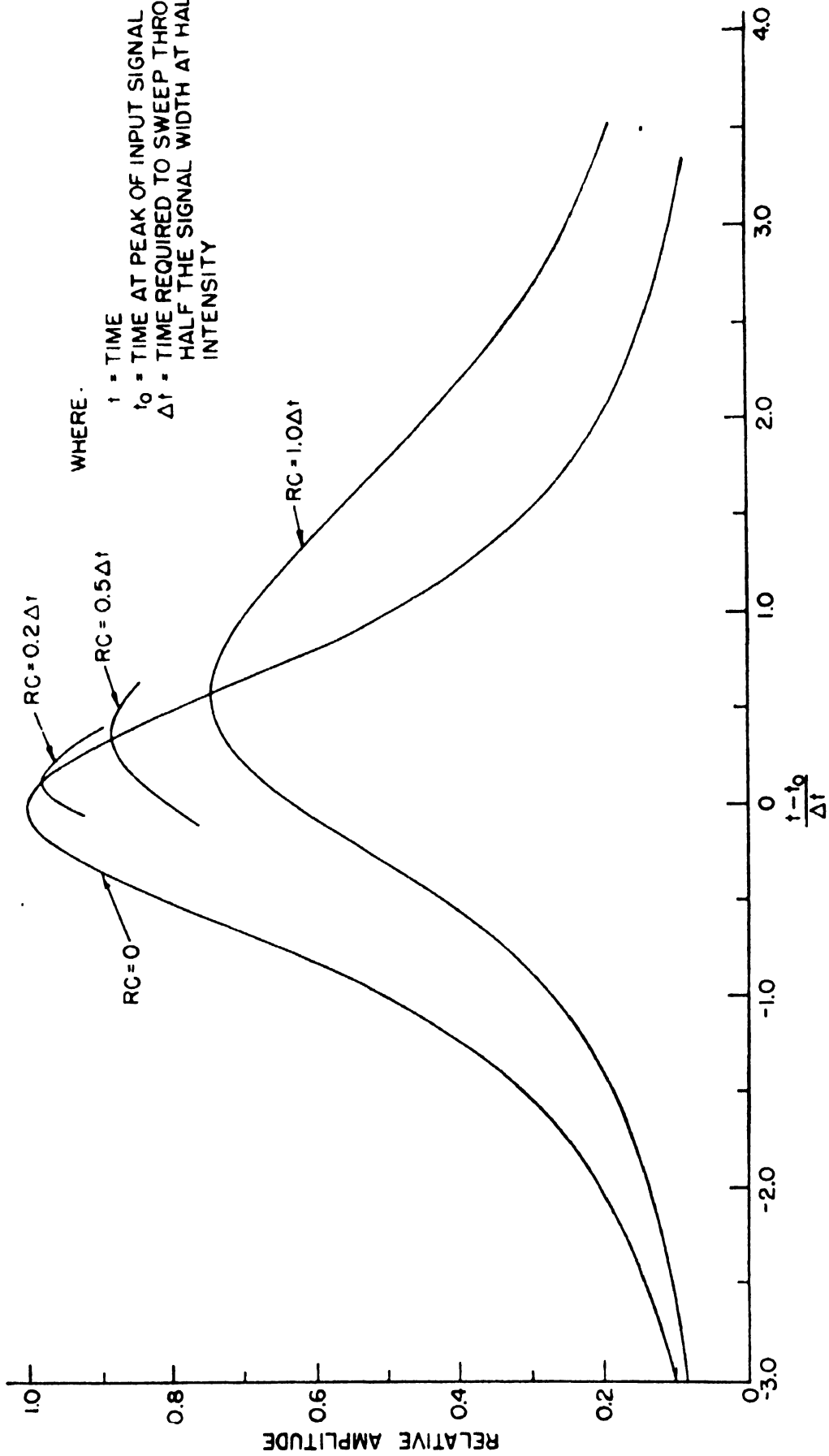

Fig. 15. Filter time-shift

by the R-C filter as  $B = \pi/RC$ . Taking  $RC = \tau$ , with an input of  $v_i(t)$ , the output across C is:

$$v_0(t) = \frac{1}{\tau} e^{-\frac{t}{\tau}} \int_0^t e^{\frac{t'}{\tau}} v_i(t') dt' \quad . \quad (XIV.2)$$

In sweeping through a resonant absorption linearly with time the input voltage is written:

$$v_i(t) = V \left[ 1 - \left( \frac{t - t_0}{\Delta t} \right)^2 \right] \quad . \quad (XIV.3)$$

where  $t_0$  is the time of passing through the peak,  $V$ ,  $\Delta t$  is the half width of the line in time. The solution of (XIV.2) and (XIV.3) may be carried out numerically and is shown in Fig. 15. For  $\Delta t > \tau$  the time shift of the line peak is  $RC$ . The frequency shift is thus:

$$v_s = \tau \frac{dv}{dt}$$

where  $\frac{dv}{dt}$  is the sweep constant.

Since  $v_0(t)$  must have a maximum where it crosses  $v_i(t)$  this time shift causes a loss in amplitude which is second order in  $RC$ . Finally, since the integrated filtered signal is independent of  $RC$ , this loss in amplitude causes an apparent line broadening.

A rule of thumb for negligible distortion is to sweep through an absorption line in about 20 to 50 filter time constants.

## BIBLIOGRAPHY

### *Chapter I*

There are so many good sources of material on the theory of quantum operators that taste must dictate choice. As examples of generally available texts, one may cite G. TEMPLE'S monograph in the Methuen series *General Principles of Quantum Theory* (Methuen, London, 1951) or V. ROJANSKY'S *Quantum Mechanics* (Prentice-Hall, New York, 1942), especially Chapters 3, 9, and 10. E. U. CONDON and G. H. SHORTLEY'S *Theory of Atomic Spectra* (Cambridge University Press, London, 1951), especially Chapters 2, 3, 4, and 9, is a basic reference book. An excellent discussion of the theory of angular momentum operators has been given by J. H. VAN VLECK in *The Reviews of Modern Physics*, **23**, 213 (1951). The recently published *Notes on the Quantum Theory of Angular Momentum* (Addison-Wesley Publishing Co., Inc., Cambridge, Mass., 1953) of E. FEENBERG and G. W. PAKE will be useful.

### *Chapter II*

H. B. G. CASIMIR'S text *Rotation of a Rigid Body in Quantum Mechanics* (J. B. Wolter's, The Hague, 1931) is not generally available, unfortunately. The best available material is in the papers and references of G. W. KING, R. M. HAINER, and P. C. CROSS in *The Journal of Chemical Physics*, **11**, 27 (1943), **17**, 826 (1949).

### *Chapter III*

The basic paper in this field is that of E. B. WILSON, Jr., and J. B. HOWARD in *The Journal of Chemical Physics*, **4**, 262 (1936), though the review paper of H. H. NIELSEN is more detailed and is certainly a source of excellent additional reference material (*Reviews of Modern Physics*, **23**, 90 (1951)). Efforts to derive an approximate form for the distortion

correction begun by P. C. CROSS, *The Physical Review*, **47**, 7 (1935), and S. GOLDEN, *The Journal of Chemical Physics*, **16**, 250 (1948), have been brought to the farthest development by D. KIVELSON and E. B. WILSON, Jr., in *The Journal of Chemical Physics*, **20**, 1575 (1952).

#### Chapter IV

Another of H. B. G. CASIMIR's texts, *On the Interaction Between Atomic Nuclei and Electrons* (Teyler's Tweede Genootschap, Haarlem, 1936), is basic in this subject. The article of J. K. BRAGG in *The Physical Review*, **74**, 533 (1948) should also be consulted. The Racah coefficients are also reviewed in *The Reviews of Modern Physics*, **24**, 249 (1952), by L. C. BIEDENHARN, J. M. BLATT, and M. E. ROSE.

#### Chapter V

There is little general material available, though the paper of S. GOLDEN and E. B. WILSON, Jr., *The Journal of Chemical Physics*, **16**, 669 (1948), is quite complete. See also, STRANDBERG, WENTINK, HILL, *The Physical Review*, **75**, 827 (1949).

#### Chapter VI

A good review of past and present theory is given in ESHBACH and STRANDBERG, *The Physical Review*, **85**, 24 (1952), and the references there cited. For the extension to include nuclear magnetic moments, see ESHBACH, HILLGER, and STRANDBERG, *The Physical Review*, **85**, 532, 1952.

#### Chapter VII

There is little material available, see CASIMIR, *loc. cit.*, Chapter II, above; see also, JOHNSON and STRANDBERG, *The Journal of Chemical Physics*, **20**, 687 (1952).

#### Chapter VIII

For a fine treatment of the general properties of the density matrix see R. C. TOLMAN, *Principles of Statistical Mechanics*, Chapter IX (Oxford University Press, Oxford, 1938), and P. A. M. DIRAC, *Proceedings of the Cambridge Philosophical*

*Society*, **25**, 62 (1929). The elegant paper of R. KARPLUS and J. SCHWINGER, *The Physical Review*, **73**, 1020 (1948), should be cited as the basis of this chapter. For a different approach to these types of calculations see H. R. JOHNSON and M. W. P. STRANDBERG in *The Physical Review*, **86**, 811 (1952). For a treatment of generalized interaction potentials, see P. W. ANDERSON, *The Physical Review*, **76**, 647 (1949).

### *Chapter IX*

There is much material on oxygen and ammonia. For a general treatment it is best to cite H. A. KRAMERS' *Zeits. f. Physik*, **53**, 422 (1929), and R. SCHLAPP, *The Physical Review*, **51**, 342 (1937).

The ammonia inversion splitting has been treated many times in many ways. See R. R. NEWTON and L. A. THOMAS's paper in *The Journal of Chemical Physics*, **16**, 310 (1948) for a good exposition and many references.

### *Chapters X to XIV*

Of the many good microwave texts the monographs in the Methuen series by R. L. LAMONT, *Wave Guides* (1950), and H. MOTZ, *Electromagnetic Problems of Microwave Theory* (1951), are examples. The Radiation Laboratory series (McGraw-Hill, New York) contains much basic information and all twenty-seven volumes are of some use. See especially Volume 7, *Klystrons and Microwave Triodes*, Chapter 17; Volume 11, *Techniques of Microwave Measurements*; Volume 15, *Crystal Rectifiers*; and Volume 16, *Microwave Mixers*.

### *General*

The tables of C. H. TOWNES and P. KISLIUK form a very useful reference to observed spectra: *Molecular Microwave Spectra Tables*, National Bureau of Standards Circular 518 (U.S. Government Printing Office, Washington, D.C., 1952).

## APPENDIX I

### TABLE OF REDUCED ENERGY

*(Reprinted by permission of G. W. King, R. M. Hainer and P. C. Cross, and the American Institute of Physics, from "The Journal of Chemical Physics," 11, 27 (1943), 17, 826 (1949))*

THE asymmetry parameter  $\kappa = (2b - a - c)/(a - c)$ , where  $a, b, c$  equal  $h/8\pi^2 I_a, h/8\pi^2 I_b, h/8\pi^2 I_c$ , and  $a > b > c$ .

Reduced energies for  $0 \leq \kappa \leq 1$  may be obtained from the table by use of the relation  $E_{\tau}^J(\kappa) = -E_{-\tau}^J(-\kappa)$ .

Rotational energy levels are given by

$$W_{\tau}^J(a, b, c) = [(a + c)/2]J(J + 1)h - [(a - c)/2]E_{\tau}^J(\kappa)h$$

$J_{K_1, K_1}$	$\delta$	0	0.05	0.1	0.15	0.2	0.25	0.3	0.35	0.4	0.45	0.5	$\delta$
	$\kappa-1$	-0.9	-0.8	-0.7	-0.6	-0.5	-0.4	-0.3	-0.2	-0.1	0	0	$\kappa$
0 <sub>0,0</sub>	0	0	0	0	0	0	0	0	0	0	0	0	0 <sub>0</sub>
1 <sub>1,0</sub>	0	0.1	0.2	0.3	0.4	0.5	0.6	0.7	0.8	0.9	1	1	1 <sub>1</sub>
1 <sub>1,1</sub>	0	0	0	0	0	0	0	0	0	0	0	0	1 <sub>0</sub>
1 <sub>0,1</sub>	-2	-1.9	-1.8	-1.7	-1.6	-1.5	-1.4	-1.3	-1.2	-1.1	-1	-1	1 <sub>-1</sub>
2 <sub>2,0</sub>	2	2.10384	2.21576	2.33631	2.46606	2.60555	2.75528	2.91568	3.08712	3.26987	3.46410	3.66987	2 <sub>2</sub>
2 <sub>2,1</sub>	2	2.1	2.2	2.3	2.4	2.5	2.6	2.7	2.8	2.9	3	3	2 <sub>1</sub>
2 <sub>1,1</sub>	-4	-3.6	-3.2	-2.8	-2.4	-2.0	-1.6	-1.2	-0.8	-0.4	0	0	2 <sub>0</sub>
2 <sub>1,2</sub>	-4	-3.9	-3.8	-3.7	-3.6	-3.5	-3.4	-3.3	-3.2	-3.1	-3	-3	2 <sub>-1</sub>
2 <sub>0,2</sub>	-6	-5.70384	-5.41576	-5.13631	-4.86506	-4.60555	-4.35528	-4.11568	-3.88712	-3.66987	-3.46410	-3.26987	2 <sub>-2</sub>
3 <sub>3,0</sub>	6	6.15245	6.31027	6.47424	6.64530	6.82456	7.01332	7.21314	7.42586	7.65364	7.89898	8.16176	3 <sub>3</sub>
3 <sub>3,1</sub>	6	6.15236	6.30949	6.47147	6.63837	6.81025	6.98717	7.16917	7.35629	7.54855	7.74597	7.94855	3 <sub>2</sub>
3 <sub>2,1</sub>	-4	-3.58082	-3.12186	-2.62186	-2.08082	-1.5	-0.88175	-0.22917	0.45421	1.16476	1.89898	2.65364	3 <sub>1</sub>
3 <sub>2,2</sub>	-4	-3.6	-3.2	-2.8	-2.4	-2.0	-1.6	-1.2	-0.8	-0.4	0	0	3 <sub>0</sub>
3 <sub>1,2</sub>	-10	-9.15245	-8.31027	-7.47424	-6.64530	-5.82456	-5.01332	-4.21314	-3.42586	-2.65364	-1.89898	-1.16176	3 <sub>-1</sub>
3 <sub>1,3</sub>	-10	-9.75236	-9.50949	-9.27147	-9.03837	-8.81025	-8.58717	-8.36917	-8.15629	-7.94855	-7.74597	-7.54855	3 <sub>-2</sub>
3 <sub>0,3</sub>	-12	-11.41918	-10.87814	-10.37814	-9.91918	-9.5	-9.11325	-8.77083	-8.45421	-8.16476	-7.89898	-7.65364	3 <sub>-3</sub>
4 <sub>4,0</sub>	12	12.20299	12.41230	12.62852	12.85233	13.08461	13.32641	13.57912	13.84441	14.12449	14.42221	14.73883	4 <sub>4</sub>
4 <sub>4,1</sub>	12	12.20299	12.41227	12.62834	12.85173	13.08301	13.32279	13.57174	13.83056	14.10000	14.38083	14.67388	4 <sub>3</sub>
4 <sub>3,1</sub>	-2	-1.43958	-0.85577	-0.24426	0.40000	1.08276	1.81033	2.5928	3.42587	4.32541	5.29150	6.33083	4 <sub>2</sub>
4 <sub>3,2</sub>	-2	-1.44022	-0.86120	-0.26350	0.35224	0.98528	1.63481	2.30000	2.97998	3.67388	4.38083	5.13083	4 <sub>1</sub>
4 <sub>2,2</sub>	-12	-11.14570	-10.18216	-9.11536	-7.95859	-6.72860	-5.44216	-4.11432	-2.75776	-1.38320	0.00000	1.38320	4 <sub>0</sub>
4 <sub>2,3</sub>	-12	-11.20299	-10.41227	-9.62834	-8.85173	-8.08301	-7.32279	-6.57174	-5.83056	-5.10000	-4.38083	-3.67388	4 <sub>-1</sub>
4 <sub>1,3</sub>	-18	-16.56042	-15.14423	-13.75574	-12.40000	-11.09276	-9.81033	-8.56928	-7.42587	-6.32541	-5.29150	-4.33083	4 <sub>-2</sub>
4 <sub>1,4</sub>	-18	-17.55978	-17.13880	-16.73650	-16.35224	-15.98528	-15.63481	-15.30000	-14.97998	-14.67388	-14.38083	-14.13083	4 <sub>-3</sub>
4 <sub>0,4</sub>	-20	-19.05729	-18.23015	-17.51316	-16.89374	-16.35601	-15.88425	-15.46480	-15.09225	-14.74129	-14.42221	-14.13083	4 <sub>-4</sub>

$J_{K-1, K_1}$	$\delta$	0	0.05	0.1	0.15	0.2	0.25	0.3	0.35	0.4	0.45	0.5	$\delta$
	$\kappa$	-1	-0.9	-0.8	-0.7	-0.6	-0.5	-0.4	-0.3	-0.2	-0.1	0	$\kappa$
5 <sub>2,0</sub>	20	20.25361	20.78427	20.51481	20.78427	21.06273	21.35107	21.65036	21.96188	22.28725	22.62851	22.98829	5 <sub>5</sub>
5 <sub>3,1</sub>	20	20.25361	20.78426	20.51481	20.78426	21.06267	21.35092	21.64990	21.96077	22.28477	22.62338	22.97825	5 <sub>4</sub>
5 <sub>4,2</sub>	2	2.71155	4.21049	3.44756	4.21049	5.00354	5.83082	6.69763	7.61079	8.57900	9.61304	10.72586	5 <sub>2</sub>
5 <sub>4,2</sub>	2	2.71153	4.20892	3.44727	4.20892	4.99818	5.81665	6.66583	7.54704	8.46136	9.40961	10.39230	5 <sub>2</sub>
5 <sub>4,2</sub>	12	10.92537	9.58944	9.79317	9.58944	7.29895	5.90702	4.40221	2.77918	1.04053	0.80359	2.73757	5 <sub>1</sub>
5 <sub>4,3</sub>	12	10.92796	8.66510	9.81475	8.66510	7.48387	6.27602	5.04632	3.79947	2.53993	1.27204	0.00000	5 <sub>0</sub>
5 <sub>4,3</sub>	22	20.37904	17.09089	18.92805	17.09089	15.12406	13.07747	10.98945	8.88912	6.80000	4.74287	2.73757	5 <sub>-1</sub>
5 <sub>4,4</sub>	22	20.71153	18.20892	19.44727	18.20892	16.99818	15.81665	14.66583	13.54704	12.46136	11.40961	10.39230	5 <sub>-2</sub>
5 <sub>4,4</sub>	28	25.82824	23.72164	23.72164	23.72164	19.76378	17.94405	16.24815	14.68270	13.24472	11.93210	10.75286	5 <sub>-3</sub>
5 <sub>4,5</sub>	28	27.32565	26.70006	26.70006	26.70006	25.67880	25.07490	24.60358	24.16130	23.74484	23.35134	22.97825	5 <sub>-4</sub>
5 <sub>4,5</sub>	30	28.63251	27.51951	27.51951	27.51951	25.87948	25.25335	24.70818	24.22167	23.77900	23.37017	22.98829	5 <sub>-5</sub>
6 <sub>4,0</sub>	30	30.30423	30.94020	30.61738	30.94020	31.27357	31.61849	31.97615	32.34798	32.73589	33.14140	33.56782	6 <sub>6</sub>
6 <sub>4,1</sub>	30	30.30423	30.94020	30.61738	30.94020	31.27357	31.61847	31.97610	32.34782	32.73527	33.14039	33.56554	6 <sub>5</sub>
6 <sub>4,1</sub>	8	8.86322	10.67572	9.75433	10.67572	11.63026	12.62142	13.65350	14.73201	15.86409	17.05926	18.33030	6 <sub>4</sub>
6 <sub>4,2</sub>	8	8.86322	10.67561	9.75431	10.67561	11.62975	12.61966	13.64861	14.72012	15.83798	17.00616	18.23865	6 <sub>3</sub>
6 <sub>4,2</sub>	10	8.67533	5.86179	7.29809	5.86179	4.35735	2.77237	1.09071	0.70756	2.64470	4.74200	7.01437	6 <sub>2</sub>
6 <sub>4,3</sub>	10	8.67542	5.86955	7.29951	5.86955	4.38365	2.84099	1.24202	0.41154	2.11663	3.86897	5.66311	6 <sub>1</sub>
6 <sub>4,3</sub>	24	22.30159	20.48431	20.48431	20.48431	18.51309	16.35698	14.00000	11.44897	8.73201	5.88946	0.00000	6 <sub>0</sub>
6 <sub>4,4</sub>	24	22.30932	20.54826	20.54826	20.54826	18.73335	16.88024	15.00321	13.11511	11.23733	9.35010	7.49261	6 <sub>-1</sub>
6 <sub>4,4</sub>	34	31.86770	29.33128	29.33128	29.33128	26.53637	23.61166	20.64988	17.71113	14.84213	12.08230	9.46494	6 <sub>-2</sub>
6 <sub>4,5</sub>	34	32.12881	30.31787	30.31787	30.31787	28.57065	26.88992	25.27748	23.73408	22.25936	20.85190	19.50936	6 <sub>-3</sub>
6 <sub>4,5</sub>	40	36.96163	34.07002	34.07002	34.07002	31.36263	28.87328	26.62142	24.60453	22.80000	21.17463	19.69445	6 <sub>-4</sub>
6 <sub>4,5</sub>	40	39.05391	37.44226	37.44226	37.44226	36.74951	36.11645	35.53350	34.99279	34.48788	34.01355	33.56554	6 <sub>-5</sub>
6 <sub>4,5</sub>	42	40.16120	38.78801	38.78801	38.78801	37.74304	36.90456	36.19624	35.57431	35.01341	34.49809	33.56782	6 <sub>-6</sub>
7 <sub>4,0</sub>	42	42.35486	42.71997	42.71997	42.71997	43.09619	43.48453	43.88013	44.30286	44.73481	45.18543	45.65657	7 <sub>7</sub>
7 <sub>4,1</sub>	42	42.35486	42.71997	42.71997	42.71997	43.09619	43.48453	43.88013	44.30285	44.73479	45.18537	45.65633	7 <sub>6</sub>
7 <sub>4,1</sub>	16	17.01500	18.06163	18.06163	18.06163	19.14256	20.26091	21.42032	22.62515	23.88066	25.19347	26.57205	7 <sub>5</sub>
7 <sub>4,2</sub>	16	17.01500	18.06162	18.06162	18.06162	19.14255	20.26087	21.42031	22.62446	23.87866	25.18825	26.55961	7 <sub>4</sub>
7 <sub>4,2</sub>	6	4.42312	2.78954	2.78954	2.78954	0.66943	2.50949	4.43711	6.46744	8.62113	10.92575	13.41608	7 <sub>3</sub>
7 <sub>4,3</sub>	6	4.42313	2.78962	2.78962	2.78962	0.66638	2.49918	4.40873	6.39965	8.47556	10.63855	12.88860	7 <sub>2</sub>
7 <sub>4,3</sub>	24	21.95606	19.81731	19.81731	19.81731	17.56836	15.18906	12.63901	9.88997	6.90390	3.66093	0.16798	7 <sub>1</sub>
7 <sub>4,4</sub>	24	21.95636	19.82250	19.82250	19.82250	17.59639	15.27966	12.87783	10.40000	7.85829	5.26703	0.00000	7 <sub>0</sub>
7 <sub>4,4</sub>	38	35.56370	32.90450	32.90450	32.90450	29.95229	26.67345	23.09517	19.29241	15.35524	11.36816	7.40649	7 <sub>-1</sub>
7 <sub>4,5</sub>	38	35.58293	33.06125	33.06125	33.06125	30.47630	27.86342	25.25166	22.66461	20.12130	17.63993	15.22320	7 <sub>-2</sub>
7 <sub>4,5</sub>	48	44.99890	41.38121	41.38121	41.38121	37.47756	33.51139	29.61371	25.87353	22.35690	19.10561	16.13111	7 <sub>-3</sub>
7 <sub>4,5</sub>	48	45.45864	43.03912	43.03912	43.03912	40.74616	38.58120	36.54230	34.62446	32.82037	31.12122	29.51757	7 <sub>-4</sub>

7 <sub>4,4</sub>	-38	-35.56370	-32.90450	-29.95229	-26.67345	-23.09517	-19.29241	-15.35524	-11.36816	-7.40649	-3.53957	7 <sub>-1</sub>
7 <sub>4,5</sub>	-38	-35.58293	-33.06125	-30.47630	-27.86342	-25.25166	-22.66461	-20.12130	-17.63693	-15.22320	-12.88860	7 <sub>-2</sub>
7 <sub>4,6</sub>	-48	-44.99890	-41.38121	-37.47756	-33.51139	-29.61371	-25.87553	-22.35690	-19.10361	-16.13111	-13.41608	7 <sub>-3</sub>
7 <sub>4,6</sub>	-48	-45.45864	-43.03912	-40.74616	-38.58120	-36.54230	-34.62446	-32.82037	-31.12122	-29.51757	-28.00000	7 <sub>-4</sub>
7 <sub>1,6</sub>	-54	-49.96804	-46.22593	-42.84975	-39.88051	-37.30045	-35.04706	-33.04701	-31.23840	-29.57583	-28.02767	7 <sub>-5</sub>
7 <sub>1,7</sub>	-54	-52.74891	-51.66910	-50.72509	-49.88749	-49.13365	-48.44647	-47.81314	-47.22400	-46.67173	-46.15066	7 <sub>-6</sub>
7 <sub>6,7</sub>	-56	-53.66004	-52.06311	-50.89664	-49.96344	-49.16761	-48.46165	-47.81986	-47.22692	-46.67296	-46.15116	7 <sub>-7</sub>
8 <sub>4,9</sub>	56	56.40550	56.82257	57.25221	57.69554	58.15386	58.62871	59.12189	59.63558	60.17242	60.73566	8 <sub>4</sub>
8 <sub>4,1</sub>	56	56.40550	56.82257	57.25221	57.69554	58.15386	58.62871	59.12189	59.63557	60.17238	60.73555	8 <sub>7</sub>
8 <sub>4,1</sub>	26	27.16683	28.36913	29.60991	30.89263	32.22133	33.60075	35.03654	36.53557	38.10638	39.75991	8 <sub>4</sub>
8 <sub>4,2</sub>	26	27.16683	28.36913	29.60991	30.89263	32.22131	33.60066	35.03622	36.53460	38.10367	39.76292	8 <sub>4</sub>
8 <sub>4,2</sub>	0	1.82951	3.72124	5.69052	7.71361	9.82803	12.03308	14.34073	16.76690	19.33369	22.07216	8 <sub>4</sub>
8 <sub>4,3</sub>	0	1.82951	3.72123	5.68047	7.71330	9.82667	12.02844	14.32726	16.73241	19.25327	21.89558	8 <sub>7</sub>
8 <sub>4,3</sub>	-22	-19.60431	-17.11206	-14.51381	-11.79659	-8.94181	-5.92261	-2.70132	0.77076	4.54704	8.66888	8 <sub>4</sub>
8 <sub>4,4</sub>	-22	-19.60432	-17.11240	-14.51661	-11.80954	-8.98498	-6.03922	-2.97225	0.21113	3.50079	6.88121	8 <sub>1</sub>
8 <sub>4,4</sub>	-40	-37.12871	-34.10050	-30.88066	-27.41611	-23.64282	-19.50903	-15.00742	-10.18985	-5.15070	0.00000	8 <sub>9</sub>
8 <sub>4,5</sub>	-40	-37.12961	-34.11595	-30.96275	-27.68384	-24.30158	-20.84414	-17.34256	-13.82839	-10.33195	-6.88121	8 <sub>-1</sub>
8 <sub>4,5</sub>	-54	-50.70574	-47.02209	-42.84192	-38.18998	-33.21092	-28.07787	-22.94146	-17.92750	-13.14274	-8.66888	8 <sub>-2</sub>
8 <sub>4,6</sub>	-54	-50.74775	-47.35653	-43.91096	-40.47535	-37.09670	-33.80861	-30.63410	-27.58741	-24.07532	-21.89857	8 <sub>-3</sub>
8 <sub>4,6</sub>	-64	-59.96219	-55.08643	-49.97556	-44.94942	-40.18548	-35.79447	-31.82321	-28.25352	-25.02598	-22.07216	8 <sub>-4</sub>
8 <sub>4,7</sub>	-64	-60.70539	-57.62785	-54.76993	-52.12499	-49.67895	-47.41301	-45.30659	-43.33959	-41.49370	-39.75292	8 <sub>-5</sub>
8 <sub>4,7</sub>	-70	-64.85679	-60.23498	-56.25418	-52.90606	-50.06860	-47.60027	-45.39376	-43.37883	-41.51068	-39.75991	8 <sub>-6</sub>
8 <sub>4,8</sub>	-70	-68.41477	-67.10020	-65.98234	-65.00774	-64.13963	-63.35283	-62.62987	-61.95832	-61.32914	-60.73555	8 <sub>-7</sub>
8 <sub>4,8</sub>	-72	-69.14410	-67.35688	-66.07651	-65.04361	-64.15359	-63.35829	-62.63199	-61.95912	-61.32943	-60.73566	8 <sub>-8</sub>
9 <sub>4,9</sub>	72	72.45613	72.92518	73.40825	73.90658	74.42165	74.95515	75.50910	76.08592	76.68854	77.32058	9 <sub>4</sub>
9 <sub>4,1</sub>	72	72.45613	72.92518	73.40825	73.90658	74.42165	74.95515	75.50910	76.08591	76.68853	77.32056	9 <sub>4</sub>
9 <sub>4,1</sub>	38	39.31868	40.67675	42.07753	43.52486	45.02921	46.57781	48.19485	49.88181	51.64782	53.50433	9 <sub>7</sub>
9 <sub>4,2</sub>	38	39.31868	40.67675	42.07753	43.52486	45.02921	46.57780	48.19481	49.88164	51.64726	53.50266	9 <sub>4</sub>
9 <sub>7,2</sub>	8	10.08234	12.23284	14.45731	16.76247	19.15619	21.64787	24.24891	26.97372	29.84111	32.87689	9 <sub>4</sub>
9 <sub>7,3</sub>	8	10.08234	12.23284	14.45731	16.76244	19.15603	21.64717	24.24648	26.96631	29.82081	32.82376	9 <sub>4</sub>
9 <sub>4,3</sub>	-18	-15.25136	-12.40015	-9.43737	-6.35217	-3.13080	0.24515	3.80150	7.57555	11.62086	16.00923	9 <sub>4</sub>
9 <sub>4,4</sub>	-18	-15.25136	-12.40016	-9.43761	-6.35370	-3.13740	0.22283	3.73803	7.41715	11.26493	15.27959	9 <sub>4</sub>

$J_{K-1, K_1}$	$\delta$	0	0.05	0.1	0.15	0.2	0.25	0.3	0.35	0.4	0.45	0.5	$\delta$
	$r-1$												$\kappa$
9 <sub>4,4</sub>	-40	-36.67904	-33.20766	-29.56890	-25.73632	-21.66848	-17.30456	-12.36784	-7.38796	-1.74182	4.31610	9 <sub>1</sub>	
9 <sub>4,5</sub>	-48	-36.67907	-33.20883	-29.57856	-25.78034	-21.81221	-17.68086	-13.40321	-9.00616	-4.52484	0.00000	9 <sub>6</sub>	
9 <sub>4,6</sub>	-58	-54.19095	-50.13492	-45.75802	-40.95556	-35.63960	-29.81240	-23.58911	-17.14554	-10.66402	-4.31610	9 <sub>-1</sub>	
9 <sub>4,6</sub>	-58	-54.19330	-50.17453	-45.96402	-41.60316	-37.14601	-32.65039	-28.17155	-23.75826	-19.45078	-15.27959	9 <sub>-2</sub>	
9 <sub>4,6</sub>	-72	-67.72006	-62.80114	-57.13928	-50.92760	-44.49261	-38.07036	-31.89729	-26.11873	-20.82173	-16.00923	9 <sub>-3</sub>	
9 <sub>4,7</sub>	-72	-67.80326	-63.44066	-59.06273	-54.76962	-50.62458	-46.66453	-42.90671	-39.63371	-35.99794	-32.82576	9 <sub>-4</sub>	
9 <sub>4,7</sub>	-82	-76.75116	-70.47091	-64.10763	-58.08138	-52.60633	-47.75172	-43.60633	-39.61925	-36.11803	-32.87689	9 <sub>-4</sub>	
9 <sub>4,5</sub>	-82	-77.87402	-74.10206	-70.67590	-67.50800	-64.73980	-62.15024	-59.76129	-57.34053	-55.46141	-53.50266	9 <sub>-6</sub>	
9 <sub>4,8</sub>	-88	-81.63937	-76.14922	-71.65838	-68.00313	-64.92675	-62.22810	-59.79293	-57.55295	-55.46610	-53.50433	9 <sub>-7</sub>	
9 <sub>4,9</sub>	-88	-86.05614	-84.50853	-83.22427	-82.11906	-81.14089	-80.25693	-79.44596	-78.69235	-77.98656	-77.32056	9 <sub>-8</sub>	
9 <sub>4,9</sub>	-90	-86.62521	-84.67077	-83.27451	-82.13555	-81.14648	-80.25884	-79.44631	-78.69257	-77.98663	-77.32058	9 <sub>-9</sub>	
10 <sub>6,0</sub>	90	90.50677	91.02780	91.56430	92.11765	92.68947	93.28164	93.89638	94.53636	95.20481	95.90573	10 <sub>10</sub>	
10 <sub>6,1</sub>	90	90.50677	91.02780	91.56430	92.11765	92.68947	93.28164	93.89638	94.53636	95.20481	95.90573	10 <sub>6</sub>	
10 <sub>6,1</sub>	52	53.47056	54.98444	56.54530	58.15739	59.82560	61.55565	63.35435	65.22987	67.19213	69.25347	10 <sub>6</sub>	
10 <sub>6,2</sub>	52	53.47056	54.98444	56.54530	58.15739	59.82560	61.55564	63.35434	65.22984	67.19202	69.25308	10 <sub>7</sub>	
10 <sub>6,2</sub>	18	20.33528	22.74489	25.23517	27.81341	30.48810	33.26924	36.16881	39.20139	42.38529	45.74432	10 <sub>6</sub>	
10 <sub>6,3</sub>	18	20.33527	22.74489	25.23517	27.81341	30.48808	33.26914	36.16840	39.19991	42.38053	45.73037	10 <sub>6</sub>	
10 <sub>6,3</sub>	-12	-8.89789	-5.68393	-2.35463	1.10694	4.71202	8.47676	12.42191	16.57564	20.97829	25.68964	10 <sub>4</sub>	
10 <sub>6,4</sub>	-12	-8.89789	-5.68593	-2.35468	1.10677	4.71111	8.47295	12.40876	16.53640	20.87367	25.43593	10 <sub>3</sub>	
10 <sub>6,4</sub>	-38	-34.22662	-30.29839	-26.20121	-21.91700	-17.42058	-12.67461	-7.62217	-2.18038	3.75474	10.27364	10 <sub>6</sub>	
10 <sub>6,5</sub>	-38	-34.22663	-30.29846	-26.20216	-21.92298	-17.44611	-12.75906	-7.85527	-2.73819	2.57523	8.05291	10 <sub>1</sub>	
10 <sub>6,5</sub>	-60	-55.64584	-51.06976	-46.24088	-41.10481	-35.57302	-29.32245	-22.88752	-15.64523	-7.94325	0.00000	10 <sub>6</sub>	
10 <sub>6,6</sub>	-60	-55.64594	-51.07323	-46.26924	-41.23155	-35.97438	-30.53144	-24.95372	-19.30370	-13.64837	-8.05291	10 <sub>-1</sub>	
10 <sub>6,6</sub>	-78	-73.14002	-67.90347	-62.14553	-55.70142	-48.53948	-40.84180	-32.89913	-24.99790	-17.38950	-10.27364	10 <sub>-2</sub>	
10 <sub>6,7</sub>	-78	-73.14548	-67.99406	-62.60214	-57.06078	-51.47118	-45.92680	-40.50444	-35.26085	-30.23225	-25.43593	10 <sub>-3</sub>	
10 <sub>6,7</sub>	-92	-86.59725	-80.20810	-72.83972	-64.98059	-57.11839	-49.60411	-42.67271	-36.41928	-30.79761	-25.68964	10 <sub>-4</sub>	
10 <sub>6,8</sub>	-92	-86.74965	-81.32404	-75.96389	-70.80642	-65.92196	-61.33674	-57.04805	-53.03606	-49.27319	-45.73037	10 <sub>-5</sub>	
10 <sub>6,8</sub>	-102	-95.36420	-87.56942	-79.96900	-73.07902	-67.07495	-61.87341	-57.28235	-53.13293	-49.31110	-45.74432	10 <sub>-6</sub>	
10 <sub>6,9</sub>	-102	-96.96993	-92.48017	-88.49517	-84.94730	-81.76026	-78.86492	-76.20507	-73.73723	-71.42832	-69.25308	10 <sub>-7</sub>	
10 <sub>6,9</sub>	-108	-100.32958	-94.02065	-89.11005	-85.17893	-81.84560	-78.89585	-76.21603	-73.74100	-71.42956	-69.25347	10 <sub>-8</sub>	
10 <sub>6,10</sub>	-108	-105.67708	-103.90124	-102.45750	-101.22619	-100.14037	-99.16041	-98.26134	-97.42648	-96.64413	-95.90573	10 <sub>-9</sub>	
10 <sub>6,10</sub>	-110	-106.11121	-104.00141	-102.48373	-101.23362	-100.14256	-99.16106	-98.26154	-97.42654	-96.64415	-95.90573	10 <sub>-10</sub>	

110.0	110.55741	111.13042	111.72035	112.32873	112.93732	113.60817	114.28371	114.98687	115.72118	116.49101	11.11
110.1	110.55741	111.13042	111.72035	112.32873	112.93732	113.60817	114.28371	114.98687	115.72118	116.49101	11.10
110.2	69.62244	71.29217	73.01320	74.79013	76.62830	78.53399	80.51437	82.57895	84.73792	87.00484	11.9
110.3	69.62244	71.29217	73.01320	74.79013	76.62830	78.53399	80.51437	82.57895	84.73792	87.00476	11.8
110.4	32.58229	35.25722	38.01369	40.86557	43.82203	46.89387	50.09389	53.43757	56.94391	60.63395	11.7
110.5	32.58229	35.25722	38.01369	40.86557	43.82203	46.89387	50.09389	53.43757	56.94391	60.63395	11.6
110.6	-0.54413	3.02952	6.73101	10.37202	14.06612	17.79935	23.08058	27.64194	32.43881	37.57816	11.5
110.7	-0.54413	3.02952	6.73101	10.37202	14.06612	17.79935	23.08058	27.64194	32.43881	37.57816	11.4
110.8	29.77306	25.38384	20.51819	16.05925	11.08615	5.87160	-0.37697	5.45566	11.71501	18.52846	11.3
110.9	29.77306	25.38384	20.51819	16.05925	11.08615	5.87160	-0.37697	5.45566	11.71501	18.52846	11.2
111.0	55.09517	40.96384	24.59948	8.95660	-32.93222	-66.62830	-99.67528	-129.2873	-156.07554	-179.07639	12.10
111.1	55.09517	40.96384	24.59948	8.95660	-32.93222	-66.62830	-99.67528	-129.2873	-156.07554	-179.07639	12.10
111.2	55.09517	40.96384	24.59948	8.95660	-32.93222	-66.62830	-99.67528	-129.2873	-156.07554	-179.07639	12.10
111.3	76.30333	70.69043	64.57838	58.15601	51.48395	44.64197	37.73949	30.57020	23.12921	15.52846	11.1
111.4	76.30333	70.69043	64.57838	58.15601	51.48395	44.64197	37.73949	30.57020	23.12921	15.52846	11.2
111.5	89.9251	87.38951	84.57242	81.37141	77.90522	74.12851	70.04668	65.72135	61.19352	57.00476	11.1
111.6	89.9251	87.38951	84.57242	81.37141	77.90522	74.12851	70.04668	65.72135	61.19352	57.00476	11.2
111.7	107.58790	101.02059	94.65135	88.64681	83.66597	79.22052	75.15043	71.32203	67.70203	64.34210	11.1
111.8	107.58790	101.02059	94.65135	88.64681	83.66597	79.22052	75.15043	71.32203	67.70203	64.34210	11.2
111.9	115.80441	106.42499	96.67766	88.64681	83.66597	79.22052	75.15043	71.32203	67.70203	64.34210	11.1
112.0	115.80441	106.42499	96.67766	88.64681	83.66597	79.22052	75.15043	71.32203	67.70203	64.34210	11.2
112.1	117.99598	112.78018	107.58790	102.40446	97.15729	92.04046	87.06926	82.22442	77.53842	73.00924	11.1
112.2	117.99598	112.78018	107.58790	102.40446	97.15729	92.04046	87.06926	82.22442	77.53842	73.00924	11.2
112.3	120.94321	113.89349	108.62177	104.40723	100.79904	97.58319	94.64989	91.93512	89.38660	87.00476	11.1
112.4	120.94321	113.89349	108.62177	104.40723	100.79904	97.58319	94.64989	91.93512	89.38660	87.00476	11.2
112.5	127.25140	125.28365	123.68604	122.33152	121.13930	120.06384	119.07714	118.16077	117.30184	116.49101	11.1
112.6	127.25140	125.28365	123.68604	122.33152	121.13930	120.06384	119.07714	118.16077	117.30184	116.49101	11.2
112.7	127.60622	125.34436	123.69950	122.33491	121.14015	120.06406	119.07720	118.16078	117.30185	116.49101	11.1
112.8	127.60622	125.34436	123.69950	122.33491	121.14015	120.06406	119.07720	118.16078	117.30185	116.49101	11.2
120.0	132.60804	133.23304	133.87642	134.53983	135.22519	135.93472	136.67109	137.43744	138.23763	139.07639	12.1
120.1	132.60804	133.23304	133.87642	134.53983	135.22519	135.93472	136.67109	137.43744	138.23763	139.07639	12.1
120.2	87.77433	89.59994	91.48116	93.42300	95.43124	97.51266	99.67528	101.92873	104.28467	106.75754	12.0
120.3	87.77433	89.59994	91.48116	93.42300	95.43124	97.51266	99.67528	101.92873	104.28467	106.75754	12.0
120.4	46.84133	49.76974	52.79264	55.91853	59.15729	62.52052	66.02198	69.67821	73.50943	77.54983	12.0
120.5	46.84133	49.76974	52.79264	55.91853	59.15729	62.52052	66.02198	69.67821	73.50943	77.54983	12.0
120.6	9.80982	13.74373	17.81847	22.04046	26.42621	30.99284	35.76089	40.75549	46.00848	51.56206	12.0
120.7	9.80982	13.74373	17.81847	22.04046	26.42621	30.99284	35.76089	40.75549	46.00848	51.56206	12.0
120.8	23.31855	18.46658	13.42845	8.18721	-2.2237	2.98115	8.9857	15.30406	22.01179	29.20020	12.0
120.9	23.31855	18.46658	13.42845	8.18721	-2.2237	2.98115	8.9857	15.30406	22.01179	29.20020	12.0
121.0	52.54227	46.85724	40.92484	34.72181	28.22242	21.40126	14.23992	6.73820	-1.09462	9.18884	12.1
121.1	52.54227	46.85724	40.92484	34.72181	28.22242	21.40126	14.23992	6.73820	-1.09462	9.18884	12.1
121.2	77.85779	71.40626	64.61849	57.43904	49.73366	41.46701	32.32448	22.32803	11.34297	0.00000	12.0
121.3	77.85779	71.40626	64.61849	57.43904	49.73366	41.46701	32.32448	22.32803	11.34297	0.00000	12.0
121.4	99.24950	92.05900	84.32677	75.84376	66.37094	55.87896	44.69289	33.31136	22.22538	11.83982	12.1
121.5	99.24950	92.05900	84.32677	75.84376	66.37094	55.87896	44.69289	33.31136	22.22538	11.83982	12.1
121.6	116.65433	108.54615	99.19126	88.59639	77.32074	66.03323	55.43966	45.4204	36.21961	28.86916	12.1
121.7	116.65433	108.54615	99.19126	88.59639	77.32074	66.03323	55.43966	45.4204	36.21961	28.86916	12.1
121.8	116.70744	109.3602	100.83935	92.76304	84.59902	76.38842	68.00021	60.30021	52.90735	46.0662	12.1
121.9	116.70744	109.3602	100.83935	92.76304	84.59902	76.38842	68.00021	60.30021	52.90735	46.0662	12.1
122.0	130.31993	122.54720	115.16409	108.16409	102.42723	96.5870	91.22101	86.34443	81.80478	77.54983	12.1
122.1	130.31993	122.54720	115.16409	108.16409	102.42723	96.5870	91.22101	86.34443	81.80478	77.54983	12.1
122.2	138.07586	127.08806	117.31187	109.20383	102.42723	96.5870	91.22101	86.34443	81.80478	77.54983	12.1
122.3	138.07586	127.08806	117.31187	109.20383	102.42723	96.5870	91.22101	86.34443	81.80478	77.54983	12.1
122.4	143.49856	135.79253	129.97341	125.61179	121.75491	118.21567	115.08911	112.13226	109.36548	106.75754	12.1
122.5	143.49856	135.79253	129.97341	125.61179	121.75491	118.21567	115.08911	112.13226	109.36548	106.75754	12.1
122.6	150.87245	148.65947	146.91218	145.43616	144.13816	142.96738	141.89309	140.89519	139.95968	139.07639	12.1
122.7	150.87245	148.65947	146.91218	145.43616	144.13816	142.96738	141.89309	140.89519	139.95968	139.07639	12.1
122.8	151.11155	148.69573	146.91999	145.43760	144.13848	142.96745	141.89311	140.89521	139.95968	139.07639	12.1
122.9	151.11155	148.69573	146.91999	145.43760	144.13848	142.96745	141.89311	140.89521	139.95968	139.07639	12.1

## APPENDIX II

### LINE STRENGTHS

*(Reprinted with permission of P. C. Cross, R. M. Hainer and G. W. King, and the American Institute of Physics, from "The Journal of Chemical Physics, 12, 222-235 (1944))*

LINE strengths times  $10^4$ . First two columns on the left use top sign for  $\kappa$ ; last two columns on the right use bottom sign.  $(J, \tau | \lambda_g | J', \tau')$  is given by entries with P, Q, R for  $J' = J - 1$ , J,  $J + 1$  respectively:

$$(J, \tau | \lambda_g | J', \tau') = (J', \tau' | \lambda_g | J, \tau)$$

A, a and c prolate-and-oblate sub-branches.

Sub branch		A, a and c prolate-and-oblate sub-branches					Sub branch	
${}^{a,c}Q_{l,0}$	${}^{a,c}Q_{l,0}$	$\mp 1$	$\mp 0.5$	$0$	$\pm 0.5$	$\pm 1$	${}^{a,c}Q_{l,1}$	${}^{a,c}Q_{l,1}$
1 <sub>0,1</sub> ; -1	1 <sub>1,1,0</sub>	15000	15000	15000	15000	15000	1 <sub>1,0;1</sub>	1 <sub>1,1,0</sub>
2 <sub>0,2</sub> ; -2	2 <sub>1,2,-1</sub>	25000	28223	31100	32845	33333	2 <sub>2,0,2</sub>	2 <sub>2,1,1</sub>
3 <sub>0,3</sub> ; -3	3 <sub>1,3,-2</sub>	35000	45104	50431	52155	52500	3 <sub>3,0,3</sub>	3 <sub>3,1,2</sub>
4 <sub>0,4</sub> ; -4	4 <sub>1,4,-3</sub>	45000	64494	70244	71708	72000	4 <sub>4,0,4</sub>	4 <sub>4,1,3</sub>
5 <sub>0,5</sub> ; -5	5 <sub>1,5,-4</sub>	55000	84696	90073	91399	91667	5 <sub>5,0,5</sub>	5 <sub>5,1,4</sub>
6 <sub>0,6</sub> ; -6	6 <sub>1,6,-5</sub>	65000	104928	109923	111174	111429	6 <sub>6,0,6</sub>	6 <sub>6,1,5</sub>
7 <sub>0,7</sub> ; -7	7 <sub>1,7,-6</sub>	75000	125065	129799	131004	131250	7 <sub>7,0,7</sub>	7 <sub>7,1,6</sub>
8 <sub>0,8</sub> ; -8	8 <sub>1,8,-7</sub>	85000	145135	149698	150871	151111	8 <sub>8,0,8</sub>	8 <sub>8,1,7</sub>
9 <sub>0,9</sub> ; -9	9 <sub>1,9,-8</sub>	95000	165170	169614	170764	171000	9 <sub>9,0,9</sub>	9 <sub>9,1,8</sub>
10 <sub>0,10</sub> ; -10	10 <sub>1,10,-9</sub>	105000	185187	189544	190677	190909	10 <sub>10,0,10</sub>	10 <sub>10,1,9</sub>
11 <sub>0,11</sub> ; -11	11 <sub>1,11,-10</sub>	115000	205194	209484	210603	210834	11 <sub>11,0,11</sub>	11 <sub>11,1,10</sub>
12 <sub>0,12</sub> ; -12	12 <sub>1,12,-11</sub>	125000	225195	229434	230542	230769	12 <sub>12,0,12</sub>	12 <sub>12,1,11</sub>
2 <sub>1,1;0</sub>	2 <sub>2,1;1</sub>	8333	8333	8333	8333	8333	2 <sub>1,1,0</sub>	2 <sub>1,2;-1</sub>
3 <sub>1,2;-1</sub>	3 <sub>2,2,0</sub>	14583	16278	18811	21875	23333	3 <sub>2,1,1</sub>	3 <sub>2,2,0</sub>
4 <sub>1,3;-2</sub>	4 <sub>2,3;-1</sub>	20250	26168	34242	39363	40500	4 <sub>3,1,2</sub>	4 <sub>3,2,1</sub>
5 <sub>1,4;-3</sub>	5 <sub>2,4;-2</sub>	25667	39338	52949	57742	58667	5 <sub>4,1,3</sub>	5 <sub>4,2,2</sub>
6 <sub>1,5;-4</sub>	6 <sub>2,5;-3</sub>	30952	56179	72319	76548	77381	6 <sub>5,1,4</sub>	6 <sub>5,2,3</sub>
7 <sub>1,6;-5</sub>	7 <sub>2,6;-4</sub>	36161	75597	91744	95646	96429	7 <sub>6,1,5</sub>	7 <sub>6,2,4</sub>
8 <sub>1,7;-6</sub>	8 <sub>2,7;-5</sub>	41319	95950	111231	114943	115694	8 <sub>7,1,6</sub>	8 <sub>7,2,5</sub>
9 <sub>1,8;-7</sub>	9 <sub>2,8;-6</sub>	46444	116333	130792	134381	135111	9 <sub>8,1,7</sub>	9 <sub>8,2,6</sub>
10 <sub>1,9;-8</sub>	10 <sub>2,9;-7</sub>	51545	136551	150418	153921	154636	10 <sub>9,1,8</sub>	10 <sub>9,2,7</sub>
11 <sub>1,10;-9</sub>	11 <sub>2,10;-8</sub>	56629	156642	170100	173540	174242	11 <sub>10,1,9</sub>	11 <sub>10,2,8</sub>
12 <sub>1,11; 10</sub>	12 <sub>2,11;-9</sub>	61699	176660	189825	193216	193910	12 <sub>11,1,10</sub>	12 <sub>11,2,9</sub>
3 <sub>2,1;1</sub>	3 <sub>3,1;2</sub>	8750	7403	6406	5944	5833	3 <sub>1,2;-1</sub>	3 <sub>1,3;-2</sub>
4 <sub>2,2,0</sub>	4 <sub>3,2,1</sub>	15750	13221	13196	15598	18000	4 <sub>2,2,0</sub>	4 <sub>2,3;-1</sub>
5 <sub>2,3;-1</sub>	5 <sub>3,3,0</sub>	22000	19105	23397	30662	33000	5 <sub>3,2,1</sub>	5 <sub>3,3,0</sub>
6 <sub>2,4;-2</sub>	6 <sub>3,4;-1</sub>	27857	26374	38620	47709	49524	6 <sub>4,2,2</sub>	6 <sub>4,3,1</sub>
7 <sub>2,5;-3</sub>	7 <sub>3,5;-2</sub>	33482	36237	57062	65399	66964	7 <sub>5,2,3</sub>	7 <sub>5,3,2</sub>
8 <sub>2,6;-4</sub>	8 <sub>3,6;-3</sub>	38958	49682	76155	83565	85000	8 <sub>6,2,4</sub>	8 <sub>6,3,3</sub>
9 <sub>2,7;-5</sub>	9 <sub>3,7;-4</sub>	44333	66864	95251	102089	103444	9 <sub>7,2,5</sub>	9 <sub>7,3,4</sub>
10 <sub>2,8;-6</sub>	10 <sub>3,8;-5</sub>	49636	86630	114393	120880	122183	10 <sub>8,2,6</sub>	10 <sub>8,3,5</sub>
11 <sub>2,9;-7</sub>	11 <sub>3,9;-6</sub>	54886	107332	133621	139873	141136	11 <sub>9,2,7</sub>	11 <sub>9,3,6</sub>
12 <sub>2,10;-8</sub>	12 <sub>3,10;-7</sub>	60096	128002	152940	159022	160256	12 <sub>10,2,8</sub>	12 <sub>10,3,7</sub>
4 <sub>3,1;2</sub>	4 <sub>4,1,3</sub>	9000	7587	6026	4847	4500	4 <sub>1,3;-2</sub>	4 <sub>1,4;-3</sub>
5 <sub>3,2,1</sub>	5 <sub>4,2,2</sub>	16500	13464	11058	11750	14667	5 <sub>2,3;-1</sub>	5 <sub>2,4;-2</sub>
6 <sub>3,3,0</sub>	6 <sub>4,3,1</sub>	23214	18339	17488	23981	27857	6 <sub>3,3,0</sub>	6 <sub>3,4;-1</sub>
7 <sub>3,4;-1</sub>	7 <sub>4,4,0</sub>	29464	22914	27745	39794	42857	7 <sub>4,3,1</sub>	7 <sub>4,4,0</sub>
8 <sub>3,5;-2</sub>	8 <sub>4,5,-1</sub>	35417	28185	43063	56506	59028	8 <sub>5,3,2</sub>	8 <sub>5,4,1</sub>
9 <sub>3,6;-3</sub>	9 <sub>4,6,-2</sub>	41167	35293	61523	73754	76000	9 <sub>6,3,3</sub>	9 <sub>6,4,2</sub>
10 <sub>3,7;-4</sub>	10 <sub>4,7;-3</sub>	46773	45350	80547	91464	93546	10 <sub>7,3,4</sub>	10 <sub>7,4,3</sub>
11 <sub>3,8;-5</sub>	11 <sub>4,8;-4</sub>	52273	59213	99473	109542	111515	11 <sub>8,3,5</sub>	11 <sub>8,4,4</sub>
12 <sub>3,9;-6</sub>	12 <sub>4,9;-5</sub>	57692	76888	118383	127913	129808	12 <sub>9,3,6</sub>	12 <sub>9,4,5</sub>
5 <sub>4,1,3</sub>	5 <sub>5,1,4</sub>	9167	7777	6127	4374	3667	5 <sub>1,4;-3</sub>	5 <sub>1,5;-4</sub>
6 <sub>4,2,2</sub>	6 <sub>5,2,3</sub>	17024	14084	10758	9464	12381	6 <sub>2,4;-2</sub>	6 <sub>2,5;-3</sub>
7 <sub>4,3,1</sub>	7 <sub>5,3,2</sub>	24107	19340	15156	18769	24107	7 <sub>3,4;-1</sub>	7 <sub>3,5;-2</sub>
8 <sub>4,4,0</sub>	8 <sub>5,4,1</sub>	30694	23768	21441	33034	37778	8 <sub>4,4,0</sub>	8 <sub>4,5;-1</sub>
9 <sub>4,5,-1</sub>	9 <sub>5,5,0</sub>	36944	27638	31860	49002	52778	9 <sub>5,4,1</sub>	9 <sub>5,5,0</sub>
10 <sub>4,6;-2</sub>	10 <sub>5,6,-1</sub>	42955	31542	47402	65474	68727	10 <sub>6,4,2</sub>	10 <sub>6,5,1</sub>
11 <sub>4,7;-3</sub>	11 <sub>5,7;-2</sub>	48788	36457	66028	82425	85379	11 <sub>7,4,3</sub>	11 <sub>7,5,2</sub>
12 <sub>4,8;-4</sub>	12 <sub>5,8,-3</sub>	54487	43527	85120	99805	102564	12 <sub>8,4,4</sub>	12 <sub>8,5,3</sub>
6 <sub>5,1,4</sub>	6 <sub>6,1,5</sub>	9286	7913	6271	4244	3095	6 <sub>1,5;-4</sub>	6 <sub>1,6;-5</sub>
7 <sub>5,2,3</sub>	7 <sub>6,2,4</sub>	17411	14552	11116	8220	10714	7 <sub>2,5;-3</sub>	7 <sub>2,6;-4</sub>
8 <sub>5,3,2</sub>	8 <sub>6,3,3</sub>	24792	20246	14956	14996	21250	8 <sub>3,5;-2</sub>	8 <sub>3,6;-3</sub>
9 <sub>5,4,1</sub>	9 <sub>6,4,2</sub>	31667	25157	18940	27035	33778	9 <sub>4,5,-1</sub>	9 <sub>4,6;-2</sub>
10 <sub>5,5,0</sub>	10 <sub>6,5,1</sub>	38182	29364	25162	42308	47727	10 <sub>5,5,0</sub>	10 <sub>5,6;-1</sub>
11 <sub>5,6;-1</sub>	11 <sub>6,6,0</sub>	44432	32945	35783	58220	62727	11 <sub>6,5,1</sub>	11 <sub>6,6,0</sub>
12 <sub>5,7;-2</sub>	12 <sub>6,7,-1</sub>	50481	36135	51610	74526	78526	12 <sub>7,5,2</sub>	12 <sub>7,6,1</sub>

Sub-branch		K					Sub-branch	
$^{\infty}Q_{1,0}$	$^{\infty}Q_{1,0}$	$\mp 1$	$\mp 0.5$	0	$\pm 0.5$	$\pm 1$	$^{\infty}Q_{0,1}$	$^{\infty}Q_{0,1}$
7 <sub>6,1,5</sub>	7 <sub>7,1,6</sub>	9375	8011	6383	4273	2679	7 <sub>1,6;-5</sub>	7 <sub>1,7;-6</sub>
8 <sub>6,2,4</sub>	8 <sub>7,2,5</sub>	17708	14899	11514	7682	9444	8 <sub>2,6;-4</sub>	8 <sub>2,7;-5</sub>
9 <sub>6,3,3</sub>	9 <sub>7,3,4</sub>	25333	20931	15562	12549	19000	9 <sub>3,6;-3</sub>	9 <sub>3,7;-4</sub>
10 <sub>6,4,2</sub>	10 <sub>7,4,3</sub>	32455	26254	18837	21925	30545	10 <sub>4,6;-2</sub>	10 <sub>4,7;-3</sub>
11 <sub>6,5,1</sub>	11 <sub>7,5,2</sub>	39205	30943	22510	36052	43561	11 <sub>5,6;-1</sub>	11 <sub>5,7;-2</sub>
12 <sub>6,6,0</sub>	12 <sub>7,6,1</sub>	45673	35027	28709	51607	57692	12 <sub>6,6,0</sub>	12 <sub>6,7,1</sub>
8 <sub>7,1,6</sub>	8 <sub>8,1,7</sub>	9444	8087	6468	4346	2361	8 <sub>1,7;-6</sub>	8 <sub>1,8;-7</sub>
9 <sub>7,2,5</sub>	9 <sub>8,2,6</sub>	17944	15167	11832	7594	8444	9 <sub>2,7;-5</sub>	9 <sub>2,8;-6</sub>
10 <sub>7,3,4</sub>	10 <sub>8,3,5</sub>	25773	21462	16215	11172	17182	10 <sub>3,7;-4</sub>	10 <sub>3,8;-5</sub>
11 <sub>7,4,3</sub>	11 <sub>8,4,4</sub>	33106	27105	19675	18011	27879	11 <sub>4,7;-3</sub>	11 <sub>4,8;-4</sub>
12 <sub>7,5,2</sub>	12 <sub>8,5,3</sub>	40064	32174	22501	30163	40064	12 <sub>5,7;-2</sub>	12 <sub>5,8,3</sub>
9 <sub>8,1,7</sub>	9 <sub>9,1,8</sub>	9500	8146	6535	4418	2111	9 <sub>1,8;-7</sub>	9 <sub>1,9;-8</sub>
10 <sub>8,2,6</sub>	10 <sub>9,2,7</sub>	18136	15380	12081	7731	7636	10 <sub>2,8;-6</sub>	10 <sub>2,9,-7</sub>
11 <sub>8,3,5</sub>	11 <sub>9,3,6</sub>	26136	21887	16748	10598	15682	11 <sub>3,8;-5</sub>	11 <sub>3,9,-6</sub>
12 <sub>8,4,4</sub>	12 <sub>9,4,5</sub>	33654	27788	20570	15383	25641	12 <sub>4,8;-4</sub>	12 <sub>4,9,-5</sub>
10 <sub>9,1,8</sub>	10 <sub>10,1,9</sub>	9545	8194	6588	4479	1909	10 <sub>1,9;-8</sub>	10 <sub>1,10,-9</sub>
11 <sub>9,2,7</sub>	11 <sub>10,2,8</sub>	18295	15554	12280	7933	6970	11 <sub>2,9,-7</sub>	11 <sub>2,10,-8</sub>
12 <sub>9,3,6</sub>	12 <sub>10,3,7</sub>	26442	22237	17176	10563	14423	12 <sub>3,9;-6</sub>	12 <sub>3,10,-7</sub>
11 <sub>10,1,9</sub>	11 <sub>11,1,10</sub>	9583	8234	6631	4530	1742	11 <sub>1,10,-9</sub>	11 <sub>1,11,-10</sub>
12 <sub>10,2,8</sub>	12 <sub>11,2,9</sub>	18429	15699	12443	8126	6410	12 <sub>2,10,-8</sub>	12 <sub>2,11,-9</sub>
12 <sub>11,1,10</sub>	12 <sub>12,1,11</sub>	9615	8268	6667	4571	1603	12 <sub>1,11,-10</sub>	12 <sub>1,12,-11</sub>
$^{\infty}R_{1,0}$	$^{\infty}P_{1,0}$	$\mp 1$	$\mp 0.5$	0	$\pm 0.5$	$\pm 1$	$^{\infty}R_{0,1}$	$^{\infty}P_{0,1}$
0 <sub>0,0,0</sub>	1 <sub>1,0,1</sub>	10000	10000	10000	10000	10000	0 <sub>0,0,0</sub>	1 <sub>0,1,-1</sub>
1 <sub>1,0,1</sub>	2 <sub>2,0,2</sub>	15000	16934	18660	19707	20000	1 <sub>0,1,-1</sub>	2 <sub>0,2,-2</sub>
2 <sub>2,0,2</sub>	3 <sub>3,0,3</sub>	25000	25893	27201	29029	30000	2 <sub>0,2,2</sub>	3 <sub>0,3,-3</sub>
3 <sub>3,0,3</sub>	4 <sub>4,0,4</sub>	35000	35773	36728	38312	40000	3 <sub>0,3,-3</sub>	4 <sub>0,4,-4</sub>
4 <sub>4,0,4</sub>	5 <sub>5,0,5</sub>	45000	45745	46619	47897	50000	4 <sub>0,4,-4</sub>	5 <sub>0,5,-5</sub>
5 <sub>5,0,5</sub>	6 <sub>6,0,6</sub>	55000	55730	56582	57727	60000	5 <sub>0,5,-5</sub>	6 <sub>0,6,-6</sub>
6 <sub>6,0,6</sub>	7 <sub>7,0,7</sub>	65000	65721	66562	67660	70000	6 <sub>0,6,-6</sub>	7 <sub>0,7,-7</sub>
7 <sub>7,0,7</sub>	8 <sub>8,0,8</sub>	75000	75714	76549	77628	80000	7 <sub>0,7,-7</sub>	8 <sub>0,8,-8</sub>
8 <sub>8,0,8</sub>	9 <sub>9,0,9</sub>	85000	85708	86539	87610	90000	8 <sub>0,8,-8</sub>	9 <sub>0,9,-9</sub>
9 <sub>9,0,9</sub>	10 <sub>10,0,10</sub>	95000	95704	96531	97597	100000	9 <sub>0,9,-9</sub>	10 <sub>0,10,-10</sub>
10 <sub>10,0,10</sub>	11 <sub>11,0,11</sub>	105000	105701	106525	107588	110000	10 <sub>0,10,-10</sub>	11 <sub>0,11,-11</sub>
11 <sub>11,0,11</sub>	12 <sub>12,0,12</sub>	115000	115698	116519	117580	120000	11 <sub>0,11,-11</sub>	12 <sub>0,12,-12</sub>
1 <sub>0,1,-1</sub>	2 <sub>1,1,0</sub>	15000	15000	15000	15000	15000	1 <sub>1,0,1</sub>	2 <sub>1,1,0</sub>
2 <sub>1,1,0</sub>	3 <sub>2,1,1</sub>	16667	22500	25581	26509	26667	2 <sub>1,1,0</sub>	3 <sub>1,2,-1</sub>
3 <sub>2,1,1</sub>	4 <sub>3,1,2</sub>	26250	29261	33801	36902	37500	3 <sub>1,2,-1</sub>	4 <sub>1,3,-2</sub>
4 <sub>3,1,2</sub>	5 <sub>4,1,3</sub>	36000	38400	41758	46530	48000	4 <sub>1,3,-2</sub>	5 <sub>1,4,-3</sub>
5 <sub>4,1,3</sub>	6 <sub>5,1,4</sub>	45833	48106	50867	55601	58333	5 <sub>1,4,-3</sub>	6 <sub>1,5,-4</sub>
6 <sub>5,1,4</sub>	7 <sub>6,1,5</sub>	55714	57930	60533	64605	68571	6 <sub>1,5,-4</sub>	7 <sub>1,6,-5</sub>
7 <sub>6,1,5</sub>	8 <sub>7,1,6</sub>	65625	67805	70356	73938	78750	7 <sub>1,6,-5</sub>	8 <sub>1,7,-6</sub>
8 <sub>7,1,6</sub>	9 <sub>8,1,7</sub>	75556	77710	80235	83593	88889	8 <sub>1,7,-6</sub>	9 <sub>1,8,-7</sub>
9 <sub>8,1,7</sub>	10 <sub>9,1,8</sub>	85500	87636	90142	93412	99000	9 <sub>1,8,-7</sub>	10 <sub>1,9,-8</sub>
10 <sub>9,1,8</sub>	11 <sub>10,1,9</sub>	95455	97576	100068	103301	109091	10 <sub>1,9,-8</sub>	11 <sub>1,10,-9</sub>
11 <sub>10,1,9</sub>	12 <sub>11,1,10</sub>	105416	107526	110008	113219	119166	11 <sub>1,10,-9</sub>	12 <sub>1,11,-10</sub>
2 <sub>0,2,-2</sub>	3 <sub>1,2,-1</sub>	20000	18636	17345	16724	16667	2 <sub>2,0,2</sub>	3 <sub>2,1,1</sub>
3 <sub>1,2,-1</sub>	4 <sub>2,2,0</sub>	18750	29055	30992	30230	30000	3 <sub>2,1,1</sub>	4 <sub>2,2,0</sub>
4 <sub>2,2,0</sub>	5 <sub>3,2,1</sub>	28000	34387	41441	42462	42000	4 <sub>2,2,0</sub>	5 <sub>2,3,-1</sub>
5 <sub>3,2,1</sub>	6 <sub>4,2,2</sub>	37500	41961	49227	53738	53333	5 <sub>2,3,-1</sub>	6 <sub>2,4,-2</sub>
6 <sub>4,2,2</sub>	7 <sub>5,2,3</sub>	47143	51182	56697	64087	64286	6 <sub>2,4,-2</sub>	7 <sub>2,5,-3</sub>
7 <sub>5,2,3</sub>	8 <sub>6,2,4</sub>	56875	60756	65450	73564	75000	7 <sub>2,5,-3</sub>	8 <sub>2,6,-4</sub>
8 <sub>6,2,4</sub>	9 <sub>7,2,5</sub>	66667	70451	74899	82413	85556	8 <sub>2,6,-4</sub>	9 <sub>2,7,-5</sub>
9 <sub>7,2,5</sub>	10 <sub>8,2,6</sub>	76500	80218	84567	91174	96000	9 <sub>2,7,-5</sub>	10 <sub>2,8,-6</sub>
10 <sub>8,2,6</sub>	11 <sub>9,2,7</sub>	86364	90031	94328	100297	106364	10 <sub>2,8,-6</sub>	11 <sub>2,9,-7</sub>
11 <sub>9,2,7</sub>	12 <sub>10,2,8</sub>	96250	99880	104134	109796	116666	11 <sub>2,9,-7</sub>	12 <sub>2,10,-8</sub>

Sub-branch							Sub-branch	
$\kappa R_{1,0}$	$\kappa P_{1,0}$	$\mp 1$	$\mp 0.5$	$\kappa 0$	$\pm 0.5$	$\pm 1$	$\kappa R_{0,1}$	$\kappa P_{0,1}$
3 <sub>0,3</sub> ;-3	4 <sub>1,3</sub> ;-2	25000	20331	18001	17567	17500	3 <sub>3,0,3</sub>	4 <sub>3,1</sub> ;2
4 <sub>1,3</sub> ;-2	5 <sub>2,3</sub> ;-1	21000	34848	33475	32109	32000	4 <sub>3,1,2</sub>	5 <sub>3,2</sub> ;1
5 <sub>2,3</sub> ;-1	6 <sub>3,3</sub> ;0	30000	41218	47032	45219	45000	5 <sub>3,2,1</sub>	6 <sub>3,3</sub> ;0
6 <sub>3,3</sub> ;0	7 <sub>4,3</sub> ;1	39286	46575	57381	57683	57143	6 <sub>3,3,0</sub>	7 <sub>3,4</sub> ;-1
7 <sub>4,3</sub> ;1	8 <sub>5,3</sub> ;2	48750	54876	64788	69691	68750	7 <sub>3,4,-1</sub>	8 <sub>3,5</sub> ;-2
8 <sub>5,3</sub> ;2	9 <sub>6,3</sub> ;3	58333	64092	71834	80981	80000	8 <sub>3,5,-2</sub>	9 <sub>3,6</sub> ;-3
9 <sub>6,3</sub> ;3	10 <sub>7,3</sub> ;4	68000	73557	80274	91312	91000	9 <sub>3,6,-3</sub>	10 <sub>3,7</sub> ;-4
10 <sub>7,3</sub> ;4	11 <sub>8,3</sub> ;5	77727	83447	89526	100665	101818	10 <sub>3,7,-4</sub>	11 <sub>3,8</sub> ;-5
11 <sub>8,3</sub> ;5	12 <sub>9,3</sub> ;6	87500	92819	90948	109320	112500	11 <sub>3,8,-5</sub>	12 <sub>3,9</sub> ;-6
4 <sub>0,4</sub> ;-4	5 <sub>1,4</sub> ;-3	30000	20650	18478	18082	18000	4 <sub>4,0,4</sub>	5 <sub>4,1</sub> ;3
5 <sub>1,4</sub> ;-3	6 <sub>2,4</sub> ;-2	23333	38686	34370	33475	33333	5 <sub>4,1,3</sub>	6 <sub>4,2</sub> ;2
6 <sub>2,4</sub> ;-2	7 <sub>3,4</sub> ;-1	32143	48639	49439	47326	47143	6 <sub>4,2,2</sub>	7 <sub>4,3</sub> ;1
7 <sub>3,4</sub> ;-1	8 <sub>4,4</sub> ;0	41250	52676	63082	60238	60000	7 <sub>4,3,1</sub>	8 <sub>4,4</sub> ;0
8 <sub>4,4</sub> ;0	9 <sub>5,4</sub> ;1	50556	59229	73357	72645	72222	8 <sub>4,4,0</sub>	9 <sub>4,5</sub> ;-1
9 <sub>5,4</sub> ;1	10 <sub>6,4</sub> ;2	60000	67888	80428	84877	84000	9 <sub>4,5,-1</sub>	10 <sub>4,6</sub> ;-2
10 <sub>6,4</sub> ;2	11 <sub>7,4</sub> ;3	69546	77064	87093	96881	95455	10 <sub>4,6,-2</sub>	11 <sub>4,7</sub> ;-3
11 <sub>7,4</sub> ;3	12 <sub>8,4</sub> ;4	79167	86444	95254	108226	106666	11 <sub>4,7,-3</sub>	12 <sub>4,8</sub> ;-4
5 <sub>0,5</sub> ;-5	6 <sub>1,5</sub> ;-4	35000	20660	18847	18422	18333	5 <sub>5,0,5</sub>	6 <sub>5,1</sub> ;4
6 <sub>1,5</sub> ;-4	7 <sub>2,5</sub> ;-3	25714	40254	35224	34447	34286	6 <sub>5,1,4</sub>	7 <sub>5,2</sub> ;3
7 <sub>2,5</sub> ;-3	8 <sub>3,5</sub> ;-2	34375	54914	50352	48971	48750	7 <sub>5,2,3</sub>	8 <sub>5,3</sub> ;2
8 <sub>3,5</sub> ;-2	9 <sub>4,5</sub> ;-1	43333	60334	65354	62490	62222	8 <sub>5,3,2</sub>	9 <sub>5,4</sub> ;1
9 <sub>4,5</sub> ;-1	10 <sub>5,5</sub> ;0	52500	64543	79136	75309	75000	9 <sub>5,4,1</sub>	10 <sub>5,5</sub> ;0
10 <sub>5,5</sub> ;0	11 <sub>6,5</sub> ;1	61818	72156	89354	87664	87273	10 <sub>5,5,0</sub>	11 <sub>5,6</sub> ;-1
11 <sub>6,5</sub> ;1	12 <sub>7,5</sub> ;2	71250	80944	96120	99820	99167	11 <sub>5,6,-1</sub>	12 <sub>5,7</sub> ;-2
6 <sub>0,6</sub> ;-6	7 <sub>1,6</sub> ;-5	40000	20793	19108	18664	18571	6 <sub>6,0,6</sub>	7 <sub>6,1</sub> ;5
7 <sub>1,6</sub> ;-5	8 <sub>2,6</sub> ;-4	28125	40367	35988	35171	35000	7 <sub>6,1,5</sub>	8 <sub>6,2</sub> ;4
8 <sub>2,6</sub> ;-4	9 <sub>3,6</sub> ;-3	36667	58807	51410	50241	50000	8 <sub>6,2,4</sub>	9 <sub>6,3</sub> ;3
9 <sub>3,6</sub> ;-3	10 <sub>4,6</sub> ;-2	45500	68406	66193	64301	64000	9 <sub>6,3,3</sub>	10 <sub>6,4</sub> ;2
10 <sub>4,6</sub> ;-2	11 <sub>5,6</sub> ;-1	54546	71334	81252	77627	77273	10 <sub>6,4,2</sub>	11 <sub>6,5</sub> ;1
11 <sub>5,6</sub> ;-1	12 <sub>6,6</sub> ;0	63750	77023	95192	90399	90000	11 <sub>6,5,1</sub>	12 <sub>6,6</sub> ;0
7 <sub>0,7</sub> ;-7	8 <sub>1,7</sub> ;-6	45000	20990	19300	18844	18750	7 <sub>7,0,7</sub>	8 <sub>7,1</sub> ;6
8 <sub>1,7</sub> ;-6	9 <sub>2,7</sub> ;-5	30556	40255	36587	35733	35556	8 <sub>7,1,6</sub>	9 <sub>7,2</sub> ;5
9 <sub>2,7</sub> ;-5	10 <sub>3,7</sub> ;-4	39000	60147	52457	51252	51000	9 <sub>7,2,5</sub>	10 <sub>7,3</sub> ;4
10 <sub>3,7</sub> ;-4	11 <sub>4,7</sub> ;-3	47727	75043	67350	65775	65455	10 <sub>7,3,4</sub>	11 <sub>7,4</sub> ;3
11 <sub>4,7</sub> ;-3	12 <sub>5,7</sub> ;-2	56667	79651	81971	79549	79167	11 <sub>7,4,3</sub>	12 <sub>7,5</sub> ;2
8 <sub>0,8</sub> ;-8	9 <sub>1,8</sub> ;-7	50000	21170	19449	18985	18889	8 <sub>8,0,8</sub>	9 <sub>8,1</sub> ;7
9 <sub>1,8</sub> ;-7	10 <sub>2,8</sub> ;-6	33000	40430	37059	36182	36000	9 <sub>8,1,7</sub>	10 <sub>8,2</sub> ;6
10 <sub>2,8</sub> ;-6	11 <sub>3,8</sub> ;-5	41364	59963	53330	52078	51818	10 <sub>8,2,6</sub>	11 <sub>8,3</sub> ;5
11 <sub>3,8</sub> ;-5	12 <sub>4,8</sub> ;-4	50000	78946	68596	66999	66667	11 <sub>8,3,5</sub>	12 <sub>8,4</sub> ;4
9 <sub>0,9</sub> ;-9	10 <sub>1,9</sub> ;-8	55000	21315	19566	19097	19000	9 <sub>9,0,9</sub>	10 <sub>9,1</sub> ;8
10 <sub>1,9</sub> ;-8	11 <sub>2,9</sub> ;-7	35454	40779	37443	36548	36364	10 <sub>9,1,8</sub>	11 <sub>9,2</sub> ;7
11 <sub>2,9</sub> ;-7	12 <sub>3,9</sub> ;-6	43750	59640	54051	52766	52500	11 <sub>9,2,7</sub>	12 <sub>9,3</sub> ;6
10 <sub>0,10</sub> ;-10	11 <sub>1,10</sub> ;-9	60000	21432	19662	19189	19091	10 <sub>10,0,10</sub>	11 <sub>10,1</sub> ;9
11 <sub>1,10</sub> ;-9	12 <sub>2,10</sub> ;-8	37917	41138	37761	36854	36667	11 <sub>10,1,9</sub>	12 <sub>10,2</sub> ;8
11 <sub>0,11</sub> ;-11	12 <sub>1,11</sub> ;-10	65000	21527	19742	19265	19167	11 <sub>11,0</sub> ;11	12 <sub>11,1</sub> ;10
$\kappa R_{1,0}$	$\kappa P_{1,0}$	$\mp 1$	$\mp 0.5$	0	$\pm 0.5$	$\pm 1$	$\kappa R_{0,1}$	$\kappa P_{0,1}$
1 <sub>1,1,0</sub>	2 <sub>2,1,1</sub>	15000	15000	15000	15000	15000	1 <sub>1,1,0</sub>	2 <sub>1,2</sub> ;-1
2 <sub>2,1,1</sub>	3 <sub>3,1,2</sub>	25000	25710	26243	26564	26667	2 <sub>1,2,-1</sub>	3 <sub>1,3</sub> ;-2
3 <sub>3,1,2</sub>	4 <sub>4,1,3</sub>	35000	35758	36540	37210	37500	3 <sub>1,3,-2</sub>	4 <sub>1,4</sub> ;-3
4 <sub>4,1,3</sub>	5 <sub>5,1,4</sub>	45000	45743	46583	47478	48000	4 <sub>1,4,-3</sub>	5 <sub>1,5</sub> ;-4
5 <sub>5,1,4</sub>	6 <sub>6,1,5</sub>	55000	55730	56576	57578	58333	5 <sub>1,5,-4</sub>	6 <sub>1,6</sub> ;-5
6 <sub>6,1,5</sub>	7 <sub>7,1,6</sub>	65000	65721	66561	67607	68571	6 <sub>1,6,-5</sub>	7 <sub>1,7</sub> ;-6
7 <sub>7,1,6</sub>	8 <sub>8,1,7</sub>	75000	75714	76550	77609	78750	7 <sub>1,7,-6</sub>	8 <sub>1,8</sub> ;-7
8 <sub>8,1,7</sub>	9 <sub>9,1,8</sub>	85000	85708	86539	87603	88889	8 <sub>1,8,-7</sub>	9 <sub>1,9</sub> ;-8
9 <sub>9,1,8</sub>	10 <sub>10,1,9</sub>	95000	95704	96531	97595	99000	9 <sub>1,9,-8</sub>	10 <sub>1,10</sub> ;-9
10 <sub>10,1,9</sub>	11 <sub>11,1,10</sub>	105000	105701	106525	107587	109091	10 <sub>1,10,-9</sub>	11 <sub>1,11</sub> ;-10
11 <sub>11,1,10</sub>	12 <sub>12,1,11</sub>	115000	115698	116519	117580	119166	11 <sub>1,11,-10</sub>	12 <sub>1,12</sub> ;-11

Sub-branch							Sub-branch	
$^{\infty}R_{1,0}$	$^{\infty}P_{1,0}$	$\mp 1$	$\mp 0.5$	$\kappa$ 0	$\pm 0.5$	$\pm 1$	$^{\infty}R_{0,1}$	$^{\infty}P_{0,1}$
2 <sub>1,2;-1</sub>	3 <sub>2,2,0</sub>	16667	16667	16667	16667	16667	2 <sub>2,1;1</sub>	3 <sub>2,2;0</sub>
3 <sub>2,2,0</sub>	4 <sub>3,2,1</sub>	26250	28258	29391	29882	30000	3 <sub>2,2,0</sub>	4 <sub>2,3;-1</sub>
4 <sub>3,2,1</sub>	5 <sub>4,2,2</sub>	36000	38290	40354	41637	42000	4 <sub>2,3;-1</sub>	5 <sub>2,4;-2</sub>
5 <sub>4,2,2</sub>	6 <sub>5,2,3</sub>	45833	48091	50537	52600	53333	5 <sub>2,4;-2</sub>	6 <sub>2,5;-3</sub>
6 <sub>5,2,3</sub>	7 <sub>6,2,4</sub>	55714	57929	60461	63088	64286	6 <sub>2,5;-3</sub>	7 <sub>2,6;-4</sub>
7 <sub>6,2,4</sub>	8 <sub>7,2,5</sub>	65625	67805	70340	73291	75000	7 <sub>2,6;-4</sub>	8 <sub>2,7;-5</sub>
8 <sub>7,2,5</sub>	9 <sub>8,2,6</sub>	75556	77710	80231	83338	85556	8 <sub>2,7;-5</sub>	9 <sub>2,8;-6</sub>
9 <sub>8,2,6</sub>	10 <sub>9,2,7</sub>	85500	87636	90142	93314	96000	9 <sub>2,8;-6</sub>	10 <sub>2,9;-7</sub>
10 <sub>9,2,7</sub>	11 <sub>10,2,8</sub>	95455	97576	100068	103262	106364	10 <sub>2,9;-7</sub>	11 <sub>2,10;-8</sub>
11 <sub>10,2,8</sub>	12 <sub>11,2,9</sub>	105416	107526	110008	113205	116666	11 <sub>2,10;-8</sub>	12 <sub>2,11;-9</sub>
3 <sub>1,3;-2</sub>	4 <sub>2,3;-1</sub>	18750	18207	17796	17564	17500	3 <sub>3,1;2</sub>	4 <sub>3,2,1</sub>
4 <sub>2,3;-1</sub>	5 <sub>3,3;0</sub>	28000	31148	32063	32074	32000	4 <sub>3,2,1</sub>	5 <sub>3,3;0</sub>
5 <sub>3,3;0</sub>	6 <sub>4,3,1</sub>	37500	41486	44187	45001	45000	5 <sub>3,3;0</sub>	6 <sub>3,4;-1</sub>
6 <sub>4,3,1</sub>	7 <sub>5,3,2</sub>	47143	51127	54949	56948	57143	6 <sub>3,4;-1</sub>	7 <sub>3,5;-2</sub>
7 <sub>5,3,2</sub>	8 <sub>6,3,3</sub>	56875	60749	64999	68208	68750	7 <sub>3,5;-2</sub>	8 <sub>3,6;-3</sub>
8 <sub>6,3,3</sub>	9 <sub>7,3,4</sub>	66667	70450	74791	78959	80000	8 <sub>3,6;-3</sub>	9 <sub>3,7;-4</sub>
9 <sub>7,3,4</sub>	10 <sub>8,3,5</sub>	76500	80217	84543	89339	91000	9 <sub>3,7;-4</sub>	10 <sub>3,8;-5</sub>
10 <sub>8,3,5</sub>	11 <sub>9,3,6</sub>	86364	90031	94320	99469	101818	10 <sub>3,8;-5</sub>	11 <sub>3,9;-6</sub>
11 <sub>9,3,6</sub>	12 <sub>10,3,7</sub>	96250	99880	104133	109453	112500	11 <sub>3,9;-6</sub>	12 <sub>3,10;-7</sub>
4 <sub>1,4;-3</sub>	5 <sub>2,4;-2</sub>	21000	19363	18449	18082	18000	4 <sub>4,1;3</sub>	5 <sub>4,2;2</sub>
5 <sub>2,4;-2</sub>	6 <sub>3,4;-1</sub>	30000	33887	33934	33473	33333	5 <sub>4,2;2</sub>	6 <sub>4,3,1</sub>
6 <sub>3,4;-1</sub>	7 <sub>4,4,0</sub>	39286	45000	47370	47311	47143	6 <sub>4,3,1</sub>	7 <sub>4,4,0</sub>
7 <sub>4,4,0</sub>	8 <sub>5,4,1</sub>	48750	54655	59178	60145	60000	7 <sub>4,4,0</sub>	8 <sub>4,5;-1</sub>
8 <sub>5,4,1</sub>	9 <sub>6,4,2</sub>	58333	64063	69788	72255	72222	8 <sub>4,5;-1</sub>	9 <sub>4,6;-2</sub>
9 <sub>6,4,2</sub>	10 <sub>7,4,3</sub>	68000	73554	79716	83787	84000	9 <sub>4,6;-2</sub>	10 <sub>4,7;-3</sub>
10 <sub>7,4,3</sub>	11 <sub>8,4,4</sub>	77727	83147	89384	94830	95455	10 <sub>4,7;-3</sub>	11 <sub>4,8;-4</sub>
11 <sub>8,4,4</sub>	12 <sub>9,4,5</sub>	87500	92819	99012	105459	106666	11 <sub>4,8;-4</sub>	12 <sub>4,9;-5</sub>
5 <sub>1,5;-4</sub>	6 <sub>2,5;-3</sub>	23333	20137	18843	18422	18333	5 <sub>5,1;4</sub>	6 <sub>5,2;3</sub>
6 <sub>2,5;-3</sub>	7 <sub>3,5;-2</sub>	32143	36189	35151	34447	34286	6 <sub>5,2;3</sub>	7 <sub>5,3;2</sub>
7 <sub>3,5;-2</sub>	8 <sub>4,5;-1</sub>	41250	48511	49684	48970	48750	7 <sub>5,3;2</sub>	8 <sub>5,4;1</sub>
8 <sub>4,5;-1</sub>	9 <sub>5,5;0</sub>	50556	58512	62686	62483	62222	8 <sub>5,4;1</sub>	9 <sub>5,5;0</sub>
9 <sub>5,5;0</sub>	10 <sub>6,5,1</sub>	60000	67785	74286	75273	75000	9 <sub>5,5;0</sub>	10 <sub>5,6;-1</sub>
10 <sub>6,5,1</sub>	11 <sub>7,5,2</sub>	69546	77050	84774	87504	87273	10 <sub>5,6;-1</sub>	11 <sub>5,7;-2</sub>
11 <sub>7,5,2</sub>	12 <sub>8,5,3</sub>	79167	86442	94594	99259	99167	11 <sub>5,7;-2</sub>	12 <sub>5,8;-3</sub>
6 <sub>1,6;-5</sub>	7 <sub>2,6;-4</sub>	25714	20629	19107	18664	18571	6 <sub>6,1;5</sub>	7 <sub>6,2,4</sub>
7 <sub>2,6;-4</sub>	8 <sub>3,6;-3</sub>	34375	37948	35978	35171	35000	7 <sub>6,2,4</sub>	8 <sub>6,3;3</sub>
8 <sub>3,6;-3</sub>	9 <sub>4,6;-2</sub>	43333	51721	51284	50241	50000	8 <sub>6,3;3</sub>	9 <sub>6,4,2</sub>
9 <sub>4,6;-2</sub>	10 <sub>5,6;-1</sub>	52500	62496	65297	64301	64000	9 <sub>6,4,2</sub>	10 <sub>6,5,1</sub>
10 <sub>5,6;-1</sub>	11 <sub>6,6,0</sub>	61818	71831	78026	77624	77273	10 <sub>6,5,1</sub>	11 <sub>6,6,0</sub>
11 <sub>6,6,0</sub>	12 <sub>7,6;1</sub>	71250	80896	89476	90385	90000	11 <sub>6,6,0</sub>	12 <sub>6,7;-1</sub>
7 <sub>1,7;-6</sub>	8 <sub>2,7;-5</sub>	28125	20944	19300	18844	18750	7 <sub>7,1;6</sub>	8 <sub>7,2,5</sub>
8 <sub>2,7;-5</sub>	9 <sub>3,7;-4</sub>	36667	39200	36585	35733	35556	8 <sub>7,2,5</sub>	9 <sub>7,3,4</sub>
9 <sub>3,7;-4</sub>	10 <sub>4,7;-3</sub>	45500	54420	52436	51252	51000	9 <sub>7,3,4</sub>	10 <sub>7,4,3</sub>
10 <sub>4,7;-3</sub>	11 <sub>5,7;-2</sub>	54546	66365	67167	65775	65455	10 <sub>7,4,3</sub>	11 <sub>7,5,2</sub>
11 <sub>5,7;-2</sub>	12 <sub>6,7;-1</sub>	63750	76087	80851	79549	79167	11 <sub>7,5,2</sub>	12 <sub>7,6;1</sub>
8 <sub>1,8;-7</sub>	9 <sub>2,8;-6</sub>	30556	21157	19449	18985	18889	8 <sub>8,1,7</sub>	9 <sub>8,2,6</sub>
9 <sub>2,8;-6</sub>	10 <sub>3,8;-5</sub>	39000	40063	37061	36182	36000	9 <sub>8,2,6</sub>	10 <sub>8,3,5</sub>
10 <sub>3,8;-5</sub>	11 <sub>4,8;-4</sub>	47727	56523	53327	52078	51818	10 <sub>8,3,5</sub>	11 <sub>8,4,4</sub>
11 <sub>4,8;-4</sub>	12 <sub>5,8;-3</sub>	56667	69870	68563	66999	66667	11 <sub>8,4,4</sub>	12 <sub>8,5,3</sub>
9 <sub>1,9;-8</sub>	10 <sub>2,9;-7</sub>	33000	21311	19566	19097	19000	9 <sub>9,1;8</sub>	10 <sub>9,2,7</sub>
10 <sub>2,9;-7</sub>	11 <sub>3,9;-6</sub>	41364	40664	37443	36548	36364	10 <sub>9,2,7</sub>	11 <sub>9,3,6</sub>
11 <sub>3,9;-6</sub>	12 <sub>4,9;-5</sub>	50000	58070	54050	52766	52500	11 <sub>9,3,6</sub>	12 <sub>9,4,5</sub>
10 <sub>1,10;-9</sub>	11 <sub>2,10;-8</sub>	35454	21431	19662	19189	19091	10 <sub>10,1;9</sub>	11 <sub>10,2;8</sub>
11 <sub>2,10;-8</sub>	12 <sub>3,10;-7</sub>	43750	41102	37761	36854	36667	11 <sub>10,2;8</sub>	12 <sub>10,3;7</sub>
11 <sub>1,11;-10</sub>	12 <sub>2,11;-9</sub>	37917	21526	19742	19265	19167	11 <sub>11,1,10</sub>	12 <sub>11,2,9</sub>

B.  $\sigma$  and  $c$  prolate-or-oblate sub-branches

Sub-branch							Sub-branch	
${}^{\sigma}Q1,2$	${}^cQ1,2$	$\mp 1$	$\mp 0.5$	$\kappa$ 0	$\pm 0.5$	$\pm 1$	${}^{\sigma}Q2,1$	${}^cQ3,1$
2,0,2	2,1,2;-1	8333	5110	2233	488		2,0,2;-2	2,2,1,1
3,2,1;1	3,1,3;-2	14583	5722	1328	165		3,1,2;-1	3,3,1;2
4,2,2;0	4,1,4;-3	20250	4363	650	78		4,2,2,0	4,4,1,3
5,2,3;-1	5,1,5;-4	25667	2859	374	54		5,3,2,1	5,5,1;4
6,2,4;-2	6,1,6;-5	30952	1843	266	43		6,4,2;2	6,6,1,5
7,2,5;-3	7,1,7;-6	36161	1262	218	35		7,5,2,3	7,7,1;6
8,2,6;-4	8,1,8;-7	41319	945	183	30		8,6,2;4	8,8,1,7
9,2,7;-5	9,1,9;-8	46444	770	160	26		9,7,2;5	9,9,1,8
10,2,8;-6	10,1,10;-9	51545	664	141	23		10,8,2,6	10,10,1,9
11,2,9;-7	11,1,11;-10	56629	590	125	21		11,9,2,7	11,11,1,10
12,2,10;-8	12,1,12;-11	61699	533	115	19		12,10,2,8	12,12,1,11
3,0,3	3,2,2,0	8750	7055	4522	1458		3,0,3;-3	3,2,2,0
4,3,1,2	4,2,3;-1	15750	11214	4568	638		4,1,3;-2	4,3,2,1
5,3,2;1	5,2,4;-2	22000	12576	2754	274		5,2,3;-1	5,4,2,2
6,3,3;0	6,2,5;-3	27857	11283	1492	171		6,3,3,0	6,5,2,3
7,3,4;-1	7,2,6;-4	33482	8559	925	132		7,4,3,1	7,6,2,4
8,3,5;-2	8,2,7;-5	38958	5932	685	108		8,5,3;2	8,7,2;5
9,3,6;-3	9,2,8;-6	44333	4077	567	92		9,6,3,3	9,8,2;6
10,3,7;-4	10,2,9;-7	49636	2945	490	80		10,7,3,4	10,9,2,7
11,3,8;-5	11,2,10;-8	54886	2294	433	71		11,8,3,5	11,10,2,8
12,3,9;-6	12,2,11;-9	60096	1917	387	64		12,9,3,6	12,11,2,9
4,4,0,4	4,3,2;1	9000	7558	5617	2547		4,0,4;-4	4,2,3;-1
5,4,1;3	5,3,3,0	16500	13242	7983	1599		5,1,4;-3	5,3,3,0
6,4,2;2	6,3,4;-1	23214	17320	6820	681		6,2,4;-2	6,4,3,1
7,4,3;1	7,3,5;-2	29464	19464	4223	374		7,3,4;-1	7,5,3,2
8,4,4;0	8,3,6;-3	35417	19178	2433	273		8,4,4,0	8,6,3;3
9,4,5;-1	9,3,7;-4	41167	16526	1579	222		9,5,4,1	9,7,3,4
10,4,6;-2	10,3,8;-5	46773	12665	1205	188		10,6,4;2	10,8,3,5
11,4,7;-3	11,3,9;-6	52273	9080	1014	163		11,7,4,3	11,9,3,6
12,4,8;-4	12,3,10;-7	57692	6485	888	144		12,8,4,4	12,10,3,7
5,5,0,5	5,4,2,2	9167	7775	6052	3368		5,0,5;-5	5,2,4;-2
6,5,1,4	6,4,3;1	17024	14062	9982	3054		6,1,5;-4	6,3,4;-1
7,5,2;3	7,4,4,0	24107	19225	11103	1459		7,2,5;-3	7,4,4,0
8,5,3,2	8,4,5;-1	30694	23287	9000	720		8,3,5;-2	8,5,4,1
9,5,4;1	9,4,6;-2	36944	26001	5708	481		9,4,5;-1	9,6,4,2
10,5,5,0	10,4,7;-3	42955	26852	3433	382		10,5,5,0	10,7,4,3
11,5,6;-1	11,4,8;-4	48788	25327	2306	321		11,6,5,1	11,8,4,4
12,5,7;-2	12,4,9;-5	54487	21546	1796	277		12,7,5,2	12,9,4,5
6,6,0,6	6,5,2,3	9286	7912	6257	3863		6,0,6;-6	6,2,5;-3
7,6,1;5	7,5,3;2	17411	14550	10952	4657		7,1,6;-5	7,3,5;-2
8,6,2,4	8,5,4;1	24792	20233	13841	2772		8,2,6;-4	8,4,5;-1
9,6,3;3	9,5,5;0	31667	25098	14023	1322		9,3,6;-3	9,5,5,0
10,6,4,2	10,5,6;-1	38182	29140	11121	785		10,4,6;-2	10,6,5,1
11,6,5,1	11,5,7;-2	44432	32202	7197	595		11,5,6;-1	11,7,5,2
12,6,6,0	12,5,8;-3	50481	33921	4472	494		12,6,6,0	12,8,5,3
7,7,0,7	7,6,2,4	9375	8011	6381	4141		7,0,7;-7	7,2,6;-4
8,7,1;6	8,6,3,3	17708	14899	11480	5982		8,1,7;-6	8,3,6;-3
9,7,2;5	9,6,4;2	25333	20930	15306	4603		9,2,7;-5	9,4,6;-2
10,7,3,4	10,6,5;1	32455	26247	17406	2348		10,3,7;-4	10,5,6;-1
11,7,4;3	11,6,6;0	39205	30913	16805	1258		11,4,7;-3	11,6,6;0
12,7,5;2	12,6,7;-1	45673	34922	13192	878		12,5,7;-2	12,7,6;1
8,8,0;8	8,7,2,5	9444	8087	6468	4302		8,0,8;-8	8,2,7;-5
9,8,1;7	9,7,3,4	17944	15167	11825	6888		9,1,8;-7	9,3,7;-4
10,8,2,6	10,7,4;3	25773	21462	16158	6602		10,2,8;-6	10,4,7;-3
11,8,3;5	11,7,5;2	33106	27105	19325	3955		11,3,8;-5	11,5,7;-2
12,8,4;4	12,7,6,1	40064	32170	20771	2027		12,4,8;-4	12,6,7;-1
9,9,0;9	9,8,7,6	9500	8146	6535	4403		9,0,9;-9	9,2,8;-6
10,9,1,8	10,8,3,5	18136	15380	12079	7464		10,1,9;-8	10,3,8;-5
11,9,2;7	11,8,4,4	26136	21887	16736	8319		11,2,9;-7	11,4,8;-4
12,9,3,6	12,8,5,3	33654	27788	20487	6108		12,3,9;-6	12,5,8;-3

Sub-branch							Sub-branch	
$^{\circ}Q_{1,2}$	$^{\circ}Q_{1,2}$	$\mp 1$	$\mp 0.5$	$\kappa$ 0	$\pm 0.5$	$\pm 1$	$^{\circ}Q_{2,1}$	$^{\circ}Q_{2,1}$
10 <sub>10,0,10</sub>	10 <sub>9,2,7</sub>	9545	8194	6588	4474		10 <sub>0,10,-10</sub>	10 <sub>2,9,-7</sub>
11 <sub>10,1,9</sub>	11 <sub>9,3,6</sub>	18295	15554	12279	7835		11 <sub>1,10,-9</sub>	11 <sub>3,9,-6</sub>
12 <sub>10,2,8</sub>	12 <sub>9,4,5</sub>	26442	22237	17173	9567		12 <sub>2,10,-8</sub>	12 <sub>4,9,-5</sub>
11 <sub>11,0,11</sub>	11 <sub>10,2,8</sub>	9583	8234	6631	4528		11 <sub>0,11,-11</sub>	11 <sub>2,10,-8</sub>
12 <sub>11,1,10</sub>	12 <sub>10,3,7</sub>	18429	15699	12443	8090		12 <sub>1,11,-10</sub>	12 <sub>3,10,-7</sub>
12 <sub>12,0,12</sub>	12 <sub>11,2,9</sub>	9615	8268	6667	4571		12 <sub>0,12,-12</sub>	12 <sub>2,11,-9</sub>
$^{\circ}R_{1,2}$	$^{\circ}P_{1,2}$	$\mp 1$	$\mp 0.5$	0	$\pm 0.5$	$\pm 1$	$^{\circ}R_{2,1}$	$^{\circ}P_{2,1}$
1 <sub>1,0,1</sub>	2 <sub>0,2,-2</sub>	5000	3066	1340	293		1 <sub>0,1,-1</sub>	2 <sub>2,0,2</sub>
2 <sub>1,1,0</sub>	3 <sub>0,3,-3</sub>	10000	4167	1086	157		2 <sub>1,1,0</sub>	3 <sub>3,0,3</sub>
3 <sub>1,2,-1</sub>	4 <sub>0,4,-4</sub>	15000	3944	800	123		3 <sub>2,1,1</sub>	4 <sub>4,0,4</sub>
4 <sub>1,3,-2</sub>	5 <sub>0,5,-5</sub>	20000	3386	696	117		4 <sub>3,1,2</sub>	5 <sub>5,0,5</sub>
5 <sub>1,4,-3</sub>	6 <sub>0,6,-6</sub>	25000	2976	667	114		5 <sub>4,1,3</sub>	6 <sub>6,0,6</sub>
6 <sub>1,5,-4</sub>	7 <sub>0,7,-7</sub>	30000	2770	656	112		6 <sub>5,1,4</sub>	7 <sub>7,0,7</sub>
7 <sub>1,6,-5</sub>	8 <sub>0,8,-8</sub>	35000	2686	649	111		7 <sub>6,1,5</sub>	8 <sub>8,0,8</sub>
8 <sub>1,7,-6</sub>	9 <sub>0,9,-9</sub>	40000	2652	644	110		8 <sub>7,1,6</sub>	9 <sub>9,0,9</sub>
9 <sub>1,8,-7</sub>	10 <sub>0,10,-10</sub>	45000	2634	640	109		9 <sub>8,1,7</sub>	10 <sub>10,0,10</sub>
10 <sub>1,9,-8</sub>	11 <sub>0,11,-11</sub>	50000	2621	637	109		10 <sub>9,1,8</sub>	11 <sub>11,0,11</sub>
11 <sub>1,10,-9</sub>	12 <sub>0,12,-12</sub>	55000	2610	634	108		11 <sub>10,1,9</sub>	12 <sub>12,0,12</sub>
2 <sub>2,0,2</sub>	3 <sub>1,2,-1</sub>	1667	2062	1905	776		2 <sub>0,2,-2</sub>	3 <sub>2,1,1</sub>
3 <sub>2,1,1</sub>	4 <sub>1,3,-2</sub>	3750	5114	2884	480		3 <sub>1,2,-1</sub>	4 <sub>3,1,2</sub>
4 <sub>2,2,0</sub>	5 <sub>1,4,-3</sub>	6000	7788	2336	310		4 <sub>2,2,0</sub>	5 <sub>4,1,3</sub>
5 <sub>2,3,-1</sub>	6 <sub>1,5,-4</sub>	8333	8748	1768	268		5 <sub>3,2,1</sub>	6 <sub>5,1,4</sub>
6 <sub>2,4,-2</sub>	7 <sub>1,6,-5</sub>	10714	8172	1529	254		6 <sub>4,2,2</sub>	7 <sub>6,1,5</sub>
7 <sub>2,5,-3</sub>	8 <sub>1,7,-6</sub>	13125	7135	1445	246		7 <sub>5,2,3</sub>	8 <sub>7,1,6</sub>
8 <sub>2,6,-4</sub>	9 <sub>1,8,-7</sub>	15556	6332	1406	240		8 <sub>6,2,4</sub>	9 <sub>8,1,7</sub>
9 <sub>2,7,-5</sub>	10 <sub>1,9,-8</sub>	18000	5885	1380	235		9 <sub>7,2,5</sub>	10 <sub>9,1,8</sub>
10 <sub>2,8,-6</sub>	11 <sub>1,10,-9</sub>	20455	5673	1360	232		10 <sub>8,2,6</sub>	11 <sub>10,1,9</sub>
11 <sub>2,9,-7</sub>	12 <sub>1,11,-10</sub>	22917	5570	1344	229		11 <sub>9,2,7</sub>	12 <sub>11,1,10</sub>
3 <sub>3,0,3</sub>	4 <sub>2,2,0</sub>	1250	1176	1316	1061		3 <sub>0,3,-3</sub>	4 <sub>2,2,0</sub>
4 <sub>3,1,2</sub>	5 <sub>2,3,-1</sub>	3000	3166	3516	1032		4 <sub>1,3,-2</sub>	5 <sub>3,2,1</sub>
5 <sub>3,2,1</sub>	6 <sub>2,4,-2</sub>	5000	6089	4448	613		5 <sub>2,3,-1</sub>	6 <sub>4,2,2</sub>
6 <sub>3,3,0</sub>	7 <sub>2,5,-3</sub>	7143	9630	3653	469		6 <sub>3,3,0</sub>	7 <sub>5,2,3</sub>
7 <sub>3,4,-1</sub>	8 <sub>2,6,-4</sub>	9375	12493	2828	426		7 <sub>4,3,1</sub>	8 <sub>6,2,4</sub>
8 <sub>3,5,-2</sub>	9 <sub>2,7,-5</sub>	11667	13383	2447	404		8 <sub>5,3,2</sub>	9 <sub>7,2,5</sub>
9 <sub>3,6,-3</sub>	10 <sub>2,8,-6</sub>	14000	12500	2301	389		9 <sub>6,3,3</sub>	10 <sub>8,2,6</sub>
10 <sub>3,7,-4</sub>	11 <sub>2,9,-7</sub>	16364	11048	2226	378		10 <sub>7,3,4</sub>	11 <sub>9,2,7</sub>
11 <sub>3,8,-5</sub>	12 <sub>2,10,-8</sub>	18750	9884	2174	370		11 <sub>8,3,5</sub>	12 <sub>10,2,8</sub>
4 <sub>4,0,4</sub>	5 <sub>3,2,1</sub>	1000	882	849	963		4 <sub>0,4,-4</sub>	5 <sub>2,3,-1</sub>
5 <sub>4,1,3</sub>	6 <sub>3,3,0</sub>	2500	2272	2651	1677		5 <sub>1,4,-3</sub>	6 <sub>3,3,0</sub>
6 <sub>4,2,2</sub>	7 <sub>3,4,-1</sub>	4286	4145	5108	1110		6 <sub>2,4,-2</sub>	7 <sub>4,3,1</sub>
7 <sub>4,3,1</sub>	8 <sub>3,5,-2</sub>	6250	6720	6025	747		7 <sub>3,4,-1</sub>	8 <sub>5,3,2</sub>
8 <sub>4,4,0</sub>	9 <sub>3,6,-3</sub>	8333	10196	5011	636		8 <sub>4,4,0</sub>	9 <sub>6,3,3</sub>
9 <sub>4,5,-1</sub>	10 <sub>3,7,-4</sub>	10500	14160	3947	590		9 <sub>5,4,1</sub>	10 <sub>7,3,4</sub>
10 <sub>4,6,-2</sub>	11 <sub>3,8,-5</sub>	12727	17215	3427	561		10 <sub>6,4,2</sub>	11 <sub>8,3,5</sub>
11 <sub>4,7,-3</sub>	12 <sub>3,9,-6</sub>	15000	18047	3214	540		11 <sub>7,4,3</sub>	12 <sub>9,3,6</sub>
5 <sub>5,0,5</sub>	6 <sub>4,2,2</sub>	833	730	638	723		5 <sub>0,5,-5</sub>	6 <sub>2,4,-2</sub>
6 <sub>5,1,4</sub>	7 <sub>4,3,1</sub>	2143	1898	1863	2013		6 <sub>1,5,-4</sub>	7 <sub>3,4,-1</sub>
7 <sub>5,2,3</sub>	8 <sub>4,4,0</sub>	3750	3384	4016	1833		7 <sub>2,5,-3</sub>	8 <sub>4,4,0</sub>
8 <sub>5,3,2</sub>	9 <sub>4,5,-1</sub>	5556	5182	6701	1165		8 <sub>3,5,-2</sub>	9 <sub>5,4,1</sub>
9 <sub>5,4,1</sub>	10 <sub>4,6,-2</sub>	7500	7437	7610	901		9 <sub>4,5,-1</sub>	10 <sub>6,4,2</sub>
10 <sub>5,5,0</sub>	11 <sub>4,7,-3</sub>	9545	10443	6398	809		10 <sub>5,5,0</sub>	11 <sub>7,4,3</sub>
11 <sub>5,6,-1</sub>	12 <sub>4,8,-4</sub>	11667	14380	5109	758		11 <sub>6,5,1</sub>	12 <sub>8,4,4</sub>
6 <sub>6,0,6</sub>	7 <sub>5,2,1</sub>	714	625	533	530		6 <sub>0,6,-6</sub>	7 <sub>2,5,-3</sub>
7 <sub>6,1,5</sub>	8 <sub>5,3,2</sub>	1875	1652	1470	1860		7 <sub>1,6,-5</sub>	8 <sub>3,5,-2</sub>
8 <sub>6,2,4</sub>	9 <sub>5,4,1</sub>	3333	2968	2958	2593		8 <sub>2,6,-4</sub>	9 <sub>4,5,-1</sub>
9 <sub>6,3,3</sub>	10 <sub>5,5,0</sub>	5000	4516	5406	1801		9 <sub>3,6,-3</sub>	10 <sub>5,5,0</sub>
10 <sub>6,4,2</sub>	11 <sub>5,6,-1</sub>	6818	6288	8298	1256		10 <sub>4,6,-2</sub>	11 <sub>6,5,1</sub>
11 <sub>6,5,1</sub>	12 <sub>5,7,-2</sub>	8750	8348	9203	1069		11 <sub>5,6,-1</sub>	12 <sub>7,5,2</sub>

Sub-branch							Sub branch	
$b \cdot P1.1$	$b \cdot P1 \bar{1}$	$\mp 1$	$\mp 0.5$	$0$	$\pm 0.5$	$\pm 1$	$b \cdot P1.1$	$b \cdot P1.1$
7 <sub>7.1,6</sub>	8 <sub>6,2,4</sub>	625	726	918	1615	28125	7 <sub>1,7,-6</sub>	8 <sub>2,6,-4</sub>
8 <sub>7,2,5</sub>	9 <sub>6,3,3</sub>	1667	1932	2461	5953	36667	8 <sub>2,7,-5</sub>	9 <sub>3,6,-3</sub>
9 <sub>7,3,4</sub>	10 <sub>6,4,2</sub>	3000	3467	4517	16387	45500	9 <sub>3,7,-4</sub>	10 <sub>4,6,-2</sub>
10 <sub>7,4,3</sub>	11 <sub>6,5,1</sub>	4545	5226	7432	32088	54546	10 <sub>4,7,-3</sub>	11 <sub>5,6,-1</sub>
11 <sub>7,5,2</sub>	12 <sub>6,6,0</sub>	6250	7131	12369	46152	63750	11 <sub>5,7,-2</sub>	12 <sub>6,6,0</sub>
8 <sub>8,1,7</sub>	9 <sub>7,2,5</sub>	556	645	816	1342	30556	8 <sub>1,8,-7</sub>	9 <sub>2,7,-5</sub>
9 <sub>8,2,6</sub>	10 <sub>7,3,4</sub>	1500	1741	2210	4454	39000	9 <sub>2,8,-6</sub>	10 <sub>3,7,-4</sub>
10 <sub>8,3,5</sub>	11 <sub>7,4,3</sub>	2727	3158	4030	12003	47727	10 <sub>3,8,-5</sub>	11 <sub>4,7,-3</sub>
11 <sub>8,4,4</sub>	12 <sub>7,5,2</sub>	4167	4808	6264	26503	56667	11 <sub>4,8,-4</sub>	12 <sub>5,7,-2</sub>
9 <sub>9,1,8</sub>	10 <sub>8,2,6</sub>	500	581	734	1176	33000	9 <sub>1,9,-8</sub>	10 <sub>2,8,-6</sub>
10 <sub>9,2,7</sub>	11 <sub>8,3,5</sub>	1364	1583	2009	3581	41364	10 <sub>2,9,-7</sub>	11 <sub>3,8,-5</sub>
11 <sub>9,3,6</sub>	12 <sub>8,4,4</sub>	2500	2898	3688	8874	50000	11 <sub>3,9,-6</sub>	12 <sub>4,8,-4</sub>
10 <sub>10,1,9</sub>	11 <sub>9,2,7</sub>	455	528	667	1059	35454	10 <sub>1,10,-9</sub>	11 <sub>2,9,-7</sub>
11 <sub>10,2,8</sub>	12 <sub>9,3,6</sub>	1250	1452	1841	3076	43750	11 <sub>2,10,-8</sub>	12 <sub>3,9,-6</sub>
11 <sub>11,1,10</sub>	12 <sub>10,2,8</sub>	417	484	611	967	37917	11 <sub>1,11,-10</sub>	12 <sub>2,10,-8</sub>

D. b prolate-or-oblate sub-branches.

$b \cdot P1.3$	$b \cdot P1.3$	$\mp 1$	$\mp 0.5$	$0$	$\pm 0.5$	$\pm 1$	$b \cdot P3.1$	$b \cdot P3.1$
2 <sub>2,0,2</sub>	3 <sub>1,3,-2</sub>	1667	1097	486	101		2 <sub>0,2,-2</sub>	3 <sub>3,1,2</sub>
3 <sub>2,1,1</sub>	4 <sub>1,4,-3</sub>	3750	1452	297	32		3 <sub>1,2,-1</sub>	4 <sub>4,1,3</sub>
4 <sub>2,2,0</sub>	5 <sub>1,5,-4</sub>	6000	1159	140	14		4 <sub>2,2,0</sub>	5 <sub>5,1,4</sub>
5 <sub>2,3,-1</sub>	6 <sub>1,6,-5</sub>	8333	758	77	9		5 <sub>3,2,1</sub>	6 <sub>6,1,5</sub>
6 <sub>2,4,-2</sub>	7 <sub>1,7,-6</sub>	10714	481	54	7		6 <sub>4,2,2</sub>	7 <sub>7,1,6</sub>
7 <sub>2,5,-3</sub>	8 <sub>1,8,-7</sub>	13125	323	42	6		7 <sub>5,2,3</sub>	8 <sub>8,1,7</sub>
8 <sub>2,6,-4</sub>	9 <sub>1,9,-8</sub>	15556	238	35	5		8 <sub>6,2,4</sub>	9 <sub>9,1,8</sub>
9 <sub>2,7,-5</sub>	10 <sub>1,10,-9</sub>	18000	191	30	4		9 <sub>7,2,5</sub>	10 <sub>10,1,9</sub>
10 <sub>2,8,-6</sub>	11 <sub>1,11,-10</sub>	20455	163	27	4		10 <sub>8,2,6</sub>	11 <sub>11,1,10</sub>
11 <sub>2,9,-7</sub>	12 <sub>1,12,-11</sub>	22917	144	24	3		11 <sub>9,2,7</sub>	12 <sub>12,1,11</sub>
3 <sub>3,0,3</sub>	4 <sub>2,3,-1</sub>	1250	1323	1091	416		3 <sub>0,3,-3</sub>	4 <sub>3,2,1</sub>
4 <sub>3,1,2</sub>	5 <sub>2,4,-2</sub>	3000	2753	1252	163		4 <sub>1,3,-2</sub>	5 <sub>4,2,2</sub>
5 <sub>3,2,1</sub>	6 <sub>2,5,-3</sub>	5000	3538	737	62		5 <sub>2,3,-1</sub>	6 <sub>5,2,3</sub>
6 <sub>3,3,0</sub>	7 <sub>2,6,-4</sub>	7143	3362	375	35		6 <sub>3,3,0</sub>	7 <sub>6,2,4</sub>
7 <sub>3,4,-1</sub>	8 <sub>2,7,-5</sub>	9375	2573	219	26		7 <sub>4,3,1</sub>	8 <sub>7,2,5</sub>
8 <sub>3,5,-2</sub>	9 <sub>2,8,-6</sub>	11667	1754	155	20		8 <sub>5,3,2</sub>	9 <sub>8,2,6</sub>
9 <sub>3,6,-3</sub>	10 <sub>2,9,-7</sub>	14000	1174	124	17		9 <sub>6,3,3</sub>	10 <sub>9,2,7</sub>
10 <sub>3,7,-4</sub>	11 <sub>2,10,-8</sub>	16364	826	104	14		10 <sub>7,3,4</sub>	11 <sub>10,2,8</sub>
11 <sub>3,8,-5</sub>	12 <sub>2,11,-9</sub>	18750	628	90	12		11 <sub>8,3,5</sub>	12 <sub>11,2,9</sub>
4 <sub>4,0,4</sub>	5 <sub>3,3,0</sub>	1000	1144	1259	855		4 <sub>0,4,-4</sub>	5 <sub>3,3,0</sub>
5 <sub>4,1,3</sub>	6 <sub>3,4,-1</sub>	2500	2771	2305	514		5 <sub>1,4,-3</sub>	6 <sub>4,3,1</sub>
6 <sub>4,2,2</sub>	7 <sub>3,5,-2</sub>	4286	4433	2107	189		6 <sub>2,4,-2</sub>	7 <sub>5,3,2</sub>
7 <sub>4,3,1</sub>	8 <sub>3,6,-3</sub>	6250	5663	1258	92		7 <sub>3,4,-1</sub>	8 <sub>6,3,3</sub>
8 <sub>4,4,0</sub>	9 <sub>3,7,-4</sub>	8332	6007	676	62		8 <sub>4,4,0</sub>	9 <sub>7,3,4</sub>
9 <sub>4,5,-1</sub>	10 <sub>3,8,-5</sub>	10500	5335	411	47		9 <sub>5,4,1</sub>	10 <sub>8,3,5</sub>
10 <sub>4,6,-2</sub>	11 <sub>3,9,-6</sub>	12727	4082	298	38		10 <sub>6,4,2</sub>	11 <sub>9,3,6</sub>
11 <sub>4,7,-3</sub>	12 <sub>3,10,-7</sub>	15000	2866	241	32		11 <sub>7,4,3</sub>	12 <sub>10,3,7</sub>
5 <sub>5,0,5</sub>	6 <sub>4,3,1</sub>	833	965	1174	1186		5 <sub>0,5,-5</sub>	6 <sub>3,4,-1</sub>
6 <sub>5,1,4</sub>	7 <sub>4,4,0</sub>	2143	2461	2707	1158		6 <sub>1,5,-4</sub>	7 <sub>4,4,0</sub>
7 <sub>5,2,3</sub>	8 <sub>4,5,-1</sub>	3750	4229	3560	488		7 <sub>2,5,-3</sub>	8 <sub>5,4,1</sub>
8 <sub>5,3,2</sub>	9 <sub>4,6,-2</sub>	5556	6040	3008	209		8 <sub>3,5,-2</sub>	9 <sub>6,4,2</sub>
9 <sub>5,4,1</sub>	10 <sub>4,7,-3</sub>	7500	7603	1831	125		9 <sub>4,5,-1</sub>	10 <sub>7,4,3</sub>
10 <sub>5,5,0</sub>	11 <sub>4,8,-4</sub>	9545	8531	1026	92		10 <sub>5,5,0</sub>	11 <sub>8,4,4</sub>
11 <sub>5,6,-1</sub>	12 <sub>4,9,-5</sub>	11667	8452	644	73		11 <sub>6,5,1</sub>	12 <sub>9,4,5</sub>
6 <sub>6,0,6</sub>	7 <sub>5,3,2</sub>	714	829	1039	1321		6 <sub>0,6,-6</sub>	7 <sub>3,5,-2</sub>
7 <sub>6,1,5</sub>	8 <sub>5,4,1</sub>	1875	2169	2640	1942		7 <sub>1,6,-5</sub>	8 <sub>4,5,-1</sub>
8 <sub>6,2,4</sub>	9 <sub>5,5,0</sub>	3333	3830	4213	1086		8 <sub>2,6,-4</sub>	9 <sub>5,5,0</sub>
9 <sub>6,3,3</sub>	10 <sub>5,6,-1</sub>	5000	5676	4833	447		9 <sub>3,6,-3</sub>	10 <sub>6,5,1</sub>
10 <sub>6,4,2</sub>	11 <sub>5,7,-2</sub>	6818	7575	3937	234		10 <sub>4,6,-2</sub>	11 <sub>7,5,2</sub>
11 <sub>6,5,1</sub>	12 <sub>5,8,-3</sub>	8750	9349	2441	161		11 <sub>5,6,-1</sub>	12 <sub>8,5,3</sub>

Sub branch							Sub branch	
$^{\infty}R\bar{1},2$	$^{\infty}P\bar{1},2$	$\mp 1$	$\mp 0.5$	0	$\pm 0.5$	$\pm 1$	$^{\infty}R2,\bar{1}$	$^{\infty}P2,\bar{1}$
7 <sub>7,1,6</sub>	8 <sub>6,3,3</sub>	625	546	462	341		7 <sub>1,7,-6</sub>	8 <sub>3,6,-3</sub>
8 <sub>7,2,5</sub>	9 <sub>6,4,2</sub>	1667	1465	1251	793		8 <sub>2,7,-5</sub>	9 <sub>4,6,-2</sub>
9 <sub>7,3,4</sub>	10 <sub>6,5,1</sub>	3000	2656	2267	1069		9 <sub>3,7,-4</sub>	10 <sub>5,6,-1</sub>
10 <sub>7,4,3</sub>	11 <sub>6,6,0</sub>	4545	4062	3368	1110		10 <sub>4,7,-3</sub>	11 <sub>6,6,0</sub>
11 <sub>7,5,2</sub>	12 <sub>6,7,-1</sub>	6250	5646	4336	1050		11 <sub>5,7,-2</sub>	12 <sub>7,6,1</sub>
8 <sub>8,1,7</sub>	9 <sub>7,3,4</sub>	556	485	411	317		8 <sub>1,8,-7</sub>	9 <sub>3,7,-4</sub>
9 <sub>8,2,6</sub>	10 <sub>7,4,3</sub>	1500	1316	1126	808		9 <sub>2,8,-6</sub>	10 <sub>4,7,-3</sub>
10 <sub>8,3,5</sub>	11 <sub>7,5,2</sub>	2727	2407	2082	1216		10 <sub>3,8,-5</sub>	11 <sub>5,7,-2</sub>
11 <sub>8,4,4</sub>	12 <sub>7,6,1</sub>	4167	3704	3209	1361		11 <sub>4,8,-4</sub>	12 <sub>6,7,-1</sub>
9 <sub>9,1,8</sub>	10 <sub>8,3,5</sub>	500	436	369	290		9 <sub>1,9,-8</sub>	10 <sub>3,8,-5</sub>
10 <sub>9,2,7</sub>	11 <sub>8,4,4</sub>	1304	1195	1021	786		10 <sub>2,9,-7</sub>	11 <sub>4,8,-4</sub>
11 <sub>9,3,6</sub>	12 <sub>8,5,3</sub>	2500	2201	1904	1296		11 <sub>3,9,-6</sub>	12 <sub>5,8,-3</sub>
10 <sub>10,1,9</sub>	11 <sub>9,3,6</sub>	455	397	335	265		10 <sub>1,10,-9</sub>	11 <sub>3,9,-6</sub>
11 <sub>10,2,8</sub>	12 <sub>9,4,5</sub>	1250	1094	931	741		11 <sub>2,10,-8</sub>	12 <sub>4,9,-5</sub>
11 <sub>11,1,10</sub>	12 <sub>10,3,7</sub>	417	363	307	243		11 <sub>1,11,-10</sub>	12 <sub>3,10,-7</sub>

## C. b prolate-and-oblate sub-branches

$^{\infty}Q\bar{1},1$	$^{\infty}Q1,1$	$\mp 1$	$\mp 0.5$	0	$\pm 0.5$	$\pm 1$	$^{\infty}Q1,\bar{1}$	$^{\infty}Q\bar{1},1$
1 <sub>1,0,1</sub>	1 <sub>0,1,-1</sub>	15000	15000	15000	15000	15000	1 <sub>0,1,-1</sub>	1 <sub>1,0,1</sub>
2 <sub>1,1,0</sub>	2 <sub>0,2,-2</sub>	25000	21289	16667	12044	8333	2 <sub>1,1,0</sub>	2 <sub>2,0,2</sub>
3 <sub>1,2,-1</sub>	3 <sub>0,3,-3</sub>	35000	23196	14583	10583	8750	3 <sub>2,1,1</sub>	3 <sub>3,0,3</sub>
4 <sub>1,3,-2</sub>	4 <sub>0,4,-4</sub>	45000	22157	13527	10617	9000	4 <sub>3,1,2</sub>	4 <sub>4,0,4</sub>
5 <sub>1,4,-3</sub>	5 <sub>0,5,-5</sub>	55000	20634	13413	10753	9167	5 <sub>4,1,3</sub>	5 <sub>5,0,5</sub>
6 <sub>1,5,-4</sub>	6 <sub>0,6,-6</sub>	65000	19779	13484	10861	9286	6 <sub>5,1,4</sub>	6 <sub>6,0,6</sub>
7 <sub>1,6,-5</sub>	7 <sub>0,7,-7</sub>	75000	19511	13559	10943	9375	7 <sub>6,1,5</sub>	7 <sub>7,0,7</sub>
8 <sub>1,7,-6</sub>	8 <sub>0,8,-8</sub>	85000	19487	13620	11008	9444	8 <sub>7,1,6</sub>	8 <sub>8,0,8</sub>
9 <sub>1,8,-7</sub>	9 <sub>0,9,-9</sub>	95000	19524	13669	11060	9500	9 <sub>8,1,7</sub>	9 <sub>9,0,9</sub>
10 <sub>1,9,-8</sub>	10 <sub>0,10,-10</sub>	105000	19565	13710	11103	9545	10 <sub>9,1,8</sub>	10 <sub>10,0,10</sub>
11 <sub>1,10,-9</sub>	11 <sub>0,11,-11</sub>	115000	19604	13744	11139	9583	11 <sub>10,1,9</sub>	11 <sub>11,0,11</sub>
12 <sub>1,11,-10</sub>	12 <sub>0,12,-12</sub>	125000	19633	13774	11170	9615	12 <sub>11,1,10</sub>	12 <sub>12,0,12</sub>
2 <sub>2,0,2</sub>	2 <sub>1,1,0</sub>	8333	12044	16667	21289	25000	2 <sub>0,2,-2</sub>	2 <sub>1,1,0</sub>
3 <sub>2,1,1</sub>	3 <sub>1,2,-1</sub>	14583	24417	28872	24417	14583	3 <sub>1,2,-1</sub>	3 <sub>2,1,1</sub>
4 <sub>2,2,0</sub>	4 <sub>1,3,-2</sub>	20250	36119	31154	20622	15750	4 <sub>2,2,0</sub>	4 <sub>3,1,2</sub>
5 <sub>2,3,-1</sub>	5 <sub>1,4,-3</sub>	25667	43650	28164	20038	16500	5 <sub>3,2,1</sub>	5 <sub>4,1,3</sub>
6 <sub>2,4,-2</sub>	6 <sub>1,5,-4</sub>	30952	45529	26402	20356	17024	6 <sub>4,2,2</sub>	6 <sub>5,1,4</sub>
7 <sub>2,5,-3</sub>	7 <sub>1,6,-5</sub>	36161	43602	26163	20670	17411	7 <sub>5,2,3</sub>	7 <sub>6,1,5</sub>
8 <sub>2,6,-4</sub>	8 <sub>1,7,-6</sub>	41319	41002	26300	20926	17708	8 <sub>6,2,4</sub>	8 <sub>7,1,6</sub>
9 <sub>2,7,-5</sub>	9 <sub>1,8,-7</sub>	46444	39408	26465	21134	17944	9 <sub>7,2,5</sub>	9 <sub>8,1,7</sub>
10 <sub>2,8,-6</sub>	10 <sub>1,9,-8</sub>	51545	38815	26611	21307	18136	10 <sub>8,2,6</sub>	10 <sub>9,1,8</sub>
11 <sub>2,9,-7</sub>	11 <sub>1,10,-9</sub>	56629	38701	26737	21452	18295	11 <sub>9,2,7</sub>	11 <sub>10,1,9</sub>
12 <sub>2,10,-8</sub>	12 <sub>1,11,-10</sub>	61699	38736	26846	21576	18429	12 <sub>10,2,8</sub>	12 <sub>11,1,10</sub>
3 <sub>3,0,3</sub>	3 <sub>2,1,1</sub>	8750	10583	14583	23196	35000	3 <sub>0,3,-3</sub>	3 <sub>1,2,-1</sub>
4 <sub>3,1,2</sub>	4 <sub>2,2,0</sub>	15750	20622	31154	36119	20250	4 <sub>1,3,-2</sub>	4 <sub>2,2,0</sub>
5 <sub>3,2,1</sub>	5 <sub>2,3,-1</sub>	22000	32340	44017	32340	22000	5 <sub>2,3,-1</sub>	5 <sub>3,2,1</sub>
6 <sub>3,3,0</sub>	6 <sub>2,4,-2</sub>	27857	45986	45920	29422	23214	6 <sub>3,3,0</sub>	6 <sub>4,2,2</sub>
7 <sub>3,4,-1</sub>	7 <sub>2,5,-3</sub>	33482	58783	41862	29481	24107	7 <sub>4,3,1</sub>	7 <sub>5,2,3</sub>
8 <sub>3,5,-2</sub>	8 <sub>2,6,-4</sub>	38958	66715	39333	29932	24792	8 <sub>5,3,2</sub>	8 <sub>6,2,4</sub>
9 <sub>3,6,-3</sub>	9 <sub>2,7,-5</sub>	44333	68174	38859	30348	25333	9 <sub>6,3,3</sub>	9 <sub>7,2,5</sub>
10 <sub>3,7,-4</sub>	10 <sub>2,8,-6</sub>	49636	65282	38980	30705	25773	10 <sub>7,3,4</sub>	10 <sub>8,2,6</sub>
11 <sub>3,8,-5</sub>	11 <sub>2,9,-7</sub>	54886	61636	39182	31011	26136	11 <sub>8,3,5</sub>	11 <sub>9,2,7</sub>
12 <sub>3,9,-6</sub>	12 <sub>2,10,-8</sub>	60096	59285	39377	31275	26442	12 <sub>9,3,6</sub>	12 <sub>10,2,8</sub>
4 <sub>4,0,4</sub>	4 <sub>3,1,2</sub>	9000	10617	13527	22157	45000	4 <sub>0,4,-4</sub>	4 <sub>1,3,-2</sub>
5 <sub>4,1,3</sub>	5 <sub>3,2,1</sub>	16500	20038	28164	43650	25667	5 <sub>1,4,-3</sub>	5 <sub>2,3,-1</sub>
6 <sub>4,2,2</sub>	6 <sub>3,3,0</sub>	23214	29422	45920	45986	27857	6 <sub>2,4,-2</sub>	6 <sub>3,3,0</sub>
7 <sub>4,3,1</sub>	7 <sub>3,4,-1</sub>	29464	39987	59402	39987	29464	7 <sub>3,4,-1</sub>	7 <sub>4,3,1</sub>
8 <sub>4,4,0</sub>	8 <sub>3,5,-2</sub>	35417	52950	60829	38601	30694	8 <sub>4,4,0</sub>	8 <sub>5,3,2</sub>
9 <sub>4,5,-1</sub>	9 <sub>3,6,-3</sub>	41167	67954	55712	38960	31667	9 <sub>5,4,1</sub>	9 <sub>6,3,3</sub>
10 <sub>4,6,-2</sub>	10 <sub>3,7,-4</sub>	46773	81732	52398	39466	32455	10 <sub>6,4,2</sub>	10 <sub>7,3,4</sub>
11 <sub>4,7,-3</sub>	11 <sub>3,8,-5</sub>	52273	89952	51626	39938	33106	11 <sub>7,4,3</sub>	11 <sub>8,3,5</sub>
12 <sub>4,8,-4</sub>	12 <sub>3,9,-6</sub>	57692	90961	51673	40360	33654	12 <sub>8,4,4</sub>	12 <sub>9,3,6</sub>

Sub branch							Sub-branch	
$b \cdot Q_{1,1}$	$b \cdot Q_{1,1}$	$\mp 1$	$\mp 0.5$	$0$	$\pm 0.5$	$\pm 1$	$b \cdot Q_{1,1}$	$b \cdot Q_{1,1}$
5 <sub>5,0,5</sub>	5 <sub>4,1,3</sub>	9167	10753	13413	20634	55000	5 <sub>0,5,-5</sub>	5 <sub>1,4,-3</sub>
6 <sub>5,1,4</sub>	6 <sub>4,2,2</sub>	17024	20356	26402	45529	30952	6 <sub>1,5,-4</sub>	6 <sub>2,4,-2</sub>
7 <sub>5,2,3</sub>	7 <sub>4,3,1</sub>	24107	29481	41862	58783	33482	7 <sub>2,5,-3</sub>	7 <sub>3,4,-1</sub>
8 <sub>5,3,2</sub>	8 <sub>4,4,0</sub>	30694	38601	60829	52950	35417	8 <sub>3,5,-2</sub>	8 <sub>4,4,0</sub>
9 <sub>5,4,1</sub>	9 <sub>4,5,-1</sub>	36944	48332	74882	48332	36944	9 <sub>4,5,-1</sub>	9 <sub>5,4,1</sub>
10 <sub>5,5,0</sub>	10 <sub>4,6,-2</sub>	42955	59745	75829	47998	38182	10 <sub>5,5,0</sub>	10 <sub>6,4,2</sub>
11 <sub>5,6,-1</sub>	11 <sub>4,7,-3</sub>	48788	73909	69690	48463	39205	11 <sub>6,5,1</sub>	11 <sub>7,4,0</sub>
12 <sub>5,7,-2</sub>	12 <sub>4,8,-4</sub>	54487	90148	65598	48989	40064	12 <sub>7,5,2</sub>	12 <sub>8,4,4</sub>
6 <sub>6,0,6</sub>	6 <sub>5,1,4</sub>	9286	10861	14484	19779	65000	6 <sub>0,6,-6</sub>	6 <sub>1,5,-4</sub>
7 <sub>6,1,5</sub>	7 <sub>5,2,3</sub>	17411	20670	26163	43602	36161	7 <sub>1,6,-5</sub>	7 <sub>2,5,-3</sub>
8 <sub>6,2,4</sub>	8 <sub>5,3,2</sub>	24792	29932	39333	66715	38958	8 <sub>2,6,-4</sub>	8 <sub>3,5,-2</sub>
9 <sub>6,3,3</sub>	9 <sub>5,4,1</sub>	31667	38960	55712	67954	41167	9 <sub>3,6,-3</sub>	9 <sub>4,5,-1</sub>
10 <sub>6,4,2</sub>	10 <sub>5,5,0</sub>	38182	47998	75829	59745	42955	10 <sub>4,6,-2</sub>	10 <sub>5,5,0</sub>
11 <sub>6,5,1</sub>	11 <sub>5,6,-1</sub>	44432	57343	90410	57343	44432	11 <sub>5,6,-1</sub>	11 <sub>6,5,1</sub>
12 <sub>6,6,0</sub>	12 <sub>5,7,-2</sub>	50481	67590	90893	57486	45673	12 <sub>6,6,0</sub>	12 <sub>7,5,2</sub>
7 <sub>7,0,7</sub>	7 <sub>6,1,5</sub>	9375	10943	13559	19511	75000	7 <sub>0,7,-7</sub>	7 <sub>1,6,5</sub>
8 <sub>7,1,6</sub>	8 <sub>6,2,4</sub>	17708	20926	26300	41002	41319	8 <sub>1,7,-6</sub>	8 <sub>2,6,-4</sub>
9 <sub>7,2,5</sub>	9 <sub>6,3,3</sub>	25333	30348	38859	68174	44333	9 <sub>2,7,-5</sub>	9 <sub>3,6,-3</sub>
10 <sub>7,3,4</sub>	10 <sub>6,4,2</sub>	32455	39466	52398	81732	46773	10 <sub>3,7,-4</sub>	10 <sub>4,6,-2</sub>
11 <sub>7,4,3</sub>	11 <sub>6,5,1</sub>	39205	48463	69690	73909	48788	11 <sub>4,7,-3</sub>	11 <sub>5,6,-1</sub>
12 <sub>7,5,2</sub>	12 <sub>6,6,0</sub>	45673	57486	90893	67590	50481	12 <sub>5,7,-2</sub>	12 <sub>6,6,0</sub>
8 <sub>8,0,8</sub>	8 <sub>7,1,6</sub>	9444	11008	13620	19487	85000	8 <sub>0,8,-8</sub>	8 <sub>1,7,-6</sub>
9 <sub>8,1,7</sub>	9 <sub>7,2,5</sub>	17944	21134	26465	39408	46444	9 <sub>1,8,-7</sub>	9 <sub>2,7,-5</sub>
10 <sub>8,2,6</sub>	10 <sub>7,3,4</sub>	25773	30705	38980	65282	49636	10 <sub>2,8,-6</sub>	10 <sub>3,7,-4</sub>
11 <sub>8,3,5</sub>	11 <sub>7,4,3</sub>	33106	39938	51626	89952	52273	11 <sub>3,8,-5</sub>	11 <sub>4,7,-3</sub>
12 <sub>8,4,4</sub>	12 <sub>7,5,2</sub>	40064	48989	65598	90148	54487	12 <sub>4,8,-4</sub>	12 <sub>5,7,-2</sub>
9 <sub>9,0,9</sub>	9 <sub>8,1,7</sub>	9500	11060	13669	19524	95000	9 <sub>0,9,-9</sub>	9 <sub>1,8,-7</sub>
10 <sub>9,1,8</sub>	10 <sub>8,2,6</sub>	18136	21307	26611	38815	51545	10 <sub>1,9,-8</sub>	10 <sub>2,8,-6</sub>
11 <sub>9,2,7</sub>	11 <sub>8,3,5</sub>	26136	31011	39182	61636	54886	11 <sub>2,9,-7</sub>	11 <sub>3,8,-5</sub>
12 <sub>9,3,6</sub>	12 <sub>8,4,4</sub>	33654	40360	51673	90961	57692	12 <sub>3,9,-6</sub>	12 <sub>4,8,-4</sub>
10 <sub>10,0,10</sub>	10 <sub>9,1,8</sub>	9545	11103	13710	19565	105000	10 <sub>0,10,-10</sub>	10 <sub>1,9,-8</sub>
11 <sub>10,1,9</sub>	11 <sub>9,2,7</sub>	18295	21452	26737	38701	56629	11 <sub>1,10,-9</sub>	11 <sub>2,9,-7</sub>
12 <sub>10,2,8</sub>	12 <sub>9,3,6</sub>	26442	31275	39377	59285	60096	12 <sub>2,10,-8</sub>	12 <sub>3,9,-6</sub>
11 <sub>11,0,11</sub>	11 <sub>10,1,9</sub>	9583	11139	13744	19604	115000	11 <sub>0,11,-11</sub>	11 <sub>1,10,-9</sub>
12 <sub>11,1,10</sub>	12 <sub>10,2,8</sub>	18429	21576	26846	38736	61699	12 <sub>1,11,-10</sub>	12 <sub>2,10,-8</sub>
12 <sub>12,0,12</sub>	12 <sub>11,1,10</sub>	9615	11170	13774	19633	125000	12 <sub>0,12,-12</sub>	12 <sub>1,11,-10</sub>
$b \cdot Q_{1,1}$	$b \cdot Q_{1,1}$	$\mp 1$	$\mp 0.5$	$0$	$\pm 0.5$	$\pm 1$	$b \cdot Q_{1,1}$	$b \cdot Q_{1,1}$
2 <sub>2,1,1</sub>	2 <sub>1,2,-1</sub>	8333	8333	8333	8333	8333	2 <sub>1,2,-1</sub>	2 <sub>2,1,1</sub>
3 <sub>2,2,0</sub>	3 <sub>1,3,-2</sub>	14583	13160	11667	10173	8750	3 <sub>2,2,0</sub>	3 <sub>3,1,2</sub>
4 <sub>2,3,-1</sub>	4 <sub>1,4,-3</sub>	20250	16126	12886	10584	9000	4 <sub>3,2,1</sub>	4 <sub>4,1,3</sub>
5 <sub>2,4,-2</sub>	5 <sub>1,5,-4</sub>	25667	17823	13300	10751	9167	5 <sub>4,2,2</sub>	5 <sub>5,1,4</sub>
6 <sub>2,5,-3</sub>	6 <sub>1,6,-5</sub>	30952	18716	13464	10860	9286	6 <sub>5,2,3</sub>	6 <sub>6,1,5</sub>
7 <sub>2,6,-4</sub>	7 <sub>1,7,-6</sub>	36161	19158	13555	10943	9375	7 <sub>6,2,4</sub>	7 <sub>7,1,6</sub>
8 <sub>2,7,-5</sub>	8 <sub>1,8,-7</sub>	41319	19374	13619	11008	9444	8 <sub>7,2,5</sub>	8 <sub>8,1,7</sub>
9 <sub>2,8,-6</sub>	9 <sub>1,9,-8</sub>	46444	19487	13669	11060	9500	9 <sub>8,2,6</sub>	9 <sub>9,1,8</sub>
10 <sub>2,9,-7</sub>	10 <sub>1,10,-9</sub>	51545	19553	13710	11103	9545	10 <sub>9,2,7</sub>	10 <sub>10,1,9</sub>
11 <sub>2,10,-8</sub>	11 <sub>1,11,-10</sub>	56629	19598	13744	11139	9583	11 <sub>10,2,8</sub>	11 <sub>11,1,10</sub>
12 <sub>2,11,-9</sub>	12 <sub>1,12,-11</sub>	61699	19632	13774	11170	9615	12 <sub>11,2,9</sub>	12 <sub>12,1,11</sub>
3 <sub>3,1,2</sub>	3 <sub>2,2,0</sub>	8750	10173	11667	13160	14583	3 <sub>1,3,-2</sub>	3 <sub>2,2,0</sub>
4 <sub>3,2,1</sub>	4 <sub>2,3,-1</sub>	15750	18280	19208	18280	15750	4 <sub>2,3,-1</sub>	4 <sub>3,2,1</sub>
5 <sub>3,3,0</sub>	5 <sub>2,4,-2</sub>	22000	24936	23333	19781	16500	5 <sub>3,3,0</sub>	5 <sub>4,2,2</sub>
6 <sub>3,4,-1</sub>	6 <sub>2,5,-3</sub>	27857	30089	25173	20331	17024	6 <sub>4,3,1</sub>	6 <sub>5,2,3</sub>
7 <sub>3,5,-2</sub>	7 <sub>2,6,-4</sub>	33482	33722	25914	20668	17411	7 <sub>5,3,2</sub>	7 <sub>6,2,4</sub>
8 <sub>3,6,-3</sub>	8 <sub>2,7,-5</sub>	38958	36030	26251	20926	17708	8 <sub>6,3,3</sub>	8 <sub>7,2,5</sub>
9 <sub>3,7,-4</sub>	9 <sub>2,8,-6</sub>	44333	37360	26455	21134	17944	9 <sub>7,3,4</sub>	9 <sub>8,2,6</sub>
10 <sub>3,8,-5</sub>	10 <sub>2,9,-7</sub>	49636	38072	26609	21307	18136	10 <sub>8,3,5</sub>	10 <sub>9,2,7</sub>
11 <sub>3,9,-6</sub>	11 <sub>2,10,-8</sub>	54886	38443	26737	21452	18295	11 <sub>9,3,6</sub>	11 <sub>10,2,8</sub>
12 <sub>3,10,-7</sub>	12 <sub>2,11,-9</sub>	60096	38646	26846	21576	18429	12 <sub>10,3,7</sub>	12 <sub>11,2,9</sub>

Sub-branch		$\kappa$					Sub-branch	
$^a \cdot Q1, \bar{1}$	$^b \cdot Q1, 1$	$\mp 1$	$\mp 0.5$	0	$\pm 0.5$	$\pm 1$	$^a \cdot Q1, \bar{1}$	$^b \cdot Q1, 1$
4 <sub>4,1,3</sub>	4 <sub>3,2,1</sub>	9000	10584	12886	16126	20250	4 <sub>1,4,-3</sub>	4 <sub>2,3,-1</sub>
5 <sub>4,2,2</sub>	5 <sub>3,3,0</sub>	16500	19781	23333	24936	22000	5 <sub>2,4,-2</sub>	5 <sub>3,3,0</sub>
6 <sub>4,3,1</sub>	6 <sub>3,4,-1</sub>	23214	28237	30910	28237	23214	6 <sub>3,4,-1</sub>	6 <sub>4,3,1</sub>
7 <sub>4,4,0</sub>	7 <sub>3,5,-2</sub>	29464	35974	35396	29347	24107	7 <sub>4,4,0</sub>	7 <sub>5,3,2</sub>
8 <sub>4,5,-1</sub>	8 <sub>3,6,-3</sub>	35417	42717	37550	29917	24792	8 <sub>5,4,1</sub>	8 <sub>6,3,3</sub>
9 <sub>4,6,-2</sub>	9 <sub>3,7,-4</sub>	41167	48149	38467	30347	25333	9 <sub>6,4,2</sub>	9 <sub>7,3,4</sub>
10 <sub>4,7,-3</sub>	10 <sub>3,8,-5</sub>	46773	52121	38896	30705	25773	10 <sub>7,4,3</sub>	10 <sub>8,3,5</sub>
11 <sub>4,8,-4</sub>	11 <sub>3,9,-6</sub>	52273	54738	39163	31011	26136	11 <sub>8,4,4</sub>	11 <sub>9,3,6</sub>
12 <sub>4,9,-5</sub>	12 <sub>3,10,-7</sub>	57692	56299	39373	31275	26442	12 <sub>9,4,5</sub>	12 <sub>10,3,7</sub>
5 <sub>5,1,4</sub>	5 <sub>4,2,2</sub>	9167	10751	13300	17823	25667	5 <sub>1,5,-4</sub>	5 <sub>2,4,-2</sub>
6 <sub>5,2,3</sub>	6 <sub>4,3,1</sub>	17024	20331	25173	30089	27857	6 <sub>2,5,-3</sub>	6 <sub>3,4,-1</sub>
7 <sub>5,3,2</sub>	7 <sub>4,4,0</sub>	24107	29347	35396	35974	29464	7 <sub>3,5,-2</sub>	7 <sub>4,4,0</sub>
8 <sub>5,4,1</sub>	8 <sub>4,5,-1</sub>	30694	38050	43061	38050	30694	8 <sub>4,5,-1</sub>	8 <sub>5,4,1</sub>
9 <sub>5,5,0</sub>	9 <sub>4,6,-2</sub>	36944	46432	47757	38893	31667	9 <sub>5,5,0</sub>	9 <sub>6,4,2</sub>
10 <sub>5,6,-1</sub>	10 <sub>4,7,-3</sub>	42955	54266	50083	39458	32455	10 <sub>6,5,1</sub>	10 <sub>7,4,3</sub>
11 <sub>5,7,-2</sub>	11 <sub>4,8,-4</sub>	48788	61181	51087	39937	33106	11 <sub>7,5,2</sub>	11 <sub>8,4,4</sub>
12 <sub>5,8,-3</sub>	12 <sub>4,9,-5</sub>	54487	66823	51551	40360	33654	12 <sub>8,5,3</sub>	12 <sub>9,4,5</sub>
6 <sub>6,1,5</sub>	6 <sub>5,2,3</sub>	9286	10860	13464	18716	30952	6 <sub>1,6,-5</sub>	6 <sub>2,5,-3</sub>
7 <sub>6,2,4</sub>	7 <sub>5,3,2</sub>	17411	20668	25914	33722	33482	7 <sub>2,6,-4</sub>	7 <sub>3,5,-2</sub>
8 <sub>6,3,3</sub>	8 <sub>5,4,1</sub>	24792	29917	37550	42717	35417	8 <sub>3,6,-1</sub>	8 <sub>4,5,-1</sub>
9 <sub>6,4,2</sub>	9 <sub>5,5,0</sub>	31667	38893	47757	46432	36944	9 <sub>4,6,-2</sub>	9 <sub>5,5,0</sub>
10 <sub>6,5,1</sub>	10 <sub>5,6,-1</sub>	38182	47745	55515	47745	38182	10 <sub>5,6,-1</sub>	10 <sub>6,5,1</sub>
11 <sub>6,6,0</sub>	11 <sub>5,7,-2</sub>	44432	56495	60341	48430	39205	11 <sub>6,6,0</sub>	11 <sub>7,5,2</sub>
12 <sub>6,7,-1</sub>	12 <sub>5,8,-3</sub>	50481	65013	62764	48985	40064	12 <sub>7,6,1</sub>	12 <sub>8,5,3</sub>
7 <sub>7,1,6</sub>	7 <sub>6,2,4</sub>	9375	10943	13555	19158	36161	7 <sub>1,7,-6</sub>	7 <sub>2,6,-4</sub>
8 <sub>7,2,5</sub>	8 <sub>6,3,3</sub>	17708	20926	26251	36030	38958	8 <sub>2,7,-5</sub>	8 <sub>3,6,-3</sub>
9 <sub>7,3,4</sub>	9 <sub>6,4,2</sub>	25333	30347	38467	48149	41167	9 <sub>3,7,-4</sub>	9 <sub>4,6,-2</sub>
10 <sub>7,4,3</sub>	10 <sub>6,5,1</sub>	32455	39458	50083	54266	42955	10 <sub>4,7,-3</sub>	10 <sub>5,6,-1</sub>
11 <sub>7,5,2</sub>	11 <sub>6,6,0</sub>	39205	48430	60341	56495	44432	11 <sub>5,7,-2</sub>	11 <sub>6,6,0</sub>
12 <sub>7,6,1</sub>	12 <sub>6,7,-1</sub>	45673	57370	68182	57370	45673	12 <sub>6,7,-1</sub>	12 <sub>7,6,1</sub>
8 <sub>8,1,7</sub>	8 <sub>7,2,5</sub>	9444	11008	13619	19374	41319	8 <sub>1,8,-7</sub>	8 <sub>2,7,-5</sub>
9 <sub>8,2,6</sub>	9 <sub>7,3,4</sub>	17944	21134	26455	37360	44333	9 <sub>2,8,-6</sub>	9 <sub>3,7,-4</sub>
10 <sub>8,3,5</sub>	10 <sub>7,4,3</sub>	25773	30705	38896	52121	46773	10 <sub>3,8,-5</sub>	10 <sub>4,7,-3</sub>
11 <sub>8,4,4</sub>	11 <sub>7,5,2</sub>	33106	39937	51087	61181	48788	11 <sub>4,8,-4</sub>	11 <sub>5,7,-2</sub>
12 <sub>8,5,3</sub>	12 <sub>7,6,1</sub>	40064	48985	62764	65013	50481	12 <sub>5,8,-3</sub>	12 <sub>6,7,-1</sub>
9 <sub>9,1,8</sub>	9 <sub>8,2,6</sub>	9500	11060	13669	19487	46444	9 <sub>1,9,-8</sub>	9 <sub>2,8,-6</sub>
10 <sub>9,2,7</sub>	10 <sub>8,3,5</sub>	18136	21307	26609	38072	49636	10 <sub>2,9,7</sub>	10 <sub>3,8,-5</sub>
11 <sub>9,3,6</sub>	11 <sub>8,4,4</sub>	26136	31011	39163	54738	52273	11 <sub>3,9,6</sub>	11 <sub>4,8,-4</sub>
12 <sub>9,4,5</sub>	12 <sub>8,5,3</sub>	33654	40360	51551	66823	54487	12 <sub>4,9,-5</sub>	12 <sub>5,8,-3</sub>
10 <sub>10,1,9</sub>	10 <sub>9,2,7</sub>	9545	11103	13710	19553	51545	10 <sub>1,10,-9</sub>	10 <sub>2,9,-7</sub>
11 <sub>10,2,8</sub>	11 <sub>9,3,6</sub>	18295	21452	26737	38443	54886	11 <sub>2,10,-8</sub>	11 <sub>3,9,-6</sub>
12 <sub>10,3,7</sub>	12 <sub>9,4,5</sub>	26442	31275	39373	56299	57692	12 <sub>3,10,-7</sub>	12 <sub>4,9,-5</sub>
11 <sub>11,1,10</sub>	11 <sub>10,2,8</sub>	9583	11139	13744	19598	56629	11 <sub>1,11,-10</sub>	11 <sub>2,10,-8</sub>
12 <sub>11,2,9</sub>	12 <sub>10,3,7</sub>	18429	21576	26846	38646	60096	12 <sub>2,11,-9</sub>	12 <sub>3,10,-7</sub>
12 <sub>12,1,11</sub>	12 <sub>11,2,9</sub>	9615	11170	13774	19632	61699	12 <sub>1,12,-11</sub>	12 <sub>2,11,-9</sub>
$^a \cdot R1, 1$	$^b \cdot P1, \bar{1}$	$\mp 1$	$\mp 0.5$	0	$\pm 0.5$	$\pm 1$	$^a \cdot R1, 1$	$^b \cdot P1, \bar{1}$
0 <sub>0,0,0</sub>	1 <sub>1,1,0</sub>	10000	10000	10000	10000	10000	0 <sub>0,0,0</sub>	1 <sub>1,1,0</sub>
1 <sub>1,0,1</sub>	2 <sub>2,1,1</sub>	15000	15000	15000	15000	15000	1 <sub>0,1,-1</sub>	2 <sub>1,2,-1</sub>
2 <sub>2,0,2</sub>	3 <sub>3,1,2</sub>	25000	24086	22847	21383	20000	2 <sub>0,2,-2</sub>	3 <sub>1,3,-2</sub>
3 <sub>3,0,3</sub>	4 <sub>4,1,3</sub>	35000	34083	32533	29584	25000	3 <sub>0,3,-3</sub>	4 <sub>1,4,-3</sub>
4 <sub>4,0,4</sub>	5 <sub>5,1,4</sub>	45000	44117	42585	39100	30000	4 <sub>0,4,-4</sub>	5 <sub>1,5,-4</sub>
5 <sub>5,0,5</sub>	6 <sub>6,1,5</sub>	55000	54140	52653	49126	35000	5 <sub>0,5,-5</sub>	6 <sub>1,6,-5</sub>
6 <sub>6,0,6</sub>	7 <sub>7,1,6</sub>	65000	64155	62702	59250	40000	6 <sub>0,6,-6</sub>	7 <sub>1,7,-6</sub>
7 <sub>7,0,7</sub>	8 <sub>8,1,7</sub>	75000	74165	72737	69364	45000	7 <sub>0,7,-7</sub>	8 <sub>1,8,-7</sub>
8 <sub>8,0,8</sub>	9 <sub>9,1,8</sub>	85000	84173	82763	79453	50000	8 <sub>0,8,-8</sub>	9 <sub>1,9,-8</sub>
9 <sub>9,0,9</sub>	10 <sub>10,1,9</sub>	95000	94179	92782	89522	55000	9 <sub>0,9,-9</sub>	10 <sub>1,10,-9</sub>
10 <sub>10,0,10</sub>	11 <sub>11,1,10</sub>	105000	104184	102798	99576	60000	10 <sub>0,10,-10</sub>	11 <sub>1,11,-10</sub>
11 <sub>11,0,11</sub>	12 <sub>12,1,11</sub>	115000	114188	112810	109620	65000	11 <sub>0,11,-11</sub>	12 <sub>1,12,-11</sub>

Sub branch							Sub branch	
$b \cdot R_{1,1}$	$b \cdot P_{1,1}$	F 1	$\mp 0.5$	$\pi$ 0	$\pm 0.5$	$\pm 1$	$b \cdot R_{1,1}$	$b \cdot P_{1,1}$
10,1,-1	21,2,-1	15000	15000	15000	15000	15000	11,0,1	22,1,1
21,1,0	32,2,0	16667	16667	16667	16667	16667	21,1,0	32,2,0
32,1,1	43,2,1	26250	23549	21079	19563	18750	31,2,-1	42,3,-1
43,1,2	54,2,2	36000	33165	28748	23919	21000	41,3,-2	52,4,-2
54,1,3	65,2,3	45833	43122	38409	30161	23333	51,4,-3	62,5,-3
65,1,4	76,2,4	55714	53091	48508	38383	25714	61,5,-4	72,6,-4
76,1,5	87,2,5	65625	63059	58609	48001	28125	71,6,-5	82,7,-5
87,1,6	98,2,6	75556	73030	68678	58192	30556	81,7,-6	92,8,-6
98,1,7	109,2,7	85500	83002	78720	68479	33000	91,8,-7	102,9,-7
109,1,8	1110,2,8	95455	92979	88749	78723	35454	101,9,-8	112,10,-8
1110,1,9	1211,2,9	105416	102958	98767	88911	37917	111,10,-9	122,11,-9
20,2,-2	31,3,-2	20000	21383	22847	24086	25000	22,0,2	33,1,2
31,2,-1	42,3,-1	18750	19563	21079	23549	26250	32,1,1	43,2,1
42,2,0	53,3,0	28000	23609	22028	23609	28000	42,2,0	53,3,0
53,2,1	64,3,1	37500	32338	26305	24633	30000	52,3,-1	63,4,-1
64,2,2	75,3,2	47143	42259	34093	27060	32143	62,4,-2	73,5,-2
75,2,3	86,3,3	56875	52226	43935	31293	34375	72,5,-3	83,6,-3
86,2,4	97,3,4	66667	62172	54199	37664	36667	82,6,-4	93,7,-4
97,2,5	108,3,5	76500	72110	64411	46127	39000	92,7,-5	103,8,-5
108,2,6	119,3,6	86364	82050	74550	56030	41364	102,8,-6	113,9,-6
119,2,7	1210,3,7	96250	91993	84638	66512	43750	112,9,-7	123,10,-7
30,3,-3	41,4,-3	25000	29584	32533	34083	35000	33,0,3	44,1,3
41,3,-2	52,4,-2	21000	23919	28748	33165	36000	43,1,2	54,2,2
52,3,-1	63,4,-1	30000	24633	26305	32338	37500	53,2,1	64,3,1
63,3,0	74,4,0	39286	31500	26801	31500	39286	63,3,0	74,4,0
74,3,1	85,4,1	48750	41277	31054	31018	41250	73,4,-1	84,5,-1
85,3,2	96,4,2	58333	51336	39046	31553	43333	83,5,-2	94,6,-2
96,3,3	107,4,3	68000	61325	49147	33704	45500	93,6,-3	104,7,-3
107,3,4	118,4,4	77727	71271	59638	37919	47727	103,7,-4	114,8,-4
118,3,5	129,4,5	87500	81200	70013	44472	50000	113,8,-5	124,9,-5
40,4,-4	51,5,-4	30000	39100	42585	44117	45000	44,0,4	55,1,4
51,4,-3	62,5,-3	23333	30161	38409	43122	45833	54,1,3	65,2,3
62,4,-2	73,5,-2	32143	27060	34093	42259	47143	64,2,2	75,3,2
73,4,-1	84,5,-1	41250	31018	31054	41277	48750	74,3,1	85,4,1
84,4,0	95,5,0	50556	40057	31211	40057	50556	84,4,0	95,5,0
95,4,1	106,5,1	60000	50269	35484	38709	52500	94,5,-1	105,6,-1
106,4,2	117,5,2	69546	60393	43709	37729	54546	104,6,-2	115,7,-2
117,4,3	128,5,3	79167	70407	54102	37878	56667	114,7,-3	125,8,-3
50,5,-5	61,6,-5	35000	49126	52653	54140	55000	55,0,5	66,1,5
61,5,-4	72,6,-4	25714	38383	48508	53091	55714	65,1,4	76,2,4
72,5,-3	83,6,-3	34375	31293	43935	52226	56875	75,2,3	86,3,3
83,5,-2	94,6,-2	43333	31553	39046	51336	58333	85,3,2	96,4,2
94,5,-1	105,6,-1	52500	38709	35484	50269	60000	95,4,1	106,5,1
105,5,0	116,6,0	61818	48913	35365	48913	61818	105,5,0	116,6,0
116,5,1	127,6,1	71250	59273	39679	47228	63750	115,6,-1	126,7,-1
60,6,-6	71,7,-6	40000	59250	62702	64155	65000	66,0,6	77,1,6
71,6,-5	82,7,-5	28125	48001	58609	63059	65625	76,1,5	87,2,5
82,6,-4	93,7,-4	36667	37664	54199	62172	66667	86,2,4	97,3,4
93,6,-3	104,7,-3	45500	33704	49147	61325	68000	96,3,3	107,4,3
104,6,-2	115,7,-2	54546	37729	43709	60393	69546	106,4,2	117,5,2
115,6,-1	126,7,-1	63750	47228	39679	59273	71250	116,5,1	127,6,1
70,7,-7	81,8,-7	45000	69364	72737	74165	75000	77,0,7	88,1,7
81,7,-6	92,8,-6	30556	58192	68678	73030	75556	87,1,6	98,2,6
92,7,-5	103,8,-5	39000	46127	64411	72110	76500	97,2,5	108,3,5
103,7,-4	114,8,-4	47727	37919	59638	71271	77727	107,3,4	118,4,4
114,7,-3	125,8,-3	56667	37878	54102	70407	79167	117,4,3	128,5,3
80,8,-8	91,9,-8	50000	79453	82763	84173	85000	88,0,8	99,1,8
91,8,-7	102,9,-7	33000	68479	78720	83002	85500	98,1,7	109,2,7
102,8,-6	113,9,-6	41364	56030	74550	82050	86364	108,2,6	119,3,6
113,8,-5	124,9,-5	50000	44472	70013	81200	87500	118,3,5	129,4,5

Sub branch							Sub-branch	
$b \cdot R_1$	$b \cdot P_1 \bar{I}$	$\mp 1$	$\mp 0.5$	$0$	$\pm 0.5$	$\pm 1$	$b \cdot R_{1,1}$	$b \cdot P_{1,1}$
9 <sub>0,9</sub> - <sub>9</sub>	10 <sub>1,10</sub> - <sub>9</sub>	55000	89522	92782	94179	95000	9 <sub>0,0,9</sub>	10 <sub>10,1,9</sub>
10 <sub>1,9</sub> - <sub>8</sub>	11 <sub>2,10</sub> - <sub>8</sub>	35454	78723	88749	92979	95455	10 <sub>9,1,8</sub>	11 <sub>10,2,8</sub>
11 <sub>2,9</sub> - <sub>7</sub>	12 <sub>3,10</sub> - <sub>7</sub>	43750	66512	84638	91993	96250	11 <sub>9,2,7</sub>	12 <sub>10,3,7</sub>
10 <sub>0,10</sub> - <sub>0</sub>	11 <sub>1,11</sub> - <sub>10</sub>	60000	99576	102798	104184	105000	10 <sub>10,0,10</sub>	11 <sub>11,1,10</sub>
11 <sub>1,10</sub> - <sub>9</sub>	12 <sub>2,11</sub> - <sub>9</sub>	37917	88911	98767	102958	105416	11 <sub>10,1,9</sub>	12 <sub>11,2,9</sub>
11 <sub>0,11</sub> - <sub>11</sub>	12 <sub>1,12</sub> - <sub>11</sub>	65000	109620	112810	114188	115000	11 <sub>11,0,11</sub>	12 <sub>12,1,11</sub>
$b \cdot R_{1,1}$	$b \cdot P_{1,1}$	$\mp 1$	$\mp 0.5$	$0$	$\pm 0.5$	$\pm 1$	$b \cdot R_{1,1}$	$b \cdot P_{1,1}$
1 <sub>1,1,0</sub>	2 <sub>0,2</sub> - <sub>2</sub>	5000	7226	10000	12774	15000	1 <sub>1,1,0</sub>	2 <sub>2,0,2</sub>
2 <sub>1,2</sub> - <sub>1</sub>	3 <sub>0,3</sub> - <sub>3</sub>	10000	16667	21498	23874	25000	2 <sub>2,1,1</sub>	3 <sub>3,0,3</sub>
3 <sub>1,3</sub> - <sub>2</sub>	4 <sub>0,4</sub> - <sub>4</sub>	15000	27406	32266	34065	35000	3 <sub>3,1,2</sub>	4 <sub>4,0,4</sub>
4 <sub>1,4</sub> - <sub>3</sub>	5 <sub>0,5</sub> - <sub>5</sub>	20000	38266	42535	44115	45000	4 <sub>4,1,3</sub>	5 <sub>5,0,5</sub>
5 <sub>1,5</sub> - <sub>3</sub>	6 <sub>0,6</sub> - <sub>6</sub>	25000	48829	52643	54140	55000	5 <sub>5,1,4</sub>	6 <sub>6,0,6</sub>
6 <sub>1,6</sub> - <sub>5</sub>	7 <sub>0,7</sub> - <sub>7</sub>	30000	59146	62700	64155	65000	6 <sub>6,1,5</sub>	7 <sub>7,0,7</sub>
7 <sub>1,7</sub> - <sub>6</sub>	8 <sub>0,8</sub> - <sub>8</sub>	35000	69327	72736	74165	75000	7 <sub>7,1,6</sub>	8 <sub>8,0,8</sub>
8 <sub>1,8</sub> - <sub>7</sub>	9 <sub>0,9</sub> - <sub>9</sub>	40000	79440	82762	84173	85000	8 <sub>8,1,7</sub>	9 <sub>9,0,9</sub>
9 <sub>1,9</sub> - <sub>8</sub>	10 <sub>0,10</sub> - <sub>10</sub>	45000	89517	92782	94179	95000	9 <sub>9,1,8</sub>	10 <sub>10,0,10</sub>
10 <sub>1,10</sub> - <sub>9</sub>	11 <sub>0,11</sub> - <sub>11</sub>	50000	99574	102798	104184	105000	10 <sub>10,1,9</sub>	11 <sub>11,0,11</sub>
11 <sub>1,11</sub> - <sub>10</sub>	12 <sub>0,12</sub> - <sub>12</sub>	55000	109619	112810	114188	115000	11 <sub>11,1,10</sub>	12 <sub>12,0,12</sub>
2 <sub>2,1,1</sub>	3 <sub>1,2</sub> - <sub>1</sub>	1667	2792	5168	10000	16667	2 <sub>1,2</sub> - <sub>1</sub>	3 <sub>2,1,1</sub>
3 <sub>2,2,0</sub>	4 <sub>1,3</sub> - <sub>2</sub>	3750	7602	15000	22398	26250	3 <sub>2,2,0</sub>	4 <sub>3,1,2</sub>
4 <sub>2,3</sub> - <sub>1</sub>	5 <sub>1,4</sub> - <sub>3</sub>	6000	14796	26797	33039	36000	4 <sub>3,2,1</sub>	5 <sub>4,1,3</sub>
5 <sub>2,4</sub> - <sub>2</sub>	6 <sub>1,5</sub> - <sub>4</sub>	8333	24389	37946	43109	45833	5 <sub>4,2,2</sub>	6 <sub>5,1,4</sub>
6 <sub>2,5</sub> - <sub>3</sub>	7 <sub>1,6</sub> - <sub>5</sub>	10714	35443	48405	53090	55714	6 <sub>5,2,3</sub>	7 <sub>6,1,5</sub>
7 <sub>2,6</sub> - <sub>4</sub>	8 <sub>1,7</sub> - <sub>6</sub>	13125	46736	58587	63059	65625	7 <sub>6,2,4</sub>	8 <sub>7,1,6</sub>
8 <sub>2,7</sub> - <sub>5</sub>	9 <sub>1,8</sub> - <sub>7</sub>	15556	57689	68672	73029	75556	8 <sub>7,2,5</sub>	9 <sub>8,1,7</sub>
9 <sub>2,8</sub> - <sub>6</sub>	10 <sub>1,9</sub> - <sub>8</sub>	18000	68283	78719	83002	85500	9 <sub>8,2,6</sub>	10 <sub>9,1,8</sub>
10 <sub>2,9</sub> - <sub>7</sub>	11 <sub>1,10</sub> - <sub>9</sub>	20455	78648	88749	92979	95455	10 <sub>9,2,7</sub>	11 <sub>10,1,9</sub>
11 <sub>2,10</sub> - <sub>8</sub>	12 <sub>1,11</sub> - <sub>10</sub>	22917	88882	98767	102958	105416	11 <sub>10,2,8</sub>	12 <sub>11,1,10</sub>
3 <sub>3,1,2</sub>	4 <sub>2,2,0</sub>	1250	1537	2692	6941	18750	3 <sub>1,3</sub> - <sub>2</sub>	4 <sub>2,2,0</sub>
4 <sub>3,2,1</sub>	5 <sub>2,3</sub> - <sub>1</sub>	3000	4022	8877	19900	28000	4 <sub>2,3</sub> - <sub>1</sub>	5 <sub>3,2,1</sub>
5 <sub>3,3,0</sub>	6 <sub>2,4</sub> - <sub>2</sub>	5000	7698	19335	31792	37500	5 <sub>3,3,0</sub>	6 <sub>4,2,2</sub>
6 <sub>3,4</sub> - <sub>1</sub>	7 <sub>2,5</sub> - <sub>3</sub>	7143	13138	31685	42193	47143	6 <sub>4,3,1</sub>	7 <sub>5,2,3</sub>
7 <sub>3,5</sub> - <sub>2</sub>	8 <sub>2,6</sub> - <sub>4</sub>	9375	20912	43306	52219	56875	7 <sub>5,3,2</sub>	8 <sub>6,2,4</sub>
8 <sub>3,6</sub> - <sub>3</sub>	9 <sub>2,7</sub> - <sub>5</sub>	11667	31041	54046	62172	66667	8 <sub>6,3,3</sub>	9 <sub>7,2,5</sub>
9 <sub>3,7</sub> - <sub>4</sub>	10 <sub>2,8</sub> - <sub>6</sub>	14000	42620	64375	72111	76500	9 <sub>7,3,4</sub>	10 <sub>8,2,6</sub>
10 <sub>3,8</sub> - <sub>5</sub>	11 <sub>2,9</sub> - <sub>7</sub>	16364	54434	74542	82050	86364	10 <sub>8,3,5</sub>	11 <sub>9,2,7</sub>
11 <sub>3,9</sub> - <sub>6</sub>	12 <sub>2,10</sub> - <sub>8</sub>	18750	65840	84638	91993	96250	11 <sub>9,3,6</sub>	12 <sub>10,2,8</sub>
4 <sub>4,1,3</sub>	5 <sub>3,2,1</sub>	1000	1162	1666	4522	21000	4 <sub>1,4</sub> - <sub>3</sub>	5 <sub>2,3</sub> - <sub>1</sub>
5 <sub>4,2,2</sub>	6 <sub>3,3,0</sub>	2500	2920	5238	16127	30000	5 <sub>2,4</sub> - <sub>2</sub>	6 <sub>3,3,0</sub>
6 <sub>4,3,1</sub>	7 <sub>3,4</sub> - <sub>1</sub>	4286	5148	12183	29700	39286	6 <sub>3,4</sub> - <sub>1</sub>	7 <sub>4,3,1</sub>
7 <sub>4,4,0</sub>	8 <sub>3,5</sub> - <sub>2</sub>	6250	8062	23299	41022	48750	7 <sub>4,4,0</sub>	8 <sub>5,3,2</sub>
8 <sub>4,5</sub> - <sub>1</sub>	9 <sub>3,6</sub> - <sub>3</sub>	8333	12161	36249	51302	58333	8 <sub>5,4,1</sub>	9 <sub>6,3,3</sub>
9 <sub>4,6</sub> - <sub>2</sub>	10 <sub>3,7</sub> - <sub>4</sub>	10500	18094	48371	61321	68000	9 <sub>6,4,2</sub>	10 <sub>7,3,4</sub>
10 <sub>4,7</sub> - <sub>1</sub>	11 <sub>3,8</sub> - <sub>5</sub>	12727	26418	59438	71271	77727	10 <sub>7,4,3</sub>	11 <sub>8,3,5</sub>
11 <sub>4,8</sub> - <sub>4</sub>	12 <sub>3,9</sub> - <sub>6</sub>	15000	37104	69962	81200	87500	11 <sub>8,4,4</sub>	12 <sub>9,3,6</sub>
5 <sub>5,1,4</sub>	6 <sub>4,2,2</sub>	833	966	1253	2984	23333	5 <sub>1,5</sub> - <sub>4</sub>	6 <sub>2,4</sub> - <sub>2</sub>
6 <sub>5,2,3</sub>	7 <sub>4,3,1</sub>	2143	2475	3549	11918	32143	6 <sub>2,5</sub> - <sub>3</sub>	7 <sub>3,4</sub> - <sub>1</sub>
7 <sub>5,3,2</sub>	8 <sub>4,4,0</sub>	3750	4309	7685	26263	41250	7 <sub>3,5</sub> - <sub>2</sub>	8 <sub>4,4,0</sub>
8 <sub>5,4,1</sub>	9 <sub>4,5</sub> - <sub>1</sub>	5556	6389	15266	39231	50556	8 <sub>4,5</sub> - <sub>1</sub>	9 <sub>5,4,1</sub>
9 <sub>5,5,0</sub>	10 <sub>4,6</sub> - <sub>2</sub>	7500	8819	27015	50150	60000	9 <sub>5,5,0</sub>	10 <sub>6,4,2</sub>
10 <sub>5,6</sub> - <sub>1</sub>	11 <sub>4,7</sub> - <sub>3</sub>	9545	11954	40562	60377	69546	10 <sub>6,5,1</sub>	11 <sub>7,4,3</sub>
11 <sub>5,7</sub> - <sub>2</sub>	12 <sub>4,8</sub> - <sub>4</sub>	11667	16365	53190	70405	79167	11 <sub>7,5,2</sub>	12 <sub>8,4,4</sub>
6 <sub>6,1,5</sub>	7 <sub>5,2,3</sub>	714	829	1052	2102	25714	6 <sub>1,6</sub> - <sub>5</sub>	7 <sub>2,5</sub> - <sub>3</sub>
7 <sub>6,2,4</sub>	8 <sub>5,3,2</sub>	1875	2170	2825	8386	34375	7 <sub>2,6</sub> - <sub>4</sub>	8 <sub>3,5</sub> - <sub>2</sub>
8 <sub>6,3,3</sub>	9 <sub>5,4,1</sub>	3333	3839	5485	21522	43333	8 <sub>3,6</sub> - <sub>3</sub>	9 <sub>4,5</sub> - <sub>1</sub>
9 <sub>6,4,2</sub>	10 <sub>5,5,0</sub>	5000	5717	10057	36378	52500	9 <sub>4,6</sub> - <sub>2</sub>	10 <sub>5,5,0</sub>
10 <sub>6,5,1</sub>	11 <sub>5,6</sub> - <sub>1</sub>	6818	7736	18198	48537	61818	10 <sub>5,6</sub> - <sub>1</sub>	11 <sub>6,5,1</sub>
11 <sub>6,6,0</sub>	12 <sub>5,7</sub> - <sub>2</sub>	8750	9912	30549	59217	71250	11 <sub>6,6,0</sub>	12 <sub>7,5,2</sub>

Sub-branch		±1	±0.5	κ 0	±0.5	±1	Sub branch	
κ RI,2	κ P1,2						κ R2,1	κ P2,1
7,0;7	8,6,2,4	625	546	463	411	7,0;7;-7	8,2,6;-4	
8,1;6	9,6,3,3	1667	1465	1267	1486	8,1;7;-6	9,3,6;-3	
9,2;5	10,6,4;2	3000	2656	2402	2962	9,2;7;-5	10,4,6;-2	
10,7,3;4	11,6,5,1	4545	4065	4106	2664	10,3;7;-4	11,5,6;-1	
11,7,4;3	12,6,6,0	6250	5659	6816	1772	11,4;7;-3	12,6,6;0	
8,0,8	9,7,2;5	556	485	411	341	8,0,8;-8	9,2;7;-5	
9,8,1;7	10,7,3,4	1500	1316	1129	1154	9,1,8;-7	10,3;7;-4	
10,8,2,6	11,7,4;3	2727	2407	2110	2759	10,2,8;-6	11,4;7;-3	
11,8,3,5	12,7,5,2	4167	3705	3398	3519	11,3,8;-5	12,5;7;-2	
9,0,9	10,8,2,6	500	436	369	298	9,0,9;-9	10,2,8;-6	
10,9,1,8	11,8,3,5	1364	1195	1021	932	10,1,9;-8	11,3,8;-5	
11,9,2,7	12,8,4,4	2500	2201	1910	2276	11,2,9;-7	12,4,8;-4	
10,10,0,10	11,9,2;7	455	397	335	268	10,0,10,-10	11,2,9;-7	
11,10,1,9	12,9,3;6	1250	1094	933	797	11,1,10,-9	12,3,9;-6	
11,11,0;11	12,10,2,8	417	363	307	244	11,0,11;-11	12,2,10;-8	
κ RI,2	κ P1,2	±1	±0.5	0	±0.5	±1	κ R2,1	κ P2,1
2,2,1;1	3,1,3,-2	1667	956	423	103	2,2;7;-1	3,3,1,2	
3,2,2;0	4,1,4;-3	3750	1742	609	118	3,2,2;0	4,4,1,3	
4,2,3;-1	5,1,5;-4	6000	2228	657	116	4,2,3;-1	5,5,1,4	
5,2,4;-2	6,1,6;-5	8333	2480	661	114	4,3,2;1	6,6,1,5	
6,2,5;-3	7,1,7;-6	10714	2590	655	112	5,4,2,2	7,7,1,6	
7,2,6;-4	8,1,8;-7	13125	2627	649	111	6,5,2,3	8,8,1,7	
8,2,7;-5	9,1,9;-8	15556	2633	644	110	7,6,2,4	9,9,1,8	
9,2,8;-6	10,1,10,-9	18000	2627	640	109	8,7,2,5	10,10,1,9	
10,2,9;-7	11,1,11;-10	20455	2619	637	109	9,8,2,6	11,11,1,10	
11,2,10;-8	12,1,12;-11	22917	2610	634	108	10,9,2,7	12,12,1,11	
						11,10,2,8		
3,3,1,2	4,2,3,-1	1250	1025	643	213	3,1,3,-2	4,3,2,1	
4,3,2,1	5,2,4,-2	3000	2317	1159	269	4,2,3;-1	5,4,2,2	
5,3,3,0	6,2,5;-3	5000	3522	1389	265	5,3,3,0	6,5,2,3	
6,3,4;-1	7,2,6;-4	7143	4450	1442	254	6,4,3,1	7,6,2,4	
7,3,5;-2	8,2,7;-5	9375	5049	1429	246	7,5,3,2	8,7,2,5	
8,3,6;-3	9,2,8;-6	11667	5372	1403	240	8,6,3,3	9,8,2,6	
9,3,7;-4	10,2,9,-7	14000	5507	1379	235	9,7,3,4	10,9,2,7	
10,3,8;-5	11,2,10,-8	16364	5539	1360	232	10,8,3,5	11,10,2,8	
11,3,9;-6	12,2,11,-9	18750	5523	1344	229	11,9,3,6	12,11,2,9	
4,4,1,3	5,3,3,0	1000	869	664	300	4,1,4;-3	5,3,3,0	
5,4,2,2	6,3,4;-1	2500	2168	1455	440	5,2,4;-2	6,4,3,1	
6,4,3,1	7,3,5;-2	4286	3662	2018	447	6,3,4;-1	7,5,3,2	
7,4,4,0	8,3,6;-3	6250	5157	2266	424	7,4,4,0	8,6,3,3	
8,4,5;-1	9,3,7;-4	8333	6471	2309	404	8,5,4,1	9,7,3,4	
9,4,6;-2	10,3,8;-5	10500	7475	2272	389	9,6,4,2	10,8,3,5	
10,4,7;-3	11,3,9;-6	12727	8130	2220	378	10,7,4,3	11,9,3,6	
11,4,8;-4	12,3,10,-7	15000	8481	2173	370	11,8,4,4	12,10,3,7	
5,5,1,4	6,4,3,1	833	729	601	346	5,1,5;-4	6,3,4,-1	
6,5,2,3	7,4,4,0	2143	1889	1489	603	6,2,5;-3	7,4,4,0	
7,5,3,2	8,4,5;-1	3750	3329	2360	656	7,3,5;-2	8,5,4,1	
8,5,4,1	9,4,6;-2	5556	4947	2953	626	8,4,5;-1	9,6,4,2	
9,5,5,0	10,4,7;-3	7500	6629	3209	589	9,5,5,0	10,7,4,3	
10,5,6;-1	11,4,8;-4	9545	8239	3235	561	10,6,5,1	11,8,4,4	
11,5,7;-2	12,4,9;-5	11667	9627	3171	540	11,7,5,2	12,9,4,5	
6,6,1,5	7,5,3,2	714	625	527	357	6,1,6,-5	7,3,5,-2	
7,6,2,4	8,5,4,1	1875	1651	1386	726	7,2,6,-4	8,4,5;-1	
8,6,3,3	9,5,5,0	3333	2962	2400	873	8,3,6;-3	9,5,5,0	
9,6,4,2	10,5,6;-1	5000	4489	3326	858	9,4,6,-2	10,6,5,1	
10,6,5,1	11,5,7;-2	6818	6181	3940	804	10,5,6,-1	11,7,5,2	
11,6,6,0	12,5,8;-3	8750	7975	4195	758	11,6,6,0	12,8,5,3	

$b, \sigma R \Gamma, 3$	Sub branch $b, \sigma P' 1, 3$	$\mp 1$	$\mp 0.5$	$\kappa$ 0	$\pm 0.5$	$\pm 1$	$b, \sigma R 3, \bar{1}$	Sub-branch $b, \sigma P' 3, 1$
7 <sub>7,0,7</sub>	8 <sub>6,3,3</sub>	625	726	916	1313		7 <sub>0,7,-7</sub>	8 <sub>3,6,-3</sub>
8 <sub>7,1,6</sub>	9 <sub>6,4,2</sub>	1667	1932	2426	2561		8 <sub>1,7,-6</sub>	9 <sub>4,6,-2</sub>
9 <sub>7,2,5</sub>	10 <sub>6,5,1</sub>	3000	3466	4214	2032		9 <sub>2,7,-5</sub>	10 <sub>5,6,-1</sub>
10 <sub>7,3,4</sub>	11 <sub>6,6,0</sub>	4545	5221	5738	917		10 <sub>3,7,-4</sub>	11 <sub>6,6,0</sub>
11 <sub>7,4,3</sub>	12 <sub>6,7,-1</sub>	6250	7114	6113	427		11 <sub>4,7,-3</sub>	12 <sub>7,6,1</sub>
8 <sub>8,0,8</sub>	9 <sub>7,3,4</sub>	556	645	816	1238		8 <sub>0,8,-8</sub>	9 <sub>3,7,-4</sub>
9 <sub>8,1,7</sub>	10 <sub>7,4,3</sub>	1500	1711	2204	2870		9 <sub>1,8,-7</sub>	10 <sub>4,7,-3</sub>
10 <sub>8,2,6</sub>	11 <sub>7,5,2</sub>	2727	3158	3967	3126		10 <sub>2,8,-6</sub>	11 <sub>5,7,-2</sub>
11 <sub>8,3,5</sub>	12 <sub>7,6,1</sub>	4167	4807	5836	1752		11 <sub>3,8,-5</sub>	12 <sub>6,7,-1</sub>
9 <sub>9,0,9</sub>	10 <sub>8,3,5</sub>	500	581	734	1143		9 <sub>0,9,-9</sub>	10 <sub>3,8,-5</sub>
10 <sub>9,1,8</sub>	11 <sub>8,4,4</sub>	1364	1583	2008	2924		10 <sub>1,9,-8</sub>	11 <sub>4,8,-4</sub>
11 <sub>9,2,7</sub>	12 <sub>8,5,3</sub>	2500	2898	3676	4014		11 <sub>2,9,-7</sub>	12 <sub>5,8,-3</sub>
10 <sub>10,0,10</sub>	11 <sub>9,3,6</sub>	455	528	667	1049		10 <sub>0,10,-10</sub>	11 <sub>3,9,-6</sub>
11 <sub>10,1,9</sub>	12 <sub>9,4,5</sub>	1250	1452	1841	2831		11 <sub>1,10,-9</sub>	12 <sub>4,9,-5</sub>
11 <sub>11,0,11</sub>	12 <sub>10,3,7</sub>	417	484	611	964		11 <sub>0,11,-11</sub>	12 <sub>3,10,-7</sub>

### APPENDIX III

## ROTATIONAL MAGNETIC MOMENT MATRIX ELEMENTS

ROTATIONAL magnetic moment matrix elements on the space-fixed Z(M) axis.

### 1. General Molecule

$(J, K, M | \mu_z | J, K, M)$

$$= \mu_0 M \left\{ \frac{g_{xx} + g_{yy}}{2} + \frac{K^2}{J(J+1)} \left[ g_{zz} - \frac{g_{xx} + g_{yy}}{2} \right] + i \frac{K}{J(J+1)} \left[ \frac{g_{yx} - g_{yx}^*}{2} - \frac{g_{xy} - g_{xy}^*}{2} \right] \right\}$$

$$(J, K, M | \mu_z | J, K+1, M) = \mu_0 M \frac{[J(J+1) - K(K+1)]^{\frac{1}{2}}}{4J(J+1)} \times \{ i[K(g_{zx} + g_{zx}^*) + (K+1)(g_{xz} + g_{xz}^*)] + K(g_{zy} + g_{zy}^*) + (K+1)(g_{yz} + g_{yz}^*) \}$$

$$(J, K, M | \mu_z | J, K+2, M) = \mu_0 M \frac{\{ [J(J+1) - K(K+1)][J(J+1) - (K+1)(K+2)] \}^{\frac{1}{2}}}{8J(J+1)} \times \{ 2(g_{yy} - g_{xx}) + i[g_{xy} + g_{xy}^* + g_{yx} + g_{yx}^*] \}$$

$(J, K, M | \mu_z | J+1, K, M)$

$$= \frac{1}{2(J+1)} \left\{ \frac{[(J+1)^2 - K^2][(J+1)^2 - M^2]}{(2J+1)(2J+3)} \right\}^{\frac{1}{2}} \times \{ K(2g_{zz} - g_{xx} - g_{yy}) - i[J(g_{xy} - g_{yx}) + (J+2)(g_{xy}^* - g_{yx}^*)] \}$$

$(J, K, M | \mu_z | J \pm 1, K \pm 1, M)$

$$= \frac{1}{2(J+1)} \left\{ \frac{(J \pm K + 1)(J \pm K + 2)[(J+1)^2 - M^2]}{(2J+1)(2J+3)} \right\}^{\frac{1}{2}} \\ \times \{ -K(i g_{xz} \pm g_{yz}) - (K \pm 1)(i g_{xz}^* \pm g_{yz}^*) \\ + (J \pm K)(g_{zy} \pm g_{zx}) + (J \pm K + 1)(g_{zy}^* \pm i g_{zx}^*) \}$$

$$, K, M | \mu_z | J \pm 1, K \pm 2, M) = \frac{1}{4(J+1)}$$

$$\left\{ \frac{(J \pm K)(J \pm K + 1)(J \pm K + 2)(J \pm K + 3)[(J+1)^2 - M^2]}{(2J+1)(2J+3)} \right\}^{\frac{1}{2}} \\ \times \{ \pm (g_{xx} - g_{yy}) - \frac{1}{2}i(g_{xy} + g_{xy}^* + g_{yx} + g_{yx}^*) \}$$

## 2. Special Cases

*A. Linear Rotor* (ground bending vibrational state):  $z$  refers to nuclear axis, thus  $g_{xx} = g_{yy}, g_{zz} = 0$ ,

$$(J, M | \mu_z | J, M) = \mu_0 M g_{xx}$$

*B. Symmetric Rotor*:  $z$  refers to symmetry axis, thus  $g_{xx} = g_{yy}$ .

$$(J, K, M | \mu_z | J, K, M) = \mu_0 M \{ g_{xx} + (g_{zz} - g_{xx}) K^2 / J(J+1) \}$$

$$(J, K, M | \mu_z | J+1, K, M)$$

$$= \frac{\mu_0 (g_{zz} - g_{xx})}{(J+1)} \left\{ \frac{[(J+1)^2 - K^2][(J+1)^2 - M^2]}{(2J+1)(2J+3)} \right\}^{\frac{1}{2}}$$

Note: the total matrix may be constructed from its hermitian property. The  $g_{gg'}$ 's are dimensionless and defined by

$$g_{gg'} = h G_{gg'} / \mu_0$$

where  $\mu_0$  is the nuclear magnetron,  $\mu_0 = e\hbar/2M_p c$ .

## INDEX

- ABSORPTION cell length, 91  
Absorption coefficient  
  General, 71  
  Linear rotor, 74  
  Non-resonant, 74  
Angular momentum  
  Electronic, 57  
  General, 2  
  Spin, 37, 75  
  Vibrational, 19, 21
- CENTRIFUGAL distortion  
  General, 28  
  Linear rotor, 29  
  Symmetric top, 29  
Commutation relations  
  Angular momentum, 2  
  Coordinate, 34  
  Direction cosine, 3  
  Harmonic oscillator, 21  
  Spin, 33, 78  
Continued fraction expansion, 12,  
  13, 23, 46, 58, 85  
Conversion gain, 90
- DENSITY matrix, 64  
Diagonalizing transformation, 13–  
  15
- ELECTRICAL breakdown, 98  
Electric dipole moment  
  General, 45, 64  
  Nuclear, 31  
  Symmetric top, 48  
Energy  
  General, 1  
  Quadrupole, 32  
  Reduced, 7, 116
- Energy (*contd.*)—  
  Rotational, 2, 17  
    and electronic, 57, 59, 62  
    and spin, 76  
    and vibrational, 21  
  Spin-spin, 76–77  
  Vibrational, 20, 22, 82
- FREQUENCY stabilizer, 94
- $\kappa$ , asymmetry factor, 6
- LINE breadth, 71, 73, 95, 103  
Line strength, 41, 50, 72, 122
- MATRIX elements  
  Angular momentum, 3, 5, 16, 17  
  Coordinate, 34  
  Direction cosines, 4  
  Harmonic oscillator, 22, 82  
  Hindering potential, 82–84  
  Reduced energy, 7, 10, 15  
  Rotational energy, 5–7  
  Spin, 78  
  Symmetrizing transformation, 9  
Molecular susceptibility, 65
- NOISE  
  Amplifier, 90, 104  
  Detector, 90  
  Guide, 96  
  Oscillator, 89
- RECIPROCAL moment of inertia,  
  6, 26, 27, 63  
Relative intensities, components  
  Quadrupole, 43  
  Stark, 74  
  Zeeman, 74

- SATURATION of absorption, 73  
Secular determinant, 9, 79, 80, 83  
Selection rules, 43, 51, 52, 61, 73,  
74, 80, 85, 86  
Stark effect  
  Degeneracies, 47, 48  
  General, 47  
  Higher order terms, 53  
Stark effect (*contd.*)—  
  Linear rotor, 49  
  Symmetric top, 48  
Sweep rate, 111, 112  
 $\tau$ , rotational state index, 17, 18  
WIGNER coefficients, 37













