

Pages Miss Within The Book Only

UNIVERSAL
LIBRARY

OU_156988

UNIVERSAL
LIBRARY

OSMANIA UNIVERSITY LIBRARY

Call No. 537.7 / N 54L Accession No. 4261

Author Nichols, E. L.

Title Laboratory Manual electricity

This book should be returned on or before the date last marked below.

A LABORATORY MANUAL
OF
PHYSICS AND APPLIED ELECTRICITY



THE MACMILLAN COMPANY
NEW YORK · BOSTON · CHICAGO
SAN FRANCISCO

MACMILLAN & CO., LIMITED
LONDON · BOMBAY · CALCUTTA
MELBOURNE

THE MACMILLAN CO. OF CANADA, Ltd.
TORONTO

A LABORATORY MANUAL
OF
PHYSICS AND APPLIED ELECTRICITY

ARRANGED AND EDITED
BY
EDWARD L. NICHOLS
PROFESSOR OF PHYSICS IN CORNELL UNIVERSITY

IN TWO VOLUMES
VOL. I
JUNIOR COURSE IN GENERAL PHYSICS
REVISED AND REWRITTEN BY
ERNEST BLAKER
ASSISTANT PROFESSOR OF PHYSICS IN CORNELL UNIVERSITY

New York
THE MACMILLAN COMPANY

1919

All rights reserved

COPYRIGHT, 1894, 1912,
By THE MACMILLAN COMPANY.

Set up and electrotyped. Published February, 1912. Reprinted
January, 1915.

Norwood Press
J. S. Cushing Co. — Berwick & Smith Co.
Norwood, Mass., U.S.A.

PREFACE TO FIRST EDITION.



THIS work has been written to supply in some measure the needs of a modern laboratory, in which the existing manuals of physics have been found inadequate. In its present form the book is the work, chiefly, of Assistant Professors George S. Moler, Ernest Merritt, and Frederick Bedell, of Instructors Frederick J. Rogers, Homer J. Hotchkiss, Charles P. Matthews, and of the editor. Certain parts, however, have been taken from written directions to students which had been prepared by instructors who are no longer members of the department from which the book emanates, and who have taken no immediate hand in its final preparation.

No attempt has been made to provide a complete and sufficient source of information for laboratory students. On the contrary, it has been thought wise to encourage continual reference to other works and to original sources. It is assumed that in all laboratories in which a work of this kind will be found useful, there is accessible to the student a small collection of reference volumes, including the Laboratory Manuals of Kohlrausch, Glazebrook and Shaw, Stewart and Gee, Witz, and of Wiedemann and Ebert; also that the larger treatises on experimental physics of Jamin, Winkelmann, Violle, Wiedemann, Preston, etc., together with the best known of the lesser works in English, are available.

The Manual has been divided into two volumes; and it is designed for three classes of students, differing from each other in experience, maturity, and purpose. The method of treatment has been varied in accordance with the principle, that with increasing experience the student should be divorced more and more from the use of the Manual

and also from the close supervision of the instructor, and that he should be thrown gradually upon his own resources, and be led to make a wider and wider use of the literature of the science.

It will be found that the first volume, which is intended for beginners, affords explicit directions, together with demonstrations and occasional elementary statements of principles. This volume is the outgrowth of a system of junior instruction which has been gradually developed during a quarter of a century. No attempt has been made to include the whole of physics. On the other hand, the principle has been followed here, as indeed throughout the book, of incorporating only such experiments as have been in actual use.

It is assumed that the student possesses some knowledge of analytical geometry and of the calculus; also that he has completed a textbook and lecture course in the principles of physics. It is not expected that the experiments will be taken consecutively, nor that a student, in the time usually given to the work, will complete more than a third of them. The experiments have been divided into groups, an arrangement of the work for which there were two reasons. On the one hand, it serves to guide the practicant and the instructor in the selection of experiments; on the other hand, it furthers the development of the system by making it easy to add or to exclude material. It is expected, indeed, that the book will be used thus by those into whose hands it may come, each one adding such experiments to the various groups as he may desire to include in his course, and dropping out those which he may deem useless.

In the second volume more is left to the individual effort and to the maturer intelligence of the practicant. This volume differs from the first also in another respect. In the junior course no attempt is made to leave the beaten track. The very nature of the subjects with which we have to deal in Volume II, however, has compelled the introduction of new materials. The writers trust that where the ripeness and maturity of treatment which comes from long-continued experience in the teaching of a subject is missing, some recompense may be found in the freshness and novelty of the themes.

A large proportion of the students, for whom primarily this Manual is intended, are preparing to become engineers, and especial attention has been devoted to the needs of that class of readers. In Parts I, II, and III of Volume II, especially, a considerable amount of work in applied electricity, in photometry, and in heat has been introduced, with particular reference to the training of students of engineering. It is believed, nevertheless, that selections from these parts may be made which will be of value to students of pure physics also.

The final chapters (Part IV), which are intended for those who have already had two years or more of laboratory instruction, consist simply of certain hints for advanced work. These are accompanied by typical results, the object of which is to show in brief form what has already been accomplished by the methods proposed, and to lead the student to a suitable starting-point for further investigation. Throughout this portion of the book theory and experimental detail alike have been omitted. The outlines which have been given are designed to afford suggestions only, and by virtue of their very meagreness to compel the student to read original memoirs in preparation for his work.

EDWARD L. NICHOLS.

CORNELL UNIVERSITY, ITHACA, NEW YORK,
May, 1894.

PREFACE TO SECOND EDITION.



SINCE the first edition of this manual was published, changes have been made in the treatment of many of the experiments. A few are no longer given and about forty others have been added to the list. The publication of a new edition has made possible the incorporation of these changes and new experiments. As a result, the book has been almost entirely rewritten. The changes and additions have extended over a period of years, and many of them have been due to members of the teaching staff no longer in the work. It is a great pleasure to make acknowledgment to all such, and especially to Professor John S. Shearer of Cornell University, Professor Oscar M. Stewart of the University of Missouri, Professor O. A. Gage of the University of Wisconsin, and Professor F. K. Richtmyer of Cornell University.

ERNEST BLAKER.

CORNELL UNIVERSITY,
November, 1911.

TABLE OF CONTENTS.

VOLUME I.

| | PAGE |
|---|------------|
| INTRODUCTION | I |
| Record of Observations. Units. Graphical Representation of Results. Errors of Observations and Method of Least Squares. | |
| CHAPTER I | 29 |
| Curvature of a Lens by the Spectrometer. Calibration of a Thermometer Tube. Volumes and Densities by Measurement. Time of Periodic Mo- tion by the Methods of Middle Elongation and Transits. The Balance, its Adjustments and Use, and the Calibration of a Set of Weights. The Planimeter, its Calibration and Use. Parallelogram of Forces. Parallel Forces. The Principle of Moments. Coefficient of Friction. Wheel and Axle. Efficiency of a System of Pulleys. The Differential Pulley. Atwood's Machine. Determination of Gravity from Motion of a Freely Falling Body. Angular Acceleration, Angular Velocity, and Rotational Inertia. General Statement concerning Moment of Inertia and Simple Harmonic Motion. Gravity by the Physical Pendulum. Gravity by Kater's Pendulum. Variation of the Period of a Bar Pendulum with Position of Knife Edges. Young's Modulus by Stretching. Moment of Torsion and Slide Modulus. Young's Modulus by Flexure. Elastic and Inelastic Impact. | 352 |
| CHAPTER II | 115 |
| General Statements concerning Density. Specific Gravity Bottle. Den- sity with Correction for Temperature and Air Displacement. Nichol- son's Hydrometer. Fahrenheit's Hydrometer. Hare's Method of determining Density of a Liquid. Verification of Boyle's Law. Com- parison of Barometers. Variation of Pressure of Saturated Vapor with Temperature. | |
| CHAPTER III | 133 |
| General Statements concerning Calorimetry. Heat of Vaporization of Water. Heat of Fusion of Ice. Specific Heats of Solids and Liquids. Radiating and Absorbing Power of Surfaces. Electrical Method of determining Joule's Equivalent. Coefficient of Linear Expansion. Co- efficient of Volume Expansion of Liquids. | |
| CHAPTER IV | 158 |
| Radius of Curvature by Reflection. Focal Length of a Concave Mirror. Focal Length of a Convex Lens. Focal Length of a Concave Lens. Magnifying Power of a Telescope. Magnifying Power of a Microscope. | |

| | | |
|--------------|---|-----|
| | The Adjustments of a Spectrometer. Index of Refraction of a Prism. Calibration of a Prism. A Study of Flame Spectra. The Diffraction Grating and Measurement of Wave Lengths. | |
| CHAPTER V | General Statements concerning Photometry. Horizontal Distribution of Light by the Bunsen or Lummer-Brodhun Photometer. Variation of Candle Power with Voltage. Calibration and Use of the Weber Photometer. | 182 |
| CHAPTER VI | Measurement of Pitch by the Syren. Interference and Measurement of Wave Length by Koenig's Apparatus. Resonance of Columns of Air and the Velocity of Sound. Velocity of Sound in Brass. The Sonometer. Study of Transverse Vibrations of Cords by Melde's Method. | 192 |
| CHAPTER VII | General Statements concerning Static Electricity. Notes on Electric and Magnetic Potential. Electrostatic Induction. The Principle of the Condenser. The Holtz Machine. The Holtz Machine (<i>continued</i>). | 202 |
| CHAPTER VIII | General Statements concerning Magnetism. Lines of Force and Study of Magnetic Fields. Magnetic Moment by Method of Oscillations. Magnetic Moment by the Magnetometer. Measurement of the Intensity of a Magnetic Field. Distribution of "Free" Magnetism in a Permanent Magnet. | 219 |
| CHAPTER IX | General Statements concerning the Electric Current. Law of the Tangent Galvanometer. Law of the d'Arsonval Galvanometer. Measurement of Current by Electrolysis. Theory of Shunts. Measurement of the Constant of a Sensitive Galvanometer. Applications of the Galvanometer to the Measurement of Current. Calibration of an Ammeter. | 234 |
| CHAPTER X | General Statements concerning Difference of Potential and Electromotive Force. Ohm's and Kirchhoff's Laws. Ohm's Method for the Measurement of E. M. F. Fall of Potential in a Series Circuit. Potential Difference at the Terminals of a Battery. Fall of Potential in a Wire carrying a Current. Beetz's Method of measuring E. M. F. To trace the Lines of Equal Potential in a Liquid Conductor. Variation of the E. M. F. of a Thermo-element. Calibration of a Voltmeter. Comparison of Electromotive Forces by Poggendorf's Method and by Lord Rayleigh's Method. The Potentiometer. | 268 |
| CHAPTER XI | General Statements concerning Resistance. Measurement of Resistance by the Wheatstone Bridge. Calibration of a Slide Wire. Carey-Foster's Method of measuring Low Resistances. Measurement of Resistance by | 303 |

the Fall of Potential Method. Measurement of Specific Resistance. Temperature Coefficient for Resistance. Kelvin Double Bridge Method of measuring Low Resistances. Resistance of Electrolytes. Internal Resistance of a Battery by Ohm's, Thomson's, Mance's, Modified Mance's, Fall of Potential, and Benton's Methods. Resistance of a Galvanometer by Half Deflection, Equal Deflection, and Thomson's (Lord Kelvin's) Methods.

CHAPTER XII 337

General Statements concerning Electrical Quantity. Constant of a Ballistic Galvanometer. Logarithmic Decrement of a Galvanometer Needle. Comparison of the Capacities of Two Condensers. Measurement of Capacity in Absolute Measure.

CHAPTER XIII 352

General Statements concerning Induction. Dip and Intensity of the Earth's Magnetic Field. (Method of the Earth's Inductor.) Measurement of the Lines of Force of a Permanent Magnet. Mutual Induction. General Statements concerning Self-induction. Measurement of Self-induction by Comparison with a Variable Standard Self-induction, by Rimington's Modification of Maxwell's Method, and by Anderson's Method.

CHAPTER XIV 373

General Statements concerning the Magnetic Properties of Iron. Test of the Magnetic Properties of Iron by the Magnetometer Method, by the Ring Method using a Ballistic Galvanometer.

TABLES 392

Some Useful Numbers. Work and Power. Densities of Some Substances. Coefficients of Friction. Elastic Constants. Data on Change of State. Variation in Boiling Point of Water with Change in Barometric Pressure. Specific Heats and Coefficients of Expansion. Vapor Pressure of Saturated Vapor at Various Temperatures. Vapor Pressure and Relative Humidity. Index of Refraction for Sodium Light. Bright Line Spectra. Velocity of Sound. Specific Resistances and Temperature Coefficients. Electrochemical Equivalents. Specific Resistances of Electrolytes. Electromotive Force of Cells. Wire Gauge and Resistance of Copper Wire. Logarithms of Numbers. Natural Trigonometric Functions.

A LABORATORY MANUAL OF PHYSICS AND APPLIED ELECTRICITY.



VOLUME I.

JUNIOR COURSE IN GENERAL PHYSICS.

REVISED AND REWRITTEN BY ERNEST BLAKER.



INTRODUCTION.

THE object of all of the experiments described in the following pages is twofold: (1) to illustrate, and therefore impress more thoroughly on the mind, the principles and laws which have previously been taught by textbooks or lectures; (2) to familiarize the student with proper methods of observation and physical experimentation. These two aims should be kept in view throughout the work which follows.

GENERAL DIRECTIONS.

Before beginning any experimental work, the student is advised to read carefully the directions for the experiment that is to be performed, making sure that the object of the experiment and the means to be employed in accomplishing this object are fully understood. If the experiment involves principles which are unfamiliar, the matter should be looked up in some reference book before the observations are begun. On account of the large number of textbooks and other books of

reference and the ever increasing number, few references except to original sources are given in the manual. A very complete list of references to original articles on the topics treated in Electricity and Magnetism will be found at the ends of the appropriate chapters in Henderson's *Practical Electricity and Magnetism*. If this is done, the significance of each step in the experimental work will be appreciated, and the experiment will therefore be more instructive. The likelihood of essential observations being omitted is also less when the bearing of each observation upon the result is fully understood.

RECORD OF OBSERVATIONS. All original observations are to be entered in the regulation notebook at the time they are made.

The uniform observance of this rule will save annoyance from simple mistakes due to carelessness or haste, which are frequently made even by the best observers, and which, without the original observations, it would be impossible to correct.

It is a saving in the end to devote enough time to the original records to make them neat and clear, and so complete and logically arranged as to enable any person who is familiar with the experiment to understand the meaning of each figure recorded.

In all cases it is the *original* observations that are to be recorded. A derived result should in no case be recorded as an observation, no matter how simple may be the process of derivation.

For example, it may be required to find the duration of a certain phenomenon; let us say that it begins at half past three o'clock and lasts until twenty-two minutes of four; the time is eight minutes, but this is a derived result obtained by subtracting 3.30 from 3.38. The actual time of beginning and end should be recorded, and the subtraction performed afterward.

It is advised that formulas, proofs, the solution of problems, notes, and questions also be entered in the notebook. It will often be found convenient to have numerical work carried out

in the notebook. Always allow at least two pages for each experiment, the first page being a left-hand page. Put in sketches and diagrams of apparatus, and always put in *working diagrams* of all connections in electrical experiments.

Observations. — It is to be remembered that the object of scientific observations is not to confirm preconceived theories, or to obtain a series of results which shall arouse admiration on account of their uniformity, but to discover the truth in regard to the phenomenon investigated, no matter what the truth may be. It is of the greatest importance, therefore, that the observer should be entirely unprejudiced, either by a knowledge of the results of other experimenters, or by any preconceived notion as to what the results should be. It is not meant by this that the observer must be ignorant of the probable results; but that his observations should be taken with as much care as though he were ignorant, and that great precautions must be taken to avoid the almost unconscious tendency, to which all observers are more or less subject, of making observations correspond with what is thought to be true.

In many cases artificial devices can be used to insure unprejudiced observations. For example, the scale of a micrometer screw may be covered, so that it is kept out of sight until the setting is made. Or, in an experiment like that on the Coefficient of Friction (No. C₁) one experimenter may adjust the weights while the other observes whether the motion obtained is uniform. Since the latter does not set the weights, his judgment is uninfluenced by any assumption as to the law by which they vary.

In the measurement of almost all physical quantities the results will be better if the observation is repeated several times. The individual observations will doubtless differ from one another on account of slight unavoidable errors; but the mean of the results will in all probability be nearer the truth than any one observation. To gain the advantages of taking an average, however, it is necessary that each observation should be independent of all the rest. Knowing that all the measurements

should be alike except for accidental errors, there is an unconscious tendency to make them agree. This tendency must be carefully guarded against, as in the cases cited above. Each observation should be taken as carefully as though the final result depended upon it alone.

Estimation of Tenths. — In measurements in which a graduated scale of any kind is used it often happens that the result sought cannot be expressed by any exact number of scale divisions. For example, in using a thermometer graduated to single degrees the top of the mercury column will probably come between two divisions on the scale. In such cases always estimate the fractional part of a division by the eye, expressing the fraction in tenths. Even if the estimation is poor, it gives results nearer to the truth than if the fraction were disregarded; while after a little practice it will be found possible to estimate tenths with great accuracy.

Choice of Conditions. — It often happens that the accuracy of the results of an experiment can be improved by a proper choice of the conditions under which the observations are made. An example of this fact occurs in the experiment where the internal resistance of a cell is determined by measurements of the current sent by the cell through two different external resistances. If I_1 , R_1 , and I_2 , R_2 , represent the corresponding values of current and resistance, the internal resistance of the cell is

$$x = \frac{I_1 R_1 - I_2 R_2}{I_2 - I_1}.$$

It is evident that if I_1 and I_2 are nearly alike, a slight error in the measurement of either may cause a very large error in x . To make the results reliable it is therefore necessary to choose R_1 and R_2 so that the two values of the current shall differ widely. There are many cases similar to this, where an inspection of the formula by which the results are to be computed will suggest what conditions will make the influence of accidental errors as small as possible.

Computations. — In computing results every precaution should be used to avoid simple numerical mistakes. Mistakes due to careless adding or subtracting, to incorrect copying from one sheet to another, to the misplacing of a decimal point, etc., are a source of great annoyance, and unless care is used to avoid them they will appear with a frequency that is startling to one unaccustomed to computing. The best safeguard against mistakes is neatness and an orderly arrangement of the work. In many cases four or five place logarithms are a help, not so much on account of any saving of time, as because of the diminished liability of mistakes. Tables of squares, reciprocals, etc., can often be used to advantage. When a number of similar computations are to be made, the work should be done systematically and the results arranged in tabular form.

The slide rule is perhaps the most valuable aid in computation and is a great time saver. The division of its scales is based on logarithms. Since multiplication and division of numbers, using logarithms, are performed by adding and subtracting logarithms, the same operations are performed by means of a slide rule, by adding and subtracting lengths of scale which are proportional to the logarithms of the numbers treated. Great care should be used in the use of the slide rule. With a little practice great proficiency in its use is attained, and an accuracy of from one to five tenths of one per cent can be assumed. This means that computations are correct to three significant figures, and sometimes the fourth may be estimated in that part of the scale where the graduation is coarsest. The slide rule is especially valuable where one number is to be multiplied by a series of numbers; as, for example, the multiplication of a galvanometer constant by the tangents of angles of deflections, in finding currents as measured by a tangent galvanometer. In this case one setting of the slide, or at most two, is necessary, and results may be readily read off the settings of the indicator. Do not use the slide rule when the method of least squares is involved.

In working up the results of an experiment time is often wasted by carrying the results to a degree of refinement that is not warranted by the observations upon which the computations are based. Very few of the experiments that are described here will give results that are accurate to within less than one tenth of one per cent. In most cases, therefore, it is useless to express the result by more than three, or at most four, significant figures. If it is decided from an inspection of the observations that the result should be carried to three places, then the computations should be made with four places in order to insure the accuracy of the last significant figure of the result. In the progress of the work numbers may be obtained in which five or six significant figures appear; in such cases all beyond the fourth may be discarded. The slide rule will automatically do away with the undesirable figures. Zeros must often be used as significant figures. For example, suppose a certain mass is twenty-five grams to within a tenth of a milligram. The following number indicates such an accuracy: 25.000. If the mass be known only to tenths of a gram, it would be written 25.0. If a certain computation involves a magnitude of thirteen places to the left of the decimal point, as in Young's Modulus for steel, it is neither to be written as 2,173,890,604,514 nor 2,170,000,000,000, but as 21.7×10^{11} . The result written as indicated in the last number shows that the significant figures are three, and that the third one, to the right of the decimal point, is in doubt. It requires the complete expression to indicate the magnitude of the result. This method of writing the result of computation has the merit of brevity, but its greatest usefulness is in indicating the accuracy of the work. It is often convenient to represent such quantities as that representing the electro-chemical equivalent of copper, not as 0.000328 but as 328×10^{-6} .

In many cases approximate methods may be used which will effect a considerable saving in time without diminishing the accuracy of the results. For example, it often happens that a factor

of the form $\frac{1}{1+k}$ appears as a multiplier, k being a very small quantity. In most cases it is sufficiently accurate to say that

$$\frac{1}{1+k} = 1 - k;$$

and in general

$$(1+k)^n = 1 + nk, \text{ when } k \text{ is small.}^*$$

When the angle θ is small, it is often convenient to make the following approximations :

For $\sin \theta$, the angle θ in radians,
for $\tan \theta$, the angle θ in radians,
and for $\cos \theta$, 1.

Units. — In almost all physical measurements the units employed are based upon the centimeter-gram-second system. Since this system differs in several important particulars from that generally used in engineering work, it is essential that these differences should be clearly understood.

In physics all derived units are defined in terms of the fundamental units of length, *mass*, and time. In the foot-pound-second system, commonly employed in engineering work, the fundamental units are length, *weight*, and time. Now the terms "weight" and "mass," although technically quite different in meaning, are frequently confused in ordinary conversation, and it is probably from this cause that the relation between the two systems is so often misunderstood.

It must be remembered that the weight of a body is defined as the force with which the body is pulled downward by gravity. By the word *pound* is meant, not the block of metal which weighs a pound, but the force by which that block is drawn toward the center of the earth. Since a force is numerically equal to the product of the mass moved into the acceleration, we have

* Other examples of the use of approximations will be found in Kohlrausch, in Stewart and Gee, Appendix to vol. 1, and in Watson's Practical Physics.

$W = Mg$, and in order to find the mass of a body whose weight in pounds is known, we must divide the weight by g ; *i.e.*

$$M = \frac{W}{g}.$$

The mass of a pound weight is therefore $\frac{1}{32.2}$, and the unit of mass in the foot-pound-second system is the mass of a body which weighs 32.2 lbs.

In the *C. G. S.* system the gram is the unit of *mass*. By the word *gram*, therefore, is meant the amount of matter contained in a certain standard piece of metal. The weight of this piece of metal is found by multiplying its mass by the acceleration of gravity, and for the latitude of Ithaca (about 40°) is a little more than 980 dynes.

The process of weighing a body by means of a balance consists in choosing the weights so that both scale pans are pulled downward by gravity with the same force. When the adjustment is correct, the weight is therefore the same on each pan. But since, so long as g remains unaltered, the mass of a body is proportional to its weight, the two masses must also be equal. The balance may therefore be used either for comparing weights or for comparing masses. In physical experiments the weight is seldom required, so that the balance is used almost entirely for the measurement of mass. The standards used, being grams or multiples of a gram, are standards of mass, and the term "weights," which is so commonly applied to them, is really a misnomer.

If it is found, therefore, in making a weighing by the balance that 100 grams are required to produce equilibrium, the mass of the body weighed is shown to be 100 grams. The *weight* of the body is $100 \times g = 98,000$ dynes.

If care is used in distinguishing between the terms "weight" and "mass," no difficulty should be experienced in passing from one system of units to the other. The two systems are perfectly consistent with each other when properly used, and each

has special advantages for the kind of work in which it is commonly employed.

Graphical Representation of Results.—When a series of observations has been taken to show the manner in which one quantity depends upon another, it is often of advantage to present a summary of the results to the eye by means of a curve. Points upon such a curve are located on cross-section paper by using the values of one quantity as abscissas, and the corresponding values of the other quantity as ordinates, the scales used in measuring the various co-ordinates being any that are convenient. It is customary to use the values of the independent variable as abscissas.

As an example of the use of the graphical method, we may consider the experiment on the coefficient of Friction (C_1). In this experiment

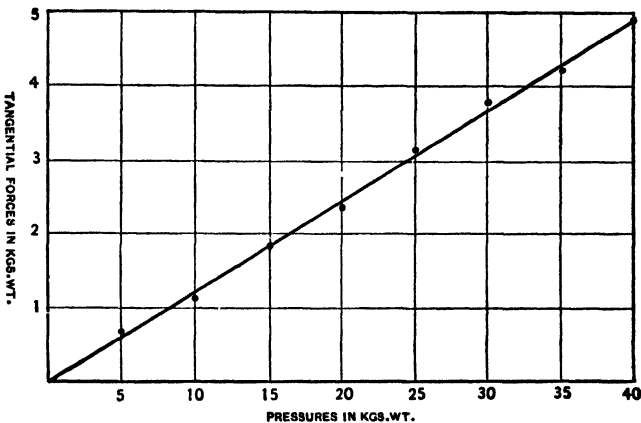

Fig. 1.

the force necessary to overcome the moving friction between two surfaces is measured for a number of different values of the pressure between the two. It is natural to suppose that the amount of friction depends in some way upon the pressure. To determine the law of this dependence, a curve is plotted, in which pressures are used as abscissas, and the corresponding values of the tangential forces to overcome friction as

ordinates. If the observations have been carefully taken, the points located in this way will be found to lie very nearly upon a straight line passing through the origin. If the divergence from a straight line is not great, it is proper to assume that such divergence in the case of individual points is due to the accidental errors of observation, and that a straight line passing as nearly as possible through all the points really represents the relation sought. Since the line is straight, it shows that there is a constant relation between the various normal pressures and their corresponding moving forces. The slope of the line with respect to the axis of abscissas, *i.e.* the tangent of the angle it makes with the x axis, is constant and is equal to the moving force divided by the normal pressure. But the moving force divided by the normal pressure gives the value of the coefficient of friction. Thus the slope of the line, *in terms of the scale used*, gives the coefficient of friction sought. Such a curve not only shows at once the relation between the quantities plotted, but also makes it possible to get the mean value of the coefficient of friction from the curve.

It is to be observed that when a curve is plotted in order to show the relation between two variables, it is by no means necessary that the horizontal and the vertical scale should be the same. Either scale may be assumed at pleasure, and without reference to the other.

In the case just cited, for example, the horizontal scale may be taken as 5 kilograms to the inch, while the vertical scale may be 1 kilogram, $\frac{1}{10}$ kilogram, or any other quantity that proves convenient. In taking readings from the curve, however, regard must be paid to the scale employed. If, for example, the horizontal scale adopted is 5 kilograms to the inch, 5 inches would be read 25 kilograms. If the vertical scale at the same time is $\frac{1}{10}$ kilogram to the inch, 5 inches on the vertical scale would be read 1 kilogram.

The equation of a straight line passing through the origin is $y = mx$, in which m is a constant. But the x 's of the line represent pressures, while the y 's represent the corresponding values of the moving force. The law established by the experiment is therefore that $F = mP$; *i.e.* friction is proportional to pressure.

But $\frac{F}{P} = m$, and m gives the value of the coefficient of friction μ . Therefore, substituting μ for m gives

$$F = \mu P, \quad (1)$$

which is the *physical equation* of the curve, *i.e.* the equation of the curve in terms of the physical quantities used.

The example referred to above, where the curve obtained is a straight line passing through the origin, illustrates the simplest case that could arise. Suppose that the normal pressure be made up of two parts, a known variable part and an unknown but constant part. If in this case the known variable parts of the normal pressure be plotted as abscissas and the corresponding moving forces as ordinates, the resultant curve will be a straight line, but will not pass through the origin. The slope of the line will give the coefficient of friction as before, as will be shown in the following discussion. Let the constant unknown pressure be denoted by P_0 , and P , F , and μ represent the known part of the pressure, the moving force, and the coefficient of friction, respectively.

Then

$$\mu = \frac{F}{P + P_0}$$

or

$$F = \mu P + \mu P_0, \quad (2)$$

which is the *physical equation* of the straight line, in which μ is the slope of the line, μP_0 the intercept on the y axis, and P_0 the negative intercept on the x axis. Thus it is possible to find the constant unknown pressure from the curve. It should be noted that in finding the slope of such a curve it is necessary to divide the value of any ordinate by the corresponding abscissa *plus* the negative intercept, or to use the expression

$$\frac{y_2 - y_1}{x_2 - x_1} = m. \quad (3)$$

The cases above outlined should be understood thoroughly, for the principles there given will be found to have wide application.

Many times it is found from the physical theory that the form the curve will take will be hyperbolic, parabolic, or exponential. It is well to plot such curve, develop its physical equation, and get such physical constants from it as are possible

The intercepts, the slope, asymptotes, area, maxima, and minima should be fully interpreted.

Since the straight line is the curve which is most readily tested, it is often convenient to transform the results of an experiment in such a way that they will give a straight line when plotted.

Suppose, for example, that the volume of a gas has been measured when subjected to a number of different pressures. We know from Boyle's law that $PV = \text{a constant} = k$. If the results were plotted, therefore, with pressures and corresponding volumes for co-ordinates, the resulting curve would be a hyperbola whose equation is $xy = k$. If, however, we plot instead of volumes the products PV , the curve will be a straight line with the equation $y = k$. By observing whether this line is accurately straight, the law can be tested more readily than if the first curve had been used, while if the line is not straight, it affords a simple means of exhibiting the deviation from Boyle's law to the eye.

If the method described in Exp. H₁ for verifying Boyle's law is employed, the data may be plotted in still a different way to advantage. In this method the total volume V is not measured, but merely a portion v , while a part v_0 of the volume remains unknown, but constant.

$$\begin{aligned} \text{Then} \quad V &= (v + v_0), & (4) \\ PV &= P(v + v_0) = k. & (5) \end{aligned}$$

If now P and V are taken as co-ordinates, a hyperbola should be obtained. But if v and $\frac{1}{P}$ are used, the resulting line should be straight, its equation being

$$\frac{1}{P} = \frac{v}{k} + \frac{v_0}{k}. \quad (6)$$

If the data are plotted in this way, a means is therefore afforded of determining both v_0 and k . Since the line obtained is straight, we know that the form of its equation must be

$$y = mx + b, \quad (7)$$

and the numerical values of m and b can be at once computed.

Since these two equations represent the same line, we must have

$$\frac{1}{k} = m, \text{ and } \frac{v_0}{k} = b. \quad (8)$$

1. Errors of method.
2. Inaccuracies in instruments.
3. Accidental errors of observation.
4. Mistakes.

The avoidance of errors due to the employment of faulty methods is largely a matter of judgment and experience on the part of the experimenter. No general rule can be given. Probably the best means of testing for the presence of errors in the method of measurement employed is to repeat the determination by several radically different methods. If the results agree, it is to be presumed that the methods contain no fundamental errors.

The presence of inaccuracies in the instruments used may similarly be tested by making the same measurement with several different instruments. Special methods may also in most cases be devised by which the errors of any given instrument may be determined. These methods are different for each particular case, so that it is useless to give illustrations here.

After the errors of method and of apparatus are as far as possible eliminated, there still remain the "accidental errors of observation." Two measurements of the same quantity made by the same observer, with the same instrument, and to all appearances under the same conditions, will, in the great majority of cases, differ from each other by an appreciable amount. Such discrepancies are entirely accidental, and a cause for the disagreement in the two results can in no case be assigned. The discussion of these errors can therefore only be undertaken with the aid of the theory of probabilities, and numerous treatises have in fact been written which deal with the "theory of errors" and the "method of least squares."*

* For brief discussions see Kohlrausch, *Physical Measurements*, and the appendix to Stewart and Gee, vol. 1. For more complete discussions see Merriman, *Method of Least Squares*; Violle, *Cours de Physique* (see Introduction to vol. 1); Weinstein, *Handbuch der Physikalischen Maassbestimmungen*, vol. 1; and Holman's *Precision of Physical Measurements*.

The principal results of such discussion, in so far as they have an application to physical measurements, will be briefly stated here.

Probable Error, etc.—If a large number of *independent** measurements of the same quantity are made, it is evident that one result is as likely to be correct as any other. As a matter of fact, all of the results are doubtless in error. It is also evident that the *most probable* value of the result sought will be found by taking the average of all the values found. This average will probably be more correct than any one of the single determinations. For this reason it is always advisable to repeat a determination a number of times when the conditions are such as to make this possible.

If a series of independent observations has been taken under favorable conditions and by a skillful observer, so that the individual results do not differ greatly from one another, it is obvious that the average has greater probable accuracy than if the conditions had been unfavorable, so that the individual results showed a wide divergence among themselves. From an inspection of a series of determinations we may therefore form an estimate of the probable accuracy of the average. In order to express this estimate numerically the term "probable error" has been introduced, which is defined as follows:

The *probable error* of a result is a quantity e such that the probability that the actual error is *greater* than e is the same as the probability that the actual error is *less* than e .†

A result whose probable error is small is thus in all probability more accurate than one whose probable error is large.

The probable reliability of a result is often indicated by writing the probable error with the sign \pm after the result itself: e.g. $l = 27.36 \pm 0.21$.

* Too much stress cannot be laid on the condition that the observations must be *independent*; i.e. the observer must be entirely uninfluenced by results previously obtained, or by his own opinion as to what the result "ought" to be. The avoidance of this bias in making a series of readings of the same quantity is one of the most difficult things which an observer has to learn.

† The name "probable error" is an unfortunate one and is apt to lead to confusion. That the probable error of a result is e does *not* mean that the result is probably in error by this amount.

If another series of measurements of the same quantity gave the result $l = 27.51 \pm 0.38$, it is clear that the first result is more reliable.

If a series of observations $a_1, a_2, \dots a_n$ has been taken, of which the average is a , then $a - a_1, a - a_2, \dots a - a_n$ are called the *errors*. If the sum of the squares of the errors be divided by the number of observations less one, the result is the *square* of the mean error. The *probable error of a single observation* * is found by multiplying the square root of the square of the mean error by 0.67449 (for ordinary work use 0.674) and prefixing the sign \pm as follows:

$$e' = \pm 0.674 \sqrt{\frac{(a - a_1)^2 + (a - a_2)^2 + \dots + (a - a_n)^2}{n - 1}}. \quad (11)$$

The *probable error of the mean* is found by the use of the following equation:

$$e = \pm 0.674 \sqrt{\frac{(a - a_1)^2 + (a - a_2)^2 + \dots + (a - a_n)^2}{n(n - 1)}}. \quad (12)$$

As an example of the computation of the probable error we may consider the following case where ten independent settings are made with a spherometer on the same surface. (See Exp. A₁.)

| Readings on Disk | Deviations from Mean $a - a_1$, etc. | Square of Deviations d^2 |
|------------------|--|-------------------------------|
| 44.5 | - 0.1 | 0.01 |
| 44.8 | + 0.2 | 0.04 |
| 44.2 | - 0.4 | 0.16 |
| 45.0 | + 0.4 | 0.16 |
| 45.1 | + 0.5 | 0.25 |
| 44.4 | - 0.2 | 0.04 |
| 44.6 | ± 0.0 | 0.00 |
| 44.2 | - 0.4 | 0.16 |
| 44.5 | - 0.1 | 0.01 |
| 44.7 | + 0.1 | 0.01 |
| Mean 44.6 | Mean 0.24 | $\Sigma d^2 = 0.84$ |

Probable error of a single observation $e' = \pm 0.204$.

Probable error of the mean $e = \pm 0.065$.

* For the derivation of this formula, see any textbook of least squares.

It is to be observed that the computation of the probable error has no significance unless n is large. Unless at least *ten* observations have been taken, it is useless to compute e .

On account of the annoyance in computing the probable error, the "average deviation" is often used instead; *i.e.* the average (disregarding signs) of the deviations of the individual observations from the mean.

It is to be observed that the probable error affords no means of estimating the so-called "constant errors" that are caused by improper methods of measurement or by imperfections in the instruments used. These may be very large even when the "probable error" is quite small. The use of the "probable error" may be looked upon as merely an arbitrary means of showing at a glance how closely the individual observations have agreed among themselves, and it indicates, therefore, to what extent the accidental errors of observations have been eliminated.

Assignment of Weights in Taking an Average.—When the same quantity has been measured by several different methods, the results will in general differ, and it is often desirable to combine all the results by taking an average. In such cases "weights" should be assigned to the different determinations in accordance with their probable accuracy. The theory of probabilities shows that in taking an average each quantity should be given a weight equal to the reciprocal of the square of its probable error; *i.e.* if the various values determined by the different methods are $A_1, A_2, A_3,$ etc., the probable errors being, respectively, $e_1, e_2, e_3,$ etc., the most probable value of the quantity in question, as determined from *all* of the observations, is

$$A = \frac{\frac{1}{e_1^2}A_1 + \frac{1}{e_2^2}A_2 + \dots}{\frac{1}{e_1^2} + \frac{1}{e_2^2} + \dots} \quad (13)$$

In Exp. A₁, for example, the length l of one side of the triangle formed by the three legs of the spherometer may be determined in several different ways. Let the result obtained by one method be $l = 6.12^{\text{cm}} \pm 0.03$, while that determined by

another and less accurate method is $l = 6.20^{\text{cm}} \pm 0.11$. It is certainly not right to use the average $\frac{6.12 + 6.20}{2} (= 6.16)$, for much more reliance can be placed on the first result than on the second. According to the rule above stated the most probable value of l is

$$l = \frac{\frac{1}{(0.03)^2} 6.12 + \frac{1}{(0.11)^2} 6.20}{\frac{1}{(0.03)^2} + \frac{1}{(0.11)^2}} = 6.126. \quad (14)$$

Influence of the Errors of Observation upon Derived Results. —

It often happens that the final result sought must be computed from the observations themselves by substitution in some formula. In such cases it is of importance to know how the final result will be influenced by possible errors in the individual observations. If an error in one of the quantities involved will produce a large error in the result, then this quantity must be observed with especial care. On the other hand, if an error in another of the observed quantities has only a slight influence on the result, it is needless to occupy one's time in measuring this quantity with a high degree of refinement. By considering this question before the actual measurements are begun, it is thus possible not only to obtain better final results, but also to save time in the observations themselves.

The general case may be discussed as follows: Let the result R , which is sought, be some function ϕ of the quantities to be observed;

$$i.e. \quad R = \phi(x, y, z, \dots).$$

Now if x, y, z , etc., are measured with absolute accuracy, R will be correct. But if one of the quantities x is in error by the amount e , then an error E_x will be introduced into the result, and

$$R' = R + E_x = \phi(x + e_1, y, z, \dots)$$

$$\text{from which} \quad E_x = \phi(x + e_1, y, z, \dots) - \phi(x, y, z, \dots). \quad (15)$$

Since e will in general be quite small in comparison with x , no great inaccuracy will be introduced by treating it as an

infinitesimal; *i.e.* neglecting powers higher than the first. Let it be supposed that

$$R = ax^2 + by - z. \quad (16)$$

But x is in error by an amount e ;

$$\begin{aligned} \text{then} \quad R' = R + E_x &= a(x + e)^2 + by - z \\ &= ax^2 + 2axe + ae^2 + by - z. \end{aligned}$$

Substituting for R its value in equation 16 and remembering that terms in e^2 may be neglected as infinitesimals of a higher order, it follows that

$$E_x = 2axe. \quad (17)$$

Now this same result might have been attained by finding the rate of change of R with respect to x ; that is, differentiating equation 16 with respect to x and multiplying by the error in x .

Returning to the general case we may, therefore, write

$$E_x = e_1 \frac{d}{dx} \phi(x, y, z, \dots).$$

$$\text{Similarly,} \quad E_y = e_2 \frac{d}{dy} \phi(x, y, z, \dots), \quad (18)$$

$$E_z = e_3 \frac{d}{dz} \phi(x, y, z, \dots),$$

etc.

If the probable errors e_1, e_2 , etc., are known, the corresponding errors E_x, E_y , etc., in the result may thus be readily computed. The probable error in the result due to the combined effect of the errors in all of the observed quantities may then be shown to be *

$$E = \sqrt{E_x^2 + E_y^2 + \dots}. \quad (19)$$

Take, for example, the case which occurs in Exp. A₁. The radius of curvature is given by the formula

$$r = \frac{l^2}{6a} + \frac{a}{2}. \quad (20)$$

Let us suppose that $l = 7.14 \pm 0.05$, and $a = 0.423 \pm 0.004$. Substituting in the formula $l = 7.14$ and $a = 0.423$, we obtain

$$r = 20.09.$$

* See Merriman's Method of Least Squares, etc.

To compute E_a and E_l , we have :

$$E_a = e_a \frac{d}{da} \phi(a, l) = e_a \frac{d}{da} \left[\frac{l^2}{6a} + \frac{a}{2} \right] \quad (21)$$

$$= e_a \left[-\frac{l^2}{6a^2} + \frac{1}{2} \right] = 0.004 \left[-\frac{71.4^2}{6 \times 0.423^2} + \frac{1}{2} \right] = -0.188.$$

$$E_l = e_l \frac{d}{dl} \phi(a, l) = e_l \frac{d}{dl} \left(\frac{l^2}{6a} + \frac{a}{2} \right) \quad (22)$$

$$= e_l \frac{l}{3a} = 0.05 \times \frac{7.14}{3 \times 0.423} = 0.28.$$

$$E = \sqrt{0.188^2 + 0.28^2} = 0.34. \quad (23)$$

$$\therefore r = 20.09 \pm 0.34.$$

When the formula is known by means of which the result of an experiment is to be computed, it is often possible to determine the most favorable conditions before beginning the observations. The method of procedure in such cases can best be explained by means of the following example : *

A tangent galvanometer is to be used in measuring a current. What are the most favorable conditions for making the measurement ?

The formula for computing the result is :

$$I = I_0 \tan \theta. \quad (24)$$

The only observed quantity is θ ; and if this angle is read from a circular scale, it is subject to the same error, e , no matter from what part of the scale it may be read. Let the resulting error in I be E .

$$\text{Then} \quad E = e \frac{d}{d\theta} \cdot I_0 \tan \theta = \frac{e I_0}{\cos^2 \theta}. \quad (25)$$

The *relative error* is

$$E' = \frac{E}{I} = \frac{e I_0}{\cos^2 \theta} \div I_0 \tan \theta = e \frac{1}{\sin \theta \cos \theta} = \frac{2e}{\sin 2\theta}. \quad (26)$$

It is, however, evident that E' reaches its smallest value when $\sin 2\theta$ reaches its greatest value, namely, unity. In other words, the relative error in the result will be least when the deflection of the galvanometer is 45° . If the galvanometer used has several coils, these should therefore always be so connected as to make the deflection as near 45° as possible.

* Numerous instructive examples will be found discussed in detail in Holman's *Discussions of the Precision of Physical Measurements*.

Determination of Constants by the Method of Least Squares.

— It often happens that a series of observations is made, not of the same quantity, but of quantities which are known to be related to one another. If the form of the equation expressing this relation is known (as is usually the case), the question then arises as to what values should be given to the constants of the equation in order that it should represent the results of experiment as accurately as possible.

A case of this kind is illustrated by Exp. C₂, where a series of observations is made to determine the relation between “working force” and “load” in the case of a wheel and axle. If the results are plotted, the points corresponding to the different observations will probably be found to lie nearly in a straight line, as shown in Fig. 2. Although it is impos-

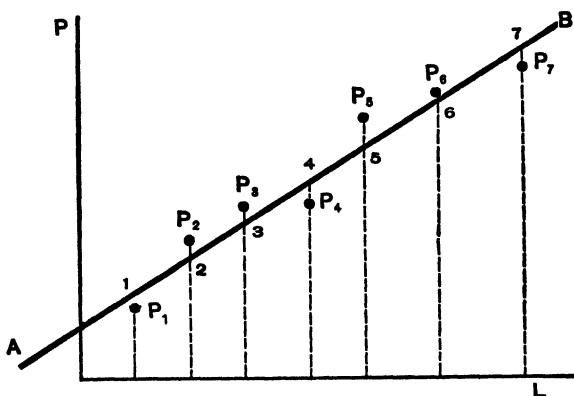

Fig. 2.

sible to draw a straight line which shall pass through all the observed points, yet it seems probable that these points would have formed a straight line, had it not been for accidental errors of observation. The problem, therefore, is to draw a straight line which shall pass as nearly as possible through all the points. This can often be done by the eye; but when the highest degree of accuracy is required, the Method of Least Squares should be used as explained below.

The method of procedure in all such cases rests upon the principle * that the results will best be represented by the equa-

* For the proof of this principle see any textbook of Least Squares.

tion in question when the constants are so chosen that the sum of the squares of the deviations of the individual observations from the values computed from the equation is a minimum.

In the example just cited, the formula which expresses the relation between "working force" (y) and "load" (x) is evidently

$$y = ax + b; \quad (27)$$

for the observations, when plotted, have been found to give roughly a straight line, and the general equation of a straight line is of the form stated. As the result of experiment a number of values y_1, y_2, y_3 , etc., of the force have been observed, corresponding respectively to loads of x_1, x_2, x_3 , etc. Now, if the constants a and b were known, it would be possible to compute y from x : *e.g.*

$$\begin{aligned} y_1' &= ax_1 + b, \\ y_2' &= ax_2 + b, \\ &\text{etc.} \end{aligned} \quad (28)$$

[The y 's have been primed in order to distinguish them from the observed values y_1, y_2 , etc.]

The principle of least squares, which has been stated above, now says that a and b must have such values that the sum

$$(y_1 - y_1')^2 + (y_2 - y_2')^2 + \dots$$

shall be a minimum.

Interpreted graphically, this means that the line must be so drawn that the sum of the squares of the distances 1 P_1 , 2 P_2 , etc., shall be as small as possible. (See Fig. 2.)

To determine a and b , it is therefore merely necessary to apply the ordinary methods for maxima and minima :

$$(y_1 - y_1')^2 + (y_2 - y_2')^2 + \dots = \Sigma(y - y')^2 = \text{a minimum.}$$

$$\text{But} \quad y' = ax + b.$$

$$\begin{aligned} \therefore (y_1 - ax_1 - b)^2 + (y_2 - ax_2 - b)^2 + \dots &= \Sigma(y - ax - b)^2 \\ &= \text{a minimum.} \end{aligned}$$

It is to be observed that x_1y_1, x_2y_2 , etc., are not variables, but constants, being the quantities determined by observation.

It is a and b that must be varied *until* such values are found that the above expression is a minimum.*

The conditions are therefore that

$$\frac{d}{da} \Sigma(y - ax - b)^2 = 0 \text{ and } \frac{d}{db} \cdot \Sigma(y - ax - b)^2 = 0. \quad (29)$$

On performing the differentiation the following equations result:

$$\begin{aligned} -2(y_1 - ax_1 - b)x_1 - 2(y_2 - ax_2 - b)x_2 - \dots \\ = -2 \Sigma(y - ax - b)x = 0, \\ -2(y_1 - ax_1 - b) - 2(y_2 - ax_2 - b) - \dots \\ = -2 \Sigma(y - ax - b) = 0. \end{aligned} \quad (30)$$

These equations may be more readily utilized if written in the following form: †

$$\begin{aligned} \Sigma xy - a \Sigma x^2 - b \Sigma x = 0, \\ \Sigma y - a \Sigma x - bn = 0. \end{aligned} \quad (31)$$

In the last equation n represents the number of observations.

Since the quantities Σxy , Σx^2 , etc., are readily computed from the observations, these two equations make possible the determination of both a and b . In fact,

$$a = \frac{\Sigma x \Sigma y - n \Sigma xy}{(\Sigma x)^2 - n \Sigma x^2}, \quad (32)$$

and

$$b = \frac{\Sigma x \Sigma xy - \Sigma y \Sigma x^2}{(\Sigma x)^2 - n \Sigma x^2}.$$

* Note that this variation of a and b in the algebraic work corresponds to shifting the line AB in the graphical consideration of the problem. In the one case a and b are varied until certain mathematical considerations indicate that $\Sigma(y - y')^2$ has reached a minimum; in the other case the line is shifted until it looks to the eye as though a good intermediate position had been reached.

† The student is cautioned in regard to the use of the sign of summation. Σxy means $x_1 y_1 + x_2 y_2 + \dots$, while $\Sigma y = y_1 + y_2 + y_3 + \dots$. Σxy is therefore *not* equal to $\Sigma x \Sigma y$.

In the general case, where the relation between x and y is expressed by an equation of any form, the method of procedure is the same as that illustrated by the example above.

$$\text{Let } y = \phi(x, a, b, c, \dots),$$

where a, b, c , etc., are the constants to be determined.

The observed values of y are then y_1, y_2, y_3 , etc., while the computed values are y_1', y_2' , etc. The principle of least squares requires that the sum

$$\begin{aligned} & (y_1 - y_1')^2 + (y_2 - y_2')^2 + \dots \text{ shall be a minimum;} \\ \text{i.e. } & [y_1 - \phi(x_1, a, b, c, \dots)]^2 + [y_2 - \phi(x_2, a, b, c, \dots)]^2 + \dots \\ & = \Sigma [y - \phi(x, a, b, c, \dots)]^2 = \text{a minimum.} \\ & \therefore \frac{d}{da} \Sigma [y - \phi(\)]^2 = 0, \\ & \frac{d}{db} \Sigma [y - \phi(\)]^2 = 0, \tag{33} \\ & \frac{d}{dc} \Sigma [y - \phi(\)]^2 = 0, \\ & \text{etc.} \end{aligned}$$

The number of equations obtained in this way is always equal to the number of constants sought, so that the problem is in all cases determinate.

In applying the method of least squares, the numerical work is always somewhat tedious, especially when the number of observations is large. For this reason the computations should be made with especial care; for if a mistake occurs, considerable difficulty will be met with in discovering it. The following example illustrates a systematic way of arranging the computations, which will be found of advantage:

Equation is known to be of the form $y = ax + b$.

$$\begin{aligned} \therefore a &= \frac{\Sigma x \Sigma y - n \Sigma xy}{(\Sigma x)^2 - n \Sigma x^2}, \\ b &= \frac{\Sigma x \Sigma xy - \Sigma y \Sigma x^2}{(\Sigma x)^2 - n \Sigma x^2}. \tag{34} \end{aligned}$$

| x | y | xy | x^2 |
|-----|------|-------|-------|
| 5 | 0.20 | 1.00 | 25 |
| 10 | 0.34 | 3.40 | 100 |
| 15 | 0.48 | 7.20 | 225 |
| 20 | 0.64 | 12.80 | 400 |
| 25 | 0.80 | 20.00 | 625 |
| 30 | 0.93 | 27.90 | 900 |
| 35 | 1.10 | 38.50 | 1225 |
| 40 | 1.24 | 49.60 | 1600 |
| 45 | 1.38 | 62.10 | 2025 |
| 50 | 1.54 | 77.00 | 2500 |
| 275 | 8.65 | 299.5 | 9625 |

$$\begin{aligned}\therefore \Sigma x &= 275 \\ \Sigma y &= 8.65 \\ \Sigma xy &= 299.5 \\ \Sigma x^2 &= 9625\end{aligned}$$

$$a = \frac{275 \times 8.65 - 10 \times 299.5}{275^2 - 10 \times 9625} = 0.299,$$

$$b = \frac{275 \times 299.5 - 8.65 \times 9625}{275^2 - 10 \times 9625} = 0.433.$$

The equation which most accurately represents the relation between the quantities measured is therefore

$$y = 0.299x + 0.433.$$

A simple means of detecting large mistakes in computation is always afforded by plotting the curve represented by the equation found by least squares upon the same diagram as the original data. This curve should then pass close to all of the observed points, although it may not actually pass through any one of them.

CHAPTER I.

GROUP A: LENGTH, TIME, AND MASS.

- (A₁) *Curvature of a lens* ; (A₂) *Calibration of a thermometer tube* ;
(A₄) *Volumes and densities by measurement* ; (A₅) *Time of periodic motion* ; (A₆) *The balance and its use* ; (A₇) *The planimeter*.

EXPERIMENT A₁. Measurement of the curvature of a lens by means of the spherometer.

The spherometer, as indicated by its name, is intended primarily for the determination of the radius of a spherical surface. It can also be employed, however, for other measurements: for example, the thickness of plates of glass or other materials can be determined by means of the spherometer, although unless the plates are almost perfectly plane, the results will not possess a high degree of accuracy.

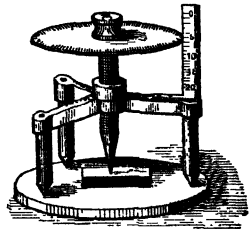

Fig. 3. — The Spherometer.

As will be seen by reference to Fig. 3, which represents a simple type of spherometer, the instrument consists essentially of four metallic rods connected in the manner shown, each rod being sharply pointed at the lower end. Three of these rods are fixed in position, and constitute a tripod upon which the instrument rests. The three supporting points are made to form an equilateral triangle. The fourth rod may be moved in a direction at right angles to the plane of this triangle by means of a micrometer screw. It is situated equidistant from the other legs of the instrument.

In using the spherometer to determine the curvature of a

surface (see Fig. 4) which is known to be spherical, such for example as that of a lens, the reading of the micrometer is taken,

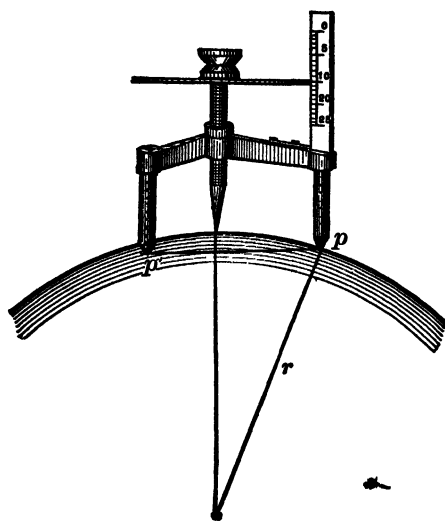

Fig. 4.

first when the instrument rests upon a plane surface, and then when it is placed upon the lens in question. All four points must in each case be in contact with the surface. The difference between the two micrometer readings then gives the height of the fourth point above the plane of the other three. If this height be represented by a , and the length of one side of the triangle formed by the three fixed points by l ($l = \overline{pp'}$; Fig. 4), then the radius of curvature is readily shown to be *

$$r = \frac{l^2}{6a} + \frac{a}{2}. \quad (35)$$

Since a , which enters the formula for r , is in general a very small quantity, its value must be determined with especial care. It is therefore advisable to make a number of independent settings of the micrometer, and to use the mean of the readings obtained. Make at least ten disk readings for the plane surface, and the same number for the spherical surface.

In order to avoid errors due to the fact that the disk is not plane or is not perpendicular to the axis of the screw, it is well to count the number of complete turns, and use disk readings for the fraction of a revolution; then, knowing the pitch of the screw, compute a . Be careful to tabulate *actual readings*.

* For a more detailed description of the spherometer and derivation of this formula, see Stewart and Gee, vol. 1.

In making a series of readings with the spherometer upon the same surface, it is best not to look at the scale until the setting has been made. Otherwise it is difficult to avoid being influenced by a knowledge of previous readings. Each reading should be the result of an independent attempt to obtain an exact setting.

In determining l , two methods may be employed; viz. (1) the three sides of the triangle may be measured directly by a millimeter scale; (2) the instrument may be placed upon a piece of paper, and the distances between the impressions left by the feet may be measured. After making a number of measurements by both methods, obtain the mean and compute r .

After the value of r has been computed, determine the influence upon the result of the probable error in measuring the vertical height; also the influence of the error which is likely to occur in measuring the distance between the legs; and finally the probable error in the result, arising from both these causes.

Computation of Probable Errors.

From the disk readings taken on the plane surface compute the "probable error of the mean" and the "probable error of a single observation" in disk divisions. (See pp. 18 and 19.)

Treat the readings on the lens surface in a similar manner.

From the "probable error of the mean" of the readings on the plane surface and the "probable error of the mean" of the readings on the spherical surface, compute the probable error of a in scale divisions. Knowing the pitch of the screw, reduce the probable error to centimeters. In this case, a is the derived result sought and the general equation

$$R = \phi(x, y, z) \quad (\text{See pp. 21 and 22.})$$

becomes $R = (x - y)$.

Estimate the error which is likely to occur in measuring l . In many cases of direct measurement probable error has little or no meaning. It is not at all difficult to estimate the degree of accuracy obtained in a direct measure of length with a scale or

tape. For example, if a carpenter measures a piece of lumber, he usually knows whether he is certain of his result within an inch or one eighth of an inch. By close attention to his work, he could tell more accurately.

From the probable error in a and the estimated error in l , find the probable error in r . (See pp. 22 and 23.)

QUERIES: Is there any limit to the radius which can be measured by a given spherometer? Explain.

Would it be necessary in using an instrument of this kind to observe the direction of rotation of the disk?

EXPERIMENT A₃. Calibration of a Thermometer Tube.

The ideal thermometer tube is one in which the bore has a uniform cross section throughout its length. This very desirable feature is not obtainable in practice; hence, for accurate determinations of temperature, the thermometer must either be calibrated or compared with a standard instrument whose errors are known. The calibration will include errors due to graduation as well as those due to varying cross section of the bore of the tube. In the experiment which follows, either an ordinary traveling microscope or the unaided eye may be used to make readings on the ends of a mercury thread of suitable length at its several positions as it is moved from place to place in the tube to be calibrated. In order that the volume of the mercury thread remain constant, the experiment should be performed where no temperature changes occur.

In the method of calibrating a thermometer tube here described,* if the unaided eye is used, it is well to place the tube on a mirror, making readings when the ends of the thread are in line with the image seen in the mirror, estimating tenths of the smallest divisions into which the scale is divided.

Obtain a thread equal to about one tenth of the graduated stem, but not over three centimeters long. If the thread is too long, it gives the average volume of too long a section of stem,

* See Heat for Students, Edser, Chap. II.

and if too short, the percentage errors in reading the lengths of the thread are liable to be too great for the desired accuracy. If the thermometer has an expansion chamber at its upper end, it may be inverted and a portion of the mercury run into the chamber. Then gently heat the bulb over a Bunsen flame until the desired length of thread is forced into the capillary, when a quick but gentle jerk of the thermometer, parallel with its length, will give the desired thread. If the thermometer has no expansion chamber, it often happens that a sudden movement of the thermometer, parallel with its axis in a direction away from the bulb, will separate a thread due to a contraction where the bulb is joined to the stem. The desired length may be obtained by trial, heating or cooling the bulb to vary the length of the column in the stem beyond the contraction. Sometimes it is necessary to heat the stem with a small pointed gas flame at the point where separation is desired. In order to study the tube at the lower end, it may be necessary to produce a contraction of the remaining mercury by covering the bulb with filter paper, or two or three layers of cheesecloth, and saturating it with alcohol or ether.

It is sometimes necessary to obtain two threads, using one over the lower range and the other over the upper range, causing them both to traverse an intermediate portion of the tube. This permits the determination of the ratio of the two lengths and the reduction of the readings to those of a single thread. In general, the length of the thread to be used depends on the length of the stem to be calibrated and the accuracy to be attained.

The thread being detached, it is now necessary to measure its length in scale divisions at different parts of the stem, working from one end to the other. If the graduations are equally spaced and the tube be of uniform bore, the length of the thread will be the same in all parts. As, in general, the tube is not of uniform cross section, the lengths will vary, since the volume of the thread is supposed to remain constant. The variations in

length of thread are to be used in calibrating the tube as outlined in the following example.

Assume a thermometer whose scale is graduated in degrees to be calibrated from 0° to 100° . The two ends of the thread give the readings in the following table in moving it stepwise along the tube.

| Readings on Thread. | | Length of Thread. | Variation of Length from Mean $L - l$. | Corrections. |
|-------------------------------|---------------------------------|-------------------|---|----------------------------------|
| End nearest 0° Mark. | End nearest 100° Mark. | | | |
| -.2 | 9.4 | $l_1 = 9.6$ | + .09 | + .09 = + .1 nearly |
| 9.6 | 19.1 | $l_2 = 9.5$ | + .19 | + .28 = + .3 nearly |
| 19.0 | 28.5 | $l_3 = 9.5$ | + .19 | + .47 = + .5 nearly |
| 28.6 | 38.3 | $l_4 = 9.7$ | - .01 | + .46 = + .5 nearly |
| 38.6 | 48.2 | $l_5 = 9.6$ | + .09 | + .55 = + .5 ⁺ nearly |
| 48.1 | 59.7 | $l_6 = 9.6$ | + .09 | + .64 = + .6 nearly |
| 59.5 | 69.3 | $l_7 = 9.8$ | - .11 | + .53 = + .5 nearly |
| 69.4 | 79.3 | $l_8 = 9.9$ | - .21 | + .32 = + .3 nearly |
| 79.6 | 89.4 | $l_9 = 9.8$ | - .11 | + .21 = + .2 nearly |
| 89.3 | 99.2 | $l_{10} = 9.9$ | - .21 | - .00 = 0 nearly |

Mean length $L = 9.69$.

The third column in the table gives the thread length, the fourth column gives the variation from the mean length, and the fifth column the correction to be applied. Since the errors

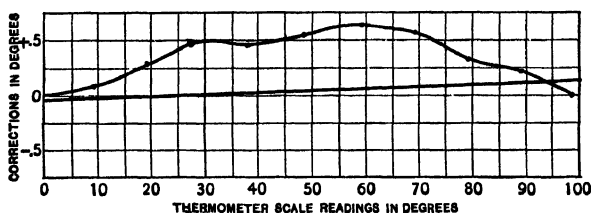

Fig. 5.

are accumulative, the fifth column is obtained by taking the algebraic sum of the errors from the zero up.

The corrections at the right of the last column are to be applied at the upper readings of the corresponding sections of the tube. A curve, Fig. 5, is to be plotted with corrections as ordinates and corresponding scale readings as abscissas. Draw a smooth curve through the points plotted.

If the zero and boiling points are correct, the calibration curve will give the true temperature corrections to be applied. But if either or both of these fixed points are in error, this is not the case. If the errors of the fixed points be plotted on the same sheet as the calibration curve and a straight line be drawn connecting them, the ordinates intercepted between it and the calibration curve will give the true temperature correction curve. By taking a sufficient number of these temperature corrections and using them as ordinates, plot another curve, using temperatures as abscissas. This new curve will give temperature corrections directly.

Follow the method outlined above in the calibration of a thermometer tube. Determine the freezing and boiling point corrections for the thermometer supplied, and finally plot a calibration curve for the thermometer.

To find the boiling-point correction, place the thermometer in a steam bath in such a manner that just enough of the stem is exposed to give a reading, being careful to wait at least five minutes before making a reading, in order that the thermometer may attain a steady reading. Next expose about 20° of the stem and make another reading of the boiling point. Repeat this process until nothing but the thermometer bulb is immersed in the steam. From computations based on these readings a stem-correction curve is to be plotted.

To find the zero-point correction, the thermometer bulb is to be surrounded with finely broken ice placed in a funnel, so that the water runs off.

EXPERIMENT A₄. Determinations of volumes and densities of solids by measurement of their dimensions.

I.

Determination of the volume of a regular solid by measurement of its dimensions.

If the solid is a parallelepiped, measure each of its twelve edges on the dividing engine. If it is a cylinder, measure its

altitude in four places, and measure the diameter of each base in four different places. In each case great care should be taken that the microscope moves parallel to the line measured. From the data obtained compute the volume. If the solid proves to be pyramidal or conical, treat it as a frustum. As a check upon the result, weigh the solid in air and in water. The difference of these weights, in grams, is numerically equal to the mass of the displaced water, and this quantity divided by the density of water at the observed temperature will give the volume of the solid. In weighing in water, free the solid from air bubbles, and correct for the weight of the suspending wire. More accurate results may be obtained by correcting for the buoyancy of the air. (See Exp. G₃.)

II.

Determination of the volume and density of a wire, from measurements of length, diameter, etc.

If the wire is insulated, it should first be carefully stripped in such a way as not to scratch the surface or change the shape of the cross section. Then measure the diameter, at ten or twelve different points throughout the length, with a micrometer wire gauge. Before using the micrometer, its zero point should be tested; if it is found to be incorrect, a suitable correction must be made to each reading. However, the *original readings* are to be entered in the notebook and corrections for zero error of the instrument are to be made later. Measure the length of the wire as accurately as possible, and compute its volume, treating it as a cylinder whose diameter is the mean of the diameters measured.

(If, however, the diameter is found to decrease progressively from one end to the other, the wire should be treated as the frustum of a cone.)

Finally, weigh the wire and compute its density. Check the last result by determining the specific gravity by weighing in water. (See Exp. G₁.)

III.

Measurement of the diameter of a wire by the microscope, and determination of density from diameter, length, and mass.

First determine the value in millimeters of one division of the micrometer eyepiece. To do this, focus the microscope on an accurate scale, and observe how many divisions of the scale are covered by any convenient number of micrometer divisions.

Measure the diameter of the wire at ten or twelve different points, by means of the micrometer eyepiece, and then compute the volume and density of the wire as in II, above.

EXPERIMENT A₅. Determination of the time of a periodic motion.

I.

By the method of middle elongations.

The method illustrated by this experiment affords a means of determining the vibration period of an oscillating body with great accuracy. It is used, for example, in determining the time of vibration of the suspended magnet of a magnetometer, in determining the period of a pendulum, etc. With the object of affording practice in the use of the method, the apparatus is arranged as described below :

A heavy disk (Fig. 6), having a black spot or a pencil line on the edge, is suspended by a long wire, and is kept in vibration, when once started, by the torsion of the wire. Place a telescope in some convenient position near a clock, and adjust it so that the vertical cross-hair is in the prolongation of the wire. The black spot will then move back and forth in the field, passing the cross-hair twice in each vibration. Note the time of day (hour, minute, second, and *tenth of a second*) of each passage of the spot across the hair, for ten successive transits. To obtain the time accurately, observe the second hand of the clock and count seconds as indicated by it. Continue the count while observing the transit, looking occasionally at the clock to see that no mistake is made. In most

cases the time of transit will not correspond exactly to the beginning of a second. Observe the position of the spot at the second just before, and again at the second just after the transit; from the relative distances of these two positions from the cross-hair the tenths of a second can be estimated. This will doubtless at first be somewhat difficult, but after a little practice the estimation can be made with considerable accuracy. An experienced observer should be able to estimate twentieths of a second with certainty. Repeat the ten readings mentioned above at intervals of about fifteen minutes until three sets have been taken of ten observations each, noting carefully whether for the first vibration of each set the disk was moving to the right or to the left.

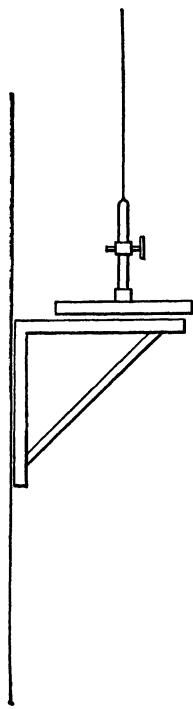

Fig. 6.—Disk for Torsional Vibrations.

To utilize these data in computing the period in question, add together the fifth and sixth time of transit in each set and divide by two. The result will be the time of the "Middle Elongation," or the time at which the spot was at its greatest distance from the cross-hair between the fifth and sixth transits.

If all the observations were correct, the same time of middle elongation would be found by adding together the fourth and seventh, the third and eighth, etc., and in each case dividing by two. In general, however, the five values obtained for the time of middle elongation will differ slightly on account of errors in the observations, and their average should be used. Subtracting the time of one middle elongation from that of the next, and dividing by the number of vibrations in the interval, gives the time of vibration with great accuracy. It is not necessary to count the vibrations; the number may be deduced from the observations themselves. Between the first and ninth, or second

and tenth observations of each set, there were four vibrations. Dividing the interval between the first and ninth observations by four gives an approximation to the periodic time. If the interval between two middle elongations is divided by this quantity, the quotient would, if the observations were all exact, be a whole number; * *i.e.* the number of vibrations in the interval. It should, with reasonably accurate observations, be near enough to a whole number to leave no doubt as to the true number of vibrations. Dividing the interval by this number gives the periodic time desired. As a check, the time of vibration should also be computed from the interval between the second and third middle elongations, and also between the first and third middle elongations.

It is to be observed that the interval which it is safe to allow between two sets of observations depends upon the accuracy of the observations, and upon the length of the period to be determined. If the period is short, the interval between two sets of observations must also be short. Determine, from a comparison of your observations, how long an interval would have been safe.

Repeat the experiment with the cross-hair to one side of the center, and show that the method pursued eliminates any such want of symmetry.

The principle of this method may perhaps be more clearly understood if the motion of the disk is represented graphically, as in Fig. 7. Horizontal distances here represent times, while vertical distances correspond to the displacement of the disk from its middle position.

The sinuous line in Fig. 7 thus represents graphically the displacement of the disk as a function of the time. The passage of the spot across the cross-hairs of the telescope corresponds in the figure with the intersection of the curve with the line $A'B'$. When the cross-hairs are placed in the prolongation

* It is to be observed that this quotient might also be a whole number plus a half. This would be the case if the disk moved in opposite directions at the beginning of the two sets of observations.

of the suspending wire, this line coincides with the middle line AB . In general it is displaced as shown. The time of middle elongation corresponds to the point M on the curve, and lies midway between the times 5 and 6, 4 and 7, etc. It is evident also that M lies midway between $5'$ and $6'$, $4'$ and $7'$, etc. In other words, the method is independent of the position of the

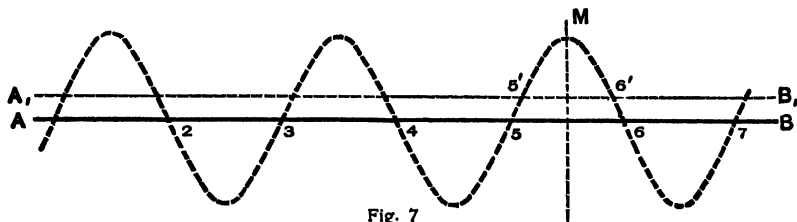

Fig. 7

cross-hairs. Since M corresponds to the time at which the vibrating body was at rest, it is clear that the time of middle elongation is independent of the position of the telescope. A movement of the latter between two sets of observations is therefore without effect on the result.

When the time of vibration is less than four or five seconds, the observations become difficult, and in such cases an electrical contact is provided by means of which the successive transits are automatically recorded upon a chronograph. The principle of the method remains, however, unaltered.

As an example of the employment of the method, the following set of observations is appended :

DATE: JAN. 4, 1894.

| <i>First Set.</i> | | | <i>Second Set.</i> | | |
|-------------------|-------|----------------------------|--------------------|-------|----------------------------|
| No. | h. m. | sec. | No. | h. m. | sec. |
| 1... | 3:14 | 10.2 | 1... | 3:35 | 9.3 |
| 2... | 3:14 | 23.7 | 2... | 3:35 | 22.8 |
| 3... | 3:14 | 35.9 | 3... | 3:35 | 35.0 |
| 4... | 3:14 | 49.3 | 4... | 3:35 | 48.4 |
| 5... | 3:15 | 1.5 | 5... | 3:36 | 0.7 |
| 6... | 3:15 | 15.0 | 6... | 3:36 | 14.2 |
| 7... | 3:15 | 27.2 | 7... | 3:36 | 26.4 |
| 8... | 3:15 | 40.7 | 8... | 3:36 | 39.8 |
| 9... | 3:15 | 53.0 | 9... | 3:36 | 52.1 |
| 10... | 3:16 | 6.4 | 10... | 3:37 | 5.6 |
| | | <i>Middle Elongations.</i> | | | <i>Middle Elongations.</i> |
| | | 5-6...3:15:8.25 | | | 5-6...3:36:7.45 |
| | | 4-7...3:15:8.25 | | | 4-7...3:36:7.4 |
| | | 3-8...3:15:8.30 | | | 3-8...3:36:7.4 |
| | | 2-9...3:15:8.35 | | | 2-9...3:36:7.45 |
| | | 1-10...3:15:8.30 | | | 1-10...3:36:7.45 |
| | | <i>Average, 3:15:8.29</i> | | | <i>Average, 3:36:7.43</i> |

Interval between first and second middle elongations = 20 m.
59.14 second = 1259.14 second.

Approximate time of one vibration computed from interval between 1st and 9th observation of first set = 25.7 second.

$$\frac{1259.14}{25.7} = 48.9 + ; \text{ nearest whole number} = 49.$$

$$\therefore \text{Period} = \frac{1259.14}{49} = 25.697.$$

It is probable that the result is correct to within a unit in the third place of decimals.

II.

Method of transits.

In several of the experiments which follow, the method of finding the periodic time which is described below will be found useful.

If the disk described in part A₅ I be vibrating rapidly, so that it is difficult to estimate accurately the time of each transit, it may be possible to estimate the time of every fifth transit to the right; say, as for example, transits 1, 6, 11, 16 ... 56.

If the time of the 1st transit be subtracted from the time of the 56th, the interval will be the time of fifty-five transits. In a like manner the time of the 6th transit subtracted from that of the 51st gives the time of forty-five transits and, finally, the time of the 26th transit subtracted from the time of the 31st transit gives the time for five transits. If these time intervals be added, the sum will be equivalent to the time of 180 vibrations. This method uses each observation once and only once, while a method used frequently to compute the periodic time from such data, by subtracting the time of the 1st from the 6th transit, the 6th from the 11th, and so on, and computing the mean period from these results, is equivalent to using the first and last observations alone and discarding all intermediate observations. The latter method is of use to check the accu-

racy of the count. The following example will show how computations of the periodic time are to be made by this method.

| Number of Transit to the Right. | Time of Transit. | | | Time of 5 Oscillations in Seconds. | Time Intervals between Transits as Indicated. | | |
|---------------------------------|------------------|----|------|------------------------------------|---|------|--------|
| | h. | m. | sec. | | min. | sec. | |
| 1 | 9 | 40 | 10 | 21 | 36-1 | 2 | 23 |
| 6 | | | 31 | 20.5 | 31-6 | 1 | 41 |
| 11 | | | 51.5 | 20 | 26-11 | 1 | 00 |
| 16 | 41 | | 11.5 | 20.5 | 21-16 | | 20.5 |
| 21 | | | 32 | 19.5 | 80 | 5 | 24.5 = |
| 26 | | | 51.5 | 20.5 | 324.5 sec. for the | | |
| 31 | 42 | 12 | | 21 | equivalent of 80 vi- | | |
| 36 | | | 33 | | brations. | | |

Periodic time = $\frac{324.5}{80} = 4.06$.

NOTE. — The above method of finding periodic time is to be used in experiments that follow as outlined below, it being kept in mind that observations are to be made always when the transits are in the same direction.

E_1 . Observe transits 1, 101, 201, ... 701, being equivalent to 1600 vibrations.

E_2 . Observe transits 1, 51, 101, ... 351, being equivalent to 800 vibrations.

E_3 . Observe transits 1, 26, 51, ... 176, being equivalent to 400 vibrations.

Q_2 . Observe transits 1, 11, 21, ... 91, being equivalent to 250 vibrations, if the period is not greater than 10 seconds. Observe transits 1, 6, 11, 16, ... 61 if the period is between 10 and 15 seconds. For periods greater than 10 seconds the method of A_5 I may be used, and must be used if period is greater than 15 seconds.

EXPERIMENT A_6 . The Balance and Its Use.*

The equal arm balance for comparing masses is one of the most useful of instruments in the physical and chemical labora-

* The following books should be consulted on the general theory of the balance: Stewart and Gee, vol. 1, pp. 63-73; Physical Measurements, Kohlrausch, 3d English Edition, pp. 30-43; Watson's Physics, § 95.

For a more complete account see Walker on the Balance.

tory. If properly used, measurements made by it are among those of greatest accuracy obtainable, often being to one part in a million in determining a mass of a hundred grams.

The balance consists of a light rigid beam supported at the center on a horizontal knife-edge. Near the two ends of the beam and in the same horizontal plane with the central knife-edge are two other knife-edges which support two scale pans on which the substance whose mass is to be determined and the known determining masses, "weights," are placed. A long pointer is attached to the middle of the beam. This pointer sweeps in front of a scale on which readings are made to determine a balance, as is described hereafter. The parts of the beam between the central knife-edge and the knife-edges near the ends of the beam are called the arms of the balance. The balance is supplied with counterweights, the ones moving vertically to raise or lower the center of gravity, and the ones moving on a horizontal axis to bring the knife-edges into a horizontal plane.

The knife-edges are protected from being made dull by jarring and slipping by a mechanism, called an *arrest*, which separates them from the planes against which they press when the balance is in use. The mechanism is operated by means of a milled head or lever at the front of the protecting balance case near the base.

Some of the chief mechanical conditions required of a balance by theory are:

- (1) The knife-edges should be in the same plane and parallel.
- (2) The knife-edges at the ends of the beam should be at the same distance from the middle knife-edge.
- (3) The pans should have equal mass — it being an advantage to make observations with the beam horizontal.
- (4) The center of gravity of the beam should be in the same vertical plane as the central knife-edge.

From theory we find for a balance whose knife-edges are in the same plane that the sensibility is greater, —

- (a) The longer the beam.

(*b*) The lighter the beam.

(*c*) The smaller the distance between the central knife-edge and the center of gravity of the beam.

(*d*) The smaller the friction of the knife-edges.

Since an increase in length of the beam makes an increase in its weight, it is necessary to make a compromise between conditions (*a*) and (*b*). The nature of this compromise is not entirely settled. Among other things the solution depends on the purpose of the balance; that is, whether it is to be used for weighing large or small masses.

If, according to the third condition the distance between the center of gravity and the central knife-edge be very small, the vibrations of the beam will become very slow and much time will be consumed in weighing. Usually, therefore, a compromise on this is made and the knife-edge adjusted as near the center of gravity as is possible without making the period of vibration too great.

If the balance is "knocked down" when assigned for use, it is to be put in adjustment by the student, great care being taken to place the beam on its *arrest* supports, and the pan supporting planes and pans on their proper sides, protecting the knife-edges from touching. Lower the beam by means of the milled head at the base of balance which shifts the arrests and raises the beam, and note if the pointer moves off the center. If it does, adjust the horizontal counterweights until it remains in the same position whether the beam is raised or lowered. This assumes that the *arrest* has been properly adjusted by the maker. If the maker has not properly taken care of this adjustment, it may be made by raising or lowering the supports used to free the end knife-edges, by carefully turning the capstan-headed screws of this part of the arrestment. See that the instrument is properly leveled, by means of the plumb line or level, put on by the maker, or if these are lacking, use a small hand level on the base, leveling by means of the three leveling screws of the base.

Now adjust the vertically moving counterweight to such a

position that the time of a complete swing is about that suggested by the instructor assigning the experiment.

The following precautions are always to be taken in using the balance :

Dust the pans with a camel's-hair brush before using.

See that the rider is in its place and that nothing interferes with the swing of the balance.

Always determine the zero of the scale before and after any weighing.

Never put anything on the pans which is likely to injure them.

In releasing and arresting the beam, be careful to avoid all jerks and always arrest the beam as it passes its position of equilibrium.

As the sensitiveness of a balance depends, among other things, on the sharpness of its knife-edges, it is therefore best that they should not be in contact with their bearings any longer than necessary. Under no circumstances should weights be added or taken from the pan if the balance is resting on its knife-edges.

If, when the balance is in equilibrium, there is difficulty in getting up a vibration, gently waft the air over one of the pans: Or the arrest may be raised and lowered again.

It is best to try the marked masses methodically in their proper order and to arrange them in order of magnitude on the pans.

Never touch the pans or marked masses with the fingers or with anything likely to injure them. A measurable change in a mass may be caused by a single touch.

Final weighings must be made with the balance case closed, and care must be taken that the pans do not swing.

Do not weigh a body when hot; the air currents will affect the weighings.

All liquids must be weighed in stoppered bottles. Water vapor will ruin knife-edges.

See that the beam is arrested and everything put away when the weighings are finished.

This experiment is divided into several parts as follows :

- I. Weighing by equal swings.
- II. Weighing by vibrations.
- III. Double weighing.
- IV. Weighing with a tare.
- V. Reduction to vacuo.
- VI. Sensibility of balance for various loads and periodic times.
- VII. Ratio of balance arms.
- VIII. Calibration of a set of weights.

The work to be done depends on the parts assigned. If $A_6 + G_2$ is the assignment, the specific gravity bottle is to be weighed by all of the methods, but only Paragraphs II, V, VI, and VII need be used to find the density of the three substances which are to be assigned by an instructor.

I.

Weighing by equal swings.

The method of weighing here outlined is very commonly used, but for accurate work it is never to be adopted. It is assumed that the balance is in perfect adjustment and that the pointer swings equal distances both sides of the middle scale division, which may be assumed the zero, on no load, allowance being made, of course, for ordinary damping.

The mass to be determined is placed in one pan and "weights" put on the other pan until the second and third swings on the two sides of the zero are alike. This necessitates the use of a rider. The first swing is discarded and the excursions to the right and left of the central division should not be over five or six divisions.

Weigh the given mass several times by this method, putting down each determination as made.

II.

Weighing by vibrations.

The most convenient as well as the most accurate method of weighing is "weighing by vibrations." Owing to the time required for the balance to come to rest and the fact that due to friction and other causes the balance does not always come to rest at its true equilibrium position, it is best to determine the zero by the vibrations themselves.

What seems at first sight to be the most simple method of weighing, that of adjusting the known masses on the pan until the balance is at rest at the zero position, is in reality much slower and less accurate than weighing by vibrations. In addition to the time required in waiting for the balance to come to rest, it usually takes a large number of trials to bring the balance to exactly the *same* position of equilibrium as that corresponding to zero load. Even after many trials there is often uncertainty about it. Furthermore, by the method of vibrations it is not necessary to adjust the masses until the pointer indicates exactly the zero point, *i.e.* the position of equilibrium corresponding to empty pans.

The method of getting the position of equilibrium consists in reading the "turning points" or the scale readings corresponding to the extreme positions of the pointer in its vibration and from these computing the mean. In reading the scale, it should be numbered as shown in Fig. 8, and tenths should be estimated by the eye, care being taken to avoid parallax. Since the amplitude of vibration decreases, it is not correct to take a reading at each end of the swing and then take the mean of these two readings as the position of equilibrium. One more reading should be taken on one side than on the other.



Fig. 8.

The following example illustrates the method of taking the readings. In the first column are given the readings of the "turning points" on the left-hand side and in the second column

those on the right-hand side of the scale The readings were of course taken in the order 3.2, 18.3, 4.0, 17.8, 4.4, 17.2, etc.

| LEFT | RIGHT |
|---------------|---------|
| 3.2 | 18.3 |
| 4.0 | 17.8 |
| 4.4 | 17.2 |
| 5.0 | 16.8 |
| 5.4 | 4)70.1 |
| <u>5)22.0</u> | 17.52 |
| 4.40 | 4.40 |
| | 2)21.92 |
| | 10.96 |

The method of finding the mean is shown in the table. Or if a_1, a_2, a_3 , etc., represent, the readings of the turning points on the left-hand side and b_1, b_2 , etc., those on the right-hand side, then

$$2x = \frac{\sum a}{n} + \frac{\sum b}{n-1},$$

where x is the reading of the position of equilibrium. On rough preliminary weighings two readings on one side and one on the other will usually be found sufficient.

Before placing the mass to be weighed on the balance, the beam should be lowered and set into vibration over about ten or more scale divisions, and after the pointer has made one or two swings, the exact turning points should be read. The reading corresponding to the position of equilibrium does not need to be exactly at the center of the scale, but should be somewhere near it. If not to be found so, the attention of an instructor should be called to it, unless the student has been directed to adjust the balance.

The readings for the position of equilibrium for the empty pans having been taken, the mass to be determined is placed in the left-hand pan and marked masses placed in the right-hand one until an approximate equilibrium is obtained.*

* Stewart and Gee, vol. 1, p. 74.

Equilibrium having been approximately obtained, the turning points are carefully read, and from these the reading corresponding to the position of rest obtained. This may be several scale divisions from the position of equilibrium for empty pans.

The next step is to determine the sensibility of the balance, or the number of divisions one milligram will shift the position of rest. The rider is shifted a distance on the arm corresponding to one milligram and the position of rest is again obtained from the turning points. The difference between this position and the other gives the sensibility or the value of a milligram in scale divisions. Knowing the zero taken with empty pans and the position of equilibrium with the masses on, the difference in scale divisions may be found. Say that it is 2.25 scale divisions. Suppose that it had been found that one milligram deflected the pointer 1.10 scale divisions. It follows that $2.25/1.10$ milligrams is, as the case may be, to be added to or subtracted from the marked masses in the pan to obtain the correct result. After the masses have been removed the equilibrium position should again be observed, and the mean of this and the one taken at the beginning of the set used instead of one alone.

Determine the given mass twice by the method outlined above.

III.

Mass by double weighings.

In accurate weighing it is necessary among other things to take account of or to eliminate the effect of the inequality of the lengths of the balance arms.

Gauss' method consists in making weighing with the mass to be determined first in one pan and then in the other. If a body whose true mass is W when placed in the left-hand pan, whose lever arm is l , balances weights R in the right-hand pan,

whose lever arm is r ; and when placed in the right-hand pan, balances a mass L in the left-hand pan,

$$Wl = Rr$$

and

$$Wr = Ll,$$

from which

$$W^2 = RL,$$

or

$$W = \sqrt{RL}. \quad (36)$$

Thus, it is seen that the true weight, neglecting bouyant force of the air, is the geometric mean of the two weighings.

Determine the mass of the given substance by the above method, using the method of weighing by vibrations.

IV.

Weighing with a tare.

Another method of eliminating errors due to inequalities in the lengths of the balance arms is that suggested by Borda, which consists of placing the mass to be determined in one pan and in the other to put any mass just sufficient to balance it. Then remove the body whose mass is desired and replace it with standard masses sufficient to produce another balance. It is convenient to use two riders in this method, one being considered a part of the tare whose mass may not be known.

Make two determinations of the mass by this method.

V.

*Reduction of weighings to vacuo.**

Another source of error which must be taken into account in accurate weighings, if the mass weighed has a density different from the weights, is the buoyant force of the air. If δ_a is the density of the air at a particular temperature, δ_w the density of the weights, and δ_s that of the mass to be determined, M_s the true mass and M the apparent mass, then

$$M_s = M \left(1 + \frac{\delta_a}{\delta_w} - \frac{\delta_a}{\delta_s} \right)$$

* See Exp. G₂.

advantage is the fact that it also obviates the mental confusion resulting from the continual interchanging of weights between the opposite pans. Thus is avoided one of the common sources of error in the beginner's work."

"It is, of course, necessary that all of the fractional weights should, taken together, constitute a gram; and because the milligram weights are never used, it is convenient to add an extra centigram weight from another set to supplement the other small weights. The different weights of the same denomination should be marked in a recognizable way, and should always be arranged in the same order in the box. The comparison usually begins with centigrams and proceeds upwards. One of the centigram weights is placed upon the left-hand scalepan, and is balanced by any suitable tare, care being taken that the rider is not too near either end of its path.* The zero point of the balance need not have been taken in the first place."

The equilibrium position of the pointer of the balance with its centigram load is now carefully determined, and then another centigram weight is substituted for the first. By noting the shift in the equilibrium position and determining the sensibility for the load, the variation of the second weight from the first is determined.

"The first weight is then replaced upon the left-hand pan, and if the swings correspond to the first observation, it is reasonably certain that the balance has remained in a constant condition throughout the trial, and hence that the difference between the two weights has been accurately determined. In this way every weight is compared with every other weight of the same denomination, as well as with the combination of all the smaller weights. Thus are obtained a number of independent equations one less

* "A crude set of weights is, of course, the most convenient tare, and a 5-milligram weight may be kept on the left-hand pan so that the rider may assume a convenient position. The use of the left-hand scalepan for the weights to be standardized renders a confusion of the sign of the correction less likely, because the rider is on the right. In this case, the weights are the objects to be weighed, and hence naturally take the left-hand position."

than the number of weights; and by assuming the value of any one of the weights the others may all be calculated."

"We have found it most convenient for the purposes of calculation to make the temporary assumption that the first centigram weight is correct. From it by the simplest possible process of addition and subtraction may be built up quickly the values of all the other weights. While the values thus computed are wholly consistent among themselves, they are usually far too different from the face values of the weights for convenient use. The reason of this is because the assumed standard is so small a quantity. It is necessary then to translate these consistent values into other terms by dividing every value by the value of one of the larger weights, to be taken as the new and permanent standard."

"The table below presents all the data and results of a sample standardization. . . . In the first column the weights are named by their face values, which are inclosed in parentheses in order to show that they do not signify true grams. In the second column are given the results of the mutual comparison of these weights copied from a notebook in which every detail of each weighing was recorded. The third column gives the actual values of the weights based upon the first centigram weight; these values are obtained by simply adding together the appropriate preceding values in the third and the last minute fractional weight enumerated in the second column. The aliquot parts of the value for the 10-gram piece, which is now to be taken as the permanent standard, are recorded in the fourth column, while the corrections sought, obtained by simply subtracting the numbers in the fourth column from those in the third, are given in the last vertical row."

"Owing to neglected fractions, the figures in the last column, when added together, are sometimes slightly discordant with those given in the second column. This is inevitable; of course such corrections should always be calculated to one decimal place beyond the figure which one wishes to have exact."

| Nominal Values. | Data obtained by Substitution Method. Grams. | Preliminary Values (actual). Grams. | Aliquot Parts of 10.01768 (Ideal). Grams. | Corrections in Milligrams (Actual Minus Ideal). |
|-----------------|--|-------------------------------------|---|---|
| (0.01) | = Standard of comparison | Standard | 0.01002 | - 0.02 |
| (0.01') | = (0.01) + 0.00006 | 0.01006 | 0.01002 | + 0.04 |
| (0.01'') | = (0.01') - 0.00001 | 0.01005 | 0.01002 | + 0.03 |
| (0.02) | = (0.01) + (0.01') - 0.00001 | 0.02005 | 0.02004 | + 0.01 |
| (0.05) | = (0.02) + etc. - 0.00007 | 0.05009 | 0.05009 | ± 0.00 |
| (0.1) | = (0.05) + etc. - 0.00006 | 0.10019 | 0.10018 | + 0.01 |
| (0.1') | = (0.1) + 0.00001 | 0.10020 | 0.10018 | + 0.02 |
| (0.2) | = (0.1) + (0.1') - 0.00004 | 0.20035 | 0.20035 | ± 0.00 |
| (0.5) | = (0.2) + etc. - 0.00011 | 0.50088 | 0.50088 | ± 0.00 |
| (1) | = (0.5) + etc. - 0.00004 | 1.00183 | 1.00177 | + 0.06 |
| (1') | = (1) - 0.00002 | 1.00181 | 1.00177 | + 0.04 |
| (1'') | = (1) - 0.00006 | 1.00177 | 1.00177 | ± 0.00 |
| (2) | = (1') + (1'') + 0.00025 | 2.00383 | 2.00354 | + 0.29 |
| (5) | = (2) + etc. - 0.00040 | 5.00884 | 5.00884 | ± 0.00 |
| (10) | = (5) + etc. - 0.00040 | 10.01768 | 10.01768 | Standard |
| | etc. | etc. | etc. | etc. |

In performing the experiment the 20-gram weight of the set to be calibrated is to be compared with a standard 20-gram weight which is to be taken as the standard in place of a 10-gram weight as indicated in the example given above.

EXPERIMENT A₇. The planimeter.

It is often desirable to know the area of a closed curve, as an engine indicator diagram or a hysteresis loop. There are various methods used for determining areas, such as drawing the curves to scale on cross-section paper and counting the squares, or cutting out the inclosed area from the paper on which it is traced, determining its mass and comparing it with the mass of a known area of the same kind of paper. A third method is to determine the area by a mechanical integrator. The type of integrator considered in the experiment given below is called a polar planimeter.

The planimeter consists of two arms hinged to permit relative motion in a plane. One arm has a needle point at its end

to fix its position and the other arm has a tracing point at its free end. In the arm carrying the stylus there is a wheel free to rotate about an axis in the line connecting the hinge and the tracing point. In connection with the wheel there is a counting device to indicate the number of turns, and a vernier to read fractions of a turn. Rotation of the wheel can take place only when the arm moves so that there is a component of the motion at right angles with the arm.

In moving the stylus about any closed area not embracing the needle point, the wheel revolves through an angle proportional to the inclosed area, the direction of motion of the stylus being in the same sense in all parts of its path. The principle involved is outlined briefly as follows : *

The area swept out by a line of length l having any motion whatever in a plane may be considered as made up of translations and rotations. For the translational part the area swept out will be equal to the product of the length of the line and the distance dx which the line moves in a direction measured perpendicular to its length

$$dA_t = ldx. \quad (38)$$

The part of the area swept out by the line due to its rotation about one end as an axis is equal to the length of the arc traversed by the other end multiplied by one half the length of the line,

$$dA_r = l d\phi \frac{l}{2} = l^2 d\phi / 2; \quad (39)$$

the total area swept out is therefore

$$dA = ldx + l^2 d\phi / 2. \quad (40)$$

If a wheel of radius r whose axis is in the line l be used to measure dx , then $dx = rd\theta$ and

$$dA = lrd\theta + l^2 d\phi / 2. \quad (41)$$

* More extended proofs may be found in Williamson's Integral Calculus ; Ferry and Jones, Practical Physics, and Miller's Laboratory Physics.

If one end of the line l is free and the other end is attached by means of a hinged joint, h , to another line of length R , whose opposite end is fixed at O , as in Fig. 9, the system may be considered to represent the arms of a polar planimeter. There are two cases of importance to be considered: I, when the tracing point p in tracing the outline of the figure does not comprise the fixed end O of the arm R , and II, when it does comprise the point O in going completely around the figure whose area is to be determined.

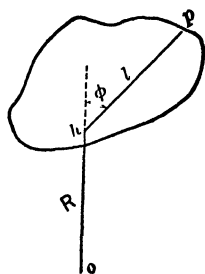

Fig. 9.

CASE I. The line R in rotating about O to the final position, which coincided with the initial position, sweeps out just as much area in rotating clockwise as in rotating in the opposite direction; consequently the net area is zero, considering clockwise rotation as positive and counterclockwise rotation as negative. The line l will sweep over a part of the area covered in its motion just as many times in a counterclockwise as in a clockwise direction, and since the final position of the line coincides with the initial position, the rotational part of the area covered will be zero, as is indicated in the following expression,

$$A = \int_0^\theta l r d\theta + \int_\phi^{\phi'} \frac{l^2}{2} d\phi. \tag{42}$$

From which $A = l r \theta = k s,$ (43)

in which k is a constant and s is the net number of divisions the wheel has turned and is proportional to the angle θ . The factor k is determined by the manufacturer of the planimeter, or may be easily determined by the user thereof.

CASE II. It is seen that if the tracing point p moves completely around O and returns to its original position in such a manner that the plane of the wheel lies along a radius from the point O , no rotation of the wheel will take place, although a circular area will be inclosed within the line followed by the tracing point. The circle including this area is called the *zero*

or *datum* circle. If the tracing point is at a distance from O greater than the radius a of the datum circle and moves around O in a clockwise direction, say, the wheel w will roll in one direction and the area indicated is to be added to that of the datum

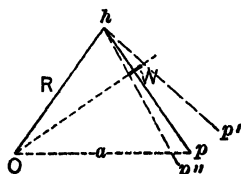

Fig. 10.

circle. If the distance to p is less than that of the radius of the datum circle, as ap'' and the rotation about O again be clockwise, the wheel will roll in the opposite direction. The indicated area in this case is to be subtracted from the area of the datum circle. In the general case,

when the tracing point moves completely around O , the area indicated on the wheel is to be added to or deducted from the area of the datum circle, depending on whether the net rotation of the wheel has been in one direction or the other.

The experiment consists of the calibration of a planimeter and its use in finding the areas of several figures. In all of the experimental work, if a student is working alone, he should make at least five readings on each part of the experiment. If two students are working together, each student should make at least three readings on each part.

In making the calibration of the planimeter, you are furnished with a metal plate on which there is a triangle, a circle, and a square. The dimensions of these figures are to be measured with an ordinary centimeter scale, and readings made to $\frac{1}{10}$ of a millimeter in order to determine the areas of these figures. The planimeter is then to be used on these figures, the movable point moving completely around the figures, and readings made on the vernier and counter to determine the number of divisions of the wheel necessary to indicate 1 square centimeter. Then readings are to be made of the areas of the other figures furnished. There is also to be drawn by the student, on cross-section paper or on a page of his notebook, which may be cut out and added to the report, a blocked figure 8 like sample herewith, in which the upper part of the 8 is smaller than the

lower part. The area of each part of this figure 8 is to be measured, and then the planimeter is to be used on the whole figure, first going around the 8 by traversing the whole of the left side first, and then the right side back to the starting point. The figure 8 is then to be traversed by following the upper left side, the lower right, and around clockwise, then the lower left and upper right to the starting point. Compare these results of traversing the figure 8 in this manner with the sum and difference of the independent determinations of the two parts of the figure. In at least one case the area of a figure is to be determined, in which the fixed point O is within the figure.

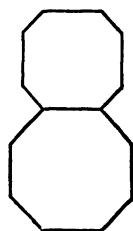

Fig. 11.

GROUP B: STATICS.

(B₁) *Parallelogram of forces*; (B₂) *Parallel forces, and principle of moments.*

EXPERIMENT B₁. The parallelogram of forces.

When a single force acts on a body, a change of motion takes place in the direction and sense in which the force acts. When more than one force acts on a body, each force produces its own effect, whether acting alone or with the other forces. Two equal forces acting in the same direction along the same line but in opposite sense produce no change in motion. A single force of proper magnitude, direction, and sense may be made to replace two or more forces acting at a point, since it will produce the same effect. Such a force is called the resultant of the several forces. A force of the magnitude and direction of the resultant force but in the opposite sense acting along the line of the resultant is called the anti-resultant, and if introduced into the force system of the several forces will produce equilibrium. Such a balanced force system is called a closed system of forces. In any closed system of forces any force may be considered the anti-resultant of all the other forces of the system. The resultant

of any force system may be found graphically by drawing the force polygon; that is, by plotting to scale the several forces in their proper directions and senses, in any order, care being taken to join the arrows representing the forces so that in going from

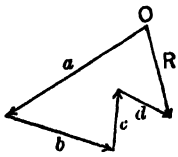

Fig. 12.

one arrow to the next the progression is always in the direction of the points of the arrows. The resultant will be represented in direction, sense, and amount by the arrow necessary to close the figure with its point at the point of the last force drawn. The anti-resultant will, of course, have the opposite sense, its point being at the beginning of the polygon. Such a force system is shown in the figure, in which the force R is the resultant of forces a , b , c , and d .

In the case of two forces only, a parallelogram may be drawn in which the opposite sides represent, respectively, the two forces and the proper diagonal represents the resultant. This parallelogram shows that the same resultant follows no matter in what order the forces are taken. In the experiment which follows, closed or balanced systems of forces are used. Pass two cords, having hooks at their ends, over two pulleys fixed to a horizontal bar. At two ends of the cords attach weights, the opposite ends

of the cords being attached to a ring as in the figure. Attach the third cord to the ring and suspend weights by it. Let the weights be suspended freely, and the system will come to rest with the angles, α , β , γ , of such values as to produce equilibrium of the system.

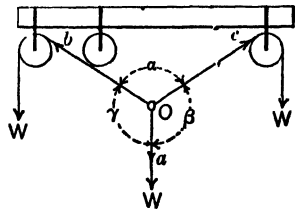

Fig. 13.

Measure the angles α , β , and γ by means of a protractor and make a note of the weights used, taking care to see that the system may move into its equilibrium position freely. For purposes of the experiment it is well to have the weights of such values as to have none of the angles very small. Make another set of readings,

using different weights. Make two other sets of readings, using systems in which there are four forces acting at a point.

For each set of readings plot the forces to scale, using a large plot. In each of the cases of the force systems made up of three forces, find the resultant of any two of the forces graphically, and compare the magnitude, direction, and sense of the resultant with the magnitude, direction, and sense of the third force. For the sets of readings where four forces were used find the resultant of any two forces; then combine this resultant with a third force, and compare the resultant of the three forces so obtained with the fourth force as noted in the cases of the three forces above. Compute and compare in every case the vertical components of all the forces and also the horizontal components.

A force table may be used in the above experiment. On this table the degrees may be marked at the edges. The position of the pulleys must be adjustable so that when the proper adjustment is attained, the center of the ring is in the center of the board. The student is to explain why this adjustment is necessary.

EXPERIMENT B₂. Parallel forces and principle of moments.

For equilibrium of concurrent forces it is not enough that the components of the forces in any direction must be zero, but also that the resultant moments must also be equal to zero, since the forces might produce rotation even when balanced for translation. Two cases will be studied: I, when the forces lie in the same plane and are parallel, and II, when the forces lie in the same plane but have various directions.

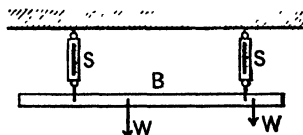

Fig. 14.

I. Suspend a uniform bar *B*, Fig. 14, horizontally by means of a pair of spring balances *S*, *S*, and suspend weights *W*, *W*

from the bar by means of hooks and pins. Adjust one or both supports of the spring balances until the bar is approximately horizontal. Observe the weights suspended, the mass of the bar, the readings of the spring balances, the horizontal distances from the points of application of all of the forces involved (considering the mass of the bar as concentrated at its center of gravity) to any point whatever, not a point of application of a force.

Find the difference between the upward and downward forces and the percentage variation from the mean. Find also the difference between the sums of the clockwise and contraclockwise moments and the percentage variation from the mean. It may be necessary to calibrate the spring balances, and also to determine their zero errors. If so, the corrected readings should be used in making the computations noted above.

Change the positions of applications of all of the forces, their values, by changing the values of the suspended weights, and also increase or decrease the number of suspended weights; make observations and computations as indicated in the first set of observations.

II. Build up a derrick model as shown in the figure, with uniform wood bars A and B , whose masses may be considered as concentrated at their geometrical centers, the spring balances at C and D , and the suspended weights at E . There are pin bearings at O and P which may be adjusted so that the bars A and B are vertical and horizontal, respectively. By means of force diagrams and the principle of moments,

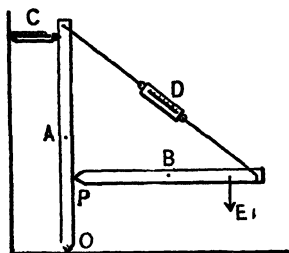

Fig. 15.

find the direction, sense, and amounts of the reactions at O and P . After these reactions have been determined take some point outside the derrick as a center of moments, so chosen that none of the moments about it

will be zero, and determine the sum of the moments with regard to the point.*

Find the variation of the sum of the moments thus found from the mean of the positive and negative moments.

GROUP C: FRICTION AND SIMPLE MACHINES.

- (C_1) *Coefficient of friction*; (C_2) *Law of wheel and axle*; (C_3) *Law of systems of pulleys*; (C_4) *Law of differential pulley*.

EXPERIMENT C_1 . To determine the coefficient of friction between two surfaces.

The apparatus, which is shown in Fig. 16, consists (1) of a smooth plate made of one of the materials to be tested and

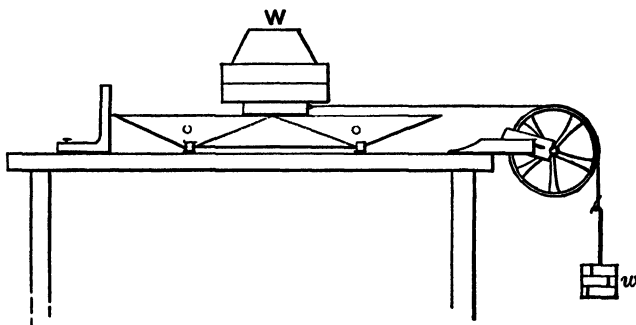

Fig. 16. — Coefficient of Friction.

capable of being adjusted so that its upper surface is accurately horizontal; (2) a small block of the second material in question which can be made to slide across the plate by means of a cord passing over a pulley and loaded with suitable weights.

Observations should be taken as follows:

First adjust the plate so that its surface is horizontal. Place the block upon it, and add enough weights to make the total pressure five kilograms. Then hang weights on the cord until

* It will be found advantageous to draw to scale a figure of the derrick, inserting the forces at their proper places with their proper directions and senses; assume a point on the drawing as the center of moments and base computations on distances measured on the diagram.

the force is just sufficient to keep the block moving uniformly when once started. Repeat the observations with pressures of 10, 15, 20, etc., kgs. on the block until a pressure of 50 kgs. is reached.

Each of the observations at different pressures should be independent and uninfluenced by any assumption as to the probable result. Friction, under the best of conditions, is irregular, so that it need not be at all surprising if the observations are somewhat discordant. The best final results will be obtained by making a number of entirely independent observations, each one being as carefully made as though it alone were to determine the coefficient.

Care should be taken in every case to start the load, because starting friction is greater than moving friction. The coefficient of moving friction is the quantity desired.

The surfaces should be carefully rubbed with filter paper before beginning the experiment, and should not be touched during the experiment, since the condition of the surfaces must not be altered.

It is to be observed that the weights upon the cord do not represent exactly the force required to overcome the friction between plate and block. A correction must be applied in each case on account of the friction of the pulley itself. To determine this correction it is necessary to find the coefficient of frictional torque of the pulley. This coefficient is to be determined by passing a cord over the pulley and suspending 1 kg. from each end, then adding a known mass, first to one side, then to the other, sufficient to produce uniform motion, and taking the mean from the proper mass. Repeat the process for 2, 3, 4, and 5 kgs. on each side. Then

$$\mu_p = \frac{m}{m + M + M + P}, \quad (44)$$

where μ_p is the coefficient of frictional torque, m the mass necessary to produce uniform motion, M the mass suspended from each side, and P the mass of the pulley.

Remembering that the force necessary to overcome pulley friction is equal to the normal pressure on the bearing times μ_p , a factor may be found, which, if multiplied into the mass suspended from the cord to produce sliding, will give the required tension in the horizontal part of the cord which is necessary in finding the coefficient of friction desired. In finding the normal pressure it is to be noted that the pull w' on the horizontal

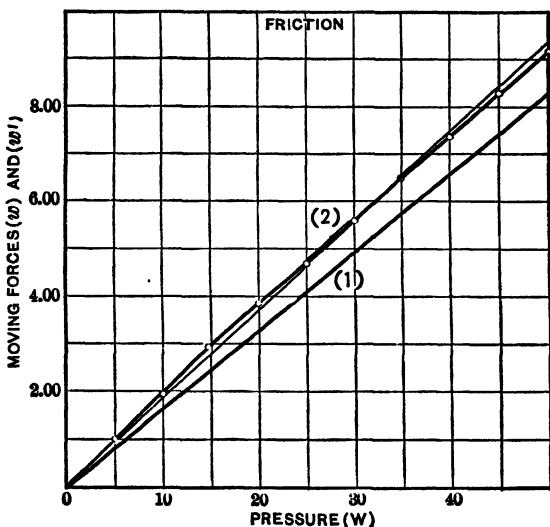

Fig. 17.

part of the cord is not very different from the suspended mass w . Therefore the normal pressure N on the bearing may be shown to be approximately equal to $w\sqrt{2}$.

Compute the value of the coefficient of friction for the surfaces for each load used.

Plot two curves to the same scale from the same origin: (1) using pressures W (Fig. 17) as abscissas and moving forces w' (w corrected for pulley friction) as ordinates, and (2) using pressures and total moving forces as co-ordinates. Find the equations of the first of the above-mentioned curves by the method of least squares.

If the mass of the block be considered, the curve should pass through the origin; in which case $b = 0$, and the value of a found by least squares is to be obtained from the expression

$$\Sigma xy - a \Sigma x^2 = 0. \quad (45)$$

(See Manual, p. 26, Eq. 31.)

Give the physical equation of the curve and interpret its slope and intercept, and get all possible physical constants from it. From the two curves get the coefficient of frictional torque of the pulley and compare it with that computed from the data taken.

The same apparatus may be employed to determine the influence of the area of contact upon the coefficient of friction, and also to study the "friction of rest," or "starting friction."

EXPERIMENT C₂. Law of the wheel and axle and determination of efficiency.

In this experiment a small weight suspended by a cord from a large wheel is made to lift a larger weight which hangs from the axle of the wheel.* The object of the observations is to determine experimentally the relation between the two weights when the smaller is just sufficient to keep the system moving. It is to be observed that the conditions differ from those considered in the simple theory of the wheel and axle, in the fact that the friction of the various parts is not negligible. The system forms, in fact, a simple type of machine, whose object may be considered to be the raising of weights. The effect of friction in reducing the efficiency of this simple machine is exactly the same in *kind* as it is in larger and more complicated machines, and the experiment thus affords an opportunity of studying the influence of friction in a simple case where the various disturbing factors may be readily isolated.

Observations are to be taken as follows:

* The experiment will perhaps be more instructive if a compound wheel and axle is used, or a compound system consisting of an endless screw and gear wheel. In these cases the influence of friction on the results will be much more marked.

Find by experiment the weights necessary to raise loads of 1, 2, 3, 5, 7, 10, 15, 25, 35, and 50 kgs., the small weight being adjusted in each case until it is just sufficient to keep the system moving with a slow, uniform motion, when started by the hand. Make several trials with each load and use the mean of the results. It is essential that each observation should be entirely independent of all the rest, and uninfluenced by any assumption

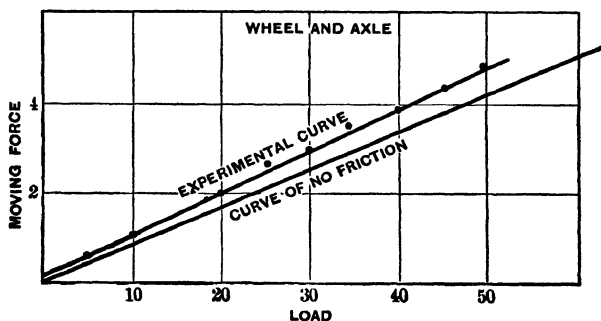

Fig. 18.

as to what the relation should be between "moving force" and "load."

From the data thus obtained, plot curves showing the relation between the moving force and the load in each case. Figure 18 shows such a curve. To locate points on these curves (which should be accurately drawn on cross-section paper), the loads are to be used as abscissas and the corresponding moving forces as ordinates.* From the appearance of the curves decide upon the form of their equations, and find the constants by the method of least squares. The lines represented by the equations that are obtained by least squares should be drawn on the same sheet as the original ones, in order to see how closely they represent the observations.

Having determined the velocity ratio in each case, show what the behavior of the apparatus would be if there were no

* Note that the horizontal and vertical scales need not be the same. See Introduction.

friction, and compute the efficiency of the apparatus, considered as a machine for lifting weights, for loads used as indicated above. A curve showing the relation between efficiency and load may then be drawn. (See Fig. 19.)

The velocity ratio may be roughly computed from the diameters of the wheel and axle; but on account of the appreciable thickness of the rope used, it is better to obtain the

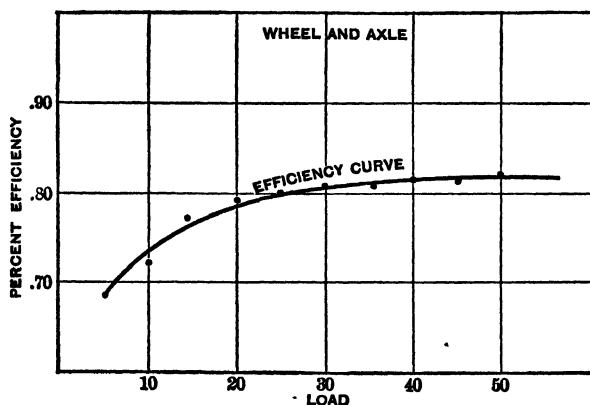

Fig. 19.

velocity ratio by actually measuring the distance passed over by the load when the wheel is turned a known number of times.

Addenda to the report :

(1) Interpret in detail the curves obtained. For example, the friction of the machine consists of two parts: (1) a constant frictional resistance, which is independent of the load; (2) a variable resistance becoming greater as the load increases. Each of these is readily determined from the curve.

(2) Indicate the greatest possible efficiency that can be attained by the machine, and the load to which this corresponds.

EXPERIMENT C₃. To determine the efficiency of a system of pulleys.

In this experiment a system of pulleys is used by which a small weight moving through a considerable distance is enabled

to lift a much larger weight through a comparatively small distance. The objects of the experiment are : (1) To determine experimentally the relation between "moving force" and "load" for uniform motion ; (2) to determine the efficiency of the system considered as a machine for raising weights. The procedure is as follows :

(1) Find by experiment the weights necessary to raise loads of 1, 2, 3, 5, 10, 15, etc., up to 50 kgs., the moving force being adjusted in each case until it is just sufficient to maintain uniform motion when the system is started by the hand. Make several trials with each load, and use the mean of the results.

(2) With the data obtained, plot a curve showing the relation between moving force and load, and from the appearance of the curve decide upon the form of its equation. The constants are to be determined by the method of least squares.

(3) Having determined the ratio of the distances passed over by the two weights, show what moving forces would be necessary to raise the same loads if there were no friction, and compute the efficiencies of the two systems for the various loads used.

Plot a curve based on the least squares on the same sheet as the experimental curve. Also plot on the same sheet an "ideal curve" of no friction, no pulley mass, based on the theory of the apparatus. This curve will pass through the origin and have a less slope than the experimental curve. Explain these points in detail and discuss the curves fully. An efficiency-load curve is to be plotted, its equation derived and discussed, and its asymptote located.

QUERIES : What change in the apparatus would cause the y -intercept of the line to increase? The slope of the line?

Is it true that the tension of the string on two sides of a pulley is the same when motion is taking place?

EXPERIMENT C₄. The differential pulley.

Study the pulley supplied, and briefly explain in your report the principle upon which it works.

friction, and compute the efficiency of the apparatus, considered as a machine for lifting weights, for loads used as indicated above. A curve showing the relation between efficiency and load may then be drawn. (See Fig. 19.)

The velocity ratio may be roughly computed from the diameters of the wheel and axle; but on account of the appreciable thickness of the rope used, it is better to obtain the

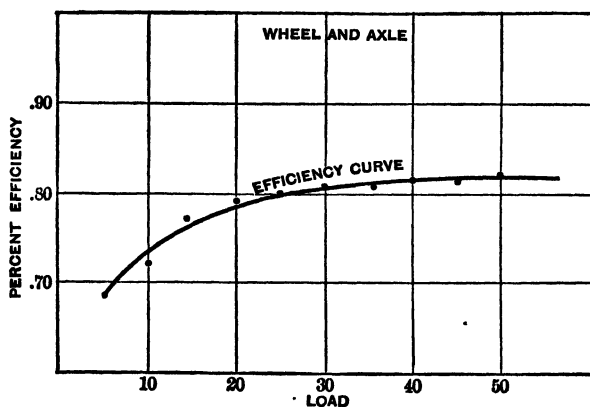

Fig. 19.

velocity ratio by actually measuring the distance passed over by the load when the wheel is turned a known number of times.

Addenda to the report:

(1) Interpret in detail the curves obtained. For example, the friction of the machine consists of two parts: (1) a constant frictional resistance, which is independent of the load; (2) a variable resistance becoming greater as the load increases. Each of these is readily determined from the curve.

(2) Indicate the greatest possible efficiency that can be attained by the machine, and the load to which this corresponds.

EXPERIMENT C₃. To determine the efficiency of a system of pulleys.

In this experiment a system of pulleys is used by which a small weight moving through a considerable distance is enabled

to lift a much larger weight through a comparatively small distance. The objects of the experiment are : (1) To determine experimentally the relation between "moving force" and "load" for uniform motion ; (2) to determine the efficiency of the system considered as a machine for raising weights. The procedure is as follows :

(1) Find by experiment the weights necessary to raise loads of 1, 2, 3, 5, 10, 15, etc., up to 50 kgs., the moving force being adjusted in each case until it is just sufficient to maintain uniform motion when the system is started by the hand. Make several trials with each load, and use the mean of the results.

(2) With the data obtained, plot a curve showing the relation between moving force and load, and from the appearance of the curve decide upon the form of its equation. The constants are to be determined by the method of least squares.

(3) Having determined the ratio of the distances passed over by the two weights, show what moving forces would be necessary to raise the same loads if there were no friction, and compute the efficiencies of the two systems for the various loads used.

Plot a curve based on the least squares on the same sheet as the experimental curve. Also plot on the same sheet an "ideal curve" of no friction, no pulley mass, based on the theory of the apparatus. This curve will pass through the origin and have a less slope than the experimental curve. Explain these points in detail and discuss the curves fully. An efficiency-load curve is to be plotted, its equation derived and discussed, and its asymptote located.

QUERIES : What change in the apparatus would cause the y -intercept of the line to increase? The slope of the line?

Is it true that the tension of the string on two sides of a pulley is the same when motion is taking place?

EXPERIMENT C₄. The differential pulley.

Study the pulley supplied, and briefly explain in your report the principle upon which it works.

Find the moving force just necessary to raise loads of 5, 10, 15 . . . 50 kgs. at a uniform rate. Find also the relative distances traversed by the working force and load. Compute the efficiency for each load.

Plot a curve, using loads as abscissas and working forces as corresponding ordinates. Plot another curve, using loads and efficiencies as co-ordinates.

Derive the constants of the first of the above curves by the method of least squares (Manual, pp. 24-28) and plot a curve based on these constants.

Discuss the curves fully.

Addendum:

Explain fully why the machine will not run backward if sufficient load is applied.

GROUP D: UNIFORMLY ACCELERATED MOTION.

(D₁) *Atwood's machine*; (D₂) *Determination of gravity from the motion of a freely falling body*; (D₃) *Angular acceleration, angular velocity, and rotational inertia.*

EXPERIMENT D₁. **Atwood's machine.**

In Atwood's machine a vertical standard, from two to three meters high, carries at the top a light pulley, *P* (Fig. 20), which is mounted in such a way as to make the friction of its bearings as small as possible. To the standard is attached a scale graduated in centimeters or inches for convenience in measurement. Over the pulley hangs a light silken cord, to which weights, w_1 , w_2 , may be hung. If equal weights are hung on the two sides of the pulley, it is evident that the system will remain at rest. But if a small additional weight be placed on one side, the condition of equilibrium will be destroyed, and the heavier side will begin to fall with a uniformly accelerated motion. The force of gravity acting on the small added mass, or "rider," *r* (Fig. 21), is thus utilized to set in motion a much larger mass,

and the acceleration is, in consequence, smaller than if the rider alone were moved. By suitably choosing the various weights, the motion may be made so slow that the velocity can be readily measured. The apparatus thus affords a means of illustrating the laws of uniformly accelerated motion, and can also be used, as explained below, to determine the acceleration of gravity, g .

For convenience in measuring time, most forms of Atwood's machine are provided with an electric bell or sounder, which can be connected with a seconds pendulum. By means

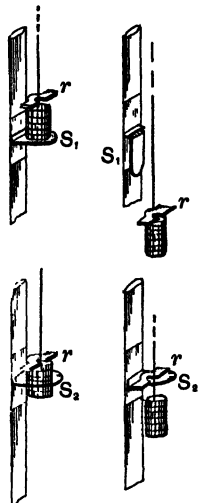

Fig 21.

of an electromagnet, m (Fig. 20), placed at the top of the vertical standard, and connected with the same circuit as the sounder, the weights may be released exactly at the beginning of a second, so that the necessity of estimating fractions of a second is avoided. A bracket, s_2 (Fig. 20), movable along the upright standard, may be adjusted so as to stop the fall at any point desired, while a ring, s_1 , also adjustable in position, serves to remove the rider at any desired time without disturbing the motion of the weights themselves.

I.

To test the laws of uniformly accelerated motion.

Hang equal weights on the two sides of the pulley, and then put enough additional weight on the side which is to fall during the experiment to overcome the friction of the apparatus. This

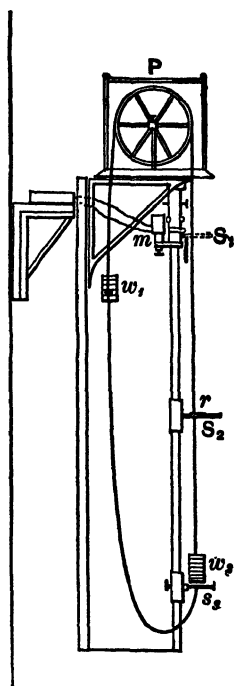

Fig 20.

can be done by adding small pieces of paper or tin foil until the weight will continue to move uniformly downward when once started. When this adjustment is completed, place the rider in position, and adjust the ring by trial to such a position on the vertical bar that it will remove the added weight after a fall of exactly two seconds. Measure the *distance traversed by the rider* and record it, together with the time of fall. Move the ring a few centimeters, in order to get independent readings, and make two more settings as before. Set the ring for the mean of the three readings; then place the bracket so that the mass will strike it after a uniform motion of 3, 4, and 5 seconds, making one careful setting for each. This constitutes one complete set of readings. Make three additional complete sets of readings for accelerations for 3, 4, and 5 seconds.

If the timing apparatus is arranged to beat half seconds, use $1\frac{1}{2}$, 2, $2\frac{1}{2}$, and 3 seconds for the acceleration periods in

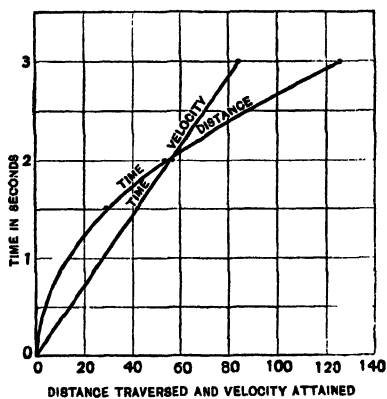

Fig. 22.

place of 2, 3, 4, and 5 seconds, and 2, 3, and 4 seconds for the periods of uniform velocity indicated above. If it is not possible to get uniform motion for the periods noted above, try some other series of three periods, as 1, 2, and 3.

From the data obtained find a value of the acceleration based on the mean distance traversed for uniformly accelerated motion, and another value of the acceleration from the computed velocity attained based on the determination of the velocity after the removal of the rider. Do this for each set and tabulate results.

The results are also to be shown by plotting two curves on the same sheet of cross-section paper, to the same scale, from the same origin (Fig. 22), using time in seconds for ordinates

in both cases, and using for abscissas velocities attained in one case and distances traversed in the other. Discuss the results and show whether or not they are in agreement with the laws of uniformly accelerated motion. Discuss the curves fully, giving the meaning of the slopes, the intersection of the two curves, and the relation between them.

II.

To use Atwood's machine for the determination of g .

If the mass of the rider is m , the resultant force acting on the system is mg . This force is equal to the product of the total mass moved into the acceleration imparted. If, therefore, the total mass except the rider be denoted by M , and the measured acceleration by a , we have

$$mg = (m + M)a; \quad (46)$$

g can therefore be computed as soon as m , M , and a are known. The mass m can be at once determined by weighing, while a can be computed from the observations. But the value of M cannot be so simply obtained, since the pulley itself forms a part of the mass set in motion. The "equivalent mass" of the pulley must therefore be first determined. To accomplish this, proceed as follows :

Hang half of the weights supplied with the machine on each side of the pulley. Add enough tin foil, as in part I, to overcome moving friction and produce uniform motion in the proper direction when the machine is started.

Make two settings of the ring that takes off the rider, so that it is removed after 2, 3, 4, and 5 seconds acceleration, making note of the distances passed through.

Remove one weight from each side, readjust for uniform motion with the rider off, and proceed as before. Continue to take off weights and make observations until only one of the equal weights remains on each side. If a reading for 5 seconds cannot be made, try the series, 1, 2, 3, and 4, dropping the 4 and 3 if necessary for the smaller masses.

Find the masses of one of the equal weights, the rider, and the pins and supports, to three significant figures.

From these observations, compute the acceleration imparted by the rider in each case. Since the equivalent mass of the pulley is known to be a constant, it may now be readily com-

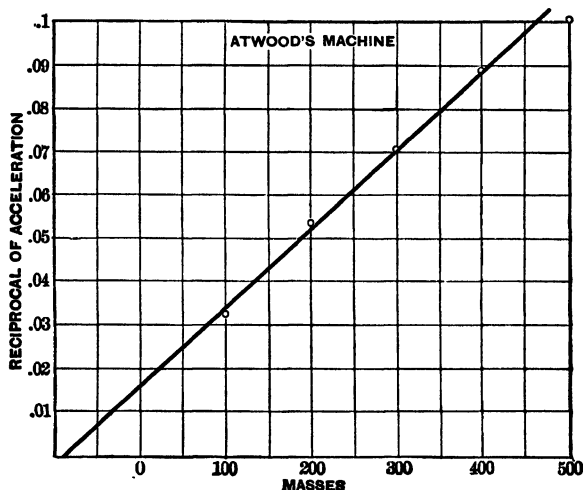

Fig. 23.

puted, either algebraically or graphically. The graphical method which follows is, however, recommended.

Plot upon cross-section paper a curve (see Fig. 23) in which the masses hung upon the pulley are used as abscissas, and the reciprocals of the corresponding accelerations as ordinates. This curve should, if the observations are good, be nearly a straight line. The equation of the line is, in fact,

$$\frac{1}{a} = \frac{1}{mg}(m + M) + \frac{1}{mg}M_0, \quad (47)$$

where M_0 denotes the constant equivalent mass of the pulley, and $m + M$ the sum of the masses hung from the cord. The co-ordinates of the curve are therefore $x = m + M$ and $y = \frac{1}{a}$; i e.

$$y = \frac{1}{mg}x + \frac{M_0}{mg}. \quad (48)$$

This is an equation of the first degree, and therefore represents a straight line.

Owing to errors of observation, the curve obtained will not be exactly straight. A straight line should, however, be drawn which passes as nearly as possible through all the points plotted. A little consideration will show that the intercept of this line on the axis of abscissas is equal to the equivalent mass of the pulley.

From the data obtained compute the values of g for each set, using the value of M_0 obtained from the curve. Get a value of g from the curve.

It may be readily proved that what has been called the equivalent mass of the pulley is really its moment of inertia divided by the square of the distance from its center to the cord. The work done by gravity when the rider has moved a distance l , is $mg l$, but this work must be equal to the kinetic energy gained.

$$\therefore mg l = \frac{1}{2}(m + M)v^2 + \frac{1}{2}K\omega^2, \quad (49)$$

in which v is the final velocity of the suspended masses, ω the final angular velocity of the pulley, and K its moment of inertia. Remembering that $v^2 = 2al$ and $v = r\omega$, this equation reduces to

$$mg = \left(m + M + \frac{K}{r^2}\right)a, \quad (50)$$

in which r is the radius of the pulley.

Addendum :

Find the tension in the cord on both sides of the pulley for both uniform velocity and uniformly accelerated motion. Account for the difference in the tension on the two sides in the second case.

EXPERIMENT D₂. Determination of g from the motion of a freely falling body.

Two forms of apparatus are used in this experiment, one of which, Fig. 24, is so arranged that a vibrating tuning fork of known pitch falls in front of a glass plate on which is a thin

coating of "Bon Ami" soap. In the second form of apparatus a small glass plate, treated in a similar manner, falls freely in front of an electrically driven tuning fork. A stylus attached to one prong of the fork is adjusted to trace a sinuous line on the glass as it falls. By measuring the length of a successive equal number of waves, 5 or 10 for the first form of apparatus and 1 or 2 for the second form, it is possible to compute the acceleration of gravity. As a means of measuring g , the method is not at all accurate, since any friction in the apparatus will

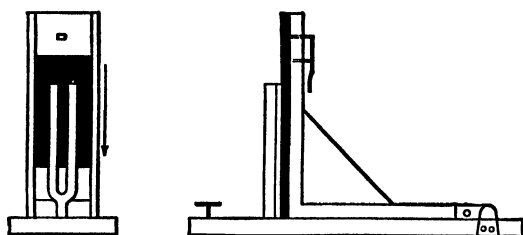

Fig. 24.

introduce a considerable error. The experiment is valuable, however, in illustrating the laws of falling bodies. Having covered the glass with a thin coating of "Bon Ami" with a wet cloth and allowing it to dry, adjust the stylus until it traces a smooth and distinct curve when the glass is allowed to fall. Several trials may be necessary before this adjustment is satisfactory. When a good curve has been obtained, stop the vibration of the fork, and allow the glass to fall a second time without changing the position of the glass.

The stylus will then be made to trace a straight line nearly through the center of the sinuous curve. (See Fig. 25.)

It may be found better, however, to use a straight edge and the point of a knife blade to get the center line. Mark an intersection of the straight line with the curve near one end, and calling that intersection number one, mark off intersections number eleven, twenty-one, thirty-one, and so on until ten spaces have been marked off. Then lay a scale down on the glass plate and note the positions of the marked intersections on the scale. For curves traced by the second form of apparatus, the dividing engine may be used, as in this form of apparatus it is necessary to measure intersections much closer together to get ten readings

on the plate. In this case, adjust the glass under the microscope of the dividing engine, assume some sharply defined intersection of the straight line and curve as a starting-point, and measure the distance from this to the third, fifth, seventh, etc., intersection. These distances, in either case, evidently represent the spaces passed over during the appropriate intervals of time as measured by the tuning fork. It is well not to start with the beginning of the curve, since the line may be more or less blurred and irregular in this region.

From these measurements, the acceleration of gravity can be determined in the following manner: Let v_0 be the velocity with which the falling body passed the point of the sinuous curve taken as origin. Let L be the distance from this point to an intersection passed t vibrations later. Then we shall have

$$L = v_0 t + \frac{1}{2} g t^2, \quad (51)$$

in which g represents the acceleration of gravity. If the series of observations taken be plotted, with values of L as ordinates and values of t as abscissas, the resulting curve will be a parabola. The constants v_0 and g may be determined from this curve by the method of least squares. As this is a quadratic equation, the numerical computations will be very laborious. It will therefore be desirable to use a linear equation if possible. This may be done as follows: Let l be the distance traversed *during* the t th interval as measured by the fork, counting from the assumed origin; then we shall have

$$l = v_0 - \frac{1}{2} g + g t. \quad (52)$$

If a series of corresponding values of l and t be plotted, this will give a straight line, from which the constants v_0 and g may be determined either directly by measurement or indirectly by the method of least squares.



Fig. 25

The constants may also be derived from two independent equations like the above. The two values of l taken should differ considerably, one being about twice the other.

In the above discussion, the unit of time is some multiple of the period of the fork. Therefore the values of v_0 and g obtained will be referred to it as the unit of time. Since v_0 varies inversely as the time, it is necessary, in order to express that constant in centimeters per second, that the values obtained be divided by the multiple of the fork period. For a similar reason, the value of g obtained must be divided by the *square* of the proper period if the acceleration of gravity is to be expressed in centimeters per second per second.

EXPERIMENT D₃. Angular acceleration and velocity; torque, and rotational energy.

The experiments in the D group preceding this one deal with the accelerations, velocities, and distances traversed by bodies having constant forces acting on them. This experiment, which is divided into two parts, deals first (part I) with the analogous relations of angular accelerations, angular velocities, and angular distances traversed by bodies acted on by constant torques, and second (part II) with the energy relations involved.

I.

Angular acceleration and velocity, and angular distance traversed.

If a body is acted on by a constant torque, it is found that the angular acceleration is constant. Let ϕ_0 and ω_0 , respectively, be the angular displacement and the angular velocity at the instant from which time is counted, and α be the constant angular acceleration.

$$\alpha = d\omega/dt, \quad (53)$$

from which
$$\omega = \int d\omega = \int \alpha dt = \alpha t + \omega_0, \quad (54)$$

or if the body starts from rest at the instant from which time is counted,

$$\omega = \alpha t. \quad (55)$$

Remembering that the angular velocity is the rate of change of angular position, equation 54 may be written

$$d\phi/dt = \alpha t + \omega_0, \quad (56)$$

which when integrated gives

$$\phi = \alpha t^2/2 + \omega_0 t + \phi_0, \quad (57)$$

in which ω_0 and ϕ_0 are, respectively, the angular velocity and the angular displacement when t is zero.

If the initial angular displacement is zero, ϕ_0 is zero and equation 57 becomes

$$\phi = \alpha t^2/2 + \omega_0 t. \quad (58)$$

As in D_2 this equation is an inconvenient one to use in relation to the apparatus at hand, but from it an equation may be obtained giving the angle turned through during any interval of time. The angle turned through during the t th second

$$\theta = \omega_0 - \alpha/2 + \alpha t. \quad (59)$$

The above equation is of the first degree, so that if successive equal time intervals be plotted as abscissas and corresponding values of θ be plotted as ordinates, a straight line will result. From the curve the angular acceleration may be found and also the complete time during which the angular acceleration has taken place.

The apparatus consists of a heavy disk, Fig. 26, which is caused to revolve with a uniformly accelerated angular motion about a fixed axis. The torque to produce the motion is obtained by a weight attached to a cord passing around the drum. A stylus actuated by an electrically driven tuning fork traces a sinuous line on the broad edge of

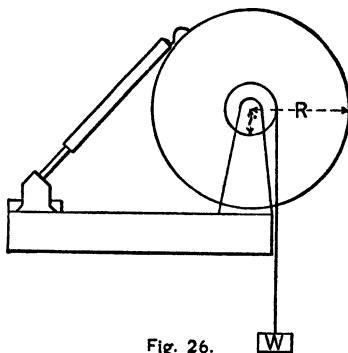

Fig. 26.

the disk, which has been previously coated with a mixture of whiting and alcohol. The fork is attached to a support which may be moved so that the sinuous line does not overlap as the wheel turns. The disk is graduated in degrees on one side. An adjusting screw permits variation in the pressure of the stylus on the edge of the disk.

Place the apparatus on a table so that the cord to which the weight w is attached may have a free motion as it unwinds from the drum. Connect the terminals of the electromagnet of the electrically driven fork in series with a suitable variable resistance and a storage battery. Coat the edge of the disk with the mixture of whiting and alcohol, being careful to get a thin, smooth, uniform coating. Adjust the stylus to bear on just hard enough to give a good clear tracing on the edge of the disk. Suspend such a mass w by means of the cord that, when it is released by hand from a height of 80 to 100 cm. from the floor, it will reach the floor in from 5 to 8 seconds. When the above conditions have been met, wind the cord on the drum, bringing the mass w up to a known distance above the floor, start the electrically driven fork, and allow the weight to drop. Move the support carrying the fork in such a way as to get a good sinuous curve not overlapping, continuing the curve for at least one complete turn of the wheel after the mass w reaches the floor, in order to determine the negative acceleration due to frictional torque alone. Assuming a unit of time of 50 complete vibrations of the fork and starting near the beginning of sinuous curve mark off every 50th wave throughout the length of the curve, so as to get both positive and negative angular accelerations. Read the angular position of each 50th wave, note the frequency of the fork, and measure the diameters of the disk and drum. The difference of the angular positions noted above will give the angles passed through in successive time intervals. Find these intervals and plot the successive differences in *radians* as ordinates, using as abscissas the corresponding successive time intervals 1, 2, 3, etc. It will be found

that the points lie along two straight lines, making such an angle that one has a positive slope and the other a negative one. (Why?) Draw the two curves until they intersect. (Why not draw a smooth curve to connect the two tangents?) From these curves, find the positive and negative angular accelerations in terms of the unit of time used and also in radians per sec². (See D_2 for method of reduction.) Find also the angular velocity at the instant of beginning to count time; also at the instant the mass struck the floor, in radians, and also find the time that elapsed from the instant the wheel started to revolve until the mass w struck the floor.

Compute the values of ω_0 and α by elimination, from two sets of suitably chosen pairs of observations, and compare them with the results obtained graphically.

Make a total of two sets of observations, using different masses as widely different as possible, yet keeping within the time limits noted above.

II.

*Torque, rotational inertia, and rotational energy.**

When a force acting on a body produces an acceleration, the acceleration is found to be directly proportional to the force acting and inversely proportional to the inertia of the body, which is measured by the mass. The acceleration is in the direction in which the force acts, and is uniform for a given mass so long as the force remains constant. It is necessary to bear in mind that if the force varies, the acceleration varies directly with it and that the usual types of motion studied in a laboratory course are those in which the force remains constant or varies in some simple way, as in the cases of uniform circular motion or simple harmonic motion. In the cases just cited the forces are constant in amount but changing in direction for the

* The general statements in the E group regarding moments of inertia should be studied in connection with this part of the experiment.

first case, and in the second case the return force is proportional to the displacement, whether it be linear or angular.

In part I of this experiment a constant force acting at the end of a constant lever arm comprises a constant moment or torque L which produces a constant angular acceleration α . It is found that the angular acceleration produced is directly proportional to the torque applied and inversely proportional to the rotational inertia of the body. The rotational inertia of a body depends upon the distribution of the material of the body with respect to the axis about which the body rotates. The rotational inertia of any body with respect to an axis is called the Moment of Inertia, K , with respect to that axis, and it may be shown that the rotational inertia K is equal to the summation of products of the linear inertia or mass of each small element of the body and the square of the distance of the element from the given axis; *i.e.*

$$K = \Sigma \Delta m r^2 = \int dm r^2. \quad (60)$$

From the relations indicated above,

$$\alpha = L/K \text{ or } L = \alpha K. \quad (61)$$

The work done when a constant torque twists through an angle θ is equal to the product of force times distance or

$$W = L\theta. \quad (62)$$

The kinetic energy of a rotating body may be shown to be

$$E_K = \frac{1}{2} K \omega^2 \quad (63)$$

in a manner analogous to finding the kinetic energy of translation, and is equal to the work done on the body to give it the given angular velocity.

It is the object of part II of this experiment to show (1) that the loss of potential energy of the mass dropping to the floor from its maximum height is equal to the total kinetic energy gained by the system, taking account of the work done against friction; and (2) that the resultant torque (taking account of the frictional torque) is equal to the product of the rotational inertia of the system and the angular acceleration.

The data taken in part I of the experiment together with the mass of the disk and the vertical distance the mass drops are sufficient to show the above relations.

GROUP E: MOMENT OF INERTIA AND SIMPLE HARMONIC MOTION.

(E) *General statements; (E₁) The physical pendulum; (E₂) Kater's pendulum; (E₃) Relations between the time of vibration and the position of the knife-edges in a uniform cylindrical pendulum.*

E. General statements concerning the moment of inertia and simple harmonic motion.

The moment of inertia of a body, with respect to a right line taken as an axis, is the sum of the products of each element of mass by the square of its distance from the axis. If K_a is the moment of inertia of any body with respect to the axis a , dM any element of mass, and r its perpendicular distance from the axis a , we have

$$K_a = \int r^2 dM, \quad (64)$$

in which the integral is extended to every element of mass of the body.

Moment of inertia bears the same relation to motion of rotation that mass bears to motion of translation. The following dynamical relations may readily be derived from definitions and Newton's second law of motion.

1. $\left\{ \begin{array}{l} \text{Momentum} = \text{mass} \times \text{velocity.} \\ \text{Moment of momentum} = \text{moment of inertia} \times \text{ang. vel.} \end{array} \right.$
2. $\left\{ \begin{array}{l} \text{Resultant force} = \text{mass} \times \text{acceleration.} \\ \text{Resultant moment} = \text{moment of inertia} \times \text{ang. acc.} \end{array} \right.$
3. $\left\{ \begin{array}{l} \text{Kinetic energy} = \frac{1}{2} \text{mass} \times (\text{velocity})^2. \\ \text{Kinetic energy} = \frac{1}{2} \text{moment of inertia} \times (\text{ang. vel.})^2. \end{array} \right.$

The moment of inertia of a body with respect to any axis is equal to the moment of inertia of the same body with respect to

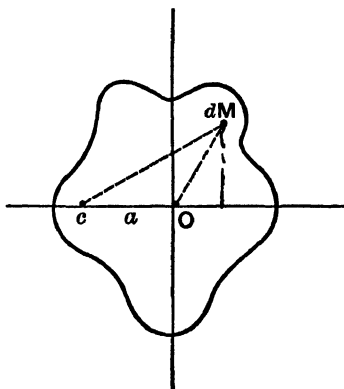

Fig. 27.

a parallel axis through the center of gravity, plus the mass of the body multiplied by the square of the distance between the two axes.

Let dM be an element of mass whose co-ordinates with respect to an axis through the center of gravity are x, y . Let c be an axis parallel to the axis through the center of gravity (Fig. 27) at distance a from it. Let K_0 and K_c be the moments of inertia with

respect to the two axes. Then we shall have

$$K_c = \int [(a+x)^2 + y^2] dM = a^2 \int dM + \int (x^2 + y^2) dM + 2a \int x dM, \text{ or}$$

$$K_c = Ma^2 + K_0. \quad (65)$$

The term $\int x dM$ is zero, for the origin is at the center of gravity of the body; this means that the sum of the positive products $x dM$ is just equal to the sum of the negative products $-x dM$.

Moment of inertia of an infinitely thin rod about an axis perpendicular to its length.

Let L be the length of the rod, S its cross section, δ its density. If dx is the length of the element of mass, we shall have

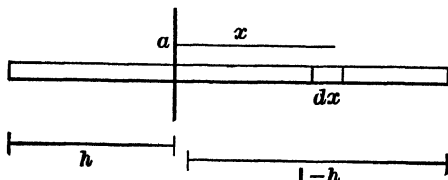

Fig. 28.

$dM = \delta S dx$. If x (Fig. 28) is the distance of the element of mass from the axis a , and h is the distance of the axis from either end of the rod, we shall have

$$K_a = \delta S \int_{-h}^{L-h} x^2 dx. \tag{66}$$

If M is the mass of the whole rod, this reduces to

$$K_a = M \left[\frac{L^2}{3} - hL + h^2 \right]. \tag{67}$$

Two particular cases are of especial interest; namely, when $h = 0$ and when $h = \frac{L}{2}$.

Moment of inertia of a cylinder about its axis of figure.

Let L be the length, a the radius, and δ the density of the cylinder. Take as element of mass an indefinitely thin, hollow cylinder, concentric with the axis, of radius r and thickness dr .

We shall then have $dM = 2 \pi r L \delta dr$. Therefore we have

$$K_0 = 2 \pi \delta L \int_0^a r^3 dr = M \frac{a^2}{2}, \tag{68}$$

in which M is the mass of the whole cylinder.

Moment of inertia of a circular lamina about any diameter.

Let a be the radius of the lamina, ϵ its thickness, and δ its density. Taking the element of mass in polar co-ordinates, we have

$$dM = \epsilon \delta r d\theta dr.$$

As the distance of the element of mass from the diameter is $r \sin \theta$ (Fig. 29), we have

$$K_0 = 2 \epsilon \delta \int_0^\pi [\sin^2 \theta d\theta \int_0^a r^3 dr] = M \frac{a^2}{4}. \tag{69}$$

Moment of inertia of a cylinder about any axis perpendicular to its geometrical axis.

Let L be the length of the cylinder, a the radius, δ the density, and h (Fig. 30) the distance of the axis from one end of the cylinder. Taking as element of mass a lamina of thickness dx , we have

$$dM = \pi a^2 \delta dx.$$

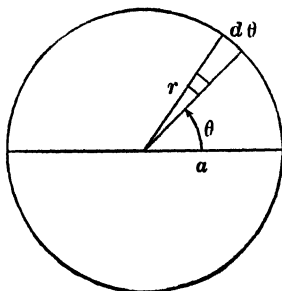

Fig. 29.

From equations 65 and 69 we have for the moment of inertia of this lamina, with respect to the axis a ,

$$dK_a = x^2 dM + \frac{a^2}{4} dM. \quad (70)$$

$$K_a = \pi a^2 \delta \int_{-h}^{L-h} x^2 dx + \frac{\pi a^4 \delta}{4} \int_{-h}^{L-h} dx,$$

and
$$K_a = M \left[\frac{L^2}{3} - hL + h^2 + \frac{a^2}{4} \right]. \quad (71)$$

Two particular cases are of especial importance; namely, when $h = 0$ and when $h = \frac{1}{2} L$.

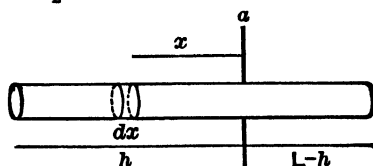

Fig. 30.

If h be given the value $\frac{1}{2} L$, then

$$K_0 = M \left[\frac{L^2}{12} + \frac{a^2}{4} \right]. * \quad (72)$$

The value of K_0 from equation 72 may be substituted in 65 to find K_c .

Simple harmonic motion.

An oscillating body is said to have simple harmonic motion when its distance, either linear or angular, from a fixed position is a simple harmonic function of the time of either of the forms,

$$\begin{aligned} x &= A \cos [\rho(t + t_0)], \\ x &= A \sin [\rho(t + t_0)], \end{aligned} \quad (73)$$

in which A , ρ , and t_0 are constants.

The distance of the body, either linear or angular, from the fixed position is called its *displacement*. The maximum displacement occurs when the cosine becomes unity. This

* A more elegant proof of this equation may be found in Shearer's Problems in Physics, problem 356.

maximum displacement is called the *amplitude* of the simple harmonic motion. In the above equation t_0 is a constant interval of time. This constant is obviously zero if time be reckoned from the instant when the displacement is a maximum in the positive direction, using the first of equations 73. When the time t has increased to the value $\frac{2\pi}{p}$, the displacement x is exactly equal to what it was at the instant $t = 0$. Moreover, at any time, t_2 , the displacement has the same value that it had at the time t_1 , if $t_2 - t_1 = \frac{2\pi}{p}$. The constant interval of time $\frac{2\pi}{p}$, during which the displacement takes all possible values, and the motion begins to repeat itself, is called the *period* of the simple harmonic motion. It is usually represented by τ or T .

Simple harmonic motion of translation.

The rectangular projection of uniform circular motion upon any diameter is simple harmonic motion; *i.e.* if the point N (Fig. 31) revolves about a circle with a uniform velocity, the point P will move along the diameter BC with simple harmonic motion.

Let A be the radius of the circle, let p be the constant angular velocity of the radius ON , and suppose time to be reckoned from the instant that the point P leaves the right-hand end of the diameter BC ; then at any time, t , we shall have *

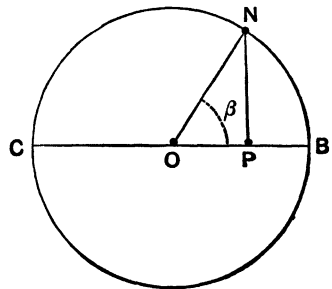

Fig. 31.

$$x = A \cos \beta = A \cos pt. \tag{74}$$

The distance, x , is the displacement, and A the amplitude, of the simple harmonic motion.

* It is to be understood that these equations hold for any simple harmonic motion, that the circle is an auxiliary circle, and that the motion of N is only to aid in understanding the real motion, which is along BC .

If the point P moves through the distance dx in the time dt , we have, from the definition of velocity,

$$v = \frac{dx}{dt} = -pA \sin pt. \quad (75)$$

If the velocity of the point P changes by the amount dv in the time dt , we have, from the definition of acceleration,

$$a = \frac{dv}{dt} = -p^2 A \cos pt. \quad (76)$$

Substituting for $A \cos pt$ its value from equation 74, we have

$$a = -p^2 x. \quad (77)$$

Equation 77 shows that the acceleration of a point having simple harmonic motion is at any instant proportional to its displacement from the mid-point. The negative sign shows that the acceleration is always directed oppositely to the displacement; *i.e.* when the point is at the right of the mid-point, its acceleration is directed towards the left, while the reverse is true when the point is on the left.

Multiplying both sides of equation 77 by the mass of the moving point, and remembering the dynamical equation $F = Ma$, we have

$$F = Ma = -Mp^2x. \quad (78)$$

This is a dynamical equation, and shows that the force which produces the acceleration of the mass M in simple harmonic motion is directed towards the mid-point and is proportional to the displacement.

Conversely, it may be proved that whenever the resultant force acting on a body is proportional to its displacement from a fixed position, the body will have simple harmonic motion.

From the equations 74, 75, and 76, it follows that the displacements, velocities, and accelerations of the point P begin to repeat themselves when t has increased from 0 to $\frac{2\pi}{p}$. This constant value of the time $\frac{2\pi}{p}$ is the period of the simple har-

monic motion; and is obviously the same as the time required for the point N to revolve about the auxiliary circle.

Substituting T for $\frac{2\pi}{\rho}$, equations 74, 75, and 76 now become

$$x = A \cos \frac{2\pi}{T}t, \quad (79)$$

$$v = -\frac{2\pi}{T}A \sin \frac{2\pi}{T}t, \quad (80)$$

$$a = -\frac{4\pi^2}{T^2}A \cos \frac{2\pi}{T}t. \quad (81)$$

It is often especially desirable to know the velocity with which the moving body passes the mid-point. It will first pass the mid-point after one quarter of a period has elapsed, and it will pass the same point for every odd number of quarter periods. Substituting for t in the equation for velocity any of the values $\frac{1}{4}T$, $\frac{3}{4}T$, $\frac{5}{4}T$, ..., we have

$$v_0 = \mp \frac{2\pi}{T}A = \mp \rho A. \quad (82)$$

Simple harmonic motion of rotation.

Let M be a body oscillating about an axis O (Fig. 32) perpendicular to the plane of the paper. The line OA , fixed in the body, oscillates between the extreme positions OA' and OA'' . The motion of the body will be simple harmonic motion, according to the definition above given, if we have at any time t ,

$$\phi = \delta \cos pt, \quad (83)$$

δ and p being constants.

If $d\phi$ be the angle turned through during the time dt , we shall have, from the definition of angular velocity,

$$\omega = \frac{d\phi}{dt} = -p\delta \sin pt. \quad (84)$$

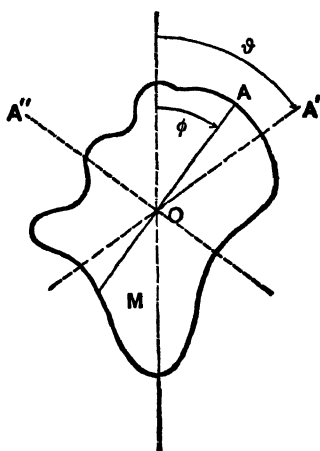

Fig. 32.

If $d\omega$ is the change of angular velocity in the time dt , we shall have, from the definition of angular acceleration,

$$\alpha = \frac{d\omega}{dt} = -p^2\delta \cos pt. \quad (85)$$

Substituting the value of $\delta \cos pt$ from 83, we have

$$\alpha = -p^2\phi, \quad (86)$$

from which it follows that in simple harmonic motion of rotation the angular acceleration at any instant is proportional to the angular displacement.

Multiplying both sides of equation 86 by the moment of inertia of the rotating body with respect to the axis of rotation, we have the torque

$$L = K\alpha = -Kp^2\phi. \quad (87)$$

Since, however, $K\alpha$ is equal to the resultant moment, with respect to the axis of rotation, of the forces acting on the body, it follows that the moment of the force producing the angular acceleration in simple harmonic motion is directly proportional to the angular displacement.

Conversely, it may be proved that if the resultant moment of the forces acting on a body with respect to the axis of rotation is proportional to the angular displacement from a fixed position, the resulting motion of the body will be a simple harmonic motion.

Here, as in simple harmonic motion of translation, the motion begins to repeat itself in all respects after a time $\frac{2\pi}{p}$ has elapsed. This constant time is the period of the simple harmonic motion, and, calling it T , equations 83, 84, and 85 become

$$\phi = \delta \cos \frac{2\pi}{T} t, \quad (88)$$

$$\omega = -\frac{2\pi}{T} \delta \sin \frac{2\pi}{T} t, \quad (89)$$

$$\alpha = -\frac{4\pi^2}{T^2} \delta \cos \frac{2\pi}{T} t. \quad (90)$$

If ω_0 be the angular velocity with which the body passes its mid-position, we have, in a manner similar to equation 82,

$$\omega_0 = \mp \frac{2\pi}{T} \delta. \quad (91)$$

Examples of simple harmonic motion of translation :

(1) If a mass be suspended by a spiral spring, it will oscillate along a vertical line with simple harmonic motion, if it is first displaced upwards or downwards from its position of equilibrium, and then set free.

(2) Any molecule in a sounding body or a sound-wave, when the sound is absolutely simple, *i.e.* without harmonics or overtones.

(3) The bob of a simple pendulum, or any point in a compound pendulum, when the arc of vibration is very small.

(4) Any point in a magnet vibrating in a uniform magnetic field when the arc of vibration is very small.

Examples of simple harmonic motion of rotation :

(1) A mass suspended by a wire or cord, and rotating about a vertical axis, the only force acting being the force of torsion.

(2) A compound pendulum when the arc of vibration is very small.

(3) A magnet vibrating in a uniform magnetic field when the arc of vibration is very small.

In these examples, as well as in all other cases, there are certain retarding forces due to friction, imperfect elasticity, or induced currents of electricity, which prevent the motion from being absolutely simple harmonic. This "damping," as it is called, has an extremely small effect upon the *period* of the simple harmonic motion, and may be safely neglected when the period is the quantity desired. When the amplitude of the simple harmonic motion is the quantity to be used, a correction for "damping" must generally be introduced.*

* See Nichols, *The Galvanometer*, Lecture 3; also Stewart and Gee, vol. 2, p. 364 *et seq*; and Exp. U₃.

EXPERIMENT E₁. Determination of g by the physical pendulum.

If a physical pendulum be displaced from its position of equilibrium through an angle so small that the angle may be substituted for its sine without appreciable error, the moment of the force acting on the pendulum will be proportional to the angular displacement. The pendulum must therefore have simple harmonic motion.

From the principle of the conservation of energy, in any transformation, the two forms of energy must be equal to each other. As the energy dissipated in a single swing of the pendulum is small enough to be negligible, we are justified in equating the kinetic energy of the pendulum when at its lowest point to the gain in potential energy when it reaches its highest point.

The kinetic energy of a rotating body is $\frac{1}{2} K_a \omega^2$. Since the pendulum has simple harmonic motion, the angular velocity at the mid-position will be $\frac{2\pi\delta}{T}$. (See equation 81.)

$$\therefore E_K = \frac{2\pi^2\delta^2}{T^2} K_a.$$

The potential energy at the highest point is equal to the work required to turn the pendulum through the angle δ from the lowest point. This work is equal to the average moment multiplied by the angular distance moved, or,

$$E_P = \frac{MgR\delta}{2} \delta.$$

Since $E_K = E_P$, we have

$$\frac{2\pi^2}{T^2} K_a = \frac{MgR}{2}, * \tag{92}$$

* Proof of the equation for the periodic time of the physical pendulum from the equation of motion.

Let

$L =$ torque.

Then

$$L = K\dot{\omega} = K_a \frac{d\omega}{dt} = K_a \frac{d^2\phi}{dt^2}, \tag{93}$$

in which K is the moment of inertia and $\dot{\omega}$ the angular acceleration. (Franklin and MacNutt, Elements of Mechanics, p. 131.)

in which T is the period of a complete oscillation, K_a the moment of inertia of the pendulum with respect to the axis of suspension, M its mass, R the distance of the center of gravity from the axis of suspension, and g the acceleration of gravity.

In the case of the physical pendulum the equation for the return torque may be written

$$L = -MgR \sin \phi, \quad (94)$$

or, when ϕ is so small that for $\sin \phi$ may be written the angle in radians,

$$L = -MgR\phi; \quad (95)$$

combining (93) and (95) and putting $\frac{MgR}{K_a} = C$, a constant,

$$\frac{d^2\phi}{dt^2} = -C\phi. \quad (96)$$

By multiplying the last equation by $2 \frac{d\phi}{dt}$ and integrating, it becomes

$$\left(\frac{d\phi}{dt}\right)^2 = -C\phi^2 + C', \quad (97)$$

in which C' is the constant of integration.

When $\frac{d\phi}{dt} = 0$, then ϕ is a maximum, ϕ_m .

By putting $\frac{d\phi}{dt} = 0$, and solving for C' ,

$$C' = C\phi_m^2.$$

$$\therefore \left(\frac{d\phi}{dt}\right)^2 = C(\phi_m^2 - \phi^2), \quad (98)$$

from which $\frac{d\phi}{dt} = C^{\frac{1}{2}}(\phi_m^2 - \phi^2)^{\frac{1}{2}}$,

or $\frac{d\phi}{(\phi_m^2 - \phi^2)^{\frac{1}{2}}} = C^{\frac{1}{2}} dt$. (99)

Integrating equation 99,

$$\sin^{-1} \frac{\phi}{\phi_m} = C^{\frac{1}{2}} t + C''. \quad (100)$$

Taking $t = 0$ when $\phi = 0$, the new constant of integration C'' is shown to be equal to zero.

When $t = \frac{T}{4}$, $\phi = \phi_m$,

then $\sin^{-1} \frac{\phi}{\phi_m} = C^{\frac{1}{2}} \frac{T}{4} = \sin^{-1} 1$. (101)

But the angle whose sign is 1 is $\frac{\pi}{2}$.

$$\therefore \frac{\pi}{2} = C^{\frac{1}{2}} \frac{T}{4}. \quad (102)$$

If T and R be observed, and K_a computed, the acceleration of gravity may be determined.

In this experiment a uniform bar of metal, provided with an adjustable pair of knife-edges (Fig. 33), is to be used as a pendulum. The method of procedure is as follows :

(1) Fasten the knife-edges firmly at some point not at the end of the bar, and set the pendulum to vibrating through a *small* arc.

(2) Determine the time required for the pendulum to make some large number of oscillations. (See A_5 II.)

(3) From the result compute the period of the pendulum to four significant figures in the manner explained in A_5 II. An



ordinary watch or clock may be used for determining this time, although a stop-watch is better. In any case, several determinations of the period should be made, in each of which the time is at least five or six minutes.

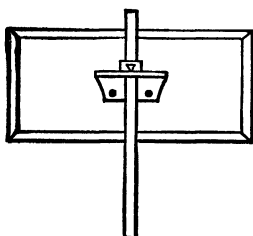

Fig. 33.

(4) After the period has been determined, measure the dimensions of the bar and the distance of the knife-edges from one end. From these data, the moment of inertia can be computed.

(5) Change the position of the knife-edges a few centimeters and make another complete set of observations for periodic time. Determine the position of the knife-edges as before.

From, equation 102,

$$T^2 = \frac{4\pi^2}{C}.$$

But

$$C = \frac{MgR}{K_a}.$$

$$\therefore T^2 = \frac{4\pi^2 K_a}{MgR}. \quad (103)$$

The same method may be applied to find the expression for the periodic time of the torsional pendulum, F_2 , or of the vibrating magnet, Q_2 , using the appropriate initial equations.

As the bar is homogeneous, the center of gravity will be at the center of the figure, and thus R is known. M will be found to cancel out; consequently g may be computed.

The knife-edges and clamp slightly affect the moment of inertia and the center of gravity of the pendulum, thus slightly changing the period. If greater accuracy is desired, the effect of the knife-edges and clamp on the period may be made zero by fastening to the knife-edges an auxiliary mass, a portion of which extends above the axis of suspension, and varying the center of gravity of this mass until the period of vibration of the knife-edges without the bar is approximately the same as the period of the bar pendulum.

The observations and computations for determining the periodic time are to be tabulated as shown in the example in A_5 II, and the dimensions of the pendulum and results as follows:

GRAVITY BY THE PHYSICAL PENDULUM

Dimensions of Pendulum and Results

| | |
|--|-----------------------------------|
| Distance of axis from upper end of bar, | 3.5 cm. |
| Length of bar, | $L = 159.6$ cm. |
| Diameter of bar, | $2r = 1.6$ cm. |
| Distance of axis from center of gravity of bar, | $R = 76.3$ cm. |
| Moment of inertia, | $K_a = 7945$ M. |
| Periodic time, | $T = 2.047$ |
| Computed value of gravity, | $g = 981 +$ cm. per sec. per sec. |
| Most careful determination for Cornell laboratory, | 980.28 |

Addenda to the report:

(1) Derive all formulas used and show that there is justification for assuming S. H. M. in this case.

(2) Derive the formula for the moment of inertia of the pendulum about its axis of suspension. Show that $K_a = K_o + MR^2$.

(3) Explain how the mass of the pendulum cancels so that it does not need to be known. Compute the acceleration of gravity in centimeters per second per second and in feet per second per second.

(4) Explain what is meant by the statement, The force of gravity is g dynes.

(5) Explain why a small error in the period will make an error relatively twice as great in g .

EXPERIMENT E₂. Determination of g by Kater's pendulum.

The equation for the physical pendulum may be put into the form

$$\frac{4\pi^2}{T_1^2}(K_0 + MR_1^2) = MgR_1, \quad (104)$$

in which K_0 is the moment of inertia of the pendulum with respect to an axis through the center of gravity parallel to the axis of suspension. (See equations 65 and 92.) If the pendulum be inverted, and the time of vibration determined for an axis on the opposite side of the center of gravity, a new equation will be obtained similar to the above, except that there will be new values of R and T . Between these two equations K_0 may be eliminated and g determined. To this end we substitute l for $R_1 + R_2$ in the equation derived by the elimination of K_0 from two equations like the above. It will then reduce to the equation for the simple pendulum, provided that the two times of oscillation are the same, and the two values of R are *not* the same.* Kater's pendulum is an apparatus which makes use of this fact.

The use of Kater's pendulum depends upon the principle that the center of oscillation and the center of suspension of any pendulum are interchangeable; *i.e.* if a pendulum is reversed, so that the point which was the center of oscillation is made the center of suspension, the time of vibration will remain unchanged. The distance between these two points being equal to the length of the corresponding simple pendulum, the measurement of this length, together with the observation of the time of vibration, is sufficient to determine the value of

* See Franklin and MacNutt, *Elements of Mechanics, Theory of the Reversion Pendulum*, pp. 142-144.

gravity. The experiment consists, therefore, in adjusting the positions of the two knife-edges by trial until the time of vibration about one pair as an axis is the same as that about the other.

The pendulum used consists of a hollow cylindrical bar, one end of which is loaded by a filling of lead (Fig. 34).* There are two pairs of knife-edges, one being placed near each end of the bar; both are capable of adjustment along the bar, so that the distance between them can be altered.

The method of the experiment is as follows:

(1) Fasten one pair of knife-edges to the bar at some point near the end which is not weighted.

(2) Determine the rate of vibration roughly by observing with a watch or clock the time occupied by some large number of oscillations (40-50).

(3) Locate approximately the position of the center of oscillation by hanging a simple pendulum (a small weight suspended by a cord) near by, and adjusting its length until it vibrates nearly in unison with the bar. The length of this simple pendulum is then a rough approximation to the distance from the center of suspension of the bar to its center of oscillation. To obtain this distance more accurately, set the second pair of knife-edges at a distance from the first equal to the length just determined; then *reverse* the bar, and determine its time of vibration as

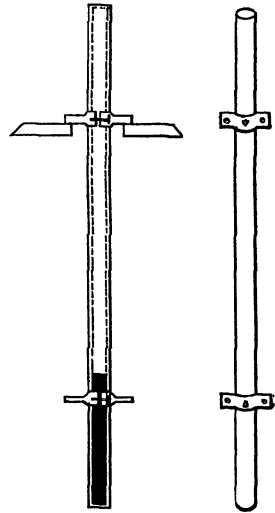

Fig. 34.

* The pendulum here referred to is a very simple one, but with careful observations is capable of giving quite accurate results. A homogeneous cylindrical bar is sometimes used, but with such a pendulum one pair of knife-edges will be at such a point that considerable variation of its position will produce but little change in the time of vibration. See Exp. E₃, and Fig. 35.

before. The period should now be nearly the same as at first. If the two periods differ, one or both of the knife-edges should be shifted until the time of vibration is very closely the same with either suspension.

(4) The final determination of the time of vibration must be made very carefully, by the method outlined in A_5 II, making computations to the fourth significant figure.

(5) Finally, the distance between the knife-edges is to be measured as accurately as possible. From this distance and the two times of vibration, the value of g is to be computed.

If the values of the periodic time obtained for the two positions of the pendulum vary by more than .2 per cent, the following equation, which may be obtained from two equations of the form of 104, is to be used : *

$$g = \frac{4\pi^2(R_1^2 - R_2^2)}{R_1T_1^2 - R_2T_2^2}. \quad (105)$$

R_1 and R_2 may be obtained with sufficient accuracy by balancing the Kater's pendulum on a horizontal bar to determine the position of the center of gravity, and measuring the distances from it to the knife-edges.

Tabulate data and results as in A_5 II and E_1 .

Addenda :

Answer addenda 1, 2, 3, and 4 of Experiment E_1 .

EXPERIMENT E_3 . Relation between the time of vibration and the position of the knife-edges in a uniform cylindrical pendulum.

In the equation for the physical pendulum given in the preceding experiment, everything is determined for any given pendulum except R and T . The object of this experiment is to show the relation which exists between these two variables.

To this end, fasten the knife-edges at one end of the bar, and determine the period of vibration by the method of A_5 II, making readings as directed in the note under that heading. Then shift

* Franklin and MacNutt, *Ibid.*

the knife-edges down the bar five or six centimeters, and determine the new period. Continue shifting the point of suspension and observing the period until the center of the bar is reached. Seven or eight different positions of the knife-edges should be used, and the distance of the knife-edges from one end of the bar should be carefully measured in each case. In determining the time of vibration, a stop-watch will be found of considerable

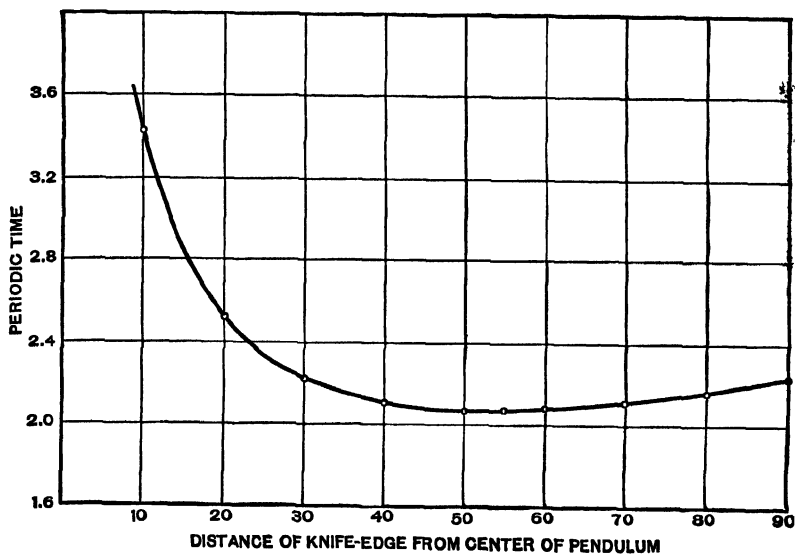

Fig. 35.

assistance, but a good watch whose "rate" is known will give satisfactory results. From the data obtained, plot a curve, similar to that given in Fig. 35, using for abscissas the distances of the point of suspension from the center of the bar, and for ordinates the corresponding times of vibration. Discuss and explain the shape of this curve, and determine the form of its equation from a knowledge of the law of the physical pendulum.

The following is a tabulated statement of a set of observations taken as indicated above. The results are shown graphically in Fig. 35.

RELATION OF PERIODIC TIME TO POSITION OF KNIFE-EDGES.

| Distance from Center of Gravity. | No. of Transit to Right. | Time. | Duration of 100 Oscillations. | Periodic Time. | Other Data and Results. |
|----------------------------------|--------------------------|---------------|-------------------------------|----------------|---|
| | | hr. min. sec. | | | |
| | I | 2 16 50 | | | |
| 90 | 101 | 20 30 | 220 | 2.21 | Length of bar = 183 cm. Diam. of bar = 2.5 cm. |
| | 201 | 24 12 | 222 | | Equation of curve from theory of pendulum : |
| | I | 29 00 | | | |
| 80 | 101 | 32 34 | 214 | 2.15 | $T^2R = \frac{4\pi^2}{g}R^2 + \frac{4\pi^2k^2}{g}$. |
| | 201 | 36 10 | 216 | | |
| | I | 42 00 | | | |
| 70 | 101 | 45 30 | 210 | 2.10 | From pairs of points on curve having equal ordinates. |
| | 201 | 49 00 | 210 | | |
| | I | 3 22 00 | | | |
| 60 | 101 | 25 27 | 207 | 2.07 | $T = 2.20, g = 970;$ |
| | 201 | 28 54 | 207 | | $T = 2.16, g = 989;$ |
| | I | 35 00 | | | $T = 2.12, g = 977.$ |
| 55 | 101 | 38 25 | 205 | 2.05 | |
| | 201 | 41 50 | 205 | | |
| | I | 51 40 | | | |
| 50 | 101 | 55 6 | 206 | 2.06 | |
| | 201 | 58 32 | 206 | | |
| | I | 4 6 30 | | | |
| 40 | 101 | 10 1 | 211 | 2.10 | |
| | 201 | 13 30 | 209 | | |
| | I | 17 10 | | | |
| 30 | 101 | 20 52½ | 222½ | 2.225 | |
| | 201 | 24 35 | 222½ | | |
| | I | 28 40 | | | |
| 20 | 101 | 32 54 | 254 | 2.535 | |
| | 201 | 37 7 | 253 | | |
| | I | 42 40 | | | |
| 10 | 101 | 48 24 | 344 | 3.435 | |
| | 201 | 54 7 | 343 | | |

Addenda to the report:

Answer addenda 1 and 2 in Exp. E₁ and

(3) From any pair of points on the curve compute the values of the constants of its equation, and hence determine the acceleration of gravity.

(4) Prove that the abscissa corresponding to the minimum ordinate is equal to the radius of gyration of the pendulum with respect to its center of gravity.

GROUP F: ELASTICITY.

(F_1) *Young's modulus by stretching*; (F_2) *Moment of torsion*;
 (F_4) *Young's modulus by flexure*; (F_5) *Impact*.

EXPERIMENT F_1 . Young's modulus by stretching.

Elasticity of tension is defined as the ratio of force applied to extension produced. If the elastic limit has not been reached, the extension of a weighted rod or wire is proportional to the force applied, and to the length; and is inversely proportional to the cross-section, or

$$l = E \frac{LF}{\pi r^2}, \quad (106)$$

in which E is the coefficient of elasticity. From this equation it is seen that E is the increase in length produced by unit force applied to a rod of unit length and unit cross-section.

Young's modulus is defined as the reciprocal of the coefficient of elasticity. Calling this modulus M , we have

$$M = \left(\frac{LF}{\pi r^2 l} \right) \quad (107)$$

Young's modulus may be computed if the quantities on the right of this equation are determined in the proper units.

The experiment consists of finding Young's modulus for two different wires, the elongations being measured by means of either a micrometer microscope or an optical lever. In either case the wires are suspended from a rigid support.*

Suspend from the end of the wire a weight which is just sufficient to take out the kinks; for a wire whose diameter is 1 mm. a weight of from two to four kilos will be required.

* If there is any reason to suspect that the support is not rigid, two microscopes must be used, one at the upper and the other at the lower end of the wire.

Microscope method. A microscope containing an eyepiece micrometer is now to be adjusted so that a slight scratch on the wire is sharply focused in the lower part of the field. As the tension of the wire is increased by the addition of weights, this mark will move across the field, and by means of the micrometer the elongation corresponding to each increment in weight can be measured. Measure in this way the elongations produced by successive increments in weight until ten elongations have been measured or the safe load limit of the wire has been reached. The limit of load on the wire is to be obtained from an instructor. Each increment in weight should be sufficient to cause an elongation of three or four scale divisions. Usually 1 kg. applied at a time will be sufficient change in load. *Make all settings in such a way as to eliminate back lash.*

After the wire has been fully loaded the weight is to be gradually reduced to the initial load and a new set of measurements made. Note whether equal increments of tension produce equal increments of length, and whether the elastic limit has been passed.

Determine the value of one division of the micrometer as described in Exp. A₄ III, and measure the length and diameter of the wire. Use a micrometer caliper to determine the diameter, noting the zero error of the instrument, making measurements at eight or ten places.

Since the square of the radius enters in the above equation, a small error in determining it will be relatively doubled in the computed value of the modulus. For this reason the diameter of the wire must be measured with unusual care.

If the first and last readings, the second and next to last, and so on, be used in a manner like that explained in A₅ II, for finding periodic times, an average value of the elongation per unit change of load may be obtained, giving equal weight to all the observations made. From these data compute Young's modulus.

The results are also to be shown by plotting curves in which

abscissas represent forces applied, and ordinates the increments in length produced.

These curves are to be discussed in the usual manner.

Optical lever method. This method of finding Young's modulus differs from the microscope method only in the method of determining the elongation. Computations and curves are to be obtained as explained above.

The optical lever consists of a light frame supported on three sharp pins and carrying a mirror which may be rotated, in a plane containing the points of two of the pins, about these points as an axis. In this experiment these two pins are supported on a fixed plane in a groove. The third pin is supported on the upper surface of a cylinder whose axis is the axis of the wire under investigation, to which the cylinder is clamped. Any change in tension in the wire moves the cylinder parallel to its axis, rotating the optical lever about its fixed axis. If the perpendicular distance R between the movable pin and the axis of rotation of the optical lever be known and the angle through which the plane of the points is rotated be also known, the elongation may be computed. When the angle is small, the elongation l will be equal to the product of the angle θ in radians and the distance R . The distance R is to be determined by pressing the points on paper and making the proper measurements.

The angle θ is to be determined by setting up a telescope with a horizontal cross wire and a vertical scale at a convenient distance from the mirror (not less than a meter) in such a position that the image of the scale may be seen in the telescope. The axis of the telescope should be approximately horizontal. The height of the telescope should be such that when half the maximum load is suspended from the wire, the scale number seen in the telescope is about on a level with the axis of the telescope. Make scale readings by means of the telescope for increasing and decreasing loads as indicated under the first method. Measure the distance from the mirror of the optical lever to the

scale, and compute values of θ . Remember that the beam of light reflected into the telescope moves through twice the angle that the mirror, and consequently the plane of the pins of the optical lever, moves through.

EXAMPLE OF METHOD OF FINDING L .

| | |
|---------------------------------------|-------------|
| Value of R | = 5 cm. |
| Dist. mirror to scale, d | = 100 cm. |
| Mean radius of wire, r | = 0.043 cm. |
| Length of wire under observation, L | = 148 cm. |

| Force producing Elongation in Kg Wt. | Scale Readings. | Differences in Readings for Indicated Loads. | $\tan 2\theta = \frac{\text{Diff.}}{100} = 2\theta$ (approx.). | θ per Kg Wt. | $l = R\theta$. |
|--------------------------------------|-----------------|--|---|---------------------|-----------------|
| 0 | 30.2 | 14-0 = 10.4 | 0.104 | 0.00743 | 0.0375 |
| 2 | 28.7 | 12-2 = 7.4 | 0.074 | 0.00740 | |
| 4 | 27.3 | 10-4 = 4.6 | 0.046 | 0.00767 | |
| 6 | 25.7 | 8-6 = 1.5 | 0.015 | 0.00750 | |
| 8 | 24.2 | | | 0.00750 | |
| 10 | 22.7 | | | | |
| 12 | 21.3 | | | | |
| 14 | 19.8 | | | | |

EXPERIMENT F₉. Determination of the moment of torsion of a wire.

When a wire of elastic material, such as steel, bronze, or hard-drawn copper, is twisted by a moderate amount, the moment of the couple by which it tends to regain its original condition is proportional to the angle of torsion; *i.e.* if θ is the angle, and L the moment of the elastic return force, $L = L_0\theta$. The constant L_0 is called the moment of torsion, and depends upon the length, diameter, and material of the wire.

To determine the value of L_0 , a heavy weight, of such shape that its moment of inertia can be readily computed, is hung upon the end of the wire, and set to vibrating through an angle of twenty or thirty degrees. Since the moment of the return force is proportional to the angular displacement, the weight

will have simple harmonic motion, and the vibration will be isochronous. From equation 87 we will have

$$L_0\theta = -K \frac{d^2\theta}{dt^2}, \quad (108)$$

in which $L_0\theta$ is the resultant moment due to torsional displacement through an angle θ , and $\frac{d^2\theta}{dt^2}$ is the angular acceleration of the suspended weight. An integration of this equation gives

$$T = 2\pi\sqrt{\frac{K}{L_0}}, \quad (109)$$

in which T is the period of the harmonic motion.

The same equation may be derived more easily from the energy relations. If δ is the maximum angular displacement, the kinetic energy of the rotating weight as it passes the mid-position will be

$$E_k = \frac{1}{2} K\omega_0^2 = K \frac{2\pi^2\delta^2}{T^2}. \quad (110)$$

The potential energy of the twisted wire, when the suspended weight is at its greatest displacement, is equal to the work that must be done on the wire to twist the lower end through the angle δ . The moment of the force at any instant to be overcome is $L_0\theta$; as this varies between 0 and $L_0\delta$, the average moment is $\frac{1}{2}L_0\delta$, and hence the work done and the potential energy gained is

$$E_p = \frac{1}{2} L_0\delta \cdot \delta. \quad (111)$$

As the dissipation of energy during a single vibration may be neglected, the potential energy at the extreme, when the weight has no motion, must be equal to the kinetic energy when the weight is at its mid-position and there is no twist in the wire. Hence we have

$$T = 2\pi\sqrt{\frac{K}{L_0}}.* \quad (112)$$

* For another proof of this equation, see Exp. E₁.

It is to be observed that since it is the square of T that appears in the formula, an error in the determination of the period will introduce a considerable error in the result.

To get the period accurately, proceed by method of $A_5 I$; but the following is given as the regular method of procedure (Exp. $A_5 II$).

Permitting the bob to rotate with an amplitude of about 15° , observe the transit to the right of some point on the bob past a marker of some sort on a stationary support. If the period is longer than 10 seconds, observe the time of the 1st, 6th, 11th, 16th, 21st, 26th, 31st, 36th, 41st, 46th, 51st, 56th, and 61st transits, otherwise take the 1st, 11th, 21st, 31st, ... 91st transits.

If the period is the same for a large and a small amplitude, then it must be true that the return torque due to the elasticity of the wire is proportional to the angular displacement. To test this point determine the period for an amplitude of about 90° .

Measure the diameter of the wire in eight or ten places, with a micrometer caliper; also determine its length. Find the diameter of the cylindrical weight, making several measurements. If the weight is *easily* detached (*i.e.* without unscrewing anything), take it off and determine its mass; otherwise the mass may be obtained from an instructor.

From the data taken, find L_0 and n from the equations

$$L = L_0 \theta = \frac{4\pi^2 K}{T^2} \theta = \frac{\pi r^4 n}{2l} \theta, \quad (113)$$

in which n is the *slide modulus* of the wire, r its diameter, and l its length.

From the result obtained for L_0 compute the force, both in dynes and in pounds, which would twist the wire through a complete revolution when acting at a distance of one centimeter from the center.

Addenda. (1) Define *moment of torsion*, *slide modulus*.

(2) Prove that the torsional pendulum has true simple harmonic motion. (The formulas for S. H. M. may be assumed.)

EXPERIMENT F₄. Young's modulus by flexure.*

A bar supported by two parallel knife-edges is subjected to a vertical force applied for convenience at a point midway between the supports. Along its upper surface it suffers compression and along its lower surface there is a tension. The compression and tension decrease from the surfaces inward to a neutral interior surface where neither exists.

The amount of deflection e depends upon the distance l between the supports, the depth d of the bar, its breadth b , the applied force f , and also on a constant k which depends on the material of the bar. The relation may be expressed by the following equation :

$$e = kf^{\alpha}l^{\beta}b^{\gamma}d^{\delta}. \quad (114)$$

It is the object of this experiment to determine the constant k and the exponents α , β , γ , and δ .

The apparatus consists of a heavy bed plate with sliding supports for the bar, an insulated carriage carrying a micrometer screw with which to measure deflections, a battery, and an electric bell or other current detector. The deflecting force is applied midway between the supports and the screw adjusted to a point just over the point of application of the force in order to measure the deflections.

Place the bar on the supports which have been adjusted to the desired distance apart. Suspend a kilogram weight from the center of the bar and adjust the position of the screw. Connect the battery to the current detector, the screw carriage, and the bed plate. Adjust the screw until it is in contact with the support carrying the weight as indicated by the detector. Use this reading as the reference point. Apply enough load to deflect the center of the bar at least one complete turn of the screw and take another reading. Then proceed as before until six readings have been made. In this case the only variables have

* See Ferry and Jones, Practical Physics, vol. 1, Exp. 27.

been the applied force and the total deflections. The above equation may therefore be written

$$e = C_f f^a, \quad (115)$$

in which C_f is a new constant including all the other constants for this case. The expression may be written

$$\log e = \log C_f + a \log f. \quad (116)$$

Such an expression may be written for each observation as

$$\log e_3 = \log C_f + a \log f_3.$$

$$\dots \dots \dots$$

$$\log e_6 = \log C_f + a \log f_6.$$

Taking the difference between two equations of the above form, we have

$$\log e_6 - \log e_3 = a(\log f_6 - \log f_3), \quad (117)$$

from which a may be readily computed. Use the observations in pairs to compute three values of a , taking observations 1 and 4, 2 and 5, 3 and 6.

Now determine the mean deflection per kg. for five other lengths of bar in the manner indicated above. In this case the only variables are the deflections and length, and therefore we may write expressions like the following:

$$e = C_l l^\beta \quad (118)$$

or

$$\log e = \log C_l + \beta \log l, \quad (119)$$

from which β may be determined.

Arrange the bars in a series of variable widths and constant depths, and then in a second series of variable depths and constant widths and find the deflections per kg.,* keeping the value of l constant in either series. Compute the values of γ and δ from these series in a manner similar to that already outlined.

* Do not overload the bars. Do not use values of l less than 70 cm. In finding β vary l by about equal amounts and not less than 10 cm. Tabulate data carefully so that it may be easily understood.

After α, β, γ , and δ have been determined, make four independent determinations of the constant k , one in each series. Express k rationally and compare with values given in tables.

Plot a curve for each series, using values of $\log e$ as ordinates and corresponding values of the logs of other variables as abscissas. Discuss the forms of these curves and their constants and get the values of α, β, γ , and δ from them.

EXPERIMENT F₅. Elastic and inelastic impact.

Impulse, momentum, and coefficient of restitution.

When a body is moving, it is said to have a certain quantity of motion or momentum. The momentum may be expressed quantitatively as equal to the mass of the body multiplied by its velocity,

$$M = mv. \quad (120)$$

If the velocity of the body be changed, its momentum is changed and the rate of change of momentum is equal to the force applied to produce it.

$$\frac{dM}{dt} = m \frac{dv}{dt} = F. \quad (121)$$

Equation 121 may be written

$$Fdt = m dv. \quad (122)$$

Integrating equation 122 gives

$$\int Fdt = \int m dv = m(u - v), \quad (123)$$

in which u and v are the initial and final velocities, respectively.

The first member of the equation, $\int Fdt$, is called an impulse.

If F is constant, then the impulse is Fit . Usually the force is a variable, and the time is not accurately and often not even approximately measurable. The impulse is therefore measured in terms of the change of momentum as is shown in equation 123. The case studied will be that of two bodies having direct central impact; that is, along the line joining their centers of

mass. When they collide, in general they will have the same velocity when the period of compression is just past and that of restitution is about to begin. Call this common velocity w . Let the masses be m_1 and m_2 , their velocities before impact u_1 and u_2 , and those after impact v_1 and v_2 , respectively.

At any instant the elastic forces acting on the two bodies during impact are equal and opposite (Newton's third law of motion); then

$$f_1 = -f_2. \quad (124)$$

$$f_1 = m_1 \frac{dv}{dt} = -m_2 \frac{dv'}{dt} = -f_2, \quad (124')$$

or
$$m_1 dv = -m_2 dv'. \quad (125)$$

Integrating over the whole time of impact,

$$m_1(u_1 - v_1) = -m_2(u_2 - v_2), \quad (126)$$

from which $m_1 u_1 + m_2 u_2 = m_1 v_1 + m_2 v_2$, (127)

which shows that the sums of the momenta before and after impact are equal, that is, that

$$\Sigma mv = \text{constant}. \quad (128)$$

Let the impact be considered in two parts, namely, impulse R_1 from contact to maximum compression when w is the velocity of both bodies, and impulse R_2 from maximum compression to separation. If the bodies were perfectly elastic, it would be expected that R_2 would equal R_1 , but as a matter of fact R_2 is less than R_1 . The ratio of R_2/R_1 is constant so long as the impact produces no permanent deformation. This constant is called the coefficient of restitution.

$$R_2/R_1 = e. \quad (129)$$

In the first impulse (R_1), remembering that $\Sigma mv = C$, that the bodies have equal velocities w at the end of the impulse, and that the impulse is measured by the change in momentum,

$$R_1 = m_1(u_1 - w) = -m_2(u_2 - w). \quad (130)$$

In a similar manner

$$R_2 = m_1(w - v_1) = -m_2(w - v_2), \quad (131)$$

from which

$$\frac{R_2}{R_1} = e = \frac{m_1(w - v_1)}{m_1(u_1 - w)} = \frac{-m_2(w - v_2)}{-m_2(u_2 - w)},$$

$$e = \frac{w - v_1}{u_1 - w} = \frac{w - v_2}{u_2 - w},$$

and

$$eu_1 - ew = w - v_1, \quad (132)$$

$$eu_2 - ew = w - v_2.$$

Subtracting the second of these last two equations from the first, we have

$$e(u_1 - u_2) = v_2 - v_1 \quad (133)$$

or

$$e = \frac{v_2 - v_1}{u_1 - u_2}. \quad (133')$$

For perfectly inelastic bodies $e = 0$, from which it is seen that $v_2 = v_1$; that is, both bodies have the same velocity after impact.

Although the momentum after impact is equal to momentum before impact there is a loss of kinetic energy during impact, due to internal work on the bodies, the energy of motion changing into heat energy.

The loss in kinetic energy E_K' is given by the following equation:

$$E_K' = \frac{1}{2} m_1 u_1^2 + \frac{1}{2} m_2 u_2^2 - \frac{1}{2} m_1 v_1^2 - \frac{1}{2} m_2 v_2^2 \quad (134)$$

$$= \frac{1}{2} m_1 (u_1^2 - v_1^2) + \frac{1}{2} m_2 (u_2^2 - v_2^2) \quad (135)$$

$$= \frac{1}{2} m_1 (u_1 - v_1)(u_1 + v_1) + \frac{1}{2} m_2 (u_2 - v_2)(u_2 + v_2). \quad (136)$$

Now $R_1 + R_2 = R =$ total impact, and adding (130) and (131),

$$R = m_1(u_1 - v_1) = -m_2(u_2 - v_2). \quad (137)$$

Substituting in (136), we have

$$E_K' = \frac{1}{2} R(u_1 + v_1) - \frac{1}{2} R(u_2 + v_2) \quad (138)$$

$$= \frac{1}{2} R[(u_1 - u_2) - (v_2 - v_1)]. \quad (138')$$

Substituting in (138') the value of $v_2 - v_1$ from (133) gives

$$E_K' = \frac{1}{2} R(u_1 - u_2)(1 - e). \quad (139)$$

If the values of v_1 and v_2 obtained from (137) be substituted in (133), then

$$R = \frac{m_1 m_2}{m_1 + m_2} (u_1 - u_2)(1 + e). \quad (140)$$

Substituting (140) in (139),

$$E_K' = \frac{1}{2} \frac{m_1 m_2}{m_1 + m_2} (u_1 - u_2)^2 (1 - e^2). \quad (141)$$

The percentage loss l of kinetic energy is (141) divided by the initial kinetic energy

$$l = \frac{E_K'}{\frac{1}{2} m_1 u_1^2 + \frac{1}{2} m_2 u_2^2}. \quad (142)$$

In the case of inelastic impact when m_2 is initially at rest (the case in the first part of the experiment), u_2 and e are zero and (142) reduces to

$$l = \frac{m_2}{m_1 + m_2}; \quad (143)$$

when m_2 is stationary for elastic impact but free to move, $u_2 = 0$

and

$$L = \frac{1}{2} \frac{m_1 m_2}{m_1 + m_2} u_1^2 (1 - e^2), \quad (144)$$

$$l = \frac{L}{\frac{1}{2} m_1 u_1^2} = \frac{m_2}{m_1 + m_2} (1 - e^2). \quad (145)$$

If m_2 is not only at rest, but is very large compared to m_1 , then

$$\frac{m_2}{m_1 + m_2} = 1, \text{ approximately,}$$

and

$$l = 1 - e^2. \quad (146)$$

The following experiment is divided into two parts, I dealing with inelastic impact and testing equations 128 and 143; and II dealing with elastic impact and testing equations 128, 145, and 146.

I.

Inelastic impact.

A suspended lead cylinder is struck by a suspended lead ball, the contact surface being covered by a small amount of soft wax. After impact they travel along together as one body, e being zero. The cylinder pushes a light index along a metal arc graduated in degrees.

Adjust the suspensions until after impact the two masses move along the arc without wobbling. Make some preliminary trials to find the position of the index at the end of the path. Place the index nearly out to this point, draw the ball back to some known position, and let it fall along the arc. The ball may be held in place by a thread. When ready to make a reading, burn the thread. This method reduces wobbling.

Make the following readings: the position a of the center of the ball before falling; its position b when vertically beneath the support, the cylinder having been drawn out of the way, and its position g when just in contact with the cylinder in its position of rest; the position c of the index when just in contact with the forward side of the cylinder when free, its position d when the ball and cylinder are in equilibrium and in contact, and the reading f of the index at the end of the swing.

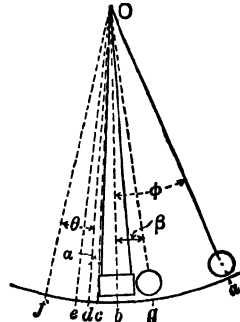

Fig. 36.

The arc \overline{cd} represents the difference between the position of the center of gravity of the cylinder alone and the new center of gravity of the system composed of the ball and cylinder. Twice this distance, \overline{ce} , is that which is not effective in carrying the index to f .

The effective fall of the ball is that measured along the arc $\overline{ab} - \overline{bg}$, and the resultant rise is measured by the arc $\overline{df} - \overline{de}$. Let the arcs \overline{ab} , \overline{df} , \overline{dc} , or its equal \overline{dc} , and \overline{bg} subtend the angles ϕ , θ , α , and β , respectively. Then the velocity of the ball immediately before impact and that of the system at the beginning of the resultant rise may be expressed in terms of ϕ , θ , α , β , and the radius r . Based on the equation

$$v = \sqrt{2gh}, \quad (147)$$

we have

$$u_1 = \sqrt{2gh_1} = \sqrt{2gr(\cos \beta - \cos \phi)},$$

and

$$v_2 = \sqrt{2gh_2} = \sqrt{2gr(\cos \alpha - \cos \theta)}.$$

Using the values of u_1 and v_2 thus determined, find the momenta before and after impact and compare them. Determine the per cent loss of kinetic energy and compare it with that computed, using equation 143.

Make three different sets of readings, using different initial positions of the ball B .

II.

Elastic impact.

In the case of elastic impact two steel balls are used, and two indices. One index is operated by the small ball, having a longer projection with which to engage the wire frame on the lower side of the ball. The shorter index is operated by the impinging ball.

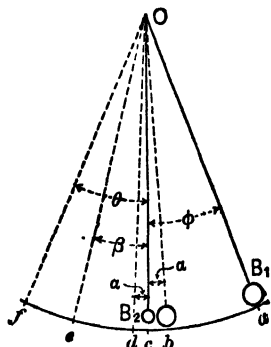

Fig. 37.

In this case the values of u_1 , v_1 , and v_2 are determined as in the previous case. The value of α is determined by holding B_1 just in contact with B_2 in its equilibrium position. Note that the balls do not travel together after striking. With this fact in mind derive

formulas for u_1 , v_1 , and v_2 , and from these find the values of the momenta before and after impact. Find also the per cent loss in kinetic energy and the value of e .

Make three determinations, two with the large sphere as B_1 and one with the smaller sphere as B_1 . In the latter case but one index can be used since the small ball will rebound. Much care is needed to make the reading of rebound in this case, so make several trials.

Find the masses of all the balls and cylinders used. Measure the values of r . Be very careful to take all necessary data and tabulate them carefully.

CHAPTER II.

GROUP G: DENSITY.

(G) *General statements; (G₁) Specific gravity of solids and liquids by the specific gravity bottle; (G₂) Determination of density with corrections for air displacement and temperature; (G₃) Nicholson's hydrometer; (G₄) Fahrenheit's hydrometer; (G₅) Density of a liquid by Hare's method.*

(G) **General statements concerning specific gravity and density.**

The specific gravity of a substance is the ratio of the weight of a given volume of the substance to the weight of an equal volume of water at its maximum density.

Specific gravities being ratios of like quantities are abstract numbers, and hence the same for all systems of units. The unit used in comparing the weights may indeed be entirely arbitrary, such as the unit extension of a spring made use of in the Jolly balance.

The density of a substance is the ratio of the mass of a given volume of the substance to the volume which it occupies; or in symbols

$$D = \frac{M}{V}. \quad (148)$$

Since density is not an abstract number, its numerical value in any particular case must depend upon the units used. For example, the density of water in the foot-pound-second system is $62\frac{1}{2}$. The density of water in the C. G. S. system is unity, for the reason that the unit of mass is equal to the mass of a cubic centimeter of water. Hence it follows that the densities

of all substances in the C. G. S. system are numerically equal to their specific gravities. This is not *absolutely* true, however, for the mass of a cubic centimeter of water at its maximum density is not exactly a gram.

The term "relative density" is sometimes used. It has the same meaning as "specific gravity."

A few methods for finding specific gravity are outlined in experiments which follow.

EXPERIMENT G₁. **Specific gravity of solids and liquids by the specific gravity bottle.**

The specific gravity bottle is simply a small bottle which is provided with an accurately fitting ground-glass stopper. A very small hole through the center of this stopper leads to the interior of the bottle, its object being to permit the bottle to be *completely* filled with any liquid.

To use the specific gravity bottle, proceed as follows :

I.

Specific gravity of a liquid.

First weigh the bottle alone, when perfectly clean and dry. Next fill with distilled water and weigh again. Finally fill the bottle with the liquid whose density is required, and weigh a third time. These three weights are sufficient for the computation of the specific gravity.

II.

*Specific gravity of a solid.**

Place the substance in the specific gravity bottle and determine the combined weight. Then add sufficient distilled water, to entirely fill the bottle, insert the glass stopper, and after wiping off any drops which may adhere to the outside, weigh again. Finally determine the weight of the bottle when filled with

*The specific gravity bottle is especially useful when the solid is in the form of small fragments or powder.

water alone. These three weights, together with the weight of the bottle, are sufficient to determine the specific gravity of the substance. This method is, of course, only available when the substance is insoluble in water. In the case of soluble substances some liquid of known density must be used in which the substance does not dissolve.

It sometimes happens that difficulty is met with in shaking off the small bubbles of air which tend to adhere to the substance, and which will introduce a considerable error. In such cases the bottle containing the substance, and about half full of water, should be placed under the receiver of an air pump, and the air exhausted until bubbles are no longer formed.

If greater accuracy is required, corrections for temperature and air displacement must be made, similar to those described in Exp. G₃.

Find the specific gravity of two liquids and one solid. Weighings are to be made by the method of vibrations as described in Exp. A₆ II.

EXPERIMENT G₂. Precise determination of density, by weighing in air and in water.

The balance is nearly always used for comparing masses, but it should be remembered that it is merely a lever with equal arms, by which two *forces* may be proved to be equal. Each of the two equal forces is the resultant of the *weight* of the body on the scalepan acting *downwards*, and the buoyant effect of the weight of the fluid displaced by the body acting *upwards*. This gives

$$W_1 - w_1 = W_2 - w_2.$$

Since weights are directly proportional to masses, we have

$$M_1 - m_1 = M_2 - m_2, \quad (149)$$

in which M_1 and M_2 are the masses of the bodies on the two scalepans, and m_1 and m_2 are the masses of the displaced fluid in the two cases. Nearly always in using the balance, m_1 and

m_2 are supposed to be equal, or at least it is assumed that their difference is negligible.

If M_s is the mass of the substance of density δ_s , then from the definition of density the volume of the displaced fluid will be $\frac{M_s}{\delta_s}$. If δ_a is the density of the displaced air, then its mass is $M_s \frac{\delta_a}{\delta_s}$. If M is the mass of the counterpoise, and δ_c its density, equation 149 becomes

$$M_s - M_s \frac{\delta_a}{\delta_s} = M - M \frac{\delta_a}{\delta_c}. \quad (150)$$

In order to determine M_s from the known mass of the counterpoise, δ_a , δ_s , and δ_c must be known. Approximate values for these quantities will serve quite as well as more accurate values, because the term in which they appear is always a very small quantity.

The object of this experiment is to determine the density of the substance s with all possible accuracy. If the substance is suspended from the scalebeam, so as to be immersed in water of density ρ , and is then counterpoised with the mass M' , equation 149 becomes

$$M_s - M_s \frac{\rho}{\delta_s} = M' - M' \frac{\delta_a}{\delta_c}. \quad (151)$$

If equation 150 be divided by 151, and the resulting equation solved for δ_s , we shall have

$$\delta_s = \frac{M}{M - M'} (\rho - \delta_a). \quad (152)$$

In deriving equation 152 it has been assumed

(1) That the density of the counterpoise M is the same as that of M' .

(2) That the density of the air has not changed between the two weighings.

(3) That the density of the substance or of the weights has not been changed during the experiment on account of expansion. The value of ρ depends on the temperature of the water. The value of δ_a depends on the temperature, pressure, and

humidity of the atmosphere at the time of performing the experiment. The effect of humidity in altering the density of the air may be neglected except when the substance weighed is a gas or a vapor.

Use the most accurate balances that are available, counterpoise the substance whose specific gravity is required, first in air, and then when suspended by a fine wire, in distilled water. Observe also the temperature of the water and the temperature and barometric pressure of the atmosphere. The distilled water used should first be thoroughly boiled in order to expel the dissolved air.

The values of ρ for different temperatures can be found in most reference books, while δ_a can be computed from the temperature and pressure of the air.*

In this experiment all observations must be taken with great care. A suitable correction should be made for the weight of the wire used in suspending the substance in water, and all air bubbles that may adhere to the wire or specimen must be carefully removed.

When the value of δ_s is finally obtained, it must be remembered that this is the density of the substance at the temperature of the water in which it was weighed. For comparison, this must be reduced to 0° by using the coefficient of cubic expansion.

EXPERIMENT G₃. Specific gravity by Nicholson's hydrometer.

This hydrometer consists of a hollow cylinder which is made to float with its axis vertical by means of a heavy weight at the bottom. At the top a wire projects two or three inches above the end of the cylinder and supports a small scalepan. At the bottom another pan is provided, upon which can be placed the object whose density is required. In the instrument shown in Fig. 38, which is a slight modification of the hydrometer of Nicholson, this mark consists of the point of a wire which projects downward from the center of the scalepan.

* Tabulated values of ρ and δ_a will be found in Landoldt and Bornstein, in Stewart and Gee, vol. 1, etc.

To determine the specific gravity of a solid, place the hydrometer in water, and find by trial the weight which must be placed on the scalepan in order to bring some well-defined mark to the surface of the water. Then place upon the scalepan the body whose density is required, and add weights until the instrument has sunk again to the same level. Finally place the body upon the lower pan or basket, and again determine the weight necessary to sink the hydrometer. From these three weights the specific gravity can be computed. In case the specimen is lighter than water it must be fastened in some way to the bottom of the instrument to prevent it from float-

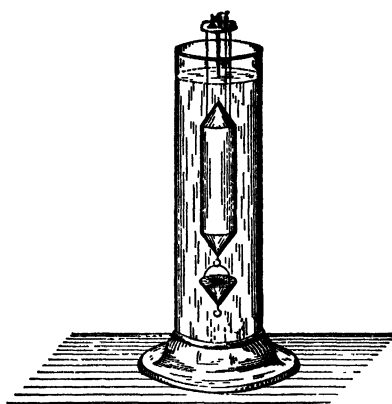

Fig. 38.

ing away. The instrument may also be used in determining the specific gravity of a liquid.

This form of hydrometer is not very sensitive, and therefore cannot be expected to give results of great accuracy. In this experiment, however, as in all specific gravity determinations, the most common source of error is the presence of air bubbles, which will adhere both to the specimen and to the instrument unless carefully shaken off.

The report should contain a full explanation of the principles involved, including Archimedes' law.

EXPERIMENT G₄. Fahrenheit's hydrometer.

This hydrometer consists of an elongated glass bulb (Fig. 39), weighted at the bottom, and carrying at the top a small scalepan supported by a wire sealed into the bulb.

To determine the density of a liquid, first float the instrument

in distilled water and place weights on the scalepan until some well-defined mark on the stem is brought to the surface of the water. It will be found preferable to use bits of tin foil for weights. The tin foil corresponding to each separate observation should then be wrapped in a piece of paper, labeled, and afterwards weighed on a pair of balances. Then place the hydrometer in the liquid whose specific gravity is required and determine the weight necessary to sink it to the same point. From these two weights, together with the weight of the hydrometer, the specific gravity of the liquid can be computed. A correction should be made for the temperature of the water.

Use the instrument in the manner just described to determine the variation in the density of a salt solution as its degree

of concentration is altered. To accomplish this, first dissolve in water sufficient salt to make a 20 per cent solution, weighing both the salt and the water. Having determined the density of this solution, dilute it by the addition of a known weight of water, and again determine its density. Continue in this way until the solution is so dilute as to have nearly the same specific gravity as water. At least eight or ten different observations should be taken. With the results obtained, plot a curve in which the strengths of the solution are used as abscissas and the corresponding densities as ordinates.

In making the various solutions use water at room temperature and let the solution when changed come to room temperature, before making readings. A Nicholson's hydrometer may be used in this experiment in the same manner as the Fahrenheit instrument. See Exp. G₃ for description.

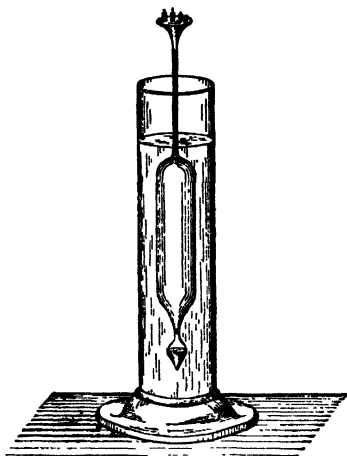

Fig 39

EXPERIMENT G₅. Density of a liquid by Hare's method.

The apparatus used in this experiment consists of two vertical tubes open below and connected above to a common tube; the latter tube is provided with stop cock (see Fig. 40). The two tubes dip into separate vessels, one containing distilled water, and the other the liquid whose density is to be determined. The tubes are fastened to an upright board on which there is a scale.

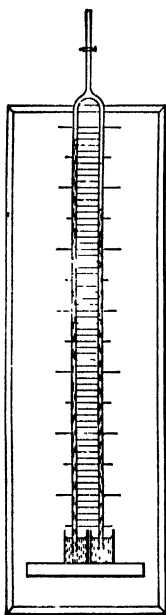

Fig. 40.

If the pressure of the air in the common tube is reduced by suction, the liquid will rise in each tube, the heights of the two columns being inversely proportional to the densities of the liquids used.

This may be demonstrated as follows: Let a be the atmospheric pressure, b the pressure of the air in the common tube above the two columns of liquid, both measured in dynes per square centimeter. Let h , h' , and δ , δ' be the heights and densities of the two columns of liquid. From Pascal's law we have for any point within the first tube on a level with the surface of the liquid in the open vessel

$$a = b + h\delta g, \quad (153)$$

and for the corresponding point within the second tube

$$a = b + h'\delta'g.$$

$$\therefore h : h' = \delta' : \delta.$$

The student is to perform either part (a) or part (b) as instructed.

(a) Put distilled water into one of the vessels, and the liquid whose density is to be determined into the other. By suction cause the liquids to rise in the tubes until the top of the highest column is near the upper end of the scale. Adjust the level

of the liquid in each vessel until it is at the zero of the scale, and read the heights of the two columns. Then open the stop cock until the columns have fallen through 8 or 10 cm. Adjust as before, and again read the height of each column. Repeat these readings for several different heights.

Compare in this way the densities of four different liquids with that of distilled water, and also two of the liquids with a third. Compare the ratio of the densities thus determined with those determined by comparison with distilled water. The tubes should be rinsed with distilled water *before* and *after* using each different liquid.

Plot curves for each set of data taken. When distilled water is used as a standard of comparison, use values of the heights of the water column as abscissas, and corresponding differences in heights of the liquid tested and the water column as ordinates. In the cases where two of the liquids are compared with a third use heights of the third liquid as abscissas and corresponding differences in heights of the liquids compared as ordinates. Interpret the curves and obtain all the possible physical constants from them.

(*b*) Make up a 20 per cent solution of the material supplied, using distilled water as a solvent, and use as directed in part (*a*) above. Repeat the experiment with five other known concentrations of the solution, diluting with the proper amounts of distilled water to give solutions varying by approximately 3 or 4 per cent. Note the temperature in all cases.

Plot six curves, one for each concentration, using heights of the distilled water column as abscissas and corresponding differences in solution and water heights as ordinates.

Plot one curve, using concentrations of the solutions as abscissas and corresponding densities as ordinates.

Interpret the curves and find the possible physical constants from them.

GROUP H: PROPERTIES OF GASES.

(H₁) *Verification of Boyle's law*; (H₂) *Comparison of the cistern barometer and the siphon barometer*; (H₃) *Pressure of saturated vapors.*

EXPERIMENT H₁. Verification of Boyle's law.

The apparatus consists of two glass tubes mounted vertically upon some suitable support and connected at the bottom. One tube is left open at the top, while the other can be closed so as to be air-tight. Both are provided with scales to enable the height of the mercury contained in them to be measured, or a common scale may be provided.

I.

To test the law for pressures greater than one atmosphere.



Fig. 41.

For this purpose the closed tube should be considerably shorter than the other, if the tubes are fixed in position and the level of the mercury is adjusted by means of a cistern whose height may be varied. If both tubes are adjustable in height and connected by a rubber tubing, as shown in Fig. 41, they may be of the same length. In this experiment the tubes are not supposed to be graduated in cubic centimeters, but the cross section of the closed tube is supposed to be known so that volumes may be computed. Near the top of the closed tube, just below where the contraction begins, there should be a reference mark. Above this mark the volume may be unknown, but it is constant. The volume below this mark above the mercury surface may be computed from the readings and known cross section.

Adjust the positions of the two tubes well down on their supporting rods with both tubes open to the air, so that the mercury is near the bottom of the tube that is to be closed and near the top of the open tube.

Close the stop cock on the closed tube and read the positions of the mercury surfaces and the mark near the top of the closed tube on the common vertical scale. Raise the open tube through about one tenth of its range and make another set of readings on the mercury surfaces and the reference mark on the closed tube, waiting sufficient time for the temperature to become constant. One or two minutes will usually be sufficient. If the closed tube is not to be moved, the first reading made on the reference mark near its top will be sufficient for this part of the experiment. Continue to make reading in the manner just described until ten readings have been made. Then gradually reduce the pressure on the air within the closed tube to atmospheric pressure by lowering the open tube, going down in five steps.

In each of the observations above, the total pressure to which the air in the closed tube is subjected is measured by the difference in level between the two columns of mercury *plus* the pressure of the atmosphere. In tabulating the results each difference in level should therefore be increased by the height of the barometer at the time of the experiment.

If the tube containing the air is of uniform cross section, the volume of the confined air is proportional to the length of the tube. In this experiment it is sufficiently accurate to assume the tube to be uniform, except at the closed end, where the cross section is apt to be irregular. If l is the difference in height of the mercury in the closed tube and the reference mark near its closed end, and V_0 the unknown volume of that portion of the tube above that mark, then the total volume is $V = V_0 + lA$, in which A is the cross section. If Boyle's law is true, we should have $PV = K$; or $P(V_0 + lA) = K$. With the exception of P and l , all the quantities in this equation are constant. If a curve is plotted with the observed values of l as abscissas and the corresponding values of $1 + P$ for ordinates, this curve should therefore be a straight line. Determine the equation of this line by the method of least squares, and from

this equation compute the values of V_0 and K . Reduce both quantities to C. G. S. units. Apply the method of least squares to the ten observations made for increasing pressures. It is necessary to use great care in the computations, carrying them to four significant figures. The cross section A is to be obtained from an instructor. The atmospheric pressure is to be read by the student on a barometer in the laboratory, and the temperature of the air noted.

II.

To test the law for pressures less than one atmosphere.

Adjust the positions of the two tubes near the tops of their rods, the stop cock of the closed tube being open, so that the mercury about half fills the closed tube and is as low as possible in the open tube. Then close the stop cock and make readings on the mark near the top of the closed tube and the mercury surfaces. Then lower the closed tube through about one fifth of its range and proceed to make readings as in part I. Make five readings down and five more on the return. Make computations as in case one, omitting the work using least squares. In general the values of K obtained in the two cases will not agree. Explain this difference.

If more accurate results are desired, the short tube must be calibrated by means of mercury,* and the air used must be carefully dried. In all cases great care must be taken to keep the temperature of the air constant.

The student will find it interesting to compute the constant k in the equation $\frac{PV}{\theta} = k$, which is true for a perfect gas at all temperatures. If this is done, the results should be put in such a form as to refer to the volume and pressure of *one gram* of air. It will then be possible to compare the value computed for k with those given in various reference books, and a check on the results of the whole experiment is obtained.

* See Stewart and Gee, vol. 1.

EXPERIMENT H₂. Comparison of a cistern barometer and a siphon barometer.

The apparatus for this experiment consists of two barometers of the types indicated above, an accurate vertical scale divided to millimeters, and a reading telescope mounted upon a vertical rod. The length of this rod should be at least 80 cm., and the vertical scale should be of the same length. It is essential that the telescope turn freely upon its support with an accurately horizontal motion.

The arrangement of the apparatus which is shown in Fig. 42 is as follows:

The two barometers are mounted side by side upon a substantial block. At points *a* and *b*, situated in positions equally distant to the right of barometer *B*₁ and to the left of barometer *B*₂, are pins from which the scale *S* may be suspended. The latter must be adjusted beforehand so

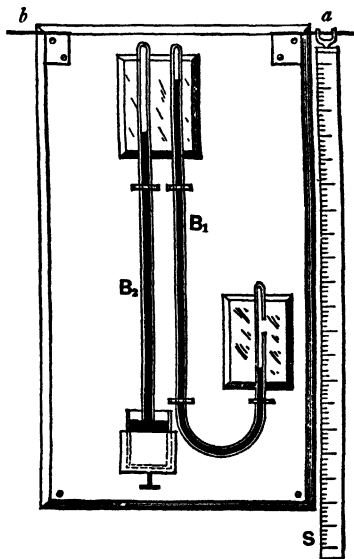

Fig. 42.

that when the Λ -shaped opening is placed on either pin, the scale will swing freely into a vertical position.

The reading telescope should be set up at as small a distance from the barometers as the length of the drawtube will permit, and should be in such a position that the meniscus of either mercury column can be seen, and also the scale, in good definition, without change of focus.

These adjustments having been completed, the following observations are to be made:

(1) *Scale hanging at the right.*

(a) The telescope is focused upon the upper meniscus of

barometer B_1 (siphon), and the distance from the cap of the meniscus to the fixed cross-hair in the eyepiece is measured by means of a micrometer.*

(*b*) The telescope is then swung to the right until the vertical scale comes into the field. (In case the scale is not in proper focus, further adjustment must be made by moving it towards or away from the telescope, and not by focusing the latter.)

(*c*) The scale divisions nearest the fixed cross-hair are identified and noted, and their distances from the latter are measured by means of the micrometer screw.

(*d*) These operations are repeated in the case of barometer B_2 (cistern).

(2) *Scale hanging at the left.*

(*e*) The various operations described as *a*, *b*, *c*, and *d* are carefully repeated.

(*f*) The telescope is shifted to a position opposite the cistern of barometer B_2 , and the level of the mercury in the same is obtained by readings similar to those described under *a*, *b*, and *c*.

(*g*) The level of the lower meniscus or barometer B_1 is determined as above.

(3) *Scale hanging at the right.*

(*h*) The levels of cistern and lower meniscus are redetermined as above.

(4) *The reading of a thermometer placed midway between the two mercury columns is noted.*

If the conditions indicated in the description of this experiment are fulfilled, that is to say, if the scale hangs vertically both at the right and left, and the telescope moves smoothly in a nearly horizontal plane, the height of mercury column (B_1 and B_2 respectively) will be found nearly the same, whether com-

* In case the reading telescope is not provided with a micrometer eyepiece the common eyepiece should be furnished with a suitable ruling on glass, which, placed in the focus, makes a very good substitute.

puted from readings with scale left or scale right. Any discrepancy approaching 0.01 cm. should indicate the advisability of repeating the measurements. The height of the two mercury columns in B_1 and B_2 will, however, differ very appreciably, even when the vacuum is good in both instruments. The difference is due to depression by capillary action, which influences the cistern barometer only. The next step is to determine whether the correction for capillarity will account for the difference of barometric height.

(5) *To calibrate the cistern barometer for capillarity*, note the reading of the meniscus when the screw by means of which the height of the mercury in the cistern* is adjusted, is at almost its lowest position; then add a weighed quantity of pure mercury to the cistern sufficient to produce a rise of about one centimeter in the surface of the contents. The meniscus will rise through a distance precisely corresponding to the change of level in the cistern, and in case the ratio in the cross sections be not very large indeed, the change of level as compared with that which would have occurred had there been no loss of mercury from the cistern to supply the increase in the column within the barometric tube, will afford a fair approximation to the diameter of the latter. This determination involves the measurement of the dimensions of the cistern and the computation of its contents per centimeter of vertical height.

In case the difference in the observed height for B_1 and B_2 is not entirely accounted for by means of the correction for capillarity (concerning which see any one of the larger treatises in physics), it is probable that the vacuum in one or both barometers is imperfect. Gross errors of filling may be detected by driving the column of B_2 to the top of the tube, by means of the screw, and watching for a bubble which cannot be made to disappear by pressure, and, in the case of the siphon barometer,

* The cistern barometer to be used in this experiment should be provided with a cistern which has a flexible leather bottom, upon which a screw impinges as in the Fortin barometer, giving considerable range of level.

reaching the same end by the direct application of pressure to the open end of the tube.

To reduce the readings obtained in this experiment to absolute measure,* the scale should be placed upon the dividing engine, and compared with some good standard of length, or with the screw itself, if the constant of the instrument is known.

EXPERIMENT H₃. Vapor pressure of saturated vapor.†

When a vapor is in contact with its liquid in an inclosed space, there will be a pressure exerted by that vapor which depends only upon the temperature and consequently not at all upon the volume which the vapor occupies. If the temperature be raised, liquid will evaporate until the pressure of the vapor has risen to a new value corresponding to that for the given new temperature. If the temperature is lowered, then the vapor pressure will be too high for the new temperature, and enough vapor will be condensed to lower the vapor pressure to that corresponding to the lower temperature. If at a given temperature the volume be increased, the first effect will be to lower the pressure, but immediately evaporation begins to take place and will continue to do so until enough liquid has been vaporized to bring the vapor pressure back to its original value. If under like circumstances the volume be decreased, the converse of the above will take place.

This experiment is one to determine the vapor pressure of a saturated vapor. The vapor is trapped over mercury in a sealed tube. By the side of this sealed tube is another tube containing mercury at the barometric height. Surrounding the whole is a water jacket in which there is a spiral coil of wire by means of

* The apparent height of the barometer depends upon the temperature. To find the true height it is therefore necessary to make correction for the density of the mercury and the length of the scale used, as both of these factors depend on temperature. It is frequently desirable to reduce the readings to sea level at a given latitude since the value of g varies from point to point on the earth's surface. For methods of making corrections for the above see Kohlrausch, *Physical Measurements*, pp. 76-78, and Edser's *Heat for Advanced Students*, pp. 23-27.

† Reference: Edser's *Heat for Advanced Students*, pp. 94-95, 102-104, 220-224.

which the temperature of the water may be raised when a current of electricity is sent through the wire. Connect the spiral coil in series with a resistance, a key for making and breaking circuit, and a 55-volt alternating E. M. F., leaving the circuit open. Then fill the water jacket with ice water by means of the circulation pump attached to the apparatus. After having caused the water to circulate for a few minutes to bring the vapor to the temperature of the water, make a reading on the top of the mercury column in each tube, by means of the sliding index and scale, taking care to eliminate parallax. Read the temperature by means of the thermometer suspended within the water bath. Close the circuit and allow current to flow for sufficient time to raise the temperature of the bath about 10° , stirring continuously by means of the pump. Open the circuit, but continue the pumping so that the water and the vapor may take approximately the same temperature. Make another set of readings, as noted above. Continue this operation at intervals of 10° , approximately, until the limits of the apparatus have been reached or the water is about 80° C. Make a scale reading on the upper end of the inside of the vapor tube.

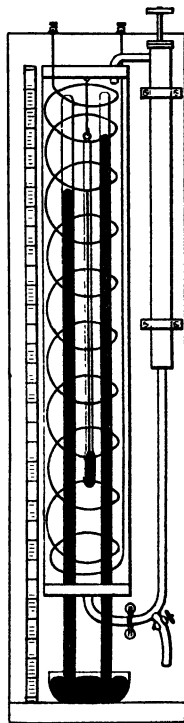

Fig. 42 a.

Plot a curve, using as abscissas the temperature in centigrade degrees and as ordinates the differences of reading on the two mercury columns. These differences give approximately the vapor pressures of the liquid. This method neglects the change in density of the mercury due to change in temperature and also the depression due to the small quantity of liquid.

The pressure readings may be reduced to 0° C. by using the expression

$$h = h_0(1 + \beta t), \quad (154)$$

in which h is the observed height at a temperature t , β is the volume coefficient of expansion of mercury, and h_0 is the height of the column at 0° C. This correction will usually be less than 1 per cent, on account of the comparatively small range of temperature used or within the errors of observation, and need not be made.

In order to compare the action of a saturated vapor at different temperatures with a perfect gas, two more curves are to be drawn, one for the saturated vapor and the other for an ideal gas, using the products $p v$ as ordinates and corresponding values of the absolute temperature θ as abscissas. The curves are to be plotted on the same sheet to the same scale from the same origin. The true origin $\theta = 0$ for the x -co-ordinates may not appear on the sheet, so that the curves may be shown to a better scale.

Remembering that the volume v of the vapor is proportional to the length of the tube above the surface of the liquid, the cross section being constant, the products $p l$ and θ may be used as co-ordinates instead of $p v$ and θ . Find the products $p l$, and plot such a curve for the saturated vapor.

To get data for the curve for a perfect gas assume the perfect gas to occupy the same volume and to be at the same temperature and pressure as the saturated vapor at the highest temperature used in the experiment. The following relation holds for the perfect gas,

$$p l = C \theta, \quad (155)$$

in which l is proportional to volume, as noted above. Find the value of C for the perfect gas. C being a constant, it can be used for any other temperature. Taking the lowest temperature used in the experiment and C as obtained above, compute the final product $p l$ at the corresponding temperature. Since the line is a straight line, connect these two points. This will give the line representing the change for a perfect gas starting with the same final conditions as with the saturated vapor.

Compare the two curves and discuss some causes for the difference between them.

CHAPTER III.

GROUP I: CALORIMETRY.

(I) *General statements ; (I₁) Heat of vaporization ; (I₂) Heat of fusion ; (I₃) Specific heat ; (I₄) Radiating and absorbing power ; (I₅) Joule's equivalent.*

(I) General statements concerning calorimetry.

It may be said in general that calorimetric determinations are subject to a great variety of annoying errors, which can be avoided only by the exercise of especial care and patience on the part of the experimenter. The student is therefore advised to plan his work very carefully before beginning the experiment itself, so that he will run no risk of omitting essential observations and precautions. It will generally be found that the greatest source of error in calorimetric experiments is the inaccurate determination of temperatures. This may be due to several causes :

(1) The thermometer may indicate the temperature of a *portion* of the liquid, the rest of the liquid being at a different temperature.

(2) The thermometer may not have had time to acquire the temperature of the surrounding liquid.

(3) The thermometer itself may be inaccurate.

(4) The reading of the thermometer may be at fault.

These sources of error should be guarded against with especial care.

The equations required for the computation of results in calorimetry may all be derived from one general principle. This principle may be stated as follows: The amount of heat lost by one system of bodies is equal to the amount gained by

another system. This, of course, treats as potential energy the amount of heat necessary to produce changes of state. The heat lost or gained by a body may be due to two causes :

(1) Change in temperature ; the amount in this case is equal to the continued product of the mass, specific heat, and change in temperature of the body.

(2) Change of state ; this amount is equal to the product of the mass so changed by a constant quantity of heat necessary to produce such a change in unit mass.

The amount of heat lost by radiation to the air cannot be expressed in either of these ways ; but it may be expressed as equal to the product of the time during which radiation takes place, the average difference of temperature between the radiating body and the air, and the radiation constant of the body.

I.

Comparison of thermometers.

When two or more thermometers are used in an experiment, their indications should always be compared, to determine whether they agree. Even the best thermometers are apt to differ in "zero point," so that they may give different readings for the same temperature, and yet measure temperature differences accurately. It is often necessary, particularly in problems involving the use of the method of mixtures, to measure various temperature differences with different thermometers, and to know them in terms of a single thermometer.

To compare thermometers, they should be placed in a vessel of water and readings made at frequent temperature intervals, over the whole range covered in the experiment. The water should be well stirred, and readings made on the thermometers compared as rapidly as may be consistent with accurate readings, the readings being estimated to tenths of the smallest graduated temperature intervals. If the temperature of the water is more than 20° different from room temperature, it is well to read the thermometers in direct and reverse order for each

temperature of comparison, the mean readings being compared, thus eliminating errors due to temperature changes. The numbers, or other distinguishing marks, of the thermometers used should in all cases be recorded.

An example of a comparison of three thermometers to be used in I_1 (the heat of vaporization) is given in the following table, the first reading being made in melting ice, and the others in water, hot water being added to that in which the thermometers are immersed for successive readings, the water being thoroughly stirred before readings, so that the whole may come to a uniform temperature.

COMPARISON OF THERMOMETERS.

| No 725 | | No 736. | | | No. 108. | |
|-----------|--------|-----------|--------|--------------|-----------|--------------|
| Readings. | Mean. | Readings. | Mean. | Differences. | Readings. | Differences. |
| - 0.12 | - 0.12 | -- 0.09 | - 0.09 | + 0.03 | - 0.2 | - 0.08 |
| + 4.36 | + 4.38 | + 4.38 | + 4.39 | + 0.01 | + 4.3 | - 0.08 |
| 4.40 | | 4.40 | | | | |
| 9.27 | 9.29 | 9.28 | 9.29 | 0.00 | 9.2 | - 0.09 |
| 9.30 | | 9.30 | | | | |
| 12.47 | 38.75 | 12.46 | 38.78 | - 0.01 | 12.4 | - 0.07 |
| 16.85 | | 16.83 | | - 0.02 | 16.8 | - 0.05 |
| 21.10 | 43.14 | 20.97 | 43.15 | - 0.03 | 21.1 | 0.00 |
| 25.73 | | 25.71 | | - 0.02 | 25.7 | - 0.03 |
| 30.06 | 43.14 | 30.05 | 43.15 | - 0.01 | 30.0 | - 0.06 |
| 34.23 | | 34.25 | | + 0.02 | 34.2 | - 0.03 |
| 38.76 | 43.14 | 38.79 | 43.15 | + 0.03 | 38.7 | - 0.05 |
| 38.73 | | 38.77 | | | | |
| 43.16 | 43.14 | 43.16 | 43.15 | + 0.01 | 43.1 | - 0.04 |
| 43.12 | | 43.14 | | | | |

Thermometer No. 725 taken as the standard of comparison.

From the data obtained, assuming thermometer No. 725 as the standard, compute and tabulate the temperature differences and plot a curve, using temperature variations as ordinates and temperatures of the respective thermometers as abscissas.

In making computations corrected thermometer readings should be used, the corrections being read directly from the curves.

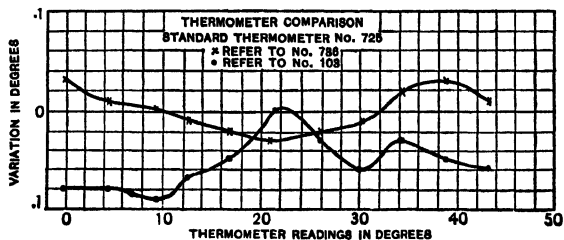

Fig. 43.

II.

Determination of the water equivalent of a calorimeter.

When a calorimeter containing water, etc., is heated or cooled, heat is absorbed or given out by the vessel itself in addition to that absorbed or liberated by its contents. The *water equivalent* of a calorimeter is a quantity of water which would absorb the same amount of heat, when warmed through a certain number of degrees, as is absorbed by the calorimeter when heated through the same range of temperature.

To determine the water equivalent, proceed as follows:

(1) Fill the calorimeter nearly two thirds full of water four or five degrees colder than the air, the weight of the water being known. This water should be kept thoroughly stirred, and its temperature should be observed by means of a thermometer hanging in it.

Add enough hot water, of known temperature, eight or ten degrees warmer than the air, to fill the calorimeter to within one or two centimeters of the top. Stir thoroughly, and record the reading of the thermometer in the mixture at intervals of fifteen seconds, until the temperature becomes practically constant. The hot water should be stirred immediately before it is poured in, and the temperature of both hot and cold water should be observed just the instant before mixing. It is best to choose

the temperature of the hot water so that the mixture will come to about the temperature of the air, corrections for radiation being unnecessary if this is done. The mass of the hot water used may be determined by weighing the mixture after the observations are completed. From the data obtained, the water equivalent is to be computed.* The student should make *at least three determinations*.

WATER EQUIVALENT OF CALORIMETER.

| | I. | II. | III. |
|------------------------------|-------|-------|-------|
| Mass of Calorimeter, No. 12, | 154.7 | 154.7 | 154.7 |
| Mass of Cal. + Cold Water, | 334.0 | 344.0 | 340.2 |
| Mass of Cold Water, | 179.3 | 189.3 | 185.5 |
| Mass of Cal. + Mixture, | 478.5 | 480.5 | 486.5 |
| Mass of Warm Water, | 144.5 | 136.5 | 146.3 |
| Tem. of Room, No. 108, | 24.0 | 21.0 | 21.0 |
| Tem. of Cold Water, No. 725, | 9.8 | 10.2 | 8.25 |
| Tem. of Warm Water, No. 736, | 35.6 | 36.6 | 37.4 |
| Tem. of Mixture, No. 725, | 20.88 | 20.85 | 20.4 |
| Water Equivalent, | 12.6 | 12.6 | 19.2 |

Water equivalent = 14.8.

If the material from which the calorimeter is made is known, the water equivalent may also be computed, as a check on the above results, from the mass and specific heat.

In the determination of the water equivalent, great care must be used in all temperature readings, or the results of successive determinations will be discordant. This is especially true in the case of small calorimeters. To obtain the best results, a number of separate determinations should be made, and

* The amount of heat that the calorimeter absorbs is very small compared with the amount absorbed by the water which it contains. For this reason slight errors of observation will generally cause a very great error in the computed result. A common source of error is the following: while the hot water is being poured into the cold water, it will lose some heat to the air. In the computations this small quantity of heat is necessarily treated as if it were absorbed by the calorimeter, thus giving too large a value to the water equivalent.

the average of all the results used. No single result should be discarded merely because it differs widely from the rest. A result can be legitimately discarded only when something has occurred during the experiment which tends to throw discredit on some of the observations, or when there is an obvious mistake in one of the readings.

In the most accurate calorimetric experiments it is necessary to determine not only the water equivalent of the calorimeter, but also the water equivalents of the thermometers, stirring rods, etc. In the experiments which follow, however, this is unnecessary.

In *all* calorimetric experiments, the *temperature of the room* should be recorded, as it will be found necessary in making corrections for radiation.

III.

Determination of the radiation constant of a calorimeter.

The loss of heat from a body which is a few degrees warmer than its surroundings is proportional: (1) to the time during which radiation takes place; (2) to the difference in temperature between the body and the room; (3) to a constant called the *constant of radiation*, depending upon the nature and extent of the radiating surface.

Note that this constant depends *only* on the surface, and not upon the nature of the interior of the body. The radiation constant of a calorimeter is, for example, the same when it contains mercury as when it is filled with water. But the rate of cooling will be different in the two cases on account of the difference in the two specific heats. Radiation is essentially a phenomenon which occurs at the surface of a body, and depends wholly upon the nature and temperature of this surface.

The gain of heat by absorption when the body is colder than its surroundings obeys the same laws. The law above stated is

known as Newton's law of cooling, and is really only an approximation to the truth. In the case of bodies differing in temperature from their surroundings by not more than 10° , the approximation is, however, good.

The radiation constant may be defined as the amount of heat which is lost by radiation in one minute when the radiating body is one degree hotter than the air. For a difference in temperature of θ° , the radiation is θ times as great; and for t minutes instead of one minute the loss is t times as great. It will thus be seen that if the radiation constant is known, the loss of heat from a body such as a calorimeter can be readily computed.

In most calorimetric work, corrections must be made for the loss of heat by radiation, or the gain by absorption, during the time of the experiment. The first step in any calorimetric experiment should therefore be the determination of the radiation constant. The method is as follows:

(1) Fill the calorimeter to within 1 or 2 cm. of the top with water considerably warmer than the air (say, 10° – 20° warmer). The mass of the water should be known. Suspend a thermometer in the center of the calorimeter, and observe the temperature at intervals of one minute as the water cools. These observations should be continued for at least an hour, the water being thoroughly stirred before each reading. The temperature of the room, as indicated by a thermometer hanging near, should also be occasionally recorded.

(2) With the data obtained plot two curves, using times as abscissas in each case, and temperatures of air and water as ordinates. A smooth curve should now be drawn in each case, passing as nearly as possible through all the points plotted. Any slight deviations from such smooth curves are probably due to accidental errors in the observations. The curve for the temperature of the radiating surface will be convex toward the x -axis, since the rate of loss of heat decreases as the surface temperature approaches air temperature.

From the data given by these curves, and knowing the mass of water, the statements made above may be verified, and the radiation constant computed. Since the slope of the curve of surface temperature at any point gives the rate of drop of temperature, and the ordinate between the two curves at the point gives the difference of temperature between the radiating surface and the air, the mass of water plus the water equivalent of the calorimeter multiplied by the slope of the curve at the point chosen, and divided by the ordinate intercepted between the two curves at this point, will give a value of the radiation constant. Note that the slope of the curve and the length of the ordinate must be in terms of the scales used in plotting the curves. Find three values of the radiation constant from the curves plotted.

It should be observed that an approximation must here be made, viz., that the temperature of the surface of the calorimeter is the same as that of the liquid contained in it. If the liquid is kept thoroughly stirred, and if the material from which the calorimeter is made is a good conductor, no great error is, however, introduced.

For example, let the mass of water *plus* the water equivalent of the calorimeter be 352.6 grams. Suppose that the temperature fell from $30.^{\circ}8$ to $29.^{\circ}70$ in five minutes, the average temperature of the room being $11.^{\circ}25$. The temperature of the water having changed $1.^{\circ}1$, the loss of heat is equal to 1.1×352.6 or 387.9 calories. Since this loss took place in five minutes, the loss in one minute was $387.9 \div 5$, or 77.6 calories. The average difference in temperature between water and air was 19° . The loss for one minute, and for 1° difference in temperature, would therefore be $77.6 \div 19 = 4.08$ + minor calories, which is the radiation constant. Similar computations made with different portions of the data should give nearly the same result. Make eight or ten such computations and use the mean.

In using the constant thus obtained to correct for radiation losses, it usually happens that the temperature of the calorimeter

RADIATION CONSTANT.

| Time. | Tem. of Vessel. | Tem. of Room. | Radiation Constant. | Time. | Tem. of Vessel. | Tem. of Room. | Radiation Constant. |
|-------|-----------------|---------------|---------------------|-------|-----------------|---------------|---------------------|
| 3-34 | 30.8 | 11.2 | | 3-47 | 28.0 | 11.1 | |
| 35 | 30.56 | | | 48 | 27.8 | | |
| 36 | 30.36 | | | 49 | 27.6 | | 4.16 |
| 37 | 30.12 | | | 50 | 27.4 | | |
| 38 | 29.90 | 11.3 | | 51 | 27.23 | | |
| 39 | 29.70 | | 4.08 | 52 | 27.03 | | |
| 40 | 29.46 | | | 53 | 26.88 | 11.0 | |
| 41 | 29.28 | | | 54 | 26.70 | | 3.93 |
| 42 | 29.03 | | | 55 | 26.50 | | |
| 43 | 28.83 | 11.2 | | 56 | 26.33 | | |
| 44 | 28.60 | | 4.33 | 57 | 26.15 | | |
| 45 | 28.40 | | | 58 | 25.95 | 10.8 | |
| 46 | 28.20 | | | 59 | 25.80 | | 4.14 |

Mass of Calorimeter + Water = 492.5 grams.

Mass of Calorimeter = $\frac{154.7}{337.8}$

Water Equivalent = $\frac{14.8}{352.6}$ grams.

Radiation Constant = 4.13 calories.

does not remain constant throughout the experiment, so that the rate at which heat is lost by radiation is continually changing. The method to be used in such cases is illustrated by the following example:

The temperature of a mixture of ice and water in a calorimeter is observed at intervals of one minute and is found to vary as follows: 29°, 26.°5, 24°, 22.°6, 21.°4, 20.°8, 20.°6, 20.°5, the temperature of the air being 22°. The average temperature of the calorimeter during the seven minutes is therefore 23.°18 (found by adding all the readings and dividing by 8). Radiation has taken place for seven minutes at a rate whose average value is that corresponding to a difference to temperature of 1.°18 from the air. If the radiation constant is 4.13, the loss of heat is $4.13 \times 1.18 \times 7 = 34.2$ calories.

EXPERIMENT I₁. Determination of the heat of vaporization of water.

The apparatus for this experiment may be arranged in a great variety of ways. The essential parts are :

- (1) Some vessel in which steam may be generated.
- (2) A calorimeter, which may be any metallic vessel of suitable size.

(3) Tubes of metal or glass by which the steam may be conveyed to the calorimeter. The latter should be sheltered from

the heat radiated from the boiler, and some device should be supplied to prevent the water which condenses in the tubes from entering the calorimeter. Figure 44 shows a convenient form of apparatus for this determination.

The thermometers to be used should be compared and the water equivalent and radiation constant of the calorimeter should first be determined, as previously described. Observations may

then be made as follows to determine the heat of vaporization.

(1) Fill the calorimeter to within 2 or 3 cm. of the top with a known mass of water considerably colder than the air (from 8° to 12° colder).

(2) Pass steam into the calorimeter from a vessel of boiling water by means of the tubes provided for the purpose, keeping

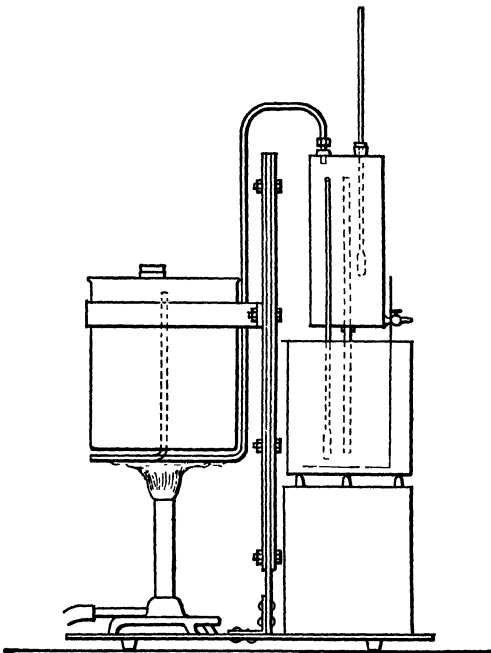

Fig. 44.

the water in the calorimeter thoroughly stirred, and observe its rise in temperature at intervals of one minute, until it has been heated as far above the temperature of the room as it was previously below it. Cut off the steam supply, continue to stir the water in the calorimeter, and read the thermometer every 15 seconds until it reaches its maximum temperature and begins to drop, thus insuring the getting of the highest mixture temperature. If the steam is superheated, its temperature should also be determined at minute intervals. The barometer should be read and tables or curves consulted to find the true boiling point of water at atmospheric pressure, which is approximately the pressure at which the steam is condensed, so that a correction can be made for the heat given up by the superheated steam.

(3) Determine the mass of steam condensed by weighing the calorimeter and contents at the end of the experiment, the weight of the vessel and of the cold water having been previously determined. These weighings should be made with considerable care, as the mass of the condensed steam may be quite small. To make sure that the steam is dry, it should be slightly superheated by a flame placed under the tube which leads to the calorimeter. The temperature of the steam just before entering the water may be observed by means of a thermometer inserted in the tube. The steam should be allowed to pass through the tubes for a considerable time before beginning the experiment, in order to make sure that they are thoroughly warmed (to avoid condensation).

(4) From the data obtained compute the heat of vaporization of water, or the heat of condensation of steam. Corrections should be made for the loss or gain of heat due to radiation and absorption, and for the heat capacity of the calorimeter itself.

This correction, due to radiation, may be reduced to a minimum by allowing the flow of steam to continue until the water in the calorimeter reaches a temperature as much above that of the air as it was initially below that temperature. But the

correction should always be computed. At least three determinations should be made.

HEAT OF VAPORIZATION OF WATER.

| | I. | II. | III. |
|----------------------------|------------------|-------|-------|
| Mass of Calorimeter, | 154.7 | 154.7 | 154.7 |
| Mass of Cal. + Cold Water, | 438.0 | 427.7 | 434.0 |
| Mass of Cold Water, | 283.3 | 273.0 | 279.3 |
| Mass of Cal. + Mixture, | 450.0 | 440.6 | 447.2 |
| Mass of Condensed Steam, | 12.0 | 12.9 | 13.2 |
| Temperature of Room, | 21.0 | 21.0 | 21.0 |
| Temperature of Cold Water, | 10.4 | 8.27 | 10.82 |
| No. 725 | | | |
| Temperature of Steam, | TIME. 105° | 105° | 103° |
| | 1½ m. 107 | 105 | 104° |
| | No. 108 3 108 | | 105° |
| | 4 107 | | |
| Temperature of Mixture, | 0 13.4 | 14.0 | 12.8 |
| | 5 16.2 | 19.6 | 13.6 |
| | 1.0 18.0 | 27.2 | 17.8 |
| | No. 725 1.5 20.7 | 34.4 | 22.0 |
| | 2.0 23.7 | 35.0 | 24.7 |
| | 2.5 26.5 | 35.45 | 28.5 |
| | 3.0 31.0 | | 32.9 |
| | 3.5 34.4 | | 37.0 |
| 4.0 34.9 | | 37.7 | |
| Heat of Vaporization, | 545 | 544 | 540 |

EXPERIMENT I₂. Determination of the heat of fusion of ice.

The radiation constant and the water equivalent of the calorimeter used are first to be determined and the thermometers compared, as previously described. Observations may then be taken to determine the heat of fusion as follows:

(1) Fill the calorimeter to within 2 or 3 cm. of the top with a known mass of water, 3° or 4° warmer than the air.

(2) Stir thoroughly and observe the temperature. Then drop in a piece of ice; hold it under water by means of a stirrer arranged for the purpose, and observe the temperature of the

water at intervals of half a minute until the ice is melted, and a fairly constant temperature is reached. In case the melting of the ice cools the calorimeter below the temperature of the room, it is well to continue observations of temperature, stirring thoroughly before each reading, until the calorimeter begins to warm again by absorption of heat from the air.

The ice used should be at its melting point. This is assured by keeping it, for some time inside the warm room. It should be carefully dried by means of filter paper just before dropping it into the calorimeter.

The mass of ice used may be obtained by weighing the calorimeter and contents after the observations are completed, the weight of the vessel and of the warm water being already known.

From the data obtained compute the heat of fusion.

Corrections are to be made for the loss of heat by radiation, and for the water equivalent of the calorimeter. Make at least three complete determinations.

EXPERIMENT I₃ I. Determination of the specific heat of a solid.

(1) Place the metal whose specific heat is to be determined in the calorimeter, and support it in such a way that it does not touch the sides or bottom. Enough water of known weight should now be placed in the calorimeter to just cover the metal, the temperature of the water being from 8° to 15° above that of the air.

(2) Allow the calorimeter and contents to stand for at least ten minutes in order to make sure that the metal has acquired the temperature of the water. Then add cool water, stir thoroughly, and observe the temperature at half-minute intervals until it reaches a practically constant value. The temperature and amount of the cold water should be such as to bring the final temperatures of the mixture very close to that of the air. A few preliminary trials will show about what the temperature

should be. The temperature of hot and cold water, each thoroughly stirred, should be observed immediately before mixing. The weight of the cold water added is to be found by weighing the calorimeter and contents after the other observations are completed.

As the specific heat of any metal is much less than that of water, it will be advisable to take a rather large mass of the metal. For good results, its heat capacity should be comparable with that of the mass of water used. If the metal is not a good conductor of heat, it should be in small pieces.

The method here described is merely one of many which may be used in the determination of specific heat.

The student will find it instructive, if time is available, to check his results by one of the numerous other methods which will be found described in various textbooks.

The water equivalent and the radiation constant of the calorimeter used are to be determined, and the thermometers used are to be compared as described in the general directions at the beginning of this group.

The weight of the metal being known, its specific heat may now be computed. Corrections are to be made for radiation and for the absorption of heat by the calorimeter itself. At least three determinations should be made.

EXPERIMENT I₃ II. Specific heat of a liquid by the method of cooling.

From Newton's law of cooling given in the introduction to this group it follows that the radiation constant of a vessel does not depend on the contents of a vessel, but only on the nature and extent of the surface. The radiation constant R is defined as the amount of heat lost per minute per degree of difference of temperature between the radiating surface and the surrounding medium. From this it follows that

$$R = \frac{c(\theta_1 - \theta_2)}{\Delta t}, \quad (156)$$

in which c is the heat capacity of the vessel, θ_1 and θ_2 the temperatures of the radiating surface at the beginning and end of the time interval t , and Δ the average difference in temperature between the radiating surface and the air during the time t .

(In general Δ will not be $\frac{\theta_1 + \theta_2}{2} - \theta_{\text{air}}$. Why?)

The temperature of the surface may be taken as that of the liquid within the calorimeter if the liquid is well stirred and the calorimeter has thin walls and is a good conductor.

The heat capacity of the system is the amount of heat lost per degree of drop in temperature and is therefore equal to the water equivalent of the vessel and contents, or $m_1s_1 + m_2s_2$, in which m_1 and m_2 are the masses of the calorimeter and contents, respectively, and s_1 and s_2 their specific heats.

Then equation 156 may be written

$$R = \frac{(m_1s_1 + m_2s_2)(\theta_1 - \theta_2)}{\Delta t}. \quad (157)$$

Some other liquid of specific heat s_3 would, of course, give the same radiation constant. This fact makes it possible to determine the specific heat of a liquid by the method of cooling, for we may write

$$R = \frac{(m_1s_1 + m_2s_2)(\theta_1 - \theta_2)}{\Delta_1 t_1} = \frac{(m_1s_1 + m_3s_3)(\theta_1' - \theta_2')}{\Delta_1' t_1'}. \quad (158)$$

The water equivalent of the calorimeter is given by m_1s_1 , or may be determined by experiment. The quantity m_2 is the mass of water used in determining the value of R , and s_2 , the specific heat of water which may be taken as unity. The mass of the liquid whose specific heat s_3 it is desired to find is m_3 .

It is necessary to perform the same preliminary experiments to compare thermometers and find the water equivalent of the calorimeter as in the other experiments in the group, following the instructions given in the introduction to the group.

A run of an hour is to be made to determine the value of R

for the calorimeter, using water in the calorimeter. Then a second run of an hour is to be made, using the liquid whose specific heat is to be determined in the calorimeter in place of the water.

The initial temperature in each of these determinations should be about 15 degrees above room temperature. Readings of the temperature of the liquids are to be taken every minute, the liquids being well stirred in order that the temperature of the surface of the calorimeter be as nearly that of the contained liquid as possible. In each case the room temperature should be read every five minutes.

Twelve determinations of R are to be made from the first set, taking 5-minute intervals. The mean value of R thus determined is to be taken from which to compute the specific heat of the liquid. Make six sets of computations for the determination of the specific heat of the liquid investigated, using 10-minute intervals of the run made with it in the calorimeter.

Plot two radiation curves. In each case use calorimeter temperatures and room temperatures as ordinates and time as abscissas. From the curve drawn for the water content, find two values of R from the slope and then apply the mean of these values to the second curve to find two values of the specific heat. See equation 159, p. 150.

EXPERIMENT I₄. Radiating and absorbing powers of different surfaces.

The objects of this experiment are to investigate the radiation and absorption of heat from different surfaces, and to determine the relation between the radiating and absorbing powers of the same surface.

The radiating constant of a surface may be defined as the number of calories that will be radiated from one square centimeter of the surface in one minute, for a difference in temperature of one degree between the surface and its surroundings. In like manner the constant for absorption may be defined as

the number of calories that will be absorbed by one square centimeter of the surface under similar conditions.

The radiation constant of a surface may be determined by dividing the heat lost by a vessel in a given time, by the time, the average difference in temperature between the surface and the air, and the area of the vessel. The absorption constant may be computed in a similar manner from the heat gained in a given time.

It is to be observed that radiation and absorption depend upon the temperature of the radiating or absorbing surface, and not upon the temperature of the contents of the vessel. If the walls of the vessel are thin, however, and of some highly conducting material, no great error is introduced by assuming that the contents of the vessel are at the same temperature as the surface.

The method of the experiment is as follows:

(1) Fill the vessel for whose surface the radiation constant is to be determined with water 15 or 20 degrees warmer than the air, and place it upon a poorly conducting support, such that the vessel will be free to radiate its heat in all directions.

(2) Observe the temperature by means of a thermometer hanging in the center of the vessel, at intervals of two minutes, stirring the water thoroughly before each reading. The temperature of the air should also be observed at intervals of about five minutes, and for good results must remain nearly constant throughout the experiment. Continue these observations for at least half an hour.

A curve should now be plotted with times as abscissas and temperatures as ordinates. From this curve, or from the data themselves, make four or five independent computations of the radiation constant. If the constant is computed from the curve, it will be necessary to find the "pitch," $d\theta + dt$ (θ = temperature; t = time), at different points on the curve, by drawing tangents.

From Newton's law of cooling, the radiation constant R is given by the equation

$$R = \frac{c}{A} \cdot \frac{1}{\theta - \theta_a} \cdot \frac{d\theta}{dt}, \quad (159)$$

where c is the heat capacity of the vessel, A its superficial area, and θ_a the temperature of the air. The value of c is determined by adding the water equivalent of the vessel to the weight of the water contained in it.

The following method of computing the results will be found instructive as an example of the employment of graphical methods, and may be used instead of the above if desired.

$$\frac{d\theta}{dt} = \frac{RA}{c} \cdot (\theta - \theta_a). \quad (160)$$

$$\therefore \frac{d\theta}{\theta - \theta_a} = \frac{RA}{c} \cdot dt. \quad (161)$$

$$\text{By integration: } \log(\theta - \theta_a) = \frac{RA}{c} t + K, \quad (162)$$

where K is the constant of integration.

If, therefore, a curve is plotted whose co-ordinates are t and $\log(\theta - \theta_a)$, respectively, the result should be a straight line. In the equation of this line, $\frac{RA}{c}$ enters as one of the constants.

Note that the logarithm which occurs in the above equation is the Napierian logarithm. Ordinary logarithms may, however, be used until the final result is reached.

The constant for absorption can be determined in a similar manner by filling the vessel with water 15 or 20 degrees colder than the air, and observing the gradual rise in temperature due to absorption.

These observations should be repeated with three or four vessels which are of the same size and shape, but differ widely in the character of the radiating surface. Polished metal and lampblack surfaces will probably be found to differ most widely in their radiating powers. No difficulty should be experienced

in carrying on the observations with four vessels at the same time.

It is to be observed that a slight error is introduced in this experiment by assuming that all the heat is lost by radiation, for part of the loss is really due to convection. For small differences of temperature, however, the loss by convection is small, and may be treated as though it obeyed Newton's law. The radiation constants obtained represent, therefore, the sum of the losses due to the two causes.

(In connection with this experiment, see the general directions for calorimetric work.)

EXPERIMENT I₅. Mechanical equivalent of heat. Joule's law. Electrical method.

When an electric current flows through a wire, heat is developed. Joule's law affirms that the amount of heat developed varies with the square of the current, with the resistance of the wire, and with the time, in accordance with the following expression,

$$\text{Heat developed} = RI^2t = \rho dIt. \quad (163)$$

The heat is expressed in work units. If R , I , ρd , and t be expressed in *C. G. S.* units, the heat will be expressed in ergs, or if they be expressed in the practical units, the ohm, the ampere, and the volt, t being expressed in seconds in either case, the heat will be given in joules.

The first law of thermodynamics states that "whenever mechanical energy is converted into heat, or heat into mechanical energy, the ratio of the mechanical energy to the heat is constant." That is,

$$W = JH, \quad (164)$$

where H is the amount of heat developed, W the work done, and J the reduction factor, called the mechanical equivalent of heat.

Since the electrical energy used up in a circuit or a part of a circuit may be expressed in terms of mechanical units, it is possible to determine the value of J electrically.

The electrical circuit is to be made up as follows: A storage battery is to be used as a source of E. M. F. In series with the storage battery B , Fig. 45, connect a variable resistance R , capable of carrying two or three amperes, an ammeter A , and the electric calorimeter C . Shunt a voltmeter V around the calorimeter terminals. A single electrical measuring instrument, a millivoltmeter, may be used to measure both the current and voltage if connected as in Fig. 45 b . When the double pole, double throw, switch K is closed so as to connect the instrument to the proper terminals of a suitable shunt S , put

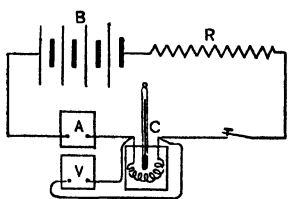
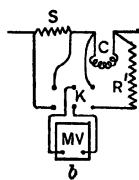

Fig. 45.



in the main circuit in place of the ammeter, it will give the current in amperes. When the switch is closed in the opposite way, the instrument is connected to the

terminals of the heating coil, and with a suitable resistance R' in series it will read in volts.

Fill the calorimeter about two thirds full of distilled water at a temperature of 10° C. or 12° C. below room temperature, the mass of water being known.

Place the calorimeter in its support, lower the cover carrying the resistance coil into position, suspend a thermometer so that the bulb will be covered with water, and start the current flowing. Adjust the resistance in the circuit to give about two amperes of current.

Begin making observations of the temperature of the water about a minute after the current has been adjusted, and every minute thereafter until the water has attained a temperature about as much above room temperature as it was originally below, then break the circuit. Make reading of the room temperature every two minutes and read the current and voltage carefully every minute throughout the run.

Caution. Be careful to stir the water thoroughly before each temperature reading, but do not stir it so violently that water will spill out of the calorimeter.

Consider the first run merely as a preliminary one to get acquainted with the method of operation. No computations of J are to be based on this run, unless upon inspection by an instructor the data is considered sufficiently accurate to be worked up.

After breaking the circuit continue to read the temperature of the water and the room temperature at intervals of one and five minutes, respectively, for ten minutes in order to determine the radiation constant of the calorimeter. One set of observations for the radiation constant will be sufficient.

Make two runs for the determination of J in the manner above described, but with different current values. Use currents of about 1.8 and 2.0 amperes. Read the current and voltage as nearly simultaneously as possible every minute. Be sure to know the mass of water for each run.

Plot two curves on the same sheet to the same scale for each run, using time as abscissas in both, water temperature as ordinates in one and room temperatures as ordinates in the other. The computations to be made are to be based on the curves drawn. Two values of J are to be computed from each set of data, by choosing two pairs of points such that one of the points is just as much above room temperature as the other is below. Good judgment should be used in selecting the points to be used. Points too near the beginning of the curves may belong to such a period of the run that steady conditions had not yet been reached.

The water equivalent of the apparatus may be determined by using masses and specific heats of those parts of the apparatus which are subjected to change of temperature. Glass parts are to be considered as nonconducting. If a Dewar tube be used as a calorimeter, its mass should be determined and a careful estimate made as to the part in contact with the water. The

water equivalent of the immersed parts of the thermometer and coil support should be determined, since in this experiment the mass of water used may not be great in comparison to the water equivalent of these parts. If a metal calorimeter be used, its whole mass is to be used in determining the water equivalent.

From the amount of heat developed in calories and the work done by the current, as expressed in equations 163 and 164, the four values of J are to be computed.

GROUP J: EXPANSION.

(J₁) *Linear expansion*; (J₂) *Volume expansion*.

EXPERIMENT J₁. Coefficient of linear expansion.

In general when materials are subjected to changes in temperature there will be changes in dimensions. If the body is isotropic, that is, if it has similar properties no matter the direction taken within the body, the change in length per unit of length will be the same. In crystals the change of length per unit of length may vary with the direction taken. In general the change in length per unit of length per degree change of temperature is called the coefficient of expansion. The general expression for the length of a body is represented by the following equation:

$$l = l_0(1 + \alpha t + \beta t^2 + \dots). \quad (165)$$

It is usually sufficient, where the changes of temperature are not great, to use only the first two terms within the brackets and write

$$l = l_0(1 + \alpha t), \quad (166)$$

in which l is the length at the final temperature, l_0 the length at the initial temperature, t the temperature difference, and α the coefficient of expansion. The coefficient α is often determined between the temperatures of melting ice and boiling water under standard conditions of atmospheric pressure. If the coefficient obtained between intermediate temperatures is to be referred to the temperature of melting ice, as is the case in the

following experiment, the length at both temperatures must be referred to the melting ice temperature.

The experiment is to determine the average coefficient of expansion between two temperatures, one of which is the boiling point of water, and also to find the average coefficient when referred to the melting point of ice.

Focus a micrometer microscope on a scratch on the free end of one of the tubes supplied, so fixing the microscope that it may be moved in a direction parallel with the axis of the tube, and the amount of motion be accurately measured.

Insert a thermometer within the free end of the tube and take its reading after sufficient time has elapsed for it to have attained the temperature of the tube. Make readings on the thermometer and the micrometer. Pass steam through the tube until the thermometer within the tube reaches a steady value, then take its reading, and also the new micrometer reading, having followed the scratch on the tube. Measure the distance from the scratch to the block at the fixed end of tube. Cool the tube by passing cold water through it from the tap.

Make three sets of readings as outlined above on each tube. From the data obtained compute the values of the coefficients for each tube as indicated above.

Does the coefficient of linear expansion depend on the material studied, the unit of length used, and the scale of temperature? For each tube supplied show the effect of changing the unit of length used, and the temperature scale.

Why is it necessary to measure the elongation so carefully while the total length is measured with a meter scale estimating only to tenths of millimeters?

EXPERIMENT J₂. Cubical expansion of solids and liquids.

The coefficient of volume expansion of a solid or liquid is defined as the change in volume per unit volume per degree change of temperature.

$$V = V_0(1 + \beta t). \quad (167)$$

It is easily shown for isotropic bodies, in which the linear coefficients of expansion along the three principal axes are the same, that $\beta = 3\alpha$, neglecting terms of the second and third order of magnitude. In the case of liquids the volume coefficient alone has a physical meaning.

This experiment may be used to find the value of β for either solids or liquids. In the case of finding the value of β for a glass bottle the value of the absolute volume coefficient of mercury as determined by Regnault's method,* which is independent of the expansion of the containing vessel, is used.

The bottle should be clean and thoroughly dried. It is then weighed, and pure mercury is poured into it by means of a small funnel. Small bubbles of air on the glass can be removed by tilting the bottle when not quite full. Mercury is added or withdrawn, as the case may require, so that the level of the mercury surface coincides with a scratch on the bottle's neck. The temperature of the mercury having been obtained, the bottle and its contents are weighed on a nonsensitive balance.

The bottle containing the mercury is then placed in a beaker filled with sufficient water to bring its level above the mark on the neck of the bottle. The whole is to be heated on a sand bath up to about 90° C. When this temperature, observed by means of a thermometer dipping in the water, has been maintained *constant for ten or fifteen minutes*, mercury is carefully drawn out of the neck of the bottle by means of a small pipette, until the surface of the remainder coincides with the scratch. The mass of the mercury withdrawn is to be carefully determined, a chemical balance being used for this purpose.

Make two complete determinations of the desired coefficient.

Let W be the mass of mercury filling the bottle up to the index at the original temperature,

ω be the mass of the mercury removed at the final temperature,

* Edser's Heat for Advanced Students; pp. 76-80.

ρ and ρ' the densities of the mercury at the initial and final temperature respectively,

V and V' be the volumes of the bottle at the initial and final temperatures respectively,

t the temperature difference, and

β , βg , and g be the absolute coefficient of expansion of mercury, the apparent coefficient of expansion of mercury in glass, and the coefficient of volume expansion of glass, respectively.

The initial volume of the bottle filled with mercury is

$$\frac{W}{\rho} = V, \quad (168)$$

and the final volume is

$$\frac{W - \omega}{\rho'} = V'. \quad (169)$$

$$V' = V(1 + gt), \quad (170)$$

or

$$g = \frac{V' - V}{Vt}. \quad (171)$$

Substituting in equation 171 the values of V and V' from 168 and 169,

$$g = \frac{\frac{W - \omega}{\rho'} - \frac{W}{\rho}}{\frac{W}{\rho}t}. \quad (172)$$

Since

$$\rho' = \rho(1 - \beta t), \quad (173)$$

$$g = \frac{W - \omega - W(1 - \beta t)}{Wt}. \quad (174)$$

From which

$$g = \beta - \frac{\omega}{Wt}. \quad (175)$$

The quantity $\frac{\omega}{Wt}$ is approximately equal to the apparent coefficient of mercury with respect to glass, so that

$$g = \beta - \beta g. \quad (176)$$

From the above equation it may be stated that the absolute coefficient of mercury is equal to the coefficient of expansion of the glass plus the apparent coefficient of mercury in glass.

CHAPTER IV.

GROUP L: LENSES AND MIRRORS.

(L_1) Radius of curvature of a lens (by reflection); (L_2) Focal length of a concave mirror; (L_3) Focal length of a convex lens; (L_4) Focal length of a concave lens; (L_5) Magnifying power of a telescope; (L_6) Magnifying power of a microscope and focal lengths of same.

EXPERIMENT L_1 . Determination of the radius of curvature of a lens by reflection.

The apparatus consists of a telescope placed midway between two small gas jets (g, g' , Fig. 46), the distance between the

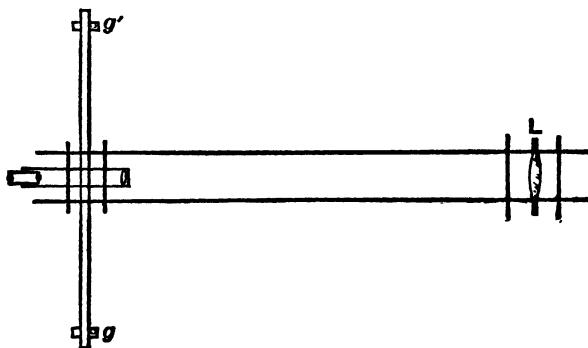

Fig. 46.

jets being capable of adjustment. The lens (L , Figs. 46 and 47) whose curvature is desired is placed at a distance of from 1 to 2 m., and in such a position that the reflected images of the two flames can be seen in the telescope. The apparent distance between the images is measured by means of a scale (Fig. 48) fastened to the surface of the lens, and from this

measurement, together with the distance from the lens to the flames, and the actual distance between the flames, the radius of curvature can be computed.

The problem with which this experiment deals consists in finding the radius of curvature r ($= co$, Fig. 49) in terms of L ,



Fig. 47.

the distance between the gas jets (gg'); of D , the distance from telescope to lens (cT), and of s , the apparent distance of the

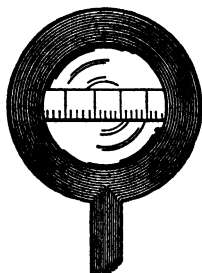

Fig. 48.

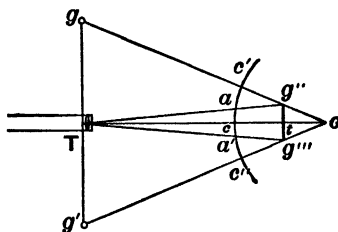

Fig. 49.

images (g'' , g''') as measured upon the scale on the face of the lens (aa').

From the relation of conjugate foci we have

$$\frac{1}{gc'} - \frac{1}{g''c'} = -\frac{2}{oc'}, \tag{177}$$

and in case the telescope is at a distance from the lens much greater than L , we may write as an approximation

$$\frac{1}{Tc} = \frac{1}{tc} - \frac{2}{oc'}, \tag{178}$$

or

$$d = \frac{Dr}{2D + r}, \tag{179}$$

where

$$d = ct.$$

From the geometry of similar triangles we have, also,

$$l = s \frac{(D + d)}{D}, \quad (180)$$

$$l = \frac{L(r - d)}{r + D}, \quad (181)$$

where $l = g''g'''$, which is the distance between the images.

The quantities l and d are to be eliminated, and r is to be expressed as stated above.

Combining equations 180 and 181, we have

$$\frac{s(r + D)}{D} = \frac{L(r - d)}{(D + d)} = \frac{Lr}{2D}, \quad (182)$$

or
$$r = \frac{2sD}{L - 2s}. \quad (183)$$

To obtain accurate results, the conditions of the experiment should be varied by changing the position of the lens, and by altering the distance between the flames. Make readings for three positions of the flame for each of four positions of the lens.

It may happen that two pairs of images are seen by reflection. This is due to the fact that a part of the light from the flames passes through the first surface and suffers reflection at the second. One pair of images will probably be erect and the other inverted, so that no difficulty need be experienced in distinguishing between the two.

Addendum to the report:

Rays from the gas jet g are reflected from the face of the lens, and enter the telescope T . The angles which the incident and reflected rays make with the normal to the surface are equal. From this consideration deduce formula 183 without using the relation of conjugate focal lengths, or the position of the image g'' .

EXPERIMENT L₂. Focal length of a concave mirror.

The object of this experiment is to verify the formula which shows the relation between the conjugate foci and the principal focus of a concave mirror; viz.

$$\frac{1}{p_1} + \frac{1}{p_2} = \frac{2}{r} = \frac{1}{f} \quad (184)$$

The apparatus required consists simply of the mirror *m*, a metal screen *S* with holes in it to be used as a source or "object," a screen *S'*, and a gas flame.

The mirror should first be mounted (see Fig. 50) in such a way that its principal axis is nearly horizontal. The metal screen may then be placed at some point in this axis, with the gas flame a short distance behind it. It will be found more convenient to work in a room which is partially darkened.

The position of the image may now be found by trial, a screen *S'* (preferably of ground glass) being placed in such a position that the image thrown upon it is as sharp as possible. This adjustment may be made more accurately if the mirror is partly covered,

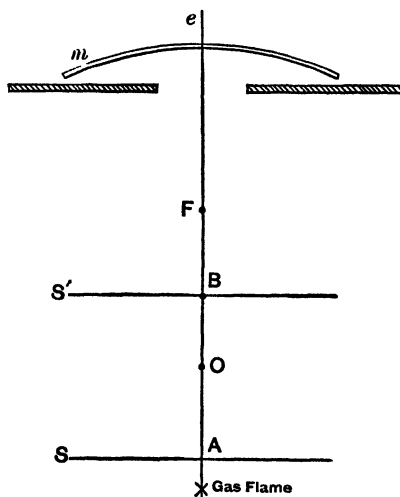

Fig 50.

so that only a comparatively small portion near the center is used. The distances of object and image from the mirror are now to be measured, together with a dimension of the object and the size of the corresponding part of the image. Repeat these measurements for three or four different positions of the scale, the position in each case being such that the image lies between the scale and the lens. Make four settings of the

object, giving images farther from the mirror than the object. These settings can be easily made if the object be placed just to one side of the axis of the mirror and the ground-glass screen just to the other, and shading the screen from the source of light. The focal length and the radius of curvature are to be computed from each of the observations.

As a check upon the results, the center of curvature may be located by placing a needle, or other pointed object, in such a position that the image of its point shall coincide in position with the point itself. This may be done quite accurately by moving the eye about and noting whether the relative positions of image and object vary. Make five independent settings. Find the radius of curvature by means of a spherometer. (See Exp. A₁.)

Addenda to the report :

(1) From the data obtained, verify the formula which shows the relation between the size of the image and its distance from the mirror; *i.e.* if the lengths of object and image are, respectively, l_1 and l_2 ,

$$\frac{l_1}{l_2} = \frac{p_1}{p_2}.$$

(2) Give a demonstration of the formula above referred to; also the formula for conjugate foci.

(3) Indicate the advantage of using only a small central portion of the surface of the mirror.

EXPERIMENT L₃. Determination of the focal length of a convex lens.

The focal length of the lens used is to be determined by each of the four methods described below, six observations being made in each case, three with one face of the lens toward the object and the other three with the lens reversed. In methods 3 and 4 the distance from the object to the lens is to be changed for each set of readings. Find the average value of the focal length for each method.

(1) The lens is made to form an image F , of some object whose distance is so great that light proceeds from it to the lens in rays that are very nearly parallel. A screen of ground glass or paper is adjusted until the image thrown upon it is as distinct and sharp as can be obtained. The focal length is then equal to the distance from the screen to the center of the lens. This method is not capable of great accuracy, but is more direct than those which follow.

(2) A telescope which has been focused for parallel rays is used to observe some sharply defined object as seen through the lens. The position of the lens having been adjusted until the object is seen to be properly focused in the telescope, the distance between lens and object is equal to the focal length re-

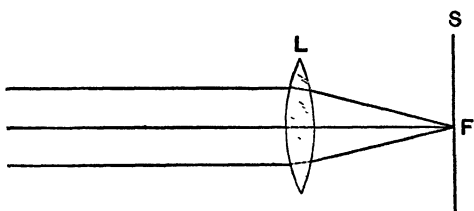

Fig. 51.

quired. In principle this method is practically the same as that first described, and the degree of accuracy that can be attained is about the same in each.

(3) An object is placed at any convenient distance in front of the lens, and a screen is adjusted until the image received upon it is sharply defined. The focal length can then be computed from measurements of the distances of object and image from the lens. If p_1 and p_2 are these two distances, we have

$$\frac{1}{p_1} + \frac{1}{p_2} = \frac{1}{f}. \quad (185)$$

The luminous object used may be the flame of a candle or gas jet. There are some objections, however, to the use of a flame, on account of the flickering caused by air currents. Better results can usually be obtained by using a fine thread or wire which is stretched across an opening in an opaque screen (Fig. 52). When the aperture is illuminated by means of a

lamp, the shadow of the wire forms an image which is unaffected by the flickering of the flame, and which can be very sharply focused.

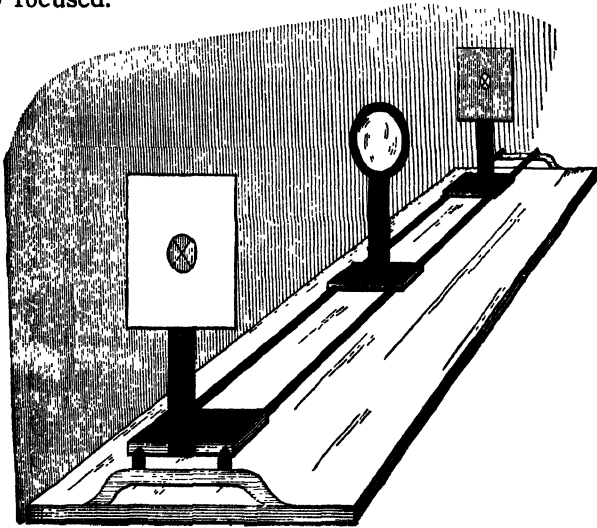

Fig. 52.

For four of the settings make measurements of some dimension of the aperture and the corresponding dimensions of the images, and test the relation

$$\frac{p_1}{p_2} = \frac{d_1}{d_2}, \quad (186)$$

in which d_1 and d_2 refer to the dimensions measured.

(4) Placing the object at any convenient distance from the lens, adjust the position of the screen until the image is sharply focused. Then, without changing the position of the screen, move the lens until a second position is found, such that a sharp image is formed. From the distance between object and screen, and the distance through which the lens is moved, the focal length can be computed. If l and a are the two distances,

$$f = \frac{l^2 - a^2}{4l}. \quad (187)$$

This method of determining focal length has the advantage of being uninfluenced by any uncertainty as to the thickness of

the lens and the position of the principal points. Since it is merely the distance through which the lens is moved that is required, measurements can be made to any convenient point on the support of the lens, and no correction need be made for the thickness of the glass. For this reason the method will probably give better results than can be obtained by any of the three methods first described.

Addenda to the report:

(1) Sharper images, and therefore more accurate results, will be obtained if the lens is covered, so that only a small region near the center is used. (Explain.)

(2) From the curvature of each face of the lens and your determination of the focal length, by method 4, compute the index of refraction of the glass from which it is made. The radius of curvature of each face is to be determined by means of a spherometer. (See Exp. A₁.)

EXPERIMENT L₄. Focal length of a concave lens.

Since a concave lens is a diverging one, its focal length cannot be measured directly. The auxiliary lens method is to be used in this experiment. A concave lens put in the path of the convergent light from a convex lens may cause it to become divergent, parallel, or less convergent, depending on conditions. In the third case the position of the image produced of a given object will be farther away from the convex lens than when it is used alone. In effect the image produced by the converging lens may be considered a *virtual* object for the diverging lens, and the image produced by the combination as the real image of that virtual object. If the distances of the virtual object and its image from the diverging lens be known, its focal length may be determined, using the usual expression for lenses

$$\frac{1}{p_1} + \frac{1}{p_2} = \frac{1}{f},$$

due regard being paid to signs.

Set up a luminous object, such as a metal screen with holes drilled in it, back of which is placed a gas flame, a converging lens, and a ground-glass screen on which to get an image. After obtaining a sharp image place the diverging lens between the converging lens and the ground-glass receiving screen and find a new focus. From the two distances of the screen to the concave lens the focal length may be determined. Make eight different settings for the determination of the focal length sought, four with one face of the concave lens toward the screen and four with the lens reversed.

Find the radii of curvature of the lens surfaces by the method of Exp. A₁ and compute the index of refraction for the material of which the lens is composed.

Addendum to the report:

Show by diagram how to find the position and size of the image produced by the two lenses, explaining fully.

EXPERIMENT L₅. Magnifying power of a telescope.

Focus the telescope upon some large object, such as a scale, which contains sharply defined portions of equal length. The bricks in the wall of a building, or the pickets of a fence, will serve for this purpose. Looking through the telescope with both eyes open, the magnified image of the scale will be seen by one eye, while with the other the scale is observed directly. By a comparison of the two images the magnifying power is determined. For example, if one division of the image seen in the telescope covers ten divisions of the unmagnified image, the magnifying power is ten. To guard against errors due to a difference in the two eyes, it is best to use the left eye in observing the telescopic image as often as the right.

The magnifying power should be determined in this way when the object observed is at several different distances, ranging from a distance that is so great as to be practically infinite to the least distance for which the telescope can be focused. If any difference is found in the magnifying power,

the variation should be shown by a curve in which distances and magnifying powers are used as co-ordinates.

For each distance of the object observed the distances between the various lenses should be accurately measured when the telescope is focused.

Addenda to the report :

(1) Determine the focal length of each of the lenses, and compute the magnifying powers. Draw a diagram to scale to show the position and size of the various images in one case.

(2) Explain the cause of the variation in magnifying power with the distance of the object.

EXPERIMENT L₆. Magnifying power of a microscope and determination of the focal length of its lenses.

The "open-eye" method.

This method is similar to that described for the determination of the magnifying power of a telescope.

(1) Focus the microscope upon a finely divided scale and place another scale at the side of the instrument at a distance from the eye equal to the distance of distinct vision (about 25 cm.). By observing the scale with one eye and the image formed in the microscope with the other, the apparent size of the magnified image is determined. The ratio of this to the actual size is the magnifying power.

(2) Measure the distance between the object glass and eye-piece and determine the focal length of the latter by one of the methods of Exp. L₃. From a knowledge of the magnifying power it will now be possible to compute the focal length of the object glass.

(3) Construct a diagram to scale to explain the action of the instrument, showing the position and size of each image.

GROUP M: THE SPECTROSCOPE, DIFFRACTION GRATING, AND SPECTRUM.

(M_1) Index of refraction of a prism; (M_2) Flame spectra of the metals; (M_3) Distance between the lines of a grating.

EXPERIMENT M_1 . Measurement of the angles of a prism and its index of refraction by means of a spectrometer.

The spectrometer consists of a collimator C , a telescope T (Fig. 53), a table to carry a prism P , a divided circle, and two verniers 180° apart for reading angles. These parts are all supported on a heavy base and in such a way that all except the collimator may be revolved about a common axis.

The collimator carries a lens at its end nearest the prism table, and an adjustable slit in a draw tube (not shown in the figure) at the other end. The telescope is fitted with cross-hairs in the eyepiece. The instrument is fitted with clamps to fix the general positions of telescope and circle, and slow-motion screws for fine adjustment in making settings.

When the spectrometer is in proper adjustment, the plane in which the telescope revolves about the axis of the instrument is perpendicular to that axis and comprises the axis of the collimator; the axes of the telescope and collimator intersect in the axis of the instrument, for all positions of the telescope; the refracting edge of the prism is parallel with the axis of the instrument; and the telescope and collimator are focused for parallel rays. Before making measurements with the instrument, it must be put into adjustment to conform to the requirements given above, as outlined in the following numbered

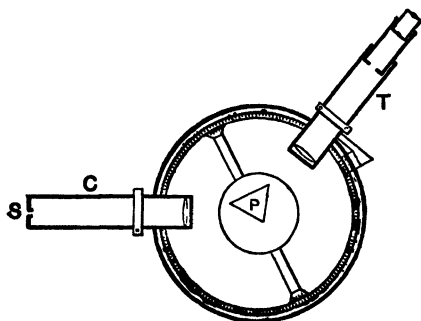

Fig. 53.

sections. The method of making these adjustments varies somewhat with the type of eyepiece used.

The Gauss eyepiece in its simplest form is composed of two lenses; two cross-hairs at right angles, their intersection being in the axis of the telescope; an unsilvered glass mirror set with its plane making an angle of 45° to the telescope axis in order to illuminate the cross hairs by reflecting light, which is permitted to enter the eyepiece through a hole in its side, toward the object glass. The illumination of the cross-hairs is best effected by placing a ground-glass screen between the light source and the opening in the side of the Gauss eyepiece.

Adjustments using a Gauss eyepiece.

(1) Focus the eyepiece so that the cross-hairs are distinctly seen. All other focusing is to be done without disturbing this adjustment by moving the eyepiece as a whole.

(2) To adjust the telescope for parallel rays, proceed as follows: Mount a piece of plane parallel glass (a piece of good plate glass will do) on edge on the prism table, with a little wax, so that the plane of either face is parallel to the line joining two of the leveling screws supporting the table, (Fig. 54). Turn the telescope until its axis is approximately perpendicular to a face of the glass plate. Illuminate the cross-hairs.

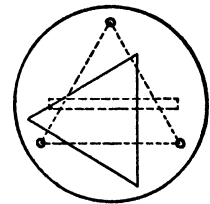

Fig. 54.

If light cannot be seen reflected from the plate, revolve the telescope about the axis of the instrument or change its elevation by means of its vertical adjusting screw, or both until reflected light is found. Change the position of the eyepiece until an image of the cross-hairs is distinctly seen and no parallax is noticeable, *i.e.* no relative motion of the cross-hairs and their images is observed when the eye is shifted about. The telescope is now focused for parallel rays.

(3) Turn the table carrying the glass plate until the vertical cross-hair and its image coincide. Vary the inclination of the

telescope by means of its vertical supporting screw until the horizontal cross-hair and its image coincide. Turn the prism table through 180° , bringing the vertical hair and its image into coincidence. If the horizontal hair and its image do not coincide, take out one half the variation by means of the third prism table leveling screw, and the remainder by means of the vertical telescope leveling screw. Turn the prism table through 180° and repeat the process. When the intersection of the cross-hair and its image coincide for either position of the prism table, the axis of the telescope is perpendicular to the axis of the instrument. This adjustment may be made, using a prism set as indicated in (5), the adjustment of one face being made in such manner as not to disturb the second, as explained in that section.

(4) The collimator may now be adjusted by illuminating the slit, turning the telescope to observe the slit through the collimator. Change the position of the slit by means of the draw tube until it is sharply focused with no parallax between its image and the cross-hairs. Bisect the slit with the horizontal cross-hair, using the vertical adjusting screw beneath the collimator. The collimator is now focused for parallel rays, and its axis is in the plane of revolution of the axis of the telescope and perpendicular to the axis of the instrument.

(5) The prism may now be set so that its refracting edge is parallel with the axis of the instrument. Mount the 60° prism, as in Fig. 54, with the base lines at right angles with the lines connecting the table leveling screws, the refracting edge being nearer the center of the table than the other edges. With the cross-hairs illuminated as noted, rotate the prism until one face containing the refracting edge is approximately perpendicular to the axis of the telescope. Make the face perpendicular to the telescope axis by bringing the intersection of the cross-hairs and its image into coincidence by means of the prism table leveling screws. Rotate the prism table until the other face containing the refracting edge may be viewed in the telescope. Bring the cross-hairs intersection and its image into coincidence

again by means of the table adjusting screw that will rotate the first face in its own plane. Test the first face again and make further adjustment if necessary in such manner as not to disturb the adjustment of the second face. Repeat the process until the intersection of the cross-hairs and its image coincide as viewed with either face toward the telescope. The instrument is now ready for use, it being assumed that the vertical cross-hairs and slit are parallel to the axis of the instrument. This may be tested by viewing the image of the slit in the telescope as reflected from either face of the prism, the refracting edge being turned toward the collimator.

Adjustments using the ordinary eyepiece.

The ordinary eyepiece is made up of two lenses, one carried in a drawtube, the other in a stationary tube which also contains a diaphragm supporting two cross-hairs at right angles, intersecting in the axis of the instrument.

(6) Adjust the eyepiece by means of the drawtube until the cross-hairs are sharply focused. This adjustment should not be disturbed in any subsequent adjustment of the instrument.

(7) To obtain parallel rays from the collimator to the telescope proceed as follows: Focus the telescope on some object which is so far away that the rays from it may be considered practically parallel. In focusing, the eyepiece is to be moved as a whole, and the parallax reduced to zero. Then turn the telescope so that it points directly at the collimator, and, without changing the focus of the telescope, alter the length of the collimator tube until the image of the slit, as seen in the telescope, is sharply defined with no parallax. Both telescope and collimator are now properly focused, and should not be altered during the experiment.

(8) Rotate the telescope about the vertical axis of the instrument until the vertical cross-hair and the image of the collimator slit coincide. By means of the vertical supporting screws rotate the collimator and telescope in a vertical plane

until their axes are coincident and the horizontal cross-hair bisects the slit.

(9) Place the prism on the table as indicated in (5), Fig. 54. Turn the refracting edge toward the collimator and view the image of the slit reflected from one face of the prism. By means of the leveling screws of the prism table cause the vertical hair to bisect the slit. Turn the telescope and view the image of the slit from the other side of the prism. Bisect the image of the slit with the vertical hair, taking care to use the leveling screw that will rotate the face, previously adjusted, in its own plane. Turn to the first position and readjust if necessary by means of the proper screw. If the slit image is bisected by both cross-hairs in both positions of the telescope, the adjustments are complete, and the instrument is ready for use. If the horizontal cross-hair does not bisect the slit, it may mean that the vertical hair and the slit are not parallel with the axis of the instrument. To make further adjustment rotate the slit about the axis of the collimator through a small angle, contraclockwise if the horizontal cross wire is too high when the slit is viewed from the right-hand face of the prism, or too low if viewed from the left-hand face, and clockwise if the opposite is true. View the slit direct, again bringing the vertical hair parallel with the slit. Adjust the prism again as before, and repeat until the proper adjustment is obtained.

I.

To determine the angles of a prism.

After the spectrometer has been adjusted as described above, place the prism near the center of the graduated circle, with its refracting edge turned toward the collimator (Fig. 55). Turn the telescope until the slit is seen by reflection from one face of the prism, and adjust the position of the telescope until its cross-hair coincides with the image of the slit. Record the position of the telescope as read by both verniers. Then set

the cross-hairs in the same way upon the image of the slit, as reflected from the other face of the prism, position T' , and again read the verniers. The angle between the two positions of the telescope is then equal to twice the angle of the prism. Loosen the clamp securing the prism table to the spindle. Turn the table through twenty or thirty degrees and clamp again. Turn the graduated circle and table until the refracting edge is again turned toward the collimator. Clamp it and proceed as before. Make a third set of readings after having again made a change in the part of the graduated circle used to read the angle of the prism. Mount a second prism, whose angles are different, on the prism table and measure all the angles three times as indicated above.

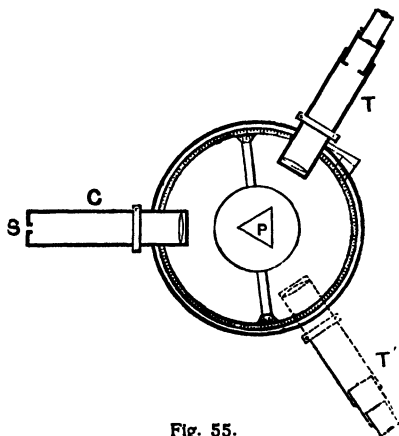

Fig. 55.

II.

To determine the angle of minimum deviation, and the index of refraction.

The spectrometer having been adjusted and the angle of the prism determined, the index of refraction may be found.

Up to this point in the experiment any source of light will serve equally well; but since different colors are bent by refraction in different degrees, it will now be necessary to use some monochromatic light. The most convenient light of a single color is that obtained by burning some salt of sodium in the Bunsen flame.*

* If light of a different wavelength were used, the index of refraction obtained would, of course, be different. Since this experiment is, however, merely intended to illustrate the use of the spectrometer, it will be found best to use the most convenient monochromatic light; viz. sodium.

Place the prism near the center of the horizontal circle, and in such a position that light from the collimator will be refracted through it and pass into the telescope. If, while observing the image of the slit in the telescope, the table which carries the prism is slowly turned, the image will be seen to move across the field, and it may be necessary to shift the position of the telescope in order to keep it in sight. In this way the prism can be set by trial to the position which causes the light to deviate least from its original direction on leaving the collimator. When this position is reached, a slight motion of the table in either direction will cause the image to move toward a position of greater deviation. When this setting is made as accurately as possible, bring the vertical cross-hair into coincidence with the image of the slit, and take the reading of the verniers.

Without disturbing the position of the graduated circle turn the telescope and set the vertical cross-hair on the slit viewed directly, removing the prism if necessary, and read both verniers. The differences of the readings of the verniers in the two positions gives the angle of minimum deviation. Make another setting for the angle of minimum deviation. Then turn the prism so that the light enters the opposite face, using the same refracting edge, and proceed as before, making two sets of readings. In this way find the angle of minimum deviation for one angle of each prism.

From the angles of the prisms and their angles of minimum deviation the indices of refraction are to be computed from the formula

$$\mu = \frac{\sin \frac{1}{2}(\delta + \alpha)}{\sin \frac{1}{2} \alpha}, \quad (188)$$

in which α is the angle of the prism, δ the angle of minimum deviation, and μ the index of refraction.

Addenda to the report :

(1) Prove that the angle turned through by the telescope in measuring the angle of the prism by the method in (I) is equal to twice the angle to be determined.

(2) Show that the index of refraction is the ratio of the velocities of light in the two media considered.

(3) Show that for minimum deviation the angle of incidence is equal to the angle of emergence.

(4) Show that equation 188 is true.

EXPERIMENT M₂. Study of various bright line spectra.

When a ray of light passes through a prism it will be bent from its path and, if made up of different wave lengths, each wave length will have its own emergent ray. If the incident ray be made up of parallel light, the separate emergent rays will be made up of parallel light. If a lens be placed in the path of the emergent light, it will focus the various wave lengths on the screen and a spectrum will be produced. The type of spectrum will depend upon the source of light. Glowing solids and liquids give continuous spectra, glowing vapors and gases usually have bright line spectra. Dark line spectra are produced by the absorption of particular wave length of the incident light depending on the nature of the vapor or gas. The bright line and dark line spectra are characteristic of the various gases producing them.

It is the object of this experiment to study the spectra of different substances when giving their bright line spectra. It is to be noted that a given gas will give out different bright line spectra depending on conditions of excitation as in the flame spectrum, the spark spectrum, the vacuum tube spectrum, and the arc spectrum. The first three types may be used in the experiment given below.

The study will be made with the spectrometer, using a simple prism. Since the spectrum produced by a given prism depends on its angle and material, it is necessary to know the dispersion and deviation produced by it; that is, to know its calibration. If the calibration be not known, the first part of the experiment will consist in such a determination, after which the spectra of various unknown substances may be studied.

I.

The calibration of a prism.

The spectrometer should be adjusted, as in Experiment M₁. The slit should be narrow in order to get as pure a spectrum as possible, the spectrum seen in the telescope being made up of images of the slit, one for each wave length; consequently the narrower the slit the less the overlapping. The calibration may be made by reference to the Fraunhofer lines. To accomplish this, the slit should be illuminated by bright daylight, or direct sunlight, and adjusted until the dark lines in the spectrum are clearly seen. The prism is then set to the position of least deviation for the *D* line, and the angular position of the telescope is observed for several of the more prominent lines. The wave lengths corresponding to these lines being known, a curve can now be constructed, in which angles of deviation are taken as abscissas, and wave lengths are ordinates. By reference to this curve, the wave length corresponding to any observed deviation is readily determined.

Another method which may be more convenient is by means of the spark, vacuum tube, or flame spectrum, or any combination of them. To produce the spark or vacuum tube spectrum, the vacuum tube containing a known gas or the spark gap between the ends of two pieces of a pure metal, between which an electric spark is to be produced, is to be placed directly in front of the collimator slit. The terminals of the vacuum tube or the two pieces of metal are connected to the secondary of an induction coil, which, when properly excited, will produce the desired discharge. Better results may sometimes be obtained if a small Leyden jar be put in multiple with the spark gap. The prism having been set at minimum deviation for sodium, the positions of several bright lines are to be located and read on the verniers, taking care not to disturb the setting of the prism. If flame spectra are to be used in calibration, a Bunsen burner is placed immediately in

front of the slit and the salts introduced into the colorless flame, using a wire of platinum supported on a glass rod. The positions of the bright lines are to be determined as in case of the spark or vacuum tube discharge. A good combination to use is the flame spectra of sodium and potassium, the vacuum tube spectrum of hydrogen and the spark spectrum of lead. The chlorides or carbonates of the salts are generally used in producing the flame spectra.

A suitable calibration may be based on the following table:

| Element | Spectrum | Color | Wave length in 10^{-8} cm. |
|---------|-------------|--------------|---------------------------------|
| K | Flame | Red | 7669 |
| Pb | Spark | " | 6657 |
| H | Vacuum tube | " | 6563 |
| Na | Flame | Yellow | 5893 |
| Pb | Spark | Yellow Green | 5608 |
| " | " | Green | 5373 |
| " | " | " | 5046 |
| " | " | " | 5006 |
| H | Vacuum tube | Blue Green | 4862 |
| Pb | Spark | Violet | 4387 |
| H | Vacuum tube | " | 4341 |
| Pb | Spark | " | 4245 |
| " | " | " | 4058 |

Plot a curve using wave lengths as abscissas and deviations from the sodium line as ordinates.

II.

Study the spectra of the substances furnished, determining the wave lengths of their bright lines and mapping their spectra on the same sheet, arranging the substances one below the other with their bright lines located to scale from left to right.

A most instructive method of mapping bright line spectra is that employed by Lecoq de Boisbaudran in his work on the

spectra of the metals.* An example is given in Fig. 56. As will be seen from the diagram, each spectrum is mapped twice, once above and once below the median line. The former gives the normal, the latter the prismatic spectrum of the substance in question. This method should be employed in reporting upon the results of this experiment for one element having several lines.

Considerable difficulty is sometimes met with in working with flame spectra in obtaining sufficient permanence and brilliancy for accurate observation. To obtain the best results the

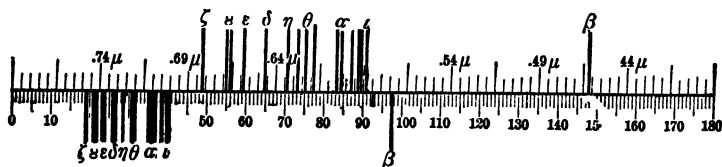

Fig. 56.

methods of heating must be suited to the salt used. In some cases, a small amount of the salt, when placed on a wire and heated in the flame, will form a bead which lasts for a considerable time and gives a good spectrum. In other cases the supply of salt will need to be constantly renewed. A piece of asbestos, or wire, which has been moistened by a strong solution of the salt, will sometimes give good results. In general, the results will be more satisfactory when the flame is quite hot. For this reason, the substitution of a blast lamp for the ordinary Bunsen burner is sometimes advisable. The observations can usually be made more rapidly if one observer devotes his attention to keeping the flame in proper condition, while another observes the spectrum.

EXPERIMENT M₃. Determination of the distance between the lines of a grating by the diffraction of sodium light.

The object of this experiment is to illustrate the principles involved in the formation of spectra by a diffraction grating.

* Lecoq de Boisbaudran, Spectres Lumineux, Paris, 1874.

There are two types of gratings, the reflection and the transmission grating. The transmission type is used in this experiment. It consists of a plane glass plate on which are ruled parallel lines quite near together. The ruling is done with a dividing engine. The spaces between the rulings act as parallel line sources of light. If parallel monochromatic light from a slit be incident upon the grating, each grating space being parallel to the slit may be taken as a source of a new disturbance sending out like cylindrical waves in all directions. Planes may be passed tangent to these new wave fronts such that the difference of path from any two adjacent wave fronts is equal to zero, one, two, three or more wave lengths. These planes may be considered as wave fronts of parallel light which may be focused on a screen by a converging lens, giving a series of linear images of the source. The central image corresponds to zero difference of path. The first image to the right or left of the central image corresponds to a difference of path of one wave length and is called a spectrum of the first order. The second image to the right or left corresponds to a path difference of two wave lengths from consecutive grating spaces and is said to be a spectrum of the second order. The order of the spectrum indicates the path difference between consecutive grating spaces, and the image on the screen. It is readily seen from Fig. 57 that

$$\frac{n\lambda}{d} = \sin \theta_n \quad (189)$$

in which n is the order of the spectrum, λ the wave length, d the grating space, or distance between corresponding parts of the lines and θ_n the deviation of the spectrum of the n th order from the normal to the grating. If white light be incident on the grating, a series of colored spectra will be found on either side of a white central image, with violet nearest the central image and progressing through all the colors of the spectrum to red at the outside.

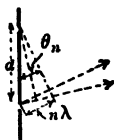

Fig. 57.

The grating may be used with a spectrometer to measure the angular deviation, but in the following experiment very simple apparatus is to be used.

The apparatus consists of a horizontal arm, which may for convenience be provided with a scale, mounted upon a suitable support, and having at its center a narrow vertical slit which may be illuminated by sodium light. To obtain the pure yellow light of sodium it is only necessary to place a wire carrying a bead of some sodium salt in the flame of a Bunsen burner; or to wrap some asbestos paper around the burner tube, permitting it to extend above the tube and saturating it with some sodium

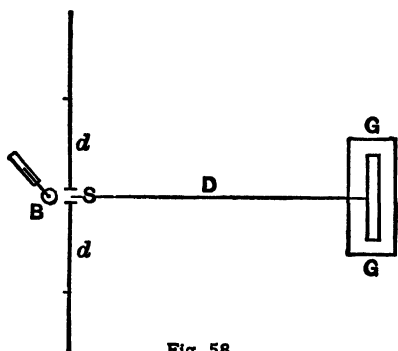

Fig. 58.

salt solution. The grating to be studied is placed in front of the slit with its rulings vertical, and should be mounted on some support, so that its distance from the slit can be varied.

On looking through the grating, several images of the slit will be seen on either side, the distance between these

images depending upon the distance apart of the lines of the grating. By measuring the distance between the grating and the slit (D , Fig. 58), and the displacement of one of the images d , the angle through which the light is bent by diffraction can be determined. From this angle, and the distance between the lines of the grating, the wave length of sodium light is to be computed.

In measuring the displacement of the images the following method will be found convenient: Adjust a small rider, which can be placed on the horizontal arm, until it coincides with the corresponding image on the opposite side of the slit. The distance between the two riders is then equal to twice the displacement of the image. Sometimes in a dimly lighted room,

if the images are bright enough, the positions of the various images may be read directly when looking through the grating. Read the positions of five images on each side of the central slit, if possible; for each of three positions of the grating, making D vary by about equal amounts for values not less than 80 nor more than 140 centimeters. Knowing these distances, compute the angular deviation and the value of the wave length of the monochromatic source used. Make readings in a similar manner for a grating for which the distance between the lines is to be computed, using the wave length determined by the use of the grating whose grating space is known.

Addenda to the report :

- (1) Explain what is meant by deviation and dispersion.
- (2) Prove the equation for the grating.

CHAPTER V.

GROUP N: PHOTOMETRY.

(N) *General statements ; (N₁) Horizontal distribution of light by the Bunsen or the Lummer-Brodhun photometer ; (N₂) Variation of candle power with voltage. Use of the Weber photometer.*

(N) If the properties of a medium transmitting energy are the same in all directions, the amount of energy transmitted across equal areas from a small source is inversely proportional to the squares of the distances of the areas from the source. This principle, applied to light, is stated as follows: The intensity of illumination produced on a surface by a light source is proportional to the brightness L of the light source, and inversely proportional to d^2 , d being the distance from the source to the surface,

$$I = \frac{L}{d^2}. \quad (190)$$

If two sources L_1 and L_2 produce equal intensities of illumination on a given surface, then the relative brightness of the two sources may be compared, or the brightness of one source determined in terms of the other.

$$I = \frac{L_1}{d_1^2} = \frac{L_2}{d_2^2}, \quad (191)$$

$$L_1 = L_2 \frac{d_1^2}{d_2^2}. \quad (192)$$

The comparison of light sources and the study of the distribution of light is called photometry. Instruments used to compare intensities of illumination are called photometers.

PHOTOMETERS. — Three different kinds of photometers are used in performing the experiments which follow; namely, the Bunsen, the Lummer-Brodhun, and the Weber.

In the Bunsen photometer a screen of white paper (D , Fig. 59), a portion of which has been made translucent by the application of oil, is placed in a blackened box (technically

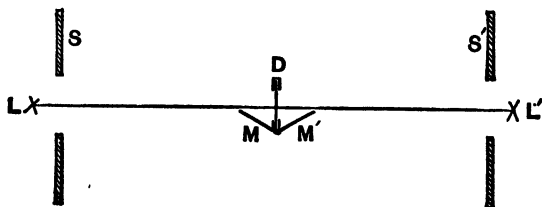

Fig. 59.

called the carriage), and mirrors, M , M' , are adjusted so that both sides of the paper may be observed at the same time. By means of openings in the carriage, light is admitted from the two sources whose intensities are to be compared. The carriage being placed between the two lights, each face of the screen is illuminated only by light from the source toward which it is turned, while the translucent portion of the paper receives light from both sources. In using the instrument, the carriage is shifted in position until both sides of the screen are seen to be equally illuminated. The distances of the two lights from the screen are then measured, and the relative intensities of the two sources are computed by the law of

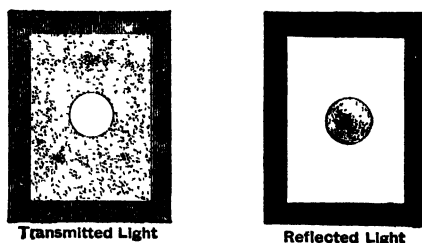

Fig. 60

inverse squares. The translucent spot on the screen merely serves to locate the position of equal illumination with greater accuracy than could otherwise be obtained. If the adjustment is not quite correct, this spot will appear dark on one side and bright on the other (see Fig. 60); but when the proper position

has been found, it will almost entirely disappear. Since the screen may not be alike on its two sides the photometer should be reversed in any set of readings, so that both faces be exposed to each source and the mean reading for the set used in making computations.

The Lummer-Brodhun photometer (Fig. 61) consists of a blackened box or carriage, through two opposite sides of which are cut holes which permit light from the sources to be compared to fall on the two sides of a white opaque screen S , which has matte surfaces. The two sides of the screen are viewed at the same time through the observing telescope T , by

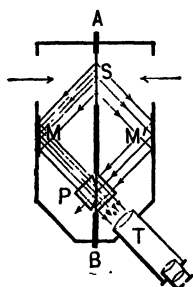

Fig. 61.

means of properly placed mirrors M and M' , and a Lummer-Brodhun cube P . The cube is made up of two 90° prisms. On one of the prisms a part of the face opposite the right angle is cut away. The remainder of this face is then brought into optical contact with the corresponding face of the other prism, and placed in the carriage as indicated in the figure. Light from the mirror M may pass through the area of contact of the prisms into

the telescope, but the light incident outside of this area is absorbed by the blackened ground surface. Light from the mirror M' passes through the area of contact of the two prisms and does not enter the telescope. But that light striking the polished surface of the right-hand prism is totally reflected, and enters the telescope. Thus the two fields are observed side by side, at the same time, in the telescope. If the two sources are emitting the same quality of light and the two paths from the like surfaces of the screen S are similar, the brightness of the sources may be compared, as in the case of the Bunsen photometer, by moving the carriage until the observed field is uniform. To guard against errors due to dissimilarity of path, settings may be made first with one face of the screen exposed to one source of light, then the other face

exposed to the same source by rotating the carriage through 180° about the horizontal axis AB , perpendicular to the photometer bar. If the sources are not of the same quality, the estimation of equal intensities becomes a much more difficult matter, but the process is the same as with sources of like quality.

The Weber photometer is a portable instrument which makes use of the Lummer-Brodhun cube described above. It consists of two tubes (Fig. 62), blackened on the inside to absorb light incident on these surfaces, joined together with their axes at right angles. The center of the Lummer-Brodhun body B is placed at the intersection of the two axes. At one end of the principal tube there is an observing telescope T , and at the other end an opening to receive light from the source S . At this end there is also an opening into which absorption screens or test plates P may be inserted. At the outer end of the side tube there is placed the "comparison lamp" L . Within the side tube there is an adjustable "comparison screen" C , whose position is indicated by an index moving over a scale on the outside of the tube. Equality of fields is obtained by moving the "comparison screen" C along the axis of the side tube.

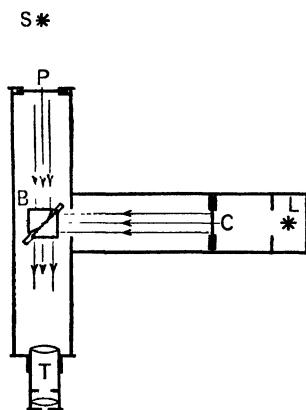

Fig. 62.

By using different absorption screens at P , light sources of greatly varying intensities may be compared, or the absorbing power of substances which are nearly transparent may be determined. To accomplish this, measure the intensity of any source as seen direct; then interpose the substance to be investigated, and see how much the light is diminished. From the two measurements the percentage absorption can be computed. Investigate in this way the absorption of sheets of glass of dif

ferent thickness, and of cells containing various liquids. It must be remembered, however, that some of the light which is apparently absorbed is really lost by reflection. If it is desired to separate the effects of reflection and absorption, more elaborate methods will be necessary.

The Weber photometer is suitable for many purposes. It is often used as an illuminometer.

LIGHT STANDARDS. — Although the brightness of light sources is expressed in candle power, the candle is seldom used as a standard of comparison. Many suggestions have been made regarding what sources to use as standards of comparison, and the question is even yet a debatable one. Among the requirements for a standard light source that of reproducibility is of prime importance. The two most important flame standards in use at the present time are the pentane lamp and the Hefner lamp. The Hefner lamp burns pure amyl acetate. The wick tube has a certain prescribed length and diameter. There is a flame gauge mounted on the lamp in order to get a flame of a certain height. The following precautions should be taken in using the Hefner lamp.

The lamp should be well cleaned, filled, and the wick should be trimmed square off.

The height of the flame should be carefully adjusted until the image of its tip exactly meets the line on the optical sight. The height of the flame is then 40 mm. and the intensity of the light is normal. Measurements should not be begun until the lamp has been burning at least ten minutes. Draughts in the room should be avoided and the lamp used without boxing it up. Two observers are necessary for the best use of the lamp, one to make the photometric observations and the other to indicate the moments when the height of the flame is exactly right.

After using, and while the lamp is still hot, the upper part of the wick tube should be wiped clean with a soft cloth. The brightness of the Hefner lamp is influenced by the barometric

pressure, the amount of CO_2 , and of water vapor in the air. Usually the effects of the variation of barometric pressure from the normal, and of the amount of CO_2 present in a well-ventilated room are so small as to be negligible. In accurate work it is necessary to take account of the effect of water vapor present. The normal state is taken as 8.8 liters of water vapor per cubic meter of air, the lamp then having 0.9 candle power in terms of the new International Standard. The following relation has been found to hold regarding intensity and water vapor :

$$y = 1.049 - 0.0055 x, \quad (193)$$

in which y is the intensity in terms of the Hefner unit, and x is the number of liters of moisture per cubic meter of dry air. The factor x depends on the temperature and the relative humidity (the percentage of saturation of the air). It is equal to the mass of saturated water vapor per cubic meter times the relative humidity divided by the mass of saturated water vapor per liter. All of these factors depend on temperature. Experimental determinations have been made of them and in terms of these determinations equation 193 may be written

$$y = 1.049 - 0.0055 \frac{m}{m_e} h, \quad (194)$$

in which m , m_e , and h are the masses of saturated vapor per meter and liter, and the relative humidity respectively. The factor $0.0055 \frac{m}{m_e}$ may be computed for various temperatures and a curve plotted using temperatures and it as co-ordinates, as shown in Fig. 63. Having found the relative humidity (see table 10), obtain the value of the factor $C \left(= 0.0055 \frac{m}{m_e} \right)$ from the curve for the proper dry bulb reading, and compute the value of y .

The standards now in most general use are carefully calibrated glow lamps. These standards are used to calibrate

secondary standards, which in turn are used to determine the candle power of the working standards of comparison. The above process is necessary, owing to the variation of candle power with voltage, age, or service. A standard lamp should be carefully brought up to its proper voltage and should never be carried above it, even for an instant. The lamp should be

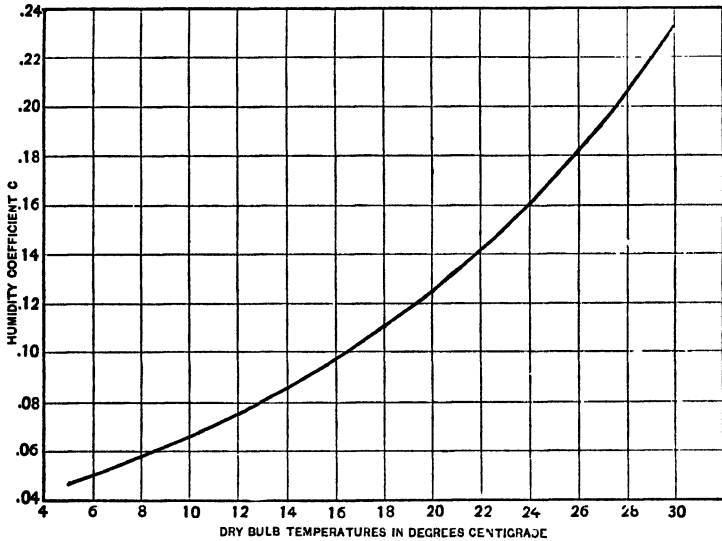

Fig. 63.

kept burning only when in actual use in making comparisons, and should not be used longer than a specified time in the aggregate.

In general it is best to use a lamp at constant wattage rather than constant voltage.

EXPERIMENT N₁. Horizontal distribution of light by the Bunsen or Lummer-Brodhun photometer.

Set up a Hefner lamp, a Bunsen or Lummer-Brodhun photometer, and a bat-wing gas burner, capable of being rotated about a vertical axis through definite angles, on a photometer bar. The gas burner should be connected to a line in which

there is a water manometer in order to determine the gas pressure.

Adjust the height of the flame of the Hefner lamp to the proper value. Set the gas burner so that the plane of the flame is at right angles to the axis of the photometer bar. Adjust the height of the flame to that which gives steadiness without spluttering. Note the manometer pressure. Change the position of the photometer carriage to give equality of illumination on both sides of the screen and make the proper photometer bar readings.

After each reading, the carriage should be shifted 20 or 30 cm., in some cases to the right and in others to the left of the proper setting and then brought back again, without reference to the previous reading, until the two sides of the screen appear to be equally illuminated. The uncertainties of the observation, together with slight variations in the intensities of the two lights, will make it impossible to obtain coincident settings, but after a little practice the successive readings should agree to within three or four per cent. Constant differences are often observed between the settings of different persons. These are due to differences in the eye, and cannot be avoided. Make at least two readings with each face of the screen toward the standard lamp. It is found to be advantageous to use black screens, which may be mounted on the photometer bar, to keep direct light out of the eyes. Measure the candle power of the gas flame for different angular positions, at intervals of 15° from 0° to 180° . In making computations, assume the candle power of the Hefner lamp as 0.9.

The candle power of the Hefner lamp should really be corrected for moisture of the air. This correction, however, may be omitted for purposes of this experiment, unless otherwise directed. Be careful to keep the Hefner flame at exactly the right height.

Also measure the candle power of the flame for ten pressures

partly above and partly below normal for one angular position only.

Plot a curve, using polar co-ordinates, showing the distribution of intensity around the gas flame. Also compute the percentage difference between maximum and minimum candle power. Plot another curve, showing the relation between candle power and gas pressure.

EXPERIMENT N₂. Variation of candle power with voltage. Use of the Weber photometer.

There are numerous ways of calibrating and using the Weber photometer, but when it is not desired to measure the absorption coefficients of the several screens used, the following simple method may be used :

Set up an incandescent lamp of known candle power at a measured distance (1 or 1.5 m.) in front of the "test plate" of the photometer. (See Fig. 62.)

The plane of the filament should be perpendicular to the photometer axis. Adjust the voltage around the lamp, and also adjust the height of the "comparison flame" to the prescribed value and see that these are kept constant during the experiment. Then adjust the "comparison screen" until the field of the photometer appears uniform. Note the position of the index on the photometer scale. The intensity of illumination produced by the standard lamp on the test plate is L/D^2 meter candles, where L is the candle power of the standard lamp and D is distance in meters from the test plate. Obtain in this way three different illuminations on the test plate and the corresponding positions of the comparison screen for a balance, the latter positions being well distributed over the photometer scale by proper choice of illuminations. It will readily be seen how this process may be worked backward and the candle power of any unknown lamp measured.

Now replace the standard lamp by a 50-volt carbon filament incandescent lamp and, by use of the calibration just described,

measure the candle power and current of the 50-volt lamp at the following voltages : 40, 42, 44, 46, 48, 50, 51, 52, 53, 54, 55.

Plot four curves with co-ordinates as follows :

1. Candle power — Volts.
2. Candle power — Amperes.
3. Candle power — Watts.
4. Candle power — Watts per candle power.

CHAPTER VI.

GROUP O: SOUND.

(O₁) *Measurement of pitch by the syren; (O₂) Wave length by Koenig's apparatus; (O₃) Resonance of columns of air with determinaton of the velocity of sound; (O₄) Velocity of sound in brass; (O₅) The sonometer; (O₆) Study of the transverse vibration of cords, Meldc's method.*

EXPERIMENT O₁. Measurement of pitch by the syren.

This experiment consists in the determination, by means of a syren, of the pitch of an organ pipe, first when closed at one end and then when open. Each determination should be made several times. Two observers are needed to make these measurements successfully, one devoting his attention to keeping the syren in unison with the pipe, while the other operates the counter and observes the time. To form an estimate of the degree of accuracy that is attainable, several measurements should be made with a tuning fork of known pitch before beginning observations with the pipe.

EXPERIMENT O₂. Interference and measurement of wave length by Koenig's apparatus.

In the form of apparatus used a manometric capsule (m_1, m_2) is attached to one end of each of two tubes. The opposite ends of the tubes are brought together at a common opening (Fig. 64), where some sounding body, such as a tuning fork or organ pipe, is to be placed. The two tubes are initially of the same length, but one of them (L_2) is capable of adjustment so that its length can be increased by about 50 cm. From each of the two capsules a tube (g_1, g_2) leads to a small gas jet.

The latter will be set in vibration when the membrane of the capsule is disturbed, and can be observed in a revolving mirror. There is also a third jet attached to g_3 which is connected, by tubes of equal length, to both capsules; so that if a pressure or

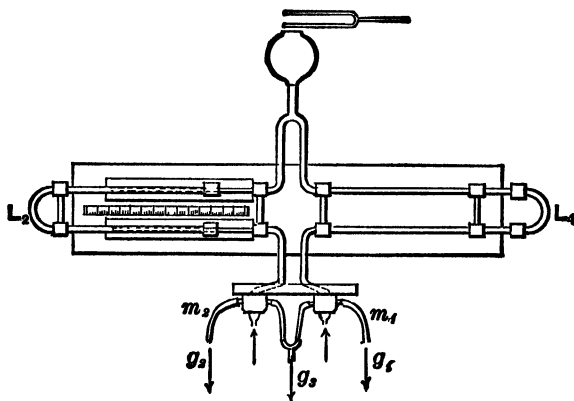

Fig. 64.

condensation is sent to it by one of the capsules at the same time that an equal rarefaction is sent by the other, the two acting on the flame at the same instant will not affect it. Each of the single jets will, however, still show the disturbance. In order that a condensation may exist at one capsule at the same time that a rarefaction exists at the other, it is obvious that the two tubes must differ in length by one half the wave length of the sound that is producing the disturbance, or by some odd multiple of a half wave length. This can be brought about by sliding the movable tube in or out. When the proper adjustment is obtained, the jet that is connected with both capsules should show a minimum disturbance. It will not be found possible to produce complete quiescence in the image of g_3 , such as is indicated in Fig. 65.

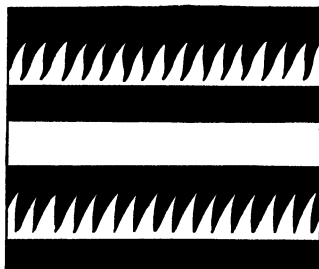

Fig. 65.

Care must be taken to have the tubes which supply this jet of the same length, and also to have the pressure of gas the same in each. To adjust the pressure, pinch shut one of the tubes, and note the height of flame due to the other; then pinch the second tube and release the first, and adjust the supply of gas until the height of flame is the same in both cases.

The wave length being determined as described above, and the pitch of the fork used being known, the velocity of sound can be computed. The result obtained should be compared with the velocity given by the formula

$$v = 332 \sqrt{1 + \frac{1}{273} t}, \quad (195)$$

where t is the temperature of the room. If the sounding body used is of unknown pitch, the wave length can be determined as before, the velocity of sound obtained from the above formula, and from these two quantities the pitch can be computed.

EXPERIMENT O₃. Resonance of columns of air and determination of the velocity of sound.

The length of a closed pipe giving its fundamental in resonance with a source of sound such as a tuning fork held near its open end, is not strictly proportional to the wave length of the sound produced. The length of the pipe must have a correction factor added which is proportional to the radius of the pipe, due to the disturbance of the open end. Consequently, to find the velocity of sound by the resonant air column method, it is necessary to find the correction factor or to find the pipe of zero radius which would give resonance.

A satisfactory arrangement for performing this experiment is to use a vertical cylinder 10 or 12 cm. in diameter and 70 or 80 cm. long, closed at its lower end, a set of five tubes varying from 1 to 5 cm. in diameter and about the length of the cylinder, and two tuning forks of suitable frequencies. The vertical cylinder is to be filled with water to within 3 or 4 cm. of the top. Place one of the tubes within the cylinder, leaving a short

length above the water surface. Cause one of the forks to vibrate, and holding it a constant short distance above the tube, raise or lower the tube until a point of resonance is found. Clamp the tube in position and measure the distance from the open end of the tube to the water surface. Repeat the above operation three or four times in order to get a good average. With care settings may be made with variations of only a few millimeters. If the tube be long enough, find the other possible points of resonance in the same manner. This process is to be followed with each tube for each fork. Note the temperature of the air.

The correction to be added to the mean resonance lengths obtained for any tube may be taken as 0.6 of the radius for that tube. The averages of the appropriate means may be used to compute the velocity of sound. As a check upon the results the velocity of sound may be computed for the temperature of the air at the time of the experiment, upon the assumption that the velocity at 0° is 332 m. per second, and that the velocity of sound increases 60 cm. per second for each degree rise of temperature on the centigrade scale.

Plot points on cross-section paper for each fork, using tube radii as abscissas and resonance lengths as ordinates. Locate straight lines best suiting the points plotted, continuing them backwards to the Y axis. Interpret the meaning of the slope and the Y intercept and find a value of the velocity of sound based on each curve.

The report should contain a full explanation of the resonance phenomena observed, with derivation of formulas.

EXPERIMENT O₄. Velocity of sound in brass. Kundt's method.

A brass rod about a meter long, Fig. 66, is placed in a horizontal position, and firmly supported at its center. To one end of the rod is fastened a disk of cardboard or cork, whose diameter is almost equal to that of a glass tube in

which it is inserted. The opposite end of this tube is closed by means of an adjustable piston, so that the length of the air column in the tube can be altered. On setting the rod into vibration (by rubbing its free end with leather covered with rosin), the air in the tube will also vibrate, and by placing some

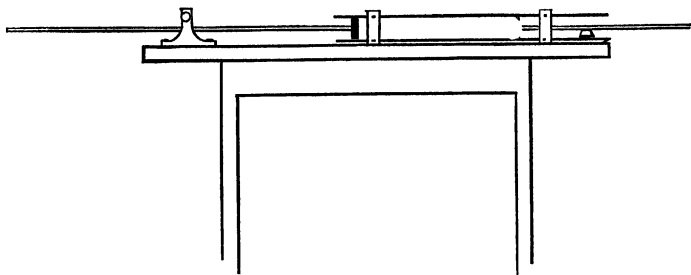

Fig. 66.

light powder in the tube (such as lycopodium or cork dust), these vibrations are made evident to the eye. If the length of the tube is properly adjusted, the dust will be seen to distribute itself regularly in little heaps, these heaps corresponding to nodes in the stationary waves set up in the air. Frequently the dust figures are similar to those shown in Fig. 67.

The experiment consists in so adjusting the length of the air column as to make this regular distribution of the dust as marked as possible.

Determine the distances between the first and last nodes, as indicated by the dust heap, the second and next to the last and



Fig. 67.

so on, noting in each case the number of vibrating segments included between the nodes considered. From the sum of these distances and of the number of vibrating segments find the average length of a vibrating segment. From it and the velocity of sound in the air within the tube the frequency may be determined; and also the frequency of the longitudinal vibra-

tions in the rod. Since the rod is clamped at its center, the wave length of the vibrations produced in it is equal to twice the length of the rod. Shake up the dust in the tube, change the position of the plunger on the end of the rod by moving the tube, and proceed as before, making in all three sets of readings. Having the wave lengths of the same note in air and in brass, the ratio of the two gives the ratio of the two velocities of sound.

To compute the velocity of sound in air at the temperature of the experiment, make use of the formula $v = 332 \sqrt{1 + \frac{t}{273}}$. Find the mass and dimensions of the rod and compute Young's Modulus for material of the rod, remembering that

$$\text{the velocity} = \sqrt{\frac{\text{elasticity}}{\text{density}}}.$$

The apparatus may be used to find the velocity of sound in any other gas, the above being considered a calibration.

EXPERIMENT O₅. The sonometer.

All the laws of vibrating strings or wires may be expressed by the formula

$$N = \frac{1}{2rl} \sqrt{\frac{T}{\pi d}}, \quad (196)$$

where N is the number of complete oscillations per second, l the length of the vibrating segment of the string, r its radius, d its density, and T the tension to which the string is subjected. This formula may also be put in the form

$$N = \frac{1}{2l} \sqrt{\frac{T}{m}}, \quad (197)$$

where m is the mass of unit length. This form of the equation is often the more convenient.

The object of the experiment is to verify this formula experimentally. The apparatus used is a sonometer (Fig. 68), which consists of a long wooden box, upon which may be stretched two or more wires. One of these wires is stretched by turning

a key. The tension of the other one must be known. To secure this, one end of the string is fastened to the box, and the other end to a lever which moves about a knife-edge as an axis. From the other end of this lever weights are suspended. If the two lever arms are made equal, the tension of the string is equal to the weight suspended. The length of the vibrating segment of either of these strings may be varied by changing the position of a movable bridge.

In performing the experiment suspend enough weights to give the string to be tested the desired tension. By varying the

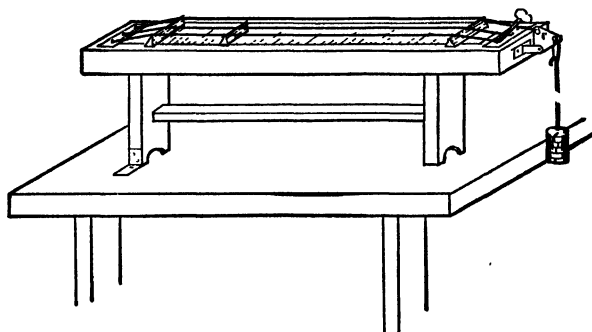

Fig. 68.

position of the movable bridge make three independent determinations of the length of a segment of the string under investigation which will vibrate in unison with a tuning fork of known pitch. In making computations use the mean length. For two other tensions make sets of readings as indicated above. Having measured the values of r , l , T , etc., compute the pitch of the string from the formula given above, and note how closely the result agrees with the known pitch of the fork. The law should be tested in this way for at least three strings of different diameter and density, and several forks should be used with each string.

On account of the great difference in quality between the note of the string and that of the fork, great care must be used in adjusting the former. If the ear is untrained, a mistake of an octave is not unusual. It may be found advantageous to

put light paper riders on the string and bring the stem of the vibrating fork in contact with the top of the sonometer. As the bridge is moved to that position giving resonance the rider will be agitated violently and may jump off. In such cases it is well to approach the resonance length from both too long and too short a length of string, taking the mean length as that giving resonance.

EXPERIMENT O₆. The study of the transverse vibration of cords by Melde's method.

If one end of a horizontal cord be fastened to a prong of a heavy tuning fork, which is caused to vibrate, while the other end passes over a bridge and a pulley to a scalepan or other arrangement for suspending weights, it will break up into vibrating segments when the tension is of the proper value. If the plane of the prongs be horizontal and the stem of the fork be parallel to the cord, when the prong moves in one direction the cord will move in the same direction, and when the direction of motion of the prong is reversed the direction of motion of the cord will be reversed; thus the frequency of the cord will be the same as of the fork. If the prongs and cord be in a horizontal plane but with the axis of the cord perpendicular to the fork stem, then the string will have one half the frequency of the fork. This may be explained as follows: suppose the prong to which the cord is attached move toward the bridge, the tension in the cord is reduced and the cord sags. A moment later the prong is moving in the opposite direction, the tension in the cord is increasing, the cord is moving up. The prong reaches the end of its excursion, the cord reaches its neutral position, but having inertia passes on through it, and as the prong moves again toward the bridge, the string moves up, becoming concave downward; thus the fork makes a complete vibration while the string makes a half vibration.

For a definite frequency, a certain cord will vibrate as a whole, at a definite tension. Let the tension be reduced. A

value will finally be reached at which the string will vibrate in two segments, since the frequency does not change. By still further reduction of the tension the string will break up into three segments, and so on.

If N be the number of vibrations per unit of time, L the length of the cord, n the number of segments, and V the velocity of transmission of an impulse transmitted to the cord, we have the familiar formula expressing the transverse vibrations of flexible cords :

$$N = \frac{n}{2L} V, \quad (198)$$

If P is the tension of the cord, s its cross section, and d its density, we have also

$$V = \sqrt{\frac{P}{sd}}. \quad (199)$$

Finally, if λ is the wave length, we may write

$$\lambda = \frac{2L}{n}, \quad (200)$$

$$V = N\lambda, \quad (201)$$

$$\sqrt{\frac{P}{sd}} = N \cdot \frac{2L}{n}, \quad (202)$$

$$N = \frac{n}{2L} \sqrt{\frac{P}{sd}}. \quad (203)$$

The experiment consists in setting up a heavy electrically driven fork and a braided silk fishline with a bridge, pulley, and appliances for varying the tension in the cord in accordance with the above discussion and making the following observations. For the first position of the fork noted above vary the tension in the cord until it is vibrating in one segment in unison with the fork. Note the applied tension and the distance between nodes. Change the tension until the cord breaks up into two vibrating segments. Note the tension, number of vibrating segments, and distance between the extreme nodes. Repeat the

process, obtaining three and then four vibrating segments of the cord.

Change the relation of fork and cord, making them correspond to the second case discussed above and again cause the cord to vibrate in one, two, three, and four segments, noting the corresponding tensions and lengths. Obtain the mass of the cord per unit length and solve for the frequency of the cord. Compare the frequency of the cord with that of the fork.

Discuss the derivation of the formulas in your report.

CHAPTER VII.

GROUP P: STATIC ELECTRICITY.

(P) *General statements*; (P₁) *Electrostatic induction*; (P₂) *The principle of the condenser*; (P₃) *The Holtz machine*; (P₄) *Further experiments with the Holtz machine.*

(P) **General statements concerning static electricity.**

Whenever a body or system of bodies becomes electrified, equal quantities of positive and negative electricity are produced.

Many experimental facts lead to the conclusion that the energy of electrification exists in the insulating medium between the bodies containing these two equal quantities of positive and negative electricity. These experimental facts prove that the insulating medium is in a state of strain. Therefore the energy of electrification is the potential energy of an electrical field, in an insulating medium, bounded by bodies containing what are called "charges of electricity."

If an electrified body or system of bodies be placed within a closed conducting surface, the charge of electricity on this surface is equal, and of opposite sign, to the charge of the body or system of bodies. This law has been deduced directly from experiment. However, it may be shown to be directly deducible from the following theorem.

Let F denote the resultant electrical force at a point on a small element of the surface of a charged body: the integral of the quantity FdA , taken over the entire surface of the charged body, is numerically equal to $4\pi Q$, in which Q is the number of units of electricity in the body.* This is known as Green's theorem.

* Gray, *Absolute Measurements in Electricity and Magnetism*, vol. 1, p. 10.

Another way of stating this fact is as follows: The number of lines of force, or of unit tubes of force, issuing from the surface of a body charged with Q units of electricity, is $4\pi Q$. These lines of force, or tubes of induction, must end on some other body or bodies. On the surfaces of the conductors where these $4\pi Q$ lines of force end, there must be Q units of induced electricity of the opposite sign to the electricity on the first conductor.*

To completely discharge a conductor, and cause to vanish the field surrounding it, it will be necessary for these two equal quantities of electricity of opposite signs to unite.

The conception of free and bound electricity helps to the understanding of this and other phenomena of static electricity. The term "free electricity," or "free charge," is applied to that portion of a charge which will escape to the earth, when the conductor containing it is connected to earth, while a bound charge is that portion which is held by the induction of some other near-by *insulated* charge.

Suppose A (Fig. 69) to be an insulated conductor charged with Q units of positive electricity. Suppose B to be a conductor which has been grounded and afterwards insulated. The charge Q induces on B , q' units and on the walls of the room, q'' units of negative electricity, such that

$$Q = -(q' + q'').$$

That part q' of the electricity induced on B is bound by the charge Q . None of it will escape to the earth, for its potential has been reduced to zero by grounding it. The charge q' on B binds, by induction, a *portion* of the charge on A ; so that if

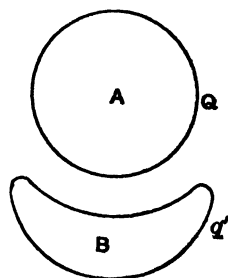

Fig. 69.

* This is more general than the second law above given, but it is based on the assumption that an electrical field does not extend indefinitely in a direction in which there are no charged bodies.

A were grounded, only a portion of the Q units of electricity would escape. That which escapes is free electricity; the remainder is bound by the negative charge on B .

It is very important to keep clearly in mind the distinction between the *character* and the *potential* of a charge of electricity. In the above example, before A was grounded, B was at zero potential, but it had a negative charge; after A was grounded, the potential of B became negative, although its charge was unchanged. A , however, was reduced to zero potential, but it still retained a positive charge.

Positive and negative electricity always exist at the positive and negative ends respectively of electrical lines of force; or, as some may prefer to put it, at the positive and negative boundaries of an electrical field of force. The potential of the body containing the positive charge must always be positive with respect to the body containing a negative charge at the other boundary of the field; but the potential of either or both of these bodies may be anything with respect to the earth, whose potential is usually taken as zero.

The potential of a conductor is positive, when, upon being grounded, positive electricity is discharged to the earth; when negative electricity is thus discharged, the potential is negative, and when no discharge occurs, the conductor is at zero potential.

It is a very instructive exercise to map out a field of force with equipotential surfaces and lines of force.* It is not difficult to do this in an approximate manner, if the student keeps clearly in mind the definitions, the fact that lines of force and equipotential surfaces are mutually perpendicular, and the fact that the surface of every conductor is an equipotential surface.

Let it be required to map a section of the field within a hollow conductor at zero potential, containing two insulated con-

* In this connection the beautiful maps of the electrostatic field at the end of the first volume of Maxwell's *Electricity and Magnetism* should be inspected.

ductors. One of these conductors (A) is positively charged, and the other has only an induced charge.

It will be found easier to draw the lines of force first.

(1) They must always be drawn between conductors of different potentials.

(2) They must issue from a conductor at right angles to its surface.

(3) Lines of force must always issue from a body containing a positive charge, and end on a body containing a negative charge.

If lines of force are drawn fulfilling these conditions, they will be as indicated in Fig. 70.* It may be assumed, approximately, that along the shortest distance between the two conductors the potential falls uniformly. Assume that the difference of potential between them is nine. Divide the distance into nine equal parts, and through each point of division draw a line, and continue it so that it is everywhere perpendicular to lines of force. Each of these lines must be a closed curve. And from definition, each of them must lie in an equipotential surface.

By definition, the same amount of work is done in carrying a charge from one point in an equipotential surface to any point in another equipotential surface. Therefore, the field

* The equipotential lines and lines of force in Fig. 70 were computed by C. D. Child.

This computation was made as follows: Known charges were supposed to be concentrated at points. A series of points were then found which had the same potential, according to the formula $V = \sum \frac{q}{r}$. All the equipotential surfaces, from 3 to 15 inclusive, were determined in this way. A conductor connected to the ground was then supposed to coincide with the equipotential surface 3. This reduced the potential of every point within by three units. A conductor was then supposed to surround a charge of +40 units, and coincide with the equipotential surface 12; while another conductor was supposed to surround charges of +10, -5, and -5 units, and coincide with the equipotential surface 3. These two conductors in no wise changed the potential of any point in the field of force, while it was perfectly allowable to suppose the charges within them to be transferred to their outside surfaces.

must be strongest where these surfaces are closest together. Strength of field is sometimes represented by the *number* of lines of force per square centimeter. Therefore, where the

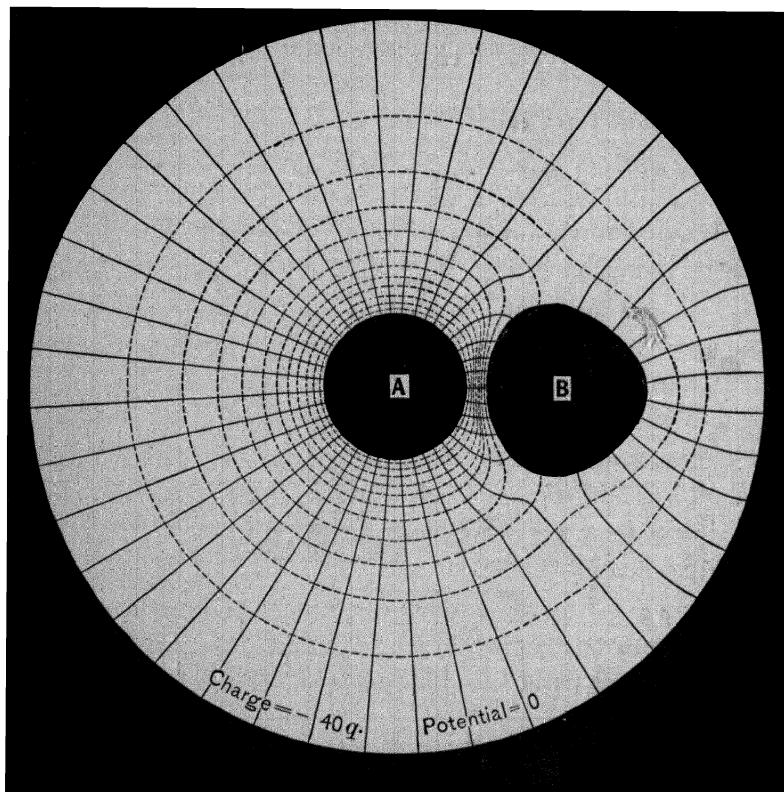

Fig. 70.

equipotential surfaces are closest together, the lines of force should be most numerous.

It should be noticed that one of the conductors (*B*) has lines of force issuing from it and also others ending on it. It follows that there is a positive and a negative charge on this conductor, although the whole of it is at the same potential.

Potential as used in electricity and magnetism is analogous to gravitational potential, in so much as it means work done to bring a unit pole to the

designated point in a magnetic field, or a unit charge to a point in an electric field, from a place where the field is zero; that is, from a point without the field, which is assumed to be of zero potential. This is analogous to the conception of potential energy; for, if sea level be assumed as a level of zero potential energy, a kilogram weight raised 10 meters above that level is said to have 10 kilogram-meters of potential energy and the gravitational potential of the point is called 10, since a unit mass was used. If for example a mass of 20 kilograms be moved from the sea level to a place where the gravitational potential is 50, the amount of work done would be 50×20 kilogram-meters, since the gravitational potential gives the amount of work that must be done on one kilogram to carry it from sea level to the point in question. Just as this potential energy is independent of path, so also are *magnetic* and *electric* potentials. Assuming always a positive unit pole or charge to be used, then as work is done against or by the magnetic or electrical forces, so is the sign of the potential arbitrarily taken as plus or minus.

Considering two points in a field of force as A and B , let V_a and V_b be the potentials at a and b ; $V_a - V_b$, the work per unit charge or pole required to move it from a to b . Therefore $V_a - V_b =$ average force per unit quantity times the length ab or $(I'_a - I'_b)/ab =$ average force per unit quantity or pole. When b is very close to a and the force does not change abruptly, we have

$$\frac{dV'}{dl} = I'_a. \quad (204)$$

In some cases we may proceed from a known relation between force and distance and find the potential at points required. As an example we may consider the potential at a point outside an isolated and insulated conducting sphere. For external points we may consider the entire charge as concentrated at the center of the sphere.

Then if r is the distance from the center of a charged sphere, with $+Q$ units, to a point P , the force is given by

$$F = \frac{Q}{r^2}. \quad (205)$$

The element of work done in moving a unit charge a distance dr toward Q is

$$dW = Fdr = \frac{Qdr}{r^2}. \quad (206)$$

The total work done in moving the unit charge from without the field to the point P is then

$$W = \int Fdr = Q \int_{\infty}^r \frac{dr}{r^2} = \frac{Q}{r} = V_r, \quad (207)$$

the potential at P .

When other charges are in the field, the potential at a point may be found by adding potentials at the point due to each charge, giving due regard to the signs.

The method indicated above is easily applied where the attracting or repelling region may be considered as *concentrated* in certain points, as in the case of charges in static electricity uniformly distributed on spheres and of poles in magnetism, which may be looked upon as points in certain *extreme* cases. When, as is usually the case, the charge or pole is distributed, the determination of the potential becomes a problem in integration and often of considerable difficulty.

Nearly all experiments on static electricity are more successful in cold weather than in warm. This difference is probably due to a difference in humidity. In moist air, bodies are rapidly discharged, and it is relatively much more difficult to accumulate charges upon their surfaces. In cold weather the absolute humidity is usually much less than in warm weather. In an artificially heated room, the absolute humidity remaining the same as the outside air, the relative humidity is very much lessened on account of the higher temperature.

From the definition of a line of force, a positively charged body (an insulated pith-ball, for example) tends to move along the lines of force from positively charged bodies towards negatively charged bodies. If the ball were negatively electrified, it would tend to move in the opposite direction. This offers a means of testing the direction of lines of force, and consequently the character of the charge on a charged body.

If an insulated pith-ball be positively electrified (by being brought in contact with a glass rod which has been previously rubbed with silk), and then be suspended in a region supposed to be a field of electrical force, surrounding a charged conductor, one of three things will occur :

(1) The pith-ball will tend to move *from* the body supposed to be charged. This proves that the region is an electrical field with lines of force *issuing from* the body, which is therefore positively charged.

(2) The pith-ball will not tend to move at all. In this case we infer that the electrical field is too weak, or that the

charge on the pith-ball is too weak to produce a perceptible effect.

(3) The pith-ball will tend to move *towards* the charged body. This indicates that the region is a field of force with lines of force *entering* the body, which is therefore negatively electrified. We say "indicates," for it only proves that there is *now* a field between the pith-ball and the body, and that *one* of them was originally electrified before they were brought near together. We know that if the pith-ball were originally neutral, it would move toward a strongly charged body when brought near it. If the conductor were strongly charged, and the pith-ball weakly charged, both with positive electricity, the motion would be the same. Moreover, if the conductor were neutral, a charged pith ball brought near it would tend to move towards it.

These facts may be readily explained on the theory of induction. What is to be learned from this is that an electrical field of force, and the character of the charge on a body, cannot be certainly determined from the motion of a charged pith-ball *towards* the body. Under these circumstances, the pith-ball should be charged negatively (by being brought in contact with vulcanite previously rubbed with fur), and again experimented upon.

Sometimes it is better to first bring the pith-ball into contact with the body supposed to be charged, and then to test the nature of the charge on the pith-ball by bringing it near electrified glass and vulcanite rods in turn.

The electrification of a body may often be tested more reliably by the use of a proof-plane and a gold-leaf electroscope. In using the electroscope, it must be remembered that it is the *first* motion of the leaves, as the charged proof-plane is brought near it, that is to be noted. If the proof-plane has a considerable charge, whose sign is opposite to that of the leaves, it will cause them to collapse, and afterwards to diverge, as it is brought quite near to the electroscope.

EXPERIMENT P₁. Electrostatic induction.

I.

Every insulated conductor in the neighborhood of a positively charged body has induced upon its surface equal quantities of positive and negative electricity. The positive electricity is on the side farthest from the charged body, and the negative on the side nearest.

The object of this experiment is to investigate this and other phenomena of electrostatic induction.

For this experiment, a rather large insulated conductor is required. A Leyden jar, in which the small knob is replaced by a sphere 10 or 12 cm. in diameter, and connected with the inner coating, is excellent for this purpose on account of its great capacity. Such a conductor will usually retain its charge for the whole time of the experiment. A second insulated conductor, preferably an elongated cylinder with hemispherical ends, is also required.

Charge the sphere connected to the Leyden jar by means of an electrical machine. Place the second conductor in the electrical field produced by the charged conductor. The two conductors should be not more than 2 or 3 cm. apart.

The nature of the charge on different parts of the second conductor should now be investigated. This may be done, either by means of a pith-ball suspended by a silk fiber, or by means of a proof-plane and gold-leaf electroscope. Some idea may be formed of the direction of the lines of force in the electrical field surrounding the conductors by the direction in which a positively charged pith-ball tends to move.

After testing as above, remove the conductor, still insulated, to a distance from the charged body, and test again. Place the conductor again in proximity to the charged body, ground the conductor, and test with the pith-ball as before. Then move the conductor closer to the charged body, the connection with the ground having been first broken, and note any change in its

condition. Finally, remove the conductor to a distance from the inducing body and test again.

Throughout the experiment care must be taken not to allow any discharge from the charged body to the second conductor.

To secure uniform results it will generally be necessary to repeat these tests several times. This experiment will give satisfactory results only when the air is rather dry. It succeeds best in cold weather, when the room is artificially heated.

Addenda to the report :

(1) Define the following: unit electrical charge; electrical field of force; field of unit intensity; electrical difference of potential; unit difference of potential; electrical potential at a point; equipotential surfaces; electrical line of force; unit line of force, or unit tube of force; electrical capacity; unit of capacity.

(2) Give a demonstration of the fact that lines of force and equipotential surfaces are mutually perpendicular.

(3) State the general relation which the quantity of induced electricity on the conductor bears to the quantity on the charged body and the distance between them.

(4) Assuming that the charge of the charged body is positive, what is the *potential* of the conductor in each of the five cases investigated? What would be its potential if the charged body were negative?

(5) Draw two vertical sections of the two conductors showing equipotential surfaces and lines of force, one when the conductor having the induced charge is insulated, and one when it is grounded.

II.

Faraday's ice pail.

The object of this experiment is to show that when one kind of electricity is induced, an equal amount of the opposite kind is also induced.

Support a metal cylinder on an insulating stand, and connect

it by means of a fine wire to a gold-leaf electroscope. The top of the cylinder should be closed except for a circular opening large enough to admit a proof-plane or a small metal sphere with an insulating handle, without danger of touching.

I. Obtain a charge on the proof-plane or carrier sphere from an electrical machine and note carefully the action of the electroscope during the following operations :

(1) Bring the charged body near the cylinder.

(2) Hold it well within the cylinder but not making contact. Move the charged sphere about within the cylinder, taking care not to make contact.

(3) Finally touch the cylinder with the charged sphere.

II. Ground the cylinder and electroscope temporarily so that they are in a neutral state. (In cold, very dry weather touching with the hand may not be sufficient to ground the apparatus. Always make connection with a wire to a gas pipe.) Also discharge the case of the electroscope in the same way. Obtain another charge on the insulated carrier sphere and proceed as follows, noting the indications of the electroscope :

(1) Introduce the charged sphere within the cylinder, taking care not to make contact, as before.

(2) Ground the cylinder or electroscope.

(3) Break the grounding circuit and make contact between the carrier sphere and the insulated cylinder.

Make careful notes of each step in both sets of observations outlined above, repeating several times, and illustrate the distribution of charges and lines of force by diagram.

EXPERIMENT P₂. The principle of the condenser.

When a conductor connected to the earth is brought near a charged body, the potential of the charged body is reduced. If the conductor almost surrounds the charged body, and is very close to it, its potential will be very greatly reduced, although the amount of the charge remains absolutely unchanged.

Another way of viewing this fact is to consider that the

conductor lessens the quantity of free electricity on the charged body. The remainder of the charge is bound by the electricity induced on the near-by conductor. If, instead of maintaining the charge constant, the potential of the charged body is maintained constant, it will be found that the charge must be rapidly increased as the conductor connected with the earth is brought very near.

A combination of two conductors, very close together, one of which is connected to the earth, is called a condenser. The capacity of such a condenser is enormously greater than the capacity of either of the conductors of which it is composed when measured in the absence of the other.

In order to become familiar with the phenomena of the condenser, two forms are to be experimented with :

I.

The first form is an apparatus consisting of two vertical, parallel metal plates. These plates are both insulated, and are capable of motion along a line joining their centers.

(1) Fasten a pith-ball by means of a conducting thread to one plate, so that the ball rests against the plate.

(2) Connect the second plate to the earth, and charge the first one by means of an electrical machine.

(3) Move the plates to and from each other, and note the effect on the pith-ball.

(4) When the plates are quite near together, insulate the plate that was formerly grounded, and afterwards discharge the other plate by grounding it. Then separate the plates, and note the effect on the pith-ball.

(5) Fasten a pith-ball, as above, to the second plate also. Charge the plates while 1 or 2 cm. apart by connecting them to the opposite terminals of an electrical machine. Insulate the two plates without grounding either of them, and determine the character of the charge on each plate, by bringing a charged body whose condition is known near each pith-ball in turn.

(6) Connect one of the plates to the ground for an instant, and observe the effect on the sign and magnitude of the charges. Do the same with the second plate. Continue grounding alternately the two plates until they are both very nearly discharged.

(7) Charge the plates again, and observe the effect of connecting them by means of a good conductor. Repeat these observations with a glass plate between the metal conductors, the latter being very close, or in contact with the glass.

II.

The other form of condenser to be experimented with is a Leyden jar.

(1) Place the jar on an insulating support, and charge it by connecting the two coatings to the opposite terminals of an electrical machine.

(2) Disconnect from the electrical machine without grounding either coating, and experiment as with the plate condenser.

(3) Determine the number of alternate groundings of the two coatings necessary to reduce the charge to a definite fraction of its original value. For the purpose of this determination, the assumption may be made that the charge is proportional to the length of spark, when either coating is grounded, the other coating having been previously grounded and then insulated.

(4) When the jar is fully charged, make metallic connection between the two coatings. After a few minutes connect the coatings again, and note the existence of the "residual charge."

(5) Try to charge the jar by connecting only one coating to the electrical machine, the other coating being insulated. Investigate the nature of charges on the two coatings, and afterwards discharge the jar, observing whether the spark is comparable with that obtained when the jar was charged by the method first given.

The above-described experiments should be repeated several times in order to be certain of the results and to become familiar with the phenomena.

Addenda to the report :

(1) Indicate whether in the case of a condenser with a gas or a liquid as dielectric there would be anything comparable to the residual charge of a Leyden jar.

(2) Indicate why it requires a very large number of alternate groundings of the two coatings of a condenser to perceptibly reduce its charge.

(3) Assume that the alternate groundings of the two coatings are at equal intervals of time, and draw two curves with times as abscissas and potentials of the two coatings as ordinates.

(4) Draw two vertical sections of the jar, with coatings quite wide apart and showing lines of force and the vertical sections of equipotential surfaces, one in which the potential of one coating is zero, and one in which the surface of zero potential lies between the coatings.

(5) Determine approximately the electrostatic capacity of the jar from its dimensions.

(6) Assume the difference of potential between the coatings to be 100 electrostatic units, and compute the electrostatic force in the glass between the coatings.

(7) Compute the total charge in the jar under the above conditions.

(8) Compute the energy of the charge.

EXPERIMENT P₃. The Holtz machine.

In all influence machines, mechanical energy is directly transformed into the energy of electrification. The object of this experiment is to familiarize the student with the use of such machines and the principles involved in their action. Any type of influence machine may be used. The following is the procedure :

(1) Run the machine a few seconds until it is fully charged. The poles should be a few centimeters apart. Then stop the machine, and determine, by means of a pith-ball, the character

of the charge on every part of the machine. Repeat these observations several times, and observe whether the polarity of the machine becomes reversed.

(2) While the machine is charged and at rest, gradually bring the terminals together until a discharge takes place, and observe the effect upon the pith-ball. Determine the character of the charges on different parts of the machine when it is running steadily with the terminals too far apart to allow a discharge.

(3) Observe the difference in the discharge when the Leyden jars are removed; also when they are replaced by larger ones.

(4) Determine the maximum distance between the terminals at which a discharge will pass when the machine is running steadily but not very rapidly. Remove the crossbar and determine the maximum length of spark between the terminals when the machine is running at the same rate as before.

(5) Reverse the direction of rotation, and determine under what conditions the machine will work.

(6) Take the machine into a dark room, and run it steadily (a) with the crossbar in position, and the terminals in contact; (b) with the crossbar in position, and the terminals very wide apart; (c) without the crossbar, and with the terminals first in contact, and afterwards widely separated. Observe carefully the brush discharge between the revolving plate and the combs in all these cases.

Addenda to the report:

(1) Indicate the results, by positive and negative signs, upon carefully drawn diagrams of the machine.

(2) Explain how the machine becomes highly charged when one armature is given a small initial charge, and the plate is steadily revolved.

(3) Indicate the function of the crossbar, and the most advantageous position for it.

(4) Indicate the function of the Leyden jars.

EXPERIMENT P₄. **The Holtz machine** (*continued*).

After performing Exp. P₃, the following further experiments with an electrical machine will be found very instructive :

I.

Remove the Leyden jars, and connect to each terminal of the machine one coating of a condenser whose capacity may be varied in a known manner. Connect together the remaining coatings of the two condensers. Condensers formed by coating the whole of one side of a glass plate with tin-foil, while on the other side are several pieces of tin-foil insulated from each other, and of equal area, serve very well for this purpose.

Place the terminals at a fixed distance apart of 2 or 3 cm., and run the machine *uniformly*, counting the number of discharges per minute. Vary the capacity of the condensers connected to the terminals, and repeat these observations.

If the machine works uniformly, it will be found that the number of sparks per minute varies inversely as the capacity of the condensers. This fact may be readily shown to follow from the assumption that the amount of electrical work done when the machine is running uniformly is directly proportional to the time, and independent of the capacity of the condenser used.

On account of the uncertainty of the conditions, it will be necessary to take a large number of observations, and to use their mean in testing the truth of the above statement.

II.

Replace the Leyden jars by large ones. Separate the terminals to a distance of 8 or 10 cm., and run the machine until the jars are charged. Then slip off the belt, and stop the revolving plate with the finger. Under favorable circumstances, the plate will start to rotate backwards, and continue to do so for quite a number of turns. After a successful trial, it will be found that

the jars are very nearly discharged when the plate ceases to rotate.

Addenda to the report :

(1) If the electrostatic capacity of the condenser used is known, as well as the electrostatic difference of potential producing the sparks of known length, calculate the electrical work done in ergs per second and in watts.

(2) Prove upon theoretical grounds that the number of sparks per minute is inversely proportional to the capacity of the condenser used.

(3) Indicate the cause of the backward rotation in the second experiment above.

CHAPTER VIII.

GROUP Q: MAGNETISM.

(Q) *General statements ; (Q₁) Lines of force and the study of the magnetic field ; (Q₂) Determination of the magnetic moment of a bar magnet by the method of oscillations ; (Q₃) Determination of magnetic moment by the magnetometer ; (Q₄) Measurement of the intensity of a magnetic field ; (Q₅) Distribution of free magnetism in a permanent magnet.*

(Q) **General statements concerning magnetism.**

The phenomena of current electricity and of magnetism are almost, if not quite, inseparably connected. In the medium surrounding a conductor conveying a current of electricity, magnets are acted upon by a force. Such a region is naturally called a magnetic field of force.

Imaginary lines showing at all points the direction in which the force acts are called *lines of force*. Greater intensity of a field of force is usually represented by a greater number of these lines intersecting a given area. If masses of iron are brought into such a magnetic field of force, the intensity of the field is greatly increased, in the neighborhood of those parts of the iron where the lines enter and emerge. The same is also true of some other substances. This fact may be explained by saying that these substances are much better conductors of lines of force than the air or ether, or that their "permeability" for lines of force is greater than the permeability of the air. Such good conductors of magnetic lines of force are called magnetic substances.

Those portions of the magnetic lines which lie within a magnetic substance are called *lines of magnetization*. A mag-

netic substance containing these lines is said to be magnetized, and is called a magnet. Some magnetic substances, steel, for example, may be removed from the magnetic field where they have been magnetized, without losing their magnetic properties. The magnetic field surrounding the magnet moves with the magnet, and seems to have a fixed connection with it, independent of any other magnetic field. Such a body is called a permanent magnet.

That there is a magnetic field surrounding the earth is shown by the fact that in all localities where the experiment has been performed, a magnet is acted on by a torque tending to bring a certain line of the magnet called the magnetic axis into a particular position.

A magnet suspended freely in a magnetic field always comes to rest with its magnetic axis tangent to the lines of force. The positive direction of a line is the direction in which the end of the magnet points, which points north in the earth's field. The end of a magnet which points north in the earth's field is called the positive end, the other end being called negative.

If such a suspended magnet be brought into a field about the negative end of another magnet, it will set itself with its positive end pointing towards the negative end of the other magnet. The reverse is true in the field about the positive end of the second magnet. It follows from this that the lines of force of the field due to a magnet diverge from its positive end, and converge towards its negative end. Such a region within a magnet, towards which the lines of force converge, or from which they diverge, is called a pole.

A convenient statement of the fact that a magnet always tends to point in a particular direction in a magnetic field may be based upon the principle just laid down, viz. :

The positive pole of a magnet always tends to move along magnetic lines of force in the positive direction, and the negative pole in the negative direction. The mutual action of two magnets when brought near together may also be stated in the fol-

lowing form: *Like poles repel each other, and unlike poles attract each other.*

In a real magnet, lines of force diverge from a *region* in the positive half, curve around through space, and converge to a *region* in the negative half, and then pass on through the magnet as lines of magnetization. The idea of a pole, as a *point* towards which lines of force converge, is a highly idealized conception. It is a very useful conception, however, and by most authors is made the basis of the whole system of electromagnetic units. This ideal conception of a magnet pole is not likely to lead to error except in one case, namely, when the intensity of the force at a point in a magnetic field is expressed as a function of the strength of its poles, and the distance between them, as in Exp. Q₃.

An ideal magnet with ideal poles of a given strength and a given distance between them may be conceived, such that the magnetic field would be at four symmetrical points, exactly like the field produced by a real magnet. But the field of the real magnet would be different at all other points from the field of the ideal magnet. For example, the field of a magnet, quite close to its middle point, is such as would be produced by an ideal magnet with poles comparatively close together, while the reverse is true for a point near either end of the magnet. The error introduced into Exp. Q₃ by the assumption made is quite small whenever $D > 3l$.

Notwithstanding what has been said about magnet poles, the term "magnetic moment" has a perfectly definite physical meaning. If a magnet be placed in a magnetic field with its axis at right angles to the lines of force, it will be acted upon by a turning force. If the moment of this turning force be represented by L , and the intensity of the field by H , the magnetic moment of the magnet may be defined by the relation

$$MH = L, \quad (208)$$

in which M is the magnetic moment.

EXPERIMENT Q₁. Lines of force and the study of magnetic fields.

Surrounding every magnet and every current of electricity there is a magnetic field. The earth also has a magnetic field surrounding it. The object of this experiment is to investigate the direction in which the force acts in such fields; that is to say, the direction of the lines of force.

For this purpose place a sheet of glass immediately above the magnet whose field is to be investigated, and scatter over it iron filings, allowing them to drop from a height of 8 or 10 inches. If the magnet is sufficiently strong, the filings will arrange themselves in "lines of force." A slight tapping or jarring of the glass will probably make the magnetic curves more perfect. Sheet metal (not iron) or paper may be used instead of glass if desired, but the glass plate has the advantage of allowing the position of the magnet to be clearly seen. Permanent records of the curves may be obtained by allowing the filings to arrange themselves upon a sheet of blueprint paper, and exposing the latter to the sun while the filings are still in position.

Among cases which may be studied to advantage in this manner are the following:

- (1) The field of a single "horseshoe" magnet.
- (2) Two magnets with like poles near each other.
- (3) Two magnets with unlike poles near each other.
- (4) A bar magnet placed in the neighborhood of a horseshoe magnet.
- (5) The field of two horseshoe magnets placed vertically, their four poles forming a square.

Many other more complicated arrangements will suggest themselves. Observe also the effect of pieces of soft iron, placed in different positions in the field, upon the form of the curves obtained. If the piece of soft iron seems to produce little effect, bring it in contact with one pole.

The direction of the magnetic force at any point will be indicated by the direction in which a small compass needle

will set itself when placed at that point. By shifting the compass from place to place, the direction of the force can thus be found at any number of points.

To study the field by this method, place one or more magnets in the middle of a large board ruled in squares, which has been previously set with two opposite edges parallel to the magnetic meridian. The board should be so large that at the edges the field due to the magnets is decidedly weaker than the earth's field.

By means of a small compass determine the direction of the lines of force for a large number of points. There should be enough of these observations, so that the direction in which the compass needle would point if placed anywhere on the board may be known within rather narrow limits.

Make a diagram (to scale) of the board and magnets, and at each point where the compass was placed draw a little arrow to show the direction of the force. An arrow should also be drawn somewhere on the board to show the direction of the earth's field. Map the whole field on the board by means of lines representing the lines of force. These lines do not need to pass through the arrows, but should be so drawn as to represent the direction in which the compass needle would point if placed upon corresponding points on the board.

The field so mapped is the resultant field of the magnets and of the horizontal component of the earth's field. Therefore, it must not be expected that all the lines of force will enter a magnet.

In the neighborhood of every magnet or system of magnets there are in general two or more points where the magnetic field due to them exactly neutralizes the earth's field. At these points there will be no directive force acting on the compass needle, and on opposite sides of these points the needle will point in opposite directions. Locate these points on your diagram.

Addenda to the report:

- (1) State the law of magnetic force.
- (2) Define: unit magnet pole; magnetic field of force; field of unit intensity; magnetic difference of potential; magnetic potential at a point; equipotential surfaces; magnetic lines of force; unit line of force, or unit tube of force.
- (3) Show that lines of force and equipotential surfaces are mutually perpendicular.
- (4) Indicate the reason why, in this experiment, the filings move away from points directly above the magnet, especially in the neighborhood of the poles.
- (5) Draw the horizontal sections of several equipotential surfaces whose potentials differ by equal amounts.
- (6) Assume that the potential of any point a centimeter from the north pole is 100, and that the surface of zero potential bisects the distance between the poles, and determine approximately from the map and from the assumptions already made the magnetic force at several points 10 or 20 cm. distant from the magnet.

EXPERIMENT Q₂. Determination of the magnetic moment of a bar magnet by the method of oscillations.

A magnet suspended by a torsionless fiber with its axis horizontal will come to rest with its magnetic axis in the magnetic meridian. If the magnet is turned so as to make a *small* angle with the magnetic meridian, the moment of the force tending to restore the magnet to its position of equilibrium is directly proportional to the angular displacement. The resulting motion of the magnet, when left free to vibrate, is therefore a simple harmonic motion.

The periodic time is dependent upon the magnetic moment of the magnet, its moment of inertia, and the horizontal intensity of the magnetic field in which it is suspended. The following equation may be derived by equating the kinetic energy of the magnet at its mid-position to the potential energy when at the

end of its swing. The method of derivation is the same as that pursued in Exp. E₁.

$$MH = \frac{4\pi^2 K}{T^2}. \quad (209)$$

To perform the experiment :

(1) Place the magnet in a small wire stirrup, and suspend it by a few untwisted silk fibers. It should be suspended in a box with glass ends, to avoid the effect of air currents, and a position should be chosen at a distance from movable masses of iron. If the bar is rather strongly magnetized, the torsion of the silk fiber may be neglected, or, if desired, it may be eliminated by determining the ratio of the moment of torsion to the moment of the magnetic forces.*

(2) Set the magnet to vibrating through an arc of not more than five degrees. Determine the period of oscillation by the method of Exp. A₅ II, making two independent sets of observations at each of two assigned stations.

(3) Measure the length, diameter, and mass of the bar, and from these data compute its moment of inertia. If the value of the horizontal component of magnetism for the place where the magnet was suspended is known, the value of M may be computed from the above equation.

The method of oscillations may be used, if desired, to determine the value of H in different parts of the laboratory; in which case the period of oscillation must once be determined from observations taken in a locality where H is known.

The data obtained by performing both Q₂ and Q₃ is sufficient for the computation of M and H in absolute measure. Two conditions, however, are assumed and must be complied with.

I.

The magnetic moment of the magnet used in both experiments must be the same. To comply with this condition the *same* magnet must be used for both experiments, and the mag-

* Kohlrausch, Physical Measurements, p. 128.

netic moment must not have suffered any change between the times of performing the two experiments.

II.

The horizontal intensity of the field where the magnet oscillated in Exp. Q_2 is the same as the field where the magnetic *needle* was placed in Exp. Q_3 . This condition may be complied with by performing the two experiments at the same place, and at a distance from all *movable* magnets or magnetic substances.

Addenda to the report :

(1) State the effect upon the period of oscillation, if in the above experiment the magnet were not quite horizontal.

(2) State the effect upon the period, if the magnet were bent into the form of a horseshoe, without changing its intensity of magnetization.

(3) Determine the average intensity of magnetization in the magnet experimented with, and indicate in what part of the magnet it is the greatest, and in what part the least.

(4) Compute the ergs of work that would be required to rotate the magnet 180° about a vertical axis in the earth's field from the position of rest.

(5) Assuming the dip 75° , compute the work required to rotate the magnet from a vertical position through 180° about a horizontal axis.

EXPERIMENT Q_3 . Determination of magnetic moment by the magnetometer.

When two forces act at right angles to each other, their resultant makes an angle with each of the forces such that the tangent is the ratio of the two forces. See Fig. 71, in which a and b are the forces and α and β the angles which their resultant r makes with them, respectively.

Obviously, $\tan \alpha = \frac{b}{a}$ and $\tan \beta = \frac{a}{b}$.

This fact may be used to determine the ratio of the intensity of two magnetic fields at any given point.

When a magnet is so placed that the field due to it at a given point is at right angles to the field due to the earth, a short magnetic needle placed at that point will be deflected from the magnetic meridian through an angle whose tangent is equal to the ratio between the intensities of the two components of the field at that point.

The needle must be *short* with respect to the distance to the magnet, for otherwise its ends would extend too far beyond the point at which the field of the magnet has the intensity given below.

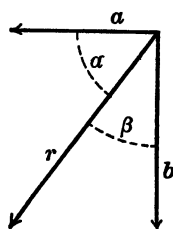

Fig. 71.

The strength of the field at any point due to a magnet is a known function of its magnetic moment, the distance between its poles, and the distance of the point from the magnet.

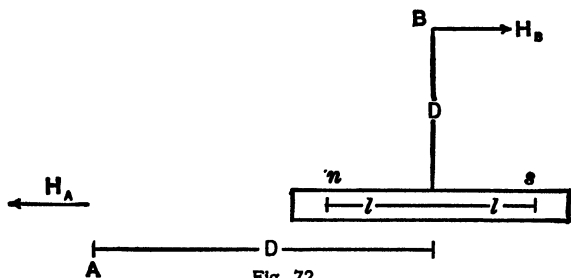

Fig. 72.

For example, the strength of the field at *A*, due to a magnet whose poles are at *n* and *s* (Fig. 72), is

$$H_A = \frac{2MD}{(D^2 - l^2)^2}. \quad (210)$$

At *B*, the strength of the field due to the same magnet is

$$H_B = \frac{M}{(D^2 + l^2)^{\frac{3}{2}}}, \quad (211)$$

in which *M* is the magnetic moment of the magnet, *2l* the distance between its poles, and *D* the distance of *A* or *B* from the center of the magnet.

If the magnet is at right angles to the magnetic meridian, a magnetic needle placed at A will be deflected from the meridian through an angle δ according to the relation

$$\frac{M}{H} = \frac{(D^2 - l^2)^2}{2D} \tan \delta, \quad (212)$$

and there will be a corresponding relation for the position B .

These equations may also be derived by an application of the principle of moments to the magnetic forces acting on the suspended needle.

The magnetometer consists, essentially, of a suspended magnetic needle, a bar, 1 m. or more long, upon which to place the magnet with which the experiment is to be performed, and some means of measuring the angle through which the needle is turned.

In preparation for this experiment, adjust the magnetometer bar at right angles to the magnetic meridian. This may be done with sufficient accuracy with the aid of a small compass needle. If greater accuracy is desired, adjust the magnetometer bar by trial so that the same deflection is produced when the magnet is placed on opposite sides of the magnetometer needle, at the same distance from it, and with the *same pole pointing towards it*.

Having completed the adjustment, proceed as follows:

(1) Place the magnet on the bar with its poles pointing east and west, and at a distance of not less than 20 or 30 cm. east of the magnetometer needle.

(2) Observe the magnetometer reading by means of a telescope and scale, and the mirror on the magnetic needle. Then turn the magnet end for end, keeping its distance from the needle the same, and again observe the reading. Half the difference of the two readings is a measure of the deflection of the needle from its position of rest on account of the presence of the magnet.

(3) Reverse the magnet in this way several times so as to get the average of a number of observations.

(4) Finally place the magnet at the same distance to the west of the magnetometer needle and proceed as before. From the average of all the deflections observed, and the distance between the mirror and scale, compute the angle through which the needle is deflected.

As a check the observations should be repeated with the magnet at such a distance from the needle as to produce a deflection which is considerably greater or less than that first used.

The following table gives typical data and shows the method of presenting them:

MAGNETIC MOMENT BY THE MAGNETOMETER.

| North Pole Pointing | Distance of Center of Mag. from Needle. | Scale Reading. | Deflection in Scale Div. | Distance between poles of magnet, $2l = 22$ cm. |
|---------------------|---|----------------|--------------------------|---|
| | | 48.37 | | Horizontal intensity = 0.145 |
| West | 54 W. | 3.04 | 45.33 | Average deflection = 45.91 |
| East | 54 W. | 94.62 | 46.25 | Distance from mirror to scale = 91.1 scale division |
| East | 54 E. | 95.63 | 47.37 | $\tan 2\delta = 0.5037$ |
| West | 54 E. | 3.57 | 44.69 | $2\delta = 26^\circ 44'$ |
| | | 48.26 | | $\tan \delta = 0.2376$ |
| West | 80 W. | 35.86 | 12.40 | Magnetic moment = 2436 |
| East | 80 W. | 60.68 | 12.42 | Average deflection = 12.43 |
| East | 80 E. | 60.85 | 12.59 | $\tan 2\delta' = 0.1364$ |
| West | 80 E. | 35.95 | 12.31 | $2\delta' = 7^\circ 46'$ |
| | | 48.26 | | $\tan \delta' = 0.0679$ |
| | | | | Magnetic moment = 2426 |

In the above formula, $2l$ is the distance between the poles of the magnet, and is therefore less than the length of the bar itself. The position of the poles, and therefore the length $2l$, may be approximately determined by the aid of a small compass.

If H is known, M may be computed; or, if the product MH is known, both M and H may be computed in absolute measure. This product may be obtained by the method described in Exp. Q₂.

If the magnetometer admits of it, a similar series of observations should be taken with the magnet placed at points north and south of the magnetometer needle, its poles pointing east and west as before.

Addenda to the report :

(1) Determine the strength of each pole of the magnet experimented with.

(2) Calculate the magnetic force and potential due to the magnet for two or three points in its neighborhood.

(3) Calculate the work required to carry a magnet pole of strength equal to either pole of the magnet, from one pole face to the other pole face, along any path.

(4) Compare the pull on either magnetic pole with the pull of gravity on one gram for a case in which the inclination of the earth's lines of force is 75° .

EXPERIMENT Q₄. Measurement of the intensity of a magnetic field.

The intensity of a magnetic field at different points may be compared with the intensity of the earth's field by either of the methods made use of in Exps. Q₂ and Q₃. In the following experiment, these methods are to be used in measuring the magnetic field at a series of points in the neighborhood of a permanent magnet.

I.

Place the magnet with its axis in the magnetic meridian, its negative pole pointing north. For all points to the east or west of the middle of the magnet, the intensity of the field will be the arithmetical sum of the earth's horizontal intensity and the intensity of the field at that point, due to the magnet. For all points to the north or south of the magnet, the intensity of the field will be the difference of these two quantities.

Determine the period of oscillation of a small magnet of any shape, for a series of points on a line at right angles to it, and bisecting the distance between its poles. Do the same for a

series of points north or south of the magnet. For each point, the number of oscillations produced in three or four minutes should be determined.

As the intensity of the field due to the magnet varies most rapidly near it, the points of observation should be closer together the nearer they are to the magnet. A good series of distances is the geometric series $\frac{1}{16}L$, $\frac{1}{8}L$, $\frac{1}{4}L$, \dots $2L$, in which L is the length of the magnet.

As in Exp. Q₂, we have

$$H_p \pm H = \frac{4\pi^2 K}{MT_p^2} = \frac{C}{T_p^2}, \quad (213)$$

in which H_p is the intensity of the field due to the magnet at the point where the time of vibration is T_p , H is the horizontal intensity of the earth's magnetism, and C is a constant depending upon the magnet. C may be eliminated by taking the time of vibration at a distance from the magnet where H_p is zero. H_p can then be computed in terms of H , or if H is known it may be computed in absolute measure.

Plot a curve with distances from the magnet as abscissas, and corresponding values of H_p as ordinates.

II.

Place a large bar magnet at right angles to the magnetic meridian, as in Exp. Q₃. For points "A" and "B" the ratio of the intensity of the field, due to the magnet and the earth's horizontal intensity, will be equal to the tangent of the angle through which a magnetic needle will be deflected from the magnetic meridian, if placed at that point.

Place a compass with a circle graduated to degrees at a series of points "A," at distances from the magnet as in I above. For each point determine the deflection from the meridian as follows: Read both ends of the needle, then reverse the magnet and read again. The angle through which the needle has been turned is double the angle of deflection from the meridian. In the same manner make a series of

observations for points "B." Plot a curve with distances from the magnet as abscissas, and the intensity of the field due to the magnet as ordinates.

Addenda to the report:

(1) From the equations in Exp. Q₈, and several points on one of the above curves, compute values of M . The points taken should not be observed points unless these points happen to fall exactly upon the curve.

(2) Note whether these values of M show a progressive increase or decrease, and if so, indicate cause of the variation.

EXPERIMENT Q₅. Distribution of "free" magnetism in a permanent magnet.

For purposes of calculation, the distribution of imaginary magnetic matter in a magnet may be considered in two ways: as a distribution throughout its volume, or over its surface. The volume distribution or intensity of magnetization is greatest midway between the poles. The surface distribution is greatest near the ends, and is vanishingly small midway between the poles. This imaginary magnetic matter is supposed to be so distributed as to produce by its attraction or repulsion the same field of force that the magnet produces. From this we see that the quantity of surface magnetism, or "free" magnetism, as it is called, is everywhere proportional to the number of unit lines of force which enter or emerge from the magnet.

I.

The distribution of magnetism may be determined by measuring the force necessary to detach a small, soft iron armature from the magnet. For measuring this force use a pair of balances or a spiral spring, whose extension can be readily determined.

Determine in this way the force necessary to detach the armature for ten or twenty points along the magnet from one end to the other. The magnet may not be symmetrically magnetized; if not, the forces at symmetrical points will not be

equal. Plot a curve with distances from the center of the magnet as abscissas, and the forces necessary to detach the armature as ordinates.

In considering that this curve represents the distribution of magnetism along the magnet, two things should be remembered:

(1) By induction, the distribution of magnetism is slightly changed on account of the presence of the armature. If the armature is quite small with respect to the magnet, this may be neglected.

(2) The force with which the soft iron armature is attracted to the magnet is proportional to the square of the magnetism at that point. This is true, since the force is proportional to the product of the magnetism of the magnet and the magnetism of the armature, in the immediate neighborhood of the point of contact, but the induced magnetism of the armature is itself proportional to the magnetism of the permanent magnet.

II.

The distribution of magnetism may also be determined by the method of oscillations.

Place a bar magnet in a vertical position, and determine the period of oscillation of a small magnet for a series of positions along the magnet, and quite close to it. These points should be north or south of the magnet.

As in Exp. Q₄, we have

$$H_P \pm H = \frac{C}{T_P^2}, \quad (214)$$

in which H_P is the intensity for the point P of the field due to the magnet, resolved in a direction perpendicular to its length.

If the point P is quite close to the magnet, H_P will be proportional to the free magnetism at the corresponding point of the magnet. As in (1), plot a curve with distances from the center of the magnet as abscissas and corresponding values of H_P as ordinates.

CHAPTER IX.

GROUP R: THE ELECTRIC CURRENT.

(R) *General statements*; (R₁) *The law of the galvanometer*; (R₂) *Measurement of current by electrolysis*; (R₃) *Theory of shunts*; (R₄) *Measurement of the constant of a sensitive galvanometer*; (R₅) *Measurement of current by means of the galvanometer*; (R₆) *Calibration of an ammeter.*

(R) **General statements concerning the electric current.**

The electric current may be defined as the rate at which electricity is transferred, or the amount of electricity which passes through a given plane cutting the circuit at right angles to the lines of flow, in a unit time. When two bodies which differ in potential are connected by means of a conductor, the fleeting phenomena which accompany the electric discharge occur, and we have a transient current; if the difference of potential be maintained constant by the expenditure of work, there will be a permanent current.

If current were always measured by electrolysis, the idea of current would be a derived conception involving *time*. Since, however, when a current flows in a conductor there is a magnetic field surrounding the conductor, the intensity of which at any given point is always directly proportional to the current, it is more convenient to measure the latter by means of the field which it produces. In this way we reach a conception of current which does not directly involve time.

Those instruments which measure currents by comparing the field produced with the earth's magnetic field, with the earth's field as modified by controlling or regulating magnets,

or with the field of a permanent magnet, are called galvanometers.

The lines of force surrounding a wire carrying a current may easily be mapped by the aid of iron filings. Figs. 73 and 74 are such maps showing the field around a straight wire. The former was obtained by cutting a sensitive plate and passing the conductor, the field of which was to be mapped, through the hole. The plate was then fastened in a position at right angles to the conductor. Current was sent through the

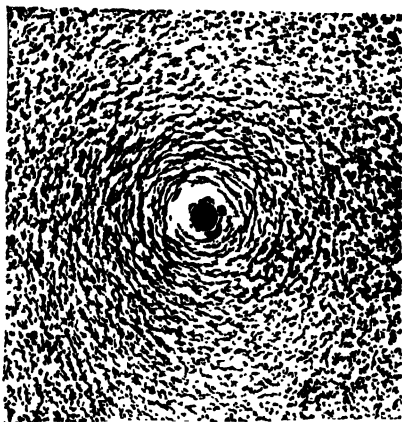

Fig. 73.—Map of the Field around a wire carrying Current (from a Photograph).

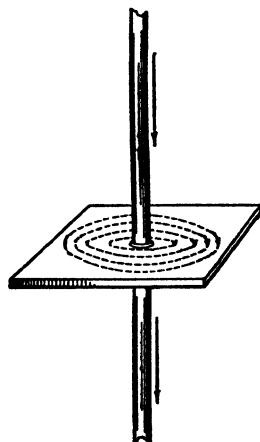

Fig. 74.

latter, and the surface of the film was strewn with iron filings. These operations having been completed by the red light of the developing room, the plate was then exposed for three seconds to gaslight, after which the photograph was developed, giving the map.

The direction of the lines of force, at any point in the field, produced by a current, is always at right angles to the plane containing the point and the current. The intensity of this field may be deduced from Laplace's law, of which the following equation is a statement :

$$dH_p = \frac{I \sin \theta ds}{r^2}. \quad (215)$$

In this expression, dH_P is the intensity of the magnetic field at the point P , due to the short element ds of the current of intensity I ; r is the distance from the point P to the element ds , and θ is the angle which the direction of the element ds makes with the line drawn from it to the point P .

The absolute unit of current in the electromagnetic system is *that current, a unit length of which will produce unit magnetic field at unit distance from the current*. It follows that the C. G. S. unit current in the electromagnetic system, flowing around a circle of 1 cm. radius, will produce at the center of the circle a field whose intensity is 2π units.

The Chamber of Delegates of the Electrical Congress at Chicago adopted "as a [practical] unit of current the international ampere, which is one tenth of the unit of current of the C. G. S. system of electromagnetic units, and which is represented sufficiently well for practical use by the unvarying current which, when passed through a solution of nitrate of silver, in water, and in accordance with the accompanying specifications, deposits silver at the rate of 0.001118 gram per second."

The Tangent galvanometer.

The intensity of the field at the center of the galvanometer coils produced by unit current flowing in the coils is called the *true* constant of the galvanometer, and is generally denoted by G . For many galvanometers, this constant may be computed from Laplace's law, and the dimensions, position, and number of turns of the coils.

If a galvanometer coil is placed with the plane of its windings in the magnetic meridian, the field produced by it at the center of the coil (or at any point on its axis) will be at right angles to the earth's field. Let CC' (Fig. 75) represent the horizontal section of the galvanometer coil. The intensity of the field at the point O , due to the current I flowing in the coils, is GI . If H represents the horizontal intensity of the field at the point O due to the earth (and regulating mag-

nets), the resultant of these two fields will make an angle δ with the plane of the coils such that

$$I = \frac{H}{G} \tan \delta. \quad (216)$$

If a *short* magnetic needle be suspended at the point O , it will come to rest with its magnetic axis in the plane of the resultant magnetic field through the point O . That is, it will turn through the angle δ from the position of equilibrium when no current flows. If the magnetic needle is not short, its ends are liable to extend too far beyond the *point* O at which the field due to the current I has the intensity GI . If the current is required in amperes instead of in absolute units of current, the above equation becomes

$$I = 10 \frac{H}{G} \tan \delta. \quad (217)$$

The constant quantity $10 \frac{H}{G}$ is called the "reduction factor," the "working constant," or, for brevity, simply the constant of the galvanometer. If this be represented by I_0 , we have

$$I = I_0 \tan \delta. \quad (218)$$

From (218) it is obvious that the galvanometer constant I_0 is that current which will produce a deflection of 45° .

In this discussion it is assumed that the friction of the needle on the pivot or the torsion of the suspending fiber is negligible. This is generally a safe assumption except in sensitive galvanometers, where a very small needle or an astatic system is used. In such cases, the moment of the force of torsion tending to bring the needle back to its position of equilibrium may be very considerable compared with the moment of the magnetic forces tending to return the needle to the magnetic meridian. Moreover, there may be a twist in

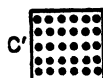
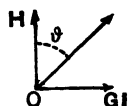

Fig. 75.

the fiber, such that the needle does not return to the magnetic meridian when the current ceases to flow in the galvanometer coils.

In Fig. 75, above, it is obvious that if the galvanometer current is reversed, the direction of the field GI will be reversed. In this case the magnetic needle will be turned through the same angle δ , with its north end pointing on the opposite side of the meridian. This offers a means of setting the galvanometer coils in the plane of the magnetic meridian, if they are not already so adjusted.

For this purpose, we send a current through the galvanometer, and observe the angle through which the needle has turned when it comes to rest. We then reverse the current through the galvanometer, and observe the corresponding angle of deflection on the opposite side of the position of equilibrium. If these angles are not equal, we turn the galvanometer coils in such a direction as to increase the smaller angle of deflection, and repeat until the difference of the two angles is a small fraction of either one of them. In doing this it must be remembered that if the scale is turned with the galvanometer coils, the needle will come to rest at a new position with respect to the scale; *i.e.* the galvanometer will have a new "zero point."

In measuring current by means of a galvanometer, angles of deflection should be determined for the current, both direct and reversed. There are two reasons for this:

(1) If the galvanometer coil makes a small angle with the magnetic meridian, it may be proved* that the mean of the deflections for direct and reversed current will be in error by a small quantity of the second order.

(2) The equilibrium position or zero point of a galvanometer needle is constantly varying, the fluctuations being due to variations in the earth's magnetic field. Now it is quite as

* See Mascart and Joubert, *Leçons sur l'électricité et le magnétisme*, vol. 2, p. 235; also Nichols, *The Galvanometer*, Lecture 2.

convenient to observe the reading for reversed current as it is to observe the zero reading for every measurement.

In measurements by this method of direct and reversed deflections a commutator, or reversing key, is used. A double-pole double-throw switch may be used for reversing the direction of the current in any part of the system desired by connecting the points *af* and *dc*. When the blades of the switch are closed, as shown in Fig. 76, the current flows from the battery along the path *afeghbc*. When the blades are thrown into the reverse position, the current flows along the path *abhged*, being in a reverse direction between the points *g* and *h*.

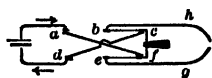

Fig. 76.

The angle of deflection of the galvanometer needle may be determined directly from the reading of a long pointer moving over a circular graduated scale. In this case both ends of the pointer should be read in order to eliminate eccentricity, as well as to get a more accurate value of the deflection.

In many cases the angle of deflection is determined by means of a small mirror permanently attached to the magnetic needle. With mirror galvanometers either a telescope and scale, or a lamp and scale, may be used. In either case, the

angle of deflection is computed in the same way.

Let *OM* (Fig. 77) be the horizontal section of the mirror attached to the galvanometer needle, *S* the scale, and *T* the telescope. The telescope and scale should be adjusted at right

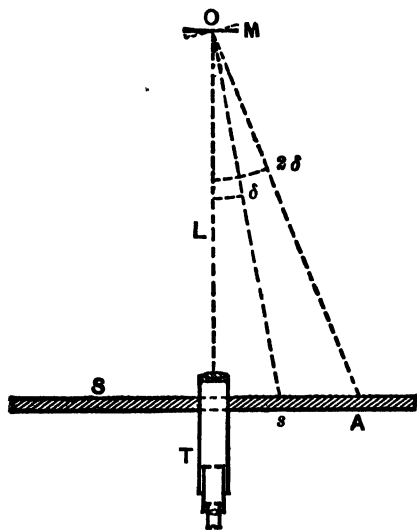

Fig. 77.

angles to each other, and so placed that the portion of the scale immediately below (or above) the telescope is seen reflected from the mirror through the telescope when no current flows through the galvanometer. If the galvanometer needle be now deflected through the angle δ , a new portion of the scale will be seen reflected from the mirror. From the law of reflection, the angle which the ray reflected from the mirror into the telescope makes with the normal must be equal to the angle which the incident ray AO makes with the same normal. It follows that the angle AOT between the reflected and incident rays is equal to 2δ . If s is the deflection along the scale from the scale reading when no current is flowing, and L the distance of the scale from the mirror, we have

$$\tan 2\delta = \frac{s}{L}. \quad (219)$$

From this equation and a table of tangents, δ , and hence $\tan \delta$, may be deduced. For simplicity of computations, the distance L from the scale to the mirror is often made equal to 50 scale divisions. In this case, the difference between the scale readings for the same current for the two positions of the reversing switch, direct and reversed, divided by 100 gives directly $\tan 2\delta$.

$$\tan 2\delta = \frac{2s}{2 \cdot 50} = \frac{\text{double deflection}}{100}. \quad (219')$$

It may be readily shown that when δ is quite small, $\tan \delta$ is very nearly proportional to s . Under this condition it follows that current is very nearly proportional to deflection, and we may use the equation

$$I = I_0' s, \quad (220)$$

in which I_0' is the constant per scale division. The error in using this approximate value for the current is as follows:

When $\frac{s}{L} = \frac{1}{10}$, the error is about 0.0025.

When $\frac{s}{L} = \frac{1}{4}$, the error is about 0.0100.

When the current is reversed in a galvanometer, it often takes several minutes for the needle to come to rest. Time may be saved after a reading has been made in one direction, by opening the switch and leaving it open until the needle in its free swing has nearly come to rest, then closing and opening the switch quickly several times in the reversed position, finally leaving it closed in that position. A little practice will make possible quite rapid readings.

There are two principal methods of "damping" the oscillations of galvanometer needles, and making the instrument nearly or quite "dead-beat."

(1) By the attachment of a mica or aluminum vane to the needle. This vane, by friction against the air in an inclosed place, brings the needle to rest much more quickly than would otherwise be the case. The action may be increased by suspending the vane in a vessel of oil.

(2) By suspending the magnetic needle within a cavity in a small mass of copper. As the magnet moves in this cavity, causing the lines of force to sweep through the copper, currents of electricity are induced. These currents, as stated in Lenz's law, are always in such a direction as to oppose the motion which produced them.

The best example of this is found in the type of instrument first designed by Siemens. In this form of galvanometer the magnetic needle is of the horseshoe type, ordinarily called a bell magnet. This magnet is suspended in a hole but little larger than itself in a copper sphere. Fig. 78 shows a vertical section of the copper sphere, with the inclosed magnet; Fig. 79 represents a cross section of the same magnet.

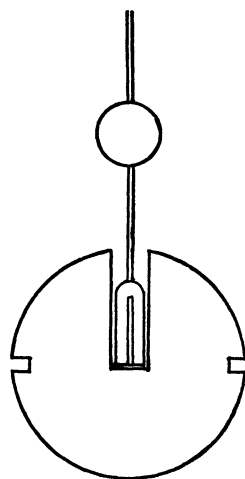
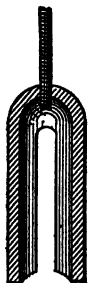

Fig. 78.

In the use of sensitive galvanometers, the question will often arise as to what type of galvanometer will be most sensi-

tive for a particular purpose. This question cannot be settled in general terms, on account of the great difference between the different types. The more restricted question as to what number of turns will be most sensitive for a particular purpose may be easily determined.



If the type of galvanometer, the size of the coils, the mass of copper in them, and the closeness of the turns to the needle remain the same, it may readily be proved that that instrument will be most sensitive whose *internal resistance is equal to the external resistance in series with it.*

The d'Arsonval galvanometer.



Fig. 79.

The d'Arsonval galvanometer is an instrument based on the fact that a wire carrying a current which is in a magnetic field has a force acting on it which is proportional to the length, l , of the wire in the field, the strength of the current, I , flowing in the wire, and to the strength of the field, f .

The following equation gives an expression for the force :

$$F = Ilf \sin \theta, \quad (221)$$

in which θ is the angle between the direction of the magnetic field and the wire carrying the current.

If a coil of wire, free to rotate about its axis, be suspended in a magnetic field, there will be a torque action tending to turn the coil about its axis when current flows in the coil.

The d'Arsonval galvanometer is based on the above outline. It consists of a coil of wire suspended by a phosphor bronze or steel ribbon above and a small wire coil below. The suspensions serve as conductors for the current into and out of the coil. The coil is suspended to rotate freely between the poles of a strong horseshoe magnet.

When a current flows in the coil, the magnetic torque causes the coil to turn about its axis. The coil will come to rest in

such a position that the return torque due to the suspensions is equal to the magnetic torque.

The expression for the magnetic torque is obtained as follows: The force acting on each vertical length of wire l is $Ilf \sin \theta$ and the corresponding torque is $Ilf \sin \theta \frac{a}{2} \cos \delta$. In the case here taken the field is supposed to be uniform and at right angles to the length of the elements l of the wire as shown in Fig. 80, which gives a vertical section (a) and a plan (b) in which the coil is displaced through an angle δ . Since $\theta = 90^\circ$, the total torque will be given by the expression

$$L = 2 n I l f \frac{a}{2} \cos \delta = I A f \cos \delta, \quad (222)$$

in which n is the total number of turns and A is the "equivalent area" of the coil, $A = nla$.

If the pole pieces be properly shaped and a soft iron core be placed within the open space of the coil, the magnetic field will be approximately radial and the plane of the coil will be in the plane of the field. Under these conditions the magnetic torque will be constant, δ will be zero, and therefore

$$L = I A f. \quad (223)$$

The mechanical torque tending to return the coil to its rest position for no current is approximately proportional to the angular deflection δ . An expression for the value of the mechanical torque may be written

$$L_m = L_0 \delta, \quad (224)$$

in which L_0 is the mechanical constant. (See F_2 .) When current is flowing in the coil a deflection will be produced and the coil will come to rest as noted above when

$$I A f = L_0 \delta. \quad (225)$$

Solving this equation for I ,

$$I = \frac{L_0}{A f} \delta = k' \delta; \quad (226)$$

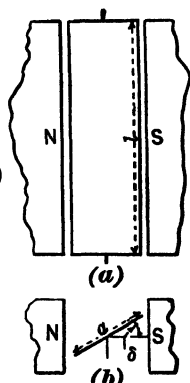

Fig. 80.

that is, the current is proportional to the angular deflection. This principle is used in the manufacture not only of the stationary form of d'Arsonval galvanometers, but also of portable types such as ammeters and voltmeters for direct current measurement.

If the field be uniform and of constant direction in the neighborhood of the suspended coil from equations 222 and 224 it may be shown that

$$I = \frac{L_0}{Af} \frac{\delta}{\cos \delta} = k' \tan \delta. \quad (227)$$

If I is expressed in amperes, the right-hand member must be multiplied by 10. If a telescope and scale be used to measure δ , the same reasoning may be applied as that given above in the case of the tangent galvanometer. For small deflections it may be found that currents flowing through the coil of the d'Arsonval galvanometer are very nearly proportional to the scale deflections. Indeed, the galvanometer may be so designed as to give very nearly a constant relation between the current to be measured and the deflection. In such a case the law for the galvanometer may be expressed as

$$I = ks, \quad (228)$$

in which k is the current constant in amperes per scale division of single deflection and s is the number of scale divisions of single deflection. In all cases the d'Arsonval galvanometer should be carefully calibrated over the range it is to be used.

For a given current the deflections from the "zero," or no current scale reading should be alike. Readings should be made both direct and reversed for each current value. Rapid reading is facilitated by the operations noted above in the use of the tangent galvanometer.

EXPERIMENT R₁. Law of the galvanometer.

The introduction to the R group should be carefully read before performing either of the following experiments.

I.

Tangent galvanometer.

If a galvanometer coil is placed with the plane of its windings in the magnetic meridian, the magnetic field due to a current circulating in the coils will be (in the axis of the coil) at right angles to the earth's magnetic field. The resultant of these two fields will therefore make an angle with the magnetic meridian whose tangent is the ratio of the intensity of the earth's field to the field due to the current in the galvanometer coils. A *short* magnetic needle suspended anywhere in the axis of the coil will set itself along this resultant direction. If the needle is not a short one, it will, when considerably deflected from the meridian, extend beyond the axis to points where the two components of the field are not at right angles to each other. Therefore the tangent law will no longer hold.

This experiment is intended to give a method of testing experimentally whether a given galvanometer obeys the law of tangents (*i.e.* whether the tangent of the angle of deflection is proportional to the current).

Use a galvanometer in which the angles are to be observed directly. Connect the galvanometer in series with a resistance box and cell, and place a reversing key somewhere in the circuit so that the direction of the current in the galvanometer can be readily reversed. Set the plane of the coil to be used in the magnetic meridian by the method indicated in the introduction to this group. It is usually not sufficient to bring the pointer to the zero of the circular scale. In general the scales will be found to be so mounted as to make this impossible. The "zero" readings will consequently be the readings of the ends of the pointer when no current is flowing. In making readings always read both ends of the pointer for both directions of current through the coil. Designate the two ends of the pointer so that there may be no confusion in interpreting the readings of its two ends for direct and reverse readings. They are designated as *N* and

S in the sample of data given below, but that may not be satisfactory with the galvanometer assigned.

Two sets of readings are to be made, using coils of different number of turns as directed. Enough gravity cells should be used to give a deflection of about 70° when using the coil of the larger number of turns, with no resistance in the resistance box. Make readings for current in both directions, "direct and reverse," for each of at least ten different box resistances from 0 to 40 ohms at approximately equal steps.

Using the data thus obtained, plot two curves, one for each coil used, on the same sheet to the same scale with cotangents as ordinates, and box resistances as abscissas. If the galvanometer obeys the tangent law, each curve obtained by plotting as above should be a straight line. Draw a straight line, therefore, that passes as nearly as possible through all the points, and produce this line backward until it intersects the horizontal axis. The distance between the origin and this point of intersection is a measure of the resistance in the circuit outside the resistance box; *i.e.* if we call this resistance R_0 , then $R_0 =$ galvanometer resistance + battery resistance + resistance of connecting wires. The slope of line is $\frac{I_0}{E}$.

Now, if E is the E. M. F. of the cell, and R the resistance in the box, then

$$I = I_0 \tan \delta = \frac{E}{R_0 + R}. \quad (229)$$

If E is known, and R_0 determined from the curve, as stated above, the constant of the galvanometer can be computed. In making this computation, take the E. M. F. of a gravity cell as 1 volt. In making computations it will be found advantageous to use the tables in the back of the Manual. The values of both these unknown quantities are to be obtained from the curves as well as from the data.

In your report, derive the law of the tangent galvanometer. Discuss the effect on the galvanometer constant of the torsion

of the fiber, the length and magnetic moment of the needle. From Ohm's law, derive the equation of the curve and show that the intercept and the slope have the meanings indicated above. (See introduction on "Curves.")

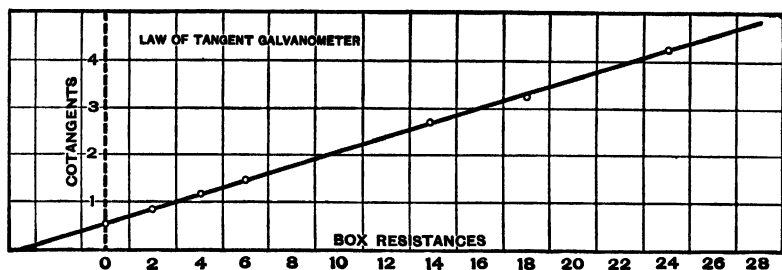

Fig. 81.

Addenda to the report:

(1) Explain, using diagram showing the relation of the magnetic field due to the current following in the galvanometer coils and the earth's field, why the plane of the coils must be in the magnetic meridian.

(2) What additional data, if any, would be necessary in order to find the value of H ? Show how H would be computed.

(3) Show that for the two coils used the ratio of the I_0 's is inversely as the number of turns. The mean radii of the two coils are considered as equal.

The following data are typical of the results to be obtained, and will serve to indicate the method of arranging and tabulating readings. The curve given in Fig. 81 shows the graphical method of testing the deviation of the instrument from the law of tangents.

LAW OF TANGENT GALVANOMETER.

| Resistance in Box. | Galvanometer Readings. | | Mean Deflection. | tan δ . | cot δ . | I_0 . |
|--------------------|--------------------------|--------------------------|------------------|----------------|----------------|---------|
| | Direct. | Reversed. | | | | |
| 0 | { N. 62°.5 S. 62°.0 } | { N. 63°.0 S. 63°.5 } | 62°.70 | 1.937 | 0.516 | 0.613 |
| 2 | { N. 50°.6 S. 50°.0 } | { N. 50°.0 S. 50°.2 } | 50°.20 | 1.200 | 0.833 | 0.625 |
| 4 | { N. 41°.5 S. 41°.0 } | { N. 41°.0 S. 41°.2 } | 41°.20 | 0.875 | 1.142 | 0.623 |
| 6 | { N. 34°.8 S. 34°.2 } | { N. 34°.5 S. 35°.1 } | 34°.80 | 0.695 | 1.439 | 0.616 |
| 10 | { N. 25°.5 S. 25°.0 } | { N. 25°.5 S. 26°.0 } | 25°.50 | 0.477 | 2.096 | 0.628 |
| 14 | { N. 20°.4 S. 19°.8 } | { N. 20°.1 S. 20°.6 } | 20°.20 | 0.368 | 2.718 | 0.627 |
| 18 | { N. 17°.0 S. 16°.5 } | { N. 17°.0 S. 17°.6 } | 17°.00 | 0.306 | 3.271 | 0.610 |
| 24 | { N. 13°.4 S. 12°.9 } | { N. 13°.2 S. 13°.8 } | 13°.30 | 0.236 | 4.230 | 0.620 |
| 30 | { N. 10°.9 S. 10°.3 } | { N. 10°.9 S. 11°.4 } | 10°.90 | 0.193 | 5.193 | 0.621 |
| 50 | { N. 7°.0 S. 6°.5 } | { N. 7° .1 S. 7° .6 } | 7°.05 | 0.124 | 8.086 | 0.613 |

From curve $R_0 = 3.33$ ohms.

“ “ $I_0 = 0.620$ amp.

Last column computed assuming value of R_0 obtained from plot.

The E.M.F. of the battery used in taking the data in the table was 4 volts.

II.

The d'Arsonval galvanometer.

The d'Arsonval galvanometer has several advantages over instruments of the tangent type, since its governing field is very strong and practically constant in direction and amount. It is, therefore, possible to use it in the neighborhood of electrical machinery, even where the external fields are varying and have considerable strength. Since the moving coil must

have metallic leads for carrying the current into and out from the coil, the coil may be supported in such manner as to make the instrument portable. Portable d'Arsonval galvanometers are in general use in portable Wheatstone bridges (Exp. T₁) and commercial electrical testing sets. The commercial direct current ammeters and voltmeters, station or portable, are generally nothing more than d'Arsonval galvanometers.

Connect the galvanometer in series with a battery, a known variable resistance, and a reversing switch, in such a manner as to make it possible to reverse the direction of the current through the galvanometer.

Make scale readings for direct and reverse current for each of at least ten different values of box resistances. It will be found that a very satisfactory set of readings may be obtained by taking resistances from 4 to 40 ohms at intervals of 4 ohms.

From Ohm's law

$$I = \frac{E}{R + R_0} = ks, \quad (230)$$

in which E is the E. M. F. of the battery; R the known box resistance; R_0 the unknown resistance of the circuit, which includes the galvanometer, battery, and connecting wires; k is the constant of the galvanometer expressed in amperes per scale division of single deflection; and s is the number of scale divisions of single deflection; that is, the mean deflection for a given value of the known resistance, from the no current or "zero" reading.

Using values of R as abscissas and corresponding values of the reciprocals of s as ordinates plot a curve. The negative intercept on the axis of abscissas will give the value of R_0 . Taking the value of R_0 obtained from the curve, the known values of E , R , and s , compute values of k for each value of R .

Make a second set of readings as indicated above, using another battery, and treat the readings in the same manner, plotting a curve and computing values of k .

Derive the physical equation of the curves; interpret it, and

obtain all the physical constants possible from the curves. (See notes on curves in the Introduction, and the interpretation of curves in R_1 I.)

Discuss the factors on which the sensibility of the d'Arsonval galvanometer depends. If the galvanometer assigned is very sensitive, *i.e.* a very small current produces a large deflection, it will be found necessary to shunt across its terminals a suitable resistance to reduce the sensibility of the instrument so far as the current flowing in the main circuit is concerned. The constant k thus obtained will refer to the current in the main circuit necessary to produce one large scale division of deflection. The theory of divided circuits is discussed in Experiment R_3 .

EXPERIMENT R_2 . Measurement of current by electrolysis.

One of the most accurate methods of measuring current is by means of the amount of copper or silver deposited in a voltameter through which the current flows.

The voltameter deposit represents the integrated value of the current extending over considerable time; that is, it is a measure of the total quantity of electricity which has flowed through the voltameter. This instrument, therefore, can only give an *average* value of the current. On account of this and other disadvantages, the voltameter is chiefly used to calibrate or determine the constants of instruments which depend for their indications on the magnetic field produced by the current.

In this experiment the spiral coil voltameter devised by Professor H. J. Ryan is to be used.* Two coils are to be prepared for each cell by wrapping copper wire on cylindrical forms. The size of the coils depends somewhat on the strength of the current used. There should be not less than 50 sq. cm. of surface of the coil per ampere. With a current of from one to three amperes, a coil made of one and a half meters of wire of 1.5 mm. diameter will give satisfactory results.

* See Ryan, Transactions of the American Institute of Electrical Engineers, vol. 6, p. 322.

The coils should be of about the same length, but should differ in diameter by 3 or 4 cm., so that the smaller may be placed inside the other without danger of touching. (See Fig. 82). At one end of each coil the wire is to be brought out parallel with the axis for several inches for convenience in making connections. These two coils are to be used as the electrodes of a voltameter cell, current passing in through the outer coil and leaving the cell by the inner coil. The amount of copper deposited in a known time is then sufficient to determine the average current flowing. (One coulomb deposits 0.000328 gram of copper.) The amount of copper dissolved is always slightly in excess of the amount deposited, and for various reasons is not so reliable a measure of the current.

In preparing the gain coils, great care must be used to have them thoroughly clean. A wire of suitable length for the purpose should be fastened by one end and then cleaned with sandpaper. The wires should be carefully wiped with filter paper to remove all copper dust, sand, and grit, taking care to keep the fingers off that portion of the wire which is to receive the deposit. A failure to observe these precautions may make the deposit flake off and necessitate a new set of observations.

When thoroughly cleaned, the wire is coiled upon a suitable form, the latter being first covered with clean filter paper. After cleaning with the sandpaper, the coil should not be touched by the hand anywhere except at its terminal. If this work has been well done, the coils will be ready for use without any further cleansing. If not, pass the coil through a non-luminous Bunsen flame to remove oil, plunge it in a very dilute solution

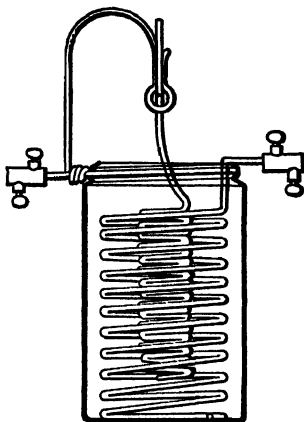

Fig. 82.

of sulphuric acid, and then into distilled water. To dry the coil rapidly and without danger of oxidation, it is first rolled on filter or blotting paper until only a thin film of water remains. This is rinsed off by dipping into strong alcohol. After again rolling on filter paper, what little alcohol is left will quickly evaporate, leaving the coil dry and ready for weighing. The loss coil should also be cleansed with sandpaper, but it is unnecessary to use the precautions that are required in the case of the gain coil.

The density of the copper sulphate solution should lie between 1.10 and 1.18. A few drops of sulphuric acid will improve the action of the solution. The direction of the current should be determined by a compass needle before the

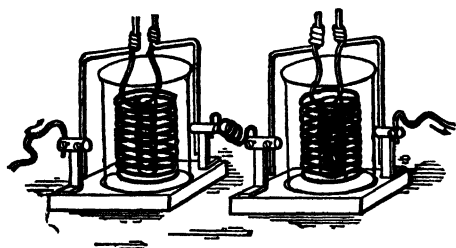

Fig. 83.

voltameter is placed in the circuit. The connections can then be made in such a way as to *make the deposit occur on the inner coil.*

In this experiment the voltameter is to be used in determining the constant of a tangent galvanometer. Two voltameter cells (Fig. 83) are used as a check on the weighings, the two cells being connected in series with the galvanometer and with each other. The connections are outlined in Fig. 84. A reversing switch must be placed in the circuit so that the galvanometer may have the current reversed through it without reversing the current in the other parts of the circuit. There must also be a short circuiting switch in such a position that the current through the galvanometer may be reversed without breaking the remainder of the circuit. The short circuiting key is to be kept open excepting when reversing the direction of the current through the galvanometer.

You will be assigned a galvanometer, a station at which to set up the voltameter cells, and the numbers on the switchboard

of the battery (storage cells) and of the resistance R . Connect these four stations in series on the switchboard, having in all of the adjustable resistance R . Then by means of a compass find the direction of current. Before breaking the circuit adjust R until a single deflection (deflection one way) equal to about 15 large scale divisions is obtained. Open the key at the galvanometer. Adjust the voltameter coils in the circuit so that current flows from the larger to the smaller coils, pour the CuSO_4 into the jars, and close the circuit at the galvanometer, observing the hour, minute, and second. Be sure you know how to manipulate the keys so as to reverse the galvanometer current without breaking the circuit through the voltameters.

A steady current is sent through the circuit for some measured length of time, and the strength of the current is computed from the amount of copper deposited. The deflection of the galvanometer having been also observed, the constant is readily computed. Deflections, both direct and reversed, are to be observed at intervals of two or three minutes throughout the experiment.

The gain coils must be weighed with great care, and placed in the solution only a few minutes before the current is started. At the end of the experiment they should be immediately removed, thoroughly washed with tap water, rolled on filter paper to take off the surplus water, and dried over a Bunsen burner, holding them high enough not to oxidize. The second weighing should be made as soon as possible after the coils are dry and cool.

The constant of any galvanometer may be measured by this method.

In the case of instruments, the sensitiveness of which is so great that currents of the magnitude adapted to the voltameter cannot be measured directly, a shunt of suitable resistance, R_s (Fig. 84), should be placed across the galvanometer ter-

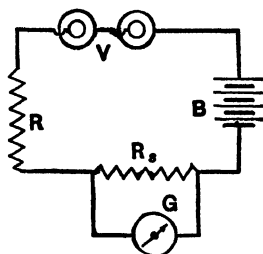

Fig. 84.

minals. The ratio of the current in the voltameter to that which flows through the coils of the galvanometer can readily be computed.

The following table gives the results obtained in the calibration of a tangent galvanometer, and shows the method of arranging them:

GALVANOMETER CONSTANT BY COPPER VOLTAMETER.

| Time. | Galvanometer Readings. | | <i>Other Data and Results.</i> |
|----------|------------------------|-------------------|--|
| | Current Direct. | Current Reversed. | |
| hr. min. | | | Distance of mirror from scale = 50 scale div. |
| | | | Average double deflection = 32.27 " |
| 9 49 | Circuit | completed. | $\tan 2\delta = 0.3227$ $2\delta = 17^\circ 53'$ |
| 51 | — | 42.40 | $\delta = 8^\circ 56\frac{1}{2}'$ $\tan \delta = 0.1573$ |
| 54 | 74.62 | — | Two voltameter cells in series: |
| 57 | — | 42.43 | Before After Gain |
| 10 1 | 74.62 | — | Cathode A . . 27.434 28.686 1.2520 |
| 5 | — | 42.43 | " B . . 27.5715 28.624 1.2525 |
| 9 | 74.68 | — | Duration of run = 3600 sec. |
| 13 | — | 42.39 | Intensity of current $I = 1.059$ amp. |
| 17 | 74.70 | — | For tangent galvanometer, $I = I_0 \tan \delta$; |
| 21 | — | 42.38 | $\therefore I_0 = 6.73$ amp. |
| 25 | 74.67 | — | Galvanometer, one turn, needle at center: |
| 29 | — | 42.32 | Diameter of ring = 77.7 cm. |
| 33 | 74.70 | — | True constant $G = 0.1617$ |
| 37 | — | 42.31 | $I_0 = 10 \frac{H}{G}$; $\therefore H = 0.109$ |
| 41 | 74.57 | — | |
| 45 | — | 42.30 | |
| 49 | 74.56 | — | |
| 49 | Circuit | broken. | |

In your report state Faraday's laws and their bearing on your experiment. Define the C. G. S. unit of current and the practical unit, stating the relation between them. From experimental laws and definitions prove that G , the true or coil constant of a tangent galvanometer, the needle of which is in the plane of the coils, is $\frac{2\pi n}{r}$. What physical meaning has G ? I_0 ?

Compute G and find H . How will the sensibility be affected by changing the magnetic field where the needle hangs? Explain the method used of testing the direction of the current. Explain the telescope and scale method of reading angles and their tangents.

EXPERIMENT R₃. Theory of shunts.

When a current flows in a divided circuit in which there is no E. M. F. the currents in the branches are inversely as the resistances in those branches. For a branch circuit of two parts the relation may be written as follows:

$$\frac{I_1}{I_2} = \frac{R_2}{R_1}. \quad (231)$$

This simple case has many practical applications in electrical measuring instruments; for example, in the ammeter, the voltmeter, and the galvanometer when too sensitive to measure the current directly. In using a sensitive galvanometer to measure comparatively large currents it is shunted by means of a suitable resistance through which a definite portion of the current flows. The current flowing through the galvanometer multiplied by a certain constant called the "multiplying power of the shunt" gives the value of the current in the main circuit at the point of division.

If I_s be used to denote the current through the shunt R_s and I_g the current through the galvanometer branch R_g , analogous to the equation above, the relation showing the division of the current is

$$\frac{I_s}{I_g} = \frac{R_g}{R_s}. \quad (231')$$

Remembering that $I_s + I_g$ is equal to the current I in the main circuit the following equation may be written

$$\frac{I_s + I_g}{I_g} = \frac{I}{I_g} = \frac{R_g + R_s}{R_s}, \quad (232)$$

or

$$I = I_g \frac{R_g + R_s}{R_s}, \quad (233)$$

from which the multiplier of I_g is the "multiplying power of the shunt." Shunting an instrument does not change the sensibility of the instrument itself, but it does alter its constant as a measuring instrument for finding current in the main circuit.

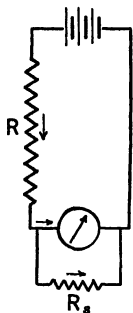

Fig. 85.

The following experiment is intended to verify the relation existing between currents in a simple divided circuit, as given in equations 231 and 233.

Connect a battery, a galvanometer with a reversing key, and a resistance R , at least 100 times the galvanometer resistance, in series. Shunt across the galvanometer terminals a known variable resistance R_s . Under these circumstances the current in the main circuit may be assumed to be constant, no matter how much the resistance R_s in the resistance box is varied. If I stands for current in the main circuit, the above equation to be verified becomes

$$I_g R_s + I_g R_g = I R_s, \quad (234)$$

in which the variables are R_s and I_g .

Observe the reading of the galvanometer with current, both direct and reversed, for a number of different resistances in the box R_s , including the reading when the circuit is broken through the box. This last reading obviously represents the constant current in the main circuit. The resistances taken should be such as to make the galvanometer readings vary by approximately equal steps.

If the resistance of the galvanometer (including connecting wires in multiple with the resistance box) be now measured, sufficient data will be obtained to make a number of verifications of the theory. Since $I_s = I - I_g$, equation 231' may be written

$$\frac{I - I_g}{I_g} = \frac{R_g}{R_s}. \quad (235)$$

This equation can be verified, since every quantity except R_s

is known. This is more apparent when the equation is written in the form

$$R_g = R_s \frac{I - I_g}{I_g}. \quad (236)$$

By substituting in the right hand number of this equation the R_s , $I - I_g$, and I_g of each observation, a series of values of the resistance of the galvanometer R_g is obtained. If these values of R_g thus computed agree, the equation is verified.

As current appears in both numerator and denominator of equation 236 in the first degree, any quantity which is proportional to current may be substituted for it; as the galvanometer deflection, or its tangent.

If the observations be plotted with box resistances as abscissas, and tangents of galvanometer deflections as ordinates,

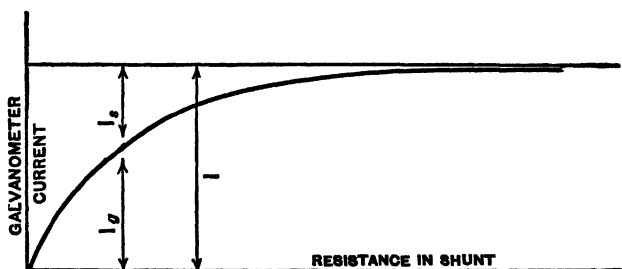

Fig. 86.

the curve obtained will be a hyperbola, with an asymptote parallel to the axis of abscissas. (See Fig. 86.)

If the observations be plotted with *reciprocals* of box resistances as abscissas, and cotangents of deflections as ordinates, the resulting curve should be a straight line, the intercept on the axis of abscissas being equal to $-\frac{1}{R_g}$.

The following table gives a typical set of data from readings, taken with a tangent galvanometer, and shows the method of arranging them. If these results be plotted as indicated above, they will be found to give a curve the form of which is that of Fig. 86.

CURRENTS IN A DIVIDED CIRCUIT.

| Shunt Resistance R_s . | Galvanometer Readings. | | Double Deflections. | Tan δ . | I_g . | $I_0 = I - I_g$. | R_g . |
|-----------------------------|------------------------|-------------------|---------------------|----------------|---------|-------------------|---------|
| | Current Direct. | Current Reversed. | | | | | |
| 8 | 37.55 | 6.40 | 31.15 | .1522 | .01578 | 0 | — |
| 40 | 35.30 | 8.82 | 26.48 | .1302 | .01350 | .00228 | 6.72 |
| 30 | 34.60 | 9.38 | 25.22 | .1241 | .01287 | .00291 | 6.78 |
| 20 | 33.60 | 10.52 | 23.08 | .1140 | .01182 | .00396 | 6.70 |
| 15 | 32.70 | 11.42 | 21.28 | .1052 | .01091 | .00487 | 6.69 |
| 12 | 31.98 | 12.18 | 19.80 | .0980 | .01016 | .00562 | 6.63 |
| 8 | 30.50 | 13.77 | 16.73 | .0830 | .00862 | .00716 | 6.64 |
| 6 | 29.33 | 14.90 | 14.43 | .0718 | .00745 | .00836 | 6.71 |
| 5 | 28.64 | 15.54 | 13.10 | .0652 | .00675 | .00903 | 6.71 |
| 4 | 27.87 | 16.50 | 11.37 | .0566 | .00587 | .00994 | 6.76 |
| 3 | 26.76 | 17.33 | 9.43 | .0471 | .00488 | .01090 | 6.72 |
| 2 | 25.67 | 18.63 | 7.04 | .0352 | .00365 | .01213 | 6.66 |
| 1 | 24.13 | 20.17 | 3.96 | .0198 | .00205 | .01373 | 6.68 |
| 0 | 22.06 | 21.99 | 0.07 | .0004 | .00004 | — | — |

$$I_0 = 103.7 \times 10^{-3}$$

Derive the physical equations of both curves, interpret them, and get all possible physical constants from them. If a d'Arsonval galvanometer be used, be careful to use the proper terms in expressing the current.

EXPERIMENT R_4 . Measurement of the constant of a sensitive galvanometer.

It is frequently impracticable to calculate the constant of a sensitive galvanometer from its dimensions and from the value of the horizontal intensity of magnetism at the point where the needle hangs. The constant of such a galvanometer can best be determined by measuring the deflection of the needle which a *known* current produces. The constant can then be determined from one of the equations:

$$\begin{aligned}
 I &= I_0 \tan \delta, \\
 I &= I_0 \sin \delta, \\
 I &= I_0' s, \\
 I &= k s,
 \end{aligned}
 \tag{237}$$

according to the law of the galvanometer.

There are three principal methods of determining the constant of such a galvanometer, depending upon the method of determining the current flowing through the galvanometer coils.

I.

The current may be measured by means of a galvanometer of small sensibility whose constant is already known. For this purpose it will be necessary to put a shunt across the terminals of the sensitive galvanometer, since the latter will usually be very much more sensitive than the instrument whose constant is already known.

The method of procedure is as follows :

(1) Connect the galvanometer whose constant is known in series with a battery of constant E. M. F., a reversing key, and two variable resistances. One variable resistance is to be placed at the station with the known galvanometer and the other resistance at the station of the sensitive galvanometer where there is to be also a reversing key.

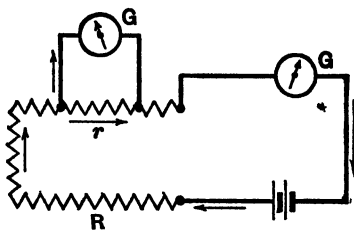

Fig. 87.

(2) Connect the sensitive galvanometer in multiple with the variable resistance box at its station. The resistance in multiple with the sensitive galvanometer should not be less than 10 ohms unless very well known and the variable resistance in the main circuit should be so adjusted as to give a deflection of about 45° if the galvanometer whose constant is known is of the direct reading tangent type, or nearly as large a deflection

as the scale will permit, if the reading is made by means of a mirror.

(3) Adjust the resistance in multiple with the sensitive galvanometer, until its deflection is nearly across the scale, heeding the precaution noted above. It may be found necessary to insert in series with the sensitive galvanometer a high resistance in order to bring the readings within the required range. Observe the readings of both galvanometers for direct and reverse current, and repeat these observations several times to get a good average. As a check, take two other series of observations with different resistances in the circuit, producing deflections varying considerably from the first.

From the deflection of the galvanometer of known constant, the current flowing in the main circuit is known; and from the law of divided circuits, the fraction of the current flowing through the sensitive galvanometer can be computed, provided the *ratio* of the galvanometer resistance to the shunt resistance is known.

Answer the addenda at the end of the R_4 group.

II.

If the galvanometer whose constant is known be replaced by a voltmeter the current in the main circuit can be measured as in Exp. R_2 .

The rest of the experiment is the same as above.

It may happen with a very sensitive galvanometer that a current strong enough to produce a suitable deposit in the voltmeter will require a shunt of excessively low resistance in multiple with the galvanometer.

Under these circumstances, it will be advisable to connect the

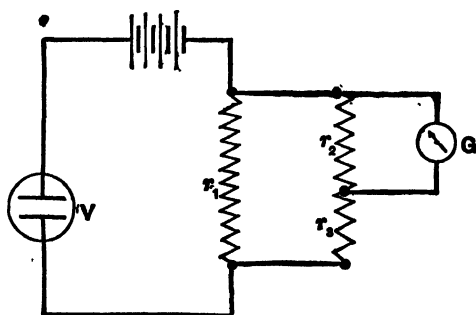

Fig. 88.

galvanometer in multiple with a branch which itself is in multiple with a portion of the main circuit, as in Fig. 88.

If the ratio of the resistance in each pair of branches is known, the current flowing in the coils of the galvanometer may be calculated from the current flowing in the main circuit.

It is to be observed that both of the above methods determine the constant independently of the value of *any* resistance. They simply depend upon a knowledge of the *ratio* of resistances.

III.

The current flowing may be determined from Ohm's law, provided the E. M. F. of the battery is known in volts and the resistance of each portion of the circuit is known in ohms.

For the purpose of this determination, a standard Daniell cell may be very easily constructed as follows: Place an amalgamated zinc rod in a porous cell containing a saturated solution of zinc sulphate. Coil around the porous cell eight or ten turns of rather large copper wire, which has been previously cleaned with sandpaper. Place the porous cell in a larger vessel containing a semi-saturated solution of copper sulphate. The two vessels should be thoroughly cleaned before using.

Such a cell at 15° has an E. M. F. of 1.074 volts. It should be used immediately, although its E. M. F. will change very little for several hours. The internal resistance of such a cell is usually negligible compared with 10,000 ohms. But if it is thought desirable to do so, its resistance may be afterwards determined by the method described in Exp. T₇. Either the Clark or cadmium cell affords a more accurate standard, but either is more difficult to construct, and possess the disadvantage of high internal resistance.

The following is the procedure:

(1) Connect the galvanometer in series with a resistance of at least 10,000 ohms, and the standard cell.

(2) Observe the galvanometer readings, and repeat them several times to get a good average. As a check, repeat these

observations with two or three different resistances in series with the cell and galvanometer. The galvanometer deflection may be deduced from the readings, and the current flowing may be calculated from Ohm's law. An application of one of the above equations will then give the galvanometer constant.

It may happen that the galvanometer used is so sensitive that the deflection is too great to be read even when all the available resistance is in the circuit. In this case the deflection may be diminished as described in part I of this experiment.

In the above it has been assumed that the law of the galvanometer is known. In nearly all galvanometers, some one of the equations given above hold pretty accurately up to 10° or 20° , which is the maximum deflection that should be used with reflecting galvanometers. If the galvanometer deflection is read directly by means of a pointer moving over a graduated scale, the maximum deflection may be much greater.

In all such cases the galvanometer should be calibrated. For this purpose proceed as in any of the above experiments, and observe the resistances that correspond to deflections, varying by approximately equal increments from zero to the maximum reading that the scale admits. At least ten or twelve such observations should be taken.

Plot a curve with currents flowing through the galvanometer as abscissas, and galvanometer deflections as ordinates. This curve is called the calibration curve of the instrument.

If the galvanometer is furnished with a regulating magnet, its exact position should be noted at the time of performing the experiment.

Addenda to the report:

(1) Indicate the difficulties which make it impracticable to calculate the constant of a sensitive galvanometer from its dimensions.

(2) If the instrument considered is a tangent galvanometer, from its constant and the horizontal intensity of the field where

the magnet hangs, calculate the *true* constant of the galvanometer.

(3) If the instrument is a reflecting galvanometer, calculate the constant per scale division.

(4) Discuss the influence of the position of a regulating magnet upon the sensitiveness of the galvanometer. Where should the magnet be placed in order to change the zero point by a few scale divisions and yet have the least effect in changing the galvanometer constant?

(5) How could a magnet be placed quite near a tangent galvanometer and yet have an inappreciable effect, either to turn the needle, or to change the galvanometer constant.

EXPERIMENT R_g. Applications of the galvanometer to the measurement of current.

I.

Measurement of the current from a battery with different arrangements of the cells.

This experiment serves as a study of the conditions under which certain groupings of cells are most advantageous.

Theory indicates that the only case where a multiple arrangement of cells gives a larger current than any other is when the *external resistance* is small. Since the resistance of the galvanometer and connecting wires are included in the external resistance as well as that inserted by means of the resistance box, it follows that if a galvanometer coil is used, the resistance of which approaches that of a single cell, no point will be found where the current for series arrangement is less than that for multiple, and one of the objects of the experiment cannot be accomplished.

For this experiment a galvanometer of small sensitiveness and of very low resistance is required. The galvanometer should have two or three different degrees of sensitiveness, either by having separate coils if a tangent galvanometer or by means of shunts.

(1) Connect a closed-circuit battery* of four or six cells in series with the tangent galvanometer. The circuit should contain also a variable known resistance and a reversing key.

(2) Arrange the cells in series and measure the current for 8 or 10 different box resistances, ranging from 0 to 20 ohms; as, for example, 0, 1, 2, 3, 5, 7, 10, 15, and 20.

(3) Measure the current for two other *groupings* of cells, (*a*) all in multiple, and (*b*) a multiple-series arrangement. The latter

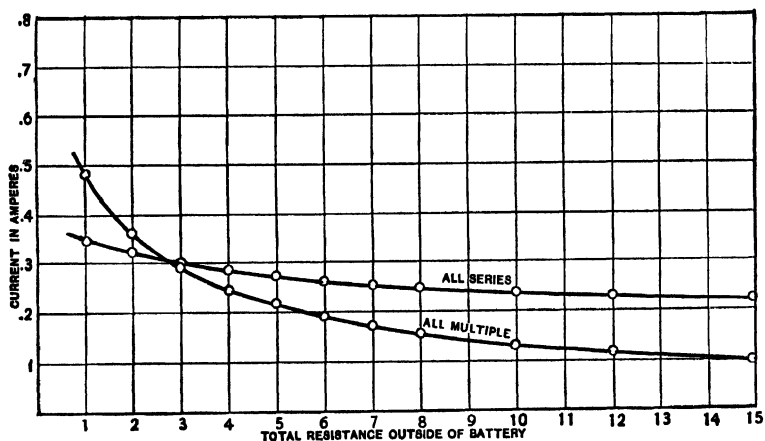

Fig. 89.

grouping may be arranged by dividing the battery into two equal parts, connecting the cells in each part in multiple and then connecting the two parts in series. In both of these arrangements make galvanometer readings for resistances as follows: 0, .5, 1, 2, 3, 4, 5, 6, 8, 10, 12, 15, and 20 ohms. In all cases use the galvanometer coil or shunt that will give the greatest deflection. Changes may be made within a set of readings, noting the resistance at which the change is made.

(4) Obtain the resistance of the galvanometer coils, or shunted galvanometer, and connecting wires including lines leading to the battery. Plot, on the same sheet to the same

* Any battery which does not suffer marked polarization will serve for this pur-

scale, curves with *resistances outside of the battery* as abscissas, and currents in amperes as ordinates.

From the curves determine under what conditions each separate grouping of the cells would produce a greater current than any other grouping. Each curve is an hyperbola. The *point of intersection* of the all-series all-multiple curves gives the resistance of a single cell, provided they are alike. Prove this, and find what the other intersections indicate.

Prove that a group of cells gives a maximum current through a given external resistance when the cells are so arranged that the internal resistance equals that of the external resistance as nearly as possible.

It is well to test separately the cells used in order to find whether each gives the same current under like conditions.

II.

Measurement of current by the Vienna method.

This method is usually employed with currents so large that they cannot be measured directly by ordinary galvanometers or ammeters. The main current is sent through a heavy wire of German silver or similar material, whose resistance changes very little with temperature, and a galvanometer is connected in multiple with this resistance. A constant small proportion of the current will always pass through the galvanometer, and can be measured. From the resistance of the German silver coil, together with that of the galvanometer, the ratio of this measured current to the total current can be computed, and the latter is therefore determined.

The practice of the method may be illustrated by the measurement of the current from a nonpolarizing cell of high electromotive force and low internal resistance. In place of a cell a commercial thermo-battery may be used.

Before beginning the experiment, compute the resistance of the shunt that must be put across the terminals of the galva-

nometer, in order that the maximum readable galvanometer deflection will be produced when the maximum current to be measured flows in the main circuit. This can be done if the galvanometer constant is known; but it will be necessary to assume approximate values for the electromotive force and internal resistance of the battery.

Having determined the proper resistance of the shunt, proceed as follows:

(1) Connect the cell in series with a variable resistance, and with the shunt which is in multiple with the galvanometer.

(2) Observe the galvanometer readings when several different resistances are used in series with the cell. These resistances should vary from one to ten ohms.

(3) Plot a curve with resistances as abscissas, and reciprocals of currents flowing in the main circuit as ordinates. This curve should be a straight line, and from its constants the electromotive force and internal resistance of the cell may be computed.

III.

To investigate the effect of polarization upon current.

(1) Connect a Le Clanché cell, or some other cell that polarizes rapidly, in series with five or ten ohms resistance.

(2) Connect a sensitive galvanometer whose constant is known in multiple with a portion of this resistance, such that the galvanometer deflection is quite large.

(3) Observe the galvanometer readings both direct and reversed every three or four minutes for half an hour or longer. Then break the circuit, stir the solution in the cell, and in the course of ten or fifteen minutes close the circuit, measure the current flowing, and repeat three or four times.

(4) Take another cell as nearly as possible like the first one, and make a similar series of observations, but with a resistance of 50 or 100 ohms in series with it.

(5) Compute the current flowing in the main circuit, and

plot a curve for each cell, with times as abscissas and currents as ordinates.

EXPERIMENT R₆. Calibration of an ammeter.

Connect a storage battery, a variable iron resistance, an ammeter, and a suitable galvanometer in series. Do not put the ammeter so near the galvanometer as to change the controlling field if it be a tangent instrument. Take readings on the galvanometer, direct and reversed, and corresponding readings on the ammeter, using such values of current as to give ten or twelve nearly equally spaced readings on the ammeter scale.

Compute the galvanometer currents and put ammeter readings in a column parallel with said computed currents. Find the error of the ammeter reading.

Find the zero correction for the ammeter and correct readings taken for the zero error. Find the errors of these corrected readings and their percentage errors.

Plot a curve, using calculated galvanometer currents as abscissas and corresponding ammeter readings as ordinates. The same scale should be used on both axes.

Plot another curve, taking ammeter readings as abscissas and corrections, not considering the zero error, as ordinates. It is advisable to put the x -axis in the middle of the sheet on account of having plus and minus errors to plot.

Describe the construction of the ammeter used, and if it is "dead beat," explain why.

CHAPTER X.

GROUP S: DIFFERENCE OF POTENTIAL AND ELECTRO- MOTIVE FORCE.

(S) *General statements*; (S₁) *Ohm's method for the measurement of the E. M. F. of a battery*; (S₂) *Fall of potential in a series circuit*; (S₃) *Potential difference at the terminals of a battery as a function of the external resistance*; (S₄) *Fall of potential in a wire carrying current*; (S₅) *Betz' method of measuring electromotive forces*; (S₆) *Lines of equal potential in a liquid conductor*; (S₇) *Variation in the E. M. F. of a thermo-element with change of temperature*; (S₈) *Calibration of a voltmeter*; (S₉) *Comparison of electromotive forces*; (S₁₀) *The potentiometer.*

(S) **General statements concerning difference of potential and electromotive force.**

The indiscriminate use of the terms "electromotive force" and "difference of potential" has given rise to much confusion. The following treatment of the subject, though different from that of many writers, is believed to be entirely consistent with the facts. Moreover, it is hoped that it will make clear to the mind of the student the relation between two ideas which, though intimately related, are nevertheless entirely distinct.

The difference of potential between two points is that difference in condition which tends to produce a transfer of electricity from one point to the other point. The *measure* of this difference of potential is the amount of work that would be done by or against electrical forces in carrying unit quantity of electricity from the one point to the other point. From definitions it follows

that whenever electricity is transferred along a circuit, between two points a and b , work is done according to the relation

$$W = k(V_a - V_b)It.$$

The difference of potential between a and b is one electromagnetic unit, if work is done at the rate of 1 erg per second, when the current flowing is one electromagnetic unit. This choice of unit potential difference makes k unity in the above equation. The electromagnetic unit of electromotive force is that electromotive force which is capable of producing unit difference of potential. It may be proved that the electromagnetic unit of electromotive force is produced whenever unit magnetic lines of force are cut at the rate of one per second. The practical unit of difference of potential is called a "volt." It is equal to 10^8 electromagnetic units.

Any generator of electricity (whether it be a battery, dynamo, or electrical machine) is capable, when energy is supplied to it, of *maintaining* a difference of potential between its terminals, even though they are connected by a conductor. It is to this capability of maintaining a difference of potential that we apply the name of *electromotive force*. The electromotive force of a generator is measured by the *maximum* difference of potential which it is capable of producing when no current flows. Or, when a current is allowed to flow, it is measured by the difference of potential at the terminals, plus the fall of potential due to the resistance of the generator.

From these definitions it follows :

(1) That there is a difference of potential between any two points of a circuit conveying a current.

(2) That the electromotive force of a circuit is always *located* in the generator. The source of a counter electromotive force may always be looked upon as a negative generator. So far as our present knowledge extends, there is never any electromotive force in a perfectly homogeneous conductor which is not moving relatively to a magnetic field.

The above meaning of the term "electromotive force" is always in mind when it is said that a given conductor is the *seat** of an electromotive force, as in the case of a wire moving in a magnetic field; also when it is said that there is no electromotive force in a given branch of a multiple circuit. Counter electromotive force is the negative of electromotive force, *as above defined*.

Ohm's law as originally stated, using modern terms, is: *The current flowing in a (perfectly homogeneous) conductor (not moving relatively to a magnetic field) is directly proportional to the difference of potential between the terminals of the conductor.* If the conductor between two points is in any way varied subject to the above conditions, the current will be *equal* to the difference of potential between the points divided by a quantity known as the resistance of the conductor between the points. From which we have

$$I = \frac{V_a - V_b}{R_{ab}}, \text{ or } I = \frac{dV}{dR}. \quad (238)$$

The statement that the current flowing in a *circuit* is equal to the total electromotive force in the circuit, divided by the total resistance of the circuit, is a *deduction* from Ohm's law.*

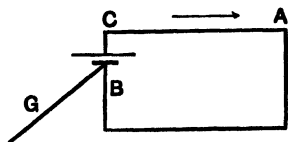

Fig. 90.

The above discussion may be fixed in the mind of the student by the following graphic treatment of two particular cases.

Let *BC*, Fig. 90, be the two poles of a cell whose electromotive force is two volts, and internal resistance four ohms. The negative pole of the cell is maintained at zero potential by being grounded, and the two poles are connected by a homogeneous conductor of twelve ohms' resistance: *CA* four ohms, and *AB* eight ohms.

If a curve be plotted showing the relation between potential and resistance, with resistances counting from *A* in the direc-

* See Gray's *Absolute Measurements in Electricity and Magnetism*, pp. 142-146.

tion of the current as abscissas and potentials for ordinates, the result will be as given in Fig. 90 a. From A to B the potential falls uniformly; between the negative pole and the liquid there is a finite difference of potential represented by BB' ; in the liquid, supposed homogeneous, there is a fall of potential at the same rate as in the outside conductor; between the liquid and the positive pole there is a finite difference of potential

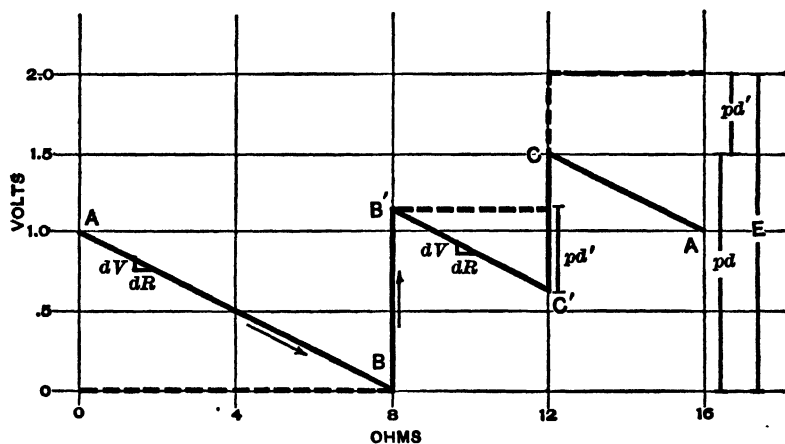

Fig. 90 a.

represented by $C'C$, and from C to A the potential falls at the same rate as before, reaching, of course, the original value.

By the application of Ohm's law the current, $I = \frac{dV}{dR}$, may be derived from any part of the circuit that is homogeneous. The result is obviously the same whether increments of potential and resistance are infinitesimal or of any magnitude.

If the conductor is cut at A , Fig. 90, then the potential of AB will immediately fall to zero. As no current flows, there will be no fall of potential in the liquid; the potential of C will therefore immediately rise by the amount of the former fall through the liquid. The broken line represents the potential in the cell and conductor after the circuit is broken. The electromotive force of the cell E is measured by the maximum differ-

ence of potential between its terminals when no current flows. This is obviously equal to $pd + pd'$, in which pd is the difference of potential between the terminals before the circuit is broken, and pd' is the fall of potential in the cell due to its resistance. It is obvious from the geometry of the figure that $\frac{E}{R}$, in which R is the total resistance of the circuit, gives the same value for the current as $\frac{dV}{dR}$ taken in any homogeneous part of the circuit.

Figure 91 represents the potential as a function of the resistance in a circuit, in which the generator is a dynamo.

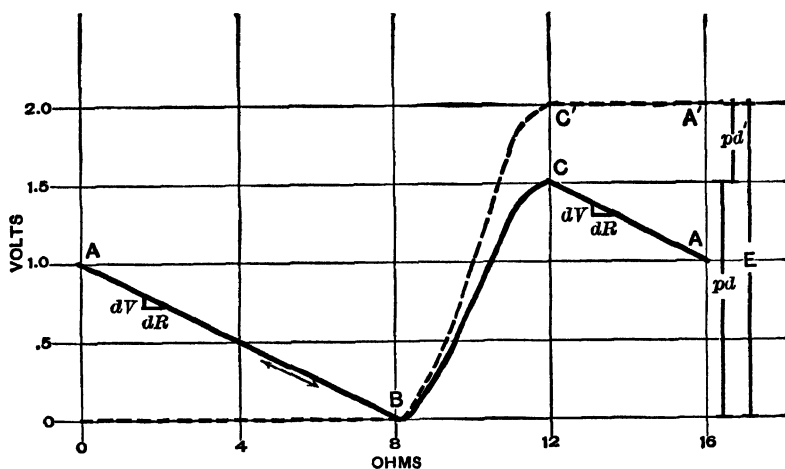

Fig. 91.

In this case the potential is not a discontinuous function of the resistance. The electromotive force is not located at a point (or at a surface) in the circuit as in the case of a cell, but it exists in all those parts of the armature which cut lines of force. With this exception, the above discussion applies to the present case, word for word. If the circuit is broken as before, the broken line shows the condition of affairs, provided that the *resultant** magnetic field remains unchanged after the circuit is

* By *resultant* field is meant the field that is the resultant of the field due to the field magnets and to the current in the armature coils.

broken. This assumption does not hold true, of course, in the case of the series-wound dynamo.

The above graphic representations of the potentials in a conductor carrying a current bring prominently forward the fact that in a conductor not containing an electromotive force the current always flows from points of higher potential to points of lower potential; but that in a conductor or in that part of it containing an electromotive force producing a current, the current always flows from points of lower to points of higher potential.

From the discussion given above, it is seen that Ohm's law may be stated in two forms,

$$I = \frac{\rho d}{R}, \quad (239)$$

for a part of a simple circuit not containing a generator or source of electromotive force, in which a circuit is flowing, ρd being the potential difference between two points separated by a resistance R ; and

$$I = \frac{E}{R}, \quad (240)$$

for a complete simple circuit in which E is the sum of all the electromotive forces and R the total resistance.

The two equations are not identical, the distinction arising from the difference between "potential difference," ρd , and electromotive force, E. M. F., made above.*

A more general form of Ohm's law, which may be applied to a complete simple circuit or to a part of a circuit in which there is or is not an E. M. F., is expressed in the form :

$$I = \frac{(V_A - V_B \pm E)}{R}. \quad (241)$$

Let Fig. 92 represent a part of a complete circuit in which there is included between A and B a resistance R and an E. M. F. acting to send current in the direction BA , although

* See also Ayrton, Practical Electricity, vol. 1, pp. 359-364.

current is flowing from A to B , as indicated by the arrow, due to some generator not shown. The difference of potential between A and B may be considered as

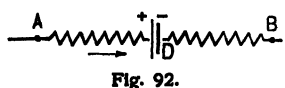

made up of two parts, one being that due to the current I flowing through the resistance R between A and B , the other due to the electromotive force, which in the case shown would make the potential of A higher than B by an amount E .

$$V_A - V_B = \rho d = IR + E. \quad (242)$$

If the conditions of the circuit were as indicated above, except that the E. M. F. be acting in the opposite direction, then

$$V_A - V_B = \rho d = IR - E. \quad (243)$$

The general expression for the current in a simple circuit may be written, therefore, as in equation (241), or

$$I = \frac{(E - \rho d)}{R}. \quad (244)$$

Equations 239 and 240 are readily seen to be particular cases of equation 244. If the points A and B are taken farther and farther from the generator, they may be made to coincide; then $V_A - V_B = \rho d = 0$, and equation 244 becomes that for a complete circuit, equation 240. If by the path chosen from A to B there be no E. M. F., then equation 244 reduces to the form for a part of a simple circuit carrying current, in which there is no E. M. F., equation 239.

The potential difference at the terminals of a generator, be it battery or dynamo, is often called the *external E. M. F.*, and the E. M. F. proper is called the *total E. M. F.* The difference of potential at the terminals of a motor, the primary of a transformer, etc., is often called in practice an *impressed E. M. F.* It must be remembered that an *external E. M. F.* and an *impressed E. M. F.* are properly "potential differences."

For many circuits that appear complex there may be found equivalent simple circuits, as in Exps. R_4 , S_3 , or S_4 and in S_5 , S_8 , S_9 , and S_{10} , when the galvanometers in the parts of the

circuits containing the standard cells show no current flowing through them.

In the more complex circuits, those containing electromotive forces in more than one branch, there are two simple methods of solution: first, the superposition method, and, second, a method based on Kirchhoff's laws. In the superposition method the E. M. F.'s in each branch are taken as effective separately in sending current through all parts of the circuit, the other E. M. F.'s not acting. The final values of the currents are found by taking the algebraic sums of the currents in the various branches produced by the separately considered E. M. F.'s. In many cases the superposition method is very cumbersome and another method based on Kirchhoff's laws is found to be simple and more direct.

Kirchhoff's laws are derived from Ohm's law and may be expressed as follows:

1. In any closed circuit, whether simple or made up of shunts or mesh, the sum of the electromotive forces around any closed path is equal to the fall of potential around that closed path, due regard of course being paid to the signs. Expressed mathematically, the law takes the following form:

$$\Sigma(IR) = \Sigma E. \quad (245)$$

2. The sum of the currents flowing to a point must be equal to the sum of the currents flowing away from it; or, at a point

$$\Sigma i = 0, \quad (246)$$

the currents flowing away from the point taking the minus sign.

In any but constant currents the laws must be used with caution (and the second breaks down entirely with variable currents if there be appreciable capacity).

For an example of the application of Kirchhoff's laws, see Exp. T₇ III, Mance's Method of Measuring the Internal Resistance of a Battery.

In applying Kirchhoff's laws, the following suggestions may be found useful:

1st. Assume a direction of current through the network, and then build up the equations consistent with this assumption.

2d. Use both laws; for if only the first is used, the equations will not be independent.

3d. If there are n unknown currents to be found, there must be n simultaneous equations.

The accompanying example will illustrate the method. I , E , and R refer to the current E. M. F. and resistance in each branch, including the resistance of the battery. The direction of current is assumed as indicated,

$$\text{From law 2, } I_1 + I_2 + I_3 = 0.$$

$$\text{From law 1, } I_1 R_1 - I_2 R_2 = E_1 - E_2.$$

$$\text{From law 1, } I_2 R_2 - I_3 R_3 = E_2 - E_3.$$

If the E. M. F. and resistance of each branch are given, then from these equations the currents may be found. The absolute values of the currents will be correct, since the resistances are known and also the E. M. F.'s are known in direction as well as amount. Since all of the currents cannot flow up to the junction point of the branches, the sign of one or more will be found to be negative, thus indicating the current to be flowing in the opposite direction to that assumed.

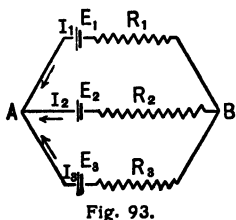

Fig. 93.

EXPERIMENT S₁. Ohm's method for the measurement of the E. M. F. of a battery.

The object of this experiment is the determination of an E. M. F. in absolute measure, without reference to any standard cell. From Ohm's law we have

$$I = \frac{E}{R + R_0}, \quad (247)$$

in which R_0 is the constant unknown resistance of the battery, connecting wires, and galvanometer; and R is the known resistance which may be varied at pleasure.

The procedure is as follows :

(1) Place in a simple series circuit the battery whose E. M. F. is to be determined, a known variable resistance, and a tangent or d'Arsonval galvanometer whose constant is known. A reversing key should be placed in the circuit to enable readings of the galvanometer to be made for both directions of current through it.

(2) Make a series of direct and reverse readings of the galvanometer for at least ten known box resistances, within the range

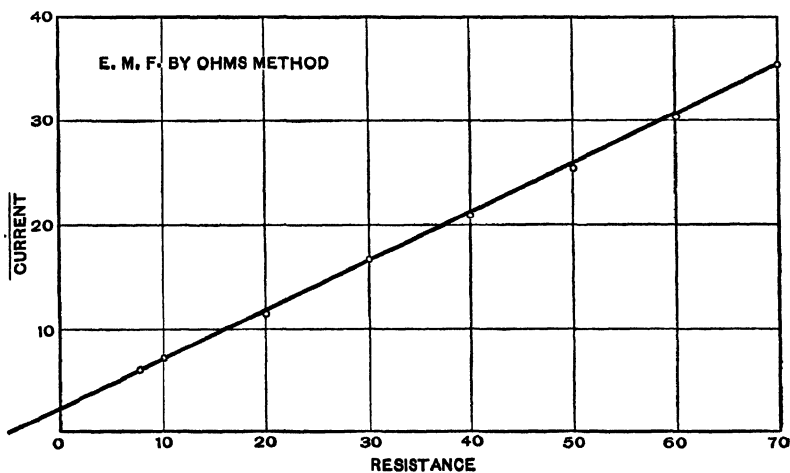

Fig. 94.

0 to 40 ohms, beginning with the smallest resistance that will keep the galvanometer readings on the scale, and proceeding by approximately equal steps.

Make another set of readings within the same range for some other battery, as directed.

From any pair of observations in either set two equations may be obtained between which R_0 may be eliminated and E determined in volts. The best results will be obtained if the two resistances are so chosen as to make the two values of the current quite different. It is to be observed that the method depends upon the assumption that the E. M. F. is unaffected

by changes in the current. With some cells this is only approximately true.

The results can be readily computed by graphical methods. To accomplish this, a curve should be plotted with resistances as abscissas, and reciprocals of currents as ordinates. If the E. M. F. remains constant, the curve obtained should be a straight line, and from the "pitch" of this line E can be computed.

Plot such curves for each set of observations taken. From the values of R_0 , obtained from the curves, the observed data, and the galvanometer constants compute values of E for all resistances used. Derive the physical equation of the curves, and interpret it. Obtain as many physical constants as possible from the curves. From two pairs of suitably chosen observations * in each set find the values of R_0 by elimination.

The following table presents typical data, using a tangent galvanometer, the results of which are shown graphically in Fig. 94.

E. M. F. BY OHM'S METHOD. — TWO GRAVITY CELLS IN SERIES.

| Box Resistance. | Galvanometer Readings. | | Double Deflection | $\tan \alpha \delta$. | $\alpha \delta$. | $\tan \delta$. | Current. | $\frac{E}{\text{Current}}$ | E. M. F. |
|-----------------|------------------------|-------|-------------------|------------------------|-------------------|-----------------|----------|----------------------------|----------|
| | Right. | Left. | | | | | | | |
| 7 | 95.70 | 49.04 | 46.66 | 0.4666 | 25° 1' | 0.2218 | 0.1686 | 5.93 | 2.14 |
| 10 | 90.66 | 53.88 | 36.78 | 0.3678 | 20° 11' | 0.1780 | 0.1353 | 7.39 | 2.12 |
| 20 | 83.15 | 61.28 | 21.87 | 0.2187 | 12° 20' | 0.1080 | 0.0821 | 12.18 | 2.11 |
| 30 | 79.92 | 64.47 | 15.45 | 0.1545 | 8° 47' | 0.0767 | 0.0583 | 17.15 | 2.08 |
| 40 | 78.19 | 66.09 | 12.10 | 0.1210 | 6° 54' | 0.0603 | 0.0458 | 21.84 | 2.09 |
| 50 | 77.11 | 67.13 | 9.98 | 0.0998 | 5° 42' | 0.0498 | 0.0384 | 26.05 | 2.14 |
| 60 | 76.35 | 67.85 | 8.50 | 0.0850 | 4° 52' | 0.0425 | 0.0323 | 30.96 | 2.12 |
| 70 | 75.90 | 68.42 | 7.48 | 0.0748 | 4° 17' | 0.0374 | 0.0284 | 35.22 | 2.15 |

Distance of mirror from scale = 50 scale divisions.

Galvanometer constant $I_0 = 0.76$ amperes.

From curve $R_0 = 5.7$ ohms, $E = 2.14$ volts.

Last column computed assuming value of R_0 obtained from curve.

* See Introduction, p. 4.

EXPERIMENT S₂. Fall of potential in a series circuit.*

The potential difference between two points in a circuit is defined as the work done in transferring a unit quantity of plus electricity from one point to the other. From Ohm's law it follows that the potential difference between two points between which there is no E. M. F. along the path traveled may be expressed as follows: $\rho d = Ir$, in which ρd is the potential difference, I the current flowing, and r the resistance between the points considered. Whenever a current flows through a resistance, there is always a disappearance of electrical energy. The energy reappears in some other forms, as in heat.

The E. M. F. of a battery or a dynamo is equal to the greatest possible potential difference between its terminals; that is, when the generator is allowed to give no current, being on "open circuit." As soon as the battery or dynamo is allowed to give current, the circuit being closed, the difference of potential between its terminals no longer equals its E. M. F., but is less, owing to a loss of potential due to the work done in sending current through the generator itself, the generator having resistance. The loss of potential inside the dynamo or battery will be equal to the internal resistance multiplied by the current flowing. From the above we get the following expressions for a simple circuit.

When no current is flowing, $\rho d = E$ between the generator terminals. When a current is flowing, then $\rho d = E - Ir_b$, where ρd is the potential difference between the generator terminals, E the E. M. F. of the generator, r_b its resistance, and I the current flowing through it.

If there is more than one source of E. M. F. in a circuit, it may be that the current will flow through one generator in a direction opposite to that in which it would send current if free to act alone. If this is the case, the ρd between its terminals

* This experiment is taken from Blaker and Fisher, Experiments in Physics, second edition, 1910.

will be expressed by the following relation: $\mathcal{P}d = E + Ir$, because the $\mathcal{P}d$ must not only be sufficient to send current through the cell owing to its having resistance, but also to overcome an opposing E. M. F. (See p. 273.)

Instruments used to measure E. M. F. and $\mathcal{P}d$ are called potential galvanometers or voltmeters. Such instruments must have comparatively high resistances and must be sensitive, since very little current is supposed to flow through them. If such an instrument be placed in series with a generator, the current flowing is very small, consequently the loss of potential within the generator is also very small and the $\mathcal{P}d$ is very nearly equal to the E. M. F. of the generator.

If a potential galvanometer or a voltmeter be shunted around a resistance, very low in comparison, the current flowing through the instrument will be negligible in comparison to that flowing through the resistance, and the $\mathcal{P}d$ between the terminals of the resistance will not be appreciably disturbed by the presence of the potential measurer.

Suppose a high resistance galvanometer of the tangent or d'Arsonval type be in shunt with a resistance, around which the $\mathcal{P}d$ is wanted. Then $\mathcal{P}d = Ir$. (248)

The current through the galvanometer is

$$I_g = \frac{\mathcal{P}d}{R_g} = I_0 \tan \theta \text{ or } ks, \quad (249)$$

according to the type of galvanometer used, R_g being the total resistance in the galvanometer branch of the circuit.

From equation 249, $\mathcal{P}d = R_g I_0 \tan \theta$ or $R_g ks$. (250)

Equation 250 shows that the $\mathcal{P}d$ is proportional to the $\tan \theta$ or the number of scale divisions of single deflection, the products $R_g I_0$ or $R_g k$ being the potential constant of the instrument.

(1) To calibrate the potential galvanometer, arrange a circuit to send current from one or two cells through a tangent galvanometer whose constant is known or an ammeter and a resist-

ance box in series. Connect the potential galvanometer to the terminals of the resistance box, or a part of known value. Observe the deflections of both galvanometers for five or six different parts of the scale.

Tabulate observed data and the corresponding computed currents and potential differences. Give a working diagram of the connections.

Plot a curve with volts as ordinates and scale readings of the potential galvanometer as abscissas. From this calibration curve the number of volts corresponding to any given deflection may be easily found. If the line is straight, find the fraction of a volt represented by each large scale division.

(2) Connect four cells, three resistances, and an ammeter or non-sensitive galvanometer in series as shown in Fig. 95. Note

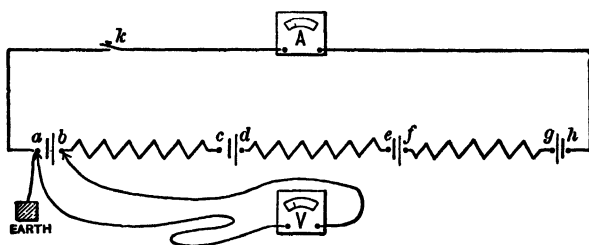

Fig. 95.

that one of the cells is so connected as to oppose the other three. Connect the point *a* to a gas pipe. Its potential will then be zero. Connect the potential galvanometer terminals to points *a* and *b* and observe the deflection. Then connect the terminals to the points *b* and *c* and observe the deflection as before, being careful to note whether the potential rises or falls. Remember that the potential can only fall in a resistance traveling with the current. In like manner make potential readings when connected successively to *c* and *d*, *d* and *e*, and so on to *h* and *a*. The deflection for current in the main circuit should be observed occasionally to determine whether the current remains constant or not. When the *p**d*'s and current have been

measured for a closed circuit, break the circuit and measure the E. M. F. of each cell.

Tabulate the observed data and computations as indicated below. Plot a potential-resistance diagram with resistances as abscissas, taking values from the last two columns of the table. This curve must show the potential differences in the cells as well as in the external resistances.

Draw conclusions from the diagram in regard to the following:

- (1) The fall of potential in the external resistances.
- (2) The fall or rise of potential through the voltaic cells.
- (3) The meaning of the slope of the lines.
- (4) The tests for accuracy.

VARIATION OF POTENTIAL IN A SERIES CIRCUIT.

| Current Galv. | | Parts of Circuit. | Potential Galv. | | | Resistance in Ohms. | E. M. F. of Cells. | | Total from <i>a</i> | |
|---------------|-------|------------------------------|-----------------|--------------------------|--------------------------|---------------------|--------------------|----------|---------------------|--------|
| Reading.* | Amps. | | Reading.* | Volts Rise in Potential. | Volts Fall in Potential. | | Reading.* † | Volts. | To | Volts. |
| | 0.218 | <i>a</i> Cell No. 1 <i>b</i> | | 1.582 | | 1.0 | 1.80 | <i>b</i> | 1.582 | 1.0 |
| | 0.218 | <i>b</i> R_1 <i>c</i> | | | .436 | 2.0 | | <i>c</i> | 1.146 | 3.0 |
| | 0.218 | <i>c</i> Cell No. 2 <i>d</i> | | .128 | | 4.0 | 1.00 | <i>d</i> | 1.274 | 7.0 |
| | 0.218 | <i>d</i> R_2 <i>e</i> | | | .654 | 3.0 | | <i>e</i> | .620 | 10.0 |
| | 0.218 | <i>e</i> Cell No. 3 <i>f</i> | | 1.291 | | .5 | 1.40 | <i>f</i> | 1.911 | 10.5 |
| | 0.218 | <i>f</i> R_3 <i>g</i> | | | .872 | 4.0 | | <i>g</i> | 1.039 | 14.5 |
| | 0.218 | <i>g</i> Cell No. 4 <i>h</i> | | | 1.018 | 1.0 | .80 | <i>h</i> | .012 | 15.5 |
| | 0.218 | <i>h</i> R_4 <i>a</i> | | | .022 | .1 | | <i>a</i> | -.001 | 15.6 |
| | | Totals | | | | | | | | |

One scale division of potential galvanometer = volts.

One scale division of ammeter = amperes.

* Observed.

† Circuit broken.

In plotting the diagram it is well to arbitrarily assume that the E. M. F. of the cell consists of two parts; half being between the zinc and liquid and half between the liquid and copper (or carbon), and the liquid itself offering a resistance to the current which causes the ρd to be less when the current is flowing than on open circuit. Thus $\rho d = E - Ir_b$ where r_b is almost entirely the resistance of the liquid in the cell.

Following this statement, plot one half the E. M. F. of the first cell on zero resistance, $1.8/2 = 0.9$ volt in the diagram. Then the fall in potential through the cell resistance of 1 ohm is

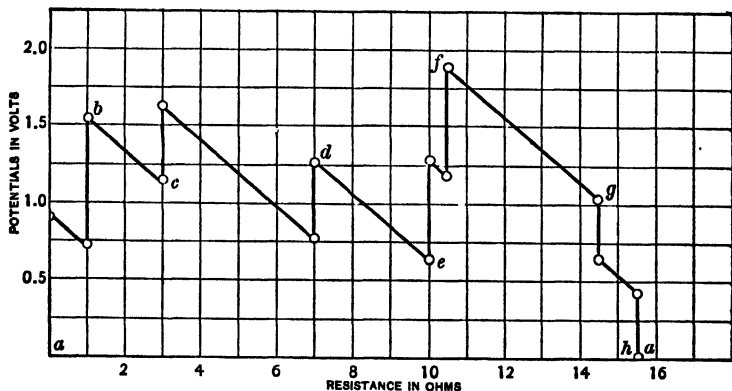

Fig. 96.

$1.8 - 1.582 = 0.218$ volt. $0.9 - 0.218 = .682$ volt, which is the potential to be plotted at 1 ohm. Then we have the other half of the E. M. F. of the cell (0.9) to plot vertically above the second point, bringing the ρd up to 1.582 for 1 ohm as shown in the last two columns of the table and to the point b of the diagram.

From point b to c there is no E. M. F. but there is a fall of potential of 0.436 volt through a resistance of 2 ohms, hence $1.582 - 0.436 = 1.146$ volts, which is plotted at the total resistance of 3 ohms, the point c of the diagram. Here the potential rises again by one half the E. M. F. of the second cell, then falls 0.872 volt through the cell liquid resistance of 4 ohms, and then rises the other half of the E. M. F. to the point d .

The same process is followed for the remainder of the circuit excepting cell $g-h$, which being in opposition to the other cells causes the potential to drop instead of to rise.

Notice that the lines of the diagram have the same slope. The slope = pd/r = current, and since the current remains nearly constant the lines should have nearly the same slope.

EXPERIMENT S₃. The potential difference at the terminals of a battery considered as a function of the external resistance.

The difference of potential between the terminals of a cell has its greatest value when the external resistance is infinite (when the circuit is broken), and is then equal to the electromotive force. As the external resistance is diminished, the

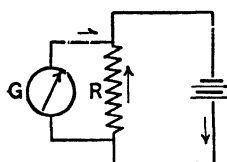

Fig. 97.

E.M.F. remains constant; but the difference of potential between the poles steadily grows less, until the external resistance is zero, when the two poles are at the same potential.

The relation between these two quantities may be investigated as follows:

(1) Put a battery and a variable known resistance in series.

(2) Connect a high resistance galvanometer through a reversing key to the terminals of the resistance box. (See Fig. 97.) The resistance of the galvanometer used should be so great (1000 ohms or more) that the current passing through it is too small to modify appreciably the current in the main circuit. Under these circumstances, the galvanometer merely serves to measure the difference of potential between the terminals of the cell. If the galvanometer is very sensitive, it may be necessary to put a resistance in series with it in order to decrease the current in that branch of the circuit. The added resistance is to be treated as a part of the galvanometer resistance.

Let I_g be the current flowing in the galvanometer, R_g its

resistance, and ρd the potential difference between its terminals; then we have

$$\frac{\rho d}{R_g} = I_g = I_0 \tan \delta.$$

The product $R_g I_0$ is a constant for which may be substituted the symbol ρd_0 . This is the constant of the instrument used as a potential galvanometer,

$$\therefore \rho d = R_g I_0 \tan \delta = \rho d_0 \tan \delta. \quad (251)$$

When R_g is very great, this will be very nearly the potential difference that would exist if no galvanometer were used. It may be here noted that the potential difference between the terminals of the galvanometer, the battery, and the resistance box are practically identical, since the connecting wires are supposed to have negligible resistance.

(3) Observe the reading of the galvanometer for the following box resistances: ∞ , 40, 30, 25, 20, 15, 12, 10, 8, 6, 4, 3, 2, 1, 0.5 ohms. These resistances will be such that the galvanometer deflections vary by approximately equal steps.

If I is the current in the resistance box, R its resistance, and R_b the resistance of the cell, including the connecting wires to the box, we shall have

$$I = \frac{E}{R_b + R} = \frac{\rho d}{R},$$

or
$$\rho d R_b + \rho d R = ER. \quad (252)$$

If the observations taken be plotted with box resistances as abscissas, and potential differences as ordinates, the resulting curve should be a hyperbola, with an asymptote parallel to the axis of abscissas.

If the observations be plotted with *reciprocals* of box resistances as abscissas, and cotangents of galvanometer deflections as ordinates, the curve should be very nearly a straight line, whose intercept on the axis of abscissas is equal to $-\frac{I}{R_b}$. R_b may also be obtained from the first curve. It is the abscissa

corresponding to the ordinate which is half the maximum ordinate.

If the constant ρd_0 is not known, any quantity that is proportional to the potential difference may be substituted for it in plotting the curve, as tangents if a tangent galvanometer

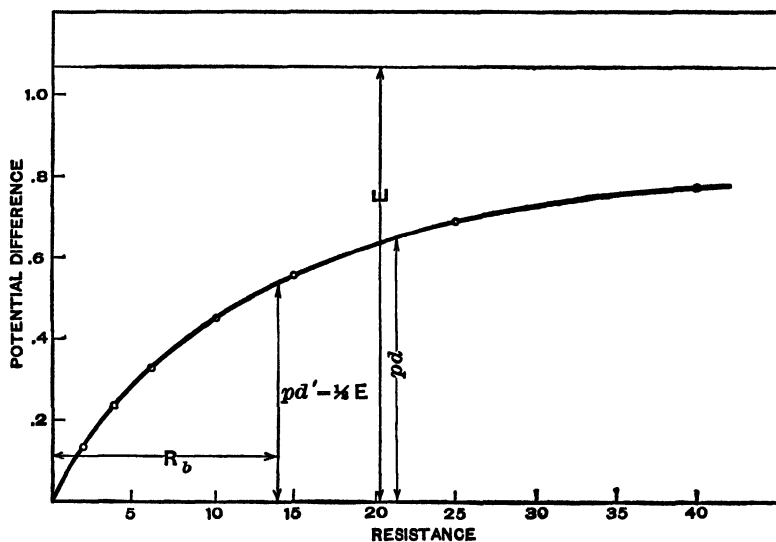

Fig. 98.

be used, or single deflections if the galvanometer be of the d'Arsonval type.

Two sets of observations are to be made, one set with a single cell, and another set with two similar cells in series, one of which is the cell used in the first set.

Compute the potential differences for all observations, and also two values of the battery resistances for each set.

Plot two curves for each set of data obtained. Derive the physical equations of the curves, interpret them, and get the possible physical constants.

Results obtained by the method just described are given in the following table. The relation between resistance and potential difference is shown graphically in Fig. 98.

POTENTIAL DIFFERENCE BETWEEN TERMINALS OF GRAVITY CELL.

| Resistance in Box. | Galvanometer Readings. | | Galvanometer Deflection Proportional to ρd . | Potential Difference in Volts. |
|--------------------|------------------------|-----------|--|--------------------------------|
| | Direct. | Reversed. | | |
| ∞ | 65.26 | 9.80 | 55.46 | 1.065 |
| 40 | 58.06 | 17.07 | 40.99 | 0.787 |
| 30 | 56.38 | 18.76 | 37.62 | 0.722 |
| 25 | 55.30 | 19.87 | 35.43 | 0.680 |
| 20 | 53.86 | 21.32 | 32.56 | 0.624 |
| 15 | 51.90 | 23.30 | 28.60 | 0.549 |
| 12 | 50.40 | 24.87 | 25.53 | 0.490 |
| 10 | 49.25 | 26.10 | 23.15 | 0.444 |
| 8 | 47.74 | 27.62 | 20.12 | 0.386 |
| 6 | 45.95 | 29.23 | 16.60 | 0.319 |
| 4 | 43.90 | 31.50 | 12.40 | 0.227 |
| 3 | 42.67 | 32.76 | 9.91 | 0.190 |
| 2 | 41.20 | 34.28 | 6.92 | 0.133 |
| 1 | 39.73 | 35.67 | 4.06 | 0.078 |
| 0.5 | 38.75 | 36.61 | 2.14 | 0.041 |

d'Arsonval galvanometer No. 48.

Resistance of galvanometer = 340 ohms.

Resistance in series with galvanometer = 5000 ohms.

Resistance of galvanometer branch = 5340 ohms.

Current constant of galvanometer per scale division = 360×10^{-8} .

Potential constant = $360 \times 10^{-8} \times 5340 = 192 \times 10^{-4}$.

From curve $R_b = 13.6$ ohms.

EXPERIMENT S₄. Principle of fall of potential in a wire carrying a current.

This experiment is intended to illustrate the fact that the difference in potential between any two points on a simple circuit in which a current is flowing is proportional to the resistance between these points. This proportionality of fall of potential and resistance holds true in the case of any simple circuit, provided that there is no electromotive force between the two points considered. It is a direct consequence of Ohm's law, and may be stated as follows :

$$\rho d = Ir, \tag{253}$$

in which ρd is the difference of potential, r the resistance between any two points of a simple circuit, and I the current flowing.

The most direct method of testing this proportionality would undoubtedly be to measure the difference of potential between selected points of a circuit by means of an electrometer. In this case the measurement would depend upon electrostatic forces, and the current flowing in the circuit would not be modified. The following method will, however, give results

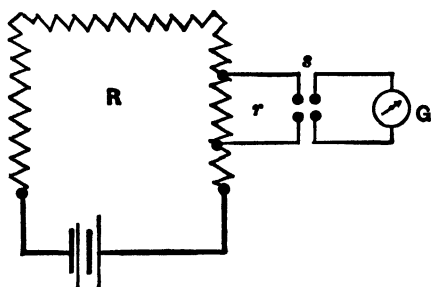

Fig. 99.

that are quite closely correct if the galvanometer resistance is sufficiently large.

The procedure is as follows:

(1) Connect a resistance box in series with a gravity battery of one or more cells, and take out

all the plugs corresponding to the low resistances.

(2) Connect a high resistance galvanometer through a reversing key s to side plugs, and by this means put the galvanometer in multiple with a portion of the resistance in the box (Fig. 99). In order that the galvanometer shall not perceptibly alter the fall of potential in the main circuit, the resistance between the points to which it is connected should not be greater than 0.005 that of the galvanometer. If the galvanometer deflection is not a suitable one, it should be made so by varying the resistance or E. M. F. in the main circuit.

The side plugs should now be shifted from place to place on the box so as to include different resistances between them; and for each value of the included resistance the deflection of the galvanometer (both direct and reversed) should be observed. Ten or twelve different values of the resistance included between the plugs should be used. A suitable series is the following.

one: 30, 20, 17, 14, 10, 9, 7, 6, 5, 4, 3, 2, and 1 ohms. If the galvanometer reading is off the scale when 30 ohms is included between the side plugs, a resistance may be put in series with it.

Since the resistance of the galvanometer remains constant throughout the experiment, the current passing through it is in each case proportional to the difference of potential between the side plugs.

The results may be best used to test the principle of fall of potential by plotting a curve in which resistances between side plugs are used as abscissas and the corresponding galvanometer deflection as ordinates. (If the galvanometer is a tangent galvanometer, tangents of deflections must be used; if a sine galvanometer, sines of deflections, etc.) The curve should be very nearly a straight line, very slightly concave towards the axis of abscissas.

The principles involved in the use of a galvanometer as a voltmeter will be brought out quite clearly if a new series of observations is taken in which the resistances between the side plugs range up to $\frac{1}{5}$ or $\frac{1}{4}$ of the resistance of the galvanometer. This may be done by very greatly increasing the resistance of the main circuit, or by using a low resistance coil, if the galvanometer be a tangent galvanometer of coils of various resistances, or by shunting the galvanometer with a suitable resistance. The same range of resistances may be used as before, but if the deflections are off the scale for the highest resistance, sufficient resistance is to be inserted in the main circuit to bring the readings on the scale. If in this case the observations be plotted as before, there will be a very decided curvature toward the axis of abscissas; but if the true *multiple* resistance between the side plugs be used as abscissas, the curve rigorously becomes a straight line.

Three curves are to be plotted as indicated above, one for the first case and two for the second. The physical equations of the curves are to be derived and discussed, and physical constants obtained.

Addenda to the report:

(1) Indicate the circumstances under which there would be no curvature in a series of observations plotted as above.

(2) Why does the curve become straight when plotted as described in the next to the last paragraph of the directions?

(3) Discuss the characteristics of instruments to be used for measuring current, and for measuring voltage.

EXPERIMENT S₅. Betz's method of measuring electromotive forces.

This experiment depends upon finding two points, *A* and *B* (Fig. 100), in the circuit of the battery whose E. M. F. is re-

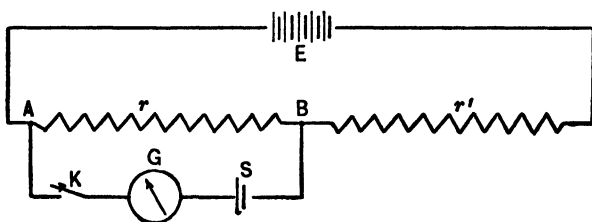

Fig 100.

quired, such that their potential difference shall be equal to the E. M. F. of a standard cell. If r is the resistance between these points, R the total resistance of the circuit exclusive of the battery, whose resistance is R_b , ρd the fall of the potential between *A* and *B* (which is equal to the E. M. F. of the standard cell), the current in the principal circuit will be equal to

$$\frac{E}{R + R_b} = \frac{\rho d}{r}. \quad (254)$$

If a new value of R is taken, r must also be changed. This will give another equation similar to the above, and between them R_b may be eliminated and the ratio of E to ρd computed.

The method may also be employed to determine the battery resistance R_b , but good results cannot be expected unless R is always comparable with R_b .

To perform the experiment :

(1) Connect the unknown E. M. F. in series with two known resistances which may be varied at pleasure. If the current in the main circuit flows from *A* to *B*, connect the negative pole of the standard cell to *B* and the positive pole to a galvanometer. The other terminal of the galvanometer is connected to *A* through a key *K*.

(2) Make the value of the resistance *r* 200 ohms, say; then adjust the resistance *r'* until no current flows through the galvanometer on closing the key *K*.

Under these circumstances the fall of potential from *A* to *B* due to the current in the main circuit is equal to the E. M. F. of the standard cell.

That is,

$$\frac{E}{r + r' + R_b} = \frac{pd}{r}, \tag{255}$$

in which *r* and *r'* are known box resistances and *pd* = *E_s*, the E. M. F. of the standard cell. Make a series of ten determinations of values of *r'* necessary to produce no flow of current through the galvanometer, increasing *r* by 200 ohms at each determination. From any pair of values of *r* and *r'* both *E* and *R_b* may be determined. Use three pairs of suitably chosen values to determine *E* and *R_b*.

Plot a curve using as co-ordinates values of *R* (= *r* + *r'*) and *r'*. This will be a straight line from whose constants *E* and *R_b* may be determined. Derive the physical equation of the curve, interpret it, and determine the physical constants from it.

Taking *R_b* from the curve, compute values of *E* for each observation made.

If the battery whose E. M. F. is to be measured is subject to rapid polarization, the current should be allowed to flow only for an instant before closing the circuit of the galvanometer.

By this method it is obvious that the E. M. F. to be measured must be greater than that of the standard cell. Unless the

galvanometer is very sensitive, it should be three or four times as large.

Addendum to the report:

Show that when no current flows in the galvanometer the potential difference between A and B is equal to the E. M. F. of the standard cell.

EXPERIMENT S₆. To trace the lines of equal potential in a liquid conductor.

The apparatus for this experiment consists of a shallow vessel provided with a glass bottom and filled with some poorly conducting liquid, such as ordinary water. A telephone is also required, and some means of obtaining an alternating or interrupted current. A small induction coil is suitable for this purpose.

If two electrodes are placed in the liquid and a current passes between them, the current will flow from one electrode to the other by every possible path. The potential varies along each of these paths, having its greatest value at the positive pole and its least value at the negative pole. For each value of the potential between these limits, there is therefore a point on each of these "lines of flow." Since all these points are at the same potential, they lie upon one of the equipotential lines of the liquid. The object of this experiment is to determine the shape of these equipotential lines.

Connect two wires to the terminals of the telephone, and fasten one of them so that its end dips into the liquid. If the end of the second wire is also placed in the liquid, a sound will in general be heard in the telephone, due to the rapid make and break of the current. By shifting the position of the second wire, however, a position can be found such that this sound is no longer heard. When this position is reached, the ends of the two wires must be at the same potential, and are therefore points on the same equipotential line. Keeping the position of

the first wire unaltered and varying that of the second, enough points can be found in this way to locate the equipotential line with considerable accuracy. These lines should be traced quite carefully near the edge of the conductor, and in the neighborhood of a line separating a good conductor from a bad conductor. It will be found convenient to place a board ruled with equidistant lines beneath the glass bottom of the vessel, and to record the position of the points by reference to these lines. A diagram can afterwards be drawn on which the equipotential curves are accurately represented. To avoid annoyance from the noise of the interrupter on the induction coil, it is advisable to place the latter in a separate room.

In the manner described above, the form of the equipotential lines may be investigated when electrodes of different shapes are used, or when the relative position of the electrodes is altered. In each case, at least five or six lines should be located, the intervals between them being so chosen that the field in all parts of the liquid is clearly shown. Diagrams should be drawn to scale, representing the position of the electrodes and the limits of the vessel, as well as the equipotential curves. Since the lines of flow must be at all points perpendicular to the equipotential lines, the former can also be drawn.

Very instructive results may be obtained by placing between the electrodes a piece of metal of high conductivity. Since the resistance of the metal is less than that of the liquid, the field will be distorted, and the modified form of the equipotential lines can be determined by the telephone. A piece of some poorly conducting substance, such as glass or paraffin, will also give instructive results.

It may sometimes be desirable to use a galvanometer instead of a telephone in tracing the equipotential lines. In this case, a continuous instead of an alternating current must be used, and the liquid conductor may be replaced by a sheet of tinfoil. The equipotential lines are determined by finding a series of points, such as ~~the~~ if the galvanometer terminals be

connected to any two of them, no current will flow through the galvanometer.

On account of the analogy that has been found to exist between lines of flow and magnetic lines of force, the results of this experiment have important bearings on magnetic problems, such as occur in dynamo work.

Addenda to the report:

(1) Indicate the reason why the equipotential lines are always normal to the edge of the conductor.

(2) Indicate the part of the conductor in which the current density is the greatest.

(3) Indicate the part of the conductor in which the fall of potential is most rapid.

EXPERIMENT S₇. Variation in the E. M. F. of a thermo-element with change in temperature.

There is always a difference of potential between points on opposite sides of the junction between two different metals. If two metals be joined so as to make a complete circuit, there will be a fall of potential at each junction. Since these two changes of potential are equal and are opposed to each other, no current will be produced. In a word, the whole of one metal will be at one potential, while the whole of the other metal will be at a different potential.

This contact difference of potential depends upon temperature. Therefore, if the two junctions are at different temperatures, these two differences of potential will not, in general, annul each other, and a constant current will flow through the circuit. Such a combination of two metals with the two junctions at different temperatures constitutes a thermo-element. It is the seat of a true E. M. F., as that term has already been defined.

It is the object of this experiment to determine the relation between this E. M. F. and the temperatures of the two junctions.

The procedure is as follows:

(1) Construct a simple form of element by soldering together the ends of two wires made of different metals: for example, German silver and copper, or copper and iron. Then cut one of the wires in the center, so that the free ends will form the terminals of the element.

(2) Connect the terminals of the element through a reversing key to a sensitive galvanometer. It will be advisable to place a resistance box somewhere in the circuit, so that the resistance of circuit may be under control. The resistance of the whole circuit should be great enough so that it will not be appreciably altered by changes in the temperature of the element.

(3) One junction of the element is now to be kept at a constant temperature, while the other is placed in a bath of oil or water whose temperature can be readily varied. The E. M. F. corresponding to any observed difference in temperature between the junctions is then proportional to the galvanometer deflections, or its tangent, as the case may be. It is important that the terminals of the element be kept at the same temperature. This can usually be accomplished by placing them side by side and wrapping them with paper.

The junction whose temperature is to be varied should be inserted in a test tube for protection against the chemical action of the bath. Its temperature may be measured by a thermometer placed in the same tube, the bulb of the thermometer being on a level with the junction. To prevent air currents it is best to fill the upper part of the tube with cotton waste or asbestos. For rough work, the other junction may be left in the air, provided it is protected from draughts. It is better, however, to place the junction in some constant temperature bath, such as boiling water, melting ice, or water that is nearly at the temperature of the room. In this case the junction should be inserted in a test tube, as described above.

If two elements mounted in the same frame be supplied, observations are to be made on each element for ten different

temperature differences approximately equally spaced between room temperature and 95° C., the cold junctions being in an ice bath. The bath whose temperature is variable is to be constantly stirred. The connections of the circuit should be so made that by throwing a switch either element may be put in circuit with the resistance box and galvanometer. Such an arrangement will obviate the necessity of heating the variable temperature bath twice. When the bath is at a temperature at which observations are desired, read the temperature of the bath, following it with a direct galvanometer reading on each element, then another temperature reading, then a reverse galvanometer reading on each element taken in the reverse order, and finally a third temperature reading. By taking the mean of the three temperature readings errors due to uncertainty as to bath temperatures will be greatly reduced.

(4) From the galvanometer constant, the resistance of the circuit, and the galvanometer deflections, compute the E. M. F.'s of the thermo-elements for each observed difference of temperature.

(5) Plot a curve with temperature differences as abscissas and E. M. F.'s in microvolts as ordinates for each element used.

Addenda to the report:

(1) Define thermo-electric power and find it for three points on each curve.

(2) Explain how by the method of making observations outlined in part (3) errors of bath temperature are reduced.

EXPERIMENT S₈. Calibration of a voltmeter.

The principle of this experiment is the same as that of Exp. S₆, and it should be preceded by that experiment.

Connect a storage battery B of suitable E. M. F., a protecting resistance such as a starting rheostat, one 100,000-ohm and two 10,000-ohm resistance boxes R , R_1 , and R_2 in series. Connect the voltmeter to be tested in multiple with the two 10,000-ohm boxes. Connect a standard cell S , a galvanometer, a resistance for the protection of the standard cell, and a contact key in mul-

tiple with one of the 10,000-ohm boxes. Figure 101 shows the connections in outline.

Put 5000-ohms in each box R_1 and R_2 and vary the resistance in R until the voltmeter reading is about one tenth of the maximum of the scale.

Adjust the resistances in R_1 and R_2 , keeping the sum equal to 10,000 ohms, until on closing the galvanometer circuit no current flows through the galvanometer. Note the resistances R_1 , R_2 , and the voltmeter reading.

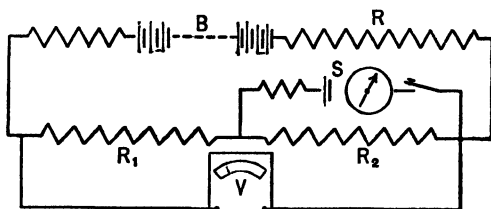

Fig. 101.

The potential difference ρd_2 at the terminals of the resist-

ance R_2 is then equal to the E. M. F. of the standard cell. Knowing ρd_2 and R_2 , the current flowing through R_1 and R_2 may be found. The current multiplied by $R_1 + R_2$ will give the ρd around R_1 and R_2 , which will be the correct voltage.

For the next reading change the resistance of R until the voltmeter reading is about two tenths of the maximum readable voltage on the instrument and proceed as before.

Make ten different determinations of the ρd at the voltmeter terminals.

Plot a curve, using computed values of the potential differences around $R_1 + R_2$ as ordinates and corresponding voltmeter readings as abscissas.

Compute the percentage error of each voltmeter reading when corrected for the zero error of the instrument.

Plot another curve, using the true voltages as abscissas and instrumental errors, plus or minus, as ordinates.

Addenda to the report :

(1) How may a voltmeter be used to measure voltages ten times as great as the range for which it is designed? Explain in detail.

(2) Explain fully how a voltmeter may be used to measure current.

EXPERIMENT S₉. Comparison of electromotive forces.*

I.

Poggendorf's method.

A steady current is sent through a wire resistance AB , Fig. 102, and a regulating resistance R from a storage battery. One of the cells to be tested is placed in series with a sensitive gal-

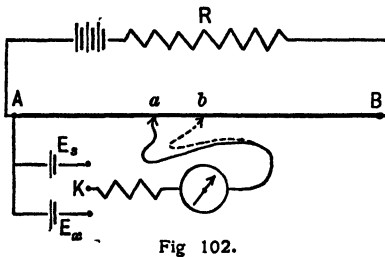

Fig 102.

vanometer and a high resistance, which are then connected to one end of the wire AB at A and to a sliding contact a . The cell is connected so that its E. M. F. opposes that of the storage battery. The position of the sliding contact a is

varied until a point is found where no current passes through the galvanometer. The E. M. F. of this cell is then equal to the fall of potential through the resistance Aa . By means of the three-point switch K , the second cell is inserted in the circuit in place of the first. The position of the connection to AB is varied to some point b until no current flows through the galvanometer. If the current in AB has been constant, the ratio of the resistances Aa and Ab equals the ratio of the E. M. F.'s of the two cells.

Great care should be taken in handling a standard cell. The E. M. F. of a standard cell changes due to polarization when it is permitted to give more than a very small current. To prevent this the high resistance is inserted in series with the cell. However, greater sensitiveness is afforded if this resistance be decreased as a , or b , as the case may be, approaches

* The principles upon which these methods depend are essentially those of Exp. S₈.

the position of balance. If, under these circumstances, the resistance has been decreased, the student must remember to increase it before changing to the other cell.

In connecting up the cells to be tested, if any difficulty is found in getting them in the right direction or the current in the main circuit sufficiently large, the trouble may be ascertained by observing the galvanometer deflection as follows: If while moving a from A to B , the direction of the deflection does not reverse, either the fall of potential along AB is not great enough or the cell is not connected to oppose this potential difference. If the current in the main circuit is reversed and again no reversal of the direction of the deflection is found, the fall of potential in AB is too small.

In this method a wire is used for the resistance AB , along which a sliding contact may be moved (Fig. 102). The lengths of wire Aa and Ab are observed and the ratio of these lengths is equal to the ratio of the E. M. F.'s of the cells.

The current in this wire should be such that the fall of potential wire is but little greater than the largest E. M. F. to be tested. This may be accomplished by varying a resistance in series with the storage cells and the wire AB .

Take three readings for each cell without changing the current in AB . Increase the current so that about 0.9 of the wire is needed to balance largest E. M. F., and take three more readings for each cell. Make a similar set by increasing the current so that about 0.75 of the wire is used for the larger E. M. F.

II.

Lord Rayleigh's potentiometer method.

If a high resistance galvanometer that is quite sensitive is available, this method is more accurate than the slide-wire method, but the principles are the same.

Two accurately adjusted resistance boxes of 10,000 ohms each replace the wire used in I. The resistances R and R' are varied, care being taken to keep the sum of the two constant,

say 8000 ohms, until the galvanometer gives no deflection on closing the galvanometer circuit. The value for R when a balance is obtained may be denoted as R_1 . The other cell is now placed in the circuit and the resistances are changed,

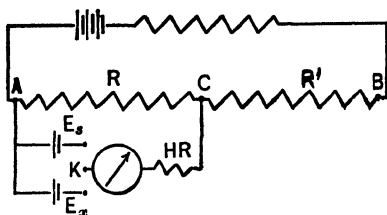

Fig. 103.

keeping their sum the same as before, until the circuit is again balanced. If R_2 be the new value of R ,

$$\frac{R_1}{R_2} = \frac{E_1}{E_2},$$

where E_1 and E_2 are the E. M. F.'s of the cells that are to be compared. The readings should be repeated to be certain that the current in the main circuit has not varied. Repeat, using a constant sum of 10,000, then of 12,000, making for each case the reading described above.

EXPERIMENT S_{10} . The potentiometer.

The principles discussed in Exps. S_5 and S_9 are the basis of a very useful measuring instrument, the potentiometer. The potentiometer may be used to compare E. M. F.'s, resistances, and currents. In any case it is potential differences that are used in making comparisons. If resistances are to be compared, the comparison may be arrived at by comparing the pd 's between their terminals when the same current is flowing in each. Currents may be compared or measured by comparing or determining the pd 's produced by a known current through a known resistance, and of the unknown current through a known resistance, or by comparing the pd of a standard cell with that produced by the unknown current through a known resistance, generally a standard. The following description applies to a particular type of instrument, but the principles involved may be generally used.

The potentiometer consists of a circuit made up of a low resistance battery B (Fig. 104) of small polarization, as of two

or three storage cells, a variable resistance R , 29 coils of equal resistances between b and d , and a wire ab a meter long, divided into millimeters, whose resistance is equal to that of each coil, all in series. A branch circuit, including a standard cell S , a key K , and a sensitive galvanometer G , is connected to the main circuit by the sliding contacts m and n . The contact n

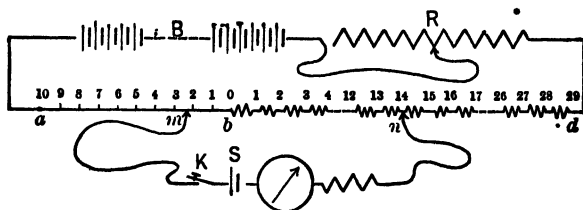

Fig. 104.

may be made to include any whole number of the equal potentiometer coils between b and d , and any equivalent fraction of a coil may be added by means of the contact m sliding over the wire, reading being made on a scale running parallel with the wire.

If the potential difference between a and d due to the current in the main circuit is greater than the E. M. F. of the standard cell S , positions of the contacts m and n can be found such that on closing the key K no current will flow through the galvanometer branch. Under these conditions the pd between m and n is equal to the E. M. F. of the standard cell. If E_1 represents this E. M. F. and N_1 represents the number of coils included between m and n , then the pd per coil will be

$$\frac{E_1}{N_1} = k \text{ (volts per coil).} \tag{256}$$

If E_1 is replaced by a cell of unknown E. M. F. E_2 , and a new balance obtained for which N_2 coils are included between m and n , then

$$E_2 = kN_2, \tag{257}$$

provided the current in the main circuit has not changed.

Computations may be much simplified if k be made some

such factor as 0.1 which will make the instrument direct reading. This may be readily done by making the number of coils included between m and n equal to a multiple of the E. M. F. of the standard cell and changing the current in the main circuit by varying the resistance R until a balance is obtained. As an example suppose a Clark cell, whose E. M. F. is 1.4240 at the particular temperature at which it is used, be put in circuit. If 14 potentiometer coils be included between b and d , the sliding contact m set at 0.240 on the wire, and the resistance R be varied until a balance is produced, the coil factor is then 0.1.

Great care must be used to keep the coil factor constant in making determinations with the instrument. After each observation on the unknown, as well as before, the instrument should be checked by putting the standard cell in circuit. If necessary, the resistance R should be adjusted before each new determination of the unknown.

Before beginning experimental work, carefully trace out the connections of the instrument, making a rough diagram in the notebook with the parts properly designated.

Make connections carefully, find the coil constant, and make a series of observations for determining the unknown potential difference. Make another series of determinations, using a second coil constant. One of the constants may be the factor 0.1, but the other factor should be an odd one for which approximately the maximum range of the coils should be used. Compare results obtained by the two methods.

The problem to be solved will be assigned by an instructor.

CHAPTER XI.

GROUP T: THE MEASUREMENT OF RESISTANCE.

(T) *General statements*; (T₁) *Measurement of resistance by the Wheatstone bridge*; (T₂) *Measurement of resistance by the method of fall of potential*; (T₃) *Specific resistance*; (T₄) *Determination of the temperature coefficient for resistance of carbon and of various metals*; (T₅) *Kelvin double bridge method for measuring low resistances*; (T₆) *Resistance of electrolytes*; (T₇) *Measurement of the internal resistance of a battery*; (T₈) *Measurement of the resistance of a galvanometer.*

(T). General statements concerning resistance.

When two points of a homogeneous conductor are maintained at different potentials, a current will flow in the conductor. The magnitude of this current depends upon the substance and dimensions of the conductor. The *conductivity* of a conductor is that quantity which must be multiplied into the potential difference at its terminals to give the current which flows. The *resistance* of a conductor is the constant ratio between the difference of potential at its terminals and the current which this potential difference produces.

The *absolute unit of resistance* is the resistance of a conductor such that unit electromagnetic difference of potential at its ends will cause unit electromagnetic current to flow. It may be shown experimentally that the resistance of a conductor varies directly as its length, and inversely as its cross-section. On account of the relative ease with which a conductor of some standard substance of given length and section may be constructed, it is more usual to define the practical unit of resistance in these terms. The Chamber of Delegates at the Chicago Electrical Congress adopted, "*As a unit of resistance*

the international ohm, which is based upon the ohm equal to 10^9 units of resistance of the C. G. S. system of electromagnetic units, and is represented sufficiently well by the resistance offered to an unvarying electric current by a column of mercury at the temperature of melting ice, 14.4521 grams in mass, of a constant cross-sectional area, and of a length of 106.3 centimeters."

In current electricity it is necessary to have variable resistances, such that any known value may be inserted in a circuit at pleasure. This demand is met by constructing a series of coils of wire of different resistances and enclosing them in a box, the whole being called a rheostat or resistance box. These coils are constructed of insulated wire, usually of manganin. This alloy of copper, manganese, and nickel has a high specific resistance, thereby giving considerable resistance with comparatively small lengths of wire. It has a low temperature coefficient and a very small thermo-electric force against copper. These coils are non-inductively or doubly wound, so that their self-induction shall be as small as possible. The ends of each coil are connected to separate brass blocks which are electrically connected by removable brass plugs. When all of these plugs are in place, the resistance between the binding screws of the box is inappreciable. Any desired resistance may be introduced into the circuit by removing the plugs corresponding to the proper resistance coils.

In the use of resistance boxes it should always be remembered that the resistance apparently in circuit is not the true resistance unless each plug in place makes good connection between the adjacent brass blocks. If the plug be simply dropped into place, or if it be not thoroughly cleaned, the resistance between it and either brass plug, instead of being infinitesimal, may have a large value. Unless care is taken, the unknown resistance thus introduced into the circuit is likely to be a considerable fraction of an ohm. If the resistances used are small, this becomes of great relative importance. To avoid this difficulty, each plug when it is inserted should be twisted

in its seat, thus securing good contact. Sometimes it is necessary to clean the plugs and brass blocks with sandpaper. Emery paper should never be used.

The coils of resistance boxes are generally wound with small wire, hence they should only be used for weak currents.

EXPERIMENT T₁. Measurement of resistance by the bridge method.

I.

The Wheatstone bridge.

One of the most useful and accurate methods of measuring resistance is by means of the Wheatstone bridge.

Let ABC and $AB'C$ (Fig. 105) be the two parts of a divided circuit containing no E. M. F. If by means of a battery a current is made to flow from A to C , the potential will fall from A to C along both branches. Let B and B' be points in the two branches having the same potential. Let pd and

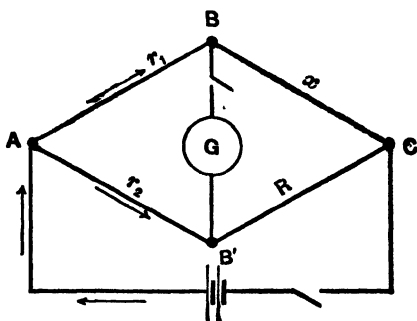

Fig. 105.

pd' be the differences of potential between A and B and between B and C respectively. Let the resistances be r_1 and x . As no current can flow through the branch BB' , we have, from Ohm's law,

$$\frac{pd}{r_1} = \frac{pd'}{x} \tag{258}$$

As B and B' are at the same potential, the difference of potential between A and B must equal that between A and B' . Therefore, in the lower branch we have

$$\frac{pd}{r_2} = \frac{pd'}{R}, \tag{259}$$

whence
$$x = \frac{r_1}{r_2} R. \tag{260}$$

A Wheatstone bridge is an apparatus consisting of three sets of wire coils whose resistances are known. R is a rheostat or variable resistance in which any resistance may be obtained from 0.1 to 10,000 ohms. r_1 and r_2 are called "ratio arms"; each consists of a series of resistances, which may be made 1, 10, 100, or 1000 ohms at pleasure.

To measure a resistance with this apparatus, connect the three sets of resistance coils, r_1 , r_2 , and R , the unknown resistance, a sensitive galvanometer, and a battery, as in the diagram. By removing plugs, make r_1/r_2 any convenient ratio, say 10/100. Vary the resistance in the rheostat until no current flows through the galvanometer connected between B and B' . The unknown resistance may then be computed from the known resistances of three of the four branches.

In measuring resistances with the Wheatstone bridge, two contact keys should be used — one in the battery branch and one in the galvanometer branch. In order to eliminate the effect of thermo-currents, a reversing key should be included in the battery branch.

It is essential for accurate results that the battery key should be closed first, and held closed long enough for the current to become steady, before the galvanometer circuit is completed. Otherwise a deflection may be produced on closing the battery circuit even when the bridge is properly balanced. This is due to the fact that the distribution of a current when first started is determined largely by the relative values of the self-induction in different branches of the circuit, and does not depend solely on the resistances, as is the case when the current has become steady. The effect of disregarding this precaution when measuring inductive resistances, such as electromagnets or the field coils of a dynamo, is always to make the resistance appear larger than it really is.

This fact may be illustrated by selecting as one of the resistances to be measured an electromagnet of rather high self-induction. After the resistance in the rheostat has been so

adjusted that no current passes through the galvanometer when the keys are closed in the proper order, observe the effect of closing the keys in the reverse order. After the galvanometer needle has come to rest, observe the effect of opening the galvanometer key while the battery key remains closed.

Wheatstone's bridge is often made in the form known as the slide-wire bridge. In this pattern r is a rheostat, and the branch $AB'C$ is a straight wire, a meter long, of uniform cross section. At B' there is a key which makes contact with the bare wire. This key is moved along the wire until a point is found having the same potential as B . Since resistance is proportional to length (assuming the wire to be cylindrical and homogeneous), we have

$$\frac{r_1}{x} = \frac{a}{b}, \quad (261)$$

in which a and b are the lengths of the two segments of $AB'C$.

The requirements of the experiment are as follows:

Trace out the connections of the bridge. To do this make a rough diagram of the bridge to be used, as well as an ideal bridge diagram, in the notebook. Then starting from a battery terminal, follow the branch until a point of division is found. Mark this point, and follow out each of these branches, one at a time, until other points of division are found, and so on until the four division points have been located on the actual bridge, and the resistance to be measured has been inserted in the proper place. Note that three, and only three, wires meet at any division point.

Measure at least three resistances, one of which is to be an inductive resistance. Measure the resistances all in series, and also at least two of them in multiple. Use not less than three different ratios in the bridge arms in determining each resistance. Note how to change the ratio arms of the bridge. Compare the measured series and multiple resistances with the computed values, using the single measured values, and explain the principle involved in the computation.

Addenda to the report:

- (1) Explain the effect observed in measuring an inductive resistance if the galvanometer key is closed first.
- (2) Prove that the battery and galvanometer may be interchanged without affecting the balance of the bridge.
- (3) Define the ohm, not using Ohm's law.

II.

*The Carey Foster method of measuring resistance.**

The ordinary form of Wheatstone bridge is not sensitive enough for extremely accurate measurement of resistance, and so other methods have been devised. One of these is the Carey Foster method. Figure 106 shows the usual arrangement for the measurement of resistance by a slide-wire bridge. The point c is moved until the galvanometer shows no deflection, and then from the law of the bridge

$$\frac{R_1}{R_2} = \frac{r \cdot ac}{r \cdot bc'}$$

in which r is the resistance per unit length of slide wire. If R_1 is unknown and R_2 known, then R_1 may be determined.

The Carey Foster method differs from this in that the known and unknown resistances k and x are placed in series with the bridge wire, as shown in Fig. 107.

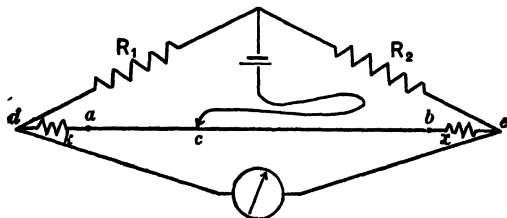

Fig. 107.

* Carhart and Patterson, *Electrical Measurements*, pp. 64-78; Henderson, *Practical Electricity and Magnetism*, pp. 58-62.

If the point c is moved until a balance is obtained, then the following equation must hold,

$$\frac{R_1}{R_2} = \frac{k + r \cdot \overline{ac} + m}{x + r \cdot \overline{bc} + n}, \quad (262)$$

m being the resistance of the connections used to join a , k , and point d ; and n the connecting resistance for the other arm.

If k and x are interchanged, then the point c must be moved to obtain a new balance, unless $k = x$. Let c_1 be this new point,

then

$$\frac{R_1}{R_2} = \frac{x + r \cdot \overline{ac_1} + m}{k + r \cdot \overline{bc_1} + n} \quad (263)$$

Equations 262 and 263 may be written

$$\frac{R_1}{R_1 + R_2} = \frac{k + r \cdot \overline{ac} + m}{k + x + r(\overline{bc} + \overline{ac}) + m + n}, \quad (264)$$

$$\frac{R_1}{R_1 + R_2} = \frac{x + r \cdot \overline{ac_1} + m}{k + x + r(\overline{bc_1} + \overline{ac_1}) + m + n}$$

in which $\overline{bc} + \overline{ac} = \overline{bc_1} + \overline{ac_1} =$ length of slide wire.

Therefore the numerators of second members of these equations must be equal.

$$\begin{aligned} k + r \cdot ac + m &= x + r \cdot ac_1 + m, \\ x - k &= r(ac - ac_1), \end{aligned} \quad (265)$$

in which $ac - ac_1$ equals the distance the point c was moved to obtain the new balance. This method really measures the difference between k and x . R_1 and R_2 do not enter into the final expression, so that any resistance may be used, but it is advisable to have them approximately equal and about the same values as k and x . The resistance of the slide wire per unit length r must be known. The simplest way to determine it is to obtain first the two readings with k and x , then to obtain two more readings with an additional resistance R , about 100 times as large as k , shunted around k . This additional resistance should be fairly accurate, but need not have the same accuracy as k .

The following equations will then hold:

$$\begin{aligned}x &= k + r(\overline{ac} - \overline{ac}_1), \\x &= k' + r(\overline{ac}' - \overline{ac}'_1), \\k' &= \frac{kR}{k + R}.\end{aligned}\tag{266}$$

Eliminating x ,

$$r = \frac{k^2}{(k + R)(\overline{ac}' - \overline{ac}_1 + \overline{ac}_1 - \overline{ac})}.\tag{267}$$

In addition to the apparatus commonly used in measuring resistances with the ordinary slide-wire bridge, the resistances x , k , R , noted above, together with a suitable standard resistance and a commutator switch, whereby the positions of k and x may be interchanged without otherwise disturbing the circuit, are necessary.

The experimental work to be performed is as follows:

The resistances k and x are each to be measured in terms of the standard resistance. Then k and x are to be compared, one in terms of the other. Three independent determinations are to be made for each case. It is necessary to note the position of the wire in series with the standard resistance in the first case in order to find whether k or x is larger. Determine r by the method already described.

The above determinations assume that the value of r remains constant throughout the length of the wire and that the scale on which the lengths are read is correctly graduated. In practice this is not true, hence it is necessary to determine r for various portions of the wire. This determination constitutes the calibration of the wire. To perform this calibration it is necessary to have two coils k_1 and k_2 whose difference in resistance is of such a value as to cause a shift of the point c of a desired length of the portion of the wire to be calibrated. This length will depend upon the accuracy desired. In this calibration the middle two thirds of the wire is to be used, and not less than ten segments compared. The resistances k_1 and k_2 are to be

placed in the positions of k and x in the first part of this experiment. The resistances R_1 and R_2 must be adjustable, so that the point of balance may be located at any desired part of the wire.

Place the contact point c near one end of the part of the wire to be calibrated and adjust R_1 and R_2 until a balance is obtained, or as near a balance as possible, completing it by moving the point c . Then by means of the commutator interchange k_1 and k_2 , and move c until a new balance is obtained. Leaving c in its new position, the commutator is to be put in its original position, interchanging k_1 and k_2 again. Now readjust R_1 and R_2 until there is a balance for the new position of c , as nearly as possible, completing the balance by a movement of the point c , if necessary. The operations just described are to be used to shift the point c from one end of the section studied to the other.

By these operations the difference in the resistance of k_1 and k_2 is determined at different portions of the wire in terms of segment lengths, a comparison of which therefore shows the variation in the resistance per unit length of the bridge wire.

The methods of computation are the same as those used in the calibration of a thermometer in Exp. A₃. (See p. 34.) The readings and computations are to be tabulated as there shown, and a curve is to be plotted, using readings on the bridge scale and corrections as co-ordinates.

EXPERIMENT T₂. Measurement of resistance by the method of fall of potential.

In any part of a simple circuit not containing an E. M. F., we have, from Ohm's law,

$$\rho d = IR, \quad (268)$$

in which ρd and R are the difference of potential and resistance between the points, and I is the current flowing. In any other part of the same circuit, we have

$$\rho d' = IR', \quad (269)$$

the current being the same in all parts of the circuit.

If one of these resistances is known (r , Fig. 108), and the

ratio of the two differences of potential is determined, the unknown resistance may be readily calculated. This ratio may most easily be determined by means of a potential galvanometer. (See Exps. S_3 and S_4 .) In order that the fall of potential to be measured shall not be perceptibly lessened, when the galvanometer is connected to the two points, its resistance should be 1000 or more times as great as the unknown resistance. If the galvanometer resistance is not large, the unknown resistance may still be determined if we know the galvanometer resistance. The relation is proved as follows :

Let pd and pd' be the potential differences between the terminals of the galvanometer, when connected in multiple with the standard and unknown resistance, respectively ; then we have

$$pd/pd' = \frac{rR_g}{r + R_g} / \frac{xR_g}{x + R_g}. \quad (270)$$

This assumes that the *total* current in the main circuit remains constant throughout the experiment.

This method is especially useful in measuring very small resistances. It is commonly used, for example, in determining the specific conductivity of a wire of which only a small sample is available. (See Exp. T_3 .)

It is also a convenient method of measuring resistance in determining the temperature coefficient of a wire (see Exp. T_4), or when the variation of resistance is used to measure temperature changes.

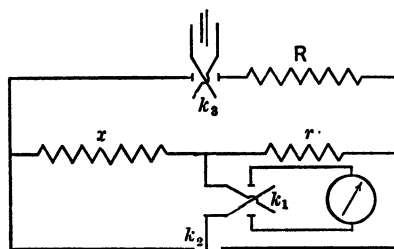

Fig. 108.

The unknown resistance x (Fig. 108) is connected in series with the standard r , a variable resistance R , and a battery of constant E. M. F. (The variable resistance may be a *standard* resistance box.) Since the unknown resistance and the standard are in series, the same current is flowing in each.

The fall of potential is measured by connecting the galvanometer, through a reversing key, first in multiple with the unknown resistance, and then in multiple with the standard, and observing the deflection in each case. The ratio of the two resistances is then equal to the ratio of the tangents of the two deflections, if a tangent galvanometer be used, or to the deflections if a d'Arsonval galvanometer is employed.

In preparing for this experiment, the galvanometer should first be put in multiple with the unknown resistance, and the resistance or E. M. F. in the main circuit varied, until the deflection is a suitable one. Then put the galvanometer in multiple with r by means of the key k_2 and change the value of r until about the same deflection is obtained as when in multiple with x .

The resistance in the main circuit should not be very small, for under these circumstances the battery is more apt to polarize, and the current to change during the experiment.

To eliminate various errors, it is best to have two reversing keys, one k_3 in the battery circuit and the other k_1 in the galvanometer circuit. For each position of the key in the main circuit, the direct and reversed reading of the galvanometer should be observed. The reversal of the main current eliminates errors due to the thermo-currents caused by differences in temperature between different portions of the circuit; while the reversal of the galvanometer circuit eliminates any error that might be caused, when using a tangent galvanometer, by a direct magnetic action of the current in the unknown resistance upon the galvanometer needle.

In taking observations, it is well to alternate between the unknown and standard resistances, so as to eliminate the error which might be introduced by a progressive change in the conditions.

Several independent determinations should be made. This may be done as follows:

(1) Take direct and reversed readings with the galvanome-

ter in multiple with x and then with r for both positions of the switch k_g . Repeat these readings as a check.

(2) Change the value of R cutting down the deflection about one third and repeat (1).

(3) Change the value of r by a few ohms and repeat (1) and (2).

Addenda to the report:

(1) Explain by diagram the necessity of having *two* reversing keys.

(2) Compute the error introduced in your case by using a galvanometer whose resistance was not infinite compared with the unknown resistance.

EXPERIMENT T₃. Measurement of specific resistance.

The specific resistance of a substance is usually defined as the resistance in absolute units of a conductor, 1 cm. long and 1 sq. cm. in cross-section. Specific resistance is sometimes defined in terms of mass instead of volume; *i.e.* it is the resistance of a conductor 1 cm. long whose mass is 1 gram.

If the resistance, length, and cross-section of a wire be measured, it is obvious, since resistance varies directly as length, and inversely as cross-section, that its specific resistance may be readily calculated. The temperature at which the resistance has been determined should be noted and stated.

I.

If the sample furnished has a resistance of several ohms, the resistance may be measured by the method of the Wheatstone bridge. The measurement should be made with great care, using several different ratios, reversing the ratio arms, reversing the battery current, and taking every precaution to make the determination accurate. The temperature of the bridge coils, as well as that of the wire whose resistance is being determined, should be observed. From these data, know-

ing the temperature coefficients of the wire and the bridge coils, and the temperature at which the bridge is correct, the resistance of the wire at 0° can be computed.

II.

If the resistance of the sample to be experimented on is one ohm or less, it should be measured by the fall of potential method and the same series of readings be made as in Exp. T₂.

In either case, the length and diameter should be measured with the greatest care. The diameter may be directly measured in a number of places by means of a micrometer wire gauge; or, better, the mean cross-section may be indirectly determined from the mass, length, and density of the specimen. The density should be determined by weighing in water.

Addenda to the report:

(1) Calculate the specific resistance in terms of volume and in terms of mass.

(2) Compute the relative conductivity, assuming that of copper to be 100.

EXPERIMENT T₄. Determination of the temperature coefficient for resistance of carbon and of various metals.

The resistance of all conductors varies with the temperature, and the temperature coefficient for resistance is defined by the equation

$$R_t = R_0(1 + \alpha t^\circ), \quad (271)$$

in which R_t and R_0 are the resistances at temperatures t° and 0° , respectively, and α is the coefficient. For metals α is positive.

If the material whose temperature coefficient is to be determined is a metal it should be in the form of wire. In using the methods here described, wire should be used which has a resistance of several ohms, in order to have comparatively large absolute changes of resistance, thus decreasing percentage errors in determinations of the changes. The wire should be

wound in the form of a coil, the various turns being insulated from each other.

If the wire is large and stiff, it need not be wrapped with insulating material since it will hold its form, but small wire should be very well insulated and wound on a thin metal cylinder. There should be heavy low resistance current leads soldered to the ends of the coil. For use in the "fall of potential" method there should be a second pair of leads soldered to the terminals of the coil, but it is not necessary that these leads have low resistance.

The coil should be placed in an oil bath whose temperature may be varied at will. The bath should be constantly stirred. Before making readings sufficient time should elapse to permit the coil to attain the desired temperature. This time will be short if the coil be free or wound on thin copper. The temperatures are to be read with a thermometer inserted in the bath.

I.

Method of the Wheatstone bridge.

The heavy insulated copper wires soldered to the two ends of the coil are to be connected to the terminals of the Wheatstone bridge. Make at least ten determinations of the resistance of the coil at approximately equal temperature differences between room temperature and 95°C .

Readings of resistance should be taken both for increasing and decreasing temperatures, and the thermometer should be read before and after each measurement, the mean of the two readings being used. Let the changes of temperature take place *very* gradually, and keep the oil thoroughly stirred.

From the results obtained, plot a curve on cross-section paper, using temperatures as abscissas, and resistances as ordinates. This curve, in the case of most metals, will be very nearly a straight line. Draw a straight line as nearly as possible through all the points, and determine its equation. From this equation determine the temperature coefficient α and the resistance at 0° .

II.

Fall of potential method. (See Exp. T₂.)

In this case, a wire of low resistance may be used. The connections to be made are as indicated in Exp. T₂, the heavy current leads being in the battery circuit. Make the preliminary adjustment of r as in Exp. T₂.

Resistance determinations are to be made at temperature intervals of seven or eight degrees between room temperature and 95° C. Make readings for each determination as follows:

(1) Direct and reverse reading with the galvanometer in multiple with r .

(2) Thermometer reading.

(3) Direct and reverse reading with the galvanometer in multiple with the coil to be tested.

(4) Thermometer reading.

(5) Take reading (3), (2), and (1) in the order named with the battery switch k_3 reversed. The temperature is to be taken as the mean of the three thermometer readings. Compute the unknown resistance, using mean deflections.

For the determination of the temperature coefficient it is not necessary to have any absolute standard of resistance. Since galvanometer deflections are proportional to resistance, we may substitute for R_t and R_0 the deflections δ_t and δ_0 (equation 271), or their tangents, if a tangent galvanometer is used.

After making the necessary readings, a curve should be plotted, with temperatures as abscissas and galvanometer deflections as ordinates. The equation of this line is then to be determined, and from its constants the temperature coefficient and the deflection for 0° C. are to be calculated.

Addenda to the report:

(1) Justify the substitution of galvanometer deflections for resistances in the above equation.

(2) Using the coefficient determined, calculate the resistance at absolute zero of a wire whose resistance is 100 ohms at 0° C.

EXPERIMENT T₅. Kelvin double bridge method for low resistance measurements.

The method devised by Lord Kelvin for measuring low resistances gives determinations of very great accuracy. It may be used to advantage in determining specific resistances

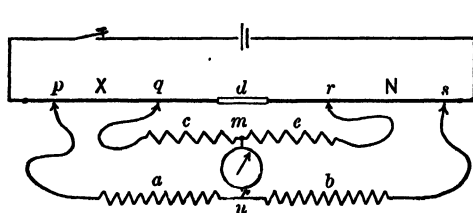

Fig. 109.

and temperature coefficients of small samples.

The specimens to be tested may be made up in the form of bars and may be compared with standard bars.

An outline of the theory of the method is given in connection with Fig. 109.

The resistance X to be measured is connected in series with the standard N and a battery. The connection between X and N should be of low resistance, so that the quantity d , representing the resistance between the points q and r , may be small. The auxiliary resistances a , b , c , and e are connected to the unknown and standard at p , q , r , and s by sliding contacts if X and N are bars, or otherwise by mercury cups or other definite low resistance contact devices. If convenient, the resistances comprised between the contact points p q and r s should be made approximately equal and then adjusted to give zero reading of the galvanometer connecting the points m and n , the ratio a/b and c/e being each equal to unity. When this condition is obtained, then

$$\frac{X}{N} = \frac{a}{b}. \quad (272)$$

The above equation will be true even if the ratios a/b and c/e are not unity, so long as they are equal. If they are not equal, the following relation holds :

$$\frac{X}{N} = \frac{a}{b} + \frac{d}{N} \left(\frac{e}{c+e+d} \right) \left(\frac{a}{b} - \frac{c}{e} \right). \quad (273)$$

This equation is general and is derived in the usual manner from the principle of equal pd 's between p and n , and q and m on the one side of the zero reading galvanometer and equal pd 's between n and s , and m and r on the other side.

It is readily seen that the so-called correction factor $\frac{d}{N} \left(\frac{e}{c+e+d} \right) \left(\frac{a}{b} - \frac{c}{e} \right)$ is zero when a/b is equal to c/e . It is also seen that in the event that such is not quite true, that if d is small compared with N , the correction factor may be neglected. When measuring very small resistances, d may be comparable with N and the ratio a/b not equal to the ratio c/e . It is then necessary to compute the value of the correction factor. In the following experiment, which is mainly one of method, the correction factor may be neglected.

Build up a double bridge, using well-adjusted resistance boxes of the range .1 to 1000 ohms for the auxiliary arms a , b , c , and e , a carefully calibrated box or standard resistance, and the coil or wire whose resistance is to be determined. Use a short length of heavy copper wire to connect the standard and the unknown, and make all connections with the auxiliary resistances of as low resistance as convenient. This does not apply to the galvanometer connections.

Knowing the approximate resistance of X , choose a value of N of the same range. Obtain a "balance" by changing the values of the auxiliary resistances, being careful to keep the ratios a/b and c/e as nearly equal as possible, keeping the smaller resistances in the neighborhood of 100 ohms.

Make two other determinations of the unknown, using different initial values of N . It may be found convenient to use standard resistances of .1, 1, and 10 ohms. If the length and cross-section of the unknown be obtainable, compute its specific resistance.

EXPERIMENT T₆. Resistance of electrolytes.

When a current is passed through an electrolyte, the electrolyte is decomposed, and a counter E. M. F. is always set up. Often there is also an evolution of gas at one or both of the electrodes. These effects complicate the experimental determination of electrolytic resistance, but the difficulties which they introduce may be, in great part, avoided by the use of an alternating current of short period.

The Wheatstone bridge method of measuring resistance may be adapted to the determination of electrolytic resistance as follows:

(1) An alternating current is supplied by replacing the battery by the secondary circuit of an induction coil, or by connecting with an alternating current generator of high frequency and low E. M. F., the circuit being protected by resistance if necessary.

(2) The galvanometer is replaced by some means of detecting alternating currents. A telephone will serve this purpose very well. The method of working is analogous to that described in Exp. T₁. The resistances of the bridge arms are varied until no sound is heard in the telephone, and the unknown resistance is determined by the ordinary law of the bridge. Since the current flowing is a rapidly fluctuating one, it is of the utmost importance that the bridge arms have no self-induction. For this reason, a special form of bridge, such as the Kohlrausch bridge, is one commonly used. It is a slide-wire bridge with a non-inductive variable resistance, the slide wire being wound on a drum.

If the vessel containing the electrolyte is a tube or a prismatic trough with electrodes filling the ends the specific resistance may be computed as in Exp. T₃. In this way we may determine the specific resistance of different solutions, or of the same solution at different temperatures and densities. The temperature of the solution should always be noted at the time of the experiment.

If the vessel used does not admit of accurate measurement, it should be standardized as follows :

(1) Fill the vessel with a solution of known concentration of zinc or copper sulphate at a known temperature and determine its resistance.

(2) From this resistance and the specific resistance of the electrolyte, taken from tables, compute what must be the length of the electrolyte if its cross-section is one square centimeter.

The apparatus having been thus standardized, the specific resistance of any other solution may be determined.

Before putting a solution into the vessel, care should always be taken to scrupulously clean the vessel, and to rinse it with distilled water and a little of the solution to be tested next. The resistance of a solution is sometimes greatly changed by even slight traces of other substances.

Determine the resistances of three solutions and try also ordinary water and distilled water.

Make at least three independent determinations of each liquid used, including the standardizing liquid, using the middle third of the slide wire only. Determine the temperatures of the solutions, and note any changes in temperature during the tests.

EXPERIMENT T₇. Measurement of the internal resistance of a battery.

Open circuit cells or those that do not give constant current when used continuously require different treatment in determining their resistances than those whose E. M. F.'s remain practically constant. Several methods are given below; I-VI being for cells of constant E. M. F.'s, and VII and VIII for cells that polarize.

I.

Ohm's method.

This experiment requires the same observations as Exp. S₁, and the battery resistance may be calculated from the obser-

vations taken in that experiment, provided the resistance of the galvanometer and connecting wires is known. If R is a known resistance, R_b the resistance of the battery, and R_g that of the galvanometer including the connecting wires, we have

$$I = \frac{E}{R_b + R_g + R}. \quad (274)$$

It is not necessary, however, to know the constant of the galvanometer. In the above equation ks or $I_0 \tan \delta$ may be substituted for I , the value of the current, depending on the kind of galvanometer used in the experiment.

If two different values of R be taken, and the corresponding galvanometer deflections observed, we shall have two equations similar to (274). If one of these equations be divided by the other, both E and I_0 will be eliminated, and R_b will be a function of known quantities.

This experiment furnishes an excellent example of the general principles discussed on page 4. The precautions there suggested should be followed here; that is to say, the difference between the two currents in the observations by means of which E and I_0 are eliminated, and R_b is determined, should not be far from the value of the smaller one. Furthermore, the resistances used should be comparable in magnitude with the battery resistance. In order to meet these conditions it will be necessary to use a non-sensitive galvanometer of low resistance, or to adjust a sensitive galvanometer with a shunt of proper resistance placed across its terminals.

The procedure is as follows:

(1) Connect the battery in series with a resistance box, the galvanometer, and a reversing key.

(2) Observe the galvanometer readings for ten different resistances as in Exp. S₁. These readings should be taken several times for each resistance used, and the mean deflection derived from them should be utilized in the computations.

(3) From each suitable pair of observations compute the resistance of the battery.

The resistance of the battery is also to be found graphically, using the method of "least squares" (see p. 24) for locating the line and determining its slope and intercept. The co-ordinates of the curve are to be the known box resistances as abscissas and the reciprocals of currents, or quantities proportional to them, as ordinates.

Derive the physical equation of the curve and interpret it, obtaining physical constants from it.

II.

Thomson's method.

Connections are made as shown in Fig. 110. The resistances R and R_1 are adjusted until a suitable deflection is given by the galvanometer. R is then removed and R_1 adjusted until the galvanometer has the same deflection as before. Call this new value of the resistance R_2 .

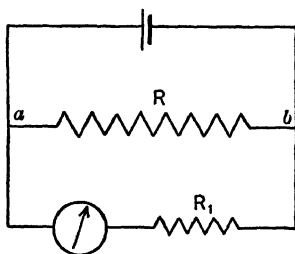

Fig. 110.

In the first case,

$$I_g = \frac{R}{R_g + R + R_1} \frac{E}{R_b + \frac{(R_1 + R_g)R}{R_1 + R_g + R}}, \quad (275)$$

where I_g is the current through the galvanometer, R_b and R_g are the resistance of the battery and galvanometer respectively.

In the second case,

$$I_g = \frac{E}{R_b + R_g + R_2}. \quad (276)$$

Equating the right-hand members of these equations and solving for R_b gives

$$R_b = \frac{R(R_2 - R_1)}{R_g + R_1}. \quad (277)$$

From this equation the resistance of the battery may be computed. As the equation shows, it is necessary to know the resistance of the galvanometer. If, however, the galvanometer resistance is small as compared with R_1 , it may be neglected.

Determine the resistance of two different cells, making five independent sets of readings for each, using different initial conditions for each set.

III.

*Mance's method.**

This method is one of the most accurate ones for a battery that is not subject to rapid polarization. It was originally applied to the measurement of the resistances of cable and telegraph lines as well as of battery resistances.

Although it is not a Wheatstone bridge method, and should not be confused with it in any sense, the equation for finding the unknown resistance has the same form, but cannot be derived in the same manner. The form of circuits for Mance's method and the Wheatstone bridge may be made to look alike. In the circuit for Mance's method the battery to be tested takes the place of one of the four arms, as x in Fig. 105, the galva-

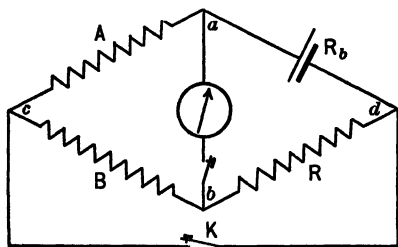

Fig. 111.

nometer is in the usual position, and in place of the battery B' usually used there is a make and break key K , Fig. 111.

The measurement consists in so adjusting the resistances A , B , and R that the opening or closing of the key K has no

effect on the deflection of the galvanometer through which current is flowing all the time. When this condition is reached, the difference of potential between the galvanometer terminals remains constant, *but it is not zero*. When the key K is open the current divides at a , part flowing to b through the resistances A

* Mance, Proc. Royal Soc., London, 1870, Vol. 19, p. 248.

and B in series, and the remainder through the galvanometer. The circuit is completed through R and the battery. It may be shown that the current flowing in the galvanometer branch is

$$I_g = \frac{E}{\left(R_b + \frac{(A+B)G}{A+B+G} + R \right) \left(\frac{A+B+G}{A+B} \right)}. \quad (278)$$

If the key K is closed, the battery current will divide at a , part flowing to the other battery terminal at c through A , considering the key circuit as of negligible resistance; the other part flowing through the galvanometer to b , where it divides and flows through the multiple resistances B and R to the negative terminal of the battery c and d . In this case the current flowing through the galvanometer may be shown to be

$$I_g = \frac{E}{\left[R_b + \frac{A \left(G + \frac{RB}{R+B} \right)}{A + G + \frac{RB}{R+B}} \right] \left[\frac{G + \frac{RB}{R+B} + A}{A} \right]}. \quad (279)$$

For the condition of equal galvanometer deflections for open or closed key K the values of I_g in equations 278 and 279 will be equal, and therefore the denominators of the right-hand members may be equated and solved for R_b , giving

$$R_b = \frac{A}{B} R. \quad (280)$$

If a tangent galvanometer is used in performing the experiment, and the deflection of the galvanometer is too great to be read on the scale, a permanent magnet may be used to bring the needle back. This magnet should be kept as far away as is possible, however, in order not to diminish the sensitiveness of the galvanometer. If a d'Arsonval galvanometer is used, its sensibility may be changed by a suitable shunt. Judgment must be used in the choice of the resistances placed in the various branches of the circuit, so as to secure the greatest sensitiveness and at the same time as little inconvenience as possible

from large and variable deflections. If the resistance of the battery is not very great (thousands of ohms), it will be best to adjust the resistance of the three branches A , B , and R , so that the greatest resistance is in series with the battery and galvanometer.

If the battery polarizes, even very slowly, there will be a drift of galvanometer reading. This change of the current through the galvanometer must, of course, be disregarded. Sometimes the observations are still further complicated by the existence of some small self-induction in the bridge coils. The effect of this is to give the galvanometer needle a slight inductive throw, even though the proper relation of the resistances A , B , R , and R_0 has been reached.

Make ten independent determinations of a battery resistance.

Addenda to the report:

(1) Prove equation 280 for Mance's method by Ohm's or Kirchhoff's laws.

(2) A dynamo is like a battery in the fact that it is the seat of an E. M. F., and has internal resistance. What difficulty would be experienced in measuring, by this method, the internal resistance of a dynamo while running?

IV.

*Mance's method as modified by Lodge and by Guthe.**

Mance's method has been further extended by Lodge and later by Guthe by using a condenser in series with a ballistic galvanometer which makes a "zero" method of it.

The circuit of the modified method is made up as follows:

The cell whose resistance is desired is put in series with a key K and the resistances Q , P , and R . The point D is connected to a blade of the switch S in such a way that when the

* O. J. Lodge, *Phil. Mag.*, 1877, vol. 3, p. 515; Arthur W. Smith, *Science*, vol. N. S. 22, p. 434.

switch is moved the blade passes over the point a connected to A . B is connected to a condenser and C is connected to the galvanometer. The second blade of the switch is connected to the galvanometer and to the condenser from b . Its movable end slides from the point c to the point e , in both of which positions it short-circuits the galvanometer, c and e being permanently connected to the galvanometer. The switch is so made that the contact at c is made before that of the other blade is broken

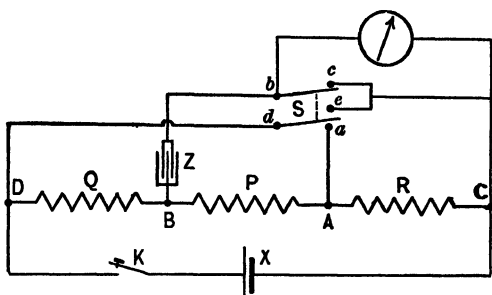

Fig. 112.

at a . This is to eliminate the kick of the galvanometer when the condenser is being charged to its original potential when the switch is moved from e to c .

With the switch on e it is seen that contact at a is broken and the condenser is charged to a ρd , e_1 , equal to the fall of potential through P and R from B to C . This drop is

$$\rho d = e_1 = I(R + P) = \frac{E}{R + P + Q + X}(R + P), \quad (281)$$

where E is the E. M. F. of the cell under test and X its resistance.

Now the switch is moved so that the contact at e is broken, the galvanometer is put in the circuit between B and C , the contact at a is made, thus short-circuiting Q and P , reducing all points between A and D to the same potential. Contact at a is then broken and that at c made, thus restoring conditions in the lower circuit and short-circuiting the galvanometer.

When P and Q are short-circuited, thus bringing them to the same potential, the condenser is charged to some new value e' equal to the ρd between B and C or A and C , since B and A

are at the same potential. Call this new potential difference $\rho d'$, then

$$\rho d' = e' = I' R = \frac{E}{R + X} R. \quad (282)$$

If on throwing the switch from e to c there is no throw of the galvanometer, it indicates that no electricity has passed through the galvanometer. Therefore the potential difference between the terminals of the condenser has not changed and $e' = e_1$.

Equating the right-hand members of (281) and (282),

$$\frac{R + P}{R + P + Q + X} = \frac{R}{R + X'}$$

from which
$$X = \frac{Q}{P} R. \quad (283)$$

The experiment consists in so adjusting the resistances Q , P , R , that no galvanometer throw takes place when the switch is thrown from e to c . If the cell used is one that polarizes rapidly, make Q large (1000 ohms or more). Give R different values, and for each value change P and Q until a balance is obtained.

Make at least a half-dozen determinations of X . If the resistance is very low, put a known resistance in series with it and proceed as before, finding the resistance of the combination.

The method may be used to find the temperature coefficient of the cell resistance.

V.

Fall of potential method for cells of constant E. M. F.

A sensitive galvanometer of high resistance, used to measure potential differences, is connected to the terminals of the battery to be tested. A variable resistance R is also connected to the battery terminals in multiple with the galvanometer. The circuit is connected up as shown in Fig. 110, excepting R_1 , which may be omitted. When the circuit through R is broken. *i.e.*

when R is infinite, the deflection of the galvanometer is proportional to the E. M. F. of the battery,

$$d_1 = kE, \quad (284)$$

in which d_1 is the deflection in scale divisions.

When the circuit is closed through the resistance R , the deflection is proportional to the fall of potential in R ,

$$d_2 = k(v_A - v_B) = kIR.$$

Substituting for I the value obtained from Ohm's law,

$$d_2 = kR \frac{E}{R + R_b}. \quad (285)$$

Dividing (285) by (284),

$$d_2/d_1 = R/(R + R_b), \quad (286)$$

or
$$R_b = R \frac{d_1 - d_2}{d_2}. \quad (287)$$

When $R = R_b$, d_2 is one half of d_1 . A direct method is therefore given by adjusting R until the initial deflection is halved. R is then equal to R_b .

In performing this experiment use two different cells, taking five different values of R for each. The deflection with R infinite should be taken alternately with the readings for the different values of R . Take first a reading with the circuit through R broken, then with R closed, next with R broken, and then with a new value for R , and so on. Remember that the best results are obtained when d_2 is about one half as large as d_1 .

If the circuit is connected as in the figure, the resistance of R_b as found by this method includes the connecting wires a and b for which, if their resistance is appreciable, correction must be made.

VI.

Fall of potential method for open circuit cells.

When the cell is one that polarizes, a condenser and a ballistic galvanometer are necessary. The connections are shown

in Fig. 113. The switch K_1 is for the purpose of charging the condenser, and then discharging it through the galvanometer.

The method pursued is similar to that in V. When the external circuit through R is open, the condenser C is charged and immediately discharged through the galvanometer and the throw noted. As this throw is proportional to the E. M. F., it gives d_1 in equation 284, part V. The resistance R is now inserted and the discharge throw again noted. As this throw is proportional to the fall of potential in R , it gives d_2 in equation 285, part V, above. A number of different resistances should be used. Alternately with these, the discharge for R infinite should be observed. The best results are obtained when the value of d_2 is about half as large as that of d_1 .

The circuit through R should be closed for a very short time, as the cell may quickly polarize. The condenser must however be disconnected from the battery by opening K_1 before this circuit is opened.

Make at least six independent determinations of the internal resistance of a battery.

VII.

*Benton's method.**

This method may be used for cells that do or do not polarize rapidly.

In Fig. 114, G is a sensitive galvanometer of low resistance, E_1 the cell whose internal resistance is to be found, E_2 an auxiliary cell, k a key which closes the circuits $ckE_1R''ac$ and ckE_2dc at the same time. The auxiliary cell E_2 may have either a greater or less voltage than E_1 .

If the internal resistance of E_2 is too small, then another resistance R_2' must be used in series with it.

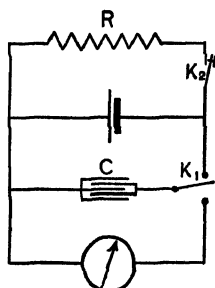

Fig. 113.

* Physical Review, vol. 16, April, 1903, p. 253.

(1) Make R'' equal to zero and R_1 any suitable small resistance. Then change R_2 until such a value is found that on closing the key k no galvanometer deflection is produced.

(2) Give R_1 some much larger value R_1' , and leaving R_2 unchanged, make R'' such a value that no deflection is produced.

Then if R_b be the resistance of cell E_1 ,

$$R_b = \frac{R_1 R''}{R_1' - R_1}. \quad (288)$$

PROOF. Let the upper and lower branches be known as 1 and 2. Since no current flows through the galvanometer for a "balance," the current in all parts of branch 1 is the same. The current in all parts of branch 2 also has a single value.

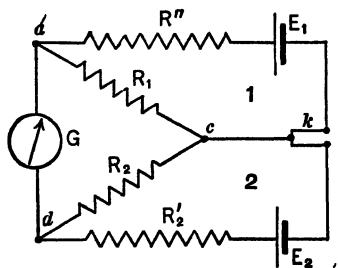

Fig. 114.

For the first adjustment the current in the upper circuit is

$$I_1 = \frac{E_1}{R_1 + R_b} = \frac{{}^a p d_c}{R_1}, \quad (289)$$

and in the lower circuit

$$I_2 = \frac{E_2}{R_2 + R_2' + R_b'} = \frac{{}^a p d_c}{R_2}. \quad (290)$$

Since the galvanometer has no deflection,

$${}^a p d_c = {}^a p d_c. \quad (291)$$

For the second adjustment the current in the upper circuit is

$$I_1' = \frac{E_1}{R_1' + R'' + R_b} = \frac{{}^a p d_c'}{R_1'}. \quad (292)$$

Since no change has been made in the lower circuit the current has the same value as in the first case, therefore,

$${}^a p d_c = {}^a p d_c'.$$

From equations 289 and 292,

$$\frac{E_1 R_1}{R_1 + R_b} = \frac{E_1 R_1'}{R_1' + R'' + R_b}. \quad (293)$$

From equation 293,

$$R_b = \frac{R_1 R''}{R_1' - R_1}. \quad (294)$$

Make six determinations of R_b , varying R_1 , but keeping it comparatively low, not over 20 ohms.

EXPERIMENT T₈. Measurement of the resistance of a galvanometer.

The following methods of measuring the resistances of galvanometers use their own deflections and require no auxiliary galvanometers.

I.

The following method is best suited for high resistance galvanometers.

Connections are made as in Fig. 115. R_s is made so small that its resistance may be neglected in comparison with the resistance of the galvanometer. The resistances are adjusted until a large deflection is obtained, then R_2 is changed until the deflection of the galvanometer is halved. Call this new value of the resistance R_2' . Since the resistance in the galvanometer branch of the circuit has been doubled, we have

$$\begin{aligned} R_2' + R_g &= 2(R_2 + R_g), \\ \text{or} \quad R_g &= R_2' - 2R_2. \end{aligned} \quad (295)$$

If R_2 is zero, the method is further simplified. The resistance R_1 is inserted in the battery circuit as an aid in controlling the value of the initial deflection of the galvanometer.

If a gravity cell is used or any other cell of fairly high resistance that does not polarize, the cell may simply be short-circuited by a wire having a resistance of not over a few tenths of an ohm.

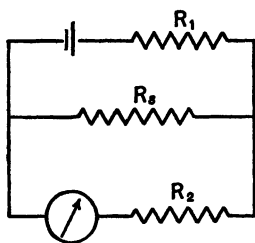

Fig. 115.

Make six independent determinations, varying the initial conditions for each.

II.

Method of equal deflections.

The circuit is connected as in Fig. 115, but no resistance is placed in series with the galvanometer. The lettering and description below apply to that figure.

A known resistance R_s is inserted in multiple with the galvanometer, and the resistance R_1 is varied until a good-sized deflection of the galvanometer is obtained. The shunt R_s is then removed, and the resistance R_1 is changed until the deflection is the same as before. Let this new value be R_2 . From the data obtained in these two adjustments the resistance of the galvanometer may be computed.

In the first case, when the galvanometer is shunted,

$$I_g = \frac{R_s}{R_g + R_s} \frac{E}{R_1 + r + \frac{R_g R_s}{R_g + R_s}}, \quad (296)$$

where I_g is the current in the galvanometer, R_g and R_s are the resistances of the galvanometer and shunt respectively, and r is the resistance of the battery and connecting wires.

In the second case,

$$I_g = \frac{E}{R_2 + r + R_g}. \quad (297)$$

Since the values of I_g are equal, the right-hand members of (296) and (297) may be equated and E eliminated. Solving for R_g gives

$$R_g = \frac{R_s(R_2 - R_1)}{R_1 + r}. \quad (298)$$

In case R_1 is so large that r may be neglected,

$$R_g = \frac{R_s}{R_1}(R_2 - R_1), \quad (299)$$

where all the quantities are known.

The best results are obtained when R_s is nearly equal to R_0 , that is, when R_1 is one half of R_2 .

In performing this experiment several determinations should be made. In the first one a value for R_s is selected at random. Noting the values obtained for R_1 and R_2 and remembering that the most accurate results are obtained when R_1 is about one half of R_2 , more suitable values of R_s can now be chosen. For a complete set of observations, at least six different values of R_1 are to be used. If the resistance of the battery and connecting wires is not accurately known, R_1 must be so large that their resistance may be neglected. On account of their low internal resistance, Edison-Lalande cells are particularly well adapted for this experiment.

Two restrictions on this method may be noted :

(1) When the galvanometer is of low resistance, the resistance R_s will be small and the resistance of the connecting wires must be taken into account.

(2) When the galvanometer is not very sensitive, the resistance R_1 is not usually large enough, so that r , the resistance of the battery and connecting wires, may be neglected. In this case the method is tedious, as a determination of r must be made.

III.

Thomson's (Lord Kelvin's) method.

In this method the galvanometer to be tested is inserted as the unknown resistance in one of the arms of a Wheatstone bridge. In the usual position of the galvanometer (see Fig. 105) a key is inserted. When the bridge is properly "balanced," the key is connected to points having the same potential. Closing the key will therefore cause no change in the current from the battery. But if the bridge is not properly balanced, closing the key will change the current through the galvanometer. Therefore instead of adjusting the resistance until the galvanometer gives no deflection, the bridge is adjusted

until *no change* in the deflection of the galvanometer is observed on closing the key.

For low resistance galvanometers, the slide-wire bridge is best. In using the slide-wire bridge it is always well, after one adjustment has been made, to interchange the positions of the standard and the unknown, the galvanometer in this case. Usually it will be found convenient to build up a bridge, using resistance boxes for that purpose.

In many cases the deflection of the galvanometer will be so great that it will be necessary to diminish it. If the galvanometer is not of the d'Arsonval type, the deflection may be decreased by a magnet. The magnet should be placed so that its field opposes the field due to the current in the galvanometer coils, but does not materially change the earth's field; that is, the magnet should be placed so that the north and south component of its field at the center of the galvanometer is weak. Otherwise, the sensibility of the galvanometer may be so decreased that small changes in the current cannot be detected. In case the galvanometer has two coils that can be connected to different circuits, it may be used differentially, that is, one coil may be measured at a time, and through the other may be sent a current from another circuit in a direction such as to oppose the effect from the coil in the bridge circuit. When these two currents are thus balanced, the resultant deflection is small, yet a slight change in either current is indicated by the needle. This neutralizing current may be obtained by a multiple circuit from the battery that is used in the bridge circuit, and can be regulated by placing a resistance box in series with the galvanometer coil.

When the field due to the coil that is being measured is neutralized by a field either from a magnet or from another current, the observer may be bothered in balancing the bridge by having to readjust the magnet or auxiliary current each time the resistance in the bridge is changed. This trouble is entirely avoided if the adjustment of the bridge is made by changing

both r_2 and R in such a way that their sum remains constant. If a slide-wire bridge is used, the difficulty is avoided by connecting the battery wires to the terminals of the slide wire.

In the case of a d'Arsonval galvanometer, where neither method of decreasing the deflection is available, it will be necessary to weaken the current by placing resistance in the battery circuit or by using two cells of slightly different electromotive force connected so as to oppose each other.

Make six independent determinations of the resistance of the assigned galvanometer, varying conditions of the circuit.

CHAPTER XII.

GROUP U : ELECTRICAL QUANTITY.

(U) *General statements ; (U₁) Constant of a ballistic galvanometer ; (U₂) Logarithmic decrement ; (U₃) Comparison of capacities ; (U₄) Capacity in absolute measure.*

(U) **General statements concerning electrical quantity.**

The electromagnetic unity of quantity is that quantity of electricity which is transferred by unit current in unit time. The practical unit of quantity, the coulomb, is the quantity transferred by a current of one ampere in one second.

The total quantity of electricity transferred by any current is the product of the current by the time during which it continues. If the current is variable, this becomes

$$Q = \int I dt$$

taken between the proper limits.

Quantities of electricity are considered when we deal with

- (1) The total amount of an electrolyte decomposed.
- (2) The charge and discharge of condensers.
- (3) Momentary induced currents.

In cases (2) and (3) the duration of the current is usually very brief, and since the magnetic field produced is equally transient, it is obvious that the quantity of electricity transferred cannot be measured by means of a galvanometer used in the ordinary manner. The quantity of electricity transferred through the coil of a galvanometer by a momentary current can be measured, however, by the "throw" or "swing" of the moving parts due to the magnetic impulse of the momentary current.

A galvanometer used for measuring such impulses is called

a ballistic galvanometer from its analogy to a ballistic pendulum. It may be of either the tangent or d'Arsonval type.

Any galvanometer can be used as a ballistic galvanometer, simply by observing "throws" instead of permanent deflections, provided that the motion of the moving parts be slow enough to determine the end of the swing with accuracy. It is also desirable, in the case of galvanometers used ballistically, that the damping should not be very great. These two requisites are secured by making the moving parts heavy, thus securing slow motion and small factor of decrement. In using a tangent galvanometer ballistically, it must be remembered that the magnetic moment of the needle enters the constant of the instrument. Therefore the needle should be a magnet whose moment is not subject to rapid change.

EXPERIMENT U₁. Measurement of the constant of a ballistic galvanometer.

The following are three methods for determining this constant :

(1) By measuring the throw due to the discharge of a condenser.

(2) By measuring the throw produced by the induced current due to the rotation of a coil in a magnetic field, or a known change of magnetic flux in a solenoid.

(3) By computation from the periodic time of the moving parts of the galvanometer, and the constant of the instrument used as a current measurer.

Methods (1) and (2) may be applied to all galvanometers having little damping. They are also applicable to d'Arsonval galvanometers, which are heavily magnetically damped.*

The third method, the one used in this experiment, may be applied in determining the "quantity constant" of galvanometers in which the damping is small.

* O. M. Stewart, The Damped Ballistic Galvanometer, Physical Review, Vol. XVI, 1903, p. 158.

The theory on which the third method is based is the same in principle whether applied to the d'Arsonval or tangent galvanometer, as will be seen from the following brief discussion.

The d'Arsonval ballistic.

It is assumed that the total quantity of electricity to be measured passes through the galvanometer before the moving coil has moved appreciably from rest; and that the initial velocity ω given to the coil due to the magnetic forces produced by the transient current is the maximum velocity.

The instantaneous value of the magnetic torque (see p. 243) is

$$L_q = \frac{iAf}{10}. \quad (300)$$

But the torque is equal to the moment of inertia multiplied by the angular acceleration, therefore

$$\frac{iAf}{10} = K \frac{d\omega}{dt}. \quad (301)$$

Integrating over the time the current flowed,

$$\frac{Af}{10} \int i dt = \frac{AfQ}{10} = K\omega_0, \quad (302)$$

that is, quantity of electricity is proportional to the angular momentum or moment of momentum $K\omega_0$.

The equation for the quantity of electricity just given is not of practical application. It is possible to get it into a usable form by applying the principles given in Exp. F₂.

The initial kinetic energy is

$$E_K = \frac{1}{2} K\omega_0^2, \quad (303)$$

which is used up in twisting the suspension. At the end of the swing the energy is all potential,

$$E_P = \frac{1}{2} L_0 \delta^2, \quad (304)$$

in which L_0 is the moment of torsion of the suspension and δ the angle of twist.

Since $E_P = E_K$,

$$\frac{1}{2} L_0 \delta^2 = \frac{1}{2} K\omega_0^2. \quad (305)$$

The return torque being proportional to the angular displacement, the motion is S. H. M. and the periodic time is

$$T = 2\pi\sqrt{\frac{K}{L_0}}. \quad (306)$$

By combining equations 302, 305, and 306 and noting that for small angles δ may be written in terms of the scale divisions s and the distance r from the scale to the minor as $\frac{s}{2r}$, K and ω_0 may be eliminated, giving

$$Q = \frac{T}{2\pi} \frac{10 L_0}{Af} \delta = \frac{T}{2\pi} \frac{10 L_0}{Af 2r} s. \quad (307)$$

From the theory of the d'Arsonval galvanometer used as a current measuring instrument (see pp. 242-244) the constant per scale division is

$$k = \frac{10 L_0}{Af 2r}. \quad (308)$$

$$\therefore Q = \frac{T}{2\pi} ks = Q_0' s, \quad (309)$$

that is, the quantity constant Q_0' per scale division is equal to the current constant k per scale division multiplied by $T/2\pi$.

The tangent ballistic.

In the case of the tangent galvanometer the following conditions are to be noted :

(1) The instantaneous value of the magnetic torque acting to displace the needle is

$$L_q = \frac{MGi}{10}, \quad (310)$$

in which M is the magnetic moment of the needle, G the true constant of the galvanometer, and i the instantaneous value of the current.

(2) The potential energy of the needle at the end of its swing is equal to the amount of work done against magnetic forces in turning it through an angle δ (Fig. 116) in a magnetic field of strength H ,

$$E_p = MH(1 - \cos \delta) = 2MH \sin^2 \frac{1}{2} \delta. \quad (311)$$

(3) The periodic time of the needle is

$$T = 2\pi\sqrt{\frac{K}{MH}}. \quad (\text{See } Q_2.)$$

The theory outlined for the d'Arsonval galvanometer under the conditions named above gives the following expression for the quantity of electricity passing through the galvanometer,

$$Q = 10 \frac{T}{\pi} \frac{H}{G} \sin \frac{1}{2} \delta. \quad (312)$$

Now $10 \frac{H}{G}$ is the working constant of the galvanometer,

$$\therefore Q = \frac{T}{\pi} I_0 \sin \frac{1}{2} \delta. \quad (313)$$

The constant multiplying factor of $\sin \frac{1}{2} \delta$ is the ballistic constant of the instrument. Calling this quantity Q_0 ,

$$Q = Q_0 \sin \frac{1}{2} \delta. \quad (314)$$

If the deflections are small, a constant per scale division may be computed as indicated for the d'Arsonval galvanometer.

The above demonstrations assume that the whole of the kinetic energy of the moving parts after the current has ceased to flow is used in overcoming magnetic forces. This is not quite true. The friction of the moving parts against the air and the current induced in the galvanometer coil by the moving magnetic needle both require the expenditure of energy, and therefore make δ or s less than they otherwise would be. The theory of damping leads to the conclusion that $(1 + \frac{1}{2} \lambda)$ should be used as a multiplying factor in the above equations, in which λ is the logarithmic decrement of the galvanometer needle. (See Exp. U₂.)

The experiment is to be performed as follows :

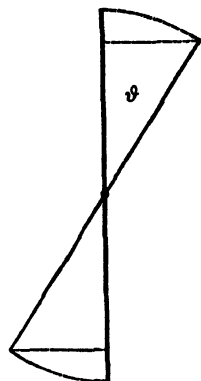

Fig. 116.

I.

Find the current constant k , "figure of merit," per scale division of the d'Arsonval galvanometer by one of the methods of Exp. R₄ or by a potentiometer method of measuring current.

Determine the periodic time by the method of transits, Exp. A₅ II, taking the time at the first, sixth, eleventh, . . . thirty-sixth transits, and repeating the process three times, if the period is not more than 15 seconds. In case of periods greater than 15 seconds use the method of Exp. A₅ I.

Compute the quantity constant in the manner indicated in the theory given above.

II.

If a tangent galvanometer is used, perform the experiment in the manner indicated in I, finding the I_0 of the instrument.

EXPERIMENT U₂. Determination of the logarithmic decrement of a ballistic galvanometer needle.

It has already been shown that the quantity of electricity that passes through the ballistic galvanometer is proportional to the impulse imparted to the needle or moving coil, which, in its turn, is proportional to the sine of half the angle of throw, or to the angle itself, if the latter be small. This is true, however, only when there is no lost energy due to air friction and induced currents, which damp the oscillation of the needle or coil and finally bring it to rest.

Since it is by means of the throw that the quantity is to be measured, we must know the correction that is to be applied to the *actual* throw of the needle to give the throw that would have resulted had there been no damping.

When a vibrating system oscillates under the influence of damping, the ratio of any amplitude to the succeeding one in the opposite direction is very nearly constant, or

$$\frac{\delta_1}{\delta} = \frac{\delta_2}{\delta} = \frac{\delta_n}{\delta} = r. \quad (315)$$

This constant is the "ratio of damping," and its Napierian logarithm is called the logarithmic decrement, and is generally designated by λ . We have, therefore,

$$\lambda = \log_e \frac{\delta_n}{\delta_{n+1}}. \quad (316)$$

The equation of motion of a body oscillating under the action of a force whose moment is proportional to the angular displacement, as has been shown under the head of simple harmonic motion, is

$$K \frac{d^2\phi}{dt^2} + G_0\phi = 0. \quad (317)$$

If the motion is not simple harmonic, but is damped by friction or otherwise, a third term must be introduced. In the case of an oscillating magnet or moving coil damping is produced :

(1) By air friction.

(2) By induced currents. Both of these retarding forces are very nearly proportional to the angular velocity; consequently the term that must be added to the above equation is $k \frac{d\phi}{dt}$, in which k is a constant. The complete equation of motion of the damped magnetic needle is therefore

$$K \frac{d^2\phi}{dt^2} + k \frac{d\phi}{dt} + MH\phi = 0. \quad (318)$$

If we integrate this equation, we have

$$\phi = \delta_0 e^{-\frac{kt}{2K}} \sin \frac{2\pi}{T} t, * \quad (319)$$

in which δ_0 is a constant, and T is the period of oscillation of the needle or moving coil under the influence of damping.

Let time be reckoned from the instant the needle or coil passes the position of equilibrium; and let $\delta_1, \delta_2, \dots$, be the values of ϕ at the times $= \frac{T}{4}, \frac{3T}{4} \dots$. These values of ϕ will

* See Gray's Absolute Measurements in Electricity and Magnetism, vol. 2, p. 393.

be the successive actual amplitudes of the oscillatory motion ;
and

$$\delta_1 = \delta_0 \epsilon^{-\frac{kT}{8K}}, \quad (320)$$

$$\delta_2 = \delta_0 \epsilon^{-\frac{3kT}{8K}}.$$

From these equations we have

$$\log_e \frac{\delta_1}{\delta_2} = \frac{1}{4} \frac{kT}{K}, \quad (321)$$

and by substituting for this quantity λ , as in (316), equation 320 gives

$$\delta_1 = \delta_0 \epsilon^{-\frac{1}{4} \lambda}. \quad (322)$$

Transposing and expanding the exponential in terms of λ , and neglecting powers of λ higher than the first, we obtain

$$\delta_0 = \delta_1 (1 + \frac{1}{2} \lambda). \quad (323)$$

When there is no damping, *i.e.* when $k = 0$, we have, from (320), $\delta_1 = \delta_0$. Therefore it follows that δ_0 is the quantity that should be substituted for the first actual throw in using a ballistic galvanometer, and that equation 310 becomes

$$Q = Q_0 (1 + \frac{1}{2} \lambda) \delta_1. \quad (324)$$

The above demonstration is based upon the assumption that both δ and λ are small. If δ is 4° and the ratio of damping is 1.52, equation 324 will be in error by about one part in a thousand. If δ is 10° and the ratio of damping is 1.2, the error will be about one in a hundred.

The object of this experiment is to determine the logarithmic decrement of a galvanometer, and to show the relation of the decrement to the resistance in circuit with the galvanometer. It is obvious that the decrement must depend on the resistance, since the damping is, in large part, due to the currents induced in the galvanometer circuit and because these currents are inversely proportional to the resistance of the circuit.

In the performance of the experiment, a galvanometer

should be used in which the damping is not very great. From equation 315, we have

$$\frac{\delta_n}{\delta_{n+m}} = r^m, \quad (325)$$

whence
$$\lambda = \frac{1}{m} \log_e \frac{\delta_n}{\delta_{n+m}}. \quad (326)$$

Errors of observation have the least influence when the ratio of δ_n to δ_{n+m} is about 3.

The method of procedure is as follows :

(1) Set the needle or coil to vibrating, and observe the limits of the successive swings to the right and left by means of a telescope and scale.

(2) From these observations determine the successive amplitudes.

The position of equilibrium of the needle or coil will generally be obtained by noting the scale reading when the needle is at rest. Sometimes this position changes during the progress of an experiment. It may then be obtained as follows: Let S_1 , S_2 , and S_3 be three scale readings corresponding to the extremes of successive throws. We shall then have

$$S_0 = \frac{1}{4}[S_1 + S_3 + 2 S_2],$$

in which S_0 is the zero position at the instant when the scale reading is S_2 . The deflection required, then, is, in scale divisions,

$$\delta_2 = S_2 - S_0.$$

If the angles are not small, these amplitudes should be reduced to circular measure by means of the known distance of the scale from the mirror.

Several values of the ratio of damping should be obtained in the following manner: Suppose the $(n + 1)$ st amplitude to be about one third of the first; λ should then be determined from the ratios

$$\frac{\delta_1}{\delta_{n+1}}, \frac{\delta_2}{\delta_{n+2}} \dots$$

Determine in this way the logarithmic decrement when the galvanometer coils are short-circuited, and are in open circuit, and also for several different resistances, in series with the galvanometer as follows: 20,000, 15,000, 10,000, 7,000, 5,000, 3,000, 1,000, 500, 200, and 100 ohms. Finally, from these determinations plot a curve, with box resistances as abscissas and corresponding values of the decrement as ordinates.

This curve will have an asymptote parallel to the axis of abscissas, at a distance from that axis equal to the decrement on open circuit. If the axis of abscissas be made to coincide with this asymptote, the ordinates to the curve will be the decrements due solely to induced currents. These decrements are inversely proportional to the resistance of the circuit. From this relation and from the curve, compute the resistance of the galvanometer.

EXPERIMENT U₃. Comparison of the capacities of two condensers.

I.

Ballistic galvanometer method.

When the coatings of a condenser are charged to a potential difference pd , the charge or quantity of electricity stored in the condenser is

$$Q = Cpd, \quad (327)$$

in which C is the capacity of the condenser. It has already been shown in preceding experiments that if the quantity of electricity Q is discharged through a ballistic galvanometer producing the deflection δ , we have

$$Q = Q_0(1 + \frac{1}{2}\lambda)\delta. \quad (328)$$

If a condenser of capacity C_1 , charged to a potential difference pd_1 be discharged through the ballistic galvanometer, we have

$$C_1 = \frac{Q_0}{pd_1}(1 + \frac{1}{2}\lambda)\delta_1. \quad (329)$$

If another condenser of capacity C_2 , charged to a potential difference ρd_2 , be discharged through the *same* ballistic galvanometer, we shall have a similar relation. And if the first equation be divided by the second, we shall have

$$\frac{C_1}{C_2} = \frac{\rho d_2 \delta_1}{\rho d_1 \delta_2}. \quad (330)$$

A still simpler relation follows if the condensers have been charged to the same potential difference.

The procedure in this experiment is as follows :

(1) Connect the condenser* in series with the battery and ballistic galvanometer, and place in the circuit a double contact key, as shown in Fig. 117.

(2) Make contact at *A*, and thus charge the condenser through the galvanometer. The corresponding galvanometer throw should be determined as in Exp. U₂.

(3) Break contact at *A*, and immediately make contact at *B*, thus discharging the condenser through the galvanometer. The galvanometer needle will receive an impulse in the opposite direction, which should be very nearly equal to the former throw. These observations should be repeated several times in order to get a good average.

A similar series of observations should now be taken with the condenser replaced by the one with which it is to be compared. If the capacities of the two condensers do not differ greatly, that is, if one is not more than two or three times as great as the other, the same number of cells should be used. If the difference of capacity is very large, the E. M. F.'s of the batteries in the two cases should be adjusted to suit the two condensers.

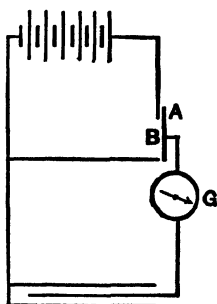

Fig. 117.

* In condenser work it is necessary to use great care in securing good insulation, because the condenser must sometimes remain charged for a few minutes while unconnected with a battery.

When condensers are connected as shown in Fig. 118, they are said to be connected in multiple. If C is the capacity in multiple, we have the relation

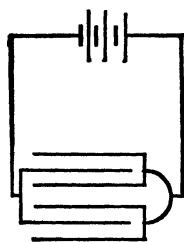

Fig. 118.

$$C_m = C_1 + C_2 + \dots \quad (331)$$

When condensers are connected as shown in Fig. 119, they are said to be connected in

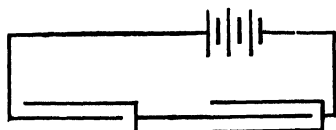

Fig. 119.

series. If C_s is the capacity of the system in series, we have

$$\frac{1}{C_s} = \frac{1}{C_1} + \frac{1}{C_2} + \dots \quad (332)$$

This relation may be readily derived by making use of the following facts :

(1) The potential difference at the terminals is equal to the sum of the potential differences between the coatings of each condenser, or

$$pd_s = pd_1 + pd_2 + \dots \quad (333)$$

(2) When several condensers are connected in series, the quantity of electricity on each coating of every condenser is the same, or

$$Q_1 = Q_2 = \dots \quad (334)$$

Equation 332 then follows directly from the definition of capacity. It is also to be remembered that the capacity of a system of condensers connected in series is the ratio of the charge on either extreme coating divided by the potential difference between the extreme coatings.

The relations expressed in equations 331 and 332 should be verified experimentally. This may be done as above by comparing the series or multiple system with a condenser whose capacity is known.

The following observations are to be made :

Three readings of the throw of the ballistic galvanometer are

to be made for both charging and discharging a condenser of known capacity. To eliminate errors due to lack of symmetry of galvanometer throws on the two sides of the rest position, reverse the switch leading to the galvanometer and repeat the readings as noted above.

In a similar manner make sets of readings for each of the unknown condensers and also when the unknowns are in multiple and in series. Compare the capacities of the measured multiple and series groupings with their computed values, based on the individual determinations.

Addenda to the report :

(1) Give a physical definition of capacity, of unit capacity, and explain upon what the capacity of a condenser depends.

(2) Derive expressions for the capacity of a number of condensers in series and in multiple.

(3) Show that the expression for the capacity of a simple plate condenser is

$$C = \frac{kA}{4\pi d}.$$

II.

Bridge method.

The method outlined below may be applied to comparison of capacities of condensers whose times of charge and discharge are very small. It will not apply where there is absorption, or much electromagnetic induction, such as in cables.

Build a Wheatstone bridge, using two resistance boxes R_1 and R_2 , two condensers C_1 and C_2 to be compared, a ballistic galvanometer G , a battery B , and a key K . The use of the key is to charge and discharge the condensers.

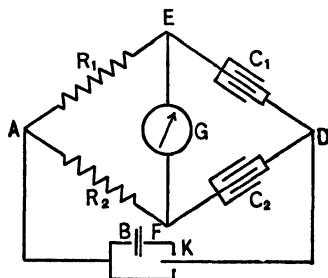

Fig. 120.

The resistances R_1 and R_2 must have no self-induction.

When the proper values of the resistances have been chosen, the bridge will be balanced, and there will be no throw of the galvanometer either on charging or discharging, there being no difference of potential existing between the points E and F .

In order that there be no ρd between E and F the following relation must hold :

$$\frac{C_1}{C_2} = \frac{R_2}{R_1}. \quad (335)$$

If no charge flows through the galvanometer, all the quantity passing to one set of plates for condenser C_1 must pass through the resistance R_1 , and the electricity charging one set of plates of C_2 must pass through the resistance R_2 . The transfer of the two quantities of electricity must take place in the same time interval.

The experiment may also be performed by substituting for the ballistic galvanometer a telephone receiver, and for the battery the secondary of an induction coil or an alternating E. M. F. If the lighting circuit is used as a source of alternating E. M. F., a protecting resistance should be placed in series with it.

Put a standard condenser of known capacity in one arm of the bridge and the condenser whose capacity is to be determined in another arm as shown in the diagram. Adjust the resistances until the detector indicates no charge passing between E and F . Read the resistances. Do not use a resistance of less than 500 ohms in either box. Vary one resistance by a few hundred ohms and proceed as before. Make five such determinations for each of the unknowns and also for the unknowns when they are in series, and in multiple.

Compare the capacities of the measured multiple and series groupings with their computed values, based on the separate determinations.

Addenda to the report :

Answer the addenda to part I and prove that for method II

$$\frac{C_1}{C_2} = \frac{R_2}{R_1}.$$

EXPERIMENT U₄. Measurement of the capacity of a condenser in absolute measure.

If the condenser is charged or discharged through a ballistic galvanometer, we shall have, as in the preceding experiment,

$$C = \frac{Q_0}{pd} \left(1 + \frac{1}{2} \lambda \right) \delta. \quad (336)$$

If the quantities on the right of this equation are all determined in absolute measure, the capacity will be determined independently of the capacity of any standard condenser. The constants Q_0 , pd , and λ should be determined as described in previous experiments. It should be remembered that the value of λ to be used in this experiment is that obtained when the galvanometer circuit is open.

The procedure is as follows :

(1) The throw of the needle δ is to be determined, as in the preceding experiment, by charging and discharging the condenser through the galvanometer.

(2) The values of δ , which always differ in the case of the charge and of the discharge, respectively, should be averaged separately. The former value will correspond to the instantaneous capacity, while the latter corresponds to the capacity of the condenser after a greater or less absorption has taken place.

Determine the capacities of three condensers separately, in series and in multiple, making observations in the manner indicated in Exp. U₃ I.

Answer the addenda of U₃ I.

CHAPTER XIII.

GROUP V : ELECTROMAGNETIC INDUCTION.

(V) *General statements ; (V₁) Dip and intensity of the earth's magnetic field (method of the earth inductor) ; (V₂) Lines of force of a permanent magnet ; (V₃) Mutual induction ; (V₄) Self-induction.*

(V) **General statements concerning induction.**

Faraday discovered that when any portion of a complete circuit is moved through a magnetic field, an electric current circulates in all parts of it.

This fact may be viewed as follows :

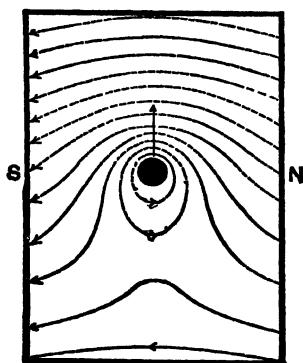

Fig. 121.

Let there be a conductor, shown in cross-section (Fig. 121), which forms part of a complete circuit. Suppose it to be moving in the direction of the arrow in a magnetic field originally uniform. The arrangement of the lines of force of this field is indicated by the dotted lines. During the motion of this conductor the otherwise uniform field will be distorted. The field of force on the side *towards* which the conductor is moving will

be stronger than before, and the lines of force will be crowded together, and concave towards the conductor. On the opposite side, the lines of force will be more widely separated, and convex towards the conductor. Immediately around the conductor, and extending to a greater or less distance, according to the intensity of the induced current, the lines of force will be closed curves surrounding it. The positive direction of the lines.

of force in these closed curves are as indicated in the figure. It follows that if the direction of motion is to the right, and the positive direction of the lines of force vertically upward, the current will be directed towards the observer. Or if the motion is along the x -axis, and the lines of force along the z -axis, the current will be directed along the y -axis, each in the positive direction. (See Fig. 122.)

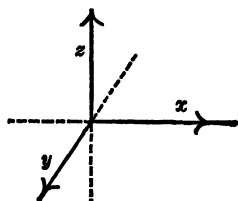

Fig. 122.

Since a current may be produced in this way, it must be that there is an E. M. F. generated in the moving conductor. This E. M. F. exists whether the circuit is closed or not. In the latter case, if the motion is uniform and in a uniform field, there will simply be a static rise of potential along the conductor in the direction in which current would flow if the circuit were completed.

It has been experimentally demonstrated that the E. M. F. generated in this way is directly proportional :

- (1) To the velocity of motion.
- (2) To the intensity of the magnetic field.
- (3) To the length of the moving conductor ; the three directions being mutually perpendicular.

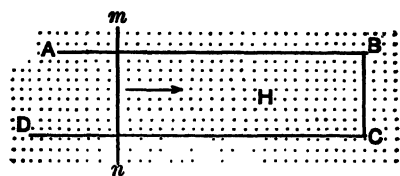

Fig. 123.

Let $ABCD$ (Fig. 123) be a rectangular circuit with one open side, and let it be placed in a magnetic field of intensity H , the lines of force being supposed perpendicular to the plane of the paper. Let mn be a conductor resting on the two parallel conductors and completing the circuit. If the length of BC is l , and mn moves in the direction of the arrow with a velocity $V = \frac{dx}{dt}$, the E. M. F. generated in the circuit will be, in volts,

$$E = \frac{1}{10^8} H \frac{dx}{dt} l. \quad (337)$$

* For the significance of the numerical factor 10^8 see introduction to group S, p. 269.

When different parts of a circuit cut lines of force at different rates, the total E. M. F. generated in the whole circuit is

$$E = \frac{1}{10^8} H \int \frac{dx}{dt} dl. \quad (338)$$

It is obvious that E may be zero both when no lines of force are cut, also when the E. M. F.'s in different parts of the circuit

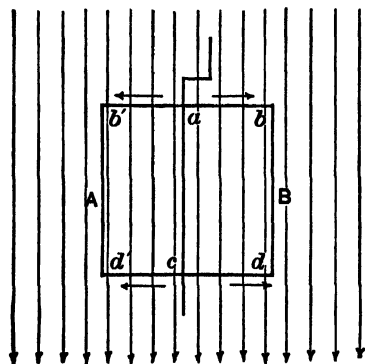

Fig. 124.

due to cutting lines of force are oppositely directed, and exactly balance each other. For example, let AB , Fig. 124, be a rectangular circuit whose plane is parallel to the lines of force, and capable of rotation about an axis parallel to the lines of force. If this circuit be rotated clockwise, E. M. F.'s will be generated in the different parts, as indicated by the arrows. These obviously annul each other when added around the complete circuit. There is, however, an E. M. F. between a and b producing a rise of potential from a to b , from a to b' , from c to d , and from c to d' .

The equation for the E. M. F. generated in a complete circuit may often be simplified in the following manner: Let N be the total number of lines of force that at any instant pass through the circuit. Now if the position of the circuit is changed in the time dt in such a manner that the change in the number of lines of force that pass through the circuit is dN , we have, for the complete circuit,

$$E = \frac{1}{10^8} \frac{dN}{dt}. \quad (339)$$

If the circuit is composed of n turns, through each of which the N lines pass, we have

$$E = \frac{n}{10^8} \frac{dN}{dt}. \quad (340)$$

Furthermore, since $Q = \int Idt$, we have, for the total quantity of electricity produced,

$$Q = \frac{I N_1}{10^8 R}, \quad (341)$$

in which N_1 is the number of lines of force cut, and R is the resistance of the circuit in ohms. Q depends not at all on the length of the cutting lines of force, but only on the total number of lines cut.

In making application of the law of induced E. M. F., the following fundamental principles are of service:

(1) The source of the magnetic field is immaterial. It may be due to a permanent magnet, to the earth, or to an electric current.

(2) It is immaterial whether the conductor is moved in a magnetic field, or a magnetic field is moved past the conductor.

(3) Movements of the lines of a magnetic field may be produced in two ways:

(a) By moving bodily a magnet, or a circuit conveying a current.

(b) By causing a current to change, in which case its lines of force will move outwards when the current increases, or move inwards and disappear when the current decreases.

(4) An E. M. F. may be induced in a conductor already conveying a current, and this may either increase or decrease the current flowing.

(5) If the current flowing in a circuit is decreased, the magnetic field due to the current will decrease, the lines of force collapsing on the conductor. This motion of the field will produce an E. M. F. in the conductor tending to produce a current in the *same* direction as the original current. If the current is increased, the induced E. M. F. changes sign. From this it follows that when current is changed in a circuit, an induced

* The factor N_1 takes into consideration the number of turns n as well as the change in the magnetic field.

E. M. F. is set up, which opposes that change. This kind of induction is called self-induction.

EXPERIMENT V₁. Dip and intensity of the earth's magnetic field. (Method of the earth inductor.)

The earth inductor consists essentially of a coil of wire *C*, Fig. 125, capable of revolution about an axis *A* in its own plane.

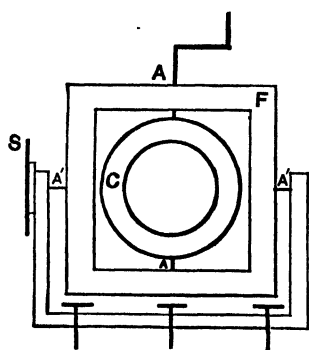

Fig. 125.

Usually this coil is mounted in a frame *F*, which is itself capable of rotation about an axis *A'* in its plane, perpendicular to the axis *A*. To this frame is attached a graduated circle *S*; by means of this circle the angle which the axis *A* makes with a horizontal plane can be measured. The instrument is also furnished with stops, which enable the coil to be turned through exactly 180°; and the base

is furnished with leveling screws, by means of which the plane containing the two axes of revolution may be made truly horizontal.

I.

To determine the angle of dip.

The angle of dip is defined as the angle which the direction of the lines of force makes with the horizon. If *H* and *V* are the horizontal and vertical components of the intensity of the earth's field at any point, we have

$$\tan \beta = \frac{H}{V}. \quad (342)$$

To determine β , which is the object of this part of the experiment, proceed as follows:

(1) Turn the whole apparatus until the axis about which the square frame revolves is perpendicular to the magnetic meridian. This may be done with the aid of a small compass.

(2) Adjust the leveling screws until the square frame containing the two axes of revolution is truly horizontal.

(3) Adjust the stops so that the plane of the movable coil is horizontal in both of the extreme positions.

When thus adjusted, the vertical component of the magnetic field passes through the coil. In other words, V lines of force per square centimeter pass through the coil. If n is the number of turns of the coil, and A is the mean area of the coil, the number of lines of force passing through the coil will be nAV .

(4) If the coil be now turned through 180° , all the lines of force will be cut twice, and we have from equation 341

$$Q_v = \frac{2nAV}{10^8 R}, \quad (343)$$

in which R is the resistance of the circuit. If a ballistic galvanometer forms part of the circuit, and if the coil be turned quickly, we shall have

$$Q_v = Q_0 \left(1 + \frac{1}{2} \lambda\right) \delta_v = \frac{2nAV}{10^8 R}, \quad (344)$$

in which δ_v is the throw of the galvanometer needle. If a tangent galvanometer be employed and the angular motion of the needle is not small, $\sin \frac{1}{2} \delta$ must be used instead of δ .

(5) If the square frame be now rotated through exactly 90° , as measured by the divided circle, the number of lines of force passing through the coil in its new position will be nAH ; and if δ_H is the corresponding galvanometer throw, we have

$$\frac{\delta_v}{\delta_H} = \frac{V}{H}. \quad (345)$$

The constants n , A , R , Q_0 , and λ , being the same for both positions, are eliminated, and it is not necessary to know their values.

The values δ_v and δ_H used in this computation should each be the mean of ten or twelve determinations.

When the square frame makes an angle with the horizontal

equal to the dip, no lines of force thread through the coil in any position; consequently, no current will be produced when it is rotated about its own axis. The position in which no current is produced by the rotation of the coil should be found by trial. The angle through which the frame was turned from the horizontal position furnishes a second determination of the dip.

II.

To determine intensity.

From equation 343 it is obvious that both the vertical and horizontal intensity may be determined in absolute measure, provided Q_0 and λ have previously been determined for the ballistic galvanometer, and n , A , and R are known.

The lines of force make but a small angle with the vertical, and on this account a small error in leveling the coil will produce a relatively great error in the determination of H . This should be remembered in determining the dip as well as in determining the horizontal intensity.

Addenda to the report:

(1) Explain fully the *direction* of the induced current when the coil is rotated about a vertical and a horizontal axis.

(2) Explain from first principles why there is no current when the coil is rotated about an axis parallel to the lines of force.

EXPERIMENT V_2 . Measurement of the lines of force of a permanent magnet.

The object of this experiment is the determination of the number of lines of force that emerge from the positive half of a permanent magnet. Before beginning these measurements the constant and the logarithmic decrement of a ballistic galvanometer must have been determined (Exps. U_1 and U_2). These values having been ascertained, the procedure is as follows:

Connect a test coil of a known number of turns in series with a variable known resistance and a ballistic galvanometer.

Place the coil at the center of the magnet, and when the galvanometer needle has come to rest, observe the throw of the needle produced by quickly slipping the test coil off the end of the magnet. This test coil should consist of a considerable number of turns of small copper wire, Nos. 24-36, according to the resistance of the galvanometer and the sensitiveness of the latter. It should be of such a form as to fit easily over the bar magnet to be tested. (See Fig. 126.)

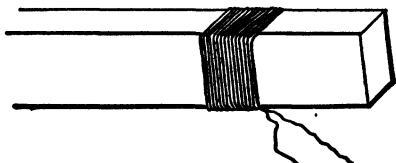

Fig. 126.

Place the coil again at the center of the magnet and move it stepwise a centimeter at a time to the end of the magnet; then remove it entirely, observing throws of the ballistic galvanometer for each change of position.

Make three sets of readings in this manner from the center of the magnet to each end.

Plot a curve, using distances from the center of the magnet to the mid-point of each space as abscissas and mean throws as ordinates, paying due regard to signs.

Plot another curve on the same sheet to the same scale, using distances as abscissas as before, but using the corresponding sum of the throws as ordinates.

Discuss the results and curves.

If N is the number of lines of force that emerge from the magnet, and n the number of turns in the coil, we have, from equations 324 and 341,

$$Q = \frac{Nn}{10^8 R} = Q_0 \left(1 + \frac{1}{2} \lambda\right) \delta, \quad (346)$$

in which R is the resistance of the circuit.

The most suitable number of turns for the test coil will depend upon the strength of the magnet, the sensitiveness of the galvanometer, and the resistance of the circuit. These quantities should be so adjusted that the galvanometer throw is rather large. Within certain limits this result can be most

easily obtained by varying the resistance in circuit with the galvanometer.

If the bar is not symmetrically magnetized, the magnetic center must be found experimentally. To do this, move the test coil along the bar stepwise. When the magnetic center is reached, a slight motion of the coil in either direction may be made without producing a reversal of current in the galvanometer circuit.

By this method the flow of induction from several magnets should be determined, selecting for the purpose both bar magnets and those of the horseshoe type.

Addenda to the report :

(1) From the readings obtained compute the induction per square centimeter through the center of each magnet.

(2) If the magnetic moment is known, compute the distance between the poles, or, more properly, the distance between the "centers of gravity" of the two distributions of magnetism.

EXPERIMENT V₃. Mutual induction.

The objects of this experiment are : I, to observe certain of the phenomena of mutual induction ; II, to measure the quantity of electricity which circulates in a secondary circuit when the magnetic field in its vicinity produced by a current in a primary circuit is varied.

I.

The primary and secondary circuits consist of two coils of the same size. The primary coil, however, is wound with considerably coarser wire than the secondary coil.

The method is as follows :

(1) Connect the primary coil P (Fig. 127) in circuit with a battery of constant E. M. F., a variable resistance R and an ammeter or galvanometer suitable for measuring currents of about an ampere, and insert a make and break key K .

(2) Connect the secondary coil S in series with a ballistic galvanometer and a resistance box. The latter is placed in the

circuit to enable the observer to adjust the throws of the galvanometer needle.

(3) Place the primary and secondary coils close together, with their axes coincident.

(4) Observe the galvanometer throws when a current of about one ampere is made and broken in the primary circuit.

(5) The circuit being closed, the current flowing steadily in the primary circuit, observe the galvanometer throws produced by quickly moving the secondary to a distance of a meter; also when the coil is quickly replaced.

(6) Repeat these observations, this time moving the primary instead of the secondary coil.

(7) Observe the galvanometer throw when one of the coils is quickly turned and placed with its opposite face next to the other coil.

(8) Observe the effect upon the galvanometer when a permanent magnet is moved in the vicinity of the secondary coil.

Repeat all the above as a check.

II.

(A) The quantity of electricity which is produced in the secondary circuit is directly proportional to the intensity of the current that is made and broken in the primary circuit. To prove this relationship, use the following method :

(1) Make connections as in I, Fig. 127, the secondary coil being close to the primary with the axes coincident.

(2) Observe the throws of the ballistic galvanometer needle when the primary circuit is made and broken, the current being about 0.1 ampere.

(3) Note the current flowing in the primary circuit.

Repeat these observations with different currents in the

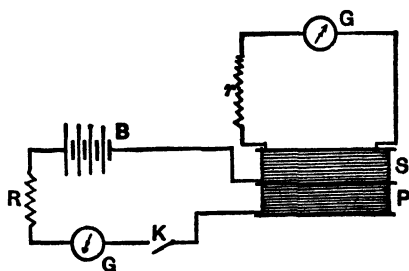

Fig. 127.

primary circuit ranging from 0.1 to 1.0 ampere, varying the current each time about 0.1 ampere.

The resistances of the two circuits should be so adjusted that for the maximum current used the throws on the ballistic galvanometer may be the largest that the scale will allow. The resistance of the secondary circuit must not be changed during the experiment.

If currents in the primary be plotted as abscissas, and throws of the ballistic galvanometer as ordinates, the resulting curve will be found to be a straight line passing through the origin. This verifies the relation

$$Q_s \propto I_p, \quad (347)$$

in which I_p is the current in the primary, and Q_s is the quantity of electricity which circulates in the secondary.

The apparatus described above should be further utilized to establish the following relations :

(B) The quantity of electricity which is induced in the secondary circuit is inversely proportional to the resistance of that circuit.

To determine this fact, the same connections as in (A) should be made. Now observe the throws of the ballistic galvanometer when the primary circuit, in which about 1.0 ampere is flowing, is made and broken, for several different resistances in the secondary circuit. The resistances should vary by ten equal steps from the smallest that will keep the throw just on the scale to a resistance which will cut down the throw to about one tenth of the maximum. Judgment should be used in selecting convenient values of resistances. If a curve be plotted with resistances in the secondary circuit as abscissas, and the reciprocals of throws as ordinates, it will be found to be a straight line; thus verifying the relation

$$Q \propto \frac{1}{R_s}. \quad (348)$$

If the results of (A) and (B) be combined, we have

$$Q_s = M \frac{I_p}{R_s}, \quad (349)$$

in which the constant M is defined as the coefficient of mutual induction of the two coils. The value of M depends solely on the construction of the two coils and their relative position. If Q , I , and R be measured in coulombs, amperes, and ohms, respectively, M will be expressed in henrys.

(C) If the distance between the primary and secondary coils be varied, the mutual induction will also vary. The relation between these two quantities may be experimentally determined as follows: Make connections as above, place the two coils on a common axis, and observe the throws of the ballistic galvanometer needle corresponding to several different distances between the two coils. From (349) we have

$$M = \frac{Q_s R_s}{I_p}. \quad (350)$$

If the current which flows in the primary while that circuit is closed has a constant value throughout the experiment, the mutual induction will be proportional to the product of resistance in the secondary circuit and the throw of the galvanometer needle, and we may write

$$M \propto \delta R_s. \quad (351)$$

These observations should be repeated with a soft iron core in the primary coil. In both cases use the same current in the primary, about 1.0 ampere. Take readings for ten different distances between the frames on which the coils are wound as follows: 0, 1, 2, 3, 5, 7, 10, 15, 20, 30, and 50 centimeters. In each case use such a resistance in the secondary as will give approximately the same maximum readable throw.

Plot two curves, one for each case, on the same sheet, to the same scale, using the same origin, with distances in centimeters as abscissas and corresponding throws as ordinates.

Compute five values of the product δR , for similarly located points on each curve.

If the coefficient of mutual induction is known for any one position, it can now be computed for any other position by a simple proportion between the known and unknown coefficients, and the corresponding ordinates to the curves.

EXPERIMENT V₄. Self-induction.

In a circuit containing a generator, a key, and coil of wire, when the key is closed, the E. M. F. causes a current to flow, and about the wire a magnetic field is set up, the lines of force being closed curves. These lines may be thought of as spreading out from the wire as the current grows, taking up their final positions with respect to the wire when the current reaches its full value. As they are spreading out, especially in the coil, they will cut across other parts of the circuit, and therefore in those parts an E. M. F. will be generated which opposes the setting up of the current in the circuit of which the coil is a part. If, after the current has been established, the generator be cut out of the circuit, the current will drop to zero; but on account of the lines of force of the collapsing field cutting across the circuit itself, an E. M. F. is set up which opposes the stopping of the current. This phenomenon is called self-induction.

The E. M. F. of self-induction of any coil depends upon the rate of cutting of lines of force. (See equation 337.) The rate of cutting depends upon the number of turns, the area of the coil, and the rate of change of the current. The E. M. F. may be expressed as

$$E = -dN/dt = -L \frac{dI}{dt}, \quad (352)$$

in which dI/dt is the rate of change of the current and L a constant for the given coil called the coefficient of self-induction of that coil.

The physical meaning of L may be obtained in two ways:

First, from the equation above, L is equal to the E. M. F. produced when the rate of change of the current is unity. Second, if the equation

$$dN/dt = L \frac{dI}{dt}$$

be integrated,

$$N = LI. \quad (353)$$

If this integration be made between the limits of 0 and 1 for the current, then $I = 1$ and $N = L$, that is, the coefficient of self-induction of a coil is equal to the number of lines of force cut when the current is changed by unit amount.

The introduction to the V group should be carefully studied, for to successfully perform the following experiments it is necessary to understand the theory of induced electromotive forces. It is necessary to use much care, patience, and judgment in order to choose the proper conditions, to eliminate or neutralize thermo-currents, and to get good steady current balances, since the methods are based on the Wheatstone bridge.

I.

Measurement of self-induction by comparison, using a variable standard self-induction.

The connections to be made are those of a Wheatstone bridge, Fig. 128, in which R_1 and R_2 are non-inductive resistances used as ratio arms, L_x the unknown inductive resistance whose resistance is R_3 , L_s the standard variable self-induction of resistance R_4 , B the battery, and G the galvanometer. S, S are commutators for reversing the direction

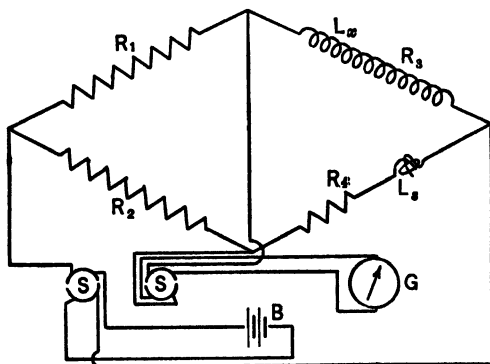

Fig. 128.

of the current from the battery through the system, excepting the galvanometer. The galvanometer is so connected that the impulses due to the *extra* current are in the same direction and additive. The system is first balanced in the ordinary manner of the bridge for steady currents. After this balance is obtained, the commutators are revolved, in general producing a deflection of the galvanometer due to the currents of self-induction. The variable self-induction is now changed until no deflection is noted either for steady or variable currents, if such a double balance be possible. In such an event the E. M. F.'s of self-induction oppose each other in such ratio that no current flows through the galvanometer. In this case

$$\begin{aligned} L_x/L_s &= R_1/R_2, \\ L_x &= L_s(R_1/R_2). \end{aligned} \quad (354)$$

In the actual operation of the experiment it may happen that the range of the standard self-induction is not such as to make it possible to get the ratio of the self-inductions to be equal to that of the resistances. In such a case it is necessary to put in series with the standard self-induction or with the inductance to be determined a non-inductive resistance R , get a new steady current balance, and try again. If the balance for variable currents is a very small reading on the standard so that the error in setting is large compared with the actual reading, it is best to change the steady current balance by means of auxiliary resistances in one or the other of the inductance arms in order to get a greater reading on the standard.

The connections having been made as indicated in Fig. 128, get a steady current balance. Then change the value of the standard until for varying currents no deflection of the galvanometer is obtained. If a balance cannot be obtained for variable currents, then insert a non-inductive resistance in series with the standard, putting in such a resistance to change the ratio of the bridge arm by 50 per cent, and try again. This trial will indicate what changes must be made to get both steady and variable current balances.

Make three determinations of the unknown inductance, using different ratios. Vary the ratio of the arms within allowable limits.

NOTE. The proof of equation 354 is based on the fact that the galvanometer and battery branches of the circuit are conjugate, and consequently an auxiliary E. M. F. in an arm of the bridge will produce the same current through the galvanometer branch whether the battery circuit is closed or open. Therefore we may write the equations for the currents through the galvanometer due to induced E. M. F.'s in arms R_3 and R_4 as if the battery branch were open.

$$I_G = I_4(R_1 + R_2) / (R_1 + R_2 + R_G) \quad (355)$$

and

$$I_4 = \frac{L_s di_4 / dt}{R_4 + R_3 + (R_1 + R_2) R_G / (R_1 + R_2 + R_G)}. \quad (356)$$

Substituting for I_4 its value,

$$I_G dt = \frac{L_s di_4 (R_1 + R_2 + R_G) (R_1 + R_2)}{[(R_1 + R_2 + R_G) (R_4 + R_3) + (R_1 + R_2) R_G] (R_1 + R_2 + R_G)}. \quad (357)$$

Integrating (357), the quantity through the galvanometer due to the induced E. M. F. in branch 4 is shown to be

$$Q_s = L_s i_4 (R_1 + R_2) / [(R_1 + R_2 + R_G) (R_4 + R_3) + (R_1 + R_2) R_G], \quad (358)$$

and in like manner that due to L_x is

$$Q_x = L_x i_3 (R_1 + R_2) / [(R_1 + R_2 + R_G) (R_4 + R_3) + (R_1 + R_2) R_G]. \quad (359)$$

When a balance is obtained for variable currents as well as steady currents, $Q_s = Q_x$ and $L_s i_4 = L_x i_3$, or $L_s / R_4 = L_x / R_3$, since $i_4 = \rho d / R_4$ and $i_3 = \rho d / R_3$ for steady currents.

$$\begin{aligned} \text{but} \quad & L_x / L_s = R_3 / R_4, \\ & R_3 / R_4 = R_1 / R_2, \\ & \therefore L_x = L_s R_1 / R_2. \end{aligned} \quad (360)$$

II.

Measurement of self-induction by comparison with a capacity (Rimington's modification of Maxwell's method).

A Wheatstone bridge is arranged with the inductance to be determined in one arm of the bridge (Fig. 129). In the

same arm is also placed a variable non-inductive resistance, the use of which is noted below. The other arms of the bridge are made up of non-inductive resistances. A condenser of known capacity is arranged

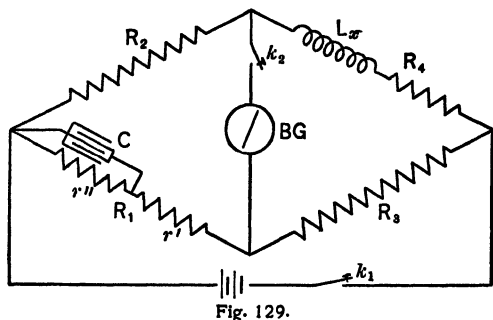

Fig. 129.

so that it may be shunted about various resistances in branch R_1 , while keeping the resistance constant. This is done in the experiment as here performed by using two resistance boxes r'

and r'' , so shifting their values as to keep their sum R_1 constant.

The bridge is balanced in the usual manner for steady currents, being careful to close the battery branch key before that in the galvanometer branch. Then the resistance around which the condenser is shunted is varied until no kick of the galvanometer is noted when the galvanometer key is closed before the battery key. When this condition is obtained,

$$L_x = Cr'^2 R_4 / R_1, \quad (361)$$

in which C is the capacity of the condenser in farads, r'' the resistance about which the capacity is shunted, R_4 the total resistance of the arm in which the self-induction is placed. The galvanometer used should be quite sensitive.

In one arm of the bridge, R_3 say, put a wire in series with the box by means of which, by varying the length of the portion of the wire used, an accurate steady current balance may be obtained. Two boxes of 1000 ohms each may be used in the arm R_1 . Pull out all of the plugs of one of these boxes and connect the condenser (0.5 or 1 m. f.) across its terminals. A box having adjustable side plugs may be substituted for r' and r'' . Balance the bridge for steady currents. When this is obtained a kick of the galvanometer will, in general, be produced

by closing the galvanometer key and then the battery key. Change the value of r'' around which C is connected, keeping $r' + r''$ constant, until no kick is observed, if this be possible. If such a balance cannot be obtained, add non-inductive resistance to branch R_4 (50 ohms or more) and try again. Continue the preliminary adjustments until changes of r'' and r' will produce deflections in opposite directions. Then get a steady current balance, after which change r'' and r' , keeping their sum constant, until no deflection is obtained, no matter in what order the keys are closed. From the ordinary law of the bridge R_4 may be computed, after which L_x may be determined from the equation given above.

Make three determinations of L_x , using two different capacities, and then a new value of the non-inductive resistance in series with the unknown inductance.

Since the bridge is balanced for steady currents, the galvanometer and battery branches are conjugate, and the current through the galvanometer due to an E. M. F. in any branch will not depend on the resistance or E. M. F. of the battery branch. Equations may be written for the current through the galvanometer branch as if the battery branch were open, as indeed it is, on breaking the circuit.

Instead of the instantaneous value of the current the total quantity of electricity passing through the galvanometer may be written. That quantity discharged through the galvanometer due to the inductance is

$$Q_L = \frac{L_x i_4 (R_1 + R_2)}{(R_1 + R_2 + R_G)(R_3 + R_4) + (R_1 + R_2)R_G}; \quad (362)$$

and that quantity due to the discharge of the condenser in which the quantity $C r'' i_1$ is stored is

$$Q_C = \frac{C r'' i_1 r'' (R_3 + R_4)}{(R_3 + R_4 + R_G)(R_1 + R_2) + (R_3 + R_4)R_G}. \quad (363)$$

If no throw of the galvanometer takes place, $Q_L = Q_C$. Putting the right-hand members of the equations equal, remembering

that $R_1/R_2 = R_3/R_4$, and that $i_1/i_4 = R_4/R_3$, and simplifying, we have

$$L_s = Cr'^2 R_4/R_1.$$

III.

*Measurement of self-induction by comparison with a capacity (Anderson's method).**

This modification of Maxwell's method of measuring self-induction is very useful and accurate for finding small inductances. The circuit is made up in the Wheatstone bridge form (Fig. 130), with the unknown inductance L in one arm of the bridge; the other arms, R_1 , R_2 , and R_3 , being non-inductive resistances. In series with the galvanometer, which is placed in its usual position, there is inserted a variable non-inductive resistance r connecting it to the point b of the bridge. A capacity C is inserted between the point a and the point f (between the resistance r and the galvanometer G). A buzzer is put in the battery branch, in multiple with the key k_2 , to produce a variable current when the key is opened and the buzzer armature given a start. To detect the presence of the variable current in the branch fd , a telephone T is placed in multiple with the galvanometer, the key k_1 making it possible to insert either the galvanometer or the telephone.

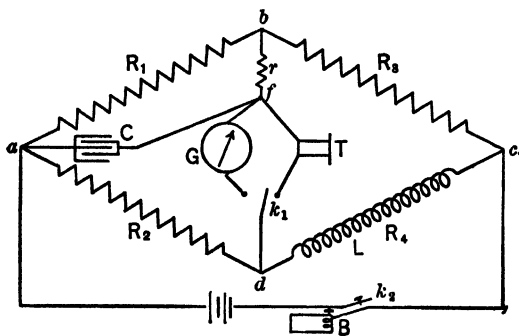

Fig. 130.

The bridge is balanced in the usual manner for steady cur-

* Anderson, Phil. Mag., S. 5, vol. 31, 1891, p. 333; Fleming, Phil. Mag., S. 6, vol. 7, 1904, p. 586.

rents, using the galvanometer. The buzzer is then set in operation, and the value of r changed until the sound heard in the telephone reaches a minimum. The resistance r in no way affects the steady current balance, no matter what changes are made in its value. The two balances being obtained, the value of L may be computed from the equation

$$L = C \{r(R_2 + R_4) + R_2 R_3\}. \quad (364)$$

It may be shown from this equation that in order to get a balance for variable currents, the product $CR_2 R_3$ must be less than L , otherwise r would have to be a negative resistance, manifestly an absurdity. If, a steady current balance having been obtained, it is impossible to get a balance for variable currents, the product $CR_2 R_3$ must be increased. It is to be noted that this may be attained by increasing the capacity alone, which will not destroy the steady current balance. If R_2 or R_3 is increased, a *new* steady current balance must be obtained before trying again for a variable current balance. It has been shown also that the best results are obtained when the resistances R_1 and R_2 are comparatively large, and R_3 and r are small.

In performing the experiment, make three independent determinations of the value of the inductance of the unknown, varying any or all the factors. The following is an outline of the derivation of equation 364.

When the bridge is balanced for both constant and variable currents, the ρd between f and d is zero.

Let q_1 , q_2 , q_3 , and q_r be the quantities of electricity that have flowed through the resistances R_1 , R_2 , R_3 , and r , respectively, in the time t .

$$\text{Then} \quad q_1 + q_r = q_3, \quad (365)$$

$${}^* \rho d_3 = R_1 \frac{dq_1}{dt} = \frac{q_r}{C} + r \frac{dq_r}{dt}. \quad (366)$$

$${}^* \rho d_1 = \frac{q_r}{C} = R_2 \frac{dq_2}{dt}. \quad (367)$$

$$d\mathcal{P}d_o = r \frac{dq_r}{dt} + R_3 \frac{dq_3}{dt} = R_4 \frac{dq_2}{dt} + L \frac{d^2q_2}{dt^2}. \quad (368)$$

Substitution in (368) of the values of $\frac{d^2q_2}{dt^2}$, $\frac{dq_2}{dt}$, $\frac{dq_3}{dt}$, and $\frac{dq_1}{dt}$ obtained from (367), (365), and (366), respectively, gives

$$\frac{dq_r}{dt} \left(r + R_3 + \frac{rR_3}{R_1} - \frac{L}{CR_2} \right) = \frac{q_r}{C} \left(\frac{R_4}{R_2} - \frac{R_3}{R_1} \right). \quad (369)$$

But for a steady current balance the theory of the Wheatstone bridge shows that

$$\frac{R_4}{R_2} - \frac{R_3}{R_1} = 0. \quad (370)$$

Consequently the right-hand member of (369) must be zero, and since the variable current is not in general zero, its coefficient must be equal to zero.

$$\therefore r + R_3 + \frac{rR_3}{R_1} - \frac{L}{CR_2} = 0. \quad (371)$$

Solving (371) for L and remembering the relation given in (370),

$$L = C \{ r(R_2 + R_4) + R_2R_3 \}.$$

CHAPTER XIV.

GROUP W: MAGNETIC PROPERTIES OF IRON.

(W) *General statements;** (W₁) *Magnetometer method; (W₂)
Ring method, with ballistic galvanometer.*

(W) **General statements concerning the magnetization of iron.**

When a piece of iron in a neutral magnetic state is placed in a magnetic field, no matter how produced, it becomes magnetized and in general exhibits free poles. Within the iron there will be more magnetic lines than exist in the same space when the iron is not present, the additional lines being due to the iron being a magnet. Each unit positive pole will supply 4π lines, called *lines of magnetisation* to distinguish them from the lines of the magnetizing field. The total number of lines, including lines of force and lines of magnetization, is called the *magnetic induction*. The number of unit poles per unit of cross-section is called the *intensity of magnetisation*. The intensity of magnetization is also defined as the magnetic moment per unit of volume.

Let H be the strength of the magnetizing field, I_n the intensity of magnetization, B the magnetic induction per unit of area, ϕ the total induction, and A the area considered. Assuming the induction uniform, then

$$\phi = 4\pi m + HA. \quad (372)$$

The induction per unit area is

$$\frac{\phi}{A} = 4\pi \frac{m}{A} + H, \quad (373)$$

or
$$B = 4\pi I_n + H. \quad (374)$$

* See Introduction to Group Q.

If a piece of iron initially unmagnetized be subjected to a magnetic field which is increased with no breaks or reversals whatever, the ratio of the induction produced to the magnetizing field is called the *permeability*,

$$\frac{B}{H} = \mu; \tag{375}$$

and the ratio of the intensity of magnetization to the magnetizing field is called the *susceptibility*,

$$\frac{I_n}{H} = k. \tag{376}$$

Let the curve *oabc*, Fig. 131, represent the increase of *B* with *H*. Such a curve is called a magnetization curve. The

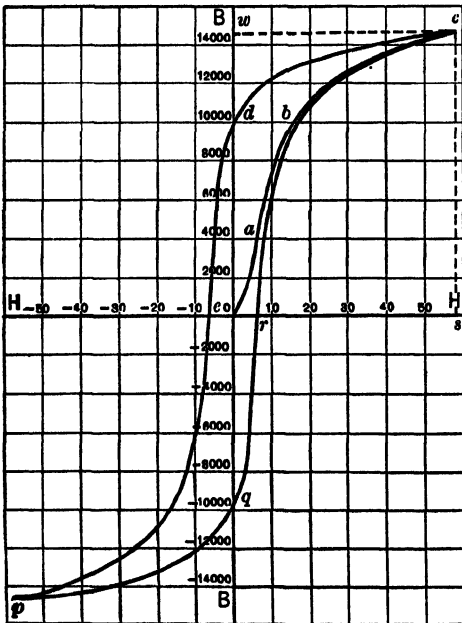

Fig. 131.

permeability μ applies only to the ratio of corresponding values of *B* and *H* used in obtaining this curve. If instead of *B* and *H* as co-ordinates, I_n and *H* be used, a curve of the same general shape may be drawn. However, when the iron becomes fully magnetized, I_n becomes constant, and the curve will then be parallel with the *x*-axis; while when *B* and *H* are plotted, *B* will continue to increase with

H even after the iron is fully magnetized.

If, after the iron has been magnetized, the magnetizing field be decreased to zero, it is found that the iron retains some of its magnetism. The curve *cd* may be taken to represent the

decrease of B as H is reduced to zero. The ordinate od' represents the residual magnetism. To demagnetize the iron completely requires the application of a magnetizing field in the opposite direction, as oe . The strength of this field is called the *coercive force*. If the field be further increased in the negative direction, the iron will become magnetized in the opposite sense, as indicated by the curve ep . Now let the negative field be decreased to zero and then increased in the original direction to its original maximum os , the iron will be demagnetized and remagnetized in the original sense as indicated by the curve $pqrc$. The initial and final values of B will not be the same, however, unless the cycle of magnetization has been repeated several times. In this case the shape and size of each succeeding loop will be the same. This means that the maximum values of B for the magnetization curve and the loop are different for the same maximum value of H , and that the magnetization curve and loop are to be plotted independently. The lagging of the magnetization behind the magnetizing force is called *magnetic hysteresis*, and the loop obtained by plotting B and H is called a hysteresis loop. Its area is proportional to the work done in carrying the iron through one complete cycle of magnetization.

The susceptibility and permeability of a given sample of iron vary with an increasing magnetizing field, being small for a very weak field, increasing very rapidly to a maximum as the field increases, and then decreasing to values smaller than the initial one. The maximum values are reached at comparatively weak fields. The relations between k , μ , and H are best shown graphically in susceptibility and permeability curves, using values of H for abscissas and corresponding values of k and μ for ordinates.

The intensity of magnetization is found to depend upon (1) the intensity of the magnetizing field, (2) the quality of the iron, and (3) the previous state of magnetization. When different samples of iron are to be compared, they should have no residual magnetism and should be subjected to magnetizing

fields that can be varied at will, progressively increasing or decreasing them.

Two methods of studying the magnetization of iron follow, one being a magnetometer method in which the field, at a magnetometer needle, produced by a rod of iron, is compared with a known field; the other being a method of measuring the changes of induction in an iron ring by the use of a ballistic galvanometer.

EXPERIMENT W₁. Magnetic properties of iron—magnetometer method.

The rod or wire of iron or steel whose magnetic properties are to be studied should have a length which is great compared with its diameter. This is desirable on account of the demagnetizing effect of its own poles. The residual magnetism is much greater for a long than a short bar of the same material of equal diameter, even after having been subjected to such magnetizing fields as to produce the same intensity of magnetization in each. The value of the magnetizing field with the iron in place must be corrected for the field due to the poles. According to Ewing, the value of the magnetizing field should be $H' = H - NI_n$, in which N is a factor depending on the ratio of the length to diameter as given in the following table:

| $\frac{\text{Length}}{\text{Diameter}}$ | N |
|---|---------|
| 50 | 0.01817 |
| 100 | 0.00540 |
| 200 | 0.00157 |
| 300 | 0.00075 |
| 400 | 0.00045 |
| 500 | 0.00030 |

However, if the rod has a length at least 400 times its diameter, the correction may be assumed to be negligible.

In the experiment as here discussed, there are two positions in which the rod may be placed, both of which produce fields at the magnetometer at right angles to the earth's or other governing field, whose value is known.

I.

The rod is placed in a solenoid somewhat longer than the specimen to be tested, with its axis in a horizontal plane and in a magnetically east and west line. The field produced at the magnetometer needle will be at right angles to the known horizontal component of the governing field, and the tangent of the angle the needle is deflected from its position of rest in the governing field will give the ratio between the two fields. Under these conditions the equation of Exp. Q₃ may be applied,

$$\frac{M}{f} = \frac{(L^2 - a^2)^2}{2L} \tan \delta,$$

in which f is the known governing field, a is half the distance between the poles, and the other terms have the significance given in the experiment referred to above.

The strength of the magnetizing field within the solenoid may be computed from the expression

$$H = \frac{4\pi nI}{10l}, \quad (377)$$

in which n/l is the number of turns per unit length of the solenoid and I is the current measured in amperes.

Knowing the dimensions of the bar, the distance of its midpoint from the magnetometer, the number of turns and length of the solenoid, the strength of the comparison field; and

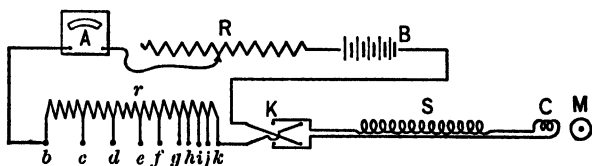

Fig. 132.

observing the current flowing and the deflections of the magnetometer needle, the values of H , I_n , k , B , and μ may be found.

Arrange the circuit as in Fig. 132. A solenoid S is connected in series with a neutralizing coil C , a storage battery B ,

a regulating resistance R , an ammeter or current measuring galvanometer A , a variable resistance r , and a reversing key K . The axis of the solenoid produced passes through the magnetometer needle at M , at right angles to the governing field.

Since the field due to the current in the solenoid affects the magnetometer, the neutralizing coil must be so placed as to reduce this effect to zero. The value of the magnetizing field is controlled by the resistance r . The steps bc , cd , de , etc., are adjusted to give the desired changes in magnetizing field as they are successively short-circuited or added. When increasing the field, the largest resistance bc is to be cut out first, then cd , and so on. When decreasing the field, the resistance units are to be added, beginning at the opposite end and progressing to the largest resistance. An ordinary resistance box may not be used, since it will not carry the required currents safely.

The regulating resistance is used to obtain the desired maximum current. Before making readings the following adjustments should be made :

With r equal to zero vary the value of the regulating resistance R to give a maximum current of 1.2 to 1.5 amperes. This adjustment is not to be disturbed during the experiment.

Place the neutralizing coil in such a position that no deflection of the magnetometer needle is produced when the direction of the current in the coils is reversed, no iron being present.

Center the iron rod to be tested within the solenoid and place the solenoid in such a position that the deflection of the needle for direct or reversed maximum current will be the desired maximum. If the deflections are the same, then the field produced by the rod is at right angles to the governing field.

The rod must be demagnetized before beginning the observations. Either of the following methods may be used: (1) Remove the rod from the solenoid and hold it in the earth's magnetic field in such a direction that this field tends to

demagnetize it. Tap the rod lightly with a block of wood until it no longer deflects the magnetometer needle when one end is held within 50 or 60 centimeters. (2) Place the bar within the solenoid and, starting with the current at a maximum, gradually reduce its value, at the same time rapidly changing its direction; or, note the direction of deflection of the magnetometer and send a current through the solenoid so as to produce a field to demagnetize the bar, starting with a small current and gradually increasing it until the deflection is reduced to zero. Observations are now to be made for finding I_n and μ . Read the ammeter and magnetometer zeros, the switch being open. Close the switch, the resistance r being all in, and make ammeter and magnetometer readings. Cut out the largest step in the resistance r by short-circuiting bc , and read the instruments as before. Continue this process until all of r has been short-circuited and the current is a maximum. Corresponding values of H , I_n , k , B , and μ are to be computed from the data obtained; and three curves are to be drawn, a magnetization curve showing the relation between B and H , a susceptibility curve showing the relation between k and H , and a permeability curve showing the relation between μ and H .

To obtain data for the magnetic hysteresis, reverse the direction of the current at its maximum value ten or fifteen times, then close the switch in either direction and take ammeter and magnetometer readings. Add resistance to the circuit by beginning at the low resistance end of r and make readings as before. Continue the process of adding resistance and making readings until the resistance of r is a maximum, then open the reversing switch and make readings. The magnetometer reading for zero current will enable the computation of the residual magnetism. Close the reversing switch in the opposite direction and make readings as in obtaining data for the magnetization curve. The rod will now be magnetized in the opposite sense. To return to the original magnetic condition completing the cycle, decrease the current to zero, then increase it to a max-

imum in its original direction, making appropriate readings for each step in varying r as before. From the data obtained, compute values of H and corresponding values of I_n and B , and plot the hysteresis loop.

II.

The difficulty of finding accurately the positions of the poles is obviated by Ewing's one-pole method. The magnetizing solenoid and the rod to be tested are placed with their coincident axes in a vertical position, the upper pole, say, of the rod being magnetically east or west of the magnetometer needle. The distance from the needle to the rod is made considerably less than the length of the rod. The arrangement of coils, solenoid, rod, and magnetometer is shown in Fig. 133.

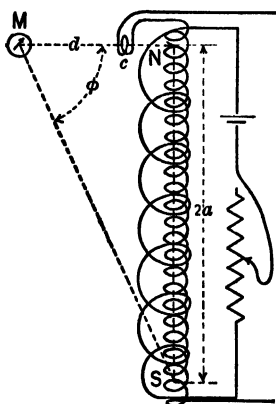

Fig. 133.

The field at the needle due to the magnetized rod is

$$H_m = \frac{m}{d^2} - \frac{m}{d^2 + 4a^2} \cos \phi. \quad (378)$$

If for the pole strength m its equal $I_n q$, intensity of magnetization times area of cross-section, be written in the above equation, then

$$H_m = I_n q \left[\frac{1}{d^2} - \frac{d}{(d^2 + 4a^2)^{\frac{3}{2}}} \right]. \quad (379)$$

The second term within the brackets is a correction factor introduced on account of the effect of the pole at S . This factor becomes smaller the closer the rod is placed to the magnetometer needle and the longer the rod used. If f is the strength of the governing field of the magnetometer and δ is the angular deflection, then

$$\frac{H_m}{f} = \tan \delta. \quad (380)$$

Solving equation 379 for I_n and substituting the value of H_m from equation 378 gives

$$I_n = \frac{f \tan \delta}{g \left[\frac{1}{d^2} - \frac{d}{(d^2 + 4a^2)^{\frac{3}{2}}} \right]} \quad (381)$$

The last equation involves the distance between the poles of the rod, but since the correction is comparatively small, an approximation of the distance $2a$ will not greatly affect the results. The values of I_n having been obtained, the values of k , H , B , and μ may be computed in the same manner as in part I.

The circuit is made up in the same way as in part I. An auxiliary circuit, shown in Fig. 133, composed of a coil to neutralize the magnetizing effect of the vertical component of the earth's field on the bar, a battery, and a resistance are connected in series. The coil is wound on the form carrying the solenoid. The resistance is adjusted to give a current in the proper direction and sufficient to produce a field within the neutralizing coil equal to the vertical component of the earth's field, and in the opposite sense. The auxiliary circuit is necessary only when testing soft iron.

A second neutralizing coil to neutralize the magnetic effect of the solenoid is necessary as in part I.

To get the upper pole in the same horizontal plane as the magnetometer needle, the iron rod is centered within the solenoid, the current given its maximum value, and the frame carrying the solenoid and rod is raised or lowered until the deflection of the needle is a maximum. The frame is then clamped in place, the rod removed, and the small neutralizing coil C adjusted to counteract the magnetic effect of the solenoid on the needle.

The iron rod is then replaced in the solenoid and demagnetized as in the second method of part I.

The connections, excepting as noted above, are the same as indicated in Fig. 132. The same method of making observations and computations is to be followed as that given in part I.

MAGNETIC PROPERTIES OF IRON, MAGNETOMETER METHOD.
HYSTERESIS LOOP.

| I | H | Magnetometer Reading. | Deflection. | $\tan \delta$ | I_n | B |
|-------|--------|-----------------------|-------------|---------------|-------|----------|
| 1.263 | + 54.0 | 10.60 | + 14.40 | .1411 | + 959 | + 12,090 |
| .670 | 28.6 | 12.00 | 13.00 | .1278 | 869 | 10,940 |
| .363 | 15.5 | 13.45 | 11.55 | .1139 | 775 | 9,745 |
| .158 | 6.75 | 15.60 | 9.40 | .0934 | 635 | 7,985 |
| .063 | 2.69 | 17.40 | 7.60 | .0757 | 515 | 6,465 |
| .000 | 0.00 | 19.05 | 5.95 | .0595 | 404 | 5,080 |
| .033 | - 1.41 | 20.50 | 4.50 | .0450 | 358 | 4,495 |
| .061 | 2.61 | 21.85 | 3.15 | .0315 | 214 | 2,685 |
| .112 | 4.78 | 25.90 | - .90 | .0090 | - 61 | - 775 |
| .220 | 9.40 | 30.70 | 5.70 | .0570 | 387 | 4,870 |
| .363 | 15.5 | 34.10 | 9.10 | .0908 | 613 | 7,715 |
| .680 | 29.1 | 37.10 | 12.10 | .1192 | 810 | 10,200 |
| .920 | 39.4 | 38.25 | 13.25 | .1304 | 887 | 11,170 |
| 1.268 | 54.2 | 39.35 | 14.35 | .1407 | 957 | 12,065 |
| .670 | 28.6 | 38.05 | 13.05 | .1284 | 873 | 10,990 |
| .370 | 15.8 | 36.65 | 11.65 | .1150 | 782 | 9,835 |
| .160 | 6.84 | 34.65 | 9.65 | .0956 | 650 | 8,175 |
| .063 | 2.69 | 32.55 | 7.55 | .0751 | 511 | 6,415 |
| .000 | 0.00 | 30.80 | 5.80 | .0578 | 393 | 4,930 |
| .033 | + 1.41 | 29.30 | 4.30 | .0430 | 292 | 3,660 |
| .061 | 2.61 | 27.90 | 2.90 | .0290 | 197 | 2,470 |
| .115 | 4.91 | 24.80 | + .20 | .0020 | + 14 | + 175 |
| .220 | 9.40 | 19.25 | 5.75 | .0574 | 390 | 4,905 |
| .361 | 15.4 | 16.15 | 8.85 | .0879 | 598 | 7,530 |
| .680 | 29.1 | 12.90 | 12.10 | .1192 | 810 | 10,200 |
| .920 | 39.4 | 11.65 | 13.35 | .1312 | 892 | 11,240 |
| 1.268 | 54.2 | 10.65 | 14.35 | .1407 | 957 | 12,065 |

STATION 148.

| | | | |
|----------------------------|--------------|--|---------------|
| Length of rod . . . | 78.3 cm. | Length of solenoid . . . | 95.0 cm. |
| Diameter of rod . . . | .630 cm. | Turns of wire in sol- | |
| Cross-sectional area . . . | .311 sq. cm. | enoid | 3230 |
| Volume of rod, v . . . | 24.3 cu. cm. | Turns per cm. | 34 |
| Dist. between poles, $2a$ | 75.0 cm. | $H = \frac{4\pi nI}{10l} = 42.73 I$ | |
| Distance, center of rod | | Governing field, f . . . | .195 C. G. S. |
| to needle, L . . . | 126.7 cm. | $I_n = \frac{(L^2 - a^2)^2 f}{2Lv} \tan \delta = 68 \times 10^2 \tan \delta$ | |
| Distance of scale from | | | |
| mirror | 50.0 cm. | | |

MAGNETIZATION AND PERMEABILITY.

| Current. | H^* | Magnetometer Reading. | Deflection. | $\tan \delta$ | I_n | k | B | μ |
|----------|-------|-----------------------|-------------|---------------|-------|------|--------|-------|
| .000 | | 25.00 | | | | | | |
| .032 | 1.37 | 24.70 | .30 | .0030 | 20.4 | 14.9 | 257 | 188 |
| .063 | 2.69 | 24.34 | .66 | .0066 | 44.9 | 16.7 | 566 | 210 |
| .112 | 4.78 | 23.25 | 1.75 | .0175 | 119. | 24.9 | 1,498 | 314 |
| .162 | 6.92 | 21.67 | 3.33 | .0333 | 226. | 32.7 | 2,845 | 412 |
| .219 | 9.36 | 19.33 | 5.67 | .0565 | 384. | 41.0 | 4,830 | 516 |
| .370 | 15.8 | 16.08 | 8.92 | .0886 | 606. | 38.3 | 7,630 | 483 |
| .542 | 23.2 | 14.15 | 10.85 | .1069 | 727. | 31.2 | 9,265 | 395 |
| .683 | 29.2 | 13.12 | 11.88 | .1175 | 798. | 27.4 | 10,050 | 345 |
| .932 | 39.8 | 11.90 | 13.10 | .1290 | 877. | 22.0 | 11,050 | 278 |
| 1.268 | 54.2 | 10.75 | 14.25 | .1400 | 952. | 17.6 | 12,010 | 222 |

EXPERIMENT W_2 . Magnetic properties of iron — ballistic method.

In the ballistic method of studying the magnetic properties of iron, the specimen is best used in the form of a closed ring. No corrections are then necessary in the value of the magnetizing field as computed in terms of the number of turns per centimeter length of the coil used to produce it, since there are no free magnetic poles. Values of the magnetizing field and changes of induction can be computed directly from the observations.

It is the object of the experiment to study the relation between B and H for iron initially unmagnetized, to get values of the permeability, and also after the specimen has been fully magnetized to find the hysteresis.

The arrangement of the apparatus is shown in Fig. 134. A ring C of the iron or steel to be tested is wound with two coils, a primary and a secondary. The primary coil is connected in series with a secondary battery B , an ammeter or current

* No correction has been made for the demagnetizing effect of the poles.

measuring galvanometer A , a constant governing resistance R , and a variable resistance r . A reversing key K is inserted in the primary circuit to change the direction of the current in the primary coil. Since the value of the magnetizing field is

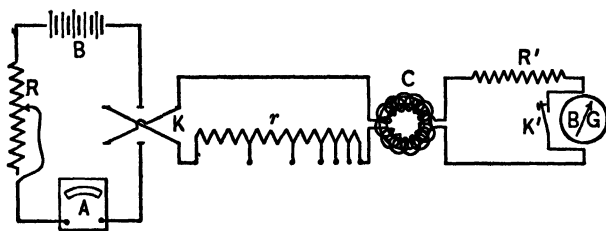

Fig. 134.

governed by the variable resistance r , and this field must be capable of continuous stepwise changes, either increasing or decreasing, the resistance must be so arranged as to permit of such changes without breaking circuit or making steps in the wrong direction.

A satisfactory resistance may be constructed of resistance lamps. The lamps should have such resistances and be so arranged as to permit the desired changes in current strength when short-circuited or inserted into the circuit.

The secondary coil is connected in series with a ballistic galvanometer BG and a resistance box R' . A short-circuiting key K' is connected across the galvanometer terminals. When the current in the primary circuit is changed, the number of lines cutting through the secondary is changed, and an induced current lasting but a very short time is set up in the secondary circuit. This momentary discharge through the galvanometer produces a throw of the galvanometer which, as will be proved later, is proportional to the change in the number of lines of force in the ring. If the ballistic galvanometer is not well damped, to facilitate work some method of damping may be used *after* the throw has been read. The relative motion of the galvanometer coil and permanent magnet, whether the instrument be of the tangent or d'Arsonval type, produces an E. M. F. which

will cause an induced current to flow at the expense of the motion necessary to produce it. The current will be large, and consequently the damping will be large if the resistance in the circuit is small. Hence, to bring the galvanometer needle to rest at zero quickly, it should be short-circuited by means of the key K' in the secondary circuit. In using this key, care must be taken to open it before any change is made in the primary current, otherwise no throw will be obtained.

The rings that are wound for this experiment are rectangular in cross-section and have a primary coil of 1500 turns. For this number of turns the maximum current should be about one ampere. The resistance R in series with the storage battery must be adjusted once for all, so that the maximum value of the current is about one ampere when all the resistance r is cut out.

Before beginning observations for the magnetization curve, the ring must be thoroughly demagnetized. To do this the current in the primary circuit is given its maximum value, and while being rapidly reversed by the key K it is gradually decreased to zero, the key being finally left open. If the current is decreased by steps, it should be reversed several times for each change.

The ring having been demagnetized, the following observations are to be made. The key K being open, read the rest position of the ballistic galvanometer, and also of the ammeter to find its zero error.

All of the resistance in r being in circuit, close the key K , read the throw of the ballistic galvanometer and note the corresponding ammeter reading. When the galvanometer needle is at rest, the key K' in the secondary circuit being open, short circuit the first lamp at the high resistance end of r , noting the corresponding galvanometer throw and ammeter reading.

Continue the above process, cutting out the sections of the resistance r progressively, and reading corresponding galvanometer throws and ammeter readings until the maximum current is reached.

From the data obtained, the values of the magnetizing field may be obtained from the expression

$$H = \frac{4 \pi n I}{10 l}, \quad (377 \text{ bis})$$

in which n is the number of turns of the primary coil, l its mean length, and I the true value of the current in amperes. This formula assumes that H is uniform over the whole cross-section of the coil, which is sufficiently accurate if the radius of the coil is small compared to the radius of the ring on which it is wound.

The method of obtaining B is not so simple. The theory of the method is as follows: As shown in Exp. U₁, in a ballistic galvanometer the throw is proportional to the quantity of electricity that passes through the galvanometer,

$$Q = Q_0 \left(1 + \frac{1}{2} \lambda\right) \sin \frac{1}{2} \delta,$$

or $Q = Q'_0 \left(1 + \frac{1}{2} \lambda\right) s.$ (See equation 324.)

The quantity Q that flows in the secondary circuit due to a change in the number of lines of force passing through it is given by equation 341 (see p. 354),

$$Q = \frac{n_2 N}{10^8 R_s}, \quad (382)$$

where N is the change in the number of lines of force, n_2 the number of turns, and R_s the total resistance of the secondary circuit. If after the ring has been demagnetized, a current is sent through the primary, there will be, say, B_1 lines of magnetic induction set up. The N in equation 382 will equal AB_1 , where A is the area of cross-section of the iron. Therefore the quantity of electricity that goes through the secondary circuit will be given by

$$Q = \frac{n_2 B_1 A}{10^8 R_s}. \quad (383)$$

Combining this with equation 324 and solving for B_1 , we have

$$B_1 = \frac{10^8 R_s Q_0' (1 + \frac{1}{2} \lambda)}{n_2 A} s_1, \quad (384)$$

or

$$B_1 = B_0 s_1. \quad (385)$$

If now the current be again increased, say, to I_2 , and the throw s_2 obtained, we have

$$B_2 = B_0 s_2,$$

where B_2 is the *change* in the induction.

The total induction in the ring due to the current I_2 is equal to the sum of the changes, or

$$B = B_0(s_1 + s_2). \quad (386)$$

If Oe , in Fig. 135, represents the first magnetizing force applied, em is the resulting induction. If the current be increased and the magnetizing force thus increased by the amount ef , the change in the induction is an . If another increment, say, fg , be added to H by another increase in the current, the change in B is bp . Thus the total induction for the point p is given by the sum of all the changes up to that point, or

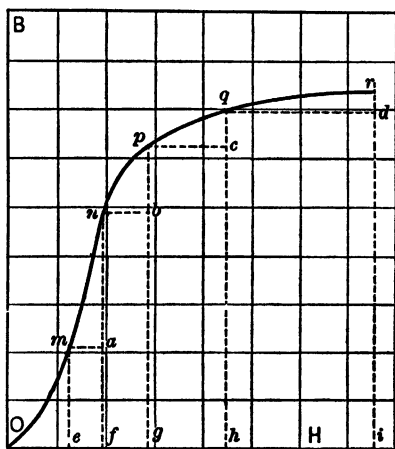

Fig. 135.

$$\begin{aligned} B_p &= B_1 + B_2 + B_3 + \dots \\ &= B_0(s_1 + s_2 + s_3 + \dots). \end{aligned}$$

In general

$$B = B_0 \sum s, \quad (387)$$

where the summation includes all the preceding throws. In this way a series of points is obtained and the magnetization curve drawn.

As is evident from the figure, the magnitude of the change in induction and the corresponding galvanometer throw depends

on the amount of the change in H and the place on the curve where the change is made. Where the curve is very steep, small changes in H should be made, or the galvanometer deflection may be too large to be read.

A preliminary set of observations should be made to determine whether the proper value of resistance R' has been used in series with the ballistic galvanometer. If the largest throw of the galvanometer is not great enough, the resistance should be decreased in approximately the inverse ratio of the maximum throw obtained to the maximum that is desired.

MAGNETIZATION OF IRON BY THE RING METHOD.

| I | Ballistic Galvanometer. | | Throw. | Σs | B | H | μ |
|-------|-------------------------|----------|--------|------------|------|------|-------|
| | Zero. | Reading. | | | | | |
| 0.081 | 45.00 | 45.82 | 0.82 | 0.82 | 62 | 0.68 | 91.2 |
| 0.043 | 45.00 | 46.82 | 1.82 | 2.64 | 200 | 1.95 | 102.5 |
| 0.055 | 45.00 | 46.10 | 1.10 | 3.74 | 283 | 2.50 | 113.0 |
| 0.081 | 45.00 | 47.83 | 2.83 | 6.57 | 498 | 3.66 | 135.0 |
| 0.135 | 45.00 | 54.97 | 9.97 | 16.54 | 1253 | 6.14 | 204.0 |
| 0.183 | 45.00 | 57.65 | 12.65 | 29.19 | 2210 | 8.32 | 268.0 |
| 0.266 | 45.00 | 61.10 | 16.10 | 45.29 | 3430 | 12.1 | 284.0 |
| 0.321 | 45.10 | 52.29 | 7.19 | 52.48 | 3980 | 14.6 | 272.0 |
| 0.438 | 45.05 | 56.31 | 11.26 | 63.74 | 4830 | 20.0 | 242.0 |
| 0.605 | 45.24 | 57.23 | 11.99 | 75.73 | 5740 | 27.5 | 209.0 |
| 1.065 | 45.05 | 63.93 | 18.88 | 94.61 | 7160 | 48.4 | 148.0 |

CAST-IRON RING, RECTANGULAR CROSS-SECTION.

External diameter of ring 15.24 cm.

Internal diameter of ring 11.17 cm.

Thickness of ring 2.06 cm.

Area of cross-section of ring 4.19 sq. cm.

Mean radius of ring 6.60 cm.

Turns in primary coil 1500

$$H = \frac{4\pi n}{10l} I = 45.45 I.$$

Turns in secondary coil 300

Resistance of secondary coil 2.8

Resistance of galvanometer 12.1

Resistance in box 100

Resistance of secondary circuit 114.9

$$\lambda = 0.12. \quad Q_0' = 781 \times 10^{-8}.$$

$$B_0 = 75.8.$$

To obtain data for the study of the hysteresis of the ring, observations must be begun with both B and H at their maximum value, that is, at the point c in Fig. 131. When the current, and thus H , is decreased to zero the history of the change in the iron is given by the line cd . The ordinate od is the residual magnetization of the iron. The sum of the throws in changing H from the maximum value to zero when multiplied by B_0 gives the total change in induction, wd . For any point on the line cd the change in B is proportional to the sum of the throws from c to that point.

At d the current is reversed and increased to a maximum in the opposite direction. The resultant curve is dep . From p the current is decreased to zero at q . The current is reversed at q and increased to a maximum, thus bringing the iron back to c . The sum of the throws in going from c to p should equal the sum from p to c . In general, when starting at the point c , the initial induction is unknown. If the magnetization curve has just been taken, and the loop is taken as a continuation of it, then it is known. But if this is done, the curve obtained may not be re-entrant. It is only after the iron or steel has been carried through the cycle several times that a symmetrical loop will always be obtained. For this reason before commencing observations, the current while at its maximum value should be reversed fifteen or twenty times.

The initial value of the induction, at the point c , may be obtained in the following way: The sum of the throws from c to p by the path $cdep$ is found. This sum when multiplied by B_0 gives the total change in induction from c to p . As the curve must be symmetrical, half of this change will give the initial value of the induction, *i.e.* the ordinate for the point c .

It is not worth while to begin observations until the process is clearly understood. If, while taking the observations for the loop, it be kept in mind that abscissas are proportional to current, and the *change* in the ordinate in going from one point to the next is proportional to the galvanometer throw, there will

be little trouble in following the various steps in the process. Observations are to be made in the same manner as in obtaining data for the magnetization curve and the permeability. It should be noted, however, that sections of the resistance r must be added in the reverse order to obtain a decreasing magnetizing field of approximately equal steps.

HYSTERESIS LOOP. RING METHOD.

| I | Galv. Zero. | Reading. | Throw. | Σr | B | H |
|-------|-------------|----------|--------|------------|---------|--------|
| .752 | 20.10 | — | — | 37.40 | +14,700 | +58.08 |
| .181 | 20.10 | 14.85 | -5.25 | 32.15 | +12,700 | +13.98 |
| .000 | 20.10 | 12.90 | -7.20 | 24.85 | +9,800 | 0.00 |
| -.053 | 20.10 | 8.50 | -11.60 | 13.85 | +5,300 | -4.10 |
| -.075 | 20.20 | 6.65 | -13.55 | -.20 | -80 | -5.79 |
| -.103 | 20.15 | 10.55 | -9.60 | -9.80 | -3,860 | -7.95 |
| -.138 | 20.15 | 12.50 | -7.65 | -17.45 | -6,900 | -10.66 |
| -.184 | 20.13 | 14.53 | -5.60 | -23.05 | -9,100 | -14.21 |
| -.324 | 20.14 | 12.84 | -7.30 | -30.35 | -11,900 | -25.02 |
| -.752 | 20.14 | 13.09 | -7.05 | -37.40 | -14,700 | -58.08 |
| -.183 | 20.10 | 25.40 | 5.30 | -32.10 | -12,630 | -14.13 |
| .000 | 20.10 | 27.25 | 7.15 | -24.95 | -9,800 | 0.00 |
| .053 | 20.10 | 31.65 | 11.55 | -13.40 | -5,272 | +4.10 |
| .075 | 20.15 | 33.65 | 13.50 | .10 | +40 | +5.79 |
| .103 | 20.15 | 29.70 | 9.55 | 9.65 | +3,800 | +7.95 |
| .138 | 20.15 | 27.85 | 7.70 | 17.35 | +6,800 | +10.66 |
| .183 | 20.15 | 25.80 | 5.65 | 23.00 | +9,150 | +14.13 |
| .321 | 20.15 | 27.50 | 7.35 | 30.35 | +11,900 | +24.79 |
| .756 | 20.15 | 27.10 | 6.95 | 37.30 | +14,700 | +58.38 |

ANNEALED TOOL STEEL RING, RECTANGULAR CROSS-SECTION.

| | | | |
|---|-----------|---|-------------|
| External diameter of ring | 14.96 cm. | Turns in secondary coil | 500 |
| Internal diameter of ring | 10.92 cm. | Resistance of secondary coil | 5 ohms |
| Thickness of ring | 1.70 cm. | Resistance in galv. | 110 ohms |
| Area of cross-section of ring | 3.434 | Resistance in box | 10,000 ohms |
| Mean radius of ring | 6.47 | Total resistance of secondary | 10,115 ohms |
| Turns in primary coil | 2500 | $\lambda = .10.$ | |
| $H = \frac{4\pi nI}{10l} = 77.23I.$ | | $Q_0' = 639 \times 10^{-9}.$ | |
| | | $B_0 = 393.5.$ | |

A trial run should be made to obtain a desirable resistance in the secondary circuit. In general the same secondary resistance will not be suitable for the two sets of data.

Three curves are to be plotted and presented in the report: the magnetization curve, with H and B ; the permeability curve, with H and μ ; and the hysteresis loop, with H and B as coordinates.

The observations and results given on the preceding page are for a ring of annealed tool steel. In this table the initial value for Σs of 37.40 was obtained as follows: The sum of the throws in going from a maximum value of the current in one direction to the maximum value in the reversed direction was found to be 74.80. One half of this was taken as the initial value. No values for μ are given, since permeability applies only to iron originally unmagnetized.

TABLES.

[In the tables of logarithms and natural trigonometric functions the admirable arrangement made use of in Bottomley's *Four-Figure Mathematical Tables* has been followed.]

I. SOME USEFUL NUMBERS.

| | | |
|------------------|------------------|---------------------|
| $\pi = 3.1416$ | $2\pi = 6.283$ | $4\pi = 12.57$ |
| $\pi^2 = 9.87$ | $4\pi^2 = 39.48$ | $1/\pi = 0.318$ |
| $1/2\pi = 0.159$ | $\pi/4 = 0.785$ | $\log \pi = 0.4971$ |

Napierian base $e = 2.7183$.

$$\log_e N = \frac{\log_{10} N}{\log_{10} e} = 2.3026 \log_{10} N.$$
$$\log_{10} e = .43429.$$

1 radian = $57^\circ.3$.

1 degree = 0.01745 radian.

1 inch = 25.4 mm.

1 meter = 39.37 inches.

1 kilogram = 2.2 pounds.

1 pound = 453.6 grams.

Approximate value of $g = 980$. $\sqrt{980} = 14\sqrt{5} = 31.3+$
 $1/\sqrt{980} = 0.032$

2. WORK AND POWER.

1 joule = 10^7 ergs.

1 watt = 1 joule per second.

1 horse power = 746 watts = 550 ft.-lb./sec.

1 French horse power = 75 kg. m./sec.

Mechanical equivalent of heat = 4.18×10^7 ergs.

3. DENSITIES OF SOME SUBSTANCES.

| Solids. | | | |
|---|-----------|------------------------|-----------|
| Aluminum | 2.6 | Lead | 11.3 |
| Beeswax | 0.96 | Nickel | 8.9 |
| Brass | 8.1-8.7 | Paraffin | 0.87-0.93 |
| Copper | 8.9 | Platinum | 21.5 |
| Cork | .14- .3 | Silver | 10.5 |
| German silver | 8.5 | Tin | 7.3 |
| Glass, common | 2.4-2.7 | | |
| Glass, flint | 3.0-5.9 | Woods seasoned : | |
| Hard rubber | 1.15 | Oak | 0.7-1.0 |
| Iron, cast | 7.1-7.7 | Pine | 0.5 |
| Iron, wrought | 7.7 | | |
| Iron, steel | 7.8 | Zinc | 7.1 |
| Liquids at 20° C. | | | |
| Alcohol, ethyl | 0.789 | Glycerin | 1.23 |
| Alcohol, methyl | 0.810 | Mercury | 13.596 |
| Ammonium chloride, 10% . | 1.030 | Sodium chloride, 10% . | 1.071 |
| Carbon bisulphide | 1.264 | Zinc sulphate, 10% . . | 1.107 |
| Copper sulphate, 10% . . | 1.107 | | |
| Gases under Standard Conditions, <i>i.e.</i> at 0° C. and 76 cm. of Hg. Pressure. | | | |
| Air | 0.001293 | g. per cu. cm. | |
| Carbon dioxide | 0.001974 | g. per cu. cm. | |
| Coal gas | 0.00046 | g. per cu. cm. | |
| Hydrogen | 0.0000900 | g. per cu. cm. | |
| Nitrogen | 0.001257 | g. per cu. cm. | |
| Oxygen | 0.001430 | g. per cu. cm. | |

4. COEFFICIENTS OF FRICTION.

| Materials. | μ (Approximate). |
|---|----------------------|
| Brass on cast iron | 0.19 |
| Oak on oak fibers, parallel | 0.48 |
| Oak on oak fibers, perpendicular | 0.22 |
| Pine on cast iron | 0.20 |
| Wrought iron on cast iron | 0.20 |
| Wrought iron on wrought iron | 0.14 |
| Smooth and well-lubricated surfaces | 0.04 |

5. ELASTIC CONSTANTS.

| Substances. | Young's Modulus. Dynes per sq. cm. | Simple Rigidity. Dynes per sq. cm. |
|-------------------------|---------------------------------------|---------------------------------------|
| Aluminum | 6.5×10^{11} | $2.4-3.3 \times 10^{11}$ |
| Brass | 8.3- 9.7 | 3.1-3.6 |
| Copper | 9.8-12.0 | 4.5 |
| Glass | 6.0- 7.0 | 2.4 |
| Iron, wrought | 19.3-20.9 | 7.7-8.0 |
| Iron, steel | 19.0-22.0 | 8.0-8.8 |
| Woods, oak | 1.0 | 0.07 |
| Woods, pine | 1.1 | 0.10 |

6. DATA ON CHANGE OF STATE.

| Substances. | Melting Point. | Heat of Fusion.* | Boiling Point. | Heat of Vaporization.* | Heat of Combustion.* |
|----------------------------|----------------|------------------|----------------|------------------------|----------------------|
| Charcoal | | | | | 7070 to 8080 |
| Coal, soft | | | | | 7400 to 8800 |
| Coal, anthracite | | | | | 7850 |
| Petroleum | | | | | 11050 |
| Wood | | | | | 4100 to 4500 |
| Acetic acid | | | 188 | 84.9 | |
| Alcohol, ethyl | | | 78 | 205 | 7180 |
| Alcohol, methyl | | | 64.5 | 267.5 | 5310 |
| Mercury | -39 | 2.8 | 357 | 62 | |
| Water | 0 | 80.00 | 100 | 537 | |
| Acetylene † | | | | | 14500 |
| Coal gas † | | | | | 1000 to 1400 |
| Hydrogen † | | | | | 3090 |
| Water gas † | | | | | 2000 to 3500 |

* Expressed in calories per gram.
† Expressed in calories per liter at 0° C. and 76 cm. Hg. pressure.

7. VARIATION IN BOILING POINT OF WATER WITH CHANGE IN BAROMETRIC PRESSURE.

| Pressure in cm. of Hg. | Boiling Point in °C. | Pressure in cm. of Hg. | Boiling Point in °C. |
|------------------------|----------------------|------------------------|----------------------|
| 70 | 97.71 | 75 | 99.63 |
| 71 | 98.11 | 76 | 100.00 |
| 72 | 98.49 | 77 | 100.37 |
| 73 | 98.88 | 78 | 100.73 |
| 74 | 99.26 | 79 | 101.09 |

8. SPECIFIC HEATS AND COEFFICIENTS OF EXPANSION.

| Substance. | Specific Heat. | Linear Coefficient of Expansion. | Substance. | Specific Heat. | Linear Coefficient of Expansion. |
|------------------|----------------|----------------------------------|----------------|----------------|----------------------------------|
| Aluminum . . | 0.206 | 0.000023 | Iron | 0.117 | 0.000011 |
| Brass | 0.093 | 0.000019 | Lead | 0.0305 | 0.000029 |
| Copper | 0.0927 | 0.000017 | Platinum . . | 0.0324 | 0.000009 |
| German silver | 0.095 | 0.000018 | Silver | 0.0561 | 0.000019 |
| Glass | 0.188 | 0.000008 | Zinc | 0.0939 | 0.000029 |
| Ice | 0.474 | 0.000038 | | | |
| | | Volume Coefficient. | | | Volume Coefficient. |
| Acetic acid . . | 0.50 | 0.00107 | Mercury . . . | 0.334 | 0.000181 |
| Alcohol, ethyl . | 0.58 | 0.00110 | Water | 1.0 | 0.000065 |

| Substance. | Specific Heat at Constant Pressure. | $\frac{C_p}{C_v}$ | Pressure Coefficient at Constant Volume. |
|------------------------|-------------------------------------|-------------------|--|
| Air | 0.238 | 1.403 | 0.003663 |
| Carbon dioxide | 0.206 | 1.264 | 0.003668 |
| Hydrogen | 3.238 | 1.414 | 0.003667 |
| Nitrogen | 0.244 | 1.414 | 0.003668 |
| Oxygen | 0.218 | 1.408 | 0.003668 |
| Steam | 0.48 | | |

9. VAPOR PRESSURE OF SATURATED VAPORS IN CENTIMETERS OF MERCURY AT VARIOUS TEMPERATURES.

| Temperature °C. | Ethyl Alcohol. | Water. | Temperature °C. | Ethyl Alcohol. | Water. |
|-----------------|----------------|--------|-----------------|----------------|--------|
| 0 | 1.22 | .46 | 55 | | 11.75 |
| 5 | | .65 | 60 | 35.0 | 14.89 |
| 10 | 2.38 | .91 | 65 | | 18.71 |
| 15 | | 1.27 | 70 | 54.1 | 23.33 |
| 20 | 4.40 | 1.74 | 75 | | 28.88 |
| 25 | | 2.35 | 80 | 81.2 | 35.49 |
| 30 | 7.81 | 3.15 | 85 | | 43.32 |
| 35 | | 4.18 | 90 | 118.7 | 52.55 |
| 40 | 13.37 | 5.49 | 95 | | 63.37 |
| 45 | | 7.14 | 100 | 169.2 | 76.00 |
| 50 | 22.0 | 9.20 | 150 | 736.9 | 358.1 |

10. VAPOR PRESSURE AND RELATIVE HUMIDITY.

The ratio of the mass of aqueous vapor in a given volume of air at a given temperature, to the mass of aqueous vapor in the same volume at the same temperature when saturated, is called the *relative humidity*. Since this ratio is very nearly equal to the ratio of the vapor pressures under like conditions for ordinary atmospheric temperatures, the vapor pressures are commonly used in finding the relative humidity.

An instrument used to determine relative humidity is called an hygrometer. The wet and dry bulb hygrometer consists, as its name implies, of two thermometers, the bulb of one being kept dry and the other wet by means of a wick which conducts water up to a muslin wrapping about the bulb. The evaporation of moisture from the wet bulb requires heat, some of which is abstracted from the wet bulb, thus reducing its temperature. The depression varies with the temperature and the amount of water vapor present in the air.

From the following table, based on Table 170 of the Smithsonian Physical Tables, showing the relation between the temperatures of the two thermometers and the vapor pressure, the relative humidity may be computed. The left-hand column gives dry bulb thermometer readings, and the succeeding columns give vapor pressures corresponding to the wet bulb thermometer depressions indicated in the top row. Saturation pressures are those corresponding to no wet bulb thermometer depressions.

DRY BULB TEMPERATURES AND WET BULB DEPRESSIONS.

| T° C. | 0. | 1. | 2. | 3. | 4. | 5. | 6. | 7. | 8. | 9. | 10. |
|-------|------|------|------|------|------|------|------|------|------|------|------|
| 0 | 4.6 | 3.7 | 2.9 | 2.1 | 1.3 | | | | | | |
| 1 | 4.9 | 4.1 | 3.2 | 2.4 | 1.6 | | | | | | |
| 2 | 5.3 | 4.4 | 3.6 | 2.7 | 1.9 | 1.1 | 0.3 | | | | |
| 3 | 5.7 | 4.8 | 3.9 | 3.1 | 2.2 | 1.4 | 0.6 | | | | |
| 4 | 6.1 | 5.2 | 4.3 | 3.4 | 2.6 | 1.8 | 0.9 | | | | |
| 5 | 6.5 | 5.6 | 4.7 | 3.8 | 2.9 | 2.1 | 1.2 | | | | |
| 6 | 7.0 | 6.0 | 5.1 | 4.2 | 3.3 | 2.4 | 1.6 | | | | |
| 7 | 7.5 | 6.5 | 5.5 | 4.6 | 3.6 | 2.8 | 1.9 | 1.1 | 0.2 | | |
| 8 | 8.0 | 7.0 | 6.0 | 5.0 | 4.1 | 3.2 | 2.3 | 1.4 | 0.6 | | |
| 9 | 8.6 | 7.5 | 6.5 | 5.5 | 4.5 | 3.6 | 2.7 | 1.8 | 0.9 | | |
| 10 | 9.2 | 8.1 | 7.0 | 6.0 | 5.0 | 4.0 | 3.1 | 2.2 | 1.3 | | |
| 11 | 9.8 | 8.7 | 7.6 | 6.5 | 5.5 | 4.5 | 3.5 | 2.6 | 1.7 | | |
| 12 | 10.5 | 9.3 | 8.2 | 7.1 | 6.0 | 5.0 | 4.0 | 3.0 | 2.1 | 1.2 | 0.3 |
| 13 | 11.2 | 10.0 | 8.9 | 7.6 | 6.5 | 5.5 | 4.5 | 3.5 | 2.5 | 1.6 | 0.7 |
| 14 | 11.9 | 10.7 | 9.4 | 8.3 | 7.1 | 6.1 | 5.0 | 4.0 | 3.0 | 2.0 | 1.1 |
| 15 | 12.7 | 11.4 | 10.1 | 9.0 | 7.8 | 6.6 | 5.5 | 4.5 | 3.4 | 2.5 | 1.5 |
| 16 | 13.5 | 12.2 | 10.9 | 9.7 | 8.4 | 7.3 | 6.0 | 5.0 | 4.0 | 3.0 | 1.9 |
| 17 | 14.4 | 13.0 | 11.7 | 10.4 | 9.1 | 8.0 | 6.7 | 5.6 | 4.5 | 3.5 | 2.4 |
| 18 | 15.4 | 13.9 | 12.5 | 11.2 | 9.9 | 8.6 | 7.4 | 6.3 | 5.1 | 4.0 | 3.0 |
| 19 | 16.3 | 14.9 | 13.4 | 12.0 | 10.7 | 9.4 | 8.1 | 6.9 | 5.7 | 4.6 | 3.5 |
| 20 | 17.4 | 15.9 | 14.3 | 12.9 | 11.5 | 10.2 | 8.8 | 7.6 | 6.4 | 5.2 | 4.1 |
| 21 | 18.5 | 16.9 | 15.3 | 13.8 | 12.4 | 11.0 | 9.6 | 8.4 | 7.1 | 5.9 | 4.7 |
| 22 | 19.7 | 18.0 | 16.4 | 14.8 | 13.3 | 11.9 | 10.5 | 9.1 | 7.8 | 6.6 | 5.4 |
| 23 | 20.9 | 19.2 | 17.5 | 15.9 | 14.3 | 12.8 | 11.3 | 10.0 | 8.6 | 7.3 | 6.1 |
| 24 | 22.2 | 20.4 | 18.6 | 17.0 | 15.3 | 13.8 | 12.3 | 10.9 | 9.4 | 8.1 | 6.8 |
| 25 | 23.5 | 21.7 | 19.9 | 18.1 | 16.4 | 14.8 | 13.3 | 11.8 | 10.3 | 9.0 | 7.6 |
| 26 | 25.0 | 23.1 | 21.1 | 19.4 | 17.6 | 15.9 | 14.3 | 12.8 | 11.3 | 9.8 | 8.4 |
| 27 | 26.5 | 24.5 | 22.5 | 20.7 | 18.8 | 17.1 | 15.4 | 13.8 | 12.3 | 10.8 | 9.3 |
| 28 | 28.1 | 26.0 | 24.0 | 22.0 | 20.1 | 18.3 | 16.6 | 14.9 | 13.3 | 11.8 | 10.2 |
| 29 | 29.8 | 27.6 | 25.5 | 23.5 | 21.5 | 19.6 | 17.8 | 16.1 | 14.4 | 12.8 | 11.2 |
| 30 | 31.5 | 29.3 | 27.1 | 25.0 | 22.9 | 21.0 | 19.1 | 17.3 | 15.5 | 13.9 | 12.3 |
| 31 | 33.4 | 31.1 | 28.8 | 26.6 | 24.5 | 22.4 | 20.4 | 18.5 | 16.7 | 15.0 | 13.4 |

II. INDEX OF REFRACTION FOR SODIUM LIGHT.

| | |
|--------------------------------------|-------------|
| Alcohol | 1.362 |
| Canada balsam | 1.54 |
| Carbon bisulphide | 1.628 |
| Glass, crown | 1.515-1.615 |
| Glass, flint | 1.609-1.754 |
| Water | 1.333 |
| Calcite, ordinary ray | 1.659 |
| Calcite, extraordinary ray | 1.486 |
| Quartz, ordinary ray | 1.544 |
| Quartz, extraordinary ray | 1.553 |

12. BRIGHT LINE SPECTRA.

Some Wave Lengths in Air at Ordinary Temperatures and Pressures.

| Element. | | How Produced. | Wave Length in 10^{-8} Cm. | Color. |
|--------------------|----|-----------------|---------------------------------|--------|
| Calcium | Ca | Flame | 4227 | Blue |
| Cadmium | Cd | Flame and spark | 6439 | Red |
| | | | 5086 | Green |
| | | | 4800 | Blue |
| | | | 4679 | Blue |
| Helium | He | Vacuum tube | 7065 | Red |
| | | | 6678 | Red |
| | | | 5876 | Yellow |
| | | | 5016 | Green |
| | | | 4922 | Blue |
| | | | 4713 | Blue |
| | | | 4472 | Violet |
| Hydrogen | H | Vacuum tube | 6563 | Red |
| | | | 4862 | Blue |
| | | | 4341 | Violet |
| | | | 4102 | Violet |

| Element. | | How Produced. | Wave Length in 10^{-8} Cm. | Color. |
|---------------------|----|---------------|---------------------------------|--------|
| Lead | Pb | Spark | 6657 | Red |
| | | | 5608 | Green |
| | | | 4387 | Violet |
| | | | 4245 | Violet |
| | | | 4058 | Violet |
| Lithium | Li | Flame | 6708 | Red |
| | | | 6104 | Red |
| Mercury | Hg | Vacuum tube | 6153 | Orange |
| | | | 5791 | Yellow |
| | | | 5770 | Yellow |
| | | | 5461 | Green |
| | | | 4359 | Violet |
| Nickel | Ni | Spark | 4047 | Violet |
| | | | 5893 | Yellow |
| | | | 4874 | Blue |
| | | | 4866 | Blue |
| | | | 4856 | Blue |
| Potassium | K | Flame | 4715 | Blue |
| | | | 4402 | Violet |
| | | | 7702 | Red |
| | | | 7669 | Red |
| | | | 4047 | Violet |
| Sodium | Na | Flame | 4044 | Violet |
| | | | 5896 | Yellow |
| Strontium | Sr | Flame | 5890 | Yellow |
| | | | 4608 | Blue |
| Thallium | Tl | Flame | 5351 | Green |
| Zinc | Zn | Spark | 6364 | Red |
| | | | 6103 | Red |
| | | | 4925 | Blue |
| | | | 4811 | Blue |
| | | | 4723 | Blue |
| | | | 4680 | Blue |

13. VELOCITY OF SOUND AT 0° C. AND 760 MM. HG.
PRESSURE.

| Substance. | Velocity in Meters per Second. |
|----------------------------|--------------------------------|
| Air | 332.5 |
| Carbon dioxide | 261.6 |
| Illuminating gas | 490.0 |
| Hydrogen | 1286.4 |
| Oxygen | 317.2 |
| Brass | 3500 |
| Copper | 3560 |
| Glass | 5000-6000 |
| Iron | 5000 |

14. SPECIFIC RESISTANCE AND TEMPERATURE COEFFICIENTS.

| Substance. | Specific Resistance in Ohms $\times 10^{-6}$. | Temperature Coefficient. |
|--|--|--------------------------|
| Aluminum | 2.91 | 0.00435 |
| Copper (annealed) | 1.59 | 0.00428 |
| Copper (hard-drawn) | 1.62 | 0.00388 |
| German silver (4 Cu + 2 Ni + 1 Zn) | 20.24 | 0.000273 |
| Iron (annealed) | 9.69 | 0.00625 |
| Manganin (Cu 84%, Mn 12%, Ni 4%) | 41.00 | 0.000025 |
| Mercury | 94.07 | 0.000883 |
| Platinum | 8.96 | 0.00345 |
| Silver | 1.52 | 0.00377 |

15. ELECTRO-CHEMICAL EQUIVALENTS.

| Element. | Atomic Weight. | Valence. | Equivalent in Grams per Coulomb. |
|--------------------|----------------|----------|----------------------------------|
| Copper | 63.6 | 2 | 0.000329 |
| Hydrogen | 1.008 | 1 | 0.000105 |
| Lead | 206.9 | 2 | 0.001072 |
| Oxygen | 16.0 | 2 | 0.000829 |
| Silver | 107.9 | 1 | 0.001118 |
| Zinc | 65.4 | 2 | 0.000339 |

16. SPECIFIC RESISTANCES OF ELECTROLYTES.

| Substance. | Per Cent of Solution. | Density at 18° C. | Gram Molecules per Liter. | Specific Resistance in Ohms per Cc. |
|--|-----------------------|-------------------|---------------------------|-------------------------------------|
| CuSO ₄ | 5 | 1.0531 | 0.658 | 50.9 |
| | 10 | 1.1073 | 1.387 | 30.0 |
| | 15 | 1.1675 | 2.194 | 22.8 |
| H ₂ SO ₄ | 5 | 1.0331 | 1.053 | 4.61 |
| | 10 | 1.0673 | 2.176 | 2.46 |
| | 15 | 1.1036 | 3.376 | 1.77 |
| | 20 | 1.1414 | 4.655 | 1.47 |
| NaCl | 5 | 1.0345 | 0.884 | 14.3 |
| | 10 | 1.0707 | 1.830 | 7.94 |
| | 15 | 1.1087 | 2.843 | 5.86 |
| | 20 | 1.1477 | 3.924 | 4.91 |
| ZnSO ₄ | 5 | 1.0509 | 0.653 | 50.3 |
| | 10 | 1.1069 | 1.365 | 29.9 |
| | 15 | 1.1675 | 2.169 | 23.2 |
| | 20 | 1.2323 | 3.053 | 20.5 |

17. ELECTROMOTIVE FORCE OF CELLS.

| | |
|-----------------------------------|--------------------------------|
| Edison Lalande 0.90 | LeClanché 1.4-1.7 |
| Daniell 1.08 | Bichromate 2.0 |
| Gravity 1.1 | Storage 2.0 |
| Dry Cell 1.4 | |
| E. M. F. Standard Cells at 20° C. | |
| Clark 1.427 | Weston (Cadmium) 1.019 |

18. WIRE GAUGE AND COPPER RESISTANCE TABLE.

| Size. B. & S. Gauge. | Diameter in Inches. | Ohms per 1000 Feet. | Feet per Ohm. |
|-------------------------|---------------------|---------------------|---------------|
| 0 | 0.32495 | 0.0983 | 10166 |
| 4 | 0.20431 | 0.2487 | 4021 |
| 8 | 0.12849 | 0.6288 | 1590 |
| 10 | 0.10189 | 1.0000 | 1000 |
| 12 | 0.08081 | 1.590 | 629 |
| 14 | 0.06408 | 2.528 | 396 |
| 16 | 0.05082 | 4.019 | 248.8 |
| 18 | 0.04030 | 6.391 | 156.5 |
| 20 | 0.03196 | 10.163 | 98.4 |
| 24 | 0.02010 | 25.695 | 38.92 |
| 28 | 0.01264 | 64.97 | 15.39 |
| 32 | 0.00795 | 164.3 | 6.09 |
| 36 | 0.00500 | 415.2 | 2.41 |
| 40 | 0.00314 | 1049.7 | 0.953 |

| | 0 | 1 | 2 | 3 | 4 | 5 | 6 | 7 | 8 | 9 | 12 | 3 | 4 | 5 | 6 | 7 | 8 | 9 | |
|----|------|------|------|------|------|------|------|------|------|------|----|---|----|----|----|----|----|----|----|
| 10 | 0000 | 0043 | 0086 | 0128 | 0170 | 0212 | 0253 | 0294 | 0334 | 0374 | 4 | 8 | 12 | 17 | 21 | 25 | 29 | 33 | 37 |
| 11 | 0414 | 0453 | 0492 | 0531 | 0569 | 0607 | 0645 | 0682 | 0719 | 0755 | 4 | 8 | 11 | 15 | 19 | 23 | 26 | 30 | 34 |
| 12 | 0792 | 0828 | 0864 | 0899 | 0934 | 0969 | 1004 | 1038 | 1072 | 1106 | 3 | 7 | 10 | 14 | 17 | 21 | 24 | 28 | 31 |
| 13 | 1139 | 1173 | 1206 | 1239 | 1271 | 1303 | 1335 | 1367 | 1399 | 1430 | 3 | 6 | 10 | 13 | 16 | 19 | 23 | 26 | 29 |
| 14 | 1461 | 1492 | 1523 | 1553 | 1584 | 1614 | 1644 | 1673 | 1703 | 1732 | 3 | 6 | 9 | 12 | 15 | 18 | 21 | 24 | 27 |
| 15 | 1761 | 1790 | 1818 | 1847 | 1875 | 1903 | 1931 | 1959 | 1987 | 2014 | 3 | 6 | 8 | 11 | 14 | 17 | 20 | 22 | 25 |
| 16 | 2041 | 2068 | 2095 | 2122 | 2148 | 2175 | 2201 | 2227 | 2253 | 2279 | 3 | 5 | 8 | 11 | 13 | 16 | 18 | 21 | 24 |
| 17 | 2304 | 2330 | 2355 | 2380 | 2405 | 2430 | 2455 | 2480 | 2504 | 2529 | 2 | 5 | 7 | 10 | 12 | 15 | 17 | 20 | 22 |
| 18 | 2553 | 2577 | 2601 | 2625 | 2648 | 2672 | 2695 | 2718 | 2742 | 2765 | 2 | 5 | 7 | 9 | 12 | 14 | 16 | 19 | 21 |
| 19 | 2788 | 2810 | 2833 | 2856 | 2878 | 2900 | 2923 | 2945 | 2967 | 2989 | 2 | 4 | 7 | 9 | 11 | 13 | 16 | 18 | 20 |
| 20 | 3010 | 3032 | 3054 | 3075 | 3096 | 3118 | 3139 | 3160 | 3181 | 3201 | 2 | 4 | 6 | 8 | 11 | 13 | 15 | 17 | 19 |
| 21 | 3222 | 3243 | 3263 | 3284 | 3304 | 3324 | 3345 | 3365 | 3385 | 3404 | 2 | 4 | 6 | 8 | 10 | 12 | 14 | 16 | 18 |
| 22 | 3424 | 3444 | 3464 | 3483 | 3502 | 3522 | 3541 | 3560 | 3579 | 3598 | 2 | 4 | 6 | 8 | 10 | 12 | 14 | 15 | 17 |
| 23 | 3617 | 3636 | 3655 | 3674 | 3692 | 3711 | 3729 | 3747 | 3766 | 3784 | 2 | 4 | 6 | 7 | 9 | 11 | 13 | 15 | 17 |
| 24 | 3802 | 3820 | 3838 | 3856 | 3874 | 3892 | 3909 | 3927 | 3945 | 3962 | 2 | 4 | 5 | 7 | 9 | 11 | 12 | 14 | 16 |
| 25 | 3979 | 3997 | 4014 | 4031 | 4048 | 4065 | 4082 | 4099 | 4116 | 4133 | 2 | 3 | 5 | 7 | 9 | 10 | 12 | 14 | 15 |
| 26 | 4150 | 4166 | 4183 | 4200 | 4216 | 4232 | 4249 | 4265 | 4281 | 4298 | 2 | 3 | 5 | 7 | 8 | 10 | 11 | 13 | 15 |
| 27 | 4314 | 4330 | 4346 | 4362 | 4378 | 4393 | 4409 | 4425 | 4440 | 4456 | 2 | 3 | 5 | 6 | 8 | 9 | 11 | 13 | 14 |
| 28 | 4472 | 4487 | 4502 | 4518 | 4533 | 4548 | 4564 | 4579 | 4594 | 4609 | 2 | 3 | 5 | 6 | 8 | 9 | 11 | 12 | 14 |
| 29 | 4624 | 4639 | 4654 | 4669 | 4683 | 4698 | 4713 | 4728 | 4742 | 4757 | 1 | 3 | 4 | 6 | 7 | 9 | 10 | 12 | 13 |
| 30 | 4771 | 4786 | 4800 | 4814 | 4829 | 4843 | 4857 | 4871 | 4886 | 4900 | 1 | 3 | 4 | 6 | 7 | 9 | 10 | 11 | 13 |
| 31 | 4914 | 4928 | 4942 | 4955 | 4969 | 4983 | 4997 | 5011 | 5024 | 5038 | 1 | 3 | 4 | 6 | 7 | 8 | 10 | 11 | 12 |
| 32 | 5051 | 5065 | 5079 | 5092 | 5105 | 5119 | 5132 | 5145 | 5159 | 5172 | 1 | 3 | 4 | 5 | 7 | 8 | 9 | 11 | 12 |
| 33 | 5185 | 5198 | 5211 | 5224 | 5237 | 5250 | 5263 | 5276 | 5289 | 5302 | 1 | 3 | 4 | 5 | 6 | 8 | 9 | 10 | 12 |
| 34 | 5315 | 5328 | 5340 | 5353 | 5366 | 5378 | 5391 | 5403 | 5416 | 5428 | 1 | 3 | 4 | 5 | 6 | 8 | 9 | 10 | 11 |
| 35 | 5441 | 5453 | 5465 | 5478 | 5490 | 5502 | 5514 | 5527 | 5539 | 5551 | 1 | 2 | 4 | 5 | 6 | 7 | 9 | 10 | 11 |
| 36 | 5563 | 5575 | 5587 | 5599 | 5611 | 5623 | 5635 | 5647 | 5658 | 5670 | 1 | 2 | 4 | 5 | 6 | 7 | 8 | 10 | 11 |
| 37 | 5682 | 5694 | 5705 | 5717 | 5729 | 5740 | 5752 | 5763 | 5775 | 5786 | 1 | 2 | 3 | 5 | 6 | 7 | 8 | 9 | 10 |
| 38 | 5798 | 5809 | 5821 | 5832 | 5843 | 5855 | 5866 | 5877 | 5888 | 5899 | 1 | 2 | 3 | 5 | 6 | 7 | 8 | 9 | 10 |
| 39 | 5911 | 5922 | 5933 | 5944 | 5955 | 5966 | 5977 | 5988 | 5999 | 6010 | 1 | 2 | 3 | 4 | 5 | 7 | 8 | 9 | 10 |
| 40 | 6021 | 6031 | 6042 | 6053 | 6064 | 6075 | 6085 | 6096 | 6107 | 6117 | 1 | 2 | 3 | 4 | 5 | 6 | 8 | 9 | 10 |
| 41 | 6128 | 6138 | 6149 | 6160 | 6170 | 6180 | 6191 | 6201 | 6212 | 6222 | 1 | 2 | 3 | 4 | 5 | 6 | 7 | 8 | 9 |
| 42 | 6232 | 6243 | 6253 | 6263 | 6274 | 6284 | 6294 | 6304 | 6314 | 6325 | 1 | 2 | 3 | 4 | 5 | 6 | 7 | 8 | 9 |
| 43 | 6335 | 6345 | 6355 | 6365 | 6375 | 6385 | 6395 | 6405 | 6415 | 6425 | 1 | 2 | 3 | 4 | 5 | 6 | 7 | 8 | 9 |
| 44 | 6435 | 6444 | 6454 | 6464 | 6474 | 6484 | 6493 | 6503 | 6513 | 6522 | 1 | 2 | 3 | 4 | 5 | 6 | 7 | 8 | 9 |
| 45 | 6532 | 6542 | 6551 | 6561 | 6571 | 6580 | 6590 | 6599 | 6609 | 6618 | 1 | 2 | 3 | 4 | 5 | 6 | 7 | 8 | 9 |
| 46 | 6628 | 6637 | 6646 | 6656 | 6665 | 6675 | 6684 | 6693 | 6702 | 6712 | 1 | 2 | 3 | 4 | 5 | 6 | 7 | 7 | 8 |
| 47 | 6721 | 6730 | 6739 | 6749 | 6758 | 6767 | 6776 | 6785 | 6794 | 6803 | 1 | 2 | 3 | 4 | 5 | 5 | 6 | 7 | 8 |
| 48 | 6812 | 6821 | 6830 | 6839 | 6848 | 6857 | 6866 | 6875 | 6884 | 6893 | 1 | 2 | 3 | 4 | 4 | 5 | 6 | 7 | 8 |
| 49 | 6902 | 6911 | 6920 | 6928 | 6937 | 6946 | 6955 | 6964 | 6972 | 6981 | 1 | 2 | 3 | 4 | 4 | 5 | 6 | 7 | 8 |
| 50 | 6990 | 6998 | 7007 | 7016 | 7024 | 7033 | 7042 | 7050 | 7059 | 7067 | 1 | 2 | 3 | 3 | 4 | 5 | 6 | 7 | 8 |
| 51 | 7076 | 7084 | 7093 | 7101 | 7110 | 7118 | 7126 | 7135 | 7143 | 7152 | 1 | 2 | 3 | 3 | 4 | 5 | 6 | 7 | 8 |
| 52 | 7160 | 7168 | 7177 | 7185 | 7193 | 7202 | 7210 | 7218 | 7226 | 7235 | 1 | 2 | 2 | 3 | 4 | 5 | 6 | 7 | 7 |
| 53 | 7243 | 7251 | 7259 | 7267 | 7275 | 7284 | 7292 | 7300 | 7308 | 7316 | 1 | 2 | 2 | 3 | 4 | 5 | 6 | 6 | 7 |
| 54 | 7324 | 7332 | 7340 | 7348 | 7356 | 7364 | 7372 | 7380 | 7388 | 7396 | 1 | 2 | 2 | 3 | 4 | 5 | 6 | 6 | 7 |

| | 0 | 1 | 2 | 3 | 4 | 5 | 6 | 7 | 8 | 9 | 1 | 2 | 3 | 4 | 5 | 6 | 7 | 8 | 9 |
|----|------|------|------|------|------|------|------|------|------|------|---|---|---|---|---|---|---|---|---|
| 55 | 7404 | 7412 | 7419 | 7427 | 7435 | 7443 | 7451 | 7459 | 7466 | 7474 | 1 | 2 | 2 | 3 | 4 | 5 | 5 | 6 | 7 |
| 56 | 7482 | 7490 | 7497 | 7505 | 7513 | 7520 | 7528 | 7536 | 7543 | 7551 | 1 | 2 | 2 | 3 | 4 | 5 | 5 | 6 | 7 |
| 57 | 7559 | 7566 | 7574 | 7582 | 7589 | 7597 | 7604 | 7612 | 7619 | 7627 | 1 | 2 | 2 | 3 | 4 | 5 | 5 | 6 | 7 |
| 58 | 7634 | 7642 | 7649 | 7657 | 7664 | 7672 | 7679 | 7686 | 7694 | 7701 | 1 | 1 | 2 | 3 | 4 | 4 | 5 | 6 | 7 |
| 59 | 7709 | 7716 | 7723 | 7731 | 7738 | 7745 | 7752 | 7760 | 7767 | 7774 | 1 | 1 | 2 | 3 | 4 | 4 | 5 | 6 | 7 |
| 60 | 7782 | 7789 | 7796 | 7803 | 7810 | 7818 | 7825 | 7832 | 7839 | 7846 | 1 | 1 | 2 | 3 | 4 | 4 | 5 | 6 | 7 |
| 61 | 7853 | 7860 | 7868 | 7875 | 7882 | 7889 | 7896 | 7903 | 7910 | 7917 | 1 | 1 | 2 | 3 | 4 | 4 | 5 | 6 | 6 |
| 62 | 7924 | 7931 | 7938 | 7945 | 7952 | 7959 | 7966 | 7973 | 7980 | 7987 | 1 | 1 | 2 | 3 | 3 | 4 | 5 | 6 | 6 |
| 63 | 7993 | 8000 | 8007 | 8014 | 8021 | 8028 | 8035 | 8041 | 8048 | 8055 | 1 | 1 | 2 | 3 | 3 | 4 | 5 | 5 | 6 |
| 64 | 8062 | 8069 | 8075 | 8082 | 8089 | 8096 | 8102 | 8109 | 8116 | 8122 | 1 | 1 | 2 | 3 | 3 | 4 | 5 | 5 | 6 |
| 65 | 8129 | 8136 | 8142 | 8149 | 8156 | 8162 | 8169 | 8176 | 8182 | 8189 | 1 | 1 | 2 | 3 | 3 | 4 | 5 | 5 | 6 |
| 66 | 8195 | 8202 | 8209 | 8215 | 8222 | 8228 | 8235 | 8241 | 8248 | 8254 | 1 | 1 | 2 | 3 | 3 | 4 | 5 | 5 | 6 |
| 67 | 8261 | 8267 | 8274 | 8280 | 8287 | 8293 | 8299 | 8306 | 8312 | 8319 | 1 | 1 | 2 | 3 | 3 | 4 | 5 | 5 | 6 |
| 68 | 8325 | 8331 | 8338 | 8344 | 8351 | 8357 | 8363 | 8370 | 8376 | 8382 | 1 | 1 | 2 | 3 | 3 | 4 | 4 | 5 | 6 |
| 69 | 8388 | 8395 | 8401 | 8407 | 8414 | 8420 | 8426 | 8432 | 8439 | 8445 | 1 | 1 | 2 | 2 | 3 | 4 | 4 | 5 | 6 |
| 70 | 8451 | 8457 | 8463 | 8470 | 8476 | 8482 | 8488 | 8494 | 8500 | 8506 | 1 | 1 | 2 | 2 | 3 | 4 | 4 | 5 | 6 |
| 71 | 8513 | 8519 | 8525 | 8531 | 8537 | 8543 | 8549 | 8555 | 8561 | 8567 | 1 | 1 | 2 | 2 | 3 | 4 | 4 | 5 | 5 |
| 72 | 8573 | 8579 | 8585 | 8591 | 8597 | 8603 | 8609 | 8615 | 8621 | 8627 | 1 | 1 | 2 | 2 | 3 | 4 | 4 | 5 | 5 |
| 73 | 8633 | 8639 | 8645 | 8651 | 8657 | 8663 | 8669 | 8675 | 8681 | 8686 | 1 | 1 | 2 | 2 | 3 | 4 | 4 | 5 | 5 |
| 74 | 8692 | 8698 | 8704 | 8710 | 8716 | 8722 | 8727 | 8733 | 8739 | 8745 | 1 | 1 | 2 | 2 | 3 | 4 | 4 | 5 | 5 |
| 75 | 8751 | 8756 | 8762 | 8768 | 8774 | 8779 | 8785 | 8791 | 8797 | 8802 | 1 | 1 | 2 | 2 | 3 | 3 | 4 | 5 | 5 |
| 76 | 8808 | 8814 | 8820 | 8825 | 8831 | 8837 | 8842 | 8848 | 8854 | 8859 | 1 | 1 | 2 | 2 | 3 | 3 | 4 | 5 | 5 |
| 77 | 8865 | 8871 | 8876 | 8882 | 8887 | 8893 | 8899 | 8904 | 8910 | 8915 | 1 | 1 | 2 | 2 | 3 | 3 | 4 | 4 | 5 |
| 78 | 8921 | 8927 | 8932 | 8938 | 8943 | 8949 | 8954 | 8960 | 8965 | 8971 | 1 | 1 | 2 | 2 | 3 | 3 | 4 | 4 | 5 |
| 79 | 8976 | 8982 | 8987 | 8993 | 8998 | 9004 | 9009 | 9015 | 9020 | 9025 | 1 | 1 | 2 | 2 | 3 | 3 | 4 | 4 | 5 |
| 80 | 9031 | 9036 | 9042 | 9047 | 9053 | 9058 | 9063 | 9069 | 9074 | 9079 | 1 | 1 | 2 | 2 | 3 | 3 | 4 | 4 | 5 |
| 81 | 9085 | 9090 | 9096 | 9101 | 9106 | 9112 | 9117 | 9122 | 9128 | 9133 | 1 | 1 | 2 | 2 | 3 | 3 | 4 | 4 | 5 |
| 82 | 9138 | 9143 | 9149 | 9154 | 9159 | 9165 | 9170 | 9175 | 9180 | 9186 | 1 | 1 | 2 | 2 | 3 | 3 | 4 | 4 | 5 |
| 83 | 9191 | 9196 | 9201 | 9206 | 9212 | 9217 | 9222 | 9227 | 9232 | 9238 | 1 | 1 | 2 | 2 | 3 | 3 | 4 | 4 | 5 |
| 84 | 9243 | 9248 | 9253 | 9258 | 9263 | 9269 | 9274 | 9279 | 9284 | 9289 | 1 | 1 | 2 | 2 | 3 | 3 | 4 | 4 | 5 |
| 85 | 9294 | 9299 | 9304 | 9309 | 9315 | 9320 | 9325 | 9330 | 9335 | 9340 | 1 | 1 | 2 | 2 | 3 | 3 | 4 | 4 | 5 |
| 86 | 9345 | 9350 | 9355 | 9360 | 9365 | 9370 | 9375 | 9380 | 9385 | 9390 | 1 | 1 | 2 | 2 | 3 | 3 | 4 | 4 | 5 |
| 87 | 9395 | 9400 | 9405 | 9410 | 9415 | 9420 | 9425 | 9430 | 9435 | 9440 | 0 | 1 | 1 | 2 | 2 | 3 | 3 | 4 | 4 |
| 88 | 9445 | 9450 | 9455 | 9460 | 9465 | 9469 | 9474 | 9479 | 9484 | 9489 | 0 | 1 | 1 | 2 | 2 | 3 | 3 | 4 | 4 |
| 89 | 9494 | 9499 | 9504 | 9509 | 9513 | 9518 | 9523 | 9528 | 9533 | 9538 | 0 | 1 | 1 | 2 | 2 | 3 | 3 | 4 | 4 |
| 90 | 9542 | 9547 | 9552 | 9557 | 9562 | 9566 | 9571 | 9576 | 9581 | 9586 | 0 | 1 | 1 | 2 | 2 | 3 | 3 | 4 | 4 |
| 91 | 9590 | 9595 | 9600 | 9605 | 9609 | 9614 | 9619 | 9624 | 9628 | 9633 | 0 | 1 | 1 | 2 | 2 | 3 | 3 | 4 | 4 |
| 92 | 9638 | 9643 | 9647 | 9652 | 9657 | 9661 | 9666 | 9671 | 9675 | 9680 | 0 | 1 | 1 | 2 | 2 | 3 | 3 | 4 | 4 |
| 93 | 9685 | 9689 | 9694 | 9699 | 9703 | 9708 | 9713 | 9717 | 9722 | 9727 | 0 | 1 | 1 | 2 | 2 | 3 | 3 | 4 | 4 |
| 94 | 9731 | 9736 | 9741 | 9745 | 9750 | 9754 | 9759 | 9763 | 9768 | 9773 | 0 | 1 | 1 | 2 | 2 | 3 | 3 | 4 | 4 |
| 95 | 9777 | 9782 | 9786 | 9791 | 9795 | 9800 | 9805 | 9809 | 9814 | 9818 | 0 | 1 | 1 | 2 | 2 | 3 | 3 | 4 | 4 |
| 96 | 9823 | 9827 | 9832 | 9836 | 9841 | 9845 | 9850 | 9854 | 9859 | 9863 | 0 | 1 | 1 | 2 | 2 | 3 | 3 | 4 | 4 |
| 97 | 9868 | 9872 | 9877 | 9881 | 9886 | 9890 | 9894 | 9899 | 9903 | 9908 | 0 | 1 | 1 | 2 | 2 | 3 | 3 | 4 | 4 |
| 98 | 9912 | 9917 | 9921 | 9926 | 9930 | 9934 | 9939 | 9943 | 9948 | 9952 | 0 | 1 | 1 | 2 | 2 | 3 | 3 | 4 | 4 |
| 99 | 9956 | 9961 | 9965 | 9969 | 9974 | 9978 | 9983 | 9987 | 9991 | 9996 | 0 | 1 | 1 | 2 | 2 | 3 | 3 | 4 | 4 |

| | 0' | 6' | 12' | 18' | 24' | 30' | 36' | 42' | 48' | 54' | 1 | 2 | 3 | 4 | 5 |
|----|------|------|------|------|------|------|------|------|------|------|---|---|---|----|----|
| 0° | 0000 | 0017 | 0035 | 0052 | 0070 | 0087 | 0105 | 0122 | 0140 | 0157 | 3 | 6 | 9 | 12 | 15 |
| 1 | 0175 | 0192 | 0209 | 0227 | 0244 | 0262 | 0279 | 0297 | 0314 | 0332 | 3 | 6 | 9 | 12 | 15 |
| 2 | 0349 | 0366 | 0384 | 0401 | 0419 | 0436 | 0454 | 0471 | 0488 | 0506 | 3 | 6 | 9 | 12 | 15 |
| 3 | 0523 | 0541 | 0558 | 0576 | 0593 | 0610 | 0628 | 0645 | 0663 | 0680 | 3 | 6 | 9 | 12 | 15 |
| 4 | 0698 | 0715 | 0732 | 0750 | 0767 | 0785 | 0802 | 0819 | 0837 | 0854 | 3 | 6 | 9 | 12 | 15 |
| 5 | 0872 | 0889 | 0906 | 0924 | 0941 | 0958 | 0976 | 0993 | 1011 | 1028 | 3 | 6 | 9 | 12 | 14 |
| 6 | 1045 | 1063 | 1080 | 1097 | 1115 | 1132 | 1149 | 1167 | 1184 | 1201 | 3 | 6 | 9 | 12 | 14 |
| 7 | 1219 | 1236 | 1253 | 1271 | 1288 | 1305 | 1323 | 1340 | 1357 | 1374 | 3 | 6 | 9 | 12 | 14 |
| 8 | 1392 | 1409 | 1426 | 1444 | 1461 | 1478 | 1495 | 1513 | 1530 | 1547 | 3 | 6 | 9 | 12 | 14 |
| 9 | 1564 | 1582 | 1599 | 1616 | 1633 | 1650 | 1668 | 1685 | 1702 | 1719 | 3 | 6 | 9 | 12 | 14 |
| 10 | 1736 | 1754 | 1771 | 1788 | 1805 | 1822 | 1840 | 1857 | 1874 | 1891 | 3 | 6 | 9 | 12 | 14 |
| 11 | 1908 | 1925 | 1942 | 1959 | 1977 | 1994 | 2011 | 2028 | 2045 | 2062 | 3 | 6 | 9 | 11 | 14 |
| 12 | 2079 | 2096 | 2113 | 2130 | 2147 | 2164 | 2181 | 2198 | 2215 | 2232 | 3 | 6 | 9 | 11 | 14 |
| 13 | 2250 | 2267 | 2284 | 2300 | 2317 | 2334 | 2351 | 2368 | 2385 | 2402 | 3 | 6 | 8 | 11 | 14 |
| 14 | 2419 | 2436 | 2453 | 2470 | 2487 | 2504 | 2521 | 2538 | 2554 | 2571 | 3 | 6 | 8 | 11 | 14 |
| 15 | 2588 | 2605 | 2622 | 2639 | 2656 | 2672 | 2689 | 2706 | 2723 | 2740 | 3 | 6 | 8 | 11 | 14 |
| 16 | 2756 | 2773 | 2790 | 2807 | 2823 | 2840 | 2857 | 2874 | 2890 | 2907 | 3 | 6 | 8 | 11 | 14 |
| 17 | 2924 | 2940 | 2957 | 2974 | 2990 | 3007 | 3024 | 3040 | 3057 | 3074 | 3 | 6 | 8 | 11 | 14 |
| 18 | 3090 | 3107 | 3123 | 3140 | 3156 | 3173 | 3190 | 3206 | 3223 | 3239 | 3 | 6 | 8 | 11 | 14 |
| 19 | 3256 | 3272 | 3289 | 3305 | 3322 | 3338 | 3355 | 3371 | 3387 | 3404 | 3 | 5 | 8 | 11 | 14 |
| 20 | 3420 | 3437 | 3453 | 3469 | 3486 | 3502 | 3518 | 3535 | 3551 | 3567 | 3 | 5 | 8 | 11 | 14 |
| 21 | 3584 | 3600 | 3616 | 3633 | 3649 | 3665 | 3681 | 3697 | 3714 | 3730 | 3 | 5 | 8 | 11 | 14 |
| 22 | 3746 | 3762 | 3778 | 3795 | 3811 | 3827 | 3843 | 3859 | 3875 | 3891 | 3 | 5 | 8 | 11 | 14 |
| 23 | 3907 | 3923 | 3939 | 3955 | 3971 | 3987 | 4003 | 4019 | 4035 | 4051 | 3 | 5 | 8 | 11 | 14 |
| 24 | 4067 | 4083 | 4099 | 4115 | 4131 | 4147 | 4163 | 4179 | 4195 | 4210 | 3 | 5 | 8 | 11 | 13 |
| 25 | 4226 | 4242 | 4258 | 4274 | 4289 | 4305 | 4321 | 4337 | 4352 | 4368 | 3 | 5 | 8 | 11 | 13 |
| 26 | 4384 | 4399 | 4415 | 4431 | 4446 | 4462 | 4478 | 4493 | 4509 | 4524 | 3 | 5 | 8 | 10 | 13 |
| 27 | 4540 | 4555 | 4571 | 4586 | 4602 | 4617 | 4633 | 4648 | 4664 | 4679 | 3 | 5 | 8 | 10 | 13 |
| 28 | 4695 | 4710 | 4726 | 4741 | 4756 | 4772 | 4787 | 4802 | 4818 | 4833 | 3 | 5 | 8 | 10 | 13 |
| 29 | 4848 | 4863 | 4879 | 4894 | 4909 | 4924 | 4939 | 4955 | 4970 | 4985 | 3 | 5 | 8 | 10 | 13 |
| 30 | 5000 | 5015 | 5030 | 5045 | 5060 | 5075 | 5090 | 5105 | 5120 | 5135 | 3 | 5 | 8 | 10 | 13 |
| 31 | 5150 | 5165 | 5180 | 5195 | 5210 | 5225 | 5240 | 5255 | 5270 | 5284 | 2 | 5 | 7 | 10 | 12 |
| 32 | 5299 | 5314 | 5329 | 5344 | 5358 | 5373 | 5388 | 5402 | 5417 | 5432 | 2 | 5 | 7 | 10 | 12 |
| 33 | 5440 | 5461 | 5476 | 5490 | 5505 | 5519 | 5534 | 5548 | 5563 | 5577 | 2 | 5 | 7 | 10 | 12 |
| 34 | 5592 | 5606 | 5621 | 5635 | 5650 | 5664 | 5678 | 5693 | 5707 | 5721 | 2 | 5 | 7 | 10 | 12 |
| 35 | 5736 | 5750 | 5764 | 5779 | 5793 | 5807 | 5821 | 5835 | 5850 | 5864 | 2 | 5 | 7 | 10 | 12 |
| 36 | 5878 | 5892 | 5906 | 5920 | 5934 | 5948 | 5962 | 5976 | 5990 | 6004 | 2 | 5 | 7 | 9 | 12 |
| 37 | 6018 | 6032 | 6046 | 6060 | 6074 | 6088 | 6101 | 6115 | 6129 | 6143 | 2 | 5 | 7 | 9 | 12 |
| 38 | 6157 | 6170 | 6184 | 6198 | 6211 | 6225 | 6239 | 6252 | 6266 | 6280 | 2 | 5 | 7 | 9 | 11 |
| 39 | 6293 | 6307 | 6320 | 6334 | 6347 | 6361 | 6374 | 6388 | 6401 | 6414 | 2 | 4 | 7 | 9 | 11 |
| 40 | 6428 | 6441 | 6455 | 6468 | 6481 | 6494 | 6508 | 6521 | 6534 | 6547 | 2 | 4 | 7 | 9 | 11 |
| 41 | 6561 | 6574 | 6587 | 6600 | 6613 | 6626 | 6639 | 6652 | 6665 | 6678 | 2 | 4 | 7 | 9 | 11 |
| 42 | 6691 | 6704 | 6717 | 6730 | 6743 | 6756 | 6769 | 6782 | 6794 | 6807 | 2 | 4 | 6 | 9 | 11 |
| 43 | 6820 | 6833 | 6845 | 6858 | 6871 | 6884 | 6896 | 6909 | 6921 | 6934 | 2 | 4 | 6 | 8 | 11 |
| 44 | 6947 | 6959 | 6972 | 6984 | 6997 | 7009 | 7022 | 7034 | 7046 | 7059 | 2 | 4 | 6 | 8 | 10 |

NATURAL SINES.

| | 0' | 6' | 12' | 18' | 24' | 30' | 36' | 42' | 48' | 54' | 1 | 2 | 3 | 4 | 5 |
|-----|------|------|------|------|------|------------------|------------------|------------------|------------------|------------------|---|---|---|---|----|
| 45° | 7071 | 7083 | 7096 | 7108 | 7120 | 7133 | 7145 | 7157 | 7169 | 7181 | 2 | 4 | 6 | 8 | 10 |
| 46 | 7193 | 7206 | 7218 | 7230 | 7242 | 7254 | 7266 | 7278 | 7290 | 7302 | 2 | 4 | 6 | 8 | 10 |
| 47 | 7314 | 7325 | 7337 | 7349 | 7361 | 7373 | 7385 | 7396 | 7408 | 7420 | 2 | 4 | 6 | 8 | 10 |
| 48 | 7431 | 7443 | 7455 | 7466 | 7478 | 7490 | 7501 | 7513 | 7524 | 7536 | 2 | 4 | 6 | 8 | 10 |
| 49 | 7547 | 7558 | 7570 | 7581 | 7593 | 7604 | 7615 | 7627 | 7638 | 7649 | 2 | 4 | 6 | 8 | 9 |
| 50 | 7660 | 7672 | 7683 | 7694 | 7705 | 7716 | 7727 | 7738 | 7749 | 7760 | 2 | 4 | 6 | 7 | 9 |
| 51 | 7771 | 7782 | 7793 | 7804 | 7815 | 7826 | 7837 | 7848 | 7859 | 7869 | 2 | 4 | 5 | 7 | 9 |
| 52 | 7880 | 7891 | 7902 | 7912 | 7923 | 7934 | 7944 | 7955 | 7965 | 7976 | 2 | 4 | 5 | 7 | 9 |
| 53 | 7986 | 7997 | 8007 | 8018 | 8028 | 8039 | 8049 | 8059 | 8070 | 8080 | 2 | 3 | 5 | 7 | 9 |
| 54 | 8090 | 8100 | 8111 | 8121 | 8131 | 8141 | 8151 | 8161 | 8171 | 8181 | 2 | 3 | 5 | 7 | 8 |
| 55 | 8192 | 8202 | 8211 | 8221 | 8231 | 8241 | 8251 | 8261 | 8271 | 8281 | 2 | 3 | 5 | 7 | 8 |
| 56 | 8290 | 8300 | 8310 | 8320 | 8329 | 8339 | 8348 | 8358 | 8368 | 8377 | 2 | 3 | 5 | 6 | 8 |
| 57 | 8387 | 8396 | 8406 | 8415 | 8425 | 8434 | 8443 | 8453 | 8462 | 8471 | 2 | 3 | 5 | 6 | 8 |
| 58 | 8480 | 8490 | 8499 | 8508 | 8517 | 8526 | 8536 | 8545 | 8554 | 8563 | 2 | 3 | 5 | 6 | 8 |
| 59 | 8572 | 8581 | 8590 | 8599 | 8607 | 8616 | 8625 | 8634 | 8643 | 8652 | 1 | 3 | 4 | 6 | 7 |
| 60 | 8660 | 8669 | 8678 | 8686 | 8695 | 8704 | 8712 | 8721 | 8729 | 8738 | 1 | 3 | 4 | 6 | 7 |
| 61 | 8746 | 8755 | 8763 | 8771 | 8780 | 8788 | 8796 | 8805 | 8813 | 8821 | 1 | 3 | 4 | 6 | 7 |
| 62 | 8829 | 8838 | 8846 | 8854 | 8862 | 8870 | 8878 | 8886 | 8894 | 8902 | 1 | 3 | 4 | 5 | 7 |
| 63 | 8910 | 8918 | 8926 | 8934 | 8942 | 8949 | 8957 | 8965 | 8973 | 8980 | 1 | 3 | 4 | 5 | 6 |
| 64 | 8988 | 8996 | 9003 | 9011 | 9018 | 9026 | 9033 | 9041 | 9048 | 9056 | 1 | 3 | 4 | 5 | 6 |
| 65 | 9063 | 9070 | 9078 | 9085 | 9092 | 9100 | 9107 | 9114 | 9121 | 9128 | 1 | 2 | 4 | 5 | 6 |
| 66 | 9135 | 9143 | 9150 | 9157 | 9164 | 9171 | 9178 | 9184 | 9191 | 9198 | 1 | 2 | 3 | 5 | 6 |
| 67 | 9205 | 9212 | 9219 | 9225 | 9232 | 9239 | 9245 | 9252 | 9259 | 9265 | 1 | 2 | 3 | 4 | 6 |
| 68 | 9272 | 9278 | 9285 | 9291 | 9298 | 9304 | 9311 | 9317 | 9323 | 9330 | 1 | 2 | 3 | 4 | 5 |
| 69 | 9336 | 9342 | 9348 | 9354 | 9361 | 9367 | 9373 | 9379 | 9385 | 9391 | 1 | 2 | 3 | 4 | 5 |
| 70 | 9397 | 9403 | 9409 | 9415 | 9421 | 9426 | 9432 | 9438 | 9444 | 9449 | 1 | 2 | 3 | 4 | 5 |
| 71 | 9455 | 9461 | 9466 | 9472 | 9478 | 9483 | 9489 | 9494 | 9500 | 9505 | 1 | 2 | 3 | 4 | 5 |
| 72 | 9511 | 9516 | 9521 | 9527 | 9532 | 9537 | 9542 | 9548 | 9553 | 9558 | 1 | 2 | 3 | 4 | 4 |
| 73 | 9563 | 9568 | 9573 | 9578 | 9583 | 9588 | 9593 | 9598 | 9603 | 9608 | 1 | 2 | 2 | 3 | 4 |
| 74 | 9613 | 9617 | 9622 | 9627 | 9632 | 9636 | 9641 | 9646 | 9650 | 9655 | 1 | 2 | 2 | 3 | 4 |
| 75 | 9659 | 9664 | 9668 | 9673 | 9677 | 9681 | 9686 | 9690 | 9694 | 9699 | 1 | 1 | 2 | 3 | 4 |
| 76 | 9703 | 9707 | 9711 | 9715 | 9720 | 9724 | 9728 | 9732 | 9736 | 9740 | 1 | 1 | 2 | 3 | 3 |
| 77 | 9744 | 9748 | 9751 | 9755 | 9759 | 9763 | 9767 | 9770 | 9774 | 9778 | 1 | 1 | 2 | 3 | 3 |
| 78 | 9781 | 9785 | 9789 | 9792 | 9796 | 9799 | 9803 | 9806 | 9810 | 9813 | 1 | 1 | 2 | 2 | 3 |
| 79 | 9816 | 9820 | 9823 | 9826 | 9829 | 9833 | 9836 | 9839 | 9842 | 9845 | 1 | 1 | 2 | 2 | 3 |
| 80 | 9848 | 9851 | 9854 | 9857 | 9860 | 9863 | 9866 | 9869 | 9871 | 9874 | 0 | 1 | 1 | 2 | 2 |
| 81 | 9877 | 9880 | 9882 | 9885 | 9888 | 9890 | 9893 | 9895 | 9898 | 9900 | 0 | 1 | 1 | 2 | 2 |
| 82 | 9903 | 9905 | 9907 | 9910 | 9912 | 9914 | 9917 | 9919 | 9921 | 9923 | 0 | 1 | 1 | 2 | 2 |
| 83 | 9925 | 9928 | 9930 | 9932 | 9934 | 9936 | 9938 | 9940 | 9942 | 9943 | 0 | 1 | 1 | 1 | 2 |
| 84 | 9945 | 9947 | 9949 | 9951 | 9952 | 9954 | 9956 | 9957 | 9959 | 9960 | 0 | 1 | 1 | 1 | 1 |
| 85 | 9962 | 9963 | 9965 | 9966 | 9968 | 9969 | 9971 | 9972 | 9973 | 9974 | 0 | 0 | 1 | 1 | 1 |
| 86 | 9976 | 9977 | 9978 | 9979 | 9980 | 9981 | 9982 | 9983 | 9984 | 9985 | 0 | 0 | 1 | 1 | 1 |
| 87 | 9986 | 9987 | 9988 | 9989 | 9990 | 9990 | 9991 | 9992 | 9993 | 9993 | 0 | 0 | 0 | 1 | 1 |
| 88 | 9994 | 9995 | 9995 | 9996 | 9996 | 9997 | 9997 | 9997 | 9998 | 9998 | 0 | 0 | 0 | 0 | 0 |
| 89 | 9998 | 9999 | 9999 | 9999 | 9999 | 1'000 nearly. | 1'000 nearly. | 1'000 nearly. | 1'000 nearly. | 1'000 nearly. | 0 | 0 | 0 | 0 | 0 |

NATURAL COSINES.

| | 0' | 6' | 12' | 18' | 24' | 30' | 36' | 42' | 48' | 54' | 1 | 2 | 3 | 4 | 5 |
|----|-------|------------------|------------------|------------------|------------------|------|------|------|------|------|---|---|---|---|----|
| 0° | 1'000 | 1'000 nearly. | 1'000 nearly. | 1'000 nearly. | 1'000 nearly. | 9999 | 9999 | 9999 | 9999 | 9999 | 0 | 0 | 0 | 0 | 0 |
| 1 | 9998 | 9998 | 9998 | 9997 | 9997 | 9997 | 9996 | 9996 | 9995 | 9995 | 0 | 0 | 0 | 0 | 0 |
| 2 | 9994 | 9993 | 9993 | 9992 | 9991 | 9990 | 9990 | 9989 | 9988 | 9987 | 0 | 0 | 0 | 1 | 1 |
| 3 | 9986 | 9985 | 9984 | 9983 | 9982 | 9981 | 9980 | 9979 | 9978 | 9977 | 0 | 0 | 1 | 1 | 1 |
| 4 | 9976 | 9974 | 9973 | 9972 | 9971 | 9969 | 9968 | 9966 | 9965 | 9963 | 0 | 0 | 1 | 1 | 1 |
| 5 | 9962 | 9960 | 9959 | 9957 | 9956 | 9954 | 9952 | 9951 | 9949 | 9947 | 0 | 1 | 1 | 1 | 2 |
| 6 | 9945 | 9943 | 9942 | 9940 | 9938 | 9936 | 9934 | 9932 | 9930 | 9928 | 0 | 1 | 1 | 1 | 2 |
| 7 | 9925 | 9923 | 9921 | 9919 | 9917 | 9914 | 9912 | 9910 | 9907 | 9905 | 0 | 1 | 1 | 2 | 2 |
| 8 | 9903 | 9900 | 9898 | 9895 | 9893 | 9890 | 9888 | 9885 | 9882 | 9880 | 0 | 1 | 1 | 2 | 2 |
| 9 | 9877 | 9874 | 9871 | 9869 | 9866 | 9863 | 9860 | 9857 | 9854 | 9851 | 0 | 1 | 1 | 2 | 2 |
| 10 | 9848 | 9845 | 9842 | 9839 | 9836 | 9833 | 9829 | 9826 | 9823 | 9820 | 1 | 1 | 2 | 2 | 3 |
| 11 | 9816 | 9813 | 9810 | 9806 | 9803 | 9799 | 9796 | 9792 | 9789 | 9785 | 1 | 1 | 2 | 2 | 3 |
| 12 | 9781 | 9778 | 9774 | 9770 | 9767 | 9763 | 9759 | 9755 | 9751 | 9748 | 1 | 1 | 2 | 3 | 3 |
| 13 | 9744 | 9740 | 9736 | 9732 | 9728 | 9724 | 9720 | 9715 | 9711 | 9707 | 1 | 1 | 2 | 3 | 3 |
| 14 | 9703 | 9699 | 9694 | 9690 | 9686 | 9681 | 9677 | 9673 | 9668 | 9664 | 1 | 1 | 2 | 3 | 4 |
| 15 | 9659 | 9655 | 9650 | 9646 | 9641 | 9636 | 9632 | 9627 | 9622 | 9617 | 1 | 2 | 2 | 3 | 4 |
| 16 | 9613 | 9608 | 9603 | 9598 | 9593 | 9588 | 9583 | 9578 | 9573 | 9568 | 1 | 2 | 2 | 3 | 4 |
| 17 | 9563 | 9558 | 9553 | 9548 | 9542 | 9537 | 9532 | 9527 | 9521 | 9516 | 1 | 2 | 3 | 4 | 4 |
| 18 | 9511 | 9505 | 9500 | 9494 | 9489 | 9483 | 9478 | 9472 | 9466 | 9461 | 1 | 2 | 3 | 4 | 5 |
| 19 | 9455 | 9449 | 9444 | 9438 | 9432 | 9426 | 9421 | 9415 | 9409 | 9403 | 1 | 2 | 3 | 4 | 5 |
| 20 | 9397 | 9391 | 9385 | 9379 | 9373 | 9367 | 9361 | 9354 | 9348 | 9342 | 1 | 2 | 3 | 4 | 5 |
| 21 | 9336 | 9330 | 9323 | 9317 | 9311 | 9304 | 9298 | 9291 | 9285 | 9278 | 1 | 2 | 3 | 4 | 5 |
| 22 | 9272 | 9265 | 9259 | 9252 | 9245 | 9239 | 9232 | 9225 | 9219 | 9212 | 1 | 2 | 3 | 4 | 6 |
| 23 | 9205 | 9198 | 9191 | 9184 | 9178 | 9171 | 9164 | 9157 | 9150 | 9143 | 1 | 2 | 3 | 5 | 6 |
| 24 | 9135 | 9128 | 9121 | 9114 | 9107 | 9100 | 9092 | 9085 | 9078 | 9070 | 1 | 2 | 4 | 5 | 6 |
| 25 | 9063 | 9056 | 9048 | 9041 | 9033 | 9026 | 9018 | 9011 | 9003 | 8996 | 1 | 3 | 4 | 5 | 6 |
| 26 | 8988 | 8980 | 8973 | 8965 | 8957 | 8949 | 8942 | 8934 | 8926 | 8918 | 1 | 3 | 4 | 5 | 6 |
| 27 | 8910 | 8902 | 8894 | 8886 | 8878 | 8870 | 8862 | 8854 | 8846 | 8838 | 1 | 3 | 4 | 5 | 7 |
| 28 | 8829 | 8821 | 8813 | 8805 | 8796 | 8788 | 8780 | 8771 | 8763 | 8755 | 1 | 3 | 4 | 6 | 7 |
| 29 | 8746 | 8738 | 8729 | 8721 | 8712 | 8704 | 8695 | 8686 | 8678 | 8669 | 1 | 3 | 4 | 6 | 7 |
| 30 | 8600 | 8592 | 8583 | 8574 | 8565 | 8556 | 8547 | 8538 | 8529 | 8520 | 1 | 3 | 4 | 6 | 7 |
| 31 | 8572 | 8563 | 8554 | 8545 | 8536 | 8526 | 8517 | 8508 | 8499 | 8490 | 2 | 3 | 5 | 6 | 8 |
| 32 | 8480 | 8471 | 8462 | 8453 | 8443 | 8434 | 8425 | 8415 | 8406 | 8396 | 2 | 3 | 5 | 6 | 8 |
| 33 | 8387 | 8377 | 8368 | 8358 | 8348 | 8339 | 8329 | 8320 | 8310 | 8300 | 2 | 3 | 5 | 6 | 8 |
| 34 | 8290 | 8281 | 8271 | 8261 | 8251 | 8241 | 8231 | 8221 | 8211 | 8202 | 2 | 3 | 5 | 7 | 8 |
| 35 | 8192 | 8181 | 8171 | 8161 | 8151 | 8141 | 8131 | 8121 | 8111 | 8100 | 2 | 3 | 5 | 7 | 8 |
| 36 | 8090 | 8080 | 8070 | 8059 | 8049 | 8039 | 8028 | 8018 | 8007 | 7997 | 2 | 3 | 5 | 7 | 9 |
| 37 | 7986 | 7976 | 7965 | 7955 | 7944 | 7934 | 7923 | 7912 | 7902 | 7891 | 2 | 4 | 5 | 7 | 9 |
| 38 | 7880 | 7869 | 7859 | 7848 | 7837 | 7826 | 7815 | 7804 | 7793 | 7782 | 2 | 4 | 5 | 7 | 9 |
| 39 | 7771 | 7760 | 7749 | 7738 | 7727 | 7716 | 7705 | 7694 | 7683 | 7672 | 2 | 4 | 6 | 7 | 9 |
| 40 | 7660 | 7649 | 7638 | 7627 | 7615 | 7604 | 7593 | 7581 | 7570 | 7559 | 2 | 4 | 6 | 8 | 9 |
| 41 | 7547 | 7536 | 7524 | 7513 | 7501 | 7490 | 7478 | 7466 | 7455 | 7443 | 2 | 4 | 6 | 8 | 10 |
| 42 | 7431 | 7420 | 7408 | 7396 | 7385 | 7373 | 7361 | 7349 | 7337 | 7325 | 2 | 4 | 6 | 8 | 10 |
| 43 | 7314 | 7302 | 7290 | 7278 | 7266 | 7254 | 7242 | 7230 | 7218 | 7206 | 2 | 4 | 6 | 8 | 10 |
| 44 | 7193 | 7181 | 7169 | 7157 | 7145 | 7133 | 7120 | 7108 | 7096 | 7083 | 2 | 4 | 6 | 8 | 10 |

N.B.—Numbers in difference-columns to be subtracted, not added.

| | 0' | 6' | 12' | 18' | 24' | 30' | 36' | 42' | 48' | 54' | 1 | 2 | 3 | 4 | 5 |
|-----|------|------|------|------|------|------|------|------|------|------|---|---|---|----|----|
| 45° | 7071 | 7059 | 7046 | 7034 | 7022 | 7009 | 6997 | 6984 | 6972 | 6959 | 2 | 4 | 6 | 8 | 10 |
| 46 | 6947 | 6934 | 6921 | 6909 | 6896 | 6884 | 6871 | 6858 | 6845 | 6833 | 2 | 4 | 6 | 8 | 11 |
| 47 | 6820 | 6807 | 6794 | 6782 | 6769 | 6756 | 6743 | 6730 | 6717 | 6704 | 2 | 4 | 6 | 9 | 11 |
| 48 | 6691 | 6678 | 6665 | 6652 | 6639 | 6626 | 6613 | 6600 | 6587 | 6574 | 2 | 4 | 7 | 9 | 11 |
| 49 | 6561 | 6547 | 6534 | 6521 | 6508 | 6494 | 6481 | 6468 | 6455 | 6441 | 2 | 4 | 7 | 9 | 11 |
| 50 | 6428 | 6414 | 6401 | 6388 | 6374 | 6361 | 6347 | 6334 | 6320 | 6307 | 2 | 4 | 7 | 9 | 11 |
| 51 | 6293 | 6280 | 6266 | 6252 | 6239 | 6225 | 6211 | 6198 | 6184 | 6170 | 2 | 5 | 7 | 9 | 11 |
| 52 | 6157 | 6143 | 6129 | 6115 | 6101 | 6088 | 6074 | 6060 | 6046 | 6032 | 2 | 5 | 7 | 9 | 12 |
| 53 | 6018 | 6004 | 5990 | 5976 | 5962 | 5948 | 5934 | 5920 | 5906 | 5892 | 2 | 5 | 7 | 9 | 12 |
| 54 | 5878 | 5864 | 5850 | 5835 | 5821 | 5807 | 5793 | 5779 | 5764 | 5750 | 2 | 5 | 7 | 9 | 12 |
| 55 | 5736 | 5721 | 5707 | 5693 | 5678 | 5664 | 5650 | 5635 | 5621 | 5606 | 2 | 5 | 7 | 10 | 12 |
| 56 | 5592 | 5577 | 5563 | 5548 | 5534 | 5519 | 5505 | 5490 | 5476 | 5461 | 2 | 5 | 7 | 10 | 12 |
| 57 | 5446 | 5432 | 5417 | 5402 | 5388 | 5373 | 5358 | 5344 | 5329 | 5314 | 2 | 5 | 7 | 10 | 12 |
| 58 | 5299 | 5284 | 5270 | 5255 | 5240 | 5225 | 5210 | 5195 | 5180 | 5165 | 2 | 5 | 7 | 10 | 12 |
| 59 | 5150 | 5135 | 5120 | 5105 | 5090 | 5075 | 5060 | 5045 | 5030 | 5015 | 3 | 5 | 8 | 10 | 13 |
| 60 | 5000 | 4985 | 4970 | 4955 | 4939 | 4924 | 4909 | 4894 | 4879 | 4863 | 3 | 5 | 8 | 10 | 13 |
| 61 | 4848 | 4833 | 4818 | 4802 | 4787 | 4772 | 4756 | 4741 | 4726 | 4710 | 3 | 5 | 8 | 10 | 13 |
| 62 | 4695 | 4679 | 4664 | 4648 | 4633 | 4617 | 4602 | 4586 | 4571 | 4555 | 3 | 5 | 8 | 10 | 13 |
| 63 | 4540 | 4524 | 4509 | 4493 | 4478 | 4462 | 4446 | 4431 | 4415 | 4399 | 3 | 5 | 8 | 10 | 13 |
| 64 | 4384 | 4368 | 4352 | 4337 | 4321 | 4305 | 4289 | 4274 | 4258 | 4242 | 3 | 5 | 8 | 11 | 13 |
| 65 | 4226 | 4210 | 4195 | 4179 | 4163 | 4147 | 4131 | 4115 | 4099 | 4083 | 3 | 5 | 8 | 11 | 13 |
| 66 | 4067 | 4051 | 4035 | 4019 | 4003 | 3987 | 3971 | 3955 | 3939 | 3923 | 3 | 5 | 8 | 11 | 14 |
| 67 | 3907 | 3891 | 3875 | 3859 | 3843 | 3827 | 3811 | 3795 | 3778 | 3762 | 3 | 5 | 8 | 11 | 14 |
| 68 | 3746 | 3730 | 3714 | 3697 | 3681 | 3665 | 3649 | 3633 | 3616 | 3600 | 3 | 5 | 8 | 11 | 14 |
| 69 | 3584 | 3567 | 3551 | 3535 | 3518 | 3502 | 3486 | 3469 | 3453 | 3437 | 3 | 5 | 8 | 11 | 14 |
| 70 | 3420 | 3404 | 3387 | 3371 | 3355 | 3338 | 3322 | 3305 | 3289 | 3272 | 3 | 5 | 8 | 11 | 14 |
| 71 | 3256 | 3239 | 3223 | 3206 | 3190 | 3173 | 3156 | 3140 | 3123 | 3107 | 3 | 6 | 8 | 11 | 14 |
| 72 | 3090 | 3074 | 3057 | 3040 | 3024 | 3007 | 2990 | 2974 | 2957 | 2940 | 3 | 6 | 8 | 11 | 14 |
| 73 | 2924 | 2907 | 2890 | 2874 | 2857 | 2840 | 2823 | 2807 | 2790 | 2773 | 3 | 6 | 8 | 11 | 14 |
| 74 | 2756 | 2740 | 2723 | 2706 | 2689 | 2672 | 2656 | 2639 | 2622 | 2605 | 3 | 6 | 8 | 11 | 14 |
| 75 | 2588 | 2571 | 2554 | 2538 | 2521 | 2504 | 2487 | 2470 | 2453 | 2436 | 3 | 6 | 8 | 11 | 14 |
| 76 | 2419 | 2402 | 2385 | 2368 | 2351 | 2334 | 2317 | 2300 | 2284 | 2267 | 3 | 6 | 8 | 11 | 14 |
| 77 | 2250 | 2233 | 2215 | 2198 | 2181 | 2164 | 2147 | 2130 | 2113 | 2096 | 3 | 6 | 9 | 11 | 14 |
| 78 | 2079 | 2062 | 2045 | 2028 | 2011 | 1994 | 1977 | 1959 | 1942 | 1925 | 3 | 6 | 9 | 11 | 14 |
| 79 | 1908 | 1891 | 1874 | 1857 | 1840 | 1822 | 1805 | 1788 | 1771 | 1754 | 3 | 6 | 9 | 12 | 14 |
| 80 | 1736 | 1719 | 1702 | 1685 | 1668 | 1650 | 1633 | 1616 | 1599 | 1582 | 3 | 6 | 9 | 12 | 14 |
| 81 | 1564 | 1547 | 1530 | 1513 | 1495 | 1478 | 1461 | 1444 | 1426 | 1409 | 3 | 6 | 9 | 12 | 14 |
| 82 | 1392 | 1374 | 1357 | 1340 | 1323 | 1305 | 1288 | 1271 | 1253 | 1236 | 3 | 6 | 9 | 12 | 14 |
| 83 | 1219 | 1201 | 1184 | 1167 | 1149 | 1132 | 1115 | 1097 | 1080 | 1063 | 3 | 6 | 9 | 12 | 14 |
| 84 | 1045 | 1028 | 1011 | 0993 | 0976 | 0958 | 0941 | 0924 | 0906 | 0889 | 3 | 6 | 9 | 12 | 14 |
| 85 | 0872 | 0854 | 0837 | 0819 | 0802 | 0785 | 0767 | 0750 | 0732 | 0715 | 3 | 6 | 9 | 12 | 15 |
| 86 | 0698 | 0680 | 0663 | 0645 | 0628 | 0610 | 0593 | 0576 | 0558 | 0541 | 3 | 6 | 9 | 12 | 15 |
| 87 | 0523 | 0506 | 0488 | 0471 | 0454 | 0436 | 0419 | 0401 | 0384 | 0366 | 3 | 6 | 9 | 12 | 15 |
| 88 | 0349 | 0332 | 0314 | 0297 | 0279 | 0262 | 0244 | 0227 | 0209 | 0192 | 3 | 6 | 9 | 12 | 15 |
| 89 | 0175 | 0157 | 0140 | 0122 | 0105 | 0087 | 0070 | 0052 | 0035 | 0017 | 3 | 6 | 9 | 12 | 15 |

N.B.—Numbers in difference-columns to be subtracted, not added.

NATURAL TANGENTS.

| | 0' | 6' | 12' | 18' | 24' | 30' | 36' | 42' | 48' | 54' | 1 | 2 | 3 | 4 | 5 |
|----|------|------|------|------|------|------|------|------|------|------|---|----|----|----|----|
| 0° | 0000 | 0017 | 0035 | 0052 | 0070 | 0087 | 0105 | 0122 | 0140 | 0157 | 3 | 6 | 9 | 12 | 14 |
| 1 | 0175 | 0192 | 0209 | 0227 | 0244 | 0262 | 0279 | 0297 | 0314 | 0332 | 3 | 6 | 9 | 12 | 15 |
| 2 | 0349 | 0367 | 0384 | 0402 | 0419 | 0437 | 0454 | 0472 | 0489 | 0507 | 3 | 6 | 9 | 12 | 15 |
| 3 | 0524 | 0542 | 0559 | 0577 | 0594 | 0612 | 0629 | 0647 | 0664 | 0682 | 3 | 6 | 9 | 12 | 15 |
| 4 | 0699 | 0717 | 0734 | 0752 | 0769 | 0787 | 0805 | 0822 | 0840 | 0857 | 3 | 6 | 9 | 12 | 15 |
| 5 | 0875 | 0892 | 0910 | 0928 | 0945 | 0963 | 0981 | 0998 | 1016 | 1033 | 3 | 6 | 9 | 12 | 15 |
| 6 | 1051 | 1069 | 1086 | 1104 | 1122 | 1139 | 1157 | 1175 | 1192 | 1210 | 3 | 6 | 9 | 12 | 15 |
| 7 | 1228 | 1246 | 1263 | 1281 | 1299 | 1317 | 1334 | 1352 | 1370 | 1388 | 3 | 6 | 9 | 12 | 15 |
| 8 | 1405 | 1423 | 1441 | 1459 | 1477 | 1495 | 1512 | 1530 | 1548 | 1566 | 3 | 6 | 9 | 12 | 15 |
| 9 | 1584 | 1602 | 1620 | 1638 | 1655 | 1673 | 1691 | 1709 | 1727 | 1745 | 3 | 6 | 9 | 12 | 15 |
| 10 | 1763 | 1781 | 1799 | 1817 | 1835 | 1853 | 1871 | 1890 | 1908 | 1926 | 3 | 6 | 9 | 12 | 15 |
| 11 | 1944 | 1962 | 1980 | 1998 | 2016 | 2035 | 2053 | 2071 | 2089 | 2107 | 3 | 6 | 9 | 12 | 15 |
| 12 | 2126 | 2144 | 2162 | 2180 | 2199 | 2217 | 2235 | 2254 | 2272 | 2290 | 3 | 6 | 9 | 12 | 15 |
| 13 | 2309 | 2327 | 2345 | 2364 | 2382 | 2401 | 2419 | 2438 | 2456 | 2475 | 3 | 6 | 9 | 12 | 15 |
| 14 | 2493 | 2512 | 2530 | 2549 | 2568 | 2586 | 2605 | 2623 | 2642 | 2661 | 3 | 6 | 9 | 12 | 16 |
| 15 | 2679 | 2698 | 2717 | 2736 | 2754 | 2773 | 2792 | 2811 | 2830 | 2849 | 3 | 6 | 9 | 13 | 16 |
| 16 | 2867 | 2886 | 2905 | 2924 | 2943 | 2962 | 2981 | 3000 | 3019 | 3038 | 3 | 6 | 9 | 13 | 16 |
| 17 | 3057 | 3076 | 3096 | 3115 | 3134 | 3153 | 3172 | 3191 | 3211 | 3230 | 3 | 6 | 10 | 13 | 16 |
| 18 | 3249 | 3269 | 3288 | 3307 | 3327 | 3346 | 3365 | 3385 | 3404 | 3424 | 3 | 6 | 10 | 13 | 16 |
| 19 | 3443 | 3463 | 3482 | 3502 | 3522 | 3541 | 3561 | 3581 | 3600 | 3620 | 3 | 6 | 10 | 13 | 17 |
| 20 | 3640 | 3659 | 3679 | 3699 | 3719 | 3739 | 3759 | 3779 | 3799 | 3819 | 3 | 7 | 10 | 13 | 17 |
| 21 | 3839 | 3859 | 3879 | 3899 | 3919 | 3939 | 3959 | 3979 | 4000 | 4020 | 3 | 7 | 10 | 13 | 17 |
| 22 | 4040 | 4061 | 4081 | 4101 | 4122 | 4142 | 4163 | 4183 | 4204 | 4224 | 3 | 7 | 10 | 14 | 17 |
| 23 | 4245 | 4265 | 4286 | 4307 | 4327 | 4348 | 4369 | 4390 | 4411 | 4431 | 3 | 7 | 10 | 14 | 17 |
| 24 | 4452 | 4473 | 4494 | 4515 | 4536 | 4557 | 4578 | 4599 | 4621 | 4642 | 4 | 7 | 10 | 14 | 18 |
| 25 | 4663 | 4684 | 4706 | 4727 | 4748 | 4770 | 4791 | 4813 | 4834 | 4856 | 4 | 7 | 11 | 14 | 18 |
| 26 | 4877 | 4899 | 4921 | 4942 | 4964 | 4986 | 5008 | 5029 | 5051 | 5073 | 4 | 7 | 11 | 15 | 18 |
| 27 | 5095 | 5117 | 5139 | 5161 | 5184 | 5206 | 5228 | 5250 | 5272 | 5295 | 4 | 7 | 11 | 15 | 18 |
| 28 | 5317 | 5340 | 5362 | 5384 | 5407 | 5430 | 5452 | 5475 | 5498 | 5520 | 4 | 8 | 11 | 15 | 19 |
| 29 | 5543 | 5566 | 5589 | 5612 | 5635 | 5658 | 5681 | 5704 | 5727 | 5750 | 4 | 8 | 12 | 15 | 19 |
| 30 | 5774 | 5797 | 5820 | 5844 | 5867 | 5890 | 5914 | 5938 | 5961 | 5985 | 4 | 8 | 12 | 16 | 20 |
| 31 | 6009 | 6032 | 6056 | 6080 | 6104 | 6128 | 6152 | 6176 | 6200 | 6224 | 4 | 8 | 12 | 16 | 20 |
| 32 | 6249 | 6273 | 6297 | 6322 | 6346 | 6371 | 6395 | 6420 | 6445 | 6469 | 4 | 8 | 12 | 16 | 20 |
| 33 | 6494 | 6519 | 6544 | 6569 | 6594 | 6619 | 6644 | 6669 | 6694 | 6720 | 4 | 8 | 13 | 17 | 21 |
| 34 | 6745 | 6771 | 6796 | 6822 | 6847 | 6873 | 6899 | 6924 | 6950 | 6976 | 4 | 9 | 13 | 17 | 21 |
| 35 | 7002 | 7028 | 7054 | 7080 | 7107 | 7133 | 7159 | 7186 | 7212 | 7239 | 4 | 9 | 13 | 18 | 22 |
| 36 | 7265 | 7292 | 7319 | 7346 | 7373 | 7400 | 7427 | 7454 | 7481 | 7508 | 5 | 9 | 14 | 18 | 23 |
| 37 | 7536 | 7563 | 7590 | 7618 | 7646 | 7673 | 7701 | 7729 | 7757 | 7785 | 5 | 9 | 14 | 18 | 23 |
| 38 | 7813 | 7841 | 7869 | 7898 | 7926 | 7954 | 7983 | 8012 | 8040 | 8069 | 5 | 10 | 14 | 19 | 24 |
| 39 | 8098 | 8127 | 8156 | 8185 | 8214 | 8243 | 8273 | 8302 | 8332 | 8361 | 5 | 10 | 15 | 20 | 24 |
| 40 | 8391 | 8421 | 8451 | 8481 | 8511 | 8541 | 8571 | 8601 | 8632 | 8662 | 5 | 10 | 15 | 20 | 25 |
| 41 | 8693 | 8724 | 8754 | 8785 | 8816 | 8847 | 8878 | 8910 | 8941 | 8972 | 5 | 10 | 16 | 21 | 26 |
| 42 | 9004 | 9036 | 9067 | 9099 | 9131 | 9163 | 9195 | 9228 | 9260 | 9293 | 5 | 11 | 16 | 21 | 27 |
| 43 | 9325 | 9358 | 9391 | 9424 | 9457 | 9490 | 9523 | 9556 | 9590 | 9623 | 5 | 11 | 17 | 22 | 28 |
| 44 | 9657 | 9691 | 9725 | 9759 | 9793 | 9827 | 9861 | 9896 | 9930 | 9965 | 6 | 11 | 17 | 23 | 29 |

NATURAL TANGENTS.

| | 0' | 6' | 12' | 18' | 24' | 30' | 36' | 42' | 48' | 54' | 1 | 2 | 3 | 4 | 5 |
|-----|--------|-------|-------|-------|-------|-------|-------|-------|-------|-------|----|-----|-----|-----|-----|
| 45° | 1'0000 | 0035 | 0070 | 0105 | 0141 | 0176 | 0212 | 0247 | 0283 | 0319 | 6 | 12 | 18 | 24 | 30 |
| 46 | 1'0355 | 0392 | 0428 | 0464 | 0501 | 0538 | 0575 | 0612 | 0649 | 0686 | 6 | 12 | 18 | 25 | 31 |
| 47 | 1'0724 | 0761 | 0799 | 0837 | 0875 | 0913 | 0951 | 0990 | 1028 | 1067 | 6 | 13 | 19 | 25 | 32 |
| 48 | 1'1106 | 1145 | 1184 | 1224 | 1263 | 1303 | 1343 | 1383 | 1423 | 1463 | 7 | 13 | 20 | 26 | 33 |
| 49 | 1'1504 | 1544 | 1585 | 1626 | 1667 | 1708 | 1750 | 1792 | 1833 | 1875 | 7 | 14 | 21 | 28 | 34 |
| 50 | 1'1918 | 1960 | 2002 | 2045 | 2088 | 2131 | 2174 | 2218 | 2261 | 2305 | 7 | 14 | 22 | 29 | 36 |
| 51 | 1'2349 | 2393 | 2437 | 2482 | 2527 | 2572 | 2617 | 2662 | 2708 | 2753 | 8 | 15 | 23 | 30 | 38 |
| 52 | 1'2799 | 2846 | 2892 | 2938 | 2985 | 3032 | 3079 | 3127 | 3175 | 3222 | 8 | 16 | 23 | 31 | 39 |
| 53 | 1'3270 | 3319 | 3367 | 3416 | 3465 | 3514 | 3564 | 3613 | 3663 | 3713 | 8 | 16 | 25 | 33 | 41 |
| 54 | 1'3764 | 3814 | 3865 | 3916 | 3968 | 4019 | 4071 | 4124 | 4176 | 4229 | 9 | 17 | 26 | 34 | 43 |
| 55 | 1'4281 | 4335 | 4388 | 4442 | 4496 | 4550 | 4605 | 4659 | 4715 | 4770 | 9 | 18 | 27 | 36 | 45 |
| 56 | 1'4826 | 4882 | 4938 | 4994 | 5051 | 5108 | 5166 | 5224 | 5282 | 5340 | 10 | 19 | 29 | 38 | 48 |
| 57 | 1'5399 | 5458 | 5517 | 5577 | 5637 | 5697 | 5757 | 5818 | 5880 | 5941 | 10 | 20 | 30 | 40 | 50 |
| 58 | 1'6003 | 6066 | 6128 | 6191 | 6255 | 6319 | 6383 | 6447 | 6512 | 6577 | 11 | 21 | 32 | 43 | 53 |
| 59 | 1'6643 | 6709 | 6775 | 6842 | 6909 | 6977 | 7045 | 7113 | 7182 | 7251 | 11 | 23 | 34 | 45 | 56 |
| 60 | 1'7321 | 7391 | 7461 | 7532 | 7603 | 7675 | 7747 | 7820 | 7893 | 7966 | 12 | 24 | 36 | 48 | 60 |
| 61 | 1'8040 | 8115 | 8190 | 8265 | 8341 | 8418 | 8495 | 8572 | 8650 | 8728 | 13 | 26 | 38 | 51 | 64 |
| 62 | 1'8807 | 8887 | 8967 | 9047 | 9128 | 9210 | 9292 | 9375 | 9458 | 9542 | 14 | 27 | 41 | 55 | 68 |
| 63 | 1'9626 | 9711 | 9797 | 9883 | 9970 | 0057 | 0145 | 0233 | 0323 | 0413 | 15 | 29 | 44 | 58 | 73 |
| 64 | 2'0503 | 0594 | 0686 | 0778 | 0872 | 0965 | 1060 | 1155 | 1251 | 1348 | 16 | 31 | 47 | 63 | 78 |
| 65 | 2'1445 | 1543 | 1642 | 1742 | 1842 | 1943 | 2045 | 2148 | 2251 | 2355 | 17 | 34 | 51 | 68 | 85 |
| 66 | 2'2460 | 2566 | 2673 | 2781 | 2889 | 2998 | 3109 | 3220 | 3332 | 3445 | 18 | 37 | 55 | 74 | 92 |
| 67 | 2'3559 | 3673 | 3789 | 3906 | 4023 | 4142 | 4262 | 4383 | 4504 | 4627 | 20 | 40 | 60 | 79 | 99 |
| 68 | 2'4751 | 4878 | 5002 | 5129 | 5257 | 5386 | 5517 | 5649 | 5782 | 5916 | 22 | 43 | 65 | 87 | 108 |
| 69 | 2'6051 | 6187 | 6325 | 6464 | 6605 | 6746 | 6889 | 7034 | 7179 | 7326 | 24 | 47 | 71 | 95 | 118 |
| 70 | 2'7475 | 7625 | 7776 | 7929 | 8083 | 8239 | 8397 | 8556 | 8716 | 8878 | 26 | 52 | 78 | 104 | 130 |
| 71 | 2'9042 | 9208 | 9375 | 9544 | 9714 | 9887 | 0061 | 0237 | 0415 | 0595 | 29 | 58 | 87 | 115 | 144 |
| 72 | 3'0777 | 0961 | 1146 | 1334 | 1524 | 1716 | 1910 | 2106 | 2305 | 2506 | 32 | 64 | 96 | 129 | 161 |
| 73 | 3'2709 | 2914 | 3122 | 3332 | 3544 | 3759 | 3977 | 4197 | 4420 | 4646 | 36 | 72 | 108 | 144 | 180 |
| 74 | 3'4874 | 5105 | 5339 | 5576 | 5816 | 6059 | 6305 | 6554 | 6806 | 7062 | 41 | 82 | 122 | 162 | 203 |
| 75 | 3'7321 | 7583 | 7848 | 8118 | 8391 | 8667 | 8947 | 9232 | 9520 | 9812 | 46 | 94 | 139 | 186 | 232 |
| 76 | 4'0108 | 0408 | 0713 | 1022 | 1335 | 1653 | 1976 | 2303 | 2635 | 2972 | 53 | 107 | 160 | 214 | 267 |
| 77 | 4'3315 | 3662 | 4015 | 4374 | 4737 | 5107 | 5483 | 5864 | 6252 | 6646 | 62 | 124 | 186 | 248 | 310 |
| 78 | 4'7046 | 7453 | 7867 | 8288 | 8716 | 9152 | 9594 | 0045 | 0504 | 0970 | 73 | 146 | 219 | 292 | 365 |
| 79 | 5'1446 | 1929 | 2422 | 2924 | 3435 | 3955 | 4486 | 5026 | 5578 | 6140 | 87 | 175 | 262 | 350 | 437 |
| 80 | 5'6713 | 7297 | 7894 | 8502 | 9124 | 9758 | 0405 | 1066 | 1742 | 2432 | | | | | |
| 81 | 6'3138 | 3859 | 4596 | 5350 | 6122 | 6912 | 7920 | 8548 | 9395 | 0264 | | | | | |
| 82 | 7'1154 | 2066 | 3002 | 3962 | 4947 | 5958 | 6996 | 8062 | 9158 | 0285 | | | | | |
| 83 | 8'1443 | 2636 | 3863 | 5126 | 6427 | 7769 | 9152 | 0579 | 2052 | 3572 | | | | | |
| 84 | 9'5144 | 9'677 | 9'845 | 10'02 | 10'20 | 10'39 | 10'58 | 10'78 | 10'99 | 11'20 | | | | | |
| 85 | 11'43 | 11'66 | 11'91 | 12'16 | 12'43 | 12'71 | 13'00 | 13'30 | 13'62 | 13'95 | | | | | |
| 86 | 14'30 | 14'67 | 15'06 | 15'46 | 15'89 | 16'35 | 16'83 | 17'34 | 17'89 | 18'46 | | | | | |
| 87 | 19'08 | 19'74 | 20'45 | 21'20 | 22'02 | 22'90 | 23'86 | 24'90 | 26'03 | 27'27 | | | | | |
| 88 | 28'64 | 30'14 | 31'82 | 33'69 | 35'80 | 38'19 | 40'92 | 44'07 | 47'74 | 52'08 | | | | | |
| 89 | 57'29 | 63'66 | 71'62 | 81'85 | 95'49 | 114'6 | 143'2 | 191'0 | 286'5 | 573'0 | | | | | |

Difference-columns
cease to be useful, owing
to the rapidity with
which the value of the
tangent changes.

NATURAL COTANGENTS.

| | 0' | 6' | 12' | 18' | 24' | 30' | 36' | 42' | 48' | 54' | Difference-columns not useful here, owing to the rapidity with which the value of the cotangent changes. | | | | | | | | | | | | | | |
|----|--------|-------|-------|-------|-------|-------|-------|-------|-------|-------|--|-----|-----|-----|-----|--|--|--|--|--|--|--|--|--|--|
| 0° | Inf. | 573'0 | 286'5 | 191'0 | 143'2 | 114'6 | 95'49 | 81'85 | 71'62 | 63'66 | | | | | | | | | | | | | | | |
| 1 | 57'29 | 52'08 | 47'74 | 44'07 | 40'92 | 38'19 | 35'80 | 33'69 | 31'82 | 30'14 | | | | | | | | | | | | | | | |
| 2 | 28'64 | 27'27 | 26'03 | 24'90 | 23'86 | 22'90 | 22'02 | 21'20 | 20'45 | 19'74 | | | | | | | | | | | | | | | |
| 3 | 19'08 | 18'46 | 17'89 | 17'34 | 16'83 | 16'35 | 15'89 | 15'46 | 15'06 | 14'67 | | | | | | | | | | | | | | | |
| 4 | 14'30 | 13'95 | 13'62 | 13'30 | 13'00 | 12'71 | 12'43 | 12'16 | 11'91 | 11'66 | | | | | | | | | | | | | | | |
| 5 | 11'43 | 11'20 | 10'99 | 10'78 | 10'58 | 10'39 | 10'20 | 10'02 | 9'845 | 9'677 | | | | | | | | | | | | | | | |
| 6 | 9'5144 | 3572 | 2052 | 0579 | 9152 | 7769 | 6427 | 5126 | 3863 | 2636 | | | | | | | | | | | | | | | |
| 7 | 8'1443 | 0285 | 9158 | 8062 | 6996 | 5958 | 4947 | 3962 | 3002 | 2066 | | | | | | | | | | | | | | | |
| 8 | 7'1154 | 0264 | 9395 | 8548 | 7920 | 6912 | 6122 | 5350 | 4596 | 3859 | | | | | | | | | | | | | | | |
| 9 | 6'3138 | 2432 | 1742 | 1066 | 0405 | 9758 | 9124 | 8502 | 7894 | 7297 | | | | | | | | | | | | | | | |
| 10 | 5'6713 | 6140 | 5578 | 5026 | 4486 | 3955 | 3435 | 2924 | 2422 | 1929 | 1 | 2 | 3 | 4 | 5 | | | | | | | | | | |
| 11 | 5'1446 | 0970 | 0504 | 0045 | 9594 | 9152 | 8716 | 8288 | 7867 | 7453 | 74 | 148 | 222 | 296 | 370 | | | | | | | | | | |
| 12 | 4'7046 | 6646 | 6252 | 5864 | 5483 | 5107 | 4737 | 4374 | 4015 | 3662 | 63 | 125 | 188 | 252 | 314 | | | | | | | | | | |
| 13 | 4'3315 | 2972 | 2635 | 2303 | 1976 | 1653 | 1335 | 1022 | 0713 | 0408 | 53 | 107 | 160 | 214 | 267 | | | | | | | | | | |
| 14 | 4'0108 | 9812 | 9520 | 9232 | 8947 | 8667 | 8391 | 8118 | 7848 | 7583 | 46 | 93 | 139 | 186 | 232 | | | | | | | | | | |
| 15 | 3'7321 | 7062 | 6806 | 6554 | 6305 | 6059 | 5816 | 5576 | 5339 | 5105 | 41 | 82 | 122 | 163 | 204 | | | | | | | | | | |
| 16 | 3'4874 | 4646 | 4420 | 4197 | 3977 | 3759 | 3544 | 3332 | 3122 | 2914 | 36 | 72 | 108 | 144 | 180 | | | | | | | | | | |
| 17 | 3'2709 | 2506 | 2305 | 2106 | 1910 | 1716 | 1524 | 1334 | 1146 | 0961 | 32 | 64 | 96 | 129 | 161 | | | | | | | | | | |
| 18 | 3'0777 | 0595 | 0415 | 0237 | 0061 | 9887 | 9714 | 9544 | 9375 | 9208 | 29 | 58 | 87 | 115 | 144 | | | | | | | | | | |
| 19 | 2'9042 | 8878 | 8716 | 8556 | 8397 | 8239 | 8083 | 7929 | 7776 | 7625 | 26 | 52 | 78 | 104 | 130 | | | | | | | | | | |
| 20 | 2'7475 | 7326 | 7179 | 7034 | 6889 | 6746 | 6605 | 6464 | 6325 | 6187 | 24 | 47 | 71 | 95 | 118 | | | | | | | | | | |
| 21 | 2'6051 | 5916 | 5782 | 5649 | 5517 | 5386 | 5257 | 5129 | 5002 | 4876 | 22 | 43 | 65 | 87 | 108 | | | | | | | | | | |
| 22 | 2'4751 | 4627 | 4504 | 4383 | 4262 | 4142 | 4023 | 3906 | 3789 | 3673 | 20 | 40 | 60 | 79 | 99 | | | | | | | | | | |
| 23 | 2'3559 | 3445 | 3332 | 3220 | 3109 | 2998 | 2889 | 2781 | 2673 | 2566 | 18 | 37 | 55 | 74 | 92 | | | | | | | | | | |
| 24 | 2'2460 | 2355 | 2251 | 2148 | 2045 | 1943 | 1842 | 1742 | 1642 | 1543 | 17 | 34 | 51 | 68 | 85 | | | | | | | | | | |
| 25 | 2'1445 | 1348 | 1251 | 1155 | 1060 | 0965 | 0872 | 0778 | 0686 | 0594 | 16 | 31 | 47 | 63 | 78 | | | | | | | | | | |
| 26 | 2'0503 | 0413 | 0323 | 0233 | 0145 | 0057 | 9970 | 9883 | 9797 | 9711 | 15 | 29 | 44 | 58 | 73 | | | | | | | | | | |
| 27 | 1'9626 | 9542 | 9458 | 9375 | 9292 | 9210 | 9128 | 9047 | 8967 | 8887 | 14 | 27 | 41 | 55 | 68 | | | | | | | | | | |
| 28 | 1'8807 | 8728 | 8650 | 8572 | 8495 | 8418 | 8341 | 8265 | 8190 | 8115 | 13 | 26 | 38 | 51 | 64 | | | | | | | | | | |
| 29 | 1'8040 | 7966 | 7893 | 7820 | 7747 | 7675 | 7603 | 7532 | 7461 | 7391 | 12 | 24 | 36 | 48 | 60 | | | | | | | | | | |
| 30 | 1'7321 | 7251 | 7182 | 7113 | 7045 | 6977 | 6909 | 6842 | 6775 | 6709 | 11 | 23 | 34 | 45 | 56 | | | | | | | | | | |
| 31 | 1'6643 | 6577 | 6512 | 6447 | 6383 | 6319 | 6255 | 6191 | 6128 | 6066 | 11 | 21 | 32 | 43 | 53 | | | | | | | | | | |
| 32 | 1'6003 | 5941 | 5880 | 5818 | 5757 | 5697 | 5637 | 5577 | 5517 | 5458 | 10 | 20 | 30 | 40 | 50 | | | | | | | | | | |
| 33 | 1'5399 | 5340 | 5282 | 5224 | 5166 | 5108 | 5051 | 4994 | 4938 | 4882 | 10 | 19 | 29 | 38 | 48 | | | | | | | | | | |
| 34 | 1'4826 | 4770 | 4715 | 4659 | 4605 | 4550 | 4496 | 4442 | 4388 | 4335 | 9 | 18 | 27 | 36 | 45 | | | | | | | | | | |
| 35 | 1'4281 | 4229 | 4176 | 4124 | 4071 | 4019 | 3968 | 3916 | 3865 | 3814 | 9 | 17 | 26 | 34 | 43 | | | | | | | | | | |
| 36 | 1'3764 | 3713 | 3663 | 3613 | 3564 | 3514 | 3465 | 3416 | 3367 | 3319 | 8 | 16 | 25 | 33 | 41 | | | | | | | | | | |
| 37 | 1'3270 | 3222 | 3175 | 3127 | 3079 | 3032 | 2985 | 2938 | 2892 | 2846 | 8 | 16 | 23 | 31 | 39 | | | | | | | | | | |
| 38 | 1'2799 | 2753 | 2708 | 2662 | 2617 | 2572 | 2527 | 2482 | 2437 | 2393 | 8 | 15 | 23 | 30 | 38 | | | | | | | | | | |
| 39 | 1'2349 | 2305 | 2261 | 2218 | 2174 | 2131 | 2088 | 2045 | 2002 | 1960 | 7 | 14 | 22 | 29 | 36 | | | | | | | | | | |
| 40 | 1'1918 | 1875 | 1833 | 1792 | 1750 | 1708 | 1667 | 1626 | 1585 | 1544 | 7 | 14 | 21 | 28 | 34 | | | | | | | | | | |
| 41 | 1'1504 | 1463 | 1423 | 1383 | 1343 | 1303 | 1263 | 1224 | 1184 | 1145 | 7 | 13 | 20 | 26 | 33 | | | | | | | | | | |
| 42 | 1'1106 | 1067 | 1028 | 0990 | 0951 | 0913 | 0875 | 0837 | 0799 | 0761 | 6 | 13 | 19 | 25 | 32 | | | | | | | | | | |
| 43 | 1'0724 | 0686 | 0649 | 0612 | 0575 | 0538 | 0501 | 0464 | 0428 | 0392 | 6 | 12 | 18 | 25 | 31 | | | | | | | | | | |
| 44 | 1'0355 | 0319 | 0283 | 0247 | 0212 | 0176 | 0141 | 0105 | 0070 | 0035 | 6 | 12 | 18 | 24 | 30 | | | | | | | | | | |

N.B. — Numbers in difference-columns to be subtracted, not added.

NATURAL COTANGENTS.

| | 0' | 6' | 12 | 18' | 24' | 30' | 36' | 42' | 48' | 54' | 1 | 2 | 3 | 4 | 5 |
|-----|------|--------|--------|--------|--------|--------|--------|--------|--------|--------|---|----|----|----|----|
| 45° | 10 | 0'9965 | 0'9930 | 0'9896 | 0'9861 | 0'9827 | 0'9793 | 0'9759 | 0'9725 | 0'9691 | 6 | 11 | 17 | 20 | 29 |
| 46 | 9657 | 9623 | 9590 | 9556 | 9523 | 9490 | 9457 | 9424 | 9391 | 9358 | 6 | 11 | 17 | 22 | 28 |
| 47 | 9325 | 9293 | 9260 | 9228 | 9195 | 9163 | 9131 | 9099 | 9067 | 9036 | 5 | 11 | 16 | 21 | 27 |
| 48 | 9004 | 8972 | 8941 | 8910 | 8878 | 8847 | 8816 | 8785 | 8754 | 8724 | 5 | 10 | 16 | 21 | 26 |
| 49 | 8693 | 8662 | 8632 | 8601 | 8571 | 8541 | 8511 | 8481 | 8451 | 8421 | 5 | 10 | 15 | 20 | 25 |
| 50 | 8391 | 8361 | 8332 | 8302 | 8273 | 8243 | 8214 | 8185 | 8156 | 8127 | 5 | 10 | 15 | 20 | 24 |
| 51 | 8098 | 8069 | 8040 | 8012 | 7983 | 7954 | 7926 | 7898 | 7869 | 7841 | 5 | 10 | 14 | 19 | 24 |
| 52 | 7813 | 7785 | 7757 | 7729 | 7701 | 7673 | 7646 | 7618 | 7590 | 7563 | 5 | 9 | 14 | 18 | 23 |
| 53 | 7536 | 7508 | 7481 | 7454 | 7427 | 7400 | 7373 | 7346 | 7319 | 7292 | 5 | 9 | 14 | 18 | 23 |
| 54 | 7265 | 7239 | 7212 | 7186 | 7159 | 7133 | 7107 | 7080 | 7054 | 7028 | 4 | 9 | 13 | 18 | 22 |
| 55 | 7002 | 6976 | 6950 | 6924 | 6899 | 6873 | 6847 | 6822 | 6796 | 6771 | 4 | 9 | 13 | 17 | 21 |
| 56 | 6745 | 6720 | 6694 | 6669 | 6644 | 6619 | 6594 | 6569 | 6544 | 6519 | 4 | 8 | 13 | 17 | 21 |
| 57 | 6494 | 6469 | 6445 | 6420 | 6395 | 6371 | 6346 | 6322 | 6297 | 6273 | 4 | 8 | 12 | 16 | 20 |
| 58 | 6249 | 6224 | 6200 | 6176 | 6152 | 6128 | 6104 | 6080 | 6056 | 6032 | 4 | 8 | 12 | 16 | 20 |
| 59 | 6009 | 5985 | 5961 | 5938 | 5914 | 5890 | 5867 | 5844 | 5820 | 5797 | 4 | 8 | 12 | 16 | 20 |
| 60 | 5774 | 5750 | 5727 | 5704 | 5681 | 5658 | 5635 | 5612 | 5589 | 5566 | 4 | 8 | 12 | 15 | 19 |
| 61 | 5543 | 5520 | 5498 | 5475 | 5452 | 5430 | 5407 | 5384 | 5362 | 5340 | 4 | 8 | 11 | 15 | 19 |
| 62 | 5317 | 5295 | 5272 | 5250 | 5228 | 5206 | 5184 | 5161 | 5139 | 5117 | 4 | 7 | 11 | 15 | 18 |
| 63 | 5095 | 5073 | 5051 | 5029 | 5008 | 4986 | 4964 | 4942 | 4921 | 4899 | 4 | 7 | 11 | 15 | 18 |
| 64 | 4877 | 4856 | 4834 | 4813 | 4791 | 4770 | 4748 | 4727 | 4706 | 4684 | 4 | 7 | 11 | 14 | 18 |
| 65 | 4663 | 4642 | 4621 | 4599 | 4578 | 4557 | 4536 | 4515 | 4494 | 4473 | 4 | 7 | 10 | 14 | 18 |
| 66 | 4452 | 4431 | 4411 | 4390 | 4369 | 4348 | 4327 | 4307 | 4286 | 4265 | 3 | 7 | 10 | 14 | 17 |
| 67 | 4245 | 4224 | 4204 | 4183 | 4163 | 4142 | 4122 | 4101 | 4081 | 4061 | 3 | 7 | 10 | 14 | 17 |
| 68 | 4040 | 4020 | 4000 | 3979 | 3959 | 3939 | 3919 | 3899 | 3879 | 3859 | 3 | 7 | 10 | 14 | 17 |
| 69 | 3839 | 3819 | 3799 | 3779 | 3759 | 3739 | 3719 | 3699 | 3679 | 3659 | 3 | 7 | 10 | 13 | 17 |
| 70 | 3640 | 3620 | 3600 | 3581 | 3561 | 3541 | 3522 | 3502 | 3482 | 3463 | 3 | 6 | 10 | 13 | 17 |
| 71 | 3443 | 3424 | 3404 | 3385 | 3365 | 3346 | 3327 | 3307 | 3288 | 3269 | 3 | 6 | 10 | 13 | 16 |
| 72 | 3249 | 3230 | 3211 | 3191 | 3172 | 3153 | 3134 | 3115 | 3096 | 3076 | 3 | 6 | 10 | 13 | 16 |
| 73 | 3057 | 3038 | 3019 | 3000 | 2981 | 2962 | 2943 | 2924 | 2905 | 2886 | 3 | 6 | 9 | 13 | 16 |
| 74 | 2867 | 2849 | 2830 | 2811 | 2792 | 2773 | 2754 | 2736 | 2717 | 2698 | 3 | 6 | 9 | 13 | 16 |
| 75 | 2679 | 2661 | 2642 | 2623 | 2605 | 2586 | 2568 | 2549 | 2530 | 2512 | 3 | 6 | 9 | 12 | 16 |
| 76 | 2493 | 2475 | 2456 | 2438 | 2419 | 2401 | 2382 | 2364 | 2345 | 2327 | 3 | 6 | 9 | 12 | 15 |
| 77 | 2309 | 2290 | 2272 | 2254 | 2235 | 2217 | 2199 | 2180 | 2162 | 2144 | 3 | 6 | 9 | 12 | 15 |
| 78 | 2126 | 2107 | 2089 | 2071 | 2053 | 2035 | 2016 | 1998 | 1980 | 1962 | 3 | 6 | 9 | 12 | 15 |
| 79 | 1944 | 1926 | 1908 | 1890 | 1871 | 1853 | 1835 | 1817 | 1799 | 1781 | 3 | 6 | 9 | 12 | 15 |
| 80 | 1763 | 1745 | 1727 | 1709 | 1691 | 1673 | 1655 | 1638 | 1620 | 1602 | 3 | 6 | 9 | 12 | 15 |
| 81 | 1584 | 1566 | 1548 | 1530 | 1512 | 1495 | 1477 | 1459 | 1441 | 1423 | 3 | 6 | 9 | 12 | 15 |
| 82 | 1405 | 1388 | 1370 | 1352 | 1334 | 1317 | 1299 | 1281 | 1263 | 1246 | 3 | 6 | 9 | 12 | 15 |
| 83 | 1228 | 1210 | 1192 | 1175 | 1157 | 1139 | 1122 | 1104 | 1086 | 1069 | 3 | 6 | 9 | 12 | 15 |
| 84 | 1051 | 1033 | 1016 | 0998 | 0981 | 0963 | 0945 | 0928 | 0910 | 0892 | 3 | 6 | 9 | 12 | 15 |
| 85 | 0875 | 0857 | 0840 | 0822 | 0805 | 0787 | 0769 | 0752 | 0734 | 0717 | 3 | 6 | 9 | 12 | 15 |
| 86 | 0699 | 0682 | 0664 | 0647 | 0629 | 0612 | 0594 | 0577 | 0559 | 0542 | 3 | 6 | 9 | 12 | 15 |
| 87 | 0524 | 0507 | 0489 | 0472 | 0454 | 0437 | 0419 | 0402 | 0384 | 0367 | 3 | 6 | 9 | 12 | 15 |
| 88 | 0349 | 0332 | 0314 | 0297 | 0279 | 0262 | 0244 | 0227 | 0209 | 0192 | 3 | 6 | 9 | 12 | 15 |
| 89 | 0175 | 0157 | 0140 | 0122 | 0105 | 0087 | 0070 | 0052 | 0035 | 0017 | 3 | 6 | 9 | 12 | 14 |

N.B.—Numbers in difference-columns to be subtracted, not added.

INDEX

- Absorbing power for heat radiation, 148.
 Acceleration, angular, 78; linear, 78.
 Acceleration of gravity, by Atwood's machine, 73; by freely falling body, 75; by physical pendulum, 92; by Kater's pendulum, 96; value of, at Cornell Laboratory, 95.
 Air displacement, correction for, 117.
 Ammeter calibration, 267.
 Ampere, definition of, 236.
 Amplitude of S. H. M., 87.
 Approximations in computing, 7.
 Assignments of weights, 20.
 Atwood's machine, 70; gravity by, 73.
- Balance, 42.
 Ballistic galvanometer, 338; constant of d'Arsonval, 339; constant of tangent, 340.
 Barometer, cistern, 127; siphon, 127; comparison of, 127.
 Battery resistance, measurement of, by Beetz's method, 290; Benton's method, 330; fall of potential method for constant E. M. F. cells, 328; for open circuit cells, 329; Mance's method, 324; Mance's method as modified by Lodge and by Guthe, 326; Ohm's method, 321; Thomson's method, 323.
 Beetz's method for measuring E. M. F. and resistance of a battery, 290.
 Benton's method of measuring battery resistance, 330.
 "Bound" electricity, 203.
 Boyle's law, example of, 12; verification of, 124.
 Bunsen photometer, 183.
- Calibration, of an ammeter, 267; of a slide wire, 310; of a thermometer tube, 32; of a voltmeter, 296; of weights, 52.
 Calorimetry, general statements regarding, 133.
 Candle power, distribution of, by Bunsen and Lummer-Brodhun photometers, 188; standards, 186; variation of, with voltage, 190.
 Capacity, 346; measurement of, in absolute terms, 351; by comparison, ballistic method, 346; bridge method, 349.
- Cells, E. M. F. of, by Beetz's method, 290; by Ohm's method, 276; comparison of E. M. F.'s by Lord Rayleigh's method, 299; by Poggendorf's method, 298; by potentiometer method, 300; arrangement of, giving maximum current, 263; resistance (*see* Battery resistance); Standard Daniell, 261.
 Coefficients, cubical expansion, 155; friction, 63; frictional torque, 63; linear expansion, 154; mutual induction, 363; self-induction, 365.
 Coercivity, 375.
 Collimator, 168.
 Commutator or reversing switch, 239.
 Comparison, of barometers, 127; of thermometers, 134; of E. M. F.'s (*see* Cells, E. M. F. of).
 Computations, 5.
 Concave mirror, focal length of, 161; radius of curvature of, 162; center of curvature, 162.
 Condenser, capacity of, 346, 351; capacity in multiple, 348; in series, 348; principle of, 212; variable, 213.
 Conditions, choice of experimental, 4.
 Conductivity, 303.
 Conjugate foci, for convex mirror, 159; for concave mirror, 161; for convex lens, 163.
 Constant of galvanometer, ballistic, 340; for d'Arsonval, working, 244; d'Arsonval ballistic, 339; for tangent, true, 236; tangent, working, 237.
 Convex lens, focal length, 162; radius of curvature by reflection, 158; by spherometer, 29.
 Copper voltmeter, 250.
 Counter electromotive force, 270.
 Current electricity, general statements, 234; lines of flow, 292; measurement by electrolysis, 250; by magnetic effect, 245, 248; by Vienna method, 265; unit, 236.
 Curvature, radius of, by reflection, 158; by spherometer, 29; of concave mirror, 161.
 Curve plotting, 9, 24.
- Damping, of balance, 47; of vibrations, 91; of galvanometer needle, 341; theory of 342; ratio of, 343.

- Daniell cell, standard, 261.
 d'Arsonval galvanometer, constant of, 248; theory of, 242; used ballistically, 339.
 Decrement, logarithmic, 342.
 Demagnetizing effect of poles of a magnet, 376.
 Density, general statements, 115; from mass and dimensions, 35; definition, 115; with correction for temperature and air displacement, 117; by specific gravity bottle, 116; of liquids, by Hare's method, 122.
 Deviation, minimum, of light through a prism, 173.
 Difference of potential (*see* Potential).
 Differential pulley, 69.
 Diffraction, grating, 179; theory of, 179.
 Dip of earth's magnetic field, 356.
 Distance traversed with linear velocity, 72, 77.
 Distribution, of light, horizontal, 188; of free magnetism, 232, 259.
 Double weighing, 49.
 Earth inductor, 356.
 Efficiency, curve, 68; of pulley system, 68; of wheel and axle, 67.
 Elasticity, 101, 104, 107, 109.
 Electric, charge, bound, 203; free, 203; potential, 204, 205, 206; lines of force, 205.
 Electrical machine, 215, 217.
 Electrical quantity, general statements, 210, 337.
 Electrification, energy of, 202.
 Electrolysis, measurement of current by, 236, 250.
 Electrolytes, resistance of, 320.
 Electromagnetic induction, 352; mutual, 360; self, 356, 364.
 Electromagnetic, unit of current, 236; unit of E. M. F. and potential difference, 269.
 Electromotive force, general statements, 268; counter, 270; external, 274; impressed, 274; of a thermo-element, 294; total, 274; comparison of, by Lord Rayleigh's method, 299; by Poggendorf's method, 298; by potentiometer method, 300; measurement of, by Beetz's method, 290; by Ohm's method, 276; unit of, 269.
 Electroscope, 209.
 Electrostatic, lines of force, 205; potential, 206; induction, 210;
 Emisivity, 148.
 Equipotential, lines, 205; surfaces, 204, 205.
 Errors, accidental, 17; constant, 20; influence of, 21; probable, 18; sources of, 16.
 Estimation of tenths, 4.
 Expansion, coefficient of cubical, 155; linear, 154.
 Fahrenheit's hydrometer, 120.
 Fall of potential, method of resistance measurement, 311; in a circuit, 271, 275, 279; in wire carrying current, 287.
 Faraday's ice pail, 211.
 Field of force, electrical, 202; mapping, 205; unit, 207; magnetic, 219; computation of, due to current, 235; due to magnet, 227.
 Focal length, of concave lens, 165; of concave mirror, 161; of convex lens, 162.
 Forces, parallelogram of, 59; parallel, 61.
 "Free" charge, 203; electricity, 203; magnetism, 232.
 Friction, coefficient of moving, 9, 63; of frictional torque, 64.
 Fusion of ice, heat of, 144.
 Galvanometer, d'Arsonval, theory, 242; reduction factor, 244; tangent, theory, 245; reduction factor, 237; coil or true constant, 236 and 254; working constant, 237; to set in meridian, 238; to determine deflection with scale and mirror, 239; determination of constant of, 244, 248, 254, 259, 260, 261; damping, 241, 341, 342; ballistic, 338; potential, 280, 284; potential constant, 287; resistance (*see* Resistance).
 Gases, properties of, 124.
 Graphical representation of results, 9.
 Gratings, diffraction, 179.
 Gravity, by Atwood's machine, 73; by free fall, 75; by physical pendulum, 92; by Kater's pendulum, 96.
 Guthe, modification of Mance's method, 326.
 Hare's method of determining density, 122.
 Heat of fusion, of ice, 144; of vaporization of water, 142; specific heat by cooling, 146; by method of mixtures, 145; mechanical equivalent, 151.
 Hefner lamp, candle power and its variation, 186, 187.
 Henry, unit of induction, electromagnetic, 363.
 Holtz machine, 215, 217.
 Hydrometer, Fahrenheit's, 120; Nicholson's, 119.
 Impact, 109; elastic, 114; inelastic, 112.
 Impressed E. M. F., 274.
 Impulse, 109.
 Index of refraction, 173.
 Induced, currents, direction of, 353; E. M. F., 353.

- Induction, electrostatic, 203; electromagnetic, 352; mutual, 360; self, 364.
 Interference of sound waves, 192.
 Internal resistance of batteries (*see* Battery resistance).
 Interpretation of curves, 12.
 Joule's equivalent, 151.
 Kater's pendulum, 96.
 Kelvin, measurement of resistance of battery, 373; of galvanometer, 334; double bridge, 318.
 Kirchhoff's laws, 275.
 Koenig's apparatus, 192.
 Kundt's method for velocity of sound in solid rods, 195.
 Laplace's law, 235.
 Latent heat, of steam, 142; of water, 144.
 Least squares, method of, 24.
 Lens, curvature of, by reflection, 158; by spherometer, 29; focal length of concave, 165; of convex, 162.
 Leyden jar, 214.
 Light standards, Hefner lamp, 186; glow lamp, 187.
 Lines of equal potential in a conductor, 292.
 Lines of force, electrical, 203, 205, 208; determination of direction of, 208; magnetic, 219, 220; positive direction of, 220; study of, 222; around a wire carrying current, 235; of a permanent magnet, 358.
 Lodge, modification of Mance's method, 326.
 Logarithmic decrement, of galvanometer needle, 341; theory of, 342; determination of, 345.
 Magnet, axis of, 220; magnetic moment of, 221; earth a, 220; permanent, 220; poles, 220; force action between poles, 221.
 Magnetic field, study of, 222; measurement of intensity of, 230; lines of force, 219, 220; direction of, 220; of earth, study of, by inductor, 356.
 Magnetic hysteresis, 375.
 Magnetic induction, 373.
 Magnetic moment, 221; determination of, by oscillations, 224; by magnetometer, 226.
 Magnetic potential, 206.
 Magnetic properties of iron, general statement, 373; study of, by ballistic method, 383; by magnetometer method, 376.
 Magnetism, general statement, 219.
 Magnetization, lines of, 219, 373; intensity of, 373.
 Magnetometer, 226.
 Magnifying power of microscope, 167; or telescope, 166.
 Map, of an electrostatic field, 206; of a magnetic field of a magnet, 223; of a wire carrying a current, 235.
 Mance's method of measuring battery resistance, 324.
 Manometric capsule, 192.
 Mechanical equivalent of heat, 151.
 Melde's experiment, 199.
 Middle elongation, 38.
 Mirror, focal length of concave, 161.
 Modulus, slide, 106; Young's, 101.
 Moment of inertia, 82, 83; about parallel axis, 83; of a thin rod, 84; of a cylinder, 85; of a circular lamina, 85.
 Moment of torsion, 104.
 Moments, principle of, 61.
 Momentum, 109; moment of, 83, 339.
 Mutual induction, coefficient of, 360.
 Newton's law of cooling, 139, 150.
 Nicholson's hydrometer, 119.
 Observations, 3; record of, 2.
 Ohm, definition of, 304.
 Ohm's law, 270, 273; method of measuring E. M. F., 276; of measuring resistance of a battery, 321.
 Open-eye method of determining magnifying power, 167.
 Optical lever, 103.
 Parallel forces, 61.
 Parallelogram of forces, 59.
 Pendulum, Kater's, 96; physical, 92; simple, 96; uniform bar, 98.
 Periodic motion, 37; time of, by middle elongations, 37; by transits, 41; of uniform bar pendulum for varying position of knife-edges, 98.
 Permanent magnet, 220; measurement of lines of force of, 358.
 Permeability, 218, 374.
 Photometer, Bunsen, 183; Lummer-Brodhun, 184; Weber, 185.
 Photometry, 182; of gas burner, 188; of glow-lamp, 190.
 Physical equations of curves, 11.
 Physical pendulum, 92.
 Pitch of sound by syren, 192.
 Planimeter, 55.
 Polarization, effect upon current, 266.
 Potential, electrostatic, 207; magnetic, 207; fall in a series circuit, 279; in a wire, 287.
 Potential difference, 268; definition of, 268; electromagnetic unit of, 269; practical

- unit of, 269; variation at generator terminals, 284.
- Potential galvanometers, and measurers, 280, 285.
- Potential-resistance diagrams, 271, 272.
- Potentiometer, 300; Lord Rayleigh's method, 299; Poggendorf's method, 298.
- Principle of moments, 61.
- Prism, determination of angles of, 172; of angle of minimum deviation, 173; calibration of, 176.
- Probable error, 18.
- Proof plane, 209.
- Pulleys, system of, 68; differential, 69.
- Quantity of electricity, 337; produced by induction, 355; measurement of, by ballistic galvanometer, 337.
- Radiating and absorbing power of surfaces, 148.
- Radiation constant, 138.
- Radius of curvature, by reflection, 158; by spherometer, 29.
- Ratio, of balance arms, 52; of damping, 343.
- Refraction, index of, 173.
- Regulating magnet, 236, 262.
- Relative error, 23.
- Reports, 14.
- Residual charge, 214.
- Resistance, of battery (*see* Battery resistance); box, 304; coils, 304; general statements regarding, 303; methods of measurement, Carey Foster, 308; fall of potential, 311; Kelvin double bridge, 318; potentiometer, 300; Wheatstone bridge, 305; slide-wire bridge, 307; of electrolytes, 320; specific, 314; temperature coefficient, 315; unit, absolute, 303; practical, 304.
- Resonance of air columns, 194.
- Retentivity, 375.
- Reversing key, 239.
- Rheostat, 304.
- Rotational, energy, 82; inertia, 82.
- Self-induction, 364; coefficient of, 364; measurement of, by Anderson's method, 370; by comparison, 365; by Rimington's method, 367.
- Sensibility of a balance, 51.
- Sensitive galvanometer, 241; constant of, 258.
- Shunts, theory of, 255.
- Significant figures, 6.
- Simple harmonic motion, 86; amplitude of, 86; period of, 87; of rotation, 89; of translation, 87; examples of, 91.
- Slide rule, 5.
- Sonometer, 197.
- Sources of error, 16.
- Specific gravity, 115; by specific gravity bottle, 116; by Nicholson's hydrometer, 119 (*see* Density).
- Specific heat, method of cooling, 146; of mixtures, 145.
- Specific resistance, 314; measurement of, 314; of electrolytes, 320.
- Spectra, 175; of various substances, 177.
- Spectrometer, 168; adjustments, using Gauss' eyepiece, 169; using ordinary eyepiece, 171.
- Spectroscope, 168.
- Spherometer, 29.
- Standard cell, 290, 298, 301; Daniell, 261.
- Static, electricity, 202; induction, 210.
- Strings, law of vibrating, the sonometer, 197; Melde's method, 199.
- Susceptibility, 374.
- Syren, 192.
- Tables, 392-412.
- Tangent galvanometer, theory, 236; working constant, 237; constant per scale division, 240; as a quantity measurer, 340.
- Telescope, and scale, 239; magnifying power of, 166.
- Temperatures, errors in determining, 133; coefficient of expansion, cubical, 155; linear, 154; coefficient of resistance, 315.
- Tenths, estimation of, 4.
- Thermo-electromotive force, 294; variation with temperature, 295.
- Thermo-element, 294.
- Thermometers, calibration of, 32; comparison of, 134.
- Torque, 82.
- Torsion, moment of, 104.
- Total E. M. F., 274.
- Transverse vibrations, study of, 199.
- True constant of a galvanometer, 236, 254.
- Uniformly accelerated motion, circular, 78; linear, 71.
- Units, 7.
- Vapor, pressure of saturated, 130.
- Vaporization, heat of, 142.
- Variation of periodic time of a uniform cylindrical pendulum with variation of position of knife-edges, 98.
- Velocity attained with angular acceleration, 79; with linear acceleration, 72.
- Velocity of sound, in air, 194; in brass, 195.
- Vibrating strings, laws of, 197, 199.
- Vienna method of measuring current, 265.
- Volt, definition of, 269.

- Voltmeter, copper, 250; spiral coil, 250.
Voltmeter calibration, 296.
Volume determinations by measurement of dimensions, 35.
Water equivalent, of calorimeter, 136.
Wave-length, measurement of, of sound, 192; of light, 178.
Weighing, method of equal swings, 46; with a tare, 50; by vibrations, 47; precautions in, 45; reduction to vacuo, 50.
Weight, 7; in taking an average, 20.
Wheatstone bridge, 305.
Wheel and axle, 66.
Young's modulus, by flexure, 107; by stretching, 101; microscope method, 102; optical lever method, 103.

Heat for Advanced Students

By EDWIN EDSER, Associate Professor of the Royal College of Science, London ; Fellow of the Physical Society of London ; Author of "Light for Students," "Differential and Integral Calculus for Beginners," etc.

492 pages. \$1.00

My aim in writing this book has been to give a comprehensive account of the science of Heat in both its theoretical and experimental aspects, so far as this can be done, without the use of the higher mathematics. It is intended for students who already possess an elementary knowledge of fundamental physical principles, but whose training has not, as yet, qualified them to derive full benefit from more advanced text-books.

— From Author's Preface

Light for Students

By EDWIN EDSER, Associate of the Royal College of Science, London ; Fellow of the Physical Society of London ; Head of the Physics Department, Goldsmiths' Institute, New Cross ; Author of "Heat for Advanced Students," "Differential and Integral Calculus for Beginners," etc.

579 pages. \$1.50

Magnetism and Electricity for Students

By H. E. HADLEY, B.Sc. (Lond.), Associate of the Royal College of Science, London ; Headmaster of the School of Science, Kidderminster.

579 pages. \$1.00

Elementary Lessons in Electricity and Magnetism

By SILVANUS P. THOMPSON, D.Sc., B.A., F.R.S., F.R.A.S. ; Principal of and Professor of Physics in the City and Guilds of London Technical College, Finsbury ; Late Professor of Experimental Physics in University College, Bristol.

638 pages. \$1.40

Light Visible and Invisible

By SILVANUS P. THOMPSON

New edition. Cloth, 550 pages. \$2.00

PUBLISHED BY
THE MACMILLAN COMPANY
64-66 Fifth Avenue, New York

Applied Electrochemistry

By M. DE KAY THOMPSON, Ph.D., Assistant Professor of Electrochemistry in the Massachusetts Institute of Technology

Cloth, 8vo, 329 pages, index, \$2.10 net

This book was written to supply a need felt by the author in giving a course of lectures on Applied Electrochemistry in the Massachusetts Institute of Technology. There has been no work in English covering this whole field, and students had either to rely on notes or refer to the sources from which this book is compiled. Neither of these methods of study is satisfactory, for notes cannot be well taken in a subject where illustrations are as important as they are here; and in going to the original sources too much time is required to sift out the essential part. It is believed that, by collecting in a single volume the material that would be comprised in a course aiming to give an account of the most important electrochemical industries, as well as the principal applications of electrochemistry in the laboratory, it will be possible to teach the subject much more satisfactorily.

The plan adopted in this book has been to discuss each subject from the theoretical and from the technical point of view separately. In the theoretical part a knowledge of theoretical chemistry is assumed.

Full references to the original sources have been made, so that every statement can be easily verified. It is thought that this will make this volume useful also as a reference book.

An appendix has been added, containing the more important constants that are needed in electrochemical calculations.

PUBLISHED BY
THE MACMILLAN COMPANY

A History of Physics in its Elementary Branches

By FLORIAN CAJORI, Ph.D., Professor of Physics in Colorado College.

322 pages. \$1.60

This brief popular history gives in broad outline the development of the science of physics from antiquity to the present time. It contains also a more complete statement than is found elsewhere of the evolution of physical laboratories in Europe and America. The book, while of interest to the general reader, is primarily intended for students and teachers of physics. The conviction is growing that, by a judicious introduction of historical matter, a science can be made more attractive. Moreover, the general view of the development of the human intellect which the history of a science affords is in itself stimulating and liberalizing.

A Text-Book on Sound

By EDWIN H. BARTON, D.Sc. (Lond.), F.R.S.E., A.M.I.E.E., F.Ph.S.L., Professor of Experimental Physics, University College, Nottingham.

687 pages. \$3.00

"The admirable choice and distribution of experiments, the masterly character of the discussions, the ample scope of the work and its attractive typography and make-up, constitute it a welcome addition to the text-books of this division of physics." — D. W. HERING in *Science*.

Photography for Students of Physics and Chemistry

By LOUIS DERR, M.A., S.B., Associate Professor of Physics in the Massachusetts Institute of Technology.

243 pages. \$1.40

"The book is a most successful attempt to present a discussion of photographic processes, so far as their theory may be expressed in elementary form, in such a way that the ordinary photographic worker may secure a definite knowledge of the character and purpose of the various operations involved in the production of a photographic picture. . . . In other words, he has sought to fill that wide and somewhat empty middle ground between the good handbooks that are so common and the monograph which is often rather technical and always limited to some particular aspect of photography." — *Camera Craft*.

PUBLISHED BY
THE MACMILLAN COMPANY
64-66 Fifth Avenue, New York

Testing of Electro Magnetic Machinery and Other Apparatus

By BERNARD VICTOR SWENSON, E.E., M.E.,

of the University of Wisconsin, and

BUDD FRANKENFIELD, E.E.,

of the Nernst Lamp Company

Vol. I—Direct Currents

Cloth, 8vo, 420 pages, \$3.00 net

Vol. II—Alternating Currents

Cloth, 8vo, 324 pages, \$2.60 net

It is a book which can be thoroughly recommended to all students of electrical engineering who are interested in the design, manufacture, or use of dynamos and motors. . . . A distinct and valuable feature of the book is the list of references at the beginning of each test to the principal text-books and papers dealing with the subject of the test. The book is well illustrated, and there is a useful chapter at the end on commercial shop tests. — *Nature*.

The plan of arrangements of the experiments is methodical and concise, and it is followed in substantially the same form throughout the ninety-six exercises. The student is first told briefly the object of the experiment, the theory upon which it is based, and the method to be followed in obtaining the desired data. Diagrams of connections are given when necessary and usually a number of references to permanent and periodical literature suggest lines of profitable side reading and aid the experimenter in forming the desirable habit of consulting standard text outside the scope of the laboratory manual. Before performing the experiment the student also studies from the book the results previously obtained from standard apparatus by more experienced observers so that he may correctly estimate the value of his own measurements. In brief form are listed the data to be collected from the experiment and the reader is cautioned against improper use of the apparatus under test. A very valuable part of this feature of the instructions consists of remarks upon empirical design-constants, many of which the student may observe or measure for himself. Certain deductions, also, are called for with the evident purpose of showing the further practical application of the results obtained. — *Engineering News*.

PUBLISHED BY

THE MACMILLAN COMPANY

A Treatise on Hydraulics

By HECTOR J. HUGHES, A.B., S.B., M. Am. Soc. C.E.
Assistant Professor of Civil Engineering, Harvard University

AND

ARTHUR T. SAFFORD, A.M., M. Am. Soc. C.E.
Consulting Hydraulic Engineer
Lecturer on Hydraulic Engineering, Harvard University

Cloth, illustrated, 8vo, xiv+505 pp., index, diagrams, \$3.75

A text-book for technical colleges and schools on certain parts of the broad subject of Hydraulics; viz. water pressure, the flow of water, the measurement of flow, and the fundamental principles of hydraulic motors.

Elements of Electrical Transmission

By OLIN J. FERGUSON, M.E.E.
Associate Professor of Electrical Engineering in Union College

Cloth, illustrated, 8vo, 457 pp., index, \$3.50

In the preparation of this book the author has had constantly in mind its use as a text in college classes. He has therefore put into it the fundamentals which must be grasped before power development and distribution can be planned. Brief discussions are given of the elements and processes which go to determine the system.

PUBLISHED BY

THE MACMILLAN COMPANY

64-66 Fifth Avenue, New York

Properties of Matter

By P. G. TAIT, M.A., Sec. R.S.E., Honorary Fellow of St. Peter's College, Cambridge, Professor of Natural Philosophy in the University of Edinburgh. Fifth Edition by W. PEDDIE, D.Sc., F.R.S.E., Harris Professor of Physics in University College, Dundee, University of St. Andrews.

353 pages. \$2.25

The Principles and Methods of Geometrical Optics

Especially as Applied to the Theory of Optical Instruments

By JAMES P. C. SOUTHALL, Professor of Physics in the Alabama Polytechnic Institute.

626 pages. \$5.50

Professor Southall has written a complete and up-to-date treatise on the principles and methods of Geometrical Optics, especially as applied to the theory of optical instruments, such as the telescope, microscope, and photographic objective. The book is adapted for use as a college text-book. It will also prove invaluable as a book of reference for physicists, mathematicians, astronomers, opticians, oculists, and photographers, and, in a word, for any scientist who has occasion to study the theory of optical instruments.

Physical Optics

By ROBERT W. WOOD, LL.D., Professor of Experimental Physics in the Johns Hopkins University. Revised and Enlarged Edition.

New edition. Cloth, illustrated, 705 pages. \$5.25

"Every reader of Professor Wood's *Physical Optics* must be impressed with the value of the book as a compendium of the best modern views on optical phenomena. And it is a great satisfaction to find a book so full of the most valuable theoretical and experimental data which is written in a clear, forceful, and original style, always from the standpoint of the physicist rather than from that of the mathematician or the mere statistician."

—*Astrophysical Journal.*

PUBLISHED BY

THE MACMILLAN COMPANY

64-66 Fifth Avenue, New York

Electric Waves

By WILLIAM SUDDARDS FRANKLIN, Professor of Physics in Lehigh University. An Advanced Treatise on Alternating-Current History.

315 pages. \$3.00 net

"The author states that as it is most important for the operating engineer to be familiar with the physics of machines, the object of this treatise is to develop the physical or conceptual aspects of wave motion, that is, "how much waves wave," and that, with the exception of the theory of coupled circuits and resonance, it is believed that the "how much" aspect of the subject is also developed to an extent commensurate with obtainable data and the results derived from them. While this treatise is stated to be complete both mathematically and physically, as far as it goes, the student is referred to other works for the more elaborate mathematical developments."

— *Proceedings of the American Society of Civil Engineers.*

Modern Theory of Physical Phenomena, Radio-Activity, Ions, Electrons

By AUGUSTO RIGHI, Professor of Physics in the University of Bologna. Authorized Translation by AUGUSTUS TROWBRIDGE, Professor of Mathematical Physics in the University of Wisconsin.

165 pages. \$1.10 net

"The little book before us deals in a light and interesting manner with the conceptions of the physical world which have been used of late in investigating the phenomena of light, electricity, and radio-activity. It states the results of recent inquiries in a clear and intelligible manner, and, if the account of the methods used in reaching the results sometimes seems inadequate, the difficulty of explaining those methods to non-scientific readers may be urged as an excuse." — *Nature.*

Notes and Questions in Physics

By JOHN S. SHEARER, B.S., Ph.D., Assistant Professor of Physics, Cornell University.

281 pages. \$1.60 net

"The value of a book of this sort, for use in connection with a lecture course on physics, is beyond question; and the value of this particular book is enhanced by the circumstance that it is the outcome of an extended experience in the class-room."

— J. E. TREVOR in *The Journal of Physical Chemistry.*

PUBLISHED BY
THE MACMILLAN COMPANY
64-66 Fifth Avenue, New York

