

UNIVERSAL  
LIBRARY

**OU\_172475**

UNIVERSAL  
LIBRARY





OSMANIA UNIVERSITY LIBRARY

Call No. 681-42/D 48 D Accession No. 67636/...

Author Deve, ch.

Title Epical work shop Principle

This book should be returned on or before the date last marked below.



# OPTICAL WORKSHOP PRINCIPLES

being a translation of

“LE TRAVAIL DES VERRES D’OPTIQUE DE PRÉCISION”

*by*

COLONEL CHARLES DÉVÉ

(HONORARY DIRECTOR OF THE INSTITUTE OF THEORETICAL  
AND APPLIED OPTICS, PARIS)

*With a preface by*

CHARLES FABRY

DIRECTOR GENERAL OF THE INSTITUTE OF THEORETICAL AND APPLIED OPTICS  
MEMBER OF THE ACADEMIE DES SCIENCES

*Translated by*

THOMAS L. TIPPELL

ADAM HILGER LTD.

1943

*This translation is made from the revised edition published by  
"Revue d'Optique théorique et instrumentale", Paris, 1936*

A



PUBLICATION

**T**HE OPTICIAN'S ART CONSISTS IN  
CONSTRUCTING PERFECT SURFACES  
WITH TOOLS OF VERY IMPERFECT  
SHAPE

## TRANSLATOR'S FOREWORD

IN the preparation of this translation care has been taken to reflect the intentions of the original, but it is to be regretted that the march of current events has prevented that beneficial interchange of ideas between author and translator that would have otherwise been possible. It is hoped that the author will not find that the occasional dotting of "i's" and crossing of "t's" causes undesirable additions to or deviations from his text.

As is to be expected in any technique established by long custom, there are some technical terms which are not directly susceptible of translation, and in such cases an endeavour has been made to find an expression which fits the nature of the process or object. Readers are referred to the "vocabulary" for such usages.

I wish to give grateful acknowledgment to Mr. F. Twyman for his encouragement to me in undertaking and carrying out this pleasant task, and to my colleagues on the staff of Adam Hilger Ltd. who have given me occasional and invaluable assistance in elucidating some difficulties in technical details, especially to Mr. S. J. Underhill for his help with the vocabulary of terms.

T. L. T.



## PREFACE

THE technique which leads to the production of optical parts is delicate and highly specialised. It is distinguished from all others by the high precision required, which far surpasses that which is demanded of the most careful mechanical constructors, and it is peculiar also in the method of working, since the shape of a piece can be modified solely by methodically wearing down the surface. The tools thus employed are very simple, but that simplicity of means, which contrasts with the variety and complexity of metal working tools, is far from rendering the apprenticeship of the optician easier. An intelligent workman with a good general education soon learns how to use a new machine tool. He must have a long apprenticeship before he can make, in the right way, with the very simple tools of an optical workshop, a plane surface which is worthy to be called perfect.

These are the principles of the very curious technique set forth in Colonel Dévé's book. No one is better qualified than he to write it, following a long career in the course of which he created the optical artillery workshop at Puteaux, and then, in the quality of director of the Institut d'Optique, organised the trade school of that establishment where excellent working opticians have been trained. This long acquaintanceship with the optical workshop has led the author to reflect on the skill of the workers, the fruit of long practice, and to seek its bases, as well as the means of bringing it to perfection. The geometrical and mechanical theories of these processes of glass working are no easy matters. Geometers resolve the problems which they set themselves more willingly than those posed by the study of a technical process. Col. Dévé, good geometrician and good technician, has succeeded in constructing a coherent theory of "surfacing" and in deducing from it rules for workshop processes. In this book will be found, for the first time, a complete account of that theory and of its practical consequences. It is known, moreover, that the application of his theory has led M. Dévé to important technical improvements as well as to the solution of formerly unsolved problems, such as the production of perfect cylindrical surfaces whose need made itself felt in the construction of certain new apparatus.

But this more or less theoretical aspect of M. Dévé's book does not detract from its practical utility. They are bad workmen who fancy that there is conflict between "practice" and "theory". An experienced practical optician, the author of this book has introduced into it his profound workshop knowledge. The working optician, as

well as the apprentice, the foreman and the designer, will find there ample instructive matter, and all of them, if they encounter some difficulty in properly assimilating certain parts, will be well repaid for their pains by a more complete understanding of a difficult art; one of the most beautiful there is.

CH. FABRY.

## FOREWORD

TO THE FRENCH EDITION

IN order to profit from reading this book it is necessary to be already familiar with the tools and the usual operations in the working of optical glasses. One must also have the notions of optics and mechanics which are taught in the most elementary classes.

The appliances in current use are not described, for the descriptions and discussion of the various glass working machines would form the subjects of a special treatise.\*

This is not a manual for beginners. It is a résumé of the technical instruction which is given partly to the students at the School for the profession of optical glass working, during their three years' studies, and partly to the foremen and working opticians who come to improve themselves at the Institute of Theoretical and Applied Optics. It is also more a book for the master than for the pupil, for certain questions which are treated there need to be developed, and even prepared for, by more elementary lessons according to the degree of general education of the pupils.

The second part of the work is specially destined for optical engineers who have to direct precise optical workshops.

So far as concerns the working opticians and the apprentices, one might think that such scientific teaching is superfluous; actually it is certain that, at least in France, instruction of this sort has been dispensed with, and that nevertheless there exist workers, such as opticians, possessing a skill and competence which are not acquired from books. They know the numerous rule-of-thumb methods bequeathed by the former workers who have preceded them in the workshop; but do they know how much of these "methods" is just routine? Do they discover what is essential and what is unimportant in each workshop practice? And, if one asks them to make an object that they have not made for a long time, or even have never made before, how will they improvise a technique if they are ignorant of the reasons for their accustomed motions? A docile worker, little inclined to initiative, could continue to obtain good results without departing from the practices which he has learned. But the intelligent and less docile workman, who will succeed with a difficult object without practising his habitual "rule-of-thumb methods", believes himself cleverer than

\* Some account of such machinery will be found in Twyman, *Prism and Lens Making* (Hilger, London, 1942). (Trans.)

his masters and is always tending to innovations. How can he do this successfully if he does not know the fundamental laws of surfacing, the effects of the various movements which he combines, the reasons for the choice of abrasives and of polishers, and so on; if he is ignorant of what one may call the philosophy of his trade? Technology, in general, is the basis of all progress in manufacture.

The technology which forms the object of this guide is that of the worker in the optician's art working with the very simple lathes known as opticians' lathes, but I consider that the progress of optical manufacture will call more and more upon the mechanics' lathes, upon milling and grinding machines; the technology of the optician must then complete itself with the technology of the precision mechanic. The essential difference between the two technologies is that the practical unit in precision "mechanics" is the hundredth of a millimetre, whereas in precision optical work the practical unit is the interference fringe, which corresponds to a quarter of a micron. But, in optical work, mechanical precision suffices in many instances, such as in trueing, centring, edging and some smoothing. All these operations could, with advantage, be transported from the optical workshop to the mechanical workshop, when the worker has at his disposal copying lathes, turning lathes for spherical work or automatic lathes and grinding machines. The special tools exist already; mills for trueing, mills for smoothing, turning diamonds, etc. Unfortunately for the makers who only execute glass work, the obstacle to this progress is the necessity of buying expensive precision machines.

Nevertheless, the polishing of precision surfaces will always belong to the optician's technique, since it demands the employment of control processes allowing faults which measure only a tiny fraction of a micron to be clearly seen, and very special methods of working to obtain, with tools of very imperfect form, surfaces which are optically perfect. These processes and these methods constitute the essentials of the technology of the worker in the optical art.

I express my thanks to M. Ch. Fabry and to M. G. Guadet, head of the information service of the Optical Institute, for the invaluable assistance which they have afforded me by their enlightened criticism.

C. D.

## CONTENTS

	PAGE
TRANSLATOR'S FOREWORD - - - - -	iii
PREFACE - - - - -	v
FOREWORD (TO THE FRENCH EDITION) - - - - -	vii
VOCABULARY OF TECHNICAL TERMS - - - - -	xi

### PART I

#### ELEMENTARY

CHAP.

I. GLASSES—THEIR FAULTS—ABERRATIONS—CHOICE OF MATERIALS - - - - -	1
II. ABRASIVES—GLUES, RESINS AND CEMENTS—TOOLS—POLISHERS - - - - -	17
III. SURFACING - - - - -	50
IV. SPECTACLE LENSES - - - - -	100

### PART II

#### FOR THE USE OF WORKS MANAGERS AND SENIOR WORKMEN

V. THE MECHANICAL THEORY OF THE WORKING OF OPTICAL SURFACES - - - - -	114
VI. OPTICAL TESTS IN THE WORKSHOP - - - - -	174
VII. POLARISATION OF LIGHT. CRYSTAL SHAPING - - - - -	224
VIII. CENTRING, EDGING, AND CEMENTING LENSES - - - - -	252
IX. RETICULES (CROSS LINES), MICROMETERS AND GRATICULES - - - - -	272
X. METALLISATION OF MIRRORS - - - - -	284
NAME INDEX - - - - -	295
SUBJECT INDEX - - - - -	296



## VOCABULARY OF TECHNICAL TERMS EMPLOYED BY OPTICIANS

(Translator. The original French terms have been retained, and have been supplemented by the equivalent English terms when such exist).

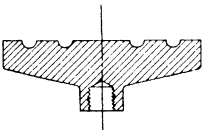
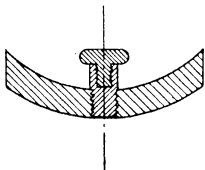
<i>French Term</i>	<i>English Equivalent</i>	<i>Explanation</i>
Balle	Convex tool	Spherical convex tool for surfacing (Fig. 16).
Bassin	Concave tool	Spherical concave tool for surfacing (Fig. 17).
Berzélius		Polishing paper, a kind of blotting paper.
Bloc	Block	Collection of objects cemented to a single support in order that they may be surfaced simultaneously (Figs. 16 and 17).
Bosse	'vex side	Curved surface of a plano-convex lens.
Brisoir	Bruiser	Convex or concave tool serving to crush and spread the abrasive paste on the corresponding working tool (concave or convex) before putting the tool on the glass, or vice versa.
Brucelles	Spring calipers	Little spring pincers (calipers).
Brutage or Ebrutage		Trueing with crushed diamond.
Caillebottage	"Scouring"	A process of grinding and a faulty procedure. The translator has arbitrarily called it "scouring" in the absence of any accepted English term.
Caillebotter (plateau à)	"Scouring plate"	Plate with circular grooves serving for trueing small convex lenses.
		
Calotte		Kind of spherical tool in cast iron, with detachable handle, serving for roughing either as a concave or convex tool according to the side to which the handle is attached.
		

Canon		Piece of crystal of long shape from which optical pieces are shaped.
Carotte	Stack	Cylinder formed of little discs stuck together in order to be edged.
Chair	Grey	Granular appearance of an insufficiently polished surface when examined with a magnifier.
Clivage	Cleavage	The operation of cutting a crystal parallel to one of its natural faces.
Coloir	Squeegee	Piece of glass whose extremity is rounded in a hemi-cylinder which serves to squeeze out the excess of adhesive under the paper, when preparing a paper polisher.
Cordon	"Leaving a witness"	Trueing "au cordon" means grinding the glass and leaving all round it a circular thread (border), "cordon", of an unground sample of the original surface, thus leaving a border of the surface as it was in a previous operation to verify that the edge thickness is still the same as before the present operation was performed.
Cotret	Mallet stick	Stick like a pencil. Very small lenses are stuck on mallet sticks. Also occasionally applied to driving pin of machine.
Couleurs (travail aux)	Working to test plate	Precision optical work is worked to the test plate, that is to say, according to examination of the coloured interference fringes which they exhibit when put in contact with a complementary glass test plate.
Couronne	Zone	Region of a lens surrounding the central region.
Courte (surface)	Deep	Surface whose curvature is too great ( <i>i.e.</i> whose radius is too short).
Cuirasse	Packing pieces	Laminae of cardboard or of tin which are stuck on to a curved tool in order to modify its curvature when making a polisher of it or to "block" some lenses.
Déborder	To edge	To shape the circumference of a lens.
Déglanter (maillet à)	Knocking-off mallet	A small mallet, a blow from which suffices to separate a lens from its "mallet".
Dégrossissage	Roughing	First grinding to shape.
Doucissage	Smoothing or fine smoothing	Final grinding to shape with fine emeries before polishing.

Dopp		Support upon which diamonds are held for working.
Ebauchage	Trueing	Second grinding to shape with coarse emery.
Echignures	Digs	A kind of claw mark on the surfaces of lenses.
Eclaircir	Clearing	Commencement of polishing.
Egrisé		Diamond powder. Sometimes a mixture of diamond powder and grease.
Equarrir (pince à)	Shanks	Or glaziers pliers. Serve to break small chips off the circumference of a lens blank in order to give it roughly the round or square form suitable for the object to be made.
Filandres	Sleeks	Marks left by the polishing tool, less deep than scratches.
Fils	Veins	Defects in glass which have the appearance of threads of syrup in water; the veins are said to be sharp or hazy (sec ou gras) according as their outlines are more or less sharp.
Fioner (pince à)	Flonk	Serves to break little chips on the surface of a squared-up glass to give it the approximate curvature that it must have before roughing.
Frayure	Slight scratch	Slight scratch.
Gaufrage	Pressing	Operation consisting of giving a spherical or toric form to a piece of polishing cloth or taffeta.
Gland	Mallet	Small block of pitch which serves to stick a lens on a working support.
Glanter	Malleting	Fixing mallets to lenses.
Gris	Grey	Appearance of an insufficiently polished surface.
Hirondelle		Template for shaping Nicol prisms.
Jeune (surface)	Shallow	Surface whose curvature is not yet sufficiently deep.
Macle	Twin crystal, twinning	When two crystals of the same mineral are joined to one another in an abnormal manner they form twin crystal, an intolerable fault in certain optical parts.
Minutage	Grading	Operation whose object is the selection of abrasives according to the number of minutes of their decantation.
Mollette	Mallet stick	Small lenses worked independently are mounted on "molettes", little wooden supports

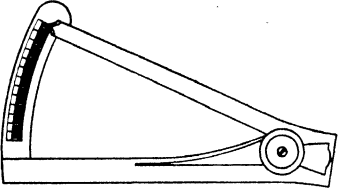
Mouche	Spot	Trueing "a la mouche" signifies that the lens is ground leaving in its centre a little sample (mouche) unground of the original surface, in order not to reduce the thickness of the lens.
Neige	Clouds	Mass of little matte floccules in a crystal.
Nicol	Nicol prism	Polarising and analysing prism.
Nonius	French gauge	Kind of vernier gauge for measuring the thicknesses of lenses. The name "nonius" is given to this kind of gauge even when deprived of a vernier. Originally one called "nonius" (from the inventor's name) a kind of oblique graduation which allowed a precise observation of fractions of a division. The nonius is generally replaced by the vernier (also from the name of the inventor). A gauge of the shape indicated is known as a French gauge.
		
Plateaux	Flat tools	Flat tools (Figs. 15 and 19).
Points crevés		Bubbles included in the lens and brought to light by surfacing.
Raffinage		Increase of fineness acquired by the abrasive in the course of working.
Rainer	Grooving	Edging a lens in such a way as to form around its edge a groove to receive a mounting.
Réunir	To true up flat or curved tools	To rub upon one another the two halves of a pair of tools.
Rose à polir		Cerium oxide.
Rouge à polir	Rouge	(Called English rouge or French rouge) is colcothar (red peroxide of iron) and is also a term applied to ferrous oxalate.*
Séchée	A wet	A period of smoothing or polishing with wet rouge, which stops at the instant when the abrasive mud becoming too dry, it is necessary to take off the lens or the tool to replace the mud or to dampen it.
Surfaçage	Surfacing	The whole series of operations of smoothing and polishing.
Tournette		Apparatus for circular cutting with the diamond.
Vacuole		Hollow inside a crystal.

\* Rouge is more usually understood to be ferrous oxide. (Trans.)

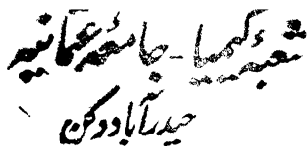

## PART I—ELEMENTARY

### CHAPTER I

#### GLASSES—THEIR FAULTS—ABERRATIONS—CHOICE OF MATERIALS

##### Indices of Refraction and Spectra

Before treating of the qualities of glasses it is well to recall some ideas of optics which are the bases of all examinations of a glass.

The index of refraction of a glass is a number which characterises the glass and allows the deviation which it will give to a ray entering at a given angle of incidence to be calculated.

For a single sample of glass there are as many indices as there are colours in the rainbow, that is to say, an infinity.

A pencil of light traversing a slit and a lens and then falling on a prism,\* forms beyond the prism a kind of rainbow which is called the *spectrum* of that light. On examining with a magnifier the spectrum formed by a hot flame containing (say) some iron, a great number of lines of progressively different colours are distinguished parallel to the slit and are images of it (one for each colour), lines which are peculiar to iron. They serve to scale and, as a result, to define the regions of the spectrum, that is to say, the colours in which they are situated. The most usual lines are the C line of hydrogen in the red, the D line of sodium in the yellow, and the F line of hydrogen in the blue.† White light is a mixture of all the colours of the rainbow. When one isolates one of these colours monochromatic light is obtained. The easiest to obtain is the yellow light (sodium D line) of a bunsen flame in which a little cooking salt (sodium chloride) has been placed.

Physicists have means of determining that the spectra extend much further than is visible. There are, beyond the violet end, invisible radiations which are called *ultra-violet*, and beyond the red end invisible radiations known as *infra-red*.

\* A piece of glass bounded by planes of which two play an optical role, the one serving as an entrance face for the light, the other as an exit face. These two faces are not parallel; they form between them an angle of, for example,  $30^\circ$ , which is called the angle of the prism.

† Most glass particulars in England are given for C, D, F and G', and there has been some attempt to substitute the principal mercury lines for the last three. (Trans.)

### Ordinary Glasses employed in Optical Work

It is not possible to make high quality lenses from just any piece of glass, since the interior faults of the glass would annul the perfection of the optician's work. Ordinary glasses are more or less coloured in the mass and absorb too much of the light when their thickness is rather great; they lack homogeneity, that is to say, they have not the same optical qualities throughout.

Nevertheless, the optical worker uses certain fairly commonly manufactured materials.

St. Gobain glass (plate glass), although it is of a greenish colour in thick pieces, is usable for making certain eyepiece lenses. The variations of refractive index from one melt to another are very slight; lenses made of St. Gobain glass in different years with the same curvatures have almost identical powers. The index for the D line varies but little, over a period of years, from a figure of 1.527. This glass has also an undisputed superiority over other materials for large astronomical mirrors. In this use, its greenish hue is not an inconvenience, and the refractive index does not matter, because the silvered reflecting surface must be an exterior surface. The St. Gobain Company is able to cast discs more than 2 m. in diameter and more than 20 cm. in thickness.

### Spectacle Glasses

The white glass for spectacle lenses is free from coloration, but it is only made in small thicknesses. It can be employed for certain ocular glasses as well as in the manufacture of spectacle lenses. For the latter use pieces containing bubbles must be carefully eliminated.

Among the most ancient of optical materials must be cited rock crystal, or quartz. It is a natural silica crystal used for a long time for spectacle lenses on account of its property of retaining mist less than does glass. It is particularly valuable nowadays for the construction of certain laboratory instruments because of its remarkable transparency for ultra-violet rays, a quality which is, moreover, a defect for its use in spectacle lenses, since such radiations fatigue the vision.

The working of quartz will be treated in the chapter relating to crystals employed in optics.

Recently the production of fused quartz plates of high transparency has been achieved; these plates are too little homogeneous to be transformed into prisms or lenses but this new material is valuable for making mirrors, curved test plates or proof planes, since it is very hard and is almost unaffected by variations of temperature, its coefficient of expansion being about fifteen times smaller than that of glass.

Numerous varieties of coloured glass are also employed in spectacle lenses. These are glasses derived from white glass by the addition of metallic oxides to the fused material.

There are neutral tinted glasses, blue glasses, yellow glasses, orange-yellow glasses called Fieuzal, glasses of a greeny-yellow tint called Euphos. All these glasses are numbered from 0 to 8, according to the intensity of their tint, those of the strongest colour having the highest numbers.\* Amethyst and green glasses are also used and are numbered from 0 to 3. When such coloured glasses are worked up into lenses, the colour of the glass is stronger in the thick portions and weaker in the thin ones. In order to avoid this inconvenience, glass makers provide for spectacle makers "isochromatic" glasses, formed from a lamina of white glass on which a piece of coloured glass of similar thickness has been fused. By grinding the coloured face very little and by taking away from the one white surface all that is necessary to obtain the power required, one can obtain very powerful lenses, that is to say, lenses of very unequal thickness, but of a constant hue from one edge to the other.

Instead of incorporating in the white glass oxides destined to tint it, that is to say, absorbent of certain radiations of the visible spectrum, one can incorporate certain bodies, for example, cerium oxide, which absorb the ultra-violet radiations very well and hardly absorb those of the visible spectrum at all. Thus are obtained white, or slightly tinted, glasses which protect the eyes from the most dangerous radiations. Such glasses are "Filtrays", "Phylex", "Crookes" and others.

### Optical Glasses

If only the primary optical materials indicated above existed, it would have been impossible to construct telescopes and other dioptric instruments (that is to say, instruments one sees through); one would be reduced to catoptric instruments (that is to say, to mirrors). The reason for this is that when light is made to traverse a piece of glass it is more or less deviated, split up and dispersed according to the nature of the material employed.

The substance glass is not a chemically defined body; it is a mixture of several silicates and other substances, each of which modifies the physical properties of the glass. Thus, an excess of boric acid renders the glass more liable to atmospheric damage and exaggerates its property of condensing the humidity of the atmosphere on its surface (hygroscopic glass). It is essential that all the materials which enter into the composition of a glass should be mixed very intimately

\* This is not a universal system of designating such glasses. Other makers have their own systems of nomenclature which are given in their catalogues. (Trans.)

in order that it should be comparable with itself in all its parts; that condition is difficult of realisation. Actually, when glass is heated, it becomes softer and softer as the temperature increases; it has no melting-point, and passes from the solid to the pasty state, and then to the syrupy state, while conserving a high viscosity which tends to oppose the intimate mixture of its constituent elements.

In order to appreciate the usefulness of a large variety of optical glasses, it must be understood that that variety is necessary to permit a good compensation for aberration to be obtained. It will, then, be convenient, before proceeding further, to summarise what are the aberrations to be corrected.

### The Aberrations

The study of the aberrations and of the calculation of optical combinations constitutes an important part of the science of the optical engineer. (The course in the calculation of optical combinations consists of 60 lessons at the *École supérieure d'Optique*.) It is impossible to embark upon this speciality without having an extensive knowledge of mathematics; nevertheless it is useful to know, by and large, what aberrations consist of.

Let a parallel beam of light fall upon a convergent lens, light coming from a star, for instance. The lens forms an image at its focus, but on observing that image with a magnifier, one perceives that it is not sharp and that it is fringed. If the image is received on a grey glass, in order to find the focus, and if a diaphragm is placed in front of the lens, a sharper image formed by the central rays is produced. But the grey glass is no longer at the focal point if, instead of cutting off the marginal rays, one intercepts the central rays. It is established that the focus of the marginal rays is not the same as that of the central rays. This difference is the effect of spherical aberration; the fringed effect is called chromatic aberration and results from the decomposition of the

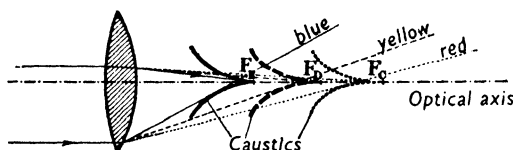

FIG. 1. Foci and caustics for red, yellow and blue radiations.

light by the lens. If a monochromatic light, such as that from a bunsen flame charged with salt, were used, there would be no chromatic aberration, but it would still be established that the central rays did not focus at the same point as the marginal rays. By using a red or a blue monochromatic light other foci would be found. ❀

Pushing the examination of the refracted beam further, it is established that all the rays of a monochromatic beam of parallel light are tangential to a sort of bell-mouthed horn like a loud speaker trumpet (Fig. 1); this kind of trumpet is the "caustic" for the light used. There are as many "caustics" as there are colours in the spectrum. If the biconvex lens studied is replaced by a lens of the same focal length but of another type, with unequal curvatures, plano-convex or meniscus, a different set of caustics is found in each case: there are some forms of lenses for which the caustics are closer together than for others.

The elementary study of prisms gives one a clear idea of what happens when one varies the form of a lens without changing its focal length.



FIG. 2. Prism in position of minimum deviation.

It is known that if a prism is placed in a parallel beam of light, that is to say, one coming from a long way away, the beam is more or less deviated according to the inclination of the prism; when the prism is equally inclined to the incident and refracted rays, the deviation is at a minimum (Fig. 2).

Let us take a lens of the meniscus type, that is to say, one whose section is that of the crescent moon; let us cut it across the middle and place the upper half with its convexity towards the incident light,

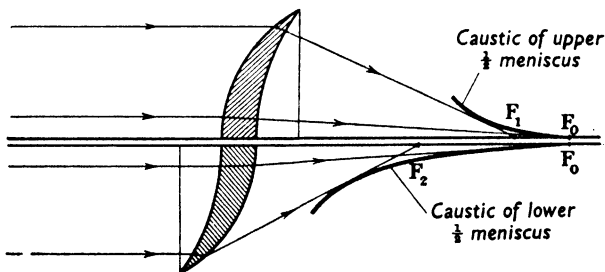

FIG. 3.  $F_0$ , Focus of central rays;  $F_0 F_1$ , Aberration of upper meniscus;  $F_0 F_2$ , Aberration of lower meniscus.

and the other half with its concavity towards the incident light (Fig. 3). Let us isolate a narrow marginal pencil; for this the lens acts as a prism element tangential to the entrance and exit faces. In the upper half of the lens the little prism is almost in the position of minimum deviation; in the lower half the prism is very far removed from its

position of minimum deviation; hence it gives a more refracted beam than that of the upper half and the pencil is bent more to the left; it results from this that the caustic of the lower half is more accentuated (longer) than that of the upper half.

There is, then, less spherical aberration when the greater convexity of a lens is presented to the parallel incident light.

Analogous phenomena are observed with divergent lenses but the caustics are reversed, that is to say that the aberrations are in a contrary sense. For convergent lenses the caustics direct their points to the side where the light goes; divergent lenses direct the points of their caustics to the side from which the light comes.

Thus one can hope to reduce spherical aberrations by combining a convergent lens with a divergent one.

If to a convergent lens having the shape yielding almost the minimum spherical aberration is affixed a divergent lens whose faces are strongly inclined to the incident rays, one can compensate the spherical

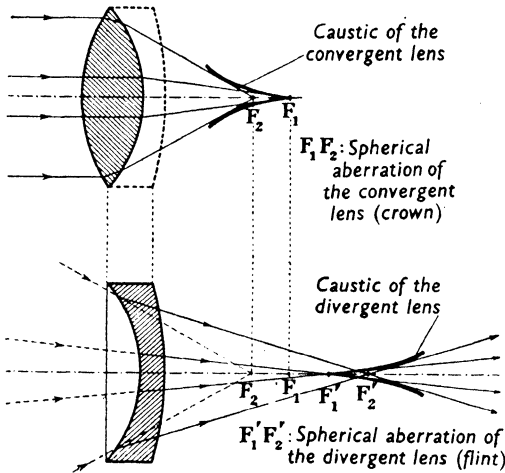

FIG. 4. Two-lens aplanatic objective.

aberration of the convergent lens by adding to it a weaker divergent lens; consequently the combination of the two lenses forms a convergent combination corrected for spherical aberration; the combination is said to be aplanatic (from the Greek *a*, deprived of, and *plane*, aberration \*). (Fig. 4.)

If the points  $F_1$  and  $F_2$  were merged, that is to say, if the convergent lens were aplanatic, the divergent lens would distribute their images

\* More correctly derived from "Greek *a* + *planaō*, wander; adj. from Greek *aplanetos*, free from error", *Concise O.E.D.* (Trans.)

from  $F_1'$  to  $F_2'$ . But the point  $F_2$  is further to the left than  $F_1$ ; its image  $F_2'$  formed by the divergent lens must, then, also be more to the left, that is to say, brought back towards  $F_1'$ ; it will even be exactly brought back there if the shapes of the two lenses are well calculated in relation to the refractive indices of the two glasses for the D lines.

It is possible to obtain exact correction in an infinity of ways. One could change the relative powers of the two lenses without changing their materials; one could also make them of different substances. Profiting by these facilities, the computer is at liberty to impose upon himself other conditions such as, for instance, to cement the lenses together by surfaces of equal curvature, the one convex, the other concave.

It is the dispersive power of the glasses which enters into the correction of chromatic aberration; the difference of the refractive indices of a glass for two radiations of different colours (red and violet, for example) is called its dispersion. Catalogues usually give the dispersion for the F and C lines of the spectrum, indicated by  $(n_F - n_C)$ . The dispersive power is the ratio of the dispersion to the refractive index for a certain radiation (most usually the D line) reduced by unity.

The dispersive power is thus written  $\frac{n_F - n_C}{n_D - 1}$ . Optical glass catalogues do not give the dispersive power but its reciprocal, which is designated by the Greek letter  $\nu$  (nu):

$$\nu = \frac{n_D - 1}{n_F - n_C}.$$

The dispersive power varies considerably with the composition of the glasses. Generally the dispersive power is greater for the more refringent glasses, but certain glasses form exceptions to this rule.\*

It is conceivable that if two lenses of different materials, a convergent lens and a divergent lens, are combined, and if the second has a very much greater dispersive power than that of the first, compensation of the dispersion is obtainable by giving to the divergent lens a power less than that of the convergent lens. The combination of the two lenses thus forms an achromatic, convergent combination; that is to say, one corrected from chromatic aberration. It is demonstrable that exact compensation is obtained when the focal lengths  $f_1$  and  $f_2$  of the two lenses are proportional, in absolute value, to their dispersive powers  $\frac{1}{\nu_1}$  and  $\frac{1}{\nu_2}$ ; the condition of achromatism is then written

$$\nu_1 f_1 = \nu_2 f_2.$$

\* See the new glasses made by Kodak, 1942 (*J. Sci. Inst.*, **12**, 94, June). (Trans.)

Thus chromatic aberration, like spherical aberration, is corrected by coupling a convergent lens with a divergent lens (Fig. 5).

If the convergent lens were achromatic, the flint would distribute the foci for the red, yellow and blue over  $F'_D, F'_D, F'_F$ . But the convergent lens has its blue focus  $F_F$  more to the left than the yellow and red foci; the conjugate  $F'_F$  of  $F_F$  in relation to the flint is then brought

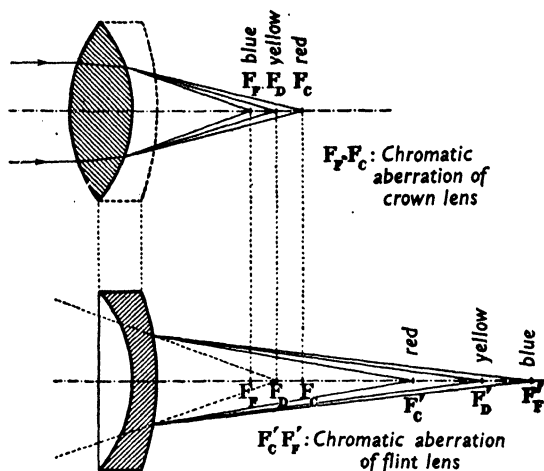

FIG. 5. Achromatic objective.

back towards  $F'_D$ . It would be brought there exactly if the dispersive powers of the two lenses were proportional to their focal lengths (Fig. 5).

If one has at one's disposal a sufficient range of glasses of different dispersive powers one can choose, almost arbitrarily, the refractive indices  $n_D$  and  $n'_D$  of a convergent lens and a divergent lens, calculate the curvatures and the focal lengths of the lenses with a view to compensating the spherical aberration and afterwards obtain chromatic correction by choosing among the glasses of refractive indices  $n_D$  and  $n'_D$  two materials which have dispersive powers satisfying the conditions enunciated above.

Axial aberrations are the easiest to correct. Aberrations away from the axis are more complex. When an oblique pencil falls on a lens, the refracted rays, instead of converging towards a point, fall upon two little rectangular elements of straight lines, distant from one another to an appreciable extent. (If these straight lines cut one another the pencil will converge to their intersection.) The images formed by such pencils are marred by astigmatism. (From the Greek  $\alpha$ , excluded from,

and *stigma*, point.) \* But for such images, as for those on the axis, the aberrations of convergent lenses are in a contrary sense to those of divergent lenses; one can, then, still compensate the one by the other. Without that compensation the images would no longer be sharp at any distance from the centre of the field. Objectives corrected from astigmatism are said to be anastigmats. There are some anastigmats which are not aplanatic on the axis.

There are still plenty of other conditions to satisfy, such as wide field; high luminosity, that is to say, large aperture of the objective; correction of the achromatism for the more actinic radiations, *i.e.* for the rays which, less visible than the green or yellow rays, are nevertheless more active with respect to photographic plates. In order to satisfy these numerous conditions, two lenses no longer suffice; one must have recourse to complicated combinations of three or four lenses of varying refringencies and of suitable dispersive powers. Accordingly as the glass makers have increased the range of their special glasses, the realization of new solutions for these numerous optical problems has become possible.

### Special Glasses

The first special glasses for optical work were obtained at the commencement of the last century by a French firm. In 1839, the "Société d'encouragement pour l'industrie nationale" awarded, for the first time, a prize to an optical glass works, the firm of Feil et Guinand, which has become the firm of Parra-Mantois et Cie, long known throughout the whole world.

Up to the middle of the nineteenth century, only a range of glasses was made of which the dispersive powers increased more or less with the mean refrangibility. The less refringent are called crown glass, the more refringent flint glass. These English denominations come from Chance's Glass Works, started in England in 1848 † by a former associate of Guinand's. The word crown comes from the shape of these glasses at a certain stage of their manufacture.‡ Nevertheless the firm of Feil and Mantois was the first to succeed in making glasses which were highly refringent and of small dispersion, but the utility of these costly products was not immediately understood, and the indus-

\* According to *Concise O.E.D.*, the derivation is from Greek *a*, not + *stigmamatos*, point + *ic*. (Trans.)

† Chance's Works at Smethwick were started in 1824; some experimental work on optical glass making was commenced in 1838 but little seems to have been done until Bontemps arrived in 1848 (see J. F. Chance, *History of the Firm of Chance Brothers and Co.* (Trans.)

‡ When the glassmaker had gathered on the end of his blowpipe a mass of glass for blowing he gave his pipe a rotary movement which imparted a vaguely crown-like shape to the mass.

trialisation of their manufacture was not accomplished at that period.

It is the merit of the Germans to have developed the manufacture of the new glasses, but they did not create their first optical glass works at Jena until 1884, that is to say, more than half a century after the French. France conserves the honour of priority and her production has never been inferior in quality to that of the foreigner. As soon as the new special glasses were appreciated by constructors the firm of Feil and Mantois resumed the manufacture which they had first commenced several years before and offered to constructors products entirely comparable to and quite as varied as those from Jena. An enormous publicity on the part of the Germans has spread among the public the false idea that the Jena glasses are incomparable, so that one is astonished to learn that a very important part of the French production of optical glasses was bought by the Germans before the Great War (1914–1918).

<b>Dense Barium Crown. No. 4006</b>		
Density: 3.068		
Lines	Wavelengths	Refractive Index
A'	7685	1.60769
C	6563	1.61155
D	5893	1.61487
F	4861	1.62295
G'	4341	1.62952
Mercury	4047	1.63452
Mean dispersion (C – F) 0.01140.		
$\nu = \frac{n_D - 1}{n_F - n_C} = 53.9$		
	Partial dispersion	Ratio of partial to mean dispersion
From A' to C	0.00386	0.339
,, C to D	0.00332	0.291
,, D to F	0.00808	0.709
,, F to G'	0.00657	0.576
,, G' to 4047	0.00500	0.439

Particulars of a Melting, from a Catalogue of optical glasses.

The preceding is necessary in order to understand a catalogue of optical glasses. As it is not possible to reproduce a chosen melting with absolute certainty and in an absolutely identical manner, each melting is numbered and its ticket gives the number of the melting, the nature of the glass, the indices of refraction for the different radiations designated by the spectrum lines produced by certain incandescent bodies, potassium and hydrogen for the red (lines A' and C), sodium for the yellow (line D), hydrogen for the green and blue (lines F and G'), mercury for the violet (line 4047A). From these figures one deduces the mean dispersion from red to green, the dispersive power and its reciprocal ( $\nu$ ).

The catalogues give yet other figures which are useful for computers and are deduced from the indices; these are the partial dispersions and the dispersion ratios. In addition, two columns indicate the densities and the prices; finally some information is given on the transparency of certain meltings. Different glasses absorb more or less of such and such radiations, thus the "uviol" glasses are particularly transparent to ultra-violet radiations, less so, however, than quartz.

The glasses are arranged more or less in the order of their refrangibilities, the borosilicate crowns (B.S.C.), the ordinary light crowns (hard crowns, H.C.), the barium crowns (L.B.C. or D.B.C.), the light or heavy flints (L.F. or D.F.), the light or dense baryta flints (B.L.F. or B.D.F.), and the boro-silicate flints (B.S.F.). In a general way the basis of crown glasses is lime and potash, like Bohemian glass; the basis of flint glass is potash and lead, like crystal.

At the end of the catalogues one often finds mention of uranium glasses. These are yellow glasses which enjoy the property of becoming fluorescent under the action of ultra-violet radiation. From them are made screens which make the images formed by ultra-violet radiation visible, just as a grey glass screen makes visible the images produced by visible radiations.

The indices are given to five decimals. Such a precision has no meaning unless the glasses are perfectly homogeneous, that is to say, if from one piece to another in the same melting the index does not vary by more than one or two units in the fifth place. The defect of inhomogeneity can arise from insufficient stirring of the melted substance or from contraction during cooling\*, even occasionally from a change of state during the ageing of the material.

Stirring is the most delicate operation in manufacture, for it only needs the stirring tool (which is called a *guinand* in France, from the name of its inventor) to introduce the least trace of foreign matter, as would be done, for instance, by a bar of iron, to spoil the melt, therefore it is made of a refractory earth. It is necessary, moreover, to continue stirring

\* See Twyman and Simeon (*T. Soc. Glass Tech.*, 7, 199). (Trans.)

until the thickening of the glass renders it impossible, otherwise, the elements of the diverse materials which compose a melting tend to separate from one another. The defects resulting from insufficient stirring are called veins; they have the appearance of syrupy threads, such as a few drops of "sirop" \* form in a glass of water before the mixture has been agitated with a spoon. This appearance is the result of small differences of refraction in certain regions. Veins constitute unacceptable defects; the parts of the glass which contain them must be carefully eliminated.

Bubbles result from the release of gases which have not had time to rise to the surface of the molten matter before it has solidified. Bubbles are inadmissible in spectacle lenses but are tolerable in objectives; there are, indeed, special glasses from which it is almost impossible to eliminate them completely. They are not, however, more deleterious than are particles of dust of the same size.

The contraction of the glass also alters its refraction; spontaneous contraction is produced by cooling. The exterior layers, solidifying first of all, resist the pull of the interior soft material which on cooling in its turn tends to diminish in volume. The state of the glass thus contracted is known as "temper" (or "strain"). It is a state analogous to that of steel which, having been made red hot, has been tempered in a bath of water or of oil. Glass tempers itself much more easily; contact with the air suffices. Drops of molten glass which are tempered in water form Rupert's Drops (*larmes bataviques*), which possess such a molecular tension that they explode if their surface is scratched. All ordinary glasses show traces of strain.

One sometimes also finds, in plates of glass, some cloudy regions which must, naturally, be discarded.

### The Examination of Glasses

A preliminary test is made in the glass works itself. One by one all the pieces of glass coming from the cooled crucible are examined, and only those are kept which have a good appearance. They are moulded, by re-softening, into the forms of discs or plates, which are left to cool very slowly for several days. The plates are delivered to the optician as of first or second quality.

The first quality plates, polished on two opposite edges, have been examined by the glass maker; the second quality plates have no polished edges and are sold without guarantee.

In order not to risk expending workmanship on a glass which might be rejected for faulty material, the optician must, before putting any work in hand, proceed to a fresh and more meticulous examination of

\* Concentrated sweetened and flavoured liquids diluted to form a rather sickly beverage popular in France. (Trans.)

the glass than that carried out by the glass maker, even upon the first quality glasses.

Bubbles and clouds are easily seen. The search for veins is more delicate. Most often for this examination one uses the edge of a roof or a chimney which is sharply defined against the sky. Seen through the plate, the edge observed should not suffer any deformation, and at no point should the luminous part encroach upon the shade, or vice versa.

Another method, more delicate to apply, is also more sensitive. By means of a very simple optical system a real image of a brilliant and very small light source is formed. The eye, placed exactly at the point where this image is formed, sees the field of the system uniformly illuminated. All the faults which the glasses traversed can present then appear clearly. The introduction of a perfectly good plate of glass in the path of light should not alter it in the least, even if the plate is displaced in order to examine every part of it.\*

But these procedures often leave unperceived, even by experienced opticians, veins which are still harmful in the production of objectives. The method of projected shadows (*ombres portées*), recently perfected by M. Albert Arnulf, head of practical work at the Institut d'Optique, is incomparably more sensitive and is easily carried out, but one must work in a darkened room.

A very bright, very small light source is still necessary; it is perfectly realised in the Pointolite lamp.† Some metres from the source (Fig. 6), the plate of glass, or the optical component which one wishes to examine, is placed in such a manner as to present one of its polished faces to the incident light. Behind the piece to be examined is placed

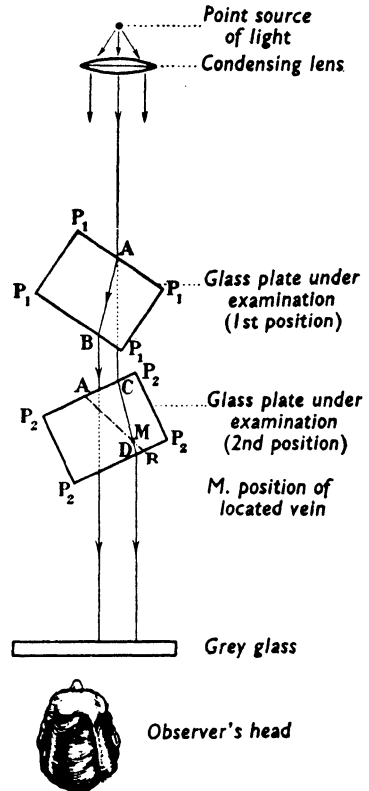

FIG. 6. Location of faults in a plate of glass.

\* This is similar to a process known at Hilger's as "flaring"; the eye and the glass are put at conjugate foci of the lens. (Trans.)

† Made by the Edison Swan Electrical Co., Ponders End, London. (Trans.)

a grey glass to receive the projected shadow of this piece. In the midst of the projected shadow, clearly standing out black, appear the projected shadows of the slightest faults of the interior of the glass. This phenomenon is the same as that which one can observe at home in the evening when a thin stream of water runs from a tap in a room lit by a lamp. The little stream of water is almost invisible but its projected shadow on the wall is as black as that of a pencil.

Here is the explanation of this contrast. The light which falls on the little stream of water traverses it to a considerable extent and, the remainder being reflected in all directions, only a very small part of it reaches the eye. On the contrary, the light which enters the stream of water is refracted in all directions and the part which reaches the projected shadow is very feeble; this shadow is thus very dark. In the glass the veins behave as does the little stream of water.

When very fine details are concerned, the shadows are rendered still more visible by an optical phenomenon, the theory of which cannot find a place in this work, diffraction. On account of diffraction, the actual shadow of a point is a small spot of appreciable diameter; the shadow of a stretched wire is larger than the geometric shadow would be and generally appears to be accompanied by two very fine parallel lines.

The method of examination by the projected shadow makes visible, together with the interior defects of the glass, all the surface defects.

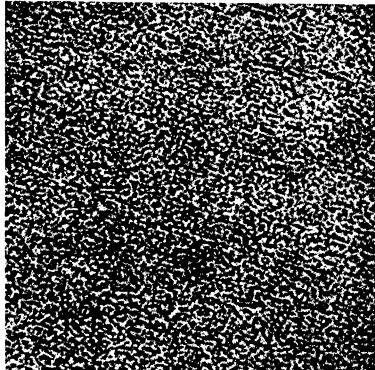

FIG. 7. Appearance of an imperfect polish seen in the testing apparatus.

Fig. 7 shows the projected shadow on a grey screen of a sheet of glass whose polish is defective. It shows the necessity of sufficiently polishing the faces of a piece of glass to be examined.

Fig. 8 shows, under the numbers 1, 2, 3, 4 and 5, the projected shadows, on a grey glass placed one metre from the glass under exa-

mination, of veins contained in this glass and invisible to direct observation. One also sees there several wide, dark traces surrounded by a border; these are diffracted shadows of fine sleeks on the surface.

A slightly more complex apparatus allows the observation of the same phenomenon with a stereoscopic effect; it is then very easy to locate in the glass the defects which one sees. This advantage is of

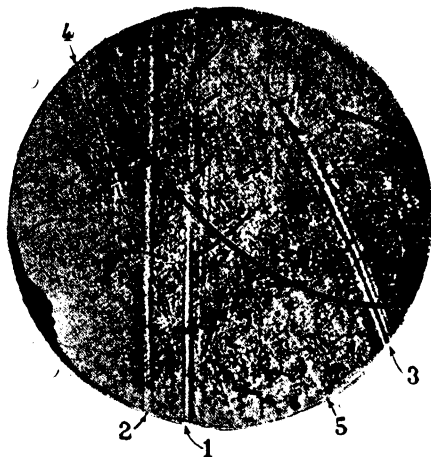

FIG. 8. Invisible veins and fine scratches revealed by the testing apparatus.

interest since it permits precise limitation of the defective parts which must be removed, in order to conserve as large a quantity of good glass as possible.

If one has no stereoscopic installation at one's disposal, one can nevertheless exactly locate a vein in a plate, by means of some fairly simple manipulations, in the following manner. The plate being in the first position  $P_1P_1P_1P_1$  (Fig. 6), one marks on the grey glass the shadow of a vein which one wishes to locate. With help of an assistant, a needle is moved along the entrance face of the plate until the shadow of the needle is projected upon the shadow of the vein. At this moment the needle is at  $A$  and the position  $A$  is marked on the glass. Similarly the needle is moved over the exit face and the position  $B$  is marked, from which the needle projects its shadow upon that of the vein. The vein lies in the section  $AB$  of the plate. Placing the plate in a very different orientation  $P_2P_2P_2P_2$ , one operates in the same way and finds that the vein is in a section  $CD$ . It will then be located at the intersection  $M$  of the sections  $AB$  and  $CD$ .

This method only requires that the plate shall have two parallel polished faces. The piece to be examined may be of any shape what-

ever; in particular, discs moulded for lenses may be examined so long as the circumference is polished. Placing the disc in two different positions, one determines, by the artifice of the needle, two chords which pass through the vein which is being located.

By the same method, surgeons locate, by means of X-rays, a bullet in the body of an injured person. They use X-rays in place of light rays and a fluorescent screen in place of a grey glass; the screen being sensitive to the X-rays, makes objects opaque to X-rays visible. The path of the X-rays arrested by the bullet is determined in each of two positions in which the injured person is placed.

It is convenient to place the point light source (Pointolite Lamp) at the focus of a convergent lens in order to obtain a more or less parallel beam of light which can be directed on the plate to be examined. This arrangement enables one to place the lamp close to the plate and condense the light, but it is not indispensable; it will suffice to place the lamp a little further off.

### **Examination of a Glass for Strain**

The examination of strain, being made by the aid of polarised light, will be treated in the chapter relating to polarisation. Let us, however, say at once that on account of the process of manufacture of the glass (blowing or drawing of white glass, or moulding in plates of optical glasses) the contraction due to too rapid cooling (strain) is much more accentuated when one examines through the width of a piece than through the least thickness. For this reason the plates should always be worked up by the optician in such a way that the axis of the lenses is perpendicular to the large faces.

## CHAPTER II

### ABRASIVES—GLUES, RESINS AND CEMENTS—TOOLS— POLISHERS

#### ABRASIVES FOR ROUGHING OR SMOOTHING

One designates under this name the different substances employed in a powdered state in the working of metals, glasses or crystals. They are used in larger or smaller grains according to the degree of progress of the work of grinding.

The principal abrasives employed in optical work are siliceous sands (grits), emeries, carborundum, diamond powder or dust, polishing rouge (colcothar and ferrous oxalate), cerium oxide (*rose à polir*), white Tripoli, pumice powder, putty powder.

#### Grinding Sands

The sands employed for working glass are fragments of silica, more or less pure, which have been detached from blocks of silica or from pebbles by the repeated action of natural elements (rolling of stones or of pebbles produced by the sea waves or by torrents). Those most used are sandstone grits. Sandstone is a more or less hard stone, according to its age of formation, resulting from the agglomeration of little grains of silica. (Crystallised silica takes the name of quartz. Quartz crystals play an important part in optics; they will be studied in the chapter concerning the working of crystals.) Fontainebleau sands are the most appreciated of silica sands; they are white sands composed of such pure silica that by melting them in an electric furnace the fused quartz referred to in the preceding chapter is manufactured.

The sandstone grit is used for roughing the shape of the glasses, that is to say, in order to give to their faces a rounded form, almost plane or deep, approximating to the optical surface to be realised. This grit, mixed with water, acts as an abrasive, with, as tools, plates (thick discs of cast iron turning about a horizontal axis), or convex or concave tools of cast iron.

For roughing large surfaces of slight curvature, one mounts the work upon the lathe and uses as tools little fire grates from domestic furnaces; the grit mixed with water falls between the bars of the grate and runs out as it grinds under the tool. The grating wears up little by little and at the same time as the glass in adapting itself to the shape given to the latter.

## **Emeries**

Emeries are little grains obtained by grinding a stone formed mainly of grains of corundum; they contain a little iron. Corundum is the hardest stone after diamond. It is colourless and anhydrous alumina (alumina is a compound of aluminium and oxygen).

Fresh emeries have a pale blue tint which changes to brown after use, on account of the formation of iron oxide by trituration with the water. They also contain a little silica.

They are sorted into emeries of different sizes; the largest known as 000, 00 and zero, have been sifted. Next come the graded emeries spoken of as 1 minute, 2 minute, . . ., 40 minute, 60 minute, up to 240 minute; but emeries of 120 minutes or higher are very little used. These designations indicate the time of decantation used in selecting them by the process which is to be described later. The coarsest of these emeries are sometimes obtained by sifting, but the emeries graded by minutes are more expensive than the sifted emeries and are better because they are better selected.

Emeries of doubtful origin are often mixed with softer materials which lessen their value. One must, then, apply to conscientious suppliers.

## **Selection and Grading of Emeries by Minutes**

The well-known process of sifting is only applicable to powders of sufficiently large grain size, for the finest sieves which can be made still have too large a mesh in relation to the grain size of emeries used for smoothing.

For fine powders sieves only serve to retain the little lumps into which they are agglomerated.

The process of selection used for fine emeries is that of levigation (or elutriation). It is based on the time taken by the grains to traverse a vessel of water 1 metre (1 yard) high and about 30 cm. (12 in.) in thickness. Everyone has seen how a stone arrives more quickly at the bottom of water than does fine sand. If one throws into water a spadeful of unsorted sand, the pebbles get to the bottom first, the medium sized sand next, and the very fine sand and mud cloud the water for a long time afterwards. This is the reason. Its weight, which makes a stone fall, is proportional to the volume of the stone, that is to say, to the cube of its dimensions. The force which retards its descent in the water is, to a large extent, a frictional force proportional to the surface of the stone, that is to say, to the square of its dimensions. When one doubles the dimensions the weight is multiplied by eight and the surface area by four. Let us imagine eight little cubes of 1 mm. side; they weigh as much as a single cube of the same material having

nm. sides. The surface of one little cube = 6 sq. mm.; the eight little cubes together have a surface of  $6 \times 8$  sq. mm. = 48 sq. mm.; while the surface of the large cube = 24 sq. mm. Thus when one throws the large cube and the eight little cubes (which together weigh as much as the large one) into the water simultaneously, the force which retards the fall of the little cubes is double that which retards the fall of the large cube. Thus, the large cube arrives at the bottom well before the small cubes.

After grinding, emeries of various sizes are mixed together.

About ten litres (18½ pints) are put in the vessel: water is poured on them and stirring is carried out for some time with a branched tool which serves to bring to the top of the vessel the emeries of all kinds deposited at the bottom. Then water is added until it overflows the vessel and carries off all the impurities which rise to the surface, thereafter it is left undisturbed for two hours. At the end of that time the water only contains 120 minute emery. This is decanted by opening a bung or a tap at about the middle of the height of the vessel (it is still better to make use of a very clean glass syphon). The water thus collected is poured into a very smooth and clean pot where it is allowed to remain for several days; at the end of this settling time the water is thrown away and the deposit is dried. This is the 120 minute emery. A new water is put into the 1-metre vessel to replace that which was run off with the 120 minute emery, and vigorous agitation is used to bring all the deposit at the bottom into suspension. This is then left undisturbed for an hour. At the end of this time the water only holds in suspension the 60 minute emery. It is collected by the same method as was the 120 minute emery. The same procedure is used for all kinds of emeries from the finest to the coarsest. In practice the decantation is repeated several times in succession for the same period of settlement, 30 minutes, for example, and each time one recovers some 5 minute emery which did not remain in suspension in the preceding water because it had been carried to the bottom by large grains of emery to which it was attached.

When the 1 minute emery is reached, the decanted water taken from the upper part gives emery "1 fine" and the second part gives emery "large". This selection between the minute emeries is facilitated by the existence of two other bungs; one at about 20 cm. above the central bung yields finer grains and another at about 15 cm. below the central bung yields larger grains.

#### Recovery and Washing of Used Emery

The emery mud which remains in the troughs of the lathes must be carefully collected and poured into a vessel of large capacity (a 100 litre (110 gallon) cask, for instance). This mud contains worn

emery together with the products of grinding from the glasses and the tools. The alumina and the iron oxide, which make up the emeries, have a specific gravity of about 4; the copper and the copper oxide which are derived from the wear of brass tools have higher specific gravities, but the silica which may be contained in the emeries and the worn glass powder have specific gravities of about 2.50.

If the treatment by decantation used for grading fresh emery is applied to these muds, the glass and silica powders and all the light fragments are easily eliminated, but the metallic powders, whether oxidised or not, for an equal size, fall much more quickly than the emery powders.

The preceding considerations justify the following technique. Beat up the mud in the vessel with a birch besom, cut short and brushy, in order to scrape the bottom of the vessel well, and let it stand for about five hours. Remove the upper third of the volume of water by decantation and throw away this water, which contains the light impurities. Replace the water removed by clear water. Repeat this operation from the beginning about ten times, each time stirring energetically in order to detach from the emery grains the fragments which remain attached to them. At about the tenth operation the water which is drawn off is clear; nevertheless it is still possible to remove some impurities as the operations of grading by decantation are proceeded with. For example, the water containing 5 minute emery in suspension having been poured into a vessel which is taller than it is wide, is allowed to stand for several days to obtain at the bottom a compact deposit. It is slowly decanted without disturbing the bottom and left to dry until it attains a certain consistency. It is known that the layer in contact with the bottom of the vessel must contain the greatest quantity of metallic debris, and the layer above it, in contact with the air, must be most charged with light impurities. The upper layer is removed to a depth of about one centimetre by means of a scraper and this material is put into the large vessel for further treatment. Then the upper half of the remaining deposit is collected. It is first quality 5 minute emery. The remainder, which is charged with metallic impurities, will be second quality 5 minute emery, but it is possible to eliminate the metallic residues from it almost completely by washing it with water to which, for example, sulphuric acid has been added.\* This acid forms soluble metallic salts which it is easy to remove by rinsing in several waters. The quantity of acid to be used depends on the amount of metal to be dissolved; one could try one-tenth of the volume of the mud to be purged. If, after rinsing, the water is no longer acid, it shows that all the acid has been converted into salts;

\* It is as well to remember that acid should be added slowly to water, not water to acid. (Trans.)

the water must then be renewed, a little more acid added and left for the reaction to take place, stirring from time to time to mix the deposit with the acidulated water. If, after several such manipulations, the water remains acid, as can be ascertained by putting into it a piece of litmus paper which turns red on contact with acid, it is to be presumed that the whole of the metallic residues have been attacked by the acid. It can then be rinsed with clear water.

Finally, it is well to rinse with a slightly ammoniacal solution to degrease the emery grains which might have come in contact with greasy bodies.

All these operations, of washing and grading, demand the greatest attention to cleanliness, in order to ensure that the grains of a certain number do not remain attached to the surfaces of the receivers and vessels so as to mix themselves later with finer emeries. That is why, whenever operations of grading, properly so-called, are concerned, it is recommended to employ only vessels which are easy to clean, of glazed earthenware, porcelain, or best of all, of glass. Bungs and taps which are difficult to clean and are capable of retaining emery grains, should be abandoned and replaced by glass syphons.

Everything that has just been explained on the subject of grading supposes that the powders which are to be sorted have the same density. If that is not so, the process of decantation is ineffective. Notably, if some carborundum is mixed with emery, the grading will have the effect of mixing with the emery some larger grains of carborundum. That is why muds which contain carborundum and emery together should be thrown away.

In spite of all precautions it is to be feared that some dirt may fall into the emery pots. In order to eliminate it, it is prudent to wash the graded emeries again from time to time and pass them through a very fine sieve of silk or brass which will retain all foreign bodies. It will always be preferable to wash with acidulated water, and then with pure water, to remove metallic impurities.

The optical workman chooses his abrasives in such a way as to obtain the best result as quickly as possible. To work hard substances one must have abrasives at least as hard; one can only work diamond with diamond powder. The softer materials are more easily scratched by hard abrasives. It is therefore necessary to choose the abrasives according to the materials to be worked, but the most rapid abrasives do not yield the best work. For cheap lenses one can adopt, in place of emery, carborundum powder, more biting than emery, but with which it will be more difficult to remove only a very small thickness of material.

### **Carborundum**

This is silicon carbide obtained industrially. On account of its low price it is sometimes used in preference to emery for working optical glasses, especially for the following operations.\*

- 1st, for trueing blocks of lenses of small diameter and short radius of curvature, when there is much material to be removed.
- 2nd, for trueing large pieces, when there is much material to be removed.
- 3rd, for charging saws (or slitting discs) in place of diamond chips.
- 4th, for making mills (milling cutters) serve for roughing deep lenses, as we shall see later. On grinding machines, carborundum wheels can also serve for trueing plane or cylindrical optical surfaces as one grinds pieces of metal. During the work a fine stream of water must flow over the wheel; but that is more a matter for the mechanic than work for the optician.
- 5th, for working quartz, carborundum is preferred to emery, because quartz is very hard and carborundum bites as well as diamond.

Carborundum is washed and graded in the same way as emery, but it is lighter (density 3.15 instead of 4). As a result of this difference in density the carborundum which, for instance, is still suspended in the water after ten minutes has larger grains than 10 minute emery. If, then, one wishes to be able to recover emery mud, working in the same workshop with emery and with carborundum is prohibited, since, if some carborundum were mixed with the emery, it would be impossible to separate them by washing and decantation. Some grains of carborundum will always be mixed with some finer grains of emery, and, in employing that emery, scratches would constantly be being made. All the facilities for washing emeries would be wasted if, by negligence, a little carborundum were allowed to get in.

### **Alumina Powder**

Artificial or natural corundum (crystalline alumina), reduced to powder and treated by elutriation, forms an excellent abrasive, more biting than emery because it is free from the impurities which emery contains (iron, silica, etc.).

### **Diamond Powder** (see Diamond, p. 248)

Diamonds which are not pure cannot be used for jewellery. The finest reduced to a powder are used as abrasive powder for working good diamonds. Optical workers also use diamond powder incorporated

\* In English practice carborundum is the principal roughing abrasive. (Trans.)

in fatty bodies (vaseline, beef marrow, etc.), and called *égrisé* (or *égrisée*). One can prepare it oneself by breaking small pieces of diamond with a hardened, tempered and polished steel pestle in a mineralogist's mortar,

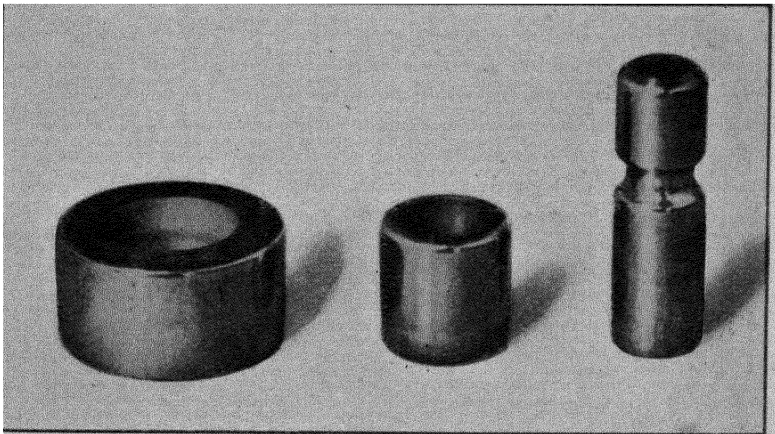
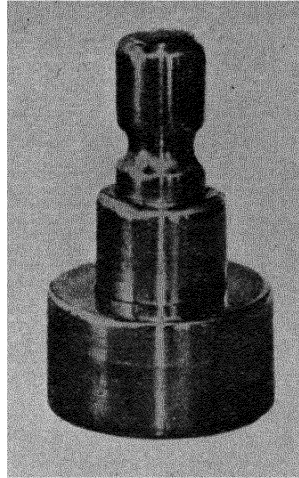

FIG. 9. Abich's mortar.

known as Abich's mortar (Fig. 9). The mortar, charged with material to be crushed, is placed on a solid support and heavy hammer blows are given to the pestle.

This mortar is composed of three parts: the mortar itself, the inter-

mediate socket and the pestle. Broken material which is thrown out can wedge the pestle in the socket, but there is very little chance for the socket to wedge itself in the mortar so the crushed material can be easily collected.

Diamond powder may be used for working hard crystals (corundum, ruby, jasper, etc.). Diamond cutters and lapidaries usually prepare it themselves in order to be certain that it is free from any mixture with cheaper materials; nevertheless the "égrisé" which comes from the mortar contains from ten to fifteen per cent. of steel originating in the mortar itself.

The powders studied in the foregoing are too hard for smoothing materials softer than glass, such as soft metals and certain crystals, fluorspar, calc-spar (or Iceland spar), etc. To execute the final smoothing on these metals recourse can be had to the use of powdered pumice stone, powdered whet-stone and powdered lazulite, the pumice powder still being the hardest of these stones.

All these powders are washed and graded by decantation as the emeries are, but obviously the numbers indicating the times of decantation do not correspond to the same grain sizes for the emeries and for abrasives of differing densities.

### **Pumice Stone**

This kind of stone is not perfectly homogeneous, so that even after it has been well ground, washed and graded, it can contain some harder particles. Thus pumice powder should only be graded in small quantities. The powders collected must be tried on some valueless samples of the material to be polished. If it produces light scratches, under heavy pressure, the powder should be rejected.

When polishing on paper use is also made of pieces of pumice stone, one face of which has been ground, to wear away either the edges of the paper or its central portion according to whether one wants to use the central zone or the annular zone of the polisher.

### **Whet Stones**

Known as: blue-stone, rotten-stone, Turkey stone, etc. These are very homogeneous stones with very fine grains, softer than pumice stone. They are powdered in a mortar and treated by washing and decantation.

They are also employed in shaped and smoothed pieces for smoothing, in their turn, metallic mirrors.

### Lazulite or Klaprothine

This is a blue stone, an hydrated phosphate of alumina, magnesia, iron and lime. It is employed in the same conditions and for the same work as the whet stones referred to above.

## POLISHING POWDERS

### White Tripoli

Tripoli is a natural silicious substance formed of microscopic algae (diatoms) and is sold in broken fragments of the size of a nut or an orange. For grinding, the least angular pieces which appear the soundest and are lightest for their size, are chosen. These are the most likely to be free from foreign bodies.

As in the case of pumice stone, it is best to grind only a small quantity at a time and to try each batch before passing it for use in the workshop.

White Tripoli is mainly used dry for polishing on paper. It is particularly suitable for hard materials and will even polish corundum. It is also occasionally used for rapid polishing on damp felt.

### Polishing Rouges

These are of two kinds.

(1) English rouge (known in Germany as French rouge) is colcothar, or peroxide of iron,\* which is obtained by calcining iron sulphate or green vitriol. It is a more or less fine powder, which is washed and treated as are fine emeries. After washing it is passed through a silken sieve, made of a fine *mousseline de soie* which is stretched on a funnel. A little rouge is thrown on it and a streamlet of water is run on while the rouge is stroked with a badger brush. It is well to prepare it of various degrees of fineness.

English rouge is very biting, even on quartz. It is thus indicated for rapid polishing, and it is employed especially in spectacle making with polishers of felt or cloth. It is used wet.

(2) Ferrous oxalate is a yellow chemical product which is obtained commercially. It cannot be used in its commercial state; it is necessary to submit it to a kind of calcination in the workshop, in order to convert it to rouge. For this a frying pan is employed in which the ferrous oxalate is spread in a uniform layer of about 1 cm. thickness. The pan is heated until the oxalate catches fire and the material is treated so that the whole mass becomes red. The substance is allowed to extinguish itself and cool. Finally it is washed and sifted as was the colcothar.

\* Red oxide of iron,  $\text{Fe}_2\text{O}_3$ . (Trans.)

This product is used dry or wet, but it is most particularly recommended for use in the wet state for polishing high quality surfaces on pitch polishers.

### **Cerium Oxide** (or *rose à polir*)

Cerium is the metal which is contained in the "flints" of automatic cigarette lighters. Its oxide is appreciated for polishing on automatic machines with pitch polishers, because, as this abrasive is very biting, the polishing is finished rapidly. It is less recommended for precision polishing because, precisely on account of its "bite", it is less suitable for removing infinitely small layers of material.

Like ferrous oxalate, it must be subject before use to calcination in the workshop, then to washing and sifting.

Calcination is done in a frying pan or on a sheet of iron placed on a furnace. The oxide is spread out to a thickness of two or three millimetres. While it is heated from below by the furnace it is heated above with a gas blow lamp until the whole layer has turned red. It is then left to cool.

### **Powdered Alumina. Diamantine**

Colourless or coloured (ruby) corundum, in extremely fine powder, is suitable for polishing fluorspar, aragonite and other crystals of similar hardness.

Diamantine is a brand of polishing powder with a basis of alumina, made in Switzerland. It gives to hardened steel a beautiful deep black polish which may be made brighter with a little oil.

### **Diamond Powder** (see above, p. 22)

Diamonds are polished with extremely fine diamond powder.

### **Alumina Silicate**

This is the basis of an excellent powder for polishing metals which is sold under the name of aluminous silica (*silice alumineuse*).

### **Chromium Sesquioxide** \*

This is sold under the name of oxide of chromium and is an abrasive that also can be recommended for polishing hard materials.

### **Putty Powder** \*

This is used for polishing soft materials, mirrors of soft metal alloys and certain crystals.

\* The industrial use of chromium oxide and putty powder is controlled by factory legislation in Great Britain. (Trans.)

Putty powder is oxide of tin obtained by calcining the metal. It is bought crushed to fine powder of the colour of mastic.

Before use, it is washed and filtered as polishing rouges are.

Putty is used wet exactly as are the rouges.

It is essential, in order that it shall work well, that it shall penetrate its support (cloth, taffetas or velvet) uniformly. Consequently some unwanted surfaces are first polished to prepare the polisher. The succeeding surfaces can be very well polished without the addition of any putty powder.

### GLUES, RESINS AND CEMENTS

Starch or starch paste is used solely for glueing paper polishers.

#### Observation on the Choice of Cements

Cements must be judiciously chosen according to the use to which they are to be put.

Like most substances, cements expand with heat and contract again on cooling. Hence when liquefied and used warm they exercise an action upon the homogeneity of the pieces which they serve to cement; therefore when pieces of small thickness, and above all thin plates, are prepared, the use of rapid hardening cements, such as certain wax cements, must be avoided. However, one can employ oil cements and Venice turpentine since these materials when warmed can be spread in very thin layers, and the thinner the layer the less risk there is of deforming the optical part.

When it is a question of constructing laboratory cells for optical tests, the choice of the cement to be employed to join the sides of the cell must be made in accordance with the liquids to be put into the cell. The cement must, in effect, be insoluble in the liquids in the cell. In a general way the liquids which dissolve gums (Seccotine, for example) do not dissolve resins (colophony, for example) and vice versa.

#### Optician's Cement, or Wax Cement

This is a mixture of yellow wax and rosin. First melt the rosin, add the wax in the proportion of about 1 part of wax to 6 of rosin and work up before leaving to cool. Very pure yellow wax (beeswax) must be used.

Optician's wax is useful for sticking a lens to any support; it can be unstuck by heating it very slightly.

**Oil Cement \***

Preparation is similar to that of optician's cement. Melt 900 gm. (36 oz.) of rosin and add to it 100 gm. (4 oz.) of olive oil. Work it up well. Strain it as black pitch is strained, and pour it into a paper box placed on a plate of sheet iron to accelerate its cooling.

This cement can replace pitch for making polishers.

**Three Cements for fixing Glass to Brass.** (*Fritsch.*, 1925)

*1st Formula.* Melt together

200 gm. of rosin (7 oz.)

4 gm. of wax ( $\frac{1}{10}$  oz.).

Later incorporate with the mixture:

15 gm. of moulding plaster ( $\frac{1}{2}$  oz.) (plaster of Paris).

*2nd Formula.* Boil together in 5 parts of water

3 parts of rosin

1 part of caustic soda

until a creamy soap of rosin is obtained.

Knead two parts of this soap and one part of plaster together. In this way a cement which hardens in one hour will be obtained.

*3rd Formula.* Melt together

4 parts of rosin

1 part of wax

1 part of colcothar (rouge).

Mix well.

**Serbat's Cement, for fixing Glass on Metal.** (*Fritsch.*, 1925)

Take:

10 parts of zinc oxide

10 parts of lead sulphate

7 parts of linseed oil.

Knead these materials well and incorporate:

20 parts of powdered manganese

2 parts of English rouge (colcothar).

\* Where in this and following formulæ avoirdupois weights are inserted they are not necessarily exact equivalents of the metric measurements but are designed to preserve correct proportions in whole numbers as far as possible. (Trans.)

Pound the whole for a long time in a mortar. Then again add:

20 parts of manganese  
 20 parts of English rouge (colcothar) or  
 in any case a sufficient quantity to  
 allow the mass to be rolled between  
 the fingers.

**Cement for Metal on Glass or on Stone.** (Dr. Ostwald)

Litharge	..	..	2 parts
White lead	..	..	1 part
Mastic (rosin)	..	..	1 part
Linseed oil varnish			3 parts.

Knead the powders with the linseed oil and pound the cement with a wooden mallet.

**Black Cement**

A mixture of black sealing wax with commercial black pitch in the proportion of about 9 to 1. First warm the wax, add the pitch and mix well together.

Black cement serves for sticking cloth polishers, for sticking mallets to lenses and for blocking. It adheres to warm metal and also to polished glass. A slight mallet blow must suffice to detach the glass. It is necessary, then, that the cement should be rigid enough to transmit the vibration of the blow deeply. On the other hand, it must retain a certain plasticity permitting the lens to accommodate itself slowly to the tool, even at the temperature of the workshop. This property is precious when, owing to excessive warmth or too great pressure, the glasses in a block are slightly tilted.

There is, then, an optimum proportion to be sought between the weights of the components, taking account of the quality of the pitch. By prolonging the cooking the spirit contained in the pitch is evaporated and the plasticity of the cement is diminished.

**Cement (or Mastic) with Spanish White,\* known as French Cement**

From one to five kilograms (2-11 lb.) of black pitch are mixed, warm, with eight kilograms (17 lb.) of well-ground Spanish white. Then twenty or thirty grams ( $\frac{3}{4}$  to 1 oz.) of candle grease (tallow) are added, in order to make the cement adhere better to glasses, and about ten or twenty grams ( $\frac{1}{2}$ - $\frac{3}{4}$  oz.) of white wax so that one can detach the glasses from the cement by a blow.

\* Spanish white is pigment obtained from chalk and used in paints, usually known in England as whiting. (Trans.)

This cement, less soft than the black wax, allows of surfacing under heavier pressures such as are employed in spectacle lens making. It resists rise of temperature better than black wax, but it has not enough plasticity to allow, as does the black wax, the glasses to mould themselves upon the tool during surfacing. It can also serve for glueing felts on to polishers.

### Shellac

A natural exudation from certain tropical trees.\* It is generally purchased in thin plates or laminæ. The optician uses it either as a paint or in sticks.

As a paint, that is to say, dissolved in alcohol, it serves for varnishing plaster blocks. To prepare this varnish a certain amount of shellac is placed in a vessel, enough alcohol to impregnate it thoroughly is poured on to the shellac and, if one wants to accelerate the solution, it can be heated on a bain-marie (hot-water bath).

Shellac is employed in sticks for blocking small lenses on tools of short radius. To prepare the sticks the gum is softened in boiling water; it is then squeezed together in order to form sticks which solidify on cooling.

### Shellac Cement for fixing Glass to Glass †

Melt 5 parts of shellac and add to it, very carefully, 1 part of turpentine. Five parts of pumice stone, very finely powdered, are incorporated in the hot mixture.

### Turpentine

Only the best white Venice turpentine should be used.

Do not heat it with a naked flame on account of the danger of fire. To melt it, put it in a glass vessel (avoid the use of metal), supported over a stove in such a way that the air circulates between the stove and the vessel.

If, after cooling, the turpentine can be easily depressed with the finger nail, it must be liquefied a second time. At the same time, warm the glass flask in which the turpentine is to be kept, in the stove. Place in it a glass funnel furnished with a filter paper that has been washed in ether. Pour the turpentine on the filter and close the stove again so that the turpentine remains liquid while being filtered, but keep the temperature low enough not to brown the turpentine.

Turpentine is used in preference to Canada balsam for cementing glasses or crystals destined for certain uses, since its absorption for

\* Or rather a purified excretion of the insect, *Tachardia lacca*, which feeds on these trees. It is variously sold as seed lac, shellac or button lac. (Trans.)

† *J. Fritsch., loc. cit.*

different radiations is not quite the same as that of balsam. It is also used to render smoothed (grey) surfaces transparent.

### Oil of Turpentine

Used as a lubricant when drilling holes in glass.

A little is added to polishing pitch when it has been overheated or when a more supple polisher is required for the surfacing of delicate materials.

### Waterproof Cements

For certain optical instruments it is necessary to form around the glasses waterproof joints which do not allow water or humidity to enter. Among this category of cements are marine glue and Massiat's cement.

#### Marine Glue \*

An exceedingly tenacious cement can be obtained by working according to the following recipe.

Para rubber (soft)	.. ..	100 gm. (4 oz.)
Benzole	.. ..	200 gm. (8 oz.)
Powdered shellac	.. ..	200 gm. (8 oz.)
Para rubber (hard)	.. ..	100 gm. (4 oz.)
Soft bitumen	.. ..	200 gm. (8 oz.)

It is heated cautiously until the solvent is nearly eliminated, first dissolving the para rubber in the benzole and then adding the rest of the ingredients. It is poured into flat dishes with greased sides. To use it the tablets thus prepared are warmed until they melt. (*Chemiker Zeitung*, 1891.)

#### Another Recipe

Heat in a large enough cauldron

11 parts of asphalte.

Add to it

2 parts of tar,

and stir ceaselessly to avoid the material boiling over. Remove it from the heat and add 280 parts of creosote. Stir it for ten minutes in order to mix it well. Pour the glue into barrels whitened with whitewash and let it cool for one or two days.

\* *J. Fritsch., loc. cit.*

**Massiat's Cement or Rubber**

Immerse in water a little pebble of quicklime; remove it when it has ceased to effervesce and wrap it in cloths. The lime heats itself and becomes reduced to an impalpable dust. Cut some pure para rubber into little pieces and melt it in an iron spoon, over a low heat, in order not to produce too much vapour. As soon as most of the rubber is reduced to a viscous material mix with it the lime powder in the proportions of 4 gm. (62 grains) of rubber to 5 gm. (77 grains) of lime.

After cooling, this cement has the consistency of soft wax, but it hardens on exposure to the air. It must, then, be freshly prepared and kept in a closed vessel.

**Colourless Cement for fine Glass Work**

Venice turpentine	..	..	..	..	1 part
Bleached shellac, reduced to powder	..	..	..	..	2 parts
Mastic (rosin) powdered	..	..	..	..	3 parts

Heat these materials together, and to the warm mass add a sufficient quantity of oil of turpentine to obtain a clear solution.

This cement can serve for fixing precious stones on a base of glass of the same colour, but may also be coloured to the same shade as the objects which one wishes to fix together.

**Transparent Cement for Glass \***

Dissolve in a flask

75 gm. (2½ oz.) of rubber cut into little pieces  
60 gm. (2 oz.) of chloroform.

The rubber being well dissolved, add

15 gm. (½ oz.) of finely powdered mastic (rosin).

The flask must be kept stoppered; it is put in a warm place and shaken from time to time. The cement is ready for use in about eight days.

**Cements with a Basis of "Soluble Glass"**

Soluble glass is a name given to compounds of potash or soda with silica.†

Mix washed and finely powdered chalk with a solution of soluble glass (water glass) having a density of 33° on a Baumé aërometer, so

\* *J. Fritsch., loc cit.*

† *E.g. sodium silicate or water-glass. (Trans.)*

as to form a thick plastic mass. A cement is formed which sets in from six to eight hours and acquires an extraordinary solidity. This cement is susceptible of numerous applications in industry and in domestic use.

The powdered chalk can be replaced by other materials and variously coloured cements can thus be prepared.

(a) Thus with antimony sulphate passed through a fine sieve, one obtains a black cement which, after setting, can be polished with agate.

(b) With finely powdered cast iron a dark grey cement is obtained.

(c) With powdered zinc a grey cement is obtained which acquires great hardness and which, polished with agate after hardening, takes on the sheen of metallic zinc.

(d) With basic copper carbonate, a light green cement is obtained.

(e) With chromium oxide a dark green cement is obtained.

(f) With cobalt blue a blue cement is obtained.

(g) With minium (red lead) an orange cement is obtained.

(h) With vermilion, a brilliant red cement is obtained.

(i) With carmine, a violet cement is obtained.

(j) By mixing with the solution of water-glass equal parts of powdered cast iron and powdered zinc, one obtains a dark grey cement, which acquires the hardness of stone on solidifying.

### New Cement for Glass \*

*La Nature* (1912) gives a recipe employing cellulose acetate, particularly for cementing glass destined for making cells to contain water, alcohol or ether. Two plates, for example, may be united by spreading the cement on the surfaces to be joined and keeping them under pressure until the solvent has disappeared.

The best results have been furnished by applying the following recipe:

Cellulose acetate	.. ..	5 gm. (77 grains)
Tetrachlorethane	.. ..	100 gm. (3½ oz.)
Methyl alcohol	.. ..	10 gm. (154 grains)

### Pitch for Polishers

Black pitch, Swedish pitch or Archangel pitch serves for making the most usual polishers for precision optical work.

It is a product obtained from resinous woods which contain oil of turpentine. It will not serve to make polishers as it is bought; it must be treated in the workshop. Heat it for about 24 hours over a low heat in an iron cooking pot in order to volatilise the greater part of the oil of turpentine (a little of it must remain); do not let it boil but only

\* *J. Fritsch., loc. cit.*

steam. If the pitch is allowed to heat for too long, one is obliged to add a little oil (turpentine) and stir it up well before straining it. It is passed through a sieve consisting of three pieces of silk muslin superposed, and collected in a paper box.

This pitch adheres strongly to hot metal.

Pitch polishers occasionally leave traces of dirt on the glass. This inconvenience is avoided by mixing with the pitch at the instant of its fusion a small quantity of glacial acetic acid.

### Paraffin Wax

This is employed for fixing glasses on to supports whenever a very slight adhesion suffices. Slight heating causes it to melt, which greatly simplifies unsticking. Traces of paraffin wax can be removed with a little petrol.

### Moulding Plaster \*

*Plaster Blocks.* This plaster is much used for making up blocks of thick glass objects (prisms, for example).

In order to block in plaster one employs special flat tools of cast iron surrounded by a ring of iron, or better still, of aluminium alloys, forming a cell in which the plaster is run.

On the edges of this cell one places three glass props immersed in the plaster and of equal height, in such a way that by their exterior faces they determine a plane on which all the surfaces to be worked will be aligned. The pieces to be worked are temporarily fixed by means of paraffin wax to a plane support of glass or brass having the diameter of the ring which forms the cell. When all the pieces are properly arranged and stuck to this support it is turned over and the glasses driven into the plaster until the support rests on the three props, the excess plaster running over the edges. When the plaster is well set, that is to say after 6 or 8 hours, the support is taken off after having been gently warmed to unstick the paraffin wax. When the glasses are sealed in the block, it is stripped a little by removing with a scraper one or two millimetres of plaster around the glasses, in order to make the surfaces to be worked conveniently "proud" of the plaster. If the glasses in the block are hard (boro-silicate, for instance), one can, without injuring the glasses, remove a thin layer of plaster with a wire brush. If the glasses are softer (flint) a depression can be formed in the plaster by running a little wax on to the first support around the glasses. Finally, the plaster is varnished with a layer of shellac, in order that the block may be readily cleaned.†

\* Plaster of Paris.

† A modified method is described in Twyman, *Prism and Lens Making*, p. 81. (Trans.)

Plaster is also recommended for sealing glasses into a mounting, since, because of its porosity, its contraction is not considerable, and it holds the glass well without deformation.

To detach from the glasses the plaster with which they are covered, the pieces are plunged into a very hot solution of sodium carbonate (water 9 parts, crystals 1 part).

When the pieces to be blocked already have one or two polished surfaces, those surfaces are protected, to isolate them from the plaster, by means of a layer of spirit varnish or, better, by a shellac varnish.

## TOOLS

### Supports for abrasives and mode of attack of abrasives

#### Slitting (Sawing)

For slitting plates of glass, the grains of abrasive are set in the sheet iron or iron wire tool which serves as a support for them. In disc machines diamond chips set in the edge of the disc are still used sometimes. Thus it is necessary that this disc shall be in iron or soft steel suitable for such setting, or of brass or copper.

Rapid setting is carried out in the following way. The chips are covered with fairly thick grease and put on the edge of the disc in the chosen part. Each is driven into the steel disc by a slight blow with a fairly heavy hammer, then the grease is removed.

Diamond cutters use copper discs 6 or 8 cm. in diameter and a few tenths of a millimetre in thickness. They charge them with diamond powder by rotating them firmly pressed against an idle cylinder of steel charged with diamond powder in grease.

The high price of diamond has led, in general, to its use for charging saws being abandoned.\* The emeries in which, nowadays, the disc dips insert themselves in the metal, which must be soft enough for that. One cannot slit with a disc of hardened or tempered steel.

In the same way for bow sawing, the wire (or wires) must be of soft annealed wire. Sometimes a two-ply wire is used so that the abrasive paste accumulates between the plies.

Hand sawing can also be done with a metal saw whose teeth have been replaced by a band of copper. The emery powder sets itself even better in the copper than in soft steel. When very hard material, such as quartz, has to be sawn, emery must be replaced by diamond. One can employ soft sheet-iron discs, described above, carrying chips set in their edges, or simply let the discs dip into the diamond powder instead of emery powder. Used diamond powder can be recuperated by levigation, as are the worn emeries.

\* Not in Great Britain. (Trans.)

Here is yet another method: the saw is made of a disc of soft sheet metal, 1 mm. thick and 30 cm. in diameter, or thereabouts. With a chisel, transverse nicks about 1 mm. deep are made from place to place in the edge of the disc; then, with a setting tool, the transverse burrs are flattened down, thus each nick is transformed into a little cell suitable to receive diamond powder. It is well to make this diamond powder oneself, by crushing in a mortar of hard steel some chips of black diamond (Carbonado) in such a way as to obtain a powder which is fine but not impalpable. This powder, mixed with a little grease, forms the diamond powder with which the little cells made in the edge of the disc are filled, with the fingers. The disc, thus charged, is slowly turned while pressing a hard stone (agate, for instance) heavily on its edge, slightly closing up the cells on the diamond dust held in them. The saw is then ready to work until the disc is worn down to the depth of the cells.

The disc and the bow string charged with emery, work in the manner of a true circular or straight saw; the parts of the grains projecting above the setting are the minute teeth of these saws.

With discs dipping into the abrasive, work commences before the grains are embedded, but these finally wedge themselves in as stones finish by sticking themselves in the mud in soft ground.

### Drilling

The principles of drilling are the same as those of sawing.

If it is desired to drill a hole of some millimetres or centimetres diameter in a plate of glass, a tube of a not very hard metal such as iron, mild steel or brass is used. As opticians generally have a varied stock of brass tubes those are used, since it is necessary to choose them exactly according to the diameter which one wishes to obtain. The outside diameter of the tube must be from 0.1 to 0.2 mm. smaller than that of the hole to be drilled.

The tube being mounted on the lathe and set in rotation, its extremity is coated with a mud of No. 1 emery,\* and the glass is pressed against the tube in the place where the hole is to be drilled. The tube acts exactly as does the disc on a slitting machine.

If a hole is required to be drilled quickly in a hard stone or in order to detach a circular ring from it, a tubular tool is charged with diamonds as one charges slitting discs. For this purpose one places a layer of greased diamond powder on the plane surface of a block of hard steel. The edge of the tube is pressed on this layer and by light hammer blows on the other end one embeds the diamond dust in the lower edge of the tube.

The drilling of small holes (which is principally a spectacle making

\* Or carborundum.

operation) is executed with diamond drills or tool steel drills. The snags to avoid are splitting the glass or chipping the edges of the hole.

In order not to split the glass, it is sufficient not to bear too hard on the drill.

It is more difficult to avoid chips. A beginner will do well to stick glass protectors on either side of the glass to be drilled and drill through the three thicknesses at once, when the little chips which may be made are located in the protectors.

If one drills without protectors, a blind hole must be made and the glass turned over so that the drilling is completed in the opposite direction and the meeting of the two holes occurs in the middle of the glass. It is also good to give the drill, during the drilling, a very slight conical movement so that the hole has the form of two truncated cones

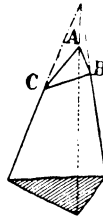

FIG. 10. Drill.

joined by their smaller base. In this way the sides of the larger bases, since they no longer grip the drill, have no tendency to chip.

Diamond drills should rotate at about 1800 revs. per minute. Steel drills should not turn at more than 800 revs. per minute.

During the work, oil of turpentine is used as lubricant.

One can make a good drill (Fig. 10) with a piece of a watch-maker's file which is ground to a very tapered triangular pyramid. Then an oblique section  $ABC$  is made. It is the edge  $AB$  which must attack the glass.

### Observation concerning all Rotating Tools

In order that the tool does not act on the work in a series of blows and in order that the lathe shaft is not worn irregularly, it is indispensable for the tool to be well centred on the lathe.

Cone mounting is indicated in order to obtain good centring automatically. The screwed boss on the tool, instead of springing from a flat shoulder, emerges from a convex conical shoulder (Fig. 11). The threaded extremity of the lathe shaft also projects from a convex conical shoulder. The intermediate socket, between the lathe shaft and the tool, presents at each end a concave truncated cone of the same shape

as the convex, truncated cones of the tool and the lathe. Its thread must have plenty of play with respect to the male threads, in such a way that the centring is done by the conical shoulders and not by the screw threads.

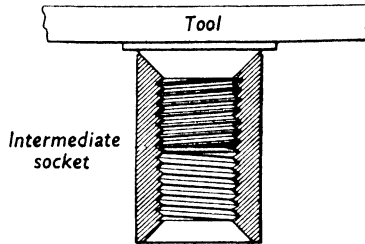

FIG. 11.

In order that the grip is not too powerful it is recommended that the tool be tightened by hand on the stationary lathe. By tightening it on the moving lathe a regrettable wedging is produced.

Obviously the intermediate sockets which may be interposed between the tool and the shaft must be of the same type, with truncated cones.

### Roughing and Trueing Tools

For roughing with sandstone grit,\* as well as for trueing with emeries 1-3 and 5, concave and convex tools of cast iron are employed (Figs. 16 and 17), since, if the grains of emery embed themselves too easily in a too soft metal, the tools will soon be unserviceable. On cast iron the large grains roll and their corners easily penetrate the glass by little shocks, which produce a characteristic grinding sound.

For reasons of economy in tooling, for trueing with coarse emeries use is often made of cast iron "calottes",† double-sided curved tools drilled with a central hole in which the boss which serves to guide the tool on an automatic machine is cemented. According to whether the boss is cemented to the convex or concave sides, the same "calotte" will serve as a concave or convex tool.

The roughing of small convex glasses of strong curvature can be done by mounting them on a lathe and turning them to fit a template, like a piece of metal-work. One employs for this work ordinary files of medium coarseness for roughing and with slightly finer cut for trueing if one wishes to dispense with trueing in a concave tool.

\* Carborundum No. 80 or No. 180 is used for roughing in this country. (Trans.)

† Literally, shaped like a skull-cap. The translator does not know of any English equivalent name for this French tool.

One can rough and true small convex lenses on *plateaux à caillebotter* (scouring plates).\* These are cast iron plates whose use is described in the following chapter as well as the use of the mills which serve for truing small concave lenses.

### Blocking Tools

Blocking tools are of cast iron and are lighter than surfacing tools, since their surface remains rough, and one will not use them to make to curvature or to correct it. The choice of their dimensions is important. In principle, the supports for the glasses can be a little less open than the corresponding surfacing tools, since it is well for the tools to be larger than the glasses or the blocks which they must surface. The opening should, if possible, allow an interval between the lenses of about three millimetres to be left when blocking in order that the sponge may be passed between them to remove the emery grains properly.

It is necessary that all the lenses blocked rest on an equal thickness of cement. If, for example, the central lenses rest on a thicker layer of cement than do those at the edges, the glasses at the centre will give way at once under the pressure of working and will grind less quickly. A thickness of 2 to 3 mm. of cement must be obtained. Thus the radius of the blocking tool (concave) must be equal to the sum of the radius of the surface to be obtained and the maximum thickness of the glasses, plus 2 or 3 mm. for the cement.

The radius of a convex blocking tool must be equal to the radius of the surface to be obtained, less the maximum thickness of the glasses and 2 or 3 mm.

It may happen that, having a pair of tools of the desired radius for surfacing, one has no blocking tools corresponding to them. In this case the glasses can be blocked on one of the surfacing tools (true tools) observing the precaution of slightly modifying the form of the tool on which the block is to be made. This modification is performed by means of rings of tin foil which are hot glued on to the tool in several stepped thicknesses. For example, let us suppose that one wishes to block some concave lenses of 100 mm. radius of curvature in the concave member of a pair of tools of 100 mm. radius and  $120^\circ$  aperture. The thickness of a lens and the cement on which it rests will be about 8 mm. An easily made calculation shows that the concave tool will be too deep by 7 or 8 mm., or, in other words, if the block were made on the bare tool there would be 2 mm. thickness of cement under the

\* There is no exact equivalent of "caillebottage" or "plateau à caillebotter" in normal English practice. Since its action resembles to some extent the scouring action by which pebbles are rounded in a pot hole, the terms "scouring" and "scouring plate" have been adopted in this translation. (Trans.)

lenses at the edges of the block and from 8 to 10 mm. under the central lenses. To make up this difference of 7 to 8 mm. a "cuirasse" is constructed from a circular sheet of tin of 2 mm. thickness and about 50 mm. diameter, covered with a second disc of tin of 80 to 90 mm. diameter, itself covered with a third disc of 1 mm. thickness and 110 to 120 mm. diameter. The three discs are glued with a hot cement and squeezed down like wafers by rolling the 100 mm. convex tool on them. It is on the 100 mm. concave tool, thus prepared, that the lenses are blocked and all rest on a backing of cement of sensibly uniform thickness.

A similar "cuirasse" is stuck on the convex tool if it is to serve for blocking convex lenses of a radius a little shorter than that of the tool.

### Tools for Working to Thickness (trueing) and for Smoothing

For trueing (using 10 minute emery) and for smoothing (using finer emery) the metal used must be sufficiently soft, perfectly sound and homogeneous; that is to say, free from the slightest cavity in which abrasive can collect and of which no part is harder than the neighbouring parts. For working precision lenses one uses brass tools, but the upkeep of a large range of optical tools in brass is costly, and it is economical to employ cast iron tools which can smooth almost as well, so long as the iron is of suitable quality. That is what is done in spectacle lens workshops. The quality of the cast iron does not only depend on its composition (there are numerous kinds of cast iron), but also on the care taken in pouring it.

Here is the composition of a cast iron from Pont à Mousson which is very suitable for making optical tools.

Materials in addition to iron	{	silica ..	.. 2.3 to 2.5 per cent.
		phosphorus ..	.. 1.7 per cent.
		carbon ..	.. 3.5 per cent.
		manganese ..	.. 0.5 per cent.
		sulphur	≤ 0.06 per cent.

It is a soft, close grained cast iron; it must be poured very hot, without splashing, in a well-dried mould; annealing improves its quality. But the precautions of manufacture are so detailed and so indispensable that cast iron tools must only be ordered from approved founders.\*

Too hard or inhomogeneous metal gives rise to scratches. In order to surface without scratches it is practically essential that the support for the abrasive should be softer than the object to be surfaced in order that an oversized grain of abrasive may penetrate into the support

\* Twyman, *loc. cit.*, recommends Meehanite. (Trans.)

rather than penetrate deeply into the glass. So long as tools which are less hard than the piece to be surfaced are employed, one is assured that in working, for example, with 30 minute emery whose grains are less than  $40 \mu$  in diameter, one will not attack the glass to a depth of more than 10–15 microns, even with very heavy pressure. The less the difference in hardness is between the piece to be surfaced and the support for the abrasive, the more one is liable to get scratches. All workers have observed, indeed, how, with the same tools, it is more difficult to surface the more delicate materials than the harder ones.

Smoothing tools must have sufficiently thick edges (about 10 mm. for radii of curvature of about 50 mm.). If the edge were too thin it would heat up, and expand more than the centre, as a result of the friction. Moreover, a good thickness allows of correction of the curvature of a worn tool or of giving it another, slightly different, curvature, while still conserving a sufficient thickness at the edge.

### **Wear of Emeries in the Tools**

Scratches can only be avoided at the price of meticulous care. Thus, before passing from an emery of one grade to the next, it is well to examine the tool carefully to assure oneself that there is no small cavity in which a grain of emery could have lodged, to come out again among finer emeries. Even this examination is not always sufficient. If, in spite of all the precautions that are taken, scratches still come, it is necessary to work the tool on its counterpart for a few moments, to try to find, by the aid of a powerful magnifier, the origin of the scratches and remove the grain which is the cause of the trouble.

The embedding of emery grains in brass tools is indicated by the characteristic brown colour which used tools assume; this colour is due to the embedded grains of emery.

When two new tools are worked together in order to correct their surfaces, the emery only bites on the "high spots", which are the first to brown. These are the only ones into which the grains of emery have penetrated. It can be assumed, without grave error, that the truing-up is finished when the two tools have acquired a uniform brown tint all over.

That is not to say that the grains of smoothing emery only work from the moment when they are embedded. It is certain that they roll for a time before finding a lodgement in the tool, and while they roll they are not without effect on the glass, but, from the much greater resistance which the workman feels with his hand when the layer of emery has become very thin, he senses that the really efficacious work does not commence until that moment, and at the end of the "wet"—*i.e.* before the interruption necessary to add some water or renew the

paper. After the moist emery has been laid on the tool, the first passes of the work only serve to spread the layer of emery all over it, and to equalise its thickness, which must be very low during the effective work. For that the abrasive paste must be kept in a certain optimum state of humidity which can only be judged from experience. If the paste is too thick and dry one will not be able to spread it sufficiently, its thickness will not be uniform, and the tool itself will work as if it were badly surfaced. If the paste is too dry, though not too abundant, several grains can mass together and scratch the surface. If the weather is dry and hot the abrasive pastes become dry too quickly. A suitable humidity must be maintained without stopping the work; the employment of a spray (or vaporiser) is very suitable for that.\*

If one region dries before another, it wears too quickly. The regions which become exposed dry more quickly than those which are never exposed; hence the tool must be so guided that the parts of the tool which become exposed are brought back on to the parts of the glass which are not exposed and vice versa. In Chapters III and V will be found an indication of the overlap which assures a good mixture of the abrasive paste.

When one has arrived at the final smoothing, one "refines" the emery. This operation consists in prolonging the work of smoothing without adding any fresh abrasive, but augmenting the pressure a little, in order to crush the emery grains well, to wear them down and cause them to penetrate into the tool. A "refined" emery behaves like a still finer emery. The mechanism of "refining" is set forth in Chapter III.

### Grinding Wheels

The use of grinders, for long in general use in precision mechanical workshops for correcting plane and cylindrical surfaces, is being extended more and more into optical workshops, not only for roughing and trueing glasses and for edging them (see Chapter VIII), but even for smoothing (see Chapter III) cylindrical surfaces or small spherical surfaces.

Wheels of varying fineness are required according to whether roughing, trueing, smoothing or edging is to be done. The wheels must be perfectly balanced and turn without vibration or play, preferably between centres, at the speed indicated by their supplier.

Before using a wheel the part of the circumference to be worked with must be carefully turned with a diamond.

The wheels consist generally of a carborundum agglomerate, but wheels of hard Scotch grit are specially appreciated. It is important to choose wheels of a good maker.

\* Or Plateau's solution may be used. (Trans.)

## POLISHERS

The necessity for a soft and supple support for the abrasive is more imperative for polishing than for smoothing; thus polishing powders are not used on metallic supports except for polishing diamonds or very hard stones.

The polishers in current usage are of felt, cloth, taffeta, pitch or paper.

### Felt

This is only used in spectacle lens making and for large blocks of slight curvature.

### Cloth

This is used in spectacle lens making for lenses of deep curvature (meniscus lenses). With wet rouge (colcothar) as abrasive a good polish is obtained rapidly without much danger of scratching, since this fairly thick polisher is supple and retains a sufficient quantity of water to maintain its humidity for a long while. One selects for cloth some cuttings of smooth cloth without roughness (suitings). Billiard cloth is excellent and even allows of well finished work. Moreover, the thinner and finer the cloth is, the better the surface it will yield. Excellent results can be obtained with worn silk velours, that is to say with a short pile, so long as the wear is uniform.

### Taffeta and Velours

Finer than cloth are the taffetas and especially silk taffeta. They can be used to polish precision surfaces. Notably they are used for polishing, with putty powder, metallic mirrors, pieces of Iceland spar (see p. 239), and in general for polishing delicate materials with putty powder.

### Cementing Felts, Cloths and Taffetas

All felts and cloths suitable for polishing must yield enough to mould themselves into deeply curved concave tools; that is what is known as "forming" (literally, wafering). To form the cloth, heat both the concave and convex tools to about 200° C., wet the cloth, stretch it between the concave and convex tools, press down with the convex tool while stretching the cloth to avoid creases until it is, so to speak, sheathed between the concave and convex tools. Remove the cloth without deforming it. To cement the cloth, take a tool whose curvature differs from that to be produced by about the thickness of the cloth, and cover with a suitable cement either the concave or convex tool, according to whether a convex or concave shape is to be obtained.

If spectacle lenses are to be worked in the block, one uses the cement with Spanish white in it, a small amount of which is poured hot and spread on the tool to which one wishes to cement the cloth. The formed cloth is taken up on the cooled counterpart and applied to the cement, pressing hard enough to squeeze the excess cement out at the edges.

The Spanish white cement has the advantage of not softening so easily as the black cement, so that it resists well heavy pressures and the heating that rapid production, such as that of spectacle lenses, involves. Black cement, which is more supple, is preferred to it for surfacing precision lenses.

Taffeta is treated in the same way as cloth. If the taffeta is thin and the curvature deep, the taffeta may not "take" enough for forming; in such a case one cuts it into strips between which small spaces are left. After sticking it, the cement which fills the spaces is carefully removed.

If one wishes to use, for making a polisher, the tool which has served for smoothing the surface which it is proposed to polish, a rather thicker coating of cement must be applied underneath the cloth in order that the cloth can fit itself to the smoothing tool over the whole polisher surface. In this case the cement layer is a little thicker at the centre than at the edge of a convex polisher, or a little thicker at the edge than at the centre of a concave polisher. That little difference should be avoided for precision work.

### Pitch Polishers

There are different methods of making pitch polishers for different purposes.

*Concave Polisher of any Diameter.* Warm the concave tool to about  $100^{\circ}$  or  $60^{\circ}$  C. If the tool is not more than 20 cm. in diameter, it is heated with a blow lamp. Pour into the hot tool enough pitch to form a regular layer about 4 or 5 mm. in thickness. To obtain the curvature, press on the pitch the cold convex tool lightly covered with the polishing powder to be used. To see whether the curvature obtained is centred, the convex tool is removed, the pitch is moistened a little to give it a reflecting surface and one watches the image of a light source in it, which must appear stationary if the surface is centred.\* If this is not so, its position is modified by pressing the convex tool suitably on the till soft pitch. One must work quickly to finish the operation before the pitch has solidified.

The following method assures correct centring without trial and error. Choose three or four little steel balls or even small blocks cut from a sheet of brass having the thickness which is to be given to the polisher. Place these balls spaced out on the circumference of the

\* It is to be assumed that the tool is revolving during this test. (Trans.)

polisher and press with the convex tool until it rests on the balls or blocks; which are finally removed.

When the pitch has become rigid, one can hasten its cooling by plunging the polisher into cold water, but it must be removed before it becomes quite cold in order to true it up with the smoothed block which will give it exactly its curvature.

If, instead of a block of lenses, a single large lens is to be polished, the operation is simpler. It suffices to mould the polisher on the smoothed lens without using the convex counterpart of the concave tool used for smoothing. This is because, effectively, the smoothed glass is not exactly of the same radius of curvature as the convex tool. By moulding the polisher on the convex tool one would obtain a polisher that is slightly too curved. These little differences arise from the fact that in truing up a pair of tools of the same nominal value, one obtains a difference between their radii of curvature of the order of the thickness of the last layer of emery used.\* The difference is less if the work has been finished with 10 minute emery than if it has been finished with 5 minute emery. Naturally, it is more appreciable on surfaces of deep curvature, and it is revealed on observing that the lens is worn away first at its centre when, in smoothing, one emery has just been replaced by a finer one.

*Plane Polisher of Large Diameter.* Warm the flat tool, and surround it with a paper rim strongly cemented with starch paste. Make sure that the axis of the lathe is truly vertical and the flat tool is truly normal to the axis (one confirms this by rotating the lathe). Pour the pitch on and let it spread by itself. Its surface will become almost plane and horizontal; it will not be exactly so because the pitch sets too quickly; the surface of the polisher must, then, be corrected by moulding on a plane tool, following the technique described for concave polishers.†

*Convex Polisher of any Diameter.* In the counterpart of the convex tool which must be transformed into a polisher—that is to say, into its concave tool—cold and sprinkled with polishing powder, the desired quantity of pitch is poured. On this the convex tool, preferably warmed to 50° or 60° C., is pressed; the pitch adheres to it immediately. The convex tool is then screwed on the lathe to examine with a light the centring of the polisher which has just been made. If the centring leaves something to be desired, it is corrected by pressing the concave tool with suitable lateral pressure. One can avoid this trial and error work by the process, using balls or plates, indicated for concave polishers.

\* See also Twyman, *loc. cit.*, p. 61. (Trans.)

† In English practice, the polisher is usually stamped with a pattern of squares on which reticulations formed from mosquito net are superimposed. See Twyman, *loc. cit.*, p. 49. (Trans.)

### **Pitch-wool Polishers**

Pitch polishers have the drawback of lack of rigidity; they deform from the effects of prolonged pressure and of too high a temperature. Their rigidity can be increased by incorporating in the pitch some perfectly clean cotton wool free from foreign bodies; chemists' absorbent cotton wool is perfectly suitable. A bundle of cotton wool large enough to cover the concave or convex tool which is to carry the polisher is thrown into the pitch, heated to the temperature at which it becomes quite liquid. This cotton wool is bathed in the pitch, stirring it with a stick until it is thoroughly impregnated. The bundle of wool is removed, most of the excess pitch is pressed out with the stick, and it is deposited on a cold flat tool where it is compressed with another flat tool in such a manner that as much pitch as possible comes out. A cake is thus formed whose centre consists of pitchy wool and whose edges are of pure pitch.

When the cake is cold one removes the periphery (of pure pitch) and only retains the central portion consisting of pitch-saturated wool. This part is broken into pieces, of the size of a finger nail, which are used for making a polisher. The concave or convex tool which is to carry the polisher being warmed, it is lined with little pieces of pitched wool which soften on contact with it, and this polisher is moulded with the cold counterpart of the tool exactly as an ordinary pitch polisher would be formed.

Pitch-wool polishers are specially to be recommended for making deeply curved polishers. Such polishers of 3 cm. radius, for instance, can each polish a large number of blocks without deformation.

### **Pitch-cloth Polishers**

A rapid and sufficiently precise polish is obtained by combining the processes of cloth and pitch polishing. The cloth is well soaked with hot pitch, which serves on one side of the cloth to make it adhere to the tool and on the other to receive the polishing rouge.

Brown Swedish pitch, boiled and passed through muslin, should be used. One part of pitch and six parts of turpentine are to be mixed and left to dissolve for 24 hours. The cloth is soaked and spread out to dry.

### **Waxed Cloth Polishers.** (American Optical Co.)

Use pure beeswax, cook it for more than an hour in a saucepan, mixing it intimately with rouge.

Prepare the waxed cloth in the same way as the pitched cloth. It adheres very well to a warm tool. When the tool has almost cooled, place it on the machine with a smoothed lens and set the machine in

motion for a few moments so that the dry polisher moulds itself upon the smoothed lens. Continue the work, moistening the polisher a little.

The speed of the machine should be 325 revs. per minute for lenses 50 to 60 mm. in diameter.

### Oil-putty Polishers

These polishers are sometimes used, as well as pitch polishers, for surfacing the same glasses. They are prepared in the same way.

### Paper Polishers

Paper polishers are suitable for precision surfacing of planes and slightly curved surfaces.

Paper polishers are the only ones which are worked dry, and it is an appreciable advantage not to have to preoccupy oneself with maintaining an even humidity all over the surface of the polisher.

There are some cases where it is not possible to obtain the necessary swing of the tool to assure a good mixing of the moist paste; some kinematic causes, which we shall study later on, can oppose it. In these cases, polishing on paper is specially indicated.

Several kinds of paper can be used, excluding coated (glazed) papers. The paper known as "Berzelius" is particularly suitable, but all blotting papers that are not thick and are solid enough, can suit if they do not contain dust or small foreign bodies likely to cause scratches. These papers have the peculiarity of presenting a kind of down when they are brushed. This fine down, retaining the abrasive grains of rouge or white Tripoli, and preventing them from rolling, gives a polisher which works after the manner of emery paper, but with an abrasive 20 to 40 times finer than the finest emery papers. When the polisher must be curved it is cut into rings. The paper is stuck down with starch paste well strained to ensure that it contains no clots. It is spread on the concave or convex tool in a thin, sufficiently fluid layer and then with a squeegee (a piece of glass with rounded edges) the excess of paste is squeezed out. The paste between sectors is carefully removed and the whole surface of the polisher is washed. While the paper is still damp it is brushed with a toothbrush in order to raise the down of the paper and is then dried by heating the tool underneath. The paper being dry, it is examined with a magnifier, in order to remove any roughnesses from it with the point of a knife.

Whenever there is a need to reduce the thickness of the paper locally, it is done by rubbing it with a smooth piece of pumice stone.

Polishing with Tripoli on paper, and dry polishing in general, occasions, now and then, a chattering of the glass on the polisher and causes bad working. The hand worker modifies the pressure which he exer-

cises when the chattering sets in. Automatic machines cannot do this so much and that is why paper polishers are only used in hand working.

### **Special Tools and Polishers for Large Surfaces**

For working large surfaces many reasons make it obligatory to place the tool on top of the work. These reasons arise from the following necessities.

- (1) Necessity of mixing up the abrasive paste over a large area.
- (2) Necessity of keeping an equal humidity over the whole of that area.
- (3) Necessity of supplying new abrasive without too frequently removing the tool.
- (4) Necessity of not exceeding the maximum pressure per square centimetre, in spite of the necessarily great thickness of a large tool.
- (5) Necessity for as much greater rigidity of the tool as its diameter is greater.
- (6) Necessity for a very small overlap in the stroke, a result of the kinematic reasons which will be studied further on.

For feeding in water and emery the tool is pierced with several feeding holes into which is dropped, from a dropper, either pure water, a mixture of water and emery, or water charged with polishing rouge.

In order that there may be reserves of abrasive all over the tool it is divided into squares, by grooves of semicircular section which cross one another, spaced 25 to 30 mm. apart.

In these grooves the excess of abrasive paste takes refuge and runs out again as the need for it arises. The semicircular section of the grooves lends itself to ease of cleaning when the grade of emery is changed. Such tools are not suitable if placed under the work since the paste does not run out from the grooves. These grooves have, too, the advantage of allowing the polisher to improve itself in the course of working. Let us suppose that one square is "proud" of its neighbours by a few microns; it will sustain a greater pressure and become warm; the warmth will soften the polisher and it will subside into the grooves which surround it.

To increase the diameter of the tools without exceeding the maximum weight and the limit of flexure that is imposed, webbed tools are employed, and brass (density 8.4) is replaced by an aluminium alloy (density about 3).

Polishing is also carried out with polishers cut into squares. On to a support of aluminium alloy is poured a layer of rosin which is moulded into squares of the dimensions indicated above. The spherical form is obtained by application of the polisher on a glass or a tool

of the desired curvature. Over the rosin a very thin layer of yellow wax is spread. With a polisher working with wet rouge, the pressure of 7 gm. per square centimetre must not be exceeded.

## CLEANING

### Sponges, Dusters and Brushes

Hard sponges (Levantine sponges) are reserved for removing coarse emeries from glasses and tools. The finer ones (Syrian or Grecian sponges) must be kept for fine emeries; the softest are suitable for pumice powder.

Before use, new sponges must be hammered with a small mallet in order to break and detach the little stones which may be included in them. They are carefully washed and rinsed.

It is essential that sponges should not be mixed. In principle, a sponge that has served for an emery of one number must not serve for another number. In the same way a sponge that has been used for carborundum must not be used for anything else. Meticulous attention to order and cleanliness are absolute essentials in an optical workshop.

For cleaning glasses fine dusters are used. Used cotton (linen) handkerchiefs are very suitable. By moistening them with a little petrol, alcohol (methylated spirit) or ether, the adherent pieces of dirt are easily removed, the glasses being subsequently dried with a dry duster. Well degreased chamois leather is also suitable for drying glasses. Optical workers have a habit of wiping glasses with the skin under their forearms but the skin must not be damp.

For simply removing dust which has fallen on the glasses one uses very soft brushes analogous to a barber's shaving brush.

Vinegar (or acetic acid diluted with water) serves to remove from the smoothed glasses the dirt which the abrasive has left on them and which must be removed before polishing.

Certain glasses, such as extra dense flints, are lightly chemically attacked by the abrasive. The greyness which results from this attack is avoided by adding about 10 per cent. of vinegar to the water which is mixed with the abrasive.

Methylated spirit, spirits of wine, rectified alcohol (at 70°) and benzene are all excellent for removing grease from the glasses.

Methylated spirit is a good remover of shellac.

Benzene serves particularly for dissolving traces of black cement or of rosin which may adhere to the glass.

If for blocking glasses in plaster one has previously covered them with a spirit varnish, they must be cleaned with alcohol after removal from the block.

## CHAPTER III

### SURFACING

*(In this chapter will be found several laws enunciated without proof; the rather delicate proofs are brought together in Chapter V)*

#### **The Surroundings**

The danger of scratching the glasses in the course of surfacing requires the most meticulous cleanliness and order to avoid the accidental mixture of abrasives of different grades or the descent of grains of dust on the tools. The floor, the walls and the ceiling of the workshops should be smooth, easily washable and covered with high-gloss paint. Preferably this paint should have the colour of red marble up to a height of two metres (six feet) because this decoration is less soiled by polishing powders. Glazed skylights in the ceiling are to be absolutely proscribed since dust accumulates in their corners and the slightest breath of wind projects it into the workshops. One can cite as a model installation that of the optical workshops of l'Atelier de Construction de l'Artillerie at Puteaux. There are no windows, properly so called, but an immovable, sealed glazing. Only air filtered by a special ventilator gets into the rooms. Large pipes situated in the corners of the rooms lead in the filtered air and remove the stale air. Thus the dust and smoke of the factories have no access to the optical workshops. The machines and the floor are entirely covered with thick linoleum, which allows of easy washing, and upon which the glasses can fall without too much risk of breakage or scratching.

These precautions would be illusory if the workmen brought in with them the dust or mud of the roads. The personnel cannot get into the workshops without passing through the cloakroom, where they change their outdoor shoes for workshop shoes and put on their working clothes. A boiler suit is very superior to the white flowing overall still in use in old-fashioned optical workshops. It is imprudent to wear flowing robes in the neighbourhood of gearing and belting.

Along the walls of the workshop and in the shade should be situated little alcoves into which the workmen can go to examine under artificial light the glasses which they are in course of surfacing. These alcoves should be lit with more or less monochromatic light (coloured electric bulbs, or, better, a mercury vapour lamp) for reasons which will be found in Chapter VI.

Finally, it is necessary to maintain a constant temperature in the workshops in which pitch polishing is done. If, for example, in winter, one neglected one day to warm the workshops, the pitch prepared to

have a suitable mobility at a temperature of about 18° C. (65° F.) would be too hard at a temperature of about 10° (55° F.), and there would be a risk of numerous surfaces being scratched.

### Qualities of a Good Optical Worker

The work of surfacing is a delicate task which demands meticulous care, much attention to method and great cleanliness.

The good workman makes a habit of soiling only his right hand in manipulating the glasses, abrasives, greasy bodies, etc. He always keeps his left hand clean for taking up a gauge, a measuring instrument, any delicate piece, or the handle of a hand lathe.

The surfacing worker needs no special physical aptitude; good eyesight suffices for him, even shortsightedness is not prohibitive.

### Fundamental Principle of Surfacing

The art of making use of abrasives has been set forth in Chapter II; in this chapter will be studied how the efforts and displacements of the glasses or tools must be regulated and combined in order to obtain the desired surfaces rapidly and certainly.

All the rules of surfacing can be summed up in the following. *The work must be conducted in such a fashion that from the moment when all parts of the glass bear on the tool, the wear progresses uniformly over the whole surface of the glass.* This is called the *condition of uniform wear*.

So long as the glass has not the same shape as the tool its projecting parts alone bear on the tool, and it is not essential to follow one routine of working more than another. It is not the same thing when the glass is close to attaining its final form. Let us suppose, for example, that the glass, being too convex or insufficiently concave, is being worked according to a routine which wears the centre more than the edges; a moment can arrive when the correct shape is obtained, but if one carries on the operation a minute too long one will have removed too much material from the centre, and work must be recommenced with another routine.

If, again, one has stopped at the right moment, the surface may be good but the thickness of the glass can be too great; to work the glass to the right thickness without deforming it, it is indispensable to work according to a *routine of even wear*. It is, then, obvious that this routine should be adopted at the outset. With this routine as with the others, the "high" places in relation to the tool continue to be the first to be worn, but one can push on with the work without risk of impairing the surface and without necessitating too frequent verifications.

The optician's art consists, in part, in avoiding the creation of privileged regions on the glass which he is working—that is to say, regions which are not treated as the others are—since the privileged regions

will be either less or more worn than the others. If the tool works really uniformly, it can produce surfaces more perfect than its own, since as its own faults (hills or dales) pass time after time over the same regions of the glass their effects compensate one another.

In order not to create privileged regions one must work methodically. In hand working, particularly, if the inequalities of wear are left to hazard, the results will be uncertain. It is better to work with the machine, since, if it is badly regulated, the surface deformations which it produces are systematic deformations—always the same—and systematic deformations are generally easy to correct by a fresh adjustment.

The problem of uniform wear is linked with that of the manipulation of the abrasive; it is also connected with the problem of the total pressure to be exerted on the tool and with that of the distribution of that pressure over the tool. Finally, it is bound up with the kinematic study of the working of optical surfaces, that is to say, the study of the speeds of rotation and the relative displacements of the glass and the tool. These questions are going to be considered separately.

### **Pressure to be Exerted on a Tool**

If one rubs a piece of hard steel with a file, without bearing on it, one does not cut into the steel. The wear remains nil so long as the pressure on the file is insufficient to make it "bite". From the moment when that limit is passed, the wear increases rapidly in accordance with the increase of pressure and then ceases to increase as soon as the teeth of the file have entered completely into the steel. One sees, then, that the wear is not proportional to the pressure; it is connected with the pressure, but according to a complicated law which depends on the quality of the material attacked, the cut of the file, its number, etc. It is the same in the employment of abrasives, with this difference, that the pressure makes the grains of abrasive penetrate further into the tool than they do into the glass, since the support for the abrasive must always be more malleable than the surface to be worked.

At the commencement of the work the pressure only serves to spread the paste and to equalise its thickness. When the layer is sufficiently thin the pressure must be capable of making the abrasive bite. This minimum pressure should be exceeded a little with the large emeries to make them bite deeply, but should hardly be exceeded at all for fine emeries and for polishing products, which must not penetrate deeply.

It is harmful to exceed and even to attain the upper limit of pressure, that is to say, that for which the grains of abrasive are completely immersed in their support and in the glass. In effect, friction is proportional to the pressure. The work of friction which is not utilised

in wearing the glass is transformed into heat, and it will be seen that heating the glass deforms it.

It is necessary, then, to keep within even narrower limits of pressure as finer abrasive powder is used. For the convenience of argument it may be said that between these narrow limits, the wear is proportional to the pressure, but this is only a rough approximation.

The advantage of hand working over machine working is that it permits distribution of the pressure at the will of the operator, and it is precisely a part of the optician's art to know how to apply the greatest pressure in the region of the glass which must be most worn. For this he makes an effort of pressure with the fist that holds the handle and, if he is working a large piece, he puts his other hand on one side of the work holder. The most striking example of the localisation of pressures is given by trueing with the grinding wheel or by "scouring". These processes of trueing are characterised by the fact that one only grinds one region of the glass at a time, either a diametrical section, a small circular region or an annular zone.

The following is a table of optimum pressures derived from experiment:

*Pressures per square centimetre*

12 to 20 minute emery	..	15 g.* (up to 150 g. for spectacle lens work).				
30 to 60 minute emery	..	10 g.*				
120 to 140 minute emery and polishing on pitch	..	<table style="display: inline-table; vertical-align: middle; border-left: 1px solid black; border-right: 1px solid black; border-collapse: collapse;"> <tbody> <tr> <td style="padding: 0 5px;">6 g.*</td> <td style="padding: 0 5px;">for large tools for large surfaces of high precision..</td> </tr> <tr> <td style="padding: 0 5px;">9 g.</td> <td style="padding: 0 5px;">for small tools for large surfaces of high precision.</td> </tr> </tbody> </table>	6 g.*	for large tools for large surfaces of high precision..	9 g.	for small tools for large surfaces of high precision.
6 g.*	for large tools for large surfaces of high precision..					
9 g.	for small tools for large surfaces of high precision.					
Polishing on paper	..	30 g. (to 45 g.)				
Polishing on cloth	..	50 g. (to 500 g. for spectacle lens making).				
Polishing on waxed cloth	..	25 g.				

In the making of spectacle lenses, where a large output is required without bothering too much about deformations resulting from heating up or flexure, the pressures are pushed as far as possible without scratching. For surfaces less precise than those of astronomical pieces, one adopts pressures a little higher than those indicated by Professor G. Ritchey.

\* According to Professor G. Ritchey.

### Trueing

Trueing plane surfaces on a flat iron tool requires no special technique; it is similar to the trueing of spherical surfaces on concave or convex tools.

### Trueing a Stack of Small Discs ("Carotte")

If a series of small lenses of the same diameter has to be made, they are formed into stacks ("carottes") and given a cylindrical shape of the required diameter in the following fashion.

The moulded or squared glasses are piled up and stuck to one another with opticians' cement (p. 27), warming them slightly. The column thus formed is laid down on a revolving flat tool and pressed against a rule fixed horizontally a few millimetres above the flat tool. The column is made to turn on itself by pushing it against the rule with the fingers. The end of the column which is closest to the edge of the tool, being worn away more quickly than the end which is close to the centre, the column is frequently turned over end to end, without which it would assume a conical shape.

When the stack has lost its roughnesses it is rounded like a tree but not like a cylinder of revolution. To correct this the constitution of the stack is modified as follows. Having traced a pencil line approximately following a generatrix,\* one heats the stack to soften the cement; the little discs are turned in such a way as to distribute the pencil marks on all sides. In this way a new stack is formed which presents little projections here and there. This stack is treated on the plane tool and against the rule as in the first operation until the projections have disappeared.

Work can commence with grit, if the glasses are simply squared. It is continued with finer and finer emeries down to No. 1, if the glasses are to be later edged to a light † (see Chapter VIII), or down to 5 minute emery if no further edging is to be done.

### Trueing by Milling

Spherical tools only give a large output when glasses in "blocks" are concerned. When "blocking" cannot be done the use of toric ‡ tools gives good results in trueing.

To true a concave surface a small toric grinding wheel of emery or corundum, having for its large radius that of the surface to be obtained and for the small radius any suitable radius, is used. This wheel *M*

\* A straight line along the circumference parallel to the axis of the cylinder. (Trans.)

† Edging "to a light" is the system of centring by observing when a reflection of a light source in the revolving lens becomes stationary. (Trans.)

‡ Grinding discs shaped like a motor tyre. (Trans.)

(Fig. 12) revolves at high speed. The lens carrier or "cotret" is a square section rod *A* which slides freely in a sleeve *B* set in fairly slow rotary motion by a pulley *C*; by pressing lightly on the rod *A* the

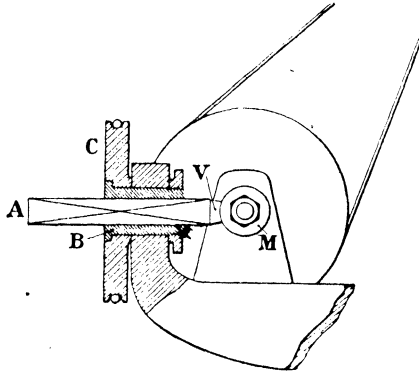

FIG. 12. Truing by milling.

surface of the glass *V* is hollowed out in a few seconds. In this way the surface which would be engendered by rotating the toric about one of its diameters is produced.\*

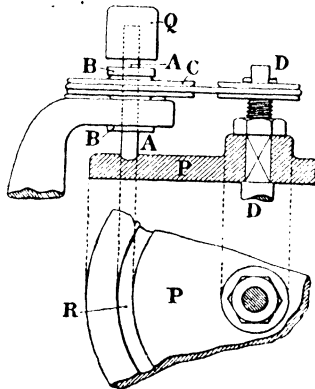

FIG. 13. "Scouring" apparatus.

### Scouring ("Caillebottage")

For truing a convex surface, a plate of cast iron *P* (Fig. 13), known as a scouring plate (*plateau à caillebotter*), carries a circular groove *R*,

\* Improved methods, less sensitive to wear of the grinding wheel, are now in common use; see Twyman, *loc. cit.*, pp. 42-45. (Trans.)



which constitutes the toric tool. The small radius of the groove is equal to the radius of the surface to be trued within the thickness of the emery layer; the large radius can be what you will. The plate is used with grit or with coarse emery. One leaves a "spot", that is to say, in the middle of the glass a small unattacked region is kept, in order not to remove too much material.

The lens carrier is again a square rod  $A$  passing freely through a socket  $B$ , driven by a pulley  $C$  operated by the arbor  $D$  of the plate. The rod  $A$  is normal to the disc and perpendicularly over the groove  $R$ . It is surmounted by a load  $Q$  ensuring a suitable pressure on the tool.

A variable number of lens carrier mountings is distributed around the disc; their number is determined by the condition that the trueing of one glass should be completed in the time required for changing all the other glasses. Thus the operative or workman's time is completely occupied without stopping.

This machine produces the sphere generated by the toric tool.

But one can also "scour" in a concave tool a convex lens of a greater curvature than that of the tool. The use of this procedure allows the number of trueing tools to be reduced. It consists of successively applying all parts of the lens which are to be worn away to the concave tool. If contact with the tool is maintained very much longer in the region near the edges the curvature of the lens is increased. As the curvature of the tool is much accentuated the formation of facets is easily avoided; in scouring on a disc one has more difficulty in avoiding facets.

The same procedure is sometimes used in smoothing and even in polishing, in hand working. To accentuate the curvature of a lens one avoids making its centre bear and extends the pressure towards the edges of the lens while making it bear on the region of the tool which has the greatest speed, involving holding the lens carrier nearly perpendicularly. If, on the other hand, one wishes to make the surface shallower, that is to say, to diminish its curvature, one applies the central part to the edges of the tool, involving presenting the lens very obliquely.

These methods of working, thanks to which a practised artist succeeds in obtaining a perfect spherical surface with a tool of slightly different curvature, are very dangerous when they are practised by inexpert workmen. It would be risky to base precision manufacture on the practice of such procedures of surfacing, which should be reserved for exceptional cases.

### Smoothing and Polishing

All the procedures of normal smoothing and polishing tend to the realisation of the fundamental principle of uniform wear, whether one

works on an automatic lathe, a pedal lathe, a hand lathe or a fixed tool post.

So long as the glass has not arrived at the final smoothing, that is to say, so long as it has not the exact shape required, the hollow parts hardly wear away at all, and it is not very useful if the pressure is equally distributed over the parts which bear. In polishing it is not the same thing; it is important that during this operation the pressure should be uniformly distributed, otherwise the good shape supposed to be obtained by the last smoothing would be altered. To assure a uniform distribution of the pressure it is important that the abrasive should be incorporated in a sort of elastic cushion, since such a cushion sinks naturally in those regions where the pressure tends to be stronger than elsewhere. That is why all the supports of polishing products are elastic; cloth, taffeta, paper, Berzelius, pitch.

The necessity for an even distribution of the pressure is the reason for the employment of thick or webbed tools. If, for instance, one wished to surface a plate of 20 cm. diameter and 1 cm. thickness, a flexure of the thickness of a cigarette paper (0.03 mm.) given to it would be sufficient to cause the edges to cease bearing. It is necessary, in order that one can neglect the flexure produced by the pressure adopted, that the flexure produced by that pressure should be less than the mean size of the grains of the abrasive employed.

Here, in millimetres, are the mean diameters of the large grains of some samples of emeries and polishing powders.

	mm.
Emery No. 1 (fine) .. .. .	0.170
„ 3 minute .. .. .	0.112
„ 5 „ .. .. .	0.068
„ 10 „ .. .. .	0.048
„ 20 „ .. .. .	0.042
„ 30 „ .. .. .	0.038
„ 60 „ .. .. .	0.022
Extra fine polishing rouge (oxide of iron)	0.003 to 0.006
Tripoli for polishing on paper .. ..	0.002 to 0.003

This shows the perfect rigidity the glass must have in order not to assume a deflection equal to the smallest grains of polishing powder; and the value in polishing with low pressures, as one employs finer and finer powder.

Moreover, the less the pressure, the less risk is there of causing scratches.

The polishing of a lens always takes much longer than its smoothing. The duration of polishing is also greater as a higher precision is sought after; this duration is also a function of the size and curvature of the

lens. Here are some indications of the duration of polishing high quality spectacle lenses.

Plane or slightly curved glasses	.. ..	7 to 8 minutes
Deeply curved glasses	.. .. .	20 ..
Deeply curved toric glasses	.. ..	15 to 20 ..

The polishing of objects of high precision can last hours or even days.

### Refining

As one arrives at the end of smoothing, one can, instead of passing from one emery to another of a higher number, content oneself with pursuing the operation with what remains of the emery on the tool, only adding a few drops of water from time to time to keep the tool wet.

The emery wears down in working, penetrates more into the tool, and when it penetrates to more than half its thickness it works like a finer emery. One is said to have "refined" the emery. Thus in refining 40 minute emery, the same result is obtained as in making a final pass with perfectly clean and well-graded 60 minute emery. If one is not perfectly sure of the quality of the 60 minute emery, it is preferable to finish the smoothing by refining 40 minute emery.

Worn tools always remain charged with refined emery, giving them a characteristic brown colour.

The mechanism of refining is revealed when a polished surface is greyed. After some seconds' working, the surface will be uniformly grey. If one pursued the operation without adding emery, the grey would become finer and the grey surface more reflecting; on the other hand, the tool blackens and must be cleaned with vinegar. The grains of emery appear to have become disintegrated, the particles of corundum become liberated from the earths and impurities which envelop them, and which finally constitute the dirt which adheres to the tool and the lenses.

To avoid scratching the glass by increasing the pressure at the commencement of refining, it is prudent to commence the refining on an auxiliary glass or, better, on the counterpart of the smoothing tool if the two tools have been previously trued up with care.

### Fixed Post Working

This is the most fatiguing, the slowest, but the easiest process. On the condition that the glass does not project beyond the tool and that it is pushed with a suitable effort of the wrist to avoid turning off the edge, it is a routine of uniform wear. It is excellent for surfacing plane or slightly curved pieces.

### Working with the Pedal Lathe or Hand Lathe

This is the method of working preferred by practical opticians. These lathes allow them to develop the whole of their virtuosity; the optician feels in his arms, as it were, the effort to be made and how the glass resists. The hand lathe,\* or French lathe, is used less and less since it demands an independence of the two hands which it takes long to acquire. The pedal lathe, which permits the glass (or the tool) to be held in both hands, is preferred. Nevertheless, experienced workers maintain that only the hand lathe allows of instant stopping when too great a resistance is felt.

However, there are in existence pedal lathes fitted with a powerful brake which is operated by lateral pressure of the knee; in comparison with these lathes the hand lathe has no superiority whatever. In spite of this it is not useless to know how to work with a hand lathe, first, because this type of lathe still exists in some old workshops, and also because the workman who is able to execute precision work on this lathe has acquired an excellent control of his right wrist.†

### Automatic Lathe Working

Automatic lathes produce a wear which is distributed in accordance with a law which only depends on their adjustment. The weight of the glass and its support (or that of the tool) and the effort which produces its displacements being applied to a central ball-and-socket joint, tend to distribute the pressure uniformly over the whole surface to be worked. As one is at liberty to give the movements which one wishes to the glass, they must be regulated in such a way as to distribute the work as uniformly as possible over the tool. For this purpose, after having spread a light coating of rouge on the tool, one allows the driving pin of the triangular frame which guides the movement to rest on it, or better, a small wooden point carried by this pin, and the machine is set in motion for a few seconds. Marks will then be seen to be made in the rouge; they should consist of almost equidistant spirals extending to a distance from the edges a little less than, or equal to, the radius of the glass to be worked. When the ratio of the number of oscillations to the number of revolutions of the tool per minute is a simple ratio, such as  $\frac{1}{2}$ ,  $\frac{2}{3}$ ,  $\frac{3}{5}$ , the pin of the triangle repasses the same points on the tool every second, third or fifth turn. This is to be avoided as it would create privileged zones on the tool. The

\* The type of lathe referred to is generally known as a lap-lathe or lapidary's lathe, and has its axis vertical. (Trans.)

† For an account of the motor-driven tool post used in many British workshops, see Twyman, *Prism and Lens Making* (Hilger, 1942).

ratio of the speeds must not be a simple number; it should be, for instance,  $\frac{1}{11}$ , or  $\frac{2}{13}$ . The machine must be regulated accordingly.

Automatic lathes must be employed for surfacing heavy pieces and large blocks, because the force to be used for this work becomes excessive for the workman. On the other hand, the surfacing of small, deeply curved lenses can hardly be done on automatic lathes; these lathes could, in fact, exercise too great or too rough a pressure on the glass.

For medium sized blocks or pieces, the use of automatic lathes is only economical if one operative can control several posts at a time without ceasing to be occupied. For this, the time of operation of surfacing must be greater than the time necessary for fitting up a post with a new lens or a new block of lenses. This condition leads most often to polishing alone being executed on the automatic lathes, smoothing being done by hand on pedal lathes. Thus, in some workshops, pedal lathes alternate with automatic lathes. A workman, while watching over the polishing on automatic lathes, smooths on the pedal lathe the glasses which will later pass to polishing on the automatic lathes.

#### Turning the Edge Over ("Edge-off")

When a lens or a block of lenses on a support which is manipulated by means of a screwed handle (Fig. 14) is pushed over the tool, an effort is exerted,  $E$ , which is not in the prolongation of the frictional

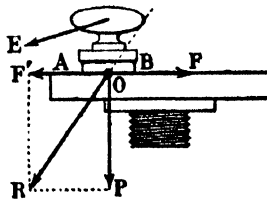

FIG. 14.

resistance  $F$ . From this results a tendency to rocking which augments the pressure towards the edge  $A$ , and lessens it towards the edge  $B$ . As all the points on the lens come first in advance of and then behind the displacement of the lens, they are submitted to alternations of augmentation and diminution of pressure. It seems, then, that it should establish a compensation in such a way that the edges will not be more worn than the rest of the surface. It would be almost so if the wear were proportional to the pressure, since the pressure and the

wear is not proportional to the pressure; if the wear has increased by  $\frac{1}{4}$  at  $A$  it may only have diminished by  $\frac{1}{10}$  at  $B$ , and the mean indicates an excessive wear at the edges. According to this explanation, the workman who exerts the optimum pressure on his lens, *i.e.* that for which the wear is very nearly proportional to the pressure, will turn off the edges less than if he worked with a slightly higher pressure.

In any case, to avoid turning off the edges, rocking force towards the rear must be applied in such a way as to annul the tendency to tilt forward resulting from the forces  $E$  and  $F$ . There is a technique to be acquired of pushing the glass over the tool and increasing its pressure towards the rear a little.

To habituate oneself to combining these two forces properly, working, at least for some time, with ball-and-socket handles (Fig. 15) is

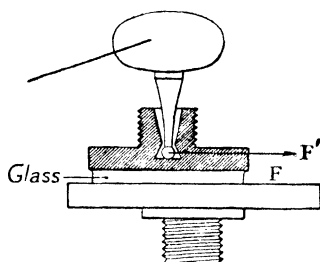

Fig 15. Ball-and-socket handle.

recommended. These handles are employed with socketed tools used for surfacing on automatic machines. The socket being very close to the surface of the plate, the force  $F'$ , which is applied at the ball-and-socket joint, is less distant from the frictional resistance  $F$ . In pushing the disc with a ball-and-socket handle one is obliged to make with the wrist, at the same time, the effort necessary to keep the handle upright. This force is almost equal to that which would prevent the edges turning off if one applied it to a screwed handle.

The automatic machine, which drives the disc by the intermediary of a rigid finger, applies the force  $F'$  direct to the socket, situated much closer to the rubbing surface than was the force  $E$ . That is why a surface worked on an automatic lathe is less turned off than a surface worked by an inexperienced operative using a screwed handle. However, when the block, or the glass, stuck on to the plate is thick, the rubbing surface is further removed from the socket and the cause of turning-off the edges is accentuated.

The aspect of the matter is changed when spherical surfaces are concerned. In this case a central pressure, normal to the surface, is not distributed uniformly over the whole surface. The pressure decreases



zontal dragging force of the driving pin should not produce any increase or decrease of the pressure on the edge at *A* or *B*, it is necessary, and sufficient, for the force of the ball joint (or the hand) to be applied at the point where the frictional forces—which, in the case considered, are directed along *AD* and *BD*—meet.

It would be suitable to place the ball joint at *D* if one had to work a cylindrical block reduced to its straight edges. If the block is not hollowed out the frictional forces at symmetrical points near the middle cut one another near the base of the lens carrier. The frictional forces in the central region cause the point of application of the resultant of the frictions to descend close to the surface of the block. The preponderance of pressure in the central region further increases this effect. The optimum position for the ball joint is, then, at a certain point situated between the point *D* and the surface to be worked. Moreover, this point is closer to the surface as the angular opening is smaller; for an opening of  $120^\circ$ , its distance from the summit of the surface does not amount to  $\frac{1}{5}$  of the radius.

When spherical lenses are concerned instead of cylindrical ones, the distance from the vertex of the surface to the socket must be even smaller. Theoretically, the force of the ball joint should be applied barely above the middle of the block, both for spherical surfaces and for planes, if it is desired to distribute the pressures symmetrically around the axis of the block. But as the pressure is greater at the middle than near to the edges of a curved block one makes up for this difference in pressure by guiding the block by a point situated a little above the point at which the resultants of the frictional forces coincide. Effectively a sort of "scouring" is carried out which, on the whole, is only a systematic "turning down" of the edges. In guiding the glass by a point remote from its vertex one maintains the minimum pressure far from the vertex. This practice is only efficacious on condition that only a fairly light pressure is exercised, that is to say, a total pressure such that by augmenting the local pressure in the region of a zone of the block the wear in that region is sensibly increased. If the total pressure were too great, that is to say, near to its maximum of usefulness, a local increase of pressure would produce no effect.

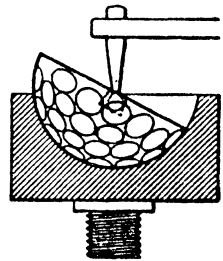

Fig. 17.

The effect of scouring which is concerned is particularly appreciable in the case of a convex block held in the hand and worked in a concave tool. It would be impossible to guide such a block (Fig. 17) on an automatic machine, the force of the ball joint finger would crush the block against the sides of the concave tool without succeeding in

making it oscillate therein. This is why, when working convex blocks on an automatic machine, they are placed underneath with the concave tools on top. Again, the concave tool must be guided by a socket sufficiently close to the base of the tool. Let us suppose that a concave tool is guided on an automatic machine by a socket that is placed too high (Fig. 18). The resultant of friction being at *F* and the force of the machine at *D*, it is conceivable that there is an excessive compression at *A*. This compression can be so strong that in driving the work

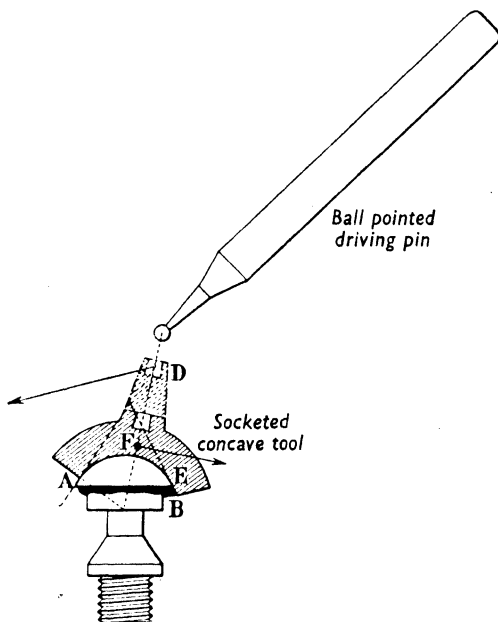

FIG. 18.

quickly enough to soften the mallet pitch slightly, the pitch would be packed up towards the top and the block would cease to be spherical.

If the concave lenses were blocked in the same concave tool, to be polished on a pitch polisher, a deformation of the polisher would be found; the pitch would be packed towards the top and the block would automatically form, by scouring, a more strongly curved polisher in such a way that the surfaces obtained would be too concave.

Thus, strongly curved lenses may be guided by a point slightly further from the centre of curvature than in the case of less curved lenses, but in any case it is necessary to hold the lens carrier (or the tool) at a point fairly close to the surface to be worked.

In hand working, one places small convex lenses on top, since if they are placed underneath the middle of the surface is not worn, because the tool held in the hand does not turn. It is none the less true, that it is more difficult not to turn down the edges of a convex lens when it is worked above, than it is not to turn down the edges of a concave lens.

This difficulty can be avoided by working the convex lens with a concave tool guided by a ball-pointed handle (Fig. 15), by a ball-pointed pin (Fig. 18), or by a loose handle. As the concave tool then turns by being dragged, as on an automatic machine, the centre of a lens fixed to a support screwed on to the arbor of the lathe can be ground.

These handles and pins are, however, inconvenient; with them the worker does not feel whether the tool works at its centre or at its periphery.

### Chocks

The turning over of the edge (edge-off effect) is often localised in an annular zone of a few millimetres touching the edges.

If the turning over seems to extend further there is, in addition, a defect of routine causing the wear to increase according to the increase in distance from the centre of the surface.

To free oneself from the edge-off effect, the piece to be surfaced is surrounded with blocks (or chocks) of glass in order that the turning over may localise itself on these chocks, which are removed once the surface is finished. It is as well for the chocks to be of the same material as the lens; otherwise the wear might not progress equally on the piece and on the chocks. Nevertheless if one works with overlap, it is better to employ chocks of softer material since they are not ground continuously.

### Overlapping

When the block overlaps by one-half of its radius, for example, the circle of half the radius is always in contact with the abrasive and the ring which surrounds it is only partially in contact with the tool. On this account the wear is greater at the middle. On the other hand, the speed of rotation of the block, which is equal to that of the tool when there is no overlap, becomes slower and slower as the overlap increases.

In position 1 of Fig. 19 the speed of rotation of the glass is equal to that of the tool on condition that the adhesion is the same at all points (well-kneaded abrasive suitably wet all over).

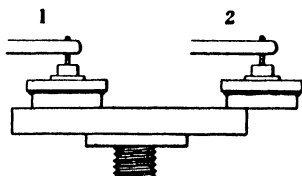

FIG. 19.

In position 2 the speed of the lens would be small and in a contrary direction to that of the tool (case of tangent wheels).

Between positions 1 and 2 there is a position where the rotation of the lens ceases; this is never attained in practice. But whenever there is overlap, the rotation is slowed down. Fig. 20 indicates the percentage losses of speed of one disc dragged by another, in the case of two equal discs (curve *A*) and in the case of two discs, one of 220 mm. diameter and the other of 255 mm., the larger being placed on the smaller in curve *B* and inversely in curve *C*. These curves have been established experimentally. The abscissæ are the eccentricities, expressed in fractions of the radius of the small disc.

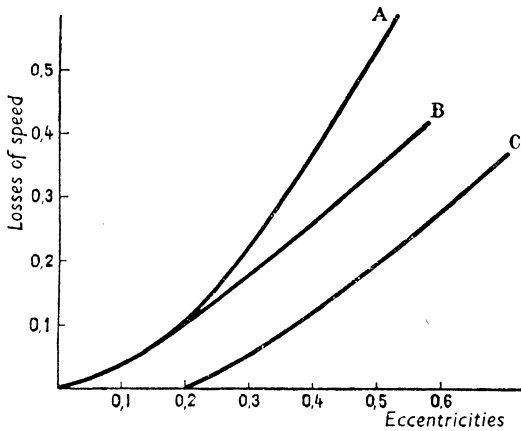

FIG. 20.

These curves represent the losses of speed of rotation through the effect of overlap on one disc dragged by another in three frequently encountered cases. In making these measurements great care was taken to keep up a uniform wetness of a thin layer of 40 minute emery. This uniformity of humidity was ascertained from the constancy of the speed of induced \* rotation. In these conditions the losses of speed depend on the eccentricity and on the out of plumbness which can result from it.

If the worker does not maintain the humidity of the abrasive paste very carefully by throwing some drops of water on to the zone of the lower disc from time to time, the paste dries unevenly. The central region, which is never uncovered, remains wet while the zone which is periodically uncovered at each revolution dries fairly quickly. The

\* Induced rotation is rotation given to a free tool by the drag of the tool on the lathe spindle. (Trans.)

abrasive paste bites more in proportion as it dries; the action of the zone becomes preponderant and principally governs the dragging round of the disc *S*, in the manner of gearing. Insufficient watering of the zone can increase the speed of rotation of the disc *S* by about 20 per cent.

Thus, an upper disc *S*, overlapping considerably, which loses 30 per cent of speed when the abrasive paste is very homogeneous, can, on the contrary, for the same overlap, turn more quickly than the dragging disc *I*.

An uneven carriage (or tilt of the disc) acts in the same way as drying. A flexible plate which rests out of plumb on a table curves itself, and only rests by one extremity and by the region that touches the edge of the table and supports the major part of the weight. The disc *S*, or the overlapping glass, does not flex to any apparent extent, but it nevertheless assumes a deflection of the order of a micron, that is to say, of the order of size of the grains of abrasive. It bears, then, mainly on the abrasive grains near the edge, and it is still the zone which governs the dragging more than the central region.

The following experiment demonstrates the effect of being out of plumb. A disc *S* being held overlapping, a pressure is exercised through a roller on the overlapping part; the rotation of the roller can only brake the induced revolution a little. It is observed that the induced revolution accelerates considerably as the pressure of the roller is increased. The effect of the wear produced by the out-of-plumbness does not solely result from the variation of the speed of rotation and from the excess of pressure of a part of the circumference; it also depends on the greater or less extent to which the abrasive grains protrude. If, under the well-centred pressure of the disc *S*, the grains are very slightly embedded in the discs, an excess of pressure at one edge will make the abrasive bite more on this side. If, on the contrary, the grains of abrasive are already well driven in under medium pressure, an excess of pressure will not make them bite much more. The optimum mean pressure depends on the size of the abrasive grains (see p. 53 for table of optimum pressures).

As has been seen above, the slowing of the relative rotation has the effect of accelerating the wear on the regions of the block nearest to the periphery. This effect of slowing compensates, then, to a certain extent for the alternation of wear of the annular zone. On the other hand, the effect of out-of-plumbness pointed out in connection with work on a fixed tool post accelerates the wear at the centre of the block, if it is placed on top, in such a way that it produces a compensation between the effect of tilt and that of overlapping. For these various reasons there is, practically, no grave drawback in overlapping by  $\frac{1}{4}$ ,  $\frac{1}{3}$  or even  $\frac{1}{2}$  the radius of the block, on automatic machines, if one does not seek

to produce surfaces of high precision. The optimum overlap depends on the weight of the block; if it is very heavy it must overlap a little less than if it were light. It should not overlap as far if the rotation of the block were braked, since if the glass overlaps its rotation is slowed down and is as if it were momentarily braked; that is a reason for not overlapping too much. According to Dr. Otto Mackensen, if the radius of a plane glass guided by a central ball joint is eight-tenths of that of the tool, an overlap of 0.1 of the radius of the glass produces a sensibly uniform wear simultaneously on the glass and on the tool.

Another consideration intervenes in the regulation of the overlap. The abrasive paste must be well mixed to be equally biting throughout, otherwise the observance of a routine of equal wear would be illusory. To renew the abrasive or to moisten it in the region which is never uncovered, the machine must be stopped and the glass removed from the tool. In order to render this action less frequent, a small circular or crossed groove is frequently cut in the region of the polisher which is never uncovered, in which collects a reserve of wet abrasive which automatically feeds the neighbouring zones.\*

Here, from the point of view of mixture of the abrasive paste, are the optimum overlaps. Let  $R$  be the radius of the tool and  $r$  that of the block.

$$\begin{array}{l} \text{For } \frac{R}{r} = 1 \text{ (case of truing up the two discs),} \\ \text{optimum value of overlap } \leq \frac{r}{2}, \\ \\ \frac{R}{r} = \frac{4}{3} \quad \dots \quad \dots \quad \dots \quad \leq \frac{r}{3}, \\ \frac{R}{r} = \frac{3}{2} \quad \dots \quad \dots \quad \dots \quad \leq \frac{r}{4}, \\ \frac{R}{r} = 2 \quad \dots \quad \dots \quad \dots \quad = 0. \end{array}$$

Thus it is possible to choose an adjustment of the machine which will give a satisfactory routine for the block, *i.e.* one of nearly uniform wear. Nevertheless, every routine with overlap (on ordinary machines) is imperfect, for the central part, which never overlaps the tool, is treated like a small lens worked on a large tool, but whose rotation has been braked, and, as has been seen, such a lens becomes convex. The theoretical profile of a lens which has been worked with overlap

\* In English practice it is usual to cover the whole surface of a polisher with grooves and to superimpose a pattern of smaller honeycomb grooves on the bearing surface. (Trans.)

is, then, a sinuous profile (Fig. 21) raised in the middle, so long as one does not work on a fixed tool post, *i.e.* without rotation.

In the preceding, a glass or a disc rested on a larger plate, which is the most frequent case, has been considered. But it may happen that one is obliged to place the piece to be worked underneath and to work it with a larger tool. This occurs, for instance, when one has to surface a block of prisms. The block is so thick that if it were placed on the tool the overturning couple which produces the "edge-off" condition would be considerable. A large tool guided by a ball joint over a small glass overlaps continuously. Its speed of rotation is then a little smaller than that of the lathe; it can only be equal to that of the lathe at the

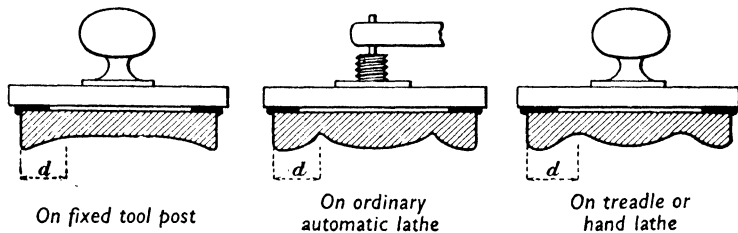

FIG. 21. Effects of overlap  $d$ .

fleeting instant when the axis of the tool just coincides with that of the lathe. Now, one avoids that coincidence, during which the work of grinding by rotation is nil. This inequality of speeds of rotation results in a slighter wear of the regions of the block of glasses which are only rubbed by the central zone of the tool; in a word, this routine tends to make the block slightly convex.

If the wear of the glass worked on the tool can be almost uniform, the wear on the tool is less so. It is useful to keep account of the wear of the tool, for if one can choose between different working routines, that which deforms the tool least quickly must be preferred. On the other hand, as one is obliged in certain cases to mount the glass on the lathe to work it with the tool on top of it, that which is to follow will apply to these two cases.

### Wear of a Large Glass on a Large Tool ground by a Smaller Tool

In a general way, the wear is the result of work of translation and work of relative rotation of the tool with respect to the glass. These two kinds of work do not add together algebraically but geometrically, that is to say, by paying attention to the direction of translation and the direction of rotation at each point. Without trying to add them up geometrically, which would be complicated, it is useful to examine the work of translation and of rotation separately.

The *work of translation* is the only kind which is produced on a fixed tool post. If the same tool passes equally all over with the same pressure, it produces a uniform wear. But in order for the tool to pass over the edges, exactly as elsewhere, it must overlap and if it overlaps, it itself deforms. Yet it has no need to overlap much since, in proportion as it overlaps, it wears to a greater extent, because its weight is distributed over a smaller surface.

The *work of rotation* is different according to whether the tool, placed above, turns freely (automatic machine) or if it is braked or held in the hand. Both cases must be examined.

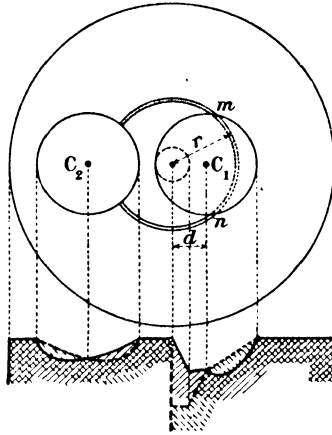

FIG. 22.

Let us suppose the glass mounted on the lathe and worked with a smaller tool placed on top of it.

Let us consider the wear of a narrow ring of radius  $r$ , which is supposed to be traced on the glass (Fig. 22).

Let us suppose the centre of the tool immobilised at a distance  $d$  from the centre of the glass.

Let us study the mean wear of the narrow ring in the case when the tool is prevented from turning about its axis, when the lathe is working, and in the case when the tool is at liberty to turn about a central ball-and-socket joint.

When the tool does not turn, the wear of the arc  $mn$  on the tool is proportional to  $r$ . When the tool turns, the wear is the same at all points on the tool, as at its centre. In this case, then, the wear of the arc is proportional to  $d$ . If the wear on the arc  $mn$  of the tool in the first case is known, it is sufficient to multiply by  $d/r$  to obtain the wear in the second case.

As for the mean wear of the ring of radius  $r$  on the glass, it is evidently proportional to the ratio  $\frac{mn}{2\pi r}$  and to the wear of the arc  $mn$  on the tool. As a result, the mean wear of the ring on the glass and the wear of the arc  $mn$  on the tool are proportional to  $d$  or to  $r$  according to whether the tool turns freely or does not turn.

Thus, having determined the curve of wear along a radius of the glass and supposing that the tool is prevented from turning, the curve of wear in the case when the tool turns freely is easily deduced from it. The corresponding ordinates of the two curves are in the ratio  $d/r$ .

From this, it is easy to construct the profiles of the grooves cut by the tool according to its position and according to whether it does or does not turn. The traces of Figs. 22, 23 and 24 have been established by supposing the small tool to be supple enough (a cloth polisher, for example) to conform to the deformations of the large tool. A slide rest lathe tool having precisely one of the profiles thus determined would produce the same wear as the disc at the place considered.

Fig. 22 shows the same small tool immobilised at  $C$ , and then at  $C_2$  and the half-profiles of the grooves which it cuts in the lower tool according to whether it does not turn (full line) or does turn (dotted line). The depths of the grooves are enormously magnified. Obviously complete profiles are symmetrical.

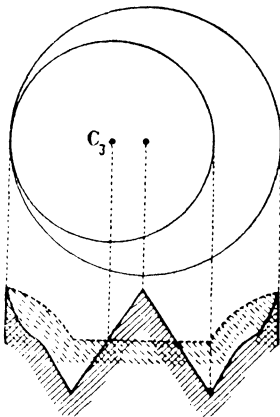

FIG. 23.

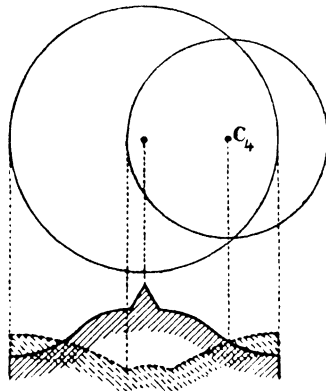

FIG. 24.

Fig. 23 shows the profile cut by a larger tool  $C_3$  in the same conditions of position and of circumstances as for Fig. 22.

Fig. 24 shows the grooves made by the same tool placed at  $C_4$  and overlapping. Certainly, in practice, the above profiles are smoothed out by the addition of the wear produced by the displacements of the

small tool on the large one. On machines whose movements alternate on the arc of a circle this smoothing out is nearly satisfactory at the middle of the motion only; in effect, the tool remains longer at the places where the translation changes direction.

Comparison of these very different profiles is very instructive; here are some of the deductions which can be drawn from them.

(1) It would be almost chimeric to try to make a plate flat on a mechanic's lathe with tools varying so constantly in profile. The effect of rotation is, then, fatal when the piece to be surfaced is larger than the tool.

That is why the surfacing of telescope lenses is executed by translatory working, the extremely slow rotation only producing negligible work. The rotation then only serves to change the regions in contact, little by little, just as the worker on a fixed tool post turns the handle of the tool in his hand a little at each pass.\*

(2) The tool when turning freely cuts a groove which is deeper on the side nearest to the centre.

(3) The stationary tool cuts a groove which is deeper on the outside. If it covers the middle of the flat tool it produces a central cusp.

Although the groove that it cuts is generally shallower than in the case of the free tool the quantity of material worn away is greater, because the diameter of the bottom of the groove is greater. The excess of material worn away is the result of the work done by the force which must be applied to the tool to keep it from turning.

(4) The piece to be surfaced must always be smaller than the tool when the rotation is not very slow.

(5) When a surface worked on an automatic lathe presents a central cavity, the surface can be levelled by braking the tool.

(6) When glasses or blocks are worked on larger tools, these tools deform considerably. There is no way of avoiding this drawback completely by a judicious adjustment of the movements of translation. These large tools must be trued up frequently.

If one wishes to avoid retouching the tools too often, they must be made hardly any larger than the blocks or glasses to be worked. Thus, the tools for surfacing toric lenses singly must not have a diameter very much greater than that of the largest spectacle lenses.

(7) When working by hand on a pedal lathe (or hand lathe) it is useful to cut a hollow at the centre of the tool to avoid the formation of the central cusp.

\* It is more closely analogous to his continual slow progress around the post. (Trans.)

## THE WORKING OF PLANE SURFACES

### (1) On a Fixed Tool Post. Trueing up three Plane Tools

Work on a fixed tool post is particularly recommended for trueing up two light tools. When the weight of the tools to be trued up is small in relation to the pressure which must be exerted to work them (the two tools being of the same diameter), the wear is distributed over them in the same way, on account of symmetry. The central part of the tools which is always rubbed, wears away more than the annular part which overlaps, in such a way that the two tools tend to bear more at the edges than at the centre. On rubbing a third plate with one of the two first, one finds oneself in possession of two concave plates and one convex (or vice versa); then by rubbing the two concave tools together their concavity is diminished. By pursuing the rubbing of the plates two and two, one will eventually obtain three plane plates.

In the case of heavy tools the effect of out-of-plumbness constantly intervenes, because there is always some overlap. It can readily be understood that the pressure is greater at the edges of the lower tool and in the centre of the upper tool. Hence the lower tool tends to become too convex and the upper too concave. The work must be conducted in such a way as to rub all parts of the tool successively and methodically; the orientation of the glass must constantly be varied a little in order that all its parts may be treated, on an average, in the same fashion.

A very slow rotation of the tool does not modify to any appreciable extent the phenomena indicated above; it has the advantage of aiding the uniformity of wear of the tool.

### (2) On an Automatic Lathe

If the glass does not overlap the tool and turns freely about its axis, the system of equal wear is realised for the glass, but it is not generally so for the tool. Since the surfacing of a glass or of a small block on a much larger tool can be done without overlap, the automatic lathe gives a system of equal wear with no other condition but that there is no overlap. On the other hand, if the socket of the lens carrier is very deeply recessed the "edge off" effect is but little marked. This is a particularly simple case of surfacing. If one brakes the glass with the hand, or otherwise, to prevent its turning about its axis or to slow up its rotation, the wear far from the centre of the glass is accelerated; thus one departs from the system of equal wear and the surface obtained becomes slightly convex. It will be the same if, by some means, the rotation of the glass can be accelerated; it will wear

more towards the edges. There is no way of wearing the centre more than the edges without overlapping.

Overlap is essential when one wishes to obtain large output. It is not economical to employ a large lathe to surface a small block. Occasionally blocks are made which are nearly as large as the tool. It must be remembered that, if the glass does not overlap, all regions wear to the same extent as the centre. When the block is centred on the tool the wear is nil all over, since there is no friction, the glass and the tool turning together as if glued to one another. When the block is decentred the wear at its centre is proportional to its distance from the axis of the tool, so that every block wears more as it is removed further from the axis of the tool. Thus, to have rapid wear, passing the centre of the block over the centre of the tool must be avoided, and it is as well to keep the two centres always separated. This condition leads to overlapping.

### (3) On a Pedal Lathe or Hand Lathe

In this case, the rotation of the glass being always braked by the workman's hand, there is a greater increase of wear away from the centre of the glass. As in the case of the fixed tool post, there must be considerable correction of "edge off" by the wrist. To compensate for these drawbacks one has the resource of constantly varying the overlap and of exaggerating it at times, more than is possible on the automatic lathe. Without this the central convexity would be more marked than on the automatic machine. These faults are further accentuated at high speeds.

The same method of working on a fixed tool post gives no central bulge; the central region will be the best.

The workman must acquire a manipulative technique to compensate simultaneously by an effort of the wrist, the out-of-plumbness and the couple which produces the "edge-off" condition.

## THE WORKING OF SPHERICAL SURFACES

### (1) On a Fixed Tool Post

To-and-fro movement of the glass on the tool, as occurs in the case of plane surfaces, is absent. There can only be rotations about the centre of the tool. It follows that there is no system of equal wear. This will be immediately understood on considering two hemispheres. Every sliding movement of the glass on the tool is a rotation around a diameter of the tool. The points of the glass which are near this diameter hardly move at all, and the pressure exerted on the glass carrier does not affect this region; the wear is nil near this diameter and a maximum in the diametral plane perpendicular to that diameter.

By turning the glass about its axis at each to-and-fro motion, one distributes the wear on each concentric annular zone of the glass, but, from one zone to the next, the wear increases as it approaches the centre.

Fixed tool post working is not, then, advisable for spherical surfaces of rather large angular aperture.

## (2) On an Automatic Lathe

The glass being at liberty to turn around a central ball joint, the wear is distributed in the same fashion over the glass whatever may be the angle of inclination of the axis of the glass; the centre always wears a little more than the rest of the surface. There is no system of equal wear. In order to increase the wear at the periphery it is necessary to brake the speed of rotation of the glass; this braking may be done with the hand.

Overlap, which must occur with large blocks, has the effect of braking the rotation of the block (and in consequence of improving the medial region which does not overlap), but the annular region is less worn. Hence, if very good surfaces are required, they must be surrounded by blocks or by other discarded glasses, and must overlap. The central glasses will be better surfaced than if they had been worked without blocks and without overlap.

When the blocks are large and of large aperture—for example, blocks of concave lenses that it is desired to make economically in large batches and which have a radius of the order of 100 to 150 mm.—they must be surfaced by machine on tools which are almost hemispheres. These blocks, which can have an aperture of more than  $130^\circ$ , wear in a very uneven manner, because there is no system of equal wear for spherical surfaces. The difficulty is overcome in the following manner. In smoothing, the wear being stronger towards the centre than near the edges, the concave surface tends to take a mean curvature deeper than the nominal curvature of the tools; on the contrary a convex surface would tend to take a shallower curvature. One selects then, for smoothing concave lenses, a convex tool very slightly less curved than the surface to be obtained on the lens. During polishing the block of lenses and the polisher are moulded to some extent by rubbing them one on the other. The blocking cement and the pitch of the polisher are kept, during working, at a slightly warm temperature which gives them a certain malleability. Thanks to this artifice the pressure equalises itself sensibly throughout, in spite of the unequal wear, in such a way that polishing proceeds almost equally quickly over the whole surface of the block. If it should not be so, the polisher must be judiciously cut away at the places where the polishing proceeds too quickly.

## OPTICAL WORKSHOP PRINCIPLES

### (3) On a Pedal or Hand Lathe -

Since the glass is held by a screwed handle, which prevents it from turning, the distribution of the wear is different. If the lens is held on the axis of the tool it is not worn away at all at its centre, and the wear increases from the centre to the edge. The same glass, if it were held wholly on the side of a hemispherical convex tool, would wear more in the centre than at the edge because the middle would be constantly rubbed by a large circle of the tool while the periphery was rubbed by a small circle. It is conceivable then that between the two positions envisaged above (axis of the lens carrier vertical or horizontal) there would be an intermediate position for which the wear would be almost equally distributed between the periphery and the central region. If the inclination of the axis of the lens holder to the vertical is called  $\alpha$ , the value of  $\alpha$  which gives equal wear at the edges and in the middle depends on the angular aperture  $2\beta$  of the glass. Instead of measuring the angular aperture it is more convenient to measure the sag  $f$  of the glass and divide it by the radius  $r$  of the tool. These are the optimum values of  $\alpha$ .

$f/r$	$\beta$	$\alpha$
0.05	$18^\circ 10'$	$28^\circ$
0.06	$20^\circ$	$26^\circ 50'$
0.1	$26^\circ$	$26^\circ 50'$
0.15	$31^\circ 50'$	$28^\circ 35'$
0.20	$37^\circ$	$29^\circ 40'$
0.25	$41^\circ 25'$	$30^\circ$
0.30	$45^\circ 30'$	$29^\circ 40'$
0.40	$53^\circ$	$28^\circ$
0.50	$60^\circ$	$24^\circ 50'$
0.60	$66^\circ 25'$	$20^\circ 50'$

It can be seen from this table that one can produce on a concave tool, or a concave lens, three concentric rings worn exactly as much as the centre. It suffices for this to choose a convenient value of  $\alpha$ ; thus for  $\alpha = 28^\circ$ , the rings whose semi-apertures  $\beta$  are  $18^\circ 10'$ ,  $27^\circ 30'$  and  $53^\circ$  are worn to the same extent as the centre.

On the other hand, calculation shows that if instead of the angle  $\alpha = 30^\circ$  the angle  $\alpha = 32^\circ$  is employed, the excess of wear at the centre over the wear at the ring defined by  $f/r = 0.25$  is only 5 per cent. An oscillation of some degrees one side or the other of the optimum inclination is, then, quite admissible; moreover, it is quite sufficient for avoiding the streaks which one would observe if the polisher were immobile.

In hand working, small oscillations must be made around the optimum value of  $\alpha$ . If the axis is held too vertically the wear is greater at the periphery; if it is held too inclined the wear is accentuated at the centre. It is, therefore, useful to place at the worker's side, as a template, a rod of some sort indicating the value of  $\alpha$  which he ought to observe. This rod is placed at the inclination, read from the above table, related to the value  $f/r$  for the lens to be surfaced.

It is to be remarked that if the worker makes a lens oscillate rapidly enough the work of wear resulting from this oscillation makes the wear prevail at the centre. In this case the value of the angle  $\alpha$  must be reduced a little. If a block of large angular aperture is concerned, one is hampered by too large a value of the angle  $\alpha$ . In this case, in order to permit a reduction of the angle  $\alpha$ , the lathe must be rotated fairly slowly and the oscillation must be fairly quick. When polishing is concerned, the polisher can still be cut away a little on a circular ring passing through the centre of the lens, that is to say, subtending the angle  $2\alpha$ .

According to all that precedes, the inferiority of treadle lathes or hand lathes in relation to automatic lathes is shown by the following points.

It is difficult to surface a convex lens mounted on one of these lathes, for its summit is not worn by the effect of the rotation unless the tool is guided by a ball-and-socket handle, by a ball-and-socket pin or by a loose handle. If the glass is placed on top of the tool there is great difficulty in avoiding turning down the edges since the point by which it must be held to annul the turning down couple would be below the glass. To obviate this difficulty, convex lenses of moderate curvature are worked in concave tools of a radius slightly greater than the radius to be produced. By a technique analogous to "scouring" (caille-bottage) one arranges for the glass to bear successively on its summit and on its other regions.

Treadle lathes, on the contrary, show their superiority by the following points.

By observing the law of optimum mean inclination one realises a better routine for surfacing small lenses than it is possible to realise on an automatic machine without braking.

The overlap can be varied from one oscillation to the following one in such a way as to smooth out the demarcation which there would be on an automatic machine between the zone of overlap and the central zone.

#### (4) On a Lathe with Adjustable Relative Rotations \*

This type of lathe, which permits separate adjustment of the speeds of rotation of the concave and convex tools, combines the advantages of ordinary automatic lathes and hand lathes. By giving the concave tool a very slow rotation in relation to the rotation of the lathe, the block carried by the concave tool, however heavy it may be, behaves like a small block worked on a treadle lathe; its own rotation is negligible. Thus on these machines, adjusted in this way, large, very open blocks can be worked by making small oscillations around an axis inclined at the optimum angle given for each case by the preceding table. In this way a system will be realised which assures an equal wear of the centre of the glass and of three concentric rings; the wear of the intermediate rings not being able to differ sensibly from the wear of the rest of the surface.

Other adjustments of these lathes are studied in Chapter V on pp. 158 and those following.

#### Surfacing Small Faces of Deep Curvature

In this case it is impossible to form blocks and each lens must be mounted on a mallet stick on the axis of the lathe. If the glass is concave it is always placed on top of the convex tool; if it is convex it is mounted on the lathe and placed, in consequence, under the tool. Obviously one must endeavour to obtain a spherical surface, but it is absolutely necessary to realise a surface of revolution. For this it is essential that the worker holds his mallet stick in such a way that the effort of his hand passes exactly through the middle of the glass (or of the tool). That is the great difficulty, for the glass, or the tool, has very little base. The transverse components of the pressures of the hand tend to give an egg-shape to the convex piece and a basin shape to the concave counterpart.

Let us consider, first, the case of a concave surface mounted on an ordinary mallet stick. As the point of the glass which is located on the axis of the convex tool is not worn, the worker must guide his mallet stick in such a way that all regions of his lens pass successively over the axis of the tool. Rapid displacements are not useful. The worker, then, will often change the position of the mallet stick between his fingers to make it turn and he will impress an oscillating movement around the optimum obliquity passing through the centre of curvature (see p. 76). The ball-and-socket or pointed mallet stick can be suitable for workers who have not yet acquired a "good hand" for this kind of surfacing, since it dispenses with the observation of the opti-

\* Several specimens of such lathes are in service at the Institut d'Optique, Paris. See p. 158.

imum inclination and allows the glass to revolve with a regular movement proper for the production of a surface of revolution.

A convex surface that has been placed on the axis of the lathe has every chance of being a surface of revolution. Its centre is not worn by the effect of rotation of the lathe but only by the movement of the concave tool. In this case a high speed for the lathe is not indicated, but a rapid oscillatory motion must be imparted to the tool holder. The use of a ball-and-socket pin is more to be recommended than in the case of concave lenses for it permits a more rapid movement to be usefully given to the lathe, since the concave tool then participates in this rotation.

Another practice can be recommended; it is borrowed from lapidaries \* (see p. 251) who have to hollow little cups in corundum or ruby. The convex tool (or convex lens) is fixed at the extremity of a rod some centimetres long mounted with a cardan joint on the axis of the lathe, in such a way that it can be inclined in all directions to about  $20^\circ$  from the axis of the lathe. With such an apparatus the worker cannot do otherwise than direct the force of his hand along the axis of the rod mounted cardan-fashion on the lathe. As it is impossible for him to deform the surface by an unconscious scouring movement ("caillebottage") he has a good chance of obtaining a spherical surface at the outset.

Concave surfaces obtained by this procedure are also surfaces of revolution, always on condition that they are made to turn on their axis very regularly. To accomplish this it would be as well to provide lens carriers having a steel axis long enough to turn very freely in a central hole in the mallet stick (or driving pin).

Since the pressure is always at a maximum in the part of the glass through which the axis of the cardan rod passes, the region of maximum pressure on the glass is conveniently caused to vary regularly by impressing, for instance, a spiral movement on the mallet stick or by varying the amplitude of the swing of the hand.

The employment of the cardan rod permits a concave glass to be blocked on that rod without inconvenience, and to work it with a convex tool held by a driving pin. The glass cannot take, thus, any but a shape of revolution very close to a sphere. Only the convex tool can wear in an asymmetric fashion unless it is mounted on a little axis turning freely in a hollow driving pin.

### **Correction of Spherical Tools by Rubbing them Together**

This operation does not provide the same precision as in trueing up flat tools as one can only rub together two tools instead of three. To remedy the inconvenience of out-of-plumbness, if the tools are a

\* Gem-stone cutters.

little heavy, it is well to employ tools of unequal angular aperture, for instance, by working a concave tool on a half-ball or a convex tool on a concave tool of large angular opening. Thus the out-of-plumbness can be suppressed or diminished and work done at the optimum inclination. The correction of curvature can be obtained by varying the mean inclination of working to the lathe (if one holds the glass by a screwed handle).

In correcting pairs of tools of the same diameter but of small curvature the drawback of out-of-plumbness can be compensated by successively working the concave on the convex tool and then the convex on the concave.

Tools are generally rubbed up with 10 minute emery.

If the tools have just been turned or have never been used, the emery does not bite everywhere. Only the parts which bear take on a brown tinge. The operation is judged to be completed when the brown tinge extends uniformly over the whole of the surfaces of the concave and convex tools.

In the case of tools believed to have been deformed by wear, the parts which bear on one another can be seen by commencing rubbing up with polishing rouge. More often one is content to rub up with 20 minute emery. The parts which bear take on a deeper tinge. If the tools are judged to be but little deformed, the rubbing up is completed with 20 minute emery; if not, one reverts to 10 minute emery and then to 20 minute emery.

### **Retouching Surfaces by cutting away the Polishers**

When one tries to obtain a rather large surface of precision (more than 10 cm. diameter), it is rarely that it is obtained at the first attempt; either one has overlapped too much, or the speeds and pressures, a little too high, have produced thermal deformations or flexures, or the tools leave too much to be desired. One could try to correct, by a modification of the working routine, the systematic causes of defects, and even succeed in it, but it is not always possible and it is often more certain and more rapid to keep to the same working routine (the same speeds, the same track, the same pressure) and to cut away the polisher in judiciously chosen regions by digging out more or less numerous streaks to diminish the useful surface.

If a larger surface, hand worked by a smaller tool, is to be retouched, that surface may not be a surface of revolution, and the defects may be disposed non-symmetrically. The high points of the faults having been carefully located, they must be corrected by local retouching. The use for this of tools smaller than the defects seems to be essential, but rather than change the polisher, it is convenient to cut away at the edges the polisher with which the surface has already been worked in

such a way as not to make it work on its zone. One must always be wary that the weight of the tool distributed over the smaller surface is not excessive. The zone cut away must not, then, be very large. In place of completely suppressing the zone of the polisher, it is preferable to cut it away progressively, by cutting it in streaks in such a way that the streaks come closer and closer together towards the edge. The effect of the work of retouching thus becomes smoothed out automatically, without one's having to be preoccupied to obtain this result by systematically varying the amplitude of the oscillations of the tool.

If the surface to be retouched has been obtained on an automatic lathe it can only be a surface of revolution, which simplifies the problem. In that case one can work as follows.

The surface to be retouched is carefully examined with the proof plate (see Chapter VI) and the limits of the hollow regions are marked (for example, the central region over a radius of 2 cm. or a zone for 3 cm. from the edge). One places the glass on the tool at one of the extreme positions of the track and marks on the tool the parts which bear on the depressed regions. The glass is pushed to the other extreme position of the track while noting the zones of the tool traversed by the depressed regions of the glass. If one digs out the polisher completely in the regions thus located and proceeds with the polishing, it is clear that the depressed parts of the glass, no longer touching the polisher, will no longer be worn away; only the higher spots of the glass will still be worn, but the limits of this wear will not be smoothed out. Hence the polisher must not be hollowed out completely but reduced gradually in such a way that the reduction is very small near the limits of the zone to be reduced.

It is more difficult to apply this procedure when a hollow zone situated at a certain distance from the edge is to be obliterated. In this case, when the glass is almost central on the tool, the work of wearing away due to the rotation is almost nil (if the work is done on an automatic machine). When the glass is eccentric, a part of the hollow zone is worn by the part of the tool nearest the edge and the opposed part is worn by the central region of the tool. Thus almost all the surface of the tool contributes to the wear of the hollowed zone. Since cutting away the whole polisher is inconceivable, one contents oneself with cutting away an annular zone of the tool, on which about  $\frac{1}{4}$  or  $\frac{1}{3}$  of the hollowed zone rubs when the glass is on the most de-centred part of its course, for that annular zone is longer in contact with the hollow zone than is the central region.

In the case of a pitch polisher, one waits until it is well cooled down and then, with the point of a knife, strokes or hatchings, more or less spaced apart, are cut, as when making shadows with a pen in a draw-

ing. The general surface of the polisher is unaltered, it is only cut with numerous furrows. If the pitch remains fairly malleable, as it must for polishing large, deeply curved blocks, the furrows fill up through the edges collapsing and they must be remade several times.

If, in order to collect a reserve there of wet abrasive, a channel has been cut in the central zone (which is never uncovered as is stated on p. 68), this constitutes a kind of reduction of the central zone of the polisher, and it may be as well to reduce the zone a little or to cut a channel there also in order to re-establish equilibrium of wear.

When paper polishers are concerned, little sectors or strips almost regularly spaced are removed with a knife.

For working on a cut-away polisher it is expedient to increase slightly the pressure per unit of bearing surface. If, in fact, one worked with the mean pressure—for which the wear is nearly proportional to the pressure—the reduced parts supporting, per unit of surface, a load greater than the unreduced parts would wear more per unit of unreduced surface, thus compensating for the effect of the empty spaces of the reductions. If, on the other hand, one worked with such a pressure that an increase of pressure did not noticeably augment the wear, the effect of the reduction would rapidly manifest itself.

Surfacing with cut-away polishers is, primarily, work with a system of unequal wear. It demands a very frequent supervision of the deformation in order to arrest the polishing just at the moment when the surface has become correct. By arresting the operation some minutes too late the surface will become marred by faults contrary to those which it is wished to correct. It is, then, a practice to be prescribed in mass production. For such manufacture it is absolutely essential to modify the overlap, the track, the speed or the pressure judiciously in such a way as to obtain a more or less even wear. But when a surface with a rather high precision (a proof plate of 15 cm. diameter, for instance) is to be polished, it is rarely that one can avoid recourse to cutting away, because there are almost always imperfections of the tools or heating effects (which are very noticeable in large lenses during polishing) to be corrected.

When at the commencement of a batch of work one regulates a machine for pitch polishing, a light cutting away can furnish valuable indications of the adjustment of the machine. With a knife, two diametrical, crossed furrows are cut in the polisher and the machine is given an increasingly high speed of rotation until one observes that, the pitch being softened, the furrows begin to fall in. This observation furnishes the following information.

(1) The last speed attained is too great for the hardness of the pitch. It will be necessary, in correct production, to adopt a lower speed or a harder pitch.

(2) If the furrows are equally filled in throughout their length, the driving socket has been cut to the optimum depth (curved tools) and the tools and lens carrier are sufficiently rigid.

(3) If the furrows are closed up again in the central part and not on the zone, then the tool or the lens holder bends under the pressure.

(4) If the furrows are closed up again on the crown and not in the central part, then the socket hole is too far above the rubbing surface (curved tools) since it is a proof that a couple has crushed the polisher on the zone.

### Cylindrical Surfaces

When the trued cylindrical lens is fixed on the lens carrier, or when a block of roughed or trued glasses is formed, it is necessary for the axis of the glass or the block to be sensibly parallel to the plane of the guides, that is to say, to the axis of the lens-holder. If, in fact, this condition is not fulfilled, a large part of the time occupied in smoothing will pass in bringing back the axis of the surface in the direction of the guides, the duration of the operation will be much increased and the tool will be rapidly deformed.

To place the axis of the glass or the block correctly, the block is formed by moulding it by pressure of the tool, the guide rods being engaged in the forks. The following method can be used. Having measured the thickness which the layer of glass and cement should have at the edges of the lens carrier, one chooses four steel balls, all of the same size, of a diameter almost equal to the thickness of the cement-glass layer. A ball is put in position at each corner of the glass holder and held by a little warm cement; the block is formed (or the glass is stuck on) by pressing with the counterpart until it bears on the four balls. Afterwards the four balls are removed.

The perfection of the work depends, on the one hand, on a very exact observation of the optimum pressure, and on the other, on the perfection of the tool and of its guidance.

It is more important to apply the optimum pressure for surfacing a cylindrical lens than for surfacing a flat or a spherical lens. In fact, if Fig. 25 represents a sectional diagram of a block of spherical lenses covered by its concave tool, the resultant of the elements of friction, whatever the movement given to the tool, will be applied at a certain point situated a little above the summit *A*. By placing the socket and its ball joint pin at that point the tool will be guided without an upsetting couple. Let us suppose, now, that the

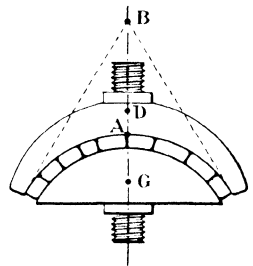

FIG. 25.

same figure represents a block of convex cylindrical lenses, viewed from one end and covered with the concave tool. When the concave tool is pushed in the plane of the figure, the resultant of the elements of the frictional forces is applied at a certain point  $D$ , situated between the limiting positions  $A$  on the surface to be worked and  $B$ , the intersection of the symmetrical tangents from the edges.

When this concave tool is pushed normally to the plane of the figure, that is to say, parallel to the generatrices, the resultant of the elementary forces of friction is at the centre of gravity  $G$  of the surface of the tool.

When one is working a cylindrical block, the point of application of the forces of friction oscillates constantly between the point  $D$  and the point  $G$ . The fulcrum at which the effort of the ball pointed pin which guides the tool is applied is hardly ever on the resultant of the frictional forces; as a result there is, almost constantly, an upsetting couple which transfers the maximum pressure now to one side of the tool, now to the opposite side. It is in the direction of the axis that the upsetting couple is strongest. Each edge is alternately in advance or behind with reference to the direction of displacement. In order for the effects of these alternations to compensate, the increase of wear produced by an increase of pressure  $K$  on the edge in front of the tool should be equal to the reduction of wear resulting from the reduction of pressure  $K^1$  on the opposite edge. Thus  $K$  and  $K^1$  are continually varying with the upsetting couple and it is impossible to predict their respective values at a given moment, for they depend essentially on the elastic deformations to which the system is susceptible. It is principally the layer of cement on which the glasses lie, whose elasticity is more or less elastic according to its degree of "cooking", its composition and its thickness. As one is obliged to find the optimum pressure empirically, the same mallet pitch must be used for this determination and the subsequent work of surfacing, and the thickness of the layer must always be the same from one block to the next. The optimum pressure is found to be a little above the minimum pressure (the minimum pressure is that below which the abrasive ceases to bite to any appreciable extent), for the following reason.

It is known that, commencing with this minimum pressure, the wear first increases quickly with the increase of pressure, and then less and less quickly until it does not increase any more from the moment when the grain of abrasive is completely immersed in the tool and in the glass.

The course of the curve of wear as a function of pressure must be closely that of Fig. 26. Let us suppose that the mean pressure is represented by the abscissa of the point  $M$ , the pressure on the front edge by the abscissa of the point  $AN$  and the pressure on the rear

edge by the abscissa of the point *AR*. The wear of point *AR* is little less than that of point *M*, which is itself very much lower than that of the point *AN*. The mean wear of the edge is, then, measured by the ordinate of the point *N* situated in the middle of the ordinate *AN*. It is greater than that of the point *M*. From this must result a surface which is either too convex or not concave enough. On the other hand, there would be, theoretically, a greater wear at the centre than at the edge if one worked with a mean pressure very close to the maximum pressure, but the phenomenon would be practically unobservable, because under such a working routine, the greater part of the energy employed would be transformed into heat which would deform the surfaces of the tool and the glass. Between the two extreme values

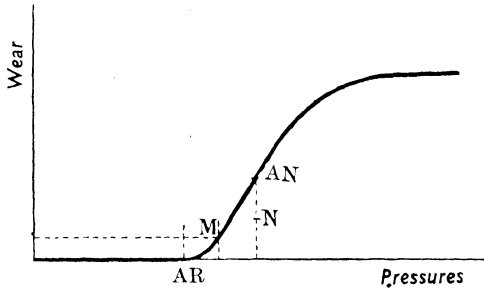

FIG. 26.

of the mean pressure, there is certainly one for which compensation of wear establishes itself for a given value of the upsetting couple. It cannot be far away from the minimum pressure, on account of the form of the curve of Fig. 26; that is all that one can say, but that is practically sufficient for finding a satisfactory enough pressure fairly quickly. If, in a general way, the wear is greater towards the edges with a low pressure in spite of a slight overlap, the trial of a slightly heavier pressure is indicated.

The perfection of the tool cannot be absolute, any more than that of spherical tools, but it is possible to surface glasses with a perfection superior to that of the tool by taking care to avoid the same point on the tool coming periodically over the same point on the glass, for, with this precaution, the small inequalities of the tool compensate themselves very noticeably. For this reason the same rule is observed as for spherical surfaces, to give to the movement of translation a period which has no common measure with that of the rotation of the tool. For this, count the number of turns of the tool per minute and the number of oscillations of the ball pointed driving pin; the two

numbers must be in a ratio which is neither  $1/1$  nor  $1/2$  nor  $3/4$ , but, for example,  $16/17$ ; the adjustment is made accordingly.

The perfection of the tool does not only depend on the work of correction, but on the correctness of the forks and of the guide rod. If the axis of the forks merges exactly with the axis of the tools, the rod does not slide up and down but only in the direction of its length and there is no advantage in the forks being closely parallel. But if the curvature is shallow, the forks cannot be axial with the axis of the tools; a vertical movement of the guide rod results from this lack of correspondence between the axes and necessitates a rigorous parallelism of the forks. If the parallelism is defective, the axis of the upper tool oscillates about the axis of the lower tool, and this movement causes a deleterious wear at the angles of the tools. It is, then, a matter of the first importance to rectify the parallelism of the forks meticulously. This parallelism obtained, it remains to obtain a rigorous parallelism of the axis of the forks, on the one hand, and of that of the guide rods on the other, with the axis of the tools; but such an adjustment would be senseless if the cylinders were not previously corrected perfectly. It would be, moreover, extremely difficult, even if the surfaces were perfect, for flexure must be taken into account. Happily a prolonged grinding together of the tools resolves these difficulties. It is found, on commencing grinding together, that two opposite angles of a tool wear more than the rest of the surface. If the parallelism of the forks is imperfect, wear of the four corners can even be found. If the direction of rotation of the lathe is changed the most marked wear changes diagonally, because the play of the guide rod in its forks intervenes, as well as the torsion of the rod which joins the forks. Even with well-adjusted forks, oscillating around an axis parallel to the axis of the tool, the torsion of the rod which joins the forks and the flexure of the rod which slides through the forks, suffices to produce a more rapid wear of two opposite angles of the tools and the blocks, for the following reason. It is known that when a disc is displaced by means of a central ball pointed pin on a rotating flat tool, but without overlapping, it automatically assumes a speed of rotation equal to that of the lathe. If two parallel arrows are traced on the disc and on the flat tool, these arrows remain parallel during working. The same effect is produced when the disc and the plate have cylindrical surfaces, whose axes can be shown by two arrow marks. Theoretically, there would be no need of forks and guide rods to maintain the parallelism of the axes of two rubbing pieces comparable to two plates, that is to say, cylindrical pieces of small angular aperture, the lower piece being larger than the other, when working without overlap. But as soon as one piece overlaps the other, the speed of rotation of the upper piece tends to decrease, thus breaking the parallelism of the axes; it is then

that the forks and the guide rod come into play to maintain parallelism, in spite of the couple which tends to slow up the rotation of the upper piece. This couple is always in the same direction, that is to say, in a direction contrary to the direction of rotation of the lathe. It has the effect of slightly warping, by flexure and torsion, the rectangle constituted by the forks and the rods and, as a result, of augmenting the pressure on two diametrically opposed corners of the rubbing pieces. By changing the direction of rotation of the lathe one can make the excess of pressure bear on the two other corners. A frequent change of the direction of rotation is thus indicated in order to make the excess pressure bear alternately on two corners and then on the two others.

The following rules result from the foregoing observations.

(1) To grind together the cylindrical tools or for surfacing cylindrical blocks when working with overlap, the forks and guides being perfectly adjusted and regulated, the direction of rotation of the lathe must be reversed frequently and the added weights which should produce mean optimum pressure must be carefully determined. The lenses forming the corners of the blocks are sacrificed.

(2) To surface a block of concave lenses with precision on a cylindrical convex tool, the dimensions of the block must be very much smaller than the dimensions of the tool in order that the lenses never overlap or hardly overlap at all. Under this condition there is no abnormal pressure at the corners of the block and all the lenses in the block can be equally good.

(3) To surface with precision a block of convex lenses under a concave cylindrical tool, the tool must be much smaller than the block in order that it shall never overlap and shall not create the couple which can cause two corners of the tool to work excessively.

As the concave and convex tools are generally of the same dimensions so that they can be ground together easily, the above rule is only applicable to the smoothing operation if one has at one's disposal a concave smoothing tool smaller than the block to be surfaced, but it remains practicable for polishing. The polisher must not cover the whole surface of the tool; it will have such dimensions that it never overlaps the block. It is as well to have a special smaller tool for smoothing, but one must have a larger tool of the same curvature for trueing and for placing on top of the glasses in forming the block.

The polishing will be executed with a polisher reduced to the dimensions of the block of concave lenses described above (in (2)), that is to say, it will be small enough never to overlap. The part of the convex block overlapping the tool will be composed of blocks of glass a little softer than the glasses to be worked, since these blocks will only be ground alternately.

The adjustment of the forks and of the axes would be illusory if the polisher were "off axis". It is, then, *indispensable*, in making up a cylindrical polisher, to employ the precautions recommended in Chapter II for centring the surface of the polisher. The cylindrical polisher can be of pitched cotton wool, or one could also use a fine cloth soaked in pitch and squeezed out in such a way that there remains a small thickness of pitch on the side which is to adhere to the tool. Four blocks of equal thickness (or better, four steel balls) are placed one at each corner of the tool near the terminal generatrices. These blocks or balls are chosen of the thickness which one wishes to give to the polisher near to the rectilinear edges. The polisher is moulded by pressing the counterpart on to the cloth until it bears on the four blocks after having caused the excess of pitch to run from the edges of the cloth.

The preceding rules can be summed up in a few words. *Arrange for the forks to do the least possible amount of work.* They should hardly intervene unless the glasses no longer bear equally on the tool, or the abrasive paste is irregularly distributed. If one cannot avoid making the forks work systematically, it is necessary to overlap very little and set blocks (protectors) in place.

When plano-cylindrical or bi-cylindrical lenses are to be made, precautions should be taken to see that the axis of the second surface shall be parallel to the axis of the first or to the plane surface (in plano-cylindrical lenses). This result may be precisely obtained in the following way.

In principle, the lenses are trued and surfaced in a square or rectangular form, two sides being parallel to the axis. They are only edged to round discs (if such are required), after centring, in the last operation. One of the sides is carefully smoothed, after trueing, and brought to rigorously equal thickness from one end to the other; it gives two edges which must serve as reference marks for the direction of the axis right to the end of the operations. The opposite side is smoothed in the same way, but in addition one assures oneself, by resting the trued lens on a plane, that the edges are parallel to those of the opposite side and separated from one another by the same thickness of glass.

In order to block the lenses ready for surfacing they are aligned on the blocking tool by the aid of a rule engaged in the forks and against which the smoothed sides are pressed; the block is then moulded by means of the tool, as has been said above.

When the block of lenses is formed for working the second surface, the precaution which was taken of smoothing on each lens two sides of the same thickness assures parallelism of the axes of the two surfaces, on condition that the tool, in moulding the block, bears well

on the edges of the smoothed sides. In order that this may be so, the radius of the trued surface must be shorter than that of the convex tool (or longer than that of the concave tool). Without this the blocking tool will bear on the lenses by any part whatever except the edges. From this it results that the surfaces wear progressively from the smoothed sides up to the medial generatrix, which is attacked the last by the abrasive and is left smoothed as a "cordon" (or witness). If, for reasons of surfacing, it is preferred that, on the contrary, the wear shall progress from the medial generatrix, the surfaces to be smoothed should be trued with a longer radius than that of the convex tool or shorter than that of the concave tool. In this case one must assure oneself that the commencement of the surfacing leaves on the lenses cordons which are quite parallel to their edges, which are reference marks for the direction of the axis. If this is not so for all the lenses, the block must be warmed slightly and the positions of the badly levelled lenses rectified.

When, exceptionally, one is obliged to surface lenses already edged to circles, care must be taken, after surfacing the first surface, to mark on each lens the extremities of a generatrix passing close to the middle of the lens. For this purpose use is again made of a rule engaged in the forks, against which a marking diamond is slid along. It is equally convenient to stick several glasses in file on a rectangular strip of glass, whose large sides are parallel to the axis of the surface to be produced.

Operating according to the principles set forth for working rectangular cylindrical lenses, one makes use of these diamond marks as the edges of the smoothed sides.

### **Toric Surfaces**

A toric is a surface generated by a sphere turning around an axis which does not pass through its centre. The exterior surface of a motor car inner tube gives an image of it. In optics only a narrow region of the surface, that which is saddle-like on the outer great circle of the toric (equator), is utilised. If a concave tool is moulded on a part of such a region, the slightest transverse displacement will prevent it resting in contact at all points with its convex counterpart. One could not then, rigorously, grind together the concave and convex toric tools except by oscillations following the equator (one says, "following the axis of the toric" by analogy with cylindrical surfaces) without transverse displacement, but thus a surface marred by numerous longitudinal grooves would be obtained, furrows cut by the microscopic high spots of the tools. In order to efface these grooves, an oscillatory movement normal to the axis must be combined with the movement along the axis, and it is made so that the period of transverse oscillation has no common measure with that of the longitudinal

oscillation, in order that a high spot on a tool shall never pass again over the same points on its counterpart. If the transverse oscillation is very short the surface obtained differs very little from a toric. As for the longitudinal oscillation, that can be very long, but, unfortunately, the machines generally employed for surfacing toric lenses only permit equal longitudinal and transverse oscillations, in order that the duration of polishing shall not be too long. The surfaces thus obtained in spectacle work and known as torics are not really torics, but approach them very closely.

To produce precision toric surfaces, special automatic lathes are necessary permitting long oscillations along the axis to be given to the glass (or to the tool) and very short oscillations normal to the axis of the cylinder, as can be done on the lathes of adjustable relative rotation of the Institut d'Optique (see p. 158).

### Thermal Deformations

Let us consider, for example, a convex tool of section  $ABCD$  (Fig. 27), and let us suppose that, with a Bunsen burner, the surface  $AB$  is warmed for some seconds. This surface expands while the surface  $CD$ , still cold, will not have altered. The points  $C$  and  $D$  being fixed, the effect of the expansion will then be to open the angle  $AOB$  more; the convexity of the tool will increase. Thus a plane tool warmed on the working surface becomes convex; warmed on a face bearing the screwed boss, it becomes concave. The deformation takes place in accordance with the same law for concave or convex tools.

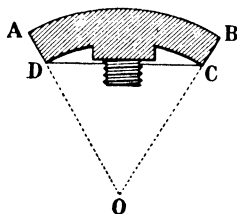

FIG. 27.

The manner of heating blocking tools is not unimportant. Let us suppose that a concave block is being formed while heating the concave face of the blocking tool. This tool, being warmer on the concave side than on the convex, opens; now it is in this state that the block is moulded on the convex tool, which is cold. When the block is properly cold the concave blocking tool will have regained its shape of equilibrium; that is to say, it will be a little closed. In this new condition the block will no longer bear, except by its edges, upon the

convex smoothing tool. There is, then, a chance that it will only bear upon the polisher at its edges.

If, instead of warming the concave blocking tool on its concave face, it is warmed on the other face, the block will be opened a little in cooling and will no longer bear at its edges on the convex tool. It will roll on it, so that one "scours" it in working, a method of working which should only be employed exceptionally and purposely. Heating the blocking tool on both surfaces but rather more on the side of the lenses is then indicated.

These considerations are exactly applicable to the making of polishers. If, in preparing a polisher, the tool is warmed on the polisher side in order to form it on a cold counterpart, the polisher will close up in cooling and "take at the edges". That is to say, make contact at the edges with the glass, while its centre will not touch it until after working for some time. If a polisher which does not "take at the edges" is wanted, both faces must be heated in making it. It results from these thermal phenomena that the common procedure, which consists of heating the tools on stoves or with Bunsen flames, for making blocks or polishers, is not as good as heating the tools in a furnace, or, better, in an oven. If they are heated on a stove they must be heated for a long time and allowed to cool a little before running in the cement. Working thus the temperature is allowed to equalise itself in the metal before the block or the polisher are moulded.

It will be gathered, in short, that the worker has at his disposal a convenient means of producing a polisher which takes in the middle or at the edges at will. It is sufficient, in the first case, to heat the tool quickly and strongly on the face to which the handle is fixed before moulding the polisher or, if it is desired to obtain the opposite effect, to heat it on the polisher side. This artifice is more rational than that of relieving (or cutting away) the polisher, for if, for example, the centre of the polisher is not completely relieved, it will continue to take in its central region on the high spots that will have been formed, and on the other hand, the more relieving is done the more the pressure per unit surface is increased.

The slightest variations of temperature localised at some point of an optical part deform it. If, at the moment of blocking, one is so imprudent as to touch a hot glass with a wet finger, one risks splitting it. If a plane glass is resting on a proof plane and one grips the glass by one's fingers for a few instants, the regions warmed by the fingers expand and optical methods (interference fringes) allow those expansions to be seen and measured. One can only judge the quality of a surface after having let it acquire the temperature of the room and of the test plate with which one wishes to compare it.

It will be understood, then, that the warmth produced by the fric-

tion of the glass on the tool suffices to alter the surface. In accordance with this a surface worked industrially, that is to say, with a need for speed, must appear to be a little too convex at the moment when it is removed from the polisher in order that it shall be good when it has cooled.

When the tool is warmed for preparing the polisher it is deformed, and one must wait long enough before making use of it.

Recourse may be had to local heating for correcting a lens. By heating a region of the lens it is made to project. If it is worked at once the projection is worked down and this result is visible after cooling.

If it is desired that a tool shall bite more at the edges it can be heated on the side where the screwed boss is.

The heating of the tool and of the lens, produced by friction, is a function of the work done per minute and, in consequence, of the pressure and the speed. Taking into account the optimum pressures indicated in Chapter II, one cannot exaggerate the speed without producing a harmful warmth.

Variations of temperature affect the pitch of the polishers and the mallet pitch very much. A too warm polisher deforms. This property is utilised at the commencement of polishing in order to mould the polisher well on the smoothed glass (or on the block) by commencing to polish before the polisher is completely set. The speeds must, then, be adjusted to keep the temperature below that of malleability of the pitch.

The black cement used for forming the blocks warms up in the course of polishing, by contact with glasses worked too energetically. Towards the end of a wet, the heat of friction and the too close adhesion of the polisher can cause the cement to flex in such a way that the lenses turn over slightly in the direction of the frictional resistance. When this is detected one can sometimes restore the glasses to a suitable uprightness by reversing the motion of the lathe. This practice is hazardous; recourse to it should be avoided.

On the contrary, when the work is interrupted at the end of a work period, the blocks of glass cool down during the night and the next morning the glasses are no longer as rigorously centred as they were the previous evening. The lens carriers must be made lukewarm by heating them lightly from below and recommencing work with care to correct the centring of the glasses by pressure of the tool.

### **Elastic Deformations**

It is important that a precision glass shall never be submitted to external forces. If, when once mounted in an instrument, it is subjected to pressures by its mounting, especially if those pressures are unsymmetrical, it will be deformed and will lose its optical qualities.

If, during surfacing, a glass is compressed or stretched by the cement which holds it, it can present a perfect surface when one examines it still blocked on the lens carrier, but once freed from its cement it resumes its natural equilibrium and its surfaces are no longer good. This phenomenon is shown, above all, by concave lenses, which are usually thin in the centre. It is very noticeable in concave cylindrical lenses which present a thin medial band. The forces of the cement on these thin parts are dangerous. They can be avoided by putting under these thin places some little pieces of paper which prevent the cement from adhering to the glass in those regions. The glass, then being held only by its thick parts, does not deform.

### Working Metallic Mirrors

Metallic mirrors go back to the furthest antiquity. If the technique of their production has become forgotten, it is because, for many centuries, glass mirrors have replaced metallic mirrors.

The procedure of our ancestors can be recovered by searching in old optical treatises.

One finds, in this way, an account of the technique of working metallic mirrors in the *Cours complet d'optique, traduit de l'anglais de Robert Smith* (1767). This technique differs considerably from the technique followed at the same epoch for working glass surfaces. Here, evidently, are the reasons. To work glass, a tool of soft metal was chosen (soft iron wire for bow-sawing, convex or concave tools of brass) because the grains of emery embedded themselves of their own accord in this soft metal. But if the surface to be worked were softer than or nearly as soft as the tool, the grains of emery would also cut lodgments in the smoothed surface. Certain grains would embed themselves fairly solidly and then, detaching themselves during the polishing operation, they would spoil the polish.

In all cases it is necessary that the abrasive employed in polishing shall not be able to agglomerate into minute balls capable of forming their imprint on the surface to be polished before breaking down under it.

Though then one can, if necessary, work hard steel as one works glass, different means must necessarily be employed for polishing a softer metal.

*Trueing.* Rough by milling. True with a stone tool of large grain size (convex, plane or concave tool) whose diameter is to that of the mirror as 6 is to 5. Use less and less coarse emery and in small quantities, changing it frequently.

Remove as little as possible of the "crust" of the mirror, for that crust is harder and more easily polished than the core.

*Smoothing.* This is not done with emery but with blue-stone (lazulite, sharpening stone, or Turkey stone).

Cut this stone in small pieces. Block them on a tool like lenses to be worked in a block. Surface these stones on the counterpart (concave, plane or convex tool), using emery in such a way as to obtain a block of stones of the curvature of the desired tool, or plane. In a word, treat these stones as one would treat lenses in smoothing.

To smooth the mirror, use this block with no addition of emery. Wash and rinse frequently during the work, to remove the slime or the traces of emery which can come from the surfacing of the block of stones.

The channels which exist between the stones, constituting lodgments for the excess of mud, perform the same role as the grooves of large reticulated tools. This arrangement is advantageous, for the mud evacuates itself imperfectly when one makes use of large tools of continuous surface and can form harmful concretions.

*Polishing.* Choose a fine and very smooth piece of taffeta, a little larger than the polisher (plane, convex or concave). Apply it to the polisher, the edges folded on the circumference. Iron away all the creases with a hot iron and stretch it carefully; remove knots and irregularities. With a brush soak the taffeta all over, as evenly as possible, with a fairly strong solution of pitch in alcohol. Let the alcohol evaporate and begin again. If some bubbles remain under the taffeta try to remove them with the point of a needle. Continue to soak the taffeta until it adheres throughout to the polisher and is quite filled up with pitch. Leave it to dry for some days in order that the pitch may harden.

To avoid waiting several days one can work as follows.

Stretch over the first piece of taffeta a second piece. Warm the polisher and its taffeta. Heat some pitch separately and strain it through a piece of cloth. Pour this strained pitch, very hot, on the polisher covered with these two pieces of taffeta, but only pour on the quantity necessary for well soaking the two pieces. Keep the whole warm enough for the pitch to spread and penetrate well. Remove, while it is liquid, all the pitch which will not penetrate and make use, for this, of a hot cloth applied to and pressed on the taffeta. After cooling strip off the exterior piece of taffeta and cut off the useless edges of the first piece.

To remove a part of the pitch from the regions where it is too thick and to give a regular surface to the polisher, rub it on its counterpart (plane, concave or convex tool) with a little soap and water until it becomes a fairly dark brown. Wash and begin again with more soap and water until the taffeta appears throughout with as uniform an aspect as possible. The work can be accelerated by putting a few drops

of alcohol into the water or by removing the pitch with a knife in the regions where it is too thick.

*Take great care to protect these polishers against dust, and above all, do not let any emery or filings get near.*

After use for some time, these polishers do not work as well; rework them on their counterpart with soap and water (without alcohol), then, after drying, spread a little of the solution of pitch referred to at the commencement of these instructions, with a brush.

Polishers covered with taffeta are used with a little putty powder (very finely divided) and clean water. When a polisher is beginning to dry the mirror clings to it more and the polishing is quicker. But if the polisher is too dry the taffeta may tear and if the pitch and the putty powder mingle here and there in little lumps, the work is immediately spoiled. When the taffeta becomes dry in some spot, moisten that spot with a quill feather soaked in very clean water.

The same putty powder can serve for at least a half-hour.

Every time some fresh putty powder is added, it must be rubbed with a "bruiser" before being used on the mirror (a counterpart is set aside for this operation) to break down the large lumps which could scratch the mirror in polishing it. The mirror and the polisher being quite moist, put them in contact at their edges, make them slide on one another to bring their centres together and recommence the work.

With but little putty powder at a time the work takes a very long while; with too much putty powder the mirror will be deformed towards its edges.

If the mirror is larger than 30 cm. in diameter the work demands a considerable pressure, so fatiguing that recourse to a machine is recommended (the machine referred to in Smith's treatise has no rotary movement, but only translatory movements made by hand, the pressure being given by weights suspended from the tool and hanging under the piece to be surfaced).

### EXAMPLES OF EXERCISES ON CHAPTER III

#### First Exercise

Calculate the additional weight to be placed on the triangle of an automatic machine, 1st, for smoothing and 2nd, for polishing on pitch, being given:

- (a) The weight of the block and its support.
- (b) The number of pieces blocked and the dimensions of each of them.

Let 2 kg. 500 gm. be the weight of the block of 17 lenses each 40 mm.

in diameter; and 1 kg. 200 gm. the weight of the guiding triangle of the machine.

The surface of one lens =  $\pi \times 2 \text{ cm.}^2 = 3.14 \times 4 = 12.56 \text{ cm.}^2$ .

The surface of 17 lenses =  $12.56 \times 17 = 213.5 \text{ cm.}^2$ .

The load of 2500 gm. + 1200 gm. (= 3700 gm.) is distributed over 213.5 sq. cm. which gives a pressure of  $\frac{3700}{213.5} = 17 \text{ gm. per sq. cm.}$

This is too low for lenses of this sort; an additional load of 1 kg. which raises the pressure to 22 gm. per sq. cm. can be put on the block.

### Second Exercise

Calculate the minimum surface of a glass of 3 cm. thickness which can be polished on pitch, placed on top of the tool; the glass being stuck to a cast iron disc 1.5 cm. in thickness and 15 cm. in diameter.

Also the same question but having in view the use of a paper polisher.

Let  $x$  be the radius of the glass in centimetres.

2.5 the specific gravity of the glass.

7 the specific gravity of the cast iron.

400 gm. the weight exerted on the glass carrier by the guiding triangle (this triangle being partly balanced by a counterpoise).

The cast iron disc weighs:  $3.14 \times 7.5^2 \times 1.5 \times 7 = 1854.5 \text{ gm.}$

The glass disc weighs:  $3.14 \times x^2 \times 3 \times 2.5 = 23.5x^2 \text{ gm.}$

The weight of the triangle = 400 gm.

The total load on the tool =  $(2254.5 + 23.5x^2) \text{ gm.}$

The bearing surface =  $3.14x^2 \text{ sq. cm.}$

Hence the pressure =  $\frac{2254.5 + 23.5x^2}{3.14 \times x^2} \text{ gm. per sq. cm.}$

This pressure ought not to exceed 9 gm. per sq. cm. for pitch polishing or 35 gm. per sq. cm. for polishing on paper.

Thence one has the equations:

$$(3.14 \times 9 - 23.5)x^2 = 4.7x^2 \geq 2254.5$$

and

$$(3.14 \times 35 - 23.5)x^2 = 86.4x^2 \geq 2254.5,$$

from which

$$x \geq 21.8 \text{ cm. for polishing on pitch.}$$

$$x \geq 5.2 \text{ cm. for polishing on paper.}$$

Thus one cannot place on this tool a glass of 30 mm. thickness having a diameter less than 436 mm. if one wishes to polish on pitch. In practice this is too greater a diameter for the lens to be able to be surfaced with the tool below. But, for polishing on paper, one can place on the polisher a disc of 3 cm. thickness having at least 10 cm. diameter,

the glass being fixed on the lens carrier referred to. If the lens were of a larger diameter it would be necessary also to put on an additional weight.

### Third Exercise.

Calculate the maximum diameter of a cast iron tool (specific gravity 7) and that of a tool in aluminium alloy (specific gravity 3), both of a mean thickness equal to  $\frac{1}{12}$  of the diameter for pitch polishing large lenses under the tool.

The triangle of the machine is supposed to be balanced by a counterpoise and the weight of the pitch is neglected.

Let  $x$  be the radius of the tool in centimetres.

The weight of the cast iron tool is equal to:

$$3 \cdot 14x^2 \times \frac{2x}{12} \times 7 \text{ gm.}$$

The bearing surface is equal to  $3 \cdot 14x^2$  sq. cm.

The pressure, which is the quotient of these two quantities, ought not to exceed 9 gm. per sq. cm.

One has then

$$\frac{7x}{6} \leq 9,$$

from which

$$x \leq 7 \cdot 7 \text{ cm. and the diameter } \leq 154 \text{ mm.}$$

If the tool were in aluminium alloy its diameter could be as much as  $154 \times \frac{2}{3} = 360 \text{ mm.}$

### Fourth Exercise

One has to surface a block of binocular prisms 250 mm. in diameter, containing 76 prisms, whose faces to be worked are  $25 \times 15$  mm. The cast iron tool is 300 mm. in diameter by 16 mm. thickness. The triangle weighs 1200 gm. on the tool. After having smoothed, a pitch polisher 270 mm. in diameter is made. Should an additional weight be used for the smoothing or for the polishing?

Say how the adjustment of the machine will be determined (course of the grinding pin, speeds, etc.).

The bearing surface is  $2 \cdot 5 \times 1 \cdot 5 \times 76 = 285$  sq. cm.

The weight of the tool = 7913 gm.

The weight of the triangle = 1200 gm. } total = 9113 gr

The pressure =  $\frac{9113}{285} = 31$  gm. per sq. cm.

This pressure, admissible for trueing, is too great for smoothing. The brass smoothing tool (density 7.7) should only be 12 mm. thick at the edge and 15 mm. thick near the central shoulder. Moreover, about 1 kg. of the weight of the triangle should be balanced by a counterpoise. The pressure thus reduced to about 25 gm. per sq. cm. will still be too great. The machine is driven at a speed a little below normal during smoothing, in order not to heat up the prisms too much, and a polisher is made on a lighter tool, not more than 270 mm. diameter, if possible. For the following block one endeavours to put the prisms closer together, in such a way as to exceed the number of 76 prisms, in order to augment the bearing surface.

*A priori* the movement of the triangle is regulated so that at each stroke the tool uncovers about 10 to 12 mm. on one side and from 15 to 20 mm. on the opposite side, the centre of the tool passing within about 10 mm. of the centre of the block. The ratio of the radii of the tool and the block being equal to 1.2, the block should (for perfect mixture of the abrasive) be uncovered to the extent of 45 mm. at each oscillation, but such an adjustment would render the block convex, as much by the effect of out-of-plumbness as by the effect of slowing down the rotation of the tool.

The course of the triangle being determined, one replaces the block by a flat tool that has been coated with polishing rouge and substitutes for the driving pin a pointed piece of wood which rests on the flat tool. The machine being set in motion, one examines the spirals described on the disc by the wooden point, and modifies the speed of the triangle until the spirals described are approximately equally spaced and are not superposed before a great number of turns have been made.

### Fifth Exercise

Determine the dimensions of the tools and blocks for surfacing some bi-convex lenses of 45 mm. radius, 30 mm. diameter and 7 mm. thickness, supposing in turn that common magnifiers, and then object glasses, are to be made.

The roughing with emery is done piece by piece and to the radius of 47 mm., for in edging one can diminish the "edge off" effect.

Then the glasses are blocked on a convex tool of about  $130^\circ$  angular aperture and of 36.5 mm. radius. For the magnifiers, as well as for the objectives, a cast iron concave tool of about  $130^\circ$  aperture and 45.5 to 46 mm. radius is used for trueing.

To surface the magnifiers one makes up blocks of  $125^\circ$  aperture. One smooths with a cast iron tool of the same aperture and of 45 mm. radius, thick enough to realise easily with a small excess weight a pressure of 50 gm. per sq. cm. (an example of the calculation of the thickness and the additional weight has been given in a previous exer-

cise). The overlap will be 20 mm. to one side and 25 to the other. One polishes on cloth or on felt on a tool of the same aperture and 47 to 48 mm. (felt) radius (2 or 3 mm. being included for the thickness of the polisher).

For surfacing objective lenses, blocks of  $90^\circ$  are made up and are smoothed with concave tools of  $120^\circ$  under a pressure of 20 gm. per sq. cm. for 20 minute emery and 15 gm. per sq. cm. for 60 minute emery. The overlap will be nil on one side and 10 mm. on the opposite side. Polishing is done on pitch under a pressure of 15 gm. per sq. cm.

### Sixth Exercise

Determine the dimensions of the tools and the adjustments for surfacing with precision a plano-cylindrical lens of 100 mm. radius, 10 mm. in length along the axis, 60 mm. transversely and 7 mm. in thickness.

A rectangular block is formed with packing pieces around the glasses. The packing pieces at the bottom are  $60 \times 10$  mm., and the pieces parallel to the large sides of the glass will be  $120 \times 10$  mm. The smoothing tool or its useful part and the polisher will be  $95 \times 55$  mm., and their course will be such that they do not overlap the blocking pieces and that the middle of the trajectory of the tool will be slightly eccentric with reference to the axis of the lathe. The lens carrier will be cylindrical with a radius of 91 mm. Steel balls 9 mm. in diameter serve as stops during the moulding of the block in such a way that its axis will be parallel to that of the lens holder. To this end, the packing pieces are broken off at the four corners of the block to permit the balls to embed themselves in the cement during the formation of the block. The polisher will be made of pitched billiard cloth; balls of 2 mm. will serve to assure the adjustment of its axis.

## CHAPTER IV

### SPECTACLE LENSES

#### **Ametropia**

Spectacle lenses serve to correct ametropia, that is to say, faults of vision. An eye without visual faults is said to be emmetropic.

The principal faults of the eyes are: myopia, hypermetropia, presbiopia, astigmatism and strabismus.

The myopic eye is too convergent; it only sees very nearby objects sharply. This ametropia is corrected by more or less strongly divergent lenses.

The hypermetropic eye is too little convergent; it sees objects which are not far away badly, and does not even see objects situated at infinity clearly (the horizon, the moon). This ametropia is corrected by convergent lenses.

The presbyopic eye is one which has lost its power of accommodation. Children can clearly see objects very close to them or very far away. As a man's age advances he can no longer see very close objects clearly, but continues to see clearly objects afar off; he becomes presbyopic. This ametropia is corrected by lenses appropriate to the distances for which the eye can no longer accommodate.

Astigmatism is a defect of vision which results from the surfaces of the eye, and especially of the cornea, not having the same curvature in all sections containing the line of sight. This ametropia is corrected with cylindrical, sphero-cylindrical or toric lenses (see later) which have slightly different curvatures in two mutually perpendicular sections.

Strabismus is a defect of parallelism of the optical axes of the two eyes (squint).

#### **Power of a Lens**

All these corrective lenses are defined by their powers. The power of a lens (spherical or cylindrical) is the reciprocal of its focal length just as the curvature of a surface is the reciprocal of its radius of curvature.

The powers of lenses, like those of the eye and its defects, are measured in diopters.

There are spherical diopters and cylindrical diopters (for astigmatism). There are also prismatic diopters (for strabismus) according to a special definition (see p. 106).

### Ordinary Diopters

1 diopter is the power of a lens of 1 metre focal length.

A lens of  $p$  diopters has a focal length  $f$  equal to  $\frac{1 \text{ metre}}{p}$ .

For example, a lens having a focal length of 2 metres has a power of  $\frac{1}{2}$  diopter.

The powers of spectacle lenses are expressed in diopters, half-diopters, quarter-diopters, and even in eighth-diopters for lenses of very slight power.

The diopters are prefixed with a + sign or a - sign according to whether they concern convergent or divergent lenses.

$n$  being the refractive index (for yellow light) of the glass used, the power of a plano-spherical lens is  $\frac{1}{f} = \frac{n-1}{R}$ . Its curvature is  $\frac{1}{R} = \frac{1}{(n-1)f}$ , where  $R$  represents the radius of curvature of the spherical face.

The power of a biconcave or biconvex lens (a "bi" lens) of equal curvatures is  $\frac{1}{f} = \frac{2(n-1)}{R}$  and the common curvature is  $\frac{1}{R} = \frac{1}{2f(n-1)}$ .

The refractive index of the glasses generally used in spectacle work is 1.527. If, in approximation, one assumes  $n = 1.5$ , then  $2(n-1) = 1$ , thus the curvature of a "bi" lens is measured by the number of its power; in other words, the radius of its surfaces is equal to its focal length.

The power of a plano-spherical lens is the half of the power in diopters read on the spherometer for "bi" lenses, but there are also spherometers \* graduated for plano-spherical lenses.

Any bi-spherical lens can be considered as being formed of two plano-spherical lenses placed back to back, whose powers add or subtract (meniscus in the latter case).

The power of a "bi" lens of unequal curvatures is obtained by adding the diopters indicated by a spherometer graduated for plano-spherical lenses for each of the two faces. It is the mean of the numbers read if the spherometer is graduated for "bi" lenses. In the case of a meniscus it is the difference of the numbers read on the spherometer which gives the power of the lens.

In accordance with this practice, opticians have taken to the habit of designating the curvature of the surfaces by the numbers of diopters read on a spherometer graduated for plano-spherical lenses; thus a curvature of 6 diopters designates the curvature of a plano-spherical

\* This refers to the three-legged dial-gauge lens-testers (dioptrimeters), rather than a true spherometer. (Trans.)

lens having the power of 6 diopters. That power is  $\frac{1}{f} = \frac{n-1}{R} = \frac{0.527}{R} = 6$ ,  
whence  $R = \frac{0.527}{6} = 0.0878$  metres.

### Frontal Diopters

The focal length of a lens or of an optical system defines the size of the image which that lens or that system gives of an object at infinity. If that object is seen within the angle  $\alpha$  (Fig. 28) the size of its image

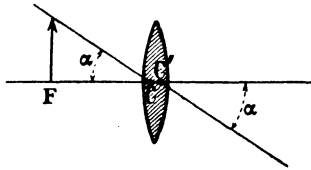

FIG. 28.

is  $f \tan \alpha$ . The dimension  $f$  is measured from the focus  $F$  to a certain point  $C$  called the nodal point, which is only rarely situated on a surface of the lens. The powers which one considers in scientific optics are equal to  $\frac{1}{f}$ , but in spectacle lens optics it has been found more practical to take instead of the true focal length, the distance from the focus  $F$  to the centre of the back surface of the lens. That distance  $FA$  (Fig. 29) is spoken of as the frontal distance, while the focal length

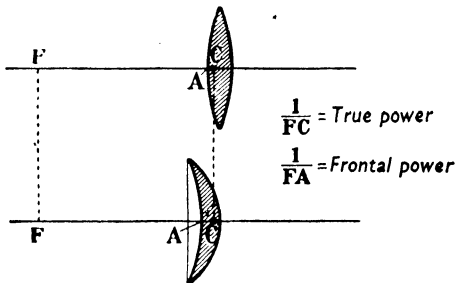

FIG. 29. Lenses of the same true powers and of different frontal powers.

is  $FC$ . There is an increasing tendency to number lenses in "frontal diopters" which are the reciprocals of the frontal distances. For weak lenses the powers expressed in true diopters or in frontal diopters differ very little, but, for strong lenses, the differences can exceed 1 diopter and more in the case of meniscus lenses. Fig. 29 will explain the reason for these differences.

**Cylindrical Diopters**

Cylindrical diopters are the reciprocals of the focal lengths measured in the right sections of the cylinders.

Ophthalmologists indicate on their prescriptions the cylindrical diopters, with the direction of the cylinder axis, and the spherical diopters which the optician has to combine. Corrective lenses may be biconvex (or concave), plano-convex (or concave), periscopic (that

Doctor's Name .....

Prescription  
to be executed for

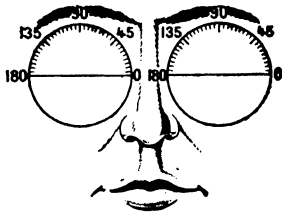

Mr.....

in

Sphero-cylindrical  
meniscus  
toric  
bifocal  
lenses

For cylindrical lenses the oculist marks the directions of the axes on this diagram.

		Axis	Cyl.	Sph.	Prism.	Inter-pupillary distance
Distance Glasses	Right Eye					
	Left Eye					
Reading Glasses	Right Eye	45°	+1.5 <sup>D</sup>	-1 <sup>D</sup>		63 mm.
	Left Eye	135°	+2 <sup>D</sup>	+1.5 <sup>D</sup>		
Music Glasses	Right Eye					
	Left Eye					

Frame: Shell

Date.....19....

is to say, slightly bulging), meniscus or orthoscopic \* (that is to say, more strongly bulging), or special (see the close of this chapter).

The rules to be followed in dispensing the oculist's prescription, that is, for deducing from it the curvatures of glasses of one of the types indicated above, find their place in a spectacle lens-maker's handbook; we will not stop for them in the present work.

The figure on p. 103 reproduces the model medical prescription laid down by the Institut d'Optique théorique et appliquée (Paris).

The oculist indicates, by a diameter which he draws on each lens in the diagram, the direction of the axis for the cylindrical diopters and specifies it in the third column of the form. He strikes out, at the top of the form, the types of lens that he does not adopt.

The glasses whose types are indicated on the form are each the objects of a special paragraph (pp. 106 *et seq.*).

### Measurement of Powers—Spherometers

The frontal powers are measured with a special instrument called a fronto-focometer, but this expensive instrument is not yet widely distributed.

In the most usual practice, the power is not directly measured. The curvatures are measured and from these curvatures the power is deduced by calculation, using the mean index of refraction for spectacle lenses (1.527).

The curvatures are measured with spherometers. Those most usual are little instruments which are pressed on to the lens in order to measure the sag which the surface gives between the bearing points of the spherometer. A central rod, held by a spring, projects more or less, according to whether the curvature is greater or smaller. This rod controls a needle which moves over a dial which is generally graduated in diopters, thus giving directly the power of biconvex or biconcave lenses that have both their faces of the same curvature.

When these spherometers are applied upon a plano-convex or plano-concave lens, the power of the lens is the half of that read on the dial.

When these spherometers are applied upon a lens whose curvatures are different, it is necessary, in order to deduce the power of the lens from the figures indicated by the needle on the dial, to suppose that the lens consists of two plano-concave or plano-convex lenses joined by their plane surfaces. The power of each plano-convex or plano-concave element is measured; the power of the lens is the sum of the powers of these supposed elements, if the curvatures are both concave or both convex; it is their difference if one of the curvatures is convex and the other concave.

\* An orthoscopic lens is usually a combination of a prism with a selected spherical power. (Trans.)

Before using a spherometer it is necessary to make sure that it is in adjustment or, if necessary, to adjust it. The zero must be set by pressing it on a plane surface.

### Approximate Calculation of Radii of Curvature to produce a Power $\phi$ given in Diopters

The calculation is made for a biconvex or biconcave lens and transposed, if necessary, to fit another form of lens.

$$\text{The focal length } f = \frac{1 \text{ metre}}{p}$$

$$\text{The formula for thin lenses gives } f = \frac{R}{2(n-1)} = \frac{1}{p}$$

On replacing  $n$  by its spectacle lens value ( $n = 1.527$ ) one has

$$R = \frac{2 \times 0.527}{p} = \frac{1.054}{p}$$

By a rough but rapid approximation, take  $n = 1.5$  (in place of 1.527):

$$R = \frac{1}{p}$$

The calculation of exact curvatures demands a closer approximation, and the application of fairly complicated formulæ, especially when thick meniscus lenses and frontal diopters are concerned.

### Numbering in Inches

Use is still occasionally made of an earlier numbering system in inches (1 French inch =  $\frac{1 \text{ metre}}{37}$ ).

The number of a lens, of any shape, indicated in inches the length of the radius of curvature of the equivalent biconcave or biconvex lens. With this numbering the foregoing formulæ give for a biconvex lens of 1 diopter:

$$R = 37 \times 1.06 = 39.22 \text{ in. (French).}$$

The conversion of inches into diopters can only be made in an approximate fashion. A table of equivalents which must be consulted when making such a conversion has been drawn up. To a very rough approximation the number in inches corresponds to the quotient

$$\frac{39.22}{\text{number of diopters}}$$

### Prismatic Diopters

Strabismus can be corrected by a prismatic glass. The prismatic diopter is the power of a prism which deviates a visual ray by an angle subtending 1 cm. at 1 metre distance. A prism of  $n$  diopters deviates by  $n$  cm. at a distance of 1 metre. The powers of prisms are also reckoned in degrees of deviation. Here is a table of deviations corresponding to the two notations:

Angle of prism in degrees	Deviation
1°	0° 31'
5°	2° 36' 30"
10°	5° 18'
Prismatic diopters	
1	0° 34' 23"
5	2° 51' 21"
10	5° 42' 38"

These tables show that, for the same numbers, the deviations are a little greater when these numbers represent prismatic diopters than when they represent refracting angles.

The first table shows that, in the case of prisms of small angle, deviation is hardly greater than the semi-angle of the prism.

### VARIOUS USUAL TYPES OF SPECTACLE LENSES

#### “ Bi ” Lenses

For a long time hardly any but “ bi ” lenses, that is to say, biconvex or biconcave lenses of equal curvature, were worn.

The power of a “ bi ” lens is double the power of a plano-concave or plano-convex lens of the same curvature; it can be read directly from a spectacle spherometer specially graduated for “ bi ” lenses.

Bi-lenses have the drawback that they only give clear vision in the neighbourhood of the axis of the lens. To obtain a more extended clear field of view, recourse must be had to “ bulged ” lenses. Plano-convex or plano-concave lenses are a little better than “ bi ” lenses.

#### Periscopic Lenses

Periscopic lenses are still better than plano-concave or plano-convex lenses; they are comparable to plano-concave lenses fixed to plano-convex lenses. The power of a periscopic lens is the algebraic sum of the powers of the two lenses into which it can virtually be resolved.

For economy in manufacture, a common curvature is given to one

face of a whole series of lenses of different powers; this curvature is known as the base curvature. It is generally the curvature which a plano-convex lens of 1 or 3 diopters \* would have. Only the curvature of the other face is changed in order to vary the power.

Whether convergent or divergent lenses are concerned, it is always the weaker curvature which is the base curvature. Thus large blocks can be formed for working the base surfaces.

### Meniscus Lenses

Meniscus lenses are even more bulging than periscopic lenses. Their base curvature is generally that of a plano-convex lens of 6 diopters. They are said to have an exaggerated camber.

Meniscus lenses give a sufficiently extended clear field when their powers lie between  $-6$  and  $+6$  diopters.

### Point Image Lenses

Beyond the limits of  $-6$  or  $+6$  diopters one can have an excellent field by having recourse to special lenses whose two curvatures have been specially calculated for each power. These lenses are called "Stigmal", "Orthal", etc.

These lenses are a little better than the meniscus lenses for low powers, but are very superior to them for strong powers to  $-23^D$  and  $+7^D$ . Beyond  $+7^D$  one cannot obtain a fairly extended sharp field with spherical curvatures. Lenses are made, one of the surfaces of which departs a little from a sphere, to augment the extent of the sharp field; these are expensive lenses known as aspherical lenses.

It is clear that the "bulged" lenses cannot be blocked in such large numbers as can the plano or "bi" lenses. As a result the more "bulged" a lens is, the dearer it is, and the point image lenses, whose two surfaces are specially made for each power, are even higher in price.

### Sphero-cylindrical Lenses

The combination of a spherical face and a cylindrical face yields a sphero-cylindrical lens. In order to correct the astigmatism of an ametropic eye, a lens must be placed before it which has an astigmatic defect equal and opposite to the eye's astigmatism. If the eye is neither myopic nor hypermetropic, but only astigmatic, its defect can be corrected by a cylindrical lens of weak curvature. If the eye is simultaneously myopic or hypermetropic, as is generally the case, the two defects can be corrected by putting a plano-concave or plano-convex lens, to correct the myopia or hypermetropia, together with a plano-cylin-

\* Many so-called periscopic lenses have a base of  $1.25^D$ .

drical lens suitable for correcting the astigmatism. Thus one is led to manufacture sphero-cylindrical lenses.

The spherical and the cylindrical surfaces can be worked as has already been explained. These lenses of weak curvature can be blocked in large numbers.

Each cylindrical lens should bear on its edge a little mark indicating the diameter parallel to the axis of the cylinder. It is easy to mark this axis if the lens is still blocked on the tool which has served for surfacing it. If the lens has not been marked before being "knocked off", the axis of a plano-cylindrical lens can easily be found in the following way. One looks at some parallel lines (joins in the parquet floor, for instance) and places the lens at about 20 cm. from the eye, in such a way that the lines viewed traverse the lens and overlap it. As the lens is turned about its centre, the images of the lines in the lens incline more or less and separate or get closer together. When they coincide exactly with the extremities which overlap the lens, the axis of the cylindrical lens is normal to these lines. When a sphero-cylindrical lens is concerned, the effect of the spherical face superposes itself upon that of the cylindrical face.

Instead of marking the axis, certain opticians, after having suitably orientated the lens in the frame, mark this orientation by a mark with a diamond point at the side of the screw which closes up the frame.

### Toric Lenses

If a myopic or a hypermetropic wishes to profit by the advantages of "bulged" lenses, and at the same time correct his astigmatism; he should adopt toric lenses. These are lenses of which one surface is toric and the other spherical.

A torus is the volume generated by a sphere rotating about an axis which does not pass through its centre (see p. 89). The strongest curvature of a torus is in the planes passing through the axis, that is the curvature of the generating sphere. The weakest curvature is in the plane of its equator, that is to say, in the plane normal to the axis of the torus and passing through the centre of the generating sphere. The toric surfaces of spectacle lenses are small segments of a torus taken astride the equator, and the direction of the plane of the equator corresponds with the axis of the cylindrical lenses. Toric lenses, having two curvatures, have two powers in the planes corresponding to the curvatures.

The makers choose for their collection of toric lenses a typical camber, the same for all lenses, whatever their power may be. This camber is generally 6 diopters, *i.e.* the radius of the equator of the torus is the same as that of a plano-convex lens of 6<sup>D</sup> (this radius is 87.7 mm.). The toric lenses of the collection are said to be to a base of 6 diopters.

In similarity to the cylindrical lenses the direction of the equator is called, in practice, the direction of the axis. The curvature in a section normal to that axis is always stronger than the basic curvature. The difference in power of the lens in the plane of the axis and in the plane normal to the axis, must be equal to the power of the cylindrical lens which should be superposed on a spherical lens to correct the astigmatism of an astigmatic eye.

Let us suppose an eye which is myopic to the extent of 1 diopter with regard to horizontal lines and myopic to  $2\frac{1}{2}$  diopters with regard to vertical lines. It will be given a lens whose convex spherical surface will have 5 diopters, the concave toric surface having 6 diopters along the axis and 7.5 diopters normal to the axis. The tool for working this surface will be marked 1.5 because its transverse power ( $7.5^D$ ) exceeds by  $1.5^D$  the base power ( $6^D$ ). In certain firms this tool will be marked 15, which is to say that it has in a section normal to the axis the curvature of a "bi" lens of  $15^D$  ( $=7.5^D \times 2$ ). Both these methods of marking are used equally. The first directly translates the oculist's prescription, the second has the advantage of allowing rapid identification of a toric lens with a spectacle lens spherometer graduated for "bi" lenses.

*Further examples:—*

For a hypermetropic eye of  $1^D$  in one direction and of  $2.5^D$  in the normal direction are used a concave spherical surface of  $5^D$  and a convex toric surface of  $6^D$  and  $7.5^D$ . This toric surface will be obtained with the convex tool corresponding to the concave tool used in the preceding case.

For a hypermetropic eye of  $0.5^D$  in one direction and myopic to  $1^D$  in the normal direction, two solutions can be obtained.

*First Solution.* Convex spherical surface of  $6.5^D$  and concave toric surface of  $6^D$  and  $7.5^D$  (still obtained with the convex tool indicated above).

*Second Solution.* Convex toric surface of  $6^D$  and  $7.5^D$  and concave spherical surface of  $7^D$ .

The first of these two solutions is preferable, because it uses a slightly less strong spherical curvature.

Each toric lens should bear on its edge, like a cylindrical lens, a little mark parallel to its axis. If the glass has not been marked before having been separated from the tool upon which it was blocked for surfacing its toric face, here is how its axis can easily be found again, that is to say, the direction of a normal to the section of greatest curvature. Each toric lens has two powers, the one corresponding to the strongest curvature, the other corresponding to the weakest. The weaker power is neutralised by putting with the toric lens a spherical lens of the same power as the power to be neutralised but of opposite sign. Thereupon

one operates in the same way with the combination as has been described for the sphero-cylindrical lenses; viewing parallel lines and turning the lenses until the images in the lenses exactly prolong the extremities which overlap.

### Surfacing

The surfacing of spectacle lenses does not demand the optical precision of working to the test plate; mechanical precision is sufficient, but the polish must be perfect.

Hand working would be much too dear; surfacing has, then, to be done on special high production machines. The range of convex and concave tools necessary for all the curvatures corresponding with all the usual powers with all the lens forms being a considerable number, one only employs for the smoothing soft iron tools, less burdensome than brass tools. The work of polishing being, in consequence, more important, one polishes under heavy pressure which prohibits the use of pitch polishers. Polishing on cloth or on felt is, indeed, the only method employed, except for special highly priced lenses. If it does not give irreproachable surfaces, it yields a polish which leaves nothing to be desired.

In Chapter III the processes of surfacing cylindrical and toric surfaces were seen. These lenses cannot be blocked in such large numbers, and in the case of toric lenses of the point image type, they must generally be surfaced one by one.

A good working optician must know how to make, on a pedal lathe, all the spherical spectacle lenses, and, on universal automatic lathes, the cylindrical or toric lenses. Much practice is required, moreover, to surface on a pedal lathe certain bifocal lenses, and it is an excellent exercise.

### Centring and Edging. (See Chapter VIII)

We shall next describe some special lenses which exhibit particular difficulties of manufacture.

### Bifocal Lenses

Many people have need of spectacles of different powers, according to whether they wish to see far off or very near by. Lenses are made whose upper part serves for distant vision and whose lower part serves for near vision. These are bifocal lenses. Trifocal lenses, even, are made.

There are several sorts of bifocal lenses.

(1) *Cemented Bifocals*, which are composed of a half lens stuck on a

complete lens. There is nothing special about their surfacing. For cementing, see Chapter VIII.

(2) *One-pièce Lenses*, whose two surfaces on the one face cut one another along a projecting angle (Fig. 30).

(3) *Lenses called "Uni-bifo"* (single bifocal lenses) (Fig. 31), whose two surfaces on the same face form a slight shoulder.

The first are the least difficult to surface. The only difficulty consists in producing a very sharp line of demarcation without the slightest joining surface which could give indistinct vision and, in any case, spoil the good appearance of the lens. For surfacing each element of the doubly curved face, the mallet is stuck exactly over the part to be surfaced, and the lens is guided on the tool, or the tool on the lens.

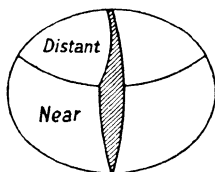

FIG. 30.

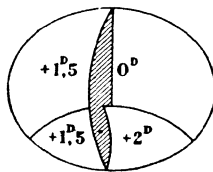

FIG. 31. "Uni-bifo" lens.

whilst very exactly producing the movements and forces proper to avoid the edge-off effects (*i.e.* without rolling or "scouring"), in such a way that neither the lens nor the tool pivots on the boundary edge.

The surfacing of faces which have a shoulder is more delicate. The shoulder describes an arc or a circle on the lens. It is necessary to choose a tool having simultaneously the desired curvature and the terminal circumference of the same radius as the curve of the shoulder. With care and making use of suitable stops placed so as not to "force" against the shoulder, smoothing is done with the edge of the tool only. If the polisher is well made and finishes in a sharply cut edge, the lower part of the surface can be polished right up to the shoulder, but the polish is long in gaining the foot of the ridge. One can hasten this final polishing by making use of a polisher which might be called an "omnibus polisher". It is a tube of brass, of 10 or 15 cm. diameter, on one end of which has been put some pitch covered with a scrap of cloth cut sharply round the circumference of the tool; the pitch is slightly sunk into the interior of the tube. Such a polisher bears on all spheres by the annular surface of the cloth which covers the thickness of the tube. The polisher being mounted on the lathe, one presents the lens to it by pressing the shoulder on the side of the polisher, and following the whole length of the shoulder.

(4) "*Lenticular*" Lenses (Fig. 32) are relatively light lenses although of high power. The active part of the lens is of small diameter, but it is prolonged by a circumference with plane parallel surfaces. They can be surfaced by the same processes as "uni-bifocal" lenses.

(5) *Fused Double Focus Lenses*, commonly designated by the name "Telegic",\* the trade mark of the first lenses of this type placed on the French market, merit special mention, not because a practised optical worker can try to make them himself, but because they show an example of an industrial optical product perfected in a remarkable way.

A lens of this type consists of a large crown glass lens and a "pastiche" of flint glass welded to the crown lens. Each face of the lens presents only a single curvature; the difference of the powers of the

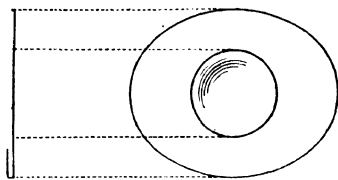

FIG. 32. Lenticular glass.

two regions only lies in the difference of the refractive indices of the two materials and the curvature of their common surface. The crown is, then, worked as a bifocal lens of the first type studied above (*i.e.* with a projecting joining edge). The flint is worked as an ordinary small lens. When the two surfaces to be united are polished and perfectly cleaned, the flint is placed in the lodgment that has been prepared for it in the crown, but with one edge held up by a little metal rod in order that the hot air can circulate between the two lenses, and the whole is put into a furnace. It is not, however, indispensable to place a little rod between the two lenses if suitable precautions are taken to ensure that no air is imprisoned between them.

The flints soften at a lower temperature than the softening point of the crowns. If, then, the furnace is brought to a temperature between that of softening of the crown and that of the flint, the flint softens and sags progressively on the crown, commencing from the edge opposite to the rod, pushing out the air towards the rod. The rod has been chosen of such a material that it volatilises and no trace of it remains. As the crown is quite close to its softening point, the two surfaces weld perfectly and their polish, even, is not altered. It remains to surface

\* Similar products are known in Great Britain as "Kryptok", "Impercepto", "Two-Fo", "Akro", and by various other trade names. (Trans.)

the double lens thus obtained. It will be understood that to succeed, without too many rejects, in such a meticulous manufacture, no detail of the work can be neglected or left to chance. The choice of materials to be married together is particularly delicate. The danger of temperature variations in optical working is known. Here, as enormous variations of temperature are concerned, if the flint or the crown have coefficients of expansion which differ too much, there will be numerous spontaneous ruptures during cooling. The condition of comparable coefficients of expansion is of the first importance. Another condition, generally little realised, is to marry materials having comparable dispersive powers, for the introduction of flint of high dispersion in the combination increases the chromatism of the images. That is to say, the edges of black objects on a light background appear coloured. It is to be hoped that, one day, this fault may be corrected, for there have been for a long time, in catalogues of optical glass, glasses simultaneously more refractive and less dispersive than certain others. The union of these two sorts of glasses constitutes so-called "abnormal" combinations. Perhaps abnormal combinations will be arrived at which will satisfy the conditions of softening and expansion, while giving a sensibly achromatic combination. In order that the possibility could be examined, the catalogues of optical glasses would have to give, for each melt, its softening temperature and its coefficient of expansion.

(6) *Half-moon Glasses.* The lenses called half-moon glasses can be put into the category of bifocal lenses. They are lenses which are suitable for presbyopics; these, not having the need for lenses for seeing a distance, but only for reading or working, can advantageously wear convergent lenses whose upper part has been removed. These are half-moon glasses.

The cut must be very sharp, without chips, and worked nearly to follow a plane or a cone passing through the centre of the eyeball, in order that the cut shall be as little visible, and consequently as little inconvenient, as possible. The surface of the cut edge should be unpolished in order that only diffused light passes to the eye, so that flashes of light are avoided.

(7) *Franklin Lenses.* By placing two half-moon lenses of different powers in juxtaposition so as to form, as it were, a complete moon, one obtains a bifocal known as a Franklin lens. The component half-moons are held together by the pressure of their frames only. Franklin glasses are the easiest bifocal lenses to make.\*

\* They are said to suffer from a tendency to spring out of their frames with a slight shock. (Trans.)

## PART TWO—FOR THE USE OF WORKS MANAGERS AND SENIOR WORKMEN

---

### CHAPTER V

#### THE MECHANICAL THEORY OF THE WORKING OF OPTICAL SURFACES

##### PLANE SURFACES

###### **Translatory and Rotary Movements**

Simple translation is a displacement of an object parallel to itself. There is simultaneous translation and rotation when an object is displaced while changing its orientation. The hand which turns a coffee mill describes a circle, but its movement is one of translation, because the finger always remains in the same position (or very nearly). It is said that there is circular translation. The wooden horse of a roundabout turns with the whole roundabout around its common axis; but it can also be considered as being animated on the one hand by the same circular translation as that of the hand on the coffee mill—a translation which entrains the vertical axis supporting the horse—and on the other hand, by a rotation around that axis of the same period as the circular translation, because at each revolution its rider sees the whole horizon pass before him exactly as if he were on the actual axis of the roundabout and connected to it. The lens which is allowed to rest on the disc of a lathe is animated by the same dual movement as the wooden horse; a circular translatory movement carrying along one of its points and a rotary movement of the same period around that point. If one opposes one of these component movements the other remains. Thus if one holds the lens carrier in place by means of the ball pointed finger of an automatic machine one suppresses the translatory movement of the lens, but leaves it at liberty to turn about its own axis, and it continues to rotate in a fixed position with the same cadence (so many turns per minute) as the disc on the lathe.

The workman who works a plane by hand, holding a screwed knob, produces movement of translation only. If he works by the aid of a ball pointed handle, or if his glass is guided by an automatic machine

the rotary movement is produced at the same time as the translatory movement.

Before going any further it is necessary to familiarise oneself with these fundamental mechanical notions and to convince oneself that the natural movement of a body which one endeavours to displace around another by pushing on its centre, is a simple translation, that is to say, without rotation about itself. A simple experiment proves this.

On a horizontal disc (Fig. 33) let us fix a vertical axis at some point *A*. On this axis let us mount a fairly heavy disc, capable of turning very freely on its axis, for instance by the help of a ball bearing.

Let us give the plate a sharp rotary movement; the little axle is displaced in a circle, carrying the disc in a circular movement, but the

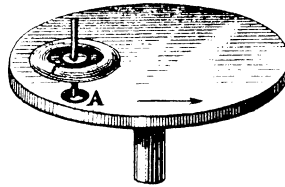

FIG. 33.

disc, so long at least as the friction of the ball bearing does not intervene to any appreciable extent, does not turn with respect to us. An arrow *f* which it carries, remains pointing to the right during the whole revolution. In order that the arrow should remain parallel to an arrow marked on the plate, it would be necessary to impress on the disc a rotation about its own axis equal to the rotation of the plate. Without the intervention of a supplementary force the disc has only a simple circular translation.

If the plate continues to turn, the friction of the little axle, or of the balls, although feeble, little by little drags the disc which itself commences to turn, although very slowly. As the experiment is prolonged the speed of rotation of the disc approaches that of the plate.

If, now, the plate is arrested suddenly the disc continues to rotate in its place with the same speed as formerly. A new force will be necessary to stop its rotation just as it required a special force to commence it.

If before the plate is arrested the disc turns about its axis at the same speed as the plate it could be believed to be welded to the plate. That is why it can be said that a glass placed on a revolving flat tool and a little to one side is simultaneously animated by two movements, first a circular translation and second a rotation about its own axis

at the angular velocity of the flat tool. If one of the two movements is suppressed the other tends to persist. Naturally, greater force is required to oppose the two movements at once than to oppose one only. Indeed it is observed that to hold a lens on a rotating tool by a screwed knob needs a greater force than to hold it with a rotating handle, especially if the lens is nearly centred with the flat tool. In the first case a translation and a rotation are destroyed simultaneously; in the second only a translation is destroyed.

### Instantaneous Centre of Rotation

When a body turns about a centre, each point on that body is displaced in a direction normal to the radius from that point to the centre and with a velocity proportional to the length of that radius. But

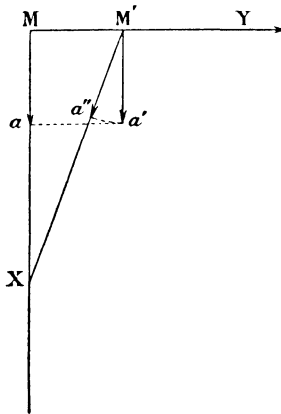

FIG. 34.

rotation about a fixed centre is only a particular instance. The most general movement of a disc which is displaced on a stationary plate, guiding it by a central knob, is a translation of speed  $V$  accompanied by a rotation of an angular velocity  $\gamma$  around the handle or the pin socket. If at a given instant the knob is at  $M$  (Fig. 34) and moving in the direction  $MY$  it can be considered that the point  $M$  turns around a point situated on the normal  $MX$  to the direction of displacement. Let us mark on the disc an arrow  $Ma$  in the direction  $MX$ . At the end of a very short time  $t$ , if the disc does not itself turn, the arrow  $Ma$  arrives at  $M'a'$  parallel to its first position, the displacement  $MM'$  being equal to  $Vt$ . But, as the disc turns, the arrow  $Ma$  during the same time  $t$  takes up the position  $M'a''$  such that the angle  $a'M'a''$  will equal  $\gamma t$ .  $Ma$  and  $M'a''$  can be constructed since  $V$  and  $\gamma$  are known. The intersection  $X$  of these two lines is evidently the only

point connected with the disc which will rest immobile during the time  $t$ . It is the instantaneous centre of rotation for the instant considered. The distance  $MX$  is equal to  $\frac{V}{\gamma}$ . At another instant, the displacements having changed direction, one usually observes that the instantaneous centre is no longer in the same place, from which comes its name of instantaneous centre which signifies that it is only the centre of rotation during an infinitely short period.

The geometrical construction, like the formula  $MX = \frac{V}{\gamma}$ , shows

that, if only the translation existed, that is to say, if the rotation were nil, the distance  $MX$  would be infinite, the instantaneous centre would be at infinity. To move the instantaneous centre away, either the speed  $V$  must be increased or  $\gamma$  be diminished, or both modifications be made at once. Now there is always a strong reason to keep the instantaneous centre as remote as possible, for so long as it is far removed its situation is of the very greatest importance from the point of view of uniformity of grinding.

It is useful to understand the reality of the instantaneous centres of rotation through some concrete examples. Everyone has manipulated, or at least seen, an instrument or machine carriage displaced along a rack by means of a pinion turned by a hand wheel. When the hand wheel is turned clockwise, it advances to the right while turning on its own axis. The top of the hand wheel is displaced towards the right, as is the carriage, but faster than the latter. The bottom of the hand wheel, on the contrary, is displaced towards the left. Between the top and bottom of the hand wheel there is a point which, during a very short time, is displaced neither to right nor to left. That is the instantaneous centre of rotation of the hand wheel at the chosen instant. It is opposite to the tooth of the rack which is in engagement with the pinion controlled by the hand wheel. This pinion rolls on the rack as a carriage wheel rolls on the ground. The point at which the wheel is in contact with the ground is the instantaneous centre of rotation of the wheel, its velocity is zero, while the velocity of a point taken at the top of a wheel is twice that of the axle. The geometric locus of the instantaneous centres of rotation is the track upon which the wheel rolls.

#### **Influence of the Position of the Instantaneous Axis of Rotation on the Distribution of Wear**

When a disc is displaced while turning on a fixed plate, its movement is a rolling movement on a virtual curve which can be imagined to be traced on the prolonged plate, and which is the locus of the instan-

taneous centres of rotation of the disc on the plate. It is the same if the disc is displaced on a plate which is rotating faster or slower than the disc. When the difference of the two velocities is large the curve of rolling is small; when the difference of velocities diminishes the curve of rolling increases. It becomes infinite when the two speeds are equal.

From the point of view of uniformity of wear of the disc, its distance from the instantaneous centre of rotation on the flat tool has a preponderant influence. Effectively, at each point of the disc, the wear

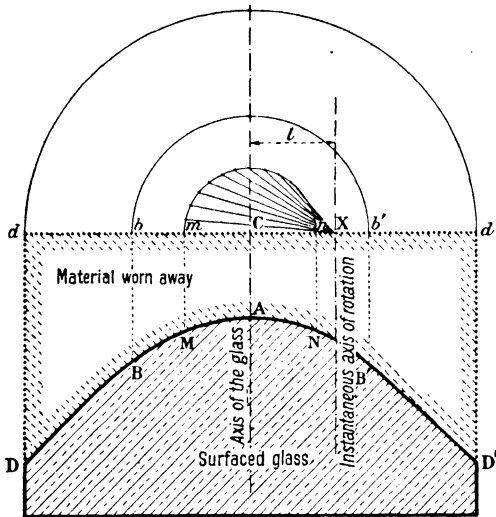

FIG. 35.

during an instant is proportional to the speed of rubbing and consequently to the distance from the instantaneous centre. When that centre is displaced around the disc, the wear of a ring of the disc is, in the long run, proportional to the mean distance from the instantaneous centre to all points on the ring. In the upper part of Fig. 35 the distances from the instantaneous centre  $X$  to fourteen equidistant points on a thin half ring  $mn$  of the disc are traced. The wear on this ring is proportional to the mean of these distances.

If the instantaneous centre  $X$  is supposed to be turning around the disc while remaining at a constant distance  $l$  from the centre of the disc, Fig. 35 shows in section (hatched part) the distribution of the wear from the centre to the edge, the wear at the centre  $A$  being measured by  $AC = l$ . If the wear of the centre is compared to the wear upon a ring  $MN$  whose radius  $r$  is a fraction  $p$  of  $l$  ( $r = pl$ ), it

is seen that the excess of wear on the ring is smaller in proportion as  $p$  is small. The excess of wear annuls itself when  $l$  is infinitely large in relation to the ring under consideration. If, on the contrary, the instantaneous centre is inside the ring ( $p > l$ ), the excess of wear on the ring becomes considerable.

When the instantaneous centre is quite close to the centre of the glass, the glass wears conically, that is to say, the wear on a ring of radius  $r$  is proportional to  $r$ . From this the course of the curve is that of an hyperbola. The ordinates of the curve of wear (Fig. 35) have been chosen in such a way that the hyperbola will be equilateral (rectangular asymptotes).

According to these conventions the ratio of the wear  $K = \frac{Mm}{AC}$  measured on the figure as a function of the distance  $l$  from the instantaneous centre is given approximately by the formula

$$K = \sqrt{1 + \frac{r^2}{l^2}} \quad \text{or} \quad = \sqrt{1 + p^2}.$$

The coefficient  $K$  can be called the "coefficient of braking", since it is by this number that the wear at the centre of the glass must be multiplied to obtain the wear on the selected ring of the glass by a braking effect which alters the equality of the rotation of the discs (without taking into account the overlap or the contingent inequality of pressure).

### Variations of the Positions of the Instantaneous Centre of Rotation with the Overlap

Let us consider two plates, supposed first to be externally tangential (*i.e.* touching by one edge), the upper plate, with centre  $C$ , held by a central pivot pin and the other, with centre  $O$ , mounted on the axis of the lathe. If the plate  $O$  turns, the other turns in a contrary direction, as if the two plates were provided with gear teeth on their circumferences. The instantaneous centre is at the point of contact. If the upper plate encroaches upon that which is mounted upon the lathe its rotation slows down and the ratio of the imaginary gears  $OX/OC$  diminishes. For a certain position the upper plate ceases to turn; at that moment the ratio  $OX/OC$  becomes zero and the instantaneous centre is on the axis of the lathe. If the axis of the upper plate still approaches the lathe axis the upper plate commences turning slowly in the same direction as the lower plate and its speed of rotation tends to equal that of the lower plate in proportion as the distance between the axes of the plates diminishes.

Equality of rotational speeds is attained:

1st. If the upper plate is the smaller, as soon as it no longer overlaps the lower.

2nd. If the upper plate is the larger, when it becomes concentric with the other.

The instantaneous centre is then removed to infinity.

The three centres align themselves in the sequence  $X, O, C$  when the two plates turn in the same direction. They present themselves in the order  $O, X, C$ , if the plates turn in contrary directions.

One can consider, indifferently, that the plate  $O$  rolls on the plate  $C$  or inversely, since relative motion only is concerned. The instantaneous centre  $X$  is, then, the same for both plates.

The normal disposition of the three centres  $X, O, C$ , favours the position of the lens or block to be surfaced on the tool. If the lens is borne by the plate  $C$ , its instantaneous centre is a little further away than if the lens is borne by the plate  $O$  mounted on the lathe; the difference of these two distances is equal to the eccentricity of the two plates.

Moreover, one is master of maintaining the instantaneous centre at the distance that one desires by employing a surfacing machine equipped with means of imposing a desired speed of rotation on the upper plate.

### Systems of Surfacing

The different systems of surfacing may be put into five classes.

*First Class.* The system of translation only, on a fixed tool post, is a system of even wear, on condition, only, that the pressures shall be

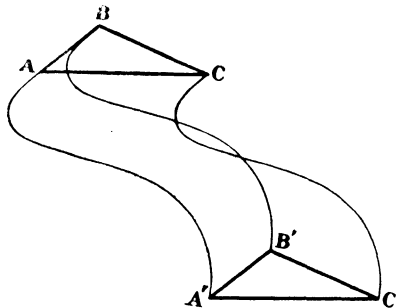

FIG. 36.

uniformly distributed over the surface of the glass and that one works, without overlapping, on a tool larger than the glass.

If one chooses on the moving body several points, for example, the points  $A, B, C$ , the straight lines  $AB, BC$ , and  $CA$  are displaced parallel

to themselves and the straight paths, or curves, which the points  $A$ ,  $B$ , and  $C$  describe in passing to occupy another position  $A'$ ,  $B'$ ,  $C'$ , will obviously be parallel and equal (Fig. 36). The moving body is thus ground equally at all points.

*Second Class.* *The system of rotation of the tool only—the glass being fixed*—produces a wear at each point proportional to the distance of that point from the centre of the tool, so long, at least, as the progress of that wear is not opposed to the admitted hypotheses of uniform distribution of pressures over the surface of the glass. A glass submitted to this system will become convex and conical, the axis of the cone being merged with the axis of the lathe. If the glass turned about its axis without being displaced, it would still be conical but the axis of the cone would be on the axis of the glass.

*Third Class.* *The system of translation alone on a rotating tool*, is a system of uneven wear. This is the system of treadle or hand lathes. Obviously nothing is altered in the system of grinding if the machine, including the tool and the glass, is supposed in addition to be given a rotary movement about its axis equal to and opposite in direction to the rotation of the lathe. On this hypothesis the tool, supposed to be animated by two equal and contrary rotations, is completely at rest with respect to the workshop, while the glass which already had a translatory movement has acquired in addition, by hypothesis, a rotary movement. Its translatory movement would produce an even wear, but its rotary movement about its axis brings the instantaneous centre of rotation (which otherwise would be at infinity) closer to it. The regions of the glass near to that centre are rubbed less quickly than the regions further away, which are, in consequence, ground more rapidly than the others.

*Fourth Class.* *The system of free rotation on a rotating tool* is a system of even wear when the glass, resting on the tool, does not overlap it.

Let us consider a glass resting on a rotating flat tool, adhering to it and dragged, with it in its rotation without overlapping it. By pressing on a rotary handle well centred on the glass no couple is introduced; one cannot, then, modify its rotation but only give it a translatory movement. Let us immobilise this rotary handle, that is to say, animate it, with reference to the rotating flat tool, with a circular translatory movement equal to the rotation of the flat tool but contrary in direction. This additional translation will have the effect of suppressing the circular displacement of the glass without introducing any rotation. The glass then will only be animated by the rotation which it already possessed; that is to say, a rotation equal to that of the flat tool and in the same direction. Such is the movement of a glass held stationary on a rotating flat tool by a rotary pin working in a central socket.

Let us suppose the machine to be given a rotary movement on its own axis in a contrary direction to the rotary movement of its axle, as in the third case. Simultaneously the absolute rotation of the tool and that of the glass will be arrested, but the glass will have taken a circular translatory movement; now it has been seen that a simple translatory movement gives a system of even wear.

If the glass, instead of turning on its own axis *to the right* at the speed of the lathe, turned more slowly, the same reasoning would show that this system of wear was equivalent to a circular translation combined with a rotation *to the left*. If the glass had a speed of rotation to the right greater than that of the lathe, the equivalent system would be a translation combined with a rotation to the right. These additional rotations would have angular velocities equal to the differences in rotation of the lathe and of the glass and would increase the wear towards the edges. Thus the same effect is produced either by braking or by augmenting the speed of rotation of the glass by any means whatever.

*Fifth Class.* The system of translation with free rotation on a rotating tool is a system of even wear so long as the glass does not overlap the tool. It is the system of automatic machines.

This system only differs from the preceding one in the addition of a translation. Now by adding one translation to another, one can only produce a translation. The resultant translation is also a system of equal wear.

In all that precedes, it has been supposed that the glass does not overlap the tool. From the moment that the glass does overlap the system is altered.

When the glass overlaps the tool (or vice versa), on an automatic machine the absolute velocity of rotation of the glass (or the tool) is decreased by a small amount  $\gamma$  (see Fig. 34), that is to say, that the glass turns, with respect to the tool, with a velocity  $\gamma$  in a contrary direction to that of the tool; it results from this that the instantaneous centre  $X$ , which was at infinity, approaches closer to the glass proportionately as the overlapping increases.

### **Influence of Overlapping on the Homogeneity of the Abrasive Paste**

It is known that to work well with a wet abrasive, it is necessary to work in such a way that the whole layer of abrasive retains the same consistency and, in consequence, that it is about equally exposed all over. In order to realise that condition easily, a simple means employed on tools working large glasses consists in piercing here and there on the tool, feeding-holes through which are introduced from time to time, drop by drop, a little water, pure or mixed with the abrasive

When the tool is not pierced with holes, or when working with the glass uppermost, this artifice is impossible; it is necessary to regulate the relative movements of the glass and the tool in such a way that the parts of the glass which are never exposed to the air shall be swept by the parts of the tool which have just been aerated. The solution of the problem thus posed is given by a simple and rigorous rule.

Let  $O$  be the centre of the tool of radius  $R$  (Fig. 37).

$C$ , the centre of the glass of radius  $r$  in its most decentred position.

$d$  the overlap.

The circle of radius  $OA$  on the tool is never exposed to the air. The part of the glass which never passes out of the circle  $AA'$  of radius  $OA$

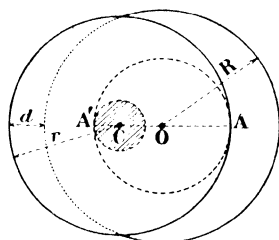

FIG. 37.

is then solely swept by a region of the tool which never sees the air; this part should be nil because it is never uncovered itself. The part concerned is the central region of the glass tangential to the circle  $AA'$  and of radius  $CA'$ ; it is the small shaded circle. It is reduced to a point when the point  $O$  becomes the centre of the distance  $CA$ .

Then  $OC$  should be  $\geq \frac{r}{2}$ ;

now

$$OC + r = R + d.$$

Then

$$R - r + d \geq \frac{r}{2},$$

$$d \geq \frac{3}{2}r - R.$$

This condition being fulfilled, all the regions of the glass receive, by mixing, some abrasive paste which has been exposed to the air. There is no region which only receives the wet paste coming from a central region of the tool which is never uncovered. In its turn, the glass brings back the paste to the part of the tool which is never uncovered, but this part of the tool can only receive this exchange paste, at second hand (so to speak). It would be better if there were no privileged parts even on the tool. Fig. 38 shows that the shaded part

around the centre of the tool only exchanges its paste with the part of the glass which is never uncovered. Let us seek the condition under which this shaded zone vanishes. It is necessary that

$$OC \geq CB = r - d,$$

but

$$OC + r = R + d;$$

from these two relations the condition is obtained

$$d \geq r - \frac{R}{2}.$$

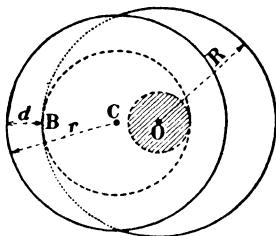

FIG. 38.

In the following, for three values of the ratio  $\frac{R}{r}$ , are the overlaps corresponding to the best mixture of the abrasive paste.

Value of $\frac{R}{r}$	Minimum overlap for the best mixture of the abrasive paste on		
	the glass: $d \geq \frac{3}{2}r - R$	the tool and the glass: $d \geq r - \frac{R}{2}$	
1	$\frac{R}{2} = \frac{r}{2}$	$\frac{R}{2} = \frac{r}{2}$	From the point of view of uniformity of wear of the glass these overlaps are a little large.
4/3	$\frac{R}{8} = \frac{r}{6}$	$\frac{R}{4} = \frac{r}{3}$	
3/2	0	$\frac{R}{6} = \frac{r}{4}$	
2	—	0	

Thus for trueing-up two equal plane tools it is necessary to overlap to at least  $\frac{1}{2}$  of their radius, but, the speed of rotation being greatly slowed down as a result, the wear towards the edges will be rather large. For working a glass of a diameter equal to  $\frac{2}{3}$  of the diameter of the flat tool it is not necessary to overlap but the tool wears a little unevenly. If the diameter of the glass is one half of that of the tool, the wet paste can be very well mixed all over without overlap.

Finally, the overlap, by permitting ample displacements of the glass on the tool, facilitates obtaining a surface free from the small irregularities which the tool can present. If all parts of the glass rubbed successively on all parts of the tool a circular depression on the tool would not reproduce itself on the glass. On the other hand, it would reproduce itself if the oscillation was shorter than the width of the circular depression. In practice one cannot push the centre of the glass right to the edge of the tool, and there is a privileged zone on the tool which never rubs on the central part of the glass. It is useful, from this point of view, to reduce this privileged region as far as possible by a considerable overlapping. Conversely, if the track described by the centre of the glass does not pass over the centre of the tool, there is, around that centre, a central region still having the privilege of never rubbing the centre of the glass. It would be easy to avoid that second privileged region by making the track pass over the axis of the lathe, but, for other reasons, it has been seen that this is not to be recommended.

On machines with alternating motions, if the oscillation is adjusted symmetrically in relation to the centre, the paste is well mixed, but the points at which the track repasses, being at equal distances from the edges, form there a privileged region. It is necessary to work so that the points at which the track repasses are at sufficiently different distances.

It is better to describe a looped track rather than an arc of a circle by reciprocating movements. It is still better to describe the track in little loops as in waltzing, the track is then shaded off; on the other hand, the path followed being longer, the work of translation increases and we have seen that this produces a more regular wear than that produced by the work of rotation.

These conditions of mixing of the wet paste so that it is constantly, and throughout, of a comparable consistency imply, as has just been seen, the necessity of observing certain amplitudes of movement. This necessity does not exist in polishing on paper and that is one of the advantages of this mode of polishing.

### Induced Rotation

Let us now examine the mechanism by which the tool communicates a rotation about its own axis to the glass.

Let  $O$  be the centre of the flat tool (Fig. 39), and  $C$  the centre of the glass and the driving pin.

Let us suppose the glass to be immobilised, it rubs on the flat tool and otherwise is prevented from turning; all the points of the glass in contact with the rotating tool are seats of forces of rubbing, which according to the position which the points occupy, considered in relation to the driving pin, tend to make the glass rotate in one direction or another around that driving pin. At each point the rubbing force

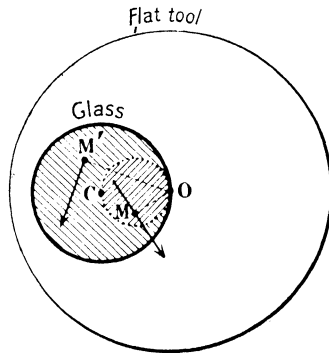

FIG. 39.

is perpendicular to the direction of the instantaneous centre of rotation of the glass in relation to the tool, which point, if the glass is prevented from turning, is the centre of the flat tool itself (the point at which the relative slip is annulled). The points  $M$  and  $M'$  in the figure are such that the force applied at  $M$  tends to cause the glass to turn to the right and the force applied at  $M'$  tends to make it turn to the left. There are, then, two distinct zones on the glass, one the friction of the flat tool on which tends to make it turn to the right, the other the friction on which tends to make it turn to the left. The limit of these two zones is evidently the geometric locus of the points  $M$  for which the normal to the radius  $OM$  passes through the point  $C$ . This locus is the circumference constructed with  $OC$  as diameter.

As for the amount of the frictional force, it is the same at all points on the glass for the same extent of surface element considered around that point, because the frictional forces are independent of the speed of rubbing (Coulomb's law).

In Fig. 39, the zone of friction tending to make the glass turn to the

left is small in relation to the other. It would diminish further if the point  $C$  came nearer to the point  $O$ . That is why more force is needed to stop the glass from turning when it is nearly centred on the tool than when it is more eccentric.

If now we leave the glass free, or partly free, to obey these forces, it will turn around the driving pin. It will automatically take up a system of grinding, and that, considered as rotation relative to the flat tool, will be defined by a centre of relative rotation and by an angular velocity of relative rotation.

We have supposed that the glass does not overlap the flat tool. When it overlaps, the rubbing zone tending to make it turn to the right will have a crescent cut off it. Fig. 40 shows the two rubbing zones of contrary effect differently shaded. It is conceivable that, if the overlap increases, the two shaded circles tend to become equal; there is a moment at which the glass, equally induced to rotate in both directions, comes to a stop. If the overlap is increased still more the effect of the zone contained in the circle  $OC$  surpasses that of the other and the glass begins to turn to the left. Thus, from the moment that the overlap commences, the automatic velocity of rotation of the glass slows down, then annuls itself at a certain overlap and changes direction for a greater overlap.

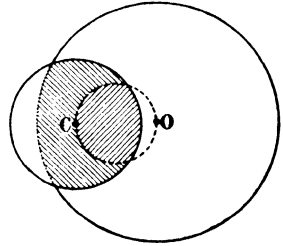

FIG. 40.

If the rotation of the glass is braked, without its being stopped, the instantaneous centre instead of coinciding with the point  $O$  (case of an immobile glass) is at a point  $X$ , further off. The circle constructed on  $CO$  as diameter must be replaced by a circle constructed on  $CX$  as diameter (Fig. 41). When the glass is quite free to turn about a central driving pin the system of wear which establishes itself is, in relative movement, a translation (*i.e.* in absolute movement, the angular velocity of rotation of the glass is equalised with that of the flat tool). This is understood if we think of the case, equivalent from the relative point of view, of a fixed tool and of a glass caused to slide on that tool by the action of a force exerted upon its centre. Such a glass slides with a translatory movement without turning. Consequently the distance  $CX$  becomes infinite and the

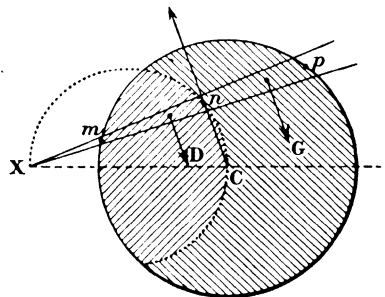

FIG. 41.

circle constructed on  $CX$  as a diameter reduces itself to a diameter of the glass perpendicular to  $CO$ . All the elementary frictional forces then being equal and parallel are in equilibrium with the reaction of the driving pin.

The angular velocity of rotation of the glass being then equal to that of the tool, we designate this system of relative translation under the name of "system of equal rotations". It has the essential property of producing a uniform wear and so it is a system of even wear.

### FUNDAMENTAL THEOREM

**The system of equal rotations is the only one which can be adopted by a small disc held by a central driving pin on a larger flat tool which it does not overlap.**

The intuitive reasoning which we have just made, in referring the case to that of an immobile tool, has allowed us to predict this result. We shall now analyse more closely what takes place.

Let  $C$  be the centre of a little disc placed on a flat tool, not represented, screwed on the lathe spindle (Fig. 41). Let us suppose that the instantaneous centre of relative rotation is at  $X$  on the tool instead of being at infinity. Let us trace, on  $CX$  as diameter, the circumference of a circle which separates the disc into two zones such that the rubbing on the left-hand zone tends to turn the disc to the right, while the rubbing on the other zone tends to make it turn to the left. All the rubbing forces must balance the force  $F$  borne by the driving pin which is at  $C$ . Through the point  $X$  let us trace a very narrow sector which cuts out, in the first zone, the narrow band  $mn$ , and in the second zone the slightly less narrow band  $np$ . The point  $n$  is in the middle of  $mp$  because the angle  $XnC$  is a right angle. The resultant of the rubbing forces on  $mn$  which tends to make the glass turn to the right, is balanced by the force  $D$ . The resultant of the rubbing forces on  $np$  which tends to make the glass turn to the left is balanced by the force  $G$ . The two bands have the same length, but the surface of the second, which is less narrow, is greater. The force  $G$  is, then, greater than the force  $D$ ; on the other hand, the force  $G$  passes further from the point  $C$  than the force  $D$ , as the points of application of the forces  $G$  and  $D$  are not at the middle of the bands but a little closer to the thick end of each band than to its small end. Thus the two components of the moment of the force  $G$  with respect to the point  $C$  are greater than the two components of the moment of the force  $D$ . This inequality exists when the sector sweeps the whole glass in turning about  $X$ ; the forces  $D$  and  $G$  cannot be balanced by a force applied at  $C$ . There

is no equilibrium unless the point  $X$  is at infinity or the glass overlaps the tool.

If the glass overlaps the tool, the crescent which overlaps and which does no work can re-establish the equilibrium between the resultant of the forces  $D$  and that of the forces  $G$ .

The position of the relative instantaneous centre can be approximately computed, in any given case, by tracing on the glass an arc of a circle passing through the point  $C$  and dividing, by eye, the surface rubbed into two closely equivalent zones, the zone situated at the side of the axis of the lathe being hardly greater than the other. At the point where this arc of a circle passes out of the glass, a tangent

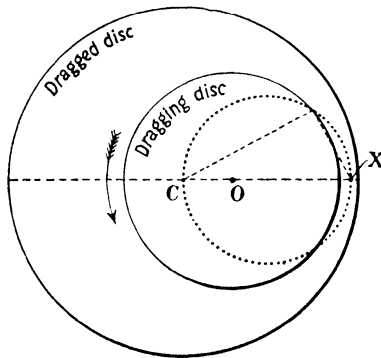

FIG. 42.

to the disc is drawn meeting the line of centres in the point  $X$ . This computation is practically precise enough in most cases, for the distance of the instantaneous centre varies little when this point approaches the disc.

Fig. 42 shows the case of a large flat tool  $C$  pulled round by a small plate  $O$  which does not overlap it. Its instantaneous centre  $X$  is very close, so long as there is no overlap.\*

Fig. 43 shows the case of a small plate  $C$  dragged round by a large

\* When the plate  $C$  is eccentric by  $\frac{1}{3}$  of the radius of the plate  $O$  its instantaneous centre is exactly on the edge of the plate  $O$ , if one takes no account of the effect of out-of-plumbness.

This can be demonstrated easily by the reasoning applied to Fig. 41. In that case, the band  $mn$  reduces itself to a triangle and the band  $np$  can be resolved into two triangles separated by a diagonal. Knowing the ratios of the surfaces of these three triangles, the positions of their centres of gravity, and that the frictional faces proportional to the surfaces of the triangles are applied at the centres of gravity and are parallel to  $nC$ , it is seen that the moment of the force  $D$  exactly balances the moments of two forces which are applied to the band  $np$  and the sum of which equals the moment of the force  $G$  of Fig. 41.

plate  $O$ . Its instantaneous centre  $X$  is much further off than in the case of Fig. 42 since the small disc overlaps.

In both cases the three points  $C$ ,  $O$ ,  $X$ , occur in the same order, that

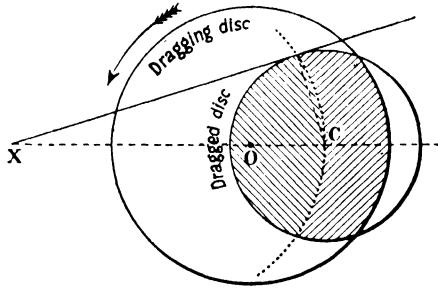

FIG. 43.

is to say, the centre of the driving disc is in between the centre of the driven disc and the instantaneous centre.

## SECOND THEOREM

**When the Upper Plate is larger than the Lower Plate there can be no System of Equal Wear either for the one or for the other.**

It has been seen that the driven plate is divided into two zones by a circumference constructed on the straight line which joins its instantaneous centre of rotation to its geometric centre. One of these zones is induced to turn to the right by the frictional forces and the other is induced to turn to the left. When the instantaneous centre is at infinity the line of separation of the two zones becomes a diameter of the driven disc and both discs are given speeds of rotation which are equal in the case to which the fundamental theorem applies.

But when the large disc rests on the small driving disc, if the two zones of friction are separated by a diameter, these zones instead of being two semicircles of the driven disc would be the two unequal, shaded segments of the driving disc (Fig. 44). There could not be equilibrium between the parallel forces of friction (because  $X$  is supposed to be at infinity) of these unequal segments. The line of separation of the two zones must, then, be an arc of a circle, such as  $ACB$ , passing through the point  $X$ . The instantaneous centre  $X$  being, then, at a finite distance, the angular velocity of rotation of the driven disc is less than that of the driving disc. There is, then, no system of equal wear for it.

As for the driving disc it behaves in relation to the large disc as a small plate turning faster than a large plate on which it rests without

overlapping. It is known that, in this case, the wear on the small disc increases from the centre to the edge, as if it turned more slowly than the large plate.

From the foregoing, it results that it is generally regrettable to place the larger disc on top. This disposition is worse for the small disc than for the large one. In effect the parts of the large plate which are rubbed, wear more in proportion as they are further from the centre; on the other hand, the regions farthest from the centre are worked for the shortest time, which compensates the previous effect. On the contrary, for the lower plate, which is completely covered, there is no compensation. For the double reason that it is animated with a rota-

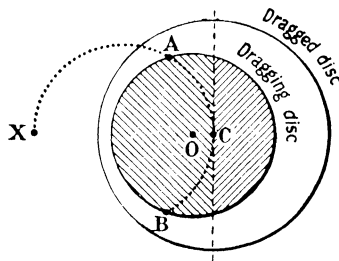

FIG. 44.

tion relative to the other plate, and that it suffers the tilt of the large plate, it tends to become convex. One should not, then, place the surface to be worked underneath when it is smaller than the tool, but it is permissible to work a larger block on top of a slightly smaller tool.

From the preceding considerations, it must be concluded also that there is always an advantage in working a glass as close as possible to the edge of the tool. Indeed, if the glass is free to turn around a central driving pin, all points wear as much as the centre, but as the wear on the centre is proportional to its distance from the axis of the tool, the work progresses more quickly when that distance is greater. If the glass is held by a central handle which prevents it from turning, its relative rotation  $\gamma$  with respect to the tool is independent of the distance from the axis of the tool, while the relative velocity  $V$  of the centre of the glass is proportional to that distance from the axis of the tool. Then, by holding the glass far from the axis of the tool, the excess of wear towards the edges with respect to the wear on the central region is diminished. This can be translated into workshop language as the following recommendation. One should always try to grind the glass more by translation than by rotation, it being understood that there is no wear by translation distinct from wear by rota-

tion; for the wear at a point on the glass is proportional to the path traversed by that point on the tool and this path depends on the geometric sum (not the algebraic sum) of the component velocities.

It has been seen that if the glass turns upon itself at the speed of the lathe, it will be worn evenly all over, and that, by retarding or increasing its rotation the wear towards the edges will be increased. But, when the glass overlaps, the speed of automatic rotation diminishes, thus the part which rubs on the tool wears more away from the centre than it does in the middle. As the part which overlaps does not wear at all there is a sort of compensation between the two effects for the overlapping part. It is clear that, to obtain a nearly complete compensation it is necessary to overlap much more in working with a screwed handle (because the rotation is strongly retarded) than in working with a rotary handle or on an automatic lathe, since the decrease of speed of rotation of the glass is then very slight. As for the part which does not overlap, the slowing down of the rotation must make it convex.

As has been seen on p. 67, the overlapping only causes a reduction of speed of rotation of the upper piece so long as the abrasive is kept carefully in the same state of humidity by the addition of some drops of water, as desired, on the uncovered zone. If moistening is delayed the abrasive dries more quickly on the zone than on the central part which is never exposed to the air and becomes more adherent on the zone than in the central part. The driving disc then acts more strongly on its zone and acts a little like a toothed wheel towards the driven disc. As a result, the speed of rotation of the driven disc increases with the eccentricity. If the driven disc is smaller than the driving disc, its speed can increase by about 20 per cent. before the plate overlaps and still more when it does overlap. Thus a plate of 220 mm. diameter overlapping a plate of 255 mm. rotating at 34 revolutions per minute by one quarter of its radius, assumes a speed of 28 revolutions per minute when the abrasive is well lubricated, and its speed increases to 35 revolutions per minute when the abrasive starts to dry up. The worked surface will thus spoil for two reasons: the inequality of the adhesion of the abrasive and the abnormal speed of the driven disc, which tends to become conical.

To sum up, when a plane glass is surfaced, there are two systems of even wear. First, work upon a fixed post without overlapping. Second, work upon a pedal lathe, using a rotating tool handle, or upon an automatic lathe, without overlap or with slight overlap.

In hand working upon a lathe with a screwed handle, the overlap must be graduated carefully to compensate for the too rapid progression of the wear from the centre to the edge. This progression is as much more rapid as the glass is closer to the centre of the tool.

On an automatic lathe the acceleration of the rotation of the glass would be of no interest. Retardation of the rotation would make the wear increase from the middle towards the edge.

### DEVELOPMENT OF A PROJECT FOR SURFACING SLIGHTLY CURVED GLASSES

#### Calculation of the Distribution of the Wear

When manufacture of a new type is studied, among the general considerations is chosen, *a priori*, a plan of surfacing. It is well to examine next, by means of predictable calculations, whether the system which it is proposed to adopt approximates nearly enough to a system of uniform wear.

The size of the piece to be surfaced is a primary constant in the choice of a plan of surfacing. If it is very thick one is obliged to work it underneath the tool. If it is small, or thin and concave, it is profitable to work it on top of the tool. If a large output is desired one must try to work as far as possible away from the axis of the lathe, leading to considerable overlap. The maximum permissible overlap is the greatest for which the distribution of the wear is still uniform enough. The distribution of the wear corresponding with the plan of surfacing which it is proposed to follow, must then be calculated.

In work by translation alone the edges are relieved, following a curve depending on the overlap and the effect of the out-of-plumbness which results.

If there is translation and rotation the edges are relieved, following a curve depending simultaneously on the overlap, the tilt and the retardation that results from it (diminution of the speed of rotation of the driven piece by friction).

It is possible to compute, with a sufficient precision, the effect of the relative movement of the glass and the tool, by allowing that at each point the wear is only proportional to the speed of rubbing. This effect can be called "the kinematic effect" since it does not cause the frictional forces, which one supposes to be the same at all points, to intervene.

On the other hand it would be difficult to evaluate the effect of out-of-plumbness which modifies the distribution of the pressure, and the effect of "edge off", which varies with the mean pressure and the size of the abrasive used. These two effects can only be estimated qualitatively.

Here, in the form of an example, is a computation of the kinematic effect on two plates  $L$  and  $U$  (lower and upper) of the same diameter, worked one on the other while overlapping to one half the radius, on an automatic machine.

The wear on a narrow ring whose whole surface is constantly covered by the tool is a function of the distance  $l$  from the centre of the glass to the instantaneous centre of rotation. If the ring is periodically and partially uncovered its wear is, in addition, proportional to the length covered in each element of time.

The law of wear as a function of the distance from the instantaneous centre of rotation is defined by Fig. 35, which shows, with a sufficient approximation, the variation in wear (by kinematic effect) from the wear in the centre represented by  $AC$  to the wear at a distance  $Cd$  from the middle. The circumference (not shown) centred on the axis of the glass and passing through the instantaneous axis of rotation would represent the path of rolling of the tool on the glass. By taking as unity the distance  $l$  from the instantaneous centre to the middle of the glass, this figure applies to all possible cases. If, for example, the instantaneous centre is at a distance from the centre of the glass equal to 1.2 radii of the ring of which the wear is desired to be estimated, one will trace on the curve a cord  $MN$  equal to  $\frac{2l}{1.2}$ . The wear on the ring will be related to the wear in the centre in the ratio  $\frac{Nn}{AC}$ .

Instead of working graphically, the variation of the wear from the centre of the disc to its edge can be calculated by using the formula deduced from Fig. 35 which gives the coefficient  $K$  by which the wear at the centre must be multiplied to yield the wear on a ring of radius  $r$  constantly covered by the tool (braking coefficient  $K = \sqrt{1 + \frac{r^2}{l^2}}$ ).

Now the distance  $l$  from the instantaneous centre to the centre of the tool considered is calculated as shown on p. 116. If  $\omega$  is the speed of rotation of the lathe,  $E$  the eccentricity of the discs and  $\gamma$  the loss of speed of the driven disc

$$l = CX = \frac{E\omega}{\gamma}$$

If, for example, the loss of speed is three turns per minute for an eccentricity of one quarter of the radius and the speed of the lathe is 34 turns per minute,  $l = CX = \frac{34}{3} \times \frac{R}{4} = 2.8R$ .

Fig. 45 shows, by way of example, the distances from the instantaneous centre of rotation to the centres of the discs  $L$  and  $U$  (lower and upper) as a function of the radius of the small disc. These distances have been calculated in the preceding manner. They are deduced from the empirical results on which Fig. 20, which gives the losses of speed as functions of the eccentricity of the discs, is con-

structed. The disc  $U$ , ceasing to turn on itself when its instantaneous centre is on the axis of the lathe (*i.e.* when the distance  $l$  is equal to the

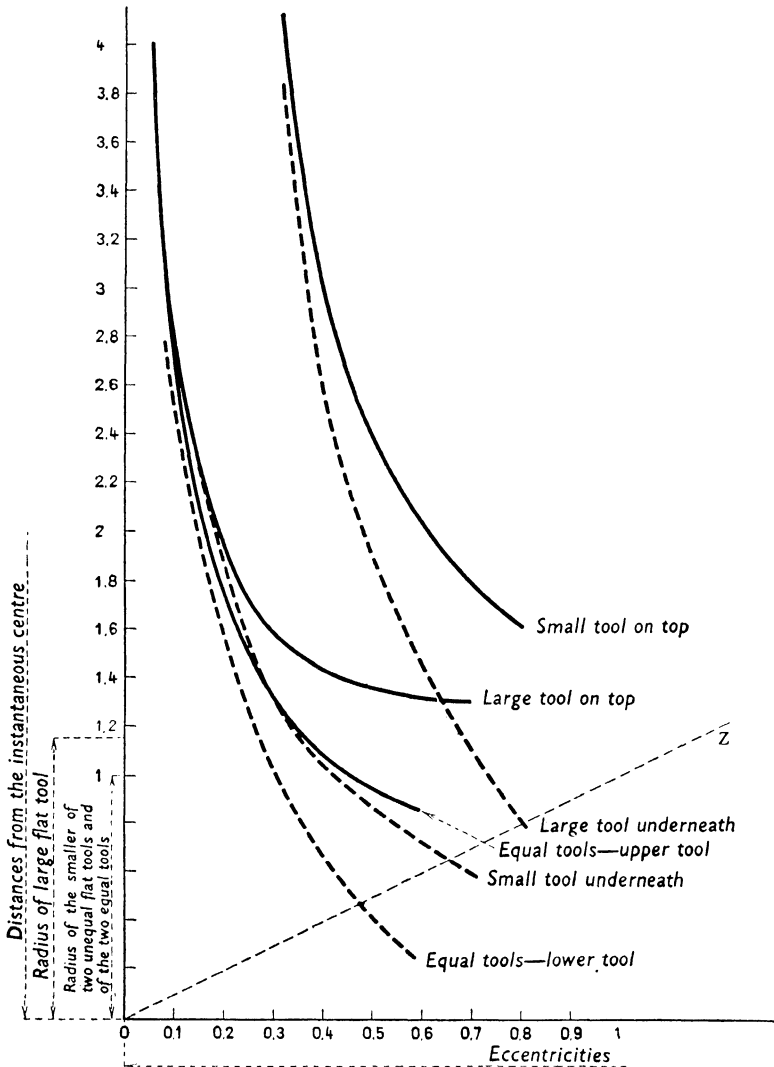

FIG. 45. Distances from the instantaneous centre as functions of the eccentricity of the two tools.

eccentricity), the points of arrest of rotation of the upper plate will be computed by prolonging (in imagination) the curves of these plates

to their intersection with the line  $OZ$  inclined in the relation of the ordinate to the abscissæ of the same numbers.\*

The length covered by a narrow ring during each element of time is measured on a large scale plan taking for the element of time the

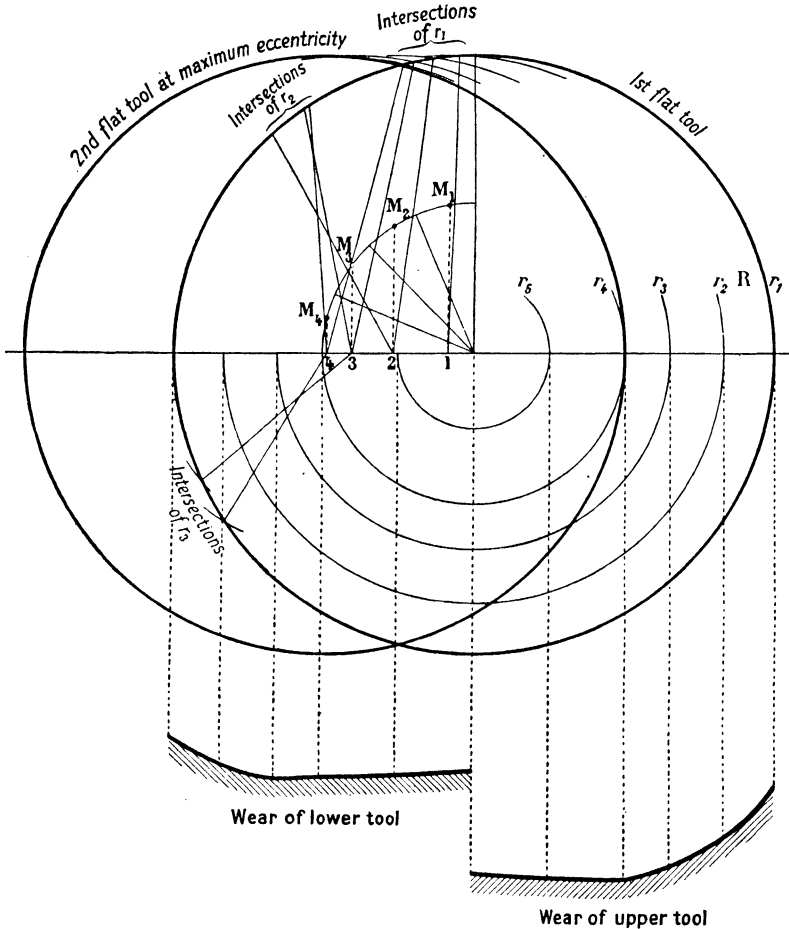

FIG. 46.

period during which the crank (or the eccentric) which governs the translation of the disc carries out  $\frac{1}{12}$  or  $\frac{1}{16}$  of a turn.

It is supposed that the lever stops at  $M_1, M_2, M_3, M_4$  (Fig. 46) at the centre of each fraction of a turn and passes abruptly to the follow-

\* This line would be at  $45^\circ$  if the scales of the abscissæ and the ordinates were the same.

Mean Radii of rings uncovered during each fraction of a period	Eccentricity	Covered arcs divided by 360°	Upper disc of centre C and radius R				Lower disc of centre O and radius R			
			Distance $f = CX$ as a function of R	$r_n = CX$	Coefficient of braking $K$	Wear (product of Cols. 3 and 6)	Distance $l = OX$	$r_n = OX$	Coefficient of braking $K$	Wear (product of Cols. 3 and 10)
1	2	3	4	5	6	7	8	9	10	11
$R = r_1 = 1$	0.1	0.488	2.6	0.385	1.014	0.488	2.5	0.4	1.08	0.527
	0.266	0.455	1.4	0.710	1.184	0.538	1.134	0.88	1.33	0.605
	0.4	0.433	1.1	0.910	1.35	0.584	0.7	1.425	1.47	0.638
	0.475	0.422	1.0	1	1.41	0.595	1.525	1.9	1.9	0.803
		mean	1.5		total	2.205	mean	total	total	2.573
							0.731			
$r_2 = 0.83$	0.1	1	2.6	0.318	1.101	1.101	2.5	0.332	1.05	1.05
	0.266	0.666	1.4	0.589	1.15	0.767	1.134	0.735	1.24	0.83
	0.4	0.566	1.1	0.755	1.25	0.708	0.7	1.185	1.55	0.88
	0.475	0.527	1.0	0.83	1.30	0.685	0.525	1.58	1.87	0.98
				total	3.261			total	total	3.74
$r_3 = 0.665$	0.1	1	2.6	0.256	1.031	1.031	2.5	0.266	1.035	1.035
	0.266	1	1.4	0.476	1.107	1.107	1.134	0.587	1.156	1.156
	0.4	0.755	1.1	0.605	1.168	0.882	0.7	0.95	1.38	1.041
	0.475	0.685	1.0	0.665	1.190	0.816	0.525	1.265	1.64	1.123
				total	3.835			total	total	4.355
$r_4 = 0.31$	0.1	1	2.6	0.119	1.01	1.01	2.5	0.124	1.01	1.01
	0.266	1	1.4	0.221	1.025	1.025	1.134	0.173	1.015	1.015
	0.4	1	1.1	0.282	1.037	1.037	0.7	0.443	1.095	1.095
	0.475	1	1.0	0.310	1.047	1.047	0.525	0.59	1.16	1.16
				total	4.12			total	total	4.28
$r_5 = 0.268$	0.1	1	2.6	0.103	1	1	2.5	0.107	1.005	1.005
	0.266	1	1.4	0.189	1.017	1.017	1.134	0.238	1.027	1.027
	0.4	1	1.1	0.242	1.028	1.028	0.7	0.383	1.07	1.07
	0.475	1	1.0	0.266	1.035	1.035	0.525	0.51	1.122	1.122
				total	4.08			total	total	4.224
Centre of glass										
wear = 4										
Centre wear = 4										
$\times 0.486 = 1.94$										
$\times 0.486 = 2.05$										
$\times 0.486 = 2.12$										
$\times 0.486 = 2.08$										
$\times 0.486 = 1.84$										
$\times 0.486 = 1.325$										
$\times 0.486 = 0.486$										
$\times 0.486 = 0.486$										

ing station. The plan shows, for each station, the arcs covered by each of the concentric circumferences considered. As the lengths of time at each station are supposed to be equal, the sum of the arcs covered at the different stations is one element of the relative measure of the kinematic wear on a given circumference in relation to the wear at the centre of the disc. The other element, of the measure of the relative kinematic wear, is the distance  $l$  from the instantaneous centre of rotation to the centre of the disc considered.

For the execution of such a large scale plan, there are two cases to examine, that of symmetrical overlap and that of unilateral overlap.

In the first case the "dead points" of the crank correspond to the maximum overlap on each side. In the second case one only of the "dead points" corresponds to the maximum overlap, the other corresponds to the perfect centring of the two discs, that is to say, the position at which the wear by rotation is nil. It is necessary to take as much account of the difference in the general wear as in the distribution of the wear according to whether the overlapping is unilateral or symmetrical. The edges are less relieved by unilateral overlapping.

Symmetrical overlapping is studied in the following example.

#### **Calculation of the Distribution of the Wear on two equal Discs ground one on the other on an Automatic Lathe, with Symmetrical Overlap of half their Radius**

The measured or calculated elements can be disposed in the following manner, in a synoptic table giving the wear on the upper and on the lower discs, for several rings of arbitrarily chosen dimensions.

The figures of columns 1, 2 and 3 (see page 137) are measured from the plan (Fig. 46).

The distances of the instantaneous centre (column 4) as a function of the radius of the discs, taken as unity, and of the eccentricity (column 2) are measured from Fig. 45.

The values  $p$  (column 5) are the quotients of the numbers in columns 1 and 4. Those of column 6 are calculated from the formula

$$K = \sqrt{1 + p^2}.$$

The numbers of column 7 are the products of the numbers in columns 3 and 6. They give, for each imaginary station of the crank, the ratio of the wear of the ring under consideration to the wear at the centre of the tool. If the wear at the centre of the tool is taken as a unit of wear during the period of time at a station, the sum of the relative amounts of wear of a ring during the four periods represents approximately four times the total wear on this ring, while the wear at the centre is represented by the number 4. In one complete

turn of the crank the same relative positions of the two occur four times so that only a quarter of a turn need be studied.

The totals which are found in column 7 give the relative amounts of wear of various rings and of the centre, for the upper disc.

The four following columns relate to the lower disc.

The rings under consideration on the lower disc have the same radii as those of the upper disc. Consequently the numbers in columns 1, 2 and 3 also concern the lower disc. The instantaneous centre is nearer to plate *L* than to plate *U*, the differences of the distances being equal to the eccentricity. The numbers in column 8 are the differences of the numbers in columns 4 and 2.

The values of  $p$  (column 9) are the quotients of the numbers in columns 1 and 8. Those in column 10 are calculated by the same formula as those in column 6 but with the values of  $p$  from column 9.

Finally the numbers in column 11 are the products of those in columns 3 and 10.

The totals which are found in column 11 give the relative wear of various rings on disc *L* in relation to the wear at the centre represented by the number 4 (see above).

It must be remarked that the numbers of columns 7 and 11 are not directly comparable, since the centre of the disc *L*, being constantly nearer the instantaneous centre than is the centre of the disc *U*, wears less quickly. The amounts of wear of these two centres are to one another as the means of the distances *CX* and *OX*. These means, respectively equal to 1.5 and 0.73, are indicated in columns 4 and 8. To compare the amounts of wear of disc *L* with those of disc *U*, it is, then, necessary to multiply the figures of column 11 by  $\frac{0.73}{1.5} = 0.49$ .

The curves of wear (Fig. 46) have been established in this way. They show first, that the disc *U* is worn almost twice as quickly as plate *L*; second, that the central part of the disc *L* is a little more convex than that of disc *U*; third, that the edges of disc *L* are less relieved than those of disc *U*. But it must not be forgotten that we are only concerned here with kinematic wear.

The above results can be interpreted thus. If, commencing with perfectly plane surfaces, one continues the surfacing too long, until, for example, even 2 microns is removed in the centre of the upper disc, one will see the edges raised up by 3.3 fringes on the upper disc and 2.5 fringes on the lower disc. The convexities of the central parts are unnoticeable.

It has been supposed that the track of translation of the disc *U* passes through the centre of the disc *L*, but it has been seen that most often, it is preferable to make the track of translation a little eccentric. If in the above example the track of translation was eccentric by

$\frac{1}{10}$  of the radius, this would suppress in the picture all the lines relative to the eccentricity 0.1 and the wear at the centre would be represented by the number 3 (instead of 4). A diminution of the rise of the edges and an increase of the rise of the ring  $r_2$  would result. This paradoxical result is worth our stopping to consider it. The successions of figures in columns 3, 7 and 11 represent the jumps in their progressions, each time that a ring ceases to be completely covered. But this critical point corresponds just to the first line of the table; when the two discs are exactly centred they cover each other completely, but at the slightest eccentricity half the edge of each disc is rapidly uncovered so that the calculation suddenly shows an enormous reduction in wear at the edge. As, on the other hand, the edge is always more or less turned off by the effect of out-of-plumbness, it suffices not to establish the calculation for  $r_1 = R$ , that is to say, for the final edge of the disc, as in the above table, but to establish it for a ring  $r_1$  a little less than  $R$  and only uncovering itself progressively.

All the curves of wear obtained by this method of calculation suppose uniformity of pressure. This condition is never fulfilled when the plate  $U$  is larger than the other because the upper disc, even when it does not overlap, is always eccentric (except for an infinitely short time). In practice, when surfacing is carried out by good and experienced workers, the out-of-plumb effect compensates the relief of the edges resulting from the kinematic effect.

There remains, however, one defect, which all the curves of wear with overlap on an automatic lathe reveal more or less strongly. The profiles all show a strongly localised kink at the limit of the zone which is never uncovered (Fig. 23), but if the machine is so adjusted that the overlap to the left, for instance, is one half of the overlap to the right the kink is split in two, that is to say, there are two kinks, very little accentuated, in place of a single more marked one. On the other hand, such an adjustment being intermediate between symmetrical overlap and unilateral overlap, the edges are less relieved than if the overlap were symmetrical.

In any case, we cannot hope to stumble at the first attempt on really good adjustment of movements and pressures. It is usually necessary to modify these adjustments and pressures, following the indications of a test plate examination of the first surfaces obtained.

If one wishes to obtain perfect surfaces, one is always prevented by the automatic braking caused by the overlap, because this braking has the certain effect of making the central region, which is never uncovered, slightly convex. It is, then, useful to have recourse to the lathe with adjustable relative rotations (see p. 158) in order to impose a constant rotation upon the upper disc. If, also, one wishes to grind away the centre of the lower disc it is possible to do so with such a

lathe by placing the centre of the path of translation appreciably far away from the axis of the lathe and pressing, by the hand or otherwise, on the upper disc from the side of the axis of the lathe. Such a pressure can reverse the effect of out of plumbness but this practice can only be recommended on a lathe assuring constancy of the speed of rotation of the upper disc, for on an ordinary lathe pressure exerted on the upper disc would produce a noticeable braking effect.

The first attempts at surfacing, on a new type of manufacture, give indications which permit decision as to whether it is as well to increase or decrease the mean pressure.

If one wishes to reduce the wear on the edge of the upper plate the employment of a heavy upper plate is indicated and an even heavier one when a coarser emery is used.

If, on the contrary, one wishes to take advantage of the out-of-plumbness to correct the effect of relief of the edges produced by the kinematic effect alone, when working with overlap, the employment of a light upper plate or even one which is counter-balanced is indicated. Hence a very light mean pressure must be used in polishing and the duration of the operation is long.

The preceding considerations do not apply to deeply curved surfaces, for in that case the instantaneous axis of rotation is not displaced parallel to itself but turns around a nearer point, which is the centre of curvature.

## SPHERICAL SURFACES

### Distribution of Wear over the Glass

When there is displacement of the glass on a stationary tool, it can only occur by rotating around a diameter of the sphere. It is only possible to envisage rotations, no translation is possible, as it is on a plane.

The glass can be displaced on a great circle without turning in relation to that circle. It can turn around its axis on a stationary tool. It can slide on a small circle, the same points of the glass remaining in contact with the small circle. When the tool rotates, the glass, held by a rotary driving pin, turns upon itself without moving its position, by simple frictional driving. This rotation of the glass around its axis is susceptible of braking or acceleration by an external force.

It is worth while examining each of these movements from the point of view of the distribution of the wear on the glass in order to predict what their combination should produce.

*1st. Stationary tool, glass sliding on a great circle.* The tool being maintained stationary, if the glass is displaced on a great circle with-

out turning, or while turning very slowly upon itself, the centre which is constantly in contact with the great circle is worn more than a ring chosen near the edges, for, though the points  $A$  and  $C$  (Fig. 47) of that ring are worn by the great circle, all the other points of the ring, and in particular those in the region of  $G$ , are worn by small circles, at the same angular velocity. On the average, then, the ring is less worn than the centre of the glass.

*2nd. Stationary tool and rotating glass, or vice versa.* When the glass rotates on its axis on a stationary tool, its centre is not worn at all, and all other regions of the glass are worn in proportion to their distance from the axis. That is what can occur when the glass is worked with the tool on top of it. It has already been seen that by combining a rotation of the glass on its axis with a displacement on a great circle, speeds can be found for which the two combined systems of wear balance one another, that is to say, for which the wear is distributed in an appreciably uniform manner.

*3rd. Glass sliding on the little circle  $BB'$*  (Fig. 47) in such a way that the same points of the glass rest in contact with the circle  $BB'$ . This is the case of the glass being held in the hand (with a screwed handle) on the rotating tool. The centre of the glass wears in proportion to the radius  $Bb$ , the region  $A$  wears proportionally to  $Aa$ , the region  $C$  proportionally to  $Cc$ , and the two points projected in  $G$  are worn proportionally to  $Kg$ . The mean wear on the ring  $AC$  is, then, proportional to a length intermediate between  $Kg$  and  $Gg$ , the mean of  $Aa$  and  $Cc$ . If this intermediate length is precisely equal to  $Bb$ , the mean

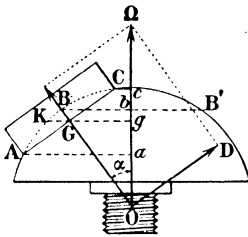

FIG. 47.

wear on the ring equals the wear at the middle. But that equality can only be produced for a certain value of  $\alpha$ . For a smaller value of  $\alpha$  the wear on the ring is more than the wear at the middle and inversely for large values of  $\alpha$ . Thus a small circle of angular aperture  $2\alpha$  exists on which, with the glass sliding, the wear at the middle equals the mean wear on the points  $AGCG$ . The value of  $\alpha$  depends on the angular opening of the ring  $AC$ . It must be noted that when that

aperture increases, one passes through a critical point. In fact, the radius of gyration  $Cc$  diminishes, becomes annulled when the point  $C$  arrives on the axis of the tool and then increases again when the point  $C$  passes to the other side of the axis of the tool. On p. 76 will be found a table of approximate values of  $\alpha$  which give an even wear of the glass, when the glass, not turning or only turning very slowly on itself, remains stationary or is displaced but little and slowly around its mean position.

*4th. Tool rotating and glass held stationary by a central driving pin.*  
 In the case of rather deep curvatures, the concave piece is, as we already know, placed on top. The system of wear which is established in this case is defined by the following theorem.

**THEOREM III**

**When a concave tool is held by a central driving pin on a rotating convex tool, the instantaneous axis of rotation of the concave tool on the convex tool is perpendicular to the axis of the concave tool in the plane containing the axes of the concave and the convex tools.**

*The wear of the concave tool is not uniform but its distribution is independent of the position of the concave tool.*

The central driving pin supports a force which should balance all the forces of friction on the concave tool, or, at least, their projections on a plane normal to the axis of the concave tool. Equilibrium is obtained when the instantaneous axis merges with the perpendicular  $OA$  to the axis  $OB$  of the concave tool (Fig. 48). In effect, all the frictional forces are, then, perpendicular to  $OA$ . They are projected parallel to  $OB$  on the right and left hand of it. To an element of force  $MM'$  on the left there corresponds an element of force  $NN'$  on the right, equal and parallel to it. These are the projections of the equal forces on a plane normal to the axis of the concave tool which, alone, tend to make the tool turn in one direction or the other. All projections, such as  $Mm$ , to the left tend to make the concave tool turn in one direction while those symmetrical with them such as  $Nn$  tend to make it turn in the opposite direction. As they are equal, one to another, and equidistant from the axis projected on  $O$ , their moments balance.

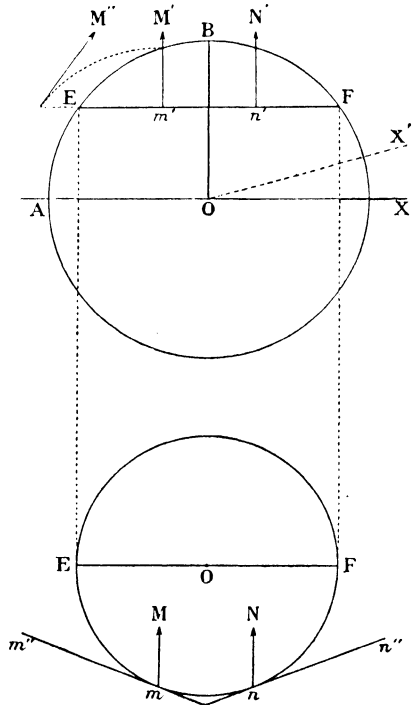

FIG. 48.

This resultant perfect symmetry and equilibrium are changed as

soon as the instantaneous axis ceases to be normal to the axis of the concave tool. In fact, if the instantaneous axis lies in  $OX'$ , the symmetrical forces considered above,  $MM'$  and  $NN'$ , both lean to the left. But these forces, which are equal, must remain in the planes  $mm'$  and  $nn'$ , respectively, tangential to the concave tool. One of them is represented turned down at  $M''$ . As a result the force  $M$  approaches the tangent  $mm''$  and the force  $N$  gets further from the tangent  $nn''$ . It follows that the projection  $Mm$  increases and gets further from the axis projected in  $O$ , while the projection  $Nn$  diminishes and approaches  $O$ ; for these two concordant causes, the effect of the force  $MM'$  becomes preponderant. It is the same for all forces applied at symmetrical points, in such a way that equilibrium is upset.

To re-establish equilibrium, an accelerating or retarding couple must be added to the resistance of the driving pin, according to the position which it is desired to assign to the instantaneous axis. This can be obtained with lathes with adjustable relative rotations.

Since the wear at a point of the concave tool is proportional to its distance from the instantaneous axis, the variation of the wear from one point to another only depends on the position of that axis in relation to the concave tool, always supposing that the elementary frictional forces do not vary when the concave tool is displaced upon the convex tool. Thus, when the instantaneous axis is normal to the axis of the concave tool (that is the case of an ordinary automatic lathe), the distribution of the wear is independent of the position of the concave tool on the convex tool, as has already been seen.

The speed of rotation  $\omega$  of the concave tool is the resultant of the speed of rotation  $\Omega$  of the convex tool and the speed of rotation around the instantaneous axis. If the angles of the parallelogram of velocities are known, or chosen (Fig. 44), and one of the speeds is known the two other speeds can be deduced from it. In the case in which the instantaneous axis is normal to the axis of the concave tool, the parallelogram of velocities shows that  $\omega = \Omega \cos \alpha$ ,  $\alpha$  being the angle which the axis of the concave tool makes with the axis of the convex tool.

It is convenient to consider the automatic relative movement of the glass on the convex tool as the rolling of one circle on another circle. For this the convex tool must be supposed to be an almost complete ball and the concave tool as a hemisphere (Fig. 49).

At the point  $O$  let us draw a perpendicular  $OA$  to the axis of the concave tool. It is, as has been seen, the instantaneous axis of rotation. The point  $A$  taken on the convex tool turns with it with a linear velocity  $\Omega \times Aa$ . The point  $A$  taken on the glass turns with it with a linear velocity  $\Omega \cos \alpha \times AO$ . But  $Aa = AO \cos \alpha$ . Then the point  $A$  on the convex tool and the point  $A$  on the glass are displaced in the

same direction and with the same velocity during an infinitely short time, in other words, the glass rolls on the little circle  $AA'$ . The diameter of the little circle  $AA'$  subtends an angle equal to  $(\pi - 2\alpha)$ . If the summit  $B$  of the glass is immobilised, it is as if the circle  $AA'$  being toothed, geared in with the edge of the glass, the two gear wheels rolling one on the other.

Let us suppose, now, that the lathe is placed at the centre of a little platform turning on itself with a velocity equal to and in a direction contrary to that of the lathe. There will be no change in the relative movement of the glass on the convex tool, but the tool, given two equal

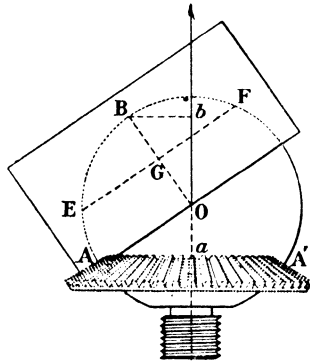

FIG. 49.

rotations opposite in direction, will be stationary with respect to the workshop, and the workman, standing beside the rotating platform, will see the circle  $AA'$  stationary and the glass rolling on itself like a wheel on a circular track, the point  $B$  turning around the tool with a velocity  $-\Omega$ .

For the study of the distribution of wear on the glass the value of  $\Omega$  is unimportant, and the amounts of wear at different points are proportional to the distances of these points from the instantaneous axis. In the case of free rotation, the instantaneous axis is at  $OA$  (Fig. 49), and the wear at  $B$  is proportional to  $OB$ . The mean wear at  $E$  and at  $F$  is proportional to  $OG$ . In the two regions projected on  $G$  the wear is equal to the wear at  $B$ , since the points  $G$  and  $B$  are on the same great circle perpendicular to  $AA'$ . Thus the mean wear on the four points  $E, G, F, G$  is equal to  $\frac{OB + OG}{2}$ . Taking the radius

$OB$  as unity and calling the angular aperture of the glass  $2\beta$ , one has

$$\frac{OB + OG}{2} = \frac{1 + \cos\beta}{2}.$$

The angle  $\alpha$  only influences the rapidity of wear, which is proportional to  $Bb$ ; that is to  $\sin\alpha$ .

### Distribution of the Pressure

If the pressure could be supposed to be uniformly distributed over the whole surface of the glass, the centre would always be the most worn. But this inequality is still increased owing to the fact that the pressure is less at the edges than it is in the centre. At the edges of a hemisphere the pressure can even be considered as null, for, by pressing a glass on a rotating hemisphere for a long while one would finish by making a deep hole whose diameter would only be that of the ball.

It can be taken, approximately, that the pressure at a point distant from the summit of the glass by an angular aperture  $2\beta$  is equal to the pressure at the summit multiplied by a coefficient  $K$  equal to  $\cos\beta$ , in considering surfaces which have no plasticity, such as surfaces of metallic tools, or the surface of a glass worked alone. The coefficient  $K = \sqrt{\cos\beta}$  is to be preferred when smoothing a block of glasses on mallets is concerned or in pitch polishing. The adoption of these coefficients can be justified as follows.

The grains of abrasive embed themselves in the tools; they then produce there small permanent deformations, but every permanent deformation is preceded and accompanied by an elastic deformation. The tools can thus be considered as being endowed with elasticity, with a margin of local elastic deformations of the order of a fraction of a fringe. Commencing with this consideration let us imagine that a mattress of minute spiral springs is interposed between a convex tool and a concave tool of slightly longer radius, the length of the free springs being equal to the difference in radii of the two tools. Under the pressure exercised by the concave tool the springs of the central region are reduced to a certain length  $e$ . It follows that the distance measured between the tools at an angular distance  $\beta$  from their summit will be reduced to  $e \cos\beta$ . As the pressures of the springs are proportional to their compressions, the pressure of those decentred by an angle  $\beta$  is equal to that at the centre multiplied by  $\cos\beta$ . Equilibrium being established, the pressures are then distributed according to a cosine law. The same result should be obtained in the case of glasses blocked on pitch mallets; each mallet flattens itself under prolonged pressure; those which support an abnormal pressure flatten more than the others until equilibrium is attained, that is to say, until the total pressure is distributed according to a cosine law. If the mallets at the edge flattened out more than the cosine law demands, they would not support more pressure. If they flattened less, the mallets in the central region would not bear.

The same thing does not hold in the case of a plastic polisher. In a plastic body, pressures balance themselves throughout the mass, although slowly. If a pitch polisher could be surrounded with a flange preventing it from spreading beyond the circumference, equality of pressures would establish itself over all the surface during one whole pass of polishing. As such a flange cannot exist the pitch at the marginal region of the polisher must overflow under the pressure and the balance of pressures can only establish itself up to a certain distance from the edge.

If the balance of pressure could establish itself exactly the coefficient  $K = \cos\beta$  would have to be replaced by unity. In the case of pitch polishers the coefficient  $K = \sqrt{\cos\beta}$ , nearer to  $\cos\beta$  than to 1 appears, then, to be suitable.

It is to be remarked that the law of distribution of pressures according to the coefficient  $K = \sqrt{\cos\beta}$  is less suitable to polishers which are cut into squares or relieved since, in these cases, the pitch behaves itself like the blocking cement in overflowing into the spaces. Moreover, as the balance of pressures is only able to establish itself slowly, there is always a period of delay during which the pressure diminishes most quickly in the regions which are rubbed with the greatest speed; for this reason, again, the coefficient  $K = \cos\beta$  is generally too small.

Thus, the coefficient  $K = \cos\beta$  is principally suitable for the case of trueing up two tools or for that of smoothing a glass of larger aperture worked by itself. The coefficient  $K = \sqrt{\cos\beta}$  is preferable for all other cases. If the cement, or the pitch, is very hard, the most suitable value of  $K$  must lie between  $\cos\beta$  and  $\sqrt{\cos\beta}$ . If the cement, or the pitch, is more plastic, either because of a greater content of spirit, or because of the temperature of the workshop, or because of the warming produced by rapid surfacing, the true value of  $K$  can be greater than  $\sqrt{\cos\beta}$ . It can never in any case attain to unity.

On the other hand, it has been seen that the wear, without being proportional to the pressure, increases with it between the limits of useful pressures. There is, then, a certain approximation to the amount of wear in supposing it proportional to the pressure for the usual mean pressures.

Following this hypothesis, it is found that, in the case of a glass or a tool of large aperture worked on an automatic lathe (with free rotation) the wear is distributed as in the table on page 148.

In most cases it is the figures of the third column which must be retained. The most probable values are generally between those of the second column and those of the third. It follows that the two values  $K = \cos\beta$  and  $K = \sqrt{\cos\beta}$  are always taken into consideration.

The to and fro movement which is given to the driving pin guiding

$B = \frac{1}{2}$ the aperture of the ring	Mean wear on the ring in relation to the wear at the summit $(1 + \cos \beta) \times \frac{K}{2}$		
	$K = \cos \beta$ elastic surfaces	$K = \sqrt{\cos \beta}$ slightly plastic surfaces	$K = 1$ very plastic surfaces
0°	1.00	1.00	1.00
10°	0.98	0.99	0.992
20°	0.91	0.94	0.97
30°	0.81	0.87	0.933
40°	0.67	0.77	0.883
50°	0.53	0.66	0.821
60°	0.35	0.50	0.750
70°	0.23	0.40	0.671

the concave tool does not modify the above table. Indeed this movement is a rotation around a diameter situated in the plane perpendicular to the axis of the concave tool. This additional rotation cannot, then, cause the instantaneous axis to depart from this plane.

*Thus the wear of a concave tool is always distributed nearly as indicated in this table, when it is held in place by a central driving pin (whatever the angular distance from the summit of the convex tool), if the rotation of the concave tool is not subject to any retardation.*

#### THEOREM IV

**When a concave tool is ground in with a convex tool of the same angular aperture on an ordinary automatic lathe the concave tool wears more quickly than the convex, but this law can be reversed by surfacing on a lathe with adjustable relative rotations (see page 158).**

The importance of the relative positions of the three centres, or, what comes to the same thing, of the three axes passing through those centres, for the surfacing of two flats, has been seen (the axes of each of the flats and the instantaneous axis). The tool which is rubbed with the greatest speed, and which in consequence wears away most quickly, is that which is situated furthest from the instantaneous axis. It is the same in the case of spherical surfaces, although these axes converge.

The lathe with adjustable relative rotations allows one to give the inclination which is desired to the instantaneous axis. To reverse the law of relative wear of the two tools, it suffices to give to the instan-

taneous axis a position symmetrical with that which it occupied on the ordinary automatic lathe. For this a speed must be impressed on the concave tool which exceeds the speed of the convex tool by as much as the speed of the convex tool surpassed that of the concave tool on the ordinary automatic lathe. This system of working is preferable in industry, because it wears the glass more quickly and the tool less quickly.

**Retarded Rotation**

The instantaneous axis of rotation is only normal to the axis of the glass for an automatically induced rotation. If, by some special mechanism, the speed of rotation of the glass is accelerated without

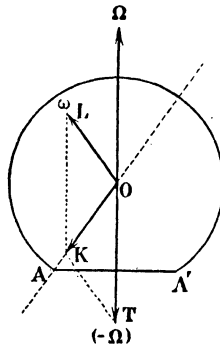

FIG. 50.

changing that of the lathe the instantaneous axis approaches the horizontal. On the contrary, if the rotation is retarded till it nearly stops, the diagrammatic pinion diminishes until it disappears. For a zero speed of rotation, the instantaneous axis obviously merges with that of the lathe. The following, then, is the construction for the instantaneous axis in the general case (Fig. 50).

Let  $\Omega$  be the speed of rotation of the lathe,  $\omega$  the speed of rotation of the glass, obtained by some mechanism and represented by  $OL$ , the glass turning on itself without displacement.

To study the relative movement of the glass in relation to the tool let us give to the whole a velocity  $-\Omega$  which will immobilise the tool. The glass is, then, governed by its speed  $\omega$  and the speed  $-\Omega$  represented by  $OT$ . The resultant of these two speeds is obtained by constructing the parallelogram  $LOTK$ . The resultant  $OK$  is directed along the instantaneous axis sought, and the little circle  $AA'$  represents diagrammatically the conical pinion on which the glass rolls. When  $\omega$  is nil, that is to say, when the glass is completely retarded, the

parallelogram of rotations is completely flattened on the axis of the lathe and the wear is measured by arcs described around the axis of the lathe instead of in relation to an oblique instantaneous axis.

### THEOREM V

By realising a judiciously chosen inclination of the instantaneous axis of rotation it is possible to ensure a uniform wear of three concentric rings and the centre of a glass or of a spherical tool.

Let  $EF$  (Fig. 51) be a ring belonging to a concave tool whose summit is at  $B$ ,  $OX$  a position of the instantaneous axis.

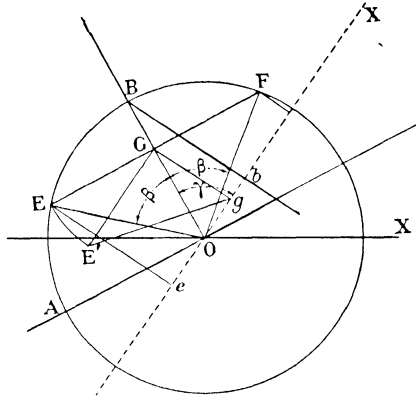

FIG. 51.

Contenting oneself with an approximation, it can be said that the wear on the ring is characterised by the wear of four equidistant points on that ring, the points  $EF$  and the two points projected in  $G$  whose distances from  $OX$  are equal to  $gE'$ . The wear on the summit is proportional to  $Bb$ .

Let us call the ratio of wear  $U$ , the quotient of the characteristic of wear of a ring divided by the characteristic of wear at the summit. On the other hand, it can be taken approximately, as has been seen before (p. 146), that the pressure, and consequently the wear, at a point is proportional to a certain coefficient  $K$  which was taken, according to the case, as equal to  $\cos\beta$  or to  $\sqrt{\cos\beta}$ .

From these hypotheses one can write

$$U = \frac{\sin(\beta + \gamma) + \sin(\beta - \gamma) + 2\sqrt{\sin^2\beta + \cos^2\beta \sin^2\gamma}}{4 \sin \gamma} \times K.$$

$\gamma$  being the angular distance from the instantaneous axis to the axis of the concave tool, and the sines always being taken in absolute values. If the surfaces were slightly malleable (pitch polishers) the value  $\sqrt{\cos\beta}$  would be given to the coefficient  $K$ .

By making  $U = 1$  a relation is obtained which is translated by the curve of Fig. 52. The ordinates are the inclinations  $\gamma$  which the instantaneous axis must bear to the axis of the concave tool, in order that a ring whose semi-aperture is read on the scale of abscissæ shall be worn as much as the centre of the concave tool.

The condition that the term  $\sin(\beta - \gamma)$  is always to be taken in absolute values, implies that the geometric locus sought for, defined by the equation  $U = 1$ , is in reality composed of two curves each representing one of the following equations,

$$U = \frac{\sin(\beta + \gamma) + \sin(\beta - \gamma) + 2\sqrt{\sin^2\beta + \cos^2\beta \sin^2\gamma}}{4 \sin \gamma} \times K$$

and

$$U = \frac{\sin(\gamma + \beta) + \sin(\gamma - \beta) + 2\sqrt{\sin^2\beta + \cos^2\beta \sin^2\gamma}}{4 \sin \gamma} \times K.$$

As it is convenient to give the value  $\sqrt{\cos\beta}$  to  $K$  when the surfaces in contact possess a certain plasticity and the value  $\cos\beta$  when they have none, there are in reality four curves in Fig. 52.

The two curves corresponding to a similar value of  $K$  are tangential

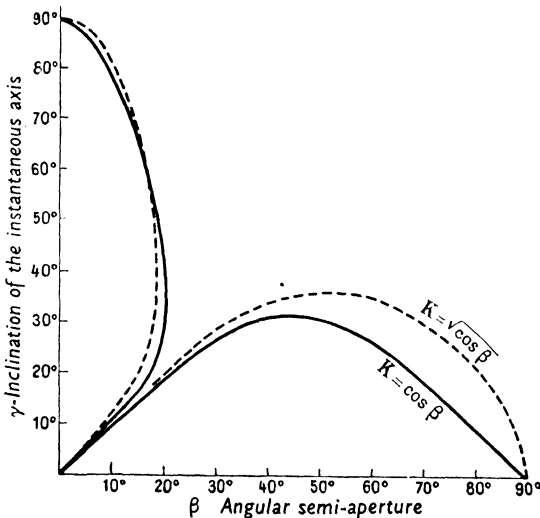

FIG. 52.

to the origin of the co-ordinates along the bisector of the axes of the co-ordinates. For all the points situated to the right of that bisector,  $\beta > \gamma$ , and the curve on the axes of  $\beta$  is related to the first of the two equations above. For all the points situated to the left of the bisector,  $\gamma > \beta$  and the curve on the axes of  $\gamma$  is related to the second of the above equations.

When,  $\gamma$  being very close to  $90^\circ$ ,  $\beta$  tends to be annulled, the segment of the sphere of aperture  $2\beta$  tends to merge with the plane tangent to its summit. The intersection of this plane with the instantaneous axis inclined at  $90^\circ$  is at infinity. Thus one comes back to the case of plane or slightly curved surfaces worked on an automatic lathe with free rotation and with no overlap.

The almost vertical branch of the curve indicates that, where it is desired to equalise the wear at the centre and the wear on a ring of semi-aperture  $10^\circ$  to  $20^\circ$ , there is great latitude in the inclination of the instantaneous axis, which can vary, without disadvantage, from about  $15^\circ$  to  $80^\circ$ .

The aperture of  $18^\circ$  can be considered as a limit separating the employment of surfacing processes for plane or slightly curved surfaces from the employment of processes peculiar to spherical surfaces. Above an aperture of  $18^\circ$  application of the method of carrying out a surfacing project for plane surfaces can give a worth while approximation.

It is to be remarked that the optimum inclinations indicated in the table on p. 76 are figures taken from the curve of Fig. 52. These inclinations concern the case in which the glass (or the concave tool) is held in the hand without turning. In this case, the instantaneous axis coincides with the axis of the lathe, and the values  $\alpha$  of the table are the values  $\gamma$  of the curve.

This curve makes obvious this interesting peculiarity that, by causing the instantaneous axis to oscillate between  $0^\circ$  and  $36^\circ$  the equalisation of the wear on three concentric rings and at the summit is assured. Thus for an inclination of  $28^\circ$  the wear is equal on the rings having for  $K = \cos\beta$  about  $18^\circ$ ,  $33^\circ$ , and  $53^\circ$  and at the summit. That is to say, that practically the whole of the surface is worn uniformly, if its aperture does not exceed  $120^\circ$ .

By making  $\gamma = 28^\circ$  and  $\beta = 38^\circ$  in the formula one finds  $U = 1.09$ , which shows that, if the centre is worn away to the extent of 1 micron, the band comprised between the circumferences  $\beta = 31^\circ 30'$  and  $\beta = 53^\circ$  is worn a little too much, but the depth of the trough thus formed does not attain to one tenth of a micron.

The preceding reasoning applies to the case of a block of concave lenses worked on a convex tool mounted on the axis of the lathe. But to pass to the case of a block of convex lenses mounted on the axis

of the tool it suffices to consider the line  $OB$  of Fig. 51 as the axis of the lathe turning with a speed  $\Omega$  (Fig. 50) while the concave tool (not shown) turns with a speed  $\omega$ . The angle  $\gamma$ , the resultant of the velocities  $\omega$  and  $\Omega$ , is then calculated from the axis of the lathe instead of from the axis of the concave tool. Nothing is changed in the formulæ which derive from Fig. 51, since the velocities  $\Omega$  and  $\omega$  do not enter into them, but the difference of the respective values of  $\gamma$  for the convex and concave tools is equal to the inclination  $\alpha$  (Fig. 47) of the axis of the concave tool to the vertical.

This observation is important because it dispenses with any distinction, in this work, between the cases of concave or convex blocks.

### TRUEING UP A CONVEX AND A CONCAVE TOOL

On an ordinary automatic lathe, the instantaneous axis, being usually perpendicular to the axis of the concave tool, is not generally normal to the axis of the convex tool. If the mean inclination of the axis of the concave tool is  $15^\circ$  the mean inclination of the instantaneous axis to the axis of the convex tool is  $75^\circ$ . By taking  $\gamma = 90^\circ$  for the concave tool and  $\gamma = 75^\circ$  for the convex tool in the above formula, the values of  $U$  for any similar value of  $\beta$  are little different. Thus, so long as the mean inclination of the axis of the concave tool does not exceed  $15^\circ$  the progress of the wear is appreciably similar on both the tools. Instead of tending to a common curvature the concave tool tends to become more deeply curved and the convex tool less deeply curved.

To prevent this systematic fault, the tools may be trued up on a lathe with adjustable relative rotations, suitably adjusting the ratio of the speeds in such a way that the instantaneous axis has a mean inclination between that which is best suited to the convex tool and that which is best suited to the concave tool. Thus, by adopting an angle of  $10^\circ$  for the mean inclination of the axis of the concave tool, an inclination of  $28^\circ \pm 5^\circ$  with the vertical could be given to the instantaneous axis. The construction of the figure shows that for a speed of rotation of the concave tool of  $\omega = 40$  revolutions per minute the convex tool must be given a speed of  $\Omega = 20$  r.p.m. or 54 r.p.m.

The speed of  $\Omega = 54$  r.p.m. wears the convex tool slightly more quickly than the concave tool; the speed  $\Omega = 29$  r.p.m. wears the concave tool more quickly than the convex tool. Thus it would be as well to give the convex tool speeds of 29 and 54 r.p.m. successively. The axis of the concave tool could oscillate, for example, between  $(-4^\circ)$  and  $(+14^\circ)$ , because the amplitude of oscillation of the instantaneous axis is much smaller than that of the axis of the concave tool.

### WORKING OUT A SURFACING PROJECT

With an ordinary automatic lathe, one can only affect the instantaneous axis of rotation by retarding the speed of induced rotation by hand or by means of overlapping; yet this adjustment is only stable so far as the lubrication of the abrasive remains perfect, for as soon as the moist abrasive commences to dry up, the induced speed of rotation is modified. Overlapping increases the relief of the edges, already most often commenced by a lesser pressure at the edge than in the centre.

In order to find if the retardation obtained is acceptable the numbers of revolutions per minute of the concave and convex tools are measured, the mean inclination of the axis of the concave tool is noted, and the parallelogram of speeds (Fig. 50), from which is measured the angle between the instantaneous axis and the axis of the concave tool, is constructed. By obtaining this angle from Fig. 52, or even with the help of the formula on p. 150, it will be seen whether the distribution of wear will be suitable. If not, another arrangement is tried out, including a smaller block and another mean inclination of the concave tool.

With a lathe with adjustable relative rotations one has complete control over the inclination of the instantaneous axis.

When a block of concave lenses is concerned, it will be made as large as possible, choosing the most convenient mean inclination of the concave tool and without taking into consideration the speed of induced rotation. A speed of rotation less than that of the lathe will be imposed on the concave tool, but determined from a scale diagram so as to place the instantaneous axis, as the case may be, at  $28^\circ$  or  $30^\circ$  or  $34^\circ$  from the axis of the concave tool, which is supposed to be fixed in the mean position chosen. The choice of that position will take into account the condition of having so little overlap that the glasses blocked on the edge of the block are not sacrificed.

*Example.* Let us suppose that a pair of tools of  $140^\circ$  aperture are to be trued up together, and that it is decided to make the concave tool oscillate around a mean position with the axis inclined at  $10^\circ$ . What speed of rotation  $\omega$  must be imposed on the concave tool, the speed of rotation of the lathe being  $\Omega$ .

To make the intervals of the rings of equal wear almost equal, the instantaneous axis must be set at  $29^\circ$  from the axis of the concave tool. But the to-and-fro movement of the driving pin, adding a rotation around a diameter normal to the axis of the concave tool, deflects the instantaneous axis, resulting from the two other rotations, a little

from the vertical, especially when the track of the driving pin is de-centred. To compensate for this effect the instantaneous axis resulting from the first two rotations could be inclined to  $25^\circ$  (let us say) instead of  $28^\circ$  or  $29^\circ$ . It would then be at  $15^\circ$  from the vertical. The parallelogram of velocities gives  $\frac{\omega}{\Omega} = \frac{1}{1.6}$ . If  $\Omega = 34$  r.p.m.  $\omega$  should be set at

$34/1.6 = 21$  r.p.m. Or equally well, if it is simpler to give  $\omega$  the value of 24 r.p.m. the convex tool can be given the speed of 38.5 r.p.m.

If the axis of the concave tool is stabilised, equality of wear establishes itself between circumferences of semi-aperture equal to  $18^\circ$ ,  $35^\circ$  and  $53^\circ$ . The edge will be raised up, a trough will be formed between  $35^\circ$  and  $53^\circ$ , a high place will have its summit at about  $24^\circ$  and a projection will form in the centre; these unevennesses being of the order of a small fraction of a band, so long as the surfacing is not pushed unreasonably far. But with the concave tool oscillating, these unevennesses must shade off until they become invisible. To accentuate this shading off, it will be useful to accentuate the oscillations momentarily, for example, to extend their limits to  $20^\circ$  and  $35^\circ$ . The results of the first trials will show whether it is necessary to modify this amplitude.

Fig. 53a, b, c, d and e give the curves of wear on a half segment, almost a hemisphere, for five values of  $\gamma$  which represent stronger and stronger braking forces on the rotation of the concave tool. The ordinates are the amounts of wear and the abscissæ the angular semi-apertures.

Fig. 53a gives the curves of wear on an automatic lathe with free rotation ( $\gamma = 90^\circ$ ). Comparing this figure with Figs. 53b, c, d and e, it is seen that, of all systems that of free rotation is the one which most hollows out the centre of the surface in relation to the zone. This difference of wear from the centre to the edge is reduced when the surfaces are slightly plastic, since the curve  $K = \sqrt{\cos\beta}$  is less concave than the curve  $K = \cos\beta$ . The curve  $K = 1$  is an inaccessible limit and is only given there to show that the curve  $K = \sqrt{\cos\beta}$  is far removed from it.

The comparison of the curves  $K = \sqrt{\cos\beta}$  and  $K = \cos\beta$  justifies the workshop practice of making blocks on fairly malleable cement and using pitch polishers kept lukewarm, which should give a curve of wear very close to the curve of  $K = \sqrt{\cos\beta}$ . If this practice is justified, that which consists in surfacing very open blocks, on automatic lathes with free rotation, is not. A glance at Figs. 53b, c, d, e, suffices to show how important it is not to leave to chance the choice of the inclination of the instantaneous axis of rotation.

Curve 53b is already better than curve 53a, but it shows that an

inclination equal to or greater than  $40^\circ$  is only admissible for blocks of very small angular aperture.

Fig. 53c shows that the angle  $\gamma = 35^\circ$  can be suitable for truing up tools whose aperture is not greater than  $100^\circ$ , or for pitch polishing blocks of  $120^\circ$  to  $130^\circ$  aperture.

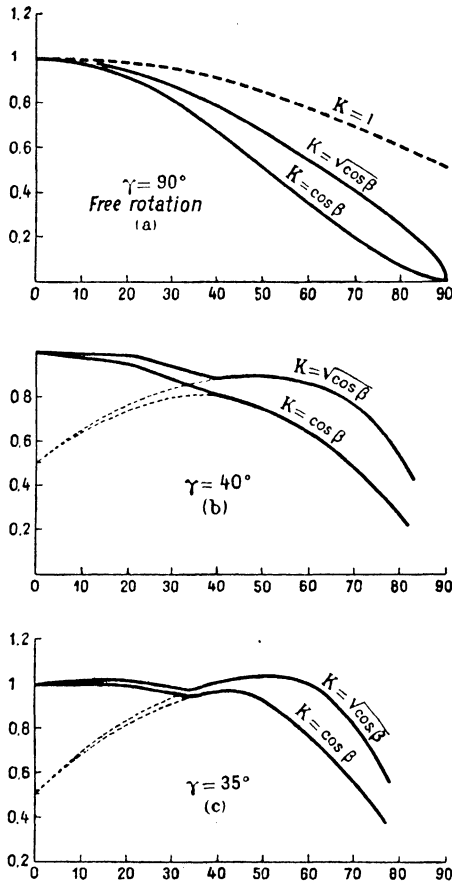

FIG. 53, a, b, c. Distribution of wear for three values of inclination of the instantaneous axis of rotation.

Fig. 53d shows that with an angle of  $\gamma = 28^\circ$  tools with an aperture of  $120^\circ$  can be trued up together. With this angle it is equally possible to surface blocks up to an aperture of  $140^\circ$ , but on condition that the overlap is adjusted according to the angle  $\beta = 28^\circ$ . Indeed, it has been seen in studying the overlap that it always produces on the curve of

wear a kink situated on the limiting circumference which is never uncovered, but the concavity of this kink is in a direction contrary to that of the bend of all the figures 53. Overlaps, by reducing the wear on the marginal zone, thus bring back these curves towards the horizontal.

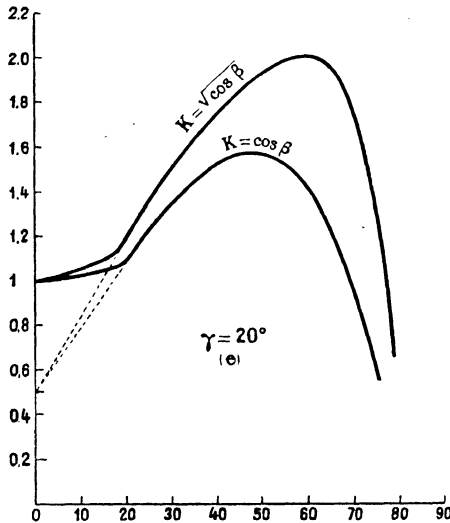
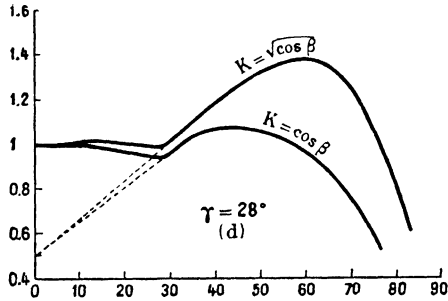

FIG. 53, d and e. Distribution of wear for two further values of  $\gamma$

It is to be remarked that the kinks in the curves of wear of the figures 53 are situated on the circumferences traversed by the instantaneous axis of rotation. For that value of  $\gamma$  the first equation of p. 151 is abruptly abandoned for the second. From this observation the following rule results. *When the instantaneous axis does not traverse the block (or the tool) too far from the edge, the overlap should be adjusted*

to begin from the circumference cut by the instantaneous axis in its mean position.

In the case of a convex block the foregoing observations are still applicable, but it has been seen that the concave tool must be rotated faster than the convex, if it is desired that the surfacing shall be as rapid for convex lenses as for concave lenses of the same curvature. If, for example, the angle of  $10^\circ$  is chosen for the mean inclination of the axis of the concave tool, the instantaneous axis will make, on the same side, an angle of  $25^\circ$  with the axis of the concave tool. The scale diagram indicates a ratio of speeds of 1 : 0.4. For example, the speed  $\omega = 40$  r.p.m. could be given to the concave tool and a speed of  $\Omega = 16$  r.p.m. to the convex one.

Thus the use of the lathe with adjustable relative rotations permits the surfacing of blocks often larger than can be worked on an ordinary automatic lathe and the acceleration of the surfacing of convex lenses.

The lathe with adjustable relative rotations permits the realisation of the best system of wear by various devices, notably by the systematic reduction to a suitable extent of the speed of rotation of the concave tool in relation to that of the convex tool, to place the instantaneous axis of rotation at the optimum inclination. The same result can be obtained on an ordinary automatic lathe, by adding to it a special device for retarding the natural speed of rotation of the concave tool, in such a way as to establish the relationship required by theory between the speeds of the convex and concave tools. Such devices have been produced under the name of "valseurs".

Lathes with adjustable relative rotations and "valseurs" still being but little known\* it is useful to give a brief description of them. They are in service at the Institut d'Optique théorique et appliquée, where they have been studied for applying, in the best way, the laws of surfacing which have just been set forth.

#### LATHE WITH ADJUSTABLE RELATIVE ROTATIONS

Fig. 54 shows a deeply curved concave tool being worked, guided by a ball-pointed pin. This pin belongs to the valseur V, a little device which will be described later, but it could be fixed directly on the bridge bar A which carries the valseur. The ball point of the driving pin is traversed by a little bar whose extremities engage in two grooves formed in the socket of the concave tool, in order to give a direct drive from the ball pin to the concave tool.

\* Brevetés, S.G.D.G. They are described in detail in the *Revue d'Optique*, years 1930 and 1931.

The bridge bar *A* is given an adjustable to-and-fro movement between two forked guide posts. A counterpoise *B* allows the pressure exerted on the concave tool by the bridge bar to be regulated.

The box *D* is that of the regulating resistance and reverser controlling the electric motor *E*.

As in ordinary lathes, the rotation of the convex tool is controlled

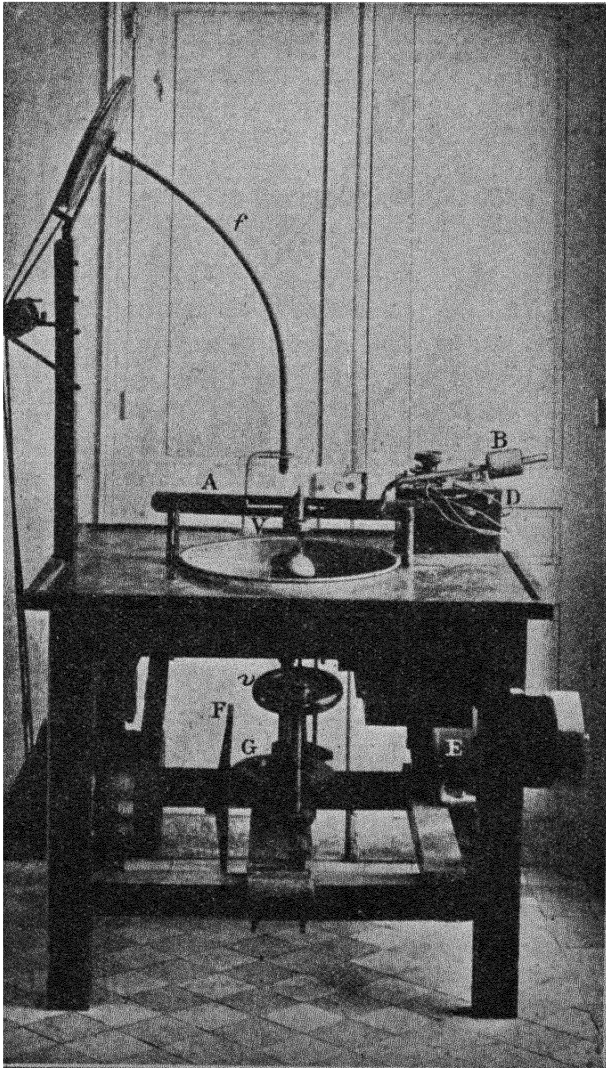

FIG. 54. Lathe with adjustable relative rotations.

by the friction discs  $F$  and  $G$ . The speed of the disc  $G$  is regulated by displacing it by means of a lever controlled by the hand wheel  $v$  with an irreversible screw. The spindle of the disc  $F$  carries on its left extremity a cone of vee drive pulleys which, by belts and other pulleys, governs the rotation of the flexible drive  $f$ . This flexible drive terminates in a square socket which can fit over the squared end of the ball-pointed driving pin. In the figure, the flexible drive is not in use and a hooked rod holds it back in a position of rest.

The cone of pulleys, and a set of interchangeable pulleys, serves to give the desired number of speeds to the flexible drive, but the hand-wheel  $v$  allows any relation whatever to be obtained between the speeds of the flexible drive and the convex tool, and, in consequence, of the concave to the convex tool.

The amplitude of the oscillations of the bar  $A$  is regulated by a mechanism which is not visible in the figure.

### VALSEURS

“Valseurs” are little devices which are interposed between the driving pin and the bar  $A$  of the lathe with adjustable relative rotations, or between the socket of the concave tool and the oscillating arm of an ordinary automatic lathe. They have the object of greatly increasing the path followed out by the projection of the driving pin on the convex (or plane) tool mounted on the axle of the lathe, and also to retard the rotation of the piece driven by the driving pin.

It has been seen that in most instances it is as well to make the translatory motions predominate over the rotations, for (at least for plane or slightly curved surfaces) the system of translation alone is a system of uniform wear.

The retardation is useful for increasing the wear of the zone in relation to that at the summit.

The “valseurs” work on the following principle.

If one wishes to immobilise completely a glass guided by a ball-pointed driving pin on a rotating plane tool, the driving pin must bear a force  $F$  equal to the force by which the glass is dragged round by the plane tool. Moreover, a couple  $K$  must be applied to the glass (with the hands, for instance) in order to prevent it turning around the driving pin.

If  $P$  is the total pressure of the glass or of the block of glasses on the tool,  $f$  the coefficient of friction at the moment and  $\rho$  the radius of the glass or the block when the glass or the block, commencing from the centre position on the plane tool, gets further and further away, the tool being supposed to be very large, the force  $F$  starts from zero and tends towards the value  $Pf$ . At the same time a couple  $K$ , starting from

the value  $2/3Pf\rho$  diminishes until it is annulled when the glass is indefinitely decentred.

If, without completely arresting the rotation of the glass, one retards it, the instantaneous centre of rotation  $X$  of the glass on the flat tool assumes a position at a certain distance  $CX$  from the centre of the glass, which depends on the ratio of the velocities of rotation of the glass and the tool (see p. 127). When the instantaneous axis is inclined in such a way as to pass exactly through the edge of the glass this corresponds with a critical point on all the curves 53  $a-e$  marked by a kink.

The values of  $FK$  for this critical position can easily be calculated from the theoretical considerations on which the fundamental theorem rests. Resolving the surface of the glass into very narrow elementary sectors having their summits at the instantaneous centre of rotation  $X$  (Fig. 41) situated in this case on the edge of the glass, it is remarked that all resultants of friction of the elementary sectors cut the diameter passing through  $X$  in the same point situated at  $\frac{2}{3}$  of the diameter of the glass from the point  $X$ . On summing geometrically all these concurrent elementary resultants the total resultant  $F$  is obtained.

The couple  $K$  is equal to  $\frac{F\rho}{3}$ . Thus it is found that  $F = 2.13Pf\rho^2$  and that  $K = 0.71Pf\rho^3$ . As the glass gets further away from the axis of the lathe the ratio  $\frac{F}{Pf\rho^2}$  assumes the values zero, 2.13 and infinity, at the same time as the ratio  $\frac{K}{Pf\rho^3}$  takes the value  $\frac{2}{3}$ , 0.7, 1 and zero.

$F$  and  $K$  represent the potential frictional dragging force of the glass when held by a central ball-pointed pin on a rotating flat tool. That is to say, that one can use a part of the force  $F$  or a part of the couple  $K$  to execute any mechanical work. "Valseurs" borrow a little of the energy represented by  $K$  or  $F$  to transform it into useful work, and this work consists in causing the driving pin to trace curls around its mean trajectory. The energy thus borrowed from  $K$  or  $F$  produces, at the same time, a retardation or an acceleration of the rotation.

The curls described by the driving pin can be in the direction of the rotation or in a contrary direction. Optical tools generally turn to the left (a contrary direction to that of the hands of a clock). "Valseurs" which describe their curls in this direction are called "left-handed valseurs". Those which describe them in the opposite direction are called "right-handed valseurs".

Figs. 55 and 57 show these two valseurs diagrammatically.

The glass support transmits its rotation to the ball-pointed driving pin through the little bar on the ball ( $D$ , Fig. 56), lodged in grooves formed in the socket. The driving pin is fixed on the planet wheel.

The planet wheel guided by the crank  $DC$  and dragged by the couple  $K$  or by the force  $F$ , turns around the fixed pinion centred at  $D$  on the bridge bar  $A$  (or on the oscillating arm of an ordinary surfacing lathe). Thus the couple  $K$  or the force  $F$  obliges the planet wheel to drag the glass on a circular track which would be fixed in space if the bridge bar did not oscillate. But the actual track described by the driving pin on the rotating tool is not a circle since the bridge bar oscillates and the flat tool turns. Moreover, and to prolong yet more the track described on the flat tool, the driving pin is some millimetres eccentric

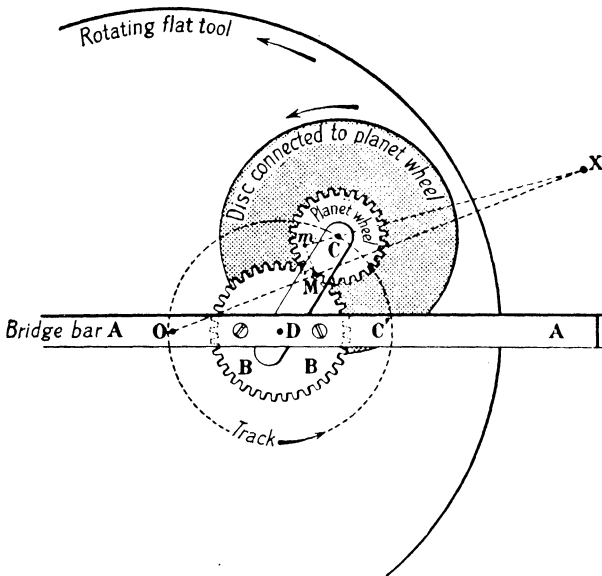

FIG. 55. Diagram of left-handed "valseur".

upon the planet wheel. The track described by the driving pin on the flat disc results then from one oscillatory movement and several circular movements; it is a complicated curly curve.

The radius of the satellite being  $r$  the maximum frictional couple is  $Fr$ . There will be a stoppage of the translation of the glass when the retarding couple is equal and opposite to the couple  $K$ . A condition for the working of the valseur is then  $Fr < K$ , whatever be the force  $F$ , which varies with the elongation.

The braking also varies constantly in intensity with the position of the satellite, but its effect varies to the greatest extent with the distance of the driving pin from the axis of the lathe. The braking couple being the moment of the force  $F$  in relation to the tooth in engage-

ment  $M$ , becomes a maximum at the same time as  $F$ , when the satellite is at its maximum displacement in relation to the axis of the lathe; at the same instant as the couple  $K$  attains its minimum value, the effect of the braking approaches a complete stoppage. Thus for a given "valseur" a displacement of some millimetres in relation to the axis of the lathe or a slight increase in the amplitude of oscillation has a very noticeable influence on the braking.

The maximum eccentricity of the driving pin increases with the radius of the pinion or of the toothed crown, with that of the planet

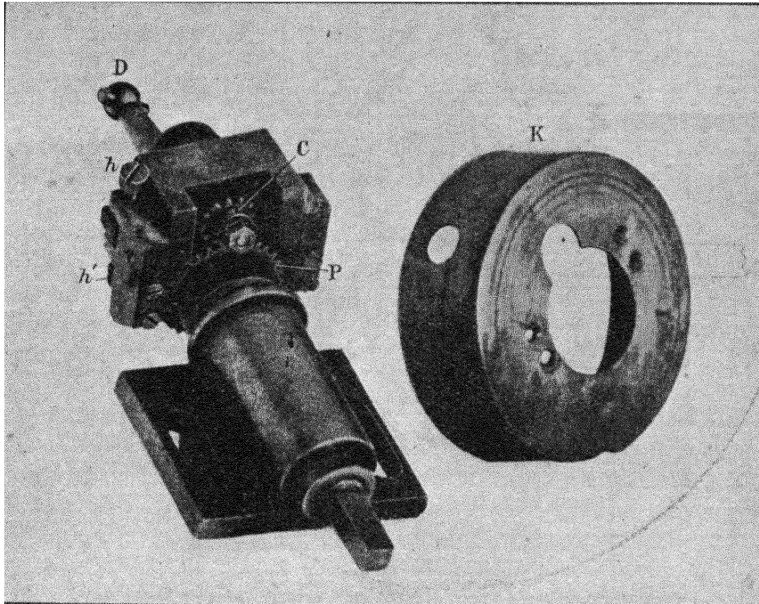

FIG. 56. Left-handed "valseur" with cover removed.

D = Driving pin with little bar. C = Planet wheel. P = Fixed pinion.  
K = Cover.

wheel and with the eccentricity of the driving pin on the planet wheel. Obviously more robust gears are required to drive a large block than a small one. On the other hand, the condition  $Fr < K$  forbids the employment of a planet wheel whose diameter exceeds  $\frac{1}{4}$  (or better,  $\frac{1}{5}$ ) of that of the glass.

But how is a choice to be made between the right-handed and left-handed valseurs? The layer of abrasive which passes beneath the glass and upon which the glass is displaced can be considered as a current. When the glass follows the current at the speed of the cur-

rent the driving pin does not support any resistance. If the glass advances in the direction of the current but more quickly than it, or if it advances against the current the driving pin suffers a resistance which the tooth in engagement transforms into a couple. This couple accelerates the rotation when the glass is displaced in the direction of the current but less quickly than it. That is the case of the right-handed valseur, which augments the speed of rotation when the planet wheel is at about its maximum extension.

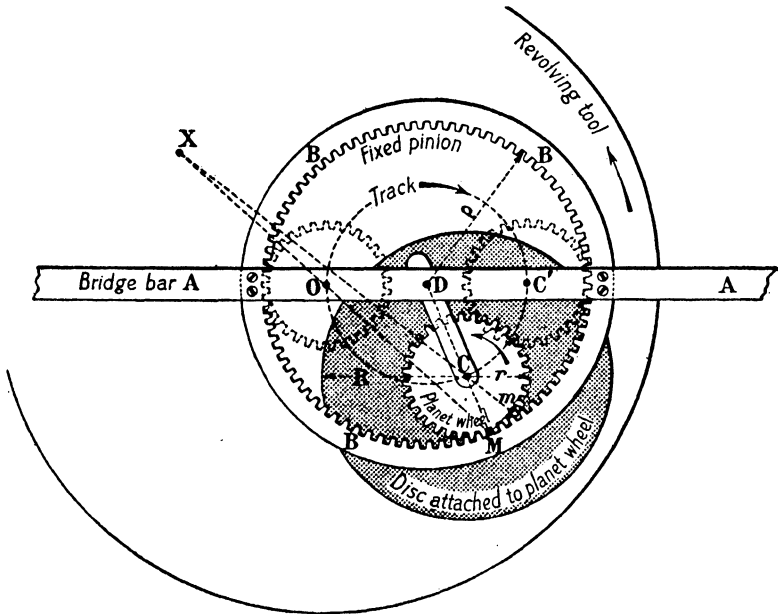

FIG. 57. Diagram of right-handed "valseur".

O and C' extreme positions of planet wheel C'. X, instantaneous centre of rotation on the revolving tool.

In the other cases the couple created by the current brakes the rotation.

Whether the normal speed of rotation of the glass is increased or diminished the effect is the same. The relative rotation of the glass in relation to that of the flat tool (or concave tool) on which it rubs is to the left in the first case and to the right in the second. Now the direction has no influence upon the wear. Nevertheless, when the glass overlaps, the overlap tends to slow up the rotation of the glass; the left-handed valseur tends, on the contrary, to increase that rotation, and there is a certain measure of compensation.

It is seen that left-handed valseurs are particularly suitable for surfacing blocks of plane or slightly curved glasses since they allow of greater overlap without slowing up the rotation too much. The position of the valseur being properly adjusted, as well as the amplitude of oscillation, in such a way as to obtain a suitable overlap, the speed of the piece connected to the valseur must exceed by four times the exact speed of the lathe during one revolution of the planet wheel. The variations of speed are then small and of the order of those provoked by the variation in humidity of the abrasive from one region to another, in other words, the system of equal wear is practically realised.

Right-handed valseurs which constantly brake the rotation are indicated for surfacing blocks of deeply curved glasses up to at least an aperture of  $140^\circ$ . But the same adjustment is not suitable for surfacing convex and concave glasses. In both cases, one must work in such a way that the instantaneous axis will be inclined at about  $35^\circ$  (see Fig. 53c) to the axis of the block of glasses, that is to say, to the axis of the lathe in the case of convex glasses or to the axis of the concave tool in the case of concave glasses; thus more braking must be applied for surfacing convex lenses. For this, in the case of convex glasses, greater eccentricity is used or the amplitude of oscillation is increased a little if it is possible to do so without overlapping too much.

Some very curved blocks can thus be surfaced rapidly on an ordinary automatic lathe without requiring recourse to the practice of relieving (cutting away) the polisher to correct the too rapid wear in the centre of the block. Now, this too rapid wear is produced principally in the smoothing; one is obliged to make up for this difference of wear during polishing by relieving the polisher a great deal and several times. The right-handed valseur then really fulfils a need.

Both types of valseurs having the property of greatly increasing the length of the track developed by the driving pin on the piece mounted on the lathe, surfacing with a valseur bears a great resemblance to hand work on a fixed tool post in which the rubbing is obtained by translation on curled trajectories.

This advantage of the valseurs is the only one which is utilised when they are employed on a lathe with adjustable relative rotations. It is for this use that the axis of the fixed pinion is terminated by a squared end (Fig. 56) destined to slip into the socket on the end of the flexible drive, which is then charged with the duty of maintaining the speed of rotation of the planet wheel at a desired value by imposing on its crank the rotation of the flexible drive. This procedure permits adjustment of the braking as is desired without increasing the eccentricity of the valseur or the amplitude of its oscillations, which

cannot usually be done without overlapping too much. The usual surfacing lathes do not offer this resource.

**SYSTEMATIC MODIFICATIONS OF A SURFACE BY THE AID  
OF A LATHE WITH ADJUSTABLE RELATIVE ROTATIONS.  
LOCAL RETOUCHING. ASPHERICAL SURFACES**

Figs. 53*a* and *e* show the extreme means at the optician's disposal for mechanically deforming a surface, either if he wishes to wear away the central region or if he wishes to obtain the reverse result.

The regime  $\gamma = 20^\circ$  (Fig. 53*e*) permits wearing away the marginal zone ( $\beta = 70^\circ$  approximately) twice as quickly as the central region.

The regime of ordinary automatic machines produces almost the reverse of this effect.

If a block has been deformed by surfacing on an automatic lathe, it is possible to restore it to a proper curvature by continuing the surfacing on a lathe with adjustable relative rotations adjusted to realise  $\gamma > 20^\circ$ .

Opticians who have no such lathe at their disposal can remedy matters by braking the rotation of the concave tool with the hand; but this practice although efficacious, is uncertain, for one can brake too much, or too little or irregularly.

Figs. 53*a-e* show the resources offered by the lathe with adjustable relative rotations for executing, on the whole of a surface, systematic deformations of revolution by working the surface without uncovering it, that is to say, with a tool larger than the surface, oscillating without overlap. The most frequent case, on the contrary, is that of local retouching carried out with a tool smaller than the glass. This also is the case of the working of aspherical surfaces only slightly different from the sphere.

Where local retouching or the formation of an aspherical surface is concerned, the starting point is an exact knowledge of the topography of the trued surface. Thereafter the optician must follow the progress of his work step by step by interferential observations (see Chapter VI).

**The case of a Tool smaller than the Glass but covering its Centre**

Let us now examine the differences in effect accordingly as the tool turns freely (ordinary automatic machines) or it is prevented from turning (hand work). It will be supposed, for simplification, that the centre of the tool is kept stationary.

If the tool turns freely, the circle constantly covered is worn uniformly when surfaces of slight curvature are concerned (Fig. 23); it is slightly concave if the surface is curved. On all the concentric rings which start from the tool the wear is proportional to the arc covered

by the tool. The surface tends to take the form of a basin with a flat bottom; the ordinary automatic lathe adjusted with a small oscillation cannot produce any other shape.

The tool being prevented from turning the wear on each ring of the glass is proportional to its diameter and to the length covered by the tool. From this it results that the flat bottom seen above is replaced by a central conical elevation and the part of the basin which is most hollowed out is not far from its edge (Fig. 23). This law is very little modified if the worked surface is curved. Work on a treadle lathe with a screwed tool-knob cannot produce any other form unless the effect of the displacement of the knob does not outweigh the effect of the rotation of the slowly turning lathe. The optician working a glass larger than his tool on a treadle lathe must expect to form a central elevation. He can avoid it by replacing his screwed knob from time to time by a ball-and-socket handle, a practice which is insufficiently employed.

According to this, to remove an elevation, it suffices to work with a freely turning tool without uncovering the elevation. To efface a central basin, work with a strongly braked tool, that is to say, with a small value of  $\gamma$ . The choice of that small value of  $\gamma$  is not generally indifferent. The ring which is traversed by the instantaneous axis of rotation is a place of minimum wear, as is indicated by the turning point which is seen in all the curves of Figs. 53*a-e*. Making the instantaneous axis pass through a ring which must be worn less than its neighbours is then indicated. This can only be done on a lathe with adjustable relative rotations. The shading off of the limits of wear is increased by the oscillatory movement of the tool which must oscillate between the two edges of the trough to be hollowed out.

Between the system with the freely rotating tool and that with the tool which does not turn, there are all the intermediate systems corresponding to the various values of  $\gamma$  between zero and  $90^\circ$ . By realising a suitable angle  $\gamma$  on a lathe with adjustable relative rotations the "thalweg"\* of the trough hollowed out by a tool smaller than the glass can be placed wherever one wishes. In the case under consideration it is the vertex of the glass which must be worn away, but the most projecting part need not be the vertex. Verification by interference (Chapter IV) will show the angular aperture of the most projecting ring, *i.e.* the angular aperture of the "thalweg" to be hollowed out.† If, for example, it is necessary to remove a thickness of  $1 \mu$  at

\* Thalweg is the line of greatest slope of the floor of a valley. (Trans.)

† In other words, the test plate will show the position of a "high" ring which must be compensated by a setting of the lathe tending to produce a "low" ring of the same radius, supposing the fault to be symmetrical about the centre of the lens. (Trans.)

the vertex and of  $1.5 \mu$  at the "thalweg" of aperture  $2 \mu$  the ratio of wear  $U$  (pp. 150 and 151) will be 1.5. By inserting that value of  $U$  and the value of  $\beta$  in the equations on p. 151 the angle  $\gamma$  will be defined, nearly the right value of which may be obtained by trial. The first of the two equations will be the proper one if it is satisfied by a value of  $\gamma$  smaller than  $\beta$ . In the contrary case it is only the second equation that should be considered. It should not be forgotten that these equations suppose the "thalweg" to be constantly entirely covered by the tool. Since the case under consideration supposes the tool to be smaller than the glass the values of  $U$  found for the margin which is not constantly covered must be reduced.

#### The case of a Tool smaller than the Glass and not covering the Centre

This is the case of the tool  $C_2$  in Fig. 22. That figure shows the curves of wear in the two limiting cases (the case of the freely rotating tool and the case of the completely braked tool). The fact that the worked surface is curved instead of being plane does not alter the general slope of the profiles of wear.

From the moment that the tool ceases to cover the centre of the glass its angular aperture is small, and the case of spherical surfaces can be legitimately assimilated to the analogous case of plane surfaces. If the induced rotation of the tool is braked to a greater or less extent the "thalweg" gets nearer to or farther from the centre of the glass.

In all cases, for the execution of local retouching a fairly malleable polisher should be used in order that it may mould itself on the mean profile of the trough which it hollows out.

### DETERMINATION OF THE OPTIMUM POINT AT WHICH A FORCE MUST BE APPLIED IN ORDER TO PRODUCE A TRANSLATION OF A GLASS CARRIER (BLOCK) OR OF A TOOL

#### Plane Surfaces

Let us consider a plane glass resting on a flat tool and exercising a pressure  $P$  on it due to an added weight (Fig. 14). In order to make the glass, thus loaded, slide on the flat tool it is necessary to overcome a certain frictional resistance  $F$  which is very closely proportional to

$P$ . The ratio  $\frac{F}{P} = f$  is called the coefficient of friction. There are

tables which give the values of  $f$  for various bodies in contact, and these values differ a little according to whether friction at the commencement of motion is concerned or friction during movement. For cast iron sliding on slightly greased bronze  $f = 0.15$  about. No value of  $f$  can be assigned for the operations of surfacing. If a very liquid paste has been put on the tool a little too abundantly the value of  $f$  is almost

nil. If a thin layer of abrasive paste has been allowed to dry, the tool sticks to the glass and the value of  $f$  may exceed all limits, since, without exercising vertical pressure a considerable effort must be made to unstick the glass.

In regular work, the value of  $f$  does not depart much from unity; its exact value depends on the state of the abrasive layer at the chosen moment. If  $F$  is the frictional force at that moment, an equal and opposite force  $F'$  must be opposed to it in order to displace the glass. The force  $F'$  combines with the pressure  $P$  and the resultant  $OR$  is determined by  $P$  and by  $f$ . If the pressure  $P$  is increased, the frictional resistance increasing proportionally to the pressure, the slope of the resultant  $OR$  does not vary. If the ball point of a driving pin could be fixed at the point  $O$ , movement would commence as soon as the horizontal effort of the driving pin attained the value  $F$ , and that horizontal effort combined with the weight of the glass and the added load, would give the resultant  $OR$ , which being applied at the centre of the glass would ensure an even distribution of the pressures over the whole surface. As it is materially impossible to place the ball point at the point  $O$ , it is placed higher up; the horizontal effort of the pin combining with the vertical pressure gives an oblique component which does not pass through the middle of the glass and as it is no longer possible for the distribution of the elementary pressures to be symmetrical, the region which is foremost in the direction of displacement presses the most and is therefore the most worn. If the socket were formed in the screwed knob instead of being hollowed out of the threaded boss of the tool or the lens carrier, the "edge off" effect would be considerable. To reduce this danger, in hand working use should be made of very large knobs because when one pushes on such a knob with the palm of the hand, the oblique force, which simultaneously replaces the horizontal force of the driving pin and the pressure of the additional load, cuts the surface of the glass nearer to the centre than if the knob were small.

In the foregoing it has been implicitly supposed that the flat tool on which the glass slides was immobile. If the flat tool turns, the glass guided by a central driving pin assumes, as has already been explained, the same rotation as the flat tool. That is to say, it turns about itself with respect to the workshop but does not turn in relation to the tool. All the considerations of the previous case apply, then, on condition that the forces and speeds are related, not to the workshop, but to the flat tool. Thus the value of the force borne by the driving pin is not changed, the slope of the straight line  $OR$  is not modified, nor, in consequence, is the distribution of the pressures.

### Spherical Surfaces

For working spherical surfaces it is just as important, and more difficult, to determine the optimum point at which it is suitable to apply the force producing the translation of the glass on the tool, or vice versa. Let us consider a very deep concave tool resting upon a hemispherical ball on which it exerts a certain vertical pressure. Let

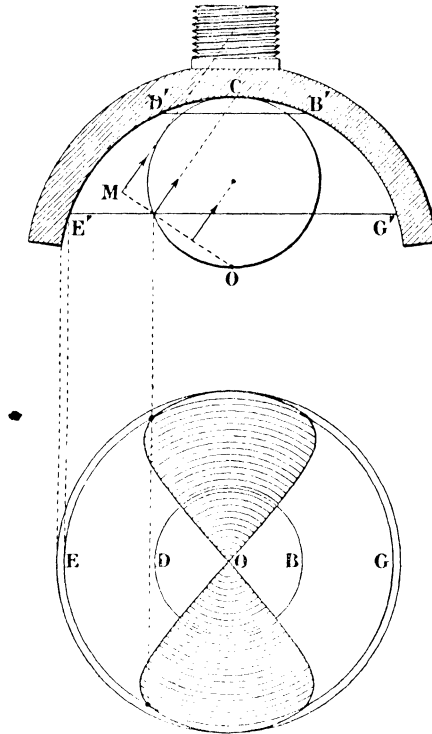

FIG. 58.

us suppose that the concave tool is made to slide on the convex one by making it turn around the diameter projected through  $O$  in the elevation of Fig. 58. All the frictional forces are perpendicular to the normal dropped from the point rubbed on to the diameter  $O$ ; hence they are parallel to the plane of the paper. The forces coming from a point exterior to the circle constructed on the radius  $OC$  as diameter in a vertical projection, pass above the point  $C$ , and all the forces coming from a point inside the same circle pass below the point  $C$ . The circle  $OC$  represents the section of a cylinder which passes through

the sphere separating there, on the one hand, the regions for which the directions of friction pass above the point  $C$ , and on the other hand, the regions for which the directions of friction pass below the point  $C$ . Seen in a horizontal projection the curve of separation presents the shape of a figure eight, and shows that, for a shallow concave tool, such as  $DB, D'B'$ , the regions considered are appreciably equivalent. On the contrary, for a large concave tool, such as  $EG, E'G'$ , the regions for which the frictions pass above the point  $C$  predominate. A simple glance at Fig. 58 shows that the resultant of the friction must be very little above the point  $C$  for concave tools of the usual dimensions and a little higher for very deep concave tools. Indeed, the regions of the sphere which are the seats of frictional forces directed below the point  $C$ , and which are shaded in the figure, are not much smaller than the unshaded regions, seats of frictional forces directed below the point  $C$ .

A calculation based on the hypothesis of an even distribution of pressures indicates that the point of application of the frictional forces is sensibly merged with the point  $C$  so long as the aperture of the concave tool does not exceed  $120^\circ$ . The distance to the point  $C$  does not exceed  $\frac{1}{2}$  of the radius for a  $180^\circ$  concave tool. But this calculation supposes the pressure to be uniformly distributed over the whole surface of the concave tool, which is never realised; the pressure decreasing very much towards the edges of the tool, that is to say, in the regions where the frictional forces are most elevated. The distance to the point  $C$  from the point of application of the resultant of the frictional forces is still less than is indicated by the calculation.

The point of application of that resultant is, then, inaccessible in practice, and, moreover, it would not be useful to attain it for guiding a concave on a convex tool, for to work a curved surface one must depart from the rules proper to the surfacing of planes and find an artifice for compensating the lack of pressure towards the edges. The artifice which suggests itself is to guide the concave tool by a point situated a little above the point  $C$ , the result of which is to render the zone of maximum pressure eccentric.

Let us consider a concave tool sliding on its convex tool by turning about a diameter projected through  $O^*$  (Fig. 59) and, on the concave tool, two points  $A$  and  $B$  symmetrical with respect to the medial plane containing the axis of sliding,  $O$ . It has been seen above that the direction of the resultant of the pressure, and of the friction in a chosen region, is independent of the pressure and only depends on the value of the coefficient of friction at the moment. If  $CA$  is that direction for the point  $A$ , the slope  $\alpha$  with respect to the normal is the same for the element of surface  $A$  as for the element of surface  $B$ . The resultant

\* Perpendicular to the plane of the paper.



the concave tool will be located towards the edge situated in the direction of movement.

It has been seen in Chapter III *à propos* cylindrical surfaces (p. 83) how this divergence of the region of maximum pressure can compensate the natural unevenness of distribution of pressure on a curved surface, on condition that a pressure very little above the minimum useful pressure is exerted.

The introduction of the rotation of the tool during the displacement of the glass alters nothing in the foregoing considerations. The reasons for it have been set forth *à propos* of the displacement of a plane glass on a flat tool; they are the same for curved surfaces.

## CHAPTER VI

### OPTICAL TESTS IN THE WORKSHOP

#### Surface Tests

The precision mechanic works to the hundredth of a millimetre, and his workshop testing instruments (vernier calipers, micrometers, templates, slip gauges) permit the exact appreciation of the hundredth of a millimetre.

The optical worker, who works to the test plate, needs to appreciate the tenth of a fringe, *i.e.*  $\frac{1}{50000}$  mm. Put in other words, he must work with a precision five hundred times as great as that which suffices for the mechanical worker. This figure is impressive; nevertheless, the optician has hardly any more trouble in working to  $\frac{1}{50000}$  mm., with testing methods which make this small dimension clearly visible, than he would have in working to the hundredth of a millimetre with mechanical means of test. As soon as the surfaces to be tested commence to be sufficiently polished the use of the test plate allows of the appreciation of  $\frac{1}{50000}$  mm.

Smoothing can only give an approximation; a commencement of polishing is necessary to permit judgment of whether that approximation is sufficient, and when it is not, the appearance of the fringes shows in what way the surface must be retouched by modifying the conditions of a fresh smoothing operation.

Thus, test-plate working allows of taking as a unit of measurement of surface errors, not the millimetre nor the micron ( $\frac{1}{1000}$  mm.) but the half wavelength, *i.e.* about a quarter of a micron. This so precise element of measurement is borrowed from the constitution of light itself. The wavelength of light is designated by the Greek letter  $\lambda$  (lambda), the micron by the Greek letter  $\mu$  (mu) and the usual unit for optical testers is  $\frac{\lambda}{2} = 0.25 \mu$  (approximately), the exact figure varying with the colour of the light used.

#### Light

Light is the effect of a certain system of vibrations which are transmitted in vacuum with the velocity of 300,000 km. per second (in round figures) and at slightly lower speeds through transparent bodies.

What vibrates? The answer to that question would be complicated but would not interest the optical worker. It is sufficient for him to know that the lengths which characterise these vibrations are very

exactly measured. To form an idea of the vibratory system which constitutes light one is obliged to have recourse to rough comparisons and to study examples of vibratory movements which are familiar.

A tuning fork and the string of a musical instrument are examples of vibrating bodies. Their vibrations transmit themselves to the surrounding bodies. The table on which the tuning fork is rested vibrates also, for it increases the intensity of the sound of the fork. The flapping of fly's wings in flight makes vibrations producing a hum. The air which transmits the sound of the violin or the hum of a fly vibrates like the violin. The vibrations of the violin string are seen but not those of the air; one can, however, form an idea of them by watching the transmission of vibrations in water. If the fly falls on to the surface of still water the flapping of its wings is seen to produce little concentric waves which are propagated with a constant velocity. When these waves are cut by a wall, or by a vertical plank rising from the water, one can see the profile of the waves on that wall or plank. These waves are the image of light waves; they are composed of a swelling followed by a depression and so on, in series. The speed of displacement of a wave can be followed. If  $v$  is the length through which it passes in 1 second and  $N$  the number of flaps of the fly's wings in 1 second,  $N$  waves per second are seen to pass, advancing with a velocity  $v$ . In the length  $v$ , then, there are  $N$  waves or undulations, consequently the wavelength is  $\frac{v}{N} = \lambda$ .

It is the same for light; but for light the figures which must be inserted in the preceding formula are either prodigiously large or small.

$$v = 300,000 \text{ km. per second about.}$$

$$\lambda = \begin{cases} 0.77 \text{ microns for red light} \\ 0.59 \text{ ,, ,, yellow light} \\ 0.43 \text{ ,, ,, violet light.} \end{cases}$$

From which one deduces the number of vibrations per second.

$$N = \frac{v}{\lambda} = \frac{300,000,000,000,000}{(0.77 \text{ or } 0.59 \text{ or } 0.43)} = \text{about } 600 \text{ trillions.}$$

Thus the number of vibrations is greater or less, according to the colour, and the wavelengths vary inversely. Faced with these figures one must admire the perfection of our eyes, which distinguish an infinity of nuances between red and violet.

### Interference of Light

Let us again take the example of the waves in the water. Let us suppose that two flies fall into the water, one at  $A$  and the other at  $B$

(Fig. 60), and continue to flap their wings in cadence. A series of circular waves emanates from *A* and another series from *B*; these waves are seen to cut and penetrate one another without deforming.

There are, on the surface of the water, lines of points where the swellings of the waves meet one another and add together. There are other lines of points where the depressions of the waves cut one another forming a more pronounced depression. Finally, there are lines of points where the depressions of waves issuing from *A* encounter the swellings of the waves issuing from *B*. At these points there is a compensation and the water remains at the original level of the still water.

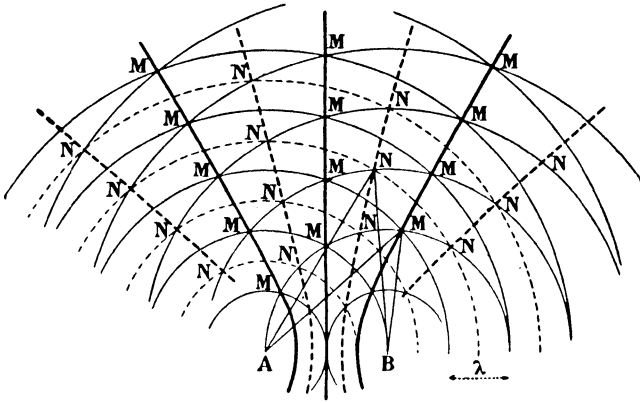

FIG. 60.

The waves are said to interfere at these points and the lines which these points form are said to be interference fringes.

In one wavelength  $\lambda$ , there is a zone of swelling and a zone of depression; these zones have, then, the length  $\lambda/2$ . On considering Fig. 60 it is seen that there is interference at a point when the distances of that point from the wave sources *A* and *B*, *i.e.* the rays issuing from *A* and *B*, differ by an odd number of  $\lambda/2$ .

The wavelength is represented in this diagram by 8 mm. The interference lines are the hyperbolæ marked *NNN* . . ., the hyperbolæ marked *MMM* . . . are the lines of swelling or of depression. On the first the amplitude of vibration is nil; on the second it is a maximum. All the points *M* are characterised by the fact that the difference of the radii *AM* and *BM* is an even number of half-wavelengths; on the other hand, the difference of the radii *AN* and *BN* is an odd number of half-wavelengths.

Thus, in water, the interference curves are the places where the upward movements of the water are destroyed by the downward move-

nents. It is the same in the case of luminous vibrations. Radii of uminous waves are luminous rays; when there is, between two rays, path difference of an odd number of half-wavelengths the vibratory movements are contrary to one another, and the places where the vibratory movements destroy one another are thus dark places. It is observed, indeed, that the interference fringes are black, when they are observed by monochromatic light. In white light, they appear with all the colours of the rainbow, hence the expression "to work in colours"\*. The reason for that appearance is as follows.

Fig. 60 having been made by supposing the wavelength to be represented by 8 mm., if it is supposed that that length corresponds to red light, and if one wishes to superimpose on that diagram an analogous diagram for yellow light and another for violet light, it will be necessary to trace a network of full circles 6.8 mm. apart for yellow light and .7 mm. apart for violet light. One would then find other interference lines, fairly well separated from one another in the neighbourhood of the sources *A* and *B* and more and more superimposed and intermingled at greater distances. This proves that in working with white light the fringes can only be observed when they result from a path difference of a small number of  $\lambda/2$ ; one has much greater latitude when working in monochromatic light.

If *A* and *B* represented two point sources of light sufficiently close on an angular separation for them to appear to be one, and vibrating synchronously, an eye placed on any one of the hyperbolæ *MM* . . . would see a bright point. If the eye were displaced, it would see the brightness of the point diminish and then become extinguished at the moment when the eye crossed one of the hyperbolæ *NN* . . . . During this displacement the observer would have the impression of seeing an occulting lighthouse light.

Some interference phenomena are commonly observable. Who has not admired the brilliant colours of a soap bubble or of a spot of oil on water in the sunshine? This effect of coloration is produced by the interference of luminous rays reflected, some from the first surface, some by the second face of the thin plate which is constituted by the film of soapy water of the bubble or the layer of oil on the water. Here is the explanation of that phenomenon.

For better generalisation, let us consider a transparent plate limited by two curved surfaces (Fig. 61). Let us suppose, further, that this plate is a thin plate of air between two glass surfaces.

Each point of the upper surface of this plate receives diffused light coming from different directions. It reflects and diffuses it in its turn in numerous directions. Any point *A*, then, can be considered as a

\* Since this expression is not in common use in English practice it has everywhere else been translated by the more familiar "working to the test plate". (Trans.)

point source of light. Let  $MM$  be a wave issuing from the point  $A$  at a given instant; to this wave belongs a pencil which penetrates to the interior of the plate and contains a ray  $AB$ . This ray is reflected at  $B$ , refracted at  $C$ , and goes out towards the eye at  $X$  (not shown) in the direction  $CX$ . Now there is a pencil belonging to the same wave  $MM$  issuing directly from the point  $A$  towards the eye and very close to  $CX$  because the plate is very thin. An eye observing the point  $A$  can receive both pencils, which vibrate synchronously at the moment of their emission but which have suffered a difference of path of  $AB + BC - AN$  ( $CN$  being an element of the surface of the wave  $MM$  when it has reached the point  $C$ ). If that difference of path is equal

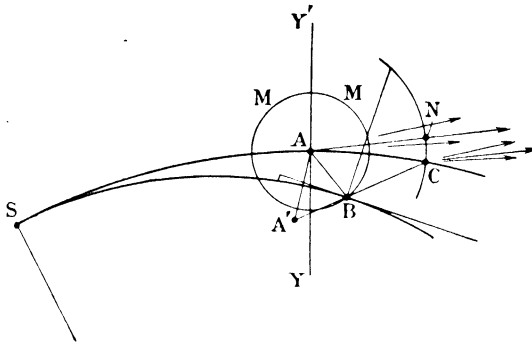

FIG. 61.

to a half-wavelength  $\lambda/2$ , or to an odd number of half-wavelengths, the two pencils interfere and the light is extinguished. If the path difference is equal to an even number of half-wavelengths the two pencils reinforce one another. The eye locates, around the point  $A$ , a dark spot in the first case and a clear spot in the second case. The value of  $AB + BC - AN$ , depends at once upon the obliquity under which the eye looks at the plate and the thickness of the plate at the point  $A$  under consideration. As the variations of thickness alone are of interest, obliquity of view is eliminated by always examining interferences normal to the plate.

The geometric locus of the points  $A$  for which  $AB + BC - CX = \lambda/2$  is a dark band which is the first dark interference fringe (in monochromatic light).

The locus of the points for which  $AB + BC - CX = 3\lambda/2$  is the second interference fringe, and so on.

Thus if one looks at the fringes under normal incidence, the thickness of the plate varies by  $\lambda/2$  (say about  $0.28 \mu$ ) from one fringe to the neighbouring one.

One can observe the fringes under normal incidence either by reflection or by transmission. In the latter case (Fig. 61), an eye placed in the direction  $AY$  receives a direct ray  $AY$  at the same time as a twice reflected ray almost superimposed on  $AY$ . There will still be many interferences between the direct ray and rays reflected 4, 6, 8 times, etc., in the thin plate, but they are more difficult to observe. The point  $A$ , not being a true light source, only emits the light which it receives. Now, at normal incidence, the ray  $Y'AY$ , which passes through, possesses about 96 per cent of the intensity of the incident ray, while the ray doubly reflected towards  $Y$  has only 4 per cent. of the intensity of the incident ray. The fringes seen by transmission are, then, washed with direct light. In practice one observes the fringes by reflection.

It may be noted that the ray  $BC$  seems to emanate from the point  $A'$  symmetrical with  $A$  in relation to the lower surface of the thin plate, in such a way that everything occurs as if there were two synchronous luminous sources, very close to one another, the one at  $A$  the other at  $A'$ , thus relating this case with that of Fig. 60.

If, instead of considering a thin plate of air, one considers a thick plate, and moreover, a plate of transparent material of refractive index  $n$ , the theory set forth above must be a little modified by taking note of the following laws.

*1st.* In a medium of refractive index  $n$ , light is propagated less quickly than in air and the ratio of the velocities is  $1/n$ . On account of this, for a geometrical path difference equal to  $AB + BC - AN$  the difference of optical path is  $(AB + BC)n - AN$ .

*2nd.* A ray traversing a transparent medium and being reflected on a second transparent medium suffers a retardation of a half-wavelength when the second medium is more refringent than the first.

It is indispensable to observe these laws if one wishes to utilise the fringes not only for studying the variations in thickness of the plate but for measuring its thickness at a point.

When the thickness of the plate is not very small the points  $A$  and  $A'$  can only appear very close in angular separation in directions close to the normal to the plate at  $A$  or at  $A'$ . It is, then, always necessary to observe the fringes in thick plates normally (as in testing plates with parallel faces).

If the transparent plate (Fig. 61) is a plate of air contained between two glasses touching with perfect contact at  $S$ , the point  $S$  appears dark when seen by reflection and clear by transmission. Thus fringes in monochromatic light, seen normally by transmission or by reflection, are the inverse of one another; fringes which are light in the first case appear dark in the second.

The law stated above allows the zero position to be sited in the scale

of thicknesses which the fringes constitute. Zero is on a black fringe in the scale of fringes seen by reflection.

To observe the fringes at normal incidence, it suffices (Fig. 62) to illuminate the glass and the test plate by means of a piece of white cardboard inclined at  $45^\circ$ , pierced with a hole the size of a pencil and to look through this hole. Thus, if a very slightly convex lens is rested

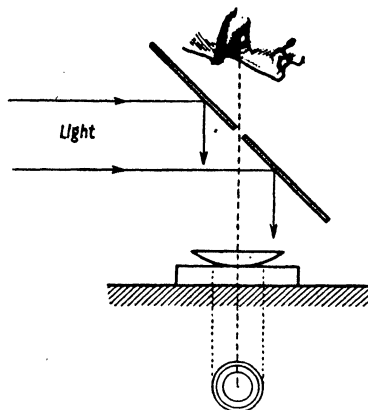

FIG. 62.

on a proof plane, there is created between the lens and the proof plane a thin concave plate of air which produces interference effects, and around the point of contact are seen a certain number of rings which may extend right to the edges of the glass. If, while observing quite normally, ten rings (for example) are counted it shows that the sag of the surface at the largest ring is equal to  $10\lambda/2$ , that is, about  $2.5\ \mu$ .

When the fringes are seen at oblique incidence the rings are coloured because, exactly as in the case of Fig. 62, there is a network of rings for each colour. The red rings have not the same diameter as the yellow or violet rings of the same order, with the result that beyond a small number of rings the overlapping of the colours is such that white light is reconstituted and the interference effects are no longer visible. The use of monochromatic light will render them visible and then the phenomenon is exhibited with a plate several millimetres thick.

Without employing absolutely monochromatic light there is great advantage in using a fairly bright light which is nearly so. Mercury lamps (Fig. 63) are excellent for making fringes visible, so that they even appear without the glasses being completely in contact, thus diminishing the danger of scratching the glasses in putting them down

on the test plate or proof plane. It is for this reason that optical workshops should be lit with mercury lamps.\*

The interpretation of the fringes demands some attention. There is less chance of interpreting them wrongly if white light is used, for,

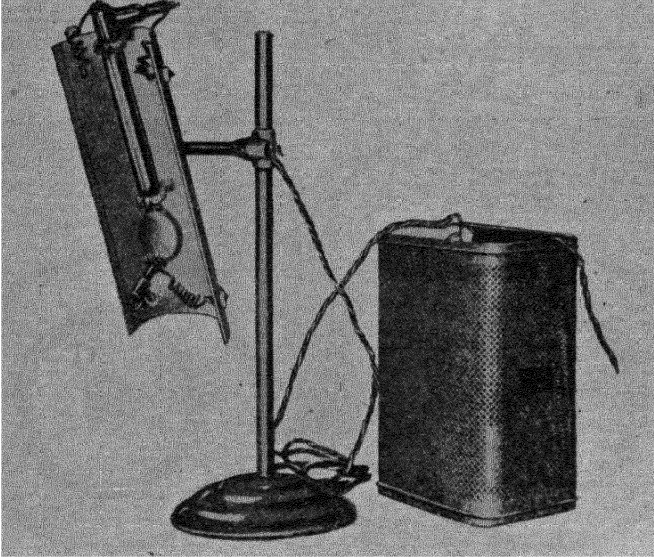

FIG. 63.

in this case, there are two criteria available; the order of the succession of colours and the direction of displacement of the fringes under the pressure of the fingers. The second criterion is, naturally, the only one when one works with monochromatic light.

When observation is made in white light, the thickness of the plate of air which separates the two surfaces in contact increases in the direction in which the succession of colours is violet, blue, yellow, red.

An even tint indicates that the thickness is the same throughout the surface which it covers. It is sensibly so in the neighbourhood of points or lines at which the two surfaces are tangential.

If one observes three blue rings and four red rings, it can be estimated that there are about three and a half fringes.

The fringes spread themselves out under pressure of the fingers in the region in which the relative inclination of the two surfaces diminishes. They always spread out by moving *away* from the point at which they are really in contact. When a glass is presented to its

\* Suitable lamps are obtainable from the Hewittic Electric Co., Sunbury-on-Thames. Low pressure lamps are better than high pressure ones. (Trans.)

test plate the shape of the rings and their deformations under pressure from the fingers indicates the nature of the retouching to be performed. If the glass touches the test plate at the middle one sees the rings

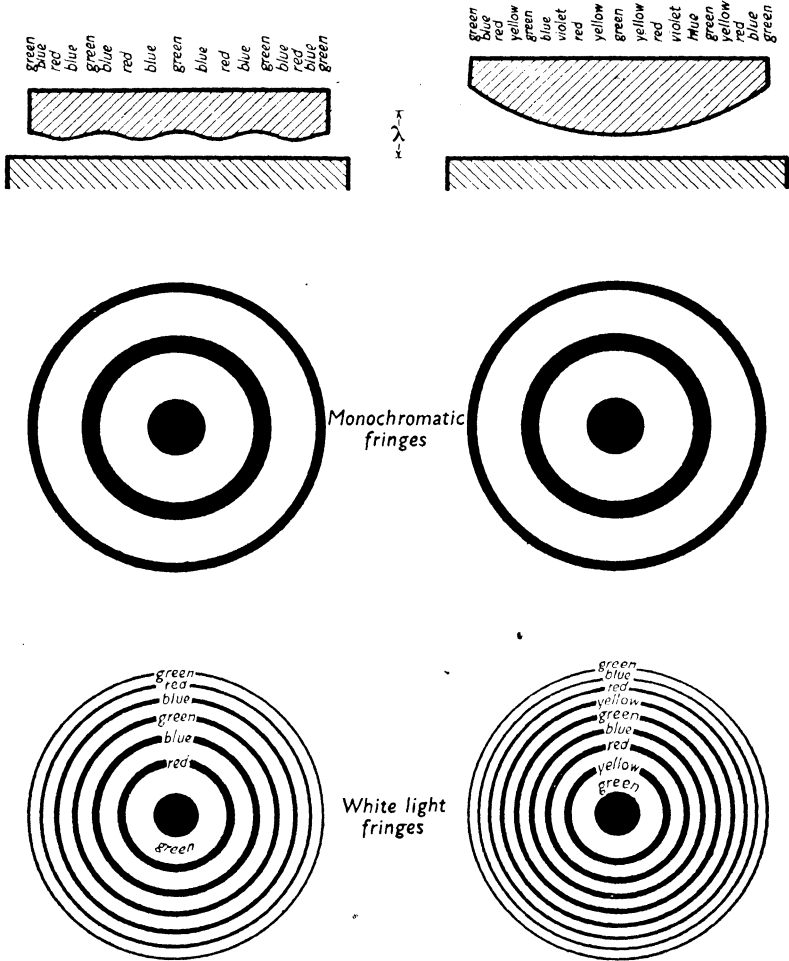

FIG. 64. Difference of contours which cannot be discerned by means of monochromatic fringes.

grow larger when the edges of the glass are pressed. If the glass touches the test plate at the edges, one sees the rings get smaller in diameter when one presses on the middle of the glass.

Fig. 64 shows an exceptional example of the advantage of white

light over monochromatic light for the interpretation of fringes. It represents the sections of two discs. The centres of each of them are at a distance of  $\lambda/2$  from a proof plane,  $\lambda$  being the wavelength of the mercury green line (5461A).

The left-hand disc presents an imperfect plane surface having a slight central depression, a trough a small fraction of  $\lambda$  deep and with the edge "off".

The right-hand disc presents a regularly convex surface which gives a central green spot and two green fringes corresponding respectively to  $\lambda/2$  and  $3\lambda/2$ , while the fringes of the left-hand disc all correspond to  $\lambda/2$ .

In coloured (monochromatic) light the two discs present fringes of the same appearance. In white light, on the contrary, the coloured fringes are not the same on both discs. The green fringes come between blue fringes on the left-hand disc and between a yellow fringe and a blue fringe on the right-hand disc.

In general, symmetry of the colours reveals shallow concentric hollows.

To sum up, monochromatic fringes constitute very sharp contour lines of the surfaces; they can be very numerous, but they bear no distinguishing indications. Fringes produced by white light are less sharp than monochromatic fringes, cannot be numerous, but give an indication of the direction of the slopes, for in the descents the colours follow one another in the order fixed by the famous jingle.

Violet, indigo, blue, green, yellow, orange, red.

When a plane glass is placed upon a proof plane the fringes are straight. They can be very numerous and close together, that is when the interposed plate of air is prismatic. By pressing them together, the fringes are spread out and the further they are spread out the better can one appreciate the slight sinuosities of the fringes caused by local defects. Thus, if one of the sinuosities has the value of  $\frac{1}{5}$  of a space, it shows that at that place there is a departure from level of  $\frac{0.28\mu}{5} = 0.056\mu$ .

When the interval between two consecutive fringes exceeds the dimensions of the piece to be verified, it is said that an even tint has been obtained, *i.e.* perfection.\* By perfection, it must be understood that the piece to be compared is exactly superposable on the

\* At this instant, the adhesion of the two pieces is often so great that there is a risk of scratching them in making the effort of separating them, but it will suffice to pass the flame of a blow lamp along the edge of one of the dihedra formed by the two pieces in order for expansion to separate them.

[Unless the "tint" is black (*i.e.* the plates in optical contact) this will not be necessary. If the top plate is held up the weight of the other is nearly always sufficient to pull them apart. (Trans.)]

test plate in the position in which it has been placed. But it may happen that, after having slid it on the test plate, it is no longer possible to observe the even colour in the new position, in that case the test plate is not spherical. One has, then, a convenient means of detecting this.

When the fringes are neither straight nor circular the surface is defective; with a little practice and thought the above rules permit the easy interpretation of the irregularities of the fringes.

The verification of optical surfaces by the examination of interference fringes was introduced into workshop practice about half a century ago by the French firm of Laurent (to-day Messrs. Jobin et Yvon)\*, who constructed the first interferential testing appliance for the workshop for the control of plane surfaces. Makers of precision optical instruments later adopted the method of surfacing with verification by the fringes. That is what is known in the works as "working with colours" (Anglice "working to the test plate"). The foreigner has not neglected to follow the example set by the French firm.

### Test Plates and Surfacing by the Number of Fringes

The establishment of dimensional templates is at the basis of all precision manufacture. More particularly, for the construction of optical instruments the establishment of templates (or test plates) of curvature must precede the commencement of the actual manufacture.

Test plates are only made in pairs, a male and a female test plate, both of the same curvature, in order to verify the one by the other. If they are truly spherical, as they should be, the convex test plate placed on the concave test plate should give, at the most, one or two properly circular rings of constant appearance whatever the relative position of one test plate with respect to the other. Further, they give an even tint, *i.e.* less than one ring, if the two curves are of exactly the same curvature. The length of the radius of curvature is measured with special laboratory instruments which can give an approximation of a micron on radii less than 10 cm.; an approximation which is only significant when the sphericity is perfect.

It is rarely that a test plate of exactly the desired value is obtained at the first attempt, it is usually a little too small or too large. When the error in value has been made known by the laboratory measurements it is for the workman to retouch his pair of test plates. To this end, if the value realised is too small the workman retouches the concave test plate by reducing its curvature in such a way as to make it

\* This has also been attributed to Fraunhofer, see Twyman, *Prism and Lens Making*, p. 7. (Trans.)

give a certain number of rings at the centre of the convex test plate. If, on the contrary, the value realised is too great, it is the convex test plate which is retouched to increase its curvature. When, finally, one of the test plates is of the desired value the other is retouched to adjust it to the first. But the workman must know the number of fringes that he must cause to appear to correct the error in value. We shall see later how this number is found with various types of proof planes or spheres.

The thickness to be given to the test plates must be such that the flexure to which they are subjected in their manipulation will be so small that neither the perfection of their surfaces nor their curvature will alter. The thickness to be chosen is theoretically dependent on the diameter through a fairly complicated relationship, but so long as a diameter of 35 cm. is not exceeded the following rules can be employed.

The thickness at the centre of a plane test plate (proof plane), or a convex one, must at least equal the diameter divided by 5.5. The same applies to the thickness at the middle of a concave cylindrical test plate. The thickness at the edges of a convex test piece should at least equal a twentieth of the diameter, and so also should the thickness at the centre of a concave spherical test plate.

The material chosen for making the test plates should have a very small coefficient of expansion, in order that they shall be but little sensitive to variations of temperature or to the warmth of the hands manipulating them. Pyrex or Sibor glasses appear to be indicated for this use, since they are almost free from bubbles and are sufficiently homogeneous.

### Proof Plane

The proof plane is the most used of test plates. It serves to verify not only plane surfaces, but also very slightly curved surfaces, by measuring the rings which form around the point of contact of the surface upon it.

Let us consider a sphere of radius  $R$  and centre  $O$  (Fig. 65) in contact at  $A$  with a proof plane. Let us calculate the distance,  $CD = y$ , which separates from the plane a point  $C$  on the sphere, distant from the normal  $OA$  by a length  $CH = x$ . In the triangle  $ACB$  one has

$$x^2 = y(2R - y),$$

$y$  being very small with respect to  $R$ ,  $y^2$  is negligible and we can write

$$y = \frac{x^2}{2R}.$$

For a fringe appearing between *C* and *D*, it is necessary that

$$CD = y = p\frac{\lambda}{2},$$

*p* being a whole number and  $\lambda$  being the dominant wavelength of the light used.

Then, the diameter  $2x$  of the *p*th ring is

$$2x = 2\sqrt{p\lambda R},$$

that is to say, the diameters of successive rings are proportional to the square roots of the prime numbers.

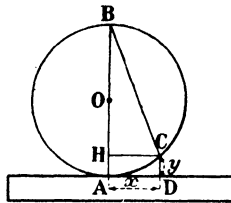

FIG. 65.

Working with yellow white light,  $\lambda = 0.00058$  mm. If it is desired to obtain a surface of 100 metres radius the above formula gives, for the diameter of the tenth ring,

$$2x = 48 \text{ mm.}$$

In order to measure this ring exactly it is indispensable to view the proof plane perpendicularly, and in consequence to displace the eye by 48 mm. between the two observations.

Let us suppose again, that, wishing to obtain a plane surface, one gets one giving on the proof plane two rings of which the larger has a diameter of 200 mm. The preceding formula, written in the form

$$R = \frac{x^2}{p\lambda},$$

gives

$$R = 9400 \text{ metres (convex curvature).}$$

If the contact is not perfect at *A*, the fringes are a little larger.

Let us suppose that, with the aid of a micrometer screw, one could very slowly raise the glass above the proof plane. Each time the interposed plate of air increased by  $\lambda/2$ , a fringe would make its appearance at the edge and substitute itself for the fringe of the preceding order. At the same time the central fringe would vanish and the following

fringe, by contracting, take its place. The reverse phenomenon occurs when the interposed layer of air is diminished. Thus without changing the appearance of the fringes or their size a fairly large thickness of air can be added to or removed from between the test plate and the surface to be verified, so long as it is exactly equal to any whole number of  $\lambda/2$ . The formula  $p = \frac{x^2}{R\lambda}$  applies, then, to at least 1 unit whatever the interposed thickness of air, *i.e.* even if little blocks are interposed between the surface to be verified and its test plate.

From this one is led to the case in which the thickness of air interposed is negative. This algebraic case does correspond to a reality; it is the case where the surface to be verified is concave, it then touches the test plate at the edges. The formulæ already found still apply, but the value of  $x$  is no longer arbitrary. It is the radius of the proof plane, if it is smaller than the surface to be verified, or the radius of the piece to be verified if it is that which is the smaller. In place of a central point of contact, there is an unalterable circle of contact in relation to which the rings can change. When the piece to be verified is pressed on to the plane the number of rings tends to diminish and the smallest to vanish towards the centre.

### Test Plates of Shallow Curvature

Let us again take the preceding figure, and add to it a sphere of centre  $O'$  (Fig. 66) and radius  $R' = R + \epsilon$ . This latter sphere is to

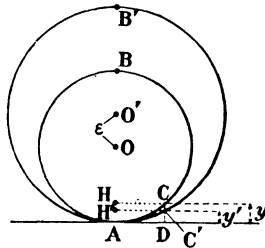

FIG. 66.

serve as a test plate for verifying the sphere of centre  $O$  and the line  $AD$ , which represented the proof plane, only represents a plane of reference.

The sphere of centre  $O$  gives, as has been seen,

$$y = \frac{x^2}{2R}.$$

Similarly the sphere of centre  $O'$  gives

$$y' = \frac{x}{2(R + \epsilon)},$$

$$CC' = y - y' = \frac{x^2}{2} \left( \frac{1}{R} - \frac{1}{R + \epsilon} \right) = \frac{x^2}{2} \frac{\epsilon}{R^2 + \epsilon R}.$$

For shallow test plates  $\epsilon$  is small, and  $R$  is large, so that  $\epsilon R$  is very small in relation to  $R^2$ . Thus the term  $\epsilon R$  may be neglected. If one fringe appears between  $C$  and  $C'$ , that is, if  $y - y' = p \frac{\lambda}{2}$ , then

$$\frac{x^2}{2} \frac{\epsilon}{R^2} = p \frac{\lambda}{2},$$

from which

$$p = \frac{\epsilon}{\lambda} \cdot \frac{x^2}{R^2}.$$

This expression shows:

1st. That the same number of fringes is always found for the same value of  $\epsilon$ , on condition that they are counted in a circle of radius  $x$  proportional to  $R$  in a constant ratio.

2nd. That the number of fringes is proportional to  $\epsilon$  for constant values of  $x/R$ .

For the legitimate application of this expression, the fringes must be observed parallel to the axis  $OA$ . In the case of large lenses of shallow curvature, then, one must displace one's head to see one edge of a ring after having looked at the opposite edge. Let us take, for example, the case in which one wishes to verify, with a test plate of 100 metres radius of curvature, a surface which should have a radius of 98 metres. The preceding formula allows of calculation of the radii  $x$  of successive rings.

$$x = R \sqrt{\frac{p\lambda}{\epsilon}}.$$

In white light,  $\lambda = 0.00058$ , and we have just supposed that  $R = 100,000$  mm. and  $\epsilon = 2000$  mm.

For the second ring  $p = 2$ , and we find

$$x = 76 \text{ mm.}$$

The second ring, having a diameter of 152 mm., the eye must be displaced by 152 mm. in order to measure it with the aid of a fixed scale.

If the glass under test is raised above its test plate by a whole number of  $\lambda/2$ , neither the appearance nor the number of fringes is changed,

exactly as in the case of the proof plane (see p. 186) and for the same reasons. Thus the formula  $p = \frac{\epsilon}{\lambda} \cdot \frac{x^2}{R^2}$  gives the number of fringes to at least 1 unit, whether the lens is presented to its test plate with or without the interposition of blocks.

**Test Plates of Deep Curvature**

When the curvature is strong enough and the angular aperture of the lens large enough, the expressions already given cease to be sufficiently closely approximate and, on the other hand, the fringes further from the centre of contact are no longer seen sufficiently normally to serve as a measure of the thickness of the plate of air. In this case the fringes should be observed by placing the eye in the neighbourhood of the centre of curvature and not displacing it to make measurements.

In these conditions,  $S$  being the surface to be verified and  $S'$  the test plate (Fig. 67), a fringe will appear between  $C$  and  $C'$  at an angular distance  $\alpha$  from the axis  $OO'$ , when the distance between the points  $C$  and  $C'$  measured on the radius  $OC$  (or on the radius  $OC'$  which almost merges with it) is equal to  $p\lambda/2$ .

The radius  $OC = R$ .

The radius  $O'C' = R' = R + \epsilon$ .

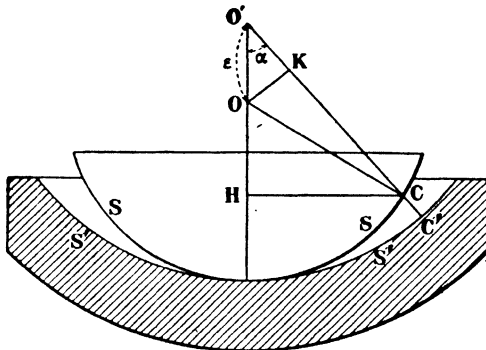

FIG. 67.

If  $K$  is the projection of  $O$  on  $O'C'$ ,  $\angle OCO'$  being very small, one has very nearly  $CK = OC$  and  $\angle HOC = \angle HO'C'$ ; one can write

$$CC' = O'C' - O'K - CK = \epsilon (1 - \cos \alpha) = p \frac{\lambda}{2},$$

from which 
$$p = \frac{2\epsilon}{\lambda} (1 - \cos \alpha).$$

Instead of taking  $\alpha$  as a parameter, one may prefer to adopt the parameter  $x/R$  as in the formula used for shallow curvatures, that is to say, the quotient of the semi-diameter of the disc  $x$  ( $=HC$ ) and the radius of curvature  $R$ . Then

$$\cos \alpha = \sqrt{1 - \frac{x^2}{R^2}},$$

and the preceding formula becomes

$$p = \epsilon \frac{2}{\lambda} \left( 1 - \sqrt{1 - \frac{x^2}{R^2}} \right).$$

There, again, the number of rings contained in a given circle is proportional to  $\epsilon$ , and that number remains constant when  $x$  and  $R$  change while keeping the same ratio between them.

The following table gives, for both formulæ (that for shallow curvatures and that for deep curvatures), the values of  $p$  for different values of  $x/R$  and for yellow or white light as well as for mercury light screened by a mercury green line filter.

TABLE OF NUMBER OF FRINGES FOR A DIFFERENCE OF  
RADIUS  $\epsilon = 0.1$  mm.

$\frac{x}{R}$	Shallow curves $p = \epsilon \cdot \frac{1}{\lambda} \cdot \frac{x^2}{R^2}$		Deep curves $p = \epsilon \cdot \frac{2}{\lambda} \left( 1 - \sqrt{1 - \frac{x^2}{R^2}} \right)$	
	Number of fringes in		Number of fringes in	
	White or yellow light	Filtered mercury green light	White or yellow light	Filtered mercury green light
0.1	1.7	1.8	1.7	1.8
0.2	6	7.6	7.6	8.1
0.4	27.5	29.3	28.6	30.3
0.8	110	117	207	220

The use of special green screens placed in front of the lamp and absorbing all radiations except the green ( $\lambda = 0.546 \mu$ ) gives a monochromatic light which allows slips of thicker paper to be placed between the test plates and lenses while still producing numerous sharp fringes.

This table, in which the numbers which must not be used have been separated in a black frame, shows that for values of  $x/R$  less than or equal to  $\frac{1}{10}$  the simpler formula is equivalent to the other. For the larger values of  $x/R$ , however, the more complicated formula must be employed if one wishes to measure the departure of the curvature of a lens from that of its test plate by the number of fringes. The case occurs of small lenses of high power. For these lenses the value  $\epsilon = 0.1$  mm. is exaggerated; the differences of radius of curvature are of the order of a micron, consequently the figures in the table relating to  $\epsilon = 0.1$  mm. are 100 times too great, and the number of fringes observed over the whole surface of the lens for an error of 1 micron in the radius would be about 2, which shows the necessity of utilising the largest possible surface of small lenses for the observation of the fringes.

It should be remarked that the use of the second formula is only legitimate so long as the two surfaces are rigorously in contact. One cannot, as when the first formula is used, place slips of paper between the surfaces unless the thickness of the slips is known and account of it is taken. Let us see how we can take account of it.

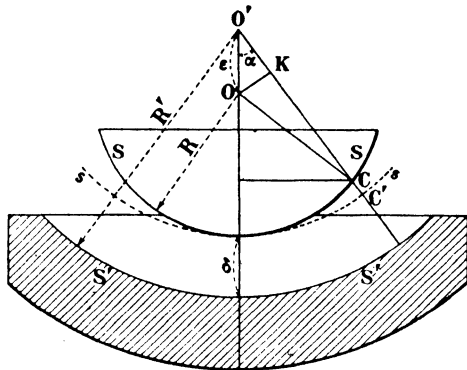

FIG. 68.

Let us suppose the two surfaces  $S$  and  $S'$  (Fig. 68) of radii  $R$  and  $R'$  separated by a distance  $\delta$ ; let us imagine a sphere  $s$  of radius  $r$  concentric with  $S'$  and tangential to  $S$  at its centre. The surfaces  $s$  and  $S$

of Fig. 68 exactly reproduce the dispositions of the surfaces  $S'$  and  $S$  of Fig. 67 and, in consequence, the formula

$$p = \frac{2\epsilon}{\lambda} \left( 1 - \sqrt{1 - \frac{x^2}{R^2}} \right)$$

can be used on condition that  $\epsilon$  is replaced by  $\epsilon - \delta$  and  $R$  by  $r$  which is equal to  $(R' - \delta)$ . But in practice  $\delta$  is negligible compared to  $R'$  and one can adopt the formula

$$p = \frac{2(\epsilon - \delta)}{\lambda} \left( 1 - \sqrt{1 - \frac{x^2}{R'^2}} \right).$$

But  $\epsilon$  and especially  $\delta$  are not generally known with enough precision to give  $p$  with a worth-while approximation. Nevertheless, a practical observation can be extracted from the preceding formula. When  $\delta = R - r = \epsilon$ , the surfaces being concentric, no fringe can be seen by an eye placed at  $O$ , and  $p = 0$ .

Here an observation which will sometimes be useful can be made. If a test plate in contact with a surface shows fringes to an eye placed at the centre of curvature, and if it ceases to show them (in monochromatic light) when slips of paper have been interposed between the surfaces then the difference of the radii of curvature is equal to the thickness of the slips. Cigarette paper having a thickness of about 30 microns, one could endeavour to make the fringes disappear by interposing several thicknesses of paper, when the difference of the radii is of the order of a tenth of a millimetre.

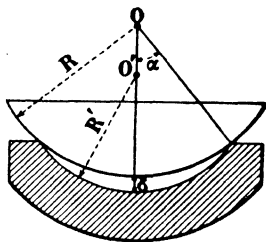

FIG. 69.

When contact takes place at the edge of the test plate (Fig. 69), that is to say, when the surface to be verified is shallower than the test plate, it can be verified that the formula of p. 189,

$$p = \frac{2\epsilon}{\lambda} (1 - \cos \alpha),$$

is applicable without modification.

The back surface of test plates to which the formula relating to shallow curves is applied, should be plane and polished, and one should take care to observe quite normally to this plane face when the fringes are seen through the test plate.

The back surface of concave test plates with which the formula for deep curves is employed should be curved and parallel to the true surface (Figs. 64, 68, 69). It is advantageous to make the second face of convex test plates more curved than the true face (Fig. 70). It has been seen, indeed, that it is necessary to observe the fringes by placing the eye at the centre of curvature. If the untrue (back) face were plane, refraction would bring back the reflected rays not to the centre of curvature  $O$  but to a point closer to the centre (of the test plate). But for observing small lenses it is better to bring back the reflected rays to a point  $O'$  further away from the test plate.

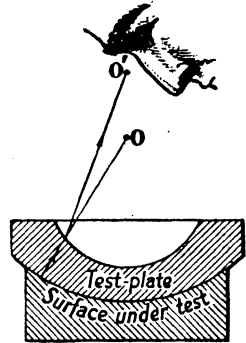

FIG. 70.

The form of test plate shown in Fig. 70 may be recommended. The condition of placing the eye close to the centre of curvature necessitates the use of a magnifier for observing small, deeply curved lenses. The use of a magnifier is, moreover, natural from every point of view in this case, since the fringes are localised in the film of air.

It is sometimes suitable to shape the test plate in the form of a Stanhope magnifier. The Stanhope magnifier consists of a cylinder of glass about 3 or 4 cm. in length of which one extremity is convex and the other extremity, of any form, contains the focus of the lens thus formed. It is this extremity of indifferent shape that one can employ for surfacing as a test plate.

Fig. 71 represents a Stanhope test plate for verifying small concave surfaces. A "waist" near the centre of curvature of the test surface only allows the rays reflected almost normally to pass; the little shoulder which surrounds the "waist" allows the surface under examination to be illuminated.

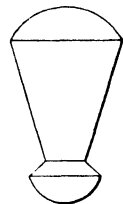

FIG. 71. Stanhope test plate.

This form is less suitable for verifying small convex surfaces, for it will only allow a very small part of the surface to be seen at once.

Fig. 72 shows a small lens blocked on a mallet stick and covered with a test plate through which an eye observes the fringes with the help of a magnifier.

The method just described for obtaining test plates which have a given radius of curvature to  $\frac{1}{100}$  or  $\frac{1}{1000}$  of a millimetre is evidently

applicable to the construction of a surface of slightly different curvature. If the curvature to be realised differs very little from that of a test plate already in existence in the workshop that test plate can serve for verifying the new curvature. It will suffice for this to calculate the number of rings corresponding to the difference between the curvatures of the test plate and of the new surface. The number of rings is the same whether that difference is positive or negative, but if the surface to be verified is less curved than the test plate the largest ring will not change under pressure; it will increase, on the contrary, if the surface to be verified is more curved.

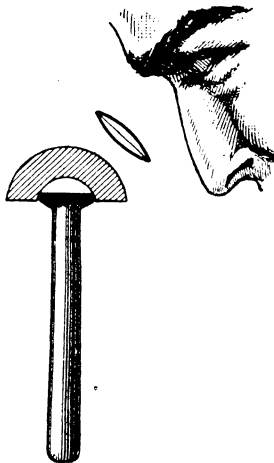

FIG. 72. Test plate examination of a small lens

In the preceding chapters the processes of surfacing which are susceptible of increasing or diminishing the curvature of a lens have been described. It is useful to repeat them here.

To increase the convexity or diminish the concavity of a test plate one can choose between several means or employ them together; "scouring", braking the rotation of the glass on an automatic machine or hand working on a pedal or hand lathe, relieving the central region of the polisher.

To diminish the convexity or increase the concavity one can work with overlap, cut away the polisher towards the edges, but, above all, one can work on a fixed tool post while methodically varying the overlap.

The method of surfacing to the number of fringes allows of realising aspherical surfaces differing slightly from a sphere. The application of

this to the surfacing of parabolic mirrors for telescopes of modest dimensions will be seen later.

### **Cylindrical Test Plates**

A pair of spherical test plates of the required curvature is first made but only the convex part is used.

Prepare a cylindrical convex test plate of approximately the curvature required; verify the straightness of its generatrices by putting it on a proof plane, lit by a mercury lamp. The generatrix in contact produces a narrow band in which, by means of a magnifier, one sees the commencement of interference rings if the generatrix is not straight. Retouch the cylinder until the generatrices are straight. A provisional convex cylindrical test plate is thus obtained.

Prepare a cylindrical concave test plate of approximately the curvature required; make use of the provisional cylindrical convex test plate only to verify the generatrices of the concave test plate. Use the convex spherical test plate to verify the directrices.\* Retouch the concave cylindrical test plate until the commencements of rings have all disappeared to the same extent on the lines of contact with the provisional cylinder as they have on those with the convex sphere. The concave test plate thus being realised, retouch the provisional convex test plate to match it.

Mark on each piece the exact direction of the axis.

One then has a pair of cylindrical test plates with which a batch of cylindrical lenses could be worked to the test plate exactly as a batch of spherical lenses is verified by the test plate.

### **Toric Test Plates**

The necessity of giving a transverse motion to the tool, that is to say, one normal to the equator of the toric, in order to avoid striæ, prevents the realisation of a geometrical toric. One can only obtain a surface approximating to it so long as the amplitude of the transverse movement is small. Toric test plates must, then, be more templates for the surface to be realised than typical torics in the geometrical sense of the word. Their use can allow of verification of careful production and for fixing, in fringes, the tolerances of curvatures along the axis—that is to say, along the equator—and in the medial section normal to the axis.

First, two sets of spherical test plates are constructed, each defining one of the two curvatures of the toric surface to be realised. The concave part of the spherical test plate of large curvature is used for veri-

Directrices are lines perpendicular to the axis of a conic section, by which its nature may be defined. In a cylinder they will be arcs on the circumference whose radii are normal to the axis. (Trans.)

fyng the curvature along the axis of a provisional convex test plate and one rectifies, if need be, that curvature. The convex part of the spherical test plate of the transverse curvature is used to verify the curvature of the section normal to the axis of a provisional concave test plate and, if need be, that curvature is corrected.

The two curvatures of the provisional test plates thus rectified serve to verify the corresponding curvatures of their counterparts. They are rectified, if necessary, and one then possesses a pair of toric test plates to which one can work.

### ASPHERICAL SURFACES

Laboratory methods of examining precise aspherical surfaces are necessary, but in this book only practical workshop methods for guiding the optician in his work before the finished piece can be submitted to the laboratory are dealt with. In the workshop, for verifying surfacing in course of execution, only gauges are available, pro-

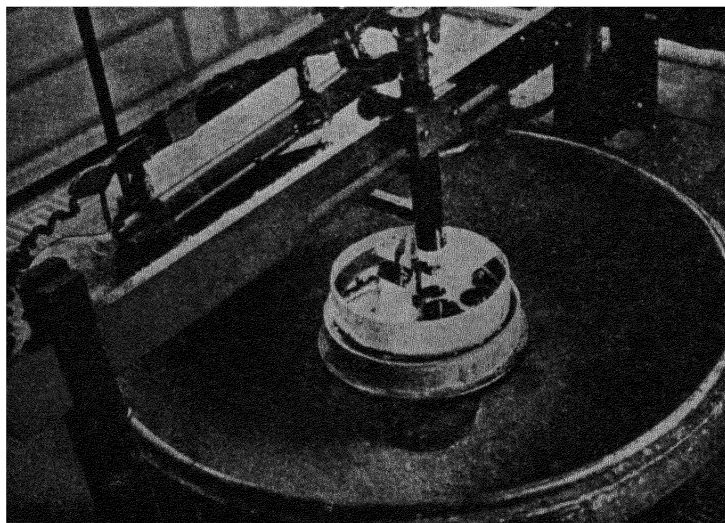

FIG. 15. Fringe viewer mounted on the bridge bar of a lathe with adjustable relative rotations.

filed sheet templates for roughing, glass test plates for interference tests. If one has an aspherical test plate available which is the counterpart of the surfaces under construction, its use presents no special difficulty, unless it is the need for centring it very exactly on the lens to be tested. But for verifying the aspherical test plate itself during

Its construction, as for verifying all aspherical curvatures in the general case, there must be a collection of spherical test plates of dimensions varying progressively step by step, which should touch the surface to be tested upon a certain number of concentric circles.

The constructor will have the diameter of the circumference of contact for each test plate calculated, as well as the number and the separation of the rings on either side of that circumference. In practice one can hardly count more than 30 to 40 fringes on each side and this condition determines the number of test plates necessary for testing a given aspherical surface. Such a large number of fringes can only be observed in monochromatic light. The optician must have at his disposal a mercury lamp and a special viewer which is pointed normally at the surface and whose displacements can be measured exactly, when he counts the fringes or verifies the diameter of the circumference of contact. The viewer contains a plate of glass inclined at  $45^\circ$  to direct the light from the lamp normally to the surface. Such a viewer is seen in its working position in Fig. 73.

### PARABOLISATION

Parabolic mirrors for lighthouses and searchlights are made by industrial means which do not possess a precision comparable with that of astronomical mirrors, moreover, large aperture mirrors having a very accentuated parabolic curvature must be worked on special machines. There are also in this category parabolic condensers for lateral illumination of microscopes; they do not need to be surfaced with great precision since they are not destined to form images.

#### Telescope Mirrors

These mirrors differ so little from a sphere inscribed tangentially along their sides that the substance to be removed in passing from the sphere to the paraboloid of revolution is easily removed in polishing. To fix our ideas, in the case of a parabolic mirror of 25 cm. diameter and 1.35 metres focal length, the distance between its sides and a sphere of 2.70 metres radius, tangent at the centre of the mirror, hardly exceeds 1 micron.

The smoothing operations, then, only concern the construction of the spherical mirror, which is afterwards transformed into a parabolic mirror by polishing.

To obtain a parabolic mirror, Professor G. W. Ritchey counsels the construction first of a perfect spherical mirror and then wearing away the middle while conserving the edges in such a way that the parabolic mirror remains circumscribed at its edges by the initial sphere. Moreover, in working thus, the weight of material that must be removed

is much smaller than that to be removed in parabolising by wearing away the edges while conserving the centre of the mirror.

Let us consider a concave spherical surface giving an even colour on a test plate and see how the concave glass must be worn away to transform it into a parabola which is only tangential to the test plate at its circumference.

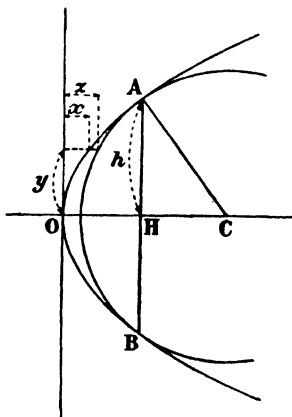

FIG. 74.

Let  $f$  be the focal length of the mirror,  $f/q$  its angular aperture,  $C$  the centre of the sphere tangent to the edges of the paraboloid at  $A$  and at  $B$ .

Let us consider a section on the axis of the paraboloid and refer the sphere and the paraboloid to their common axis and to the tangent at the vertex of the paraboloid. Designating the abscissæ of the paraboloid by  $x$  and those of the sphere by  $z$ , for common values of their ordinates  $y$  in the axial plane, the equation of the parabola is

$$y^2 = 4fx.$$

It is known that the cathetus  $CH = 2f$ .

Let us make  $AB = 2h$ .

From this we deduce

$$h = \frac{f}{2q}, \quad OH = \frac{f}{16q^2}, \quad \text{and} \quad OC = \frac{1 + 32q^2}{16q^2}f.$$

The equation to a great circle of the sphere is then

$$y^2 + \left[ \frac{1 + 32q^2}{16q^2}f - z \right]^2 = \frac{1 + 16q^2}{4q^2}f^2.$$

By writing  $z - x$  as a whole number of half-wavelengths, that is to say,  $z - x = p\frac{\lambda}{2}$ , an equation is obtained giving the value of the radius of the  $p$ th ring for a given value of  $q$ .

To establish the required equation, one must observe that  $\lambda$  being very small in relation to  $f$ , the terms with  $\lambda^2$  may be neglected.

Thus is found the equation

$$y = \sqrt{\frac{f^2}{4q^2} - 2f(p\lambda \pm 2\sqrt{2p\lambda f})}$$

But the term  $p\lambda$  also is negligible in comparison with  $\sqrt{2p\lambda f}$  (supposing there are 10 fringes and a focal length of only 1 metre the root is 1000 times greater than  $p\lambda$ , and this term  $p\lambda$  will be still more negligible for the usual focal lengths of telescopes).

The useful equation can, then, be written,

$$y = \sqrt{\frac{f^2}{4q^2} \pm 4f\sqrt{2p\lambda f}} \dots \dots \dots (1)$$

The + sign before the small root corresponds to fringes in the annular region, *i.e.* above the tangent circle of the sphere on the parabola, the radius of this circle being equal to  $\frac{f}{2q}$ ; the - sign corresponds to the central part of the parabola.

This equation shows that the surfaces of the rings bounded on one side by an interference fringe and on the other by the circumference of tangency are to one another as the square roots of the first  $p$  numbers. That is a law which characterises the parabolic mirror compared with an inscribed sphere.

If it is desired that the central part of the hollowed sphere shall be conserved and that it shall be parabolised by wearing away the annular regions, it is necessary to write that the sphere instead of touching the parabola around a circle of aperture  $\frac{f}{q}$ , touches it around an infinitely small circle. For this it suffices to suppress the term  $\frac{f^2}{4q^2}$  in equation (1) which becomes

$$y = 2\sqrt{f\sqrt{2\lambda f}} \sqrt[4]{p} \dots \dots \dots (2)$$

showing that the radii of the circles of fringes are to one another as the fourth roots of the first  $p$  numbers.

By making  $p = 1$  in equation (2) the radius of the first fringe is found and it is noticeable that the central part of the parabola practically merges with the sphere over a considerable distance. Thus, for a mirror of 1.35 metres focal length, lit by a mercury lamp ( $\lambda = 0.546 \mu$ )

the first fringe must have a diameter of 161.7 mm. when the contact between the parabola and the spherical test plate is perfect at the summit. If the contact is imperfect the first fringe is smaller; but when the space between the parabola and the test plate attains a half-wavelength the small fringe vanishes, and a new fringe with a diameter of 161.7 mm. appears. The other fringes have at that moment the following diameters, 188 mm., 212 mm., 228 mm., 242 mm., 252 mm. From these figures it may be deduced that at the edge of the mirror considered, of 250 mm. diameter, the difference between the mirror and the test plate should not attain  $1.2 \mu$ .

One could then, starting from the perfect hollowed sphere, preserve its centre and make successive fringes appear following the law of fourth roots, by wearing the surface more and more towards the edges.

Experiment seems to have established that it is preferable, on the contrary, to preserve the edges and to wear away the central part. When the work is finished the fringes must succeed one another according to the law expressed by equation (1).

The radius of curvature at the summit of a parabola is equal to the projection on the axis of the parabola of a normal  $PN$  at any point  $P$  on the parabola (Fig. 75). (This projection being constant and equal to  $2f$ , whatever the position of  $P$ , as has been seen in studying Fig. 74 in which  $CH = 2f$ .)

When the parabolisation of a hollowed sphere fitted on a spherical test plate of radius  $PN = R$  and upon which it should rest tangentially on a circle  $PP'$  is concerned, it is necessary to hollow out the centre of the concave sphere progressively until, at the summit, it is given a curvature whose radius is equal to  $MN$ , *i.e.* to  $R \cos \alpha$ .

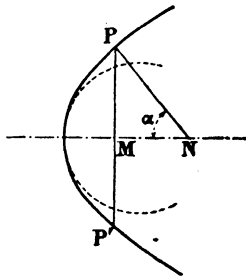

FIG. 75.

One first conserves a large spherical zone  $PP'QQ'$  (Fig. 76) and parabolises the little cap  $QQ'$  of aperture  $2\beta$ , by giving it, at the summit, a curvature whose radius equals  $R \cos \beta$ . Then the parabolisation is extended to a slightly larger cap of aperture  $\beta'$ , and a radius of  $R \cos \beta'$

is obtained at the summit. One continues thus, until the whole of the spherical zone  $PP'Q'Q$  has been caused to disappear.

At each partial parabolisation the work is verified by examining the fringes.

*Parabolisation of a mirror of 250 mm. diameter and 1.35 metres focal length*

To fix our ideas, let us again take the example of the parabolisation of a mirror of 1.35 m. focal length and 250 mm. diameter. A spherical convex test plate of 2.697 m. radius of curvature is made, for, the value of  $\alpha$  being about  $2^\circ 40'$ ,

$$2.703 \text{ m.} \times \cos \alpha = 2f = 2.7 \text{ m.}$$

This test plate is fitted to a special counterpart, or even simply to the mirror destined for parabolisation. It is with this convex test plate that the parabolisation is followed by placing it on the polished mirror which is separated from it by three scraps of blotting paper in order not to scratch it and illuminating it by mercury green light ( $\lambda = 0.546 \mu$ ).

The mirror being found to be perfectly spherical, parabolisation will be commenced on a cap of aperture  $f/8$ , that is to say, that  $q$  is given the value of 8. This cap is bounded by a circle of 168 mm. diameter. It is worn away until a single fringe 58 mm. in diameter is obtained. About  $0.3 \mu$  of material must be removed for this.

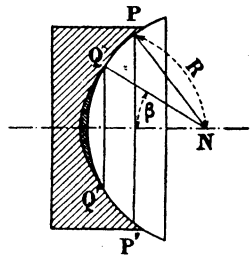

FIG. 76.

Then  $q$  is taken as equal to 7, which gives

Diameter of circle of contact .. .. .	..	193 mm.
Diameter of first ring .. .. .	..	110 mm.
Diameter of second ring .. .. .	..	41 mm.

Then  $q$  is taken equal to 6, which gives

Diameter of circle of contact .. .. .	..	225 mm.
Diameter of first ring .. .. .	..	160 mm.
Diameter of second ring .. .. .	..	123 mm.
Diameter of third ring .. .. .	..	85 mm.
Diameter of fourth ring .. .. .	..	20 mm.

The annular part which remains spherical is narrow and, if one wished to obtain a parabolic mirror of greater aperture, one could pursue the same method, giving to  $q$  smaller and smaller values, even fractional ones, for example,  $q = 5.5$  and  $q = 5$ . Then the edges of the mirror would be worn away a little without attacking the cir-

circumference of contact, in order to cause the first rings of the zone exterior to the circle of contact to appear. These rings should have diameters of 275 mm., 294 mm., 317 mm., if the mirror is to have an aperture larger than we have supposed (250 mm.).

If the workman is sufficiently skilled he can verify his parabolic mirror with a much smaller spherical test plate. Thus, in the chosen example, a test plate of 85 mm. diameter would suffice for verifying, by fringes, a mirror of more than 300 mm. diameter. It is not necessary, indeed, that the test plate shall be centred on the mirror, it will suffice if it covers several centimetres of the circumference of contact and the centre of the mirror and if it can be arranged in such a way that all the fringes are concentric with the mirror.

The diagram (Fig. 77) shows that at each partial parabolisation one should not approach within 10 or 15 mm. of the circle of contact. The smallest circle of contact having a diameter of 168 mm., the projecting part of the polisher to be employed in the parabolisation must not have a diameter greater than 10 cm.

If one shrinks from the difficulty of contriving a circle of contact which is not close to the edge of the mirror one could, even in this case, be satisfied with a test plate whose diameter is a little larger than the radius of the mirror.

In any case, the method will always consist in transforming a larger and larger cap of the mirror. One will form successive paraboloids a little different from one another but larger and larger and always circumscribed by the same sphere. During parabolisation the mirror will be composed of a central parabolic zone prolonged by an annular spherical zone.

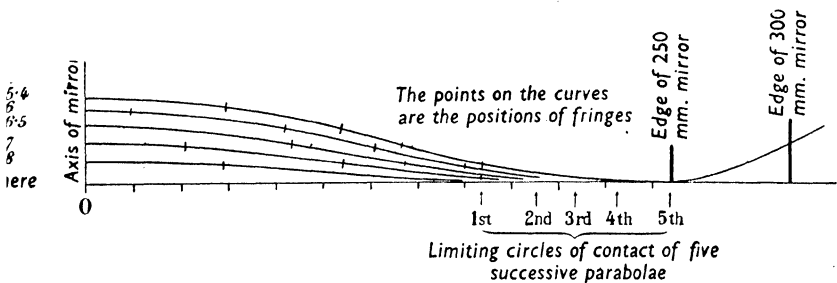

FIG. 77. Diagram of thicknesses of material to be removed in five successive partial parabolisations. Maximum thickness to be removed, 1.18  $\mu$ .

Verification by the fringes can only give a sufficient precision when they are viewed quite normally to the surface. If one has not at one's disposal a special interferometer which can be placed on the lathe above the work, a sheet of white cardboard or paper pierced with a

central hole should be placed plumb above the zone to be observed and observation should be made through the hole.

The verification of a parabolic mirror by fringes can, thanks to the arrangements indicated above, be applied to mirrors up to 50 or 60 cm. diameter. For larger mirrors expensive spherical test plates of unmanageable size would be necessary. The construction of large mirrors demands delicate laboratory verifications in the course of surfacing; the workshop cannot be self-sufficient, but must be guided by the laboratory in the execution of local retouching. Laboratory verification is even necessary for mirrors whose parabolisation has been followed by frequent examination of the fringes produced by a test plate, but the examination of the fringes dispenses with frequent recourse to the laboratory during polishing. The study of the methods used in laboratories for verifying optical surfaces is outside the scope of this book, but the best known of these methods must be cited. It is Foucault's method.\*

The advantage of the mercury lamp, for the examination of fringes has already been pointed out, but, when working with larger test plates and frequently repeating the verification, as is necessary in surfacing an astronomical mirror "by the number of bands", it is practically indispensable to work only under mercury light. If, indeed, one used white light, one could not avoid scratching the surface, on account of the necessity of pressing on the test plate and sliding it about until the fringes appear. Working, on the other hand, under a mercury lamp a thick plate of air can be left between the two surfaces and three scraps of blotting paper can be placed between the mirror and the test plate, as mentioned above. The fringes are seen without pressing on, or sliding, the test plate, and can be centred as desired by a slight lateral pressure either by hand, by jointed levers, or by micrometer screws situated directly above the slips of paper. The precision of measurement is easily augmented by pressing on the test plate just enough to reduce the central ring to a point. It is at this moment that the fringes should be counted and we know already that by compressing the slips of paper in such a way as to cause the thickness of the air layer to vary, a ring is seen to appear or disappear every time that that thickness varies by  $\lambda/2$ .

### Searchlight Mirrors

These mirrors do not demand the precision of astronomical parts, nevertheless, the surface of a searchlight mirror must be good enough to give a beam of light that is still condensed at a distance of several kilometres.

This is the process of verification used by the (French) Navy for the

\* Other methods are described or referred to by Twyman, *loc. cit.* (Trans.)

examination of their searchlights. It can be applied near the optical workshop.

An approximately point source (arc lamp) is placed at the focus of the mirror. In front of, and close to, the mirror is placed a frame on which wires forming a regular network of squares, are stretched. At least 1 metre farther away there should be a screen or a white wall upon which the image of the frame is projected. A small screen placed against the light source prevents it from illuminating the large screen directly.

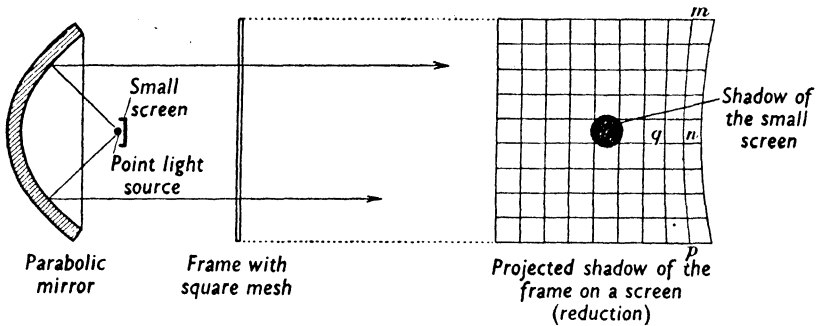

FIG. 78. Testing device for a searchlight mirror.

In these conditions the frame should only receive parallel light and its projected shadow should be an orthogonal projection; the shadows of the wires should be rectilinear and equidistant. If this is not so the mirror has not a parabolic form all over. If, for example, the shadow  $mnp$  of a wire is convex towards the centre, the distance  $nq$  between two neighbouring shadows being too small, it means that the part of the mirror which sends light to the region  $n$  is not worn away enough, since the light which it reflects converges towards the optical axis.

### VERIFICATION OF PARALLEL PLATES

The use of a mercury vapour lamp is essential when it is desired to produce interference fringes between two surfaces of a plate some millimetres in thickness, in order to test the variations of that thickness in half-wavelengths.

Two processes are in use for measuring errors of parallelism: 1st, the process called "fringes at a finite distance", or of equal thicknesses, produced in the plate by the variations in thickness which the rays of a parallel beam encounter: 2nd, the process called "fringes at infinity", or of equal inclinations.

### Method of Fringes at a Finite Distance

If the plates to be examined are very thin an ordinary interference apparatus (Fig. 79) can be made use of. It comprises a lens *A* at whose focus a diaphragm is placed, in front of a mercury lamp *L*. A beam of approximately parallel light passes out of this lens and falls on a glass *B* at  $45^\circ$  which directs it normally upon the plate *C* to be examined. The fringes produced in the plate are observed by the aid of a magnifier *D*. The beam must be normal to the plate in order that a small variation in direction will not sensibly change the thickness of glass which is traversed and will not alter the path length.

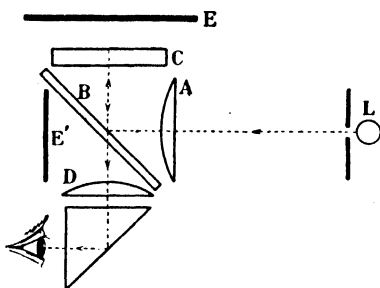

FIG. 79. Diagram of interference apparatus for testing parallel plates by observing fringes at a finite distance.

For convenience of operation a prism which permits horizontal observation is placed under the magnifier and at *E* and *E'* are placed movable screens to form a black background against which the fringes stand out clearly.

The eye must be placed at the exit pupil of the whole system, that is to say, where the image of the diaphragm in front of the lamp is formed; it is indeed the only place at which one can see the fringes over the whole extent of the plate.

When the plate to be tested is thick (viz. 10 mm.) the fringes only appear if the illuminating beam is exactly parallel and not merely nearly parallel. A defect in parallelism of the beam produces a mistiness of the fringes, which is very quickly accentuated with the thickness of the plate. If a ray, in departing from the parallel beam, has its path difference altered by 1 wavelength in a plate 1 mm. thick the alteration will be 10 wavelengths in a plate of 10 mm. thickness. If, on account of the spherical aberration of the lens *A*, or for any other reason, the beam falling on the plate were a little convergent, an

\* An analogous instrument is made in Great Britain by Adam Hilger Ltd., and called an Interferoscope. Its simplified design employs a concave mirror of long focal length in place of the two lenses shown above. (Trans.)

exactly parallel but slightly curved plate centred on the point of convergence of the beam would show an even colour, which one would not see, but which one ought to see, in a plate with perfectly plane parallel faces. One must then take steps to see that the illuminating pencil is practically parallel.

To realise this condition sufficiently, a diaphragm which reduces the light source to a small round spot must be placed against the lamp (Fig. 79) and, if possible, the lens  $A$  must be replaced by an objective of fairly long focal length. Spherical aberration of a single lens sends oblique rays towards the edges of the plate, the parallel rays only falling on the middle of the plate. A long focal length has the advantage of diminishing the parallax of the diaphragm and the light source.

The process of fringes at a finite distance has the great advantage of making the whole of the plate visible at a glance and locating its imperfections. It is a suitable instrument for seeing whether a plate is acceptable or whether it should be sent back to the workman. But it does not permit an interpretation of the fringes from which may be deduced the regions which are too thick and must still be worn away.\*

To find this out one is obliged to have recourse to the procedure of "fringes at infinity", which permits direct measurement of the differences of thickness between two very small zones of the plate.

### Procedure of Fringes at Infinity †

In this procedure, instead of examining the fringes corresponding to variations of thickness, one employs an apparatus which exhibits the fringes obtained by variations of inclination of the rays reflected towards the observer.

It has been seen (Fig. 61) that the path difference of two rays received in the direction of point  $A$  by an observer (whose eye is at  $X$  —not shown) varies with the inclination of that direction and with the thickness of the plate. If the thickness is appreciably constant over the field of view, the path difference is a function of the inclination only.

When two parallel rays, such as  $AX$  and  $CX$ , arriving at the edge with a certain obliquity, interfere with one another, all the parallel rays arrive at the eye with the same obliquity and, issuing from regions where the plate has the same thickness as at  $A$ , interfere also. In directions such as  $XA$  the eye will see dark spots forming a dark ring. A second fringe will appear at another obliquity if the difference of obliquity increases or diminishes the path difference of the two parallel

\* The Hilger Interferoscope, described by F. Twyman (*loc cit.*, pp. 108-9), includes means of carrying out such interpretations. (Trans.)

† Compare with Twyman's description of the Michelson and Twyman-Michelson tests (*loc. cit.*, pp. 109-12). (Trans.)

rays such as  $AX$  and  $CX$  by  $\lambda$ . By receiving these parallel rays on an objective, a spot, which can be observed with an eyepiece, is formed in the focal plane of the objective. This spot is dark or light accordingly as the component rays interfere or are in phase. Thus with this objective and this ocular, a telescope focused for infinity is constituted.

The apparatus for testing parallel plates by observing fringes at infinity consists (Fig. 80) of:

1st, a glass plate  $G$  inclined at  $45^\circ$  receiving, through the intermediary of a condenser  $C$  the monochromatic light from a source  $S$  and reflecting it on to the parallel plate to be examined at  $A$ .

2nd, a small telescope  $L$  adjusted to infinity.

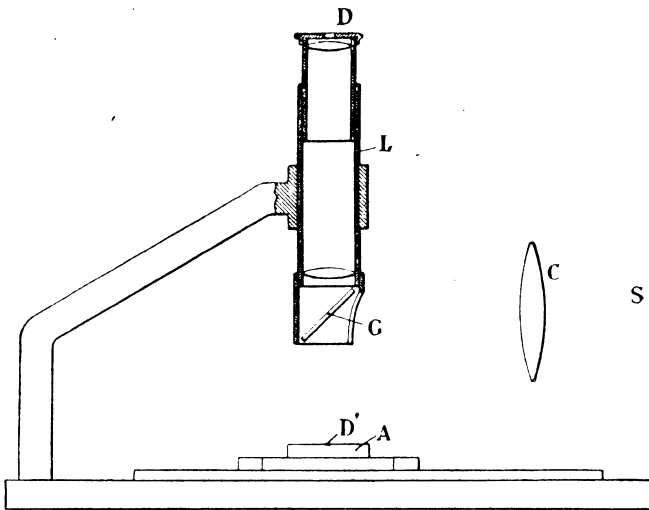

FIG. 80. Apparatus for testing parallel plates by observation of fringes at infinity

As the interference phenomenon described above requires that the thickness of the plate does not vary appreciably, it is necessary that the eye shall only receive the light reflected by a very small zone of the plate. The telescope is fixed in such a position that it gives, just on the parallel plate, a reduced image  $D'$  of the eyepiece pupil  $D$ , thus only a small circle of about 1 or 2 mm. isolated on the plate is used. One then sees little annular fringes closer and closer together. They do not change in appearance when one displaces the telescope transversely to explore the plate, so long as the plate is rigorously parallel. If it is not exactly so, one sees the rings diminish or increase in diameter; they seem to disappear in the centre, or, on the contrary, to leave the centre and grow larger. Each time a ring disappears and a new ring

appears the thickness of the plate has varied by  $\lambda/2$ . The rings get smaller as the thickness of the plate gets smaller. If, for example, 10 rings leave the centre when the telescope is displaced by 5 cm. in moving from left to right, it shows that the thickness to the right is too great by  $2.8 \mu$ .

### TESTS OF ANGLES

In laboratories there are goniometers of high precision which permit measurement of angles to about 2 sec., but these delicate, cumbersome and expensive instruments ought not to leave the laboratory. Nevertheless, the workman cannot form an angle with a greater precision than that of which the instruments and methods of test at his disposal are capable. In general, the workman will not make measurements but comparisons. With the help of fairly simple instruments he will be able to compare a standard angle with the angle he has just formed, with precision. But how are these prototype angles to be formed with a precision of a few seconds without recourse to laboratory goniometers? It is possible to do this for a right angle and its principle sub-multiples, by the methods indicated below.

#### Jarret's Procedure or Bevel-gauge Method for forming a Right Angle and an Angle of $45^\circ$ to about $20''$

This procedure does not require the use of an exact angle protractor; that is its main interest.

Two right angle prisms are trued. One endeavours to give each of them an acute angle, which, compared to a bevel-gauge of about  $45^\circ$ , gives exactly the same appearance as that of the corresponding angle of the second prism. Thus, these angles are as equal as this test permits, let us say, they are both exactly  $46^\circ$ .

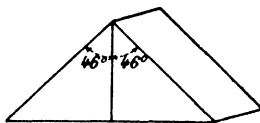

FIG. 81.

The two prisms are cemented together with the two  $46^\circ$  angles adjacent (Fig. 81); thus an angle of  $92^\circ$  is formed.

The opposite face is smoothed; the angles which terminate it are together equal to  $180^\circ - 92^\circ = 88^\circ$ . Let us say, that one is  $43^\circ$  and the other  $45^\circ$ .

In comparing these two angles by the bevel-gauge their difference is immediately obvious. The large face is retouched until that difference has disappeared. At that moment the two prisms, placed in the bevel gauge, show a little triangular space (Fig. 82) and the appearance of this triangular space is the same with the two prisms. Thus the two angles compared might each be  $44^\circ$ . On unsticking the two prisms one has two right angle prisms since their acute angles are  $46^\circ$  and  $44^\circ$ . If one wants to have isosceles right angle prisms, it suffices, in each prism, to bring back the acute angles to equality.

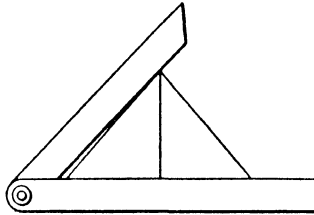

FIG. 82.

The precision of the method is high, especially with large prisms, for a difference of a few microns in the space which the bevel gauge leaves is visible; a space of 5 microns is easily appreciated. On a prism of 5 cm. a space of 5 microns close to one of the summits represents an angle of 20 sec. That is the precision which the procedure can give with a prism of 5 cm.; with a prism of 17 mm. one has only a precision of a minute.

If it is desired to make small right angle prisms with precision, they may be stuck together to large prisms whose right angle has been truncated, and worked together as in the case of one-piece prisms.

**Procedure for obtaining a Right Angle and an Angle of  $45^\circ$  to about 2 seconds on a Prism of some centimetres length of face, starting from a proof plane**

The high precision indicated in this heading is meaningless unless the faces of the prism are plane to at least about half a fringe. This condition must be realised before each test.

Make, simultaneously, three nearly equal right angle prisms, one face always being placed between protectors in order to avoid the edges being rounded off.

Take off the protectors for each test.

### Right Angle

Lay prism No. 1 on the proof plane so that one of the faces of the right angle (cathetus face) is in perfect contact (one fringe showing over the whole surface).\*

Place prism No. 2 in the angle formed by prism No. 1 (Fig. 83). Examine by the fringes, whether prism No. 2 is more or less obtuse than the angle formed between prism No. 1 and the proof plane. Arrange that the fringes are parallel to the edge formed by the angle. Count the fringes on both faces of the right angle of prism No. 2.

In the same way put prism No. 3 in place of No. 2.

Retouch prism No. 3 in such a way that it gives exactly the same fringes as No. 2. The angles of these prisms will then be equal but they may differ from a right angle to the same small extent.

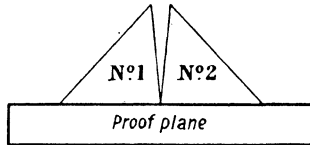

FIG. 83.

Replace prism No. 1 by prism No. 3. Count the total number of fringes formed by the prisms between themselves and with the plane. This number measures twice the error between the angle of the prisms and  $90^\circ$ .

When the three prisms are interchangeable they all have an angle of exactly  $90^\circ$ .

### Precision

If, two prisms being placed on the proof plane in such a way as to exhibit one fringe overall, the faces normal to the proof plane make an angle of  $\frac{1}{2}$  fringe, this angle has the value

$$\alpha = \frac{0.28 \mu}{l}$$

( $l$  being the length of a face).

For  $l = 50$  mm.,  $\alpha = 1$  second.

These two prisms, then, give the right angle to less than 1 sec., but, on account of the errors of observation of the fringes one can hardly count on an approximation of less than plus or minus 2 sec.

\* This perfect coincidence simplifies the explanation, but it is not indispensable. If the prism placed on the proof plane shows several quite straight bands parallel to the right angle edge, the fringes may be counted to measure the angle between the two faces in contact and account taken of this angle, as is explained later.

**Angles of 45°**

Having the three right angle prisms it is easy to correct the acute angles to the exact value of 45° in the following manner:

Place prism No. 1 on the proof plane (Fig. 84).

Put the two prisms, Nos. 2 and 3, together by their hypotenuses and place this double prism in the right angle formed by No. 1 prism with the proof plane.

Let us suppose that one of the acute angles  $A$  of prism No. 2 is equal to  $45^\circ - \alpha$ ; the other acute angle will be equal to  $45^\circ + \alpha$ . Let us suppose that the angle  $C$  of prism No. 3 is equal to  $90^\circ - \epsilon$  and its angle  $A$  equal to  $90^\circ - \beta$ ; its angle  $D$  will be equal to  $45^\circ + \beta - \epsilon$ .

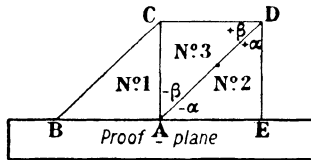

FIG. 84.

It is easy to measure  $\alpha + \beta$  by counting the number of fringes on the faces  $AB, AC, AD$  and  $AE$ , but care must be taken to note the direction of the slope on each face and take it into account. In other words, these numbers of fringes must be added or taken away, according to whether the prisms touch at  $A$  or by one of the edges  $B, C, D$  or  $E$ .

If the acute angles at  $A$  are smaller than 45°, the faces are closer together nearer the edge  $A$  than towards the edges  $B, C, D, E$ . The numbers of fringes are then counted as positive when the contact is with respect to  $A$ .

Let  $P$  be the algebraic sum of these numbers of fringes. The values of  $\alpha$  and  $\beta$  measured in fringes satisfy the equation

$$\alpha + \beta = P.$$

Let us turn prism No. 3 over and count the fringes. It is found that

$$\alpha - \beta + \epsilon = Q.$$

Adding these two equations, we get

$$\alpha = \frac{P + Q - \epsilon}{2}.$$

One then knows how the hypotenuse of prism No. 3 must be retouched to make the prism isosceles. The measurements and the

retouching are repeated until this result is attained, that is, until  $P + Q - \epsilon = 0$ .

*Example.* Let us suppose the angle  $C$  of prism No. 3 is equal to  $90^\circ + \epsilon$  and  $\epsilon$  equals one fringe. Let us suppose, moreover, that one notes

On face  $AB$ , 2 fringes, contact at  $A$ .

On face  $AC$ , 15 fringes contact at  $C$ .

3 fringes, contact at  $A$  after turning over prism No. 3.

On face  $AD$ , 8 fringes, contact at  $D$ .

1 fringe, contact at  $D$  after turning over prism No. 3.

On face  $AE$ , 10 fringes, contact at  $A$ .

12 fringes, contact at  $A$  after turning over prism No. 2.

$$\alpha + \beta = P = 1 + 2 - 15 - 8 + 10 = -10$$

$$\alpha - \beta = Q = 1 + 2 + 3 - 1 + 12 = +17$$

$$\alpha = \frac{P + Q}{2} = \frac{17 - 10}{2} = +3\frac{1}{2} \text{ fringes.}$$

Then the angle at the summit  $A$  of prism No. 2 is larger than  $45^\circ$ , and the hypotenuse face must be retouched by removing more material towards the edge  $D$  than towards the edge  $A$ . This excess of material to be removed is easy to calculate,  $3\frac{1}{2}$  fringes corresponding to a variation in thickness of  $3.5 \times 0.28 \mu = 0.98 \mu$  and the error of the angle, supposing  $AD = 25 \text{ mm.}$ , is

$$\frac{0.98 \mu}{25,000} = \frac{39 \mu}{1,000,000}$$

As 1 sec. =  $\frac{1}{200,000}$  (about) the error to be corrected is 7.8 sec.; the angle  $D$  of prism No. 2 before correction being  $45^\circ 0' 8''$  and the angle  $A$  of the same prism being  $44^\circ 59' 52''$ .

### Verification of Prototype Angles of $60^\circ$ , $120^\circ$ and $30^\circ$

The principles of the bevel gauge method and that of fringes on a proof plane are equally well applicable to the verification of prototype angles of  $60^\circ$  and  $30^\circ$ .

*Verification by Means of the Bevel Gauge.* Set the bevel gauge to an angle of about  $60^\circ$  and place an equilateral prism in it. If the three angles of the prism present the same appearance they must all be equal to  $60^\circ$ , and it is not necessary for this for the bevel gauge itself to be exactly at  $60^\circ$ .

*Verification by Fringes.* Prepare an angle of about  $120^\circ$  and lay it on the proof plane (Fig. 85). Place against this angle an equilateral prism. If it is exactly equilateral it can be turned to permutate its

summits and the same total number of fringes will be found on the faces  $AB$ ,  $AC$  and  $AD$ . If this is not so, the corrections to be made to the  $60^\circ$  angles may be calculated, as has been explained for the  $45^\circ$  angles.

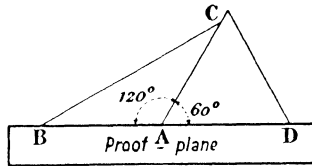

FIG. 85.

Having the exact angle of  $60^\circ$  it can be used for measuring the error of the angle of about  $120^\circ$ . That error measured in fringes is equal to the algebraic sum of the fringes on the faces  $AB$ ,  $AC$  and  $AD$ .

The angle of  $120^\circ$  being exactly realised, it suffices to render the triangle  $ABC$  isosceles to have exact  $30^\circ$  angles. For this one works in the same way as has been described for rendering a right-angled triangle isosceles.

### Verification of an Angle of $15^\circ$ and of its Multiples

Still, by the same method of fringes, one can verify an angle of  $15^\circ$  or one of its multiples, with a precision nearly equal to that of the preceding prototypes.

By juxtaposing on a proof plane (Fig. 86) a prism of  $90^\circ$ , a second prism of  $45^\circ$  and a third of  $30^\circ$ , the supplementary angle is one of  $15^\circ$ .

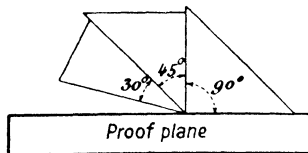

FIG. 86.

One then slides into the space left by the three prisms the  $15^\circ$  prism to be verified and counts the fringes on the five faces, giving to the number of fringes on a face the sign  $+$  or  $-$  according to whether the contact takes place towards the edge  $A$  or towards the opposite side.

If all the prisms had exactly their nominal value the algebraic sum of all the fringes would be nil. If this sum is not nil it measures the algebraic sum of the errors of each component prism. It is then easy to deduct from the total the already known individual errors of the prototypes.

*Example.* Let us suppose the total algebraic sum (for the five faces) is equal to  $-5$  fringes and the  $90^\circ$  standard is correct to  $+2$  fringes, that of  $45^\circ$  correct to  $-3$  fringes and that of  $30^\circ$  to  $+4$  fringes. The total of the errors of the three prototypes is  $+3$  fringes; the error of the  $15^\circ$  prism is then equal to  $(-5 - 3) = -8$  fringes, and it is too obtuse. It must be surfaced afresh, closing the angle by 8 fringes.

### Angle of $30^\circ$

It has been seen above how an angle of exactly  $30^\circ$  can be obtained by the construction of a prism of  $120^\circ$ . The angle of  $30^\circ$  can also be obtained in the following manner.

Having angles of  $90^\circ$  and  $60^\circ$  one has, by difference, the angle of  $30^\circ$ ,

$$30^\circ = 180^\circ - (90^\circ + 60^\circ).$$

If the departures of the prototypes are respectively equal to  $\epsilon$  and  $\theta$  expressed in the number of fringes with the appropriate sign, the error  $x$  made in the angle of  $30^\circ$  is deduced from the total number of fringes  $p$  on the four faces in contact

$$x = p - \epsilon - \theta.$$

One now has all the prototypes necessary in order to verify, by the same procedure, the series of angles in steps of  $15^\circ$ .

$15^\circ$ ,  $30^\circ$ ,  $45^\circ$ ,  $60^\circ$ ,  $75^\circ$  ( $=180^\circ - 90^\circ - 15^\circ$ ),  $90^\circ$ ,  $105^\circ$  ( $=180^\circ - 75^\circ$ ),  
 $120^\circ$  ( $=180^\circ - 60^\circ$ ),  $135^\circ$  ( $=180^\circ - 45^\circ$ ),  $150^\circ$  ( $=180^\circ - 30^\circ$ ),  $165^\circ$   
 ( $=180^\circ - 15^\circ$ ).

### Direct Measurement of Angles

Thus one can, without a model, and commencing simply from the proof plane, assure the construction of a series of standards exact to a few seconds and in steps of  $15^\circ$ . The optical worker can, then, furnish the mechanical constructor with the means of exactly verifying the precision of graduation of the divided circles of his goniometric instruments.

It is in this way that sextants are each provided with a table of corrections to be made to the angles that are read. The corrections are established by the Institut d'Optique by means of a special instrument which utilises, as standards of reference, several standard prisms whose angles are exactly known.

But in the workshop, for measuring or verifying angles, use is made of cruder instruments based generally upon the principle of autocollimation.

### The Principle of Autocollimation

A telescope adjusted to infinity contains in its focal plane (Fig. 87)

a small hole  $E$  illuminated by a prism, which receives the light from a lamp at one side  $L^*$ . The objective  $O$  gives an image of this hole thrown to infinity on the side opposite to the prism. A plane mirror  $M$  placed in front of the objective gives another image, at infinity, of this image. The telescope, being adjusted to infinity sees that second image clearly. In other words, it forms in the focal plane, a small image of the luminous hole, and the position of that image—called a “moon”—depends only on the inclination of the mirror and not on its distance. If the inclination of the telescope with respect to the mirror varies by an angle  $\alpha$  the image turns through an angle  $2\alpha$  about the centre of the objective. By setting the position of the image, for example, by placing it on the intersection of a cross line graticule, the inclination of the mirror is exactly set. If, then, the mirror is removed, to be replaced by another, it will be necessary, in order to bring back the image to the intersection of the graticule, for the second mirror to be placed parallel to the first.†

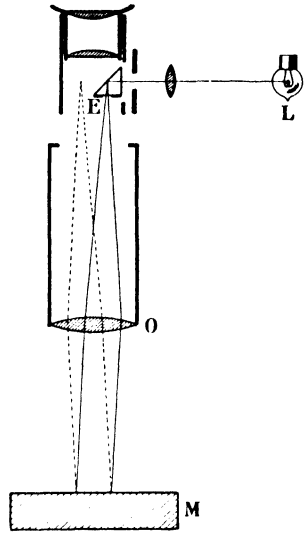

FIG. 87. Autocollimating telescope

The faces of a prism behaving as mirrors, the autocollimation

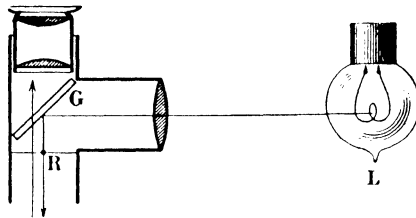

FIG. 88. Means of illuminating cross webs in an autocollimating telescope.

method permits the rapid comparison of two prisms. Place a model prism with one side upon a plane and resting on three little projections

\* In other models of autocollimating telescopes, in place of lighting a small hole by the aid of a prism, one illuminates the reticule  $R$  (Fig. 88) by means of an inclined glass  $G$  which reflects on to the reticule a part of the light coming from the lamp  $L$  and allows the light from the objective to pass towards the eyepiece.

† A fully developed form of autocollimating telescope which embodies a scale giving direct angle readings in minutes over a range of 40 minutes is made by Adam Hilger Ltd., London, and sold as the Angle Dekkor. (Trans.)

on that plane. Adjust the telescope to an exact autocollimation on one face. Replace the model prism by the prism to be verified, disposing it in exactly the same manner. If the two prisms are similar exact autocollimation is preserved; if they are not, the deviation of the image indicates the defect to be corrected.

### Workshop Goniometer

This instrument embodies two autocollimating telescopes with illuminated holes (" moons "). Each telescope is mounted on a plate provided with two screws for adjusting its direction; one of these screws, carrying a little graduated disc rotating beside an index, permits measurements of small angular displacements to be executed.

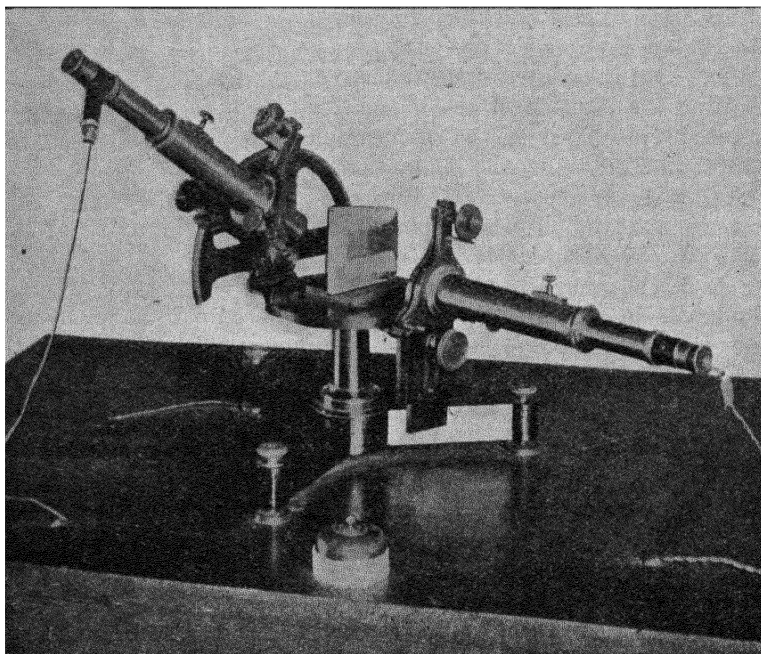

FIG. 89. Workshop goniometer.

The support of the first telescope is fixed; that of the second telescope is movable around a horizontal axis. Fig. 89 shows the first telescope in front of a right angle prism set up for verification of its right angle. The second telescope is in a reserve position and serves for verifying  $45^\circ$  angles when the prism has been rested on the plane by its hypotenuse face.

This instrument permits the rapid control of mass produced pieces which include plane surfaces, such as prisms or parallel plates. For checking prisms, the standard prism is placed on three little projections on the plate and rested against two fixed lugs while one of the telescopes is pointed exactly at the face to be controlled. Then all the prisms to be tested are substituted in succession for the standard prism and the illuminated spot ("moon") of the autocollimating telescope should remain in place. If this is not so the micrometer screw allows of measurement of the angular error of the prism. One is often satisfied to estimate it in diameters of the spot, when the angular value of that spot has been measured. It can be measured by means of the micrometer screw, which allows of calculation of the angle by which the telescope must be inclined in order that the spot, being tangential to the vertical cross line on the right-hand side, may become tangential to it on the left.

Often the angular tolerances are stated as spots, half spots or quarter spots (moon, half moons or quarter moons). In this case no measurements of angle are to be executed; the instrument is used solely as a comparator (see footnote on p. 215, Trans.).

#### Laboratory Goniometer \* (Fig. 90)

When the telescope can be turned round a divided circle one can, after having viewed one face, cause it to perform autocollimation on

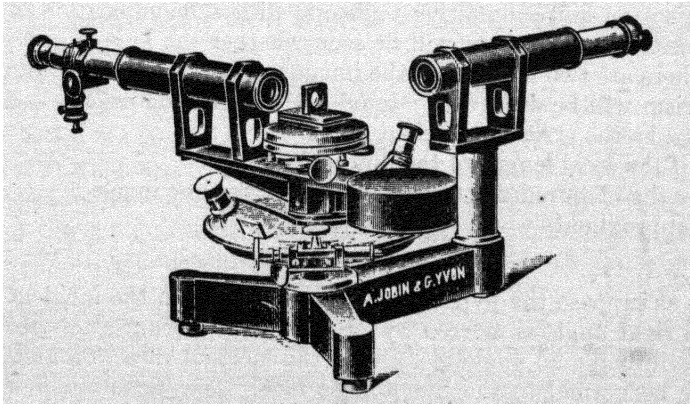

FIG. 90. Laboratory goniometer.

another face, and the angle through which the telescope has turned measures the angle between the two faces, with the precision of which

\* A specially designed goniometer for optical laboratories is made in England by Messrs. Ross, Ltd., and sold by Adam Hilger Ltd. It was described in *Proceedings of the Optical Convention*, 1926. (Trans.)

the instrument is capable. The position of the prism on the table is only determined by one single condition, which must be scrupulously respected. The vertical edges of the prism must be normal to the circle, otherwise one does not measure the right section of the angle but an oblique section. A telescope pointing on a face normal to the angle to be measured allows of verifying that the piece has not slipped on its support.

These principles apply to all models of angle comparators or workshop goniometers.

### Rapid Verification of a Right Angle, without Standards of Comparison

*(The teacher will recapitulate the properties of images given by double reflection.)*

On looking into the hypotenuse face of a right-angle prism the observer sees his own image returned, but he sees only a single image. On closing one eye he sees the pupil of the other one exactly bisected by the edge of the prism, but he only appreciates that exactness with the precision of the naked eye. If, as is usually the case, the prism examined is to become part of a magnifying optical system (prism binoculars or range finder, for example) naked eye precision will not suffice; the experiment must be made while employing a magnification superior to that of the optical system envisaged. If the prism is destined for binoculars of 8 times magnification one places in front of the prism an autocollimating telescope with a magnification of about 12 times. At a glance it will be seen whether the hole is quite round or if there are two images. If the image appears sharp and quite round the prism will be classed as "good for  $\times 8$  binoculars".

Let  $\alpha$  be the error of the right angle,

$f$  the focal length of the objective,

$\epsilon$  the observed displacement of the cross line image;

then approximately

$$\epsilon = 3\alpha f.$$

Let us suppose the hypotenuse face is normal to the incident beam. If the right angle is marred by an error  $\alpha$ , the beam after two reflections will make an angle of  $2\alpha$  with the incident direction and will no longer be normal to the hypotenuse face. The deviation  $\beta$  which it will have after refraction will be such that

$$\frac{\sin \beta}{\sin 2\alpha} = n = 1.50 \text{ approximately.}$$

The angles being very small one can write

$$\epsilon = \beta f = 3\alpha f.$$

By the method of two successive autocollimations on the two faces  $\epsilon = \alpha f$  could have been measured.

The double reflection method is then three times as precise as the method of two separate autocollimations.

When a telescope with an illuminating prism is used for autocollimation (Fig. 87) care must be taken to place the edge of the right angle closely parallel to the direction of the telescope lamp. If the edge were perpendicular to that direction the image would form in the illuminating prism and it would be impossible to cause it to come out into the free part of the field of view of the eyepiece, for tilting the prism about the edge has no effect and tilting the edge in the plane normal to the lamp displaces the image in that plane, *i.e.* parallel to the edges of the illuminating prism. It has already been seen (footnote, p. 215) that there are other models of autocollimating telescopes free from this drawback.

#### EXAMPLES OF EXERCISES WITH THE SPOT GONIOMETER \*

The errors may be measured in fractions of the spot or in divisions of the micrometer screw.

##### 1ST EXERCISE. To Measure the Defect in Parallelism of the Faces of a Plane Glass Plate

Set up for autocollimation. If two spots are seen in juxtaposition, the angle between the faces is equal to half the angular value of the spot.

##### 2ND EXERCISE. To Measure the Angular Size of the Spot

(a) *When the goniometer is graduated.* Set up in autocollimation on a plane so that one of the cross webs is tangential to the spot. Turn the telescope in such a way that the web is tangential to the opposite side of the spot. The telescope has turned through an angle, read on the scale, which measures one half of the apparent diameter of the spot.

(b) *If the goniometer is not graduated.* Take a plate with a noticeable error of parallelism which has been measured in the laboratory. Set up in autocollimation; estimate the fraction of the spot by which the two spots are separated, and deduce the size of the spot from it.

##### 3RD EXERCISE. To Measure the Errors of the Right Angles of a Cube with Parallel Faces

The cube being set against the rest; set up for autocollimation on one of the faces normal to the rest. Turn the cube so as to set the

\* See p. 216.

opposite face against the rest.\* If the spot is displaced by one diameter the error of the right angle is  $\frac{1}{4}$  of the spot.

#### 4TH EXERCISE. Verification of an Isosceles Right Angle Prism

(a) *Verification of the right angle.* Set up for autocollimation on the hypotenuse face, with the prism resting upon one of its cathetus faces. Two images will be seen simultaneously by reflection in the faces of the right angle. These two images would exactly coincide if the angle were exactly a right angle. If they do not coincide their horizontal separation measures three times the error of the right angle. The vertical separation between these images and that reflected from the hypotenuse face measures twice the defect of parallelism of that face and the edge of the right angle.

(b) *Verification of the 45° angles.* Rest the prism on the instrument table by its hypotenuse face; set up for autocollimation on one face of the right angle and then on the other without displacing the telescope. The displacement of the spot measures twice the difference of the two acute angles.

#### 5TH EXERCISE. To Measure the Small Errors in the Angles of a 60° Prism

Let the prism be carried on the instrument table by the face opposite to the angle  $A$  and set up in autocollimation in such a way that the spot is tangential to the horizontal cross web. Repeat by resting the prism on the face opposite to the angle  $B$ . Let  $\pm b$  be the displacement of the spot with respect to the first position it was seen in. Do the same for the face opposite to the angle  $C$ . Let  $\pm c$  be the displacement of the spot with respect to the first position, then:

$$\angle B = \angle A \pm \frac{b}{2},$$

$$\angle C = \angle A \pm \frac{c}{2},$$

$$\angle A + \angle B + \angle C = 180^\circ.$$

From these three equations deduce the values of  $\angle A$ ,  $\angle B$  and  $\angle C$ .

\* The author evidently has a particular goniometer in mind, but the intended method is sufficiently obvious for it to be adapted to other instruments. Thus, if the Angle Dekkor is used the "rest" will be the base plate and the telescope will be in its horizontal position. (Trans.)

### VERIFICATION OF TOOLS

The surfaces of tools, not being susceptible of verification by means of interference fringes as are optical surfaces, cannot be obtained of the same perfection. Certain processes of verification in use in mechanical workshops reveal errors of some microns and this precision is sufficient, since, ordinarily, much better optical surfaces are obtained than those of the tools which have served for producing them. This, as we have seen in the preceding chapters, arises from the fact that a lens, being rubbed successively by wide regions of the tool, cannot fit itself to its local defects and only participates in its general shape.

The methods of test to which one has recourse for verifying tools are:

1st. The examination of the daylight (spaces) which appears between a surface and its template, or between a plane and the bevel edge of a truly straight rule.

2nd. The examination of the points of contact of two surfaces placed together one on the other with some spots of polishing rouge interposed between them.

#### *Examination of the "Daylight" (Space)*

When one applies the truly straight edge of a ruler to a nearly plane surface daylight appears wherever the contact is defective. To habituate the eye to appreciating the size of the faults thus revealed it is a good plan to place between a rule and a plane a little slip of known thickness (*e.g.* 0.01 mm.) and fix in one's mind the size of the space produced. The optician can construct such slips for himself by cementing on a flat tool, but with very little cement, a very thin lamina of steel and smoothing it with another flat tool to bring it nearly to the desired thickness. It is then cut up into several strips whose thickness is measured with a precision micrometer. Those whose thickness is not constant are rejected and the others are standardised. These little calibrated slips are very useful for adjusting certain pieces with a precision of one hundredth of a millimetre.

The daylight produced by a slip of  $\frac{1}{100}$  mm. interposed towards the extremity of a rule is clearly visible, even in proximity to the point at which the rule really touches the surface. This daylight is more precisely appreciated by viewing it with a small magnifying reader, when that reader can be approached closely enough.

In order to verify a flat tool a truly straight rule is rested on it in

contact by one edge\* and it is displaced on it in all directions. The spaces which appear indicate if the surface is convex or concave; they also show local bumps, if there are any.

To verify the generatrices of a cylindrical convex tool a proof plane is rested on it and one looks to see whether a space appears between the tool and the plane in any position of the plane when it is made to roll on the tool.

To test a spherical convex tool or the directrices (arcs) of a cylindrical convex tool use is made of a curvature template. That is a piece of sheet metal in which has been cut, in the mechanical workshop, an arc of a circle of the desired radius. By displacing the template on the convex tool a position is found for which the space is a minimum, or even disappears; this is the optimum position which corresponds to the greatest section.

With a convex template the directrices of a concave cylindrical tool can also be verified.

But in a general way, to verify a concave tool as in verifying the fit

\* The following method can be used for verifying the straightness of a precision straight-edge, making use of an autocollimating telescope such as is used in the workshop goniometer. On a little metal plate, of about 3 cm. side, is cemented a right-angle prism (Fig. 91) on which autocollimation is made by double reflection from the

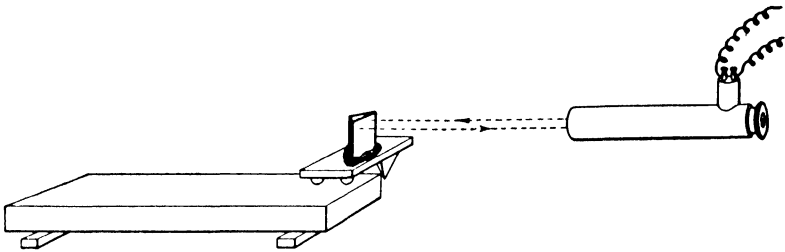

FIG. 91. Testing a straight-edge.

right angle. The little plate rests on the table by one foot and on the face of the straight-edge by two bosses (or balls) which are aligned parallel with the telescope. When the little plate, with its prism, is displaced the back-reflected image remains stationary if the course followed by the two bosses along the straight-edge is truly rectilinear. It rises or falls in following the slopes of the straight-edge if that is curved a little. The advantage of the right-angle prism over a plane mirror is that it is only influenced by the slopes, that is, it is indifferent to small transverse differences in level, and does not demand a rigorously rectilinear movement.

When one face has been tested and corrected, the adjoining face is tested and corrected. The two faces being quite straight the edge which separates them is also straight.

A flat tool can be verified directly in the same way by making a little carriage bearing a prism traverse the sides of a star-shaped polygon traced on the tool. If the tool is perfect the back-reflected image remains stationary during all traversals of the carriage.

of two flat tools or of a concave and a convex tool of the same radius the method of determining the points of contact with rouge is used.

### **Rouge Test**

The grains of rouge used for polishing are from 3 to 6 microns in diameter; they can, then, reveal unevennesses of that order of size when a thin layer of rouge is interposed between the surfaces.

To compare a convex tool with its concave tool, for instance, the convex tool is covered with a little wet rouge which is carefully spread out. Then the concave and convex tools are rubbed together in the same way as if it were desired to surface them. Thus the little balls of rouge are crushed and the tool is covered with a very thin, uniform coating of rouge.

This done, the concave tool is washed and carefully dried. The convex is, for a second time, rested in the concave, giving it a small sliding movement to make the two pieces stick to one another. On separating them, avoiding, as much as possible, making them slide on one another, all the surfaces of contact are seen to appear in rouge on the concave tool; the regions deprived of rouge are those which do not bear on one another.

## CHAPTER VII

### POLARISATION OF LIGHT. CRYSTAL SHAPING

#### POLARISED LIGHT

To give an understanding of luminous vibrations their analogy with waves propagated in water is generally shown. The comparison is much more justified in dealing with polarised light than in the case of natural light. When the undulations caused, for instance, by the successive fall of stones into still water are propagated on the surface of a basin and encounter a cork in it, the cork rises and falls. It is moved by vertical oscillations, which always remain vertical because they are governed by gravity. In the case of natural light, the vibrations do not keep to the same direction. For a horizontal ray they are always contained in a vertical plane perpendicular to the ray but they describe, within that plane, elliptical curves which, in the general case of natural light, are not co-ordinated, presenting their major axes sometimes in a vertical, sometimes in a horizontal direction and most often in any intermediate oblique direction whatever.

A rough comparison can be made between a ray of light and a stretched cord which vibrates with a regularity of about 600 million vibrations per second. If these vibrations are distributed in all directions they represent natural light; if they are all in the same plane they represent polarised light. When a point on the vibrating cord is displaced in a certain direction it can be said that a force draws it in that direction, but it can also be imagined that that force may be the resultant of two others directed, for instance, one upwards and one to the left. If the vertical component is suppressed, there only remains the leftward component, smaller than the resultant of the two components. When the vertical components of all the vibrations are destroyed the ray is said to be completely polarised in a vertical plane.\* By completely polarising a beam of light one then diminishes its intensity by a half.

When a beam of light is reflected by a non-metallic surface (glass, water, oil, etc.) at an incidence of about  $56^\circ$  for glass, the light is polarised in the incident plane and the mirror plays the part of a polariser.

A beam can obviously simultaneously contain polarised light and ordinary light; it is then said to be partially polarised. A beam is

\* Since the remaining component of the vibrations is horizontal the light must be polarised in a *horizontal* plane, not a vertical one. (Trans.)

partially polarised when it has been reflected at an incidence differing from  $56^\circ$  (for glass).

When, after having extinguished all the vibrations perpendicular to a certain plane of polarisation one arrives, by the aid of a second mirror, at the extinction of the remaining vibrations, and in consequence at causing the whole of the light to disappear, the second plane must be perpendicular to the first. The second mirror, since it allows of determining which is the plane of polarisation of the light polarised by the first mirror (called the polariser), is called an analyser.

In the case of polarisation just considered the vibrations being contained in a plane and normal to the ray, the polarisation is said to be rectilinear. But there are also circular and elliptical polarisation. Comparing these again to the vibrating cord they can be said to correspond to the cases where the points of the cord, instead of vibrating in a straight line describe, in vibrating, circles or ellipses.

Light is also polarised by refraction at very oblique incidence, but a single refraction polarises less than a reflection at an incidence of about  $56^\circ$ . That is why the refractions are multiplied by employing piles of 10 to 15 plates, almost parallel and thin, to constitute polarisers or analysers.

### **Birefringence (Double Refraction)**

Among transparent substances there are some which enjoy the same optical properties in all directions; they are said to be *isotropic* (from the point of view of their optical properties). Such substances are fluoric and well annealed glass. Transparent substances which are not isotropic, like the majority of crystals, are said to be *anisotropic*.

*Birefringence* is the property of doubling the rays of light possessed by all anisotropic substances. Light does not travel at exactly the same speed in the doubled rays and these can separate from one another to a very appreciable extent, giving rise to two images. Calc spar, also known as Iceland spar, presents this phenomenon in a striking manner. If a piece of spar (Fig. 92) presenting two natural parallel faces is placed on a sheet of printed paper one observes that all the printed characters appear to be doubled. This is because, from each point on the paper, there arrive at the eye, through the spar, two distinct pencils furnishing two virtual images of that point. Thus, on entering into a birefringent crystal a light ray doubles itself into an *ordinary* and an *extraordinary* ray. The ordinary ray is that which behaves as if it had passed through a plate of glass. The ordinary image of a point seen through a plate of crystal does not shift when the plate is rotated parallel to its faces: but the extraordinary image, that is to say, that formed by extraordinary rays, turns around the other. This phenomenon can be understood in the following fashion. A crystal is an

edifice of molecules geometrically disposed in a perfectly regular manner. It is conceivable that among the alignments of molecules there are some directions in which the luminous vibrations are more quickly propagated than in others. A ray of light falling on a birefringent crystal, instead of continuing to vibrate in all directions, resolves itself into two other rays which are polarised, the one in the plane in which propagation is most rapid and the other in a plane

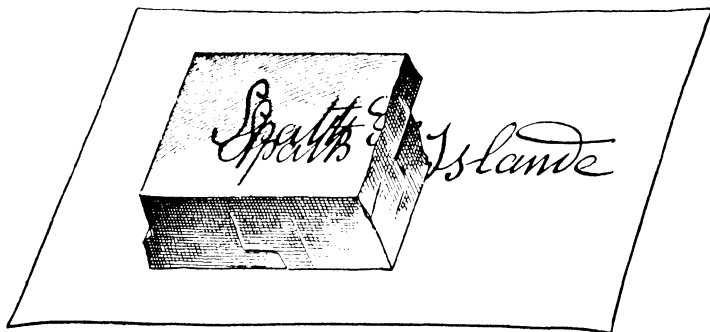

FIG. 92. Refraction of Iceland Spar.

perpendicular to that. These two rays are polarised rectilinearly at right angles; they are the ordinary and extraordinary rays cited above (nevertheless certain crystals, known as biaxial crystals, have no ordinary ray but two extraordinary ones). We shall see, in connection with the cutting of crystals, how these two rays may be separated. If one of the two is suppressed, the ray which remains to leave the crystal is a ray of polarised light. The most used polarisers and analysers are made of suitably cut crystal (most frequently of Iceland spar).

### **Birefringence of Strained or Insufficiently Annealed Glass**

Strained glass, *i.e.* chilled glass and even glass that has been allowed to cool a little too quickly, suffers molecular tensions in its mass which, upsetting its isotropy, make it birefringent. This defect is caused to disappear by heating it again, followed by very slow cooling.\* The effect of birefringence on the images formed by a lens is not generally very pronounced, but it is sufficient to diminish the sharpness of the images. These images, which are sensibly stigmatic when the glass has no trace of strain, are no longer so, and can become very bad,

\* See F. Twyman, *Trans. Soc. Glass. Techn.*, **1**, 61 (1917), and subsequent papers. (Trans.)

when the glass is a little strained or even very little strained. It is possible, however, to detect birefringence by the following artifice.

When a ray of rectilinearly polarised light is made to fall on a piece of glass more or less compressed by a strain or by external pressure, that ray is transformed into two others polarised at right angles to one another. On leaving the glass the two rays vibrating at right angles cannot be extinguished simultaneously by an analyser. The superposition of their vibrations forms elliptical (or circular) vibrations; an analyser can flatten the ellipse but not destroy it. On the other hand, the glass under examination being removed, an analyser crossed at right angles with a polariser gives complete extinction. Thus by placing a glass object between a crossed polariser and analyser, one can judge its state of strain by the appearance of a lightness which is more pronounced as the region explored is less isotropic. In reality, when white light is used, the lightnesses which are observed are coloured because the analyser extinguishes the various component radiations of the light unequally. Fringes denoting the distribution of the strains are even observed when they are accentuated enough.\*

These remarkable phenomena of polarisation are often easily produced, as is proved by the way in which the French physicist, Malus, discovered, in 1808, the polarisation of light by crystals. Observing the sun reflected obliquely by a window in the Luxembourg Palace, it occurred to him to place before his eyes a crystal which he had in his hand and he found that the brightness of the light which he was observing varied considerably when he turned the crystal between his fingers. The sunlight was polarised by reflection in the window and the crystal acted as an analyser.

### Norremberg's Apparatus (Fig. 93)

This apparatus precisely reproduces the conditions of Malus' experiment. It allows of repetition of a large number of experiments on polarised light, and is an indispensable apparatus for optical workshops in which crystals are cut.

It consists, essentially, of a reflecting polariser and an analyser, called a Nicol (from the name of its inventor), which will be described in connection with the cutting of spar. The analyser is at *A*, and is sighted vertically; it can turn around the axis of its mounting.

The polariser is at *B*; it is an unsilvered glass with almost parallel faces inclined at  $35^\circ$  to  $36^\circ$  to the vertical. On the base of the instrument a plane silvered mirror *M* is rested. The light which falls on the lower face of the glass plate *B* is reflected to the mirror *M* and

\*The Hilger Strain Viewer and some other similar instruments by interposing a birefringent plate between polariser and analyser produce a sensitive tint which reveals the presence of strain in an even more delicate fashion. (Trans.)

that which arrives normally to the mirror *M* is precisely that which falls at the optimum incidence of about  $56^\circ$  on the mirror *B*: hence the light reflected towards the analyser is polarised. The glass or crystal to be examined can be placed either below mirror *B* or above it on a plate *P*. A magnifier turning around one of the vertical supports can be interposed in the vertical axis of the instrument. When a crystal is placed under the magnifier it is studied in convergent light.

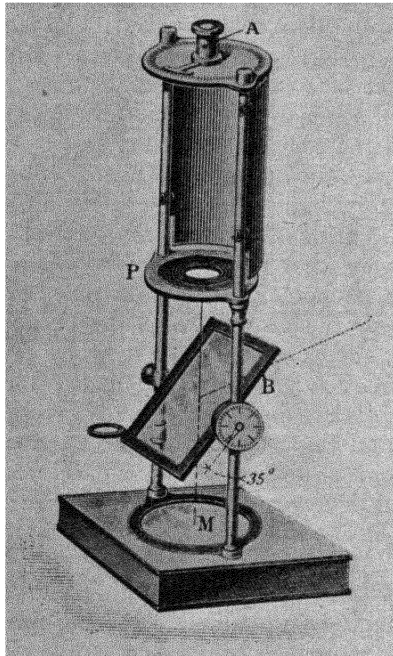

FIG. 93. Norremberg's apparatus.

Norremberg's apparatus is convenient for seeking traces of strain in pieces of glass destined for the manufacture of optical parts or in finished lenses. If a piece to be examined is placed on the lower mirror it is twice traversed by the polarised light, which is reflected in the inclined mirror, and, when the nicol is at extinction, the field is more or less lit by coloured glows in the regions where the glass is contracted by the effect of a too rapid cooling.

The Norremberg apparatus is mainly used for determining the direction of the axes of crystals. The axis is the name given to a certain direction in the crystal around which the symmetry of the optical phenomena is perfect. This direction is related to the geometrical

structure of the crystal. The phenomena of polarisation which can be observed with the Norremberg apparatus permit the axis of a crystal to be rapidly determined.

If a piece of quartz whose faces have been cut perpendicular to the axis is placed on the upper stage of the Norremberg apparatus and if the apparatus is set to extinction with the lens for examination in convergent light in place, the rings and the characteristic cross shown in Fig. 94 will be seen. The arms of the cross do not reach the central

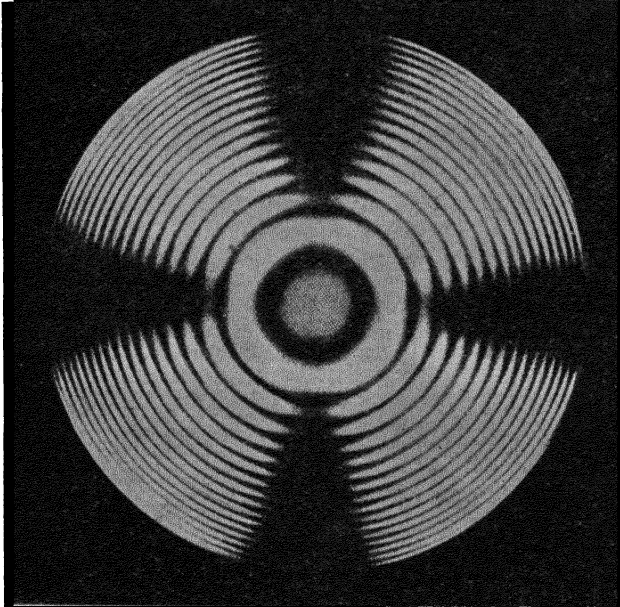

FIG. 94. Cross characteristic of quartz cut perpendicularly to the axis.

Details of the properties of crystals of spar and quartz in polarised light will be found with the interference figures that they form in the *Traité de Polarimétrie* by G. Bruhat, published by the *Revue d'Optique*, Paris.

spot, whose uniform tint varies when the nicol is turned a little. If a piece of Iceland spar is substituted for the quartz an analogous figure is seen which differs from Fig. 94 by the arms of the cross going right to the centre of the field.

If a piece of quartz cut perpendicularly to the axis is placed on the mirror *M* in Fig. 93 and beneath the interposed lens the appearance of Fig. 95 will be seen. The spirals seen there are called Airy's spirals from the name of the English physicist who observed them for the first time. The spirals can also assume the reverse form (Fig. 96) according to the nature of the quartz. Quartz which gives Fig. 95 is

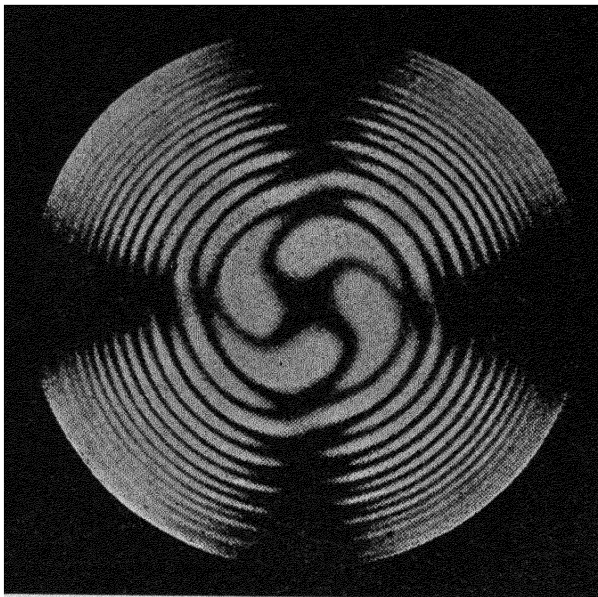

FIG. 95. Airy spirals characteristic of laevo-rotatory quartz.

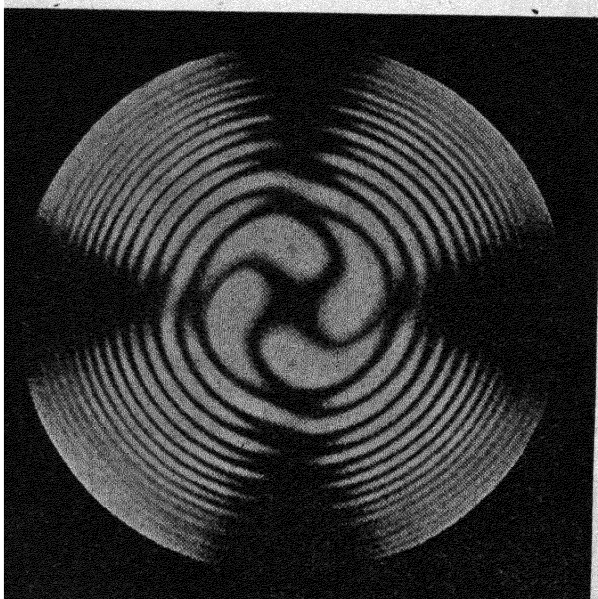

FIG. 96. Airy spirals characteristic of dextro-rotatory quartz.

said to be laevo-rotatory or left-handed quartz; that which gives Fig. 96 is said to be dextro-rotatory or right-handed quartz. As a mnemonic device it may be noted that spirals of the  $\delta$  form are produced by *dextro*-rotatory material.

If, instead of using monochromatic light, white light is employed, the circles of Fig. 94 and the spirals of Figs. 95 and 96 have a rainbow appearance.

If one does not look exactly in the direction of the axis on to the mirror (it suffices for this to tilt the crystal a little) the figures observed become assymetrical and move in a certain direction in proportion to the extent to which the crystal is inclined. In this way one has a convenient means of determining the axis of a crystal.

### Tourmaline Tongs

If a very small piece of crystal has to be examined, the spirals and a very extended cross can still be seen on condition that the eye is placed very near to the crystal. The Norremberg apparatus is less suitable in this case. It is preferable to hold the crystal between the crossed analyser and polariser and to place the eye against the analyser.

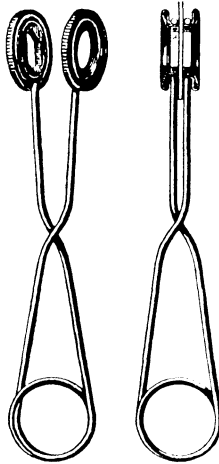

FIG. 97. Tourmaline tongs.

A small apparatus in common use can sometimes replace crossed nicols; it is the tourmaline tongs (Fig. 97). Tourmaline is a mineral, which, cut as will be explained later, polarises light. The two pieces of tourmaline which constitute the fingers of the tongs are set to extinction, that is to say that each of them polarises the light in a plane normal to the plane of polarisation of the other.

Crystals of different minerals offer examples of very varied struc-

ture, although they are always geometrical and regular. According to their structure the crystals effect the light in different ways. Certain of them present phenomena not yet referred to and which the optician needs to know, as scientists and manufacturers use them by means of specially cut crystals. Rotatory polarisation is notably concerned.

### Rotatory Polarisation

We have seen what the plane of polarisation is. Certain substances, among which is quartz, have the property of turning the plane of polarisation to right or left. The angle through which the plane of polarisation turns is proportional to the thickness of the substance which is traversed. Substances which turn the plane of polarisation to the right are called dextro-rotatory (Fig. 96); those which turn it to the left are called laevo-rotatory. A sugar solution has rotatory power which increases in proportion as the concentration of the sugar increases. As a result, by measuring the angle through which the plane of polarisation has turned after traversing a known thickness of a solution of sugar, one determines the concentration of the sugar in the solution. There are some dextro-rotatory sugars and others which are laevo-rotatory. The apparatus by which they are measured is called a saccharimeter. An optical workman should know how to cut the crystals from which the optical elements are made.

### CRYSTAL CUTTING

Crystals are minerals whose constituent elements form perfectly geometrical structures taking the shape of regular polyhedra (cube, rhombohedron—lozenge shaped faces—hexahedron, octohedron, etc.). The planes parallel to the faces of the polyhedron are called cleavage planes; the mineral is more easily split along the cleavage planes than along any other planes. Diamond itself, although very hard, is cut fairly easily by the aid of a simple razor blade, properly oriented, which is given a sharp blow. Other crystals are very easily cloven with the finger nail (gypsum, mica, etc.).

When a crystal presents acute angles and obtuse angles (lozenge shaped faces, for instance) it is because the disposition of the molecules is not the same in the various directions. There are some crystals which present one or two privileged directions, for which certain symmetries appear. They are called uniaxial or biaxial, but they are one and all anisotropic, which signifies that they do not possess the same properties in the same degrees in all directions. Only crystals of the cubic system are optically isotropic; the three sides of a cube being equal and perpendicular one to another, the molecular structure of a cubic crystal appears the same along whatever side of the cube it is

considered. Moreover, it can be demonstrated that the action of such a crystal upon light is the same in all directions; there is no privileged direction.

In uniaxial crystals every section which contains the axis is called a principal section, and every section normal to a natural or artificial face and parallel to the axis is known as the principal section of that face. When an incident ray is in the principal section of a cleavage face, the ordinary and extraordinary rays both remain in that plane.



FIG. 98.

It is the only case in which the extraordinary ray is in the plane of incidence. When a line parallel to a principle section of the cleavage face (Fig. 98) is observed, the two are in the prolongation of one another. It is by means of this observation that a principal section of cleavage may be determined.

Only pieces of crystal which are very pure and free from defects can be employed in optical work. Some defects are easily visible without instruments. "Flocules" are dull or brilliant; the first are formed of particles of mineral which have remained amorphous or of particles of a different mineral. An agglomeration of little dull flocules is called "snow". The brilliant flocules are "vacuoles", or little spaces in the interior of the crystal; large vacuoles generally contain water.

Vision is often interfered with by very fine filaments. These are capillary tubes, isolated or combined in rectilinear bundles which are almost parallel. With a good magnifier their central cavity may be discerned.

The most dangerous defects are twin crystals ("Macle") for they are not always visible to the naked eye. A piece of good crystal is as if formed from an infinity of tiny crystals welded together with their axes all parallel. But it can happen that certain of these elementary crystals are welded with their axes not parallel to those of the neighbouring crystals. These are twin crystals ("Macle"). The welding has been done, face against face, but the faces that are in contact are not those that should be so in a normal piece of crystal. The welding of the twin crystals is sometimes so strong that one breaks the piece more often than one causes the weld to yield in the desired region.

A crystal must be examined with a good polarised light apparatus if one wishes to eliminate twin crystals and a waste of nearly 50 per cent. can be found in a batch of quartz sold as pure, that is to say, showing neither snow, vacuoles nor visible impurities. Twin crystals which are but slightly visible are tolerable for optical work which is not to serve in polarisation apparatus; they cannot be tolerated, for example, in the construction of saccharimeters.

Still other defects of special appearance that must be eliminated are encountered, for example bands forming veils, which are impurities deposited at the moment of crystallisation. The method of examination indicated in Chapter I (Fig. 6) for the detection of veins in the interior of plates of glass is advantageously applied to the examination of crystals.

When, after a meticulous examination, all the defective parts have been removed from a piece of rough crystal (called a "canon"), generally oblong in shape, there remains a cleaned canon from which optical parts may be cut.

Before cutting the "canon" the first operation is to determine the direction of its axis (or axes) for, according to the part to be constructed, it will be necessary to cut it parallel or perpendicular to the axis. When the "canon" is large the direction of the axis can almost be seen from the form of the facets and by the striae (see p. 237). A facet almost normal to the axis is provisionally cut on each extremity of the "canon", and on placing it in the Norremberg apparatus with the faces presented horizontally an almost symmetrical figure is seen. The symmetry of the figure can be improved by modifying the inclination of the "canon"; it is proved to be perfect when on causing the "canon" to revolve around a vertical axis no change of aspect in the characteristic figure of the axis is seen.

The position of the "canon" is registered by little blocks placed on the silvered mirror. The faces which should be cut perpendicular to the axis must be parallel to the mirror, *i.e.* to the lower edges of the blocks. In general it is not necessary to determine the direction of the axis with extreme accuracy; it corresponds to a maximum perfection of symmetry and in the neighbourhood of a maximum a slight angular departure is not very sensitive.

Nevertheless, there are some cases where particular precautions are necessary for determining the direction of the axis fairly exactly. The most delicate case is that of a small piece of crystal whose cleavage faces are too slightly indicated for the approximate direction of the axis to be deduced from them. In this case the crystal must be immersed in a liquid which has nearly the same refractive index; thus for quartz, chloro-benzene can be used for the liquid. Rough or unpolished surfaces become transparent, and if the index of the liquid

and its colour are exactly those of the crystal it will even become invisible. Its presence may be recognised by the polarisation phenomena which it produces. The tube containing the liquid and the crystal being placed, for example, in the Norremberg apparatus the crystal is turned in the liquid until the figure characteristic of the axis appears. When the symmetry of this figure is perfect, it only remains to mark the direction of the axis on the crystal. When a large " canon " presents no facet or cleavage mark approximately indicating the direction of the axis the simplest thing is to detach a chip from it and determine the axis of that chip as has just been described; the chip is then replaced on the " canon ". In this way the direction of the axis of the " canon " is known closely without recourse to the immersion of the " canon " itself.

The best means of marking the axis is to cut a facet perpendicular to the axis. There are special pieces of apparatus for aiding this marking. In default of such apparatus one can proceed in the following manner, which is as suitable for " canons " as for very small pieces of crystal.

Insert the crystal in a glass block thinner than the crystal and of the shape of a ring or a frame. Fix it temporarily to the frame with soft wax at the height of the place at which the facet is to be cut. Place the whole in the polarisation apparatus, the ring shaped block resting on two other equal blocks placed symmetrically and resting on the stage of the apparatus normal to the axis of the analyser. Profiting by the malleability of the soft wax, incline the crystal in its ring until the characteristic figure of the axis is obtained. Remove the crystal surrounded by its ring and fix them firmly to one another in the relative position which they occupy, using for this Plaster of Paris or hot cement, so long as the crystal is not damaged by heat.

It now remains to true the facet by grinding the crystal to the height of the block, then to smooth it without cutting into the block and finally to polish it and the block together.

In working a crystal its hardness must be taken into account. It is known, indeed, that abrasives must be chosen according to the hardness of the piece to be worked. The abrasives must " bite " without penetrating deeply; hence the most biting abrasives must be reserved for the hardest materials and the pressure must be regulated in relation to the hardness of the surface to be worked.

There are tables giving the hardness coefficients of various crystals. The hardness, again, depends on the orientation of the crystalline face with respect to the axis, thus fluorite cut in a plane inclined to the plane of cleavage takes a better polish than if its cut were in the cleavage plane, which is a proof of a greater hardness in the first case. The most used crystals can be arranged, as follows, in order of increas-

ing hardness: talc (mica—much the softest), gypsum, calc-spar or Iceland spar, fluorite, feldspar, quartz, topaz, corundum, ruby and diamond.

The best methods of surfacing for each crystal will have to be studied but that study is outside the scope of this book. Most of the rules of surfacing for glass apply in the surfacing of crystals (blocking of small pieces, employment of blocks (or protectors), etc.). In the following only some indications concerning the working of the crystals most used in optical work will be found.

### Quartz

This is crystallised silica. Where quartz is pure it is more transparent than crown or crystal glass; but there is black, smoky, rose or green quartz, according to the impurities it contains. In optical work only colourless quartz free from defects is employed. Brazilian quartz is especially sought after. Cut perpendicularly to the axis, quartz is used for making lenses of instruments which must admit ultra-violet rays, since it is more transparent than glass to the radiations of that region of the spectrum. It has also been employed in spectacle making (see Chapter I, p. 2), but for this use its special transparency is a defect, for ultra-violet radiations fatigue the sight. As has been shown on p. 232, there is right-handed or dextro-rotatory quartz and left-handed or laevo-rotatory quartz, which can be distinguished by the images which they give in Norremberg's apparatus.

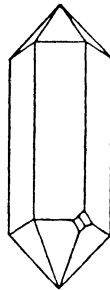

FIG. 99. Quartz crystal.

The typical quartz crystal is an hexagonal prism surmounted by two pyramids (Fig. 99), but it is rarely that this type appears. Little truncations often appear at the base of the pyramids, like the two shown in Fig. 99; when they are disposed as in the figure they characterise right-handed quartz.\* If they are disposed, in relation to the

\* In actual fact, these facets are not accidental, but are a true part of the crystalline structure and always appear on a fully developed crystal. (Trans.)

axis, in a manner symmetrical with that shown in the figure they denote left-handed quartz. Both arrangements are sometimes found in a single specimen, it is rarely that a crystal presents the same crystalline arrangement throughout, and twin crystals are the most frequent proof of this. A rough "canon" of quartz generally presents transverse striae normal to the axis. Using these striae as guides, the two extremities of the "canon" are sawn with parallel cuts which will serve to determine the direction of the axis more exactly. Sawing is done, for preference, with the bow saw with coarse emery, or, for faster working, with No. 80 carborundum. If the circular saw is employed one must go slowly in order not to overheat the quartz, which is liable to chip with slight but rapid variations of temperature, and the water and emery which are used with the circular saw can cause dangerous cooling. It is remarkable that, quartz (crystalline silica) being thus sensitive to temperature variations, fused silica should be, so to speak, insensitive to them. Indeed, one can heat a fused silica object in a flame and directly afterwards throw it into cold water with no risk of breaking it.

The two trial faces being sawn they are trued with No. 3 emery.

To avoid polishing the trial faces they are rendered transparent by covering them with a thin layer of Canada balsam dissolved in benzene, on which a strain free plate of glass (crown or flint for example) is applied. The "canon" can thus be examined on the Norremberg apparatus to determine the axis by the method already indicated. When the "canon" is placed so as to produce the characteristic image the little plate of glass on the lower end is not exactly parallel to the silvered mirror. This slope is adjusted by means of a small block, and this block indicates in what direction and by how much it is necessary to retouch the trial faces in order to render them normal to the axis. After retouching, the canon is again tried on the Norremberg apparatus until complete satisfaction is obtained.

Polishing is done as for glass (paper and tripoli or pitch and polishing rouge). One can also use putty-powder on a brass tool.

A final examination on the Norremberg apparatus after polishing allows twin crystals and other but slightly visible faults to be sought.

The canon can be cut up in sections parallel or perpendicular to the axis. The operations of sawing, smoothing and polishing do not demand any special new precautions.

Quartz being harder than glass, No. 3 emery gives nearly as fine smoothing as No. 10 emery does on glass. Trueing is, then, done with No. 3 emery, and no finer emery than No. 15 is used. In order not to risk breaking the quartz by heating and cooling, the work must be conducted fairly slowly.

### Piezo-electric Quartz Plates

A new industry which utilises carefully cut plates of quartz has been developed; it is that of piezo-electric plates. These special plates are employed in radio apparatus and in ultra-sonic generators used, notably for submarine signalling.\*

The term piezo is taken from a Greek verb which means "to press". When a piezo-electric quartz plate is submitted to an electric action it contracts in such a way that, by submitting such a plate to electrical oscillations, it is made to vibrate; it emits vibrations which could be audible if the oscillations were not too rapid, but they are not usually heard because the sound is too shrill for the human ear to be able to perceive it.

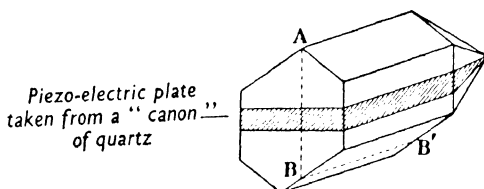

FIG. 100.

Piezo-electric plates are cut perpendicular to the bisecting plane  $ABB'$  of any one of the angles of the hexagonal prism which can be isolated in the canon of quartz (Fig. 100) and parallel to the optical axis. There are, then, three ways of cutting a piece of quartz up into piezo-electric plates—three directions perpendicular to which the plates can be cut; these three directions are called the electrical axes of the quartz. The plate being cut as optical work is cut, must still be submitted to an electrical test and be retouched according to the indications given by the electrical laboratory.

These plates can only be taken from perfectly homogeneous pieces, pure and not presenting the double character of right- and left-hand quartz such as is sometimes encountered (see p. 233).

Their vibratory period being a function of their thickness they must be cut with extreme precision to realise exactly the desired thickness; the precision demanded should attain the micron. As the plates are generally used unpolished they cannot be measured directly by optical methods; in this case one is usually contented with high precision mechanical instruments which do not attain the precision of a micron.

\* As well as in certain television systems. (Trans.)

### Calcspars or Iceland Spar

This is a natural carbonate of lime crystallised in a rhombohedron. Pieces are detached from it by cleavage. Pieces which are good enough for making optical parts are rare; they may only be obtained by meticulous selection.

Calcspars can yield, by cleavage, a solid  $ABCD A'B'C'D'$  (Fig. 101) comprised of six equal lozenges. At  $A$  and  $A'$  are three equal faces of angular aperture  $101^\circ 55'$  and three angles of  $105^\circ 5'$ . The diagonal  $AA'$  equally inclined to the faces is the axis of the crystal. The

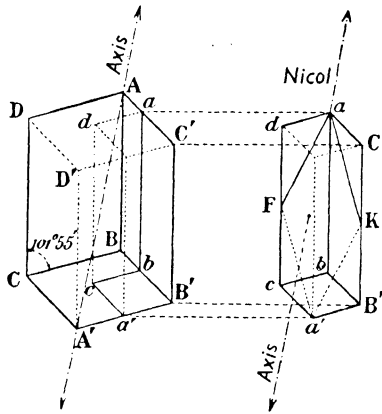

FIG. 101.

various physical properties of the crystal are the same in all directions normal to the axis; it results from this that at infinity in the direction of the axis there is a centre of symmetry of the figures produced at infinity by the phenomena of polarisation.

The two ordinary and extraordinary rays both being polarised at right angles, a piece of spar can be transformed into a polariser (or analyser) on condition that one of the two rays is eliminated. The problem was fairly delicate for the two rays remain very close to one another so long as one does not make them traverse a very great thickness of material. The English physicist Nicol resolved the problem in an elegant manner and his polariser-analyser is the most usually employed.\*

\* There are, however, several square ended polarising prisms whose popularity is considerable. Among these the Glan-Thomson and the Green analyser may be mentioned. (Trans.)

**Nicol**

This is how a nicol is made. A parallelepiped  $add'C'a'cbB'$  (Fig. 101) is cut out by cleavage. Its edges  $abcd$ , etc., are 3 to 3.5 times longer than the transverse edges. This parallelepiped is sawn along a plane making an angle of  $22^\circ$  with the edge  $ab$ , cutting the edges  $cd$  and  $B'C'$  at their centres. This section  $aKa'F$  is a long lozenge. Fig. 102 shows this sawn section turned round and the projection of the nicol in a plane normal to that section. To guide the sawing and to support the crystal, which might chip under the saw, the angle  $ab$  is enclosed in a template called a "swallow" whose cut makes an angle of precisely  $22^\circ$  with  $ab$  (Fig. 101), sawing is done along the cut. The two faces of this section, as well as the face  $a'cdB'$  and the opposite

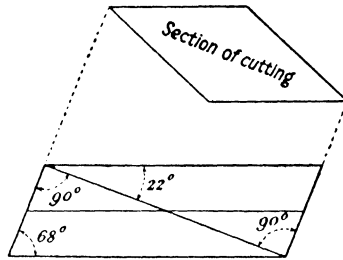

FIG. 102. Nicol.

face are carefully surfaced, the two pieces of the parallelepiped are reunited on one another, as before sawing, but separated by a thin layer of Canada balsam. The surfaced faces thus make a small angle with the original faces obtained by cleavage. The entrance and exit faces are cut normal to the plane of the diagonal section  $aa'$ , and make, consequently, an angle of  $68^\circ$  with the edge  $ab$  (Figs. 101 and 102). The large faces are covered with a coating made of a mixture of lamp black and a gum of high refractive index such as the resin of aloes ( $n_D = 1.634$ ) or balsam of Tolu ( $n_D = 1.628$ ).

Nicols of rectangular profile are also made, whose oblique section cut normal to the axis makes an angle of  $17^\circ$  (instead of  $22^\circ$ ) with the longitudinal faces. The angle of  $17^\circ$  requires the replacement of Canada balsam by linseed oil, whose refractive index of 1.485, lower than that of Canada balsam, is more favourable.

The quality of a nicol, and of the other polarisers described later, depends greatly on the quality of the exit face; the slightest scratches, the least grains of dust, appear as bright lines or points when an observation is made through a second nicol set for extinction. On account

of this a nicol must never be wiped with a duster but dusted with a very soft brush.

The nicol functions in the following way (Fig. 103). A ray falling parallel to the long edges is split in two at the point of incidence. The ordinary ray, encountering the balsam layer at a sufficiently grazing incidence for it to be totally reflected, is lost in the blackened sides. The less deviated extraordinary ray alone traverses the nicol and passes out parallel to its entrant direction but a little displaced.

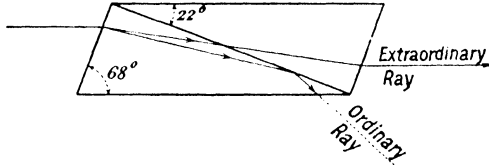

FIG. 103. Path of rays in a nicol.

The elimination of the ordinary ray by total reflection results from the judiciously lengthened form of the nicol. In order to understand it properly the law of total reflection must be recalled. When a ray encounters a refracting surface at an incidence  $i$ , the angle of refraction  $r$  is given by the expression

$$\frac{\sin i}{\sin r} = n,$$

$n$  being the refractive index of the second medium (glass or crystal) with respect to the first (air, glass or crystal). If the incidence is supposed to be grazing, *i.e.*  $i = 90^\circ$ , then  $\sin i = 1$  and  $\sin r = 1/n$ . On reversing the path of the light rays, a ray falling from the second medium on the refracting surface at an angle whose sine is  $1/n$  passes into the first medium tangentially to the surface. All rays which are more inclined to the first medium do not pass through at all and are completely reflected. The angle whose sine is  $1/n$  is the angle of total reflection. Thus total reflection can only occur in the more refringent medium. The refractive index of spar for the ordinary ray is 1.66, but for the extraordinary ray, that which is called the "extraordinary index" varies from 1.49 to 1.66 according to the inclination of the ray in relation to the axis of the crystal.

The refractive index of Canada balsam is 1.53. It results from these figures that, if the second medium consists of Canada balsam and the first of spar, there can be no total reflection for the extraordinary ray, when it is sufficiently inclined to the axis of the crystal for the so-called extraordinary index to fall between 1.49 and 1.53; under this con-

dition, which is realised in the nicol, the extraordinary ray always passes through. It is not the same for the ordinary ray; the index of spar with respect to balsam is  $\frac{1.66}{1.53} = 1.08$ . There is total reflection when the angle of incidence at the balsam has for sine  $\frac{1}{1.08} = 0.925$ .

This is an incidence of about  $67^\circ$ . For all higher incidences only the extraordinary ray passes through. For lesser incidences a part of the ordinary ray also passes through and upsets the effect of the extraordinary ray. The variations of incidence which allow a pure polarised ray to traverse are from about  $67^\circ$  to  $90^\circ$ . The extreme rays spread themselves out yet a little further by refraction on leaving the crystal. This final spreading out of the polarised rays leaving the polariser is called "the field of polarisation". For the nicol the field of polarisation is about  $29^\circ$ , but one cannot extinguish it simultaneously throughout its whole extent. The field of polarisation varies for different types of polariser from  $6^\circ$  to  $34^\circ$  (Thompson prism).\*

It is not absolutely necessary to have recourse to Canada balsam for eliminating the ordinary ray by reflection. The layer of balsam can be replaced by a thin plate of air and an incidence such as produces the total reflection of the extraordinary ray can be chosen. In the best conditions of direction with respect to the axis of the crystal total reflection takes place:

1st. For the ordinary ray at an incidence whose sine is  $\frac{1}{1.66} = 0.603$ , that is an incidence of  $37^\circ$ .

2nd. For the extraordinary ray at an incidence whose sine is  $\frac{1}{1.49} = 0.672$ , that is an incidence of  $42^\circ 15'$ .

### Foucault's Prism

The field of a polariser with a film of air is much smaller than that of the nicol, but, to obtain a favourable incidence, it is necessary that the cut section of the crystal shall be much less extended than that of the nicol ( $54^\circ$  with the entrance face); it results from this that the polariser is much shorter than a nicol, and that it is the least expensive of all spar polarisers. It was invented by Foucault and is called Foucault's prism, or air separation nicol (Fig. 104); its field is only  $7^\circ$ .

Besides the inconvenience of a small field of polarisation, which practically prohibits its use in convergent light, there is that of multiple reflections in the plate of air. Nevertheless, it is used in preference to

\* This prism is little employed because its construction gives 8 times as much waste as that of the nicol (84 per cent. of the crystal used). The long edges are perpendicular to the crystallographic axis, which is parallel to the layer of balsam, which is inclined as in the nicol.

the nicol for work with ultra-violet light for the balsam in the nicol absorbs radiations of that sort.

Balsamed nicols or nicols with air separation, being made by cleavage, leave hardly any waste crystal. That is a much appreciated advantage for good quality spar is rare and expensive. All other polarisers of spar

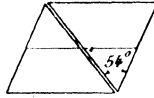

FIG. 104. Foucault prism or nicol with air separation.

are much more onerous and give cutting wastes which can reach 85 per cent.

Unfortunately, in nicols, the exit pencil of light is slightly displaced with reference to the entrant pencil. To avoid that inconvenience in expensive polarisation apparatus, one substitutes for the entry nicols other spar prisms which could be called prisms *de luxe*.

#### Glazebrook's Prism

Among these prisms, the one most frequently employed (sic) is Glazebrook's prism (Fig. 105). This prism gives a more complete and uniform extinction than the nicol and its field of extinction is larger.

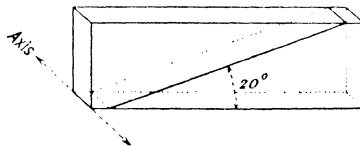

FIG. 105. Glazebrook prism.

The two pieces are generally cemented with Canada balsam but the balsam can be replaced by certain oils to increase the field. The obliquity of  $20^\circ$  indicated in the figure is not essential. With a smaller angle the field is larger. Glazebrook prisms have been made with a field of  $36^\circ$ .

#### Glan's Prism

This is, one might say, an air separation Glazebrook, as the film of balsam is replaced by a less oblique film of air. It follows that the Glan prism is less dear than that of Glazebrook, but it has a less extended field of polarisation ( $7\frac{1}{2}^\circ$ ).

For making nicols, precise determination of the direction of the axis of the crystal is not indispensable for the prisms are mainly cut by

cleavage. It is not the same for most of the other spar prisms since their faces are oriented according to the direction of the axis as in the Glazebrook prism. Such prisms are shown in Fig. 106.

### Rochon, Wollaston and Sénarmont Prisms

These prisms are employed in measuring instruments with double images (the angle of duplication, being known, serves as a standard of measurement. For example, if the two images of a surveying pole are superposed, end for end, the distance of the pole can be calculated from the angle of duplication).

These prisms are made in Iceland spar or in quartz, according to whether a large or a small separation of the images is required. The angle of the face of separation of the two prisms with the entrance

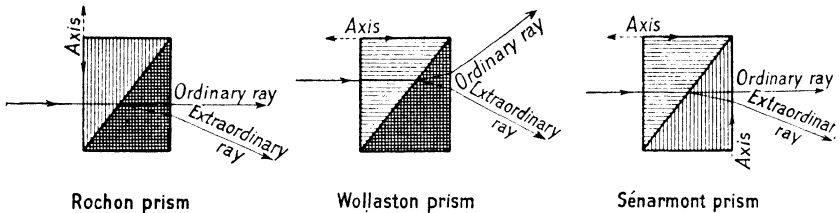

FIG. 106.

*N.B. The grey triangles are sections perpendicular to the axis.*

and exit faces is calculated according to the separation to be obtained. The first Rochon prisms were of quartz, and Fig. 106 indicates the path of the extraordinary ray in the case of quartz (it would be deviated upwards in the case of spar). The separation of the rays is much amplified in Fig. 106.

When the shape of the prisms is trued according to the cleavage faces, their orientation can be rectified according to the direction of the axis. The Norremberg apparatus should be consulted for this; Fig. 94 gives the appearance of the cross characteristic of the axis of spar cut perpendicularly to the axis.

The hardness of the crystal being variable with the direction of the axis in relation to the surface to be cut, the surfacing must be done accordingly. The faces perpendicular to the axis are much the hardest and give sharply cut edges. The softest surfaces are those in the cleavage planes; these are also the ones most liable to split. The surfaces parallel to the axis are less fragile but, nevertheless, they must be treated delicately to avoid chips. It is very difficult to cut a plate of spar parallel to the axis and only 0.2 mm. in thickness, while the operation is relatively simple when a plate perpendicular to the axis is concerned.

Spar is sawn as glass is, but with finer emery (No. 3).

Roughing is done with No. 3 emery, and trueing proceeds with finer emeries down to No. 10, then smoothing is done on a brass flat tool with Nos. 15 and 20 emeries. Certain opticians finish off the smoothing with a pass with pumice powder. A polish with cloth and rouge suffices to clear the surfaces for finding the axis on the Norremberg apparatus. But for the final polishing of the surfaces, especially for the polishing of surfaces inclined to the axis, it is necessary to polish with putty powder on very fine velours stuck with pitch on to a flat tool. There are also some tools which dispense with sticking on the velours. The velours is clamped by a metallic ring on the circumference of the tool and rests on a brass disc laid on the tool. Screws which pass through the tool press on the lower surface of the disc and raise it, stretching the velours: it is a sort of stretcher. There are also fine taffetas which can replace the velours. One can still obtain a good polish by using a pitch polisher in place of the velours polisher, but this method is more delicate.

The pressure to be exercised to make the abrasive bite is less than is suitable for working glass. When suitable pressures have been found for smoothing and then for polishing a surface normal to the axis lighter pressures are employed for surfacing oblique faces and especially for surfaces parallel to the axis.

The faces normal to the axis are opposite to the obtuse angles of the crystal; it results that little obtuse particles can detach themselves fairly easily from the surface, because they are not deeply welded. That is why, although the faces are nearly as hard as flint glass, they must be surfaced more delicately. For the same reason the polished surfaces must be treated cautiously; they should be cleaned with chamois skin, only pressing lightly. For prudence, protective plates of glass are sometimes stuck to surfaces normal to the axis.

### **Fluorite or Fluorspar**

This is a natural fluoride of calcium crystallised in the cubic system. Its colour is most frequently violet, but one encounters samples of fluorite of various colours and also finds some colourless samples. A meticulous examination is required for eliminating the defective parts of each piece of crystal; to this end one proceeds as in the examination of plates of glass, after having polished two faces parallel so as to see through the crystal properly.

Fluorite is valuable for the construction of numerous laboratory instruments on account of its great transparency to ultra-violet rays: its transparency extends still further into the ultra-violet spectrum than that of quartz. Moreover, its dispersive power marries well with that of quartz for forming combinations of achromatic objectives

which transmit the ultra-violet; consequently it is of value for the photography of spectra which extend into the ultra-violet.

As fluorite is an isotropic substance (cubic crystal), it could be cut in any direction whatever. It is, nevertheless, preferable to cut it so that none of the surfaces to be polished is parallel to the cleavage planes, for a better polish is obtained on faces inclined to them than on the planes themselves. This seems to result from variations of hardness with the direction of the cut in spite of the optical isotropy of the material.

Fluorite is a crystal hardly harder than Iceland spar, and it may be worked in the way already described for spar. It is preferable to polish on fairly soft pitch, *i.e.* pitch containing a small excess of oil of turpentine, employing, of course, as abrasive, putty powder suspended in water. It is necessary to rub without pressing too much and without going too quickly, for fluorite splits fairly readily and is much more sensitive than is quartz to changes of temperature.

### Rock Salt

This is sodium chloride (common salt) which is found in large transparent crystals in salt mines. These crystals belong to the cubic system; it is, then, an isotropic material. It is used in laboratories on account of its transparency for infra-red rays.

These crystals are generally tinted, but some of them are found perfectly colourless.

This salt, being very hygroscopic, must be kept protected from humidity. The rough pieces are put into well stoppered and sealed bottles, and the empty space around these pieces can be packed with well dried softwood sawdust.

To fashion optical parts, parallelepipeds are sawn off from which prisms or lenses can be cut. Cleavage is dangerous; in cleaving there is a risk of breaking into many pieces the piece which it was wished to cut into two.

It is indicated that water should not be used for surfacing but a little of it can be used for roughing and trueing, on condition that these operations are carried out very rapidly. Large emeries, which would produce cleavages, must never be used. Smoothing is done on brass tools with fine emeries, down to 20 minute emery, but moistening them with alcohol (or turpentine).

Polishing is as has been described for Iceland spar but replacing water with alcohol. If one polishes on pitch it must be very soft. Polishing only takes a few minutes.

To protect the finished surfaces from humidity and prevent the action of the air from tarnishing the polished surfaces the pieces are covered with a thin layer of varnish, which must be dissolved off in

alcohol or ether at the moment of use of the piece, if the varnish is not transparent to the radiations which it is desired to study with the aid of rocksalt. The action of the air can also be avoided by temporarily sticking small protective plates of glass on the rock salt surfaces.

The finished pieces are kept, like the rough pieces, in well dried, hermetically stoppered or sealed bottles.

### **Tourmaline**

Tourmaline is a natural borosilicate of alumina and several other bases, which crystallises in rhombohedra. It is generally dark green in colour. There are also samples which tend towards violet or red. This substance is used for the construction of the polariser-analyser known as "tourmaline tongs" (p. 231). It has, in fact, the curious property of being unequally absorbent of the ordinary and extraordinary rays. The ordinary ray which has traversed more than 2 mm. thickness of tourmaline is almost completely extinguished while the extraordinary ray remains quite visible. A plate of 2 mm. cut parallel to the axis constitutes a polariser or an analyser.

The direction of the axis cannot be determined as it is for quartz, because, cut perpendicularly to the axis tourmaline extinguishes both ordinary and extraordinary rays almost completely if the thickness of the crystal which is traversed exceeds 1 mm.

Fortunately the direction of the axis is marked on the faces of the crystal by striae parallel to the axis. Plates of about 2 mm. thickness—thicker or thinner according to the transparency of the sample—are cut parallel to these striae.

The technique of surfacing is the same as that for quartz, but greater precautions are necessary in order that the crystal may not split.

To avoid breakage of these fairly fragile plates they are often sheathed with little plates of glass, facilitating mounting. The direction of the axis is marked on each plate, for tourmaline tongs consist, essentially, of two plates whose axes should be crossed. The simplest indication consists in cutting the plates in a rectangular shape whose large sides are parallel to the axis. Tourmaline has the drawback of adding its own colour to the polarisation colours.

### **Mica**

Mica is a transparent mineral (biaxial crystal) which it is particularly easy to cleave. A light ray which traverses it splits into two others which do not pass through the crystal with the same velocity. The one takes a retardation relative to the other which is proportional to the thickness traversed. Plates of mica which give differences of travel of  $\frac{1}{4}$  or  $\frac{1}{2}$  wavelength between ordinary and extraordinary rays coming from an incident ray traversing the plate normally, are used in the

laboratory. They are called  $\frac{1}{4}$ -wave or  $\frac{1}{2}$ -wave plates. But it must be well understood that the path length difference indicated only holds for one certain wavelength and not for others. Thus a plate which is a  $\frac{1}{4}$ -wave plate for the D lines of the spectrum is not a  $\frac{1}{4}$ -wave plate for the F line, for instance.

A mica  $\frac{1}{4}$ -wave plate for the D line has a thickness of about 0.032 mm.

These plates are prepared simply by cleavage. The cleavage, having been started with the blade of a penknife, is continued with a thin piece of Bristol board (a visiting card).<sup>\*</sup> A certain number of plates are cloven and plates to be classed as  $\frac{1}{4}$ -wave or  $\frac{1}{2}$ -wave are chosen in the following manner.

The plate to be examined being placed on the lower platform of the Norrmeberg apparatus without interposition of the converging lens, and the apparatus being set at extinction, a light yellow colour can be seen if the plate is  $\frac{1}{4}$ -wave for yellow rays (D line). The colour becomes indigo if the nicol is turned through  $90^\circ$ .

A  $\frac{1}{2}$ -wave plate gives the same tints if it is placed on the upper platform, because it is only traversed once by the polarised light while a plate placed on the lower platform is traversed twice.

It is as well to rough the work to a micrometer in order to approach the desired thickness, for a  $\frac{3}{4}$ -wave plate which is about 0.1 mm. thick gives effects analogous to those of the  $\frac{1}{4}$ -wave plate.

This method of classifying plates after cleavage is fairly crude; but there are much more precise laboratory methods which allow physicists to make a fresh selection among plates delivered by the optician.

### Diamond

Diamond is the hardest of stones and the most refringent. It is carbon crystallised in the cubic system. Its index of refraction for *D* is 2.43. Its specific gravity lies between 3.5 and 3.6.

When it is transparent and colourless it is the most expensive of precious stones, but there are black diamonds, which are found in larger pieces and which are still harder than transparent diamonds; these diamonds are called "boort". They are much used in industry. For piercing tunnels in hard rocks drills set with boort diamond are used. It is with tools set with a diamond that the grinding wheels used in optical workshops are trued up.

*Sawing.*—Diamond is sawn by the same processes as glass (see p. 35), but the discs are of copper, only 6 to 8 cm. in diameter and some tenths

<sup>\*</sup> A useful "tip" in splitting mica, when very thin pieces are concerned is to perform the operation in mercury light. As the laminae are very parallel a system of bands is seen, and if there is any tendency to deviate from one cleavage plane to another a break in the rings immediately indicates it, and the pressure on the card can be relieved. It is sometimes possible to reunite such false cleavages. (Trans.)

of a millimetre in thickness, turning at about 3800 revolutions per minute. To set them with diamonds they are made to roll on a rotating cylinder of hardened steel covered with diamond dust in grease, while pressing them against it. The pressure of the discs against the cylinder makes the diamond dust penetrate into the discs.

*Cleavage.*—Diamond is cloven, as are other crystals, by the aid of a steel blade which is driven in by a blow while being presented along a line of cleavage. The recognition of the directions of cleavage is a delicate part of the diamond cutter's art. In order that the blade does not slip, its entry must be prepared by tracing a line with the sharp point of a diamond.

The stone to be cut being roughed by sawing or by cleavage, one proceeds to an operation analogous to the smoothing of optical glasses, but, as a diamond can only be surfaced with diamond, two trued diamonds are rubbed one against another by their cloven or sawn faces. Care is taken to collect the diamond powder which results from this work. It is very pure diamond dust (*égrisé*). Diamond cutters call this operation "ebrutage" or "brutage" (grinding). It is done by hand, and for it to be done well the workers must be robust and very experienced.

*Drilling.*—One never has to drill any but very fine holes in diamonds, for example, for making drawplates through which metal wires of a few hundredths of a millimetre diameter are cold-drawn.

A diamond is pierced by percussion and not by drilling. After having commenced the hole with a sharp diamond point the operation is continued with a very fine steel needle on whose point some diamond dust in grease is deposited. The needle is fixed on a little hammer which is lifted up and dropped again at a high frequency by a mechanism.

*Polishing.*—It is the property of crystals that they do not work equally easily in all directions. A facet which requires 1000 turns of the polishing plate to polish it when the stone is presented upon the plate in its optimum direction, will require 10,000 of them if it is rubbed in a bad direction, and the facet may be less plane. Diamond cutters know how to recognise in which direction it is suitable to rub a facet to polish it quickly and well, that is a difficulty of their art. From this it is understandable why the rules for surfacing diamond are so different from those for optical glass. The diamond must not turn while it is polishing. It is set in a low temperature fusible alloy on a support with a rod, called a "dopp". The rod of the dopp is seized in a pincers which is immovable but lets the diamond rest by its own weight and that of the dopp on a flat tool of soft steel on a vertical axis. This flat tool is 30 to 35 cm. in diameter and 4 to 5 cm. thick; it turns at 2000 revolutions per minute.

The flat tool traversed by the axis, which turns between centres, has been adjusted quite normal to it and levelled on it in such a way that the diamond which is pressed on the tool is rigorously immobile during working; that is the condition for obtaining flat facets. If the tool were a little oblique upon the axis the diamond would be subject to small vertical oscillations, which would round off the facets. This danger is avoided in working glass, for the glass carrier, guided by a central ball pin, is at liberty to set itself on the tool whatever may be the variations of inclination of the tool.

The abrasive employed is diamond dust in grease. Polishing diamond dust is collected under a sieve with 10,000 meshes per square centimetre.

### Corundum

Natural corundum is pure crystalline alumina. It is the hardest mineral after diamond. As it crystallises in the rhombohedral system it shows double refraction; its indices of refraction for the D line are about 1.76 and 1.77. In spite of these high refractive indices its dispersion is small. It is often coloured by metallic oxides. When red it is real ruby, also called oriental ruby; when yellow it is oriental emerald; white and limpid, white sapphire; blue, oriental sapphire.

Powdered alumina melted in an oxyhydrogen blow lamp, in a special furnace, may form pear shaped balls of several cubic centimetres volume of a transparent substance which has the chemical properties of corundum and analogous physical properties, for these balls show birefringence and privileged breaking surfaces. If the point of one of these balls is broken the ball breaks up along a diametral plane. Artificial ruby is fused alumina, coloured by the addition of potassium bichromate before fusion.

Corundum and artificial ruby are much used in the precision industries, as little bushings and pivot bearings are made of it for clockwork, for electricity meters, and for all precision apparatus with rotating members.

The roughing of corundum can be done with grit, like the roughing of optical glasses. Emery and carborundum hardly attack it; nevertheless, it can be smoothed on fine carborundum stones. It can be polished with tripoli on paper, felt, or buff (leather).

The methods of sawing, piercing and surfacing for a diamond also apply to corundum (see p. 248), that is to say, that the most suitable abrasive is diamond dust (*égrisé*). Manufacturers, and especially artisans, specialising in the cutting of fine stones, have different methods, but they seem to be of equal value.

Here, for example, is the way in which little pivot bearings are made in corundum.

The lump of artificial corundum is cut into discs with circular saws similar to those described above for sawing diamond. The discs are then cut in squares in such a way as to produce little cubes of corundum. These little cubes are edged round as one does for little optical glasses. With cubes superposed and stuck together, stacks are formed which present numerous projections, for care has been taken to set the cubes with respect to one another so that the edges jut out and are not prolongations of the edges of the neighbouring cubes. The stacks are then pressed on a flat copper plate impregnated with diamond and are made to revolve on their own axis in an opposite direction to that of the rotation of the plate, occasionally turning them round end for end (see p. 54). When all the projections are worn away the stack has become cylindrical, and its section is nearly that of a circle inscribed in the initial cubes.

The cold-hardened copper disc has been set with diamond by driving in a thin coat of diamond dust which has been compressed with another plate of hardened steel either by hammer blows or in a press.

Hollowing the bearing is commenced by drilling a conical hole in each piece of corundum by means of a diamond drill. The conical hole is converted into a spherical cup by the help of a spherical copper tool set with diamond dust by compression in a vice with a hard steel concave tool turned to the radius of the pivot hole to be obtained.

The operation must be repeated several times with tools set with finer and finer diamond dust, commencing with diamond dust passed through a semi-fine sieve (about No. 225).

For polishing one proceeds in the same manner, but using polishing diamond dust (that which has passed a sieve of 10,000 meshes per square centimetre), encrusted on a tool of a softer metal than copper (tin 50 per cent.—lead 35 per cent.—antimony 15 per cent.).

Certain lapidaries make use of an apparatus which appears to be recommendable for surfacing small lenses of very deep curvature (see p. 79). The tool (convex), instead of being screwed on the rotating axle, is mounted on the extremity of that axle by a sort of cardan joint which leaves the axis of the tool free to tilt in any direction for a few degrees. The corundum cup to be worked is pressed on the convex tool and, while still pressing, the workman gives the piece a transverse oscillatory movement by displacing the piece to be surfaced almost parallel with itself. Thanks to the cardan suspension only the force along the axis of the tool encounters any resistance. The transverse forces which, on an ordinary optician's lathe, would deform the surface by "scouring" are without effect here.

## CHAPTER VIII

### CENTRING, EDGING, AND CEMENTING LENSES

#### CENTRING SPHERICAL SURFACES

When a lens has been surfaced it still has to be centred and edged. Imperfect centring can compromise the best qualities of the lens, as is easily understood. Let us consider, for example, an anastigmatic objective whose focus is at  $F$  (Fig. 107). This objective, composed of five lenses, has been calculated on the supposition that the five lenses are perfectly centred, that is to say, have their optical axes exactly superimposed. Three rays leaving  $A$ ,  $B$  and  $C$  converge to the focus. Let us suppose that the biconvex glass is decentred, as indicated on

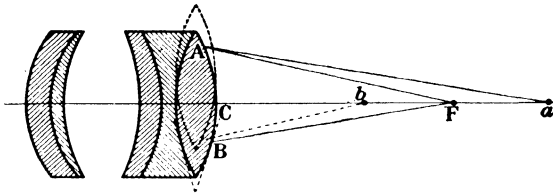

FIG. 107.

the figure by a dotted line. If planes tangent to this lens at the points of entry and departure of the rays are drawn, these planes form virtual prisms which have the same effect on the rays as the lens. The nearer the tangent planes are to the edges the greater is the angle made between them; near the centre of the lens, on the contrary, they are almost parallel. In the decentred lens the ray passing through the point  $A$  traverses a virtual prism which is too closed (has too small an angle); it is, then, insufficiently refracted and goes to meet at  $a$  the ray  $CF$  which, itself, is but little influenced by the decentring. Conversely the ray which leaves at  $B$  traverses a virtual prism which is too open (too obtuse), hence it is refracted too much and cuts the ray  $CF$  at  $b$ . Thus the fault of centring of the biconvex lens alone, produces a longitudinal aberration  $ab$ , which may be much larger than those which would have been found inadmissible in calculating the radii of curvature.

This reasoning shows that a defect of centring of 0.5 mm. which would be tolerable on a doublet objective of large diameter, would become quite intolerable on a small objective, for the stronger the

curvatures are, the more a small displacement of the tangent planes, which form the virtual prisms referred to above, changes the angle of those prisms. The greater the number of component lenses in an objective the more precise the centring must be, for the errors of centring of the different lenses can be cumulative.

When one arrives at the dimensions of microscope lenses centring to within a few microns is necessary. The centring is done partly in the mounting, by the turners, and partly on the lenses, by the opticians.

The turners, after having exactly centred the mountings of the lenses on the lathe, form lodgements in them which are very concentric with the mountings; they give these the exact diameters of the lenses, plus a very small tolerance, and for this purpose make use of plug gauges. The opticians, after having carefully centred their lenses on the edging lathe, edge them to ring gauges corresponding to the plug gauges. If a plug just enters the lodgement of a lens and if the lens just enters the corresponding ring one is assured that the lens will enter its lodgement practically without play, *i.e.* with a tolerance of 2 or 3 hundreds of a millimetre; the small error of edging could be added to the error of centring of the lens alone.

If it is desired to push the precision further (and that is necessary for microscope objectives) the lenses must be seated and the centring corrected by forcing the metal back a little more on the appropriate side.

### Centring with a Light

The centring tube is mounted on the axle of the centring machine. It is a brass tube, which finishes in a sharp edge against which the lens to be centred should be placed. In order that the support shall not be too oblique, one chooses centring tubes with an exterior bevel for receiving convex surfaces or with an interior bevel for concave surfaces. The tube should be perfectly centred on the axle of the lathe (this is assured at each mounting) and the sharp edge must be, by construction, in a plane rigorously normal to the axis of the lathe. To verify this, a plane parallel glass plate is pressed against the sharp edge. The glass being fixed to the tube, and the machine turning, the image of objects or lights seen by reflection in the glass should appear to be absolutely immobile. Any error of adjustment of the tube will have its repercussions on the centring of the lenses.

When a lens is applied to the cut end of the tube the centre of the surface in contact with it is on the axis of the lathe if, as has been verified, the cut edge is in a plane normal to and exactly centred with that axis. The centring of the lens consists in also placing the centre of the exterior surface on that axis, which then will define the optical axis of the lens. When the centre of the exterior surface is exactly

on the axis of the lathe the surface seems absolutely motionless, even when the machine is in motion. But if the centre of the exterior surface is off the axis, the surface swings when the machine turns and, with it, all the images which it forms by reflection are displaced. To centre the lens it is made to slide on the circular cut edge of the centring tube until the reflected images are motionless. In order that this sliding may be effected the cement with which the lens is stuck to the tube must have a certain plasticity; for this purpose a heat softening cement is used and the centring tube is heated to keep the cement soft. The cement can be a mixture of pitch and sealing wax (a little less wax than for mallet cement), or a mixture of about  $\frac{2}{3}$  rosin and  $\frac{1}{3}$  of yellow wax or filtered black pitch. The cement being deposited in the form of a ledge on the cut edge of the centring tube it is squashed with the lens until, through the lens, all the cut edge is seen quite bare of cement. The axis is turned and the image of a lamp or distant object reflected in the exterior surface is watched. One presses on the more appropriate edge to render the image motionless and repeats this operation until the image is perfectly immobile.

The circle described by the luminous image being almost perpendicular to the axis of the lens, the eye must be placed in the neighbourhood of that axis to see it properly. The light source must also be in the same direction, but sufficiently to one side of it not to be masked by the observer's head.

To understand the best dispositions for observation, it is necessary to refer to the theory of spherical mirrors. If the light source  $L$  (Fig. 109) is distant, a convex reflecting face gives an image  $I$  situated between the centre of the ray passing through  $L$  and the surface of the mirror. A concave mirror gives an image situated between the middle of the ray passing through  $L$  and the centre of curvature, if  $L$  is beyond that centre. But, if the curvature is very slight the centre may be placed beyond the lamp  $L$ ; in this case the lamp comes between the centre of curvature and the middle of the ray and hence its image is thrown far behind. If the lamp were still closer to the surface, its image would be on the other side of the mirror, somewhere between infinity and the mirror surface.

It is seen from this that it is not always convenient to centre with a light by using the image reflected from a slightly curved surface. When it is possible to stick either face to the tube, the face which gives an image  $I$  at the best distance for observation (*i.e.* very close to the observer) is left free.

If it is desired to centre to a high precision it is absolutely necessary to make use of a cross line viewing telescope which can be focussed on the image (Fig. 108). The viewer can be as much more powerful as the image is closer. For centring microscope lenses, images which are

generally at the most a few millimetres behind the exterior surfaces are observed. In this case a very powerful viewer must be employed (enlarging 50 times, for example). The viewer, carried on a massive base, is placed on the machine in the prolongation of its axis. It can be fitted with knobs for setting its focus and direction.

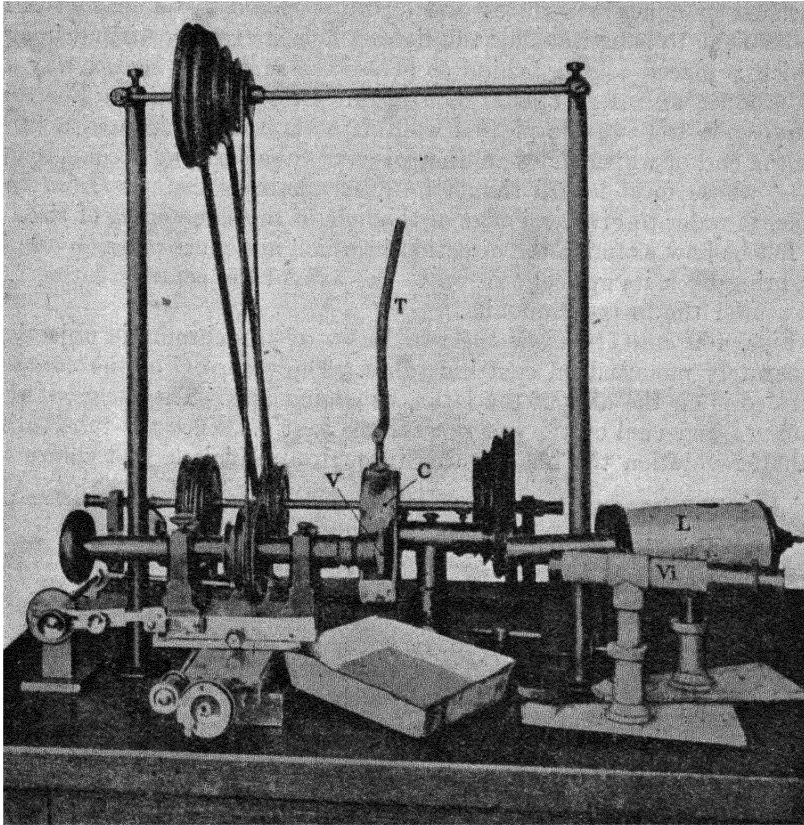

FIG. 108. Machine for centring with a light and for edging.

It is convenient to employ autocollimating viewers, *e.g.* viewers carrying in themselves a point light source whose image, reflected by the lens to be centred, is viewed (Fig. 87). When use is made of autocollimating viewers they must be set on the centre of curvature of the exterior face, and it is this centre whose circular displacement is observed when the machine turns. Finally, when use is made of a centring lathe with a horizontal axis it is convenient to use viewers bent to a

right angle (autocollimating or not) so as to set them while looking downwards.

A small and quite round light source must be used with the viewer. A lantern with a metal wall in which a hole about 1 mm. in diameter has been pierced is used. It is this little hole which most often forms the source  $L$  referred to in the text. Nevertheless, when slightly-curved surfaces or concave surfaces of long radius have to be centred it is convenient to substitute for the lighted hole its real or virtual image which is placed a little behind or before the surface in such a way as to produce an image  $I$  at a good distance for observation. For this purpose, in front of the pierced wall of the lamphouse is fixed a tube on the end of which slides another piece of tube carrying a convergent lens, whose focal length should be nearly half its distance from the hole, in order to give an image of the hole of the same order of size.

Let us now examine the direction in which one must press on a lens to bring back its optical axis on to the axis of the centring lathe, *i.e.* to render the image immobile.

Figs. 109 and 110 show the two lenses of an achromatic objective separately mounted on centring tubes. The centre  $C$  of the contact surface is on the axis of the lathe, or edging axis. The image of the source  $L$  reflected on the exterior surface is at  $I$ . When the tube turns a half-revolution the image turns through a semicircle and comes to

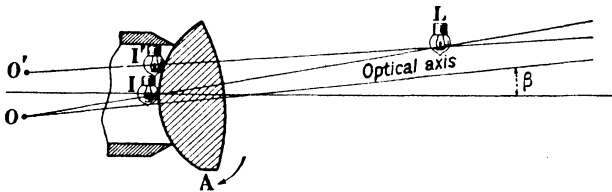

FIG. 109.

$I'$ . For both lenses the optical axis is inclined in the same direction in both figures; it makes an angle  $\alpha$  with the edging axis of the divergent lens and an angle  $\beta$  with that of the convergent lens. For both lenses it would be necessary to press at  $A$  on the lower edge of the lens to make the lens slide in such a way as to bring the optical axis back on to the edging axis.

How is the point  $A$  to be found? When the lathe turns, the movement of the image  $I$  indicates it. If the centre of the circle described by the image  $I$  is estimated, the radius which goes from that centre to the image is parallel to the radius which goes from the centre of the lens to the point  $A$ .

Both radii are in the same direction when the reflecting surface is

convex. It can easily be seen that they are in contrary senses when the reflecting surface is concave.

When two lenses have to be joined together, a mark is made on the circumference of each of them at *A* on the side where it would be necessary to press for correcting the residual error, and on the other side of the first lens a mark *B*, symmetrical with *A* is made. When these lenses are mounted care is taken to place the mark *A* of the second lens opposite the mark *B* of the first lens, for the reason indicated later on concerning the centring of two combined lenses.

The errors  $\alpha$  and  $\beta$  are of the same order of size. They measure closely the smallest amounts of sliding which the workman is capable of impressing on the lens for centring it.

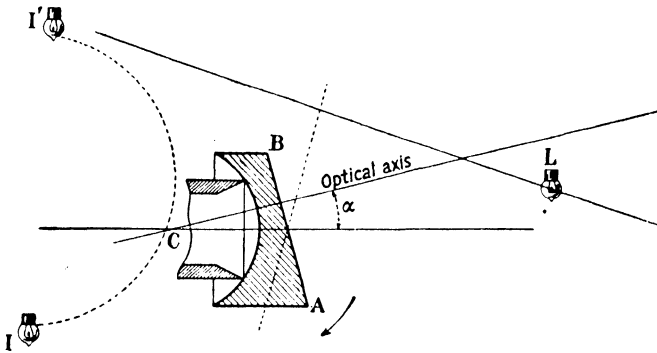

FIG. 110.

How ought these lenses to be fitted separately on the centring lathe? Either one or the other of their faces could be applied to the centring tube and which it should be is not a matter of indifference.

When two lenses are united their optical axes may be superposed with all possible precision, but the most important condition to be realised is to place the optical centre of one lens as close as possible to the optical axis of the other lens. Indeed, if this is so, two rays leaving the first lens in positions symmetrical with respect to its axis (Fig. 107) encounter the second lens at equal distances from its optical centre and, if the optical axis of the second lens is slightly inclined to the axis of the first, the above mentioned symmetrical rays, still traversing the same thickness of lens, are not noticeably deviated by this small inclination. If, on the contrary, the optical centre of the second lens were a little off the optical axis of the first, one of the above mentioned rays, encountering the second lens nearer to its edge than the other ray would be more deviated than that one and an aberration would be introduced.

When two lenses are brought together, joined or not, their axes can occupy one of the following three relative positions, all of which are defective:

1st. The optical axes are parallel to one another, at a little distance one from the other.

2nd. The axes are in one plane, but form a little angle between them.

3rd. The axes are not in the same plane.

The first case cannot occur if the two lenses are joined by a common curvature, since the common centre of the surfaces in contact is the intersection of the optical axes. The third case partakes of the preceding two. There remains, then, the second case. For a given angular deviation of the two optical axes, the optical centre of one of the lenses is as much nearer to the optical axis of the other lens as the radius of the contact surfaces is shorter. It is, moreover, interesting to place the centre of curvature common to the two lenses upon the edging axis. From this we have the following rule.

*For centring and edging the two lenses of an objective with two joined glasses having the same common curvature, it is expedient to centre and edge each of these lenses with the interior surfaces of the combination secured to the centring tube.*

This rule is generally disregarded by makers who are dominated by the desire to offer only lenses whose edging is perfect in appearance, *i.e.* without the slightest chip on the circular edges which limit the cylindrical circumference, for under the mill (or stone) there is a risk of the edge of the glass chipping. When a meniscus is edged it is the edge of the concave surface which is most exposed to chipping, because this edge is less supported by the body of the glass, than is that of the other surface. If an unsymmetrical biconvex lens is concerned there is more risk of chipping the edge of the less curved surface. To guard against this accident one very often employs centring tubes having almost exactly (to 0.1 or 0.2 mm.) the diameter which the lens to be edged must have. The face stuck to the tube, thus being well supported by it, is less apt to chip. It is to avoid chips to an even greater extent that, contrary to the rule enunciated above, one generally sticks the crown of an objective on to the centring tube by its less curved surface whose edge is the more fragile, in order that that edge shall be well shouldered by the tube.

### Centring Two Cemented Lenses

How should one part of a cemented lens be orientated in relation to the other? Let us take a tracing of Fig. 109 and place it on Fig. 110 in such a way as to juxtapose the surfaces to be cemented as well as the axes of edging. This juxtaposition can be realised in two ways, according to whether the tracing is right side or reverse side up, *i.e.*

according to whether the mark *A* on the flint lens or the mark *B* is placed opposite the mark *A* on the crown lens. In the first case it may be observed that the optical axes of the two lenses make between them an angle of  $(\alpha + \beta)$ ; in the second case they make an angle of  $(\alpha - \beta)$  (Fig. 111), which is almost always negligible, since the workman has to reduce each of the angles  $\alpha$  and  $\beta$  as far as possible. If these small residual errors were equal, the centring of the two lenses would be perfect, even though the optical axis did not exactly coincide with the axis of the mount, for it does not greatly matter if the optical axis of the objective does not exactly coincide with the geometrical axis of the telescope. It is, then, the marks *A* and *B* which should be put one beside the other.

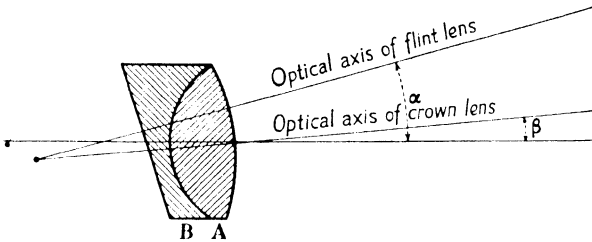

FIG. 111.

The smallest extent to which a workman can slide a glass is some tenths of a millimetre. When microscope lenses are concerned, a few tenths of a millimetre are equivalent to an appreciable angle and the difference  $(\alpha - \beta)$  may no longer be negligible; one should endeavour to correct the residual error  $(\alpha - \beta)$  by sliding the crown on the flint. If it is wished to keep this possibility in reserve the crown should be edged to a slightly smaller diameter than the flint so that the crown, thus displaced, does not prevent the objective from entering its mount.

Thus, thanks to the compensation of the residual errors, the centring of a compound lens can be realised with greater precision than that of the individual component glasses, the latter having only a mechanical and not an optical precision.

### EDGING

Centring being finished, the centring tube is left to cool for a time in order to harden the cement, and then edging is proceeded with.

Edging is an operation which only calls for mechanical precision and not optical precision. It concerns bringing a lens to a desired diameter, which should be equal to the interior diameter of the mounting for the optical part, within a few hundredths of a millimetre on the minus side.

Good centring and edging machines are adaptations to optical work of the grinding machines of precision mechanical workshops. These machines embody a perfectly round, fine grain grinding wheel, turning very rapidly between journal bearings free from play, and a lens-carrying arbor turning slowly in bearings equally free from play. Mountings between centres are more precise than mountings in bearings.

The majority of edging machines are made in the following fashion

The axis of the grinding wheel is generally parallel to the lens bearing mandrel. This arrangement allows of easily wetting the grinding wheel in the usual way. It has the drawback of only allowing a small thickness of glass to be removed at a time.

A micrometer screw allows the grinding wheel to be given the advance desired, with much precision. The centring tube which has been spoken of in the previous section is mounted on the arbor of this machine.

Edging machines in which the axis of the grinding wheel is perpendicular to the axis of the lens carrying mandrel allow a much greater thickness of glass to be removed in a single pass; for the following reason. In the first case the lens-cylinder and the grinding wheel cylinder enter into contact by a generatrice of the glass or of the grinding wheel. In the second case the two cylinders only make initial contact at a point. A small advance of the tool provokes a great resistance in the first case and a very much smaller resistance in the second case. If, then, after a first attempt the positions of the crossed axes of the grinding wheel and the glass have been fixed by successively advancing the tool and as soon as the distance from the grinding wheel to the axis of the glass has been marked, giving edging to the desired diameter, one can obtain, in one or two passes, the edging to the same diameter of all the other lenses centred successively on the same mandrel. The arrangement of crossed axes is principally of interest for the edging in series of numerous lenses to the same diameter.

There are still in existence some lever edging machines. An iron lever, charged with emery slime, rubs on the circumference of the lens by hand pressure. The streaks which form on the glass are removed afterwards by rubbing with a trough of sheet iron or zinc, also charged with emery slime. The use of these tools, which may be qualified as barbarous, should be reserved for the edging of eyepiece lenses or magnifiers to the exclusion of precision objectives.

### **Centring and Edging Smoothed Lenses**

Centring with a light is usually carried out on polished lenses, but one sometimes needs to execute it on smoothed lenses. When small lenses mounted on a vertical centring lathe are concerned, it suffices

\* See also pp. 69-75 of *Prism and Lens Making* (F. Twyman). (Trans.)

to place the lens—after the final smoothing—on an edging machine whose lens carrier has a vertical axis and to wet the glass lightly. If the lens is made to turn quickly enough the water spreads itself over it in an infinitely thin layer whose thickness is regularised by the centrifugal force. That layer of liquid renders the surface reflecting enough to permit of centring with a light.

Here are two examples to show the value of edging after smoothing.

Some small lenses have been trued in a block containing a large number on the same tool. They are of an appreciably larger diameter than the quoted diameter of the finished lens. It can happen that after having reduced them to the final size a new row of lenses can be put on the block. There is then an appreciable economy of time in edging before polishing.

Some very deeply curved lenses can only be trued one by one. If they are edged after the final smoothing it may be found that three can be blocked together without overlapping the concave tool. The economy of time is still more considerable than in the preceding example.

### Centring and Edging Spectacle Lenses

The centring of spectacle lenses does not call for great precision, especially when lenses of low power are concerned. The tolerance of centring is about 1 mm.

The centre is determined by the prismatic effect. With the lens placed 30 or 50 cm. from the eye, one observes a vertical or horizontal line which overlaps the edges of the glass. If the image of the line in the lens prolongs the line itself the image passes through the centre of the lens. By successively observing on two lines perpendicular to one another one can, then, mark the centre of the lens. The reason for this is that only the rays which pass through the centre of the lens are undeviated, all others suffer the prismatic effect to a greater or less extent.

There are small instruments in existence which allow the centre to be set with the desired precision and marked with a little spot of ink.

The centre being marked it is easy to centre the lens on the axis of the edging machine.

Spectacle lens edging machines are grinding wheel machines, of the type of copying machines, which allow of edging round, oval or any other form whatever of which a model has been made. One first edges cylindrically to bring the glass to the right size and shape, then, except for the lenses of rimless pince-nez, an edge or a channel must be ground round the circumference to suit the mounting, *i.e.* the circumference must be given a V-shaped profile with either a projecting or an entrant angle. In the first case the lenses are said to be chamfered (*chanfreinés*); in the second they are grooved.

The shaping of grooving wheels is not difficult, but it must be repeated frequently for the edge of the wheel, being the part that does the most work, wears away very quickly.

In the case of chamfering wheels it is, on the contrary, the bottom of the groove on the wheel that does the least work, but which is the most difficult to shape to a sharp angle. That is why these wheels are generally composed of two bevelled wheels stuck to one another by their smaller bases.

#### **VERIFICATION OF THE POSITION OF THE AXES AND CENTRING OF CYLINDRICAL SURFACES**

To centre a cylindrical surface is to bring the centre of curvature of the medial section of the surface on to the axis of the centring machine, representing the axis of the future lens mount, which must be perpendicular to the axis of the surface.

Hence, before commencing centring it is necessary to make sure (except for sphero-cylindrical lenses) that the axis of the cylindrical surface is parallel to the plane surface (plano-cylindrical lenses) or that the axes of the cylindrical surfaces (bi-cylindrical lenses) are parallel to each other. The defects of parallelism of the axes can be of two sorts. The axes although in one plane parallel to the axis of the machine can form between them a small angle; the glass, in this case, behaves in the manner of a prism, it is said to produce a prismatic effect. Otherwise the axes of the surfaces projected on a plane normal to the axis of the machine can give non-parallel projections; it is then said that the axes are crossed, and this defect modifies the focal length of the glass.

If the conditions of parallelism are not fulfilled the defect results from defective blocking or malleting before surfacing the second surface. In this case the surfacing of one of the surfaces must be recommenced.

Thus, before proceeding to centring, it is necessary to make sure that the axes are well placed with respect to one another.

#### **Dioptric Verification (by refraction)**

A viewer is pointed to a small lighted hole situated, for example, in a horizontal direction, then the cylindrical lens to be examined is interposed in the line of vision, placing it in such a way that its axis is almost vertical. Putting one's eye to the viewer it is observed that the image of the hole is transformed into a band which is horizontal, or, more exactly, is perpendicular to the axis of the cylinder, and whose height is equal to the diameter of the image of the hole before the interposition of the cylindrical lens. If the cylindrical lens is thicker

at the top than at the bottom a prismatic effect is produced which displaces the band vertically in relation to the horizontal thread of the cross lines in the viewer. If the band is bisected by the horizontal thread the axis of the cylindrical surface is parallel to the plane surface (plano cylindrical lens), or else the projections of the axes of both surfaces on the vertical plane of viewing are parallel. If these projections make a small angle  $\alpha$  between them, the prismatic deviation is  $\alpha (n - 1)$ , *i.e.* it is sensibly equal to  $\alpha/2$ .

Double the precision is obtained if, instead of comparing the direct aim to the aim through the cylindrical lens, the latter is compared to another aim through the same lens which has been turned through  $180^\circ$  around the line of sight. In this case, one measures a deviation sensibly equal to  $\alpha$ .

A bi-cylindrical lens can be considered as composed of two plano-cylindrical lenses stuck to one another by their plane surfaces. We have just seen that, if a plano-cylindrical lens is interposed before the viewer, the image of the luminous hole is transformed into a band perpendicular to the axis of the cylindrical surface. If, further, a second plano-cylindrical lens is interposed that produces a similar effect, *i.e.* it would give, by itself, a band perpendicular to its axis. The image produced by the interposition of two plano-cylindrical lenses or of a bi-cylindrical lens is only a sharp band centred on the cross lines when the axes of the two cylindrical surfaces are parallel one to the other. If they are not, the position of the band may be changed by the prismatic effect and that effect is very sensitive. It can also produce the "crossed axes" effect referred to above but this effect, which renders the image diffuse, is much less sensitive than the prismatic effect.

Dioptric verification is rapid and sufficiently precise in many cases. If a greater precision for observing crossed axes is sought, recourse can be had to verification by reflection.

### Catoptric Verification (by reflection)

The luminous hole and the viewer are placed closely side by side on a table and at the same height. The glass to be examined is placed at the same height and in front of the viewer in such a way as to give reflected images of the hole in the viewer. Several lengthened images appear which cannot be simultaneously focussed. There are images reflected by the anterior surface and images reflected by the posterior surface but refracted in the thickness of the glass. To fix our ideas it is supposed, in the following, that the axis of the cylinder is horizontal.

Each surface gives an astigmatic image of the lighted hole, *i.e.* there are two focussing positions for that image. The first position corresponds to focussing upon the image which would be given by a plane tangential to the cylinder. The observed image is lengthened in a

direction normal to the axis, that is vertically, since this fictitious plane could be rolled on the cylinder from below to above. It has the form of a parallel, sharp sided band having the width of the image which a tangent plane would give. The second position corresponds to focussing on the image which would be given by a sphere inscribed in the cylinder. The observed image is lengthened in the direction of the axis, *i.e.* horizontally, since the imaginary sphere could roll from left to right inside the cylinder.

Instead of focussing by displacing the viewer or modifying the extent to which it is drawn out, one can just as well leave the viewer untouched and move the lighted hole nearer to or further from the glass to be examined. It is this latter method which must be adopted in order to refer to the fixed position of a thread of a reticule. Indeed, when one has focussed on a vertical band image reflected by the front surface while making one of its edges coincide with one of the cross lines, one can, by displacing the lighted hole, bring the band-image reflected by the anterior surface to be in focus and to cut the cross lines again.

If one edge of this band-image can be superposed on the cross line the axes of the two surfaces are not crossed. If the band-image makes a small angle with the cross line this angle measures the defect of parallelism of the projections of the axes on a plane normal to the viewing plane. As the band-images are long this way of appreciating the defect is very sensitive.

The centring lathe can be made use of as a support for this test, but it is not obligatory since it is not necessary to turn the lens under examination. The method of turning over always has, even in this case, the advantage of doubling the precision.

The orientation of the lens can be what you will, but according to whether the viewing beam falls far from the axes of the cylinders or is almost in their plane, the image is deviated more or less. It is, then, as well to make the lens to roll a little on itself, until the effect of this rolling becomes but slightly appreciable.

### Centring

Centring of plano-cylindrical and sphero-cylindrical lenses with a light is carried out, on the centring tubes which serve to support spherical lenses, on a centring machine. Special supports are necessary for bi-cylindrical glasses.

*Plano-cylindrical glasses.*—The centring tube, being corrected as for the centring of spherical lenses, the plane side of the lens is stuck to the edge of the tube with its axis disposed horizontally.

First of all the medial section must be made to pass through the axis of the tube.

Having set the viewer on one of the edges of the lens, normal to the axis (if the lens is rectangular), one turns the centring tube through  $180^\circ$ ; the viewer should then be found to be set on the other edge. If the lens is round the setting is made on two little points previously marked at the extremities of the diameter parallel to the axis. The lens thus being centred in one way the centre of curvature of its medial section must be set on the axis of the tube. For this purpose the viewer is directed towards the middle of the lens and focussed on the horizontal band-image; then the tube is turned through  $180^\circ$  and the band-image should appear at the same place. When this is so, the lens is centred in the second way.

There is no special precaution to be taken to turn the tube exactly through  $180^\circ$ . When, having set one of the threads of the cross-web to separate the luminous band into two equal parts throughout its length (or to coincide with one of its edges), the centring tube is rotated, the image is seen to describe a trajectory, while turning about its centre, like a stick which is thrown in the air. When, in its displacement, the luminous band again becomes parallel to the thread of the reticule, the tube has described a rotation of exactly  $180^\circ$ . It is, then, completely needless to put reference marks on the tube or the glass in order to execute an exact half-turn.

When, after rotation through  $180^\circ$ , a defect of centring is observed the lens must be made to slide on the tube in such a way as to correct half the error. It is as well to repeat the operation several times, for in displacing the lens in a vertical direction the adjustment in the horizontal direction may be altered and vice versa.

*Sphero-cylindrical Lenses.*—The lens is stuck on the tube by its spherical surface, the cylinder axis being horizontal. The adjustment is again made in two successive operations. The vertical band-image having been focussed, the vertical cross line is set in coincidence with one of the edges of the band. The tube is turned through  $180^\circ$  and if the image does not return to the same place the lens is made to slide on the tube until the coincidence is perfect, the axis of the cylinder remaining horizontal.

When this result is obtained the horizontal band-image is focussed and the lens is turned about the axis of the cylinder until a  $180^\circ$  rotation of the centring tube brings the band-image back exactly into coincidence with the horizontal cross web.

Finally, it is verified that the second operation of the adjustment has not altered the result of the first.

*Bi-cylindrical Lenses.*—Fig. 112 shows an adjustable support for centring bi-cylindrical lenses. The two walls, which terminate in edges upon which the lenses should bear, are supported by a platform integral with a cylindrical stem, which is to be mounted on the end of

the arbor of the centring machine. A saw-cut which is made to yawn by an adjusting screw with a conical head allows the inclination of the platform to be varied a little in one direction in relation to the axis of the machine; a second saw-cut with conically headed adjusting screw allows the inclination to be varied in the normal direction. Clamping screws, which are not shown, assure the stability of this adjustment.

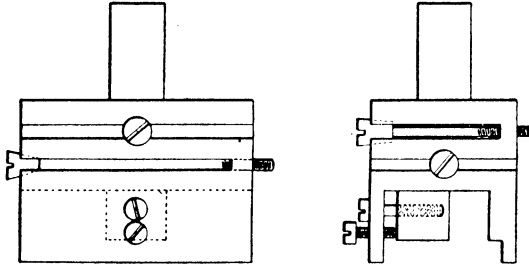

FIG. 112.

One of the walls is furnished with a pushing screw and a pulling screw for adjusting the symmetry of the two walls with respect to the axis of the lathe.

To adjust the support the exterior plane of the walls must first be rendered exactly perpendicular to the axis of the lathe.

For this purpose, press a plane glass with parallel faces on the walls. Look at the image of the lighted hole and turn the axis of the lathe through  $180^\circ$ . The image seen usually describes a semicircle which is reduced to a point by moving the conical headed adjusting screws.

Although situated in a plane normal to the axes, the edges of the walls might not be exactly parallel to one another; this parallelism should be obtained by construction with the greatest possible precision, but if it is not very exactly so the axis of the cylinder pressed on the walls is tilted a little. This can be observed on giving the axis a half turn, which displaces the band-image as if it slid parallel to itself on the walls. One of the conical headed screws can correct this defect.

The second operation in the adjustment of the support consists in working the adjusting screws of the walls in such a way that the edges upon which the lens to be centred must rest are quite symmetrical with respect to the axis of the lathe. To execute this adjustment set the viewer on the middle of one of the edges and turn the axis of the lathe through  $180^\circ$ . If the viewer is not found to be set on the second edge, which should be symmetrical with the first, operate one of the adjusting screws of the walls.

The walled support being adjusted, the perfect centring of a lens is readily obtained as follows.

The axes of the lenses being horizontal, the viewer is pointed on one of the vertical edges of the lens (rectangular lenses) and the support is turned through  $180^\circ$ . The viewer should be found to be pointed exactly on the other vertical edge. If the lens is round the extremities of a diameter parallel to the axis are viewed. Thereafter the horizontal band-image reflected by the anterior surface is focussed (this image is not effaced when the posterior surface is wetted). The support is turned through  $180^\circ$ , and the aim of the viewer should not change. If it does change the glass is made to slide on the support and the double verification recommenced by aiming first on the edges and then on the horizontal band-image.

### CONSIDERATIONS ON THE CEMENTING OF LENSES

Every time a pencil of light traverses a surface of a lens (or of a prism) a small part of it is lost by reflection at the surface traversed. The loss is higher as the refractive index gets higher. When two lenses are coupled, without being cemented one to the other, there are four penetrations of surfaces from air into glass or from glass into air. At each normal penetration of a lens the loss by reflection is about 4 per cent. to 5 per cent. of the incident light, it is greater for oblique penetrations. If for the air in which a lens is immersed a liquid is substituted—a cement or a transparent varnish—the index is no longer the index of the glass relative to air (*i.e.* the absolute index which is found in catalogues of glasses), but the index of the glass with respect to the liquid, the cement, or the varnish. This relative index is the ratio of the absolute indices of the two media. Thus, if a crown glass of index  $n_D = 1.53$  is plunged in water ( $n_D = 1.33$ ), the index of the crown in relation to the water is  $\frac{1.53}{1.33} = 1.15$ . The loss by reflection of the light traversing the glass surface in the water is then much smaller than the loss suffered by the same pencil traversing the glass surface in the air. The loss by reflection would even be nil if the water were replaced by a liquid having exactly the same index as the crown glass. In this case the relative index would be  $n_D = 1.00$  and the crown glass plunged into the liquid would become invisible (if the liquid were colourless\*).

If a layer of some thickness of a cement of too high or too low an index were interposed between two lenses, the equivalent of an uncalculated three lens combination would be realised instead of the calculated two lens combination and the optical qualities of the combination would be mediocre.

\* Or, what is more to the point, if the glass were colourless. (Trans.)

It is in order to avoid losses by reflection that it is worth while cementing lenses with a cement having an index very close to those of the lenses to be put together.

The choice of such a cement has also an economic advantage. Since a glass plunged in a colourless liquid of exactly the same refractive index becomes invisible, there is no need to polish the face to be cemented or even to smooth it precisely. In fact, if one cements the two completely polished glasses of one objective with Canada balsam and also the two glasses of a similar objective but of which the crown has not been polished, a person, even if forewarned, would find it difficult to see a small difference between the two objectives. Thus, when a cement of the same refractive index as the crown is used one can be very tolerant of the quality of the surface of the crown. It is sufficient to care for the surfacing of the flint surface to be cemented; the cement prolongs (so to speak) the crown up to the surface of the flint which will be the surface of separation of the two media of different refractive indices.

The same considerations indicate that the tolerances of surfacing should be more severe for the exterior surfaces than for the cemented surfaces, for the relative refractive index of the flint with respect to the crown is always nearly enough unity. Precision is expensive, it must only be demanded to the extent to which it is indispensable.

As the cement prevents loss of light by reflection, this advantage should not be compromised by an equivalent loss of light by absorption. The layer of cement must, then, be very thin, and the cement chosen must be as colourless and transparent as possible.

These conditions of refractive index and of transparency limit the choice of cements. Lenses have been cemented with turpentine and also with castor oil, simply heat sterilised, but the refractive indices of these substances (about 1.47) are a little low.

*Castor oil*, more fluid than warm balsam, allows larger surfaces to be united, but it does not cement them (in the true sense); it serves to prevent losses of light by reflection at the surfaces in contact.

When optical parts, which should transmit ultra-violet radiations (quartz-fluorite lenses, for example), are concerned, the two elements are united by a thin layer of *glycerine*. This liquid does not stop ultra-violet radiations, and practically suppresses the losses of light by reflection at the two surfaces in contact.

The cement most used in the last century has been *Canada balsam*; it is still much used to-day. Its refractive index ( $n_D = 1.52$  to  $1.53$ ) is the mean index of crowns, of white spectacle glasses and of plate glass, but Canada balsam is yellowish, especially if it has been heated too much.

For some years *Gum Dammar*, which is more colourless than Canada

balsam, has been used. It has about the same refractive index and is not so expensive.

The operations of cementing with Canada balsam and with Gum Dammar are described in detail below.

### Preparation of Lenses

In order that the cement squeezed between the two lenses shall be able to spread easily without being compressed too much the lenses must touch in their centres, giving two or three rings for lenses of about thirty millimetres diameter and a greater number for larger lenses.

This difference of curvature is specially necessary when two large lenses are to be cemented to one another, for it is more difficult to expel the excess of cement which there is between them. As a result of this difference in curvature the thickness of cement near the edges of large lenses ceases to be negligible. For this reason glasses of more than 60 to 100 mm. diameter are not usually cemented.

When lenses must be placed together without being cemented, but with faces of the same curvature in contact, the flint is given a deeper curvature, by some rings, in order that the lenses, touching one another by their circumferences, may more easily be exactly centred.

Before cementing, the lenses must be bathed in petrol, wiped with a very clean cloth to degrease them, and finally rinsed in 90° alcohol or ether.

Glasses which have been individually centred with care should bear, on their circumference, a little mark serving as a reference mark, as was explained in the section dealing with centring.

For ordinary objectives one contents oneself with cementing the glasses by observing that the marks placed on their edges are set opposite one another and that they are centred on one another by exactly superimposing their edges.

When an extremely precise centring is desired, cementing on a centring lathe can be proceeded with. The centring of the crown is first executed as indicated above, and a mark is placed to indicate the direction of the residual error, if necessary, as explained above. The crown is edged to a slightly smaller diameter than that of the flint. The flint is then fixed on the centring lathe and remains there for cementing. It is first centred separately with all possible care and then edged. Now the cement is interposed between the two lenses and the crown can be centred upon the flint exactly as it has been centred alone on the lathe, but instead of sliding it on the centring tube, it is made to slide on the flint and can even be made to roll a little since the convex curvature is very slightly deeper than the concave curva-

ture. As care has been taken to set the marks on the edges opposite one another the sliding to be effected is very slight.

### Preparation of Canada Balsam

It is generally to be expected that cemented lenses can be, in service, exposed to summer sun, *i.e.* taken to a temperature of about  $50^{\circ}$  C.; they must not, then, become uncemented at that temperature. For this the balsam is sufficiently cooked not to run at  $50^{\circ}$ .

For use it must be brought to a liquid or pasty state. When small glasses are to be cemented or pieces which it is desired to use directly after cementing (blocks or protectors for working prisms, for example) a well cooked balsam, of light yellow appearance not becoming tacky at less than  $25^{\circ}$  C. and slightly brittle to the finger nail, is used. For cementing large lenses which should remain long in the oven (see later), one uses a balsam of the consistency of a soft caramel; the balsam finishes cooking during stoving. The time of stoving, *with an extremely low heat*, varies from 10 hours to 48 hours, according to the initial state of the balsam and the consistency which it is wished to obtain. The balsam is poured into a porcelain cupel (cup), which is placed on a bed of sand in a vessel placed on the stove. It should hardly steam. If the fire were too hot the balsam would brown; it is best to cook it in a drying cupboard kept at a temperature of  $40^{\circ}$  to  $50^{\circ}$  C. If this temperature is not exceeded the balsam hardens without becoming coloured. There are, in laboratories, vacuum drying ovens, whose temperature can be regulated, in which drying is more rapid.

### Cementing

Warm the glasses in an oven to about  $60^{\circ}$  C. Make a small quantity of balsam lukewarm in order to melt it.

Sweep the surfaces to be cemented with a camel hair brush, in order to remove dust—do not touch them with the fingers. Deposit a drop of balsam in the middle of the flint; squeeze it with the crown in such a way that the cement escapes equally all round the glasses. Press fairly heavily so that the lenses almost touch one another in the centre. Centre them carefully upon one another by their circumferences, with the reference marks one in front of the other. If one has an expanding centring mandrel it can be used for centring the crown on the flint by placing the still warm lenses upon the centring lathe.

After cementing the excess cement is removed with a fine cloth wetted with petrol.

### Stoving (or Baking)

By compressing the two lenses to squeeze out the balsam they are elastically deformed. If the balsam were left to set immediately the lenses would remain deformed, which would spoil their optical qualities

and one day, the tension in the glass supervening, a partial uncementing would be observed (cracking, iridescence). To avoid these drawbacks the cemented lenses should be maintained, in an oven, at such a temperature that the balsam remains pasty. The stoving should continue for at least a day for small lenses and for several days for large lenses.\* It is prudent to keep cemented objective lenses under observation for six months to be assured that they show no iridescence or commencement of uncementing and that they conserve their resolving power.

### Uncementing Lenses

Warm the lenses to melt the balsam. Separate the lenses. When they are almost cooled again wash them with benzene to dissolve the old balsam.

### Preparation of Gum Dammar

This gum, which comes from a tree of the Oceanic Islands, is sold in the form of a more or less brittle resin of a very pale yellow colour. Dissolved in benzene or some other solvent it forms crystal varnish used by photographers to protect their negatives.

In order to be able to purify this gum by filtering it, it is dissolved in zylol (or xylene) which is a product analogous to benzene and is obtained by distillation of wood tar or coal tar. It is filtered hot in order that the solution may be more fluid, using for filtration a very fine silk tissue which has itself been previously warmed.

Having collected a perfectly limpid liquid, one continues to heat it to reduce its volume to about one half by volatilising the xylol, that is to say, until an almost syrupy consistency is attained. If one continued heating, without adding to the solution, after evaporation of the xylol the initial friable resin would be obtained. In order to obtain a sufficiently plastic cement a few drops of castor oil are added to each 100 gm. of the reduced solution and it is boiled for a few seconds in order to stir up the mixture well. The cooking is then continued on a low heat until a drop of the preparation, on cooling, forms a firm pellet taking the imprint of the finger nail.

In order to keep only gum of the suitable consistency, too great a quantity of the cement should not be prepared in advance as it slowly hardens in store.

### Cementing, Stoving, Uncementing

These operations are the same as those for Canada balsam.

\* This procedure should be compared with that described by Twyman (*Prism and Lens Making*, 1942, pp. 75-80) in which a more rapid baking, or annealing, routine is given. (Trans.)

## CHAPTER IX

### RETICULES (CROSS LINES), MICROMETERS AND GRATICULES

Reticules are reference marks placed at the focal plane of an optical instrument and serving to aim it. There are thread reticules, reticules traced on varnished or silvered glass, and engraved reticules.

Micrometers are measuring devices showing divisions, generally numbered, and placed in the focal plane of optical instruments for measuring small angular distances. There are micrometers formed by combs placed at the edges of the field; these are not within the province of the optician but micrometers traced or drawn on glass are of interest to him.

Graticules are glasses which bear graduations or various multiple signs and are placed, like micrometers, at the focus of the eyepieces of certain instruments. There are graticules obtained by photographic procedures; they are not within the optician's province; but those obtained by diamond or acid engraving can come within his competence. Finally, some beautiful graticules have recently been obtained by molecular sputtering (see p. 293).

#### Thread Reticules

Reticule threads are most usually spider webs and sometimes fine platinum wires. These threads are ordinarily 2 to 3 microns in diameter. To obtain this fineness with platinum wire a fine thread of it is coated with silver and the silver-platinum wire is drawn down through diamond draw plates. When the finest possible wire has been obtained by this process the silver which surrounds the platinum is dissolved. This platinum wire is used for making telescope reticules. Spider webs are much more elastic than metallic wires.

#### Spider Webs

Spider webs should be harvested in the summer months, for their quality is better at that time; several species of spider can furnish usable webs. Pieces of web can even be chosen from almost all spider's webs, keeping it in mind that the suspension threads which go from the centre to the support are better than the webs which are stretched in circles. But when good threads are required the following procedure is used.

A large spider with short legs, brown in colour and very hairy, carrying on its back white marks in the form of a fleur-de-lys is sought. A fly is thrown into its web to draw it to the middle and the whole

web, with the animal, is rapidly taken up with a stick. If the stick is tapped with small blows the spider wishes to make off and pays out its web in order to reach the ground. At this instant the thread it pays out is wound up on a wooden or cardboard frame; it is necessary to work quickly enough for the animal not to have time to get to the ground. In this way a great length of web can be drawn from a single spider. In winding up the thread care must be taken to leave a small interval between successive turns, for the elements of thread used should be kept protected from any contact. For the same reason, the frame on which the thread is wound is of such a size that its inner space is a little larger than the largest reticules to be made (4 to 5 cm. for instance). The thickness of the frame is such that opposing strands cannot touch.

### Setting the Reticule

A thin iron wire is prepared, bent in the shape of a "U", in such a way as to leave between the ends of the branches of the U a distance a little greater than the external diameter of the reticule ring on which the thread is to be stuck. The diameters on which the wires should be placed will have been marked on the reticule ring; the marks must be extremely fine (hardly visible).

The cement to be used is a mixture of  $\frac{1}{3}$  of rosin with  $\frac{2}{3}$  of yellow wax, kept at a temperature which renders it almost liquid.

The iron wire U is presented to the frame in such a way that its extremities limit the chosen piece of thread, and a droplet of cement is deposited on each end to attach the spider web to the iron wire. The piece of thread thus seized is separated from the frame and the iron wire U is carried over the reticule ring lying on the table. When the spider thread is exactly over the diameter marked on the ring the iron wire U is allowed to rest freely on the table; in doing this the spider thread is stretched by the weight of the wire. The coincidence of the spider web with the diametrical reference marks is verified and then a droplet of cement is deposited on each end of the thread. Platinum wires are put in place in the same way.

### Traced Reticules

Reticules can be traced with an extremely sharp needle on a layer of varnish or of silver which has previously been coated on a glass plate which is to become the reticular plate.

Silvering is more fragile than varnish; the details of a recommended method of silvering will be seen later.

Here, according to M. Berneau, head of the optical workshop of the Atelier de Construction de Puteaux, are some details of procedure which have been tested.

### *Black Varnish (Composition No. 1)*

Vignette printing ink diluted in a sufficient quantity of genuine oil of turpentine to obtain a liquid easily spread on the glass with a brush. Dry it in the cold for 2 or 3 hours, according to the temperature. If the varnish is too soft the lines will close up again after tracing; if it is too dry it will strip off under the tracing needle. After tracing, let it rest for 12 hours, then heat the reticule on a plate of sheet iron at about 40° C. for 1 hour. The surface becomes matte.

### *Black Varnish (Composition No. 2)*

40 gm. of mourning black (marque Eif of Messrs. Lorilleux, for instance) mixed with 35 gm. of oil of turpentine. Heat the reticular plates on a sheet iron plate at 140° C. for 5 minutes (place a thermometer on the plate). Let it rest for 5 minutes. Continue the heating for 4 hours at 140° C.

### **Tracing Needles**

After various trials, sewing needles have given the best results. They are chosen from among the finest numbers of the best makes; No. 12 of the trade mark "Au bras de fer" is very suitable. These needles are unsuitable for tracing as they are sold; it is necessary to harden and resharpen them. To obtain these results each needle is heated white hot and quenched in mercury, rendering it exceedingly hard. It is then sharpened on a very fine Levant stone with oil.

For this operation the needle is held in a pin vice similar to those used in clockmaking and rolled between the fingers at the same time as it is rubbed, as lightly as possible, on a very smooth Levant stone. The results are examined with a microscope of 150 diameters magnification. The point of the needle thus examined in all directions should still appear very sharp. Such a needle gives lines 7 microns wide on varnish and lines 10 microns wide when acid etching is employed.

### **Engraved Reticules**

Reticules can be engraved on glass reticule plates either with a diamond or with acid.

The execution of reticule plates engraved with a diamond belongs to the general technique of diamond engraving of graticules, numbered micrometric divisions, etc.

## **ENGRAVING ON GLASS**

The engraving of reticule plates, of micrometers, of graticules and other fine inscriptions is made either with a diamond or with acid, by

the aid of precision reducing apparatus called pantographs. They embody an enlarged model formed of a metallic plate cut in intaglio. The guide pin which governs the displacements of the diamond follows the channels of the model.

### Diamond Engraving

Writing diamonds, called "plumes" (pens), which are diamonds turned to a cone shape and mounted in sleeves similar to pencils, are sold. This sort of diamond is barely suitable for engraving thick lines easily visible to the naked eye.

The lines of micrometers, graticules, etc., being destined to be examined with an eyepiece which is often very powerful, should be traced with diamonds of sharp and fine cut. The choice and adjustment of these diamonds calls for a special technique.

Diamond chips set in the tips of soft steel rods are used. Diamonds thus mounted are sold by diamond setters who have chosen an approximately suitable position of the diamond in relation to the rod.

The talent of these specialists consists, notably, of orientating the diamond in such a way that the cleavage faces do not present themselves in a way that favours chipping. The optician must determine, meticulously, the exact slope which the steel rod must have with respect to the surface to be engraved and the direction in which the diamond should be advanced. For this purpose he can employ the following arrangement (Fig. 113).

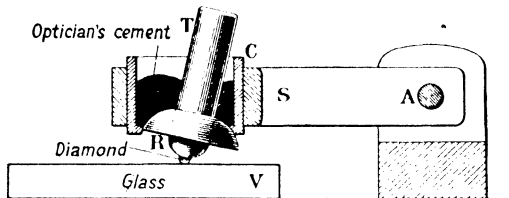

FIG. 113. Apparatus for adjusting diamonds.

The rod carrying the diamond is welded to a spherical bearing whose centre is in the neighbourhood of the diamond point. This bearing *R* presses on the extremity of a hollow cylinder *C*, through which the rod passes, in such a way that very varied inclinations with respect to the hollow cylinder can be obtained without the point of the diamond being appreciably displaced. The rod *T* is held in position by "optician's cement" ( $\frac{1}{4}$  yellow wax,  $\frac{3}{4}$  rosin) which, being malleable when warm, allows of modifications of the adjustment.

For adjustment the cylinder is fixed in an oscillating support *S*

whose axis *A*, mounted between centres, does not allow of any displacement of the diamond and allows it to rest freely on the glass to be engraved. The rod, at first being in any position whatever, the glass is given a circular translatory movement by making it slide on the table. A curly curve (Fig. 114) which is examined with a magnifier or microscope is thus cut. Generally the trace is very uneven and is even doubled in parts. This is because the diamond, whose profiles

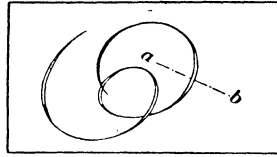

FIG. 114.

seen under a microscope are as irregular as those of a rock, rests on the glass by two points. In order that it shall only rest by one point it must be made to tilt about that point in such a way as to raise up the other point.

The position of the rod being thus modified, the trial is recommenced and the rod is again tilted in a plane normal to the thickest part of the new line. By this method, one can obtain good lines fairly quickly and even find several samples of diamond capable of giving a curly trace perfectly even in every part. These diamonds, thus adjusted, are reserved for tracing figuring or curves on graticules.

Other diamonds will give clear lines, but with thick or thin strokes according to the direction of advance of the glass (or the diamond). By marking the position of the cylinder in its support one can cut, with such diamonds, letters and numbers presenting the thick and thin strokes of "English handwriting" (copper plate) or those of the writing called round hand.

Finally, for tracing micrometer graduations it is only necessary to mark the position of the cylinder giving the sharpest lines of the width desired in the direction of the tracing movement.

The diamond being placed, as has just been said, on the engraving apparatus (pantograph), the execution of the tracing demands the following several precautions.

(1st) Place a suitable load on the diamond, determined by trial. The same load is not suitable for all diamonds; for some the weight of the cylinder and its support alone might be excessive and, if very fine lines are required, the diamond must be lightened by a counterpoise or a spring.

(2nd) Trace slowly (an advance of the order of 1 mm. per second

if the engraving is to be examined with a high degree of enlargement or a little less slowly in the contrary case).

(3rd) Avoid vibrations, by the choice of a suitable locality.

(4th) Avoid jolts and jerks in the movement of guiding pin. Jolts are unavoidable when the guiding pin crosses a transverse line. If, then, a reticule with cross lines has to be cut, the diamond is raised at the moment of crossing the transverse line, leaving a little space not engraved around the virtual point of crossing of the lines. One cannot work in this way if there are numerous crossings, especially if the graticule includes a chequered pattern. In this case two master copies must be employed, one bearing only the longitudinal lines and the other bearing only the transverse ones. Obviously the positions of the two master copies must be very accurately registered on the engraving apparatus.

Of the different methods of engraving micrometers and graticules that have been tried, diamond tracing appears to be the best, but well executed acid etching also gives satisfactory and economical results.

#### **Acid Engraving (or Etching) according to M. Berneau**

The method of working differs slightly according to the glasses used and the nature of the lines to be obtained. After long comparative tests it has been observed that St. Gobain plate glass gives the best results from the point of view of "bite". Attack occurs rapidly, thus the protective varnish (or resist) has only to suffer the action of the acid for a short time. The contour of the lines and figures is sharper and their depth greater, permitting easier blackening and filling. In spite of the advantages which St. Gobain plate glass appears to present from the point of view of etching, it is not generally employed in making micrometers or reticules on account of its lack of whiteness.

It has therefore been necessary to find out which materials responded best to the general conditions called for by a good optical instrument. Boro-silicate crown glass gives the best results from an optical point of view, but it brings in great difficulties in the engraving of mass produced objects, and there are important wastages. The very white glass used in spectacle-making\* best presents the qualities necessary for making a micrometer. Its transparency is almost comparable to that of boro-silicate glass and the engraving which is obtained with this glass is very good. Baryta flint glasses are also very well attacked by the acid.

We will pass in review the different processes which are actually satisfactory, as well as the indispensable accessories for obtaining good results.

The glasses, worked to suitable shapes and dimensions are carefully

\* Extra white glass B from the glassworks of Bagneaux-sur-Loing (Seine-et-Marne).

cleaned in succession with benzene, absolute alcohol and ether. They are put on the metal plate of an electric hot-plate whose temperature must not exceed  $125^{\circ}\text{C}$ . When the glasses have attained such a temperature that they can still be held in the hand, remove them, making use of a slightly spongy cloth, and hold them in the left hand with the face to be engraved turned outwards. With the right hand take up the dropping-bottle containing the protective varnish,\* kept permanently in a water bath.

Pour some drops of the varnish on the glass, inclining the latter in all directions so that the excess is absorbed by the spongy cloth. Prepare, thus, a series of glasses for engraving and let them cool down. The varnished surface becomes matte.

The glasses thus having been prepared, bake the varnish again by replacing them on the hot-plate for two or three minutes only. After the surfaces have become shiny let them cool again, when they will be ready for receiving a trace.

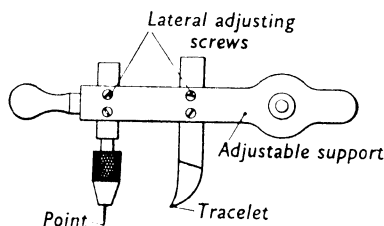

FIG. 115. Tracelet.

Reticules, which consist of straight lines only, are drawn by the aid of tracelets, of which Fig. 115 gives an example. These tracelets, of very hard, tempered steel, can be adjusted to draw lines of different widths. The adjustment is made by rectifying the dimensions of the cutting part by means of an oilstone.

For tracing micrometers embodying numbers or circular lines the tracelet is not suitable. In this case a round point (see p. 274, "tracing needle") is employed.

When verifying the tracing, account must be taken of the widening produced by etching; about 10 per cent. on to the width of lines smaller than 0.02 mm.

In order that the tracing needle shall not be blunted too quickly it should only be very moderately loaded; a load of 6 gm. has given good results. The master copies must be followed with the guiding point of the pantograph, moved by hand, without stiffness. The contacts at the ends of lines must be made gently; without this pre-

\* See p. 281 for the way in which this varnish is prepared.

caution the extremities of the traced lines will make a crook. The precautions to be taken in tracing crossed lines or checkered patterns have been indicated above.

After tracing the glasses are engraved by attack by hydrofluoric acid. For etching, use is made of a small leaden vessel provided with a cover, also of lead, and containing the pure acid, as concentrated as possible (it is worth while getting this acid from a works where renewal is frequent). As hydrofluoric acid has much attraction for humidity, the fact of frequently unstopping the flasks which contain it, im-

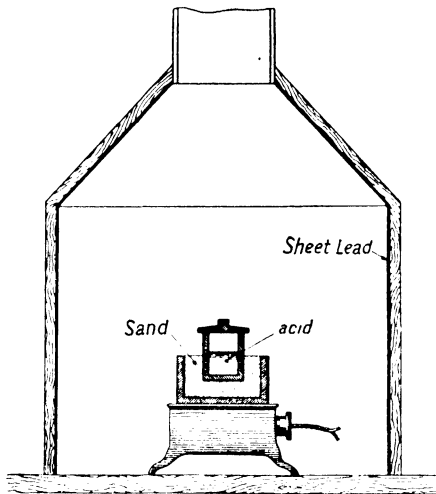

FIG. 116. Heating hydrofluoric acid.

poverishes it and occasions much wastage in etching. The vessel, with the acid, is placed in a sand bath warmed by an electric hot-plate (fig. 116) to about 80° C.

The only purpose of heating the sand bath is to activate the acid vapours. The traced glasses are submitted to these vapours for a time varying from 3 to 5 seconds according to the nature of the glass and the hygrometric state of the atmosphere. To be successful it is prudent to prepare a trial piece before each batch. During etching the glass may be fixed on a piece of wood by means of modelling wax. Whatever the support may be, great care must be taken to protect the second surface against infiltrations of the acid vapour. Directly after etching wash with water to arrest the action of the etching medium and remove the protective varnish with benzene.

The *modus operandi* just described applies to micrometers or reticules which only have a single width of line. Certain instruments fre-

quently have lines for diurnal and nocturnal observations. Those which must serve in the daylight usually have a width of 0.01 to 0.02 mm. according to the magnification of the instruments in which they are used; those which are used at night are about 0.1 mm. wide. It is necessary to operate twice to obtain these different sizes of lines. The first operation consists in tracing the thick lines with an etching time varying from 25 to 30 seconds. This etching is then arrested by washing with water, taking great care not to rub the surface so as to cause scratches. The surface is then dried in a jet of compressed air. It is important that no trace of humidity shall remain. The glass and its mounting are replaced on the engraving machine; the fine lines are then traced and the acid etching should last about 3 seconds. The etching acts on the thick lines again without any drawback.

Some micrometers embody round points. It is fairly difficult to make master copies allowing these points to be conveniently traced. Good results are obtained by making use of an eccentric guide point which can, when desired, be made to turn around the axis of its mounting, the body of the guide point remaining fixed on the axis. In this movement the tracing needle describes a small circle, whose size depends on the eccentricity of the guide point.

The nature of the material whose use is essential for the production of an optical combination sometimes compels the engraving of lenses of boro-silicate crown or other materials more or less refractory to the etching action of acid vapours. It is then necessary to make use of the acid in the nascent state. The following process gives very good results with boro-silicate glass, one of the least well engraved of the materials used in optical work.

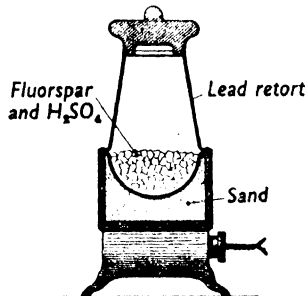

FIG. 117. Retort for acid etching.

For making the acid a small vertical leaden retort, composed of two sections, is used (Fig. 117). The lower part is filled with fluorspar and commercial sulphuric acid at 66° in the proportions by weight of 1 part of spar and 3 parts of acid.

The upper part being replaced and fixed by the clamping screws, the whole, with its stopper, is placed in a sand bath and raised to a temperature of  $100^{\circ}$  C. to  $135^{\circ}$  C. which must not be exceeded. When the first gases come off, the glasses to be engraved, with their mounts, are placed at the upper orifice with their engraved faces turned towards the vapours. The length of etching time is from 5 to 10 seconds for fine lines and about 50 seconds for thick lines. It is as well to trace a certain number of glasses in advance and to work quickly for the evolution of gas is of short duration for a retort of practical dimensions. When the etching operation is finished the retort must be carefully cleaned out and recharged for a new attack.

Whatever may be the method employed and the nature of the lines, it is indispensable to submit the engraved glasses to a meticulous inspection. They are first examined with a lens of sufficient magnification to be assured that no line or number is lost, and then the thickness and length of the lines is verified with a microscope.

*Preparation of Protective Varnish (resist) for Engraving.*—In a wide mouthed jar dissolve 200 gm. (7 oz.) of real Jew's pitch in 250 gm. (9 oz.) of oil of turpentine of 0.850 specific gravity. To obtain complete solution it is necessary to submit the vessel to a temperature of  $25^{\circ}$  C. to  $30^{\circ}$  C. (if the vessel is placed in the sunlight there is less risk of fire) and to stir the product frequently with a glass stirring rod. The whole should have the consistency of honey; to obtain this a little turpentine must be added from time to time to replace that lost by evaporation.

Dissolve separately some pure yellow beeswax in enough turpentine of 0.850 specific gravity to make a syrupy liquor.

These two products must be kept separately in well stoppered bottles. Their mixture constitutes the protective varnish (resist). It should only be mixed a little at a time, as required, for the mixture does not keep well.

Place equal parts of the bitumen and wax solutions in an enamelled evaporating dish. Place the whole in a sand bath at a temperature of about  $30^{\circ}$  C., stir continuously and add enough oil of turpentine to obtain a product which, after cooling, is slightly syrupy. The complete varnish should contain 200 gm. of bitumen and 185 gm. of beeswax in the quantity of oil of turpentine needed to form an easily used varnish.

When the varnish has been prepared for some time the bitumen and the wax dissociate. It is possible to regenerate it by submitting it to a fresh heating for ten minutes as described above.

*Blackening the Lines.*—Good micrometers are blacked, if they are not intended to be used for night observation. The blackening of fine lines up to 0.02 mm. is done with printing ink (EIF ink, specially for

mourning, of Messrs. Lorilleux is very suitable) spread on the glass with the finger. The excess is removed by gentle rubbing on a piece of paper similar to that used for polishing optical glass and the filling is afterwards baked on a hot plate for two hours.

For thick lines a stove drying paint such as is generally used for painting metalwork gives good results. This paint is spread in the same way as for fine lines and baked under the same conditions but for a period of four hours. Glasses engraved in this way can be washed in alcohol without deterioration of the black with which the lines are filled.

Micrometers or graticules which must be illuminated for night observation must be traced on a plate of glass of at least 5 mm. thickness. This plate must present to the illuminant a slightly inclined polished edge, so that a pencil of light coming from the source normally to that edge at its centre will pass through the centre of the engraved face, which should be the back surface of the plate. The best lit lines being those which are parallel to the polished edge, it is usually best for the direction of the light source and the polished face to be inclined at  $45^\circ$  to the horizontal and vertical lines. Light entering by the edge travels in the plate at angles greater than that of total reflection. A certain amount of light finishes by leaving through the lines after several reflections, but it is the light which strikes the lines directly that gives them their greatest brightness. That is why circular lines are only lit brightly at the side nearest the lamp and on the opposite side. The intensity of the lamp should be regulated in such a way that the brightness of the illuminated lines is not too different from that of the objects under observation.

As hydrofluoric acid is very corrosive great precautions should be taken in using it. Persons charged with performing the operations must have their fingers covered with rubber fingerstalls and avoid getting directly over the fumes. It is essential to have, close by where the acid is being used, a vessel containing ammonia water in which the hands can be plunged in case of accident. It is also worth while washing in it, fairly often, the objects used in etching, glass mounts, supports, etc.

### **Very Light Acid Engraving (Société des Lunetiers Method)**

Spectacle glasses often have engraved on them very light marks which do not interfere with vision and are only visible in certain lights, or when a little moisture is deposited by breathing on them. The technique of this engraving differs from that of the engraving of micrometers in the following points.

Instead of varnish, a special wax is employed, which is a mixture of pure beeswax and solid floor polishing wax (*cire de parquet en pain*).

The beeswax, used alone, would form a porous layer which would not sufficiently protect the glass. The beeswax (white wax) and the floor polishing wax are mixed hot in equal proportions, then moulded into cakes and cooled.

The glasses to be engraved are placed on a warming plate. When they have reached the temperature of fusion of the wax a piece of it is rubbed on the face to be engraved, the wax, melting, spreads to form a film of even thickness adhering perfectly to the glass. It is left to cool.

The tracing of the imprints on the wax is executed with a pantograph with a needle whose point, although well sharpened, should present a fairly obtuse angle in order to cut in the wax vee shaped grooves into which the acid will penetrate easily. The operator verifies, by transparency, that the bottom of the groove is perfectly freed from wax and he removes the shavings of wax, raised by the needle, with a bristle brush.

A solution is prepared, consisting of pure hydrofluoric acid diluted with an equal volume of distilled water. The mixture is made up on receipt of the pure acid, in order to lessen the losses of vapour which careful stoppering cannot completely suppress.

At the time of use this solution is again diluted with 100 times its volume of distilled water; this last mixture then contains one part of pure acid to 200 parts of distilled water. To mix the acid and water, the acid must be poured into the water and not the water into the acid, for on pouring the water into the acid a violent reaction might be produced and the acid thrown out of the vessel.

The solution defined above (0.5 per cent. acid) is sufficiently dilute to be employed in the open air without forming vapours dangerous to the operator. He deposits a drop of the solution in the grooves cut by the needle with the tip of a quill, and leaves it there for 5 minutes for an engraving of normal intensity.

After the attack, the drop of acid is put back in the vessel. The glass is warmed in order that the most of the wax can be removed by wiping, and cleaning is finished with petrol.

## CHAPTER X

### METALLISATION OF MIRRORS

#### MIRRORS OF THE PAST, THE PRESENT AND THE FUTURE

The first mirrors were metallic mirrors; from olden times mirrors of gold, of silver and, above all, of bronze have been preserved; later on, special alloys for mirrors were made. The surfacing of these metallic mirrors has been described on p. 93.

It is since the sixteenth century that, following the progress in making glass and the invention of the silvering process, mirrors of glass thus metallised have supplanted metallic mirrors. In former times, as to-day, the reflecting surface, properly speaking, was metallic. The silvering of former days was an amalgam of tin (tin and mercury).\*

In the second half of the nineteenth century and up to the present day hardly any mirrors but those of silvered glass were made.

The recipes for silvering are numerous: they can be classed in two categories, both of which consist of reducing a silver salt in solution. The recipes in the first category include the use of a reducing bath of invert sugar, that is to say, a bath of sugar solution on which has acted an acid that transforms it into glucose and laevulose and which thus acquires the property of turning the plane of polarisation to the left instead of making it turn to the right (hence its name) as does a solution of ordinary sugar (see rotary polarisation, p. 232). The recipes of the second category use formaldehyde for reducing the silver salt.

From among all these processes we have chosen one of the first category, details of which follow. This process is one of the best, but its use is not obligatory.

#### Silvering and Semi-Silvering (after M. Berneau)

The process described hereafter is the Brashear process slightly modified. It is equally suitable for silvering mirrors which must reflect the light by their exterior face (telescope mirrors), for ordinary mirrors which reflect the light through the glass, or for half-silvering used in laboratories in order to reflect one part of the light and allow the rest to pass.

The temperature of the place in which silvering is done is very important, for the reactions only operate normally between 18° and 22° C.

The objects to be silvered are stuck on to glass rods in such a way as

\* Still used for some special uses, as, for instance, for coating the back-reflecting surface of quartz Littrow spectrograph prisms as well as for most domestic looking-glasses. (Trans.).

to present the surface to be silvered towards the bottom of the crystallising dish in which the operation should be carried out (Fig. 118).

After sticking-on, the cleaning of the pieces should be done with the greatest care with benzene (benzene crystallisable), then with alcohol, finally with ether. After this cleaning the piece is washed in nitric acid at 40°, then, in succession, in running water, with ammonia and with distilled water.

After the operation of cleaning the pieces are kept in distilled water until the moment of silvering.

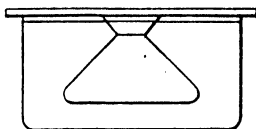

FIG. 118.

All the products used must be as pure as possible. All washings must finish with distilled water and the greatest care for cleanliness must be exercised in all operations.

The bath consists of the three following solutions.

Silver bath	distilled water	100 c.c.
	crystalline silver nitrate	10 gm.
Soda bath	distilled water	100 c.c.
	pure soda	10 gm.
Reducing bath	distilled water	3400 c.c.
	light yellow sugar candy	300 gm.
	10 per cent. of tartaric acid	300 c.c.
	90 per cent. alcohol	50 c.c.

To make up the final bath take 64 c.c. of the silver bath and pour it into a 1000 c.c. flask; pour into this bath, drop by drop, pure ammonia so as to form a brown precipitate and continue to pour in the ammonia until the precipitate is redissolved to obtain a clear solution.

Shake the flask continually during the preparation of the ammoniacal silver bath.

After having carefully rinsed out the measuring cylinder, measure out 64 c.c. of the soda bath, which are poured into the ammoniacal silver bath previously obtained; a black precipitate is formed, which must be redissolved, as the first time, by the addition of ammonia. It is as well, in order not to have an excess of ammonia, to let some light floccules of silver remain in the bath.

To this whole add 640 c.c. of distilled water and keep this solution up to the moment of silvering.

Again rinse out the measuring cylinder and measure out 100 c.c. of the reducing bath.

Prepare the pieces to be silvered in a very clean crystallising dish of convenient size so that the objects are neither too close to the edges nor to the bottom.

Mix the reducing bath with the ammoniacal silver bath, while stirring, and pour them quickly into the crystallising dish. Gently move the pieces about to disengage air bubbles, and let the silver deposit itself on the surfaces. The liquid first becomes pale yellow, then browns to become a grey-black. After an instant the surface is covered with metallic silver and silvering is complete in 30 minutes. The brown colour manifests itself too rapidly when the room temperature is too high; it manifests itself too slowly when the room temperature is too low.

The operation must be arrested after a few minutes' immersion if it is desired that the layer of silver shall be transparent.

If, on the contrary, a very resistant layer of silver, solely for reflecting light, is desired, three superposed layers are deposited by repeating the above described operation twice more, each time for 30 minutes.

The silver thus deposited in three layers does not yet possess its best reflection factor, but it may be polished and acquires a beautiful polish which can be protected with a layer of collodion. The polishing is done dry and by hand, with a little ferrous oxalate, or English rouge, crushed and then sieved with special care. The polisher consists of a simple wad of chamois skin, stuffed with cotton wool. Unfortunately, in spite of every precaution, this practice produces very fine scratches on the polished silver.

#### **Coppering the Silver Layer (according to M. Berneau)**

When the mirror has to reflect through the glass (ordinary mirror) it is easy to protect the layer of silver. The protection obtained by electrolytic deposition of a layer of copper is excellent. Searchlight mirrors whose silvering is coppered can resist temperatures about 200° C.

*Apparatus necessary* (Fig. 119)

1st. A cell (accumulator jar, for instance) having approximately the following dimensions:

Length	..	..	..	200 mm. (8 in.).
Width	..	..	..	120 mm. (4¾ in.).
Height	..	..	..	180 mm. (7 in.).

2nd. Two pure copper anodes, riveted to a support which catches on the upper part of the cell (Fig. 119 and 120).

3rd. Metal tongs for holding the pieces during the operation.

*Preparation of the Bath.*—Put into the cell 4 litres (7 pt.) of distilled water in which have been dissolved pure copper sulphate to saturation and 20 c.c. (1 oz.) of pure sulphuric acid (66°).

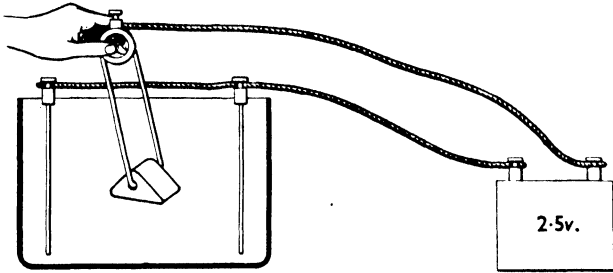

FIG. 119.

The two anodes are placed at 180 mm. (7 in.) from one another (Fig. 119).

The current is provided by a 2.5 volt accumulator (two cadmium-nickel elements, for example \*). The dimensions and distances of the anodes being properly observed the current should be 1 ampere for 25 sq. cm. of silvering to be covered.

After a prolonged washing in running water and then with distilled water, seize the silvered piece in the appropriate tongs, plunge it into the coppering bath and keep it there for about a minute.

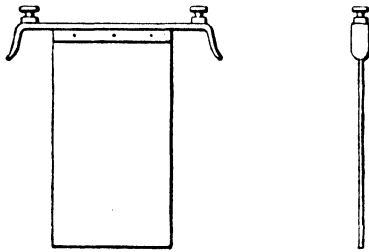

FIG. 120.

The tongs are connected by a flexible wire to the negative pole of the accumulator.

When the operation is finished, wash the piece a long while in running water and then in distilled water. Dry completely (if possible in a current of warm air) to avoid subsequent oxidation.

\* Or a single cell of the normal type of lead plate cell. (Trans.)

**RECENT RESEARCHES ON NEW TYPES OF MIRROR**

The silvering of mirrors has become such a normal practice that it might be believed to be finally settled. Nevertheless other, very recent, methods of metallisation seem likely to modify the technique of mirror making profoundly. First of all, is the choice of glass as a support for a reflecting film indispensable? The choice is inevitable in the case of the mirrors in common use, for the reflecting surface, in order to be well protected, is placed behind its support. This support must be perfectly transparent and hence must be in glass.\*

But glass is fragile, it is harmed by shocks or big variations in temperature. Now all instruments of war are subject to shocks, while glass searchlight mirrors crack from the effect of the heat of the light source and from sudden cooling. In scientific instruments the ordinary types of mirror have many drawbacks. They require that the two surfaces of the glass shall have been optically worked, while it suffices to work the single reflecting surface of a metallic mirror. If the reflecting surface is behind the glass the other surface gives a visible but less luminous image. This image is harmful; it is a parasitic image which it is useful to be rid of. It seems, then, that it would be advantageous, at least for scientific uses, to renounce glass and construct mirrors in an opaque substance of which there is but one reflecting face to be surfaced, but that substance, for mirrors, must combine two conditions. It must be susceptible of receiving a high polish, and have a very high reflection factor. This second factor disappears if a film of a metal having a good reflection factor can be deposited on a well polished surface.

For mirrors silvered or gilded on the exterior, glass has been chosen, up to the present, on account of the very good polish which it is susceptible of receiving, and because opticians know very well how to surface it, but it is difficult to cast it in a mould of slightly complicated form; it is extraordinarily sensitive to tempering † in the air when it has just been poured; it does not allow of welding; to obtain large mirrors of acceptable weight a cellular construction has been tried, without much success, whose cells, destined to assure rigidity, were stuck to the body of the mirror. The problem would be much simplified if one could cast a one-piece cellular mirror in a suitable material, but this substance must be susceptible of as good a polish as glass, for the metallic reflecting film which it must support is so thin that it reproduces the grain of its supporting surface.‡ The technique of alloys

\* Possibly some of the transparent plastic materials such as "Perspex" may have future applications in place of glass. (Trans.) † Straining, see p. 226. (Trans.)

‡ In the case of the famous 200 inch telescope use has been made of a high silica glass (Pyrex) of exceptionally low expansion with a cellular construction. (Trans.)

has made such progress in recent years that it can be hoped that this problem may be resolved and then the glass mirror will probably be a thing of the past.\*

Silver is not the ideal metal for mirrors; when the layer of silver is not protected on both sides it alters rapidly, and the various varnishes tried for protecting it can cause iridescence and diminish the resolving power of the mirror a little. The reflection factor of silver, about 0.9 in the yellow, diminishes with time and often falls below 0.5, but, above all, it diminishes with the wavelength until it descends to a figure of 0.05 for ultra-violet wavelengths in the neighbourhood of  $0.3 \mu$  (3000 Å). In this region, known as "the hole in silver", silvered mirrors are unusable. Nickelled mirrors, for instance, which have a reflection factor less good than that of silvered mirrors for radiations between the blue and the yellow are very superior for radiations near the "hole in silver".†

Two recent methods each permit the deposition of a metal in a very thin coating without recourse to the use of a salt solution, but both necessitate working in a vacuum, which implies a complicated installation and very robust equipment if the mirrors to be metallised are at all large.

#### Method of Metallisation by Cathodic Sputtering ‡

In this process the metal, coming from a plate serving as cathode, is projected on to the glass, placed a little way away, by the passage of an electric current at high tension, through a gas at very low pressure. The whole arrangement must be placed under a perfectly gas tight vacuum bell jar.

Most metals can be deposited in this way on glass in a thicker or thinner layer according to the duration of the operation. Silver, platinum, gold and palladium are the metals most easily deposited.

This method is particularly adapted to the production of very thin layers of metals which are consequently transparent. It has only been applied to relatively small surfaces; its use for large pieces would probably be difficult.

#### Process of Metallisation by Evaporation of the Metal in a Vacuum

This process seems to give even more satisfactory results than all the preceding ones.

\* Ch. Fabry, *Rev. d'Optique, t. et i.*, Oct., 1934, p. 348 *et seq.*

† When the back surface can be used a tin-mercury amalgam is as satisfactory as anything. Front surface mirrors of stainless steel are good reflectors in the whole spectrum and can readily be optically polished while aluminium deposited by evaporation is also good. (Trans.)

‡ Ch. Fabry, *loc. cit.* See also J. Strong (1940), *Modern Physical Laboratory Practice* (Blackie). (Trans.)

Above the surface to be covered are placed wires of the metal which it is desired to use, wires which can be heated by an electric current. The whole is placed in a gas tight chamber wherein an almost perfect vacuum must be made. As soon as the wire is taken to a sufficiently high temperature (nevertheless, much lower than its melting point) the metal evaporates and the vaporised molecules are projected with a velocity greater than that of a rifle bullet. If this velocity is not too much retarded by collision with gaseous molecules, the metallic molecules approach the piece to be metallised with sufficient force to adhere to it firmly.

The heating can be produced in various ways. In certain cases it can be obtained by the passage of current in the wire to be evaporated. In other cases (chromium), the metal should be deposited electrolytically on a tungsten wire in which the current is made to pass. Finally, in the case of aluminium the wire of that metal is generally heated by means of a helix of tungsten wire which is used solely for heating and surrounds the aluminium wire.

Up to the present the metals which have given worth-while results are chromium and aluminium.\* Chromium gives a layer which seems perfectly stable and is remarkably adherent to glass; it can even be said to be only too firm, since it is very difficult to remove. The reflection factor for the visible is decidedly inferior to that of new silver (it is about 0.6), but it does not become any weaker with time. This reflection factor does not present the anomaly in the ultra-violet that that of silver does. For chromium the factor 0.68 is found for  $0.345 \mu$  (3450 Å) and 0.62 for  $0.29 \mu$  (2900 Å). Hence a chromium plated mirror may be used in the ultra-violet.

But the most remarkable results have been given by layers of aluminium, recently introduced into telescope technique. Less adherent than layers of chromium, the layers of aluminium can be removed with hydrochloric acid; nevertheless, up to the present, they appear to be perfectly stable. On the other hand, their reflecting properties are quite remarkable. For visible radiations the reflection factor of aluminium is hardly inferior to that of fresh silver, and, consequently, much better than that of slightly tarnished silver. This reflection factor is almost constant throughout the whole extent of the spectrum including the ultra-violet. According to B. K. Johnson † it varies between 0.83 and 0.87 for wavelengths between  $0.36 \mu$  and  $0.1936 \mu$  (3600 and 1936 Å) the value of 0.70 is still obtained at  $\lambda = 0.1863 \mu$  (1863 Å).

These qualities are of a nature to render great services in astronomy

\* These metals have since been added to. Rhodium is quite commonly used and is very durable. (Trans.)

† B. K. Johnson, "Reflecting power of Aluminised Surfaces", *Nature* (1934), **134**, 216. (Trans.). See also Sabine, G. B. (1939), *Phys. Rev.*, **55**, 1064.

and spectroscopy. As Spencer-Jones remarks in an article published in the English journal, *Nature*,\* it is probable that the mirror covered with aluminium will completely replace the silvered mirror.

Although the first publications on mirrors plated with aluminium by vacuum evaporation, which date from 1933 and 1934, have appeared abroad, the question was investigated, independently of what was done elsewhere, in France and M. Louis Dunoyer, of the Institut d'Optique théorique et appliquée obtained, from the month of March, 1932, very beautiful mirrors of various metals.† He has now completely mastered this technique, and, following his methods, the Société S.C.A.D. is able to deliver mirrors of aluminium plated on glass or on metal, opaque or semi-transparent.‡

In this manufacture the difficulties to be overcome are principally related to the method of establishing a heating system for vaporising the metal and of obtaining the degree of vacuum suitable in a vacuum bell jar, which, having a diameter at least equal to that of the mirror, must support, under the effect of atmospheric pressure, an enormous force if the mirror is large. Nevertheless, the problem has been resolved even for the mirrors of large American telescopes.

The degree of vacuum depends on the surface to be covered and should be as much better as the surface is larger. In order that the molecules of the vaporised metal should encounter the smallest possible number of gas molecules of the residual atmosphere before striking the surface on which they should adhere, the mean free path of the molecules of gas of the residual atmosphere should be of the order of the greatest distance between the vapour source and a point on the surface to be covered. The atoms or molecules of vapour thus correspond with the "atomic or molecular rays" of the type of those first discovered by M. Dunoyer in 1911 and in which he has shown great interest.

If the source is a point one, the thickness of the deposit obtained in a given time obeys the law of the cosine of the angle of incidence. This can be very favourable if it is proposed to obtain, precisely, a

\* Spencer-Jones (1934), "Aluminium Surfaced Mirrors in Astronomy", *Nature*, **134**, 522. A bibliography of the subject is given in this article. Among the already numerous papers the following must be cited. Same author, same title (1934), *Nature*, **133**, 552. R. C. Williams and G. B. Sabine (1933), "Evaporated Films for Large Mirrors", *Astrophys. J.*, **77**, 316. F. E. Wright (1934), *Lick Observatory Bulletin*, No. 459. J. Strong (1934), *Public. Astro. Soc. Pacific.*, **46**, 18. (This article contains a description of the methods employed at the California Institute of Technology at Pasadena.) Also, J. Strong (1940), *Modern Physical Laboratory Practice* (Blackie). (Trans.)

† This information and the following have been furnished by M. Dunoyer (*C. R. Acad. Sci.*, Paris, 1936, Feb., 1936).

‡ Société de Construction d'Appareils de Laboratoires, 135, rue de Théâtre, Paris 15. Firms in Great Britain offering similar services include Messrs. Adam Hilger Ltd., and Messrs. Pilkingtons. (Trans.)

gradually varying opacity. On the other hand, it constitutes an important difficulty when it is proposed to obtain a layer of uniform thickness.

To resolve this difficulty, the idea which first presents itself to the mind consists in removing the source as much further away as the surface to be covered is larger, in such a way that the smallest cosine of the angle of incidence is still very near to unity. But this method demands, as has been said above, that the degree of vacuum should be as much better as the surface is larger, and as a given degree of vacuum is as much less easy to obtain as the volume in which it is wished to be realised is greater, it is seen that the difficulties, if they could be assigned a numerical value, would increase as a high power of the characteristic dimensions.

One way of overcoming the difficulty consists in disposing in front of the surface to be covered a certain number of sources of vapour at a smaller distance than a single source should be. The mutual distance of the sources of vapour must, naturally, form the object of careful study so as to realise as uniform a layer as possible. The problem is the same, on the whole, as that of producing uniform illumination on a public square. The higher the degree of vacuum which is obtainable the further off the sources can be placed, and the fewer they can be. One of the advantages which there is in not putting them too far off (even when the degree of vacuum which can be obtained is high) is that at least the dimensions of the chamber in which the operation takes place can remain moderate. One can, for example, thus metallise a large mirror in a sort of large flat bell, suitably ribbed to resist the pressure and much more easily handled and cleaned. In a flat bell a very good vacuum is more easily obtained than in a bell of the same cross section but having all the height which is suitable for the use of a single source of vapour. It is thus that the 90 cm. diameter mirror of the Lick Observatory has been successfully done, and, more recently, the large mirror 2.50 metres in diameter of Mount Wilson Observatory. The bell which covered this mirror supported an atmospheric pressure of about 50 tons.

Finally, a third way of overcoming the difficulty, which M. Dunoyer, according to his published work, was the first to employ, consists of obtaining a relative movement of the source and the surface,\* so that the whole surface is sprayed as if with a molecular jet. This process is particularly suitable for obtaining mirrors some centimetres in width, and of some length.

We may here point out two interesting advantages of metallisation by evaporation *in vacuo*.

I. As the deposited metallic layer clings exactly to all the surface

\* Brevet français, No. 388545.

defects it shows them up in a surprising manner, revealing polishing defects which are not suspected from direct examination of the mirror surface before metallisation.

II. When the metallic layer is suitably prepared it seems to have only an extremely slight diffusing power, and this is a very marked quality of mirrors obtained by vaporisation *in vacuo*. Other mirrors demand polishing, even mirrors of silvered glass (when one wishes to use them from the metallic side of course). This polishing (see p. 286) always leaves numerous little scratches and however slightly visible they may each be, their number and length cause more diffused light than is given by well polished glass mirrors well metallised *in vacuo*.

### Graticules obtained by Molecular Sputtering

As a consequence of the constitution of atomic or molecular jets or rays, if the vapour source is sensibly a point one and the vacuum is sufficiently good, objects interposed between source and surface give sharply projected shadows, on which no deposit is produced. As the source is never rigorously a point source nor is the vacuum perfect, the shadows are, naturally, sharper as the objects are closer to the surface. M. Dunoyer has thus \* been able to obtain, on glass surfaces, varied designs and inscriptions whose fineness and sharpness of contour are remarkable.

This process is susceptible of numerous applications. It will be suitable, for instance, for leaving prearranged clear spaces on a surface to be metallised (whether one wishes to use its reflecting power or its transmission), or even for obtaining graticules of full contrast for optical instruments, as fine as may be desired and readily identical, one with another. This technique depends entirely upon the predetermined establishment of the grid work (or stencil) necessary for arresting the molecular rays except in the regions to be metallised.

\* Brevet français, No. 388546.



## NAME INDEX

- |   |   |
|---|---|
| <p style="text-align: center;">A</p> <p>Arnulf, A., 13<br/>Atelier des Constructions de Puteaux, 50,<br/>273</p> <p style="text-align: center;">B</p> <p>Berneau, 273, 277, 284<br/>Bontemps, 9<br/>Bruhat, G., 229</p> <p style="text-align: center;">C</p> <p>Chance Bros., 9</p> <p style="text-align: center;">D</p> <p>Dunoyer, L., 291, 292</p> <p style="text-align: center;">E</p> <p>Ecole supérieure d'Optique, 4<br/>Edison-Swan Electrical Co., 13</p> <p style="text-align: center;">F</p> <p>Fabry, Ch., 289<br/>Feil et Guinand, 9<br/>Feil et Mantois, 9, 10<br/>Foucault, 203, 242<br/>Fraunhofer, 184<br/>Fritsch, J., 30, 31, 32, 33</p> <p style="text-align: center;">G</p> <p>Glazebrook, R., 243, 244<br/>Guinand, 9</p> <p style="text-align: center;">H</p> <p>Hewittie Electric Co., 181<br/>Hilger, Adam, Ltd., 13, 59, 205, 215, 217,<br/>291</p> <p style="text-align: center;">I</p> <p>Institut d'Optique, 13, 78, 90, 104, 158,<br/>214, 291</p> <p style="text-align: center;">J</p> <p>Jarret, 208<br/>Jobin et Yvon, 184<br/>Johnson, B. K., 290</p> | <p style="text-align: center;">K</p> <p>Kodak Ltd., 7</p> <p style="text-align: center;">L</p> <p>Laurent, 184<br/>Lick Observatory, 292<br/>Lorilleux, 274, 282</p> <p style="text-align: center;">M</p> <p>Mackinsen, O., 68<br/>Malus, 227<br/>Massiat, 31, 32<br/>Michelson, A. A., 206<br/>Mount Wilson Observatory, 292</p> <p style="text-align: center;">N</p> <p>Nicol, 227, 239<br/>Norremberg, 228, 229</p> <p style="text-align: center;">P</p> <p>Parra-Mantois et Cie, 9<br/>Pilkington, 291</p> <p style="text-align: center;">R</p> <p>Ritchey, G., 53, 197<br/>Rochon, 244<br/>Ross Ltd., 217</p> <p style="text-align: center;">S</p> <p>Sabine, G. B., 290, 291<br/>Sénarmont, 244<br/>Simeon, F., 11<br/>Smith, R., 93<br/>Soc. des Lunetiers, 282<br/>Soc. S.C.A.D., 291<br/>Spencer-Jones, H., 291<br/>Strong, J., 289, 291</p> <p style="text-align: center;">T</p> <p>Thompson, 242<br/>Twyman, F., 11, 34, 40, 45, 55, 59, 184,<br/>203, 206, 226, 260, 271</p> <p style="text-align: center;">W</p> <p>Williams, R. C., 291<br/>Wollaston, 244<br/>Wright, F. E., 291</p> |
|---|---|

## SUBJECT INDEX

### A

- Aberrations, chromatic, 4
  - compensation of, 6
  - spherical, 4
- compensation of, 7
- Abich's mortar, 23
- Abrasives, 17
  - action of, 41
  - choice of, 21, 80
  - effect of drying up, 154
    - moistness on velocity of work, 132
  - for Iceland spar, 245
    - quartz, 237
    - grading of, 18
      - precautions in, 21
  - homogeneity of, 42, 48, 122
  - mean grain size of, 57
  - recovery of worn, 19
  - refining, 42, 58
  - variation in pressure with size of, 53
  - wetness of, special tools for controlling, 122, 132
- Acetic acid, glacial, 34, 49
- Achromatic lenses, 7
- Adjustable relative rotations, lathe with, 78, 90, 140, 144, 148, 153, 154, 158
- Airy's spirals, 229, 230
- Akro lenses, 112
- Alcohol, rectified, 49
- Alumina, powder, 22, 26, 250
  - silicate of, 26
- Aluminised mirrors, 290
  - reflectivity of, 290
- Aluminous silicate, 26
- Ametropia, 100
- Analyser for polarised light, 225
- Anastigmat, 9
- Angle Dekkor, 215, 220
- Angles, direct measurement of, 214
  - how to make 90° and 45°, 209
  - precision of, 210
  - tests of, 208
    - by autocollimation, 216, 218
    - 15° and multiples, 213
    - 30°, 60° and 120°, 22
    - Jarret's method, 208
    - right-angle, 218
- Anisotropic substances, 225
- Aplanatic objective, 6, 9
- Aragonite, 26
- Arnulf's method of testing for veins, 13
- Aspherical surfaces, 166, 194, 196
  - test plates, 196

- Astigmatism, 8, 100, 107
- Autocollimating telescope, 215, 218
  - viewer for centring, 255
- Autocollimation, principle of, 214
- Automatic braking of tool, 140
  - lathe, 59, 61, 73, 77, 122, 133, 140, 144, 148, 152, 153, 154, 158, 160, 166
    - adjustment, 59, 68, 125, 82, 85, 98
    - economics of use, 60
    - ratio of movements, 59, 85
    - technique of working, 59, 72, 73
- Automatic machine—see Automatic Lathe
  - velocity of rotation, 127, 144
- Axes of crystals, determination of, 234
  - marking, 235
  - setting to, 228
  - tools, inclination of, 76, 153, 158

### B

- Baking cemented lenses, 271
- Ball-and-socket drive, 59
  - handle, 61, 65, 167
- Balsam, Canada, 30, 240, 242, 243, 268, 270
- Baryta-flint glass, etching properties of, 277
- Base-curvature of spectacle lenses, 107, 108
- Beeswax, 27, 283
  - and rosin cement (see Optician's Cement), 27.
  - in polishers, 46
- Benzene, 49
- Berzelius paper, 47
- Best driving-point, 63, 168
  - for planes, 168
  - spheres, 63, 170
  - glass for engraving, 277
  - method of grinding, 131
- Bevel gauge method of testing angles, 208
- Biconvex and biconcave lenses, 101, 106
- Bifocal lenses, 110
- Birefringence, 225
- Black cement, 29, 44, 49
  - sealing wax, 29
- Blackening etched lines, 281
- Blocking cylindrical lenses, 88
  - importance of manner of heating in, 90
  - in cement, 39
  - plaster, 34
  - tools, 34, 39
  - size of, 39
- Blotting paper for polishers, 47

Bluestone, 24, 94  
 Boort, 248  
 Boric acid in glass, effect of excess, 3  
 Boro-silicate crown glass, 277  
 Braking, automatic, 65, 75, 140, 162  
   by hand, 73, 75, 166  
 Brushes, 49  
 Brutage, 249  
 Bubbles in glass, 12, 13

## C

Caillebottage (see Scouring)  
 Calc-spar (see Iceland Spar)  
 Calculating distribution of wear, 133, 134  
   weight for polishing machine, 95  
 Callotte, 38  
 Canada balsam, 30, 240, 242, 243, 268  
   cementing with, 270  
   preparation of, 270  
   refractive index of, 241  
   storing of, 270  
 Canon, 234  
 Carbonado, 36  
 Carborundum, 17, 21, 22, 49  
   grading and washing of, 22  
   uses for, 22  
 Cardan joint for polishing, 79, 251  
 Cast iron for optical tools, 40  
 Castor oil as cement, 268  
 Caustics, 4, 5, 6  
 Cells for liquids, 27  
 Cement (see also Canada Balsam)  
   black, 29, 44, 49  
   castor oil as, 268  
   cellulose acetate, 33  
   choice of, 27, 267  
   colourless, 32  
   distortion caused by, 93  
   effect of thick layer of, 267  
   for cross webs, 273  
   for glass to brass, 28  
   French, or Spanish White, 29, 44  
   Massiat's, 32  
   oil, 27, 28  
   optician's, or wax, 27  
   Ostwald's, 28  
   pitch and wax, 254  
   Serbat's, 28  
   shellac, 30  
   strain in, 27, 271  
   thickness of in block, 39  
   transparent, 32  
   water-glass, 32  
   waterproof, 31  
 Cemented bifocal lenses, 110  
   surfaces need not be perfect, 268  
 Cementing fabric polishers, 43  
   lens, reasons for, 267  
   preparing lens for, 269  
   with Canada balsam, 268, 270  
 Centres of rotation, instantaneous, 116,  
   122, 129, 135, 143, 148  
   relative positions of, 120, 130, 148  
 Centring, accuracy of, 252  
   and edging smoothed lenses, 260  
   spectacle lenses, 261  
   autocollimating viewer for, 254  
   best side to work from in, 254  
   bicylindrical lenses, 265  
   cement for, 254  
   cylindrical lenses, 262  
   doublet lenses, 257, 258  
   effect of imperfect, 252  
   final of cemented lens, 269  
   light source for, 256  
   machine, 253, 254  
   marking lens components in, 257  
   method of, 256  
   microscope objectives, 253  
   plano-cylindrical lenses, 264  
   spectacle lenses, 261  
   sphero-cylindrical lenses, 265  
   tube, 253  
   viewing device for, 254  
   with a light, 253  
 Cerium oxide, 17, 26  
 Chamfering spectacle lenses, 261  
 Chamois leather, 49  
 Chemical grey, 49  
 Chocks (blocks), 65, 75  
 Chromatic aberrations, 4  
 Chromium evaporation, 290  
   reflection of, 290  
   sesquioxide, 26  
 Cleaning materials, 49  
 Cleanliness, 21, 49, 50  
 Cleavage planes of crystals, 232, 239, 244,  
   246, 248, 249  
 Cloth polishers, 25, 29, 43, 110  
   and pitch polishers, 46, 94, 99  
   waxed polishers, 46  
 Coefficient of braking, 119  
   friction, 168  
 Colcothen, 17, 25, 28, 43  
 Colophony, 27  
 Coloured glasses, 3  
 Colours of thin films, 177  
   working to, 177  
 Cone mounting for tools, 37  
 Convergent lenses, aberrations of, 6  
 Coppering on silvering, 286  
 Cornea, 100  
 Correction of surfaces, 72, 80, 91, 167  
   tools (see Trueing-up Tools)  
 Corrective lenses, prescription for, 103  
 Corundum, 18, 22, 24, 25, 26, 236  
   coloured, 250  
   jewel bearings from, 250  
   nature of, 250  
   synthetic, 22, 250

Corundum, working of, 250  
 Cotret, or lens carrier, 55  
 Coulomb's Law, 126  
 Crookes glass, 3  
 Cross webs (see Reticules)  
 Crystals, axes, setting to, 229  
   biaxial, 226, 232  
   birefringent, 226  
   choice of abrasives for, 235  
   cleavage of, 232, 239, 244, 246, 248, 249  
   cubic, 232, 246  
   cutting of, 232 *et seq.*, 237, 238, 240, 243, 244, 246, 247, 248, 249, 250  
   defects of, 233  
   hardness of, 235  
   preferred direction of polishing for, 235, 244, 245, 246, 249  
   refraction of, 225  
   rings and cross in, 229  
   uniaxial, 232, 233  
 Cube, tests of angles of, 219  
 Cuirasse for blocking tools, 40  
 Curvature, alteration of in polishing, 194  
   measured with dissimilar test plates, 188, 194  
   measurement of, 104  
 Curves, shallow, tests of with proof plane, 185  
 Cutting away the polisher, 72, 75, 80, 91, 165  
 Cylindrical block, 62, 83, 88, 99  
   technique of polishing 62, 83, 99  
   dipters, 103  
   lenses, centring of, 262  
   setting axes of, 83, 89, 108, 262  
   test plates, 195

## D

"Daylight" test of tools, 221  
 Deeply curved surfacing, 78, 165  
 Defects in crystals, 233  
 Determining axis of crystals, 234  
 Deviation of spectacle prism, 106  
 Diamantine, 26  
 Diamond, 236  
   abrasive, 23, 250  
   adjustment for engraving, 275  
   cleavage of, 232, 249  
   crushing of, 23  
   drawplates, 249  
   drilling, 36, 249.  
   dust, 17, 35, 249  
   engraving with, 275  
   grinding disc, 251  
   load on for engraving, 276  
   polishing, 249  
   preferred direction in, 249  
   powder, 17, 22, 26

Diamond, refraction, index of, 248  
   sawing, 35, 248  
   tools, 248  
   writing, 275  
 Diffraction, 14  
   of images of specks, 15  
 Diopters, 100, 101  
   cylindrical, 103  
   frontal, 102  
   prismatic, 106  
 Dioptrimeters, 101  
 Dispersion, 7  
   partial, 11  
   ratio, 11  
 Dispersive power, 7, 8, 11  
 Distribution of pressures on a curved tool, 146  
   cut-away polisher, 147  
   wear, 118, 156  
   calculation of, 138  
   on spherical surfaces, 141  
 Dopp, 249  
 Double image prisms, 244  
   refraction, 225  
 Drilling glass, 36  
   avoiding chips in, 36  
   speed of drills for, 36  
 Driving pins, ball-pointed, 158  
   effect of position of, 62  
   track of, 155, 162  
   point, optimum, 63, 168  
 Drying abrasive, effect of, 67, 154  
 Dusters, 49

## E

Ebrutage (see Brutage)  
 Eccentricity of track, 139  
 "Edge-off", 60, 73, 133, 169  
   effect, avoidance in hand working, 60  
   less evident with automatic lathes, 61  
   with spherical surfaces, 65  
 Edging a stack of discs ("truing"), 54  
   avoiding chips in, 258  
   lever machines for, 260  
   machines, 260  
   position of grinding wheels in, 260  
   smoothed lenses, 260  
   spectacle lenses, 261  
 Egrisé, 23, 249  
 Elastic deformations, 92  
 Elutriation of abrasives, 18  
 Emerald, 250  
 Emeries, 17, 18  
   adulteration of, 18  
   colour of, 18  
   consistency of, 42  
   grades of, 18

Emeries, grading of, 18  
 precautions in, 21  
 humidity of, 42  
 mean grain sizes of, 57  
 metallic impurities in removal of, 20  
 recovery and washing of, 19  
 refining of, 42, 58  
 wear of in the tools, 41

Engraving acid, 277  
 best glass for, 277  
 choice of diamond for, 275  
 cross lines, 277  
 load on diamond for, 276  
 on glass, 274  
 with diamond, 275

Euphos glass, 3

Evaporation process for graticules, 293  
 of metallisation, 289 *et seq.*  
 thickness of layer, 292  
 vacuum required for, 291  
 use of moving electrodes, 292  
 multiple electrodes, 292

Etched line illumination, 282

Etching, 279  
 best glass for, 277  
 chamber for, 279  
 night and day lines, 280  
 preparation of resist for, 281  
 of glass for, 278  
 retort for, 280  
 varnishing glass for, 278  
 very light, 282  
 wax resist for, 282  
 width of lines in, 278

Example of working out a system of grinding, 133

Examples of calculating surfacing particulars, 95 *et seq.*

Exercises on surfacing problems, 95 *et seq.*

Extraordinary image, 225  
 ray, 225, 233, 239, 241, 247

Eye, defects of, 100

## F

Factors controlling wear, 134

Feldspar, 236

Felt polishers, 25, 43

Ferrous exalate, 17, 25

Fieuzal glasses, 3

Filing glass, 38

Filling engraved lines, 281

Filtrays glass, 3

Fire grates as tools, 17

Fixed tool post working, 58, 72, 73, 120, 132

Floccules, 233

Fluorite, 24, 26, 235, 236  
 best directions for polishing, 235, 246

Fluorite, colour of, 245  
 for ultra-violet achromats, 245  
 hardness of, 246  
 methods of working, 246  
 sensitivity to temperature, 246  
 ultra-violet transmission of, 245

Fluorspar (see Fluorite)

Focal length related to power, 101

Fontainebleau sands, 17

Forming fabric polishers, 43

Foucault's prism, 242  
 test, 203

Franklin lenses, 113

French cement, 29  
 lathe (see Hand Lathe), 59

Frequency of light, 175

Friction, coefficient of, 168

Frictional forces, 126  
 heating of tools and work, 92

Fringes at a finite distance, 204, 205  
 infinity, 204, 206

Frontal diopters, 102  
 distance, 102

Fronto-focometer, 104

Fused bifocal lenses, 112

Fused silica (fused quartz), 2, 17, 237

## G

Gauge slips, 2  
 method of making, 221

Glan's prism, 242

Glan-Thomson prism, 239

Glass, annealing of, 226  
 birefringence of strained, 226  
 for engraving, best, 227  
 strained, effect on optical quality, 226

Glasses, 1 *et seq.*, 24  
 absorption of, 11  
 bubbles in, 12, 13  
 catalogue particulars of, 10, 11  
 coloured, 3  
 colour of, 2  
 contraction in cooling, 12  
 Crookes, 3  
 crown, 9, 11  
 defects of, 2, 11 *et seq.*  
 dispersion of, 7, 8, 11  
 Euphos, 3  
 Fieuzal, 3  
 Filtrays, 3  
 flint, 11  
 homogeneity of, 2, 11  
 varies with cooling, 11  
 manufacturing origins in France, 9  
 moulded, 12  
 nature of, 3, 11  
 optical, 2, 3 *et seq.*  
 examination of, 12 *et seq.*

Phylex, 3

Glasses, plate, 2  
 St. Gobain, 2, 277  
 refractive index of, 1, 11  
 special, 9  
 spectacle, 2  
 coloured, 3  
 isochromatic 3  
 protective, 3  
 stirring of, 11  
 strain in, 12, 16  
 types of, 11  
 ultra-violet absorbing, 3  
 uranium, 11  
 veins in, 12  
 detection of, 13  
 Glazebrook's prism, 243  
 Glues, 27 *et seq.*  
 marine, 31  
 Glycerine as cement, 268  
 Gold, metallisation with, 289  
 Goniometers, laboratory, 208, 217  
 spot, 219  
 workshop, 216  
 Grades of emeries, 18  
 Grading of abrasives by elutriation, 18  
 minutes, 18  
 Graticules, 272  
 made by evaporation, 293  
 Green's analyser, 239  
 Grinding sands, 17  
 wheels, 42, 53  
 choice of, 42  
 Grooves in polisher, effect of, 82  
 Grooving polishers, 48  
 Gum Dammar as cement for lenses, 271  
 Gypsum 232, 236

## H

Halfmoon glasses, 113  
 Hand lathe working, 59, 121, 132, 166,  
 167, spherical, 167  
 Hand working, 52, 58, 65, 114, 132, 142,  
 166, 167, 169  
 Handle, ball-pointed, 61, 65, 114, 167  
 large diameter, advantage of, 169  
 Hardness coefficients of crystals, 235  
 Heat deformation of glass, 90, 91  
 tools and polishers, 91  
 Homogeneity of abrasive paste, 68, 123  
 Humidity of abrasive, 48, 132, 165  
 Hydrofluoric acid, 279  
 nascent, 280  
 precautions in use of, 182  
 Hypermetropia, 100, 107, 108

## I

Iceland spar, 24, 225, 229, 236, 246  
 (see also Nicol Prism)  
 abrasives for, 245

Iceland spar, cleavage of, 239  
 crystal structure of, 239  
 cutting, 239, 240, 243, 244, 245  
 to axis, 244  
 polarisers of, 239 *et seq.*  
 polishing, 244, 245  
 preferred direction of, 244  
 pressure in working, 245  
 refractive index of, 241  
 roughing, 245  
 sawing, 245  
 trueing, 245  
 Impercepto lenses, 112  
 Inch, French, 105  
 Inches, specifying lens powers in, 105  
 Inclination of axis of spherical tools, 75,  
 80  
 Indices of refraction,  
 Induced rotation, 66, 126, 154  
 effect of dryness of abrasive, 67  
 Infra-red, 1  
 Instantaneous centre of rotation, 116,  
 122, 129, 135, 143, 148  
 examples of, 117  
 influence on wear, 117  
 computing position of, 129  
 for deep curves, 141  
 inclination of 144, 148, 150, 152,  
 153, 154 *et seq.*, 161  
 Institut d'Optique, 4, 13, 78, 90, 104, 158,  
 214, 291  
 Interference fringes, 176  
 at a finite distance, 205  
 at infinity, 206  
 monochromatic, 177, 180, 183  
 reflection, 179  
 seen obliquely, 180  
 table of, 190  
 transmission, 179  
 white light, 177, 180, 183  
 in thick plates, 179  
 thin plates, 177  
 of light, 175  
 tests, light sources for, 180  
 methods of viewing, 180  
 interpretation of, 180  
 temperature effects in, 91  
 Interferoscope, 205  
 Isochromatic glasses, 3  
 Isotropic substances, 225, 246

## J

Jarret's procedure for testing angles, 208  
 accuracy of, 209  
 Jasper, 24

## K

Kinematic effect, 133  
 wear, 139

Klaprothine, 25  
 Knobs, tool (see also Handles), 169  
 Kryptok lenses, 112

## L

Lathe with adjustable relative rotations,  
 78, 90, 140, 144, 148, 153, 154, 158  
 correction of blocks on, 166  
 Large surfaces, special tools and polishers  
 for, 48  
 tool knobs, use of, 169  
 Lazulite, 24, 25, 94  
 Lens, "bi", 101, 106  
 bifocal, 112  
 chromatic aberration of, 4, 6  
 cylindrical, 83, 89, 103, 262  
 deformation with heat, 91  
 focus of, 101  
 meniscus, 5, 104, 107  
 spherical aberration of, 4, 7  
 sphero-cylindrical, 107  
 Lenticular lenses, 112  
 Light, frequency of, 175  
 interference of, 175  
 monochromatic, 1  
 nature of, 174  
 sources of, for interference, 175  
 velocity of, 174  
 Lighting of optical workshops, 50  
 Local retouching, 80, 166  
 Loss of light at surfaces, 267

## M

Machine working, 52, 82  
 Macle (twin crystal), 233, 237, 238  
 Magnification, 102  
 Mallets, 29  
 Mallet stick, 78  
 Marine glue, 31  
 Massiat's Cement, 32  
 Measurement of radius of curvature, 184  
 Meehanite, 40  
 Meniscus lens, 5, 104, 107  
 aberrations of, 5  
 Mercury green line filters, 191  
 vapour lamps, 181, 197, 203, 204  
 Metallic mirrors, 93 *et seq.*, 284  
 Metallisation, by cathode sputtering, 289  
 evaporation, 289  
 of mirrors, 284 *et seq.*  
 Methylated spirit, 49  
 Mica, 232, 236  
 cleavage of, 248  
 crystal structure of, 247  
 waveplates of, 247, 248  
 Micrometers, 272  
 Milling of glass, 22

Minimum deviation, 5  
 "Minute" system of grading emeries, 18  
 Mirrors, 284  
 cellular, 288  
 metallic, 93, 284  
 technique, 93  
 metallisation of, 284 *et seq.*  
 new substances for, 288  
 types of, 288  
 Modes of movement of spherical tools,  
 141  
 Monochromatic fringes, 177, 180, 183,  
 197  
 light, 1  
 Mortar, Abich's, for crushing diamonds,  
 23  
 Mounting optical work, 92  
 Movements, machine, adjustment of, 125  
 rotary and translatory, 144 *et seq.*  
 Myopia, 100, 107, 108

## N

Needles, tracing, 274  
 Nickelled mirrors, 289  
 Nicol prism, 227, 239, 240  
 action of, 241  
 cements for, 240  
 method of cutting, 240  
 path of rays in, 241  
 quality of, 240  
 "swallow" template for cutting, 240  
 Norremberg's apparatus, 227, 234, 236,  
 237, 244

## O

Observing fringes normally, 180, 196  
 Oil cement, 27, 28  
 of turpentine, 31, 34, 37  
 -putty polishers, 47  
 Omnibus polisher, 111  
 One-piece bifocal lenses, 111  
 Optical glass, 2, 3  
 dispersion of, 7, 8, 11  
 effect of boric acid on, 3  
 manufacture of, 3-4  
 properties of, 3  
 softening of, 4  
 varieties of, 4, 11  
 works tests on, 12 *et seq.*  
 tests in the workshop, 174  
 workman, qualities of, 51  
 workshop, specification of, 50  
 Optician's cement, 27  
 prescription, 103  
 Ordinary image, 225  
 ray, 225, 233, 239, 241, 247  
 Orthal lenses, 107  
 Orthoscopic lenses, 104

- Ostwald's cement, 29  
 Out of plumbness, 67, 73, 79, 98, 129, 130, 140, 141  
 Overlap, 48, 65 *et seq.*, 73, 74, 75, 77, 132, 133, 156 *et seq.*, 165, 199  
   effect of, on direction of rotation, 66, 119, 127  
     homogeneity of abrasive, 68, 122 *et seq.*  
     instantaneous centre, 119, 122  
     quality of work, 125, 154  
     speed of rotation, 65, 120, 122  
 optimum, 68  
 symmetrical, 138  
 table of, 124  
 theoretical profile produced by, 68  
 unilateral, 138
- P
- Palladium metallisation, 289  
 Paper polishers, 24, 25, 47, 82  
   advantages of, 47, 125  
   worked dry, 47  
 Parabolisation, 197  
   testing by interference, 202  
 Paraffin wax, 34  
 Parallelogram of rotations, 150  
   velocities, 144  
 Parallel plates, testing of, 179  
   by fringes at finite distance, 204, 205  
   at infinity, 204, 206  
 Pedal lathe (see Treadle Lathe)  
   working, 59, 72  
 Periscopic lenses, 103, 106  
 Peroxide of iron, 25  
 Phylex glass, 3  
 Piezo-electric quartz plates, 238  
 Pitch and sealing-wax cement, 254  
   -cloth polishers, 46, 94  
   mallets, 146  
   polishers, 31, 33, 44, 50, 81  
     distribution of pressure on, 147  
     preparation of, 33, 44 *et seq.*  
   Swedish for polishers, 33  
   -wool polishers, 46  
 Pivot bearings, corundum, 250  
 Plane surfaces, best driving point for, 168  
   working of, 73, 150  
     on automatic lathe, 73  
     on fixed post, 73  
     on hand or treadle lathe, 74  
   tools, trueing up, 73, 124  
   parallel plates (see Parallel Plates)  
 Planning work, 95-99  
 Plano-spherical lenses, 101, 106  
 Plaster blocks, 34, 49  
   of Paris, 28, 34  
   moulding, 28, 34  
 Plastic polishers, 147  
 Plateau à caillebotter, 39  
 Plate glass, 2, 277  
   St. Gobain, uniformity of, 2  
 Platinum metallisation, 289  
 Point-image lenses, 107  
 Polarisation, 224  
   by absorption 247  
     reflection, 224  
     refraction, 225  
   circular, 225, 227  
   discovery of, 227  
   elliptical, 225, 227  
   field of, 242  
   partial, 242  
   plane, 224  
   plane of, 224, 232  
   rotatory, 232  
 Polariser, 226  
   pile of plates as, 225  
 Polarising prism (see also Nicol), 240  
   air separation, 242  
   cements for, 240  
   field of, 242  
   Foucault's 242  
   Glan's 243  
   Glazebrook's, 243  
   Rochon's, 244  
   Sénarmont's, 244  
   square ended, 240  
   Thompson, 242  
   Wollaston's, 244  
 Polishers, cloth, 25, 29, 43, 110  
   cementing of, 29  
   cut away, 80  
   distribution of pressure on, 147  
   felt, 25, 43, 110  
   for metal surfaces, 94  
   grooving of, 48  
   heating methods for, 91  
   maximum pressure on, 57  
   modifying shape by heating, 91  
   oil cement, 28  
   oil-putty, 47  
   paper, 24, 25, 47, 82  
   pitch, 31, 44, 50, 81, 88  
     -cloth, 46, 94, 99  
     concave, 44  
     convex, 45  
     flat, 45  
     -wool, 46  
   rosin and wax composite, 48  
   special for large surfaces, 48  
   taffeta and velours, 43, 94  
   waxed cloth, 46  
 Polishing cylindrical surfaces, 62, 87 *et seq.*  
   duration of, 57  
   metallic mirrors, 94  
   on cloth, 25, 53, 110

Polishing cylindrical surfaces, on felt, 25,  
 \* 43, 110  
 paper, 24, 25, 47, 53, 237  
 pitch, 26, 80, 237, 246  
 velours, 43, 245  
 position of driving pin in, 63  
 powders, 25  
 preferred direction of, in crystals, 235,  
 244, 245, 246, 249  
 rouge, 17, 25, 43, 57  
 spectacle lenses, 53, 58  
 Positions of tool and work, relative, 63,  
 69, 78, 131  
 Power of a lens, 100, 105  
 measurement of, 104  
 Precision of working, 174  
 Presbyopia, 100  
 Prescription, oculists', 103  
 Pressure, adjustment of, 82, 83, 95, 141  
 in proportion to wear, 52, 67, 83  
 maximum and minimum, 52  
 on tool, distribution of, 53, 57  
 spherical surfaces, distribution of,  
 146  
 tool for various abrasives, 53  
 optimum, 48, 51, 53, 67  
 uniformity of, 57, 140  
 Prismatic diopters, 106  
 Prisms, defined, 1  
 isosceles right angle, test of, 220  
 refraction through, 5  
 60°, tests of, 212, 220  
 working to angle, 212  
 Privileged regions of tool or work, 51, 59  
 Profiles produced by various working  
 systems, 69, 71  
 Project, a surfacing, 150  
 Proof plane, 82, 174, 180, 185, 209, 211,  
 212  
 testing shallow curves, 185  
 use in making angles, 209  
 sphere (see Test Plate)  
 Proportion of wear to pressure, 147  
 Protectors (see also Chocks), 65, 75  
 Pumice powder, 17, 24, 345  
 grading of, 24  
 stone, 24  
 Putty powder, 17, 26, 43, 95, 237  
 -oil polisher, 47  
 Pyrex glass for test plates, 185

## Q

Qualities of a good optical worker, 51  
 Quality of work better than tools, 85, 125  
 Quartz, 2, 17, 25, 229, 232, 236  
 abrasives for, 237  
 Brazilian, 236  
 crystal structure of, 236  
 determining axis of, 237

Quartz, dextrorotatory, 230, 232  
 -fluorite objectives, 245  
 for spectacle lenses, 2, 236  
 fused, 2  
 low expansion of, 2  
 laevorotatory, 230, 232, 236  
 piezo-electric plates of, 238  
 sawing of, 237  
 sensitive to temperature changes, 237  
 twin crystal in (Maclé), 233, 237, 238

## R

Radius of curvature measured by test  
 plate of different curvature, 188  
 in relation to power of a lens, 105  
 measurement of, 184  
 Ratio of wear, 119, 150  
 Recovery of used emery, 19  
 Refining abrasives, 42, 58  
 Reflection, total, 241  
 Refraction, index of, 1, 8  
 Refractive index of Canada balsam, 241  
 castor oil, 268  
 Iceland spar, 241  
 relative, 267  
 spectacle glass, 105  
 Relative positions of centres, 140  
 work and tool, 63, 69, 78, 131  
 Relieved polisher, distribution of pres-  
 sures on, 147  
 Relieving polishers, 72, 75, 80, 91, 165  
 Resins, 27  
 Resist for etching, 281  
 Retarding rotation of work, 141, 149, 160  
 Reticules, 272  
 engraved, 274  
 thread (spider web), 272  
 cementing and setting, 273  
 traced, 273  
 black varnish for, 274  
 Retouching surfaces, 80, 166  
 Right angle, direct test of, 218  
 isosceles prism, test of, 220  
 method of making, 210  
 Rochon prism, 244  
 Rock crystal (see Quartz)  
 Rock salt, abrasives for, 246  
 cleavage of, 246  
 crystal structure of, 246  
 hygroscopic nature of, 246  
 lubricants for working, 246  
 method of storage of, 246, 247  
 polishing of, 246  
 protection of surfaces, 246  
 Rose à polir, 17, 26  
 Rosin, 27, 48, 49  
 Rotary movements, 114, 141, 160

- Rotation, induced, 66, 126, 154  
   instantaneous centre of, 116, 122, 141,  
     143, 144, 148, 149  
   examples, 157  
   retarded, 66, 149, 154, 158, 160  
   variation with position of work, 65, 126  
 Rotatory surfacing, 69, 121  
 Rotten stone, 24  
 Rouge, English, 25  
   French, 25  
   mean grain size of, 57  
   polishing, 17, 25, 43, 47  
   preparation of, 25  
   test for tools, 223  
 Roughing, 17, 38  
   by filing, 38  
 Rubber cement, 32  
 Ruby, 24, 26, 236, 250  
 Rupert's drops, 12
- S
- Saccharimeter, 232, 234  
 Sands, siliceous, for grinding, 17  
 Sandstone grit, 17, 38  
 Sapphire, 250  
 Saw for glass, 35  
 Scouring ("caillebottage"), 39, 53, 55,  
   63, 77, 79, 91  
   plate, 39, 55, 79  
 Scratches, 40  
   effect of pressure on, 57  
   precautions against, 41, 58  
 Searchlight mirrors, 203  
 Seccotine, 27  
 Sénarmont prism, 244  
 Serbat's cement, 28  
 Shellac cement, 30, 49  
   varnish, 30, 35  
 Sibor glass for test plates, 185  
 Silica, fused, 237  
 Silice alumineuse, 26  
 Silvering, Brashear process, 284  
   cathodic, 289  
   coppering of, 286  
   mercury amalgam, 284  
   partial, 284  
   polishing of, 286  
   preparing glass for, 285  
   solutions, 285  
   technique, 286  
   transparent to U.V., 289  
 Size of image, 102  
   piece to be surfaced, 133  
 Sleeks, 15  
 Slips, use of with test plates, 192  
 Slitting discs, 22, 35  
   charging of, 35  
   Slitting saws, 35  
   Smoothing, 24, 41, 56, 58, 75, 98, 174  
     metallic mirrors, 94  
     parabolic mirrors, 197  
   Sodium light, 1  
     silicate cements (see Cements, Water-  
       glass)  
   Spanish white cement, 29  
     used for polishers, 44  
   Spectacle glasses, 2 *et seq.*  
     lenses, 53, 58, 100 *et seq.*  
     edging machine for, 261  
     grooving and chamfering, 261  
     power of, 100, 105  
     in inches, 105  
     surfacing of, 110  
     types of, 106 *et seq.*  
   Spectra, 1  
   Spectrum lines, standard, 1  
   Speed of rotation, 85, 154, 158  
     and wetness of abrasive, 66, 132  
     overlap, 65, 67, 120  
     effect of varying, 67, 164  
   Spherical aberrations, 4  
     surface, absence of translatory move-  
       ment on, 74  
     distribution of wear on, 74, 75, 76,  
       141  
     edge-off effect on, 61  
     large blocks of, 75  
     overlaps with, 75  
     working on automatic lathe, 61, 75  
       fixed post, 65, 74  
       optimum angle of axis, 76  
       pedal lathe, 76  
     tools, tests of, 222  
       correction of 79  
   Sphero-cylindrical lenses, 107  
   Spherometer for spectacle lenses, 101,  
     104  
   Spider webs, 272  
   Spirits of wine, 49  
   Sponges, 49  
   Spot goniometer, 219  
   Squint, 100  
   Stack of discs ("carrotte"), 54  
   Stanhope test plates, 193  
   Starch paste, 27, 47  
   Steel, polishing of, 93  
   Stigmal lenses, 107  
   St. Gobain plate glass, 2  
     for engraving, 277  
   Strabismus, 100  
   Straight-edge test by autocollimation, 222  
   Strain, detection of, 227, 228  
     in glass, 12  
     cutting lenses in relation to, 16  
     test of, 16  
     -viewer, 227  
   Strained glass, birefringence of, 226

Sugar solutions, rotatory polarisation in, 232  
 Surface errors, unit of measurement, 174  
 Surfacing, 50, 51  
   cylindrical, 83 *et seq.*  
   development of a project for, 133  
   fundamental principles, 51  
   of slightly curved surfaces, 133  
   of spectacle lenses, 110  
   working out a project for, 95, 154  
 Systems of equal rotation, 128  
   even wear, 51, 74, 75, 128  
   surfacing, 51, 120

## T

## Tables:

angle of prism and deviation, 106  
 distribution of wear on discs, 137  
 mean diameter of abrasives, 57  
   wear, 148  
 number of fringes for differing radius, 190  
 optimum inclination of axis of work, 76  
 overlaps, 68  
   pressures on tools with different abrasives, 53  
 overlaps giving best mixture of abrasive pastes, 124  
 polishing times, 58  
 prismatic diopters and deviations, 106  
 Taffeta polishers, 43, 94, 245  
 Talc, 236  
 "Telegic" lenses, 112  
 Telescope lens working, 72  
   mirrors, parabolisation of, 197  
 Temperature of workshop, 50  
 Temper in glass (see Strain)  
 Templates, 184, 222  
 Tests by fringes at a finite distance, 204, 205  
   at infinity, 204, 206  
   effects of warmth on, 91  
   Foucault's, 203  
   of angles, Jarret's method, 208  
   test-plate methods, 210  
     autocollimation, 214  
     parallel plates, 204  
     searchlight mirrors, 204  
     surfaces, 174 *et seq.*  
   optical workshop, 174 *et seq.*  
   rouge, for tools, 223  
 Test plates, 174, 184  
   aspherical, 196  
   correction of, 184  
   cylindrical, 195  
   earliest use of, 184  
   effect of separating, 186  
   examining small lenses with, 194

Test plates, how to remove, 183  
   material for, 2, 185  
   of deep curvature, 189  
     shallow, 187  
   shape of, 193  
   Stanhope, 193  
   thickness of, 185  
   toric, 195  
   use of, 180 *et seq.*  
     of different curvatures, 188  
     separators with, 187, 192  
     working to, 177, 184  
 Thalweg, 167  
 Theorem of wear, Fundamental, 128  
   second, 130  
   third, 143  
   fourth, 148  
   fifth, 150  
 Theory of surfacing, 114 *et seq.*  
 Thermal deformations, 90  
 Thompson prism, 242  
 Tilt of tool, 67  
 Tool handles, ball-pointed, 61, 65, 114, 167  
   fixed or screwed, 60, 76, 167  
   rotating, 167  
 Tools, alloy for making, 40  
   blocking, 38  
   cone mounting for, 37  
   difference in radii of a pair, 45  
   embedding of emery in, 38, 41  
   flexure of, 57  
   for slitting or sawing, 35  
   grooving of, 48  
   material for, 40  
   mounting of, 38  
   pierced for moistening abrasive, 48, 122  
   pressure on, 52, 57, 84  
   privileged regions on, 123  
   roughing, 17, 38  
   size of, 72  
   slitting, 35  
   smoothing, 40  
   special for large surfaces, 48  
   tests of, 221  
     by spaces (daylight), 221  
   thermal deformations of, 90  
   thickness of, 41  
   trueing, 38, 40  
     -up of, 41  
       plane, 73  
   webbed, 48, 57  
 Topaz, 236  
   lenses, 72, 89, 108  
 Toric test-plates, 195  
   tools, 54, 56, 90  
 Torus, 108  
 Tourmaline, 231, 247  
   axis of, 247  
   nature of, 247  
   polarises by absorption, 247

- Tourmaline, surfacing technique for, 247  
 tongs, 231, 247  
 Traced reticules, 274  
 Tracelet for engraving, 278  
 Tracing needles, 274  
 Track of driving pin, 155, 162, 165  
 tool, 125  
 eccentricity of, 138  
 Translatory movements in surfacing, 69,  
 114, 120, 131, 160  
 Treadle on hand lathe working, 74, 76,  
 77, 121, 132, 167  
 Trifocal lenses, 110  
 Tripoli, 17, 25, 47, 237  
 grain size of, 57  
 preparation of, 25  
 Trueing, 22, 38, 40, 54, 98  
 a stack of small discs, 54  
 by milling, 54  
 metallic mirrors, 93  
 -up tools, 73, 79, 147, 153, 156  
 with grinding wheels, 42, 53  
 Turkey stone, 24, 94  
 Turning-off the edge (edge off), 60, 73,  
 133, 169  
 Turpentine as a cement, 30, 268  
 oil of, 31  
 preparation of, 30  
 Venice, 27, 30  
 Twin crystal (Macle), 233, 237, 238  
 tests for, 234  
 "Two-fo" lenses, 112
- U
- Ultra-violet light, 1  
 absorbing glasses, 3  
 Uncementing lenses, 271  
 Uniaxial crystals, 232, 233  
 Unibifocal lenses, 111  
 Uniformity of pressure, 140  
 wear, 52, 118
- V
- Vacuoles, 233  
 Valseurs, 158, 160 *et seq.*  
 choice of, 163  
 effect of on length of track, 165  
 left-handed, 161, 164  
 right-handed, 161, 164, 165  
 use for correcting deep curves, 165  
 Varnish for etching, 281  
 Veils in crystals, 234
- Veins in glass, 12  
 "flaring" for, 13  
 location, 13, 15  
 by Arnulf's method, 13  
 Velocity of tools, effect on wear, 132  
 Velours polishers, 43, 245  
 Ventilation of optical workshops, 50  
 Vinegar for cleaning, 49  
 Vocabulary of technical terms, xi
- W
- Warm blocks and polishers, work with,  
 75, 155  
 Water-glass cements, 32  
 -proof cements, 31  
 Wavelength, 175  
 Waveplates ( $\frac{1}{4}$ , etc.), 247  
 testing of, 248  
 Wax cement, 27  
 resist for etching, 282  
 yellow, 27  
 Waxed cloth polishers, 46  
 Wear, calculation of, 134, 138  
 dependent on path, 132  
 distribution of, 117, 134, 137, 156  
 kinematic, 139  
 mean, table of, 148  
 relative to pressure, 52, 67, 84  
 uniformity of, 51, 70  
 variation with overlap, 70  
 pressure, 52, 67, 83  
 (see also Theorems of Wear)  
 Web frame for spider's web, 273  
 "Wet", 41  
 Whetstone, powdered, 24  
 White light, composition of, 1  
 fringes, 183  
 spectacle glass, 2  
 etching properties of, 277  
 Woolaston's prism, 244  
 Wool and pitch polishers, 46  
 Working out a surfacing project, 154  
 to colours, 177  
 test plate, 177  
 Workman, qualities required in, 51  
 Work of rotation, 69, 70  
 translation, 69, 70  
 Workshop goniometers, 216  
 optical, specification for, 50  
 tests, optical, 174 *et seq.*
- Z
- Zylol, gum dammar in, 271

















