

UNIVERSAL
LIBRARY

OU_164228

UNIVERSAL
LIBRARY

OSMANIA UNIVERSITY LIBRARY

Call No. 575/C 88C Accession No. 33820

Author: Crampton. H.E.

Title: *Coming and evolution of life.*

This book should be returned on or before the date last marked below. 1934

THE COMING AND EVOLUTION OF LIFE

How Living Things Have Come To Be As They Are



By HENRY EDWARD CRAMPTON, PH. D., Sc. D.

PROFESSOR OF ZOOLOGY, BARNARD COLLEGE, COLUMBIA UNIVERSITY



Highlights of Modern Knowledge



BIOLOGY



THE UNIVERSITY SOCIETY
INCORPORATED
NEW YORK

COPYRIGHT, 1911, BY
THE UNIVERSITY SOCIETY
INCORPORATED

First Trade Edition 1934

Manufactured in the U. S. A.

CONTENTS

CHAPTER	PAGE
I THE NATURE OF LIFE AND OF LIVING THINGS	1
The Meaning, Aim, and Methods of Science—Contrast of Living and Lifeless Objects—Vital Properties of Organisms Due to Conditions—Qualities of the Organism—Adaptation, a Characteristic of All Organisms—The Nature and Functions of an Organism—The Eight Functions of All Animals—Animal Tissues—The Cell the Biological Unit—Ultimate Constituents of Living Matter—How Living Matter Does Its Work	
II THE ORIGIN OF LIVING MATTER	13
III THE MEANING OF EVOLUTION	15
The Reality of Universal Natural Change—Evolution Everywhere—Evolution, a Science—Errors Concerning Evolution—Evolution and Design—Evolution and Philosophy—Evolution and Religion—Outline of the Discussion	
IV THE HISTORY OF THE CONCEPTS OF EVOLUTION	25
Growth of the Evolutionary Idea—The Ideas of the Greeks—Aristotle as a Naturalist—Beliefs of the Early Christian Fathers—The Middle Ages—The Modern Era, Linnaeus to Lamarck—The Significant Work of Charles Darwin	
V THE INTERPRETATION OF ANIMAL STRUCTURE	37
The Reasons for Animal Resemblances—Lesser and Larger Groups of Animals—Further Classifications—The Interpretations of Comparative Anatomy—The Evidence from Vertebrate Brains—What the Skulls of the Mammals Show—Similar Evidence from the Limbs of Animals—The Significance of Vestigial Structures—Vestigial Structures in the Human Organism—Summary	
VI DEVELOPMENT AND EVOLUTION	53
The Fascinating Task of Embryology—Only Organisms Can Change—Early Ideas Regarding Development—	

CHAPTER	PAGE
Embryology of the Frog—The Significance of Mammalian Embryology—Other Illustrations of Recapitulation	
VII THE HISTORY OF FOSSIL ANIMALS	66
The Nature and Meaning of Fossils—Older Views Regarding Fossils—The Modern Interpretation—The Unique Value of Fossil Evidence—Arranging Fossils in Their Time-Order—Conclusions from the Facts	
VIII THE NATURAL PROCESSES OF EVOLUTION	76
The Process of Evolution Everywhere the Same—Adaptation a Universal Feature—Variation and Heredity—Buffon, Erasmus Darwin, and Lamarck—The Invaluable Work of Charles Darwin—How Offspring Differ—Overproduction and Survival of the Fittest—Inheritance—The Facts of Artificial Selection—Sexual Selection—Modern Investigation of the Factors of Evolution—The Physical Basis of Heredity—The Relative Values of Heredity and Environment	
SUGGESTIONS FOR FURTHER READING	95
GLOSSARY	97
INDEX	99

THE COMING
AND
EVOLUTION OF LIFE

*How Living Things Have Come to Be
As They Are*

BY HENRY EDWARD CRAMPTON, PH.D., SC.D.
PROFESSOR OF ZOOLOGY, BARNARD COLLEGE
COLUMBIA UNIVERSITY

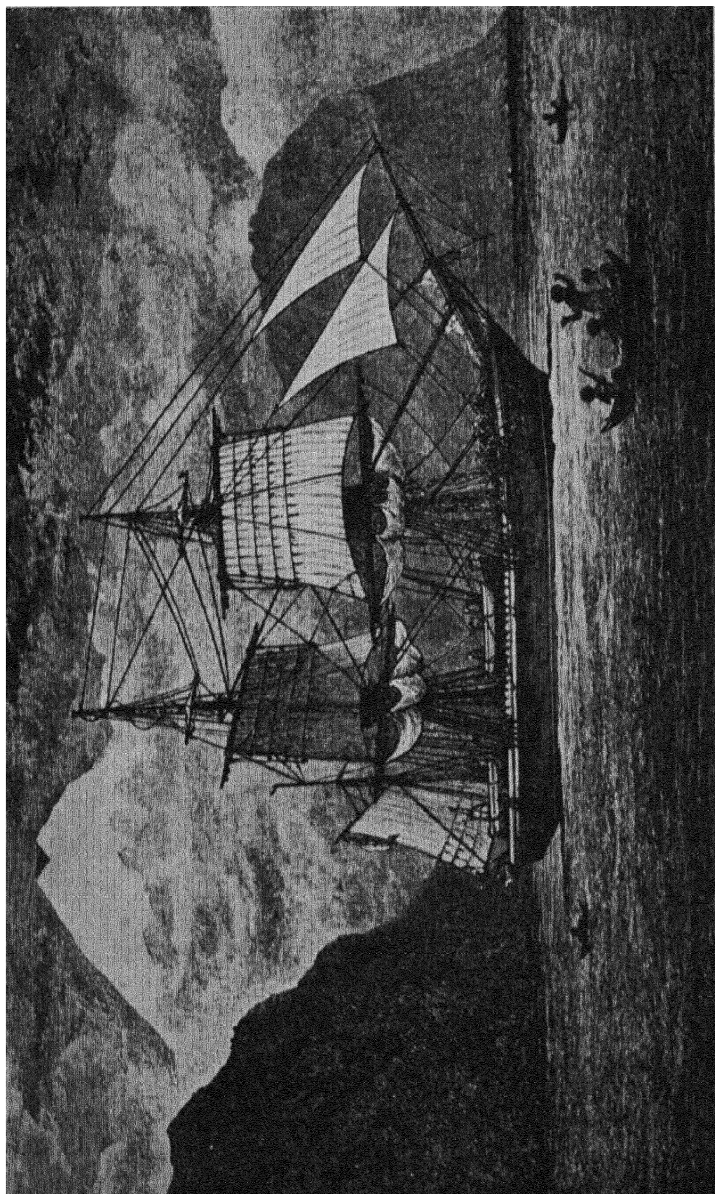

THE BEAGLE IN THE STRAITS OF MAGELLAN

Mount Sarmiento in the distance

From an old engraving

CHAPTER 1

THE NATURE OF LIFE AND OF LIVING THINGS

SINCE the human being became endowed with the powers of thought, no subjects have commanded more interest than those which are concerned with life and its manifestations, and with the peculiar qualities of living things that distinguish them from lifeless things. The organic world comprises a rich array of plants and animals which are interesting enough on their own merits and well repay the closest study. But these matters become all the more engrossing by virtue of the inclusion of humanity itself within the realm of living nature. It is true that in the days before science established its great fundamental principles, the human being was regarded as more or less independent and apart from all other creatures; but with increasing knowledge it has become ever more apparent that there are manifold likenesses and uniformities which characterize *all* living things, and that even our own kind is an integral part of animate nature.

In these pages we are to deal with some of the basic qualities of living things and with the scientific interpretation of their origins. And although it may not always be evident, the outcome will show that whatever we may learn about the general features of animals will be valuable for a more adequate understanding of human nature and human history. We shall devote our attention largely to animals and to the science of zoology which deals with these living creatures. But many things in the nature of plants and animals agree so closely that the general principles of *zoology* and *botany* are identical. For this reason these two departments of science constitute the inclusive subject of *biology*, which may, therefore, be defined as *the study of the qualities and activities of all living things as well as their relations to the world in which they live.*

2 THE COMING AND EVOLUTION OF LIFE

THE MEANING, AIM, AND METHODS OF SCIENCE

The development of human knowledge has been characterized by a certain definite procedure termed scientific method, which is indispensable in order that truth may be established; and it is well to understand at the beginning of our task what science means. *Science is organized knowledge.* It commences with the assembly of information in the way of observed and verified fact. Mere information, however, is no more science than are piles of bricks and girders an edifice. The next essential step is to bring the data into their proper classification or relation, and it is an interesting fact that the progress of human knowledge has been accomplished less by the discovery of new items than by the proper assembly of information so commonplace that it is accepted without interest or question, thus making apparent the significance of the obvious. The third step in science is to express the meaning of the established and ordered data in some simple statement—a so-called principle, or law, of nature. Conservation of energy, the formula of gravitation, and the principles of evolution are examples of such concise statements of the meanings of the classes of facts with which physics and biology are severally concerned. They have the value which inheres in a consistent description of nature's relations and workings; and as such they possess a dynamic power as well. The principles of mechanics guide the work of the engineer, knowledge of physiology directs the efforts of the physician, and what we know of the biological nature of mankind is available, though not always availed of, for the social control of human destinies.

The realm of science is co-extensive with the knowable world, and so far as its canons are observed it gives us some understanding of that world. Devotees of science, familiar with the history of knowledge, fully understand that the truths of science are final only for the time; with the discovery of new facts, and with an improved analysis, a corrected statement of nature's meaning must be formulated. Such are the aims, the methods, and the essential meaning of science.

All things in our universe fall into one of two primary classes; they are alive or they are not. Consequently our organized

knowledge divides into the *biological science* concerned with the former and the *physical sciences* dealing with all of the rest. Even unconsciously we habitually assign a new object of experience to the one or to the other of these great categories. Conscious effort to discover why we do so makes it plain that we recognize fundamental differences in the *properties* and *abilities* of the two kinds of things. A frog moves about, feeds and grows, and multiplies after its kind, whereas a stone can perform none of these activities. The former is composed of peculiarly complex materials by virtue of which it possesses a whole series of capabilities which the latter lacks because its substance is simple and therefore inert. So fundamental is the distinction in question that we are prone to ascribe to the things of the living world an intangible attribute in the way of an activating power, conceived as something separate from the actual substances of which they are composed.

CONTRAST OF LIVING AND LIFELESS OBJECTS

It may seem absurd to question the correctness of such views. And yet only a brief consideration of facts known to everyone discovers certain likenesses which living and lifeless things exhibit; and the discovery aids materially in reaching a true understanding of life because it discloses the actual nature of the differences which seem so absolute. Obviously the two kinds of objects are similar in their behavior according to the laws of all matter whatsoever, such as gravitation and the like, because all are material things. But the fact of overwhelming significance is that the ultimate constituents of living things are chemicals actually derived from the realm of the lifeless. Nothing in human experience is more trite. Daily we replenish our bodies by eating food and drinking water which are devoid of life; a growing plant likewise draws from the soil and the air and the water the carbon dioxide and the simple chemicals which are inert in themselves but which become so combined as to be incorporated into the structure of the living organism.

All of the material elements and all of the powers of living things come to them from without. And as a consequence of the performance of vital acts the complex chemicals of the organic body break up, lose their original qualities, and eventu-

4 THE COMING AND EVOLUTION OF LIFE

ally pass back to the inorganic world whence they came, while their inherent fund of energy is expended in the dynamic operations which collectively constitute the whole life of the living thing.

Clearly, then, there is no impassable barrier between the living and the lifeless, however separated they may seem to be. An animal or a plant is only a temporary aggregation of materials and energies whose ceaseless change in every part is difficult to realize in view of the seeming constancy of the whole object. Huxley has likened an organism to a flame or a fountain or a whirlpool, each of which appears to the eye to be a persisting individual thing, and yet its components are never identical even in successive seconds. The gas coming through the tube to the burner is certainly not flame, but its particles may be incited to violent agitation by the application of a lighted match; then, as they enter into combination with oxygen to become water vapor and carbon dioxide, they glow and emit heat. The jet of the fountain would not exist unless its drops of water were constantly replaced by newcomers as fast as they fall to the basin.

VITAL PROPERTIES OF ORGANISMS DUE TO CONDITIONS

If, now, all living creatures derive their substances from the dead world, and their powers are the transformed energies which come in some way from the same outer realm, it becomes apparent that the real distinctions between the two divisions of things cannot be one of their ultimate materials. What, then, is the reason for the difference? There seems to be no escape from the conclusion that the vital properties of organisms are due to the *condition* in which their materials exist for the time, and that they are not the manifestations of the presence and action of a separate entity in the way of a so-called vital principle.*

We are to delve more deeply into this subject in a more concrete way at a later point, but it is helpful at the outset to grasp something of the significance of the facts which prove that the living *condition* is really a state of being. Similarly, heat was

* Vital principle, an immaterial force, to which when present in organized matter the functions peculiar to living beings have been ascribed.

conceived by the physicists of a century ago as the product of a separate entity which they called "caloric," but now we know that a warm object differs from the same thing when it is cold only in a condition of more violent agitation of its finer particles. Likewise "health" does not exist by itself, but it is a state of being or condition. And no one has ever seen "redness" as such save as a quality of a red flower or red fabric or of another concrete object.

From such considerations we are able to form a truer conception of the nature of living things and of the real basis for their contrasts with lifeless objects. They are characterized by a series of activities which are manifested by virtue of the elaborate constitution of their physical substances; the components of the latter are not in any way restricted to the living world, but they are in fact dead chemicals which have come to be associated for a time in definite and peculiar combinations. Hence our subject of biology is to be defined as *the study of matter in the living condition*, with the explicit understanding that the elements of the matter in question belong to the realm of lifeless substances with which the physical sciences are concerned.

QUALITIES OF THE ORGANISM

Drawing upon our knowledge of familiar animals, we are next to consider some of their common qualities whose analysis carries us farther in our inquiry into the nature of living things. A living thing is called an *organism* and the word connotes at least two essential qualities: (1) a condition of complexity above that displayed by an inanimate object, and (2) a degree of definiteness in make-up which is also distinctive in the same comparison. Even in such casual respects as size and consistency, the contrasts are evident. Water may be a molecule, or a drop, or a lake; water may be a fluid, or a gas, or a solid, according to its temperature. But organisms range within restricted limits in respect to size, and their living constituents are never anything else but gelatinous in texture, somewhat fluid and somewhat solid. Above all, organisms agree in certain definitenesses and complexities of the chemistry of their essential living materials, which are so much alike that they constitute a well demarcated class of substances named *proto-*

6 THE COMING AND EVOLUTION OF LIFE

plasm. It seems incredible that this could be true when we contemplate the varied representatives of the animal array from ameba and the jellyfish to worms and insects and vertebrates, and the manifold examples of the plant series from seaweeds to ferns and higher forms which produce flowers. But the fact remains and it is one of the most fundamental among the unities existing throughout the whole organic world.

ADAPTATION—A CHARACTERISTIC OF ALL ORGANISMS

Constructed in various ways, as they are, all animals agree in at least one outstanding feature, namely, in their architectural adjustments to the circumstances they must meet in their lives. The cat is organized to live on land and to find its prey among other terrestrial creatures. A fish possesses gills instead of lungs, and hence it is adjusted to life in the water. A jellyfish presents yet another form of organization which enables it to meet in still other ways the conditions obtaining in the ocean. Like the general chemistry of protoplasm, some adequate degree of *adaptation* to environment is a universal characteristic of all organisms; familiar though this is, it is one of the most significant features of living objects, and we shall have occasion to reconsider it at many points in the later discussions.

THE NATURE AND FUNCTIONS OF AN ORGANISM

Proceeding with a general analysis of the animal, biology views it as a composite of certain kinds of parts, called the organic systems, and it also treats the life of the whole individual as the sum total of the activities of these several components. The life of a cat is the combined work of the muscles by which it moves, of the lungs which provide the requisite supplies of oxygen, of the heart and blood vessels which distribute the oxygen and the new supplies of digested foods to all the parts of the body. Thus an *organism* is structurally the sum total of its constituent *organs*, and its life as a whole is the combined product of the diverse activities which the organs are severally constituted to perform. *Each organ and system displays the same quality of adaptation in its make-up which characterizes the creature as a whole*, and the several kinds of apparatus are inter-

adjusted mutually in entire conformity with the same general principle.

THE EIGHT FUNCTIONS OF ALL ANIMALS

Another striking point is that all animals agree in performing the same eight functions, no more and no less; and this is another of the zoological unities which calls for full recognition. Their material make-up may be simple or complex, but the life of even the highest among them comprises no more kinds of organic activity than we find in the case of the most elementary.

1.—They all replenish their bodies by something of an *alimentary* apparatus.

2.—They *respire* by taking in oxygen and giving off gas-wastes of vital activity.

3.—They distribute the supplies of food and oxygen, whether this necessary *circulation* be accomplished by mere diffusion or by an elaborate series of blood vessels.

4.—They *excrete* when they throw off the ash-wastes of their protoplasmic combustion.

5.—They exhibit *motion* and *locomotion* to some extent.

6.—They have certain material parts which serve to *protect* and *support*.

7.—Their accomplishments to the end of individual maintenance include also the workings of especially delicate components which *co-ordinate* the efforts of other systems and at the same time, through *sensation*, effectively relate the organism to the environment with which it is so intimately interlocked.

8.—All animals multiply, or *reproduce*, as they must if their kinds are to persist in a world where accidents decimate the numbers of every species, and where they are forced to engage in an unremitting struggle to find and kill some other creature for food and to evade one foe after another—a struggle which invariably ends with death as the penalty for failure in some essential respect.

ANIMAL TISSUES

Taking the next step in the analysis, every organ itself may be resolved into components in the way of its *tissues*. For example, the leg of a frog is a unitary part of the whole body which accomplishes locomotion. It is composed of the diverse

8 THE COMING AND EVOLUTION OF LIFE

elements of the outer skin, contractile muscles within, the indispensable bone which confers rigidity, as well as the intrinsic * nerves and blood vessels of the limb. These tissues differ structurally and therefore functionally, and they are adaptively inter-related so as to present in detail what the organs and the whole animal itself display. Thus we come to understand the whole animal as the sum total of its component tissues, and its life as the combined work of these constituents.

THE CELL THE BIOLOGICAL UNIT

But every tissue of every animal may be further analyzed into finer elements. These are called *cells*, from the Latin *cella*, meaning a small room, because the first ones to be observed with the earliest crude microscopes happened to be plant cells and the dead walls of plant cells conspicuously divide the plant tissue into *cellae*. Although the term is not properly applicable, yet for historical reasons it is universally employed for the units which make up all of the tissues of all of the organs of living things, with the understanding that it refers to the elementary masses of living matter or protoplasm which may or may not possess a dead encasement. Tissues differ among themselves by virtue of the diversities exhibited by their cells, and their essential work varies because their cells possess different abilities. The point of greatest importance is that a frog or any other familiar animal comprises nothing material other than its cells, and that its life as a whole includes nothing which does not begin with an act on the part of a cell. What its cells are determines what a human being or a cat or an oak tree is, and what these ultimate units do makes up the life of the one or the other, just as an army is only an aggregate of individual soldiers whose combined efforts become the operations of the larger body.

Thus our inquiry into the nature of a living thing like a frog or a human being is focused upon the vital units, the cells, for there is nothing else to be found in the organic world. Every cell of an animal or of a plant is a minute body of protoplasm, called the *cytoplasm*, containing a distinct element, the *nucleus*, which is also composed of protoplasm and which acts as the

* Intrinsic (in anatomy), included wholly within an organ or limb; opposed to *extrinsic*.

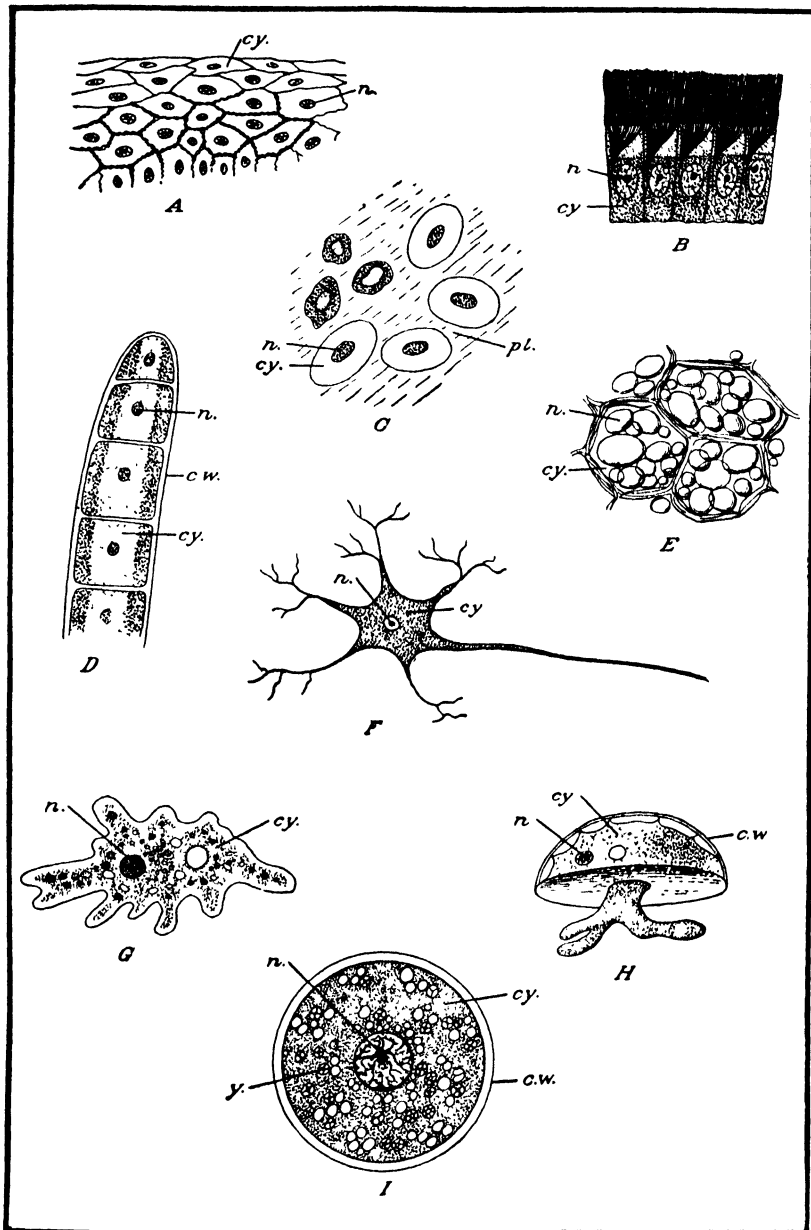

Fig. 1—TYPES OF CELLS

A, surface or epithelial cells; *B*, ciliated epithelium; *C*, three white and four red blood corpuscles of frog; *D*, cells of water plant (*Elodea*); *E*, potato cells; *F*, nerve cell. *G*, unicellular animal (*Amoeba*); *H*, unicellular animal with shell (*Arcella*); *I*, egg-cell. *n*, nucleus; *cy*, cytoplasm; *c.w.*, cell wall, membrane, or shell; *y*, yolk spheres

10 THE COMING AND EVOLUTION OF LIFE

controlling dynamic center of the cell. Cells differ greatly in their individual forms and in the ways in which they are arranged to constitute the tissues. They may be devoid of cell walls or they may produce various kinds of dead outer supports (intercellular matrices). Their cytoplasmic bodies may be particularly sensitive, as in the nerve cell, or so organized as to be contractile as in the muscle cell. Furthermore, the living substance may form various kinds of dead products within the confines of the unit, like starch in the plant-cell or yolk within the egg. But however varied cells may be, they agree throughout the whole living world in their nucleated, protoplasmic natures.

The foregoing discussion gives us the conception of the cell as the biological unit of the first order in the *analytical* sense. When animals and plants are arrayed according to their degrees of complexity, it transpires that the most elementary among them are only single-nucleated bodies, and thus the cell proves to be the biological unit in the *comparative* sense as well. If the life-history of any complicated organism is followed backward to its inception, the starting point proves to be a single cell—nothing more and nothing less; and hence, finally, the cell is the biological unit in the *developmental* sense. From all of these considerations it is clearly evident that the problems of life and of living matter must concentrate on the nature and behavior of protoplasm—the physical basis of all vital manifestations throughout the organic world.

ULTIMATE CONSTITUENTS OF LIVING MATTER

Protoplasm is a complex mixture of the commonest chemicals known to science. Its jelly-like, or colloidal, consistency is due to the large amount of ordinary water universally present, and which is primarily responsible for the ease with which physical and chemical transformations take place when it does its work. The most important formed constituent is an elaborate kind of substance called the *protein* which is a compound of carbon, hydrogen, oxygen, nitrogen, sulphur, and phosphorus—the last being more universal in the proteins of the nuclei than in the cytoplasm. Each of these ingredients, by itself, is exactly the same in substance and in property as it was

in the dead world from which it came. Other compounds are the less complex *carbohydrates*, such as sugar and starch, consisting of carbon, hydrogen, and oxygen with the latter two in the same two-to-one proportion in which they occur in water; and the *lipoids*, or fats, which also consist of carbon, hydrogen, and oxygen combined in other relative amounts. Along with these materials, protoplasm contains simple mineral combinations of sodium, calcium, iron, potassium, magnesium, and chlorine—all of which again are among the commonest chemical elements known. Thus the list of the ultimate material constituents of living matter contains no item which is confined to the organic world, and it is this impressive fact which brings into clearer relief that *it is the condition in which they are combined that confers upon the more or less elaborate mixture the distinctive powers which the elements do not possess individually.*

Science employs the same principle in interpreting the properties of protoplasm in terms of the combined potencies of its elements as it does in the case of lifeless chemicals. Taken singly, hydrogen and oxygen do not possess the characters of the compound water, but in some way the latter is the natural product of the former when the elements are combined in the definite proportions of two to one. Hydrogen and oxygen and carbon come into a union as $C_6H_{10}O_5$ to be starch, whose whole molecule has still other and more varied properties. In the same way the attributes of the most elaborate compounds, the proteins, are regarded as the products of the qualities contributed by their simpler components; the protein molecule is much more complex and it comprises more kinds of atoms, but these circumstances serve only to emphasize the fact that such highly organized substances gain their distinguishing powers by their condition of combination and not by the addition of an intangible abstraction.

HOW LIVING MATTER DOES ITS WORK

The final aspect of living matter is one of the most interesting which science has discovered, namely, the ultimate nature of its workings. What is deemed the most important property arising out of the structure of protoplasm is the dual process of "waste

12 THE COMING AND EVOLUTION OF LIFE

and repair" called *metabolism*, which has no counterpart in the inorganic world. By virtue of its physical and chemical conditions, living matter is able to assimilate lifeless increments into its own kind; this constructive process is called *anabolism*; for the same reasons living matter responds to the call for its action when it uses up its substance and converts its energies into elementary work in a breaking down process called *katabolism*.

These are the fundamental changes that underlie the actions of all of the varied cells, of tissues, of organs, and hence of entire living things. When the substance of a cell is incited to do its work, the constituents of its molecules break away from one another and enter into stable combinations of lower grade. Thus hydrogen atoms join with oxygen atoms to form water, carbon atoms link up with oxygen atoms to become carbon dioxide, and the other elements behave likewise. In brief, the materials of protoplasm are oxidized, after a manner which is essentially the same in the oxidation of lifeless substances. And co-incidentally, the chemical potential energy of the protoplasmic molecule changes its character so as to manifest itself as the element of a vital act. Hence the inevitable outcome of protoplasmic accomplishment is protoplasmic destruction; *every act of life is performed at the cost of the materials and energies concerned in the performance of the act*. This is the biological paradox. Realizing its truth, we come to understand more of the details of the ceaseless interchanges of substance and energy between the living and lifeless worlds, as well as the further reasons for the manifold inter-relations between organisms and their surroundings.

CHAPTER II

THE ORIGIN OF LIVING MATTER

WE COME now to the engrossing problem of the origin of living matter. In our present experience, protoplasm comes into existence only through the assimilative activity of other protoplasm, just as all cells come by division from pre-existing cells, and just as all organisms are the natural products of their parental types. In the earliest centuries of biological speculation, it was supposed that organisms arose naturally by *spontaneous generation*. With the development of the microscope, however, minute germs of living things were found to be the beginnings of what had been supposed to arise in such a way. It required the most careful methods of the eighteenth century to demonstrate that when the air and water and soil were effectually sterilized, no forms of organic life made their appearance. And while it is notably difficult to prove a negative, biological science is confident that under present natural conditions living things are not now produced spontaneously from lifeless constituents.

An interesting suggestion put forward a century ago was that life came to the earth from outside as an accompaniment of matter falling from stellar space. If this were true, then the question as to the origin of life is relegated to a more remote place and to realms that are not known as concretely as is the world. Furthermore, the conditions under which living forms now exist on the earth are not known to be duplicated on the planets and stars, and hence it is not probable that the germinal beginnings of the organic series were introduced from outside the earth.

While no claim is made that its decision is final, biology adopts the naturalistic view regarding the coming into existence of the first protoplasm from inorganic constituents. This critical episode must have taken place when conditions were different

14 THE COMING AND EVOLUTION OF LIFE

from what they now are, else its like might be observed today. Much of the story of the evolution of the earth itself has been deciphered and recorded in terms of the same physical and chemical changes which go forward now. It is not only possible but also scientifically probable that such forces brought about the formation of material compounds of ever-increasing complexity until at length living matter itself came into existence. It is by no means a casual fact that protoplasm consists of the commonest chemical elements of the known universe, for these would be the ones most likely to be involved in the progressive development of compounds at the bygone time when the earth's conditions were favorable for such a process.

The unity of the whole world of matter and energy, and the incessant interchanges going on between its organic and inorganic divisions, are the fundamental reasons for a belief in the natural origin of the first substances endowed with life as the inherent accompaniment of their newly established complexities. Furthermore, the chemist has learned to construct a whole series of compounds which were formerly believed to be peculiar to organisms as products of a vital force distinct and apart from the energies manifested by lifeless objects. The progress of biochemistry—the chemistry of living organisms—has been so great that many believe it will sometime be possible to combine lifeless constituents into still more complex substances approaching protoplasm, and that protoplasm itself may sometime be made artificially.

In this chapter and in the preceding one we have dealt with some of the qualities of living things and of their component materials. The general outcome is a conviction that the whole organic world possesses certain unities in the way of activities leading to individual maintenance and to the perpetuation of the kind, of cellular organization, and of similar physical and chemical substances. All of these considerations are helpful as we proceed to the subject of organic history, because they suggest that the process by which organisms have gained their varied individual qualities is essentially the same in kind, however diverse the products may be.

CHAPTER III

THE MEANING OF EVOLUTION

IN ITS effort to comprehend the nature and significance of the world, the human mind begins with the thoughts and feelings and observations of conscious life. During the years of childhood, events are individual and separate, but as experiences accumulate they come to be associated according to their natural relations; and the process of organizing thought continues by virtue of the higher qualities that are the distinctive attributes of the human type of mentality. The items of experience no longer remain unrelated as they were at first, and with increasing clarity they reveal a consistent order of occurrence and regularity of procedure. It is this order with which we are concerned.

Evolution is the word employed for the regular changes in nature. When it was first used in science it was applied to the process of transformation during the lifetime of an individual, as the growth of a plant from a seed or of an adult animal from an egg. But gradually it came to have the more comprehensive meaning of the present day. In its completeness, evolution is a body of organized knowledge concerning the objects of experience, the natural events in the way of change that confront us everywhere, and the past history by which things have come to be what they are. Perhaps the word is more often used for the process of transformation itself, but our knowledge of this process is gained by a due consideration of the qualities and relations of concrete things, and hence the latter are integral components of the whole subject. For this reason the definition of evolution is given in general and comprehensive terms.

THE REALITY OF UNIVERSAL NATURAL CHANGE

Defined in more concise terms, evolution means *universal natural change*. Like every other so-called law of nature, the

16 THE COMING AND EVOLUTION OF LIFE

simple phrase states the general conclusion drawn from the immense body of ordered, classified facts which students of nature have amassed through their labors. Even though we may not have formulated our thoughts in definite scientific terms, yet all of us are aware of the *reality* of universal natural change, for the evidences are the events of everyday life and experience. Everyone is familiar enough with the profound changes that mark the passage of his years from infancy to youth and to older age, both in body and in mentality. Such changes may be very slight in the shorter period of a month or a year, but in time they accumulate to large and obvious degrees. In the briefer annual span of life of a frog, the transformations take place more rapidly before our eyes as the egg produces the tadpole and the tadpole is converted into the final form. A giant redwood tree may require two thousand years for its growth and development, but it is never quite the same even in any two successive days of its long life. Nothing could be more obvious, more familiar, or more natural; if changes did *not* take place we would deem it *unnatural*—that is, something contrary to the orderly ways of experience.

Drawing further upon familiar facts, we know very well that no child is exactly like either of his parents; and if we examine the case of any other living species, we always find that an individual departs in few or many respects from the condition of the one or the other of its progenitors. Here, too, is a natural and a universal fact; obvious to everyone. The parents themselves did not faithfully repeat all of the qualities of the individuals from which they originated. And as some changes and differences come about with each succeeding generation, these inevitably accumulate as longer time passes, and so diverse tribes and peoples come into being from the same ancestral beginnings.

It is true that the process of evolution usually calls to mind the greater alterations in the make-up of things for which the lapse of ages is required, such as the origin of the horse of today, with one toe on each foot, from an ancestor with four or five toes, or the development of the human type itself from a progenitor with the nature of the existing apes. It is so with the idea of time or of wealth. Seconds pass to become minutes, minutes accumulate to become years; and even eternity—so far

as we can conceive it—is just an accumulation of seconds. The word wealth is usually associated with thousands or millions of dollars, but here, too, it is evident that even the largest store of possessions is but one penny added to another over and over again; small though it is, the penny is just as truly wealth as any amount of pence which may be amassed.

Evolution is conceived in exactly analogous ways. In the organic world, nature's processes universally work so that offspring differ from their parents, and science has discovered many of the reasons for this process of biological variation. With every new generation, therefore, what we may justly call an elementary episode of evolution takes place, because with each successive step something in the way of a natural change occurs which is added to what has been previously accumulated, to the end that larger and greater diversities are brought about.

EVOLUTION EVERYWHERE

So far our attention has been directed to the natural changes among living things, which constitute the subject matter of *organic evolution*. But, wherever we may look, the whole known universe displays exactly the same kind of orderly transformation; thus organic history is only a part of what must be called *cosmic evolution*. The surface of the earth is daily altered as the winds and the rains transport soil from where it was to another place; in time these natural influences wear down mountains and build out the shores where the rivers are discharging their burdens of silt. Such deposits become solidified to form new strata of rock; and by the strains and stresses of the earth's crust they may be raised to great heights as younger mountain ranges. The geologist has learned how to interpret the earlier changes of the earth in terms of the elementary episodes of daily transformation which confront us everywhere. The astronomer and the physicist likewise have worked out the history of the evolution of our own solar system and of similar configurations in the expanses of the heavens, by availing themselves of the information they can acquire from their observations, despite the comparatively brief period in which these may be made. Even chemistry has recently become evolutionary, because it has been discovered that the so-called elements themselves fall into

18 THE COMING AND EVOLUTION OF LIFE

a consecutive series, some of whose members are actually known to change into other elements.

From all of these considerations, we are able to comprehend something of the unity of the whole knowable world for the same kind of natural change is disclosed universally. We also gain a truer perspective with regard to our own immediate subject of organic history seeing it as only a part of an all-inclusive whole, however important to us may be the latest paragraphs which record the origin and development of our own kind. We cannot comprehend infinite time, it is true, but at least we can realize that long ages were required for a nebula of stellar space to organize into a solar system with its planets and central sun. Still other ages were to pass before our earth cooled, crystallized, and proceeded with its geological and chemical evolution to a state when living chemicals first came into being. Then began organic evolution—the natural history of living things—which has gone steadily forward in its own way and with its own particular accomplishments while at the same time concurrent phenomena of change have continued throughout the lifeless divisions of the world.

EVOLUTION—A SCIENCE

Conceived in these ways, it must be clear that evolution is not to be termed an "hypothesis," if the word be taken to signify a chance guess or speculation, because it is really an interpretation of the past in terms of actual experience at the present time, and experience is verifiable fact. The word "theory" is perhaps more acceptable, but even this suggests that the final proof has not been obtained. Evolution is a *science*, and it meets all the criteria of sure knowledge which were discussed in the first chapter. Hence, we are entitled to speak of it as a "doctrine" because this word means something so well established as to be the accepted, concise statement of the significances drawn from verified, classified, and summarized experience.

ERRORS CONCERNING EVOLUTION

It will be well to consider here some of the many misconceptions regarding organic evolution in order that the way may be cleared for the more circumstantial discussions of the later

chapters, and also that its real meaning may become clearer. Perhaps the most prevalent error is the idea that evolution is remote in time and place, and that even if it were real, its work is ended. The fact of the matter is that what we know about it is discovered by a common sense analysis of the orderly processes known to the immediate experience of the present, as we have shown. Again, evolution is often regarded as a doctrine put forward on the human authority of one or another student of nature; but the teachers of evolution themselves recognize no authority other than the facts of organic constitution and change.

Those who are unfamiliar with the progress of knowledge are prone to hold the erroneous idea that Darwin was the first proponent of the doctrine, and that Darwinism and evolution are synonymous. A subsequent chapter will effectually dispose of this mistake, and it will show that during many centuries before Darwin there were naturalists who recognized the reality of organic transformation, and who also concerned themselves with the interpretation of the process of evolution in terms of everyday phenomena. It is true that Charles Darwin exerted an extraordinary influence upon biological thought in the field of evolution, and that his fundamental analysis of the natural course of evolution led to a wider acknowledgment of the reality of the process than otherwise would have been the case. Furthermore, Darwin did not hesitate to apply the general principles of evolution to the human type along with all of the rest of the animal series.

These are some of the reasons why many unacquainted with the facts suppose that Darwin himself was the originator of the whole doctrine. And, incidentally, we may here dispose of another prevailing error, namely, that evolution and Darwinism center about the relationship of mankind to apes and monkeys. That relationship is indeed one of the topics with which biological science concerns itself, but were it not for our own human nature this matter would not be deemed any more important than the affinities of the horse and the zebra, or the insect and the centipede.

More worthy of discussion is the view held by many that evolution is a process resulting always in progress. The ele-

20 THE COMING AND EVOLUTION OF LIFE

mentary forms of life were necessarily simple, of course, and from them have come the more complex animals, justly called higher. But many instances are known where the history is one marked by regression, either in certain structures alone or in the whole organization of the animal, as among the most degenerate parasites. The one thing that is essential is *adaptation*, and sometimes this may be attained more effectively by the loss of unessential parts, which is just as truly evolution as the acquisition of a more elaborate structural condition.

EVOLUTION AND DESIGN

Adaptation strongly impressed the minds of evolutionists even in the earlier centuries of thought. Aristotle devoted much attention to it, and he endeavored to account for it by postulating a "perfecting principle," ascribing to the control of the evolution of living things something analogous to what is called "purpose" in human thought. While such a view, called *teleology*, may have a certain value in philosophical speculation, it is not tenable in science. For all that is justified by the facts of organic history is the statement that the processes of nature have brought into being the known kinds of organisms which are for the present the varied end results of evolution, but which cannot reasonably be regarded as the inevitable or necessary results of a "purposed" production. To Aristotle, the whole scheme of nature seemed imbued with an intangible direction to the end that mankind itself arose and that all other things originated for the benefit of man. But biologists of today do not attribute such outstanding importance to humanity and to human interests, for these are but individual items among the many.

EVOLUTION AND PHILOSOPHY

Proceeding further along this line of thought, we meet a much-discussed subject of real importance, namely, the relation of evolution and of the whole body of science, of which it is a part, to philosophy. In the older days, philosophy included not only the mass of known fact but also the speculations arising out of experience. Gradually evolution gained its character of organized knowledge with precise methods and definite aims as outlined in Chapter I.

EVOLUTION AND RELIGION

Finally, we must consider the relation of evolution and science to religion—a subject of great concern on account of the many misconceptions which it is helpful to dispel as early as possible. Any religion of any time and people is a system of precepts governing conduct, or piety; secondly, a ritual of sacrifice, worship, and discipline; and finally, a belief in the existence of powers apart from and beyond the world of material things, or a theology.

Thus in formal terms the word religion refers to the attitude and reactions of an individual to the whole world in which he finds himself. Science undertakes the duty of understanding and describing this world, and thus it offers to the human mind definite conceptions which are to be taken into full account in working out a religious system. It is not the obligation of the one to dictate to the other; they meet, but they do not overlap. It is true that many a religion has incorporated into itself accessory beliefs which purport to account for nature and its ways by recourse to supernatural powers; and far too often such traditional items of religion are overvalued in comparison with the worthier elements of fundamental significance. And when these tenets are out of harmony with what science has discovered, there seems to be a conflict between the latter and the beliefs of religion. But truth cannot contradict truth. An honest effort to deal with the situation will begin with the sure knowledge at our disposal regarding matter and energy, life and living things and their proven history of natural transformation, and it will then proceed to the adoption of a system of piety and worship with full recognition of the characteristics of the material world as science knows them.*

OUTLINE OF THE DISCUSSION

The true conception of organic evolution, now clarified by the foregoing paragraphs, is the product of a long and interesting development throughout the centuries from the time of the Greeks onward. This history is the subject of the following chapter. Before we pass to its consideration, it will be well to

* See "Energy and Matter" in this *Series*.

22 THE COMING AND EVOLUTION OF LIFE

outline the general plan of the later chapters which deal circumstantially with the facts and principles of evolution.

The whole subject is divided into two parts. In the first place, we are to deal with the evidences provided by organisms themselves showing that animals are in reality the products of natural changes, and for the time all queries as to the dynamics of evolution may be deferred. Secondly, we are to scrutinize the working of nature in the case of living things to discover the factors which now bring about the elementary episodes of evolution; and in so far as these factors are consistent and uniform in their operations, it is reasonable to believe that they have had their effects in the past in the same ways in which they have today. Thus they provide the dynamic explanation of the larger changes involving long periods of time which have resulted in the origin of the diverse kinds of animals and plants now known to exist.

When the universality of organic evolution is kept in mind, it is not difficult to appreciate the fact that the evidences as to the reality of evolution are co-extensive with our knowledge concerning animals and plants. Every single item regarding every species offers itself for use in one connection or another. Hence the categories of evidence are the organized departments of zoological and botanical facts which have gained their own individual forms mainly during the last century and a half.

Adopting a simplified scheme, we are to deal first with animal structure, or *morphology*. This first major division of zoology possesses its own body of material data and its own method of interpreting them, with the demonstration of evolution as the outcome. Sometimes this department is treated in two sections, *i.e.*, *classification* and *comparative morphology* in the stricter sense; but these are alike in their mutual concern with anatomical facts and in their evolutionary interpretations of their materials by identical principles, even though their points of view are somewhat different.

The second major division of zoology includes the phenomena of development, or *embryology*; this brings together the information regarding the individual histories of animals in order to treat them comparatively, with the result that additional evidence of evolution is obtained.

The third department is *paleontology*, which deals with the known relics of animals of the past which have no descendants of their kinds to represent them today. However remotely in time these organisms may have lived, their interpretation is made on the basis of knowledge concerning organic nature of the present; the material facts themselves and their evolutionary explanation are not the same as in the case either of morphology or of embryology, but the result is the identical formula of evolution.

The fourth department includes the facts of *geographical distribution*, which, like almost all of the others, are so familiar that it seems strange their evolutionary significance was not discovered long ago. As this division is not to be discussed later, a brief statement at this point will serve to indicate the nature of the evidences in question. The fundamental fact is that the species of animals and plants are not distributed uniformly over the earth, but occupy more or less delimited areas. The jaguar and the puma are inhabitants of the American continents and they do not occur in the jungles of Asia where the tiger exists; the latter is not found in the Americas, even though there are wide regions of the New World where it could live with equal ease. In the next place, it is found that the species of neighboring areas more nearly resemble one another than forms of widely separated localities. This need not be so if organisms are the products of supernatural creation, but it is the logical relation which would follow if an ancestral stock gave rise to divergent kinds of descendants by evolution.

Perhaps the most significant data are provided by the species of insular areas. The lizards and birds of the Galapagos Islands, which lie off the coast of Ecuador, are closest in nature to the reptiles and birds of the neighboring parts of South America; hence they are to be interpreted as the diverse descendants of ancestors which reached these islands from South America. In the same way, the animals of the Azores Islands are most like those of the adjacent continent of Africa. From such facts as these, science formulates the general principle that *the degree of resemblance displayed by the organisms of two regions corresponds in general with the degree of proximity or isolation of the two areas*—a principle that gains in evolutionary significance

24 THE COMING AND EVOLUTION OF LIFE

with increasing clearness as the material evidences are accumulated.

Each of these divisions of zoology has its own characteristic materials and its own elements of strength, and each of them attains its results in its own manner. Our confidence in the reality of their identical meanings is still further increased when we realize how they mutually support and corroborate one another.

When we come to the dynamics of evolution, we will deal with two kinds of natural forces which are required for the workings of the process. First, there are the *primary factors* which originate the organic differences without which evolution cannot take place. Already we know that diversities do arise universally with each new generation of every species; hence the task here is to discover what reasons there are for the obvious facts. In the second place, we must consider the *secondary factors* of evolution which somehow carry on the majority of the parental characters, together with the minor details of diversity which arise as the effects of the first class of influences. Even in advance of a scientific analysis we must realize that something works naturally in these ways, for the fact of biological *heredity* is quite as evident as the fact of *variation* itself.

CHAPTER IV

THE HISTORY OF THE CONCEPTS OF EVOLUTION

LIKE all of the material things with which it is concerned, human knowledge itself has grown from crude and simple beginnings to be what it is; evolution is quite as clearly evident in the history of thought as in the case of the human thinker himself. Letters and literatures, the arts of practical life and of esthetic enjoyment, and the organized bodies of scientific knowledge have developed with the centuries to be the treasured possessions of humanity of today.

GROWTH OF THE EVOLUTIONARY IDEA

Our interest centers mainly about the principles of organic evolution, concerned with the natural history of living things; they are but a portion of our intellectual heritage, included with all of the rest in the evolution of human thought. A review of their origins is interesting in itself, especially because an incidental result is the discovery that the central idea of evolution is by no means a product of recent times, as so many suppose. This idea was presented in definite terms many centuries ago as a part of a general conception of orderly and natural changes manifested by all material things. Indeed, in the earliest days, there was little in the way of a classification of knowledge into distinguishable departments or subjects; with the exception of mathematics and the primitive astronomy of the times the materials of our present well-separated sciences were intermingled in what, until recently, was an all-inclusive philosophy of nature. And the earliest germinal concept of organic evolution was at the same time a fundamental idea of inorganic natural history as well.

It is true that the principles of organic evolution as they are now formulated are largely the products of the last century and

26 THE COMING AND EVOLUTION OF LIFE

a half. This may be termed the *modern* period in the history of our subject, although its beginnings are only to be defined arbitrarily. Equally vague are the limits of the *medieval* period which merges almost insensibly into the modern, as in turn its concepts developed in unbroken connection from those of *ancient* times. Extending still farther back into the indefinite past is the period of *antiquity*, the character of which may be judged partly from the myths and fancies surviving in the records and partly by observing the habits of thought among our contemporary ancestors, the primitive peoples of today.

It is legitimate to begin with the earliest of the eras enumerated because early man accomplished the first essential for the development of science by accumulating a fund of information to be transmitted, to be amplified, and eventually to be definitely organized. Primitive human beings were forced to learn much about the objects surrounding them. Some animals and plants served as foods, while others were worthless or harmful; some could be domesticated and cultivated, while others could not. Slowly, then, the materials of knowledge were accumulated, to be available when the modes of thought developed to the point where reasoning and generalization were possible. Throughout these early times, anything in the way of an explanation was framed in purely human terms, that is, anthropomorphically. Man could fashion a canoe and build a dwelling, but he could not make trees or mountains or clouds; these things existed, they had been made, and so it was inevitable that their origin was attributed to human-like beings, more powerful than man, and invisible like the human dream-self which belonged, supposedly, to the world of unseen personalities.

THE IDEAS OF THE GREEKS

With the Greeks we enter a new era, both because they were keen observers of their natural surroundings and also because they developed the forms of synthetic as well as analytic thinking. They were the first to make systematic efforts to find and to describe the order of nature, and to discover in their experience the terms in which the *natural* history of things was capable of statement. Thales (*ca.* 640-546 B.C.) was one of the first to seek for a rational explanation to replace the mythological

interpretations of the times. One of his main ideas was that water was the element from which all things had arisen, and that it constituted the great common denominator of nature, as it were. Anaximander (*ca.* 611-547 B.C.) pictured the earth as fluid in its early state, and, as it dried out, as forming the germs of living things, with human beings as its first productions. Crude as his scheme may seem to us, at least it has merit so far as it included a natural order in the origination of living things.

Among the physicists, Heraclitus (*ca.* 535-475 B.C.) is noteworthy because he evolved the idea of ceaseless movement everywhere in the world in the statement that individual living and lifeless objects are but temporary combinations, as it were, in an incessant flux of matter and energy. This is now one of the basic teachings of science.

To Empedocles (*ca.* 490-430 B.C.) is accredited the first definite statement of the concept of evolution, both in the case of living and of inanimate objects. He was a poet and a physician as well as a naturalist. All things, he says, are combinations of four ingredients—earth, air, fire, and water; their obvious differences are due to the varying proportions of these components. They are activated by forces which combine and dissociate, analogous to the human motives of love and hate. By purely natural processes, plants first came into existence as living things and animals were produced later. The latter did not appear in their full forms, but originated as separate parts, which eventually united by chance to become all kinds of assemblies. But only those combinations which proved workable or adaptive survived, while the unfit were eliminated.

Despite the inherent errors in the whole program, here are at least three of the outstanding ideas of modern evolution: a natural order of the origin of living things, the chance operation of the factors of evolution, and a kind of natural selection by which the elimination of the unfit results in the survival of only those which are adaptively constructed.

ARISTOTLE AS A NATURALIST

Far overshadowing all who preceded him, Aristotle (384-322 B.C.) stands as an unrivaled figure for many centuries. A

28 THE COMING AND EVOLUTION OF LIFE

great philosopher and metaphysician, he was a keen naturalist in the fullest sense of the word. His boyhood at the seashore gave him an acquaintance with many of the humbler forms of living things in addition to the larger better known backboned animals. He expressly directed attention to the interesting features of the lower types "for in all animals there is something to admire because in all there is the natural and the beautiful." He wrote four fundamental essays concerned respectively with the structure of animals, their modes of locomotion, their embryological histories and reproductive accomplishments, and the "vital principle" that supposedly activates them. The common plan of organization which exists in related animals was duly recognized, as well as the adaptive nature of the diversities superimposed upon an identical structural foundation. Vestigial structures * were also cited as items which carried out the unity of an architectural plan. The principle of a functional division of labor is clearly stated by Aristotle.

Whatever the ultimates might be, life to Aristotle was not a separate entity, but something inherent in the organization of the materials of which organisms were composed. Long anticipating the correct interpretation of development as stated in modern terms, he pictured the stages of a single life-history as becoming progressively more and more complex, and not merely as the enlargements of an organization already present in the germinal beginning. The fundamental process of biological inheritance was also duly stressed, although Aristotle believed that the modifications acquired during a lifetime were added to the hereditary stream. He is, therefore, the first to express a view more fully worked out in the writings of Buffon, Erasmus Darwin, and Lamarck, and one which is currently called the Lamarckian hypothesis.

To Aristotle the myriad forms of living things appeared as a consecutive series from the simplest up to the highest among the plants, and so on to the lowest of the animals, which led, by ascending degrees of complexity, to the most elaborate. The human type was regarded as the culminating term in this gradu-

* A vestigial structure is an imperfectly developed part or organ which has become more fully developed in an earlier stage of the individual or in a past generation.

ated series and not as a unique creation outside the scope of animate nature. In so far as all of the distinctive kinds of living things were considered as the products of natural formative processes, Aristotle is justly to be regarded as an advocate of evolution, even though he did not contend that higher forms had actually arisen from progenitors like some of the more primitive organisms of his series.

- The larger scheme of evolutionary procedure, according to Aristotle, begins with the materials of which organisms are composed as the first requisite. These are molded into one form or another under the control of a "perfecting principle" to the end that they gain the structural and functional characters which make for efficiency. Aristotle recognized the outstanding organic quality of adaptation as a general attribute of existing animals and plants. But in sharp opposition to Empedocles, he upheld the view formerly expressed by Anaxagoras (*ca.* 500-428 B.C.), which regarded adaptation and all other adjustments in nature as the product of an inherent *purpose* or *design*—a view that bears the name of *teleology*. Indeed, the whole scheme of nature seemed to be devised for the purpose of human benefit, difficult as it may be to harmonize such an idea with the pains and tragedies of mortal existence. Back of the visible and the knowable are to be postulated "the gods," as the ultimate creators and sponsors of the material universe. Such, in brief, is the cosmic scheme outlined by Aristotle; and, with the exception of the final appeal of mystical and anthropomorphic* character, it is essentially naturalistic and evolutionary throughout.

So high were the merits of Aristotle, so complete and comprehensive were his achievements, that for ages he and his work dominated the intellectual world. The authoritative word of the "great master" was to be taken without question, except for such comment or explanation as might be fitting. But the direct study of nature inevitably declined as the baneful result, and many centuries were to pass before men realized that the advance of human knowledge required not only a proper deference to the thoughts of those who had gone before, but also an appeal to the only real authority—the natural facts themselves.

* Anthropomorphism (adj. anthropomorphic), the representation of the Deity under a human form, or with human attributes and affections.

BELIEFS OF THE EARLY CHRISTIAN FATHERS

In western Europe the custody of classical learning came into the hands of the clerics, while elsewhere the Arabs perpetuated the lore of Aristotle. Thus it came about that the early Christian Fathers were believers in natural evolution because they adhered to Aristotle's views regarding cosmic history. Saint Augustine (354-430 A.D.) explicitly rejected the literal account of creation as given in the first chapter of Genesis, viewing it as an allegory. Indeed, he went so far as to discard the idea of an immanent Power controlling the daily events of life, and contended that when the world was first formed it was endowed with the innate capacity to develop in all of its departments in an orderly, natural way. Such views were still in vogue among the clerics as late as the time of Saint Thomas Aquinas (1225-1274) and Giordano Bruno (1548-1600), although about this time the literal interpretation of the so-called Mosaic account, to the effect that the world was created supernaturally in six of our calendar days, gained ascendancy through the influence of the Jesuit philosopher, Francisco Suarez (1548-1617), and his colleagues. Contrary to the usual opinion, therefore, the doctrine of supernatural creation was not original in the history of theological doctrine, but it was instituted after a long period when Aristotelian evolution had prevailed.

THE MIDDLE AGES

The later centuries of the vaguely defined Middle Ages are marked by real progress in the development of the concepts of science and of evolution through the work of three groups: the philosophers, the medical men, and the naturalists. Francis Bacon (1561-1626) is pre-eminent among the philosophers because of his firm advocacy of the sure methods of scientific inquiry, including experimentation. Furthermore, he correctly conceived the natural process by which higher species arise as one involving their direct descent from pre-existing kinds. Although the French philosopher, René Descartes (1596-1650), was a special creationist, yet he showed some understanding of the principles of development. In the main, however, subsequent philosophers were concerned with the theoretical exercises

to which they were led by their direct observations of natural objects.

The very nature of their profession compelled the practitioners in medicine and surgery to become acquainted with the biological facts of anatomy, and consequently they amassed a large store of information which was available later when the likenesses in structure between the human type and other higher animals came to be appreciated. Hippocrates (*ca.* 460-377 B.C.) corresponds in a way with the pre-Aristotelians by virtue of his organization of the subject of medicine as it was known in his time. The great name of the earlier centuries of our era is Galen (130-200 A.D.), who brought together the results of his predecessors and supplemented them by his own comprehensive studies on the structure of man and of other higher animals: Just as the dicta of Aristotle dominated thought of a comprehensive compass, so for twelve centuries the words of Galen were taken as the ultimate authority in anatomy. Here, too, it was necessary to return to direct observation and to defer to the writings of others only so far as they were corroborated by the actual facts. The new prophet was the Belgian anatomist, Andreas Vesalius (1514-1564), who inaugurated a new epoch when he worked out and gave to the world his elaborate studies on the human body, so beautifully illustrated that the drawings were ascribed to Titian. William Harvey (1578-1657) described the fundamental facts concerning the circulation of the blood in higher animals, and he also devoted himself to the analysis of the earlier stages in development as no one before him had done. This English physician contended correctly that "all organisms are in some sort derived from somewhat similar germs." The true unicellular nature of the initial germs could not have been known to him, but he rendered a real service to biology when he recognized the reality of progressive developmental changes among all organisms.

Meanwhile during the sixteenth century increasing numbers of students engaged in the compilation of a great mass of information concerning animals and plants, thus beginning, in a modern way, to assemble the verified facts which were later to become more adequately organized. Wotton, Gesner, Jonston, and Aldrovandi were the authors of huge folios which give merit

32 THE COMING AND EVOLUTION OF LIFE

to their designation as the "Encyclopedists" of medieval natural history.

Another notable era began when Hooke and Grew, Swammerdam and Leeuwenhoek devised the first crude microscopes—thus opening up the whole world of minute organisms which are so indispensable for an understanding of the complete animal array and its meaning. Furthermore, the new devices made it possible to see the smaller parts which make up organisms, to analyze these parts into their finer constituents, such as the tissues, and thus to prepare the way for the establishment of the cell-doctrine by Schleiden and Schwann in 1838 and 1839.

THE MODERN ERA—LINNAEUS TO LAMARCK

The late eighteenth century and the early nineteenth century witnessed a great increase in knowledge of the actual facts of natural history, but their greater accomplishments were made in the organization of such materials to form the fundamental departments of zoology and botany. The famous Swedish naturalist, Carolus Linnaeus (1707-1778), rendered immortal service by instituting systematic methods of classifying living things, each particularized according to its kind by a *species* name as well as a *genus* name for the group of substantially similar types. These genera were in turn assembled into larger groupings; and all of the lesser and greater assemblies were characterized by concise and simple descriptions. The Linnaean methods are the standards today, although we now realize that the manifest likenesses serving for classification are evidences of real relationships and not the outcome of a similarity of plan in the mind of a supernatural Creator, as Linnaeus contended.

Growing interest in the structural qualities of organisms, whether or not they are sufficiently outstanding to be recorded in a scheme of classification, led to the organization of the second distinct department of natural history, *i.e.*, *comparative anatomy*; and again it is a special creationist, the French naturalist, Georges Cuvier (1769-1832), who stands forth as the leader in this work. This same great naturalist was largely responsible for the establishment of another department of zoology, *paleontology*, which is concerned with the relics of now extinct organ-

isms. Despite the paucity of fossils known to Cuvier and to his contemporaries, Smith and Lamarck,* and even though Cuvier was unwilling to adopt the evolutionary interpretation, the significant facts of fossil nature were brought into definite relations, and paleontology was started on its way to become the great and valuable department of biology which it is today.

While the materials of zoology were slowly and surely approaching final arrangement, even though many who rendered valuable service were advocates of special creation, the old ideas of natural evolution were beginning to appear in modern form and with a surer foundation in the established facts of biological science.

The pioneer of this new period was the French naturalist, Comte de Buffon (1707-1788), who held the Aristotelian view that species form a single ascending series from the simplest to the highest, and in addition he contended that every distinct type of today had arisen by actual transformation from some earlier ancestor of simpler nature. He cited the accomplishments of man himself in the production of new and diverse domesticated animals and plants—a group of facts of which Charles Darwin made much in the succeeding century.

As regards the process of evolution itself, Buffon developed the idea that larger differences among species come about through the accumulation of small natural variations, that organisms are plastic under the direct influence of the environment, and that such changes as are thus induced by external factors are transmitted to offspring along with the older basic characteristics. Thus Buffon proposed a program—the “inheritance of acquired characters”—which was more amply worked out by his successors and which has required a long time and laborious research to prove erroneous.

Erasmus Darwin (1731-1802) is another important figure of the period. He was a poet and a physician as well as a keen naturalist, whose abilities were destined to manifest themselves in higher degree in his illustrious grandson, Charles Darwin. The elder Darwin was a thorough believer in natural evolution, and he added to Buffon's formula for its accomplishment the element of indirect or functional responses to outward stimuli;

* See “The Earth” in this *Series*.

34 THE COMING AND EVOLUTION OF LIFE

and he contended that the changes so induced were passed on to future generations.

The French naturalist, Lamarck (1744-1829), is hailed as the greatest figure of the early nineteenth century, and his fame is well merited. Believing at the outset in the fixity of species, he later became convinced that they had arisen by natural evolution. At first he held the view that organisms formed a linear series of types from low to high; subsequently, however, he pictured the lines of diverging ascent as the counterparts of the branches and limbs of a tree, which is the accepted scheme of biology today. He believed with Buffon that the evolution of plants had been accomplished largely through the direct work of external influences, but so far as animals are concerned, he held with Erasmus Darwin that reactions to surrounding circumstances induced changed habits and altered structural features which were transmitted to the progeny of the organisms so modified. It is because Lamarck so elaborated his program that the hypothesis of the inheritance of acquired characters conventionally bears his name, although the basic concept really appears in the writings of Aristotle.

THE SIGNIFICANT WORK OF CHARLES DARWIN

The established views of the present regarding nature's workings in evolution are so largely the outcome of the pre-eminent writings of Charles Darwin (1809-1882) as to give some grounds for the prevalent error that Darwin founded the doctrine of evolution. It is impossible to overestimate the importance and effects of Darwin's contributions to the subject because their influence has penetrated into many departments of human thought that are held to be more or less separated from the biological sciences in which his primary work was done. Although zoology and botany had reached a stage in development when their larger meanings were becoming more apparent, and although inductive methods had made possible a clearer statement of the dynamics of organic nature, yet Darwin brought to the consideration of these matters an extraordinary capacity for comprehensive and clear thinking, strengthened by unusual training and experience. After unsuccessful efforts to qualify for the professions of theology and medicine, in 1831 he was appointed

naturalist of the government ship *Beagle* and spent five years on this voyage in the direct study of animate and other nature in various parts of the world. His careful record of his observations during these years reveals the germinal beginnings of many ideas that came to full fruition in the chapters of the immortal volume, the *Origin of Species*, which appeared in 1859.

Darwin's services to science were rendered in both of the major departments of the whole subject of evolution, concerned respectively with the reality of natural change in the descent of species and with the program by which nature accomplishes evolution. For the first time he adequately arrayed the accumulated data of morphology, embryology, and paleontology so as to show how they severally and individually disclosed the fact of natural descent. And he developed in full the concept of an ascending series of organic diversities from mere individual differences displayed by the offspring of identical parents, to those of larger degree by which varieties and species are distinguished, and so on to the still greater distinctions of the more widely separated groups of the classified array.

In his formula of evolutionary dynamics, which will be explained in detail in a subsequent chapter, Darwin did not completely reject the inheritance of acquired characters, as upheld by Buffon, Erasmus Darwin, and Lamarck, but he put the greater emphasis on the two factors, congenital variation and heredity, and in this essential respect he placed the whole matter on a surer foundation. The program of the "natural selection of congenital variations" is complete, and it is comprehensive in its scope. For its additional support Darwin adduced the results obtained by human breeders of plants and animals, or "artificial selection." To the special field of "sexual selection" still other facts were brought to substantiate the general conception. Incidentally, Darwin showed how completely the human organism is included within the whole scheme of nature, and that it is not set apart in any essential respect from the rest of the organic world.

Inevitably Darwin's views were subjected to the most violent attacks, but time has shown that his basic ideas were correct. Minor details have been proved to be erroneous, it is true, but the amazing advances in biological knowledge during the latest decades, especially as regards the central process of heredity,

36 THE COMING AND EVOLUTION OF LIFE

have substantially confirmed the main elements of the formula of natural selection as proposed by Darwin.

A summary review of the whole history of evolutionary thought recalls the presence of the idea of natural change in the writings of the Greeks, as the product of the correct methods of analysis and synthesis which they were the first to employ. The terms in which evolution was then stated seem somewhat naïve to us of the present, but they could not have been otherwise until knowledge concerning living things had become organized into the definite, classified categories of the later centuries. And now our confidence in the wholly natural production of the various kinds of living creatures is strengthened by concrete knowledge concerning the influences which induce real changes in organic make-up, and the way the physical machinery of heredity works so as to carry on qualities from one generation to another.

CHAPTER V

THE INTERPRETATION OF ANIMAL STRUCTURE

BECAUSE organic evolution is a universal process, its proofs are all of the assured facts concerning animals and plants; and hence, as we have shown earlier, the classes of biological knowledge are at the same time categories of evolutionary evidence. Our direct examination of the case for evolution begins with animal structure and the manner in which science interprets the facts of animal make-up. Everyone is familiar with many kinds of creatures, and what is already known is quite as available for our present use as the greater knowledge of the zoologist concerning rare species of remote lands and the minute organisms that require the microscope for their scrutiny.

Zoology deals with the structural qualities of animals in two ways. Noting the outstanding features among the many that are exhibited, it employs these for the establishment of a scheme of *classification* of all forms into small and large groups of lesser and greater inclusiveness. More intensive and more comprehensive studies of all of the various organic systems of animals make up the greater subject of *comparative anatomy*. The two are alike as regards the nature of their materials and also in their employment of identical modes of interpreting their facts.

Classification was the first department of zoology to become organized mainly through the adoption of the definite methods introduced by Ray and Linnaeus, as we have duly noted in our historical review. In the beginning, however, the work was prosecuted primarily for the sake of a convenient arrangement of the ever-growing list of known animals; the species themselves were regarded as fixed and immutable kinds descended from primal ancestors created supernaturally. Not until later were the classified groups interpreted in terms of natural relationships and of evolutionary descent.

38 THE COMING AND EVOLUTION OF LIFE

In all, three tasks confront the systematic zoologist: (1) The animals must be scrutinized and described; (2) they are to be brought into natural groups according to their manifest likeness; and (3) these groups are to be explained in the light of what we learn from present-day phenomena regarding the reasons for structural resemblances.

THE REASONS FOR ANIMAL RESEMBLANCES

These reasons are obvious at once if we think for a moment about our own human kind. However they may differ in trivial individual ways, children of the same parents always exhibit the closest degree of likeness in their anatomical qualities. Their resemblances are not to be attributed to identical surroundings, but are clearly due to their *hereditary derivation from the same progenitors*. Cousins are less alike than are the children of one human family, and yet they, too, exhibit the evidence of their common grandparentage in their features of likeness which unrelated human beings do not display. Again, the reason for resemblance is biological inheritance. At the very outset, therefore, we are able to recognize the true cause for likenesses among animals, for in all of our experience no reason other than a common ancestry has been found. There is no known way to account for the similar features of a tribe, or of a so-called race, or of a primary section of the human species such as the Caucasian, without recourse to the principle of common heritage, drawn from our actual knowledge concerning the connection between relationship and resemblance.

LESSER AND LARGER GROUPS OF ANIMALS

The degrees of difference exhibited by what are called *varieties* are interpreted as accentuated and accumulated *individual differences*. Even when the parents are the same, offspring are invariably unlike in some features. And as this is so, we do not appeal to something unnatural when we explain the different varieties of common cats as the more widely divergent natural products of the same ancestry, more remote than that from which all Maltese or all Persian cats have derived their closer resemblances. Still greater degrees of difference separate the

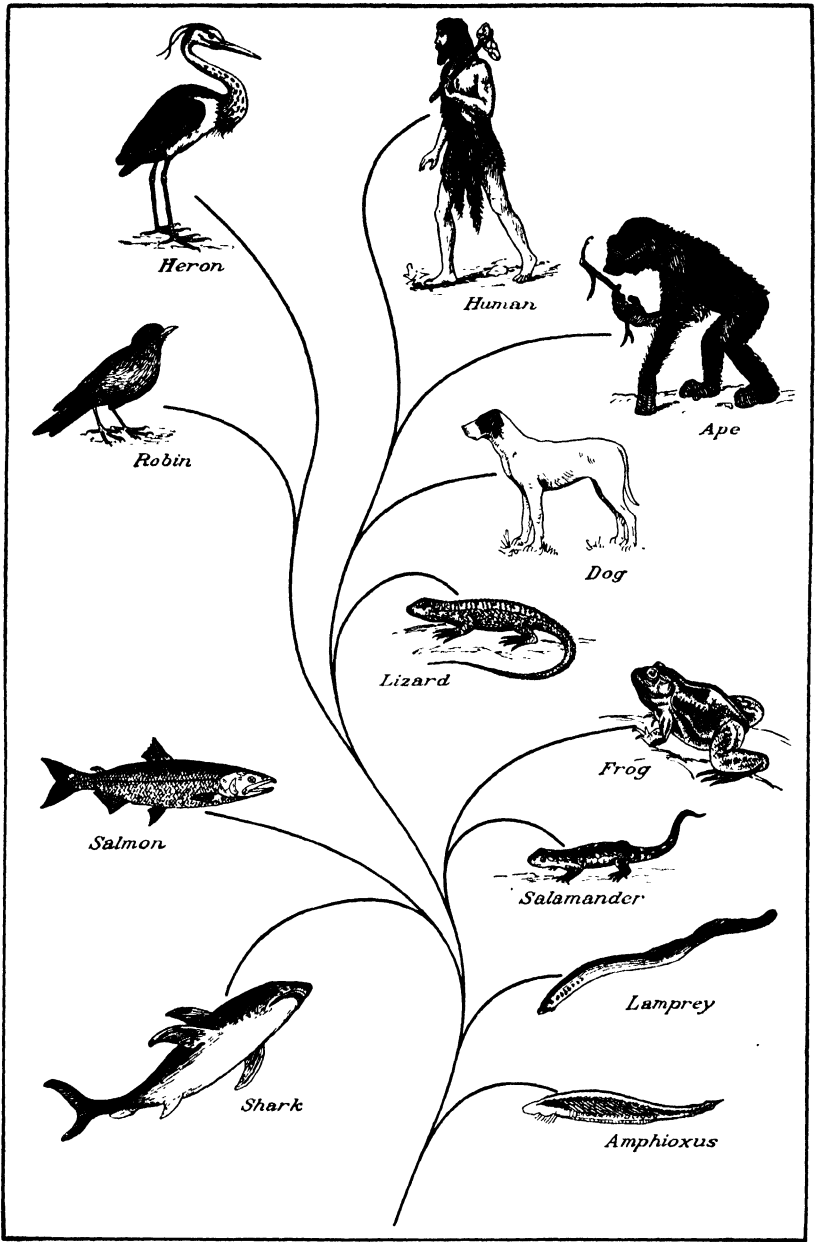

Fig. 2—TYPES AND RELATIONSHIPS OF THE VERTEBRATES

common cat, a lynx, a lion, a tiger, and a jaguar—degrees, amounting to what are conventionally accepted as the distinctions of so-called *species*. Nevertheless all of these animals are substantially alike in what may be termed their “catness,” which is hereditary in all of them and which justifies their reference to the same ancestral origins. Hence species are to be regarded as more widely divergent varieties, as these in turn are interpreted as the results of the accumulation of mere individual differences.

Our familiar animals provide ample material for a still more extensive array whose terms are always to be interpreted in the same way. The larger and smaller cat-like animals, the dogs and the wolves and the like, together with seals and walruses, possess the same fundamental architecture. Rats, rabbits, beavers, and squirrels constitute an aggregation marked also by basic features of likeness among them. The hoofed animals form a “related” group whose members agree in certain distinctions which they do not share with the other *orders*. It seems hardly necessary to re-state the principle according to which the components of each of these orders are held to possess their fundamental common qualities by right of inheritance from the same early progenitors. By similar reasoning, they and all other mammalia—characterized by hair, a four-chambered heart, and other structures—are made into a *class* whose members are still to be deemed relatives in the full sense of the word, however they may have diverged in their evolutionary descent.

Other classes of backboned animals are almost equally well-known, and they, too, fall into a classified arrangement with a similar significance. The hawks and owls have stout limbs and curved beaks, making them the predatory types that they are; herons have long legs and pincer-like beaks which adapt them to their life in swamps; while the penguin is still another variant in body-form and beak and wing. All of these are grouped together as the natural class of birds, together with many others like the running ostrich and emu, because they possess fundamental agreements in all of their anatomical systems beneath their diversities. Lizards and snakes, turtles and alligators form a natural assembly of reptiles with corresponding status. Frogs and toads and salamanders are alike in their distinctions of class degree. And the thousands of fishes conform to one and the

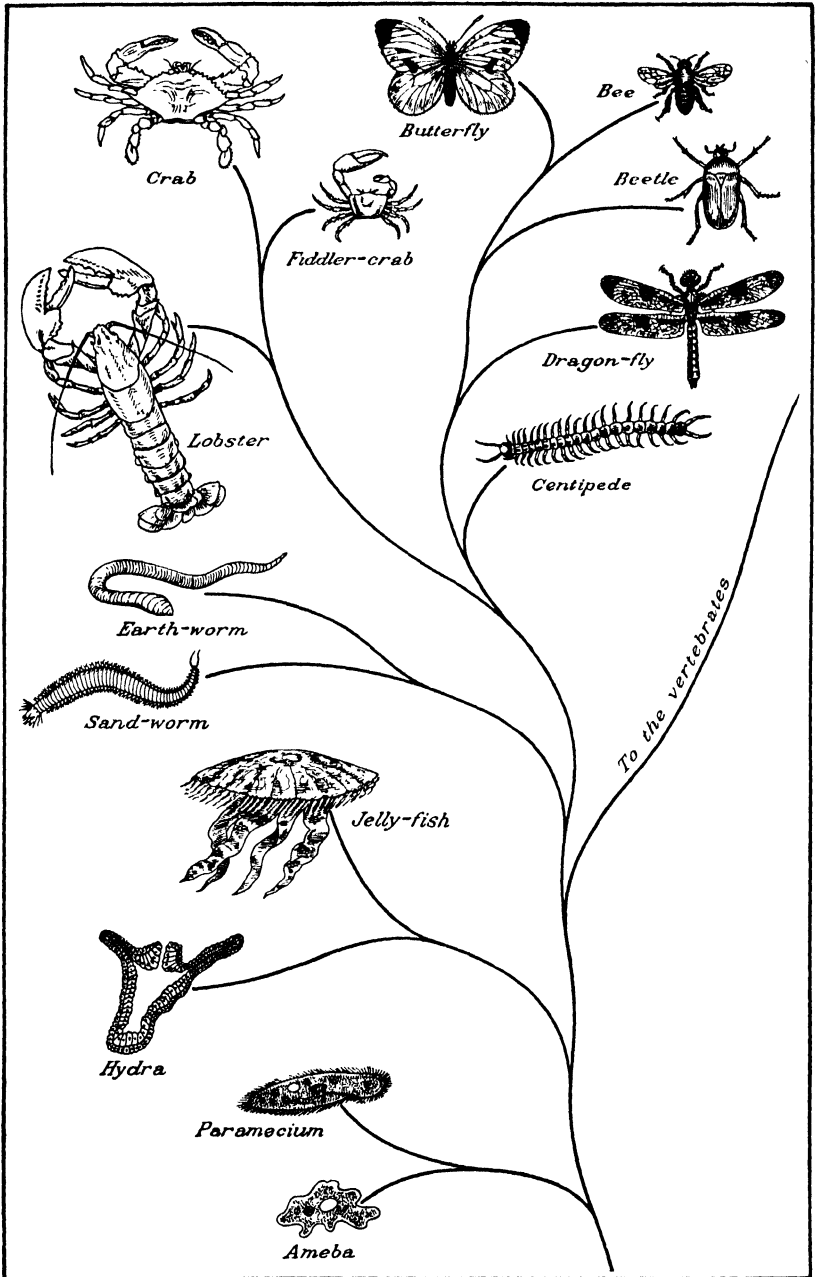

Fig. 3—TYPES AND INTERRELATIONSHIPS OF SOME OF THE INVERTEBRATES

42 THE COMING AND EVOLUTION OF LIFE

same plan of construction while they display an extraordinary diversity in form and in the details of their anatomy.

FURTHER CLASSIFICATIONS

Having brought all of these animals into their natural scheme of relationship, classification proceeds still further with its work and with its analogous interpretation. It recognizes the similar elements of construction in all of the members of these classes, and explains their common vertebrated plan itself as the proof of their common evolutionary origins.

A comprehensive group like the foregoing, which includes all forms with something similar in fundamental make-up, is denoted a *phylum*—a word which means the limb of a tree and which carries out the idea of growth from a single beginning and of the derived nature of the terminal products, the species being the analogues of leaves in the comparison.

All of the other animals of invertebrate nature fall into similar primary phyla on the basis of like structural plans which they severally possess. The insects and their relatives constitute the richest phylum of the whole series. Many of its representatives are so familiar that even without the full knowledge of the zoologist it is easy to understand the mutual evolutionary relationships of the grasshopper, butterfly, beetle, and bee, and of all of these to the simpler prototype presented by the centipede.

Among the water-breathers may be cited the different kinds of crabs, each of which is interpretable in terms of a lobster-like antecedent. Furthermore, all of these creatures, assembled in the phylum *Arthropoda* in recognition of their jointed appendages, are collectively to be derived from some generalized type of worm ancestor, because their diverse segmentation is an elaboration of a uniformly jointed body-plan like that of a worm, and their forked appendages conform to what the marine worm possesses as a simpler, cleft rowing plate.

Below the groups of worms that are even simpler than the earthworm and sandworm stands the phylum comprising the jellyfish, sea anemone, hydra, and the corals; the index of their community of origin is the two-layered organization of the body. At the very bottom of the comparative array is the fascinating

phylum of the one-celled animals, like ameba, paramecium, and the bell-animalcule. All of the phyla of invertebrates, like the vertebrate group, fall into component classes, which are themselves made up of orders, genera, and (ultimately) of primary items in the way of the species with which the work of systematic arrangement and interpretation must begin.

The final result in the present connection becomes clear when the phyla of the entire animal series are arrayed according to the anatomical complexities of their several distinctive plans, and are assigned to their proper relative positions in a complete scheme. The lines of their individual origins are duly drawn from one and the same tree-like trunk, signifying that all of the multifarious kinds of animals *have actually evolved from identical organic beginnings.*

The reason why the zoologist is confident that these lines express the reality of common descent is found in the *identical nature* of all animals in at least three fundamental respects; they are all made up of cells, either one or few or myriads; their living substances are always protoplasm; and they perform the same eight physiological tasks which were discussed in an earlier chapter.*

We have come far from our point of departure when we formulated the principle that likeness means common heritage on the basis of human similarities and their natural reasons; but step by step we have been led to see the *validity of the interpretation with groups of increasing scope and size until the members of the entire animal array come to be explained in terms of true relationship because they exhibit basic similarities of organic nature.* The conclusion that the ameba, the worm, the insect, the fish, and the human being are actual relatives, in the full sense of the word, is difficult to accept only because it seems incredible that the higher forms could arise from unicellular beginnings. Yet classification adopts that conclusion because its principles of interpretation are natural, that is, they are the statements of the meaning of real fact. We shall see later how the facts of development contribute their support to the sweeping statements of classification, which, however, are to be accepted on their own well-grounded merits.

* See page 7.

THE INTERPRETATIONS OF COMPARATIVE ANATOMY

When we pass to the department of *comparative anatomy* we have much more ample materials at our disposal; indeed these are *all* of the facts of animal structure. As we have seen, classification is content to select from among the various structural qualities of animals those features which most clearly indicate the reality of their common derivation, and it pays less attention to the rest. But comparative morphology is quite as much concerned with those structures which are not specified in the systematic scheme and diagnosis as it is with the others. Thus it really provides the materials from which the former subject chooses that which will best serve its purpose.

The complete task of morphology may best be comprehended when it is remembered that all animals are called upon for eight physiological accomplishments, from alimentation to reproduction.* Hence each animal must possess something of a material mechanism for each one of these tasks, and in a sense it might be described as a machine comprising eight kinds of apparatus, denoted the organic systems. Of course the "systems" are not organized as such among the lowest animals, where the "machine" consists of only a single cell, which by itself must accomplish all that is necessary for animal life.

Taking a given function like alimentation, comparative anatomy begins with the protozoan material basis for its performance and passes to the hydra and the jellyfish, where the inner layer composed of numerous cells does the work in question. The lower worms afford a transition to the fully jointed worms which possess a well-organized digestive tube, whose general plan is still to be found in the more elaborate alimentary tracts of the higher segmented animals like the lobster, the crab, the centipede, the insect, and the spider. In a similar way the alimentary apparatus of the vertebrates is followed from its definite organization in the fishes upward to the higher classes which differ from the lower prototypes only in the greater elaboration of the constituent parts of the system and not in the possession of additional components. In the same manner, the structures concerned with each of the other animal functions

* See page 7.

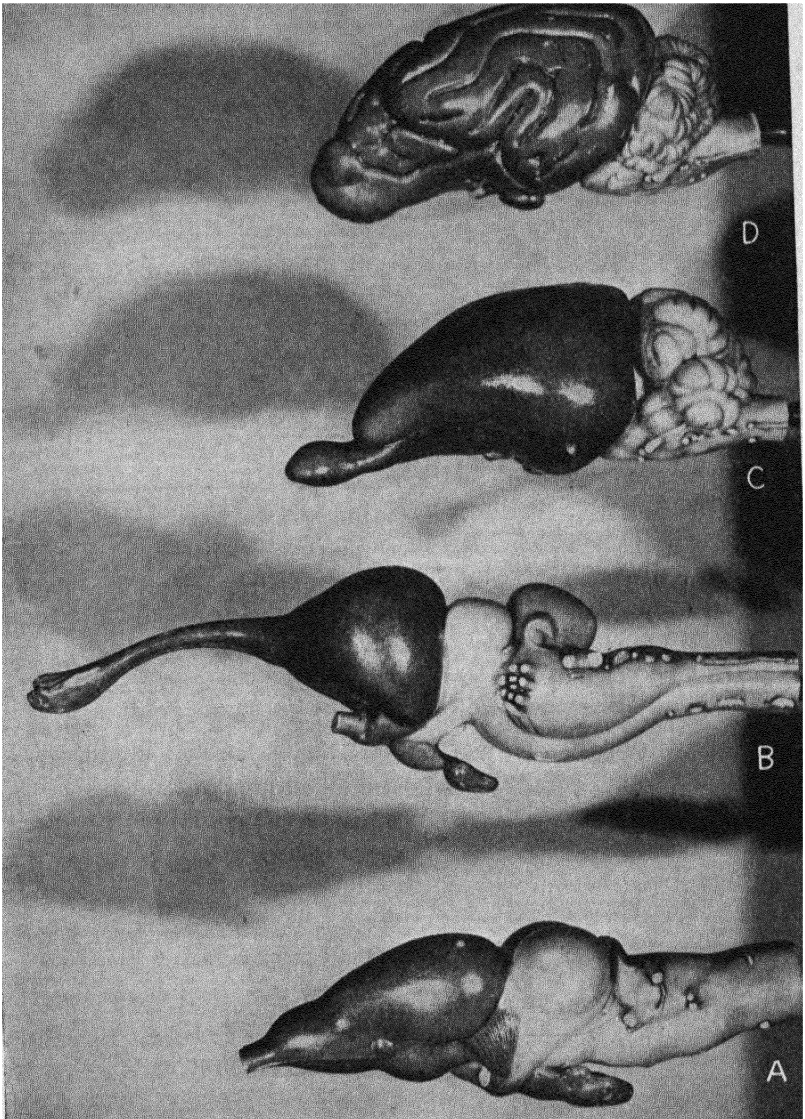

Fig. 4—BRAINS OF VERTEBRATES
A, frog; B, alligator; C, rabbit; D, dog

are noted, compared, and brought into a progressive sequence from lower to higher forms. Wherever it finds *essential likenesses* persisting throughout a series of more or less diversified animals, comparative anatomy interprets them as the evidences of relationship, precisely as in the case of classification.

THE EVIDENCE FROM VERTEBRATE BRAINS

A few illustrations may be cited to make these points more specific and clearer; the only difficulty is to select from the whole body of knowledge concerning the organic systems of animals such cases as may be particularly illuminating. The series of vertebrate brains possesses exceptional interest because it comprises the human organ itself whose evolutionary advance in complexity has gained for it the higher powers by which mankind is distinguished.

Below the fishes stands the animal amphioxus, which has a central neural axis in the form of a continuous tube, with a wall composed of nerve cells and nerve fibers; the cavity of the anterior end of this tube is slightly expanded, and this region is deemed a primitive brain. The fish has a similar neural tube when it is very young, and as it develops, the anterior end forms a series of five parts by the thinning or thickening or the bulging of its walls. These parts are the simple cerebral hemispheres, the optic couch, the optic lobes, cerebellum, and medulla—the last of which is directly continuous with the spinal cord. As we pass upward in the scale we find nothing added to these fundamental parts; indeed, three of them remain throughout substantially as they are in the beginning. The cerebellum increases in correlation with the muscular system which it co-ordinates. The cerebrum enlarges progressively as its constituents become more elaborate, and among the higher mammals its walls gain greater effective surface and bulk by the simple device of folding. As a consequence of their greater enlargement the cerebral hemispheres come to overlap the second and the third parts of the brain, and eventually in the apes and in the human being, for the same reasons, they cause a bend in the axis of the whole brain. But the point of overwhelming importance is that all of the brains in the series comprise identical parts, and that their

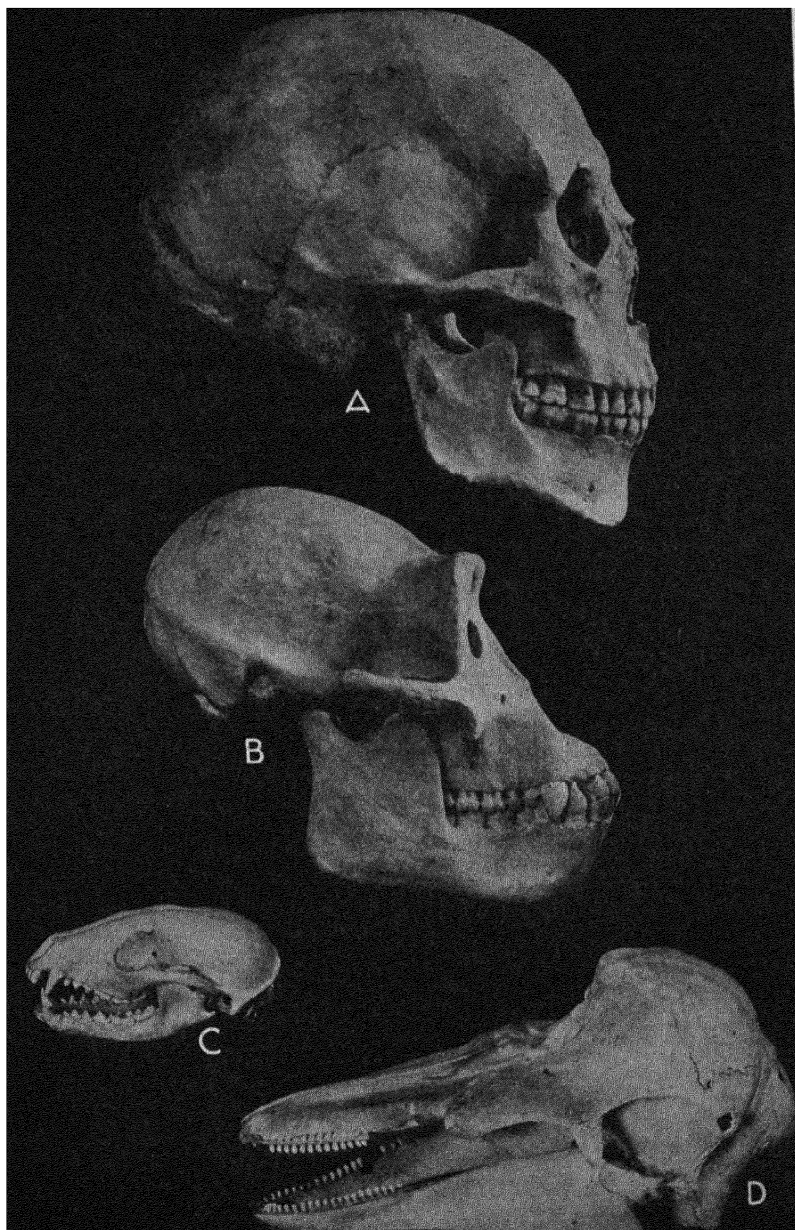

Fig. 5—SKULLS OF VERTEBRATES

A, Eskimo; *B*, chimpanzee; *C*, raccoon; *D*, dolphin. *A* and *B* from skulls in the American Museum of Natural History; *C* and *D* from skulls in Columbia University

48 THE COMING AND EVOLUTION OF LIFE

anatomical correspondences can be explained only in terms of real evolutionary relationships.

WHAT THE SKULLS OF THE MAMMALS SHOW

The bony skulls of the mammals provide further evidences of the greatest interest. The skeleton of the dolphin's head conforms to the wedge-like shape of this part of the body which is needed by an aquatic animal. The skull is gracefully modeled in the dog and in its relatives so as to present another contour. In the ape, the protecting cranium arches higher so as to provide room for the enlarged brain, whereas in the human skull this character is necessarily accentuated, and the jaws have decreased notably in size. Yet, however different all of these skulls may be in outline and in the various degrees of development of their parts, they are made up of identical elements with exactly the same relationships, even to the finer details of their apertures by which the nerves pass outward from the brain to their respective terminations.

SIMILAR EVIDENCE FROM THE LIMBS OF ANIMALS

Equally instructive illustrations are provided by the skeletal structures of the anterior limbs of mammals. The walking and running limbs of dogs are supported by definitely organized bones which have their identical counterparts in the flipper of the seal, in the paddle of the whale, in the arms of the human being and of the ape, and in the extraordinary framework upon which the wing of the bat is spread. Even the elements of the stilt-like leg of the horse, which retains only one of the original series of five toes, correspond to members of the more generalized skeletal scheme found in the less modified mammalia. Here it is especially clear that the various limbs are *homologous*—that is, alike in their essential architecture—even though they are not *analogous*, or similar in their functional values.

THE SIGNIFICANCE OF VESTIGIAL STRUCTURES

Among the many departments of comparative anatomy, one other demands some discussion on account of the ease with which

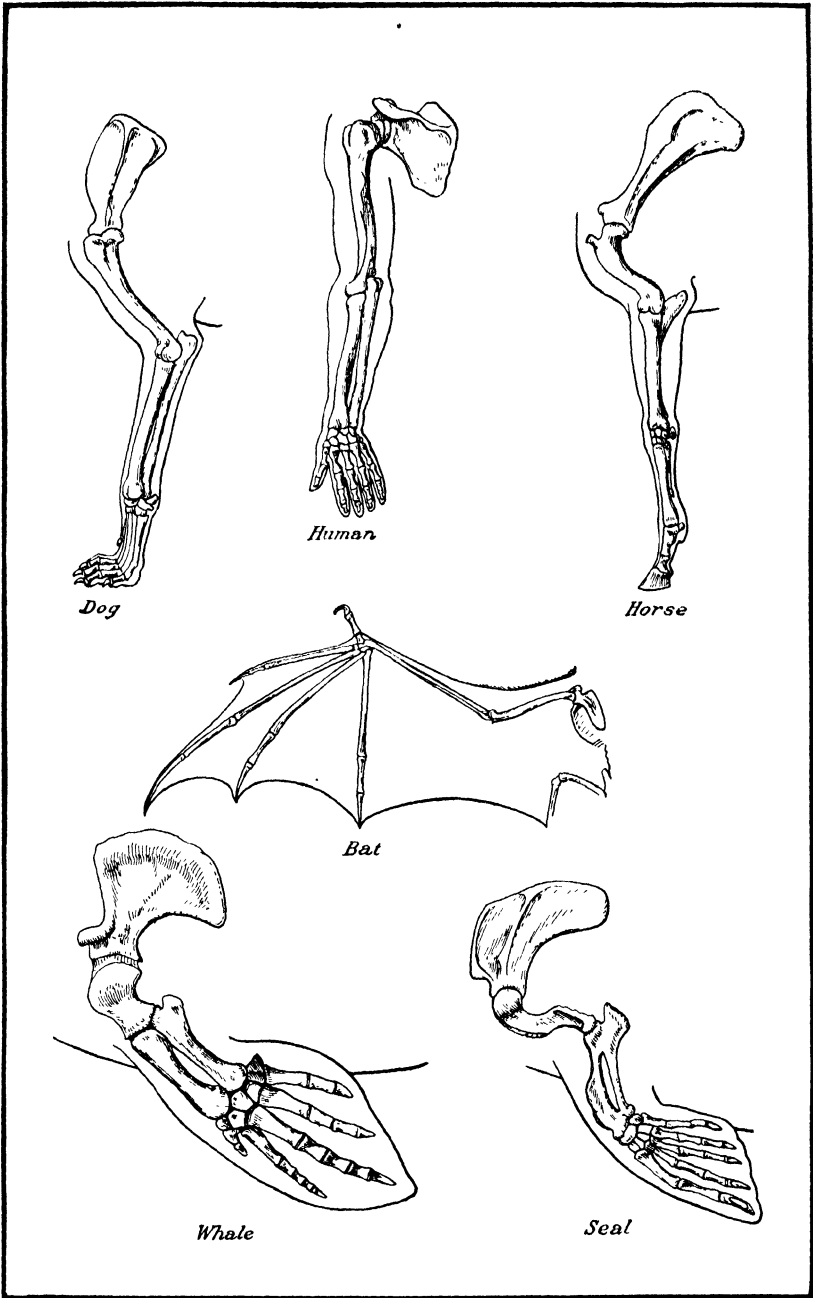

Fig. 6—ANTERIOR LIMBS OF MAMMALS

50 THE COMING AND EVOLUTION OF LIFE

the evolutionary significances may be appreciated. This division comprises the long list of rudimentary or vestigial structures. They are of no use to their possessors, and often they are positively detrimental; hence they cannot reasonably be interpreted in terms of a supernatural design or purpose. There are ample materials from which to select, for illustrations are found in abundance among many of the groups of the invertebrates as well as among the vertebrates. The so-called wingless bird of New Zealand, the apteryx, seems curiously deficient at first glance, because its tiny vestige of a wing is hidden beneath the feathers at the shoulder; this rudiment is a diminutive and useless counterpart of the wing of a flying bird, and it cannot be viewed as anything other than a product of regressive evolution from the latter kind of ancestral structure. Whales and their relatives are devoid of hind limbs, but they possess relics of what are the large and useful posterior extremities of terrestrial mammals. Whales also possess a complete coating of hair before they are born; and as hair is something which serves land mammals as a rain-shedding device, it is evident that the transitory coat of the unborn whale means an origin from an ancestor which dwelt upon the land.

VESTIGIAL STRUCTURES IN THE HUMAN ORGANISM

The human organism displays a wide variety of similar vestigial structures, and not a single organic system is devoid of them. Every human being is at one time completely covered with hairs which conform in their arrangement to those of the tree-dwelling apes. Every human individual bears a relic of a tail, consisting of three small bones at the lower end of the vertebral column. The legs of all new-born infants are curved like those of arboreal apes and their great toes, so-called, are shorter than the others and more freely movable than in childhood; all of these characters are like the features of lower primates. The effective grasping muscle of the hand of a new-born child, the reduced wisdom tooth, the appendix, the muscles of the ear, and many other things are additions to the long list of human vestigial structures which are entirely meaningless unless they are the real genetic counterparts of useful anatomical



Horse

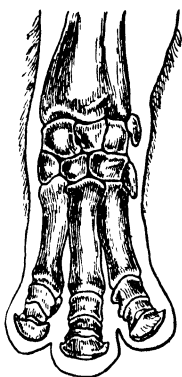

Rhinoceros

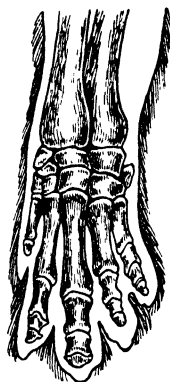

Hyrax

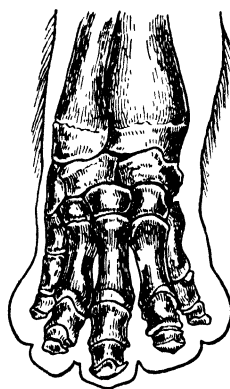

Elephant

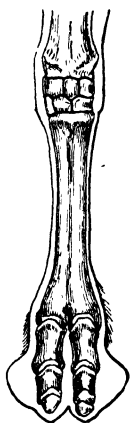

Camel



Deer



Pig

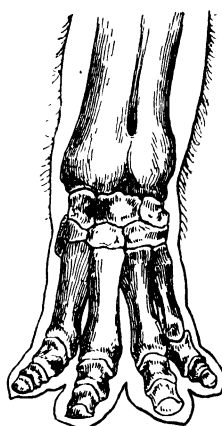

Hippopotamus

Fig. 7—LIMBS OF HOOFED MAMMALIA

52 THE COMING AND EVOLUTION OF LIFE

components of other animals. Even Aristotle was impressed by the nature of the rudimentary parts of animals, and, long before the scientific development of anatomy, he rightly interpreted them in terms of their evolutionary significance.

SUMMARY

In the foregoing paragraphs we have seen how the student of animal structure assembles his materials and how he deals with them to the end that they disclose their meanings. Whatever their differences in point of view, classification and comparative morphology are alike in so far as they are concerned with the component parts of animals and with animals considered as complete, individual types. And they are also similar in their uniform principle of interpretation of likenesses as the marks of common origins. No other explanation is reasonable in the light of our everyday experience with the succeeding generations of familiar animals, which always derive their qualities of similarity by the natural processes of biological inheritance.

CHAPTER VI

DEVELOPMENT AND EVOLUTION

NOTHING in the whole realm of animate nature makes a stronger appeal to the interest of the observer than the phenomena of *embryonic development*, and no evidences of evolution are more direct and conclusive when they are assembled and interpreted. *Every animal and every plant gains its final form by a series of transformations from simple beginnings.* If the complete organism is one of the more elaborate higher types, the changes that it undergoes are correspondingly more intricate than in the case of a simpler species, and the marvel of development is all the greater.

THE FASCINATING TASK OF EMBRYOLOGY

Knowing the make-up of the adult individual, the task of embryology is to find out how the younger stages are constructed, and how their primitive architecture becomes remodeled into the more advanced conditions of the mature stage. The facts are fascinating in themselves because they relate not only to form, but to form in the making; and they acquire a far greater value when their significances are discovered and formulated.

The most impressive lesson of comparative embryology demands full recognition at the very outset. *Developmental changes are natural and universal throughout the entire organic world.* This statement does not require argument, because its truth is demonstrated by experience. We do not know a single animal or plant that has arisen save by organic change. But evolution means simply organic change throughout long time.

Surely no one can refuse to accept the conclusion of science regarding the reality of the origin of species by structural transformation through past ages when every organism actually *does* attain its ultimate condition of complexity through developmental modification. Plants come from seeds which are certainly not

54 THE COMING AND EVOLUTION OF LIFE

plants; fowls arise from eggs which display nothing of the anatomy of the resulting bird. And the human observer himself is well aware of the profound alterations which take place as he and his kind grow from infancy through childhood to maturity. In point of fact, the very familiarity of embryonic change is perhaps the greatest difficulty to be overcome in the effort to appreciate its significance, because the phenomena are apt to be taken at their face value without any inquiry into their larger meaning.

ONLY ORGANISMS CAN CHANGE

The power to develop is clearly restricted to organisms; and however mysterious may be the whole chain of causation in its workings, yet we may be sure that this power is a concomitant of the nature of protoplasm itself, for it is not manifested by lifeless objects of simpler chemical and physical composition. Perhaps the marvel of development may to some degree be appreciated if we should imagine that its counterpart occurred in the production of inert mechanisms.

Let us suppose that a battleship originated in a parallel manner. A small mass of stuff would roll up a tube from the interior of the vessel to join with a similar product from another ship. The fused materials would enlarge, divide, and re-shape themselves into a crude elongate form, foreshadowing the outlines of the finished product. Within this mass, cavities would arise to become in time the engine-room, the corridors, and the cabins. Some of the substances would be converted into the intricate machinery for the propulsion of the vessel, some into wires, and some into electrical apparatus. Gradually the growing and diversifying materials would attain the elaborate organization and involved inter-relationships of the structures making up the finished engine of war.

Such a history of development is incredible only because it does not occur. But when the structure of any complex animal is known in larger and in lesser detail, it seems almost equally unbelievable that all of its delicate and perfectly adjusted parts could actually arise from the minute germinal beginnings of the egg. No man-made mechanism approaches in complexity any one of the familiar animals; and no machine has yet been devised

which possesses the power of the protoplasmic mechanism to regulate, repair, and maintain itself, as well as to grow and to develop.

EARLY IDEAS REGARDING DEVELOPMENT

The beginnings of comparative embryology are to be found even in the writings of some of the Greeks, and especially in those of Aristotle, who correctly described development as an actual change from simpler to more complex conditions. Harvey made one of the most important contributions to the subject when he pointed out that all organisms are produced by "somewhat similar germs," and inscribed the phrase *ex ovo omnia* (from the egg, all forms arise) on the frontispiece of his volume. But these "somewhat similar germs" were not known to Harvey or to his immediate followers as single cells. It was not until after the conception of the cell as the biological unit of the first order had been presented by Schleiden and Schwann in 1838 and 1839 that all of the component tissues of organisms including the germinal elements themselves, were shown to be only unitary masses of protoplasm with a single nucleus in each of them.

A curious interlude in the history of embryology occurred in the eighteenth century when Bonnet, Haller, and others contended that the egg was not an unorganized thing, but that it was a minute replica of the complete organism which arose from it. It was then that the word "evolution" was first employed as applied to the process of unfolding by which the excessively minute structures in the egg attained their full values. Wolff, however, who had more abundant concrete observations at his disposal, re-stated the correct views of Aristotle and Harvey in modern form; and since then development has been regarded as a process of real transformation from the unorganized to the organized, and from the simple to the complex.

At the same time that the departments of comparative anatomy and paleontology were amassing their materials and bringing them into an order which disclosed the reality of evolution, the histories of the developments of increasing numbers of animals came to be known. When these were compared, it was found that they were not individual in the sense that each species had its own way of developing. On the contrary, two

56 THE COMING AND EVOLUTION OF LIFE

forms which possessed close anatomical resemblances reached their final ends by passing through similar conditions, more and more alike as they were traced backward to earlier stages. Hence the agreements in embryonic conditions came to be interpreted in the same way as adult resemblances, namely, as evidences of common ancestry.

Furthermore, it transpired that certain characteristic stages reached and passed in the history of a higher animal were counterparts of some of the more lowly members of the morphological series. With ever increasing mass of data, it became clear that a single common principle could be formulated which stated the essential meaning of the correspondences in question. This is, *that individual history of development is a brief résumé of the primary episodes of its evolutionary production*, or, more briefly, *that ontogeny recapitulates phylogeny*. While this "law of recapitulation" cannot be taken without some qualification, yet on the whole it does embody the fundamental meaning of embryonic development, and at the same time it brings the series of stages by which an animal progresses to maturity during its lifetime into relation with the array of morphology and the sequence of terms of the fossil succession.

EMBRYOLOGY OF THE FROG

To make these matters more specific, we may review the embryology of the common frog whose natural history is familiar to everyone. The complete animal is adapted to life upon land, although it may return to water at times. It lacks the obvious tail which its salamander relatives have retained, and its hinder limbs are relatively large so that it can leap as well as walk. Like the higher terrestrial animals, it possesses lungs by which it obtains the requisite oxygen from the air. All of its organic systems are constructed upon the plans of the corresponding functional equipment of fishes, and hence the frog is deemed a more highly evolved product of evolution from some kind of ancient fish. The embryological history fully substantiates this conclusion, and it establishes others that are even more striking.

Before it finally comes out on land, the younger frog possesses a short tail which is merely a dwindled relic of the large and

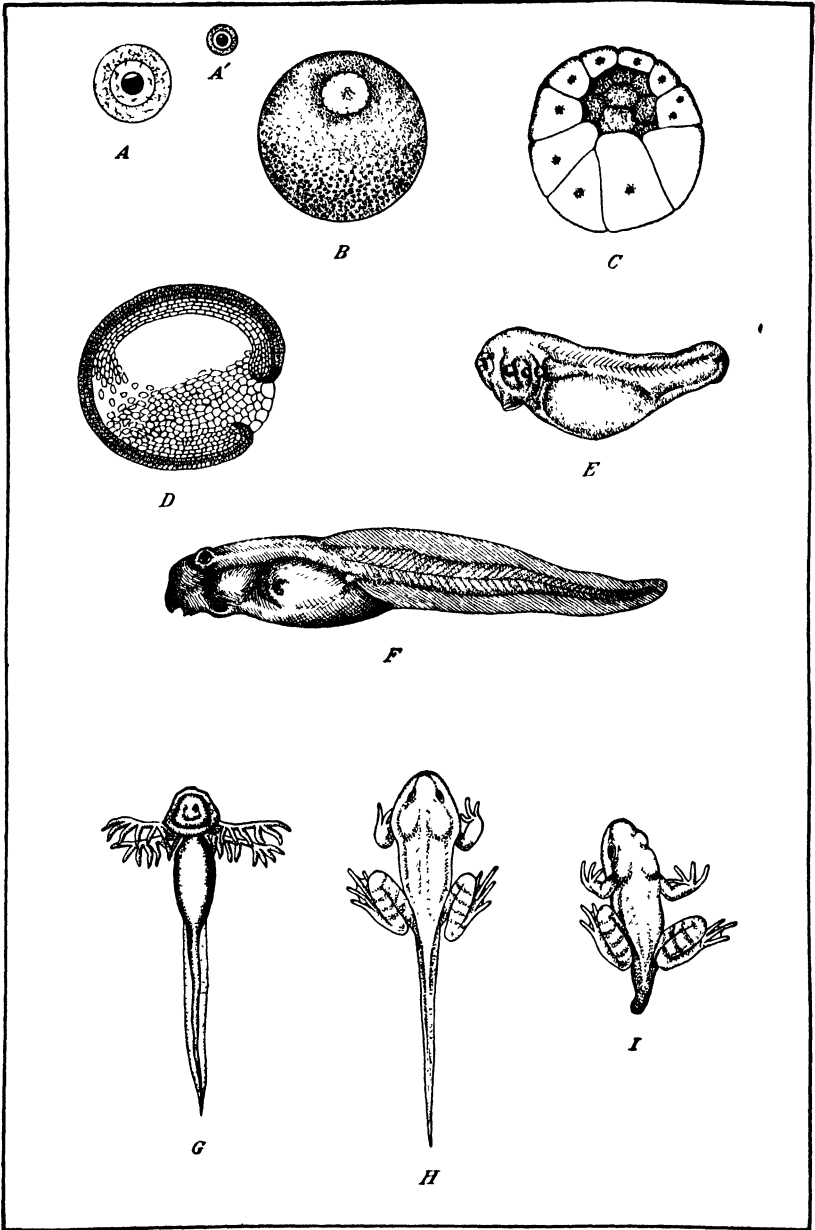

Fig. 8—STAGES IN THE DEVELOPMENT OF A FROG

A', egg, natural size, in its membrane; *A*, same, magnified; *B*, one-celled egg; *C*, early blastula, showing wall only one cell in thickness; *D*, later stage, gastrula, possessing two layers of cells; *E*, side view of embryo just before hatching; *F*, fully developed tadpole; *G*, *H*, *I*, from tadpole to frog

obvious hinder part characterizing the earlier tadpole living exclusively in water. The posterior limbs are by no means as large as they are destined to become. They and the front legs appear at a prior time, and when they are first formed they are much more like the limbs of a salamander than they are later. When the tadpole stage is organized, it is entirely devoid of lungs, instead of which it has gills that take up oxygen from the water passing into the mouth and out by gill-slits in the side walls of the pharynx. The blood is carried to the gills to be purified through a series of vessels arising from the heart. Therefore the respiratory organs and their correlated structures are essentially the same as in the fish. All of the other systems also are built more like those of the fish than like the adult structures. Here, then, is ocular proof that an organism constructed as a fish can change organically to become a true amphibian. When it does so, it shows that an origin of a modern frog from a predecessor of fish-like organization is by no means an impossibility; and it further proves that the only logical reason for the fish-like plan exhibited during the earlier stages is that it is derived by right of heredity from what the progenitor possessed.

An earlier condition of the tadpole is instructive in other ways. What becomes the digestive tract of later stages is a relatively simple tube without any well-defined differentiations. The body is devoid of the skull and the vertebral column, for these have not yet made their appearance. Instead, there is a simple, straight rod of tissue called the notochord, which serves as an axis about which the vertebrae are subsequently formed. In origin and nature, the notochord is fundamentally like the body-axis found in the primitive proto-vertebrate amphioxus.* This and the other anatomical features of the unhatched tadpole therefore point to an ancestor of the frog which was even simpler than the fish; the notochord is destined to be completely replaced by the vertebral column, and there is no reason at all for its formation other than the evolutionary one.

A prior stage displays characteristics that are still more broadly significant. The younger embryo destined to be remodeled into the simple tadpole is a two-layered sac, whose

* See Figure 4.

outer and inner walls are composed of several layers of cells—the *gastrula*. The inner tissues and their enclosed cavity later become the greater part of the digestive and respiratory systems, and they produce some of the intermediate structures as well; the outer layers form the skin and the primitive tubular axis from which the brain and spinal cord are formed. Reverting to the lower terms of the morphological array (Fig. 1) we recall the existence of two-layered animals such as the coral polyp and hydra, whose lines of ancestry were connected with those of the frog and of higher animals because, despite their differences in complexity, there were at least some organic correspondences among them all. Now comes the testimony of the frog's embryology to prove that even this elaborate animal actually does arise from an embryo whose structure is nothing more than two layers of undifferentiated cells.

Retracing the history to still earlier stages, another characteristic condition is found where the embryo is a spherical mass of cells enclosing a cavity. This is another of the critical phases of development—the *blastula*—which has a counterpart among compound unicellular organisms even lower than hydra in the morphological scale. At the very beginning, the future frog is a single cell, nothing more and nothing less. In structure, therefore, it is on the same level as the solitary protozoa that stand at the very bottom of the animal series. Although the conclusion based upon structural resemblances may seem strained when it states that the basic likenesses between one-celled animals and the frog mean an origin of the latter from an organism of unicellular nature, it receives the fullest support from the actual facts of the frog's embryology. This animal begins at the base-level of organization, and it passes into conditions similar to compound protozoa, to hydra, and still later to amphioxus and the fish, before it gains its final construction. Science can find no natural reason for the resemblances of the transitory stages in amphibian development to the anatomical plans of lower types other than an actual community of origin.

The history of development recapitulates the major ancestral conditions because heredity has preserved something of the qualities of the antecedent forms in the genealogical succession by which the frog of today has come into being. If the imaginary

60 THE COMING AND EVOLUTION OF LIFE

growth of battleships should take place in the same way, then one of the earliest stages would be a crude hollowed log—the simplest kind of craft now known. Then this canoe would enlarge, and it would form its sails, like a more improved but still primitive boat. Growing still more it would take the successive forms of a Roman galley, a medieval caraval, and a frigate. Subsequently it would discard its sails, re-organize its internal parts into engines, to become like a war-vessel of a century ago propelled by steam, in the same way that the frog replaces its gills by another kind of respiratory apparatus. And only at the end would its résumé of the evolution of ships culminate in the construction of the elaborate battleship of the present time.

A review of the embryology of vertebrates standing higher than the frog strengthens our confidence in the essential truth of the principle of recapitulation. All of the varied reptiles possess structures which at one time closely resemble those of amphioxus and the fishes. Then they pass through amphibian conditions of heart and blood-vessels, brain and gill-slits. The last named are never used as they are in younger amphibia and hence they are not explicable unless they are heritages from a water-breathing ancestor. The development of the common fowl has been the subject of most exhaustive study, because of the ease with which the various stages may be secured and investigated. Here again the embryo possesses fish-like structures which pass through amphibian and reptilian stages on their way to their avian ends.

THE SIGNIFICANCE OF MAMMALIAN EMBRYOLOGY

The mammalia are perhaps the most interesting because the human species itself finds a place within the group. The beginnings of all mammalia are single cells, on a par with the protozoa in simplicity of construction even though they are different in their hereditary capacities. The egg divides into a mass of similar cells to become what is essentially a blastula. Even the characteristic two-layered gastrula condition can be recognized, although it is not like that of the frog in its details. The embryo shapes itself into a continuous form devoid of

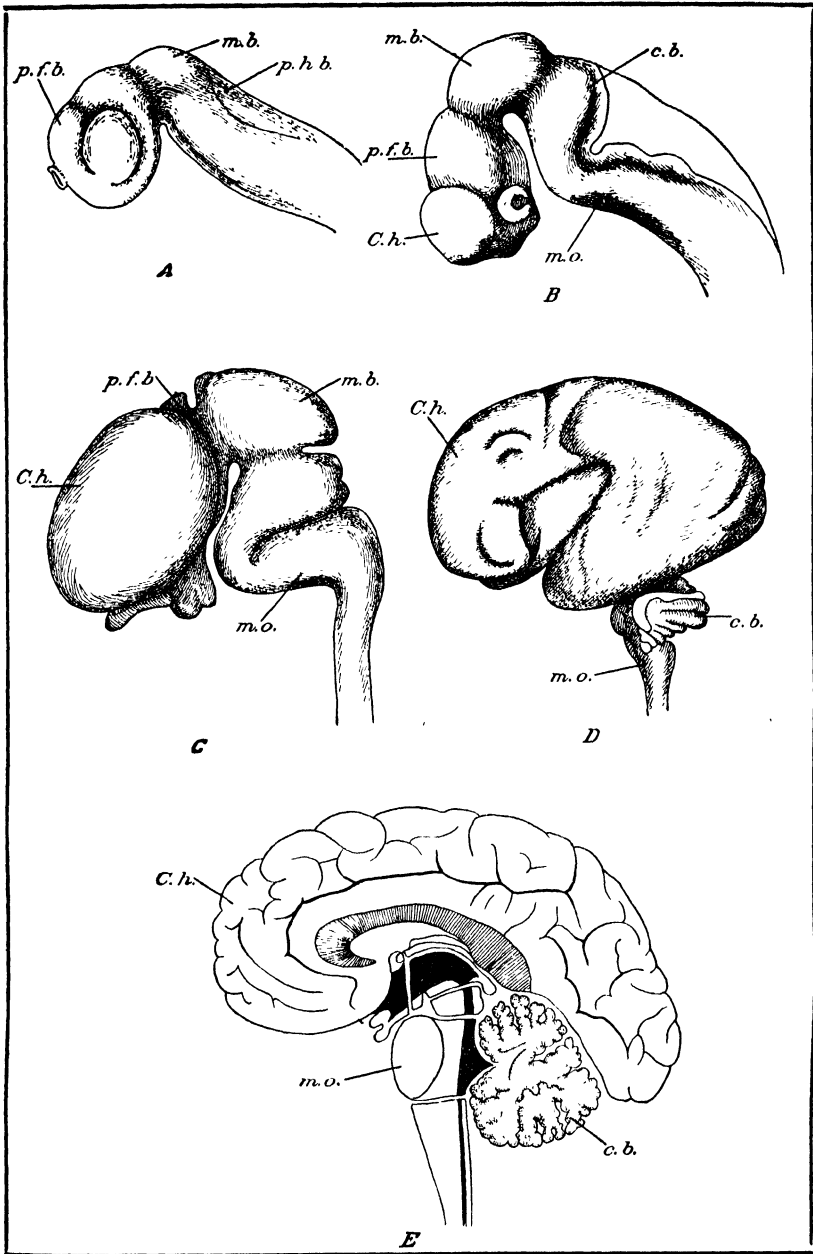

Fig. 9—STAGES IN THE DEVELOPMENT OF THE HUMAN BRAIN

A, about four weeks; B, five weeks; C, eight weeks; D, six months; E, nearly adult.
p.f.b., primary fore-brain; *m.b.*, mid-brain; *p.h.b.*, primary hind-brain; *C.h.*, cerebral hemisphere; *c.b.*, cerebellum; *m.o.*, medulla oblongata

62 THE COMING AND EVOLUTION OF LIFE

differentiation into head and trunk and tail; its further likeness to a fish is exhibited by its gill-slits, aortic trunks, simple heart, and primitive brain. All of these structures develop into counterparts of amphibian systems, and then they advance to reptilian degrees of complexity before they become truly mammalian. Each and every system conforms to this rule, in a way that is overwhelmingly significant in the case of the brain. Furthermore, the embryos of rabbits and cats and human beings resemble one another to degrees that seem extraordinary until we realize that all of these mammals have had a common ancestry; as every one of them recapitulates its history of evolutionary production, inevitably they will be alike because all pass through identical states of their common forebears.

OTHER ILLUSTRATIONS OF RECAPITULATION

Illustrations of recapitulation are to be found everywhere among the materials of comparative embryology, and they invariably corroborate the interpretations of morphology regarding relationships. Only a few specific illustrations may be cited to show how true this is.

An asymmetrical fish, like the flounder or the halibut, resembles an ordinary fish with both sides alike in the fundamental anatomy of all of its parts, and hence it is regarded as a product of evolution from a symmetrical ancestor; when it first hatches from the egg its two sides are counterparts of one another, and only later does it come to lie on one side when the lower eye actually changes in position to lie on the exposed side. Thus there is visible proof that the distorted condition in question arises by natural transformation from the more prevalent symmetrical mode of construction. Everyone knows that the adult butterfly develops from a caterpillar, whose uniform segmentation and soft skin cause it to resemble a worm; the larval stages of beetles and bees are similarly worm-like. Here the evidence of real embryonic development confirms the conclusion of comparative anatomy regarding the relationship of insects to worms. The various early stages of crabs were once interpreted as the descendants of a lobster-like animal; every crab is at one time elongated, thus proving that it is a natural possibility

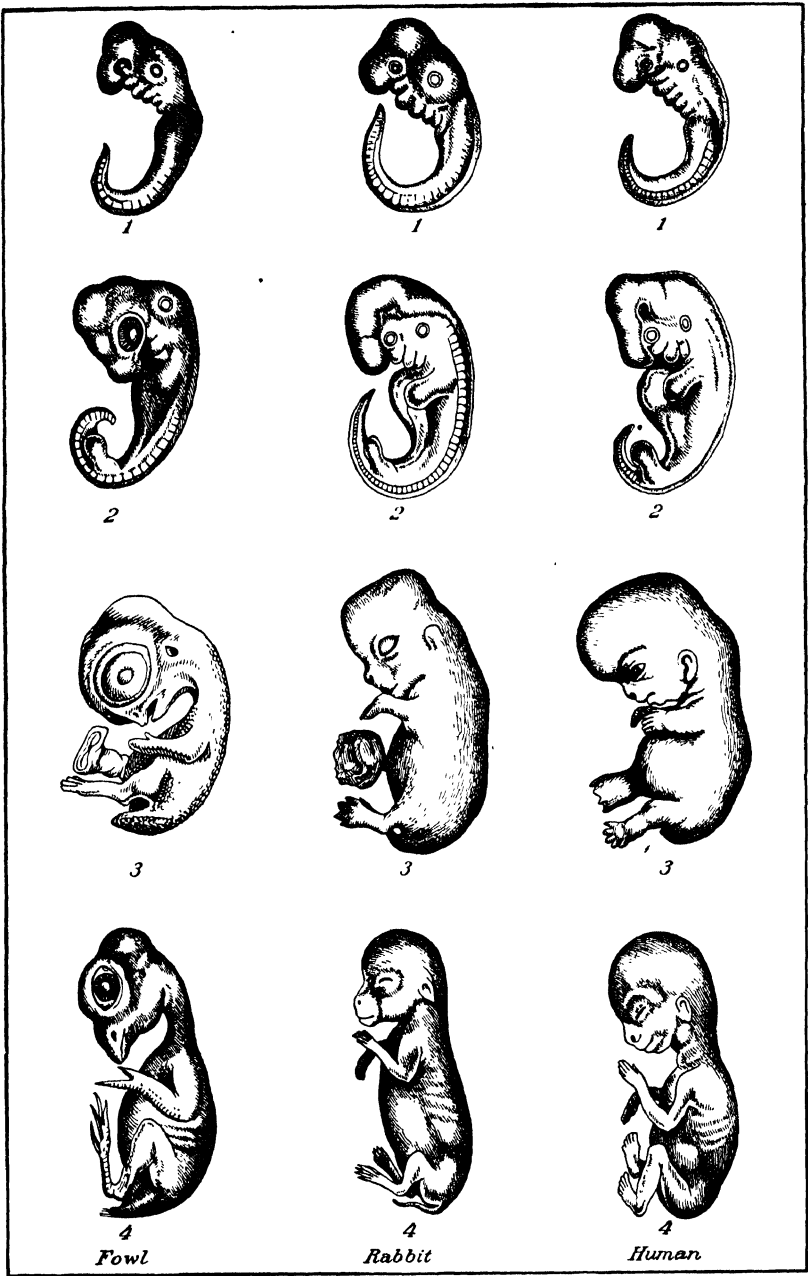

Fig. 10—FOUR STAGES IN THE DEVELOPMENT OF THE EMBRYOS OF A FOWL, A RABBIT, AND A HUMAN

64 THE COMING AND EVOLUTION OF LIFE

for an organism constructed on the plan of a lobster to change into the more differentiated condition exhibited by the crab.

All of these forms begin as single cells, and they pass through blastula and gastrula stages as well, on their several ways to their final ends. Even hydra and the jellyfish are simple blastulae before they become two-layered, and they also are single cells at the outset.

In view of the brief time available for the development of a higher animal, it is manifestly impossible for its embryonic recapitulation to include *all* of the conditions and episodes of change of its evolutionary production. The life-cycle of a fly may be only a few days, whereas a chick or a mammal may be able to fend for itself in a few weeks from the time it began as a single cell. Clearly a cat cannot *be* an actual hydra or fish or salamander or reptile, even though its architecture successively resembles all of these kinds. Hence the embryonic record of ancestral evolution is greatly condensed, and only in its essential paragraphs, so to speak, does it repeat the volume of the long-time history.

Organs do not always develop at the same rate as they have in evolution; although the caterpillar is worm-like in form and in many other respects, it has already acquired the respiratory air-tubes characteristic of insects, which no worm possesses. Thus there are anachronisms in the recapitulated record. Then, too, embryonic adaptations arise which are peculiar to a species or to a group, like the yolk-sac of reptiles, birds, and mammals, which do not mean that their common ancestor was provided with such a structure.

Embryology must learn to discriminate between those features which are really evidences of ancestral characters, the *palingenetic*, and the *cenogenetic*, which are interpolations or other alterations of the evolutionary history. When all qualifications are made, however, there remains the great truth that an organism develops along the lines of its genealogical production in time. And above all, the reality and naturalness of organic changes are demonstrated in ways which bring the results of comparative embryology to the support of the conclusions based upon the facts of morphology and of paleontology.

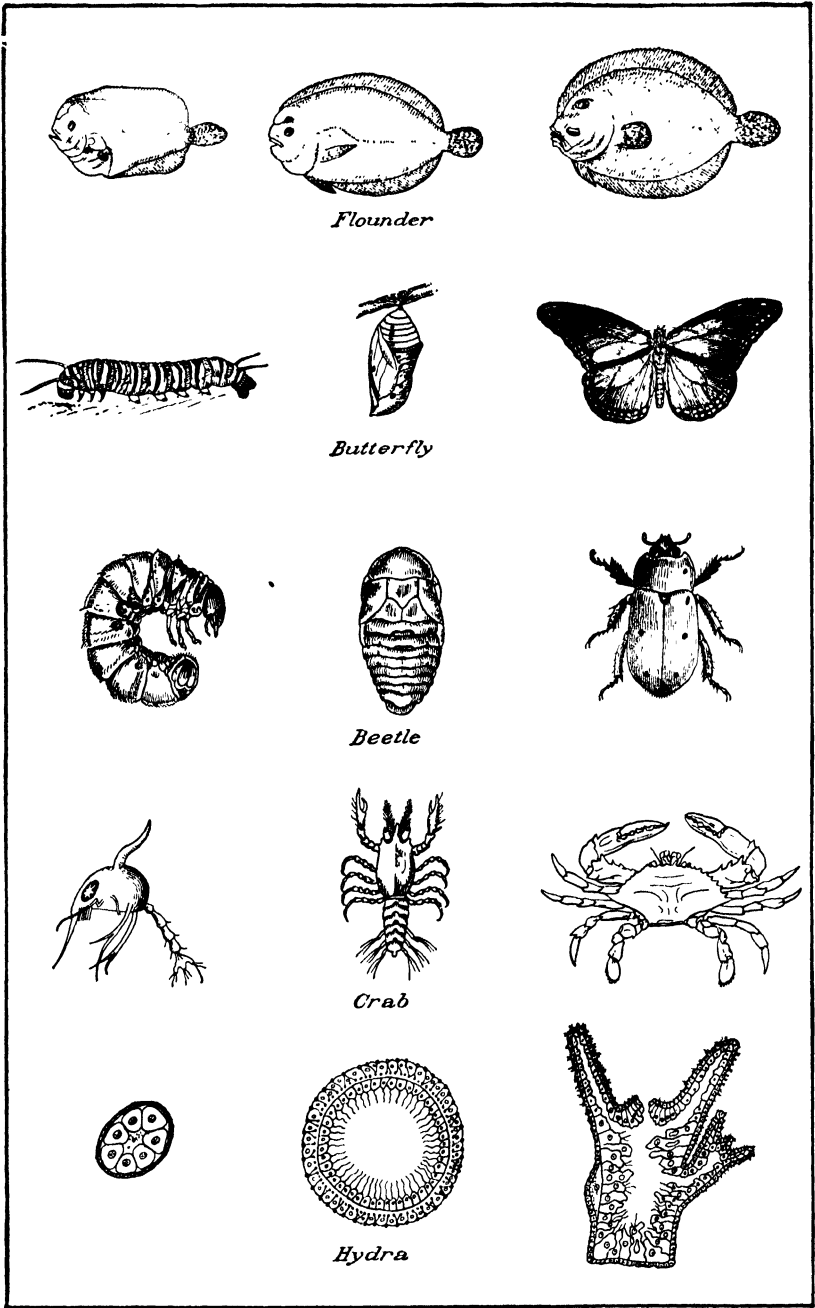

Fig. 11—ADDITIONAL SPECIAL CASES

CHAPTER VII

THE HISTORY OF FOSSIL ANIMALS*

THE third department of zoology which provides evidences of evolution is *paleontology*—the study of organisms of bygone times. As a separate volume of the present *Series* will deal with this subject, we may review it in the present connection only in a general way. The materials themselves are particularly interesting on their own merits, and their demonstration of evolution is especially clear, despite the many inherent difficulties confronting the investigator of the subject. Indeed the evidences of this category are so convincing that many regard them as sufficient in themselves to establish the evolutionary conclusion. Others, however, place equal reliance upon the interpretation of the more ample arrays of comparative morphology and upon the meaning of the unbroken series of developmental stages through which organisms pass to attain their final conditions. But, however these three bodies of proof may be estimated, all scientists are agreed that they lead to the same result, and that they give mutual support to one another in most significant ways.

THE NATURE AND MEANING OF FOSSILS

Paleontology is clearly a double subject for it comprises the facts relating to the actual relics themselves as well as the geological data required for the complete interpretation of these biological materials. The first is really morphology, in so far as the qualities of the fossils must be defined and evaluated on the basis of what the biologist knows about the structures of existing organisms.

A fragment of a mineralized bone and the imprint of a shell are not actual structures of animals but they are justly taken to represent real parts of now-extinct forms because they corre-

* See also "Fossils" in this *Series*.

spond in some degree with known components of present-day species which zoologists can dissect in their entireties. But it is not enough to assemble a series of more or less incomplete fossils. In order to understand their full meaning, the student must know about the strata of rock from which they have come, and, above all, he must know the relative ages of their geological levels. The conditions of fossilization and the processes by which strata of stone are formed and solidified must also be known. The particular place on the earth from which the fossils come is another item of importance, for horizontal distribution is quite a different thing from vertical distribution. The characters of all of the members of an associated group of relics provide additional data for their individual analysis. Thus the subject is actually far more complex than would seem to be the case when paleontology is defined in simple terms as the study of now-extinct organisms.

Although the limestone caverns of many parts of the world have yielded the skeletons of various animals including prehistoric man, it is very seldom that the real structures of organisms of more remote times are preserved in their original form and condition. Insects caught in the exuded gum of trees may be kept intact when the resin later becomes converted into amber. Two remarkable instances are known where the whole body of a mammoth was entombed in its complete form, later to be exposed by the erosion of the accumulated earth which had covered and preserved it. But for the most part, fossils are mineralized replacements of the original structures which became imbedded in silt and soil at the bottoms of ravines and lakes and oceans. The actual organic materials have completely disappeared, but infiltrating chemicals have so gradually replaced them that an adequate replica is made to give some indication of the nature of the original structural part.

OLDER VIEWS REGARDING FOSSILS

The interpretation of fossils now universally accepted is a product of relatively recent scientific analysis. The Greeks held various ideas regarding them which seem somewhat fanciful to us of the present. They were held to be mere freaks of nature, or the products of generative processes which formed them

spontaneously; and without doubt the program of organic origins proposed by Empedocles was based largely upon his observation of fragmentary fossil parts in his surroundings. Aristotle himself was a believer in their spontaneous formation. Others held that they were the remains of mythical beings such as Titans, who had left their huge bones on the field of combat—a view which had at least the merit of interpreting the things themselves as relics of creatures no longer existing in the world.

When the literal interpretation of the account of creation given in the Mosaic Scriptures was adopted in later medieval centuries, the time accepted for the existence of the world was too brief to allow for the natural work of the slow geological processes of rock formation and fossil embedding, although Leonardo da Vinci and Nicolaus Steno held the correct views even in those days. It became necessary to regard the relics in question as things which had never been parts of living animals but as supernatural productions of a fragmentary nature, put in the rocks to puzzle the students of nature and to lead them astray in their efforts to understand them. Or else they were explained as the remains of living creatures drowned by the traditional flood described in the Scriptures.

THE MODERN INTERPRETATION

The definite organization of paleontology* came about mainly as the result of the labors of Cuvier and Lamarck. The first great naturalist dealt principally with the vertebrates, carrying over to the growing body of materials of fossil nature the principles of comparative morphology whose form and substance were developed by himself. Lamarck concerned himself with the series of extinct invertebrates and brought them into their proper sequence. Cuvier, however, was a vigorous opponent of the idea of evolution for which Lamarck was then contending, and it is a curious circumstance that the naturalist who organized comparative anatomy and who exerted so great an influence upon the development of paleontology was himself a believer in special creation.

Cuvier was impressed by the correspondence in general plans

* See "The Earth" in this *Series*.

exhibited by the groups of fossils from older to later times and to the species of the present. He believed that the Creator had employed four architypal schemes, so to speak, in constructing the vertebrates, molusca, jointed animals, and radiates. The first crude varieties of these plans were supposed to have perished as the result of an extensive cataclysm, after which new species were again supernaturally created after the same general models but different and more elaborate in their details of structure. Successive disasters and repeated acts of supernatural creation of analogous character brought the four series to their modern representations.

Meanwhile, however, the English geologists Smith and Lyell were developing a naturalistic formula for the evolution of the components of the earth's crust. The strata of rock were brought into an order of their formation and consequently their enclosed fossils were arrayed in a sequence from the older to the later. Above all, the forces which now operate to make new layers of rock were shown to be all that were required for the construction of the more ancient levels, provided only that such natural influences worked in the past as they do today. The correct doctrine of "uniformitarianism" is usually associated with the name of Lyell, and it came to be universally accepted in place of the cataclysmic hypothesis of Cuvier because it gave an explanation of geological evolution in terms of entirely natural causation.

THE UNIQUE VALUE OF FOSSIL EVIDENCE

The evidence for evolution provided by fossils cannot be overvalued because it is *direct* proof that animals and plants *have been different* in successive geological ages. The morphological array of animals from low to high discloses evolution by the intellectual act of *interpretation*; embryology gives immediate evidence of the reality of organic transformation as well as an explanation of the particular transitional stages in development in terms of an ancestral history of production recapitulated in the life-history of a modern type; but the terms of the fossil series are the *actual items* of a genealogical succession which has worked its way upward during the incon-

70 THE COMING AND EVOLUTION OF LIFE

ceivably long ages required for the massive layers of the sedimentary rocks.

The strength of paleontology is by no means impaired by a due recognition of the difficulties to be encountered in its work. When animals are reviewed, whole classes and phyla are found where there are no hard parts capable of resisting disintegration long enough to be replaced and petrified; hence their ancient progenitors will ever be unknown. The conditions for fossilization are such that few among the myriads of animals existing in a by-gone period could possibly be preserved. As a rule, only those rocks which lie at or near the surface, in accessible regions of the earth, will yield their fossil contents to the seeker, even if all other circumstances are favorable.

Older strata, lifted to the heights, are eroded and destroyed to form the deposits of later times, and any animal remains they may have contained are inevitably disintegrated with them. Thus it is that the full sequences of the lines leading to modern species can never be completed; and they must always be less adequate than the phyletic series of existing animals arranged in their morphological order of classification, while their fragmentary nature is even more evident when it is contrasted with the unbroken succession of stages presented in a single embryonic record.

In order that the full value of the evidence of fossils may be appreciated, a purely geological task must first be accomplished. This involves the arrangement of all of the sedimentary rocks in the order of their construction so that the relative ages of the various strata may be determined. It is not essential to know exactly how much time was required for the formation of any one of them or of them all, although there are methods by which an approximate result may be obtained.

It is possible to measure the amount of the annual deposit of sand and silt at the mouth of a great river, as well as the chemical substances carried in solution. When an older rock is found which consists of identical materials in solidified condition, its thickness gives an indication of the length of time necessary for its construction. Another formula is employed by the physicists which takes into account the rate of radiation of the earth's heat, and which allows for new increments of heat

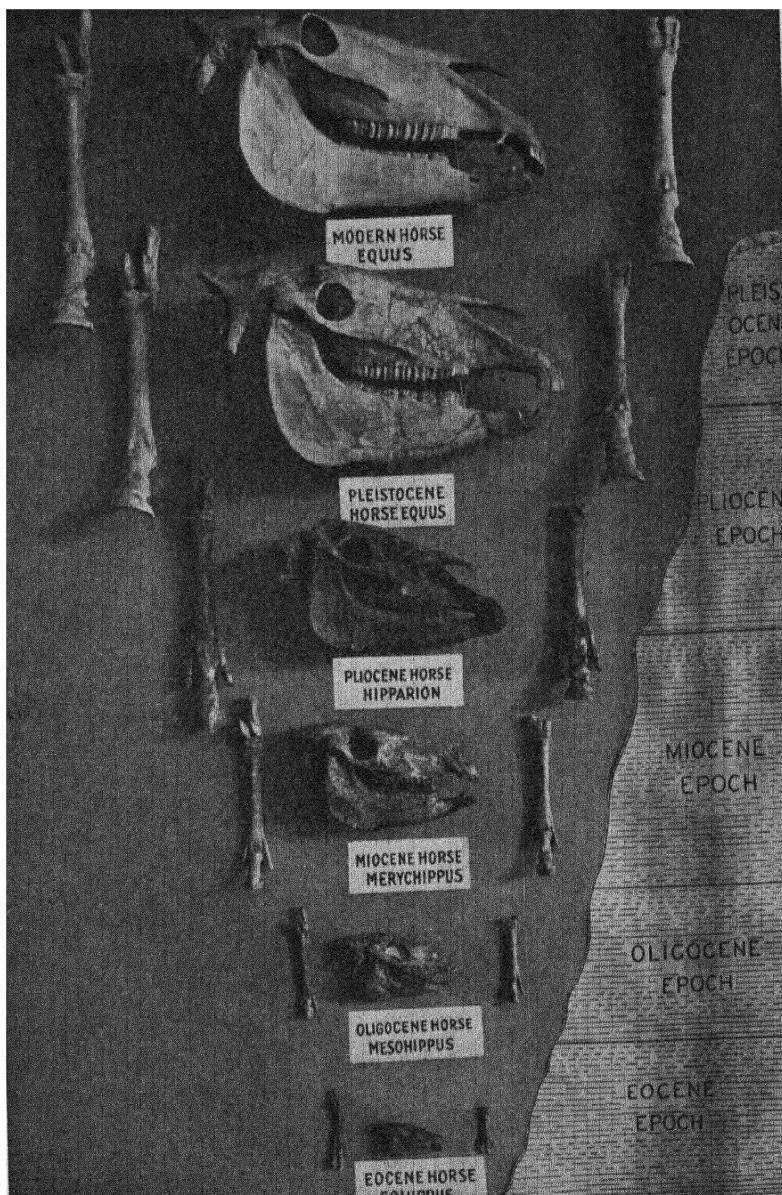

Hind foot Skull Fore foot Geologic succession

Fig. 12—THE EVOLUTION OF THE HORSE

through the breaking down of radioactive substances. But the data of geology themselves are perhaps more sure, and they show that approximately 1800 millions of years have elapsed since the age when the first primitive organisms came into existence.

ARRAYING FOSSILS IN THEIR TIME-ORDER

Historical geology begins its work with a series of superimposed strata exposed upon a mountain side or upon the walls of a chasm such as the Grand Canyon. It requires nothing but common sense to decide that the deeper layers are older than the upper ones. Many of the items of one exposure may be found at another locality with other layers above or below them, and consequently the additional elements of the series can be given their proper places in the time-order. The work of correlating the strata of rock of widely separated areas goes forward by the same logical methods, until all are brought into a consecutive series. This entire series would have a thickness of approximately 100 miles. But evidently it is impossible for all of its components to appear in any one place, because the rocks of a later age are formed in the lower valleys and basins out of materials provided by the more ancient layers which are then constituting the uplands.

When all of the strata of sedimentary nature are brought together in an order of their construction, it becomes possible to assign relative ages to the organisms whose remains are found in one and another of them, with entire confidence that these organisms lived during the older or later times when the rocks were formed. At once the dramatic meaning of these relics becomes apparent.

The very oldest strata are entirely devoid of animal remains, and hence their era is denominated the *Azoic*. Then come the *Archeozoic* and *Proterozoic* eras, so-called because the entombed fossils prove that the animals of their times were primitive in their construction. With the *Paleozoic* era more advanced types of invertebrate animals appear, and for the first time backboneed animals come into being in the form of fishes. Not until later does the next class of vertebrates—the amphibia—establish itself. Then follows the era when reptiles flourished in extraordinary numbers and variety; this period is called the

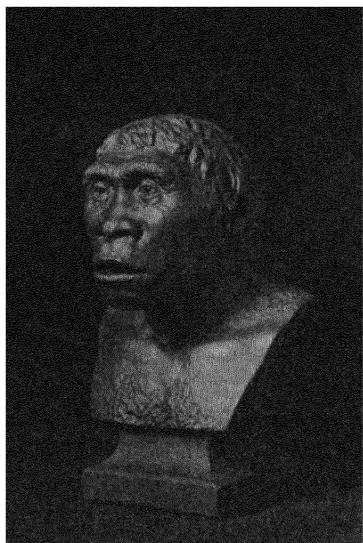

The Java "Ape-Man"
Pithecanthropus erectus

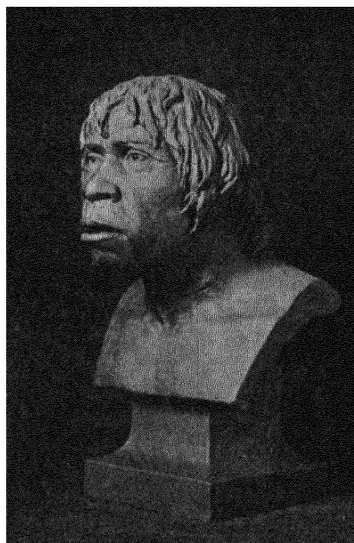

The Piltdown Man
Eoanthropus dawsoni

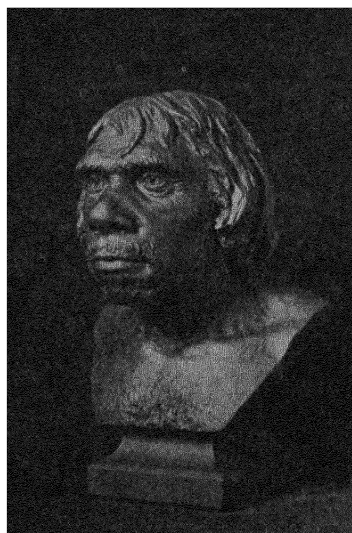

The Neanderthal Man
Homo neanderthalensis



The Crô-Magnon Man
Homo sapiens

Fig. 13—HUMAN FOSSILS

These restorations in the American Museum of Natural History were made by Dr. James Howard McGregor and are modeled on restored skulls

74 THE COMING AND EVOLUTION OF LIFE

Mesozoic, or Middle Animal Age. Only in the upper end of the whole series of rocks do birds and mammals make their appearance; and as these forms approach the forms existing today, this late era is named the *Cenozoic*, or Recent Animal Era. It must always be borne in mind that the work of arranging the strata in their time-order is accomplished solely on the basis of geological facts. The types of animals and plants are then placed in the order of their appearance upon the earth, and it is only for convenience that the geological ages are named according to the characteristics of their enclosed fossils. This convention is often misunderstood by those who are unfamiliar with paleontology and who imagine that the rocks of various ages are placed in a sequence according to their fossil contents; on the contrary, the organic remains are dated by their strata.

CONCLUSIONS FROM THE FACTS

The main general conclusion drawn from the facts of paleontology is that the larger and lesser groups of animals have come into being in exactly the same order which comparative morphology establishes as the order of evolution. The lower forms devoid of backbones come before any vertebrates appear. The latter arise in an anatomical sequence from lower fishes to higher mammals in complete correspondence with the series of developmental conditions by which an adult mammal attains its final distinctive qualities. Thus paleontology supports the conclusions drawn from the other categories of evidence, with all of the unique strength inherent in and peculiar to its own materials.

Many a chapter of the later fossil record gives the approximate history of some of our existing species in a form which falls short of completeness, it is true, but which comprises details of convincing significance. Our one-toed horse is explained by comparative anatomy as a product of an ancestor with more toes on each foot; the fossil record confirms this interpretation in so far as the more ancient horse-like animals possess more toes as we go backward in time. Prehistoric man-like types are progressively more similar to the apes when again the record is followed to its earlier items, such as the Neanderthal examples

and the still more striking *Pithecanthropus*, found in Java, with its clear intermediacy in structure between the true apes and modern mankind; and here again the parallel between the terms of the fragmentary fossil sequence and critical stages in human development is demonstrated.

The foregoing brief outline may suffice to indicate what fossils are and how they are interpreted with the aid of sure geological knowledge. Incomplete as they may be, yet they prove the reality of natural evolution in a logical and convincing manner. Without evolution, they are meaningless.

CHAPTER VIII

THE NATURAL PROCESSES OF EVOLUTION

HAVING concluded the review of the evidences of organic evolution, we now come to the engrossing problems of evolutionary dynamics, or what causes evolution to take place. Hitherto we have put aside all queries concerning the factors of the process in order that the proofs of natural descent might be examined on their merits. The result is the conviction that the various kinds of animals are intelligible only as the products of accumulating and diverging variations; every item of knowledge of every department of zoology serves as proof in one connection or another, and *there is not a single discordant or contradictory fact in the whole wide range of the subject.* Because these things are true, we may go forward with the confident expectation that we can discover the agencies which are working at the present time in such ways as to bring about evolution. Although we may not hope to find the answers to all of the questions we might ask, at least we can discern the immediate factors in processes that are commonplaces of everyday experience. The problem, in brief, is to discover what goes on before us which will serve to explain the long-time history of natural changes by which all of the diverse species of living things have gained their present conditions.

THE PROCESS OF EVOLUTION EVERYWHERE THE SAME

It is helpful to realize at the outset that living nature is essentially the same throughout its entire range in certain fundamental qualities. All organisms agree in protoplasmic make-up, in cellular constitution, and in physiological abilities for the purpose of individual maintenance and for the perpetuation of their kinds. Therefore we are predisposed to accept the statement of biology that the process of evolution is everywhere the same for all kinds of organisms.

Natural evolution is essentially *one* process, and not something that varies from one organism to another; and what may be learned in the case of any particular species or group of species may be employed for the analysis of the history of other organisms.

ADAPTATION A UNIVERSAL FEATURE

All animals and all plants, however diverse they may be, agree in one outstanding characteristic, and they are also alike in so far as their ever-recurring generations display two processes. The universal feature of all organisms is *adaptation*, to which attention has so often been directed in the foregoing pages; the universal processes are *variation* and *heredity*. These things are obvious to every one, and they are natural in the sense that they are the attributes of all living things. They are the subjects of central importance, for when they are understood and accounted for, the dynamics of evolution become intelligible in large measure.

Adaptation is a truism of experience. The existing kinds of organisms are so constructed as to meet the various conditions of life successfully, each with its own individual shape and with its own combination of organs. This being so, the question as to the origin of *species* becomes the inquiry into the *origin of adaptations* of various kinds: a natural explanation of the one serves also for the other.

VARIATION AND HEREDITY

Variation is the word employed for the universal biological phenomenon of organic diversity. While it would be legitimate to apply it in a broad sense to the larger degrees of difference exhibited by species within their genera, and by genera within their more inclusive groupings, the term is conventionally used more narrowly in two connections.

The individual members of a single generation, with identical parents, are said to exhibit variation because no two of them are ever alike in all details. No one individual is exactly similar to either of its parents, and hence variation has a second connotation in connection with parent-offspring differences. The point of greatest importance is already clear, namely, *that a natural*

78 THE COMING AND EVOLUTION OF LIFE

process goes on universally in such ways as to produce some details of diversity in the case of every single organism. This is the first essential of evolution, and its causes are to be distinguished as *primary factors*. The problem of science is to discover the material reasons for biological variation of the elementary degree of parent-offspring difference. But even without any information as to its machinery, the reality of natural causation is evident from its effects.

The process of biological inheritance is quite as obvious as the foregoing. Like produces like, even if perfect resemblance is never to be found, and there is always variation. Here, again, the task is to discover the concrete mechanism by which the greater numbers of parental qualities are carried over so that they are manifested by offspring as they were by their progenitors. And again the fact requires full recognition that the continuity of characters is real and natural throughout the organic world. The responsible factors of this process are termed *secondary*.

Even in the early times of the Greeks, the naturalists who gained some conception of the reality of evolution endeavored to describe the procedure of nature in terms of variation and heredity, and stated that organisms attained their individual conditions by adaptation. The program of Aristotle is circumstantial in part, in so far as it gives prominence to the modification of structure induced by the surrounding influences of the environment; but it is also to some extent mystical, for the whole history of an organism's production was supposed to be controlled by a "perfecting principle" which guided the events of evolutionary change to their adaptive end.

BUFFON, ERASMUS DARWIN, AND LAMARCK

With the modern development of zoology and botany, the problems of evolutionary dynamics were taken up on the basis of far more complete knowledge. Yet the views put forward during the pre-Darwinian period were little more than re-statements of those of remoter times. Buffon was strongly impressed by the way that plants varied under the direct influence of environmental conditions, like light and shade, moisture and dry-

ness, and the mineral content of the soil. Convinced that evolution had been accomplished by the accumulation of small individual variations and finding organic diversities coming about readily by the immediate action of the environment, he supposed that these were transmitted to offspring along with all of the bulk of their hereditary qualities which presumably had been acquired in the same way at earlier times.

But his supposition is in fact merely an assumption; it is evident that environmental influences are primary factors of *variation*, but it does not necessarily follow that they are primary factors of *evolution*, for there is no proof that their effects are passed on to offspring.

Erasmus Darwin and Lamarck added a second category of primary factors of variation, *i.e.*, the functional, but they made the same error in supposing that the effects of the influences in question were inherited. Lamarck developed his views much more completely, and hence the theory of the "transmission of acquired characters" is usually credited to him. With Buffon, Lamarck contended that the evolution of plants was largely accounted for by the inheritance of responsive changes to directly acting environmental influences, but he denied the like in animals. Like Erasmus Darwin, he held that external circumstances cause animals to react differently, that they form changed habits of response, and that they alter in bodily characters owing to their different reactions. Then follows the same gratuitous assumption of the other authors, to the effect that the results of use and disuse are inherited.

Working out the theory in a general form, it would be necessary to regard all of the basic characters to which the newer ones are supposed to be added as the products of still earlier environmental inductions. We need not discuss the inherent difficulties of this view at the present juncture, but it must be pointed out that while environmental and functional influences may sometimes induce bodily variations, they cannot be regarded as primary factors of evolution unless some reasons for believing that their effects are transmitted can be discovered. No such reasons have been found, and the principles of Charles Darwin, confirmed and extended by later investigation, have given a far truer explanation of the whole course of evolution.

THE INVALUABLE WORK OF CHARLES DARWIN

While we must not underestimate the value of Darwin's work in organizing and clarifying the evidences as to the reality of evolution, his greater service consisted in his elucidation of evolutionary procedure. His *Origin of Species* and later volumes are largely concerned with the central topics of adaptation, variation, and inheritance; and they present the formula, properly called Darwinism, which is a complete and comprehensive program of natural evolution. All of its terms are obvious, and it is necessary only to bring them together to realize their efficacy. Stated in full, Darwin's scheme is the "natural selection of congenital variations"; even when it is more briefly called "natural selection" it carries the connotation of the overwhelming value of innate or constitutional factors of variation as contrasted with environmental and functional causes of diversity.

The first point is that all organisms in all of their parts are adapted to the conditions of their lives, whether they are simple or complex, and whether they dwell in the same or in different situations. One and the same environment, like a millpond, may be the home of frogs and turtles and fish and snails and worms and lesser creatures, which in their various ways are able to carry on with success all of the several activities demanded of an organism. As we have seen, the problem of the origin of their individual distinctions is the problem of the establishment of their various adaptations.

HOW OFFSPRING DIFFER

The next element is the indispensable requisite of evolution, *i.e.*, *variation*. While the attention of his predecessors had focused on diversities induced by external influences, produced either directly or indirectly, Darwin rightly attributed far higher value to the innate or congenital causes of change. Without denying the reality of "acquired" alterations, he pointed out that all kinds of differences of various degrees are displayed by the offspring of the same parents, even under identical surroundings and even before the organisms engage in active life. However the congenital factors may operate, and whatever their

material nature may be, they demonstrate their reality by their manifest effects in the way of fortuitous deviations from the conditions of the parents. Others beside Darwin had come to realize the importance of the primary factors of this category, notably Alfred Russel Wallace, Herbert Spencer, and Patrick Mathew; but Darwin emphasized their value far more than anyone else, and he brought them into the discussion of a subsequent part of the whole formula in a most effective way.

OVERPRODUCTION AND SURVIVAL OF THE FITTEST

Another natural phenomenon throughout the organic world is overproduction. All animals and plants multiply at such a rate that it is manifestly impossible for all of their offspring to arrive at maturity, although it requires some effort to appreciate the truth of the matter because so few in each generation fulfill their biological destinies, and it is only these that we see.

If an annual plant produced the small number of two seeds, and if every seed should grow into a plant which in its turn formed two seeds, without any loss whatever, the resulting offspring in the twenty-fourth generation would number 16,777,216. A female conger eel lays 15,000,000 eggs in one season; allowing for the bisexual nature of the resulting fish, and assuming that all might survive to become parents, the third generation would include more than 843 million million eels. Even the tiny protozoa multiply in such a way that if all of the descendants of a single individual should live throughout a period of five years, their protoplasmic mass would be thousands of times greater than the earth in bulk. Clearly all cannot survive, nature being what it is. Accidents of various kinds progressively decimate the swarms of growing young. Above all, however, animals are under the necessity of replenishing their substance with other protoplasm; this means that, if they are to reach the adult condition, they must capture and kill and eat some other kinds of organisms if their superior abilities enable them to do so, and, too, they must evade still other animals to whom they would serve as nourishment.

A rare parasite is known which gives birth to 300,000,000 young in one generation; if only a single member of this huge

82 THE COMING AND EVOLUTION OF LIFE

family reaches maturity, the position of the species in nature would be maintained for the time, but the other millions would have perished because they had failed to meet successfully one or another condition of survival. We see only the small numbers of the survivors of any species, and we are too prone to forget the countless others which have begun life only to perish.

Therefore, as a consequence of biological overproduction, all organisms are engaged throughout their lives in an incessant and many sided struggle for existence, which ends inevitably with death as the penalty for failure in one essential or another. The seeds of plants fail to receive sufficient sunlight or moisture. Extreme degrees of heat and cold destroy quantities of plants and animals; and even the human species suffers from such agencies of the inorganic environment. The incessant warfare of species with species more truly deserves the name of a struggle for existence. Fishes and protozoa and all other animals do not increase at the rates noted above, because they all have enemies which prey upon them. Powerful as they are, human beings are by no means the victors always, as we know only too well. In India alone the victims of snakes, tigers, and other enemies number about twenty thousand annually. In one campaign against humanity waged in the year 1918 by the hordes of the infinitesimal bacteria of influenza, the recorded human casualties amounted to more than thirty millions. And the conflict in nature's gladiatorial arena is rendered even more intense by competition among the members of even a single species, for they are all seeking identical means of subsistence which will not suffice for them all.

The teeming hordes of contestants upon the battlefield of nature are not alike in their equipment, because the congenital factors of their qualities have made them different. Inevitably the most unfit will be slain first, to be followed by others whose endowments may enable them to prolong the contest for a time. But gradually and inevitably, the numbers of every kind will diminish until only the best will be left alive to discharge their reproductive obligations. In brief, the elimination of the greater majority of the unfit results in the survival of the fittest, pitifully small in numbers as compared with the others.

Although favoring circumstances may prolong the life of a

weakling beyond what it might have been, and while an efficient animal may meet an early death by misfortune, yet on the whole those which have failed are condemned by their congenital heritage, and, more clearly, the few individuals which survive to adult maturity must be the ones whose innate qualities conferred success. It is not essential that they shall be perfect, but they must be adequate, and they must not possess any characteristic which is detrimental. At once the universal condition of organic adaptation is accounted for, because there are no unadapted; all kinds of variants are produced with each generation, but the inefficient disappear so as to leave the world to only those which prove themselves competent.

In this way, Darwinism explains a universal feature of all living things in terms of purely *natural causation*, and without recourse to the mystical principle by which Aristotle and his philosophical followers have sought to account for adaptation.

INHERITANCE

The last element of the formula concerns itself with *inheritance*. Natural selection is really a process of "trial and error" on a universal scale throughout the organic world. The primary factors of congenital change provide the multifarious variations that are subjected to the tests of their capabilities, and only those which are predestined to survive by their heritages can do so. It is true that environment and function may induce changes, but only if the hereditary equipment is of such a nature that this is possible. Thus the natural selection of the fittest is really a process by which congenital factors of fitness are selected on the basis of the qualities which they determine.

These factors are already innate and heritable, and so the natural course of inheritance carries them over to the offspring. But the hereditary machinery so works that the parental fitnesses are never perpetuated exactly, and congenital variation comes about again, with the result that the following generation must be subjected in its turn to the same process of selection on the part of the natural conditions of life.

Clearly, then, congenital variation and congenital continuity are the most important elements of Darwin's whole formula.

Concentrating upon these phenomena, biological investigators of later decades have been able to learn much about the material machinery causing them, thereby increasing and strengthening our confidence in the truth of Darwin's program of evolutionary procedure.

THE FACTS OF ARTIFICIAL SELECTION

The results attained by the breeders of domesticated animals and plants were fully assembled by Darwin to support his doctrine of natural selection at large; these constitute the subject of *artificial selection*, so called on account of the human direction of the destinies of the organisms in question. The term must not, however, be taken to imply anything unnatural, for, on the contrary, the breeder simply avails himself of the purely natural biological processes that go forward in his materials precisely as they do under wild conditions. All are familiar with the different hereditary types of domestic fowls, varying in size and plumage, color and fertility, and even in temperament as in the case of the pugnacious game-fowl. Yet they have all come from the same wild ancestor whose like still exists in the forests of oriental countries. While the varieties of dogs may have had several different origins from the wolf and other canine forms, many of them have certainly arisen from identical progenitors. The hound, collie, toy terrier, and bulldog, are sufficient illustrations to show how different are the results, and how many classes of characters have been affected in their evolutionary production.

The breeder finds that the offspring of these animals are hereditarily unlike; he cannot keep them all, and so he eliminates those which do not meet his need or fancy. The selected individuals transmit their heritages to their descendants, though always with some further variations owing to the behavior of the hereditary mechanism. Thus the human director avails himself of the natural processes that are universal in all organisms, merely substituting his choice for what wild nature demands in the way of general competence. Despite some minor errors of interpretation made by Darwin, he rightly adduced the facts of artificial selection to confirm the essential contentions in his

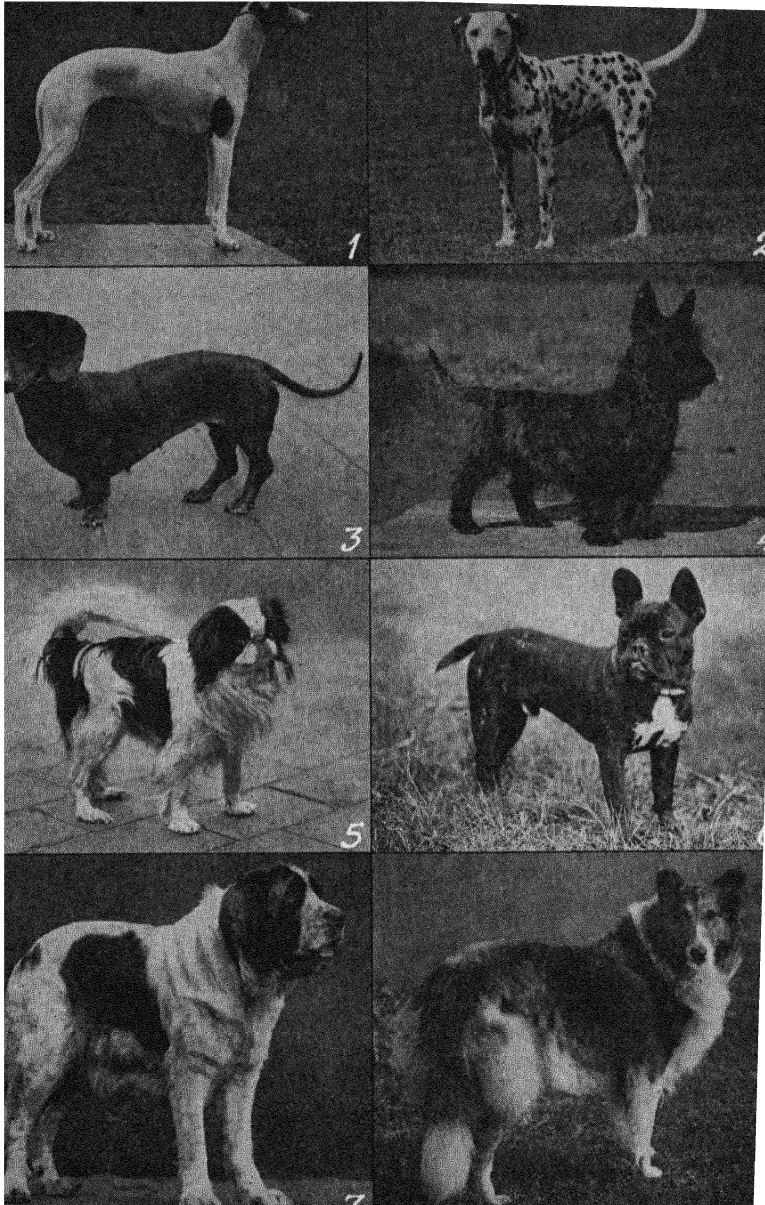

Fig. 14—VARIETIES OF DOGS

1, greyhound; 2, dalmatian; 3, dachshund; 4, Scottish terrier; 5, Japanese spaniel;
6, French bull terrier; 7, St. Bernard; 8, collie

all-inclusive theory of the natural selection of congenital variations.

SEXUAL SELECTION

Many have expressed considerable scepticism concerning the value of the facts of *sexual selection* which Darwin also cited as confirmatory evidence of the truth of his views, but there can be no doubt that many special characters of difference between the two sexes serve as the choice of a mate by the one or the other. In general there are more males than females, and hence the former are involved in a kind of competition. The selection of a mate by the female bird of paradise actually seems to depend upon the greater excellence of the song or the plumage of a male. In human experience it is everywhere evident that the different qualities of the one sex serve to attract or to repel the other. The characters themselves are congenital in causation, and hence the process of sexual selection is entirely analogous in all of its elements to artificial selection and to the more inclusive procedure of natural selection.

The effects of Darwin's work were immediate and widespread. Students of organic nature were stimulated to amplify the masses of zoological fact and to bring them into an order which more clearly revealed their values as evidences of evolution. The belief in the reality of natural evolution gained far wider acceptance as the result of Darwin's demonstration of the methods by which the process is accomplished.

MODERN INVESTIGATION OF THE FACTORS OF EVOLUTION

For a time, naturalists were considerably occupied with controversy concerning many of the major and minor elements of the doctrine of natural selection, but soon their attention returned to renewed investigation of biological fact, in an effort to gain a fuller and more analytical understanding of the processes at work. It was obvious that the central problems were those of biological inheritance, with its dual accomplishments of perpetuating qualities at the same time that it brought about transmissible differences. Researches on heredity came to be organized in three departments: investigation of the actual

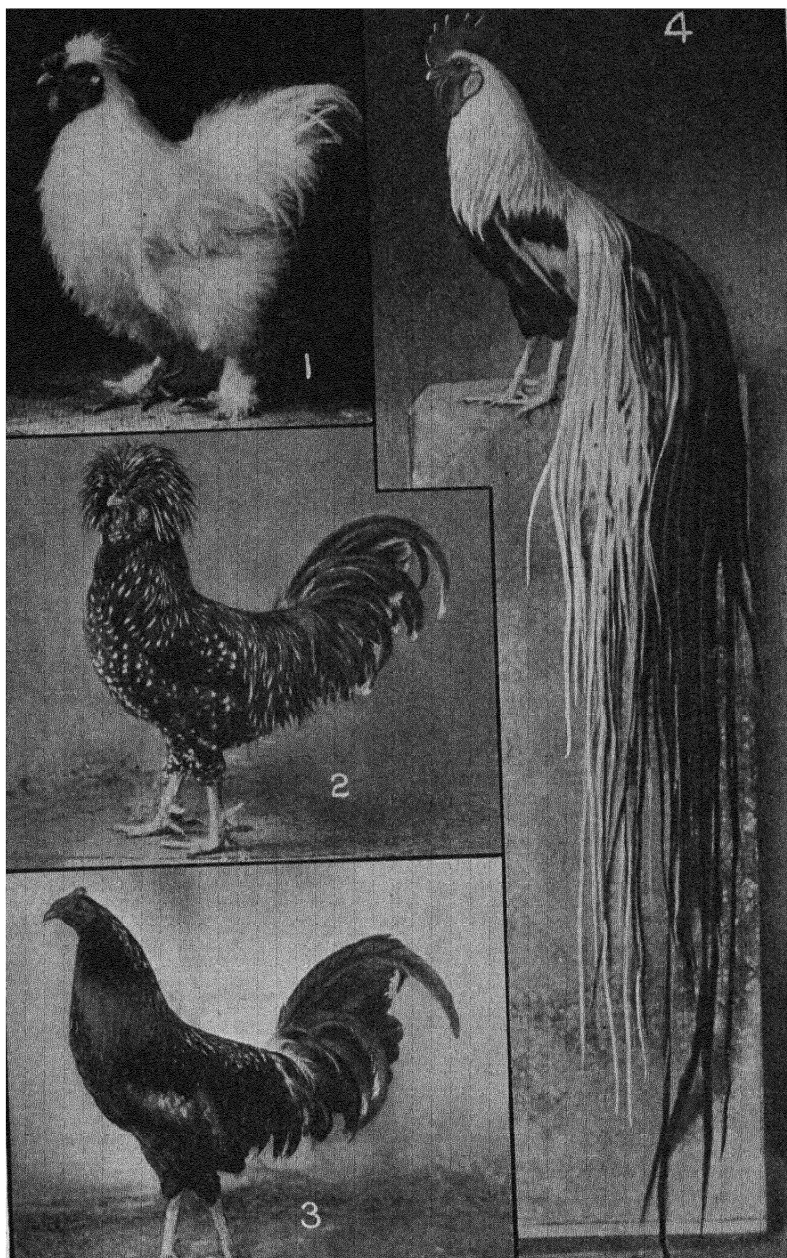

Fig. 15—VARIETIES OF FOWLS
1, Silky; 2, Houdan; 3, Game; 4, Long-tail

physical basis of inheritance, experimental breeding, and statistical studies of variation. The last has been able to accomplish much by describing the course of hereditary variations in the mass, but the behavior of particular qualities through a succession of generations is a matter of *individual* history, and this becomes obscured when the data are treated collectively.

The greatest advances have been made in the other fields, each of which at first developed in entire independence of the other, until in 1900 it became evident that their results were mutually explanatory and confirmatory. The product of their union is the subject with the new name of *genetics*, which comprises all biological knowledge of heredity whatever its nature and source. A separate volume of this *Series** will deal with heredity, and hence the discussion at this point will include only so much of an outline as may be necessary in order that the concluding sections of this chapter will be intelligible.

THE PHYSICAL BASIS OF HEREDITY

With the establishment of the cell doctrine, and the proof that all cells come from pre-existing cells throughout the ever-recurring life-cycles of organisms, research was directed to the discovery of specific constituents of these biological units which would fulfill the requirements of a physical basis of heredity. Darwin himself, as well as others of his time, postulated the existence of such constituents as a theoretical necessity. The outstanding figure in this field of research is the German zoologist, August Weismann, who identified the specific substance in question with the peculiar deeply staining bodies in nuclei, the so-called *chromosomes*. Like the cells themselves, the chromosomes pass on through one division after another in unbroken genealogical succession. The closest attention was focused on the germ cells and upon the one-celled egg formed by their union which is destined to produce by division all of the resulting cells making up the mature individual. These germ cells are the only physical links between parents and offspring, between ancestry and posterity. What they are, how they are related to the parental bodies, and how they contain the poten-

* "Heredity and Variation."

tialities of the differentiated organisms coming from them are the great problems.

The re-appearance of qualities throughout successive generations is explained as the result of an unbroken continuity of the chromosomal basis of heredity, the germ-plasm. That the chromatin is indeed the seat of the factors which determine organic qualities is demonstrated most clearly by the fact that the male germ cells, the sperm, is little more than an animated nucleus, whose cytoplasmic accompaniments are almost infinitesimal as compared with those of the female gamete, the ovum. The nuclei of the two gametes come together to form the single nucleus of the egg, or zygote. As paternal heredity is sensibly equivalent to maternal heredity and as the only physical equality is nuclear, it follows that the chromosomes are the actual bearers of the heritage.

Furthermore, the stream of germ-plasm is directly continuous from the initial zygote to each and to every part of the body in general, or soma; and equally direct in its course to the genital organ, the gonad. The latter is in no sense manufactured by the body in which it lies, although we speak as though this were so when we say that a hen produces germ cells. The soma does not form the eggs any more than the gonad participates in the construction of the somatic parts, such as the head or the heart. The cells of the gonad are liberated, and the germ-plasm they contain is therefore able to induce a character in the offspring like that which the parent body displayed. The procedure in question is illustrated in simplified form in Figure 16, so as to show how the continuity of the germ-plasm stream provides for the re-manifestation of characters in succeeding generations.

The cause for congenital variation appears when the biparental origin of the zygote is brought into the scheme (Fig. 16). Each germinal nucleus brings its own set of chromosomes to the egg; as it carries qualities which are different from those of the other gamete, the resulting mixture of chromosomes will be different from what each contributed, and the mature soma must be unlike the body of either parent. Throughout the longer period of development, all of the chromosomes are equally distributed to the multitudes of cells of the soma and of the gonad

as well. Then comes a brief, but very important process of assortment of the paternal and maternal chromosomes resident in the gonad cells, and as a result the one or the other of each pair is eliminated.

The chromosomal pairs behave independently at this critical episode of maturation, and thousands and millions of different combinations of these bodies can come about in the individual germ cells from one and the same parental gonad. Congenital variation is the inevitable outcome; some of the original factors are sure to be retained, when the characters they determine will re-appear in the offspring, while others will be lost with equal certainty. In brief, the chromosomes fulfill all of the requirements of a physical basis of biological inheritance; and their different modes of behavior at fertilization, during development, and at maturation, account for the two obvious processes of continuity of characters, when these are repeated in the next generation, and of discontinuity, or congenital variation, as well. It is admitted that the explanation of the latter phenomenon is not as complete as in the case of the former; but other modes of chromosomal workings are known, such as mutation, or the spontaneous production of a new quality, which supplement the program which we have outlined above, and which support the conclusion that the chromosomes are the bearers of heritable characteristics.

The story of the classic work of Gregor Mendel, its independent confirmation in 1900 by De Vries, Correns, and Tschermak, and its amazing extension since that year, belongs to the volume, "Heredity and Variation" in this *Series*. It is sufficient to state here that the behavior of qualities in the course of generations of plants and animals under experimental control, in thousands of cases has given the clearest proof that the chromosomal machinery discovered by the cytologists works in the ways that have been described. Even the distinctive condition of the one or the other sex can be referred not merely to *some* chromosome among those present in the nucleus but to *particular* members which can be visibly distinguished. A still greater achievement has been the demonstration that the factor responsible for a special character can be located with more or less surety at a particular point in an identified chromosome.

Thus the processes of congenital continuity and congenital variation, no more real now that their causation is known than they were to Darwin, are explained in terms of the nature and workings of a distinguishable, concrete, protoplasmic basis.

THE RELATIVE VALUES OF HEREDITY AND ENVIRONMENT

At the last, we come to the age-old problem of the relative values of heredity and environment. In contrast with the decades of the past century, this problem can be discussed today on the basis of abundant concrete facts derived from cytological studies and actual experimentation. The problem comprises two distinct propositions. In the first place we may ask what are the relative values of heredity and environment in determining the qualities of an individual organism, and secondly what are their values in the course of evolution. As to the first, the answer is that heredity provides the *qualities* of an animal or of a plant, whereas the rôle of any other factor is limited to a *quantitative* influence upon the expression or suppression of the characters which are themselves fully determined in kind by the heritage; and incidentally it is clear that by no means all characters are capable of any modification whatsoever by external circumstances or by functional re-action. If a handful of barley and wheat and oats were cast to the winds, the grains would fall upon poor or average or very good soil, and they would grow into poor or average or well-developed plants according to the nature of the environment. But adverse conditions would not cause any of them to become other than what its heritage determined in the way of barley or wheat or oats, nor would favorable circumstances make them different in quality from what their innate congenital equipment would direct.

The answer to the second question is that changes of an individual's body induced by external influences, or "acquired characters" in the proper sense, are not inherited. The evidences for this conclusion are abundant and universal. In the first place, the workings of the germ-plasm are such that no channel exists for the introduction of bodily effects into the germinal stream; if such there were, then the procedure would be what is shown in Figure 16. But the real relations between gonad and soma,

92 THE COMING AND EVOLUTION OF LIFE

indicated in Figure 16, A and B, exclude the possibility of the transmission of bodily alterations. Mendelian phenomena of inheritance relegate the environment to a negligible rôle so far as concerns the congenital natures of the offspring produced by hybridized individuals. Fraternal twins among human beings do not resemble one another to greater degrees as they grow up under identical environments, while identical twins, which bear the same hereditary factors, retain their resemblances even when they live separate lives under diverse conditions.*

Experiments carried on by mankind without any knowledge of the scientific value of the results have never yielded a single positive case of inheritance of acquired characters. The tails of terriers have been cut and the tails and manes of horses have been cropped for many generations, and yet there are no hereditary effects of these successive mutilations. Various human races have induced changes on their own bodies for thousands of years in some cases, like the binding of the feet among some of the Chinese; but the course of hereditary transmission of the normal character has not been influenced to any degree.

When investigators have made the same kind of experiment, with full recognition of the scientific points at issue, the results are equally negative. Weismann cut off the tails of mice, bred them, and repeated the treatment for twenty-two successive generations, without any diminution of the size of the tail at the end of the experiment. Mice have been trained in various ways and their offspring have been tested to see if the new accomplishments of the parents had been passed on, but always with the same negative result. It would seem hardly necessary to try this kind of experiment when it is already known that whatever learning a human being acquires is never conferred upon his descendants, although the powers of a brain capable of gaining knowledge are heritable.

The last resort of the environmentalists is the supposed transmission of maternal impressions, and then only in the case of the mammals where the relations between the developing embryo and the maternal body are intimate to the extent that the former derives its nourishment from the latter. The student of embryology knows, however, that no cells actually pass from

* See "Heredity and Variation" in this *Series*.

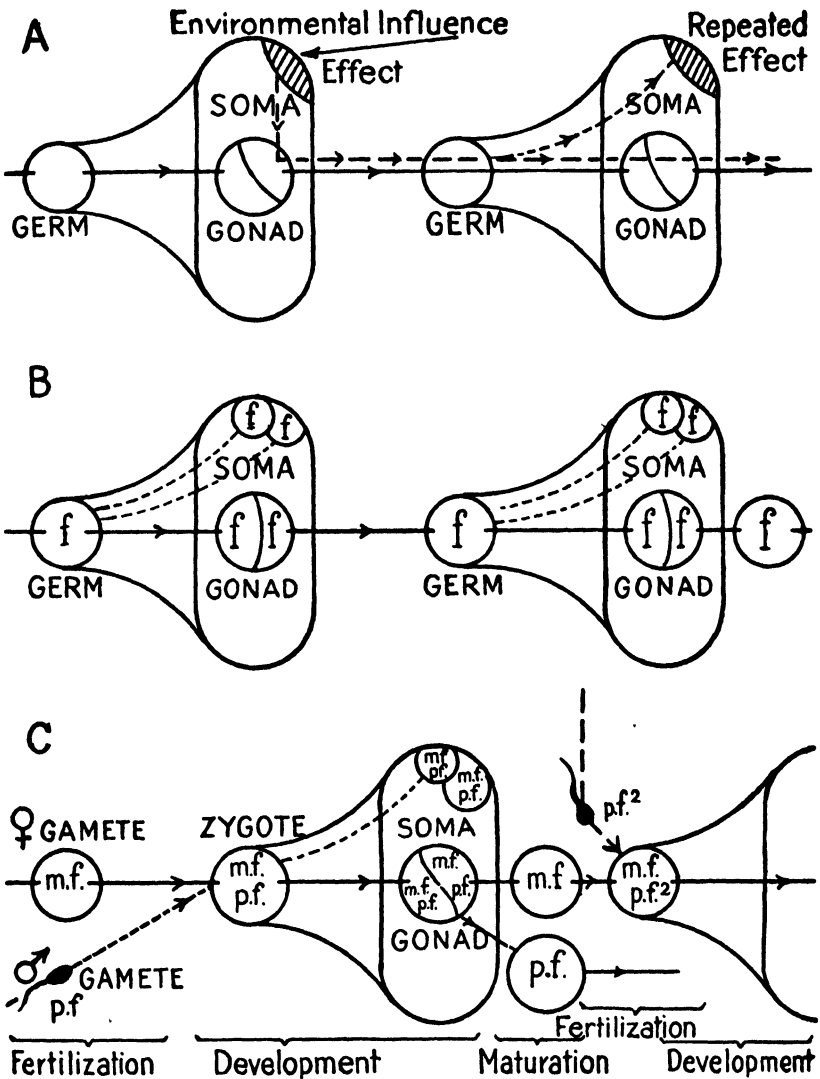

Fig. 16—THE COURSE OF INHERITANCE

A, simplified diagram showing the fallacy of the transmission of acquired characteristics; B, simplified diagram showing the continuity of the germ-plasm; C, full scheme, showing biparental formation of the zygote, and segregation at maturation. *f*, germ-plasm factor; *m.f.*, maternal congenital factor; *p.f.*, paternal congenital factor; *p.f.²*, second congenital factor

94 THE COMING AND EVOLUTION OF LIFE

mother to child, and that no way exists by which an effect exerted upon the maternal body can enter into the young individual. All supposed cases of pre-natal influence fail to stand the test when the principles of anatomy and inheritance are applied. Here, too, actual experiments have been performed, with a negative result. In 1891 Walter Heape mated white angora rabbits, and a growing embryo in its earliest stages was taken out of its natural mother and transplanted into the proper situation in a gray, short-haired female. The embryo was born with long and white hair, without any trace of the contrasted qualities of its foster-parent. William Ernest Castle and John Charles Phillips transplanted the entire female genital organ of a black guinea-pig into the body of a white animal; when this female was mated with a white male, the offspring of three successive litters were black, thus proving the strength of the germ-plasm on the transplanted organ and the absence of any qualifying effect on the part of the new maternal environment.

The entire body of evidence of whatever source overwhelmingly proves the superior value of the innate factors of organic qualities; and it allows to the environment the power to induce somatic changes to a limited extent, if at all. Even if acquired modifications do arise, and even if they are induced generation after generation, there is no proof whatsoever that they can enter into the heritage of the kind. All of the discoveries up to the present time have thus corroborated the essential tenets of Darwin's formula of the dynamics of evolution, *i.e.*, the natural selection of congenital characteristics. With abundant material evidences of nature's workings in evolution, the conclusion that evolution is a real process throughout the organic world is rendered sure and unassailable.

SUGGESTIONS FOR FURTHER READING

Prepared by the Editors

- DOCTRINE OF EVOLUTION**—*Henry E. Crampton* COLUMBIA
A very full and complete statement of the case by the author of the present volume.
- ORIGIN OF SPECIES**—*Charles R. Darwin* (Many editions)
The book that gave a mighty impulse to the study of biology.
- WHY WE BEHAVE LIKE HUMAN BEINGS**—*George A. Dorsey* HARPER
Accounting for human beings and their behavior. The story of man—his life and evolution—dealing with origins, vital processes, causes, results in an infinite variety of ways of practical interest to every person interested in life and its problems.
- LIVING ORGANISMS**—*Edwin Stephen Goodrich* OXFORD
An introduction to modern biology, discussing in a broad way the nature of life, processes of heredity, and the foundations of the evolutionary theory. Good for those who have some general knowledge of the subject.
- STREAM OF LIFE**—*Julian Sorrell Hurley* HARPER
A readable book of 63 pages in the *Things-to-Know Series* discussing the facts of biology that bear upon human evolution, heredity, environment, etc., pleading for a reasonable eugenics as the hope for future betterment.
- EVOLUTION**—*Vernon L. Kellogg* APPLETON
A popular and very readable account of the history and evidences of evolution.
- EVOLUTION**—*John Graham Kerr* MACMILLAN
In this outline of evolution the author has restricted himself to the animal kingdom. The book is written for beginners who will find the author's reasoning easy to follow and understand.
- PROBLEMS OF EVOLUTION**—*Arthur Ward Lindsey* MACMILLAN
A non-partisan discussion of existing evolutionary theories.
- EVOLUTION AND CREATION**—*Sir Oliver Joseph Lodge* DORAN
A somewhat speculative but stimulating book for the thoughtful reader who wishes an exposition of cosmic evolution discussing religion and science. The author views creation as a continuous process eventuating in the evolution of the human being with spiritual possibilities.
- WAYS OF LIFE**—*Richard Swann Lull* HARPER
An excellent book for the layman who wishes a clear, concise statement of the scientific data relating to the evidences of evolution and the origin and history of living things. The deductions are carefully made and are quite understandable by the non-scientific reader.
- EVOLUTION IN SCIENCE AND RELIGION**—*R. A. Milliken* YALE
Written by one of America's ablest scientists of interest to those interested in spiritual verities.
- GIST OF EVOLUTION**—*H. H. Newman* MACMILLAN
- PURPOSIVE EVOLUTION**—*Edmund Noble* HOLT
A speculative study designed to show a purposive design in nature, to offer a solution, and to resolve the supposed conflict between science and religion.
- FROM THE GREEKS TO DARWIN**—*Henry Fairfield Osborn* SCRIBNER
A scholarly and authoritative study of the whole history and development of the idea of evolution through many centuries down to the present day. A book for the layman as well as the scholar.
- WHAT EVOLUTION IS**—*George Howard Parker* HARVARD
Clear, fair, and interesting. An outline of the historical development of the modern idea of evolution in contrast with special creation as an explanation of existing life.
- CONCERNING EVOLUTION**—*J. Arthur Thomson* YALE
Three lectures delivered at Yale University. The author states that his object as "to show that evolutionist description is not inconsistent with religious interpretation." Not in popular vein but well worth reading.
- GOSPEL OF EVOLUTION**—*J. Arthur Thomson* PUTNAM
Dr. Thomson's writings are noted for their charming style and lucidity. He is one of the best interpreters of science writing today.

96 SUGGESTIONS FOR FURTHER READING

EVOLUTION FOR JOHN DOE—*Henshaw Ward*

BOBBS

A general account of organic evolution. An exposition of the evolution doctrine written expressly for the laymen unacquainted with biology who desires to understand the problems of life.

KEY TO PUBLISHERS

- APPLETON—D. Appleton & Company, 29-35 West 32nd Street, New York, N. Y.
BOBBS—Bobbs-Merrill Company, 724 North Meridian Street, Indianapolis, Ind.
COLUMBIA—Columbia University Press, 2960 Broadway, New York, N. Y.
DORAN—Doubleday, Doran & Company, Garden City, N. Y.
HARPER—Harper & Brothers, 49 East 33rd Street, New York, N. Y.
HARVARD—Harvard University Press, Randall Hall, Cambridge, Mass.
HOLT—Henry Holt & Company, Inc., 1 Park Avenue, New York, N. Y.
MACMILLAN—The Macmillan Company, 60 Fifth Avenue, New York, N. Y.
OXFORD—Oxford University Press, 114 Fifth Avenue, New York, N. Y.
PUTNAM—G. F. Putnam's Sons, 2-6 West 45th Street, New York, N. Y.
SCRIBNER'S—Charles Scribner's Sons, 597 Fifth Avenue, New York, N. Y.
YALE—Yale University Press, 143 Elm Street, New Haven, Connecticut.

GLOSSARY

[Only those terms are defined in this glossary which either are not explained in the text or are explained once and are used again several pages away from the explanation.]

CONGENITAL VARIATION: a deviation, existing at birth, in structure or function from the usual type or parental form.

EMBRYOLOGY: the branch of biology which relates to the formation and development of animals and plants.

MORPHOLOGY: the branch of biology dealing with the structure of animals and plants.

PHYLUM (*plural* phyla): one of the primary divisions of the animal or vegetable kingdom, so called because the members are assumed to have a common descent.

VESTIGIAL STRUCTURES: a small degenerate or imperfectly developed part or organ which has been more fully developed in an earlier stage of the individual.

AUTHORITIES CONSULTED IN MAKING ILLUSTRATIONS

- Figure 1—Chandler, Leavitt, Martin, Parker and Haswell, Scott, Stedman, and Trafton.
- Figure 2—Amie, Century Dictionary, Jordan and Heath, Ridpath, Scott, Steele, Tenney, and Vanity Fair.
- Figure 3—Chandler, Jordan and Heath, Martin, Peabody and Hunt, Scott, Steele, Tenney, and Trafton.
- Figure 6—Romanes.
- Figure 7—Romanes.
- Figure 8—Kellicott, Morgan, Newman, and Parker and Haswell.
- Figure 9—Cunningham.
- Figure 10—Hackel, Parker and Haswell, Lull, and Romanes.
- Figure 11—Jordan and Heath, Jordan and Kellogg, Riley, Scott, and Trafton.

INDEX

WITH PRONUNCIATIONS †

- Adaptation**: and organisms, 6; essential in evolution, 20; a universal feature of organisms, 77
- Africa**, 23
- Aldrovandi** (äl-drö-vän'dē), Ulisse (1522-1605), an Italian naturalist, 31
- Alimentary apparatus**: and animal functions, 7; of vertebrates, 44
- Alimentation**, 44
- Ameba**: cells of, 9*; relation to other invertebrates, 41*
- Amphioxus** (äm'fī-ök'sūs): primitive form, 58; relation to other vertebrates, 39*
- Anabolism**, 12
- Analogous limbs**, 48
- Anaxagoras** (än'äk-säg'ō-rās), (ca. 500-428 B.C.), Greek philosopher 29
- Anaximander** (än-äk'sī-män'-dēr), (ca. 611-547 B.C.), a Greek physical philosopher, 27
- Ancestral characters**, 64
- Animals**: functions of, 7; identical nature of, 43; organic systems of, 44; of pre-historic eras, 72; products of natural changes, 22; resemblances, 38; structure of, 37
- Anthropomorphism**, 29
- Ape**, 39*
- Apteryx** (äp'tēr-īks), 50
- Aquinas** (ä-kwī'nās), Thomas, Saint (1225?-1274?), an Italian scholastic teacher, 30
- Arcella**, 9*
- Archeozoic** (är'kê-ō-zō'ik) era, 72
- Aristotle** (är'is-tōt'1), (384-322 B.C.), a Greek philosopher and teacher: as a naturalist, 27; the baneful effect of his intellectual domination, 29; his description of development, 55; his interpretation of rudimentary parts, 50; his idea of fossils, 68; and evolution, 20, 78
- Arthropoda**, 42
- † For key to pronunciation, see page 103.
* Asterisk denotes illustration.
- Artificial selection**: explained, 84; and Darwin's theory, 35
- Augustine, Saint** (354-430 A.D.), a Numidian bishop, 30
- Azoic era**, 72
- Azores Islands**, 23
- Bacon, Francis** (1561-1626), an English philosopher, 30
- Bat**, 49*
- Bio-chemistry**, 14
- Biological inheritance**, 38
- Biological paradox**, 12
- Biological unit**, 55
- Biology**: defined, 1; our study of, 5; and the origin of living matter, 13
- Birds**, 40
- Blastula**, 59
- Bonnet** (bo-nä'), Charles (1720-1793), a Swiss naturalist and philosophical writer, 55
- Botany**, 32
- Brains**: of humans, 61*; of vertebrates, 45*, 46
- Bruno** (bröön'ō), Giordano (1548-1600), an Italian philosopher, 30
- Buffon** (büf'ün), Comte de (1707-1788), a French naturalist: and evolution, 33; and evolutionary dynamics, 35; and environmental influences, 78; and Lamarck, 34; and the Lamarckian hypothesis, 28
- Butterfly**, 65*
- Camel**, 51*
- Carbohydrates**, 11
- Castle, William Ernest** (1867-), an American zoologist, 94
- Caucasian**, 38
- Cells**: as the biological unit, 8, 55, 9*
- Cell-doctrine**, 32
- Cenogenetic** (sē'nō-jê-nët'ik), 64
- Cenozoic era**, 74
- Chromosomes**, 88
- Circulation**, 7
- Class distinctions**, 40
- Classification**: in the study of zoology, 37; conclusions of, 43; and analogous interpretation, 42
- Collie**, 85*

100 THE COMING AND EVOLUTION OF LIFE

- Comparative anatomy: what it is, 37; department of, organized, 32; interpretation of, 44
- Congenital continuity, 91
- Congenital variation: defined, 91; cause for, 89; exponents of the theory, 81; Darwin's emphasis of, 35; and Darwinism, 80
- Conger eels, 81
- Contractile muscles, 8
- Co-ordination, 7
- Correns, Karl (1864-), a German botanist, 90
- Cosmic evolution, 17
- Crab, 65*
- Cuvier (kü"vyä'), Georges (1769-1832), a French naturalist: and comparative anatomy, 32; and the development of paleontology, 68
- Cytoplasm, 8
- Dachshund, 85*
- Dalmatian dog, 85*
- Darwin, Charles (1809-1882), an English naturalist: his influence on biological thought, 19; his significant work, 34; basic ideas of, proved correct, 35; gives a true explanation of evolution, 79; important elements of his formula, 83; the value of his work, 80; the effects of his work, 86; formula corroborated, 94; and the Lamarckian hypothesis, 28; and congenital causes of change, 81; and natural causation, 83; and artificial selection, 84; and the facts of sexual selection, 86
- Darwin, Erasmus (1731-1802), an English naturalist and physician: and natural evolution, 33; and Lamarck, 34; and evolutionary dynamics, 35; his view of variation, 79
- Darwinism: what it is, 80; and evolution, 19
- Deer, 51*
- Descartes (dä"kärt'), René (1596-1650), a French philosopher, 30
- Development: of organisms, 54; early ideas regarding, 55; as evidence of evolution, 53; of increasing numbers, 55; Wolff's statement of, 55
- Divergent varieties, 40
- Doctrine of Evolution, 34
- Dogs: varieties, 85*; anterior limb of, 49*; relation to other vertebrates, 39*
- Egg: as a minute replica of the complete organism, 55; formation of the, 89, 9*
- Elephant, 51*
- Elodea, 9*
- Embryology: defined, 22; and natural descent, 35; the task of, 53; Greek writings on, 55; its value to evolution, 69; of a frog, 56; mammalian, 60
- Embryonic development: fundamental meaning of, 56; stages in the development of a frog, 57*; a fowl, a rabbit, and a human, 63*
- Empedocles (ëm-pëd'ô-klëz), (ca. 490-430 B.C.), a Greek philosopher: and evolution, 27; his knowledge of fossils, 68
- Environment: and evolution, 79; and heredity, 91
- Evolution: the meaning of, 15; as a science, 18; errors concerning it, 18; history of the concepts of, 25; dynamics of, 24; and embryonic development, 53; applied to the egg, 55; natural processes of, 76; first essential of, 78; indispensable requisite of, 80; modern investigation of its factors, 86; as a real process, 94; and its relation to philosophy, 20; geological, 69; and Aristotle, 20, 29, 78; and Comte de Buffon, 33; Darwin's contribution to, 34; and Darwinism, 19; and religion, 21; and the early Christian Fathers, 30
- Evolutionary dynamics: explained, 76; Darwin's formula of, 35
- Excretion, 7
- Fishes, 40
- Flounder, 65*
- Fossil animals, 66
- Fossil horses, 71*
- Fossil succession, 56
- Fossils: the nature and meaning of, 66; the Greek idea of them, 67; arrayed in their time-order, 72; modern interpretation of, 68; value of, to evolution, 69
- Fowls: varieties of, 87*; embryo, 63*
- French Bulldog, 85*
- Frog: blood corpuscles of, 9*; the embryology of, 56, 57*; relation to other vertebrates, 39
- Functions: of all animals, 7; and common descent of animals, 43
- Galapagos Islands, 23
- Galen (gä'lën), Claudius (130-200?), a Greek physician and medical writer, 31
- Gastrula, 59
- Genesis, 30
- Genetics, 88
- Geographical distribution, 23
- Geological evolution, 69
- Geology, 70

- Germ-plasm, 89
 Gesner (gēs'nēr), Konrad von (1516-1565), a Swiss naturalist, 31
 Greeks: and natural history, 26; their writings on embryology, 55; their ideas of fossils, 67; their concept of variation and heredity, 78
 Grew (grō), Nehemiah (1641-1712), an English botanist, 32
 Greyhound, 85*
 Haller (hāl'ēr), Albrecht von (1708-1777), a Swiss physiologist, 55
 Harvey, William (1578-1657), an English physician: his services to biology, 31; his ideas of development, 55
 Heape, Walter (1855-), an English biologist, 94
 Heraclitus (hēr"à-klí'tūs), (ca. 535-475 B.C.), a Greek physicist, 27
 Heredity: as an established fact, 24; Aristotle's concept of, 28; Darwin's emphasis of, 35; the Greek concept of, 78; researches on, 86; physical basis of, 88; and environment, 91; a universal process of organisms, 77
 Heron, 39*
 Hereditary derivation, 38
 Hippocrates (hī-pōk'rà-tēz), (ca. 460-377 B.C.), a Greek physician, 31
 Hippopotamus, 51*
 History: of the concepts of evolution, 25; of fossil animals, 66
 Homologous limbs, 48
 Hooke, Robert (1635-1703), an English natural philosopher and mathematician, 32
 Horse: limbs of, 49*, 51*
 Human: *see* Man
 Huxley (hüks'li), Thomas Henry (1825-1895), an English biologist, 4
 Hyrax, 51*
 Inheritance: and congenital factors, 83, 93*
 Insects, 42
 Intrinsic nerves, 8
 Invertebrates: phyla of, 42; alimentaria among, 44, 41*
 Japanese Spaniel, 85*
 Jonston, John (1603-1675), an English naturalist, 31
 Katabolism, 12
 Lamarck, Jean Baptiste de (1744-1829), French naturalist: and evolution, 34; and the Lamarckian hypothesis, 28; and evolutionary dynamics, 35; his view of variation, 79; and paleontology, 33
 Lamarckian hypothesis, 28
 Lamprey, 39*
 Law of recapitulation: stated, 56; confidence in, 60
 Leeuwenhock (lā'vën-hōök"), Anton van (1632-1723), a Dutch naturalist, 32
 Life, origin of, 13
 Limbs: of mammals, 48; homologous, 48; analogous, 48, 49*, 51*
 Linnaeus (li-nē'ūs), Carolus (1707-1778), a Swedish botanist and naturalist: and the classification of plants, 32, 37
 Lipoids, 11
 Living matter, 13
 Living objects, 3
 Locomotion, 7
 Lyell, Sir Charles (1797-1875), an English geologist, 69
 Man: brain, 61*; embryo of, 63*; fossil, 73*; limb, 49*; organism, 50; relation to other vertebrates, 39*
 Mammalia: characteristics of, 40; embryology of, 60
 Mammals: the skull of, 48; limbs of, 48, 49*, 51*
 Mathew, Patrick, 81
 Mendel, Gregor (1822-1884), an Austrian botanist, 90
 Mendelian theory, 92
 Mesozoic age, 74
 Metabolism, 11
 Microscope: and the origin of living matter, 13; early makers of, 32
 Middle Ages, 30
 Morphology: defined, 22; complete task of, 44; and natural descent, 35; its value to evolution, 69; and the law of recapitulation, 56; applied to fossils, 66
 Mosaic account of creation, 30
 Motion, 7
 Mutation, 90
 Natural causation, 83
 Natural descent, 35
 Natural history: contributors to, 31; and the Greeks, 26; the modern era of, 32
 Natural selection, 83
 Neanderthal Man, 75
 Nerve cells, 9*
 Notochord, 58
 Nucleus, 8
 Ontogeny (ōn-tōj'ē-nī), 56
 Orders, 40
 Organic evolution: what it is, 17; formulation of its principles, 25
 Organic nature, 43
 Organic systems, 44

- Organisms:** defined, 5; structurally considered, 6; and adaptation, 6; universal processes of, 77; universal feature of, 77; resemblance of, 23; agreement of, 76; their power to develop, 54; and genealogical production, 64
- Organs:** as constituent parts of an organism, 6; and their tissues, 7
- Origin of species:** contribution of embryology to, 53; and adaptation, 77
- Origin of Species:* published in 1859, 35; its presentation of Darwinism, 80
- Overproduction,** 81
- Oxidation,** 12
- Paleontology** (pā"lê-ôn-tōl'ô-jī): defined, 23; department of, organized, 32; as a department of zoology, 66; organization of, 68; and natural descent, 35; in the study of fossils, 66; conclusions from the facts of, 74
- Paleozoic era,** 72
- Palingenetic** (pāl"īn-jê-nēt'ik), 64
- Phillips, John Charles** (1800-1874), an English geologist, 94
- Phylogeny** (fī-lōj'ê-nī), 56
- Phylum** (fī'lūm): defined, 42
- Pig,** 51*
- Pithecanthropus** (pith"ê-kăn-thrō'pūs), 75
- Potato cells,** 9*
- Pre-natal influence,** 94
- Protein,** 10
- Proterozoic** (prōt"ēr-ô-zō'ik) era, 72
- Protoplasm:** what it is, 10; how it comes into existence, 13; in organisms, 5; of a cell, 8; and oxidation, 12; and progressive development of compounds, 14
- Rabbit,** 63*
- Ray, John** (1628-1705), an English naturalist, 37
- Recapitulation:** condensation of embryonic, 64; of a frog, 56; of mammalia, 60; illustrations of, 62
- Relationship:** determined through classification, 42; determined by essential likenesses, 46
- Religion,** 21
- Reproduction,** 7
- Reptiles,** 40
- Respiration,** 7
- Rhinoceros,** 51*
- Robin,** 39*
- Saint Bernard dog,** 85*
- Salmon,** 39*
- Schleiden** (shlī'dēn), Matthias Jakob (1804-1881), a German botanist: and the cell-doctrine, 32; his conception of the cell, 55
- Schwann** (shvān), Theodor (1810-1882), a German physiologist and anatomist: and the cell-doctrine, 32; his conception of the cell, 55
- Science:** defined, 2; problem of, 78
- Sciences,** 25
- Scotch Terrier,** 85*
- Seal,** 49*
- Selection,** artificial, 35, 84; natural, 83
- Sensation,** 7
- Sexual selection:** and Darwin's theory, 35, 86
- Shark,** 39*
- Skulls:** of vertebrates, 48, 47*
- Smith, William** (1769-1839), an English geologist: and geological evolution, 69; and paleontology, 33
- South America,** 23
- Special cases,** 65
- Species,** 40
- Spencer, Herbert** (1820-1903), an English philosopher, 81
- Spontaneous generation,** 13
- Starch,** 11
- Steno** (stā'nō), Nicolaus (1638-1687), a Danish anatomist, 68
- Suarez** (swā'rās), Francisco (1548-1617), a Spanish Jesuit theologian, 30
- Survival of the fittest,** 81
- Swammerdam** (swām'mer-dām), Jan (1637-1680), a Dutch naturalist, 32
- Tadpole,** 58
- Teleology** (tēl"ê-ōl'ô-jī): explained, 20; and Anaxagoras, 29
- Thales** (thā'lēz) (*ca.* 640-*ca.*546 B.C.), a Greek philosopher, astronomer, and geometer, 26
- Tissues:** as a part of an organ, 7; as unitary masses of protoplasm, 55
- Titian** (tīsh'ān) (1477-1576), a Venetian artist, 31
- Trial and error,** 83
- Tschermak** (chēr'māk), Gustav (1836-), an Austrian mineralogist, 90
- Uniformitarianism,** 69
- Variation:** defined, 77; as an established fact, 24; the Greek concept of, 78; Buffon's view of, 79; Lamarck's view of, 79; Erasmus Darwin's view of, 79; as a requisite of evolution, 80
- Varieties,** 38
- Vertebrates:** component classes of, 43; alimentary apparatus, 44; brains of, 46, 39*, 45*, 47*
- Vesalius** (vê-sā'li-ūs), Andreas (1514-1564), a Belgian anatomist, 31
- Vestigial** (vēs'tij'ī-āl) structure: defined, 28; significance of, 48

- Vinci (vĕn'chĕ), Leonardo da (1452-1519), a Florentine artist and scientist, 68
- Vital principle, 4
- Vries, Hugo de (1848-), a Dutch botanist, 90
- Wallace, Alfred Russel (1823-1913), an English naturalist, 81
- Warfare, 82
- Water, 11
- Weismann, August (1834-1914), a German zoologist: identifies chromosomes, 88; experiment of, 92
- Whales: anterior limb of, 49*; vestigial structures of, 50
- Wolff, Kaspar Friedrich (1733-1794), a German anatomist and physiologist, 55
- Wotton, Sir Henry (1568-1639), an English author, 31
- Zoology, defined, 1; department of, organized, 32; and classification of structural qualities, 37; and comparative anatomy, 37; task of, 38
- Zygote (zi'gōt), 89

KEY TO PRONUNCIATION

ā as in dāy	ē as in mēte	ī as in time	ō as in nōt
â " " senâte	ê " " êvent	î " " îdea	ô " " lôrd
ă " " ädd	ĕ " " ĕnd	ï " " ill	
â " " câre	ĕ " " tĕrm	î " " fîrm	û " " ūse
ä " " fâr	ġ = j (gentile)	ō " " ôld	û " " ûnite
à " " lâst	ġ as in get	ô " " ôbey	û " " tûrn

