

UNIVERSAL  
LIBRARY

**OU\_150226**

UNIVERSAL  
LIBRARY



OSMANIA UNIVERSITY LIBRARY

Call No. 532 / B557 Accession No. 999

Author Babant W. H

Title Treatise on Hydromechanics

This book should be returned on or before the date last marked below.



# **HYDROMECHANICS**

**PART I**

## **HYDROSTATICS**

## **A Treatise on Hydromechanics.**

Part I. **HYDROSTATICS.** By W. H. BESANT, Sc.D., F.R.S., and A. S. RAMSEY, M.A., Eighth Edition, Revised and Enlarged. Demy 8vo. 10s. 6d. net.

Part II. **HYDRODYNAMICS.** By A. S. RAMSEY, M.A. 10s. 6d. net.

**School World:** 'The book will rank for many years to come as the standard introductory book on the subject.'

## **A Treatise on Dynamics.**

By W. H. BESANT, Sc.D., F.R.S., and A. S. RAMSEY, M.A., Fellow and Lecturer of Magdalene College, Cambridge. New and Revised Edition. 8vo. 12s. net.

For this edition the text has been revised by Mr A. S. Ramsey, and while the main features of the book have been preserved, there has been some rearrangement, and some additional matter has been introduced, more particularly in the later chapters. A number of examples from recent examination papers have been inserted, so that the book now contains over a thousand examples for solution, besides a large number of examples worked out in the text. The ground covered represents an adequate course in Dynamics for students reading for Part II. Sch. A of the Cambridge Mathematical Tripos.

## **A Text-Book of Geometrical Optics.**

By A. S. RAMSEY, M.A., Fellow and Lecturer of Magdalene College, Cambridge. Demy 8vo. 7s. 6d.

This Book covers Part I. of the Mathematical Tripos.

**Cambridge Review:** 'The style is clear; the diagrams are well drawn; the choice of direction of measurement, which causes the beginner much trouble, is sensibly and lucidly explained; numerous examples from recent University and College examinations have been collected together, and the student who works through it with care ought to have a sound knowledge of the principles of geometrical optics.'

G. BELL AND SONS, LTD.

YORK HOUSE, PORTUGAL STREET, W.C. 2

A TREATISE  
ON  
HYDROMECHANICS

PART I  
HYDROSTATICS

BY

W. H. BESANT, Sc.D., F.R.S.

LATE FELLOW AND LECTURER OF ST JOHN'S COLLEGE, CAMBRIDGE

AND

A. S. RAMSEY, M.A.

PRESIDENT AND LECTURER OF MAGDALENE COLLEGE, CAMBRIDGE

*EIGHTH EDITION*

*Ἄριστον μὲν ὕδωρ*

LONDON  
G. BELL & SONS, LTD.

1919



## PREFACE TO THE SEVENTH EDITION

**T**HIS edition is mainly a reprint of the last, but results involving Elliptic Functions have been reduced to the notation of Weierstrass and the chapter on the Equilibrium of Revolving Liquid has been partly rewritten and contains some notice of recent research. Readers of text-books have too long been allowed to regard Maclaurin's Spheroids and Jacobi's Ellipsoid as a kind of mathematical accident, somewhat resembling examples that are made "to come out"; and though it is impossible to reproduce here the extensive work of Poincaré and others on this subject, we have drawn attention to the fact that these forms of equilibrium are only special cases in sequences of possible forms, and we have given some references that will be useful to those who desire to pursue the subject further.

In some of the other chapters additional references have been given in footnotes in the hope of increasing the utility of the book.

W. H. B.  
A. S. R.

*October, 1911.*

## PREFACE TO THE EIGHTH EDITION

**F**OR this edition Chapter V on The Stability of Equilibrium of Floating Bodies has been partly rewritten. It now contains a new method of treatment of the general problem and an important correction to Leclert's Theorem, for both of which I am indebted to Dr Bromwich. In other respects this edition differs but little from the last.

A. S. R.

*July, 1919.*

# CONTENTS

## HYDROSTATICS

### CHAPTER I

ARTICLES		PAGE
1—14	Definitions. Equality of pressure. Transmission of pressure. Measure of density . . . . .	1
	Examples . . . . .	8

### CHAPTER II

15—20	Conditions of equilibrium . . . . .	10
21—26	Surfaces of equal pressure. ✓ . . . . .	14
27	Heterogeneous liquid . . . . .	20
28—29	Examples . . . . .	21
30—32	Rotating fluid . . . . .	23
	Examples . . . . .	25

### CHAPTER III

33—47	Resultant pressures. Centres of pressure ✓ . . . . .	31
	Examples . . . . .	45

### CHAPTER IV

48—55	The equilibrium of a floating body. ✓ Surface of buoyancy. Positions of equilibrium . . . . .	51
56—64	Surfaces of buoyancy in special cases . . . . .	58
	Examples . . . . .	64

### CHAPTER V

65—73	Stability of equilibrium. Metacentre . . . . .	68
74	Dupin's theorem . . . . .	74
75	Leclert's theorem . . . . .	75
76	Increase in load . . . . .	76
77	Effect of screw on steamer . . . . .	76
78—79	Surface of buoyancy in general . . . . .	77
80	Surface of flotation. Leclert's Theorem . . . . .	78
81	Examples . . . . .	79
82—89	Finite displacements. Cases of constraint . . . . .	82
90—92	Heterogeneous liquids . . . . .	88
93—105	Application of principle of energy . . . . .	90
	Examples . . . . .	101

## CHAPTER VI

ARTICLES		PAGE
106—108	Oscillations of floating bodies . . . . .	109
	Examples . . . . .	113

## CHAPTER VII

109—111	Boyle's Law. Absolute temperature . . . . .	116
112—121	Mixture of gases. Dew. Specific heat . . . . .	119
122—129	The atmosphere. Determination of heights . . . . .	125
	Examples . . . . .	133

## CHAPTER VIII

130—132	Tension of flexible surfaces . . . . .	137
133—137	Lintearia and Elastica . . . . .	139
138—155	Tension and pressure . . . . .	144
	Examples . . . . .	156

## CHAPTER IX

156—159	Rigid or Elastic Lamina . . . . .	160
160—162	The Lintearia . . . . .	163
	Examples . . . . .	165

## CHAPTER X

163—169	Surface Tension. Capillary Curve . . . . .	166
170—171	Parallel Plates. Circular Tube . . . . .	173
172—174	Drops of Liquid . . . . .	177
175	Floating Needle . . . . .	182
176—185	Liquid Films . . . . .	182
	Examples . . . . .	192

## CHAPTER XI

186—193	Relative equilibrium of a mass of rotating liquid. Application to the figure <sup>o</sup> of the Earth . . . . .	198
194—200	Jacobi's theorem . . . . .	206
201	Elliptic cylinder . . . . .	212
202	Poincaré's theorem . . . . .	212
203	Other equilibrium forms . . . . .	213
	Examples . . . . .	217

MISCELLANEOUS EXAMPLES . . . . .	220
----------------------------------	-----

# HYDROSTATICS

## CHAPTER I

1. WE learn from common experience that such substances as air and water are characterised by the ease with which portions of their mass can be removed, and by their extreme divisibility. These properties are illustrated by various common facts; if, for instance, we consider the ease with which fluids can be made to permeate each other, the extreme tenuity to which one fluid can be reduced by mixture with a large portion of another fluid, the rarefaction of air which can be effected by means of an air-pump, and other facts of a similar kind, it is clear that, practically, the divisibility of fluid is unlimited: we find, moreover, that in separating portions of fluids from each other, the resistance offered to the division is very slight, and in general almost inappreciable. By a generalization from such observations, the conception naturally arises of a substance possessing in the highest degree these properties, which exist, in a greater or less degree, in every fluid with which we are acquainted, and hence we are led to the following

### **Definition of a Perfect Fluid.**

2. *A perfect fluid is an aggregation of particles which yield at once to the slightest effort made to separate them from each other.*

If then an indefinitely thin plane be made to divide such a fluid in any direction, no resistance will be offered to the division, and the pressure exerted by the fluid on the plane will be entirely normal to it; that is, a perfect fluid is assumed to have no 'viscosity,' no property of the nature of friction.

The following fundamental property of a fluid is therefore obtained from the above definition.

*The pressure of a perfect fluid is always normal to any surface with which it is in contact.*

As a matter of fact, all fluids do more or less offer a resistance to separation or division, but, just as the idea of a rigid body is obtained from the observation of bodies in nature which only change form slightly on the application of great force, so is the idea of a perfect fluid obtained from our experiences of substances which

possess the characteristics of extremely easy separability and apparently unlimited divisibility.

The following definition will include fluids of all degrees of viscosity.

*A fluid is an aggregation of particles which yield to the slightest effort made to separate them from each other, if it be continued long enough.*

Hence it follows that, in a viscous fluid at rest, there can be no tangential action, or shearing stress, and therefore, as in the case of a perfect fluid,

*The pressure of a fluid at rest is always normal to any surface with which it is in contact.*

Thus all propositions in Hydrostatics are true for all fluids whatever be the viscosity.

In Hydrodynamics it will be found that the equations of motion are considerably modified by taking account of the viscosity of a fluid.

**3.** Fluids are divided into Liquids and Gases; the former, such as water and mercury, are not sensibly compressible except under very great pressures; the latter are easily compressible, and expand freely if permitted to do so.

Hence the former are sometimes called inelastic, and the latter elastic fluids.

**4.** Fluids are acted upon by the force of gravity in the same way as solids; with regard to liquids this is obvious; and that air has weight can be shewn directly by weighing a closed vessel, exhausted as far as possible: moreover, the phenomena of the tides shew that fluids are subject to the attractive forces of the sun and moon as well as of the earth, and it is assumed, from these and other similar facts, that fluids of all kinds are subject to the law of gravitation, that is, that they attract, and are attracted by, all other portions of matter, in accordance with that law.

#### **Measure of the Pressure of Fluids.**

**5.** Consider a mass of fluid at rest under the action of any forces, and let  $A$  be the area of a plane surface exposed to the action of the fluid, that is, in contact with it, and  $P$  the force which is required to counterbalance the action of the fluid upon  $A$ . If the action of the fluid upon  $A$  be uniform, then  $\frac{P}{A}$  is the pressure

on each unit of the area  $A$ . If the pressure be not uniform, it must be considered as varying continuously from point to point of the area  $A$ , and if  $\varpi$  be the force on a small portion  $\alpha$  of the area about a given point, then  $\frac{\varpi}{\alpha}$  will approximately express the rate of pressure over  $\alpha$ . When  $\alpha$  is indefinitely diminished let  $\frac{\varpi}{\alpha}$  ultimately =  $p$ , then  $p$  is defined to be the measure of the pressure at the point considered,  $p$  being the force which would be exerted on an unit of area, if the rate of pressure over the unit were uniform and the same as at the point considered.

The force upon any small area  $\alpha$  about a point, the pressure at which is  $p$ , is therefore  $p\alpha + \gamma$ , where  $\gamma$  vanishes ultimately in comparison with  $p\alpha$  when  $\alpha$  (and consequently  $p\alpha$ ) vanishes.

6. *The pressure at any point of a fluid at rest is the same in every direction.*

This is the most important of the characteristic properties of a fluid; it can be deduced from the fundamental property of a fluid in the following manner:

If we consider the equilibrium of a small tetrahedron of fluid, we observe that the pressures on its faces, and the impressed force on its mass, form a system of equilibrating forces.

The former forces depending on the areas of the faces vary as the square, and the latter depending on the volume and density varies as the cube of one of the edges of the solid, which is considered to be homogeneous, and therefore supposing the solid indefinitely diminished, while it retains always a similar form, the latter force vanishes in comparison with the pressures on the faces; and these pressures consequently form of themselves a system of forces in equilibrium.

Let  $p, p'$  be the rates of the pressure on the faces  $\underline{ABC}, \underline{BCD}$ , and resolve the forces parallel to the edge  $AD$ ; then, since the projections of the areas  $ABC, BCD$  on a plane perpendicular to  $AD$  are the same (each equal to  $\alpha$  suppose) we have ultimately,

$$p\alpha = p'\alpha,$$

or

$$p = p'$$

And similarly it may be shewn that the pressures on the other two faces are each equal to  $p$  or  $p'$ .

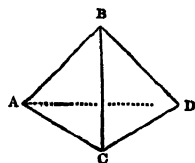

As the tetrahedron may be taken with its faces in any direction, it follows that the pressure at a point is the same in every direction.

This proposition is also true if the fluid be in motion, for by D'Alembert's Principle the reversed effective forces and the impressed forces which act upon the mass of fluid must balance the pressures on its faces, and the effective forces are of the same order of small quantities as the impressed forces and vanish in comparison with the pressures.

7. The following proof of the foregoing proposition is taken from Cauchy's *Exercices*\*.

Let  $P$  and  $Q$  be two points in a fluid at a finite distance from each other; about  $PQ$  as axis describe a cylinder of very small radius, draw a plane through  $Q$  perpendicular to  $QP$ , draw any plane through  $P$ , and consider the equilibrium of the mass  $PQ$ .

The pressures on its ends and on its curved surface, and the impressed forces which act upon it, form a system of balancing forces.

Let  $p, p'$  be the pressures at  $Q$  and  $P$ ,  $\alpha$  the area of the section  $Q$  of the cylinder, and  $\alpha'$  of the section  $P$ ; then the pressure  $p'\alpha'$  on the end  $P$ , resolved parallel to the axis of the cylinder, is equal to  $p'\alpha$ , and therefore

$$p'\alpha - p\alpha = \text{the impressed force, resolved parallel to } QP.$$

Now whatever be the direction of the plane through  $P$ , this impressed force, when the radius of the cylinder is indefinitely diminished, is ultimately equal to the impressed force on the portion  $QP$  of the cylinder cut off by a plane through  $P$  perpendicular to the axis†, that is, to

$$\int_0^{PQ} f \rho \alpha dx,$$

\* *Seconde Année*, 1827, p. 23.

† The following considerations may complete this part of the proof: .

Let  $AB, A'B'$  be the two planes through  $P$ ;  $\rho, \rho'$  the mean densities of  $APA', BPB'$ ; and  $f, f'$  the accelerations of the forces which are acting on these portions of fluid.

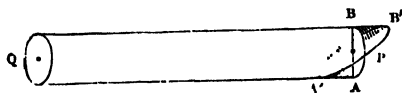

Then the difference of the forces on  $QAB$  and  $QA'B'$  (the volumes of which are equal)

$$\begin{aligned} &= \text{the difference of the forces on } APA' \text{ and } BPB' \\ &= (\rho'f' - \rho f) \cdot \text{vol. } APA' \\ &= \delta(\rho f) \cdot \frac{2}{3\pi} \alpha \alpha', \end{aligned}$$

where  $mf$  is the force on a particle  $m$  of the fluid at a distance  $x$  from  $Q$ . Hence

$$p' = p + \int_0^{PQ} \rho f dx,$$

or  $p'$  is constant for all positions of the plane through  $P$ .

### Transmission of Fluid Pressure.

8. *Any pressure, or additional pressure, applied to the surface or to any other part of a liquid at rest, is transmitted equally to all parts of the liquid.*

This property of liquids is a direct result of experiment, and, as such, is sometimes assumed. It is however deducible from the definition of a fluid.

Let  $P$  be a point in the surface of a liquid at rest, and  $Q$  any other point in the liquid; about the straight line  $PQ$  describe a cylinder, of very small radius, bounded by the surface at  $P$  and by a plane through  $Q$ , perpendicular to  $QP$ .

If the pressure at  $P$  be increased by  $p$ , the additional force on the cylinder, resolved in the direction of its axis, is  $p\alpha$ ,  $\alpha$  being the area of the section of the cylinder perpendicular to its axis, and this must be counteracted by an equal force  $p\alpha$  at  $Q$  in the direction  $QP$ , since the pressure of the liquid on the curved surface is perpendicular to the axis. The pressure at  $Q$  is therefore increased by  $p$ .

If the straight line  $PQ$  do not lie entirely in the liquid,  $P$  and  $Q$  can be connected by a number of straight lines, all lying in the liquid, and a repetition of the above reasoning will shew that the pressure  $p$  is transmitted, unchanged, to the point  $Q$ .

9. In consequence of this property, a mass of liquid can be used as a 'machine' for the purpose of multiplying power.

Thus, if in a closed vessel full of water two apertures be made and pistons  $A, A'$  fitted in them, any force  $P$  applied to one piston must be counteracted by a force  $P'$  on the other piston, such that  $P' : P$  in the ratio of the area  $A' : A$ , for the increased rate of pressure at every point of  $A$  is transmitted to every point of  $A'$ , and the force upon  $A'$  depends therefore upon its area\*.

and therefore 
$$p' = p + \int_0^{QP} \rho f dx + \frac{2}{3\pi} AA' \cdot \delta(\rho f).$$

The forces being continuous, the last term is obviously evanescent compared with the other quantities in the equation, and  $p'$  is therefore constant.

\* Bramah's Press is an instance of the practical use of this property of liquids.

The action between the two is analogous to the action of a lever, and it is clear that by increasing  $A'$  and diminishing  $A$ , we can make the ratio  $P' : P$  as large as we please.

10. The pressure of a gaseous fluid is found to depend upon its density and temperature, as well as upon the nature of the fluid itself.

When the temperature is constant, experiment shews that the pressure varies inversely as the space occupied by the fluid, that is, directly as its density.

This law was first stated by Boyle, but it is a consequence of the more general law that the pressure of a mixture of gases that do not act chemically on each other is the sum of the pressures the gases would exert if they filled the containing vessel separately. For doubling the quantity of gas in the vessel would double the pressure, and a similar proportionate change of pressure would take place for any other change of quantity.

Hence if  $\rho$  be the density of a certain quantity of a gaseous fluid, and  $p$  its pressure, then, as long as the temperature remains the same,

$$p = k\rho,$$

where  $k$  is a constant, to be determined experimentally for the fluid at a given temperature.

If  $v$  be the volume of the gas at the pressure  $p$ , and  $v'$  the volume at the pressure  $p'$ ,

$$pv = p'v',$$

or  $pv$  is constant for a given temperature.

11. The **Elasticity** of a fluid is measured by the ratio of a small increase of pressure to the cubical compression produced by it.

If  $v$  be the volume, the small cubical compression is  $-\frac{dv}{v}$ , and the measure of the elasticity is

$$-v \frac{dp}{dv}.$$

In the case of a gas at constant temperature  $pv$  is constant,

and  $\therefore p + v \frac{dp}{dv} = 0,$

so that the measure of the elasticity is equal to that of the pressure.

If the relation between the elasticity and the pressure is given, we can deduce the relation between the pressure and the volume.

For instance, if we can imagine the existence of a fluid in which the elasticity is double the pressure, we have

$$-v \frac{dp}{dv} = 2p,$$

from which it follows that  $pv^2$  is constant.

### Measures of Weight, Mass, and Density.

12. The weight, mass, and density of a fluid are measured in the same way as for solid bodies.

If  $W$  be the weight of a mass  $M$  of fluid, then, in accordance with the usual conventions which define the units of mass and force,

$$W = Mg.$$

If  $V$  be the volume of the mass  $M$  of fluid of density  $\rho$ , then

$$M = \rho V,$$

and

$$\therefore W = g\rho V.$$

For the standard substance,  $\rho = 1$ , and therefore the unit of mass is the mass of the unit of volume of the standard substance.

If the unit of mass is a pound, the equation,  $W = Mg$ , shews that the action of gravity on a pound is equivalent to  $g$  units of force. The unit of force is therefore, roughly, equal to the weight of half an ounce, and it is called the Poundal.

13. In the previous articles no account has been taken of fluids in which the density is variable; but it is easy to conceive the density of a mass of liquid varying continuously from point to point, and it will be hereafter found that a mass of elastic fluid, at rest under the action of gravity, and having a constant temperature throughout, is necessarily heterogeneous: the density at a point of a fluid must therefore be measured in the same way as the pressure at a point, or any other continuously varying quantity.

#### *Measure of the density at any point of a heterogeneous fluid.*

Let  $m$  be the mass of a volume  $v$  of fluid enclosing a given point, and suppose  $\rho$  the density of a homogeneous fluid such that the mass of a volume  $v$  is equal to  $m$ , or such that

$$m = \rho v;$$

then  $\rho$  may be defined as the mean density of the portion  $v$  of the heterogeneous fluid, and the ultimate value of  $\rho$  when  $v$  is indefinitely diminished, supposing it always to enclose the point, is the density of the fluid at that point.

14. To find the work done in compressing a gas.

Let  $v$  be the volume of a gas at the pressure  $p$ ,  $dS$  an element of the surface of the vessel containing it, and  $dn$  an element of the normal to  $dS$  drawn inwards.

Then the work done in a small compression

$$= p \Sigma dS dn = -p dv,$$

and the work done in compressing from volume  $V$  to  $V'$

$$\begin{aligned} &= - \int p dv = - \int \frac{C dv}{v}, \text{ if } pv = C, \\ &= C \log \frac{V}{V'} = pv \log \frac{V}{V'}. \end{aligned}$$

If the compression takes place in a vessel surrounded by the atmosphere, as for example if the gas is confined in a cylinder by a piston, the pressure of the atmosphere assists in the work of compression. Thus if the initial volume is  $V$  at atmospheric pressure  $\Pi$ , the external work done in compressing it to volume  $V'$

$$\begin{aligned} &= - \int_V^{V'} (p - \Pi) dv, \text{ where } pv = \Pi V \\ &= \Pi V \log \frac{V}{V'} - \Pi (V - V'). \end{aligned}$$

### EXAMPLES

(In these Examples  $g$  is taken to be 32, when a foot and a second are units.)

1.  $ABCD$  is a rectangular area subject to fluid pressure;  $AB$  is a fixed line, and the pressure on the area is a given function ( $P$ ) of the length  $BC$  ( $x$ ); prove that the pressure at any point of  $CD$  is  $\frac{dP}{a dx}$ , where  $a = AB$ .

If  $A$  be a fixed point, and  $AB, AD$  fixed in direction, and if  $AB = x$  and  $AD = y$ , the pressure at  $C = \frac{d^2 P}{dx dy}$ .

2. In the equation  $W = g\rho V$ , if the unit of force be 100 lb. weight, the unit of length 2 feet, and the unit of time  $\frac{1}{4}$ th of a second, find the density of water.

3. If a minute be the unit of time, and a yard the unit of space, and if 15 cubic inches of the standard substance contain 25 oz., determine the unit of force.

4. In the equation,  $W = g\rho V$ , the number of seconds in the unit of time is equal to the number of feet in the unit of length, the unit of force is 750 lb. weight, and a cubic foot of the standard substance contains 13500 ounces; find the unit of time.

5. A velocity of 4 feet per second is the unit of velocity; water is the standard substance and the unit of force is 125 lb. weight; find the units of time and length.

6. The number expressing the weight of a cubic foot of water is  $\frac{1}{10}$ th of that expressing its volume,  $\frac{1}{8}$ th of that expressing its mass, and  $\frac{1}{100}$ th of the number expressing the work done in lifting it 1 foot. Find the units of length, mass, and time.

7. If the pressure of the atmosphere be the unit of pressure, the velocity of sound the unit of velocity, and the acceleration due to gravity the unit of acceleration, find roughly the unit of force.

8. If  $a$  feet and  $b$  seconds be the units of space and time, and the density of water the standard density, find the relation between  $a$  and  $b$  in order that the equation,  $W = g\rho V$ , may give the weight of a substance in pounds.

9. A velocity of 8 feet per second is the unit of velocity, the unit of acceleration is that of a falling body, and the unit of mass is a ton; find the density of water.

10. The density at any point of a liquid, contained in a cone having its axis vertical and vertex downwards, is greater than the density at the surface by a quantity varying as the depth of the point. Shew that the density of the liquid when mixed up so as to be uniform will be that of the liquid originally at the depth of one-fourth of the axis of the cone.

11. From a vessel full of liquid of density  $\rho$  is removed  $\frac{1}{n}$ th of the contents, and it is filled up with liquid of density  $\sigma$ . If this operation be repeated  $m$  times, find the resulting density in the vessel.

Deduce the density in a vessel of volume  $V$ , originally filled with liquid of density  $\rho$ , after a volume  $U$  of liquid of density  $\sigma$  has dripped into it by infinitesimal drops.

12. The density of a fluid varies from point to point; considering directions proceeding from a given point, prove that the density varies most rapidly along the normal to the surface of equal density containing the point; and of directions in the tangent plane to this surface, the tangents to its principal sections are those in which the rate of variation of density is greatest and least.

## CHAPTER II

### THE CONDITIONS OF THE EQUILIBRIUM OF FLUIDS

✓ 15. TAKING the most general case, suppose a mass of fluid, elastic or non-elastic, homogeneous or heterogeneous, to be at rest under the action of given forces, and let it be required to determine the conditions of equilibrium, and the pressure at any point.

Let  $x, y, z$  be the co-ordinates referred to rectangular axes, of any point  $P$  in the fluid, and let  $Q$  be a point near it, so taken that  $PQ$  is parallel to the axis of  $x$ .

Take  $x + \delta x, y, z$  as the co-ordinates of  $Q$ ; about  $PQ$  describe a small prism or cylinder bounded by planes perpendicular to  $PQ$ .

Let  $\alpha$  be the area of the section of the cylinder perpendicular to its axis,  $p$  the pressure at  $P$ , and  $p + \delta p$  the pressure at  $Q$ .

Then,  $\alpha$  being very small, the pressure at any point of the plane  $P$  will be very nearly equal to  $p$ , and the pressure upon it will therefore be

$$(p + \gamma) \alpha,$$

where  $\gamma$  vanishes in comparison with  $p$  when  $\alpha$  is indefinitely diminished.

We can therefore consider  $\alpha$  so small that  $\gamma$  may be neglected in comparison with  $p$ , and the pressure on the end  $P$  of the cylinder may be taken equal to  $p\alpha$ , and similarly the pressure on the end  $Q$  equal to

$$(p + \delta p) \alpha.$$

If  $\rho$  be the mean density of the cylinder  $PQ$ , its mass =  $\rho\alpha\delta x$ , and  $X\rho\alpha\delta x$  will represent the force on  $PQ$  parallel to its axis, if  $X\delta m, Y\delta m, Z\delta m$  be the components of the forces acting on a particle  $\delta m$  of fluid at the point,  $(x, y, z)$ .

Hence, for the equilibrium of  $PQ$ ,

$$(p + \delta p) \alpha - p\alpha = X\rho\alpha\delta x,$$

or

$$\delta p = \rho X \delta x.$$

Proceeding to the limit when  $\delta x$ , and therefore  $\delta p$ , is indefinitely diminished,  $\rho$  will be the density at  $P$ , and we obtain

$$\frac{\partial p}{\partial x} = \rho X *.$$

\* In the above proof,  $\alpha$  is taken so small that its linear dimensions may be neglected in comparison with  $\delta x$ ; that is, the change in  $p$ , corresponding to a change  $\delta x$  in  $x$ , is considered undisturbed by any alterations in  $y$  and  $z$ .

By a similar process,

$$\frac{\partial p}{\partial y} = \rho Y,$$

$$\frac{\partial p}{\partial z} = \rho Z.$$

But 
$$dp = \frac{\partial p}{\partial x} dx + \frac{\partial p}{\partial y} dy + \frac{\partial p}{\partial z} dz;$$

$$\therefore dp = \rho (X dx + Y dy + Z dz) \dots\dots\dots(\alpha),$$

the equation which determines the pressure.

16. The pressure is clearly a function of the independent variables  $x$ ,  $y$ , and  $z$ , and we know that

$$\frac{\partial^2 p}{\partial y \partial z} = \frac{\partial^2 p}{\partial z \partial y}, \quad \frac{\partial^2 p}{\partial z \partial x} = \frac{\partial^2 p}{\partial x \partial z}, \quad \frac{\partial^2 p}{\partial x \partial y} = \frac{\partial^2 p}{\partial y \partial x}.$$

Hence we obtain from the preceding equations,

$$\left. \begin{aligned} \frac{\partial}{\partial y} (\rho Z) &= \frac{\partial}{\partial z} (\rho Y) \\ \frac{\partial}{\partial z} (\rho X) &= \frac{\partial}{\partial x} (\rho Z) \\ \frac{\partial}{\partial x} (\rho Y) &= \frac{\partial}{\partial y} (\rho X) \end{aligned} \right\} \dots\dots\dots(\beta).$$

Performing the operations indicated we have

$$Z \frac{\partial \rho}{\partial y} - Y \frac{\partial \rho}{\partial z} = \rho \left( \frac{\partial Y}{\partial z} - \frac{\partial Z}{\partial y} \right),$$

$$X \frac{\partial \rho}{\partial z} - Z \frac{\partial \rho}{\partial x} = \rho \left( \frac{\partial Z}{\partial x} - \frac{\partial X}{\partial z} \right),$$

$$Y \frac{\partial \rho}{\partial x} - X \frac{\partial \rho}{\partial y} = \rho \left( \frac{\partial X}{\partial y} - \frac{\partial Y}{\partial x} \right).$$

Multiplying by  $X$ ,  $Y$ ,  $Z$ , and adding, we obtain

$$X \left( \frac{\partial Y}{\partial z} - \frac{\partial Z}{\partial y} \right) + Y \left( \frac{\partial Z}{\partial x} - \frac{\partial X}{\partial z} \right) + Z \left( \frac{\partial X}{\partial y} - \frac{\partial Y}{\partial x} \right) = 0 \dots\dots(\gamma)$$

as a necessary condition of equilibrium.

The geometrical interpretation of this equation is that the lines of force,

$$\frac{dx}{X} = \frac{dy}{Y} = \frac{dz}{Z},$$

can be intersected orthogonally by a system of surfaces.

**17. Homogeneous Liquids.** If the fluid be homogeneous and incompressible,  $Xdx + Ydy + Zdz$  must be a perfect differential in order that equilibrium may be possible.

In other words, the system of forces must be a conservative system, and the forces can be represented by the space-variations of a potential function.

We then have, if  $V$  be the potential function,

$$dp = -\rho dV,$$

and 
$$\therefore \frac{p}{\rho} + V = C.$$

If, for instance, the forces tend to or from fixed centres and are functions of the distances from those centres, we have

$$X = \Sigma \left\{ \phi(r) \frac{x-a}{r} \right\}, \quad Y = \Sigma \left\{ \phi(r) \frac{y-b}{r} \right\}, \quad Z = \Sigma \left\{ \phi(r) \frac{z-c}{r} \right\},$$

where  $(a, b, c)$  are co-ordinates of the centre to which the force  $\phi(r)$  tends.

Now 
$$r^2 = (x-a)^2 + (y-b)^2 + (z-c)^2,$$

$$\therefore Xdx + Ydy + Zdz = \Sigma \phi(r) dr,$$

and 
$$dp = \rho \Sigma \phi(r) dr.$$

In this case, since

$$\frac{\partial X}{\partial y} = \Sigma \left\{ \phi'(r) \frac{x-a}{r} \frac{y-b}{r} - \phi(r) \frac{x-a}{r^2} \frac{y-b}{r} \right\},$$

and 
$$\frac{\partial Y}{\partial x} = \Sigma \left\{ \phi'(r) \frac{y-b}{r} \frac{x-a}{r} - \phi(r) \frac{y-b}{r^2} \frac{x-a}{r} \right\},$$

it is obvious that the equation ( $\gamma$ ) is always satisfied, but it is not to be inferred that the equilibrium of a heterogeneous fluid is always possible with such a system of forces.

When the density is constant, the equations ( $\beta$ ) become

$$\frac{\partial Z}{\partial y} = \frac{\partial Y}{\partial z}, \quad \frac{\partial X}{\partial z} = \frac{\partial Z}{\partial x}, \quad \frac{\partial X}{\partial y} = \frac{\partial Y}{\partial x},$$

which are in this case always satisfied, and therefore the equilibrium of a homogeneous fluid under the action of such forces is always possible.

**18. Heterogeneous Fluids.** If the law of density be prescribed, that is, if  $\rho$  be a given function of  $x, y, z$ , the conditions to be satisfied in order that a given distribution of force, represented by  $X, Y, Z$ , may maintain the fluid in equilibrium are the equations ( $\beta$ ).

**(19) Elastic Fluids.** When the fluid is elastic, an additional condition is introduced, for, if the temperature be constant,

$$p = k\rho;$$

$$\therefore \frac{dp}{p} = \frac{1}{k} (Xdx + Ydy + Zdz) \dots \dots \dots (\delta).$$

If the forces are derivable from a potential  $V$ , i.e. if

$$Xdx + Ydy + Zdz$$

is a perfect differential  $-dV$ ,

$$k \frac{dp}{p} = -dV,$$

$$\therefore k \log \frac{p}{C} = -V,$$

$$\text{or } p = Ce^{-\frac{V}{k}}, \text{ and } \rho = \frac{C'}{k} e^{-\frac{V}{k}}.$$

When the forces tend to fixed centres and are functions of the distances, Art. (17), this equation takes the form

$$k \frac{dp}{p} = \Sigma \phi(r) dr,$$

and  $p$  can be determined.

If the temperature be variable, the relation between the pressure, density, and temperature is found to be

$$p = k\rho(1 + \alpha t),$$

where  $t$  is the temperature, measured by a Centigrade Thermometer, and  $\alpha = .003665$ .

From this we obtain

$$p = k\rho\alpha \left\{ \frac{1}{\alpha} + t \right\} = K\rho T,$$

where  $K = k\alpha$ , and  $T = \frac{1}{\alpha} + t$ .

$T$  is called the absolute temperature, the zero of which is  $-273^\circ \text{C}$ .

$$\text{In this case } \frac{dp}{p} = \frac{Xdx + Ydy + Zdz}{KT},$$

and therefore  $T$  must be a function of  $x, y, z$ .

In any of these cases, if the pressure at any particular point be given, the constant can be determined.

In the case of elastic fluids, if the mass of fluid and the space within which it is contained be given, the constant is determined.

20. The equation for determining  $p$  may also be obtained in the following manner.

Let  $PQ$  be the axis of a very small cylinder bounded by planes perpendicular to  $PQ$ .

Let  $p$  and  $p + \delta p$  be the pressures at  $P$  and  $Q$ ,  $a$  the areal section, and  $\delta s$  the length of  $PQ$ . Then, if  $S\delta m$  be the component, in the direction  $PQ$ , of the forces acting on an element  $\delta m$ ,

$$(p + \delta p) a - pa = \rho a S \delta s,$$

and therefore, proceeding to the limit,

$$dp = \rho S ds.$$

That is, the rate of increase of the pressure in any direction is equal to the product of the density and the resolved part of the force in that direction.

If  $x, y, z$  be the co-ordinates of  $P$ , and  $X, Y, Z$  the components of  $S$  parallel to the axes,

$$S = X \frac{dx}{ds} + Y \frac{dy}{ds} + Z \frac{dz}{ds},$$

and

$$\therefore dp = \rho (X dx + Y dy + Z dz) \text{ as in Art. (15).}$$

If the position of  $P$  be given by the cylindrical co-ordinates  $r, \theta$ , and  $z$ , and if  $P, T, Z$  be the components of  $S$  in the directions of  $r, \theta, z$ ,

$$S = P \frac{dr}{ds} + T \frac{rd\theta}{ds} + Z \frac{dz}{ds},$$

and the equation for  $p$  becomes

$$dp = \rho \{P dr + T r d\theta + Z dz\}.$$

Again, if the position of  $P$  be given by the ordinary polar co-ordinates  $r, \theta, \phi$ , and if the components of the force be  $R, N$ , and  $T$ , in the directions of  $r$ , of the perpendicular to the plane of the angle  $\theta$ , and of the line perpendicular to  $r$  in that plane, it will be found that

$$\frac{dp}{\rho} = R dr + N r \sin \theta d\phi + T r d\theta.$$

In a similar manner the expression for  $dp$  may be obtained for any other system of co-ordinates.

**21. Surfaces of equal pressure.** In all cases, in which the equilibrium of the fluid is possible, we obtain by integration

$$p = \phi(x, y, z).$$

$$\text{If } p \text{ be constant, } \phi(x, y, z) = p \dots \dots \dots (A)$$

is the equation to a surface at all points of which the pressure is constant, and by giving different values to  $p$  we obtain a series of surfaces of equal pressure, and the external surface, or free surface, is obtained by making  $p$  equal to the pressure external to the fluid.

If the external pressure be zero, the free surface is therefore

$$\phi(x, y, z) = 0.$$

The quantities

$$\frac{\partial \phi}{\partial x}, \quad \frac{\partial \phi}{\partial y}, \quad \frac{\partial \phi}{\partial z},$$

which are proportional to the direction-cosines of the normal at the point  $(x, y, z)$  of the surface (A), are equal to

$$\frac{\partial p}{\partial x}, \quad \frac{\partial p}{\partial y}, \quad \frac{\partial p}{\partial z},$$

respectively, i.e. to  $\rho X, \rho Y, \rho Z$ , and are therefore proportional to  $X, Y, Z$ .

Hence the resultant force at any point is in direction of the normal to the surface of equal pressure passing through the point.

\* *The surfaces of equal pressure are therefore the surfaces intersecting orthogonally the lines of force.*

It follows from this result that a necessary condition of equilibrium is the existence of a system of surfaces orthogonal to the lines of force, a conclusion derivable also from the equation ( $\gamma$ ) of Art. (16), for that equation is the known analytical condition requisite for the existence of such a system.

22. If the fluid be a homogeneous liquid, that is, if  $\rho$  is constant,  $Xdx + Ydy + Zdz$  must be a perfect differential, or in other words, the system of forces must be a conservative system.

In general, when the force-system is conservative,  $\rho$  must be a function of the potential  $V$ .

For  $dp = -\rho dV$ , and,  $dp$  being a perfect differential,  $\rho$  must be a function of  $V$ ; hence  $V$ , and therefore  $\rho$ , is a function of  $p$ , and surfaces of equal pressure are equipotential surfaces, and are also surfaces of equal density\*.

If the fluid be elastic and the temperature variable

$$\frac{dp}{p} = -\frac{dV}{KT}.$$

Hence by a similar process of reasoning  $T$  is a function of  $p$ , and surfaces of equal pressure are also surfaces of equal temperature.

If however  $Xdx + Ydy + Zdz$  be not a perfect differential, these surfaces will not in general coincide.

\* These results may also be obtained in the following manner:

Consider two consecutive surfaces of equal pressure, containing between them a stratum of fluid, and let a small circle be described about a point  $P$  in one surface, and a portion of the fluid cut out by normals through the circumference. The portion of fluid is kept at rest by the impressed force, and by the pressures on its ends and on its circumference. Being very nearly a small cylinder, and the pressures at all points of its circumference being equal, the difference of the pressures on its two faces must be due to the force, which must therefore act in the same direction as these pressures, i.e. in direction of the normal at  $P$ .

If the forces are derivable from a potential, the resulting force is perpendicular to the equipotential surfaces, and the surfaces of equal pressure are therefore identical with the equipotential surfaces.

Again, considering the equilibrium of the elemental cylinder, the force acting upon it, per unit of mass, is equal to the difference of potentials divided by the distance between the surfaces of equal pressure, and as the mass of the element is directly proportional to this distance, it follows that the density must be constant, that is, the surfaces of equal pressure are also surfaces of equal density.

## SURFACES OF EQUAL PRESSURE

Let the fluid be heterogeneous and incompressible; then the surfaces of equal pressure and of equal density are given respectively by the equations

$$\text{or } \left\{ \begin{array}{l} dp = 0, \quad d\rho = 0, \\ Xdx + Ydy + Zdz = 0 \\ \frac{\partial \rho}{\partial x} dx + \frac{\partial \rho}{\partial y} dy + \frac{\partial \rho}{\partial z} dz = 0 \end{array} \right\} \dots\dots\dots(B).$$

These then are the differential equations of surfaces which by their intersections determine curves of equal pressure and density.

From (B) we obtain

$$\frac{dx}{Z \frac{\partial \rho}{\partial y} - Y \frac{\partial \rho}{\partial z}} = \frac{dy}{X \frac{\partial \rho}{\partial z} - Z \frac{\partial \rho}{\partial x}} = \frac{dz}{Y \frac{\partial \rho}{\partial x} - X \frac{\partial \rho}{\partial y}} \dots\dots\dots(C).$$

But from the conditions of equilibrium we have

$$\begin{aligned} \rho \frac{\partial X}{\partial y} + X \frac{\partial \rho}{\partial y} &= \rho \frac{\partial Y}{\partial x} + Y \frac{\partial \rho}{\partial x}, \\ \rho \frac{\partial Y}{\partial z} + Y \frac{\partial \rho}{\partial z} &= \rho \frac{\partial Z}{\partial y} + Z \frac{\partial \rho}{\partial y}, \\ \rho \frac{\partial Z}{\partial x} + Z \frac{\partial \rho}{\partial x} &= \rho \frac{\partial X}{\partial z} + X \frac{\partial \rho}{\partial z}, \end{aligned}$$

and therefore the equations (C) become

$$\frac{dx}{\frac{\partial Z}{\partial y} - \frac{\partial Y}{\partial z}} = \frac{dy}{\frac{\partial X}{\partial z} - \frac{\partial Z}{\partial x}} = \frac{dz}{\frac{\partial Y}{\partial x} - \frac{\partial X}{\partial y}} \dots\dots\dots(D),$$

the differential equations of the curves of equal pressure and density.

**23.** We shall now shew how to obtain the fundamental pressure equation by considering the equilibrium of a finite mass of fluid.

Let  $S$  be any closed surface drawn in the fluid, and  $l, m, n$  the direction-cosines of the normal at any point drawn outwards. The conditions of equilibrium of the mass of fluid within the surface  $S$  are summarised in the statement that the normal pressures on the boundary must counterbalance the effect of the given forces acting throughout the mass. Thus by resolving parallel to the axes we get three equations of the type

$$\iiint l p dS = \iiint \rho X dx dy dz \dots\dots\dots(1);$$

and by taking moments about the axes we get three other equations of the type

$$\iint p (ny - mz) dS = \iiint \rho (yZ - zY) dx dy dz \dots\dots\dots(2),$$

where the double integrations extend to the whole surface  $S$  and the triple integrations are throughout the space enclosed.

Now consider the integral  $\iiint \frac{\partial p}{\partial x} dx dy dz$  with the same range of integration. Taking a thin prism parallel to  $x$  which necessarily crosses the surface an even number of times, and cuts out elements  $dS_1, dS_2, dS_3, \dots$  at the points  $P_1, P_2, P_3, \dots$ , and integrating along this prism, we get

$$\iiint \frac{\partial p}{\partial x} dx dy dz = \iint p dy dz \dots\dots\dots(3)$$

taken between the limits  $P_1$  to  $P_2, P_3$  to  $P_4, \&c.$

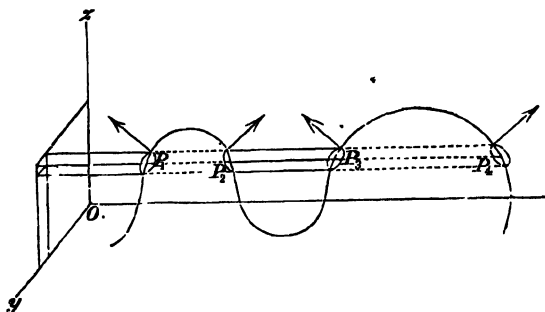

But if  $\theta_1, \theta_2, \theta_3, \dots$  are the inclinations to the axis of  $x$  of the outward-drawn normals at  $P_1, P_2, P_3, \dots$ , we have

$$dy dz = -dS_1 \cos \theta_1 = dS_2 \cos \theta_2 = -dS_3 \cos \theta_3 = \dots\dots$$

$$= -l_1 dS_1 = l_2 dS_2 = -l_3 dS_3 = \dots\dots,$$

the sign being minus or plus according as the angle is obtuse or acute, that is according as the prism is entering or leaving the region of integration.

Hence by putting in the values at the limits (3) becomes

$$\iiint \frac{\partial p}{\partial x} dx dy dz = \iint (p_1 l_1 dS_1 + p_2 l_2 dS_2 + p_3 l_3 dS_3 + \dots)$$

$$= \iint l p dS \text{ over the whole surface } \dots\dots(4)$$

Using this value in (1) we get

$$\iiint \left( \frac{\partial p}{\partial x} - \rho X \right) dx dy dz = 0$$

and two similar equations, and as these integrals must vanish for all ranges of integration, in the fluid, their integrands must be zero at every point; hence

$$\frac{\partial p}{\partial x} = \rho X, \quad \frac{\partial p}{\partial y} = \rho Y, \quad \frac{\partial p}{\partial z} = \rho Z \dots\dots\dots(5)$$

leading to  
as before.

$$dp = \rho (Xdx + Ydy + Zdz)$$

We have made no use of the equations of moments of type (2) but we can shew that they also are satisfied by equations (5). Thus consider for example

$$\iiint y \frac{\partial p}{\partial x} dx dy dz;$$

if we integrate along the same prism as before, observing that *y* is constant along the prism, we get

$$\iint y p dy dz$$

between the limits *P*<sub>1</sub> to *P*<sub>2</sub>, *P*<sub>3</sub> to *P*<sub>4</sub>, &c., and as above this can be seen to be equal to  $\iint p ly dS$  taken over the whole surface; that is, the equation (4) is still true if we insert a factor *y* (or *z*) in the integrand on either side of the equation. By similar arguments it follows that

$$\iint p (ny - mz) dS = \iiint \left( y \frac{\partial p}{\partial z} - z \frac{\partial p}{\partial y} \right) dx dy dz,$$

and if we substitute from (5) this becomes

$$\iiint \rho (yZ - zY) dx dy dz,$$

thus verifying equation (2).

It is to be noted that since a perfect fluid is incapable of resisting shearing stress there can be no such stresses in a mass of fluid in equilibrium, and therefore it follows that the equations obtained by taking moments about the axes will of necessity be satisfied whenever the equations obtained by resolving parallel to the axes are satisfied. For in equilibrium the latter equations are true for any portion of the fluid finite or infinitesimal, and this balancing of forces ensures that the equations of moments are true also.

**24.** We can also prove that  $\rho (Xdx + Ydy + Zdz)$  must be a perfect differential, by considering the equilibrium of a spherical element of fluid.

For the pressures of the fluid on the surface of the element are all in direction of its centre, and therefore the moment of the acting forces about the centre must vanish.

Let  $x, y, z$  be co-ordinates of the centre, and  $x + \alpha, y + \beta, z + \gamma$  of any point inside the small sphere.

Then,  $\rho$  being the density at the centre, the expression  $\Sigma dm (Z\beta - Y\gamma)$  becomes

$$\iiint dad\beta d\gamma \left( \rho + \frac{\partial \rho}{\partial x} \alpha + \frac{\partial \rho}{\partial y} \beta + \frac{\partial \rho}{\partial z} \gamma \right) \left\{ \beta \left( Z + \frac{\partial Z}{\partial x} \alpha + \frac{\partial Z}{\partial y} \beta + \frac{\partial Z}{\partial z} \gamma \right) - \gamma \left( Y + \frac{\partial Y}{\partial x} \alpha + \frac{\partial Y}{\partial y} \beta + \frac{\partial Y}{\partial z} \gamma \right) \right\}.$$

Now  $\iiint adad\beta d\gamma = 0$ , the centre of the sphere being the centre of gravity of the volume,  $\iiint \beta\gamma dad\beta d\gamma = 0$ , &c., and, if  $d\tau = dad\beta d\gamma$ ,

$$\begin{aligned} \iiint \alpha^2 d\tau &= \iiint \beta^2 d\tau = \iiint \gamma^2 d\tau = \frac{1}{3} \iiint (\alpha^2 + \beta^2 + \gamma^2) d\tau \\ &= \frac{1}{3} \cdot \int_0^r 4\pi r'^2 dr' = \frac{4}{15} \pi r^5. \end{aligned}$$

The expression for the moment then becomes, neglecting higher powers of  $\alpha, \beta, \gamma$ ,

$$\left\{ \frac{\partial}{\partial y} (\rho Z) - \frac{\partial}{\partial z} (\rho Y) \right\} \frac{4\pi r^5}{15},$$

and, in order that this may be evanescent, we must have

$$\frac{\partial}{\partial y} (\rho Z) = \frac{\partial}{\partial z} (\rho Y).$$

**25. Fluid at rest under the action of gravity.**

Taking the axis of  $z$  vertical, and measuring  $z$  downwards,

$$X = 0, \quad Y = 0, \quad Z = g,$$

and the equation ( $\alpha$ ) of Art. (15) becomes

$$dp = g\rho dz,$$

an equation which may also be obtained directly by considering the equilibrium of a small vertical cylinder.

In the case of homogeneous liquid,

$$p = g\rho z + C,$$

and the surfaces of equal pressure are horizontal planes.

Hence the free surface is a horizontal plane, and, taking the origin in the free surface, and  $\Pi$  as the external pressure,

$$p = g\rho z + \Pi.$$

If there be no pressure on the free surface,

$$p = g\rho z,$$

or the pressure at any point is proportional to the depth below the surface.

In the case of heterogeneous liquid, the equation

$$dp = g\rho dz$$

shews that  $\rho$  must be a function of  $z$ . The density and pressure are therefore constant for all points in the same horizontal plane.

As an example, let  $\rho \propto z^n = \mu z^n$ ,

then 
$$p = g\mu \frac{z^{n+1}}{n+1} + \Pi.$$

**26.** *If two liquids, which do not mix, meet in a bent tube, the heights of the free surfaces above the common surface are inversely as the densities.*

For the pressures at the common surface are the same, and if  $z, z'$  be the heights of the upper surfaces above the common surface, and  $\rho, \rho'$  the densities, these pressures are respectively

$$g\rho z + \Pi, \quad g\rho' z' + \Pi,$$

and

$$\therefore \frac{z}{z'} = \frac{\rho'}{\rho}.$$

**27.** It is a well-known law that if a system be in equilibrium under the action of gravity and the pressure of smooth surfaces, the equilibrium is stable, if the centre of gravity be in its lowest possible position.

Hence it follows that, in the case of heterogeneous liquid, the density must increase with the depth, for otherwise the equilibrium would be unstable.

Thus, if heterogeneous liquid be poured from one vessel to another, it will settle with the heaviest strata lowest, the law of density of course being changed.

*A quantity of liquid, the density of which is a given function of the depth, is contained in a vessel of given shape; if the liquid be transferred to another vessel, it is required to find the new law of density, each vessel being in the form of a surface of revolution with its axis vertical.*

Measuring  $x$  upwards from the lowest point of the liquid, let  $y = f(x)$  be the generating curve of the first vessel, and  $y = \phi(x)$  of the second.

Then, if the stratum at the height  $x$  in the first vessel correspond to the stratum at the height  $x'$  in the second, we obtain, since the volumes are equal,

$$\int_0^x \{f(\xi)\}^2 d\xi = \int_0^{x'} \{\phi(\xi)\}^2 d\xi,$$

and performing the integrations, we find  $x$  in terms of  $x'$ , and therefore  $\rho$ , which is a given function of  $x$ , becomes a new function of  $x'$ .

Moreover, if  $h$  and  $h'$  be the depths of the liquid in the two vessels,  $h$  is given in terms of  $h'$ , and therefore the density,  $\rho$ , can be found in terms of  $h' - x'$ , the depth.

If the new law of density be given, and it be required to find the shape of the new vessel, we may proceed as follows:

The density being a given function of  $h - x$ , and also of  $h' - x'$ , we can, by equating the two expressions, find  $x$  in terms of  $x'$ .

Also, equating the volumes of corresponding strata, we obtain  $y^2 dx = y'^2 dx'$ , which at once, by substituting for  $x$  its value in terms of  $x'$ , gives the equation required. The value of  $h'$  will be then obtained by equating to each other the whole volumes.

**EXAMPLE (1).** *The density of a liquid in a cylindrical vessel varies as the depth; find the new law of density if the liquid be poured into a conical vessel having its vertex downwards.*

In this case  $\rho = \mu (h - x)$ ,  
 and  $\pi a^2 x = \frac{1}{3} \pi x'^3 \tan^2 a$ ;  
 also  $\pi a'^2 h = \frac{1}{3} \pi h'^3 \tan^2 a$ ;  
 $\therefore \rho = \mu \tan^2 a \frac{h^3 - x'^3}{3a^2} = \frac{\mu \tan^2 a}{3a^2} (3h'^2 z - 3h'z^2 + z^3)$ ,

if  $z$  be the depth.

**EXAMPLE (2).** *A quantity of liquid, the density of which varies as the depth, fills an inverted paraboloid to a given height; it is required to find the shape of a vessel, in the form of a surface of revolution, such that if this liquid be poured into it its density will vary as the square of its depth.*

In this case  $\rho = \mu (h - x) = \mu' (h' - x')^2$ ,  
 $\therefore x = h - \frac{1}{c} (h' - x')^2$ , if  $\mu = \mu' c$ .

The equation  $4ax dx = y^2 dx'$  gives  
 $c^2 y'^2 = 8a (h' - x') \{hc - (h' - x')^2\}$ .

To complete the solution, we must equate the total volumes, and we thereby obtain  $h^2 = ch$  as the necessary relation between  $h'$  and  $c$ .

**28. Elastic fluid at rest under the action of gravity.**

In this case,  $p = k\rho$ ,

and  $\frac{dp}{p} = \frac{g}{k} dz$ ,

$\therefore \log \frac{p}{C} = \frac{gz}{k}$  and  $p = Ce^{\frac{gz}{k}}$ .

The surfaces of equal pressure are in this case also horizontal planes, and the constant  $C$  must be determined by a knowledge of the pressure for a given value of  $z$ , or by some other fact in connection with the particular case.

**EXAMPLE.** A closed cylinder, the axis of which is vertical, contains a given mass of air.

Measuring  $z$  from the top of the cylinder,

$$\rho = \frac{p}{k} = \frac{C}{k} e^{\frac{gz}{k}};$$

if  $M$  be the given mass,  $a$  the radius, and  $h$  the height of the cylinder,

$$M = \int_0^h \rho \pi a^2 dz = \pi a^2 \frac{C}{g} (e^{gh} - 1),$$

whence  $C$  is determined.

**29. Illustrations of the use of the general equation.**

(1) Let a given volume  $V$  of liquid be acted upon by forces

$$-\frac{\mu x}{a^2}, \quad -\frac{\mu y}{b^2}, \quad -\frac{\mu z}{c^2},$$

respectively parallel to the axes;

then 
$$dp = \rho \left( -\frac{\mu x}{a^2} dx - \frac{\mu y}{b^2} dy - \frac{\mu z}{c^2} dz \right),$$

and 
$$p = C - \frac{\mu \rho}{2} \left( \frac{x^2}{a^2} + \frac{y^2}{b^2} + \frac{z^2}{c^2} \right).$$

The surfaces of equal pressure are therefore similar ellipsoids, and the equation to the free surface is

$$\frac{x^2}{a^2} + \frac{y^2}{b^2} + \frac{z^2}{c^2} = \frac{2C}{\mu \rho},$$

assuming that there is no external pressure.

The condition which determines the constant is that the volume of the fluid is given, and we have

$$V = \frac{4}{3} \pi abc \cdot \left( \frac{2C}{\mu \rho} \right)^{\frac{3}{2}},$$

and 
$$C = \frac{\mu \rho}{2} \cdot \left( \frac{3V}{4\pi abc} \right)^{\frac{2}{3}}.$$

(2) A given volume of liquid is at rest on a fixed plane, under the action of a force, to a fixed point in the plane, varying as the distance.

Taking the fixed point as origin, the expression for the pressure at any point is

$$p = C - \frac{1}{2} \mu \rho (x^2 + y^2 + z^2) = C - \frac{1}{2} \mu \rho r^2,$$

where  $r$  is the distance from the origin; and if  $\frac{4}{3} \pi a^3$  be the given volume, the free surface is a hemisphere of radius  $a$ , and

$$p = \frac{1}{2} \mu \rho (a^2 - r^2).$$

The portion of the plane in contact with fluid is a circle of radius  $a$ , and therefore the pressure upon it

$$\begin{aligned} &= \int_0^{2\pi} \int_0^a p r dr d\theta \\ &= \frac{1}{2} \pi \mu \rho a^4. \end{aligned}$$

This result may be written in the form  $\mu^{\frac{2}{3}} a \cdot \frac{4}{3} \pi \rho a^3$ , which is the expression for the attraction on the whole mass of fluid, supposed to be condensed into a material particle at its centre of gravity, and might in fact have been at once obtained by considering that the fluid is kept at rest by the attraction to the centre of force and the reaction of the plane.

(3) *A given volume of heavy liquid is at rest under the action of a force to a fixed point varying as the distance from that point.*

Take the fixed point as origin, and measure  $z$  vertically downwards;

then 
$$X = -\mu x, \quad Y = -\mu y, \quad \text{and} \quad Z = g - \mu z;$$

$$\therefore dp = \rho \{-\mu x dx - \mu y dy + (g - \mu z) dz\},$$

and 
$$\frac{p}{\rho} = C - \mu \frac{x^2 + y^2 + z^2}{2} + gz.$$

The surfaces of equal pressure are spheres, and the free surface, supposing the external pressure zero, is given by the equation

$$x^2 + y^2 + z^2 - \frac{2g}{\mu} z = \frac{2C}{\mu}.$$

The volume of this sphere is

$$\frac{4}{3} \pi \left( \frac{2C}{\mu} + \frac{g^2}{\mu^2} \right)^{\frac{3}{2}};$$

equating this to the given volume, the constant  $C$  is determined, and the pressure at any point is then given in terms of  $r$  and  $z$ .

### Rotating Fluid.

30. If a quantity of fluid revolve uniformly and without any relative displacement of its particles (i.e. as if rigid) about a fixed axis, the preceding equations will enable us to determine the pressure at any point, and the nature of the surfaces of equal pressure.

For, in such cases of relative equilibrium, every particle of the fluid moves uniformly in a circle, and the resultant of the external forces acting on any particle  $m$  of the fluid, and of the fluid pressure upon it, must be equal to a force  $m\omega^2 r$  towards the axis,  $\omega$  being the angular velocity, and  $r$  the distance of  $m$  from the axis; it follows therefore that the external forces, combined with the fluid pressures and forces  $m\omega^2 r$  acting from the axis, form a system in statical equilibrium, to which the equations of the previous articles are applicable.

*A mass of homogeneous liquid, contained in a vessel, revolves uniformly about a vertical axis; required to determine the pressure at any point, and the surfaces of equal pressure.*

Take the vertical axis as the axis of  $z$ ; then, resolving the force  $m\omega^2 r$  parallel to the axes, its components are  $m\omega^2 x$  and  $m\omega^2 y$ , and the general equation of fluid equilibrium becomes

$$dp = \rho (\omega^2 x dx + \omega^2 y dy - g dz),$$

and therefore

$$p = \rho \left\{ \frac{1}{2} \omega^2 (x^2 + y^2) - gz \right\} + C.$$

The surfaces of equal pressure are therefore paraboloids of revolution, and if the vessel be open at the top, the free surface is given by the equation

$$\omega^2 (x^2 + y^2) - 2gz + \frac{2C}{\rho} = \frac{2\Pi}{\rho},$$

where  $\Pi$  is the external pressure.

The constant must be determined by help of the data of each particular case.

For instance, let the vessel be closed at the top and be just filled with liquid, and let  $\Pi = 0$ ; then, taking the origin at the highest point of the axis,  $p = 0$  when  $x, y$  and  $z$  vanish, and therefore  $C = 0$ , and

$$p = \rho \left\{ \frac{1}{2} \omega^2 (x^2 + y^2) - gz \right\}.$$

✓ 31. Next consider the case of elastic fluid enclosed in a vessel which rotates about a vertical axis;

as before

$$dp = \rho \{ \omega^2 (x dx + y dy) - g dz \},$$

and

$$p = k\rho;$$

$$\therefore k \log \rho = \omega^2 \frac{x^2 + y^2}{2} - gz + C,$$

so that the surfaces of equal pressure and density are paraboloids.

Let the containing vessel be a cylinder rotating about its axis, and suppose the whole mass of fluid given; then, to determine the constant, consider the fluid arranged in elementary horizontal rings each of uniform density: let  $r$  be the radius of one of these rings at a height  $z$ ,  $\delta r$  its horizontal and  $\delta z$  its vertical thickness,  $h$  the height, and  $a$  the radius of the cylinder:

$$\text{the mass of the ring} = 2\pi r \delta r \delta z,$$

$$\text{and the whole mass (M) of the fluid} = \int_0^h \int_0^a 2\pi p r dr dz,$$

the origin being taken at the base of the cylinder.

$$\text{Now} \quad \rho = e^{\frac{C}{k}} \cdot e^{\frac{\omega^2 r^2 - 2gz}{2k}};$$

$$\text{and} \quad \therefore M = \frac{2\pi k^2}{g\omega^2} e^{\frac{C}{k}} \left( e^{\frac{\omega^2 a^2}{2k}} - 1 \right) \left( 1 - e^{-\frac{gh}{k}} \right),$$

an equation by which  $C$  is determined.

32. In general the equation of equilibrium for a fluid revolving uniformly and acted upon by forces of any kind is

$$dp = \rho \{Xdx + Ydy + Zdz + \omega^2 (xdx + ydy)\}.$$

In order that the equilibrium may be possible, three equations of condition must be satisfied, expressing that  $dp$  is a perfect differential, and, if these conditions are satisfied, the surfaces of equal pressure, and, in certain cases, the free surface can be determined; but it must be observed that a free surface is not always possible. In fact, in order that there may be a free surface, the surfaces of equal pressure must be symmetrical with respect to the axis of rotation.

EXAMPLES

✓ 1. A closed tube in the form of an ellipse with its major axis vertical is filled with three different liquids of densities  $\rho_1, \rho_2, \rho_3$  respectively. If the distances of the surfaces of separation from either focus be  $r_1, r_2, r_3$  respectively, prove that

$$r_1(\rho_2 - \rho_3) + r_2(\rho_3 - \rho_1) + r_3(\rho_1 - \rho_2) = 0.$$

2. The particles of a given mass of homogeneous liquid at rest attract each other according to the law of nature; find the pressure at any point.

✓ 3. The density of a liquid varies as the square of the depth below the surface; find the pressures, 1st, on a rectangular area just immersed vertically with one side in the surface, 2nd, on a circular area just immersed.

4. A parabolic area, bounded by the latus rectum, is just immersed vertically, with its vertex in the surface of a liquid; find the pressure upon it, 1st, when the liquid is homogeneous, 2nd, when its density varies as the depth.

\* 5. Find the surfaces of equal pressure when the forces tend to fixed centres and vary as the distances from those centres.

6. A regular tetrahedron is filled with fluid, and held so that two of its opposite edges are horizontal; compare the pressures on its several sides with the weight of the fluid.

✓ 7. Prove that if the forces per unit of mass at  $x, y, z$  parallel to the axes are

$$y(a-z), \quad x(a-z), \quad xy,$$

the surfaces of equal pressure are hyperbolic paraboloids and the curves of equal pressure and density are rectangular hyperbolas.

8. In a solid sphere two spherical cavities, whose radii are equal to half the radius of the solid sphere, are filled with liquid; the solid and liquid particles attract each other with forces which vary as the distance: prove that the surfaces of equal pressure are spheres concentric with the solid sphere.

✗ 9. Shew that the forces represented by

$$X = \mu(y^2 + yz + z^2), \quad Y = \mu(z^2 + zx + x^2), \quad Z = \mu(x^2 + xy + y^2)$$

will keep a mass of liquid at rest, if the density  $\propto \frac{1}{(\text{dist.})^2}$  from the plane  $x+y+z=0$ ; and the curves of equal pressure and density will be circles.

10. If a conical cup be filled with liquid, the mean pressure at a point in the volume of the liquid is to the mean pressure at a point in the surface of the cup as 3 : 4.

11. A vessel is in the form of a right cone without weight, the vertical angle being  $2a$ ; the vessel is filled with liquid and then suspended by a point in the rim: if  $\beta$  be the inclination of the axis of the cone to the vertical, shew that

$$\cot 2\beta = \cot 2a - \frac{3}{2} \operatorname{cosec} 2a.$$

12. A mass of fluid rests upon a plane subject to a central attractive force  $\left(\frac{\mu}{r^2}\right)$ , situated at a distance  $c$  from the plane on the side opposite to that on which the fluid is; and  $a$  is the radius of the free spherical surface of the fluid: shew that the pressure on the plane

$$= \frac{\pi \rho \mu}{a} (a - c)^2.$$

13. Find the surfaces of equal pressure for homogeneous fluid acted upon by two forces which vary as the inverse square of the distance from two fixed points.

Prove that if the surface of no pressure be a sphere, the loci of points at which the pressure varies inversely as the distance from one of the centres of force are also spheres.

14. If the components parallel to the axes of the forces acting on an element of fluid at  $(x, y, z)$  be proportional to

$$y^2 + 2\lambda yz + z^2, \quad z^2 + 2\mu zx + x^2, \quad x^2 + 2\nu xy + y^2,$$

shew that if equilibrium be possible we must have

$$2\lambda = 2\mu = 2\nu = 1.$$

15. A mass of fluid is in equilibrium under the forces

$$X = (y + z)^2 - x^2, \quad Y = (z + x)^2 - y^2, \quad Z = (x + y)^2 - z^2.$$

Find the density and prove that the surfaces of equal pressure are hyperboloids of revolution.

16. A fluid rests in equilibrium in a field of force where

$$X = y^2 + z^2 - xy - xz, \quad Y = z^2 + x^2 - zy - xy, \quad Z = x^2 + y^2 - xz - yz;$$

shew that the curves of equal pressure and density are a set of circles.

17. If  $X = y(y + z)$ ,  $Y = z(z + x)$ ,  $Z = y(y - x)$ ,

prove that the curves of equal pressure and density are given by  $y(x + z) = \text{const.}$  and  $y + z = \text{const.}$

18. Find the surfaces of equal pressure when the component forces at any point  $x, y, z$  are  $y(y + z)$ ,  $z(z + x)$  and  $y(y - x)$ ; shewing that they are the hyperbolic paraboloids

$$y(x + z) = c(y + z).$$

19. A fluid is in equilibrium under a given system of forces; if  $\rho_1 = \phi(x, y, z)$ ,  $\rho_2 = \psi(x, y, z)$  be two possible values of the density at any point, shew that the equations of the surfaces of equal pressure in either case are given by

$$\phi(x, y, z) + \lambda \psi(x, y, z) = 0,$$

where  $\lambda$  is an arbitrary parameter.

20. A hollow sphere of radius  $a$ , just full of homogeneous liquid of unit density, is placed between two external centres of attractive force  $\mu^2/r^2$  and  $\mu'^2/r'^2$ , distant  $c$  apart, in such a position that the attractions due to them at the centre are equal and opposite. Prove that the pressure at any point is

$$\mu^2/r + \mu'^2/r' - \mu^{\frac{3}{2}} \mu'^{\frac{3}{2}} (\mu + \mu')^2 / \{(\mu + \mu')^2 a^2 + \mu \mu' c^2\}^{\frac{3}{2}}.$$

21. A sphere, of radius  $c$ , is nearly filled with homogeneous liquid under the influence of two external centres of force situated on a diameter, on opposite sides of the centre and at distances  $a$  and  $a'$  from it. The attraction of each centre of force at any point varies inversely as the square of the distance, and their attractions on the mass of liquid are  $\frac{1}{2}\pi c^3 f$  and  $\frac{1}{2}\pi c^3 f'$ , respectively. Prove that, if  $(f/f')$  lies between  $\frac{a'(a-c)}{a(a'+c)}$  and  $\frac{a'(a+c)}{a(a'-c)}$ , the pressure at the centre is equal to

$$fa + f'a' - \frac{\{aa'(af'^3 + a'f'^3)\}^{\frac{1}{2}}}{\{(c^2 + aa')(a + a')\}^{\frac{1}{2}}}$$

22. The density of a liquid, contained in a cylindrical vessel, varies as the depth; it is transferred to another vessel, in which the density varies as the square of the depth; find the shape of the new vessel.

23. A circular cone, of vertical angle  $\frac{\pi}{2}$ , is just filled with water, and has a generating line rigidly attached to a horizontal plane. The plane is caused to revolve with uniform angular velocity about a vertical axis through the apex of the cone: find the greatest velocity which will allow of the pressure being zero at the highest point; and in this case find the pressure on the base.

24. A straight rod, every particle of which attracts with a force varying inversely as the square of the distance, is surrounded by a mass of homogeneous incompressible fluid; find the form of the surfaces of equal pressure.

25. A quantity of heavy liquid is attracted to a fixed centre, by a constant force the intensity of which is equal to the force of gravity, and is supported by a horizontal plane. Find the form of the surfaces of equal pressure; and also the pressure on the plane, proving that when the plane passes through the centre of force it is equal to four-thirds of the weight of the liquid. Find also expressions for the pressure on the plane when it is either above or below the centre of force.

26. The interior of a homogeneous shell, bounded by two non-concentric spherical surfaces, and attracting according to the law of nature, is partially filled with homogeneous liquid which revolves uniformly with it round the line passing through the centres of the spheres; prove that the free surface is a paraboloid of revolution.

27. A rigid spherical shell is filled with homogeneous inelastic fluid, every particle of which attracts every other with a force varying inversely as the square of the distance; shew that the difference between the pressures at the surface and at any point within the fluid varies as the area of the least section of the sphere through the point.

28. An open vessel containing liquid is made to revolve about a vertical axis with uniform angular velocity. Find the form of the vessel and its dimensions that it may be just emptied.

29. An infinite mass of homogeneous fluid surrounds a closed surface and is attracted to a point ( $O$ ) within the surface with a force which varies inversely as the cube of the distance. If the pressure on any element of the surface about a point  $P$  be resolved along  $PO$ , prove that the whole radial pressure, thus estimated, is constant, whatever be the shape and size of the surface, it being given that the pressure of the fluid vanishes at an infinite distance from the point  $O$ .

30. A vessel formed by the revolution of a cardioid

$$r = a(1 - \cos \theta)$$

about its axis which is vertical (vertex upwards) is just filled with water and rotates about that axis with uniform angular velocity. Find this velocity

when the line of no pressure is given by  $\theta = \frac{\pi}{6}$ . Find also the pressure at any other point, and the points of maximum pressure.

31. All space being supposed filled with an elastic fluid the particles of which are attracted to a given point by a force varying as the distance, and the whole mass of the fluid being given, find the pressure on a circular disc placed with its centre at the centre of force.

32. Circles are drawn having their centres on the axis of  $z$  and touching at the origin the plane  $xy$ , and the position of a point  $P$  is defined by  $r, \theta, \phi$ , where  $r$  is the radius of the circle through  $P$ , centre  $C$ ,  $\theta$  is the angle  $OCP$ , and  $\phi$  the inclination of the plane  $OCP$  to a fixed plane through the axis of  $z$ ; prove that

$$\frac{dp}{\rho} = R(1 - \cos \theta) dr + T \sin \theta dr + Tr d\theta + Nr \sin \theta d\phi,$$

where  $mR, mT, mN$  are the forces, on an element  $m$  of liquid at  $P$ , along  $CP$ , along the tangent to the circle at  $P$ , and perpendicular to the plane of the circle.

33. A mass  $m$  of elastic fluid is rotating about an axis with uniform angular velocity  $\omega$ , and is acted on by an attraction towards a point in that axis equal to  $\mu$  times the distance,  $\mu$  being greater than  $\omega^2$ ; prove that the equation of a surface of equal density  $\rho$  is

$$\mu(x^2 + y^2 + z^2) - \omega^2(x^2 + y^2) = k \log \left\{ \frac{\mu - \omega^2}{8\pi^3} \cdot \frac{m^2}{\rho^2 k^3} \right\}.$$

34. A quantity of liquid, the density of which varies as the depth, fills an inverted paraboloid, of latus rectum  $c$ , to a height  $h$ ; prove that, if it be poured into a vessel of the form generated by the revolution round the axis of  $x$  of the curve,

$$a^2 y^2 = 2ch^2 x(a - x)(2a - x),$$

where  $a$  is any constant, its density will vary as the square of its depth.

35. A mass of self-attracting liquid, of density  $\rho$ , is in equilibrium, the law of attraction being that of the inverse square: prove that the mean pressure throughout any sphere of the liquid, of radius  $r$ , is less by  $\frac{2}{3}\pi\rho^2 r^2$  than the pressure at its centre.

36. A closed hollow right circular cone, standing on its flat base on a horizontal plane, is just filled with a liquid, the density of which varies as the depth. The vessel is then inverted and held with its axis vertical and its vertex on the horizontal plane. Prove that the resultant pressure on the curved surface is unchanged in magnitude, and that the potential energy of the liquid is changed in the ratio

$$2 \left\{ \Gamma\left(\frac{1}{3}\right) \right\}^2 : 3 \Gamma\left(\frac{2}{3}\right),$$

it being assumed that the potential energy is zero when the liquid is let out on the plane.

37. A fluid is slightly compressible according to the law

$$(\rho - \rho_0)/\rho_0 = \beta(p - p_0)/p_0,$$

where  $\beta$  is small: prove that a mass  $\frac{4}{3}\pi\rho_0 a^3$  of the fluid will, under the action of its own gravitation with an external pressure  $p_0$ , assume a spherical form of approximate radius  $a(1 - \frac{1}{15}\beta m\pi a^2 \rho_0^2/p_0)$ , where  $m$  is the constant of gravitation.

38. A mass  $M$  of gas at uniform temperature is diffused through all space, and at each point  $(x, y, z)$  the components of force per unit mass are  $-Ax, -By, -Cz$ . The pressure and density at the origin are  $p_0$  and  $\rho_0$  respectively. Prove that

$$ABC\rho_0 M^2 = 8\pi^2 p_0^3.$$

39. A given mass of air is contained within a closed air-tight cylinder with its axis vertical. The air is rotating in relative equilibrium about the axis of the cylinder. The pressure at the highest point of its axis is  $P$ , and the pressure at the highest points of its curved surface is  $p$ . Prove that, if the fluid were absolutely at rest, the pressure at the upper end of the axis would be  $(p - P)/\{\log p - \log P\}$ ; where the weight of the air is taken into account.

40. A mass of gas at constant temperature is at rest under the action of forces of potential  $\psi$  at any point of space, with any boundary conditions. At the point where  $\psi$  is zero, the pressure is  $\Pi$  and the density  $\rho_0$ . The gas is now removed from the action of the forces and confined in a space so that it is at a uniform density  $\rho_0$ . Prove that the loss of intrinsic potential energy by the gas, due to the expansion, is

$$\rho_0 \iiint \psi e^{-\frac{\rho_0 \psi}{\Pi}} d\sigma;$$

where the integrations are taken throughout the gas in its original state.

41. A given mass  $M$  of elastic fluid, for which  $p = kp$ , is forced into a rigid shell, whose equation is  $x^2/a^2 + y^2/b^2 + z^2/c^2 = 1$ , and assumes equilibrium under a system of forces, whose force function is  $\frac{k}{2} \log(x^2/a^4 + y^2/b^4 + z^2/c^4) + \text{constant}$ . Shew that, if  $p_0$  be the pressure at any point of the surface

$$x^2/a^4 + y^2/b^4 + z^2/c^4 = 1/a^2,$$

the mean pressure estimated for equal elements of mass throughout the shell is

$$\frac{4\pi p_0^2 a^2}{15kM} \left( \frac{bc}{a} + \frac{ca}{b} + \frac{ab}{c} \right).$$

42. Homogeneous heavy liquid is contained in a closed hemispherical vessel of radius  $a$ , having its plane surface horizontal and upwards. The liquid is attracted towards the axis with a force varying inversely as the cube of the distance from the axis, and its volume is such that the free surface meets the hemisphere at an angular distance  $\pi/3$  from the vertex. If the system now rotates round the axis with uniform angular velocity  $\omega$ , the free surface meets the plane face of the vessel along the rim and along a circle of radius  $b$ . Shew that the force at unit distance must be  $\omega^2 a^2 b^2$  and that  $b$  and  $\omega$  are connected by the equation

$$\frac{11g\alpha^3}{6\omega^2} = a^4 - b^4 + 2a^2 b^2 \log \left( \frac{b^2}{a^2} + \frac{3g}{4a\omega^2} \right).$$

43. A uniform spherical mass of liquid of density  $\rho + \sigma$  and radius  $a$  is surrounded by another incompressible liquid of density  $\rho$  and external radius  $b$ . The whole is in equilibrium under its own gravitation, but with no external pressure. Shew that the pressure at the centre is

$$\frac{2}{3} \pi (\rho + \sigma)^2 a^2 + \frac{2}{3} \pi \rho \left\{ \frac{2a^3}{b} \sigma + \rho(a + b) \right\} (b - a).$$

44. A uniform spherical mass of incompressible fluid, of density  $\rho$  and radius  $a$ , is surrounded by another incompressible fluid, of density  $\sigma$  and external radius  $b$ . The total fluid is in equilibrium under its gravitation, but with no external pressure or forces. The two fluids are now mixed into a homogeneous fluid of the same volume, and the mass is again in equilibrium in a spherical form. Prove that the pressure at the centre in the first case exceeds the pressure at the centre in the second case by

$$\frac{8}{3} \pi \sigma (\rho - \sigma) a^2 \left( 1 - \frac{a}{b} \right) \left[ 1 + \frac{1}{4} \left( \frac{\rho}{\sigma} - 1 \right) \left( 1 + \frac{a}{b} \right) \left( 1 + \frac{a^2}{b^2} \right) \right].$$

45. The boundary of a homogeneous gravitating solid, of density  $\sigma$  and mass  $M$ , is the surface  $r = a \{1 + \alpha P_n(\cos \theta)\}$ , where  $\alpha$  is a quantity so small that its square may be neglected. The solid is surrounded by a mass  $M'$  of

gravitating liquid, of density  $\rho$ . Shew that the equation to the free surface is approximately

$$r = b \{1 + \beta P_n(\cos \theta)\},$$

where

$$b^3 = \frac{3}{4\pi} \left( \frac{M'}{\rho} + \frac{M}{\sigma} \right),$$

and

$$\beta = 3(\sigma - \rho) a^{n+3} / \{ (2n-2) \rho b^3 + (2n+1) (\sigma - \rho) a^3 \} b^n.$$

46. A uniform incompressible fluid is of mass  $M$  in gravitational units, and forms a sphere of radius  $a$  when undisturbed under the influence of its own attraction. It is placed in a weak field of force of gravitational potential

$$\sum \mu_n \frac{r^n}{n+1} P_n(\cos \theta), \quad (n > 1),$$

where  $r$  is measured from the centre of the mean spherical surface of the liquid, and the squares of quantities of the type  $\mu_n$  can be neglected. Prove that the equation of the free surface is

$$\frac{r}{a} = 1 + \sum \frac{\mu_n}{M} \frac{2n+1}{2n-2} P_n(\cos \theta).$$

47. Prove that the pressure at the centre of the Earth, if it were a homogeneous liquid, would be  $\frac{1}{2}\rho a$  lb. per square foot, where  $\rho$  is the mass in pounds of a cubic foot of the substance of the Earth and  $a$  is the Earth's radius in feet.

48. The density of a gravitating liquid sphere of radius  $a$  at any point increases uniformly as the point approaches the centre. The surface density is  $\rho_0$  and the mean density is  $\rho$ . Prove that the pressure at the centre is

$$\frac{2}{3}\pi a^2 \{10\rho(\rho - \rho_0) + 3\rho_0^2\}.$$

49. In a gravitating fluid sphere of radius  $a$  the surfaces of equal density are spheres concentric with the boundary, and the density increases from surface to centre according to any law. Prove that the pressure at the centre is greater than it would be if the density were uniform by

$$\frac{8}{3}\pi\gamma \int_0^a (\rho'^2 - \rho^2) r dr,$$

where  $\rho$  denotes the mean density of the whole mass,  $\rho'$  the mean density of that portion which is within a distance  $r$  of the centre, and  $\gamma$  is the constant of gravitation.

## CHAPTER III

### THE RESULTANT PRESSURE OF FLUIDS ON SURFACES

**33.** IN the preceding Chapter we have shewn how to investigate the pressure *at any point* of a fluid at rest under the action of given forces; we now proceed to determine the resultants of the pressures exerted by fluids *upon surfaces* with which they are in contact.

We shall consider, first, the action of fluids on plane surfaces, secondly, of fluids under the action of gravity upon curved surfaces, and thirdly, of fluids at rest under any given forces upon curved surfaces.

#### **Fluid Pressures on Plane Surfaces.**

The pressures at all points of a plane being perpendicular to it, and in the same direction, the resultant pressure is equal to the sum of these pressures.

Hence, if the fluid be incompressible and acted upon by gravity only, the resultant pressure on a plane

$$= \Sigma gpz dA,$$

where  $z$  is the depth of a small element  $dA$  of the area of the plane,

$$= gp\bar{z}A,$$

where  $A$  is the whole area and  $\bar{z}$  the depth of its centroid.

In general, if the fluid be of any kind, and at rest under the action of any given forces, take the axes of  $x$  and  $y$  in the plane, and let  $p$  be the pressure at the point  $(x, y)$ .

The pressure on an element of area  $\delta x \delta y = p \delta x \delta y$ :

$$\therefore \text{the resultant pressure} = \iint p dy dx,$$

the integration extending over the whole of the area considered.

If polar co-ordinates be used, the resultant pressure is given by the expression

$$\iint pr dr d\theta.$$

**34. DEF.** *The centre of pressure is the point at which the direction of the single force, which is equivalent to the fluid pressures on the plane surface, meets the surface.*

The centre of pressure is here defined with respect to plane surfaces only; it will be seen afterwards that the resultant action

of fluid on a curved surface is not always reducible to a single force.

In the case of a heavy fluid, it is clear that the centre of pressure of a horizontal area, the pressure on every point of which is the same, is its centroid; and, since pressure increases with the depth, the centre of pressure of any plane area, not horizontal, is below its centroid.

*To obtain formulæ for the determination of the centre of pressure of any plane area.*

Let  $p$  be the pressure at the point  $(x, y)$ , referred to rectangular axes in the plane,  $x + \delta x, y + \delta y$ , the co-ordinates of an adjacent point,

$\bar{x}, \bar{y}$ , co-ordinates of the centre of pressure.

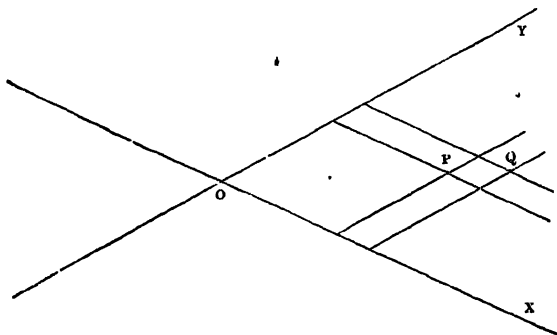

Then  $\bar{y} \cdot \iint p \, dy \, dx =$  moment of the resultant pressure about  $OX$   
 $=$  the sum of the moments of the pressures on  
all the elements of area about  $OX$

$$= \Sigma p \, \delta y \, \delta x \cdot y$$

$$= \iint p y \, dy \, dx;$$

$$\therefore \bar{y} = \frac{\iint p y \, dy \, dx}{\iint p \, dy \, dx},$$

and similarly  $\bar{x} = \frac{\iint p x \, dy \, dx}{\iint p \, dy \, dx},$

the integrals being taken so as to include the area considered.

If polar co-ordinates be employed, a similar process will give the equations

$$\bar{x} = \frac{\iint p r^2 \cos \theta \, dr \, d\theta}{\iint p r \, dr \, d\theta}, \quad \bar{y} = \frac{\iint p r^2 \sin \theta \, dr \, d\theta}{\iint p r \, dr \, d\theta}.$$

35. If the fluid be homogeneous and inelastic, and if gravity be the only force in action,

$$p = gph,$$

where  $h$  is the depth of the point  $P$  below the surface; and we obtain

$$\bar{x} = \frac{\iint hx \, dy \, dx}{\iint h \, dy \, dx}, \quad \bar{y} = \frac{\iint hy \, dy \, dx}{\iint h \, dy \, dx} \dots\dots\dots(\alpha).$$

It is sometimes useful to take for one of the axes the line of intersection of the plane with the surface of the fluid: if we take this line for the axis of  $x$ , and  $\theta$  as the inclination of the plane to the horizon,  $p = gpy \sin \theta$ , and therefore

$$\bar{x} = \frac{\iint xy \, dy \, dx}{\iint y \, dy \, dx}, \quad \bar{y} = \frac{\iint y^2 \, dy \, dx}{\iint y \, dy \, dx} \dots\dots\dots(\beta).$$

From these last equations ( $\beta$ ) it appears that the position of the centre of pressure is independent of the inclination of the plane to the horizon, so that if a plane area be immersed in fluid, and then turned about its line of intersection with the surface as a fixed axis, the centre of pressure will remain unchanged.

If in the equations ( $\alpha$ ) we make  $h$  constant, that is, if we suppose the plane horizontal,  $\bar{x}$  and  $\bar{y}$  are the co-ordinates of the centroid of the area, a result in accordance with Art. (34); but, in the equations ( $\beta$ ), the values of  $\bar{x}$  and  $\bar{y}$  are independent of  $\theta$ , and are therefore unaffected by the evanescence of  $\theta$ . This apparent anomaly is explained by considering that, however small  $\theta$  be taken, the portion of fluid between the plane area and the surface of the fluid is always wedge-like in form, and the pressures at the different points of the plane, although they all vanish in the limit, do not vanish in ratios of equality, but in the constant ratios which they bear to one another for any finite value of  $\theta$ .

The equations of this article may also be obtained by the following reasoning.

Through the boundary line of the plane area draw vertical lines to the surface enclosing a mass of fluid; then the reaction of the plane, resolved vertically, is equal to the weight of the fluid, which acts in a vertical line through its centre of mass; and the point in which this line meets the plane is the centre of pressure.

Taking the same axes, the weight of an elementary prism, acting through the point  $(x, y)$ , is  $gph \, \delta x \, \delta y \, \cos \theta$ , where  $\theta$  is the inclination of the plane to the horizon; and therefore the centre of

these parallel forces acting at points of the plane, is given by the equations

$$\bar{x} = \frac{\iint g \rho h x \cos \theta \, dy \, dx}{\iint g \rho h \cos \theta \, dy \, dx}, \quad \bar{y} = \frac{\iint g \rho h y \cos \theta \, dy \, dx}{\iint g \rho h \cos \theta \, dy \, dx},$$

or

$$\bar{x} = \frac{\iint h x \, dy \, dx}{\iint h \, dy \, dx}, \quad \bar{y} = \frac{\iint h y \, dy \, dx}{\iint h \, dy \, dx}.$$

Hence it appears that the depth of the centre of pressure is double that of the centre of mass of the fluid enclosed.

**36.** The following theorem determines geometrically the position of the centre of pressure for the case of a heavy liquid.

*If a straight line be taken in the plane of the area, parallel to the surface of the liquid and as far below the centroid of the area as the surface of the liquid is above, the pole of this straight line with respect to the momental ellipse at the centroid whose semi-axes are equal to the principal radii of gyration at that point will be the centre of pressure of the area.*

Taking  $A$  for the area, and  $b, a$  for the principal radii of gyration, these are determined by the equations

$$Ab^2 = \iint y^2 \, dx \, dy, \quad Aa^2 = \iint x^2 \, dx \, dy,$$

and the equation of the momental ellipse is

$$\frac{x^2}{a^2} + \frac{y^2}{b^2} = 1,$$

the co-ordinate axes being the principal axes at the centroid.

Let  $\bar{x}, \bar{y}$  be the co-ordinates of the centre of pressure, and

$$x \cos \theta + y \sin \theta = p$$

the equation to the line in the surface;

then

$$\bar{x} = \frac{\iint (p - x \cos \theta - y \sin \theta) x \, dx \, dy}{\iint (p - x \cos \theta - y \sin \theta) \, dx \, dy} = -\frac{a^2}{p} \cos \theta,$$

and similarly,

$$\bar{y} = -\frac{b^2}{p} \sin \theta;$$

$\therefore (\bar{x}, \bar{y})$  is the pole of the line

$$x \cos \theta + y \sin \theta = -p$$

with respect to the momental ellipse.

**37.** *Examples of the determination of centres of pressure.*

(1) *A quadrant of a circle just immersed vertically in a heavy homogeneous liquid, with one edge in the surface.*

If  $Ox$ , the edge in the surface, be the axis of  $x$ ,

$$\bar{x} = \frac{\int_0^a \int_0^{\sqrt{a^2-x^2}} xy \, dy \, dx}{\int_0^a \int_0^{\sqrt{a^2-x^2}} y \, dy \, dx}, \quad \bar{y} = \frac{\iint y^2 \, dy \, dx}{\iint y \, dy \, dx},$$

the limits of the integrations for  $\bar{y}$  being the same as for  $\bar{x}$ .

$$\begin{aligned} \iint y \, dx \, dy &= \frac{1}{2} \int (a^2 - x^2) \, dx = \frac{1}{3} a^3, \\ \iint xy \, dx \, dy &= \frac{1}{2} \int x \cdot (a^2 - x^2) \, dx = \frac{1}{8} a^4, \\ \iint y^2 \, dx \, dy &= \frac{1}{3} \int (a^2 - x^2)^{\frac{3}{2}} \, dx = \frac{\pi a^4}{16}; \\ \therefore \bar{x} &= \frac{3}{8} a, \quad \bar{y} = \frac{3}{16} \pi a. \end{aligned}$$

Employing polar co-ordinates and taking the line  $Ox$  as the initial line, we should have  $p = gpr \sin \theta$ , and

$$\bar{x} = \frac{\int_0^{\frac{\pi}{2}} \int_0^a r^3 \cos \theta \sin \theta \, dr \, d\theta}{\iint r^2 \sin \theta \, dr \, d\theta} = \frac{3}{8} a, \quad \text{and} \quad \bar{y} = \frac{\int_0^{\frac{\pi}{2}} \int_0^a r^3 \sin^2 \theta \, dr \, d\theta}{\iint r^2 \sin \theta \, dr \, d\theta} = \frac{3}{16} \pi a.$$

(2) *A circular area, radius  $a$ , is immersed with its plane vertical, and its centre at a depth  $c$ .*

Take the centre as the origin, and the vertical downwards from the centre as the initial line; then if  $p$  be the pressure at the point  $(r, \theta)$ ,

$$p = g\rho(c + r \cos \theta),$$

and the depth below the centre of the centre of pressure

$$= \frac{2 \int_0^{\pi} \int_0^a r^2 \cos \theta (c + r \cos \theta) \, dr \, d\theta}{2 \iint r (c + r \cos \theta) \, dr \, d\theta} = \frac{a^2}{4c}.$$

It will be seen that this result is at once given by the theorem of Art. (36).

(3) *A vertical rectangle, exposed to the action of the atmosphere at a constant temperature.*

If  $\Pi$  be the atmospheric pressure at the base of the rectangle, the pressure at a height  $z$  is  $\Pi e^{-\frac{gz}{k}}$ , Art. (28), and if  $b$  denote the breadth, the pressure upon a horizontal strip of the rectangle

$$= \Pi e^{-\frac{gz}{k}} b \, dz,$$

$\therefore$  the resultant pressure, if  $a$  be the height,

$$= \int_0^a \Pi e^{-\frac{gz}{k}} b \, dz = \Pi \frac{bk}{g} (1 - e^{-\frac{ga}{k}}),$$

and the height of the centre of pressure

$$= \frac{\int_0^a z e^{-\frac{gz}{k}} \, dz}{\int_0^a e^{-\frac{gz}{k}} \, dz} = \frac{k}{g} - \frac{a}{e^{\frac{ga}{k}} - 1}.$$

(4) A hollow cube is very nearly filled with liquid, and rotates uniformly about a diagonal which is vertical; required to find the pressures upon, and the centres of pressure of, its several faces.

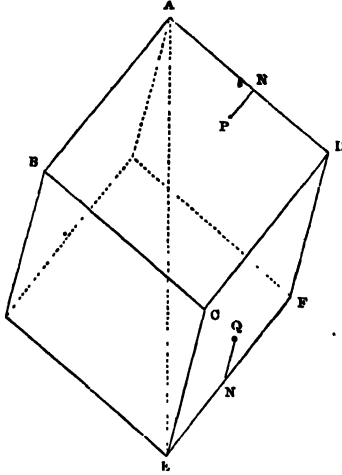

I. For one of the upper faces  $ABCD$ ,

take  $AD$ ,  $AB$ , as axes of  $x$  and  $y$ ;  $z$ ,  $r$ , the vertical and horizontal distances of any point  $P(x, y)$  from  $A$ ,

then

$$\rho = \frac{1}{2}\omega^2 r^2 + gz,$$

$$z = \frac{x+y}{\sqrt{3}}, \text{ projecting the broken line } ANP \text{ on } AE,$$

$$r^2 = AP^2 - z^2 = x^2 + y^2 - z^2 = \frac{2}{3}(x^2 + y^2 - xy);$$

$$\therefore \text{ the pressure } (P) \text{ on } ABCD = \int_0^a \int_0^a \rho \, dy \, dx$$

$$= \rho \cdot \int \int \left\{ \frac{\omega^2}{3}(x^2 + y^2 - xy) + \frac{g}{\sqrt{3}}(x+y) \right\} dy \, dx$$

$$= \rho \left\{ \frac{5}{36} a^4 \omega^2 + \frac{g}{\sqrt{3}} a^3 \right\}.$$

The centre of pressure is given by the equations

$$\bar{x}P = \bar{y}P = \rho \int_0^a \int_0^a x \left\{ \frac{\omega^2}{3}(x^2 + y^2 - xy) + \frac{g}{\sqrt{3}}(x+y) \right\} dy \, dx;$$

$$\therefore \bar{x} = \bar{y} = a \cdot \frac{21g + 3\sqrt{3}\omega^2 a}{36g + 5\sqrt{3}\omega^2 a}.$$

II. For one of the lower faces  $ECDF$ ,

take  $EF$ ,  $EC$  as axes, then, for a point  $Q$ ,

$$z = a\sqrt{3} - \frac{x+y}{\sqrt{3}},$$

$$r^2 = \frac{2}{3}(x^2 + y^2 - xy),$$

and the rest of the process is the same as in the first case.

(5) *A quadrant of a circle is just immersed vertically, with one edge in the surface, in a liquid, the density of which varies as the depth.*

Taking  $Ox$  as the edge in the surface,  $\rho = \mu y$  and  $p = \frac{1}{2} \mu g y^2$ ; the centre of pressure is therefore given by the equations

$$\bar{x} = \frac{\int_0^a \int_0^{\sqrt{a^2-x^2}} xy^2 dy dx}{\iint y^2 dy dx}, \text{ and } \bar{y} = \frac{\iint y^3 dy dx}{\iint y^2 dy dx};$$

or, in polar co-ordinates,

$$x = \frac{\int_0^{\frac{\pi}{2}} \int_0^a r^4 \sin^2 \theta \cos \theta dr d\theta}{\iint r^3 \sin^2 \theta dr d\theta}, \text{ and } \bar{y} = \frac{\iint r^4 \sin^3 \theta dr d\theta}{\iint r^3 \sin^2 \theta dr d\theta};$$

and it will be found that

$$\bar{x} = \frac{16}{15} \frac{a}{\pi} \text{ and } \bar{y} = \frac{32}{15} \frac{a}{\pi}.$$

(6) *A semicircular area completely immersed in water with its plane vertical and one end A of its bounding diameter in the surface.*

Let  $\alpha$  be the inclination of the diameter to the surface, and  $x, y$  the co-ordinates of the centre of pressure referred to the diameter and the tangent at A.

Then  $x \iint r^2 \sin(\theta + \alpha) dr d\theta = \iint r^2 \cos \theta \sin(\theta + \alpha) dr d\theta,$   
 and  $y \iint r^2 \sin(\theta + \alpha) dr d\theta = \iint r^2 \sin \theta \sin(\theta + \alpha) dr d\theta,$

$r$  being taken from 0 to  $2a \cos \theta$ , and  $\theta$  from 0 to  $\frac{\pi}{2}$ .

**38.** If a given plane area turn in its own plane about a fixed point, the centre of pressure changes its position and describes a curve on the area.

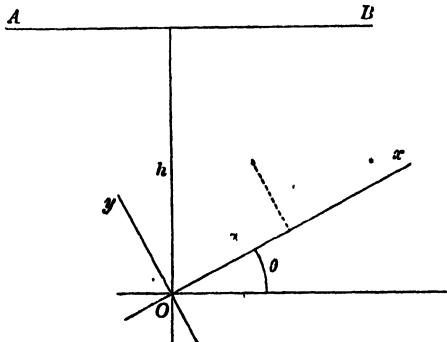

If  $AB$  is the line of intersection of the plane area with the surface, the distance of the centre of pressure from  $AB$  is independent of the inclination of the area to the vertical (Art. 35).

We may therefore take the area to be vertical.

Let  $h$  be the depth of the fixed point  $O$ , and let  $Ox, Oy$  be axes fixed in the area.

Then, if  $\theta$  is the inclination of  $Ox$  to the horizontal,

$$p = g\rho (h - x \sin \theta - y \cos \theta).$$

$$\therefore \bar{x} = \frac{\iint p x dx dy}{\iint p dx dy} = \frac{a + b \sin \theta + c \cos \theta}{d + e \sin \theta + f \cos \theta},$$

and

$$\bar{y} = \frac{a' + b' \sin \theta + c' \cos \theta}{d + e \sin \theta + f \cos \theta},$$

$a, b, d$ , &c. being known constants, and the elimination of  $\theta$  gives a conic section as the locus of the centre of pressure.

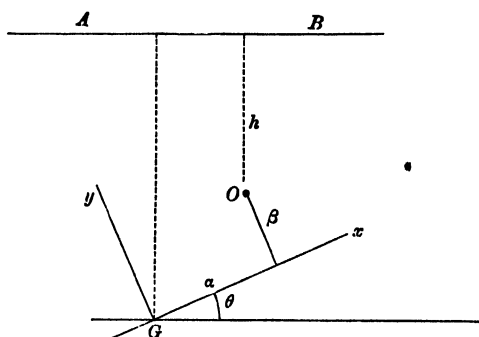

We can also obtain this result by the theorem of Art. (36).

Taking the principal axes through  $G$  as co-ordinate axes, and taking  $\alpha, \beta$  as the co-ordinates of  $O$ , the centre of pressure is the pole  $(\xi, \eta)$  of the line

$$x \sin \theta + y \cos \theta = -(h + \alpha \sin \theta + \beta \cos \theta)$$

with regard to the momental ellipse, and is given by the equations

$$\frac{a^2 \sin \theta}{\xi} = \frac{b^2 \cos \theta}{\eta} = -(h + \alpha \sin \theta + \beta \cos \theta),$$

leading to the equations

$$\left(\frac{a^2}{\xi} + \alpha\right) \sin \theta + \beta \cos \theta = -h,$$

$$\left(\frac{b^2}{\eta} + \beta\right) \cos \theta + \alpha \sin \theta = -h.$$

Eliminating, first,  $\sin \theta$ , and secondly,  $\cos \theta$ , and squaring and adding the results, we obtain the equation of the locus, which is

$$(a^2 b^2 + ab^2 \xi + \beta a^2 \eta)^2 = h^2 (a^4 \eta^2 + b^4 \xi^2).$$

If  $O$  and  $G$  coincide, that is, if  $\alpha = 0$  and  $\beta = 0$ , the locus is

$$\frac{\xi^2}{a^4} + \frac{\eta^2}{b^4} = \frac{1}{h^2}.$$

39. *A vessel having a plane base and plane vertical sides, contains two liquids which do not mix; to find the resultant pressure on one of the sides, and the centre of pressure.*

Let  $\rho$  be the density and  $h$  the depth of the upper liquid,  $\rho', h'$ , corresponding quantities for the lower liquid; the common surface must be a horizontal plane, the pressure at any point of which is  $g\rho h$ , and the pressure at a depth  $z$  below the common surface is

$$g\rho h + g\rho'z.$$

Taking  $b$  for the breadth of one of the vertical sides, the pressure of the upper liquid upon it =  $\frac{1}{2}g\rho bh^2$ , and the pressure of the lower liquid

$$= \int_0^{h'} g(\rho h + \rho'z) b dz = gbh'(\rho h + \frac{1}{2}\rho'h').$$

The resultant pressure is the sum of these two and is equal to

$$gb(\frac{1}{2}\rho h^2 + \rho h h' + \frac{1}{2}\rho'h'^2).$$

The moment of the fluid pressure on this side about its line of intersection with the surface

$$= \int_0^h g\rho b z^2 dz + \int_0^{h'} g(\rho h + \rho'z) b (h + z) dz :$$

performing the integrations, and dividing by the expression for the resultant pressure investigated above, we obtain the depth of the centre of pressure.

**Resultant Pressures on Curved Surfaces.**

40. *To find the resultant vertical pressure on any surface of a homogeneous liquid at rest under the action of gravity.*

$PQ$  being a surface exposed to the action of a heavy liquid, let  $AB$  be the projection of  $PQ$  on the surface of the liquid.

The mass  $AQ$  is supported by the horizontal pressure of the liquid and by the reaction of  $PQ$ ; this reaction resolved vertically must be equal to the weight of  $AQ$ , and conversely, the vertical pressure on  $PQ$  is equal to the weight of  $AQ$ , and acts through its centre of mass.

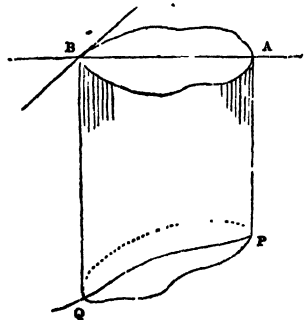

If  $PQ$  be pressed upwards by the liquid as in the next figure, produce the surface, project  $PQ$  on

it as before, suppose the space  $AQ$  to be filled with liquid of the same kind, and remove the liquid from the inside.

Then the pressures at all points of  $PQ$  are the same as before, but in the contrary direction, and since the vertical pressure in this hypothetical case is equal to the weight of  $AQ$ , it follows that in the actual case, the resultant vertical pressure upwards is equal to the weight of  $AQ$ .

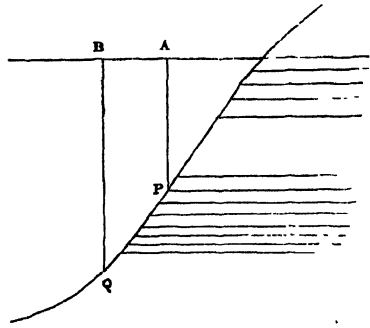

If the surface be pressed partially upwards and partially downwards, draw through  $P$ , the highest point of the portion of surface considered, a vertical plane  $PR$ , and let  $ACB$  be the projection of  $PSQ$  on the surface of the liquid.

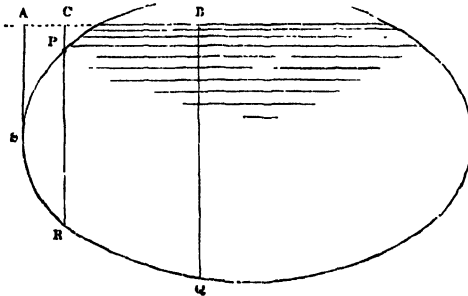

Then the resultant vertical pressure on  $PSR$

= the weight of the liquid in  $PSR$ ,

and on  $RQ$  = .....  $CQ$ ,

and the whole vertical pressure = the weight of the liquid in  $CQ$  + the weight of the liquid in  $PSR$ .

This might also have been deduced from the two previous articles, for  $PR$  can be divided by the line of contact of vertical tangent planes into two portions  $PS$ ,  $SR$ , on which the pressures are respectively upwards and downwards; and since

pressure on  $PS$  = weight of liquid  $APS$ ,

and.....  $SR$  = .....  $ASR$ ,

the difference of these, i.e. the vertical pressure on  $PSR$  = weight of fluid  $PSR$ .

In a similar manner other cases may be discussed.

It will be observed that this investigation applies also to the case of a heterogeneous liquid (in which the density must be a function of the depth, since surfaces of equal pressure are surfaces of equal density), provided we consider that the hypothetical extension of the liquid follows the same law of density.

41. *To find the resultant horizontal pressure, in a given direction, on a surface PQ.*

Project  $PQ$  on a vertical plane perpendicular to the given direction, and let  $pq$  be the projection.

Then the mass  $Pq$  is kept at rest by the pressure on  $pq$ , the resultant horizontal pressure on  $PQ$ , and forces in vertical planes parallel to the plane  $pq$ .

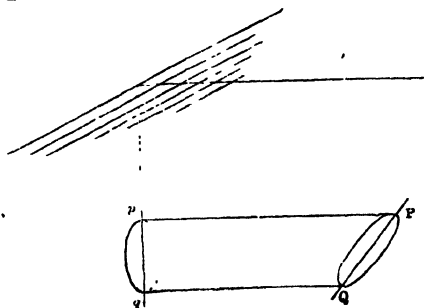

Hence the horizontal pressure on  $PQ$  is equal to that on  $pq$ , and acts in the same straight line, i.e. through the centre of pressure of  $pq$ .

Hence, in general, to determine the resultant fluid pressure on any surface, find the vertical pressure, and the resultant horizontal pressures in two directions at right angles to each other. These three forces may in some cases be compounded into a single force, the condition for which may be determined by the usual methods of Statics.

*Ex. A hemisphere is filled with homogeneous liquid: required to find the resultant action on one of the four portions into which it is divided by two vertical planes through its centre at right angles to each other.*

Taking the centre  $O$  as origin, the bounding horizontal radii as axes of  $x$  and  $y$ , and the vertical radius as the axis of  $z$ , the pressure parallel to  $x$  is equal to the pressure on the quadrant  $yOz$ , which is the projection, on a plane perpendicular to  $Ox$ , of the curved surface.

Therefore, the pressure parallel to  $Ox$

$$= g\rho \frac{\pi a^2}{4} \cdot \frac{4a}{3\pi} = \frac{1}{3} g\rho a^3,$$

and the co-ordinates of its point of action are

$$(0, \frac{3}{8}a, \frac{3}{8}\pi a), \text{ Art. (37), Ex. 1;}$$

similarly, the pressure parallel to  $Oy = \frac{1}{8}g\rho a^3$ , and acts through the point

$$(\frac{3}{8}a, 0, \frac{3}{8}\pi a).$$

The resultant vertical pressure = the weight of the liquid =  $\frac{1}{8}g\rho\pi a^3$ , and acts in the direction of the line  $x = y = \frac{3}{8}a$ .

The directions of the three forces all pass through the point

$$(\frac{3}{8}a, \frac{3}{8}a, \frac{3}{8}\pi a),$$

and they are therefore equivalent to a single force .

$$\frac{1}{8}g\rho a^3 \sqrt{(\pi^2 + 8)}$$

in the line  $x - \frac{3}{8}a = y - \frac{3}{8}a = \frac{2}{\pi} \left( z - \frac{3}{16}\pi a \right),$

or  $x = y = \frac{2}{\pi} z,$

a straight line through the centre, as must obviously be the case, since all the fluid pressures are normal to the surface. The point in which it meets the surface of the hemisphere may be called 'the centre of pressure.'

**42.** *To find the resultant pressure on the surface of a solid either wholly or partially immersed in a heavy liquid.*

Suppose the solid removed, and the space it occupied filled with liquid of the same kind; the resultant pressure upon it will be the same as upon the original solid. But the liquid mass is at rest under the action of its own weight, and the pressure of the liquid surrounding it: the resultant pressure is therefore equal to the weight of the liquid displaced, and acts in a vertical line through its centre of mass.

The same reasoning evidently shews that the resultant pressure of an elastic fluid on any solid is equal to the weight of the elastic fluid displaced by the solid.

This result may also be obtained by means of Arts. (40) and (41), as follows: Draw parallel horizontal lines touching the surface, and forming a cylinder which encloses it; the curve of contact divides the surface into two parts, on which the resultant horizontal pressures, parallel to the axis of the cylinder, are equal and opposite; the horizontal pressures on the solid therefore balance each other and the resultant is wholly vertical. To determine the amount of the resultant vertical pressure, draw parallel vertical lines touching the surface, and dividing it into two portions on one of which the resultant vertical pressure acts upwards, and on the other downwards; the difference of the two is evidently the weight of the fluid displaced by the solid.

**43.** If a solid of given volume ( $V$ ) be completely immersed in a heavy liquid, and if the surface of the solid consist partly of a curved surface, and partly of known plane areas; the resulting pressure on the curved surface can be determined.

For the plane areas being known in size and position, we can calculate the resultant horizontal and the resultant vertical pressure,  $X$  and  $Y$ , upon those areas; and, since the resulting pressure on the whole surface is vertical and equal to  $g\rho V$  upwards, it follows that the resultant horizontal and vertical pressures on the curved surface are respectively equal to  $X$  and  $g\rho V - Y$ .

*Ex.* A solid is formed by turning a circular area round a tangent line through an angle  $\theta$ , and this solid is held under water with its lower plane face horizontal and at a given depth  $h$ .

In this case,

$$V = \pi a^2 \theta, \quad X = g\rho \pi a^2 (h - a \sin \theta) \sin \theta,$$

and

$$Y = g\rho \pi a^2 (h - h \cos \theta + a \sin \theta \cos \theta).$$

**44.** To find the resultant pressure on any surface of a fluid at rest under the action of any given forces.

Let  $p$  be the pressure, determined as in Chapter II., at any point  $(x, y, z)$  of a surface,  $u = 0$ , exposed to the action of a fluid. Then if

$$\frac{1}{P^2} = \left(\frac{\partial u}{\partial x}\right)^2 + \left(\frac{\partial u}{\partial y}\right)^2 + \left(\frac{\partial u}{\partial z}\right)^2,$$

$$P \frac{\partial u}{\partial x}, \quad P \frac{\partial u}{\partial y}, \quad P \frac{\partial u}{\partial z}$$

are the direction-cosines of the normal at the point  $(x, y, z)$ .

Let  $\delta S$  be an element of the surface about the same point. The pressures on this element, parallel to the axes, are

$$pP \frac{\partial u}{\partial x} \delta S, \quad pP \frac{\partial u}{\partial y} \delta S, \quad pP \frac{\partial u}{\partial z} \delta S;$$

$\therefore$  if  $X, Y, Z$ , and  $L, M, N$ , be the resultant pressures parallel to the axes, and the resultant couples, respectively,

$$X = \iint pP \frac{\partial u}{\partial x} dS, \quad Y = \iint pP \frac{\partial u}{\partial y} dS, \quad Z = \iint pP \frac{\partial u}{\partial z} dS,$$

$$L = \iint pP \left( y \frac{\partial u}{\partial z} - z \frac{\partial u}{\partial y} \right) dS,$$

$$M = \iint pP \left( z \frac{\partial u}{\partial x} - x \frac{\partial u}{\partial z} \right) dS,$$

$$N = \iint pP \left( x \frac{\partial u}{\partial y} - y \frac{\partial u}{\partial x} \right) dS;$$

the integrations being made to include the whole of the surface under consideration.

These resultants are equivalent to a single force if

$$XL + YM + ZN = 0.$$

45. The surface may be divided into elements in three different ways by planes parallel to the co-ordinate planes.

Thus,  $\delta x \delta y =$  projection of  $\delta S$  on  $xy = P \frac{\partial u}{\partial z} \delta S$ ;

and  $\therefore Z = \iint p dx dy$ ; and similarly,  $X = \iint p dy dz$ , and  $Y = \iint p dz dx$ ,

$$L = \iint p (y dx dy - z dz dx)$$

$$= \iint p (y dy - z dz) dx,$$

$$M = \iint p (z dz - x dx) dy,$$

$$N = \iint p (x dx - y dy) dz.$$

46. If the fluid be at rest under the action of gravity only, and the axis of  $z$  be vertical,  $p$  is a function of  $z$ ,  $\phi(z)$  suppose, and therefore

$$X = \iint \phi(z) dy dz,$$

which is evidently the expression for the pressure, parallel to  $x$ , upon the projection of the given surface on the plane  $yz$ ; and similarly  $Y$  is equal to the pressure upon the projection on  $xz$ .

Again, if the fluid be incompressible and acted upon by gravity only,  $p \delta x \delta y$  is equal to the weight of the portion of fluid contained between  $\delta S$  and its projection on the surface of the fluid;

$\therefore Z$ , or  $\iint p dx dy$ , is the weight of the superincumbent fluid.

These results accord with those previously obtained, Arts. (40) and (41).

47. If a solid body be wholly or partially immersed in any fluid which is at rest under the action of given forces, the resultant fluid pressure on the body will be equal to the resultant of the forces which would act on the displaced fluid.

For we can imagine the solid removed and the gap filled up with the fluid, which will be in equilibrium under the action of the forces and the pressure of the surrounding fluid; and the resultant pressure must be equal and opposite to the resultant of the forces.

In filling up the gap with fluid, the law of density must be maintained, that is, the surfaces of equal density must be continuous with those of the surrounding fluid.

## EXAMPLES

### EXAMPLES

1. A heavy thick rope, the density of which is double the density of water, is suspended by one end, outside the water, so as to be partly immersed; find the tension of the rope at the middle of the immersed portion.

2. A hollow sphere of radius  $a$  is just filled with water; find the resultant vertical pressures on the two portions of the surface divided by a plane at depth  $c$  below the centre.

3. A vessel in the form of a regular pyramid, whose base is a plane polygon of  $n$  sides, is placed with its axis vertical and vertex downwards and is filled with fluid. Each side of the vessel is moveable about a hinge at the vertex, and is kept in its place by a string fastened to the middle point of its base and to the centre of the polygon; shew that the tension of each string is to the whole weight of the fluid as  $1$  to  $n \sin 2\alpha$ , where  $\alpha$  is the inclination of each side to the horizon.

4. If an area is bounded by two concentric semicircles with their common bounding diameter in the free surface, prove that the depth of the centre of pressure is

$$\frac{3}{8}\pi (a+b) (a^2+b^2); (a^2+b^2+ab),$$

where  $a$  and  $b$  are the radii.

5. Find the centre of pressure of a square lamina having one angular point in the surface of a liquid; and supposing it to be moved about the angular point in its own plane, which is fixed, and to be always totally immersed, find the locus on its own plane of its centre of pressure.

6. Find the centre of pressure of an elliptic lamina just immersed in water; and supposing it turned round in the same vertical plane, so as to be always just immersed, find the locus with respect to its axes of the centre of pressure.

7. A cubical box, filled with water, has a close-fitting heavy lid fixed by smooth hinges to one edge; compare the tangents of the angles through which the box must be tilted about the several edges of its base, in order that the water may just begin to escape.

8. A system of coaxial circles is immersed in water with the line of centres at a given depth; prove that the centres of pressure of those circular areas, which are completely immersed, lie on a parabola.

9. Find the centre of pressure of a semi-ellipse (axes  $2a$  and  $a$ ) which is bounded by a diameter inclined at the angle  $\frac{\pi}{6}$  to its major axis, its plane being vertical, and the diameter in the surface.

10. A semi-ellipse, bounded by its axis minor, is just immersed in a liquid the density of which varies as the depth; if the minor axis be in the surface, find the eccentricity in order that the focus may be the centre of pressure.

11. A square lamina  $ABCD$ , which is immersed in water, has the side  $AB$  in the surface; draw a line  $BE$  to a point  $E$  in  $CD$  such that the pressures on the two portions may be equal. Prove that, if this be the case, the distance between the centres of pressure : the side of the square  $:: \sqrt{505} : 48$ .

12. From a semicircle, whose diameter is in the surface of a liquid, a circle is cut out, whose diameter is the vertical radius of the semicircle; find the centre of pressure of the remainder.

13. A semicircular lamina is completely immersed in water with its plane vertical, so that the extremity  $A$  of its bounding diameter is in the surface, and the diameter makes with the surface an angle  $a$ . Prove that if  $E$  be the centre of pressure and  $\theta$  the angle between  $AE$  and the diameter,

$$\tan \theta = \frac{3\pi + 16 \tan a}{16 + 15\pi \tan a}$$

14. If the depths of the angular points of a triangle below the surface of a liquid be  $a, b, c$ , prove that the depth of the centre of pressure below the centre of gravity is

$$\frac{(b-c)^2 + (c-a)^2 + (a-b)^2}{12(a+b+c)}$$

15. A plane area immersed in a fluid moves parallel to itself and with its centre of gravity always in the same vertical straight line. Shew (1) that the locus of the centres of pressure is a hyperbola, one asymptote of which is the given vertical, and (2) that if  $a, a+h, a+h', a+h''$  be the depths of the c.g. in any positions,  $y, y+k, y+k', y+k''$  those of the centre of pressure in the same positions, then

$$\begin{vmatrix} k & h & h(k-h) \\ k' & h' & h'(k'-h') \\ k'' & h'' & h''(k''-h'') \end{vmatrix} = 0.$$

16. Find the centre of pressure of a segment of a parabola bounded by the curve and the latus-rectum, the tangent at one end of the bounding ordinate being in the surface. If the liquid rise, the parabola remaining stationary, shew that the centre of pressure describes a straight line.

17. A cone is totally immersed in water, the depth of the centre of its base being given. Prove that,  $P, P', P''$  being the resultant pressures on its convex surface, when the sines of the inclination of its axis to the horizon are  $s, s', s''$ , respectively,

$$P^2(s'-s'') + P'^2(s'-s) + P''^2(s-s') = 0.$$

18. Find the centre of pressure of the area between the curve  $\sqrt{x} + \sqrt{y} = \sqrt{a}$  and the axes, taking the axes rectangular and one of them in the surface.

19. A quantity of liquid acted upon by a central force varying as the distance is contained between two parallel planes; if  $A, B$  be the areas of the planes in contact with the fluid, shew that the pressures upon them are in the ratio  $A^2 : B^2$ .

20. A solid sphere rests on a horizontal plane and is just totally immersed in a liquid. It is then divided by two planes drawn through its vertical diameter perpendicular to each other. Prove that if  $\rho$  be the density of the solid,  $\sigma$  that of the fluid, the parts will not separate provided  $\sigma > \frac{1}{4}\rho$ .

21. One asymptote of a hyperbola lies in the surface of a fluid; find the depth of the centre of pressure of the area included between the immersed asymptote, the curve, and two given horizontal lines in the plane of the hyperbola.

22. A cone is immersed in water with the centre of its base at a distance of  $\frac{1}{3}$  of its altitude below the surface. A paraboloid of the same base and altitude is also immersed with the centre of its base at the same distance below the surface as that of the cone, and with its axis inclined at the same angle to the vertical. Find what this angle must be in order that the resultant pressures on the convex surfaces of the two solids may be equal.

23. A closed cylinder, very nearly filled with liquid, rotates uniformly about a generating line, which is vertical; find the resultant pressure on its curved surface.

Determine also the point of action of the pressure on its upper end.

24. Shew that the depth of the centre of pressure of the area included between the arc and the asymptote of the curve

$$(r - a) \cos \theta = b \text{ is } \frac{a}{4} \cdot \frac{3\pi a + 16b}{3\pi b + 4a},$$

the asymptote being in the surface and the plane of the curve vertical.

25. A cone is filled with liquid, and fitted with a heavy lid, moveable about a hinge; it is then made to revolve uniformly about the generating line through the hinge, which is vertical; find the greatest angular velocity consistent with no escape of the liquid.

26. A portion of a spherical shell is cut off by a plane, and the remaining portion is placed on a horizontal plane so that the circular section is in contact with the plane and is then filled with water through a small hole at the highest point. Find the largest piece which can be cut off so that, however light the shell may be, the water may not escape.

In this case, prove that the whole pressure on the shell is to the weight of the liquid in the ratio 2 : 1.

27. If a plane area immersed in a liquid revolve about any axis in its own plane, prove that the centre of pressure describes a straight line in the plane.

28. A cube whose edge is  $2a$ , and whose faces are horizontal and vertical, is surrounded by a mass of heavy liquid, the volume of which is  $8a^3 \{ \pi \sqrt{6} - 1 \}$ ; the liquid is acted on by a force tending to the centre of the cube, and varying as the distance, the force at the distance  $a$  being  $g$ : find the form of the free surface and the pressure at any point: also if one of the vertical faces of the cube be moveable about a horizontal line in its own plane, shew that the face will be at rest, if this line be at a distance  $\frac{1}{2}a$  from the lowest edge of that face.

29. A solid paraboloid, cut off by a plane through the focus perpendicular to its axis, is completely immersed, its vertex being at a given depth, and its axis inclined at a given angle to the vertical. Find the direction and magnitude of the resultant pressure on its curved surface.

30. A solid is formed by turning a parabolic area, bounded by the latus-rectum, about the latus-rectum, through an angle  $\theta$ ; and this solid is held under water, just immersed, with its lower plane face horizontal. Prove that, if  $\phi$  be the inclination to the horizon of the resultant pressure on the curved surface of the solid,

$$3 \sin^2 \theta \tan \phi = 5 \sin \theta - 3 \sin \theta \cos \theta - 2\theta.$$

31. In the midst of a mass of fluid attracting according to the law of nature, and rotating in relative equilibrium about an axis, a small particle is introduced, and started with the velocity of the fluid whose place it occupies. Will it approach or recede from the axis?

32. In an infinite mass of fluid of density  $\rho$ , every part of which attracts every other part according to the law of nature, are placed two shells, whose internal and external radii are  $a, b$  and  $a', b'$  respectively, and densities  $\sigma, \sigma'$ . The shells also attract each other and the fluid as in nature. Find the resultant force on each shell, and shew that in certain cases this force is a repulsive one.

33. A given area is immersed vertically in a heavy liquid and a cone is constructed on it as base, the cone being wholly immersed: find the locus of the vertex when the resultant pressure on the curved surface is constant, and shew that this pressure is unaltered by turning the cone round the horizontal line drawn through the centre of gravity of the base perpendicular to the plane of the base.

34. A conical vessel, axis vertical and vertex downwards, is divided into two parts by a plane through its axis, and the parts are prevented from separating by a string which is a diameter of the rim of the vessel, and is perpendicular to the dividing plane, and by a hinge at the vertex. The vessel being filled with water, compare the tension of the string with the weight of the water.

35. A hollow cone open at the top is filled with water; find the resultant pressure on the portion of its surface cut off, on one side, by two planes through its axis inclined at a given angle to each other; also determine the line of action of the resultant pressure, and shew that, if the vertical angle be a right angle, it will pass through the centre of the top of the cone.

36. A vessel in the form of an elliptic paraboloid, whose axis is vertical, and equation  $\frac{x^2}{a^2} + \frac{y^2}{b^2} = \frac{z}{h}$ , is divided into four equal compartments by its principal planes. Into one of these water is poured to the depth  $h$ ; prove that, if the resultant pressure on the curved portion be reduced to two forces, one vertical and the other horizontal, the line of action of the latter will pass through the point  $(\frac{2}{3}a, \frac{2}{3}b, \frac{1}{3}h)$ .

37. A bowl in the form of a hemisphere is filled with water; find the direction and magnitude of the resultant pressure on the upper portion of the bowl cut off by a plane through its centre inclined at a given angle to the horizon.

38. An open conical shell, the weight of which may be neglected, is filled with water, and is then suspended from a point in the rim, and allowed gradually to take its position of equilibrium; prove that, if the vertical angle be  $\cos^{-1} \frac{2}{3}$ , the surface of the water will divide the generating line through the point of suspension in the ratio 2 : 1.

39. A regular polygon wholly immersed in a liquid is moveable about its centre of gravity; prove that the locus of the centre of pressure is a sphere.

40. A hemispherical bowl is filled with water, and two vertical planes are drawn through its central radius, cutting off a semi-lune of the surface; if  $2a$  be the angle between the planes, prove that the angle which the resultant pressure on the surface makes with the vertical

$$= \tan^{-1} \left( \frac{\sin a}{a} \right).$$

41. A volume  $\frac{4\pi a^3}{3}$  of fluid of density  $\rho$  surrounds a fixed sphere of radius  $b$  and is attracted to a point at a distance  $c$  ( $< b$ ) from its centre by a force  $\mu r$  per unit mass; supposing the external pressure zero, find the resultant pressure on the fixed sphere.

42. A vessel in the form of a surface of revolution has the following property; if it be placed with its axis vertical, and any quantity of water be poured into it, the resultant vertical pressure has a constant ratio to the resultant horizontal pressure on either of the portions into which the surface is divided by a vertical plane through its axis; find the form of the surface.

43. Find the equation of a curve symmetrical about a vertical axis, such that, when it is immersed with its highest point at half the depth of its lowest, the centre of pressure may bisect the axis.

44. A rectangular area is immersed in compressible liquid with its plane vertical and one side in the surface, where the pressure is zero. Shew that, if

the density is a linear function of the pressure, the depth of the centre of pressure is

$$\frac{\alpha}{m} \frac{(m-1)\rho_1 + (1 - \frac{1}{2}m^2)\rho_0}{\rho_1 - (m+1)\rho_0},$$

where  $\alpha$  is the length of the vertical side,  $\rho_0, \rho_1$  are the densities at the top and bottom of the area, and

$$m = \log(\rho_1/\rho_0).$$

45. The vertices  $A, B, C$  of a triangular lamina are sunk in a homogeneous liquid to depths  $h_1, h_2, h_3$  respectively: prove that if  $p_1, p_2, p_3$  be the respective perpendiculars from  $A, B, C$  on  $BC, CA, AB$ , then the trilinear co-ordinates of the centre of pressure are

$$\frac{p_1}{4} \left( 1 + \frac{h_1}{h_1 + h_2 + h_3} \right), \quad \frac{p_2}{4} \left( 1 + \frac{h_2}{h_1 + h_2 + h_3} \right), \quad \frac{p_3}{4} \left( 1 + \frac{h_3}{h_1 + h_2 + h_3} \right).$$

46. A triangular lamina is totally immersed in a homogeneous liquid, the depths of the angular points being  $p, q, r$ ; prove that if the centre of pressure of the triangle coincide with the mean centre of its angular points for multiples  $l, m, n$ , then

$$p : q : r :: 3l - (m + n) : 3m - (n + l) : 3n - (l + m).$$

47. A cubical box of side  $a$  has a heavy lid of weight  $W$  moveable about one edge. It is filled with water, and held with the diagonal through one extremity of this edge vertical. If it be now made to rotate with uniform angular velocity  $\omega$ , shew that, in order that no water may be spilled,  $W$  must not be less than

$$\left( \frac{7}{6} + \frac{1}{2\sqrt{3}} \frac{\omega^2 a}{g} \right) W',$$

if  $W'$  is the weight of the water in the box.

48. A closed rigid vessel is formed by half the surface of an ellipsoid cut off by any central section, and by the plane section itself. The vessel is just full of water and stands with its plane base on a horizontal table. Prove that the resultant pressure on the curved surface is a vertical force equal to half the weight of the water, such that its line of action cuts the plane base at a distance  $\frac{2}{3}\sqrt{(r^2 - \varpi^2)}$  from the centre; where  $r$  is the semi-diameter conjugate to the base, and  $\varpi$  the perpendicular from the centre on the horizontal tangent plane.

49. A small solid body is held at rest in a fluid in which the pressure  $p$  at any point is a given function of the rectangular co-ordinates  $x, y, z$ ; prove that the components of the couple which tends to make it rotate round the centre of gravity of its volume are

$$(C - B) \frac{d^2 p}{dy dz} - D \left( \frac{d^2 p}{dy^2} - \frac{d^2 p}{dz^2} \right) - E \frac{d^2 p}{dy dx} + F \frac{d^2 p}{dz dx},$$

and two similar expressions, where  $A, B, C, D, E, F$  are the moments and products of inertia of the volume of the solid with respect to axes through the centre of gravity.

50. A rigid spherical shell of radius  $a$  contains a mass  $M$  of gas in which the pressure is  $\kappa$  times the density, and the gas is repelled from a fixed external point  $O$  (distant  $c$  from the centre) with a force per unit of mass equal to  $\kappa/(distance)$ . Prove that the resultant pressure of the gas on the shell is

$$\frac{\kappa M}{c} \frac{5c^2 - a^2}{5c^2 + a^2}.$$

51. A vessel full of water is in the form of an eighth part of an ellipsoid axes  $a, b, c$ ), bounded by the three principal planes. The axis  $c$  is vertical,

and the atmospheric pressure is neglected. Prove that the resultant fluid pressure on the curved surface is a force of intensity

$$\frac{1}{2} g \rho \{b^2 c^4 + a^2 c^4 + \frac{1}{2} \pi^2 a^2 b^2 c^2\}^{\frac{1}{2}}.$$

52. A hollow ellipsoid is filled with water and placed with its  $a$ -axis making an angle  $a$  with the horizontal and its  $c$ -axis horizontal. Prove that the fluid pressure on the curved surface on either side of the vertical plane through the  $a$ -axis is equivalent to a wrench of pitch

$$\frac{3c \sin a \cos a}{2} \cdot \frac{a^2 - b^2}{4c^2 + 9(\overline{a^2 \sin^2 a} + \overline{b^2 \cos^2 a})}.$$

53. The angular points of a triangle immersed in a liquid whose density varies as the depth are at distances  $\alpha, \beta, \gamma$  respectively below the surface, shew that the centre of pressure is at a depth

$$\frac{3}{5} \frac{(a + \beta + \gamma)(\overline{a^2 + \beta^2 + \gamma^2}) + a\beta\gamma}{a^2 + \beta^2 + \gamma^2 + a\beta + \beta\gamma + \gamma a}.$$

54. A plane area, completely submerged in a heavy heterogeneous fluid, rotates about a fixed horizontal axis at depth  $h$  perpendicular to its plane. If the density of the fluid at depth  $z$  be equal to  $\mu z$ , and if the area be symmetrical about each of two rectangular axes meeting at the point of intersection of the area with the axis of rotation, prove that the locus in space of the centre of pressure is an ellipse with its centre at a depth

$$2h - \frac{h(\overline{a^4 - k_1^2 k_2^2})}{(\overline{a^2 + k_1^2})(\overline{a^2 + k_2^2})},$$

where  $k_1$  and  $k_2$  are the radii of gyration of the area with respect to the axes of symmetry and the atmospheric pressure is

$$\frac{1}{2} g \mu (\overline{a^2} - h^2).$$

55. Shew that the pressure on any plane area immersed in water can be reduced to a force at the centroid of the area, and a couple about an axis in the plane of the area, and that the axis of this couple is perpendicular to the tangent at the end of the horizontal diameter of a momental ellipse at the centroid.

## CHAPTER IV

### THE EQUILIBRIUM OF FLOATING BODIES

48. *To find the conditions of equilibrium of a floating body.*

We shall suppose that the fluid is at rest under the action of gravity only, and that the body, under the action of the same force, is floating freely in the fluid. The only forces then which act on the body are its weight, and the pressure of the surrounding fluid, and in order that equilibrium may exist, the resultant fluid pressure must be equal to the weight of the body, and must act in a vertical direction.

Now we have shewn that the resultant pressure of a heavy fluid on the surface of a solid, either wholly or partially immersed, is equal to the weight of the fluid displaced, and acts in a vertical line through its centre of mass.

Hence it follows that the weight of the body must be equal to the weight of the fluid displaced, and that the centres of mass of the body, and of the fluid displaced, must lie in the same vertical line.

These conditions are necessary and sufficient conditions of equilibrium, whatever be the nature of the fluid in which the body is floating. If it be heterogeneous, the displaced fluid must be looked upon as following the same law of density as the surrounding fluid; in other words, it must consist of strata of the same kind as, and continuous with, the horizontal strata of uniform density, in which the particles of the surrounding fluid are necessarily arranged.

If for instance a solid body float in water, partially immersed, its weight will be equal to the weight of the water displaced, together with the weight of the air displaced; and if the air be removed, or its pressure diminished by a diminution of its density or temperature, the solid will sink in the water through a space depending upon its own weight, and upon the densities of air and water. This may be further explained by observing that the

pressure of the air on the water is greater than at any point above it, and that this surface pressure of the air is transmitted by the water to the immersed portion of the floating body, and consequently the upward pressure of the air upon it is greater than the downward pressure.

49. We now proceed to illustrate the application of the above conditions, by discussion of some particular cases.

Ex. 1. *A portion of a solid paraboloid, of given height, floats with its axis vertical and vertex downwards in a homogeneous liquid: required to find its position of equilibrium.*

Taking  $4a$  as the latus rectum of the generating parabola,  $h$  its height, and  $x$  the depth of its vertex, the volumes of the whole solid and of the portion immersed are respectively  $2\pi ah^2$  and  $2\pi ax^2$ ; and if  $\rho$ ,  $\sigma$  be the densities of the solid and liquid, one condition of equilibrium is

$$\rho \cdot 2\pi ah^2 = \sigma \cdot 2\pi ax^2;$$

$$\therefore x = \sqrt{\frac{\rho}{\sigma}} h,$$

which determines the portion immersed, the other condition being obviously satisfied.

Ex. 2. *It is required to find the positions of equilibrium of a square lamina floating with its plane vertical, in a liquid of double its own density.*

The conditions of equilibrium are clearly satisfied if the lamina float half immersed either with a diagonal vertical, or with two sides vertical.

To examine whether there is any other position of equilibrium, let the lamina be held with the line  $DGC$  in the surface, in which case the first condition is satisfied.

But, if the angle  $CGA = \theta$ , and if  $2a$  be the side of the square, the moment about  $G$  of the fluid pressure, which is the same as the difference between the moments of the rectangle  $AK$ , and of twice the triangle  $GBD$ , is proportional to

$$2a^2 \cdot \frac{a}{2} \sin \theta - a^2 \tan \theta \cdot \frac{a \sec \theta + a \cos \theta}{3},$$

or to

$$\sin \theta (1 - \tan^2 \theta),$$

and this vanishes only when  $\theta = 0$  or  $\frac{\pi}{4}$ .

Hence there is no other position of equilibrium.

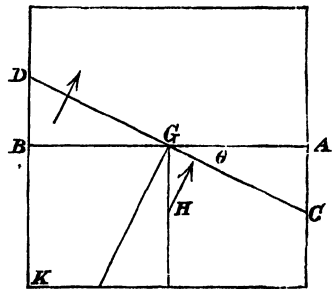

**Ex. 3.** *A triangular prism floats with its edges horizontal, to find its positions of equilibrium.*

Let the figure be a section of the prism by a vertical plane through its centre of gravity.

$PQ$  is the line of flotation and  $H$  the centre of gravity of the liquid displaced. When there is equilibrium the area  $APQ$  is to  $ABC$  in the ratio of the density of the prism to the density of the liquid, and therefore for all possible positions of  $PQ$  the area  $APQ$  is constant; hence  $PQ$  always touches, at its middle point, an hyperbola of which  $AB$ ,  $AC$  are the asymptotes.

Also  $HG$  must be perpendicular to  $PQ$ , and therefore since

$$AH : HE = AG : GF,$$

$FE$  must be perpendicular to  $PQ$ , that is,  $FE$  is the normal at  $E$  to the hyperbola. The problem is therefore reduced to that of drawing normals from  $F$  to the curve.

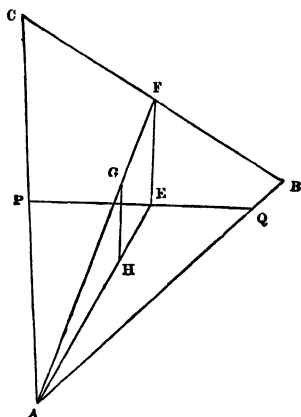

Let  $xy = c^2$  .....(a)

be the equation of the curve referred to  $AB$ ,  $AC$  as axes, and let

$$\angle BAC = \theta, \quad AB = 2a, \quad AC = 2b.$$

Let  $x, y$  be the co-ordinates of  $E$ ; the co-ordinates of  $F$  are  $a, b$ , and the equation of the normal at  $E$  is

$$\eta - y = \frac{y \cos \theta - x}{x \cos \theta - y} (\xi - x).$$

And if this pass through  $F$ , the co-ordinates of which are  $a, b$ ,

$$(b - y)(x \cos \theta - y) = (a - x)(y \cos \theta - x),$$

or  $x^2 - (a + b \cos \theta)x = y^2 - (a \cos \theta + b)y$  .....(b).

The equations (a) and (b) determine all the points of the hyperbola, the tangents at which can be lines of flotation.

Also (b) is the equation to an equilateral hyperbola, referred to conjugate diameters parallel to  $AB, AC$ ; the points of intersection of the two hyperbolas are therefore the positions of  $E$ .

To find  $x$ , we have

$$x^4 - (a + b \cos \theta) \cdot x^3 + (a \cos \theta + b) c^2 x - c^4 = 0,$$

an equation which has only one negative root, and one or three positive roots and there may be therefore three positions of equilibrium or only one.

If the densities of the liquid and the prism be  $\rho$  and  $\sigma$ , we have, since the area  $PAQ$

$$= \frac{1}{2} AP \cdot AQ \sin \theta = 2xy \sin \theta = 2c^2 \sin \theta,$$

$$2\rho c^2 \sin \theta = 2\sigma ab \sin \theta,$$

or  $\rho c^2 = \sigma ab,$

from which  $c$  is determined.

Suppose the prism to be isosceles, then putting  $a=b$ , the equation for  $x$  becomes

$$x^4 - c^4 - a(1 + \cos \theta)(x^3 - c^2x) = 0;$$

from which we obtain  $x=c$ , which gives  $y=c$ , and makes  $BC$  horizontal, an obvious position of equilibrium, and also

$$x = \frac{a}{2}(1 + \cos \theta) \pm \left\{ \frac{a^2}{4}(1 + \cos \theta)^2 - c^2 \right\}^{\frac{1}{2}} = a \cos^2 \frac{\theta}{2} \pm \left( a^2 \cos^4 \frac{\theta}{2} - c^2 \right)^{\frac{1}{2}};$$

the isosceles prism will therefore have only one position of equilibrium, unless

$$a \cos^2 \frac{\theta}{2} > c;$$

and, since  $\rho c^2 = \sigma a^2$ , this is equivalent to

$$\cos^2 \frac{\theta}{2} > \sqrt{\frac{\sigma}{\rho}}.$$

EX. 4. Determine the position of equilibrium of a balloon of given size and weight, neglecting the variations of temperature at different heights in the atmosphere.

If the temperature be constant, the pressure of the air at a height  $z = \Pi e^{-\frac{gz}{k}}$ , and its density  $= \frac{\Pi}{k} e^{-\frac{gz}{k}}$ ,  $\Pi$  being the atmospheric pressure at the level from which the height is measured.

The air displaced consists of a series of strata of variable density, and if  $z$  be the height of the lowest point of the balloon,  $x$  the distance from that point of any horizontal section ( $\lambda$ ) of the balloon, and  $h$  its height, the weight of a stratum of the air displaced is

$$\frac{\Pi g}{k} e^{-\frac{g(z+x)}{k}} \lambda \delta x,$$

and the whole weight of air displaced

$$= \int_0^h \frac{\Pi g}{k} e^{-\frac{g(z+x)}{k}} \lambda dx = \frac{\Pi g}{k} e^{-\frac{gz}{k}} \int_0^h e^{-\frac{gx}{k}} \lambda dx.$$

The form of the balloon being given,  $\lambda$  is a known function of  $x$ , and if  $W$  be the weight of the balloon and of the gas it contains, the height  $z$  will be determined by equating  $W$  to the expression we have obtained for the weight of the air displaced.

50. A homogeneous solid floats, wholly immersed, in a liquid of which the density varies as the depth; to find the depth of its centre of mass.

Let  $a, c$  be the depths of the highest and lowest points of the solid,  $Z$  the area of a horizontal section of the solid at a depth  $z$ , and  $\mu z$  the density;

$$\text{the weight of the liquid displaced} = \int_a^c g \mu z Z dz.$$

Let  $\bar{z}$  be the depth of the centroid of the volume of the solid, and  $V$  its volume, then

$$V\bar{z} = \int_a^c Zz dz;$$

therefore the weight of displaced liquid  $= g\mu\bar{z}V$ , and if  $\rho$  be the density of the solid, its weight  $= g\rho V$ ; hence  $\rho = \mu\bar{z}$ , or the solid floats in such a position that the density of the liquid at the depth of the centroid of the volume of the solid is equal to the density of the solid.

**51.** If a solid float under constraint, the conditions of equilibrium depend on the nature of the constraining circumstances, but in any case the resultant of the constraining forces must act in a vertical direction, since the other forces, the weight of the body, and the fluid pressure, are vertical.

If for instance one point of a solid be fixed, the condition of equilibrium is that the weight of the body and the weight of the fluid displaced should have equal moments about the fixed point; this condition being satisfied, the solid will be at rest, and the stress on the fixed point will be the difference of the two weights.

As an additional illustration, consider the case of a solid floating in water and supported by a string fastened to a point above the surface; in the position of equilibrium the string will be vertical, and the tension of the string, together with the resultant fluid pressure, which is equal to the weight of the displaced fluid, will counterbalance the weight of the body; the tension is therefore equal to the difference of the weights, and the weights are inversely in the ratio of the distances of their lines of action from the line of the string, these three lines being in the same vertical plane.

**52.** For subsequent investigations, the following geometrical propositions will be found important.

*If a solid be cut by a plane, and this plane be made to turn through a very small angle about a straight line in itself, the volume cut off will remain the same, provided the straight line pass through the centroid of the area of the plane section.*

To prove this, consider a right cylinder of any kind cut by a plane making with its base an angle  $\theta$ .

Let  $\bar{z}$  be the distance from the base of the centroid of the

section  $A$ ,  $\delta A$  an element of the area of the section and  $V$  the volume between the planes. Then

$$\bar{z} = \frac{\Sigma(\delta A \cdot PN)}{A};$$

$$\therefore A \cos \theta \bar{z} = \Sigma(\delta A \cos \theta \cdot PN) = V,$$

or

$$V = \bar{z} (\text{area of base}).$$

Now the centroid of the area  $A$  is also the centroid of all sections made by planes passing through it, as may be seen by projecting the sections on the base of the cylinder; it follows therefore, that  $\bar{z}$  being the same for all such sections, the volumes cut off are the same.

In the case of any solid, if the cutting plane be turned through a very small angle about the centroid of its section, the surface near the curves of section may be considered, without sensible error, cylindrical, and the above proposition is therefore established\*.

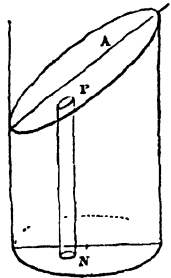

In other words, the difference between the volume lost and the volume gained by the change in the position of the cutting plane will be indefinitely small compared with either.

\* The following form of proof may also be given.

Let  $ACB$ , the cutting plane, be turned through a small angle ( $\theta$ ) about a line  $Cx$ , and let  $dA$  be an element of the area.

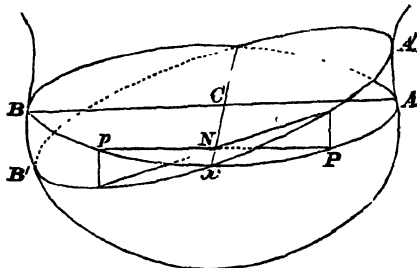

Then the algebraical value of the additional volume cut off is equal to  $\int \theta y dA$ , and, if this vanishes,  $\int y dA = 0$ , which is the condition that the centroid of  $A$  should lie in the axis of  $x$ ; and, taking  $C$  as the centroid, any plane through  $C$  will satisfy the same condition.

We may observe that the algebraical moment about the axis of  $y$  of the volume cut off is  $\int \theta x y dA$ , which vanishes if  $\int x y dA = 0$ , that is, if the axes  $Cx$ ,  $Cy$  be the principal axes of the area.

**53. Definitions.** If a body float in a homogeneous liquid, the plane in which the body is intersected by the surface of the liquid is the **plane of flotation**.

The point  $H$ , the centre of mass of the liquid displaced, is the **centre of buoyancy**.

If the body move so that the volume of liquid displaced remains unchanged, the envelope of the planes of flotation, is the **surface of flotation**, and the locus of  $H$  is the **surface of buoyancy**.

**54.** If a plane move so as to cut from a solid a constant volume, and if  $H$  be the centroid of the volume cut off, the tangent plane at  $H$  to the surface which is the locus of  $H$  is parallel to the cutting plane.

In other words, the tangent planes at any point of the surface

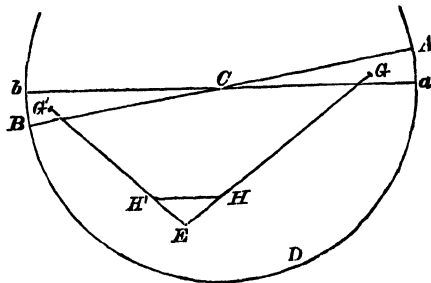

of flotation, and at the corresponding point of the surface of buoyancy, are parallel to one another.

Turn the plane  $ACB$ , the cutting plane, through a small angle into the position  $aCb$ , the volumes of the wedges  $ACa$ ,  $BCb$  being equal.

Let  $G$  and  $G'$  be the centroids of these wedges.

In  $GH$  produced take a point  $E$  such that

$$EH : HG :: \text{Volume } ACa : \text{Volume } aDB.$$

Join  $EG'$  and take  $H'$  such that

$$EH' : H'G' :: \text{Vol. } BCb : \text{Vol. } aDB;$$

then  $H'$  is the centroid of  $aDb$ ;

but  $EH : HG :: EH' : H'G'$ ,

and  $HH'$  is therefore parallel to  $GG'$ .

Hence it follows that ultimately when the angle  $ACa$  is indefinitely diminished,

$HH'$  is parallel to  $ACB$ ;

and  $HH'$  is a tangent at  $H$  to the locus of  $H$ .

This being true for any displacement of the plane  $ACB$  about its centroid, it follows that the tangent plane at  $H$  to the locus of  $H$  is parallel to the plane  $ACB$ .

✓ 55. *The positions of equilibrium of a body floating in a homogeneous liquid are determined by drawing normals from  $G$ , the centre of mass of the body, to the surface of buoyancy.*

For if  $GH$  be a normal to the surface of buoyancy, the tangent plane at  $H$ , being parallel to the plane of flotation, is horizontal, and  $GH$  is therefore vertical.

The two conditions of equilibrium are then satisfied, and a position of equilibrium is determined.

The problem comes to the same thing as determining the positions of equilibrium of a heavy body, bounded by the surface of buoyancy, on a horizontal plane.

56. It should be noticed that the shape of the curve of buoyancy is entirely determined by the form of the bounding surface, and is unaffected by an alteration of the form of that portion of the body which always remains immersed.

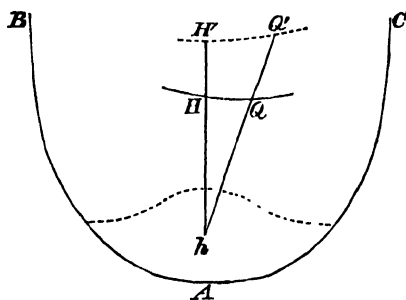

Let  $HQ$  be an arc of the surface of buoyancy for a boundary  $BAC$ , and an immersed volume  $V$ , and imagine a volume  $v$ , the centroid of which is  $h$ , to be cut off.

Taking  $hH' : hH :: hQ' : hQ :: V : V - v$ , the surface  $H'Q'$  is the new surface of buoyancy which is obviously similar to the surface  $HQ$ .

57. *Particular cases of curves of buoyancy.*

For a triangular prism, as in Art. (49), the curve of flotation is the envelope of  $PQ$ , which is an hyperbola having  $AB, AC$  for asymptotes; and, since  $AH = \frac{2}{3}AE$ , the curve of buoyancy is a similar hyperbola.

If the body be a plane lamina bounded by a parabola, the curves of flotation and buoyancy are equal parabolas.

If the boundary be an elliptic arc, the curves are arcs of similar and similarly situated concentric ellipses.

If the immersed portion of a lamina (or prism) be a rectangle, the curve of flotation apparently is a single point, and the curve of buoyancy is a parabola.

To prove this, let  $H, H'$  be positions of the centroid corresponding to the positions  $ACB, A'CB'$  of the line of flotation.

Then, if  $AC = CB = a, BB' = \beta, CH = c$ , and  $S =$  the area cut off,

$$Sy = S. H'N = \frac{1}{2}a\beta \cdot \frac{2a}{3} - \frac{1}{2}a\beta \left(-\frac{2a}{3}\right) = \frac{2}{3}a^2\beta,$$

$$Sx = S. HN = \frac{1}{2}a\beta \left(c + \frac{\beta}{3}\right) - \frac{1}{2}a\beta \left(c - \frac{\beta}{3}\right) = \frac{1}{3}a\beta^2,$$

and  $\therefore Sy^2 = \frac{4}{3}a^2x.$

This is a particular case of the triangular prism, and, as in that case, the curves of flotation and buoyancy are similar curves, the fact being that the curve of flotation is a parabola, with its vertex at  $C$ , flattened down to a straight line.

In the case of Ex. (2), Art. (49),  $S = 2a^2$ , and the curve of buoyancy is the parabola,  $3y^2 = 2ax$ .

The radius of curvature at the vertex,  $H$ , of this parabola is  $\frac{1}{3}a$ , which is less than  $HG$ .

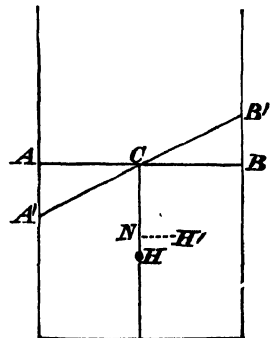

Hence it will be seen that three normals can be drawn to the curve of buoyancy, giving the three positions of equilibrium.

**58.** If the body be a lamina bounded by an hyperbolic arc, the curves are similar hyperbolas.

Thus, if  $QVQ'$  be a line of flotation, and if  $2a', 2b'$  be the diameters conjugate and parallel to  $QQ'$ , inclined at an angle  $\theta$ , so that  $a'b' \sin \theta = ab$ ,

the area  $QPQ' = 2 \int_{a'}^{x'} \frac{b'}{a'} \sqrt{x^2 - a'^2} \sin \theta dx$

$$= ab \left\{ \frac{x'}{a'} \sqrt{\frac{x'^2}{a'^2} - 1} - \log \left( \frac{x'}{a'} + \sqrt{\frac{x'^2}{a'^2} - 1} \right) \right\},$$

so that the ratio of  $x'$  to  $a'$ , that is, of  $CV$  to  $CP$ , is constant.

Moreover,

$$\begin{aligned} (\text{area}) (CH) &= 2 \frac{b'}{a'} \sin \theta \int_{a'}^{x'} x \sqrt{x^2 - a'^2} dx \\ &= \frac{2}{3} ab \left( \frac{x'^2}{a'^2} - 1 \right)^{\frac{3}{2}} a'; \end{aligned}$$

and therefore the ratio of  $CH$  to  $CP$  is constant.

These results can also be obtained by purely geometrical reasoning.

**59.** In the case of a right circular cone floating with its vertex beneath the surface, the surfaces of flotation and buoyancy are hyperboloids of revolution.

If  $V$  is the vertex of the cone,  $ACB$  the major axis of a section, and  $VK$  the perpendicular upon  $AB$ , the volume  $VAB$  is equal to

$$\frac{1}{3} VK \cdot \frac{1}{2} \pi AB \cdot \{AV \cdot BV \sin^2 \alpha\}^{\frac{1}{2}}.$$

But

$$VK \cdot AB = VA \cdot VB \sin 2\alpha,$$

each expression being double the area  $VAB$ ; therefore, the volume being constant, it follows that the area  $VAB$  is constant.

The locus of  $C'$ , the centroid of the plane section, is therefore a hyperboloid of revolution, and,  $VH$  being three-fourths of  $VC$ , the surface of buoyancy is a similar hyperboloid.

**60. Surfaces of buoyancy and flotation for an ellipsoid.**

If the ellipsoid have equation  $x^2/a^2 + y^2/b^2 + z^2/c^2 = 1$ , the substitutions  $x = a\xi, y = b\eta, z = c\zeta$  reduce the problem to that of the

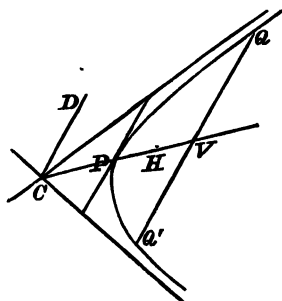

sphere  $\xi^2 + \eta^2 + \zeta^2 = 1$ ; and if  $V$  denote the immersed volume of the ellipsoid,  $V/abc$  denotes the corresponding volume of the sphere. It is clear that the plane which cuts off this volume touches a concentric sphere of radius  $r$ , such that

$$\int_r^1 \pi (1 - x^2) dx = V/abc,$$

or  $\frac{1}{3} \pi (1 - r)^2 (2 + r) = V/abc.$

Also the centroid of the volume cut off lies on a sphere of radius  $R$ , where

$$R \int_r^1 \pi (1 - x^2) dx = \int_r^1 \pi x (1 - x^2) dx$$

or  $R = \frac{3}{4} (1 + r)^2 / (2 + r).$

Returning to the original problem we see that the surface of flotation is a similar ellipsoid of semi-axes  $ra, rb, rc$ , where

$$(1 - r)^2 (2 + r) = 3V/\pi abc \dots\dots\dots(1);$$

and the surface of buoyancy is another similar ellipsoid of semi-axes  $Ra, Rb, Rc$ , where

$$R = \frac{3}{4} (1 + r)^2 / (2 + r) \dots\dots\dots(2).$$

Similar results hold good for a hyperboloid of two sheets.

**Art. 61. Elliptic Paraboloid.**

This case can be deduced from the results for an ellipsoid by making  $a, b, c$  tend to infinity in such a way that  $a^2/c \rightarrow \alpha$  and  $b^2/c \rightarrow \beta$ , where  $\alpha, \beta$  are the semi latera recta of the principal sections of the paraboloid. If, as before,  $V$  denotes the finite volume immersed, then  $V/abc$  tends to zero, so that  $r$  and also  $R$  both tend to unity. Hence the surfaces of flotation and buoyancy are equal paraboloids. Also the distances between their vertices and the vertex of the given paraboloid are the limiting values of  $c(1 - r)$  and  $c(1 - R)$ .

But, from Art. 60 (1), we see that

$$\frac{1}{2} c^2 (1 - r)^2 = \frac{3Vc}{(2 + r)\pi ab} \rightarrow \frac{V}{\pi \sqrt{\alpha\beta}};$$

so that the intercept on the axis between the given paraboloid and the surface of flotation is  $\gamma$ , where

$$\gamma^2 = V/\pi \sqrt{\alpha\beta}.$$

Similarly, from Art. 60 (2),

$$c(1 - R) = \frac{c(1 - r)(5 + 3r)}{4(2 + r)} \rightarrow \frac{3}{4} \gamma,$$

thus determining the corresponding intercept for the surface of buoyancy.

### 62. Cylinder of any section.

The surface of flotation is a point on the line of centroids  $Oz$ , given by  $Az = \bar{V}$ , where  $A$  is the cross section and  $V$  the volume immersed.

Let  $z = lx + my + c$  be the equation of the cutting plane, the origin being in the base.

The coordinates  $(\bar{x}, \bar{y}, \bar{z})$  of the centre of buoyancy are given by

$$\begin{aligned} V\bar{x} &= \iint xz \, dx \, dy \text{ integrated over the base} \\ &= \iint x(c + lx + my) \, dx \, dy \\ &= al + hm. \end{aligned}$$

Similarly

$$\begin{aligned} Vy &= \iint yz \, dx \, dy \\ &= hl + bm; \end{aligned}$$

and

$$\begin{aligned} V\bar{z} &= \frac{1}{2} \iint z^2 \, dx \, dy \\ &= \frac{1}{2} (al^2 + 2hlm + bm^2) + \frac{1}{2} c^2 A; \end{aligned}$$

where  $a = \iint x^2 \, dx \, dy$ ,  $h = \iint xy \, dx \, dy$ ,  $b = \iint y^2 \, dx \, dy$ .

If we use the principal axes of the section as axes of  $x$  and  $y$ , we have  $h = 0$ , and

$$V\bar{x} = al, \quad Vy = bm, \quad V(z - \frac{1}{2}c) = \frac{1}{2}(al^2 + bm^2).$$

Therefore the equation of the surface of buoyancy is

$$\frac{x^2}{a} + \frac{y^2}{b} = \frac{2z - c}{V}.$$

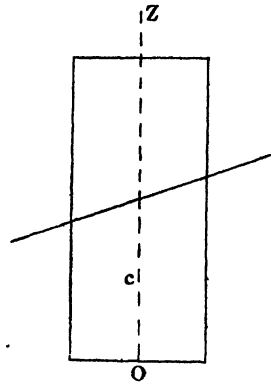

**63.** *A solid of revolution floats in a liquid which rotates uniformly, as if solid, about a vertical axis, the axis of the solid coinciding with the axis of rotation; required to find the condition of equilibrium.*

In a mass of rotating liquid, suppose a surface of revolution described, having its axis coincident with the axis of rotation, and consider the equilibrium of the liquid within this surface. The resultant of the fluid pressures upon the liquid must be equal to its weight, and the same pressures being exerted on the surface of any solid occupying the same space, it follows that any such solid

will be in equilibrium, if its weight be equal to the weight of the fluid it displaces.

It will be seen moreover that it is quite indifferent whether the solid rotate with the fluid, or with a different angular velocity, or be at rest.

*Ex. A cylinder floats in rotating liquid; to find the depth to which it is immersed.*

If  $\omega$  be the angular velocity, the equation to the generating parabola of the free surface, taking its vertex as the origin, is  $\omega^2 y^2 = 2gz$ , and if  $z'$  be the depth of the base of the cylinder below the circle of flotation, that is, the circle in which the free surface intersects the surface of the cylinder, and  $c$  the radius of the cylinder, the volume of the displaced fluid is the difference between the volume of a height  $z'$  of the cylinder, and the volume of a height  $\frac{\omega^2 c^2}{2g}$  of the paraboloid.

Hence, if  $\sigma$  be the density of the cylinder and  $\rho$  of the fluid,

$$\sigma \pi c^2 h = \rho \left( \pi c^2 z' - \frac{\pi \omega^2 c^4}{4g} \right),$$

and 
$$z' = \frac{\sigma}{\rho} h + \frac{\omega^2 c^2}{4g}.$$

**64.** A more general case is that of a body floating, wholly or partially immersed, in a liquid at rest under the action of any given forces, the same forces being supposed to act on the molecules of the body.

If the body be in equilibrium, the resulting force upon it will be equal to the resulting force on the liquid displaced, and the lines of action of the two forces will be the same.

For, if the body be removed, and its place occupied by the displaced liquid, the resulting pressure of the liquid upon the body will be the same as upon the displaced liquid, and will therefore be equal and opposite to the resultant force upon the displaced liquid.

*Ex. A mass of liquid is at rest under the action of a force to a fixed point varying as the distance, and a solid in the form of a spherical sector is at rest partly immersed in it, with its vertex at the fixed point; it is required to compare the densities of the liquid and the solid.*

In the state of equilibrium, let  $r$  be the radius of the free surface of the liquid, and  $a$  the radius of the spherical sector. The volumes of the sector and of the displaced liquid are in the ratio of  $a^3$  to  $r^3$ ; and the distances of their centres of mass from the centre of force are in the ratio of  $a$  to  $r$ ;

$$\therefore \text{if } \rho \text{ and } \sigma \text{ be the densities, } \rho a^4 = \sigma r^4.$$

## EXAMPLES

1. A solid formed of two co-axial right cones, of the same vertical angle, connected at the vertices, is placed with one end in contact with the horizontal base of a vessel: water is then poured into the vessel; shew that if the altitude of the upper cone be treble that of the lower, and the common density of the spindle four-sevenths that of the water, it will be upon the point of rising when the water reaches to the level of its upper end.

2. A cone, of given weight and volume, floats with its vertex downwards; prove that the surface of the cone in contact with the liquid is least when its vertical angle is  $2 \tan^{-1} \frac{1}{\sqrt{2}}$ .

3. A square board is placed in liquid of four times its density; shew that there are three different positions in which it will float with one given corner only below the surface of the fluid.

4. A body is floating in water; a hollow vessel is inverted over it and depressed: what effect will be produced in the position of the body, (1) with reference to the surface of the water within the vessel, (2) with reference to the surface of the fluid outside?

5. A hollow hemispherical shell has a heavy particle fixed to its rim, and floats in water with the particle just above the surface, and with the plane of the rim inclined at an angle of  $45^\circ$  to the surface; shew that the weight of the hemisphere: the weight of the water which it would contain

$$:: 4\sqrt{2} - 5 : 6\sqrt{2}.$$

6. A cone of semi-vertical angle  $30^\circ$  and axis  $h$  floats with its axis vertical and vertex downwards in a fluid whose density is one-third greater than its own; shew that the rim of its base will be just immersed if the fluid rotate, as if rigid, with angular velocity  $\sqrt{g/\sqrt{h}}$  about a vertical line coinciding with the axis of the cone.

7. A solid cone is divided into two parts by a plane through its axis, and the parts are connected by a hinge at the vertex; the system being placed in water with its axis vertical and vertex downwards, shew that, if it float without separation of the parts, the length of the axis immersed is greater than  $h \sin^2 a$ ,  $h$  being the height of the cone, and  $2a$  its vertical angle.

8. A cone, the vertex of which is fixed at the bottom of a vessel containing water, is in equilibrium, with its slant side vertical and the lowest point of its base just touching the surface. Compare the density of the cone with that of the water.

9. The curved surface of a cup is formed by the revolution of a portion of the curve  $\frac{x}{a} = \log \frac{y}{b}$  about its asymptote. It floats in liquid with its axis vertical and narrow end downwards, and a heavier liquid is poured into it. Shew that if the cup be made of proper weight, the distance between the surfaces of the two liquids will be constant.

10. A cylinder floats in a liquid with its axis inclined at an angle  $\tan^{-1} 2/5$  to the vertical, and its upper end just above the surface; prove that the radius is  $4/7$  of the height of the cylinder.

11. Two rods of the same substance have their ends fastened together, and float in a liquid with the angle immersed; shew that the curve of buoyancy is a parabola.

12. A cone floats, with vertex downwards, in a cylindrical basin of water, and is lifted just out of the water (without tilting); shew that the work done is

$$W \left( \frac{2}{3}l - \frac{1}{2}l' \right),$$

where  $W$  is the weight of the cone,  $l$  is the depth of the vertex below the surface in equilibrium,  $l'$  is the length of the cylinder which would be filled by the water then displaced by the cone.

13. Find the surfaces of flotation and of buoyancy in the case of a right circular cylinder floating with one end immersed.

14. If a given quantity of homogeneous matter be formed into a paraboloid of revolution and allowed to float with the vertex downwards, the square of the distance of the centre of gravity from the plane of flotation will be inversely proportional to the latus rectum.

15. A hollow hemispherical cup is closed by a lid of the same small thickness and of the same substance: shew that, if it float in a liquid with its centre in the surface, the inclination of the lid to the vertical will be  $\pi/8$ .

16. A right circular cone has a plane base in the form of an ellipse; the cone floats with its longest generating line horizontal; if  $2a$  be the vertical angle, and  $\beta$  the angle between the plane base and the shortest generating line, shew that

$$5 \cot \beta = 5 \cot 4a - \operatorname{cosec} 4a.$$

✓ 17. If the height of a right circular cone be equal to the diameter of the base, it will float, with its slant side horizontal, in any liquid of greater density.

✓ 18. A cone, whose height is  $h$  and vertical angle  $2a$ , has its vertex fixed at distance  $c$  beneath the surface of a liquid; shew that it will rest with its base just out of the liquid if

$$\sigma c^4 \cos^3 a \cos \theta = \rho h^4 [\cos(\theta - a) \cos(\theta + a)]^{\frac{5}{2}},$$

where  $\sigma$  and  $\rho$  are the densities of the liquid and cone, and  $\theta$  is given by the equation  $c \cos a = h \cos(\theta + a)$ .

19. A tetrahedron floats in water with one corner immersed. The three edges which meet in this corner are equal and mutually at right angles. Shew that there are one, two, or three distinct positions of equilibrium, according as the ratio of the density of the tetrahedron to that of the water is greater, equal to, or less than 4 : 27.

✓ 20. A hemispherical shell (radius  $2a$ ) containing water rotates with an angular velocity  $\sqrt{3g}/\sqrt{7a}$  about its axis which is vertical: a sphere (radius  $a$ ) rests on the water with its lowest point in contact with the shell without pressure on it. If the free surface passes through the rim of the shell, shew that

$$\text{density of sphere : density of water} :: 128 : 189.$$

21. An isosceles triangular lamina  $ABC$ , right-angled at  $C$ , floats, with its plane vertical and the angle  $C$  immersed, in a liquid of which the density varies as the depth; prove that, if  $\pi/4 + \theta$  be the angle which  $AB$  makes with the vertical, in either of the positions of equilibrium in which  $AB$  is not horizontal, the value of  $\theta$  is given by an equation of the form

$$m \sin^2 \theta \cos^2 \theta = (\sin \theta + \cos \theta)^3.$$

✓ 22. A right circular cylinder, whose axis is vertical, contains a quantity of liquid, the density of which varies as the depth, and a right cone whose axis is coincident with that of the cylinder and which is of equal base, is allowed to sink slowly into the liquid with its vertex downwards. If the cone be in equilibrium when just immersed, prove that the density of the cone is equal

to the initial density of the liquid at a depth equal to  $\frac{1}{15}$ th the length of the axis of the cone.

23. A solid cone, of height  $h$ , vertical angle  $2a$ , and density  $\rho$ , is moveable about its vertex, and its vertex is fixed at a depth  $c$  below the surface of a liquid, the density of which, at a depth  $z$ , is  $\mu z$ . The cone is in equilibrium with its axis inclined at an angle  $\theta$  to the vertical, and its base above the surface; prove that

$$\mu c^5 \cos^3 a \cos \theta = 5\rho h^4 \{\cos(\theta + a) \cos(\theta - a)\}^{\frac{5}{2}}.$$

24. A hollow paraboloidal vessel floats in water with a heavy sphere lying in it. There being an opening at the vertex, the water occupies the whole of the space between the vessel and the sphere. If the resultant pressure on the sphere be equal to half the weight of the water which would fill it, shew that the depth of the centre of the sphere below the surface of the water is  $4a^2/3c$ , where  $4a$  is the latus rectum of the paraboloid, and  $c$  the distance of the plane of contact from the vertex.

25. A right cone floats with its vertex downwards in a fluid of which the density varies as the depth. Shew that if its axis can make an angle  $\theta$  with the vertical in a position of equilibrium, then

$$5 \cos a \sec \theta (\cos^2 \theta - \sin^2 a)^{\frac{5}{2}} = 4 \sqrt[4]{4\sigma/\rho},$$

where  $a$  is the semi-vertical angle of the cone,  $\sigma$  its density,  $\rho$  that of the fluid at a depth equal to the slant side of the cone.

26. A right-angled triangular prism floats in a fluid of which the density varies as the depth with the right angle immersed and the edges horizontal; shew that the curve of buoyancy is of the form

$$r^6 \sin^4 \theta \cos^4 \theta = c^6.$$

27. A life-belt in the form of an anchor-ring generated by a circle of radius  $a$  floats in water with its equatorial plane horizontal; shew that  $z$ , the depth immersed, is given by the equations

$$\begin{aligned} z &= a(1 - \cos \beta), \\ 2\pi s &= (2\beta - \sin 2\beta); \end{aligned}$$

where  $s$  is the specific gravity of the material of the belt.

28. A parabolic lamina, bounded by a double ordinate perpendicular to the axis, floats vertex downwards in a liquid with its focus in the surface and its axis inclined at the angle  $\tan^{-1} \sqrt{7/2}$  to the vertical; prove that the density of the liquid is to that of the lamina as  $216 : 11^{\frac{1}{2}}$ , and that the length of the bounding ordinate is three times the latus rectum.

29. A solid cone of density  $\sigma$ , height  $h$ , and vertical angle  $2a$  can turn freely about its vertex which is fixed at a height  $d$  above the surface of a liquid of density  $\rho$ . If it float with its base wholly immersed, and its axis inclined obliquely at an angle  $\theta$  with the vertical, shew that

$$h^4 (\rho - \sigma) \{\cos(\theta + a) \cos(\theta - a)\}^{\frac{5}{2}} = d^4 \rho \cos \theta \cos^3 a.$$

30. An indefinitely small piece of ice, the shape of which may be taken to be that of a right circular cylinder, is floating in water with its axis vertical. The part immersed receives deposits of ice in such a manner as to continue cylindrical, the radius and axis receiving equal increments in equal times. Find the ultimate shape of the part not immersed.

If the specific gravity of ice be .96, prove that the surface is formed by the revolution of the curve

$$y^2(9x - y)^{26} = a^{27}.$$

31. Describe the complete surface of buoyancy for an equilateral triangle floating in a liquid of four times its density, and shew that at points where the curvature is discontinuous the tangents to the curve intersect at an angle

$$\tan^{-1} \frac{12\sqrt{3}}{107}.$$

32. A solid bounded by the planes  $x = \pm a$ ,  $y = \pm b$ ,  $z = 0$  and  $z = c$  floats in water with the base  $z = 0$  wholly immersed. Shew that for displacements such that the volume  $V$  immersed remains constant and the base is entirely under water and the opposite face entirely out of the water, the equation of the surface of buoyancy is

$$\frac{x^2}{a^2} + \frac{y^2}{b^2} = \frac{8abc}{3V} - \frac{1}{3}.$$

33. A cylindrical vessel with its cross-section of any shape floats with a length  $2c$  of its axis immersed when the axis is vertical. Prove that the equation of the surface of buoyancy is  $x^2/a^2 + y^2/b^2 = z/c$ ; where the origin is taken at the middle point of the portion of the axis immersed for the upright position, the axis of  $z$  is vertically upwards, and the axes of  $x$ ,  $y$  parallel to the principal axes of moments of inertia of the plane of flotation for the upright position through its centre of gravity, and  $b$ ,  $a$  are the radii of gyration for those axes of the plane of flotation.

## THE STABILITY OF THE EQUILIBRIUM OF FLOATING BODIES

**65.** If a floating body be slightly displaced, it will in general either tend to return to its original position, or will recede farther from that position; in the former case the equilibrium is said to be *stable*, and in the latter *unstable*, for that particular direction of displacement.

Consider first a small vertical displacement: it is clear that, if the body be floating partially immersed in homogenous fluid, or if it be immersed, either wholly or partially, in a heterogeneous fluid of which the density increases with the depth, a depression will increase the weight of the fluid displaced, and on the contrary an elevation will diminish it; in either case the tendency of the fluid pressure is to restore the body to its position of rest, and the equilibrium is stable with regard to vertical displacements. This, it will be observed, is only shewn to be true of rigid bodies; if the increased pressure, caused by depression, have the effect of compressing any portion of the floating body, the equilibrium is not necessarily stable, and in fact it may be unstable.

An arbitrary displacement will in general involve both vertical and angular changes in the position of the body; if however the displacement be small, as we have supposed to be the case, the effects of the two changes of position can be treated independently; and we proceed to consider the effect of a small angular displacement, on the supposition that the weight of fluid displaced remains unchanged, and consequently that the fluid pressure has no tendency to raise or depress the centre of mass of the body.

**66.** *A solid, floating at rest in a homogeneous liquid, is made to turn through a very small angle in a given vertical plane; to*

determine whether the fluid pressure will tend to restore it to its original position or not.

Suppose that the body is turned through a small angle  $\theta$  about an axis  $Oy$  in the plane of flotation  $AOB$ ;  $Oy$  being at right angles to the plane of the paper,  $Ox$  in the plane of flotation and  $Oz$  vertical in the original position; and as the body is turned let the axes be carried with it.

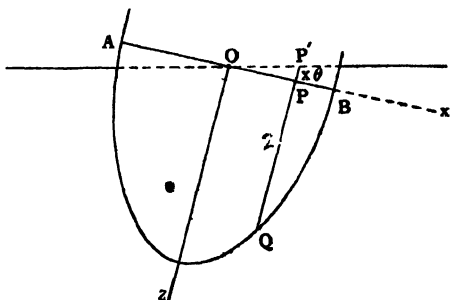

If  $dxdy$  denotes an element of area on the plane of flotation  $AOB$ , the volume of an elementary column  $PQ$  is  $zdxdy$  where  $z$  denotes the length  $PQ$ . In the displaced position the length of the corresponding column  $P'Q$  is  $z + x\theta$  and its volume is  $(z + x\theta)dxdy$ . Hence the volume  $V$  of liquid displaced will be the same in both cases if

$$\iint (z + x\theta) dxdy = V = \iint zdxdy$$

where the integrations are over the section of the body made by the plane of flotation in the original position.

This reduces to  $\iint x dxdy = 0$ , which means that the centre of gravity of the surface section must lie on  $Oy$ , as was proved in Art. 52.

Assume that this condition is satisfied. In the original position the centre of gravity  $G$  and centre of buoyancy  $H$  are in the same vertical and we may denote the co-ordinates of the latter by  $(\bar{x}, \bar{y}, \bar{z})$  and note that  $G$  will have the same  $(\bar{x}, \bar{y})$ . In the displaced position there is a new centre of buoyancy  $H'$  whose co-ordinates referred to the original axes are  $(\bar{x}', \bar{y}', \bar{z}')$ .

$$\text{Now } V\bar{x} = \iint xz dxdy, \quad V\bar{y} = \iint yz dxdy, \quad V\bar{z} = \iint \frac{1}{2}z^2 dxdy.$$

These integrals being written down by taking the elementary column  $PQ$  of volume  $zdxdy$  with its centre of gravity at the middle point of its length.

In the displaced position the corresponding elementary column is  $P'Q'$  of length  $z + x\theta$ ; its centre of gravity is at a distance

$\frac{1}{2}(z + x\theta)$  from  $P'$ , and therefore at a distance  $\frac{1}{2}(z - x\theta)$  from  $P$ , so that we have

$$V\bar{x}' = \iint x(z + x\theta) dx dy, \quad Vy' = \iint y(z + x\theta) dx dy,$$

$$V\bar{z}' = \iint \frac{1}{2}(z - x\theta)(z + x\theta) dx dy.$$

We observe that, to the first power of the small angle  $\theta$ , we have  $\bar{z}' = \bar{z}$ , so that the tangent plane to the surface of buoyancy is parallel to the plane of flotation, as was proved in Art. 54.

Now in the displaced position the body is subject to two equal and opposite parallel forces, viz. its weight  $W$  or  $g\rho V$  vertically downwards through  $G$  and the force of buoyancy vertically upwards through  $H'$ . These forces form a couple and the plane of this couple will be at right angles to the axis of rotation if, and only if, the points  $G, H'$  are in a vertical plane perpendicular to  $Oy$ , i.e. if  $y' = \bar{y}$ ,

or 
$$\iint y(z + x\theta) dx dy = \iint yz dx dy.$$

This reduces to 
$$\iint xy dx dy = 0,$$

which means that the axis of rotation  $Oy$  must be a principal axis of inertia of the section of the body made by the plane of flotation.

When this condition is satisfied the vertical through  $H'$  intersects the line  $HG$  in a point  $M$  called the **meta-centre**. The couple acting on the body is  $W \cdot GM \theta$  and it tends to restore the body to its former position or to increase the displacement according as  $M$  is above or below  $G$ .

Also, we have  $HM \cdot \theta = HH' = \bar{x}' - \bar{x}$

$$= \frac{\theta \iint x^2 dx dy}{V}.$$

Therefore  $HM = Ak^2/V$ , where  $Ak^2$  denotes the moment of inertia of the section of the body made by the plane of flotation about the axis of rotation.

The couple tending to restore the body is therefore

$$g\rho V(HM - HG) = g\rho(Ak^2 - V \cdot HG) \cdot \theta$$

67. Since there are two principal axes through the centre of gravity of the surface section of the body with corresponding

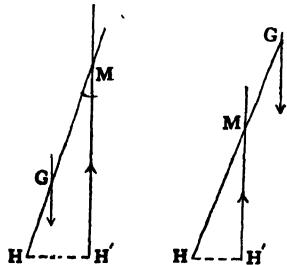

moments of inertia  $I_1$  and  $I_2$ , it follows that a displacement about either of these axes would set up a couple in the plane of the displacement tending to restore equilibrium if  $HG < I_1/V$  and also  $< I_2/V$ . Hence these conditions are necessary for stability of equilibrium.

**68. Work done in producing a displacement.** When the body has been displaced through a small angle  $\theta$  about either principal axis through the centre of gravity of the surface section the couple acting on the body is

$$g\rho (Ak^2 - V \cdot HG) \theta.$$

Consequently the work that would have to be done by external agency in order to increase  $\theta$  by a small amount  $d\theta$  is

$$g\rho (Ak^2 - V \cdot HG) \theta d\theta,$$

and, by integration, it follows that the work done in producing the angular displacement  $\theta$  is

$$\frac{1}{2} g\rho (Ak^2 - V \cdot HG) \theta^2.$$

**69. Sufficiency of the conditions for stability.** A small rotation about any axis in the plane of flotation through the centre of gravity of the water-section may be regarded as compounded of rotations  $\theta_1$ ,  $\theta_2$  about the principal axes of the section. Each of these separately sets up a restoring couple and the total work that would have to be done by external agency, or the gain in potential energy, in producing the displacement is\*

$$\frac{1}{2} g\rho (I_1 - V \cdot HG) \theta_1^2 + \frac{1}{2} g\rho (I_2 - V \cdot HG) \theta_2^2.$$

Whence it follows that the conditions  $HG < I_1/V$  and also  $< I_2/V$  are sufficient to ensure stability for displacements which do not alter the volume of liquid displaced.

**70.** The question of stability may be treated somewhat differently.

Defining the *metacentre* as the point of intersection with the line  $HG$  of the vertical line through the new centre of buoyancy after a slight displacement, we are led to the following theorem;

*The metacentre is the centre of curvature of the curve of buoyancy at the point in the same vertical line with  $G$ .*

This is at once obvious from the fact that the point  $M$  is the point of intersection of consecutive normals to the curve.

\* That the expression for the work done in a displacement of this kind does not contain a term  $\theta_1\theta_2$  may be proved as in Art. 79 following.

Hence it appears that for any displacement, consistent with the condition that the volume displaced remains the same, the direction of the fluid pressure is always a vertical tangent to the evolute of the curve of buoyancy.

71. From the preceding theorem we can determine the expression for the height of the metacentre above the point  $H$ .

Let  $H$  be the centroid of the volume  $ADB$ , and  $H'$  of  $aDb$ ,  $aCA$  being a small angle  $\theta$ .

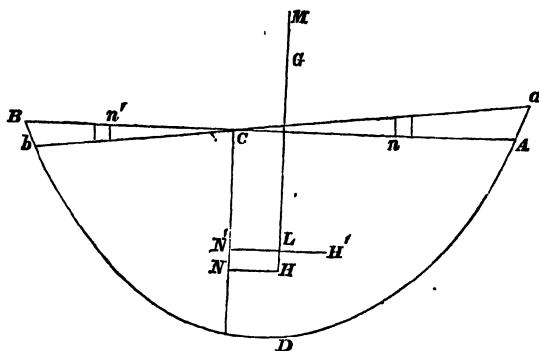

Then, if  $\alpha$  be an element of the area of the plane of flotation,  $H'N'$ ,  $HN$ , perpendiculars upon the vertical line through  $C$ ,

$$H'N' \cdot V - HN \cdot V = \Sigma (Cn \cdot \theta \cdot \alpha \cdot Cn) + \Sigma (Cn' \cdot \theta \cdot \alpha' \cdot Cn')$$

or

$$H'L \cdot V = \theta Ak^2$$

but, if  $M$  be the centre of curvature at  $H$ ,

$$H'L = H'M \cdot \theta = HM \cdot \theta,$$

$$\therefore V \cdot HM = k^2 A.$$

The restorative moment, for a small displacement  $\theta$ ,

$$= g\rho V \cdot GM \cdot \theta = g\rho\theta (Ak^2 - V \cdot HG).$$

72. The preceding article assumes that the vertical line of action of the fluid pressure, after a slight displacement, intersects  $HG$ . This will be true only when the plane of displacement is a principal section, at  $H$ , of the surface of buoyancy. When this is not the case, the projection of the line of action on the vertical plane of displacement will intersect  $HG$  in a point  $M$ , which will be the centre of curvature of the normal section of the surface.

The radius of curvature of any normal section at  $H$ , of the surface of buoyancy, is therefore  $Ak^2/V$ , and, if  $I$  and  $I'$  be the

principal moments of inertia of the plane of flotation at its centroid, the principal radii of curvature, at  $H$ , of the surface of buoyancy are

$$\frac{I}{V} \text{ and } \frac{I'}{V},$$

and the principal sections are parallel to the principal axes of the plane of flotation.

73. A most important case naturally presents itself; that is, the question of the stability of equilibrium of a ship when displaced by rolling.

In general it is impossible for a ship to roll without tossing, because the two ends of the ship are unsymmetrical; but in the case of a very long vessel, such as an Atlantic 'liner,' it may be

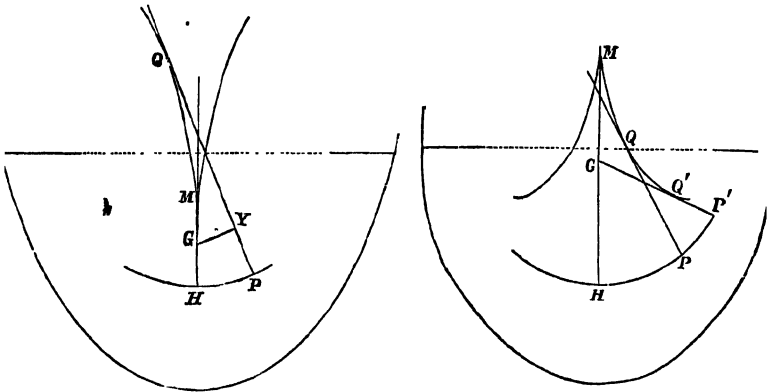

assumed that the ship can be divided symmetrically by a plane perpendicular to its length, and in this case the ship has two vertical planes of symmetry, and consequently the vertical line  $HG$  passes through the centroid  $C$  of the plane of flotation.

The line  $HG$  also divides the curve of buoyancy symmetrically, and the point  $H$  is a point of maximum or minimum curvature. In the first of these two cases the cusp of the evolute is pointed downwards; in the second case it is pointed upwards.

The figures at once shew the effects of displacement.

In the first case the righting moment, which is the statical measure of stability for a given angle of displacement, is proportional to  $GY$  the perpendicular from  $G$  on the tangent  $PQ$ , and increases with an increase in the angle of displacement.

In the second case, the righting moment increases to a maximum value, and then diminishes, vanishing for the position given by the tangent  $GQ'P'$ .

This is a position of equilibrium, but it is of unstable equilibrium, in accordance with the general mechanical law that positions of stable and unstable equilibrium occur alternately.

If the equation to the curve of buoyancy be obtained in the form  $p = f(\phi)$ ,  $G$  being the origin,

$$GY = dp/d\phi,$$

and the righting moment is

$$W dp/d\phi,$$

if  $W$  be the weight of the ship.

In general the curve of buoyancy, for moderate displacements, is approximately an arc of an hyperbola; in the case of a 'wall-sided' ship, that is of a ship with the sides vertical near the water-line, the curve is an arc of a parabola.

In the case of a ship, if  $M$  is the metacentre for rolling, the product  $W \cdot GM$  is called the *stiffness* of the vessel.

**74. Dupin's Theorem.** In the case of a ship floating upright, the radius of curvature of a transverse section of the surface of flotation is

$$r_1 = \int y^2 \tan \alpha ds / A,$$

$ds$  being an element of the perimeter, and  $A$  the area, of the water-section, and  $\alpha$  the inclination of the side of the ship to the vertical; the axes of  $x$  and  $y$  being the longitudinal and transverse axes of the section of the vessel by the plane of flotation through its centroid  $C$ .

To prove this let  $C, C'$  be contiguous points on the transverse section of the surface of flotation, the tangent plane at  $C'$  making a small angle  $\theta$  with the water-section  $APQB$ , and let  $apqb$  be the projection on the water-section of the section of the ship made by this tangent plane, so that  $E$ , the projection of  $C'$ , is the centroid of the area

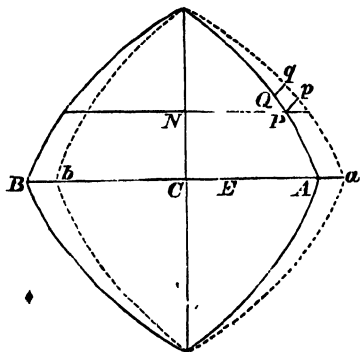

*apqb*. Let *PQ*, *pq* be corresponding elements, and  $PQ = ds$ , then

$$\begin{aligned} \text{area } PQqp &= y\theta \tan \alpha ds; \\ \therefore CE \cdot (A) &= \int y^2 \theta \tan \alpha ds, \end{aligned}$$

and, since  $CC' = r_1\theta$ , and  $CE = CC'$  ultimately, it follows that

$$r_1 A = \int y^2 \tan \alpha ds,$$

an expression first given by C. Dupin, in a memoir presented to the Académie des Sciences in 1814. A corresponding expression obviously exists for the radius of curvature ( $R_1$ ) of the longitudinal section.

**75. Leclert's Theorem.** Calling  $r$  and  $R$  the metacentric heights for transverse and longitudinal displacements, that is, the radii of curvature of transverse and longitudinal sections of the surface of buoyancy; we know that

$$r = \frac{i}{V} \text{ and } R = \frac{I}{V},$$

where  $i$  and  $I$  are the principal moments of inertia of the water-section. E. Leclert has established the following relations between these quantities;

$$r_1 = \frac{di}{dV} = r + \frac{Vdr}{dV}; \quad R_1 = \frac{dI}{dV} = R + V \frac{dR}{dV}.$$

A translation of Leclert's paper is given by Mr Merrifield in the *Proceedings*, for 1870, of the *Institution of Naval Architects*, and in the *Messenger of Mathematics*, March, 1872. The following is the first of the two proofs which are given; it is retained here for its historic interest, but a more rigorous treatment is given in Art. 80 following.

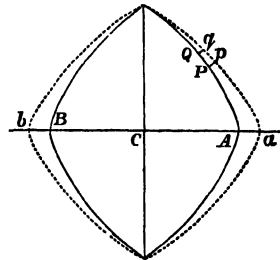

Taking a section parallel to the water-section, and at a distance  $dz$  from it,

$$dV = A dz.$$

Let *apqb* be the projection of this new section upon the water-section; then  $di$  is the moment of inertia of the area between *apqb* and  $APQB$ ;

$$\therefore di = \Sigma y^2 dz \cdot \tan \alpha ds,$$

and 
$$\frac{di}{dz} = \int y^2 \tan \alpha ds.$$

Hence 
$$r_1 = \frac{1}{A} \frac{di}{dz} = \frac{di}{dV};$$

$$\therefore r_1 - r = \frac{di}{dV} - \frac{i}{V} = \frac{Vdi - idV}{VdV},$$

or 
$$r_1 = r + \frac{Vdr}{dV}.$$

**76. Increase in load.** . Effect of a slight increase in the load of a ship on the position of the metacentre.

Assuming that a ship has two vertical planes of symmetry, let  $C$  be the centroid of the plane of flotation, and consider the stability in one of these planes.

Taking  $C'$  as the new position of  $C$  when the load is slightly increased, let  $\delta V$  represent the additional displacement.

Then, if  $H'$  and  $M'$  are the new positions of  $H$  and  $M$ ,

$$\begin{aligned} MM' &= H'M' - HM + HH' \\ &= \delta r + HH'; \end{aligned}$$

but  $CH' \cdot \delta V = V \cdot HH'$ ,

$$\therefore MM' = \delta r + CH \frac{\delta V}{V} = \frac{\delta V}{V} (r_1 - r + CH),$$

$r_1$  representing  $CD$ , the radius of curvature of the surface of flotation.

Hence 
$$\begin{aligned} MM' &= \frac{\delta V}{V} (CD - HM + CH) \\ &= \frac{\delta V}{V} (HD - HM), \end{aligned}$$

so that the metacentre is elevated or depressed, relative to the ship, according as the metacentre is below or above the centre of curvature of the surface of flotation.

**77. Heeling over of a screw-steamer due to the action of its screw\*.**

If  $L$  is the turning couple of the engine, measured in foot-

\* This article is due to Prof. Greenhill.

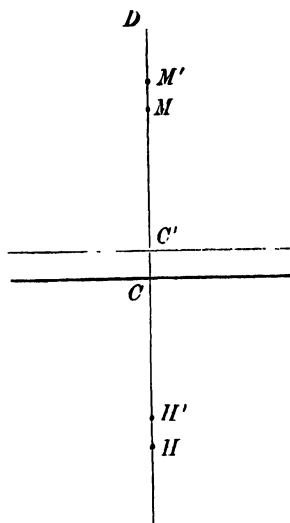

pounds, and if  $n$  is the number of revolutions per minute, the work done in one minute is  $2\pi nL$ . But, if  $H$  is the horse-power at which the engine is working,

$$\text{the work done} = 33000 H;$$

$$\therefore 2\pi nL = 33000 H.$$

If  $\theta$  is the angle through which the steamer heels over,  $h$  the height of the metacentre above the centre of gravity, and  $W$  the weight of the steamer in tons,

$$L = 2240 Wh \sin \theta;$$

$$\therefore 33000 H = 2\pi n \times 2240 Wh \sin \theta,$$

an equation which determines  $\theta$ .

The heeling effect can be counteracted by placing a weight  $w$  at a given distance  $c$  from the medial plane, such that

$$w \cdot c = L,$$

or

$$2\pi n cw = 33000 H.$$

In the case of a paddle steamer, the heeling over will be in the longitudinal direction, and in this case  $h$  will be the longitudinal metacentric height.

It will be seen that the heeling over is in the opposite direction to the rotation. Thus, in the case of a paddle steamer going ahead, the bow is slightly lifted and the stern is slightly sink.

### 78. Surface of buoyancy in general.

Let the origin be taken in the vertical through the centroid of the original waterline section. Then if  $z = c$  be the original section, the plane in the slightly displaced position will be

$$z = c + lx + my$$

where  $l, m$  are small.

If  $(x_0, y_0, z_0)$  and  $(x, y, z)$  denote the co-ordinates of the centre of buoyancy in the two positions

$$V(x - x_0) = \iint (z - c) x dx dy = al + hm,$$

$$V(y - y_0) = \iint (z - c) y dx dy = hl + bm,$$

$$V(z - z_0) = \iint \frac{1}{2} (z^2 - c^2) dx dy = \frac{1}{2} (a l^2 + 2 h l m + b m^2),$$

where  $a = \iint x^2 dx dy$ ,  $h = \iint xy dx dy$ ,  $b = \iint y^2 dx dy$ .

$$\text{Hence } 2(z - z_0) = l(x - x_0) + m(y - y_0)$$

$$\text{or } 2(z - z_0) = \frac{V}{ab - h^2} \{b(x - x_0)^2 - 2h(x - x_0)(y - y_0) + a(y - y_0)^2\},$$

is the approximate form of surface of buoyancy. If the original axes of  $x$  and  $y$  are principal axes of the plane section then  $h = 0$ , and if the origin be now moved to the centre of buoyancy in the first position the surface becomes

$$2z = Vx^2/a + Vy^2/b.$$

If we now define the **metacentres** as the centres of curvature of the principal normal sections of the surface of buoyancy, the heights of the metacentres above the centre of buoyancy are the principal radii of curvature  $a/V$  or  $b/V$ .

### 79. Condition for stability.

The tangent plane to the surface of buoyancy at a point  $(x, y, z)$  is given by

$$\zeta - z = \frac{Vx}{a}(\xi - x) + \frac{Vy}{b}(\eta - y).$$

And the perpendicular distance of the centre of gravity  $(0, 0, \bar{z})$  of the solid from this plane is

$$\begin{aligned} & \left\{ \bar{z} - z + \frac{Vx^2}{a} + \frac{Vy^2}{b} \right\} \left\{ 1 + \frac{V^2x^2}{a^2} + \frac{V^2y^2}{b^2} \right\}^{-\frac{1}{2}} \\ &= \left\{ \bar{z} + \frac{Vx^2}{2a} + \frac{Vy^2}{2b} \right\} \left\{ 1 - \frac{V^2x^2}{2a^2} - \frac{V^2y^2}{2b^2} \right\} \\ &= \bar{z} + \frac{V^2x^2}{2a^2} \left( \frac{a}{V} - \bar{z} \right) + \frac{V^2y^2}{2b^2} \left( \frac{b}{V} - \bar{z} \right). \end{aligned}$$

Now by Art. (55) the positions of equilibrium correspond to those of a heavy body bounded by the surface of buoyancy on a horizontal plane, so that for stability the height of the centre of gravity above the plane must be a minimum. This requires that  $\bar{z}$  should be less than  $\frac{a}{V}$  and  $\frac{b}{V}$ , or the centre of gravity must be below both metacentres.

### 80. Surface of Flotation. Leclert's Theorem.

Suppose that the volume immersed is increased by a small amount  $\delta V$  by depressing the solid from the second position of Art. 78.

If  $\xi, \eta, \zeta$  are the co-ordinates of the centre of gravity of the thin slice, of volume  $\delta V$ , we have

$$\begin{aligned} \xi \delta V &= (V + \delta V)(x - x_0 + \delta x - \delta x_0) - V(x - x_0) \\ &= l \delta a + m \delta h; \quad \text{Art. 78.} \end{aligned}$$

Similarly  $\eta \delta V = l \delta h + m \delta b$ ;  
 and  $\zeta \delta V = \frac{1}{2} (l^2 \delta a + 2lm \delta h + m^2 \delta b)$ .

Also as the thickness of the slice is diminished the point  $(\xi, \eta, \zeta)$  tends to coincide with the corresponding point on the surface of flotation, i.e. the centroid of the water-line area.

Hence on the surface of flotation we have

$$\begin{aligned} x' \cdot dV &= l da + m dh \\ y' \cdot dV &= l dh + m db \\ z' \cdot dV &= \frac{1}{2} (l^2 da + 2lmdh + m^2 db), \end{aligned}$$

and its equation is

$$2z' = \frac{dV}{da db - (dh)^2} \{x'^2 db - 2x'y'dh + y'^2 da\}.$$

In the special case in which  $dh = 0$ , this becomes

$$2z' = x'^2 \frac{dV}{da} + y'^2 \frac{dV}{db},$$

and the radii of curvature of the surface of flotation are  $\frac{da}{dV}$  and  $\frac{db}{dV}$  as in Art. 75.

We observe that the principal axes of two parallel sections of the solid are not necessarily parallel, so that  $h = 0$  does not imply that  $dh/dV = 0$ . The results of Art. (75) are thus seen to be true only in the cases there implied in which there are vertical planes of symmetry which contain all principal axes of horizontal sections\*.

81. We now append some examples of the determination of the metacentre.

Ex. 1. *A solid cylinder of radius a, and length h floating with its axis vertical.*

In this case the plane of flotation is a circular area, and

$$\begin{aligned} Ak^2 &= 4 \int_0^a \frac{1}{2} y^3 dx = \frac{1}{2} \int_0^a (\alpha^2 - x^2)^{\frac{3}{2}} dx \\ &= \frac{1}{2} \alpha^4 \int_0^{\frac{\pi}{2}} \cos^4 \theta d\theta, \text{ putting } x = a \sin \theta \\ &= \frac{\pi \alpha^4}{4}; \end{aligned}$$

therefore, if  $h'$  be the length of the axis immersed,

$$\pi \alpha^2 h' \cdot HM = \frac{\pi \alpha^4}{4}, \text{ or } HM = \frac{\alpha^2}{4h'},$$

\* This correction to Leclert's Theorem and the method of treatment of the last few Articles as well as Arts. 90-92, 104, 105 below are due to Dr Bromwich.

and the equilibrium is stable if

$$\frac{a^2}{4h} > \frac{h}{2} - \frac{h'}{2}.$$

Ex. 2. *A cylinder floating with its axis horizontal and in the surface is displaced in the vertical plane through the axis.*

The plane of flotation is a rectangle, and

$$Ak^2 = \frac{1}{3} ah^3,$$

$h$  being the length of the cylinder, and  $a$  its radius;

$$\therefore HM = \frac{1}{3} \frac{h^2}{\pi a};$$

and the equilibrium is stable, if

$$\frac{1}{3} \frac{h^2}{\pi a} > \frac{4a}{3\pi},$$

or

$$h > 2a.$$

Ex. 3. *A solid cone floating with its axis vertical and vertex downwards.*

Let  $h$  be the length of the axis,

$z$  the portion of the axis immersed,

$2a$  the vertical angle of the cone.

Then

$$Ak^2 = \frac{1}{4} \pi z^4 \tan^4 a,$$

and

$$V = \frac{1}{3} \pi z^3 \tan^2 a;$$

$$\therefore HM = \frac{1}{4} z \tan^2 a;$$

also

$$HG = \frac{1}{4} h - \frac{1}{4} z,$$

and therefore the equilibrium is stable or unstable, according as

$$z \tan^2 a > \text{or} < h - z,$$

or

$$z > \text{or} < h \cos^2 a.$$

But if  $\rho$ ,  $\sigma$  be the densities of the fluid and cone,

$$\left(\frac{z}{h}\right)^3 = \frac{\sigma}{\rho};$$

therefore the equilibrium is stable or unstable as

$$\frac{\sigma}{\rho} > \text{or} < (\cos a)^3.$$

Ex. 4. *An isosceles triangular prism floating with its base not immersed, and its edges horizontal.*

Referring to Art. (49), consider first the position of equilibrium in which the base is inclined to the horizon.

In this case, if  $AQ = 2y$  and  $AP = 2x$ , and we put  $\alpha = \theta$  in equation (8) on page 53,  $x$  and  $y$  are given by the equations

$$x + y = 2a \cos^2 \frac{\theta}{2},$$

$$xy = c^2.$$

The co-ordinates of  $G$  and  $H$  referred to  $AB$ ,  $AC$  as axes are respectively,

$$\frac{2}{3}a, \frac{2}{3}a, \text{ and } \frac{2}{3}x, \frac{2}{3}y,$$

$$\begin{aligned} \therefore HG^2 &= \frac{4}{3} \{ (a-x)^2 + (a-y)^2 + 2(a-x)(a-y)\cos\theta \} \\ &= \frac{4}{3} \{ x^2 + y^2 + 2xy\cos\theta - 2a(1+\cos\theta)(x+y) + 2a^2(1+\cos\theta) \}, \end{aligned}$$

from which, by means of the above equations, we obtain

$$HG = \frac{4}{3} \sin \frac{\theta}{2} \left( a^2 \cos^2 \frac{\theta}{2} - c^2 \right)^{\frac{1}{2}}.$$

The area  $PAQ = 2c^2 \sin \theta$ , and if  $M$  be the metacentre, and  $l$  the length of the prism,

$$2c^2 \sin \theta \cdot HM = \frac{PQ^2}{12} \cdot PQ \cdot l,$$

$$\therefore HM = \frac{PQ^3}{24c^2 \sin \theta}.$$

But

$$\begin{aligned} PQ^2 &= 4(x^2 + y^2 - 2xy\cos\theta) \\ &= 16 \cos^2 \frac{\theta}{2} \left( a^2 \cos^2 \frac{\theta}{2} - c^2 \right); \end{aligned}$$

$$\therefore HM = \frac{4}{3} \frac{\cos^2 \frac{\theta}{2}}{c^2 \sin \frac{\theta}{2}} \left( a^2 \cos^2 \frac{\theta}{2} - c^2 \right)^{\frac{3}{2}},$$

and

$$HM > HG, \text{ if } c^2 \sin^2 \frac{\theta}{2} < \cos^2 \frac{\theta}{2} \left( a^2 \cos^2 \frac{\theta}{2} - c^2 \right),$$

i.e. if

$$\cos^2 \frac{\theta}{2} > \frac{c}{a}.$$

Next, consider the case in which the base is horizontal, and  $PQ$  therefore, parallel to  $BC$ .

The area  $PAQ = 2c^2 \sin \theta$ ,

$$AP = AQ = 2c, \text{ and } PQ = 4c \sin \frac{\theta}{2}.$$

$$\text{Hence, } HM = \frac{4}{3} c \frac{\sin^2 \frac{\theta}{2}}{\cos \frac{\theta}{2}}, \text{ and } HG = \frac{4}{3} (a-c) \cos \frac{\theta}{2},$$

and

$$HM > HG \text{ if } \cos^2 \frac{\theta}{2} < \frac{c}{a}.$$

Now in the Art. (49), before referred to, we have shewn that there are three positions of equilibrium, or one only, according as

$$\cos^2 \frac{\theta}{2} > \text{ or } < \frac{c}{a}.$$

Hence it follows, that when there are three positions of equilibrium, the intermediate one, in which  $CB$  is horizontal, is a position of unstable equilibrium, while in the other two positions the equilibrium is stable.

If there be only one position in which the prism will rest, its equilibrium is stable.

It will be a useful exercise for the student to obtain these results by investigating the equation to the curve of buoyancy, and determining the position of its centre of curvature.

**82. Finite displacements.** If a solid body, floating in water, be turned through any given angle from its position of equilibrium, then, as before, the moment of the fluid pressure is restorative or not according as the point  $L$  at which the vertical through the new centre of buoyancy meets the line  $HG$  is above or below  $G$ .

It is not to be inferred that if  $L$  is above  $G$ , the body will when set free return to its original position and oscillate through it, or even that the original position is one of stable equilibrium, according to our previous definition of stability: it is a general law of mechanics that positions of stable and unstable equilibrium occur alternately, and the body may have been displaced from its original position through other positions of equilibrium.

As a particular example take the following

*A solid cone, floating with its axis vertical and vertex downwards, is turned through an angle  $\theta$  in a vertical plane, the volume of fluid displaced remaining the same; to determine the direction of the moment of the fluid pressure.*

Let  $AB$  be the major axis of the elliptic section made by the surface plane of the fluid,  $C$  its middle point,  $Aa, Bb, Cc$ , lines at right angles to  $AB$ , and let the angle  $AVB = 2a$  and  $VA = d$ . Then

$$VAa = \theta - a,$$

and 
$$VBb = \pi - \theta - a.$$

$$\begin{aligned} Vc &= \frac{1}{2}(Va + Vb) = \frac{1}{2} \cdot \left\{ d \frac{\sin(\theta - a)}{\sin \theta} \right. \\ &\quad \left. + d \frac{\cos(\theta - a)}{\cos(\theta + a)} \frac{\sin(\theta + a)}{\sin \theta} \right\} \\ &= \frac{d \cos \theta}{\cos(\theta + a)}; \end{aligned}$$

$$\therefore VL = \frac{3}{4} d \frac{\cos \theta}{\cos(\theta + a)}.$$

The semi-minor axis of the ellipse  $AB$  is a mean proportional between the perpendiculars from  $A$  and  $B$  on the axis of the cone,

$$\begin{aligned} \therefore \text{its area} &= \pi \frac{1}{2} AB (VA \cdot VB \cdot \sin^2 a)^{\frac{1}{2}} \\ &= \frac{\pi}{2} d^2 \frac{\sin a \sin 2a}{\cos(\theta + a)} \cdot \left\{ \frac{\cos(\theta - a)}{\cos(\theta + a)} \right\}^{\frac{1}{2}}; \end{aligned}$$

therefore the volume of the fluid displaced

$$\begin{aligned} &= \frac{1}{3} d \cos(\theta - a) \cdot (\text{area of ellipse}) \\ &= \frac{1}{3} \pi d^3 \sin^2 a \cos a \left\{ \frac{\cos(\theta - a)}{\cos(\theta + a)} \right\}^{\frac{3}{2}}. \end{aligned}$$

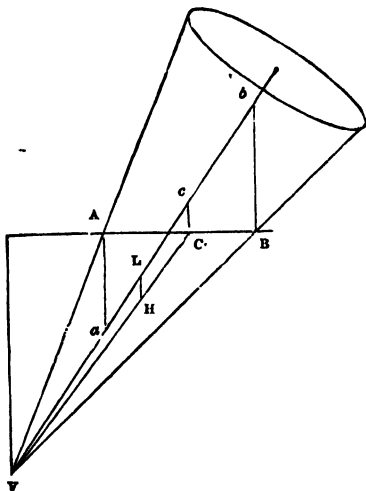

Hence, if  $\rho$ ,  $\sigma$  be the densities of the fluid and the cone, since the weight of the fluid displaced is equal to that of the cone, we have

$$\rho a^3 \sin^2 a \cos a \left\{ \frac{\cos(\theta - a)}{\cos(\theta + a)} \right\}^{\frac{3}{2}} = \sigma h^3 \tan^2 a,$$

or 
$$\left( \frac{a}{h} \right)^3 = \frac{\sigma}{\rho} \left\{ \frac{\cos(\theta + a)}{\cos(\theta - a)} \right\}^{\frac{3}{2}} \frac{1}{\cos^2 a}.$$

And  $VL > VG$  if 
$$d \frac{\cos \theta}{\cos(\theta + a)} > h,$$

or if 
$$\sqrt[3]{\frac{\sigma}{\rho}} > \frac{\cos a \cos(\theta + a)}{\cos \theta} \cdot \left\{ \frac{\cos(\theta - a)}{\cos(\theta + a)} \right\}^{\frac{1}{2}}.$$

Supposing  $\theta$  indefinitely small, we obtain the condition of stability for an infinitesimal displacement,

$$\sqrt[3]{\frac{\sigma}{\rho}} > \cos^2 a; \text{ as before, Ex. 3, Art. (81).}$$

Let the equilibrium of the cone be neutral, that is, let

$$\sigma = \rho \cos^2 a,$$

then, after a finite displacement, the action of the fluid will tend to restore the cone to its original position, if

$$\cos a \cdot \cos \theta > \sqrt{\cos(\theta + a) \cdot \cos(\theta - a)},$$

a condition which is always true,  $a$  and  $\theta$  being each less than a right angle.

In the case of neutral equilibrium of a cone, the equilibrium may therefore be characterised as stable for any finite displacement.

**83.** When liquid is contained in a vessel, which is slightly displaced from its original position, the preceding investigations enable us to determine the line of action of the resultant *downward* pressure.

The problem in fact in this case, as in the previous case, is the following.

A given volume, the centroid of which is  $H$ , is cut from a solid  $ABC$  by a plane, and the line  $CH$  is perpendicular to the plane; the same volume being cut off by a plane making a very small angle with the plane  $AB$ , to determine the position of the straight line perpendicular to the second plane, and passing through the centroid of the volume cut off by it.

If the interior surface of the vessel is symmetrical with respect to the plane through  $H$  perpendicular to the line of intersection of the two planes, the line whose position is required will intersect  $CH$  in a point  $M$ , the *metacentre*, the position of which is determined by our previous results.

**84. Vessel containing liquid.** *A hollow vessel containing liquid, floats in liquid; required to determine the nature of the equilibrium, supposing that the body is symmetrical with respect to the vertical plane of displacement through its centre of mass, and that the centres of mass of the body and of the liquid are in the same vertical line.*

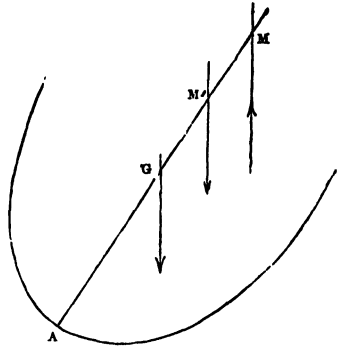

Let  $M$  be the metacentre for the displaced fluid, and  $M'$  for the contained fluid,  $W, W'$ , the weights of the displaced and contained fluid\*.

Taking moments about  $G$ , the centre of mass of the vessel, the resultant fluid pressures will tend to restore equilibrium, or the reverse, according as

$$W \cdot GM - W' \cdot GM'$$

is positive or negative, i.e. as

$$\frac{W}{W'} > \text{or} < \frac{GM'}{GM}.$$

*Ex. A hollow cone containing water floats in water with its axis vertical.*

Let  $h$  = the length of the axis of the cone,

$h'$  = the length of the axis in the contained fluid,

$z$  = the length beneath the surface of the external fluid.

Taking  $2a$  as the vertical angle of the cone, we have

$$HM = \frac{1}{4} z \tan^2 a.$$

But

$$HG = \frac{2}{3} h - \frac{2}{3} z;$$

$$\therefore GM = \frac{1}{4} z \sec^2 a - \frac{2}{3} h.$$

Similarly

$$GM' = \frac{2}{3} h' \sec^2 a - \frac{2}{3} h,$$

also

$$\frac{W}{W'} = \frac{z^3}{h'^3};$$

therefore the equilibrium is stable if

$$\left(\frac{z}{h}\right)^3 > \frac{9h' \sec^2 a - 8h}{9z \sec^2 a - 8h},$$

$z$  being given by the equation

$$W - W' = \frac{1}{3} g \rho \pi \tan^2 a (z^3 - h'^3) = \text{weight of cone.}$$

\* This is the case of a leaky ship rolling; the next article discusses the pitching of a leaky ship.

**85.** In the case in which the centres of mass of the contained and of the displaced fluid are not in the same vertical, suppose the displacement to take place in direction of the vertical plane through the centres of mass, and that the body is symmetrical with respect to that plane.

Let  $G$  be the centre of mass of the body,  $H$  of the fluid displaced,  $H'$  of the contained fluid, and  $M, M'$ , the metacentres.

Also let  $GNN'$  be horizontal in the position of equilibrium, and  $GLL'$  the horizontal line through  $G$  in the displaced position.

Then  $W, W'$ , having the same meanings as before, and  $\theta$  being the angle of displacement, the equilibrium is stable or unstable, as

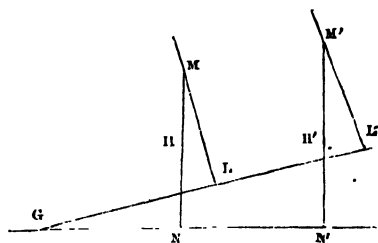

$$W \cdot GL > \text{or} < W' \cdot GL',$$

or  $W(GN \cos \theta + MN \sin \theta) > \text{or} < W'(GN' \cos \theta + M'N' \sin \theta),$

i.e. since

$$W \cdot GN = W' \cdot GN',$$

as

$$\frac{W}{W'} > \text{or} < \frac{M'N'}{MN}.$$

**86. Constraints.** *Stability of the equilibrium of bodies floating under constraint.*

In those cases of constraint, in which, for a small displacement, the volume of liquid displaced remains unchanged, the theory of the metacentre determines the line of action of the fluid pressure, and the question of stability is then easily determined.

Suppose, for instance, that a body, partially immersed, is moveable about a horizontal axis, which is vertically beneath the centroid ( $C$ ) of the plane of section of the body by the surface of the liquid.

The effect of a displacement through a small angle  $\theta$  will be to depress the point  $C$  through a space which depends upon  $\theta^2$ , and therefore, to the first order of small quantities, the volume displaced remains unchanged, and the metacentre is the same as if  $C$  remained in the surface.

If the body be moveable about a horizontal axis which is not vertically beneath the point  $C$ , the change in the volume displaced cannot be neglected, and the question of stability must be treated by a direct consideration of the action of the displaced liquid.

Ex. A rectangular lamina rests in a liquid of twice its own density with two of its sides vertical, and is moveable in its own plane about the middle point of one of its vertical sides.

The figure represents the lamina when slightly displaced through an angle  $AOB$ , ( $\theta$ ), the point  $O$  which is in the surface being the middle point.

Then if  $OA = a$ , and if the height =  $2b$ ,  
 the area  $AOB = \frac{1}{2}a^2\theta$ ,  
 and, taking moments about  $O$ , the equilibrium is stable if

$$2\rho \left( \frac{1}{2}a^2\theta \cdot \frac{2}{3}a + ab \cdot ON \right) > \rho \cdot 2ab \cdot \frac{a}{2},$$

$HN$  being the vertical through  $H$ ; or, since

$$ON = OG \cos \theta - HG \sin \theta = \frac{a}{2} - \frac{b}{2} \theta,$$

if  $2a^2 > 3b^2$ .

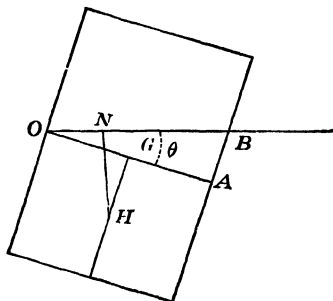

87. In the particular case in which the centre of mass of the body and the axis about which it is moveable are in the surface of the liquid, a formula can be given, for the determination of stability, analogous to that of Art. (66).

Take  $Cy$  as the axis about which the body is moveable, and  $V$  as the volume of the displaced liquid in the position of equilibrium.

Let  $ACa$  be the original plane of flotation, and  $BCb$  the water line after displacement through a small angle  $\theta$ , about the axis  $Cy$ , perpendicular to the plane of the paper.

The resulting fluid pressure is the weight  $BDab$  acting upwards and is therefore equivalent to the weight  $ABDa$ , or  $g\rho V$ , acting upwards, of the wedge  $aCb$  acting upwards, and of the wedge  $ACB$  acting downwards.

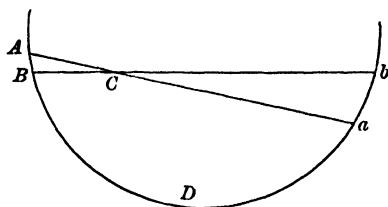

The restorative moment due to the two wedges

$$= \iint g\rho x^2\theta dx dy = g\rho Ak^2\theta,$$

$Ak^2$  being the moment of inertia about  $Cy$  of the area  $ACa$ ; and the loss of moment due to the displacement of  $H$

$$= g\rho V \cdot NN' = g\rho V \cdot HN \cdot \theta.$$

The equilibrium is therefore stable if

$$Ak^2 > V \cdot HN.$$

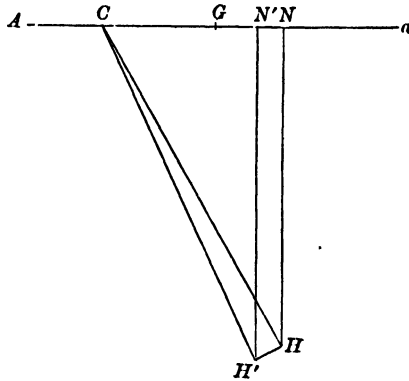

88. In the general case of a body moveable about a horizontal axis at depth  $h$ , let  $Cy$  be the projection of the axis on the plane of flotation, and let  $L$  and  $N$  be the projections of  $G$  and  $H$ .

For a small angular displacement  $\theta$ , the vertical displacement of  $C$  will be of the order  $\theta^2$ , and may therefore be neglected.

As in the previous article, the restorative moment due to the change of the displaced liquid  $= g\rho Ak^2\theta$ , and the loss of moment due to the displacement of  $H = g\rho V \cdot (HN - h) \cdot \theta$ .

But there is also a loss of the moment of the weight of the body due to the displacement of  $G$ , and this  $= W \cdot (GL - h) \theta$ .

Hence it follows that the test of stability is that

$$g\rho Ak^2 - g\rho V \cdot (HN - h) + W (GL - h)$$

must be positive, with the condition

$$W \cdot CL = g\rho V \cdot CN.$$

COR. If a body, floating freely in homogeneous liquid, has a plane of symmetry and is turned through a small angle  $\theta$  about *any* horizontal axis in the plane of symmetry, the restorative couple is  $g\rho\theta (Ak^2 - V \cdot HG)$ , where  $Ak^2$  is the moment of inertia of the surface section about its intersection with the plane of symmetry.

89. *The equilibrium of a body floating partially immersed in two liquids.*

Let  $\rho$  be the density of the upper liquid, and  $\rho + \rho'$  the density of the lower liquid.

Also let  $V$  be the total volume immersed and  $V'$  the portion of  $V$  immersed in the lower liquid, and let  $A, A'$  be the areas of the two planes of flotation. Then the forces which support the weight of the body are the weights of the masses of liquid  $\rho V$  and  $\rho' V'$ , supposed to act upwards.

Take the case in which the body is symmetrical with regard to a vertical plane perpendicular to the plane of displacement, so that the centroids,  $G, H, H'$ , of the body and of the masses  $\rho V, \rho' V'$  are in the same vertical line.

Then, if the body is displaced through a small angle  $\theta$  about any horizontal axis in the plane of symmetry, the total moment about  $G$  of the forces tending to restore equilibrium is

$$g\rho(Ak^2 - V.HG)\theta + g\rho'(A'k'^2 - V'.H'G).\theta,$$

or

$$g\rho V.GM.\theta + g\rho'V'.GM'.\theta,$$

in which the positive direction of  $GM, GM'$  is upwards.

The equilibrium is clearly stable if  $M$  and  $M'$  are both above  $G$ ; but if  $M'$  is below  $G$ , for stability we must have

$$\rho V.GM > \rho'V'.M'G,$$

or

$$\rho(Ak^2 - V.HG) > \rho'(V'.H'G - A'k'^2).$$

**90. Heterogeneous liquid.** *Surface of buoyancy for a solid floating in a liquid of variable density.*

Consider first the case of a body floating in a liquid formed of layers of different densities  $\rho_1, \rho_2 \dots \rho_n$  in descending order.

Let  $v_n$  denote the total volume of the solid immersed below the upper surface of the layer of density  $\rho_n$ .

As in Art. 78 let  $z = c$  be the original water line section, and let  $z = c + lx + my$  denote the plane in a slightly displaced position, then we have

$$\begin{aligned} & \{\rho_1 v_1 + (\rho_2 - \rho_1) v_2 + (\rho_3 - \rho_2) v_3 + \dots + (\rho_n - \rho_{n-1}) v_n\} (x - x_0) \\ & = \{\rho_1 a_1 + (\rho_2 - \rho_1) a_2 + \dots + (\rho_n - \rho_{n-1}) a_n\} l \\ & + \{\rho_1 h_1 + (\rho_2 - \rho_1) h_2 + \dots + (\rho_n - \rho_{n-1}) h_n\} m; \end{aligned}$$

and corresponding equations for  $(y - y_0)$  and  $(z - z_0)$  when  $(x_0, y_0, z_0)$ ,  $(x, y, z)$  are the centres of buoyancy in the two positions, and  $a_r, h_r, b_r$  denote

$$\iint x^2 dx dy, \quad \iint xy dx dy, \quad \iint y^2 dx dy$$

taken over the corresponding section.

Proceeding to the case of a continuous fluid we get

$$M(x - x_0) = Al + Hm,$$

$$M(y - y_0) = Hl + Bm,$$

and 
$$M(z - z_0) = \frac{1}{2}(Al^2 + 2Hlm + Bm^2),$$

where 
$$M = \rho_1 v_1 + \int_1^n v \, d\rho$$

$$= \rho_1 v_1 + [\rho v]_1^n - \int_1^n \rho \, dv$$

$$= \int_n^1 \rho \, dv,$$

and 
$$A = \rho_1 a_1 + \int_1^n a \, d\rho$$

$$= \rho_1 a_1 + [\rho a]_1^n - \int_1^n \rho \, da$$

$$= \rho_n a_n + \int_n^1 \rho \, da,$$

and a like expression for  $B$ , the suffixes 1,  $n$  referring to the top and bottom sections of the immersed solid,  $v_n$  being in this case clearly zero, and  $a_n$  is also zero except when the solid has a flat bottom.

The surface of buoyancy is obtained from three equations as in Art. 78, and, in the special case in which  $H = 0$ , and the origin is at the equilibrium position of the centre of buoyancy, the equation becomes

$$2z = Mx^2/A + My^2/B,$$

and the metacentric heights are  $A/M$  and  $B/M$ .

**91. Solid floating wholly immersed.**

In this case we have similar equations, with

$$M = \int_n^1 \rho \, dv, \text{ and } A = \int_1^n a \, d\rho \text{ or } (\rho_n a_n - \rho_1 a_1) + \int_n^1 \rho \, da,$$

there being no displacement of the centre of buoyancy with a solid immersed in homogeneous fluid.

**92. EXAMPLES.** (1) *Cone of semiangle  $a$  vertex downwards.*

If  $x$  is the distance of a section from the vertex  $O$ , we have

$$a = \frac{1}{2} \pi x^2 \tan^2 a,$$

$$\therefore da = \pi x \tan^2 a \, dx.$$

Also  $dc = \pi x^2 \tan^2 a \, dx$ , so that  $da = x \tan^2 a \, dv$ ,

and 
$$A/M = \int \rho da / \int \rho dv = \tan^2 a \int x \rho dr / \int \rho dv$$

$$= \bar{x} \tan^2 a,$$

where  $\bar{x}$  is the height of the centre of buoyancy above  $O$ , and thus the height of the metacentre above  $O$  is  $\bar{x} \sec^2 a$ .

(2) *Paraboloid of latus rectum  $l_0$ , vertex downwards.*

Here  $a = \frac{1}{2} \pi l_0^2 x^2$ ,  $\therefore du = \frac{1}{2} \pi l_0^2 x dx$ .

Also  $dv = \pi l_0 x dx$ , so that  $du = \frac{1}{2} l_0 dv$ ,

and  $A/M = \int \rho du / \int \rho dv = \frac{1}{2} l_0$ .

(3) *Cylinder with axis vertical.*

Here  $a = \text{constant}$ , so that  $A/M = \rho_n a_n / M$ .

**93. Potential Energy.** The theory of the stability of the equilibrium of floating bodies may also be based on the principle of energy and we proceed to the treatment of the subject from this point of view.

*To find the work done in inserting a body in a sea of heavy liquid; neglecting the alteration in the level of the liquid, and the disturbance caused by the insertion of the body.*

If a vertical prism of cross section  $dxdy$  cuts the boundary of the body in contact with the liquid in elements  $dS_1, dS_2$ , at depths

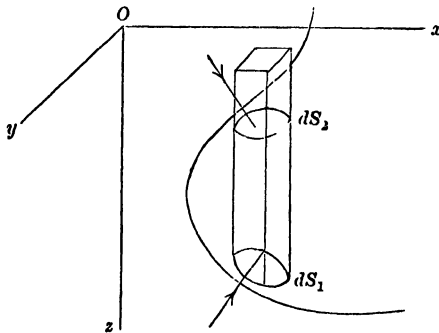

$z_1, z_2$ , at which the pressures are  $p_1, p_2$  respectively, and  $\theta_1, \theta_2$  are the acute angles which the normals to  $dS_1, dS_2$  make with the vertical; then the work done against the thrusts on these elements, as the depth is increased by a small amount  $dz$ , is

$$(p_1 dS_1 \cos \theta_1 - p_2 dS_2 \cos \theta_2) dz = (p_1 - p_2) dxdydz.$$

Therefore the work done in placing the body in the position under consideration

$$\begin{aligned} &= \Sigma \left\{ dxdy \left( \int_0^{z_1} p_1 dz - \int_0^{z_2} p_2 dz \right) \right\} \\ &= \Sigma \left\{ dxdy \int_{z_2}^{z_1} p dz \right\} \\ &= \iiint p dxdydz \dots \dots \dots (1), \end{aligned}$$

where the integration extends to the volume immersed.

If the liquid be homogeneous  $p = g\rho z$  and the work done

$$= g\rho \iiint z dx dy dz$$

$$= g\rho V\bar{z},$$

where  $V$  is the volume of liquid displaced, and  $\bar{z}$  the depth of its centroid.

When a body floats in a liquid it possesses potential energy in virtue of the work that has been done in placing it in the liquid; and if the liquid be homogeneous, and  $G, H$  the centres of mass of the body and of the liquid displaced, and  $\zeta$  and  $\bar{z}$  their depths, the measure of the potential energy of the body may be taken to be  $g\rho V(\bar{z} - \zeta)$ , or, when the body floats in equilibrium,  $g\rho V \cdot HG^*$ .

94. To find the work done in turning a floating body through a small angle  $\theta$  about any axis in the plane of flotation.

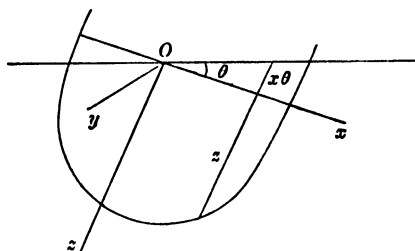

Let  $Oy$  be the axis of rotation,  $Oz$  vertically downwards, and let the plane  $xOz$  contain the centre of mass  $G$  of the body and the centre of buoyancy  $H$ . Let the co-ordinates of  $H$  and  $G$  be  $(x, 0, \bar{z})$  and  $(\xi, 0, \zeta)$  respectively, so that in equilibrium  $x = \xi$ .

In the initial position the potential energy due to the displaced liquid

$$= g\rho V\bar{z} \text{ or } \frac{1}{2}g\rho \iint z^2 dx dy.$$

Turn the body about  $Oy$  through a small angle  $\theta$  and let the axes  $Ox, Oz$  move with the body.

The length to the surface of the prism of cross section  $dx dy$  immersed in the liquid becomes  $z + x \tan \theta = z + x\theta$ , and the depth

\* The zero configuration is a hypothetical one, in which the space occupied by the body in the liquid is filled with liquid of the same kind, and the whole mass of the body is at the level of the free surface of the liquid.

of its centre of mass is  $\frac{1}{2}(z + x\theta) \cos \theta$ ; therefore the increase in the potential energy due to the displaced liquid

$$\begin{aligned} &= \frac{1}{2}g\rho \iint (z + x\theta)^2 \left(1 - \frac{\theta^2}{2}\right) dx dy - \frac{1}{2}g\rho \iint z^2 dx dy \\ &= \frac{1}{2}g\rho\theta^2 \iint \left(x^2 - \frac{z^2}{2}\right) dx dy + g\rho\theta \iint xz dx dy. \end{aligned}$$

But the loss of potential energy due to displacement of the body

$$= g\rho V (\zeta \cos \theta + \xi \sin \theta - \zeta) = -\frac{1}{2}g\rho \theta^2 V \zeta + g\rho\theta V \xi,$$

therefore the total gain in potential energy is

$$\begin{aligned} E &= \frac{1}{2}g\rho\theta^2 \iint \left(x^2 - \frac{z^2}{2}\right) dx dy + \frac{1}{2}g\rho\theta^2 V \zeta \\ &= \frac{1}{2}g\rho\theta^2 (Ak^2 - V\bar{z} + V\zeta) \\ &= \frac{1}{2}g\rho\theta^2 (Ak^2 - V.HG) \dots\dots\dots(1), \end{aligned}$$

where  $A$  is the area of the surface section of the body and  $k$  is its radius of gyration about  $Oy$ .

From this it follows that the equilibrium is stable if  $Ak^2 > V.HG$ , and that the restorative couple is

$$\frac{dE}{d\theta} = g\rho\theta (Ak^2 - V.HG).$$

**95.** If the volume of liquid displaced be constant, and if the vertical through the centre of buoyancy in the displaced position intersects  $HG$  in  $M$ , then  $M$  is called a **metacentre**\*.

The analytical conditions for the existence of a metacentre are

$$\iint (z + x\theta) dx dy = \iint z dx dy, \quad \text{or} \quad \iint x dx dy = 0,$$

i.e. the axis of rotation  $Oy$  must pass through the centroid of the surface section (cf. Art. 52); and, since the new centre of buoyancy must be in the plane  $xOz$ ,

$$\iint y (z + x\theta) dx dy = 0;$$

but  $\iint yz dx dy = 0, \quad \therefore \iint xy dx dy = 0,$

i.e. the axis  $Oy$  must be a principal axis of the surface section.

\* Some writers use the word *metacentre* in a less restricted sense, taking it to be the point where the shortest distance between two consecutive normals to the surface of buoyancy intersects one of these normals. Cf. Appell, *Traité de Mécanique Rationnelle*, Tome III. p. 197.

In this case it is evident that if  $M$  is above  $G$  the couple formed by the weight of the body and the resultant liquid pressure tends to restore equilibrium and

$$\begin{aligned} &= g\rho V \cdot GM \cdot \theta \\ &= g\rho V(HM - HG) \theta, \end{aligned}$$

$\therefore HM = Ak^2/V$ ; and the equilibrium is stable or unstable according as  $M$  is above or below  $G$ .

Since the metacentre is the intersection of consecutive normals to the surface of buoyancy, there are, in general, two metacentres, corresponding to displacements in the two planes of principal curvature of the surface at  $H$ ; and  $HM$  is a principal radius of curvature of the surface of buoyancy.

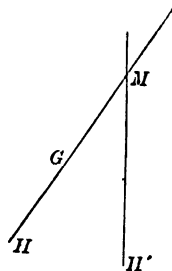

**96. Bodies under constraint.** The case of a floating body constrained to turn about a fixed horizontal axis may be treated as in Art. (94).

If  $Oy$  is the fixed axis, and  $(\xi, \eta, \zeta)$  (*i.e.*  $x, y, z$ ) are the co-ordinates of  $G$  and  $H$  respectively, and  $W$  is the weight of the body, the condition of equilibrium is

$$g\rho Vx = W\xi.$$

And if the fixed axis of rotation is in the plane of flotation and the body is turned through a small angle  $\theta$ , the increase in potential energy due to the displaced liquid

$$= \frac{1}{2}g\rho\theta^2(Ak^2 - Vz) + g\rho\theta Vx,$$

and the loss due to the displacement of the body

$$= -\frac{1}{2}\theta^2 W\xi + \theta W\xi,$$

therefore the total gain in potential energy

$$= \frac{1}{2}g\rho\theta^2(Ak^2 - Vz) + \frac{1}{2}\theta^2 W\xi.$$

And the equilibrium is stable provided

$$Ak^2 > Vz - W\xi/g\rho.$$

**97.** If the axis of rotation  $O'$  be at a depth  $h$ , and we take its projection on the plane of flotation for  $Oy$  and suppose the axes to move with the body as before,  $O$  descends a distance  $\frac{1}{2}h\theta^2$ , and the increase of potential energy due to the displaced liquid

$$= \frac{1}{2}g\rho \iint (z + x\theta + \frac{1}{2}h\theta^2)^2 (1 - \frac{1}{2}\theta^2) dx dy - \frac{1}{2}g\rho \iint z^2 dx dy$$

$$= \frac{1}{2}g\rho \iint (x^2\theta^2 - \frac{1}{2}z^2\theta^2 + zh\theta^2 + 2xz\theta) dx dy$$

$$= \frac{1}{2}g\rho\theta^2(Ak^2 - Vz + Vh) + g\rho\theta V\bar{x},$$

and the work done by gravity on the body

$$= W \left\{ \zeta \left( 1 - \frac{1}{2} \theta^2 \right) + \xi \theta + \frac{1}{2} h \theta^2 - \zeta \right\},$$

therefore the total external work done

$$= \frac{1}{2} g \rho \theta^2 \{ A k^2 - V(\bar{z} - h) \} + \frac{1}{2} W \theta^2 (\zeta - h),$$

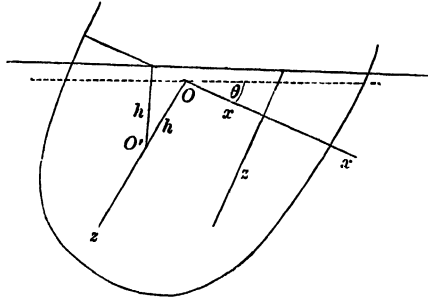

where  $A$  is the area of the surface section and  $k$  is its radius of gyration about the projection of the fixed axis on the plane of flotation.

The condition for stability is

$$A k^2 > V(\bar{z} - h) - \frac{W}{g\rho} (\zeta - h).$$

**98. Heterogeneous Liquid.** *To find the work done in turning a body, floating in heterogeneous liquid, round any line in the plane of flotation.*

Take axes as in Art. (94) and, using the same notation, we may write  $\rho = f'(z)$ ; but  $dp = g\rho dz$ ,

$$\therefore p = g \{ f(z) - f(0) \}.$$

From Art. (93) the work done in inserting the body in the liquid in any position is  $\iiint p dx dy dz$ , where the integration extends to the volume immersed. When the body has been turned through a small angle  $\theta$  this becomes

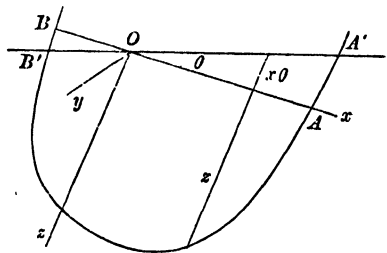

$$\iiint p' dx dy dz + \iiint_{-x\theta}^0 p' dx dy dz,$$

where  $p'$  is the new pressure at the element  $dx dy dz$ , and the first integral is over the same range as before, while the second refers to the wedges  $AOA'$ ,  $BOB'$ .

$$\begin{aligned} \text{Now } p' &= g \{ f(z - \frac{1}{2}z\theta^2 + x\theta) - f(0) \} \\ &= p + g(x\theta - \frac{1}{2}z\theta^2)f'(z) + \frac{1}{2}gx^2\theta^2 f''(z); \\ \therefore \iiint p' dx dy dz &= \iiint \left\{ p + g\theta x\rho - \frac{1}{2}g\theta^2 \left( z\rho - x^2 \frac{d\rho}{dz} \right) \right\} dx dy dz. \end{aligned}$$

In the integral pertaining to the wedges  $z$  is everywhere  $\neq x\theta$ , and, retaining only the first power of  $\theta$  in the above expression for  $p'$ , we have

$$\begin{aligned} p' &= g \{ f(z) - f(0) + x\theta f'(z) \} \\ &= g \{ z f'(0) + x\theta f'(z) \}, \\ \therefore \int_{-x\theta}^0 p' dz &= g \left\{ -\frac{1}{2}x^2\theta^2 f'(0) + x\theta f(0) - x\theta f(-x\theta) \right\} \\ &= \frac{1}{2}gx^2\theta^2 f'(0) = \frac{1}{2}g\rho_0 x^2\theta^2. \end{aligned}$$

Therefore the work done against the pressures of the liquid in making the displacement, being the increase in potential energy,

$$\begin{aligned} &= g\theta \iiint x\rho dx dy dz - \frac{1}{2}g\theta^2 \iiint \left( z\rho - x^2 \frac{d\rho}{dz} \right) dx dy dz \\ &\quad + \frac{1}{2}g\rho_0\theta^2 \iint x^2 dx dy, \end{aligned}$$

but the weight of the body does work

$$W\{\xi(1 - \frac{1}{2}\theta^2) + \xi\theta - \xi\},$$

where, as before,  $(\xi, 0, \zeta)$  are co-ordinates of  $G$  the centre of mass of the body, and

$$W\xi = W.v = g\iiint x\rho dx dy dz,$$

$\therefore$  the total external work done in making the displacement

$$= \frac{1}{2}\theta^2 \left\{ g\rho_0 \iint x^2 dx dy + g \iiint x^2 \frac{d\rho}{dz} dx dy dz - W(\bar{z} - \xi) \right\} \dots (1).$$

If  $A$  is the area of the section at depth  $z$  and  $k$  its radius of gyration about its intersection with the plane  $yOz$ , we get, by integrating the second integral by parts,

$$\frac{1}{2}\theta^2 \left\{ g\rho_0 A_0 k_0^2 + \left[ g\rho A k^2 \right]_0^1 - g \int_0^1 \rho \frac{d}{dz} (A k^2) dz - W.HG \right\},$$

where the integration with regard to  $z$  is from the water line to the lowest level, or changing the order of integration the expression for the work done becomes

$$\frac{1}{2}\theta^2 \left\{ g\rho_1 A_1 k_1^2 + g \int_{\text{lowest level}}^{\text{water line}} \rho \frac{d}{dz} (A k^2) dz - W.HG \right\},$$

where  $\rho_1, A_1, k_1$  apply to the lowest horizontal section of the body, and  $A_1 = 0$  unless the body has a flat bottom.

The equilibrium is clearly stable if this expression is positive.

**99.** For a metacentre to exist, the mass of liquid displaced must be constant, and the vertical through the centre of buoyancy must intersect  $HG$ .

The condition of constant mass is expressed by

$$\iiint f'(z + x\theta) dx dy dz + \iint \rho_0 x\theta dx dy = \iiint f'(z) dx dy dz,$$

or 
$$\iiint \left( \rho + x\theta \frac{d\rho}{dz} \right) dx dy dz + \rho_0 \theta \iint x dx dy = \iiint \rho dx dy dz,$$

or 
$$\iiint x \frac{d\rho}{dz} dx dy dz + \rho_0 \iint x dx dy = 0.$$

And the second condition requires that

$$\iiint f'(z + x\theta) y dx dy dz + \rho_0 \theta \iint xy dx dy = 0,$$

but 
$$\iiint f'(z) y dx dy dz = 0;$$

$\therefore$  the condition becomes

$$\iiint xy \frac{d\rho}{dz} dx dy dz + \rho_0 \iint xy dx dy = 0.$$

Both conditions are satisfied if there is symmetry about the axis of  $z$ , or if all horizontal lines in the plane  $yOz$  are principal axes through the centroids of the corresponding horizontal sections, so that at all levels

$$\iint xy dx dy = 0 \text{ and } \iint x dx dy = 0.$$

When these conditions are satisfied, if  $M$  is the metacentre the restorative couple

$$W.GM.\theta \text{ or } W(HM - HG)\theta \\ = \theta \left\{ g\rho_1 A_1 k_1^2 + g \int \rho \frac{d}{dz} (Ak^2) dz - W.HG \right\};$$

$$\therefore W.HM = g \left\{ \rho_1 A_1 k_1^2 + \int \rho \frac{d}{dz} (Ak^2) dz \right\},$$

where the integration is from the lowest level to the surface section.

**100.** Since the result (1) of Art. (93) is true, whether the body bulges out beneath the liquid or not, the results of the two preceding articles are also true in either case, and since the expression (1) of Art. (94) is only a special case of (1) of Art. (98),

we infer that the results obtained for a homogeneous liquid are also true whether the body bulges out beneath the liquid or not.

**101. Body completely immersed.** *A body floats completely immersed in heterogeneous liquid, to find the work done in turning it through a small angle about any horizontal axis.*

Take  $Oy$  for axis of rotation as before, and  $Ox, Oz$  fixed in the body, and let  $h$  be the depth of  $Oy$ , and  $\rho = f'$  (depth) so that

$$p = g \{f(z+h) - f(0)\}$$

in the equilibrium position, and in the displaced position

$$\begin{aligned} p' &= g \{f(z - \frac{1}{2}z\theta^2 + h + x\theta) - f(0)\} \\ &= p + g(x\theta - \frac{1}{2}z\theta^2)\rho + \frac{1}{2}g.c^2\theta^2 \frac{d\rho}{dz}, \end{aligned}$$

and the work done against the pressures of the liquid in turning the body through a small angle  $\theta$  round  $Oy$

$$\begin{aligned} &= \iiint (\rho' - \rho) dx dy dz && \text{[Art. (93)]} \\ &= g\theta \iiint x\rho dx dy dz + \frac{1}{2}g\theta^2 \iiint \left(x^2 \frac{d\rho}{dz} - \rho z\right) dx dy dz, \end{aligned}$$

where the integration extends to the whole amount of liquid displaced. But the work done by the weight of the body in the displacement

$$= W \left\{ \zeta(1 - \frac{1}{2}\theta^2) + \xi\theta - \zeta \right\},$$

where, as before,  $(\xi, 0, \zeta)$  are co-ordinates of  $G$  the centre of mass of the body, and

$$W\xi = W\bar{x} = \iiint x\rho dx dy dz.$$

Therefore the total work done in the displacement

$$\begin{aligned} &= \frac{1}{2}\theta^2 \left\{ g \iiint x^2 \frac{d\rho}{dz} dx dy dz - W(\bar{z} - \zeta) \right\} \\ &= \frac{1}{2}\theta^2 \left\{ g \iiint x^2 \frac{d\rho}{dz} dx dy dz - W.HG \right\} \\ &= \frac{1}{2}\theta^2 \left\{ g \int Ak^2 \frac{d\rho}{dz} dz - W.HG \right\}, \end{aligned}$$

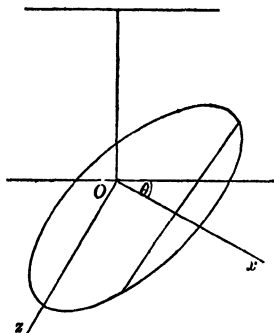

where the integration is from the highest to the lowest point of the body.

102. The equilibrium is stable if the above expression is positive; and the position of a metacentre, when one exists, can be determined as before. Thus if  $M$  is the metacentre the restorative couple

$$W \cdot GM \cdot \theta \text{ or } W (HM - HG) \theta = \left\{ g \int A k^2 \frac{d\rho}{dz} dz - W \cdot HG \right\} \theta;$$

$$\therefore W \cdot HM = g \int A k^2 \frac{d\rho}{dz} dz,$$

$$\text{or } W \cdot HM = g \left\{ A_1 k_1^2 \rho_1 - A_0 k_0^2 \rho_0 - \int \rho \frac{d}{dz} (A k^2) dz \right\},$$

where  $A_1$ ,  $k_1$ ,  $\rho_1$  and  $A_0$ ,  $k_0$ ,  $\rho_0$  refer to the lowest and highest horizontal sections of the body, and the integration is from the highest to the lowest point.

If the solid is not flat at either its highest or lowest point, we may write

$$HM = \int \rho \frac{d}{dz} (A k^2) dz / \text{Mass},$$

where the integration is from the lowest to the highest point of the body.

103. *Potential energy stored up by the immersion of a solid in a liquid.*

If a solid body be immersed in a vessel containing liquid, work is done, and therefore potential energy is gained by the elevation of the centre of gravity of the liquid.

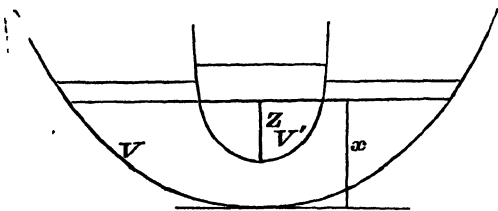

Let  $x$  be the depth of liquid,  $z$  the depth of immersion of the solid,  $X$  and  $Z$  the corresponding areal sections of the vessel and the solid,  $V$  the volume of liquid, and  $V'$  of the immersed portion of the solid.

Then, 
$$V\bar{x} = \int_0^x X' x' dx' - \int_0^z Z' (x - z + z') dz',$$

and the increase of potential energy is the variation of the expression  $g\rho V\bar{x}$ , due to an increase  $\delta x$  in  $x$ .

Taking  $g\rho = 1$ , this variation

$$= X\delta x - (\delta x - \delta z)V' - (x - z)Z\delta z - Zz\delta z,$$

and, observing that

$$V = \int_0^x X' dx' - \int_0^z Z' dz',$$

and therefore that

$$X\delta x = Z\delta z,$$

the variation =  $V'(\delta z - \delta x)$ .

This result can of course be obtained at once by observing that  $V'$  is equal to the resultant vertical pressure on the solid, and that  $\delta z - \delta x$  is the descent of the solid due to the ascent  $\delta x$  of the liquid.

**104.** *Potential energy where a body floats in liquid contained in a cylindrical vessel.*

Take the zero of reckoning to be the undisturbed level of the liquid in the vessel before the body is immersed. Let  $B$  be the cross-section of the vessel and  $S$  the water-section of the body when floating. Let  $V_0$  be the volume immersed in the equilibrium position; taking  $g\rho = 1$ ,  $V_0$  also denotes the weight of the body. Let  $V$  be the volume immersed in any other position. In this latter position the level of the water is raised a height  $V/B$ , so that if the centre of buoyancy is at a depth  $p$  below the zero level, a weight  $V$  has been raised a height  $p + V/2B$  and the work done is  $Vp + V^2/2B$ . Hence if  $q$  denote the height of the centre of gravity of the body above the zero level, the whole potential energy is

$$V_0q + Vp + V^2/2B.$$

Now let  $V = V_0 + v$ , and let  $p_0$  be the depth of the centroid of the volume  $V_0$  of the body in the displaced position, so that  $Vp = V_0p_0 + v\xi$  where, provided that  $v$  is small,  $\xi = v/2S - V/B$ .

Then the potential energy is

$$\begin{aligned} & V_0(q + p_0) + v\left(\frac{v}{2S} - \frac{V}{B}\right) + \frac{V^2}{2B} \\ &= V_0(q + p_0) + v\left(\frac{v}{2S} - \frac{V_0 + v}{B}\right) + \frac{(V_0 + v)^2}{2B} \\ &= V_0\xi + \frac{1}{2}v^2\left(\frac{1}{S} - \frac{1}{B}\right) + \text{constant}, \end{aligned}$$

where  $\zeta$  denotes the vertical distance between the centre of buoyancy and the centre of gravity.

**105. EXAMPLE.** *A cylinder floating in a cylinder.*

Take the origin  $O$  at the centroid of the base of the floating cylinder, which is of area  $A$ . Let the plane of the surface of the liquid be

$$lx + my + nz = p,$$

where  $l, m, n$  are direction cosines of the upward vertical.

Then  $V_0 = A\rho/n$ , and the projection on the upward vertical of the line  $OH_0$ , where  $H_0$  is the equilibrium position of the centre of buoyancy, is

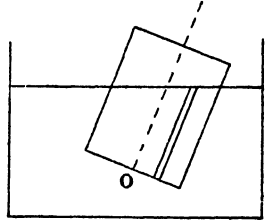

$$\begin{aligned} \frac{1}{V_0} \iint (lx + my + \frac{1}{2}nz) z dx dy &= \frac{1}{V_0} \iint \frac{1}{2}(\rho + lx + my) \frac{1}{n}(\rho - lx - my) dx dy \\ &= \frac{1}{2nV_0} \iint \{ \rho^2 - (lx + my)^2 \} dx dy \\ &= \frac{1}{2nV_0} \{ A\rho^2 - (a^2 + \beta m^2 + 2\gamma lm) \}; \end{aligned}$$

where  $a = \iint x^2 dx dy$ ,  $\beta = \iint y^2 dx dy$ ,  $\gamma = \iint xy dx dy$  integrated over the cross-section.

Also, if  $a, b, c$  are the co-ordinates of the centre of gravity  $G$  of the body, we see that

$$V_0 \zeta = V_0 (la + mb + nc) - \frac{1}{2n} \{ A\rho^2 - (a^2 + \beta m^2 + 2\gamma lm) \}$$

and  $S = A/n$ , so that the potential energy is

$$\frac{1}{2} v^2 \left( \frac{n}{A} - \frac{1}{B} \right) + V_0 (la + mb + nc) + \frac{1}{2n} (a^2 + \beta m^2 + 2\gamma lm) - \frac{1}{2} n V_0^2 + \text{const.}$$

Suppose, for example, that  $a = b = 0$ , so that  $G$  is on the line of centroids  $Oz$ , and write  $V_0 = Ah$  so that  $h$  is the draught in the vertical position; then the potential energy is

$$\frac{1}{2} v^2 \left( \frac{n}{A} - \frac{1}{B} \right) + \frac{1}{2} n Ah (2c - h) + \frac{1}{2n} (a^2 + \beta m^2 + 2\gamma lm).$$

In the case in which the cylinder is nearly vertical we put  $n = 1 - \frac{1}{2}(l^2 + m^2)$  approximately, and the coefficients of  $l^2$  and  $m^2$  become

$$\frac{1}{2} \{ a - \frac{1}{2} Ah (2c - h) \} \text{ and } \frac{1}{2} \{ \beta - \frac{1}{2} Ah (2c - h) \},$$

so that for stability we must have  $\frac{1}{2} Ah (2c - h)$  less than the least moment of inertia of the section.

If, further, the section is a circle or any form for which  $a = \beta$ ,  $\gamma = 0$ , then the potential energy in a position in which the axis makes an angle  $\theta$  with the vertical is

$$\frac{1}{2} v^2 \left( \frac{\cos \theta}{A} - \frac{1}{B} \right) + \frac{1}{2} \cos \theta Ah (2c - h) + \frac{1}{2} a \frac{\sin^2 \theta}{\cos \theta}.$$

Taking the volume displaced as constant, we put  $r=0$ , so that for equilibrium in an oblique position we must have

$$-Ah(2c-h) + a(2 + \tan^2 \theta) = 0,$$

which gives a real value for  $\theta$ , when

$$\frac{1}{2}Ah(2c-h) > a,$$

i.e. when the vertical position is unstable.

EXAMPLES.

1. An inverted vessel formed of a substance which is heavier than water contains enough air to make it float; prove that, if it be pushed down through a certain space, it will be in a position of equilibrium which for vertical displacement will be unstable.

✓ 2. If a solid paraboloid, bounded by a plane perpendicular to its axis, float with its axis vertical and vertex immersed, the height of the metacentre above the centre of gravity of the displaced liquid is equal to half the latus rectum.

✓ 3. A cone, whose vertical angle is  $60^\circ$ , floats in water with its axis vertical and vertex downwards; shew that its metacentre lies in the plane of flotation; and that its equilibrium will be stable provided its specific gravity  $> \frac{1}{2}$ .

✓ 4. An isosceles wedge floats with its base horizontal, and its edge immersed; shew that the equilibrium is stable for displacement in a plane perpendicular to the edge, if the ratio of the density of the wedge to that of the fluid is greater than the ratio  $\cos^4 a : 1$ ;  $2a$  being the angle of the wedge.

5. A closed cylindrical vessel, quarter-filled with ice, is placed floating in water with its axis vertical; the weight of the vessel is one-fourth of the weight of the water which it can contain; examine the nature of the equilibrium before and after the ice melts, neglecting the change of volume consequent on the change of temperature.

✓ 6. A solid in the shape of a double cone bounded by two equal circular ends floats in a liquid of twice its density with its axis horizontal: prove that the equilibrium is stable or unstable according as the semivertical angle is less or greater than  $60^\circ$ .

✓ 7. The cross section of a cylindrical ship is two equal arcs of equal parabolas of latus rectum  $l$  which touch at the keel, the common vertex of the two parabolas, so that the sides of the ship are concave to the water. The ship is floating upright with its keel at a depth  $h$ . Prove that the height of the metacentre above the keel is

$$h \left( \frac{3}{4} + \frac{h^2}{7l} \right).$$

✓ 8. Find a solid of revolution such that, when a segment of it is immersed in liquid, the distance between the centre of buoyancy and the metacentre may be constant, whatever be the height of the segment.

9. Water rests upon mercury, and a cone is too heavy to rest without its vertex penetrating the mercury; find the density of the cone that the equilibrium may be stable.

10. If the floating solid be a cylinder, with its axis vertical, the ratio of whose specific gravity to that of the fluid is  $\sigma$ , prove that the equilibrium will be stable, if the ratio of the radius of the base to the height be greater than  $\{2\sigma(1-\sigma)\}^{\frac{1}{2}}$ .

11. A paraboloidal uniform shell floats with its axis vertical and  $\frac{3}{4}$  immersed in water when filled to a depth  $\frac{1}{4}$  of its axis with a fluid of density 5. Shew that the equilibrium is stable.

12. A vessel in the form of a paraboloid of revolution contains water, and rests with its vertex on the highest point of a fixed rough sphere; find the condition that the equilibrium may be stable.

13. If a cylindrical shell without weight contain liquid and float in another liquid, shew that the equilibrium will be stable, unless the ratio of the density of the internal to the external liquid is less than unity, and greater than half the duplicate ratio of the radius of the cylinder to the depth of the internal liquid.

14. A hemispherical shell, containing liquid, is placed on the vertex of a fixed rough sphere of twice its diameter; prove that the equilibrium will be stable or unstable, according as the weight of the shell is greater or less than twice the weight of the liquid.

15. A solid of revolution floats with its vertex downwards, determine its form when the position of the metacentre is independent of the density of the liquid.

16. A conical shell, vertex downwards, floats in unstable equilibrium; how much water must be poured in to make the equilibrium stable?

✓ 17. A solid cone is placed in a liquid with its axis vertical, and with its vertex downwards and resting on the base of the vessel containing the liquid. If the depth of the liquid be half the height of the cone, and its density four times the density of the cone, prove that the equilibrium will be stable if the vertical angle of the cone exceeds  $120^\circ$ .

Replacing the solid cone by a thin conical shell of the same height, of vertical angle  $60^\circ$ , containing liquid, up to the level of the middle point of its axis, of half the density of the liquid outside, prove that the equilibrium will be stable if the weight of the shell be less than three-fourths of the weight of the liquid inside.

18. A cylindrical vessel, the weight of which may be neglected, contains water, and the vessel is placed on the vertex of a fixed rough sphere with the centre of its base in contact with the sphere. Find the condition of stability for infinitesimal displacements, and prove that, if the equilibrium be neutral for such displacements, it will be unstable for small finite displacements.

19. Find the form of a solid of revolution floating with its axis vertical, and such that the distances of the metacentre and the centre of buoyancy from the lowest end of the solid may be in a constant ratio whatever be the density of the liquid.

20. A semicircular cylinder rests with its axis vertical in a liquid of twice its own density; if it be moveable about the line of intersection of its vertical plane face with the surface, find the condition of stability.

21. A right circular cone floats with its axis horizontal in a liquid the density of which is double that of the cone, the vertex being attached to a fixed point in the surface of the liquid; prove that for stability the vertical angle must be less than  $120^\circ$ .

✓ 22. A cylindrical vessel is moveable about a horizontal axis passing through its centre of gravity, and is placed so as to have its axis vertical; if water be poured in, shew that the equilibrium is at first unstable; and find the condition which must be satisfied, in order that it may be possible to make the equilibrium stable by pouring in enough water.

23. A thin conical vessel of given weight is moveable about a diameter of its base, which is horizontal, and is partly filled with a heavy fluid; shew that the equilibrium is always stable if the semivertical angle of the cone is  $< 30^\circ$ ; and if it be greater than this, determine when the equilibrium is stable or unstable.

24. Water is contained in a vessel having a horizontal base, and a paraboloid whose specific gravity is four-ninths that of water, and the length of whose axis is to the latus rectum as nine to eight, is supported partly by the fluid and partly by the base on which the vertex rests; find the least depth of the fluid for which the equilibrium is stable.

25. A paraboloidal cup, the weight of which is  $W$ , standing on a horizontal table, contains a quantity of water, the weight of which is  $nW$ ; if  $h$  be the height of the centre of gravity of the cup and the contained water, the equilibrium will be stable provided the latus rectum of the parabola be  

$$> 2(n+1)h.$$

26. A solid of revolution floats with its axis vertical, and is sunk to different depths by placing weights at a fixed point on its axis. Find the form of the solid that the equilibrium may always be neutral.

27. A solid cone whose axis is vertical and vertex downwards is moveable about an axis coincident with a generating line; to what depth must the system be immersed in water, in order that the equilibrium of the cone may be stable?

28. A solid of cork bounded by the surface generated by the revolution of a quadrant of an ellipse about the axis major sinks in mercury up to the focus. If the equilibrium be neutral for small angular displacements, prove that

$$2e^4 + 4e^3 + 2e^2 - e - 2 = 0.$$

29. A solid cone, whose vertical angle  $2a$  is less than  $60^\circ$ , is moveable about a smooth straight wire through its centre of gravity perpendicular to its axis. If the wire is held in the surface of a liquid, prove that the cone will be in a position of stable equilibrium when its axis is inclined to the horizon at the angle  $\sin^{-1}(2 \sin a)$ .

✕ 30. Prove that the work done in turning a floating body through a small angle  $\theta$  round its centre of gravity is

$$\frac{1}{2} g \rho (Ak^2 + Ab^2 - c^2) \theta^2,$$

where  $c$  is the distance between the centres of gravity of the body and the liquid displaced, and  $b$  is the horizontal distance between the centre of gravity of the body and that of the area of the plane of flotation.

31. A paraboloidal cup, whose latus rectum is  $4a$  and whose centre of mass is at a distance from the vertex equal to  $2a$ , floats in two liquids of densities  $\sigma$  and  $\rho$  ( $\sigma > \rho$ ); prove that the work required to turn the body through a small angle  $\theta$  about a horizontal axis is

$$\frac{1}{3} \pi a g \theta^2 \{h^3 (\sigma - \rho) + (h+h')^3 \rho\},$$

where  $h, h'$  are the lengths of the axis immersed in the fluids.

32. A right-angled isosceles triangle floats vertex downwards in a fluid with its base horizontal and  $\frac{1}{4}$  of its area immersed, so that its centre of gravity and metacentre coincide. Determine whether the equilibrium is really stable or unstable.

33. A solid in the form of a paraboloid of revolution floats with its axis vertical; if the centre of inertia coincides with the metacentre, prove that the equilibrium is stable.

34. The solid formed by a portion of  $cy^2 = z(a^2 - x^2)$  cut off by a plane parallel to that of  $xy$  floats in a fluid of  $n$  times its density; prove that, if it is in neutral equilibrium for small angular displacements in any vertical plane,

$$n^{\frac{2}{3}} = 1 + \frac{5}{8} \frac{a^2}{c^2}.$$

35. An isosceles triangular lamina  $ABC$  floats with its base  $AB$  horizontal, and above the surface, in a liquid, the density of which varies as the depth: if  $h$  be the depth of  $C$  below the surface, the height of the metacentre above  $C$  is

$$\frac{1}{2} h \sec^2 \frac{C}{2}.$$

36. An elliptic lamina floats half immersed, with its transverse axis ( $2a$ ) vertical, in a liquid, the density of which varies as the square of the depth; prove that the depth of the metacentre is  $32ae^2/15\pi$ ,  $e$  being the eccentricity.

37. A right circular cylinder of radius  $a$  rests in a liquid with its axis vertical and a length  $c$  immersed. The density at a depth  $z$  being  $\phi(z)$ , shew that the depth of the metacentre is

$$\frac{\int_0^c z \phi(z) dz - \frac{1}{2} a^2 \phi(c)}{\int_0^c \phi(z) dz}.$$

38. A paraboloid of revolution floats with its axis vertical and vertex downwards in a liquid, the density of which varies as the depth; the equilibrium will be stable or unstable, according as  $4c$  is less or greater than  $3(m+a)$ , where  $c$  is the length of the axis,  $a$  the length immersed, and  $m$  the latus rectum of the generating parabola.

39. An oblate spheroid floats half immersed, with its axis vertical, in a liquid, the density of which varies as the square of the depth; prove that the height of the metacentre above the surface is

$$\frac{5}{8} \frac{a^2 - b^2}{b}.$$

40. A solid paraboloid of revolution floats with its axis vertical, vertex downwards, and focus in the surface of a liquid, the density of which at the depth  $z$  is  $\mu(a+z)$ ,  $4a$  being the latus rectum of the generating parabola; prove that the distance of the metacentre from the vertex is  $\frac{21}{4}a$ .

41. A homogeneous cone floats with its vertex downwards in a liquid whose density varies as the square of the depth; if the density of the cone be equal to that of the liquid at a depth equal to a fifth of the height of the cone, the vertical angle, when the equilibrium is neutral, is given by the equation

$$\cos^2 \alpha = \frac{2}{3} \left( \frac{2}{3} \right)^{\frac{1}{2}}.$$

42. A solid paraboloid of height  $h$  and latus rectum  $4a$  is in equilibrium in a vertical position, with its vertex downwards, and is moveable about its vertex, which is fixed at a given depth  $c$  below the surface of a liquid, the density of which varies as the depth; prove that the equilibrium is stable if the ratio of the density of the paraboloid to the density of the liquid at the depth of its vertex is less than the ratio of  $c^3 + 4ac^2$  to  $4h^3$ .

43. A right circular solid cone of semivertical angle  $a$  floats, wholly immersed, with its vertex upwards and axis vertical, in a liquid the density of which varies as the depth. If  $h$  is the height of the cone, and  $b$  the depth of its vertex below the surface, the distance of the metacentre from the vertex is equal to

$$\frac{3}{5}h \cdot \frac{5b + 4h - h \tan^2 a}{4b + 3h}$$

44. A cylindrical tub of sheet iron of uniform thickness, of radius  $a$  feet and weight  $w$  pounds, floats upright in water; show that its centre of gravity cannot be higher above the lower end than

$$\frac{w}{393a^2} + \frac{49a^4}{w}$$

Prove also that, whatever be its weight, its metacentre is always more than  $\cdot 7a$  feet above the lower end.

45. A cylindrical cup is made of thin uniform sheet-metal; the cup has a circular section, a flat base and an open top; its length is  $4\frac{1}{2}$  times the radius of the base, and the weight of water which would fill the cup is  $W$ . Prove that the cup cannot float in water in stable equilibrium with its generators vertical, if its weight is between  $(\cdot 029)W$  and  $(\cdot 871)W$ .

If the weight of the cup is  $\frac{2}{3}W$ , it can be steadied by pouring in water, so as to float with its generators vertical, provided that the weight of the water poured in lies between  $\frac{1}{4}W$  and  $\frac{2}{3}W$ .

46. A plate of density  $\sigma$ , in the form of a parabola, of latus rectum  $4a$ , bounded by a double ordinate at a distance  $h$  from its vertex, floats in a liquid of density  $\rho$  with its plane vertical; shew that if

$$3h(1 - \kappa) > 10a,$$

and

$$h(1 - \kappa) + 5a > [5\kappa h \{3h(1 - \kappa) - 10a\}]^{\frac{1}{2}},$$

there are two positions of stable equilibrium, in which the axis makes with the vertical an angle

$$\tan^{-1} \left\{ \frac{3h}{5a} (1 - \kappa) - 2 \right\}^{\frac{1}{2}},$$

where  $\kappa^2 = \sigma^2/\rho^2$ .

47. A body floats freely in two liquids of densities  $\rho$  and  $\rho + \sigma$ . The areas of the section of the body by the free surface and the common surface are  $a$  and  $a'$  and their centres of gravity are  $C$  and  $C'$ . Prove that, for a slight displacement, the mass of the fluid displaced will be the same, if the axis of rotation lie in a vertical plane dividing  $CC'$  in the ratio of  $\sigma/a : \rho/a'$  or  $\sigma(1/a - 1/A) : \rho(1/a' - 1/A')$ , according as the liquids are infinite or enclosed in a vessel the areas of whose sections by the planes of  $a$  and  $a'$  are  $A$  and  $A'$ .

48. A twin steamer is formed of two equal and similar ships united alongside one another and similarly loaded. Shew that, if  $d$  is the height of the metacentre above the centre of gravity in the case of the separate ships for rolling, the height in the twin ship is  $d + b^2A/V$ , where  $A$  is the area of the plane of flotation,  $V$  the volume immersed of either, and  $2b$  the distance between the medial planes.

49. Prove that the equilibrium of a prismatic body with vertical sides near the water-line, which is so loaded that its centre of gravity coincides with its metacentre for displacement by rotation about a line parallel to its edges, is stable.

50. A frustum of a cone, semivertical angle  $\alpha$ , floats in a liquid of twice its own density. Shew that it can float with its axis inclined to the vertical, and the end of greater diameter outside the fluid, provided

$$\cos \alpha > (R^3 + r^3)^{2/3} / 2^{1/3} (R^2 + r^2)^{1/2},$$

where  $R, r$  are the radii of the ends.

51. A closed frustum of a thin conical shell, whose weight may be neglected, floats in homogeneous fluid and contains another heavier homogeneous fluid. Shew that, whichever end of the frustum be immersed, the condition of stability when the axis is vertical is that

$$l^2 < r^4 (r_1^2 + r_1 r_2 + r_2^2) / r^3 (r_1 + r_2) (r_1^2 + r_2^2) - r_1^3 r_2^3,$$

where  $h$  is the length of the axis immersed and  $l$  of the part of a generator immersed,  $r$  is the radius of the immersed end of the frustum and  $r_1$  and  $r_2$  are the radii of the internal and external water-lines.

52. A solid cube floats in liquid with a diagonal vertical. Shew that for all angular displacements the equilibrium will be stable or unstable, according as the section of the cube by the plane of flotation is a hexagon, or a triangle.

53. An ellipsoid floats in a liquid of double its specific gravity. A small couple in a vertical plane acts upon it and keeps it in a slightly displaced position; prove that the intersection of the plane of the couple with the surface of the fluid and the axis round which the ellipsoid has revolved, are conjugate with respect to the focal conic in the plane of flotation.

54. Shew that, if the position of a floating body be unstable, the centre of gravity being over both metacentres, the fixing of a line in the body in the plane of the water surface gives a stable position for rotation about the line if the line lie outside a definite ellipse.

55. If a solid homogeneous cone float in stable equilibrium with its axis vertical and base unimmersed in a fluid of which the density varies as the  $n$ th power of the depth, prove that the semivertical angle must be

$$> \cos^{-2} \frac{2}{\sqrt{4+n}} \sqrt{\frac{h}{H}},$$

where  $H$  is the height of the cone and  $h$  is the length of the axis immersed.

56. A heavy homogeneous cube is completely immersed with two faces horizontal in a fluid whose density =  $\kappa$  times the cube of the depth. Prove that the metacentric height is  $\frac{\kappa a^7}{120M}$ , where  $M$  is the mass and  $a$  the length of an edge of the cube.

57. A thin vessel in the form of a right circular cone, whose weight is negligible, floats with axis vertical in liquid whose density is  $\mu(a+z)$ ,  $z$  being the depth below the surface and  $h$  the length of the axis immersed. Prove that, if it contain liquid of density  $\mu' \left( a + \frac{h}{4} \right)$ , the equilibrium will be stable provided

$$\frac{4}{5} \left( \frac{\mu'}{\mu} \right)^{1/2} > \frac{4a+h}{5a+h}.$$

58. A long portion of a homogeneous heavy parabolic cylinder, bounded by two planes perpendicular to the generators and one perpendicular to the axis of the generating parabola, rests with its axial plane vertical, and lowest generator in contact with the horizontal rough base of a vessel, into which liquid is poured, which settles so that the density varies as the  $n$ th power of the depth. The depth of the liquid is  $h$ ; the height of the solid is  $k$ , ( $> h$ ); and  $4a$  is the latus rectum of the generating parabola. Supposing that the condition of flotation is not reached, shew that for stability the ratio of the density of the solid to that of the lowest stratum of liquid must be less than

$$\frac{45}{8} \frac{\Gamma(n+1)}{\Gamma\left(\frac{2n+7}{2}\right)} \sqrt{\pi} \left(\frac{h}{k}\right)^{\frac{3}{2}} \frac{h}{3k-10a},$$

while

$$15h > (2n+5)(3k-10a).$$

59. A uniform solid right circular cone of density  $\sigma$  and vertical angle  $2a$  floats with its vertex downwards and its base above the surface in a fluid whose density varies as the  $n$ th power of the depth, and is  $\rho$  at a depth equal to the height of the cone. Shew that in the vertical position the equilibrium is stable provided that

$$(1+n) \left(1+\frac{1}{2}n\right) \left(1+\frac{1}{3}n\right) \frac{\sigma}{\rho} > \left(1+\frac{1}{4}n\right)^{n+3} \cos^{2n+4} a;$$

also that there is equilibrium when  $\theta$  the inclination of the axis to the vertical is given by

$$\begin{aligned} & (1+n) \left(1+\frac{1}{2}n\right) \left(1+\frac{1}{3}n\right) \frac{\sigma}{\rho} \\ & = \left(1+\frac{1}{4}n\right)^{n+3} \cos^3 a \sec^{n+7} \theta (\cos^2 \theta - \sin^2 a)^{n+\frac{1}{2}}. \end{aligned}$$

60. A cube, whose edge is  $a$ , floats with two faces horizontal, a length  $l$  of the vertical edges being under water. Shew that the work done in turning the cube through a finite angle  $\theta$  about an axis parallel to one of the horizontal edges without altering the volume of water displaced or immersing any part of the upper face of the cube is

$$W \left[ \frac{a^2}{24l} \sin \theta \tan \theta - (a-l) \sin^2 \frac{\theta}{2} \right],$$

where  $W$  is the weight of the cube. (See Art. 105.)

61. A ship contains water in its hold and floats in the sea. A solid is held partially immersed in the hold by a machine on land, so as to displace a weight  $w$  of water; it is then depressed so that a small extra length  $\delta x$  is immersed. Prove that the gain in the potential energy of the ship and contained water is

$$\left\{ w - A \left( \frac{w}{B} + \frac{W}{C} \right) \right\} \delta x,$$

where  $W$  is the weight of the ship and the contained water,  $A$  is the area of the water section of the held solid,  $C$  is that of the ship, and  $B$  is the area of the surface of the contained water.

62. If a ship in the form of the paraboloid  $x^2/a + y^2/b = 2z$ , floating with the axis of  $z$  vertical, be displaced through a finite angle  $\theta$  about an axis in the plane of flotation so that the volume displaced remains the same, prove that the work done is

$$gp V \{ \rho \sin \theta - d(1 - \cos \theta) \},$$

where  $\rho$  is the perpendicular distance of the axis of rotation from the axis of  $z$ , and  $d$  is the distance between the centre of gravity and centre of buoyancy in the initial position.

63. Shew how to determine the effect on the trim of a ship of the displacement of a weight small compared to the total weight; prove that, if the displacement be across the horizontal deck in a direction making an angle  $\theta$  with the medial line, the resulting slope of the deck is such that the line of greatest slope makes an angle  $\tan^{-1}(m \tan \theta)$  with the medial line, where  $m$  is the ratio of the metacentric heights.

64. A log of square section floats in water with the two square faces vertical and three of the edges perpendicular to them wholly immersed. Shew that there are three positions of equilibrium with a given edge not immersed, provided the specific gravity of the substance of the log lies between  $23/32$  and  $3/4$ ; and that if this condition be satisfied the two unsymmetrical positions are stable for rolling displacement, and the symmetrical position is unstable.

65. Shew that a log of square section, floating in water, will lie in an unsymmetrical position if its density is between  $\cdot 212$  and  $\cdot 281$ , or between  $\cdot 719$  and  $\cdot 788$ ; that for intermediate densities an edge will be uppermost, for densities outside these limits a face will be uppermost.

66. A homogeneous body is floating freely in stable equilibrium. Shew that, if the body be turned upside down, so as to float with the same plane of flotation in a liquid of suitable density, the equilibrium will be stable.

67. Form an estimate of the effective increase in metacentric height when a ship is steadied by a rapidly spinning flywheel.

68. A wall-sided ship of which any cross-section is a rectangle of breadth  $2a$ , floats in the upright position immersed to a depth  $x$ , and the centre of gravity of the ship is at a height  $\frac{1}{2}h$  above the keel. The ship is heeled over through an angle  $\theta$  and maintained in equilibrium by a couple of moment  $L$ . Prove that

$$L = W \sin \theta \left\{ \frac{1}{12} \frac{a^2}{h} (3 \sec^2 \theta + 1) - \frac{1}{2} (h - x) \right\},$$

where  $W$  is the weight of the ship.

69. A uniform solid body, in the form of the portion of the paraboloid  $x^2/a^2 + y^2/b^2 = 4z/l$  cut off by the plane  $z=l$ , is floating freely in a liquid with its vertex downwards. A small weight is placed at the point  $\xi, \eta$  on its plane base, prove that those points in the plane base which suffer no vertical displacement lie on the line whose equation is

$$\frac{\xi^2}{a^2 - (1-n)l^2/3} + \frac{\eta^2}{b^2 - (1-n)l^2/3} + n = 0,$$

where  $n$  is the ratio of the density of the solid to that of the liquid.

## CHAPTER VI

### OSCILLATIONS OF FLOATING BODIES

**106.** A HEAVY body which is floating in liquid in a position of stable equilibrium, will, if slightly displaced from that position, make small vertical and angular oscillations: it is evident that the problem of these oscillations is a hydrodynamical one, and that if we neglect the motion of the liquid the results obtained for the periods of the oscillations of the body will only be inferior limits to the true periods. As far as the scope of this work permits, we can only proceed on the assumption that the inertia of the liquid is neglected, and we shall only consider a simple case. We shall suppose that the body is symmetrical with regard to a vertical plane through its centre, and that the initial displacement is parallel to this plane.

It is evident that the subsequent motions of all points of the body will be parallel to this plane, and if the equilibrium be stable, that the motion will consist of small vertical and angular oscillations.

First let the vertical line through  $G$  and  $H$  ( $CED$ ) pass through the centroid of the plane of flotation. When this is the case we can consider the vertical and angular displacements independently of each other.

Suppose a small vertical displacement; then the portion  $CE$  of the body which is raised out of the fluid may be considered as a thin cylinder.

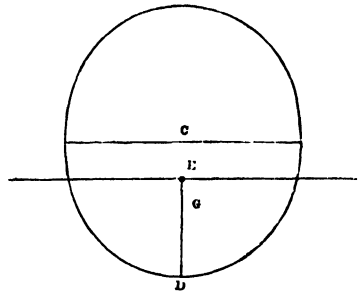

Let  $CE = z$ , then  $EG = CG - z$ , and the force downwards on the body = the weight of the body - the weight of the fluid displaced

$$= g\rho A \cdot z,$$

if  $A$  be the area of the plane of flotation ;

$$\therefore m \frac{d^2 \cdot EG}{dt^2} = g\rho Az,$$

$m$  being the mass of the body.

But  $mg =$  the weight of fluid displaced  
 $= g\rho V$ ,  $V$  being the volume  $CD$ .

$$\therefore \frac{d^2 z}{dt^2} + \frac{gA}{V} z = 0$$

is the equation which determines the motion.

The time of a complete oscillation is therefore

$$2\pi \sqrt{\left(\frac{V}{gA}\right)}.$$

**107.** Next suppose a small angular displacement ( $\alpha$ ) about  $C$ , then  $G$  is raised through a space which depends on  $\alpha^2$ , and therefore may be neglected in comparison with quantities depending upon  $\alpha$ , and if the body, supposed at rest, be then left to itself, it will (on the supposition that the equilibrium is stable) oscillate about a horizontal axis through  $G$ .

It would in fact come to the same thing if the initial displacement were about  $G$ , as the point  $C$  would move sensibly (that is, considering small quantities of the first order only) in a horizontal direction, and the quantity of fluid displaced would, as before, remain unchanged.

If  $M$  be the metacentre, the moment of the fluid pressure about  $G$

$$= g\rho V \cdot MG \cdot \sin \theta,$$

and tends to diminish  $\theta$ , the angle made by  $GH$  with the vertical at the time  $t$ .

But 
$$MG = \frac{k^2 A}{V} - a, \text{ if } HG = a ;$$

therefore, since the horizontal axis through  $G$  is a principal axis, we have

$$mK^2 \frac{d^2 \theta}{dt^2} = -g\rho (k^2 A - aV) \theta,$$

neglecting higher powers of  $\theta$ , where  $mK^2$  is the moment of inertia of the body about the horizontal axis through  $G$ , or

$$K^2 \frac{d^2 \theta}{dt^2} + g \left( \frac{k^2 A}{V} - a \right) \theta = 0,$$

an equation which, when  $k^2A > aV$ , that is, when  $M$  is above  $G$ , indicates small oscillations taking place in the time

$$2\pi K \sqrt{\left\{ \frac{V}{g(k^2A - aV)} \right\}}.$$

If  $G$  is below  $H$  the sign of  $a$  will of course be changed.

It will be seen that the criterion of stability is deducible from the result just obtained; it is an obvious condition for an oscillation that  $k^2A - aV$  must be a positive quantity.

**108.** Secondly when the line joining  $H$  and  $G$  does not pass through  $C$ , the two motions are not independent, but the law which defines these motions can be determined as follows.

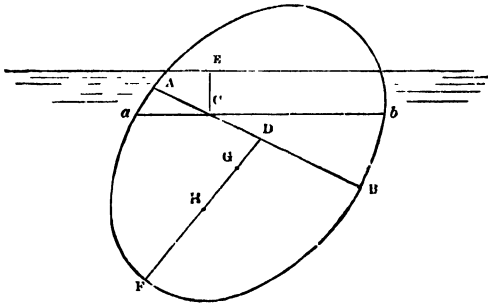

Suppose the body to be slightly displaced in the vertical plane of symmetry, and then left to itself; and at the time  $t$  let  $\theta$  be the angle made by  $HG$  with the vertical, and  $z = CE$  the depth of  $C$  below the surface.

Let  $HG$  meet the plane of flotation in  $D$ ,

$$HG = a, \quad CD = b, \quad DG = c,$$

and other symbols as before.

$$\begin{aligned} \text{Then the depth of } G &= z + b \sin \theta + c \cos \theta \\ &= z + b\theta + c, \text{ to the order considered.} \end{aligned}$$

The weight of the fluid displaced is the weight of a volume of fluid equal to

$$\begin{aligned} aFb + EC, \text{ or } AFB + EC; \\ \text{this weight} &= g\rho V + g\rho Az, \end{aligned}$$

and  $\therefore m \frac{d^2}{dt^2} (z + c + b\theta) = mg - (g\rho V + g\rho Az)$   
 $= -g\rho Az;$

or  $\frac{d^2z}{dt^2} + b \frac{d^2\theta}{dt^2} = -g \frac{A}{V} z \dots\dots\dots(I).$

Another equation is to be obtained from the consideration of the angular motion about the horizontal axis through  $G$ , which is a principal axis, perpendicular to the plane of displacement.

The moment of the fluid pressure about  $G$  may be divided into two parts, the one due to the portion  $aFb$ , and the other to the portion  $EC$  of the fluid displaced.

The former part of the fluid pressure =  $g\rho V$  acting upwards through  $M$  the metacentre; and the latter =  $g\rho Az$ , and may be considered to act through  $C$  the centroid of the plane of flotation.

The moment, in the direction tending to diminish  $\theta$ ,

$$\begin{aligned} &= g\rho V \cdot GM \sin \theta - g\rho Az (b \cos \theta - c \sin \theta) \\ &= g\rho (k^2 A - aV) \theta - g\rho Az (b - c\theta) \\ &= g\rho (k^2 A - aV) \theta - g\rho Abz, \end{aligned}$$

neglecting the product of  $z$  and  $\theta$ ;

$$\therefore mK^2 \frac{d^2\theta}{dt^2} = -g\rho (k^2 A - aV) \theta + g\rho Abz.$$

$$K^2 \frac{d^2\theta}{dt^2} = -g \left( \frac{k^2 A}{V} - a \right) \theta + g \frac{A}{V} \cdot bz \dots \dots \dots (II).$$

From the equations (I) and (II) we obtain

$$\begin{aligned} \frac{d^2z}{dt^2} + \frac{gA}{V} \left( 1 + \frac{b^2}{K^2} \right) z - \frac{gb}{K^2} \left( \frac{k^2 A}{V} - a \right) \theta &= 0, \\ \frac{d^2\theta}{dt^2} - \frac{gAb}{VK^2} z + \frac{g}{K^2} \left( \frac{k^2 A}{V} - a \right) \theta &= 0, \end{aligned}$$

which may be written

$$\left. \begin{aligned} \frac{d^2z}{dt^2} + rz - bn\theta &= 0, \\ \frac{d^2\theta}{dt^2} - \frac{pz}{b} + n\theta &= 0. \end{aligned} \right\} \dots \dots \dots (III).$$

To integrate these equations, multiply the second by  $\lambda$ , and add it to the first, then,

assuming  $\frac{\lambda n - bn}{rb - \lambda p} = \frac{\lambda}{b} \dots \dots \dots (IV),$

we have  $\frac{d^2}{dt^2} (z + \lambda\theta) + \left( r - \frac{\lambda p}{b} \right) (z + \lambda\theta) = 0,$

and, if  $\lambda_1, \lambda_2$  be the roots of (IV),

$$\left. \begin{aligned} z + \lambda_1 \theta &= C_1 \cos \left\{ \sqrt{r - \lambda_1 \frac{p}{b}} t + \alpha_1 \right\} \\ z + \lambda_2 \theta &= C_2 \cos \left\{ \sqrt{r - \lambda_2 \frac{p}{b}} t + \alpha_2 \right\} \end{aligned} \right\} \dots \dots \dots (V),$$

from which  $z$  and  $\theta$  are completely determined.

The depth of  $G$  is given by an expression of the form

$$C + A \cos (\mu t + \alpha) + B \cos (\mu' t + \beta),$$

and its motion consists of two distinct oscillations, each following the pendulum laws, and compounded together in accordance with the principle of the coexistence of small oscillations.

It may be observed that if two points be taken in the line  $AB$ , whose distances from  $C$  in the direction  $CD$  are  $\lambda_1, \lambda_2$ , then at the time  $t$ , the vertical depths of these points are  $z + \lambda_1\theta$  and  $z + \lambda_2\theta$ , that is, are

$$C_1 \cos \left\{ \sqrt{r - \lambda_1 \frac{p}{b}} t + \alpha_1 \right\}, \text{ and } C_2 \cos \left\{ \sqrt{r - \lambda_2 \frac{p}{b}} t + \alpha_2 \right\},$$

and their vertical motions are therefore simple oscillations following the pendulum law. This remark is quoted by Duhamel (*Cours de Mécanique*, Art. 152) as due to M. Cauchy.

Equations (V) represent the 'normal modes' of vibration. The periods  $2\pi/q$  of the oscillations could be obtained more simply by substituting  $z = A \cos (qt + \epsilon)$ , and  $\theta = B \cos (qt + \epsilon)$  in equations (III) and eliminating the ratio  $A/B$  from the result.

EXAMPLES.

1. A straight rod is dropped vertically from a given height above the surface of water; determine its motion and find the condition that it may be only just immersed.

2. A vertical cylinder of height  $h$  floats in a liquid of twice its own density contained in a cylindrical vessel. If the radius of the vessel be double that of the cylinder, and the cylinder be slightly displaced in a vertical direction, prove that the time of an oscillation is  $\pi\sqrt{3h/2g}$ .

3. A solid, the lower portion of whose surface is spherical, floats in a heavy fluid; shew that the time of a small angular oscillation is the same in whatever homogeneous fluid it floats.

\* 4. A hollow hemisphere moveable about a horizontal diameter is partly filled with fluid; shew that the time of a small oscillation is the same as if there were no fluid in it.

5. A solid ellipsoid floats in a liquid of twice its own specific gravity with its shortest axis vertical; find the time of a small vertical oscillation, and also the times of small angular oscillations about the two horizontal axes.

\* 6. A cube (the length of whose edge is  $2a$ ) is floating in a fluid with its centre of gravity at a depth  $c$  below the surface; if it receive a small displacement so that two of its faces remain vertical, shew that the times of its small vertical and angular oscillations are

$$2\pi \sqrt{\left(\frac{a+c}{g}\right)} \text{ and } 4\pi \sqrt{\left\{\frac{a^2(a+c)}{g(3c^2-a^2)}\right\}}, \text{ respectively.}$$

7. A cylinder makes vertical oscillations in a liquid contained in another cylinder, the radius of which is  $n$  times that of the former; shew that the length of the axis immersed when in a position of rest is

$$gt^2n^2 \div 4\pi^2(n^2 - 1),$$

where  $t$  is the time of a complete oscillation.

8. A candle of density  $\rho$  floats vertically in still water of density  $\sigma$ . It is lighted and the flame is observed to descend towards the water with uniform velocity  $u$ , and the velocity with which the candle burns is  $v$ : prove that

$$v(\sigma - \rho) = \sigma u.$$

Prove also, that if the flame be extinguished when a length  $l$  of candle remains, the candle will rise out of the water if  $v$  be  $> \sqrt{\sigma l g / \rho}$ ; but if  $v$  be  $< \sqrt{\sigma l g / \rho}$  the time of an oscillation will be  $2\pi \sqrt{\rho l / \sigma g}$ .

9. A right cone is floating with its axis vertical and vertex downwards in a fluid, and  $\frac{1}{n}$ th part of the axis is immersed; a weight equal to the weight of the cone is placed on the base, upon which the cone sinks till its axis is totally immersed, before rising; shew that

$$n^3 + n^2 + n = 7.$$

10. A cone of vertical angle  $2a$  floats in a cylinder of radius  $a$  with a length  $\alpha$  of its axis immersed. If it be pushed vertically downwards through a small space, shew that the time of an oscillation is

$$2\pi \sqrt{\frac{(\alpha^2 - h^2 \tan^2 a) h}{3\alpha^2 g}}.$$

11. A vessel, in the form of a paraboloid of revolution with its axis vertical, contains a quantity of liquid equal in volume to that of a segment of a paraboloid, of the same latus rectum, floating in it: if this be raised till its vertex is just on the surface, and if it then sink to a depth equal to  $3/4$  of its axis before returning, prove that the density of the liquid : that of the paraboloid :: 48 : 7.

12. A solid cone, of given vertical angle, is supported on an axis, about which it is moveable, coincident with a diameter of its base; if the axis be held horizontally, and lowered until one-eighth of the volume of the cone, vertex downwards, is immersed in homogeneous liquid, find the ratio of the densities of the liquid and cone, when the equilibrium is neutral.

If, in the previous case, the axis be not lowered so far as to make the equilibrium neutral, and the cone be then slightly displaced, find the time of a small oscillation.

13. An oblate spheroid is completely immersed in two fluids, the specific gravity of the lower being twice that of the upper fluid, and floats with its axis vertical, and its centre in the common surface of the fluids.

Supposing a small displacement to take place, 1st, in a vertical direction, 2ndly, about a horizontal line through its centre of gravity, shew that the times of the small oscillations will be respectively

$$2\pi \sqrt{\left(\frac{2b}{g}\right)}, \text{ and } 2\pi \sqrt{\left(\frac{8}{5} \frac{b\alpha^2 + b^2}{g\alpha^2 - b^2}\right)},$$

where  $\alpha$  and  $b$  are the semi-axes of the generating ellipse.

14. A homogeneous solid floats completely immersed in a liquid, the density of which varies as the depth, with its centre of gravity at a depth  $h$ ; prove that the time of a small vertical oscillation is  $2\pi \sqrt{h/g}$ .

15. A lamina of uniform thickness, in the form of an isosceles right-angled triangle, has one of the acute angles fixed below the surface of a fluid, and rests with the side which is not immersed horizontal. Prove that the time of a small oscillation in its own plane is

$$2\pi \sqrt{\alpha/g},$$

where  $\alpha$  is the length of each of the sides of the triangle.

16. A solid generated by the revolution of the curve,  $y \propto x^{\frac{n}{2}-1}$ , about the axis of  $x$ , floats with a portion  $h$  of the axis immersed; if the solid be depressed through  $(n^{\frac{1}{2}-1}-1)h$ , it will, on its return, just emerge.

17. A solid of revolution of mass  $m$  floats in different liquids. If the time of vertical oscillation in any liquid and its density  $\rho$  are found to be connected by the equation

$$\frac{1}{\rho} = f\left(\frac{1}{\xi^2 \rho}\right),$$

$f$  denoting a given function, show that the equation to the meridian section of the solid is

$$\frac{2\pi^2}{g} (r+r') = \int \frac{dy}{y} f\left(\frac{yy^2}{4\pi m}\right).$$

18. A uniform wedge, whose section perpendicular to its edge is everywhere an isosceles triangle of which the semi-vertical angle is  $\tan^{-1} \sqrt{2}$  and base  $b$ , floats with its edge fixed in the surface of a liquid of twice its specific gravity: it is then depressed through a small angle  $B$  about the vertex: prove that the time in which it will return to its original position is approximately

$$\frac{1}{8B} \sqrt{\frac{5b}{\pi g}} \left\{ \Gamma\left(\frac{1}{4}\right) \right\}^2.$$

## CHAPTER VII

### PRESSURE OF THE ATMOSPHERE

109. If a glass tube, about three feet in length, having one end closed, be filled with mercury, and then inverted in a vessel of mercury so as to immerse its open end, it will be found that the mercury will descend in the tube, and rest with its upper surface at a height of about 29 inches above the surface of the mercury in the vessel: this experiment, first made by Torricelli, has suggested the use of the *Barometer*, for the purpose of measuring the atmospheric pressure.

The *Barometer*, in its simplest form, is a straight glass tube  $AB$ , containing mercury, and having its lower end immersed in a small cistern of mercury; the end  $A$  is hermetically sealed, and there is no air in the branch  $AB$ .

It is found that the height of the surface  $P$  of the mercury above the surface  $C$  is about 29 inches, and, as there is no pressure on the surface  $P$ , it is clear that the pressure of the air on  $C$  is the force which sustains the column of mercury  $PQ$ .

We have shewn that the pressure of a fluid at rest is the same at all points of the same horizontal plane; hence the pressure at  $C$  is equal to the pressure of the mercury at  $Q$ .

Let  $\sigma$  be the density of mercury, and  $\Pi$  the atmospheric pressure at  $C$ , then

$$\Pi = g\sigma PQ,$$

and the height  $PQ$  measures the atmospheric pressure.

On account of its great density, mercury is the most convenient fluid which can be employed in the construction of barometers, but the pressure of the air may be measured by using any kind of liquid. The density of mercury is about 13.568 times that of water, and therefore the height of the column of water in the water-barometer would be about  $33\frac{3}{4}$  feet.

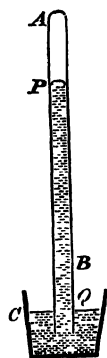

The density of mercury changes with the temperature, and  $\sigma$  must therefore be expressed as a function of the temperature.

Experiment shews that, for an increase of  $1^\circ$  centigrade, the expansion of mercury is  $\frac{1}{5550}$ th of its volume; hence if  $\sigma_t$  be the density at a temperature  $t^\circ$ , and  $\sigma_0$  at a temperature  $0^\circ$ ,

$$\sigma_0 = \sigma_t \left( 1 + \frac{t}{5550} \right) = \sigma_t (1 + \cdot 00018018t);$$

$$\therefore \sigma_t = \sigma_0 (1 - \theta t) \text{ if } \theta = \cdot 00018018,$$

and

$$\Pi = g\sigma_0 (1 - \theta t) PQ. \quad \checkmark$$

By means of the formula,  $\Pi = g\sigma_0 (1 - \theta t) h$ , the atmospheric pressure at any place can be calculated, making due allowance for the change in the value of  $g$  consequent on a change of latitude. It is found that this pressure is variable at the same place, with or without changes of temperature, and that in ascending mountains, or in any way rising above the level of the place, the pressure diminishes. This is in accordance with the theory of the equilibrium of fluids, for, in ascending, the height of the column of air above the barometer is diminished, and the pressure of the air upon  $C$ , which is equal to the weight of the superincumbent column of air, is therefore diminished, and the mercury must descend in the tube.

If then a relation be found between the height of the mercury and the height through which an ascent has been made, it is clear that by observations, at the *same* time, of the barometric columns at two stations, we shall be able to determine the difference of their altitudes.

We shall investigate a formula for this purpose; but it is first necessary to state the laws which regulate the pressures of the air and gases at different temperatures, and also the laws of the mixture of gases.

**110.** We have before stated the relation

$$p = k\rho (1 + \alpha t)$$

between the pressure, density, and temperature of an elastic fluid: it is deduced from the two following results of experiment:

(1) *If the temperature be constant, the pressure of air varies inversely as its volume. (Boyle's Law.)*

(2) *If the pressure remain constant, an increase of temperature of 1° C. produces in a mass of air an expansion .003665 of its volume at 0° C. (Dalton's and Gay-Lussac's Law.)*

Hence, if  $p$  be the pressure and  $\rho_0$  the density of air, at a temperature zero,

$$p = k\rho_0.$$

Suppose now the temperature increased to  $t$ , the pressure remaining the same: the conception of this may be assisted by considering the air to be contained in a cylinder in which a moveable piston fits closely, and has applied to it a constant force, so that an increase of the elastic force of the air would have the effect of pushing out the piston, until the equilibrium is restored by the diminution of density, and consequent diminution of pressure: we shall then have from the 2nd law,

$$\rho_0 = \rho(1 + \alpha t),$$

taking  $\rho$  as the new density and  $\alpha = .003665$ ;

$$\therefore p = k\rho(1 + \alpha t).$$

If  $p'$ ,  $\rho'$  be the pressure and density of the same fluid at a temperature  $t'$ ,

$$p' = k\rho'(1 + \alpha t'),$$

and

$$\frac{p}{p'} = \frac{\rho}{\rho'} \frac{1 + \alpha t}{1 + \alpha t'}.$$

The quantity  $\alpha$  is very nearly the same for gases of all kinds, but  $k$  has different values for different gases, and must of course be determined experimentally in every case.

**111. Absolute Temperature.** If we imagine the temperature of a gas lowered until its pressure vanishes, without any change of volume, we arrive at what is called the absolute zero of temperature, and absolute temperature is measured from this point.

Assuming  $t_0$  to represent this temperature on the centigrade thermometer, we obtain, from the equation  $1 + \alpha t_0 = 0$ ,

$$t_0 = -\frac{1}{\alpha} = -273.$$

In Fahrenheit's scale the reading for absolute zero is  $-459^\circ$ .

The equations,

$$p = k\rho(1 + \alpha t),$$

$$0 = k\rho(1 + \alpha t_0),$$

lead to

$$p = k\rho\alpha(t - t_0)$$

$$= k\rho\alpha T,$$

if  $T$  be the absolute temperature.

Since  $\rho V$  is constant, it follows that  $pV/T$  is constant, and this law expresses, in the absolute scale, the relation between pressure, volume, and temperature.

**112. Mixtures.** *The pressure of a mixture of different elastic fluids.*

Consider two different gases, contained in vessels of which the volumes are  $V$  and  $V'$ , and let their pressures and temperatures,  $p$  and  $t$ , be the same.

Let a communication be established between the two vessels, or transfer both the gases to a closed vessel, the volume of which is  $V + V'$ : it is found in the case in which no chemical action takes place, that the two gases do not remain separate, but permeate each other until they are completely mixed, and that, when equilibrium is attained, the pressure and temperature are the same as before. From this important experimental fact we can deduce the following proposition.

*If two gases having the same temperature be mixed together in a vessel, the volume of which is  $V$ , and if the pressure of the two gases, alone filling the volume  $V$ , be  $p$  and  $p'$ , the pressure of the mixture will be  $p + p'$ .*

Suppose the two gases separated; let the gas, of which the pressure is  $p$ , have its volume changed, without any alteration of temperature, until its pressure becomes  $p'$ ; its volume will be, by Boyle's law,  $pV/p'$ .

Let the two gases be now mixed in a vessel, of which the volume is

$$V + \frac{p}{p'} V, \text{ or } \frac{p+p'}{p'} V;$$

the pressure of the mixture will still be  $p'$ , and the temperature will be unaltered. If the mixture be then compressed into a volume  $V$ , its pressure will become, by the application again of Boyle's law,  $p + p'$ .

This result is obviously true for a mixture of any number of gases.

**113.** *Two volumes  $V$ ,  $V'$  of different gases, at pressures  $p$ ,  $p'$  respectively, are mixed together, so that the volume of the mixture is  $U$ ; to find the pressure of the mixture.*

The pressures of the two gases, reduced to the volume  $U$ , are respectively

$$\frac{V}{U}p, \quad \frac{V'}{U}p',$$

and therefore, by the preceding article, the pressure of the mixture is

$$\frac{V}{U}p + \frac{V'}{U}p';$$

and if  $\varpi$  be this pressure, we have

$$\varpi U = pV + p'V'.$$

If the absolute temperatures of the gases before mixture are  $T$  and  $T'$ , and if after mixture the absolute temperature is  $\tau$ , and the volume  $U$ , the pressures of the gases will be respectively

$$\frac{pV}{T} \frac{\tau}{U} \quad \text{and} \quad \frac{p'V'}{T'} \frac{\tau}{U}.$$

Hence  $\varpi$ , the pressure of the mixture, is the sum of these two quantities, and therefore

$$\frac{\varpi U}{\tau} = \frac{pV}{T} + \frac{p'V'}{T'}.$$

In the case of the mixture of any number of gases, we have

$$\frac{\varpi U}{\tau} = \sum \frac{pV}{T}.$$

**114.** The laws and results of the preceding articles are equally true of vapours, the only difference between the mechanical qualities of vapours and gases, irrespective of their chemical characteristics, being that the former are easily condensed into liquid by lowering the temperature, while the latter can only be condensed by the application either of great pressure or extreme cold, or a combination of both\*.

\* Professor Faraday succeeded in condensing carbonic acid gas, and other gases requiring a considerable pressure for the purpose, and the result of his experiments led to the conclusion that, in all probability, all gases are the vapours of liquids. This conclusion was remarkably supported in 1877, when M. Pictet, in the early part of the year, liquefied oxygen by applying to it a pressure of 300 atmospheres, and, in December of the same year, M. Cailletet liquefied nitrogen, and atmospheric air. In 1884 hydrogen was liquefied by Wroblewski, in 1899 Dewar obtained solid hydrogen, and now liquid air and various other gases in liquid form are articles of commerce.

**115. Vapour.** If water be introduced into a space containing dry air, vapour is immediately formed, and it is found that the pressure and density of the vapour are dependent only on the temperature, and are quite independent of the density of the air, and indeed are exactly the same if the air be removed. If the temperature be increased or the space enlarged, an additional quantity of vapour will be formed, but if the temperature be lowered or the space diminished, some portion of the vapour will be condensed.

While a sufficient quantity of water remains, as a source from which vapour is supplied, the space will be always saturated with vapour, that is, there will be as much vapour as the temperature admits of; but if the temperature be so raised that all the water is turned into vapour, then for that, and all higher temperatures, the pressure of the vapour will follow the same law as the pressure of the air.

In any case, whether the space be saturated or not, if  $p$  be the pressure of the air, and  $\varpi$  of the vapour, the pressure of the mixture is  $p + \varpi$ .

**116.** The atmosphere always contains aqueous vapour, the quantity being greater or less at different times; if any portion of the space occupied by the atmosphere be saturated with vapour, that is, if the density of the vapour be as great as it can be for the temperature, then any reduction of temperature will produce condensation of some portion of the vapour, but if the density of the vapour be not at its maximum for that temperature, no condensation will take place until the temperature is lowered below the point corresponding to the saturation of the space.

**Formation of Dew.** If any surface, in contact with the atmosphere, be cooled down below the temperature corresponding to the saturation of the space near it, condensation of the aqueous vapour will ensue, and the condensed vapour will be deposited in the form of *dew* upon the surface. The formation of dew on the ground depends therefore on the cooling of its surface, and this is in general greater and more quickly effected, when the sky is free from clouds, and when, consequently, the loss of heat by radiation is greater than under other circumstances.

The **Dew Point** is the temperature at which dew first begins to be formed, and must be determined by actual observation.

The pressure of vapour corresponding to its saturating densities for different temperatures must also be determined experimentally, and, if this be effected, an observation of the dew point at once determines the pressure of the vapour in the atmosphere. For if  $t'$  be the dew point, and  $p'$  the known corresponding pressure, then at any other temperature  $t$  above  $t'$  the pressure  $p$  is given by the equation

$$\frac{p}{p'} = \frac{1 + \alpha t}{1 + \alpha t'}$$

**117. Effect of compression or dilatation on the pressure and temperature of a gas.**

It is found by experiment that if a quantity of air, enclosed in a vessel impervious to heat, be compressed, its temperature is raised; and that, if a quantity of air, enclosed in any kind of vessel, be suddenly compressed, so that there is no time for the heat to escape, the temperature is similarly raised.

**118. Thermal Capacity.** The thermal capacity of a body is measured by the amount of heat required to raise the temperature one degree.

The unit of heat which is actually employed is the quantity of heat required to raise by one degree the temperature of one unit of mass of water, supposed to be between  $0^{\circ}$  C. and  $40^{\circ}$  C.

**Specific Heat.** The specific heat of a body is the thermal capacity of one unit of mass, or, which is the same thing, it is the ratio of the amount of heat required to increase by  $1^{\circ}$  the temperature of the body to the amount of heat required to increase by  $1^{\circ}$  the temperature of an equal weight of water.

If an amount of heat  $dQ$  produce in the unit of mass a change of temperature  $dt$ , the measure of the specific heat is  $\frac{dQ}{dt}$ .

In gases it is necessary to consider two cases; (1) when the pressure remains constant, the gas being allowed to expand, (2) when the volume remains constant.

We shall denote the specific heat in these two cases by the symbols  $c_p$  and  $c_v$ .

It is easy to see that  $c_p$  is greater than  $c_v$ , for in the first case the heat imparted does work in expanding the gas as well as in raising its temperature.

**119. Adiabatic expansion.** To determine the effect of a compression or a dilatation of a given quantity of gas, it is clear to begin with that the heat required will be a function of  $v$ ,  $p$ , and  $T$ , and since  $pv \propto T$ , the heat required for any expansion will be a function of  $v$  and  $p$ . Therefore it follows that

$$dQ = \frac{\partial Q}{\partial v} dv + \frac{\partial Q}{\partial p} dp,$$

and, in general,  $p = k\rho\alpha T$  or, if the mass of the given quantity of gas be the unit of mass,

$$pv = k\alpha T = KT.$$

If the pressure be constant,  $dQ = c_p dT$ ;

$$\therefore \frac{\partial Q}{\partial v} dv = c_p dT = c_p \frac{p dv}{K}$$

and

$$\frac{\partial Q}{\partial v} = \frac{c_p}{K} p.$$

If the volume be constant,

$$\frac{\partial Q}{\partial p} dp = c_v dT = c_v \frac{v dp}{K}$$

and

$$\frac{\partial Q}{\partial p} = \frac{c_v}{K} v.$$

Therefore, if no heat be imparted, that is, if  $dQ = 0$ ,

$$c_p \frac{dv}{v} + c_v \frac{dp}{p} = 0;$$

$$\therefore p^{c_v} v^{c_p} \text{ is constant,}$$

if we assume that the ratio of  $c_v$  to  $c_p$  is constant.

If  $p$ ,  $v$  be changed to  $p'$ ,  $v'$ , we obtain

$$\frac{p'}{p} = \left(\frac{v'}{v}\right)^\gamma,$$

where  $\gamma = c_p/c_v$ , and

$$\frac{T'}{T} = \frac{p'v'}{pv} = \left(\frac{v'}{v}\right)^{\gamma-1}.$$

The equation  $pv^\gamma = \text{constant}$  is, in thermodynamics, the equation of the adiabatic, or isentropic lines, and it represents the relation between the pressure and volume of a mass of gas, when, during a change of volume, no heat is lost or imparted.

The equation is true in the case of a sudden compression or dilatation of a mass of air, because there is no time for any sensible loss of heat, or for any addition of heat from external sources. It will be found that this relation is of great importance in the theory of sound.

**120.  $c_p - c_v$  constant.** It can be shewn by the aid of the principle of energy that the difference between  $c_p$  and  $c_v$ , for any given gas, is constant.

By a law of thermodynamics, the energy imparted to a system by the application of heat is proportional to the amount of heat.

Hence,  $J$  being the mechanical equivalent of the unit of heat, the energy imparted to the unit mass of a gas by a rise of temperature  $dT$  when the pressure is constant is

$$J \cdot c_p dT.$$

But this energy is partly expended in elevating the temperature at a given volume, and partly in expanding the volume ;

$$\therefore J \cdot c_p dT = pdv + J \cdot c_v dT$$

and

$$pv = KT,$$

$$\therefore J(c_p - c_v) = K,$$

shewing that  $c_p - c_v$  is constant.

We can employ this equation in obtaining the result of Art. (119).

For, if no heat be supplied, no energy is imparted,

and

$$\therefore pdv + J \cdot c_v dT = 0.$$

But

$$pv = KT = J \cdot (c_p - c_v) T;$$

$$\therefore pdv + vdp = J \cdot (c_p - c_v) dT,$$

and

$$pdv (c_p - c_v) + c_v (pdv + vdp) = 0,$$

whence

$$c_p \cdot pdv + c_v \cdot vdp = 0, \text{ as before.}$$

**121. *The work done during an adiabatic compression of a gas.***

In Art. (14) we have assumed that the temperature is constant, or in other words that the compression is isothermal.

This state of things can be secured by performing the operation so slowly that any heat which may be generated is dissipated during the process.

If the compression is adiabatic, that is, if the process is so arranged that no heat is lost or imparted, which is practically the case when the compression is very rapid, we have from Art. (119) the relation

$$pv^\gamma = \text{constant} = C.$$

Hence it follows that the work done in compressing from volume  $V$  to volume  $U$

$$\begin{aligned} &= - \int p dv = - \int C v^{-\gamma} dv \\ &= \frac{C}{1-\gamma} \left( V^{1-\gamma} - U^{1-\gamma} \right). \end{aligned}$$

*Whole mass of the earth's atmosphere.*

**122.** Some idea may be formed of the mass of air and vapour surrounding the earth by means of the barometer. Supposing the earth to be a sphere of radius  $r$ , and that the height of the barometric column,  $h$ , is the same at all points of its surface, the mass of the atmosphere is approximately equivalent to the mass  $4\pi\sigma r^2 h$  of mercury.

Let  $\rho$  be the mean density of the earth ;  
then, the mass of the atmosphere : the mass of the earth

$$\begin{aligned} &= 4\pi\sigma r^2 h : \frac{4}{3}\pi\rho r^3 \\ &= 3\sigma h : \rho r. \end{aligned}$$

But, taking water as the standard substance,  $\sigma = 13.57$ , and  $\rho$  has been found to be about 5.5 ; and, if we take 29.9 inches as an approximate value of  $h$ , it will be found that the ratio of the masses is somewhat less than the ratio of one to a million\*.

*The height of the homogeneous atmosphere.*

**123.** If the whole column of air had the same density throughout as at the surface, its height being  $l$ , and the height of the mercury being  $h$ , we should have

$$\sigma h = \rho l,$$

where  $\rho$  is the density of the air. It has been found that the ratio  $\sigma : \rho$  is about 10462 : 1, and therefore employing as before 29.9 as a value of  $h$ , it will be found that  $l$  is a little less than 5 miles.

*Necessary limit to the height of the atmosphere.*

It is clear that, since at a distance from the earth's surface its attraction diminishes, and the density and pressure of the air are

\* The mean density of the earth has been frequently the subject of calculation based on experiment : v. J. H. Poynting, Adams Prize Essay 1893, where the result obtained is 5.4934. C. V. Boys, *Phil. Trans.* 1895, and C. Braun, *Denkschrift d. math. naturw. Klasse d. Wiener Akad.* 1896-7 give the result 5.527. See also Article *Gravitation Constant and mean density of the earth*, by J. H. Poynting, *Encycl. Brit.* eleventh edition.

therefore diminished, the above result is very far from the truth. A *limit* to the height can however be found from the consideration that, beyond a certain distance from the earth's centre, its attraction will be unable to retain the particles of air in the circular paths, which they must describe about the earth, in order to remain in a state of relative equilibrium.

At the equator the expression  $\omega^2 r$ ,  $\omega$  being the earth's angular velocity, is equal to  $g/289$ , and therefore, at a height  $z$ , the force necessary to retain a particle  $m$  of air in its circular motion is equal to  $mg(r+z)/289r$ ; the earth's attraction at the same height

$$= \frac{mgr^2}{(r+z)^2};$$

and the extreme height is given by the equation

$$\frac{r^2}{(r+z)^2} = \frac{r+z}{289r}$$

or

$$z = r \{ \sqrt[3]{(289) - 1} \},$$

that is,  $z$  is a little greater than  $5r$ .

It is possible however that this height is considerably beyond the true height, for the temperature of the air has been found, by experiments made in balloons, to diminish with great rapidity during an ascent, and it is therefore quite possible, that, at a height less than  $5r$ , the air may be liquefied by extreme cold, and its external surface would be, in that case, of the same kind as the surfaces of known inelastic fluids.

*The determination of heights by the barometer.*

**124.** In attempting to establish a relation between the height of the mercury column of a barometer and the height of the instrument above sea-level, we must make a hypothesis about the temperature of the atmosphere. First let us suppose the temperature to be constant and that  $p, \rho$  denote the pressure and density at a height  $z$ , and  $p', \rho'$  their values at a height  $z'$ ; then the equations of equilibrium are

$$dp = -g\rho dz,$$

and

$$p/\rho = p'/\rho' = k;$$

$$\therefore k \log p = C - gz.$$

$$\therefore \log \frac{p}{p'} = \frac{g}{k} (z' - z).$$

Also if  $h, h'$  denote the heights of the barometer at two stations whose heights are  $z$  and  $z'$ , then

$$z' - z = \frac{k}{g} \log \frac{p}{p'} = \frac{k}{g} \log \frac{h}{h'} \dots\dots\dots (1).$$

If the temperature be not constant, let  $\tau, \tau'$  be the temperatures at the two stations; then if we proceed on the hypothesis of a mean uniform temperature  $t = \frac{1}{2} (\tau + \tau')$  between the two levels, the relation between  $p$  and  $\rho$  is now  $p = k\rho (1 + \alpha t)$ , and equation (1) becomes

$$z' - z = \frac{k}{g} \left\{ 1 + \frac{1}{2} \alpha (\tau + \tau') \right\} \log \frac{h}{h'} \dots\dots\dots (2),$$

and if we also allow for the difference in the temperature of the mercury in the barometer at the two stations, we have by Art. (109)

$$\frac{p}{p'} = \frac{h(1 - \theta\tau)}{h'(1 - \theta\tau')}, \text{ where } \theta = \cdot 00018018;$$

and equation (2) becomes

$$z' - z = \frac{k}{g} \left\{ 1 + \frac{1}{2} \alpha (\tau + \tau') \right\} \log \frac{h(1 - \theta\tau)}{h'(1 - \theta\tau')} \dots\dots (3).$$

**125.** If however the heights above the earth's surface be considerable, it is necessary to take account of the variation of gravity at different distances from the earth's centre. We proceed then to an investigation of a more exact formula.

Let  $g$  be the measure of gravity at the level of the sea, and  $r$  the radius of the earth; then, at a height  $z$ , the attractive force is measured by

$$g \frac{r^2}{(r + z)^2},$$

and the equation of equilibrium is

$$dp = -g \frac{r^2}{(r + z)^2} \rho dz;$$

we have also  $p = k\rho (1 + \alpha t)$ , and it is here important to observe that  $p$  is the sum of the pressures due to the air itself, and to the aqueous vapour which is mixed with it, so that, if  $\rho'$  be the density of the aqueous vapour,  $p$  is the sum of two quantities of the form

$$k\rho (1 + \alpha t) + k'\rho' (1 + \alpha t),$$

and therefore the quantity  $k\rho$  in the above equation is the sum of the two  $k\rho, k'\rho'$ , corresponding respectively to the air and the aqueous vapour.

From the two equations above we obtain

$$k \frac{dp}{p} = - \frac{1}{1 + at} \frac{gr^2 dz}{(r+z)^2},$$

and, as before, we shall consider  $t$  constant, and equal to the mean of the temperatures at the two stations.

By integration

$$k \log p = \frac{1}{1 + at} \frac{gr^2}{r+z} + C,$$

and  $\therefore k \log \frac{p'}{p} = \frac{gr^2(z-z')}{(1+at)(r+z)(r+z')} \dots \dots \dots (1).$

Let  $h, h'$  be the observed heights of the mercury, and  $\tau, \tau'$  the temperatures, as before; then, since the force of gravity at a height  $z$  is measured by the quantity  $\frac{gr^2}{(r+z)^2}$ , we have

$$p = \frac{gr^2}{(r+z)^2} \sigma h (1 - \theta\tau),$$

$$p' = \frac{gr^2}{(r+z')^2} \sigma h' (1 - \theta\tau'),$$

$$\frac{p'}{p} = \left(\frac{r+z}{r+z'}\right)^2 \frac{1 - \theta\tau' h'}{1 - \theta\tau h} \dots \dots \dots (2),$$

and therefore, observing that  $\theta$  is a very small quantity,

$$z - z' = \frac{k(1+at)(r+z)(r+z')}{\mu gr^2} \left\{ \log_{10} \frac{h'}{h} + 2 \log_{10} \frac{r+z}{r+z'} - \mu\theta(\tau' - \tau) \right\},$$

where  $\mu = \log_{10} e = .4342945$ .

From this formula, if  $z'$  be known, the value of  $z$  can be calculated.

If the lower station be nearly at the level of the sea,  $z' = 0$ , and

$$z = \frac{k(1+at)}{\mu g} \left(1 + \frac{z}{r}\right) \left\{ \log_{10} \frac{h'}{h} + 2 \log_{10} \left(1 + \frac{z}{r}\right) - \mu\theta(\tau' - \tau) \right\} \dots (3).$$

**126.** In the preceding investigation we have taken no account of the variation of gravity at different parts of the earth's surface. On account of the spheroidal shape of the earth and its rotation about its axis the value of the force of gravity differs in different latitudes, and in consequence of the constitution of the earth's

crust the value differs on land and sea and has been found to be greater on small oceanic islands than on continents.

A recent formula for the mean value of  $g$  is

$$g = 978.046 (1 + .005302 \sin^2 \phi - .000007 \sin^2 2\phi) \text{ cm./sec.}^2,$$

or  $g = 980.632 (1 - .002644 \cos 2\phi + .000007 \cos^2 2\phi) \text{ cm./sec.}^2,$

where  $\phi$  is the latitude, the numbers 978.046 and 980.632 giving the values of  $g$  at the equator and in latitude  $45^\circ$ \*

If we take  $g = 980.6 (1 - .002644 \cos 2\phi)$ , then the last expression for  $z$  becomes

$$z = \frac{k(1 + \alpha t)(1 + z/r)}{980.6\mu(1 - .002644 \cos 2\phi)} \left\{ \log_{10} \frac{h'}{h} + 2 \log_{10} \left( 1 + \frac{z}{r} \right) - \mu\theta(\tau' - \tau) \right\} \dots(4).$$

In these formulæ the value of  $k$ , as we have seen, depends on the amount of aqueous vapour in the air; but for dry air, taking  $p = k\rho(1 + \alpha t)$ , if the air is at  $0^\circ \text{C.}$  and a pressure of 760 mm. of mercury, the value of  $k$  is got from  $k\rho = p = 760g\sigma$ , where  $\sigma$  is the density of mercury. And taking  $\sigma/\rho = 10462$ , this makes

$$k = 760 \times 10462g \text{ mm.} \\ = 7951.12g \text{ metres.}$$

This would make the coefficient  $k/980.6\mu = 18308$  metres, but this neglects entirely the aqueous vapour, and a value for  $k$  that gives results more in accordance with observed facts is 7963.2g metres, making

$$k/980.6\mu = 18336 \text{ metres.}$$

In order to obtain  $z$  from the formula (4) an approximate value must be obtained first by neglecting  $z/r$  in the right-hand member of the equation; if this approximate value be then employed in the same expression, a more accurate value will result, and the same process may be repeated if necessary.

**127.** Other corrections are however necessary in order to render the determination of heights by the barometer very exact in practice; the value of  $k$  for instance is modified by the fact that the density of aqueous vapour at a given temperature and pressure is less than the density of dry air under the same circumstances,

\* *Handbuch der Physik*, A. Winkelmann, Leipzig 1908, p. 479. See also the Article *Figure of the Earth*, A. R. Clarke and F. R. Helmert, in the *Encycl. Brit. eleventh edition*.

and the proportion of aqueous vapour to dry air may be, and in general will be, different at the two stations.

Moreover, if the upper station be on the surface of the ground; the attraction of the portion of the earth which is above its mean level must be taken account of. The effect of this attraction is to increase the quantity  $gr^2/(r+z)^2$  by  $3gz/4r$  so that, at a height  $z$ , the force of gravity is measured by

$$\frac{gr^2}{(r+z)^2} + \frac{3gz}{4r},$$

or, approximately,  $g \left\{ 1 - \frac{5z}{4r} \right\}$  (Routh, *Analytical Statics*, II. p. 12); the equation for  $p$  will be in this case

$$dp = -g \left\{ 1 - \frac{5z}{4r} \right\} \rho dz,$$

and therefore, if the lower station be at the level of the sea,

$$k(1 + \alpha t) \log \frac{p'}{p} = gz \left( 1 - \frac{5z}{8r} \right)$$

or 
$$z = \frac{k(1 + \alpha t)}{g} \left( 1 + \frac{5z}{8r} \right) \log \frac{p'}{p}.$$

In place of the equation (2) of Art. (125) we shall have

$$\frac{p'}{p} = \left( 1 + \frac{5z}{4r} \right) \frac{1 - \theta \tau' h'}{1 - \theta \tau h},$$

and the final equation for  $z$  will be obtained by substituting in (4) of Art. (126)  $1 + \frac{5}{8}z/r$  for  $1 + z/r$ , observing that  $\log \left( 1 + \frac{5}{4}z/r \right)$  is approximately equal to  $2 \log \left( 1 + \frac{5}{8}z/r \right)$ .

We may note however that when  $z$  and  $r$  are measured in metres,  $z/r = \cdot 000000157z$  approximately, so that the error arising from neglecting  $z/r$  will generally be small.

A formula of this kind appears to have been given first by Laplace\*.

**128.** It must also be noticed that we have assumed the temperature of the mercury in the barometer to be the same as that of the air surrounding it; but in some cases, as for instance when

\* *Mécanique Céleste*, Livre x. chap. iv. Laplace's formula differing only in numerical coefficients from (4) Art. (126) remains the fundamental formula in this connection. It is quoted in Sir John Moore's *Meteorology* (1910), p. 149. For working formulæ for barometric corrections see any modern text-book on Physics, such as Chwolson, *Lehrbuch der Physik*, 1902, I. p. 443, and for numerical tables see *The Observer's Handbook* published by the Meteorological Office, 1908.

observations are made in a balloon, the barometer may not remain long enough in the same place to acquire the temperature of the air round it. The temperature of the mercury can, however, be observed by a thermometer, the bulb of which is placed in the cistern of the barometer, and the temperatures so obtained must be employed in the equation (2) of Art. (125).

**128 a. Convective Equilibrium.** An alternative hypothesis is that of the convective equilibrium of temperature in the atmosphere. As explained by Lord Kelvin\* “when all the parts of a fluid are freely interchanged and not sensibly influenced by radiation and conduction, the temperature of the fluid is said to be in a state of convective equilibrium.” This state implies that if equal masses of air at different levels were interchanged without gain or loss of heat, i.e. adiabatically, they would merely interchange pressure, density and temperature so that on the whole there would be no change. In this case therefore the equations are

$$dp = -g\rho dz \dots\dots\dots(1),$$

$$p = k\rho^{\gamma} \text{ and } p = K\rho T,$$

where  $T$  denotes absolute temperature at the height  $z$ ;

$$\therefore k\gamma\rho^{\gamma-2} d\rho = -g dz,$$

and by integration

$$\frac{k\gamma}{\gamma-1} \rho^{\gamma-1} = C - gz;$$

$$\therefore \frac{\gamma}{\gamma-1} \frac{p}{\rho} = C - gz;$$

$$\therefore \frac{\gamma}{\gamma-1} K(T - T_0) = -gz,$$

where  $T_0$  denotes the absolute temperature at sea-level.

$$\therefore \frac{T}{T_0} = 1 - \frac{\gamma-1}{\gamma} \cdot \frac{gz}{KT_0}.$$

And if  $H$  is the height of the homogeneous atmosphere

$$K\rho_0 T_0 = p_0 = g\rho_0 H;$$

$$\therefore \frac{T}{T_0} = 1 - \frac{\gamma-1}{\gamma} \cdot \frac{z}{H} \dots\dots\dots(2).$$

If in equation (1) we take  $gr^2/(r+z)^2$  instead of  $g$ , as before, we get on integration and substitution as above

$$\frac{T}{T_0} = 1 - \frac{\gamma-1}{\gamma} \cdot \frac{rz}{H(r+z)} \dots\dots\dots(3).$$

\* *Collected Papers*, Vol. III. p. 255.

129. The two following problems are illustrative of the principles of this chapter.

1) A piston without weight fits into a vertical cylinder, closed at its base and filled with atmospheric air, and is initially at the top of the cylinder; water being poured slowly on the top of the piston, find how much can be poured in before it will run over.

Let  $a$  be the height of the cylinder, and  $z$  the depth to which the piston will sink; then in the position of equilibrium the pressure of the air in the cylinder is  $\Pi + g\rho z$ , where  $\Pi$  is the atmospheric pressure, and  $\rho$  the density of water: but

this pressure:  $\Pi = a : a - z$ ;

$$\therefore \frac{\Pi a}{a - z} = \Pi + g\rho z.$$

Let  $h$  be the height of the water-barometer,

$$\therefore \Pi = g\rho h,$$

$$ha = (a - z)(h + z),$$

and

$$z = 0 \text{ or } a - h.$$

Unless then the height of the cylinder is greater than  $h$ , no water can be poured in, for, even if the piston be forced down and water then poured on it, the pressure of the air beneath will raise the piston.

The negative solution, when  $a < h$ , can however be explained as the solution of a different problem leading to the same algebraic equation. Suppose the cylinder to be continued above the piston, and let it be required to raise the piston through a space  $z$  by a force which shall be equal to the weight of the cylindrical space  $z$  of water.

This leads to the equation

$$\frac{\Pi - g\rho z}{\Pi} = \frac{a}{a + z},$$

or

$$z = h - a.$$

(2) To determine the motion of a balloon on the supposition that the mass of air displaced by it in any position is homogeneous, and that the temperature throughout is constant.

Let  $z$  be the height of the centre of mass of the balloon,  $m$  its mass,  $V$  its volume, and  $\rho$  the density of the air at the height  $z$ ; then the equation which determines the motion is

$$m \frac{d^2z}{dt^2} = g' \rho V - mg',$$

where

$$g' = g \frac{r^2}{(r + z)^2}.$$

But from the equations  $d\rho = -g' \rho dz$  and  $p = k\rho$ , we obtain

$$\rho = \Pi e^{-\frac{grz}{k(r+z)}},$$

and therefore

$$m \frac{d^2z}{dt^2} = \frac{\Pi V g r^2}{k(r+z)^2} e^{-\frac{grz}{k(r+z)}} - mg \frac{r^2}{(r+z)^2};$$

from which, putting  $m = \sigma l$ , multiplying by  $2 \frac{dz}{dt}$ , and integrating,

$$\sigma \left( \frac{dz}{dt} \right)^2 = C - 2\Pi e^{-\frac{grz}{k(r+z)}} + \frac{2\sigma gr^2}{r+z};$$

initially

$$0 = C - 2\Pi + 2\sigma gr,$$

$$\therefore \sigma \left( \frac{dz}{dt} \right)^2 = 2\Pi \left\{ 1 - e^{-\frac{grz}{k(r+z)}} \right\} - \frac{2\sigma gr^2}{r+z}.$$

The greatest height of the balloon is given by putting

$$\frac{dz}{dt} = 0,$$

and, if the mean density of the balloon differ very little from that of the air,  $z/r$  will be small, and an approximate value may be found.

### EXAMPLES

1. If the specific gravity of air be .0013, that of mercury 13.59, and if the height of the barometer be 30 inches, prove that the numerical value of  $k$  is about 836300, a foot and a second being units of space and time.

2. The weight of 1 litre of dry air at  $15.5^\circ \text{C}$ . when the height of the barometer is 760 mm. is 1.23 grammes. The pressure of aqueous vapour at this temperature is 12.6 mm. of mercury, and its density is to that of dry air at the same temperature and pressure as 5 to 8. Find the weight of a litre of air when saturated with aqueous vapour at the above temperature and pressure.

3. A faulty barometer indicated 29.2 and 30 inches when the indications of a correct instrument were 29.4 and 30.3 inches respectively; find the length of tube which the air in the tube would fill under the pressure of 30 inches.

4. The barometer standing at 30 inches, a cubic yard of atmospheric air is compressed into a vessel containing a cubic foot; find approximately the numerical measure of the energy stored up, the specific gravity of mercury being 13.596 referred to water, of which a cubic inch weighs 252.77 grains.

5. The readings of a perfect mercurial barometer are  $a$  and  $\beta$ , while the corresponding readings of a faulty one, in which there is some air, are  $\alpha$  and  $b$ ; prove that the correction to be applied to any reading  $c$  of the faulty barometer is

$$\frac{(a-\alpha)(\beta-b)(\alpha-b)}{(a-c)(\alpha-\alpha) - (b-c)(\beta-b)}.$$

6. If a thermometer, plunged incompletely in a liquid whose temperature is required, indicate a temperature  $t$ , and  $\tau$  be that of the air, the column not immersed being  $m$  degrees, prove that the correction to be applied is

$$\frac{m(t-\tau)}{6840 + \tau - m},$$

1/6840 being the expansion of mercury in glass for  $1^\circ$  of temperature, assuming that the temperature of the mercury in each part is that of the medium which surrounds it.

7. A closed vertical cylinder of unit sectional area contains a piston, weight  $W$ . The piston is originally halfway up the cylinder, and the space above and below is filled with saturated air. On being left to itself the piston sinks to half its former height; prove that the tension of the saturated vapour is  $3W - 4\Pi$  where  $\Pi$  is the pressure of the atmosphere: the temperature being supposed the same at the end and beginning of the process.

8. A vertical barometer tube is constructed, of which the upper portion is closed at the top, and has a sectional area  $a^2$ , the middle portion is a bulb of volume  $b^3$ , and the lower portion has a section  $c^2$ , and is open at the bottom; the mercury fills the bulb and part of the upper and lower portions of the tube, and is prevented from running out below by means of a float against which the air presses; the upper part of the tube is a vacuum: find the change of position of the upper and lower ends of the mercurial column, due to a given alteration of the pressure of the atmosphere.

Shew also that, if the whole volume of the mercury in the instrument be  $c^2H$ , where  $H$  is the height of the barometer, the upper surface will be unaffected by changes of temperature.

9. A cylindrical diving-bell sinks in water until a certain portion  $V$  remains occupied by air, and in this position a quantity of air, whose volume under the atmospheric pressure was  $2V$ , is forced into it. Shew how far the bell must sink in order that the air may occupy the same space as in the first position.

Find also the condition that when the air is forced in at the first position no air may escape from beneath the bell.

10. A vessel, in the form of the surface generated by the revolution about its axis of an arc of a parabola terminated by the vortex, is immersed, mouth downwards, in a trough of mercury; shew that the pressure of the air contained in the vessel varies inversely as the square of the distance of the vertex of the vessel from the surface of the mercury within it. Supposing the length of the axis of the vessel to be to the height of the barometer as 45 is to 64, find the depth of the surface of the mercury within the vessel, when the whole vessel is just immersed.

11. A piston without weight fits into a vertical cylinder, closed at its base and filled with air, and is initially at the top of the cylinder; if water be slowly poured on the top of the piston, shew that the upper surface of the water will be lowest when the depth of the water is  $\sqrt{(ah) - h}$ , where  $h$  is the height of the water-barometer, and  $a$  the height of the cylinder.

12. The barometer stands at 29.88 inches, and the thermometer is at the Dew Point: a barometer and a cup of water are placed under a receiver, from which the air is removed, and the barometer then stands at .36 of an inch; find the space which would be occupied by a given volume of the atmosphere, if it were deprived of its vapour without changing its pressure or temperature.

13. A straight tube, closed at one end and open at the other, revolves with a constant angular velocity about an axis meeting the tube at right angles; neglecting the action of gravity, find the density of the air within the tube at any point.

14. A bent tube of uniform bore, the arms of which are at right angles, revolves with constant angular velocity  $\omega$  about the axis of one of its arms, which is vertical and has its extremity immersed in water. Prove that the height to which the water will rise in the vertical arm is

$$\frac{\Pi}{g\rho} \left( 1 - e^{-\frac{\omega^2 a^2}{2k}} \right),$$

$a$  being the length of the horizontal arm,  $\Pi$  the atmospheric pressure, and  $\rho$  the density of water, and  $k$  the ratio of the pressure of the atmosphere to its density.

15. A thin uniform circular tube of radius  $a$  contains air and rotates with angular velocity  $\omega$  about an axis in its plane, distant  $c$  from the centre; find

the pressure at any point neglecting the weight of the air. If  $c$  is less than  $a$ , and if  $p$  and  $p'$  are the greatest and least pressures, prove that

$$\log \frac{p}{p'} = \frac{\omega^2}{2k} (a+c)^2.$$

16. Prove that for rough purposes the difference of the logarithms of the heights of the barometer multiplied by 10000 gives the difference of the heights of two stations in fathoms.

17. Two non-conducting vessels, of volumes  $v$  and  $v'$ , contain atmospheric air at pressures  $p$  and  $p'$ , at the temperatures  $T$  and  $T'$ ; if these masses of air be mixed together in a non-conducting vessel of volume  $V$ , find the pressure of the mixture.

18. Two bulbs containing air are connected by a horizontal glass tube of uniform bore, and a bubble of liquid in this tube separates the air into two equal quantities. The bubble is then displaced by heating the bulbs to temperatures  $t$  degrees and  $t'$  degrees: prove that, if the temperature of each bulb be decreased  $\tau$  degrees, the bubble will receive an additional displacement which bears to the original displacement the ratio of

$$2a\tau : 2 + a(t+t' - 2\tau),$$

where  $a$  is the coefficient of expansion.

19. An elastic spherical envelope is surrounded by air saturated with vapour; when the air within it is at a pressure of two atmospheres it is found that its radius is twice its natural length, and again the radius is three times its natural length when the envelope contains 77 times as much air as it would if open to the air; assuming that the tension at any point varies as the extension of the surface, prove that  $\frac{1}{25}$  of the pressure of the air is due to the vapour it contains.

20. A conical shell, vertical angle  $\pi/2$ , and height  $H$ , can hold double its own weight of water. It is inverted and immersed, axis vertical, in a mass of water. The water is now made to rotate with angular velocity  $(7g^2/2H^3)^{1/2}$  and the cone sinks till its vertex lies in the surface: prove that the height of the water-barometer is to that of the cone as  $3 : \sqrt{28}$ .

21. A small balloon containing air is immersed in water and has 100 grains of lead attached to it, the envelope of the balloon being of the same density as the water. If at the temperature of the water and the pressure of the atmosphere the balloon contain 1 cub. inch of air, find the depth to which it must be immersed in the water to be in a position of unstable equilibrium when the height of the water-barometer is 33 feet; it being given that the density of air : that of water : that of lead = 1 : 800 : 9120.

22. A cup is formed out of a uniform solid paraboloid, by removing half the volume, so that the inner boundary is an equal coaxial paraboloid with its vertex at the focus of the former one. The cup is immersed in vacuo in a fluid, vertex upwards and axis vertical, and gas is forced in from below till the vertex rises to the surface: if the water be now halfway up the inner boundary of the cup, prove that the density of the fluid is  $\frac{1}{3}$  that of the paraboloid.

23. If the pressure of the air varied as the  $(1 + 1/m)^{\text{th}}$  power of the density, show that, neglecting variations of temperature and gravity, the height of the atmosphere would be equal to  $(m+1)$  times the height of the homogeneous atmosphere.

24. A piston of weight  $w$  rests in a vertical cylinder of transverse section  $k$ , being supported by a depth  $a$  of air. The piston rod receives a vertical blow  $P$ , which forces the piston down through a distance  $h$ : prove that

$$(w + \Pi k) \left\{ h + a \log \left( 1 - \frac{h}{a} \right) \right\} + \frac{gP^2}{2w} = 0,$$

$\Pi$  being the atmospheric pressure.

25. If a spherical balloon of radius  $r$ , containing a quantity of gas of density  $\sigma$  at the pressure  $p_0$  of the atmosphere on the surface of the earth, be just able to sustain a tension  $T$ , shew that it will burst when its velocity is given by

$$\frac{v^2}{2} = \frac{2T}{\sigma r} + k \log \left( 1 - \frac{2T'}{p_0 r'} \right)$$

where the resistance to the motion of the balloon is neglected.

26. Supposing the atmosphere to fill the whole of space and to be of uniform temperature throughout, prove that the ratio of the density of the atmosphere at the surface of Mars to that at the Earth will be  $e^{-.576}$  nearly; it being given that the density of Mars is the same as that of the Earth, that his radius is one-half the Earth's radius, which is 6366800 metres, and that the atmospheric pressure on the Earth is 1033 grams per sq. cm., while the mass of a cubic cm. of air is .001247 grams.

27. If after graduation a small volume  $v$  of air is allowed into the vacuum above the mercury in a barometer, shew that the necessary correction of any observed reading  $h$ , the temperature remaining unaltered, is

$$\bar{c} - (1 - \nu) \frac{h}{h - \bar{H}} \cdot \frac{v}{a'}$$

where  $a$  is the area of the section of the tube,  $\frac{a}{n}$  that of the basin, and  $\bar{c}$  is the length of the apparent vacuum corresponding to another observed reading  $\bar{H}$  of the faulty barometer.

28. Prove that, if the temperature in the atmosphere fall uniformly with the height ascended, the height of a station above sea level is given by

$$z = a \{ 1 - (h/h_0)^m \},$$

where  $h$ ,  $h_0$  are the readings of the barometer at the station and at sea level respectively, and  $a$ ,  $m$  are constants.

29. Shew that in an atmosphere in "convective equilibrium" the temperature would diminish upwards with a uniform gradient; and calculate this gradient in degrees centigrade per 100 metres, assuming the following data (in C.G.S. units):

height of barometer	= 76.0,
temperature (absolute)	= 272° C.,
density of air	= .00129,
density of mercury	= 13.60,
ratio of specific heats ( $\gamma$ )	= 1.42.

## CHAPTER VIII

### THE TENSION OF FLEXIBLE SURFACES

**130.** THE general problem of the equilibrium of flexible surfaces was considered by Lagrange, *Mécanique Analytique*, Tom. I., and also more fully by Poisson, *Mémoires de l'Institut*, 1812; it is proposed in this chapter to discuss one class of the questions which arise out of the general case, those namely which have reference to the action of fluids upon flexible surfaces.

The pressure of a fluid at rest being normal to any surface with which it is in contact, we have, in fact, to consider the equilibrium of flexible surfaces at rest under the action of normal pressures, and of the tensions at their bounding lines.

For the sake of generality the term 'flexible surface' is employed as the representative of substances, such as cloth and thin paper, which do not offer any sensible resistance to bending, and which, when bent or twisted, do not tend to return to their original form. Perfectly flexible surfaces, whether extensible or inextensible, are therefore to be looked upon as inelastic.

In the following articles we shall suppose that the stress between any two portions of a flexible surface is wholly tangential to the surface.

#### *Measure of Tension.*

Conceive a flexible and inelastic surface, extensible or inextensible, in a state of tension, and let  $QPQ'$  be a small arc of the section through  $P$  made by a normal plane; then if  $t \cdot QQ'$  be the resultant action, perpendicular to  $QQ'$  in the tangent plane, between the portions of surface bounded by the line  $QQ'$ ,  $t$  is the measure of the tension at  $P$ ; in other words,  $t$  is the rate of tension at  $P$ , or the force which would be exerted on a section of the substance, the length of which is unity, in the same state of tension throughout as the surface at  $P$ .

In general the stress between the portions of surface separated by  $QQ'$  will not be perpendicular to  $QQ'$ , and will therefore be the resultant of the tension  $t \cdot QQ'$  and of a force  $\tau \cdot QQ'$  tangential to the curve  $QQ'$ ,  $\tau$  being a quantity of the same kind as  $t$  and measured in the same way.

✓131. A vessel in the form of a right circular cylinder, the curved surface of which is flexible, contains fluid; the axis of the cylinder being vertical, it is required to find the relation between the pressure and tension at any point.

Let  $PQ$  be a small portion of the surface contained between two planes perpendicular to the axis and two generating lines of the cylinder.

Let  $t$  be the horizontal tension and  $p$  the pressure, at any point of  $PQ$ ; then the equilibrium of the element  $PQ$  of the surface will be maintained by the normal pressure of the fluid,  $pPP'.PQ$ , the tangential forces  $tPP'$  and  $tQQ'$ , and by the vertical tensions on  $PQ$  and  $P'Q'$ , if there be any tension in the vertical direction.

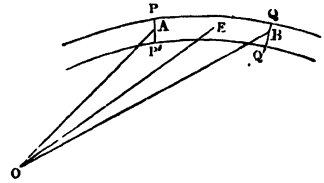

Hence, resolving the forces in the direction of the normal  $OE$ , drawn to the middle point  $E$ ,

$$\begin{aligned} p \cdot PP' \cdot PQ &= 2tPP' \sin\left(\frac{1}{2}POQ\right), \\ &= 2tPP' \frac{1}{2} \frac{PQ}{r}, \text{ if } r \text{ be the radius,} \end{aligned}$$

or  $t = pr$ .

132. If fluid at rest be contained in a flexible cylindrical surface of any form, the tension at any point of a section perpendicular to the axis of the cylinder is the same.

Let  $PQ$  (figure, Art. 131), be an element of the surface,  $O$  the centre of curvature at  $A$ ,  $t$  the tension at  $A$ ,  $t + \delta t$  at  $B$ , and  $\delta\phi$  the angle between the tangents at  $A$  and  $B$ .

Also, let  $\delta\psi$  be the inclination to  $OA$  of the direction of the fluid pressure on  $PQ$ , which must lie between  $OA$  and  $OB$ .

Then, resolving along the tangent at  $A$ ,

$$\begin{aligned} (t + \delta t) \cos \delta\phi - t &= pAB \sin \delta\psi \\ &= pr\delta\phi \sin \delta\psi, \end{aligned}$$

if  $r$  be the radius of curvature at  $A$ .

Hence, ultimately, when  $\delta\phi$  vanishes,

$$\frac{dt}{d\phi} = 0,$$

and, as this is the case at every point of the section, it follows that  $t$  is constant.

By resolving the forces in the direction  $OE$ , we shall obtain, as in the previous article, the relation

$$t = pr,$$

between the tension perpendicular to the generating line, the pressure, and the curvature, at any point of the surface.

Taking  $t$  constant, the equation  $pr = t$  determines the pressure at any point if the surface is given.

If the forces acting on the fluid are given, so that  $p$  is a known function of the co-ordinates of a point in the fluid, the same equation determines the form assumed by the flexible surface.

### The Lintearia and the Elastica.

133. The Lintearia is the curve formed by pouring water upon a rectangular piece of thin cloth, the ends of which are supported horizontally, while the water is prevented from escaping at the sides.

Thus, if the ends  $AB, CD$ , of the cloth or membrane be fastened to the sides of a box, and if the sides  $AD, BC$  fit the box closely and water be

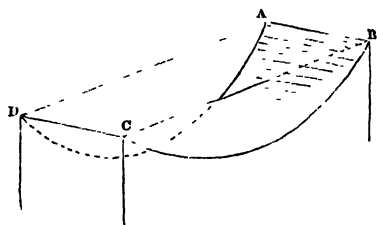

pour ed in, the cross section of the cloth by a vertical plane parallel to  $AD$  or  $BC$  is the Lintearia.

The pressure being normal, the tension of the cloth is constant, and therefore, if  $r$  be the radius of curvature at  $P$ , and  $BC$  the surface of the water (see figure, next page),

$$g\rho PL \cdot r \text{ is constant.}$$

Assuming  $g\rho c^2$  to represent the tension, and taking  $PN = y$ , we obtain

$$\frac{c^2}{r} = PL = h - y.$$

Hence 
$$\frac{c^2}{r^2} \frac{dr}{d\phi} = \frac{dy}{d\phi} = r \sin \phi,$$

and 
$$\therefore \frac{c^2}{2r^2} = \cos \phi - \cos \alpha,$$

if  $\alpha$  be the deflection at  $B$ ,

or 
$$\sqrt{2} \frac{ds}{d\phi} = \frac{c}{\sqrt{\cos \phi - \cos \alpha}},$$

the intrinsic equation.

Putting  $\sin \frac{\alpha}{2} = k$ , and  $\sin \frac{\phi}{2} = k \operatorname{sn} u$

this becomes 
$$ds = \frac{cd\phi}{2\sqrt{\sin^2 \frac{\alpha}{2} - \sin^2 \frac{\phi}{2}}}$$

$$= \frac{ck \operatorname{cn} u \operatorname{dn} u du}{k\sqrt{1 - k^2 \operatorname{sn}^2 u} \sqrt{1 - \operatorname{sn}^2 u}}$$

$$= cdu.$$

$\therefore s = cu + \text{constant},$

or if we measure  $s$  from the lowest point

$s = cu \dots\dots\dots(1).$

Then the depth  $PL = h - y = c^2/r,$   
 $= c\sqrt{2\sqrt{\cos \phi} - \cos \alpha},$   
 $= 2ck\sqrt{1 - \operatorname{sn}^2 u},$

or  $h - y = 2ck \operatorname{cn} u \dots\dots\dots(2).$

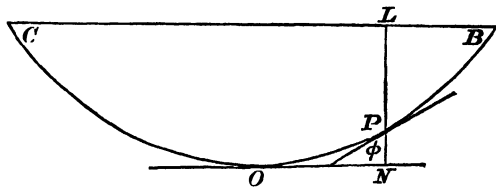

Again if  $ON = x,$

we have  $\frac{dx}{ds} = \cos \phi = 1 - 2k^2 \operatorname{sn}^2 u.$

$\therefore x = c \int_0^u (1 - 2k^2 \operatorname{sn}^2 u) du$

or  $x = c \{2E(\operatorname{am} u) - u\} \dots\dots\dots(3),$

where  $E$  is the elliptic integral of the second kind.

The terminal conditions are that  $x, y, s$  all vanish together when  $u = 0$ , and using these values in equation (2) we get  $h = 2ck$ ; also if  $x = a$  and  $s = l$  when  $y = h$ , then substituting in equation (2) we get  $0 = \operatorname{cn} u$ , so that the corresponding value of  $u$  is  $K$  the real quarter period of the elliptic function, and therefore from (1) and (3) we have

$l = cK,$

and  $a = c \{2E(\operatorname{am} K) - K\}.$

The curve is therefore given by equations (1), (2), (3), subject to the foregoing relations between the constants.

**134.** The *Elastica* is the curve formed by an elastic rod when bent, and is identical with the *Lintearia*.

Taking  $BOC$  as the rod, suppose the equilibrium maintained by forces at  $B$  and  $C$  in opposite directions.

The bending moment at  $P$  is proportional to the curvature\* and therefore, considering the equilibrium of the portion  $BP$ , and taking moments about  $P$ , it follows that the curvature at  $P$  varies as  $PL$ , so that

$$r \cdot PL = c^3,$$

and the *Elastica* is therefore identical with the *Lintearia*.

**135.** The *Elastica*† may have any number of convolutions, as in the appended figures,

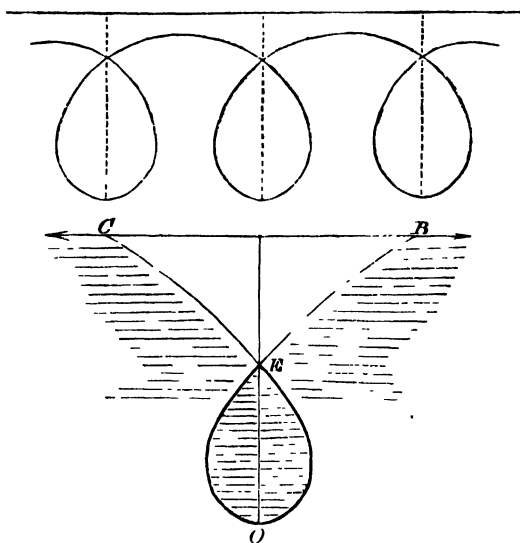

and the *Lintearia* can be made to have convolutions by a proper adjustment of the water level and the water pressure.

Thus, if we imagine  $BC$  to be the water surface, and if arrangements be made to let the water fill the space  $OE$ , and press upwards on the portions  $BE$ ,  $CE$ , we have a *Lintearia* identical with an *Elastica* of one convolution.

\* Routh, *Analytical Statics*, II. p. 269, or Kelvin and Tait, *Natural Philosophy*, § 591.

† For a full discussion of the *Elastica*, see Kelvin and Tait, *Natural Philosophy*, § 611; Love, *The Mathematical Theory of Elasticity*, p. 384, or L. Levy, *Précis Élémentaire de la Théorie des Fonctions Elliptiques*, p. 112.

If we imagine that  $BC$  touches the bent rod at  $B$  and  $C$ , necessitating, as will be seen, an infinite length of rod, and if, as before, we measure the deflection from the tangent at  $O$ ,

$$r = \infty, \text{ when } \phi = \pi,$$

and therefore

$$\frac{c^2}{2r^2} = 1 + \cos \phi, \text{ or } \frac{ds}{d\phi} = \frac{c}{2 \cos \frac{\phi}{2}}.$$

Measuring  $s$  from  $O$ , this leads to

$$s = c \log \tan \left( \frac{\pi}{4} + \frac{\phi}{4} \right).$$

It will be seen hereafter that this is the Capillary curve.

**136.** We may also obtain the equations of the *Lintearia*\* in terms of Weierstrass's Elliptic Functions. Thus, from Art. (133) we have

$$\begin{aligned} \frac{h-y}{c^2} = \frac{1}{r} &= \frac{\frac{d^2y}{dx^2}}{\left\{ 1 + \left( \frac{dy}{dx} \right)^2 \right\}^{\frac{3}{2}}} = \frac{p \frac{dp}{dy}}{(1+p^2)^{\frac{3}{2}}}. \\ \therefore \frac{2hy-y^2}{2c^2} = 1 - \frac{1}{\sqrt{1+p^2}} &= 1 - \cos \phi \quad \dots\dots\dots(1), \end{aligned}$$

so that

$$\frac{dx}{ds} = 1 - \frac{2hy-y^2}{2c^2},$$

and

$$\frac{dx}{dy} = \frac{2c^2 + y^2 - 2hy}{\sqrt{\{(2hy-y^2)(4c^2-2hy+y^2)\}}},$$

Put

$$2hy-y^2 = z \text{ so that } 2(h-y)dy = dz.$$

$$\therefore \frac{dx}{dz} = \frac{2c^2-z}{\sqrt{\{4z(z-4c^2)(z-h^2)\}}},$$

and let

$$z = v + \frac{1}{3}(4c^2+h^2),$$

so that

$$dv = \sqrt{\left[ 4 \left\{ v + \frac{1}{3}(4c^2+h^2) \right\} \left\{ v - \frac{1}{3}(8c^2-h^2) \right\} \left\{ v + \frac{1}{3}(4c^2-2h^2) \right\} \right]}.$$

Now let

$$u = \int \frac{dv}{\sqrt{\{4(v-e_1)(v-e_2)(v-e_3)\}}},$$

where

$$e_1 = \frac{1}{3}(8c^2-h^2), \quad e_2 = -\frac{1}{3}(4c^2-2h^2), \quad e_3 = -\frac{1}{3}(4c^2+h^2),$$

\* The investigation of the equation of the *Lintearia* was first effected by James Bernoulli.

so that since from (1)  $h = 2c \sin \frac{\alpha}{2}$ ,  $h^2 < 4c^2$ ,

and  $\therefore e_1 > e_2 > e_3$ .

Hence  $v = \wp(u + \epsilon)$  where  $\epsilon$  is a constant.

Now  $0 \leq y \leq h$  so that  $0 \leq z \leq h^2$ ,

and  $\therefore -\frac{1}{3}(4c^2 + h^2) \leq v \leq -\frac{1}{3}(4c^2 - 2h^2)$ ,

that is  $e_3 \leq v \leq e_2$ .

Hence taking  $u$  to be real, the imaginary part of  $\epsilon$  must be the imaginary half period  $\omega_3$ , and its real part may be taken as zero by suitable choice of the lower limit for  $u$ .

$$\therefore v = \wp(u + \omega_3),$$

so that since  $\frac{dx}{dv} = \frac{-(\frac{1}{2}e_2 + v)}{\sqrt{\{4(v - e_1)(v - e_2)(v - e_3)\}}}$ ,

$$\therefore dx = -\{\frac{1}{2}e_2 + \wp(u + \omega_3)\} du,$$

and  $x = C - \frac{1}{2}e_2u + \zeta(u + \omega_3)$ ,

where  $\zeta$  is Weierstrass's Zeta-Function.

Also when  $x = 0$  then  $z = 0$  and  $v = e_3 = \wp(\omega_3)$  so that  $u = 0$  and  $C = -\zeta(\omega_3)$ , hence

$$x = \zeta(u + \omega_3) - \zeta(\omega_3) - \frac{1}{2}e_2u \dots\dots\dots(2).$$

and since  $2hy - y^2 = z = v - e_3$ , therefore we have

$$2hy - y^2 = \wp(u + \omega_3) - e_3; \dots\dots\dots(3).$$

Again

$$\frac{ds}{dy} = \left\{1 + \left(\frac{dx}{dy}\right)^2\right\}^{\frac{1}{2}} = \sqrt{\{(2hy - y^2)(4c^2 - 2hy + y^2)\}},$$

so that with the same substitutions

$$\frac{ds}{dz} = \frac{2c^2}{\sqrt{\{4z(z - 4c^2)(z - h^2)\}}},$$

and  $\frac{ds}{dv} = \frac{2c^2}{\sqrt{\{4(v - e_1)(v - e_2)(v - e_3)\}}}$ .

Hence  $\frac{ds}{dv} = 2c^2 \frac{du}{dv}$ ,  
 $\therefore s = 2c^2u \dots\dots\dots(4)$ ,

provided we measure  $s$  from  $O$  where, as above,  $u$  vanishes.

137. If  $x = a$ , and  $s = l$  when  $y = h$ , then for this value we have  $z = h^2$  and  $v = -\frac{1}{3}(4c^2 - 2h^2) = e_2$ . Therefore  $\varphi(u + \omega_2) = e_2$ , so that the corresponding value of  $u$  must be  $\omega_1$ , and the constants and periods are connected by the relations

$$\begin{aligned} a &= \zeta(\omega_2) - \zeta(\omega_1) - \frac{1}{2} e_2 \omega_1, \\ l &= 2c^2 \omega_1. \end{aligned}$$

We have drawn the figures for the case in which the water is filled up to the level  $BC$ , but, if a smaller quantity of water is poured in, the portions of cloth not in contact with the water will be plane, and the value of  $h$  will be the depth of the vertex below the surface of the water.

138. **Tensions and Tangential actions.** Considering the equilibrium of a plane flexible membrane, the stress along any line, that is, the action between the contiguous portions of the surface bounded by that line, is in general oblique to the line, and is therefore represented by a tension  $t$  and a tangential action  $\tau$ ; we shall now shew that for any two directions, at right angles to each other,  $\tau$  is the same, and that there are two directions for which  $\tau$  vanishes.

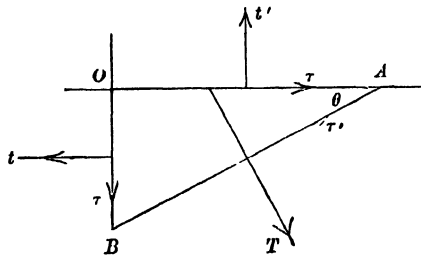

Taking any small square element of the surface, the tangential actions  $\tau \delta s$  and  $(\tau + \delta \tau) \delta s$  on a pair of opposite sides form ultimately a couple  $\tau \delta s^2$ , if  $\delta s$  be a side of the element; and, since this must be balanced by the other couple,  $\tau' \delta s^2$ , if  $\tau'$  be the tangential action in the direction at right angles, it follows that  $\tau$  and  $\tau'$  are equal.

Now take a small triangular element,  $OAB$ , right-angled at  $O$ , and represent the stresses as in the figure.

Resolving parallel to  $BA$ , we obtain

$$\tau'AB + \tau OA \cos \theta + t'OA \sin \theta = tOB \cos \theta + \tau OB \sin \theta,$$

$$\therefore 2\tau' = (t - t') \sin 2\theta - 2\tau \cos 2\theta,$$

and  $\tau'$  vanishes when

$$(t - t') \tan 2\theta = 2\tau,$$

giving two directions at right angles.

**139.** If in the figure we assume that  $OA$  and  $OB$  are the directions of zero tangential action, and if we resolve in the directions perpendicular and parallel to  $BA$ , we shall obtain the equations

$$T = t \sin^2 \theta + t' \cos^2 \theta,$$

$$\tau' = (t - t') \sin \theta \cos \theta.$$

The quantities  $t$  and  $t'$  are now the greatest and least, or the least and greatest tensions, and we shall therefore call them the Principal Tensions.

**140.** If  $\phi$  be the inclination to  $OA$  of the resultant stress,  $R.AB$ , upon  $AB$ ,

$$\tan \phi = \frac{t' \cdot OA}{t \cdot OB} = \frac{t'}{t} \cot \theta,$$

$$\therefore \tan \phi \tan \theta = \frac{t'}{t}.$$

Also

$$R^2.AB^2 = t^2.OB^2 + t'^2.OA^2,$$

$$\therefore R^2 = t^2 \sin^2 \theta + t'^2 \cos^2 \theta,$$

and, eliminating  $\theta$ , we obtain the relation

$$\frac{1}{R^2} = \frac{\cos^2 \phi}{t^2} + \frac{\sin^2 \phi}{t'^2}.$$

If then  $t$  and  $t'$  are the principal tensions at the point  $O$ , in the directions  $OA$  and  $OB$ , and if  $\theta$  is the inclination of  $OE$  to  $OA$ , the direction  $OF$  of the stress across  $OE$  is given by the equation

$$\tan \phi \tan \theta = \frac{t'}{t},$$

and the magnitude of the stress, per unit of length, is represented by the radius, in the direction  $OF$ , of an ellipse, the semi-axes of which are represented by the principal tensions.

**141. Conjugate stresses.** If the stress across  $OE$  is in the direction  $OF$ , the stress across  $OF$  is in the direction  $OE$ .

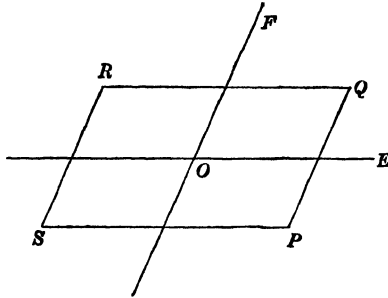

For, if we consider the equilibrium of an element in the form of a parallelogram  $PQRS$ , the sides of which are parallel to  $OE$  and  $OF$ , the stresses on  $PS$  and  $QR$  equilibrate, and therefore it follows that the stresses on  $PQ$  and  $RS$  equilibrate, and are therefore in the directions  $OE$  and  $EO$ .

**142.** If  $R$  and  $R'$  are the conjugate stresses across  $OE$  and  $OF$ , and if  $\theta$  and  $\phi$  are the inclinations of  $OE$  and  $OF$  to the direction of the principal tension  $t$ , we have from Art. (140), the equations

$$\frac{1}{R^2} = \frac{\cos^2 \phi}{t^2} + \frac{\sin^2 \phi}{t'^2},$$

$$\frac{1}{R'^2} = \frac{\cos^2 \theta}{t^2} + \frac{\sin^2 \theta}{t'^2},$$

where  $\theta$  and  $\phi$  are connected by the relation

$$\tan \phi \tan \theta = \frac{t'}{t}.$$

Eliminating  $\theta$  and  $\phi$ , we find that

$$RR' = tt',$$

so that, at any point, the product of two conjugate stresses is constant, and equal to the product of the principal tensions.

**143.** The same results can be obtained by writing down the conditions of equilibrium of two elemental triangles  $OAB$ ,  $OA'B'$ , where  $AB$  and  $A'B'$  are parallel to  $OE$  and  $OF$ .

We should thus obtain the equations

$$R \cos \phi = t \sin \theta, \quad R \sin \phi = t' \cos \theta,$$

$$R' \cos \theta = t \sin \phi, \quad R' \sin \theta = t' \cos \phi,$$

from which we can obtain the relations already given.

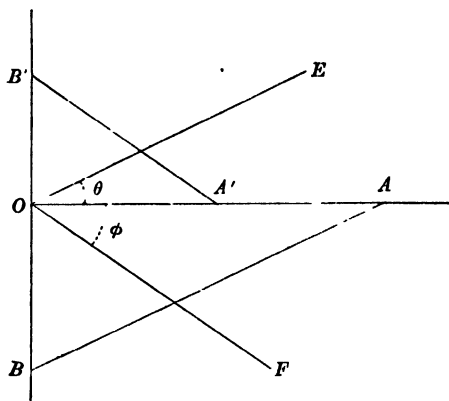

**144.** If now we take the case of a flexible membrane exposed to fluid pressure, and consider the equilibrium of a small element of the membrane, the results of the three preceding articles are at once applicable to the case, for in the limit the components of normal pressure disappear in comparison with the tangential action.

✓ **145. Principal tensions.** *A flexible surface of any form is exposed to the action of fluid; required to find the relation between the pressure, principal tensions, and the curvatures in the directions of these tensions, at any point\*.*

Let  $Q, Q'$ , be points contiguous to  $P$ , on the lines of principal tension  $PQ, PQ'$ , through  $P$ ; draw normal planes through  $Q$  and  $Q'$ ,

\* The student must be guarded against the idea that there is any connection between principal tensions and principal curvatures.

For instance, imagine a membrane folded round a cylinder, and draw a number of helical lines of the same pitch on the membrane.

The membrane can be tightened in the directions of these lines, which will become the directions of greatest tension, the perpendicular tension being zero, and the stress along a generating line being oblique to that line.

perpendicular to the lines  $PQ$ , and  $PQ'$ , cutting the surface in the arcs  $AB$ ,  $AD$ , and let  $BC$ ,  $CD$ , be the arcs of sections made by normal planes through contiguous points in  $Q'P$ ,  $QP$ , produced.

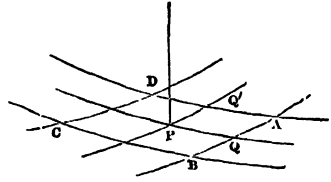

The element  $BD$  is kept at rest by the tangential forces  $tAB$ ,  $tCD$ ,  $t'AD$ ,  $t'BC$ , and the normal force,  $p \cdot AB \cdot BC$ .

Let  $r$ ,  $r'$ , be the radii of curvature at  $P$  of the curves  $PQ$ ,  $PQ'$ ; then, resolving along the normal at  $P$ , we have ultimately

$$p \cdot AB \cdot BC = 2tAB \frac{\frac{1}{2}AD}{r} + 2t'BC \frac{\frac{1}{2}AB}{r'}$$

and 
$$\therefore p = \frac{t}{r} + \frac{t'}{r'}$$

If the nature of the surface be such that  $t' = t$ , the above equation is

$$\frac{p}{t} = \frac{1}{r} + \frac{1}{r'} = \frac{1}{\rho} + \frac{1}{\rho'}$$

if  $\rho$  and  $\rho'$  are the principal radii of curvature.

Hence if  $z = f(x, y)$  is the equation to the surface, it follows that

$$\begin{aligned} \frac{p}{t} \cdot \left\{ 1 + \left( \frac{\partial z}{\partial x} \right)^2 + \left( \frac{\partial z}{\partial y} \right)^2 \right\}^{\frac{1}{2}} \\ = \left\{ 1 + \left( \frac{\partial z}{\partial y} \right)^2 \right\} \frac{\partial^2 z}{\partial x^2} - 2 \frac{\partial z}{\partial x} \frac{\partial z}{\partial y} \frac{\partial^2 z}{\partial x \partial y} + \left\{ 1 + \left( \frac{\partial z}{\partial x} \right)^2 \right\} \frac{\partial^2 z}{\partial y^2}; \end{aligned}$$

which is the equation obtained by Lagrange and Poisson.

**146. Tensions in any directions.** If the directions of  $t$  and  $t'$  are not those of principal tensions the tangential action will appear in the equation.

Taking any point  $O$  on the surface, two directions  $OA$ ,  $OB$  at right angles to each other, let  $t$ ,  $t'$  be the tensions in these directions, and  $T'$ ,  $T$  the tangential actions in the same directions.

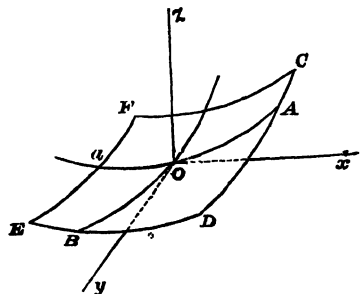

$Oz$  being the normal at  $O$ , draw four planes parallel to, and very near to, the normal planes  $AOz$ ,  $BOz$ , cutting the surface in  $CD$ ,  $DE$ ,  $EF$ ,  $FC$ .

Then, ultimately, the tangential actions,  $T \cdot CD$  and  $T \cdot EF$  on  $CD$  and  $EF$ , are equal and opposite, as are also those on  $ED$  and  $CF$ .

Hence, by taking moments about  $Oz$ , it appears that  $T = T'$ , as in Art. (138).

If  $\theta$  be the inclination to the plane  $xy$  of the tangent at  $A$  to the curve  $CD$ ,

$$\tan \theta = \frac{\partial^2 z}{\partial x \partial y} \cdot OA^*$$

and similarly at the point  $a$ ,

$$\tan \theta' = \frac{\partial^2 z}{\partial x \partial y} (-Oa).$$

Hence the sum of the actions  $T \cdot CD$  and  $T \cdot EF$  in the direction  $Oz$

$$= T \cdot CD \frac{\partial^2 z}{\partial x \partial y} OA - T \cdot EF \frac{\partial^2 z}{\partial x \partial y} (-Oa) = T \cdot CD \cdot DE \cdot \frac{\partial^2 z}{\partial x \partial y},$$

and a similar term arises from the action  $T'$ .

Resolving along  $Oz$ , we now obtain

$$p \cdot CD \cdot DE = 2tCD \frac{OA}{r} + 2t' DE \frac{OB}{r'} + 2T \cdot CD \cdot DE \frac{\partial^2 z}{\partial x \partial y},$$

and

$$\therefore p = \frac{t}{r} + \frac{t'}{r'} + 2T \frac{\partial^2 z}{\partial x \partial y} \dagger.$$

147. The same result may be deduced from the formulæ of Arts. (139) and (145), and though this method is a much longer one, it emphasizes the importance of distinguishing between directions of principal tension and directions of principal curvature.

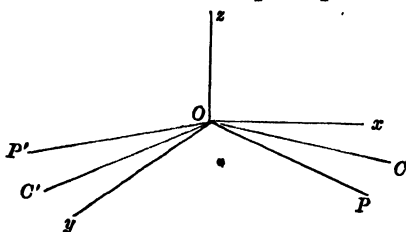

If  $t_x, t_y$  are the tensions in any two directions  $Ox, Oy$  at right angles to each other, and  $T$  the tangential action in either of these

\* For we may write

$$\tan \theta = f(OA) = f(0) + OA \cdot f'(0) + \dots$$

where  $f(0)$  = value of  $\tan \theta$  at  $O$ , i.e. value of  $\frac{\partial^2 z}{\partial x \partial y}$  at  $O$ , and  $f'(0)$  = value of  $\frac{\partial}{\partial x} \left( \frac{\partial z}{\partial y} \right)$  or  $\frac{\partial^2 z}{\partial x \partial y}$  at  $O$ .

† The general question of the equilibrium of flexible surfaces is discussed in a paper by W. H. Besant, in the *Quarterly Journal of Mathematics*, Vol. iv. 1860.

directions, and  $t, t'$  the principal tensions in directions  $OP, OP'$  and the angle  $POx = \theta$ ; then by Art. (139),

$$t_x = t \cos^2 \theta + t' \sin^2 \theta,$$

$$t_y = t \sin^2 \theta + t' \cos^2 \theta,$$

and

$$T = (t - t') \sin \theta \cos \theta.$$

Again, if  $OC, OC'$  are the directions of principal curvature and the angle  $COx = \phi$ , and  $\rho, \rho'$  are the principal radii of curvature and  $r_x, r_y, r, r'$  those of the normal sections through  $Ox, Oy, OP, OP'$ ; then

$$\frac{1}{r_x} = \frac{\cos^2 \phi}{\rho} + \frac{\sin^2 \phi}{\rho'}, \quad \frac{1}{r_y} = \frac{\sin^2 \phi}{\rho} + \frac{\cos^2 \phi}{\rho'},$$

$$\frac{1}{r} = \frac{\cos^2 (\theta - \phi)}{\rho} + \frac{\sin^2 (\theta - \phi)}{\rho'}, \quad \frac{1}{r'} = \frac{\sin^2 (\theta - \phi)}{\rho} + \frac{\cos^2 (\theta - \phi)}{\rho'};$$

$$\begin{aligned} \therefore \frac{t_x}{r_x} + \frac{t_y}{r_y} &= (t \cos^2 \theta + t' \sin^2 \theta) \left( \frac{\cos^2 \phi}{\rho} + \frac{\sin^2 \phi}{\rho'} \right) \\ &\quad + (t \sin^2 \theta + t' \cos^2 \theta) \left( \frac{\sin^2 \phi}{\rho} + \frac{\cos^2 \phi}{\rho'} \right) \\ &= t \left\{ \frac{\cos^2 (\theta - \phi)}{\rho} - \frac{\sin 2\theta \sin 2\phi}{2\rho} + \frac{\sin^2 (\theta - \phi)}{\rho'} + \frac{\sin 2\theta \sin 2\phi}{2\rho'} \right\} \\ &\quad + t' \left\{ \frac{\sin^2 (\theta - \phi)}{\rho} + \frac{\sin 2\theta \sin 2\phi}{2\rho} + \frac{\cos^2 (\theta - \phi)}{\rho'} - \frac{\sin 2\theta \sin 2\phi}{2\rho'} \right\} \\ &= \frac{t}{r} + \frac{t'}{r'} - (t - t') \sin \theta \cos \theta \sin 2\phi \cdot \left( \frac{1}{\rho} - \frac{1}{\rho'} \right) \\ &= \frac{t}{r} + \frac{t'}{r'} - T \sin 2\phi \cdot \left( \frac{1}{\rho} - \frac{1}{\rho'} \right); \\ \therefore \frac{t_x}{r_x} + \frac{t_y}{r_y} + T \sin 2\phi \left( \frac{1}{\rho} - \frac{1}{\rho'} \right) &= \frac{t}{r} + \frac{t'}{r'} = p. \end{aligned}$$

But the equation to the surface in the neighbourhood of  $O$  may be written  $2z = \frac{x^2}{\rho} + \frac{y^2}{\rho}$  referred to  $OC, OC'$ , and the normal  $Oz$  as axes; or  $2z = ax^2 + 2hxy + by^2$  referred to  $Ox, Oy, Oz$ , and since  $\phi$  is the angle between the two systems of axes,

$$\sin 2\phi = \frac{2h}{\sqrt{(a-b)^2 + 4h^2}}$$

and

$$\begin{aligned} (a-b)^2 + 4h^2 &= (a+b)^2 - 4(ab-h^2) \\ &= \left( \frac{1}{\rho} + \frac{1}{\rho'} \right)^2 - \frac{4}{\rho\rho'} \\ &= \left( \frac{1}{\rho} - \frac{1}{\rho'} \right)^2; \end{aligned}$$

and  $h$  is clearly the value of  $\frac{\partial^2 z}{\partial x \partial y}$  at  $O$ ,

$$\therefore \sin 2\phi \cdot \left( \frac{1}{\rho} - \frac{1}{\rho'} \right) = 2 \frac{\partial^2 z}{\partial x \partial y};$$

$$\therefore \frac{t_x}{r_x} + \frac{t_y}{r_y} + 2T \frac{\partial^2 z}{\partial x \partial y} = p.$$

**148.** We observe that if the chosen directions  $Ox$ ,  $Oy$  coincide with the directions of principal curvature, then  $\phi = 0$  and the formula reduces to

$$\frac{t_x}{r_x} + \frac{t_y}{r_y} = p,$$

so that this formula holds good when the chosen directions are either directions of principal tension or directions of principal curvature.

**149.** If we imagine a surface of such a nature that the tension at any point is always perpendicular to a line of division through that point, it can be shewn that the tension at any point is the same in every direction.

Considering a small triangular portion of the surface the equilibrium in the tangent plane is entirely determined by the tensions of the sides of the triangle, for the tangential impressed forces, if there be any, will ultimately vanish in comparison with the tensions; and since these tensions are perpendicular to the sides, they must be in the ratio of their lengths, and therefore the measures of tension in all directions are the same.

Further, the tension will be the same over the surface, for, if a small rectangular element be considered, the tensions on the opposite sides must be equal.

The conception of such a surface is of the same nature as the conception of a perfectly rigid body or of a perfect fluid; nevertheless we obtain approximate specimens in the case of liquid films, such as soap-bubbles, or the films which may be seen in a clear glass bottle containing liquid which has been shaken about.

The consideration of the equilibrium of liquid films we defer to a subsequent chapter.

**150.** *A vessel, formed of flexible and inextensible material, is in the form of a surface of revolution, and is held with its axis*

vertical, and filled with homogeneous liquid: it is required to determine the principal tensions at any point.

Let  $O$  be the lowest point of the vessel, and take  $O$  for the origin.

Measure  $x$  vertically upwards, and let  $PEQ$  be any horizontal section, the upper rim being  $ACB$ , which is supposed to be fixed.

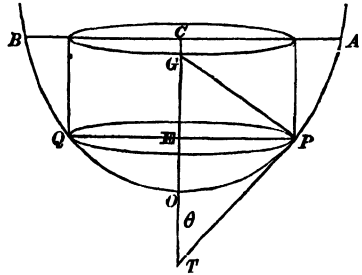

At all points of the horizontal section  $PQ$ , the tensions are evidently the same.

Let  $t$  be the meridional tension, i.e. the tension at  $P$ , in direction of the tangent at  $P$  to the curve  $AP$ , and  $t'$  the horizontal tension at  $P$ ; these are the principal tensions.

The vertical resultant of the tension  $t$  along the section  $PQ$  counterbalances the resultant vertical pressure on the surface  $POQ$ ; hence, if

$$OE = x, \quad EP = y, \quad \text{and angle } PTO = \theta,$$

$$2\pi y t \cos \theta = \int_0^x g\rho\pi y'^2 dx' + g\rho\pi y^2 (c - x), \quad \text{if } OC = c.$$

This equation determines  $t$ , and  $t'$  is given by the equation

$$\frac{t}{r} + \frac{t'}{r'} = p, \quad \text{Art. (145)*,}$$

where  $p = g\rho(c - x)$ .

It will be observed that  $r$  is the radius of curvature of the curve  $AP$  at  $P$ , and that  $r'$ , the radius of curvature of the perpendicular normal section, is the normal  $PG$ .

**151.** A more general proposition is the following:

*A flexible vessel, in the form of a surface of revolution, is subject to fluid pressure, such that it is the same at all points of the same circular section; it is required to determine the principal tensions at any point.*

\* This equation may also be obtained, for this case, by taking a small element bounded by lines of curvature, that is by meridians and horizontal circles; it will be necessary to employ Meunier's theorem, and to observe that the osculating planes of lines of curvature are not generally normal planes.

Let  $PEQ$ ,  $P'E'Q'$  be two consecutive circular sections, and let  $t$  be the meridional tension at  $P$ .

If  $OP = s$ , the resultant tension, parallel to the axis, on the circle  $PQ$ ,

$$= 2\pi y t \frac{dx}{ds};$$

$\therefore$  the resultant tension, parallel to  $Ox$ , on  $P'Q'$ ,

$$= 2\pi \left\{ y t \frac{dx}{ds} + \frac{d}{ds} \left( y t \frac{dx}{ds} \right) \delta s \right\}, \text{ if } PP' = \delta s.$$

The difference of these two counterbalances the resultant pressure, parallel to  $Ox$ , on the strip of surface between the circles  $PQ$ ,  $P'Q'$ , which is equal to

$$p \cdot 2\pi y \delta s \frac{dy}{ds},$$

if  $p$  be the pressure at any point of the circle  $PQ$ ;

$$\therefore \frac{d}{ds} \left( y t \frac{dx}{ds} \right) = p y \frac{dy}{ds},$$

and  $p$  being a given function of  $x$ , and therefore of  $s$ , this equation determines the tension  $t$ , and, as before,  $t'$  is given by the equation

$$\frac{t}{r} + \frac{t'}{r'} = p.$$

**152.** By eliminating  $p$  we obtain a relation between  $t$  and  $t'$ , but it is better to obtain the relation directly.

Taking a small element  $PP'R'R$  bounded by meridian arcs,  $PP'$ ,  $RR'$ , and by circular arcs  $PR$ ,  $P'R'$ , let  $\delta\phi$  be the angle between the meridian planes and  $2\delta\psi$  the angle between the tangent lines, at  $P$  and  $R$ , to the meridians.

Then  $PR = y\delta\phi$ , and  $PP' = \delta s$ .

Resolving parallel to the direction of the meridian bisecting  $PR$  and  $P'R'$ ,

$$\begin{aligned} \frac{d}{dy} (ty\delta\phi) \delta y &= 2t'\delta s \sin \delta\psi, \\ &= t'\delta s \cdot \frac{PR}{PT} = t'\delta s \frac{y\delta\phi}{PT}, \end{aligned}$$

and, since

$$\frac{y}{PT} = \sin \theta = \frac{dy}{ds}, \text{ fig. Art. (150),}$$

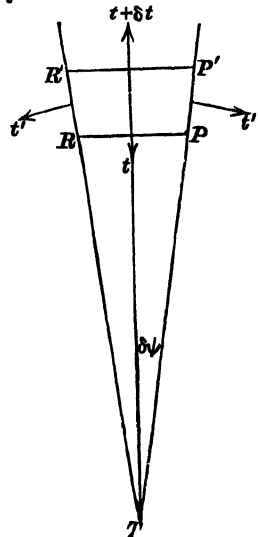
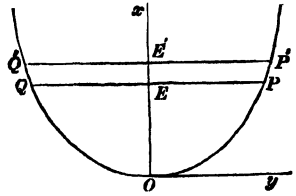

we obtain the equation

$$\frac{d}{dy}(ty) = t'.$$

Observing that  $r' = y \sec \theta$ , we also have

$$\frac{t}{r} + \frac{t' \cos \theta}{y} = p,$$

and therefore  $t$  and  $t'$  are determined by these two equations.

From the first of these equations, we observe that, if at any horizontal section  $t$  is a maximum or a minimum, so that  $dt/dy$  vanishes, then

$$t' = t.$$

But if  $y$  is also a maximum or a minimum this relation does not follow, for we cannot infer that  $dt/dy$  vanishes. Again if  $t' = t$  at every point, it follows that  $dt/dy = 0$ , and therefore that  $t$  is constant.

**153. EXAMPLE.** (1) *A conical perfectly flexible and elastic bag attached, mouth downwards, by the rim to a horizontal plane, and filled with liquid by a small hole at the apex, has, when at rest, the figure of a right circular cone; find the equation to the figure it will assume when detached and the liquid let out, neglecting its weight.*

Let  $t$  be the tension at  $P$  in the direction perpendicular to the generating line  $VP$ ,  $t'$  the tension in the direction  $VP$ , and  $2a$  the vertical angle of the cone.

Then  $p = \frac{t}{r} + \frac{t'}{r}$  gives, if  $VN = x$ ,

$$g\rho x = \frac{t}{PN} = \frac{t}{x \tan a \sec a},$$

or

$$t = g\rho x^2 \tan a \sec a.$$

But  $2\pi PNt \cos a =$  the resultant vertical pressure on  $VPQ$

$$= \frac{2}{3} g\rho \pi x^3 \tan^2 a;$$

$$\therefore t = \frac{1}{3} g\rho x^2 \tan a \sec a.$$

Let  $V'P'Q'$  be the generating curve of the surface of revolution into which the surface forms itself after the liquid has been let out,  $V'N = \xi$ ,  $P'N = \eta$ ,  $P'$  corresponding to the point  $P$ .

If  $P'Q' = \delta s$ , a small arc of the curve,

$$\delta x \sec a = \delta s \left(1 + \frac{t'}{\lambda}\right),$$

and

$$x \tan a = \eta \left(1 + \frac{t}{\lambda}\right),$$

taking the modulus of elasticity different in the two directions.

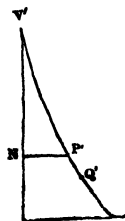
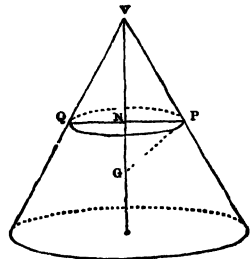

Taking account of the values of  $t$  and  $t'$  obtained above,  $x$  can be eliminated between these two equations, and the relation between  $\xi$  and  $\eta$  will result.

From the first equation, putting  $\frac{g\rho \tan a \sec a}{3\lambda'} = \frac{1}{a^2}$ ,

$$\frac{ds}{dx} \cos a = \frac{1}{1 + \frac{x^2}{a^2}};$$

$$\therefore \frac{s}{a} \cos a = \tan^{-1} \frac{x}{a}, \text{ measuring } s \text{ from } V,$$

or 
$$\frac{x}{a} = \tan \left( \frac{s}{a} \cos a \right).$$

Substituting this expression for  $x$  in the second equation, we obtain

$$a \tan a \tan \left( \frac{s}{a} \cos a \right) = \eta \left\{ 1 + \frac{g\rho a^2 \tan a \sec a}{\lambda} \tan^2 \left( \frac{s}{a} \cos a \right) \right\},$$

as the differential equation to the curve.

$$\text{If } \lambda = \lambda', a \tan a = \eta \left\{ \cot \left( \frac{s}{a} \cos a \right) + 3 \tan \left( \frac{s}{a} \cos a \right) \right\}.$$

(2) *A flexible membrane in the form of a catenoid, that is, of the surface generated by the revolution of a catenary about its directrix, has its ends fastened to two equal circular boards of radius  $a$ , and the excess  $p$  of the air pressure inside over the air pressure outside is given.*

In this case the curvatures are in opposite directions, and if  $PG$  be the normal at  $P$ , each radius of curvature is equal to  $PG$ , and the equations of equilibrium are

$$t' - t = p \cdot PG, \text{ and } t' = \frac{d}{dy} (yt);$$

and since

$$PG = \frac{y^2}{c}, \quad c \frac{dt}{dy} = py,$$

$$\therefore 2c(t - \tau) = p(y^2 - c^2),$$

$\tau$  being the meridian tension at the vertex;

and

$$t' = \tau + \frac{p}{2c}(3y^2 - c^2).$$

The first of these equations may at once be obtained by considering the equilibrium of the portion  $AP$ ,  $A$  denoting the vertex of the catenary, and then the value of  $t'$  follows from the equation,  $t' - t = pr$ .

Neglecting the weights of the boards, and supposing the form of equilibrium to be maintained by the inside air pressure, we obtain

$$2\pi a \left\{ \tau + \frac{p}{2c}(a^2 - c^2) \right\} \frac{c}{a} = p\pi a^2,$$

which gives

$$2\tau = pc,$$

and the tensions then become

$$t = \frac{py^2}{2c}, \text{ and } t' = \frac{3py^2}{2c}.$$

**154.** We have hitherto considered only laminae of uniform thickness, but, in order to include cases in which the lamina is of variable thickness, a more general measure of the tension can be given.

Suppose a bar  $AB$  of any homogeneous material to support a weight  $W$ , and let  $\kappa$  be the area of the section of the bar; then the tension at the section through  $P$  supports  $W$  and the weight of the bar  $PB$ ; and if  $\tau\kappa$  is equal to the sum of these weights,  $\tau$  is the measure of the tension at  $P$  per unit of area.

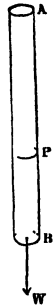

It will be seen that  $\tau$  is one dimension lower than  $t$ .

In fact, if  $e$  be the thickness of a flexible lamina at any point, the tension at which, measured in the usual way per unit of length of section, is  $t$ , we have

$$t\delta s = \tau e\delta s,$$

or

$$t = e\tau.$$

**155.** The investigations of this chapter will not in general be applicable to surfaces which are inflexible, or of imperfect flexibility, but, if in any particular case the action between adjacent portions of a surface be wholly in the tangent plane, the relations obtained between the tension and the normal pressure will hold good.

For instance, if a vertical circular cylinder formed of any inflexible substance be filled with fluid, the action at any point will be wholly tangential and of the nature of tension.

### EXAMPLES

1. Supposing the cylinders of a Bramah's Press made of the same material and the stress to be the same in each, what should be the ratio of the thicknesses of the cylinders?

2. A cylindrical vessel is formed of metal  $\alpha$  inches thick, and a bar of this metal, of which the section is  $A$  square inches, will just bear a weight  $W$  without breaking. If the cylinder be placed with its axis vertical, find how much fluid can be poured into it without bursting it.

3. The tensile strength of cast iron being 16000 lb.-weight per square inch of section, find the thickness of a cast iron water-pipe whose internal diameter is 12 inches, that the stress upon it may be only one-eighth of its ultimate strength when the head of water is 384 feet.

4. A hollow cone, the vertex of which is downwards, is filled with water; find where the horizontal tension is greatest.

Also find where the tension in the direction of a generating line is greatest.

5. The top of a rectangular box is closed by an uniform elastic band, fastened at two opposite sides, and fitting closely to the other sides; the air being gradually removed from the box, find the successive forms assumed by the elastic band; and when it just touches the bottom of the box, find the difference between the external and internal atmospheric pressures.

6. An elastic tube of circular bore is placed within a rigid tube of square bore which it exactly fits in its unstretched state, the tubes being of indefinite length; if there be no air between the tubes and air of any pressure be forced into the elastic tube, shew that this pressure is proportional to the ratio of the part of the elastic tube that is in contact with the rigid tube to the part that is curved.

7. A vessel, formed of a thin substance, in the shape of a cone with its axis vertical and vertex downwards, is just filled with liquid and closed at the top. If it be made to rotate uniformly about its axis, find the principal tensions at any point.

8. A spherical elastic envelope is surrounded by, and full of, air at atmospheric pressure ( $\Pi$ ), when an equal amount is forced into it. Prove that the tension at any point of the envelope then becomes  $\Pi(2r^3 - r'^3)/2r^2$ , where  $r, r'$  denote the initial and final radii.

9. An elastic spherical envelope, whose natural radius is  $a$ , has air forced into it so that its radius becomes  $b$ ; it is then placed under an exhausted receiver, and its radius increases to  $c$ ; find the quantity of air forced in, assuming that the tension is proportional to the increase of surface.

10. An elastic spherical envelope of radius  $a$  is filled with air at the same pressure and temperature  $T$  as the surrounding air. Assuming that the tension varies as the increase of surface, and that if the quantity of air inside be doubled, the radius becomes  $ma$ , and that if the temperature inside be then raised to  $T'$ , the radius becomes  $na$ , prove that

$$2 \frac{T'}{T} = n^3 + \frac{n^2(n^2 - 1)(2 - m^2)}{m^2(n^2 - 1)}.$$

11. A hemispherical bag of radius  $a$ , supported at its rim, is filled with water; shew that the principal tensions at a depth  $x$  are in the ratio

$$x^2 + ax + a^2 : 2x^2 + 2ax - a^2.$$

Find also where the horizontal tension vanishes, and explain the circumstance of its being negative for a portion of the bag.

12. If the hemispherical bag be closed at the top by a rigid plane to which its rim is tied, and then inverted, shew that the principal tensions at a depth  $x$  are in the ratio

$$3a - 2x : 9a - 4x.$$

13. A spherical envelope of radius  $a$  is just filled with liquid of density  $\rho$ , which rotates about a diameter with uniform angular velocity  $\omega$ ; neglecting gravity, prove that the principal tensions at an angular distance  $\phi$  from the axis of rotation are

$$\frac{1}{2}\rho\omega^2 a^3 \sin^2 \phi \text{ and } \frac{3}{2}\rho\omega^2 a^3 \sin^2 \phi.$$

14. A cylindrical shell of finite thickness is formed of a material such that a bar, one square inch in section, can sustain a tension  $\tau$  without giving way. If this shell be subjected to an internal fluid pressure  $\omega$ , which is only just not sufficient to burst the cylinder, prove that  $\omega = \tau \log \frac{a}{b}$ , where  $a$  and  $b$  are the external and internal radii of the shell.

15. A cone contains heavy liquid; if the tension of the cone in the direction of the generating lines is the same at all points, prove that the density of the liquid varies inversely as the square of its height above the vertex.

16. A convex inextensible pliable envelope in the form of a surface of revolution with its axis vertical is exposed to water pressure from within. Prove that at the widest part the tension along the meridians is a maximum or a minimum according as it is less or greater than the tension across the meridians.

17. A flexible bag, in the form of a right circular cone, just filled with liquid, has the rim of its base fastened to a rigid plane, and the liquid is acted upon by repulsive forces from the centre of the base, varying as the distance; find the principal tensions at any point.

If an aperture be made in the rigid plane, fitted with a piston, and a blow be struck on the piston, find the principal impulsive tension at any point.

18. If, in Art. (151), the vessel be a paraboloid, and if the principal tensions be equal at any point of the horizontal section through the focus, shew that the length of the axis is  $\frac{2}{3}$  ths of the latus rectum.

19. A quantity of liquid within a thin spherical shell rotates about the vertical diameter with uniform angular velocity: find the principal tensions at any point, and examine the effects of an increase in the velocity of rotation.

20. A flexible surface, such that the tension at any point is the same in every direction, and whose form is given by the equation  $z = \phi(x, y)$ , is exposed to the action of fluid; find the ratio of the pressure to the tension at any point.

Shew that this ratio is 1 : 3 at the points of the surface  $4x^2 = 3z^2(x^2 + y^2)$ , where  $x = y = z$ .

21. A right circular cylinder is made of elastic material attached to rigid fixed plane ends. It is distended by fluid pressure. Supposing that the tensions in the meridian and circular sections are regulated by Hooke's law, obtain equations sufficient to determine completely the shape it will assume. If the pressure  $p$  be constant, prove that the meridian curve is

$$\frac{1}{2} \quad x + A = \int \left( \frac{py^2}{2} + B \right) \left\{ \left( \frac{\lambda y^2}{2a} - \lambda y + C \right)^2 - \left( \frac{py^2}{2} + B \right)^2 \right\}^{-\frac{1}{2}} dy,$$

where  $a$  is the original radius,  $\lambda$  one of the moduli of elasticity, and  $A, B, C$  constants of integration.

22. If an elastic membrane when unstretched forms the curved surface of a cylinder of radius  $a$ , shew that if its ends be fixed and air be forced into it and its ends closed, the bounding curve of any section through the axis will be given by

$$(y^2 + f) \left( \frac{ap}{\lambda} \sec \phi - 1 \right) = 2a(c - y),$$

where  $\phi$  is the angle made by the tangent with the axis,  $y$  the perpendicular on the axis,  $p$  the difference of the external and internal pressures, and  $\lambda$  the coefficient of elasticity. Explain how the constants  $c, f$  and a third obtained on integrating the equation must be found.

23. A vessel is constructed of thin flexible and inextensible material, in the shape of the surface formed by the revolution of a catenary, of which  $c$  is the parameter, about its axis. If  $t, t'$  are the principal tensions at the distance  $x$  from the axis, prove that

$$2t - t' : 2t = x/c : \sinh 2x/c,$$

the difference of the pressures inside and outside being supposed constant.

24. If a flexible vessel, generated by the revolution of a cycloid about its base, is just full of liquid which rotates uniformly about the axis under the action of no external forces, prove that the ratio of the tensions along and perpendicular to the meridian curves is as 2 : 7 ; the pressure being assumed to vanish at the axis.

25. The shape of a perfectly flexible vessel is that produced by rotating a cycloid about its axis, which is vertical. Shew that if the vessel is nearly full of water the horizontal tension at a point where the tangent plane is inclined at  $45^\circ$  to the horizon is  $\sqrt{2} \left( \frac{23}{96} - \frac{3\pi^2}{128} \right)$  times the tension at the lowest point. Why may not the vessel be *quite* full?

26. A receptacle for liquid is formed of a weightless disc to which is attached a flexible piece of cloth in the shape of a zone of a sphere radius  $a$ , of which one plane section just fits the disc, and the other passes through the centre of the sphere. This is supported by the rim of the larger section and filled with a heterogeneous liquid whose density varies as  $z(a^2 - z^2)^{-\frac{1}{2}}$ , where  $z$  is the depth : find the ratio of the principal tensions.

27. An inextensible flexible envelope in the form of a paraboloid of revolution (latus rectum  $4a$ ) hangs from a fixed horizontal circle of radius  $c$ ; and contains fluid of density  $\sigma$  which is rotating round the vertical axis of the paraboloidal envelope with angular velocity  $(g/2b)^{\frac{1}{2}}$ . Prove that at any point of the envelope, at distance  $r$  from the axis, the horizontal tension is

$$\frac{1}{4} g \sigma \left\{ \frac{1}{a} - \frac{1}{b} \right\} \frac{c^2 (2a^2 + r^2) - r^2 (3a^2 + r^2)}{(4a^2 + r^2)^{\frac{3}{2}}}.$$

28. A flexible membrane is in the form of a surface of revolution, the meridian curve being such that the normal at any point is  $n$  times the radius of curvature. The membrane is just filled with liquid, and the whole revolves about the axis as if solid, with uniform angular velocity; shew that, if the liquid is under the action of no external forces and the pressure is zero along the axis, the ratio of the principal tensions at any point is  $4 - n : 1$ .

## CHAPTER IX

### RIGID OR ELASTIC LAMINA SUBJECTED TO FLUID PRESSURE

**156.** We shall now consider the case of a cylindrical lamina, subjected to fluid pressure, such that it is the same along any generating line.

If  $APQ$  is a cross-section perpendicular to the generating lines, the stress between the two portions separated by the generating line through  $P$ , perpendicular to the plane of the paper, will consist of a tangential force, a shearing force, and a couple.

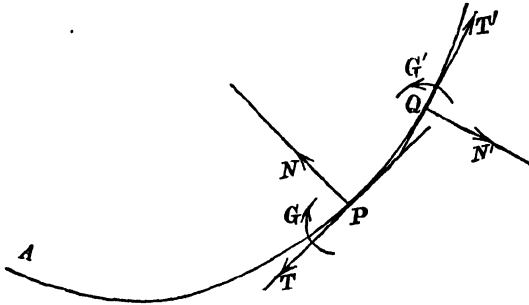

Taking unit length of the generating line, we shall denote these quantities by  $T$ ,  $N$ , and  $G$ , observing that  $T$ ,  $N$ , and  $G$  represent the stresses exerted at  $P$  upon the element  $PQ$ , and that  $T + \delta T$ ,  $N + \delta N$ ,  $G + \delta G$ , in the contrary directions, are the actions at  $Q$  upon  $PQ$ .

Let  $p\delta s$  be the fluid pressure upon  $PQ$  on the concave side, and let  $\phi$  be the deflection of the tangent at  $P$  from the tangent at  $A$ . Then by resolving parallel to the tangent and normal at  $P$ , and by taking moments about  $P$ , we obtain the equations

$$\delta T + (N + \delta N) \delta\phi + p\delta s \cdot \frac{\delta\phi}{2} = 0,$$

$$\delta N - (T + \delta T) \delta\phi + p\delta s = 0,$$

$$\delta G - (N + \delta N) \delta s + (T + \delta T) \frac{\delta s}{2} \cdot \delta\phi - p\delta s \cdot \frac{\delta s}{2} = 0;$$

or, ultimately,

$$\begin{aligned} \frac{dT}{d\phi} + N &= 0, \\ \frac{dN}{d\phi} - T + p \frac{ds}{d\phi} &= 0, \\ \frac{dG}{d\phi} - N \frac{ds}{d\phi} &= 0. \end{aligned}$$

If the form of the lamina is given, that is, if the intrinsic equation of the curve  $AP$  is given, and if  $p$  is a known function of  $\phi$ , these equations determine the stress along any generating line.

**157. Plane lamina.** If the lamina be elastic and naturally plane, we have the additional condition that  $G$  is proportional to the curvature, or that  $G = E/r$ , where  $r$  is the radius of curvature at  $P$ .

In this case the third equation becomes

$$Nr = -\frac{E}{r^2} \frac{dr}{d\phi},$$

and therefore, from the first equation,

$$\frac{dT}{d\phi} = \frac{E}{r^3} \frac{dr}{d\phi},$$

so that

$$T = C - \frac{E}{2r^2}.$$

Substituting these values in the second equation, we obtain the equation

$$\frac{E}{r^3} \frac{d^2r}{d\phi^2} - \frac{3E}{r^4} \left(\frac{dr}{d\phi}\right)^2 + C - \frac{E}{2r^2} = pr.$$

This equation determines the form assumed by the lamina for a given law of pressure, or, if the form be assigned, it determines the law of pressure.

In the case in which  $p$  is constant, or a given function of  $r$ , a first integral of the equation can be obtained by putting  $\left(\frac{dr}{d\phi}\right)^2 = z$ , and we thus find  $\frac{dr}{d\phi}$  in terms of  $r$ .

**158.** If the lamina is naturally of a given cylindrical form, and is bent from its natural form, the couple  $G$ , the flexural

couple, is proportional to the change of curvature, so that if  $r_0$  is the original radius of curvature at  $P$ ,

$$G = E \left( \frac{1}{r} - \frac{1}{r_0} \right).$$

The truth of this equation depends upon the assumption that the length of the mean fibre, across the generating lines, remains unchanged. We also assume that no effect is produced upon the equation by the existence of external fluid pressure.

**159. Elliptic cylinder.** To illustrate the use of these equations, consider the case of an elliptic cylinder, formed of some thin rigid substance, closed at its ends and filled with air, the pressure of which exceeds by  $p$  the pressure of the external air.

Eliminating  $N$ , we obtain

$$\frac{d^2 T}{d\phi^2} + T = pr.$$

Measuring  $s$  and  $\phi$  from one end of the conjugate axis,

$$r = \frac{CD^2}{ab} = \frac{a^2 b^2}{(a^2 \sin^2 \phi + b^2 \cos^2 \phi)^{\frac{3}{2}}},$$

and, by the method of the variation of parameters, it will be found that

$$T = p \cdot (a^2 \sin^2 \phi + b^2 \cos^2 \phi)^{\frac{3}{2}} + A \cos \phi + B \sin \phi,$$

and therefore

$$N = A \sin \phi - B \cos \phi - p \cdot \frac{(a^2 - b^2) \sin \phi \cos \phi}{(a^2 \sin^2 \phi + b^2 \cos^2 \phi)^{\frac{3}{2}}}.$$

Employing the consideration of symmetry, and also the law of the equality of action and reaction, it follows that  $N$  vanishes at the apses, i.e. when  $\phi = 0$ , and when  $\phi = \frac{\pi}{2}$ .

Hence it appears that  $A = 0$ , and  $B = 0$ , and therefore

$$T = \frac{pab}{CD} \quad \text{and} \quad N = -p \frac{a^2 - b^2}{ab} CD \sin \phi \cdot \cos \phi.$$

Also 
$$\frac{dG}{d\phi} = Nr = -p \frac{(a^2 - b^2) a^2 b^2 \sin \phi \cos \phi}{(a^2 \sin^2 \phi + b^2 \cos^2 \phi)^2};$$

$$\begin{aligned} \therefore G &= \frac{1}{2} p \left( \frac{a^2 b^2}{a^2 \sin^2 \phi + b^2 \cos^2 \phi} + \text{const.} \right) \\ &= \frac{1}{2} p (CD^2 + \text{const.}), \end{aligned}$$

so that

$$G' - G = \frac{1}{2} p (CD'^2 - CD^2).$$

**160. The Lintearia.**

We have shewn, in Art. (134), that the Lintearia and the Elastica are identically the same curves.

If two opposite sides of a thin elastic plate are drawn together, and connected by a tightened sheet, the curve formed is the Lintearia of Art. (133).

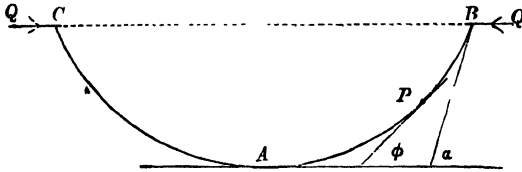

In this case  $p = 0$ , and, as an exercise, it may be useful to observe that the integration of the equation of Art. (157) will lead to the intrinsic equation of the Lintearia.

If  $Q$  is the tension of the connecting sheet, and if  $T$  and  $N$  are the tension and shearing force at  $P$ , we obtain, by considering the equilibrium of the portion  $PB$  of the lamina, the equations

$$T = -Q \cos \phi, \quad N = -Q \sin \phi.$$

**161.** We now propose to determine the law of pressure which will deform a thin elastic lamina, resting on two parallel fixed bars, in the same horizontal plane, into a Lintearia.

The quantities  $T$  and  $G$  will both vanish along the lines in contact with the bars, and therefore the radius of curvature at these lines will be infinite.

Hence in the equation,

$$T = C - \frac{E}{2r^2},$$

we find that  $C = 0$ , and therefore

$$T = -\frac{E}{2r^2}.$$

The intrinsic equation of the Lintearia is

$$r\sqrt{2} = c(\cos \phi - \cos \alpha)^{-\frac{1}{2}},$$

and  $p$  is given by the equation

$$p'' = \frac{E}{r^3} \frac{d^2 r}{d\phi^2} - \frac{3E}{r^4} \left( \frac{dr}{d\phi} \right)^2 - \frac{E}{2r^2}.$$

Making the substitutions it will be found that

$$pr = \frac{E \cos \alpha}{c^2}.$$

Now, in the *Lintearia*, Art. (133),

$$r = \frac{c^2}{PL},$$

so that

$$p = PL \cdot \frac{E \cos \alpha}{c^4},$$

and therefore the requisite pressure can be obtained by pouring in liquid of density  $\rho$ , such that

$$E \cos \alpha = g\rho c^4.$$

Hence it appears that the *Lintearia* form can be maintained by pouring in liquid, of the density given by the preceding equation, to the level of the bars.

Further,

$$N = -\frac{E dr}{r^2 d\phi} = -\frac{E}{c^2} \sin \phi,$$

$$\therefore N = -g\rho c^2 \sin \phi \sec \alpha,$$

$N$  being the shearing force, at  $P$ , of the left-hand portion on the right-hand portion, inwards, so that  $-N$  is the action on the left-hand portion.

Hence at  $B$  and  $C$

$$-N = g\rho c^2 \tan \alpha.$$

This last result can be tested by the fact that the reactions of the bars support the weight of the liquid.

Thus we have

$$\begin{aligned} -2N \cos \alpha &= 2 \int g\rho PL dx \\ &= 2 \int_0^a g\rho \cdot PL \cdot \frac{dx}{ds} \frac{ds}{d\phi} d\phi = 2 \int_0^a g\rho c^2 \cos \phi d\phi \\ &= 2g\rho c^2 \sin \alpha. \end{aligned}$$

**162.** If we have an elastica formed by bending a given plate, and fixing the ending generating lines in the same horizontal plane,  $G=0$ , at  $B$  and  $C$ , and the stress at each end contains tangential and normal components. If we now pour in liquid of the density suitable to the particular elastica, the shape will be unaltered, but the value of  $T$  at  $B$  and  $C$  will be increased, while the value of  $N$  at  $B$  and  $C$  will remain unchanged.

EXAMPLES

1. A vessel of thin rigid material, in the form of half a circular cylinder, is filled with water and supported by vertical forces at its bounding generating lines, which are horizontal; prove that the stresses at any point distant  $\phi$  from the lowest point are such that

$$2T = g\rho a^2 (\phi \sin \phi + \cos \phi), \quad 2N = -g\rho a^2 \phi \cos \phi,$$

$$2G = g\rho a^2 \left( \frac{\pi}{2} - \phi \sin \phi - \cos \phi \right).$$

2. A lamina in the form of a rigid parabolic cylinder bounded by planes perpendicular to the generating lines, forms a vessel which, being closed in by a band of thin cloth joining the generating lines through the ends of the latera recta, is filled with air, the pressure of which exceeds by  $p$  the pressure of the external air. If the breadth of the band of cloth be to the latus rectum,  $(4a)$ , in the ratio  $\pi\sqrt{2} : 4$ , prove that, measuring  $\phi$  from the tangent at the vertex,  $T = pa(\sec \phi - \sqrt{2} \cos \phi)$ , calculate the values of  $N$  and  $G$ , and prove that at the vertex

$$2G = pa^2 (3 + 2\sqrt{2}).$$

3. A rigid cylindrical vessel, the cross-section of which is formed of two cycloidal arcs with the ends fitting together, has an excess of air pressure inside; investigate the stresses along any generating line.

4. A rigid thin lamina in the form of a cylinder, the cross-section of which is the catenary,  $s = c \tan \phi$ , is subjected to an excess  $p$  of air pressure on the concave side, and supported by two equal forces parallel to the axis of the catenary, at the angular distance  $\alpha$  from the vertex; prove that, in this case,

$$\frac{T}{pc} = \cos \phi \sec \alpha - 1 + \sin \phi \log \tan \left( \frac{\pi}{4} + \frac{\phi}{2} \right),$$

$$\frac{N}{pc} = \sin \phi \sec \alpha - \tan \phi - \cos \phi \log \tan \left( \frac{\pi}{4} + \frac{\phi}{2} \right),$$

$$\frac{G}{pc^2} = \sec \phi \sec \alpha - \frac{1}{2} \sec^2 \phi - \frac{1}{2} \left\{ \log \tan \left( \frac{\pi}{4} + \frac{\phi}{2} \right) \right\}^2 + K,$$

where

$$K = \frac{1}{2} \left\{ \log \tan \left( \frac{\pi}{4} + \frac{\alpha}{2} \right) \right\}^2 - \frac{1}{2} \sec^2 \alpha.$$

Prove also that each of the supporting forces

$$= pc \log \tan \left( \frac{\pi}{4} + \frac{\alpha}{2} \right).$$

5. A plane elastic lamina rests on two parallel horizontal bars, and is bent downwards between the bars by a constant air pressure above; prove that the radius of curvature and the deflection are connected by the equation

$$\left( \frac{dr}{d\phi} \right)^2 = Cr^4 - \frac{r^2}{4} - \frac{2p}{E} r^6.$$

6. Find the law of fluid pressure which will bend the same lamina into the form of a catenary.

7. If the same lamina is bent into the form of a parabolic cylinder, resting on the parallel bars, prove that the fluid pressure at the angular deflection  $\phi$  from the vertex varies as

$$\cos^7 \phi (7 \cos^2 \phi - 6).$$

## CHAPTER X

### CAPILLARITY

**163.** It is a well-known fact that if a glass tube of small bore be dipped in water, the water inside the tube rises to a higher level than that of the water outside.

It is equally well known that if the tube be dipped in mercury, the mercury inside is depressed to a lower level than that of the mercury outside.

If a glass tumbler contain water it will be seen that at the line of contact the surface is curved upwards and appears to cling to the glass at a definite angle.

If the tumbler be carefully filled, the level of the water will rise above the plane of the top of the tumbler, the water bulging over the round edge of the top.

If water be spilt on a table, it has a definite boundary, and the curved edges cling to the table.

These facts, and many others, are explained by the existence of forces between the molecules of the fluids, and of the solids and fluids, in contact; the field of action of the force exerted by any particular molecule being infinitely small\*. And since these molecular forces are only exerted at very small distances, it follows that as far as molecular forces are concerned, every element of a homogeneous body, not near its bounding surface, is under the same conditions; but that at the surface itself the sphere of action of a particular molecule is incomplete, and the molecule also falls within the field of action of molecules of whatever matter is on the other side of the bounding surface.

Also if we assume that the linear dimensions of the field of action are infinitely small as compared with the radii of curvature of the surface, then all parts of the surface of separation of two homogeneous substances are

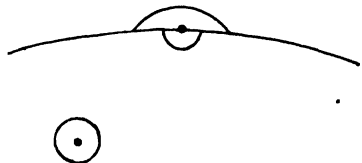

\* The field through which capillary forces are exerted is extremely small. In Quinke's experiments the same phenomena were observed with water in a glass tube silvered with a coating .0000542 mm. thick, as in a silver tube of the same diameter. *Pogg. Ann.* cxxxix. (1870), p. 1.

under similar conditions as far as molecular forces are concerned, and the surface potential energy due to molecular forces must be in a constant ratio to the area of the surface, the constant depending on the nature of the substances in contact.

**164.** *Application of the principle of energy to the case of a homogeneous liquid at rest in a vessel under the action of gravity\*.*

In equilibrium the value of the potential energy must be stationary, and it is composed of four parts: the gravitational energy  $g\rho \iiint z dx dy dz$ , where  $z$  is the height of an element  $dx dy dz$ ; and the energy of the surfaces separating ( $\alpha$ ) liquid and air, ( $\beta$ ) liquid and vessel, ( $\gamma$ ) air and vessel.

Hence we require that

$$g\rho \iiint z dx dy dz + AS_1 + BS_2 + CS_3$$

should be stationary, where  $S_1, S_2, S_3$  denote the surfaces ( $\alpha$ ), ( $\beta$ ), ( $\gamma$ ) and  $A, B, C$  their energies per unit area respectively; subject to the condition that the volume  $\iiint dx dy dz$  is constant.

For a slight displacement of the surface  $S_1$ , between the liquid and air, if  $\delta n$  denote the element of the normal to the surface  $S_1$  between corresponding elements of  $S_1$  in the old and new positions, the variation of the first term is clearly  $g\rho \iint z \delta n dS_1 \dagger$ .

Suppose, in the first place, that the line of contact of the liquid with the vessel does not vary, then  $S_2$  and  $S_3$  are constant and  $S_1$  changes to  $S_1'$ . Consider an element  $ds_1 ds_2$  of  $S_1$  bounded by lines of curvature; the normals through the boundaries of this element cut the surface  $S_1'$  in an element  $ds_1' ds_2'$ , and if  $\rho_1, \rho_2$  are the principal radii of curvature,

$$ds_1' = \left(1 - \frac{\delta n}{\rho_1}\right) ds_1, \quad ds_2' = \left(1 - \frac{\delta n}{\rho_2}\right) ds_2;$$

\* This discussion of the theory of capillarity is taken from Mathieu, *Théorie de la Capillarité*, 1883.

† It is probable that the density of the liquid infinitely near the surface varies owing to the molecular action, but as the thickness of the layer of variable density is infinitely small compared with  $\delta n$ , we may neglect this variation without affecting the argument.

$$\therefore dS_1' - dS_1 = ds_1' ds_2' - ds_1 ds_2 = -\left(\frac{1}{\rho_1} + \frac{1}{\rho_2}\right) \delta n ds_1 ds_2,$$

or 
$$\delta dS_1 = -\left(\frac{1}{\rho_1} + \frac{1}{\rho_2}\right) \delta n \cdot dS_1.$$

But we require that

$$g\rho \iint z \delta n dS_1 + A \delta \iint dS_1 = 0,$$

or, that 
$$\iint \left\{ g\rho z - A \left( \frac{1}{\rho_1} + \frac{1}{\rho_2} \right) \right\} \delta n dS_1 = 0,$$

subject to the condition of constant volume, viz.

$$\iint \delta n dS_1 = 0; \text{ and this is equivalent to}$$

$$\iint \left\{ g\rho (z - h) - A \left( \frac{1}{\rho_1} + \frac{1}{\rho_2} \right) \right\} \delta n dS_1 = 0,$$

where  $h$  is a constant and  $\delta n$  is arbitrary.

$$\therefore A \left( \frac{1}{\rho_1} + \frac{1}{\rho_2} \right) = g\rho (z - h);$$

$$\therefore A \left( \frac{1}{\rho_1} + \frac{1}{\rho_2} \right) = -p + \text{constant},$$

i.e. 
$$A \left( \frac{1}{\rho_1} + \frac{1}{\rho_2} \right) = \Pi - p \dots\dots\dots(1)^*,$$

where  $\Pi$  is the atmospheric pressure and  $p$  the pressure just within the surface of the liquid, so that the effect is the same as if the surface was in a state of tension, the tension at any point being constant and equal to  $A$  the energy per unit area.

Secondly, suppose that the line of contact of the liquid with the vessel is displaced from  $s$  to  $s'$ . If we draw normals to the surface  $S_1$  at all points of the line  $s$ , they will meet the surface  $S_1'$  in a line  $\sigma$ , and the surface  $S_1'$  may be considered as composed of two parts, the one  $\Sigma$  enclosed by the line  $\sigma$ , and the other  $\Sigma'$  between the lines  $\sigma$  and  $s'$ . As before, we get

$$\Sigma - S_1 = - \iint \left( \frac{1}{\rho_1} + \frac{1}{\rho_2} \right) \delta n dS_1;$$

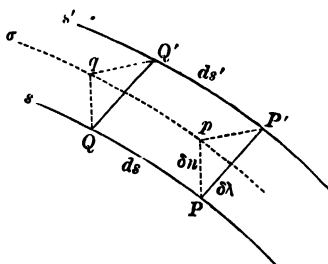
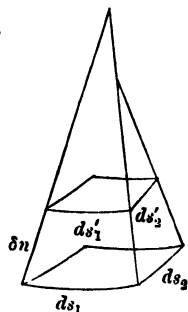

\* That the constant is equal to  $\Pi$  is evident from the consideration that if the surface energy  $A$  were zero, then the pressure in the liquid close to its surface of separation from the air would have to be equal to the atmospheric pressure.

and, if  $\delta\lambda$  denote the distance between the elements  $ds, ds', \Sigma'$  may be considered as the projection of the elements  $\delta\lambda ds$  of the surface of the vessel on the surface  $S_1'$ , so that if  $i$  is the angle between the normals to the surfaces  $S_1$  and  $S_3$ , then

$$\Sigma' = \int \cos i \delta\lambda ds.$$

Also 
$$\delta S_2 = -\delta S_3 = \int \delta\lambda ds.$$

Now since the potential energy is stationary we have

$$\delta \left\{ g\rho \iiint z dx dy dz + AS_1 + BS_2 + CS_3 \right\} = 0$$

subject to the condition that the mass is constant; or

$$g\rho \iint z \delta n dS_1 + A (\Sigma + \Sigma' - S_1) + B\delta S_2 + C\delta S_3 = 0;$$

or 
$$\iint \left\{ g\rho z - A \left( \frac{1}{\rho_1} + \frac{1}{\rho_2} \right) \right\} \delta n dS_1 + \int (A \cos i + B - C) \delta\lambda ds = 0$$

subject to the condition

$$\iint \delta n dS_1 = 0^*,$$

and, since  $\delta\lambda$  is arbitrary, this gives equation (1) as before, and also

$$A \cos i + B - C = 0 \dots\dots\dots(2),$$

or the angle between the surfaces of the liquid and the vessel is constant along the line of their intersection.

**165.** From the foregoing considerations combined with the results of experiment we are led to two laws which may be stated as follows:

(1) *At the bounding surface separating air from a liquid, or between two liquids, there is a surface tension which is the same at every point and in every direction.*

(2) *At the line of junction of the bounding surface of a gas and a liquid with a solid body, or of the bounding surface of two liquids with a solid body, the surface is inclined to the surface of the body at a definite angle, depending upon the nature of the solid and of the liquids.*

\* In the figure,  $PQ$  is an element  $ds$  of the line of contact  $s$  of the liquid with the vessel, and  $P'Q'$ ,  $pq$  are corresponding elements of the lines  $s', \sigma$  respectively:  $P'pqQ'$  is an element of the surface  $\Sigma'$ . The variation in the mass represented by the wedge-shaped elements  $PP'q$  round the line of contact of the liquid and the vessel is of a higher order of small quantities than the rest and may be neglected.

In the case of water in a glass vessel the angle is acute; in the case of mercury it is obtuse.

Assuming these laws we can account for many of the phenomena of capillarity and of liquid films.

**166. Rise of liquid between two plates.**

If  $t$  be the surface tension,  $\alpha$  the constant angle at which the surface meets either plate, called the angle of capillarity,  $h$  the mean rise, and  $d$  the distance between the plates, we have, for the equilibrium of the unit breadth of the liquid,

$$2t \cos \alpha = g\rho h d,$$

so that the rise increases with the diminution of the distance between the plates.

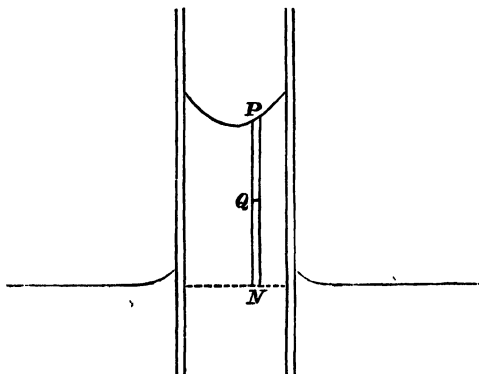

It will be seen that the pressure at any point  $Q$  is less than the pressure at  $N$  by  $g\rho \cdot QN$ ,

$$\text{and } \therefore = \Pi - g\rho QN.$$

The atmospheric pressure at  $P$  being sensibly equal to the pressure at the water level outside, it follows that the weight  $PN$  is supported by the resultant of the surface tensions on its upper boundary.

**167. Rise of a liquid in a circular tube.**

In this case the column of liquid is supported by the tension round the periphery of its upper boundary, and therefore, if  $r$  be the internal radius,

$$2\pi r t \cos \alpha = g\rho \pi r^2 h,$$

or

$$2t \cos \alpha = g\rho r h.$$

The pressure at any point of the suspended column being less than the atmospheric pressure, it follows that if the column were high enough, the pressure would merge into a state of tension, which would still follow the law of fluid pressure of being the same in every direction.

It may be observed that the potential energy, due to the ascent of the column, is independent of the radius.

**168. The Capillary Curve.** The capillary curve is the form assumed by a liquid in contact with a vertical wall.

We shall take the case in which the angle of contact of the liquid with the wall is acute, such for instance as when water is in contact with a vertical plate of glass.

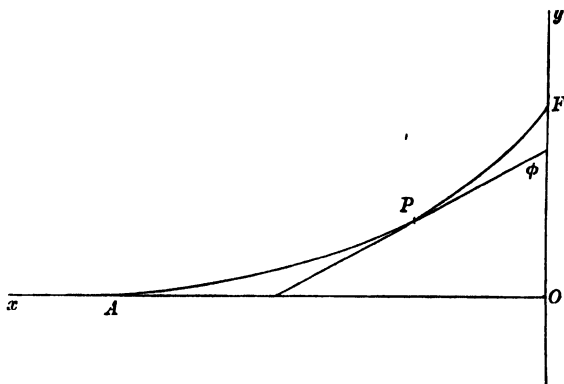

If  $OF$  is the vertical wall, and  $OA$  the natural surface of the liquid,  $r$  the radius of curvature of the section through  $P$  perpendicular to the wall, and  $t$  the surface tension, then equation (1) of Art. (164) gives

$$\frac{t}{r} = \Pi - p = g\rho y.$$

Hence, putting  $4t = g\rho c^2$ ,

$$ry = \frac{c^2}{4},$$

and, inverting the figure of Art. (135), we see that the capillary curve is a particular case of the elastica.

The particularity consists in the fact that  $OA$  is a tangent to the curve, so that  $dy/dx = 0$  when  $y = 0$ , and enables us to obtain the Cartesian equation.

Observing from the figure that  $dy/dx$ , which is the tangent of  $\pi/2 + \phi$ , is negative, and decreasing numerically, it follows that  $d^2y/dx^2$  is positive, and that the equation,  $4ry = c^2$ , becomes

$$\frac{d^2y}{dx^2} / \left\{ 1 + \left( \frac{dy}{dx} \right)^2 \right\}^{\frac{3}{2}} = \frac{4y}{c^2}.$$

Putting  $p \frac{dp}{dy}$  for  $\frac{d^2y}{dx^2}$ , and integrating, we obtain

$$\frac{-1}{(1+p^2)^{\frac{3}{2}}} = \frac{2y^2}{c^2} - 1, \text{ and } \therefore \frac{dx}{dy} = \pm \frac{2y^2 - c^2}{2y \sqrt{c^2 - y^2}}.$$

Observing that the tangent is vertical when  $y \sqrt{2} = c$ , and that the curve should meet the vertical plane at an acute angle, we have  $y \sqrt{2}$  less than  $c$  at all points under consideration, and

$$\therefore \frac{dx}{dy} = \frac{2y^2 - c^2}{2y \sqrt{c^2 - y^2}}.$$

Integrating this equation, and taking the origin in a new position such that  $x = 0$  when  $y = c$ , we obtain

$$x + \sqrt{c^2 - y^2} = \frac{c}{2} \log \frac{c + \sqrt{c^2 - y^2}}{y},$$

or 
$$\frac{y}{c} = \operatorname{sech} \left\{ \frac{2}{c} (x + \sqrt{c^2 - y^2}) \right\}.$$

If  $y = 0$ ,  $x$  is infinite, and, taking the figure of Art. (135), the elastica is identical with the capillary curve when  $BC$  is the tangent at  $B$  and  $C$ , but this is only possible when the length is very great.

If  $\alpha$  is the angle at which the liquid meets the wall, we obtain the height  $OF$  by putting  $-\cot \alpha$  for  $dy/dx$ , so that

$$\frac{c^2}{2y^2 - c^2} = -\operatorname{cosec} \alpha,$$

and 
$$\therefore OF = c \sin \left( \frac{\pi}{4} - \frac{\alpha}{2} \right).$$

In the case of a liquid, such as mercury, for which the angle of contact is obtuse, it will be convenient to measure  $y$  downwards.

**169.** To find the intrinsic equation, measure the arc from  $F$ , and the deflection  $\phi$  from  $FO$ ; then

$$-\frac{c^2}{4r^2} \frac{dr}{d\phi} = \frac{dy}{d\phi} = -r \cos \phi,$$

$$\therefore 1 - \frac{c^2}{8r^2} = \sin \phi, \quad \frac{ds}{d\phi} = \frac{c}{4 \sin\left(\frac{\pi}{4} - \frac{\phi}{2}\right)},$$

and

$$\frac{2s}{c} = \log \frac{\tan\left(\frac{\pi}{8} - \frac{\alpha}{4}\right)}{\tan\left(\frac{\pi}{8} - \frac{\phi}{4}\right)}.$$

If we measure the arc  $\sigma$  and the deflection  $\psi$  from  $A$  and the tangent at  $A$ ,

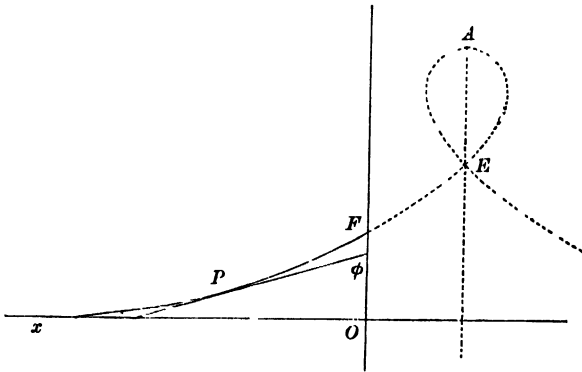

then, when  $\phi = -\frac{\pi}{2}, \quad s = -FA,$

and when  $\phi = \psi - \frac{\pi}{2}, \quad s = -(FA - \sigma),$

and we shall obtain

$$\frac{2\sigma}{c} = \log \tan\left(\frac{\pi}{4} + \frac{\psi}{4}\right),$$

which is the equation obtained in Art. (135).

**170. Parallel Plates.** *Form of the surface of a liquid between two parallel vertical plates, of the same substance, which are partially immersed in the liquid.*

In this case it will be convenient to take the axis  $Oy$  halfway between the plates, and the origin  $O$  in the natural surface of the liquid, and further, to measure the deflection  $\phi$  from the tangent at  $A$ .

As in the previous case,

$$ry = \frac{c^2}{4},$$

and 
$$\frac{d^2y}{dx^2} \cdot \left\{ 1 + \left( \frac{dy}{dx} \right)^2 \right\}^{-\frac{3}{2}} = \frac{4y}{c^2}.$$

Hence we obtain

$$\frac{2y^2}{c^2} = C - \left\{ 1 + \left( \frac{dy}{dx} \right)^2 \right\}^{-\frac{1}{2}} = C - \cos \phi,$$

so that  $C - \cos \phi$  must be positive, and therefore  $C$  must be  $> 1$ .

Again 
$$y \frac{ds}{d\phi} = \frac{c^2}{4},$$

$$\therefore \frac{2\sqrt{2}}{c} \frac{ds}{d\phi} = \frac{1}{\sqrt{C - \cos \phi}}.$$

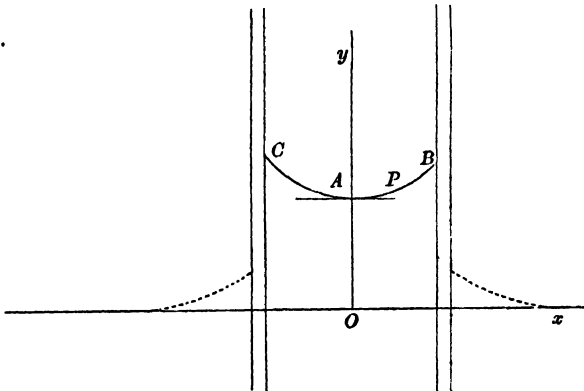

Put  $\cos \phi = z$  and  $\sqrt{2}s/c = u,$

$$\therefore 2du = \frac{-dz}{\sqrt{\{(1-z^2)(C-z)\}}},$$

$$z = v + C/3$$

and substituting  
this becomes

$$du = \frac{-dv}{\sqrt{\{4(v-2C/3)(v-1+C/3)(v+1+C/3)\}}},$$

or 
$$u = \int \frac{dv}{\sqrt{\{4(v-e_1)(v-e_2)(v-e_3)\}}},$$

where  $e_1 = 2C/3, \quad e_2 = 1 - C/3, \quad e_3 = -1 - C/3,$

so that 
$$e_1 > e_2 > e_3.$$

Hence  $v = \wp(u + \epsilon)$ , where  $\epsilon$  is a constant.

Now  $z$  or  $\cos \phi$  lies between 1 and  $\sin \alpha$ , where  $\alpha$  is the angle of capillarity,

$$\therefore 1 - C/3 > v > \sin \alpha - C/3,$$

or  $e_2 > v > e_3$ ;

and hence it follows that as  $\wp(u + \epsilon)$  lies between  $e_2$  and  $e_3$ , the imaginary part of  $\epsilon$  must be the imaginary half-period  $\omega_3$ . Also  $v = e_2$  when  $\phi = 0$  or  $z = 1$ , and if we measure  $s$  from  $A$  then  $u = 0$  when  $\phi = 0$ , and so we must have  $\wp \epsilon = e_2 = \wp \omega_2$ , and therefore  $\epsilon = \omega_2 = \omega_1 + \omega_3$ ; and  $v = \wp(u + \omega_2)$ .

Again 
$$\frac{dx}{ds} = \cos \phi = v + \frac{1}{2}e_1,$$

$$\therefore \frac{\sqrt{2}}{c} \frac{dx}{du} = \wp(u + \omega_2) + \frac{1}{2}e_1,$$

$$\therefore \sqrt{2}x/c + \text{constant} = -\zeta(u + \omega_2) + \frac{1}{2}e_1u$$

and  $x = 0$  when  $u = 0$ , so that

$$\sqrt{2}x/c = \frac{1}{2}e_1u - \zeta(u + \omega_2) + \zeta\omega_2 \dots \dots \dots (1).$$

We have also  $2y^2/c^2 = C - z = e_1 - v,$

that is  $2y^2/c^2 = e_1 - \wp(u + \omega_2) \dots \dots \dots (2).$

To complete the solution, we have that if  $2a$  be the distance between the plates, then the  $u$  corresponding to  $x = a$  is given by

$$\sin \alpha = z = \wp(u + \omega_2) + C/3,$$

and since 
$$\wp(u + \omega_2) = e_2 + \frac{(e_2 - e_1)(e_2 - e_3)}{\wp u - e_2} \dots \dots \dots (3),$$

$$\therefore \sin \alpha = 1 + \frac{2(1 - C)}{\wp u - 1 + C/3},$$

that is 
$$\wp u = \frac{C(5 + \sin \alpha)/3 - (1 + \sin \alpha)}{3(1 - \sin \alpha)}.$$

We may further remark that the relation (3) enables (2) to be written  $2y^2/c^2 = (C - 1) \frac{\wp u - e_3}{\wp u - e_2}$ ; also that the elevations of the points  $A, B$  are given by  $2y^2/c^2 = C - 1$ , and  $C - \sin \alpha$ , respectively.

**171. Circular Tube.** *Differential equation for the form of the surface of a liquid inside a vertical circular tube, which is partly immersed in the liquid.*

Employing the figure of Art. (170) to represent a meridian section of the surface, we have, from Art. (164) (1),

$$\frac{1}{r} + \frac{1}{r'} = \frac{g\rho y}{t} = \frac{4y}{c^2},$$

$g\rho y$  being the excess of the atmospheric pressure over the pressure of the liquid just beneath its surface.

Hence, since  $r' = x \operatorname{cosec} \phi$ , we obtain the equation

$$\frac{\frac{d^2y}{dx^2}}{\left\{1 + \left(\frac{dy}{dx}\right)^2\right\}^{\frac{3}{2}}} + \frac{1}{x} \cdot \frac{\frac{dy}{dx}}{\left\{1 + \left(\frac{dy}{dx}\right)^2\right\}^{\frac{1}{2}}} = \frac{4y}{c^2},$$

which may be written in the form

$$\frac{d}{dx} \cdot \frac{x \frac{dy}{dx}}{\left\{1 + \left(\frac{dy}{dx}\right)^2\right\}^{\frac{1}{2}}} = \frac{4xy}{c^2}.$$

We have also the boundary condition, that, if  $a$  is the internal radius of the tube, and if  $\alpha$  is the acute angle of contact of the liquid with the surface of the tube,

$$\frac{dy}{dx} = \cot \alpha, \text{ when } x = a.$$

If the angle of contact is obtuse, the liquid will be depressed in the tube, and, if we measure  $y$  downwards,  $g\rho y$  will be the excess of the pressure of the liquid just beneath its surface over the atmospheric pressure.

As the case under consideration includes that of the free surface of the mercury in a barometer tube, it has been the subject of much discussion. A solution of the differential equation for the meridian curve has been obtained by Lohnstein\* in the form of a series which converges so long as the tangent to the curve does not become vertical. The equation was also considered, as an example, in an article on a numerical method of solving differential equations by C. Rünge†; and a geometrical method of approximating to capillary curves suggested by Lord Kelvin in *Nature*‡ has been

\* Dissert. Berlin, 1891.

† *Math. Annalen*, 46 (1895), p. 167.

‡ *Nature*, July and August, 1886.

discussed at length by C. V. Boys\*. A method of approximation has also been given by F. Neumann †.

**172. Drop of Liquid.** If a drop of liquid be placed on a horizontal plane, the equation of equilibrium will be

$$\frac{1}{r} + \frac{1}{r'} = \frac{\varpi}{t},$$

where  $t$  is the surface tension, and  $\varpi$  is the difference between the internal pressure and the atmospheric pressure.

In general the drop will assume the form of a surface of revolution.

Taking this case, let  $\Pi'$  be the pressure inside the liquid at the highest point, and  $\Pi$  the atmospheric pressure; then, measuring  $x$  vertically downwards from the highest point,

$$\begin{aligned} \varpi &= \Pi' + g\rho x - \Pi, \\ \therefore \frac{1}{r} + \frac{1}{r'} &= \frac{\Pi' - \Pi + g\rho x}{t}. \end{aligned}$$

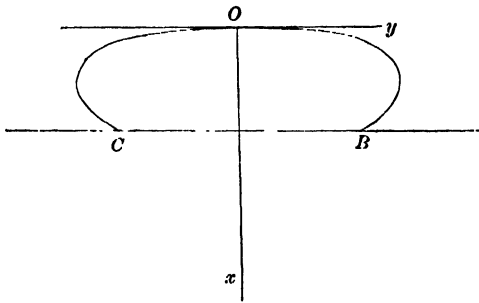

Hence, if  $a$  is the radius of curvature at the highest point,

$$\frac{2}{a} = \frac{\Pi' - \Pi}{t},$$

and  $\therefore \frac{1}{r} + \frac{1}{r'} = \frac{2}{a} + \frac{g\rho x}{t} = \frac{2}{a} + \frac{x}{c^2} \dots\dots\dots(1).$

Taking the case of a drop of mercury upon glass, or of a drop of water upon steel, we observe that  $dy/dx$  is decreasing from the

\* *Phil. Mag.* Series 5, Vol. 36, p. 75, 1893.

† *Vorlesungen über die Theorie der Capillarität.* Leipzig, 1894.

vertex downwards, and we obtain the differential equation of the meridian curve,

$$\frac{-\frac{d^2y}{dx^2}}{\left\{1 + \left(\frac{dy}{dx}\right)^2\right\}^{\frac{3}{2}}} + \frac{1}{y \left\{1 + \left(\frac{dy}{dx}\right)^2\right\}^{\frac{1}{2}}} = \frac{2}{a} + \frac{x}{c^2},$$

$$-\frac{d}{dx} \frac{p}{(1+p^2)^{\frac{3}{2}}} + \frac{1}{y(1+p^2)^{\frac{1}{2}}} = \frac{2}{a} + \frac{x}{c^2}.$$

Hence, if  $\phi$  is the inclination of the tangent at any point of the meridian curve to the axis of  $x$ ,  $p = \tan \phi$ , and

$$\therefore \cos \phi \left( \frac{1}{y} - \frac{d\phi}{dx} \right) = \frac{2}{a} + \frac{x}{c^2}.$$

If the drop be large so that we may consider the top flat, and if we neglect the curvature of horizontal sections, the equation (1) becomes

$$\frac{1}{r} = \frac{x}{c^2},$$

or 
$$-\frac{d}{dx} \frac{p}{\sqrt{1+p^2}} = \frac{x}{c^2},$$

so that 
$$\frac{p}{\sqrt{1+p^2}} = 1 - \frac{x^2}{2c^2},$$
 since  $p = \infty$  when  $x = 0$ ,

or 
$$\frac{dy}{dx} = \frac{2c^2 - x^2}{\sqrt{\{4c^4 - (2c^2 - x^2)^2\}}}.$$

To integrate this equation put  $x = 2c \sin \theta$ ,

so that 
$$dy = c(\operatorname{cosec} \theta - 2 \sin \theta) d\theta;$$

$$\therefore y + b = c \log \tan \frac{\theta}{2} + 2c \cos \theta,$$

or 
$$y + b = c \log \frac{2c - \sqrt{4c^2 - x^2}}{x} + \sqrt{4c^2 - x^2};$$

where  $b$  is a constant.

At the point where the tangent is vertical,  $p = 0$ , and

$$\therefore x = c\sqrt{2}.$$

If  $\alpha$  is the acute angle between the meridian curve and the

horizontal plane, i.e. if  $\pi - \alpha$  is the angle of contact of the mercury with the plane, and if  $h$  is the height of the drop,

$$\phi = -\left(\frac{\pi}{2} - \alpha\right), \text{ when } x = h,$$

and

$$\therefore h = 2c \cos \frac{\alpha}{2}.$$

**173. Drop between parallel plates.** If a drop of mercury be placed between two parallel horizontal plates of glass, so near to each other that the action of gravity may be neglected, the pressure inside the drop will be constant, and, if the surface be a surface of revolution, we shall have the equation

$$\frac{1}{r} + \frac{1}{r'} = \frac{\varpi}{t},$$

where  $\varpi$  is the excess of the inside pressure over the atmospheric pressure.

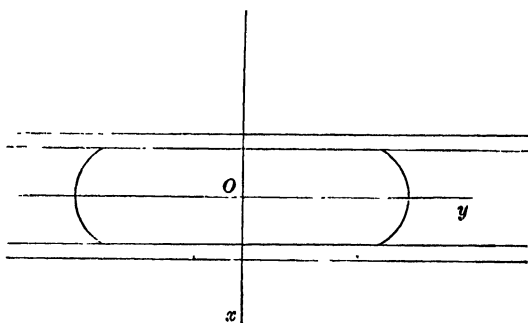

In this case it will be convenient to measure  $x$  downwards from the plane which is midway between the two surfaces of glass, and we then have the equation

$$\frac{-p \frac{dp}{dy}}{(1+p^2)^{\frac{3}{2}}} + \frac{1}{y(1+p^2)^{\frac{1}{2}}} = \frac{\varpi}{t} = \frac{2}{b}, \text{ say.}$$

Integrating, and taking  $l$  as the value of  $y$  when  $x = 0$ ,

$$\frac{by}{(1+p^2)^{\frac{3}{2}}} = y^2 + lb - l^2,$$

so that

$$\frac{dx}{dy} = -\frac{y^2 + lb - l^2}{\sqrt{\{b^2y^2 - (y^2 + lb - l^2)^2\}}}.$$

Put  $y^2 = z$ , then we have

$$dx = - \frac{(z + lb - l^2) dz}{\sqrt{\{4z(z - l^2)(l - b^2 - z)\}}}.$$

Whence if we write  $z = -v + \frac{1}{3}l^2 + \frac{1}{3}(l - b)^2$ , we get

$$dx = \frac{\{-v + \frac{1}{3}(b^2 + lb - l^2)\} dv}{\sqrt{\{4\{v - \frac{1}{3}l^2 - \frac{1}{3}(l - b)^2\}\{v - \frac{1}{3}l^2 + \frac{2}{3}(l - b)^2\}\{v + \frac{2}{3}l^2 - \frac{1}{3}(l - b)^2\}\}}}.$$

Now let 
$$u = \int \sqrt{\{4(v - e_1)(v - e_2)(v - e_3)\}},$$

where  $e_1 = \frac{1}{3}l^2 + \frac{1}{3}(l - b)^2$ ,  $e_2 = \frac{1}{3}l^2 - \frac{2}{3}(l - b)^2$ ,  $e_3 = -\frac{2}{3}l^2 + \frac{1}{3}(l - b)^2$ ,

so that

$$e_1 > e_2 > e_3;$$

then it follows that

$$v = \wp(u + \epsilon),$$

where  $\epsilon$  is a constant.

Now  $dy/dx = 0$  when  $y = l$ , so we may assume that  $y \not> l$  and  $z \not> l^2$ , and for  $dx/dz$  to be real we must therefore also have  $z \not< (l - b)^2$ . Hence we have

$$l^2 \not< -v + \frac{1}{3}l^2 + \frac{1}{3}(l - b)^2 \not< (l - b)^2,$$

or

$$-\frac{2}{3}l^2 + \frac{1}{3}(l - b)^2 \not> v \not> \frac{1}{3}l^2 - \frac{2}{3}(l - b)^2,$$

that is,  $v$  lies between  $e_2$  and  $e_3$ ; so if we take  $u$  to be real it follows that the imaginary part of  $\epsilon$  must be the imaginary half period  $\omega_3$ , and its real part may be taken to be zero by suitable choice of the lower limit for  $u$ ;

$$\therefore v = \wp(u + \omega_3).$$

Hence 
$$dx = \{-\wp(u + \omega_3) + \frac{1}{3}(b^2 + lb - l^2)\} du,$$

and by integration

$$x + \text{const.} = \zeta(u + \omega_3) + \frac{1}{3}u(b^2 + lb - l^2).$$

But

$$x = 0 \text{ when } z = l^2,$$

or when

$$v = -\frac{2}{3}l^2 + \frac{1}{3}(l - b)^2 = e_3 = \wp(\omega_3);$$

so that, for this value of  $x$ ,  $u$  must be zero.

$$\therefore x = \zeta(u + \omega_3) - \zeta(\omega_3) + \frac{1}{3}u(b^2 + lb - l^2)$$

and

$$y^2 = -\wp(u + \omega_3) + \frac{1}{3}(2l^2 - 2lb + b^2)$$

gives the values of the Cartesian co-ordinates in terms of the parameter  $u$ .

If the drop is so large that we can neglect  $1/r'$ , then  $r = \frac{t}{\omega}$ , so that the meridian curve is circular.

In this case, if  $2h$  is the distance between the plates, it is seen from the figure that

$$r = h \sec \alpha,$$

$\alpha$  being the acute angle between the mercury and the surface of each plate outside.

174. If a drop of water between two parallel horizontal plates of glass takes the form of a surface of revolution, the surface will be anticlastic, since the angle of contact of water and glass is acute.

In this case, if  $\Pi$  is the atmospheric pressure, and  $\Pi'$  the pressure of the water inside the drop, and if  $r$  is the radius of curvature of the meridian curve, and  $r'$  the radius of curvature of the perpendicular normal section, that is, the length of the normal intercepted by the axis of the surface, the equation of equilibrium is

$$\frac{1}{r} - \frac{1}{r'} = \frac{\Pi - \Pi'}{t} = \frac{\varpi}{t},$$

for, in resolving along the normal, the resultant of two of the tensions will be outwards, and the resultant of the other two will be inwards in direction.

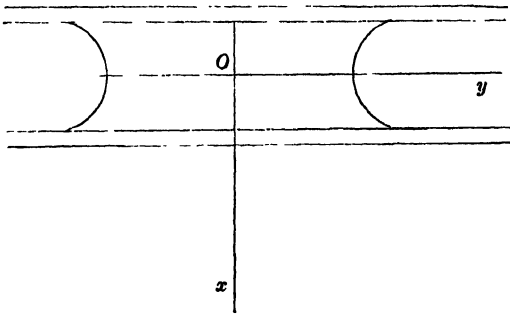

Measuring  $x$  downwards, as before, from the plane which is midway between the plates, the equation becomes

$$\frac{p \frac{dp}{dy}}{(1+p^2)^{\frac{3}{2}}} - \frac{1}{y(1+p^2)^{\frac{1}{2}}} = \frac{\varpi}{t} = \frac{2}{b}, \text{ say,}$$

leading to the equation

$$\frac{by}{(1+p^2)^{\frac{1}{2}}} = lb + l^2 - y^2,$$

from which we may deduce, as in the last article,

$$x = \zeta(\omega_2) - \zeta(u + \omega_2) + \frac{1}{3}(u - \omega_1)(l^2 + lb - b^2),$$

and

$$y^2 = -\varphi(u + \omega_2) + \frac{1}{3}(2l^2 + 2lb + b^2).$$

For a large drop, we obtain, as before,

$$r = h \sec \alpha,$$

$\alpha$  being the acute angle between the surface of the water and the surface of each plate.

**175. Floating needle.** The well-known experiment of floating a needle on the surface of water can be explained by aid of the laws of surface.

The figure representing a section of the needle and the surface of the water at right angles to the axis of the needle, the forces in action on the needle are the tensions on  $P$  and  $Q$ , and the water pressure on  $PAQ$ , which is equal to the weight of the volume  $NPAQM$  of water; these forces counterbalance the weight of the needle.

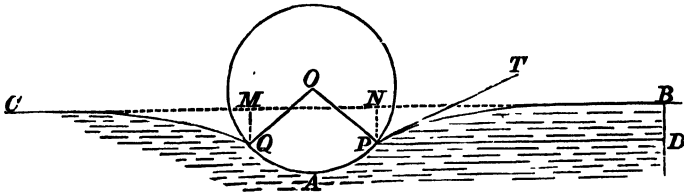

Further the horizontal component of the tension at  $P$ , together with the horizontal water pressure on  $BD$ , is equal to the tension at  $B$ ,  $PD$  being horizontal and  $BD$  vertical.

These conditions determine the equilibrium, and lead to the equations

$$2t \sin(\theta - \alpha) + g\rho c(c\theta + c \sin \theta \cos \theta - 2h \sin \theta) = w,$$

$$4t \sin^2 \frac{1}{2}(\theta - \alpha) = g\rho(c \cos \theta - h)^2,$$

where  $\alpha$  is the angle of capillarity,  $w$  the weight of unit length of the needle,  $h$  the height of its axis above the natural level of the water, and  $2\theta$  the angle  $POQ$ .

**176. Liquid films.** Liquid films are produced in various ways; a soap bubble is a familiar instance, and liquid films may be formed, and their characteristics observed, by shaking a clear glass bottle containing some viscous fluid, or by dipping a wire

frame into a solution of soap and water, or glycerine, and slowly drawing it out.

The fact that films apparently plane can be obtained, shews that the action of gravity may be neglected in comparison with the tension of the film.

It is found that a very small tangential action will tear the film, and it is therefore inferred that the stress across any line is entirely normal to that line. From this it follows, as in Art. (149), that the tension is the same in every direction.

**177. Energy of a plane film.** If a plane film be drawn out from a reservoir of viscous liquid, a certain amount of work is expended, and the work thus expended represents the potential energy of the film.

Imagine a rectangular film  $ABCD$ , bounded by straight wires  $AD, BC$ ;  $AB$  being in the surface of the liquid, and  $CD$  a moveable wire.

The work done in pulling out the film is equal to  $\tau \cdot AB \cdot AD$ , and therefore, if  $S$  be the superficial energy, per unit of area, it follows that

$$S = \tau.$$

It should be observed that what we have here called the tension of the film is equal to twice the surface tension of either side of the film.

**178.** *A wire in a vertical plane of any shape has a piece of thread, of given length and weight, fastened at two points, and the wire and the thread form the boundary of a plane liquid film.*

To find the form assumed by the thread, we shall express the condition that the potential energy of the system is a minimum.

If  $A$  be the area  $OABC$ , the energy of the film

$$= SA - \int S y dx,$$

and therefore if  $w$  be the weight of unit length of thread, the potential energy of the system is a minimum when

$$\int S y dx + w \int y ds$$

is a maximum, with the condition

$$\int ds = l.$$

We have then to find the condition that the variation of the expression

$$\int \{S y + (w y + \lambda) \sqrt{1 + p^2}\} dx$$

shall be evanescent.

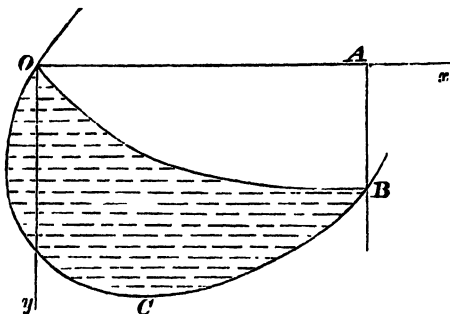

By the aid of the Calculus of Variations this leads to the equation

$$\sqrt{1 + p^2} = \frac{w y + \lambda}{C - S y};$$

$$\therefore \frac{dx}{dy} \text{ is of the form } \frac{a + by}{\sqrt{\alpha + \beta y + \gamma y^2}},$$

an expression which is easily integrated.

This equation may represent, for certain values of the constants, a circle or a catenary, as is obvious *a priori*.

**179.** The question can be otherwise treated by writing down the conditions of equilibrium of an element of the thread.

Measuring the arc from  $O$ , let  $\phi$  be the inclination to  $OA$  of the tangent at  $P$ .

Then, if  $t$  is the tension of the thread at  $P$ , and  $\tau$  the tension of the film, we obtain the equations

$$\delta t + w \delta s \cdot \sin \phi = 0,$$

$$\frac{t \delta s}{r} = \tau \delta s + w \delta s \cdot \cos \phi,$$

$r$  being the radius of curvature of the thread at  $P$ .

Hence 
$$\frac{dt}{dy} = -w, \quad t = w(a - y),$$

and 
$$\therefore \frac{-p \frac{dp}{dy}}{(1+p^2)^{\frac{3}{2}}} = \frac{1}{w(a-y)} \left( \tau + \frac{w}{(1+p^2)^{\frac{1}{2}}} \right).$$

Hence 
$$(a-y) \frac{d}{dy} (1+p^2)^{-\frac{1}{2}} - (1+p^2)^{-\frac{1}{2}} = \frac{\tau}{w},$$

so that 
$$\frac{a-y}{\sqrt{1+p^2}} = \frac{\tau y}{w} + C,$$

which is the form obtained in the preceding article.

In fact, if we assume that  $\phi = \alpha$ , when  $y = 0$ , and that  $\phi = \beta$ , when  $y = AB = k$ , the two unknown constants in each of the equations will be determined, and, observing that  $\tau = S$ , the same value of  $p$ , as a function of  $y$ , will result from each equation.

**180. Energy of a spherical soap bubble.** The energy of a soap bubble is the work done in producing it. This consists of two parts, viz. the work done in pulling out the film and the work done in compressing the air in the bubble.

If  $t$  be the surface tension, the former part is  $tS$ , where  $S$  denotes the surface, for the energy of a small plane element is  $t\delta S$ . For the latter part, let  $p$  denote the pressure of the air inside when the radius is  $r$ , and  $\Pi$  the atmospheric pressure, then  $p - \Pi = \frac{2t}{r}$ ; and, if the bubble contains a mass of air which at pressure  $\Pi$  would occupy a volume  $V$ , then

$$\Pi V = \frac{4}{3}\pi r^3 p = p V', \text{ say,}$$

and by Art. (14) the work done in compressing the air from volume  $V$  to volume  $V'$

$$\begin{aligned} &= \Pi V \log \frac{V}{V'} - \Pi (V - V') \\ &= \frac{4}{3}\pi r^3 \left\{ \left( \Pi + \frac{2t}{r} \right) \log \left( 1 + \frac{2t}{r\Pi} \right) - \frac{2t}{r} \right\}. \end{aligned}$$

we assume that the difference between the pressures inside and outside the bubble is small compared with the atmospheric pressure, we may take  $\frac{2t}{r\Pi}$  as small, and the last expression becomes

$$\begin{aligned} &\frac{4}{3}\pi r^3 \left\{ \left( \Pi + \frac{2t}{r} \right) \left( \frac{2t}{r\Pi} - \frac{2t^2}{r^2\Pi^2} \right) - \frac{2t}{r} \right\} \\ &= \frac{4}{3}\pi r^3 \cdot \frac{2t^2}{r^2\Pi} = \frac{8}{3} \frac{t^2 S}{r\Pi}, \end{aligned}$$

so that the work done in compressing the air is to that done in pulling out the film as  $2t : 3r\Pi$ .

**181. The forms of liquid films.** If the air pressure be the same on both sides of a film, the condition of equilibrium is that

$$\frac{1}{r} + \frac{1}{r'} = 0,$$

or that the mean curvature is zero.

This condition is satisfied in the cases of the catenoid and the helicoid, which are therefore possible forms of liquid films.

In Cartesian co-ordinates the equation becomes

$$\left\{1 + \left(\frac{\partial z}{\partial y}\right)^2\right\} \frac{\partial^2 z}{\partial x^2} - 2 \frac{\partial z}{\partial x} \frac{\partial z}{\partial y} \frac{\partial^2 z}{\partial x \partial y} + \left\{1 + \left(\frac{\partial z}{\partial x}\right)^2\right\} \frac{\partial^2 z}{\partial y^2} = 0,$$

as in Art. (145).

The discussion of this equation is the subject of many memoirs by eminent mathematicians, and several very remarkable special solutions have been obtained.

For instance, the surfaces

$$e^z = \frac{\cos y}{\cos x} \quad \text{and} \quad \sin z = \sinh x \sinh y$$

will be each found to possess the property that its mean curvature is zero\*.

In Plateau's work, *Sur les liquides soumis aux seules forces moléculaires* (2 vols. 1873), will be found an elaborate account of the labours of mathematicians on this subject, and of his own extensive series of experiments; and, in Darboux's *Théorie Générale des Surfaces*, Tome I., Livre III., there is a full discussion of minima surfaces, that is, of surfaces which satisfy the condition given above.

**182.** If the form of the film be that of a surface of revolution, then, taking the axis of the surface as the axis of  $z$ ,

$$r^2 = x^2 + y^2 = f(z).$$

The vanishing of the mean curvature in this case gives

$$0 = \frac{1}{\rho} + \frac{1}{\rho'} = \frac{-\frac{d^2 r}{dz^2}}{\left\{1 + \left(\frac{dr}{dz}\right)^2\right\}^{\frac{3}{2}}} + \frac{1}{r \left\{1 + \left(\frac{dr}{dz}\right)^2\right\}^{\frac{1}{2}}},$$

\* Catalan, *Journal de l'École Polytechnique*, 1856.

or 
$$r \frac{d^2 r}{dz^2} = 1 + \left( \frac{dr}{dz} \right)^2.$$

Integrating,

$$\frac{dz}{dr} = \frac{a}{\sqrt{r^2 - a^2}}, \text{ and } \therefore z + b = a \log (r + \sqrt{r^2 - a^2}),$$

or 
$$2r = e^{\frac{z+b}{a}} + a^2 e^{-\frac{z+b}{a}}.$$

Assuming 
$$e^{\frac{b}{a}} = a e^{\frac{h}{a}},$$

the result is 
$$2r = a \left( e^{\frac{z+h}{a}} + e^{-\frac{z+h}{a}} \right),$$

shewing that a catenoid is the only possible form of revolution of a film when the pressure is the same on both sides.

**183.** The same result is obtained by the principle of energy, for the surface

$$\int 2\pi y ds$$

is then a maximum or a minimum, and, by the Calculus of Variations, this leads to a catenary as the generating curve, the axis of revolution being the directrix of the catenary.

In Todhunter's *Researches in the Calculus of Variations* it is shewn that it is not always possible, when a straight line and two points in the same plane are given, to draw a catenary which shall pass through the two points and have the straight line for its directrix.

It is also shewn that, under certain conditions, two such catenaries can be drawn, and that, in a particular case, only one such catenary can be drawn. The two catenaries, when they exist, correspond to the figure formed by a uniform endless string hanging over two smooth pegs.

When there are two catenaries the surface generated by the revolution of the upper one about the directrix is a minimum, but the surface generated by the lower one is not a minimum. When there is only one catenary, it is not a minimum.

Hence it appears that if a framework be formed of two circular wires, the planes of which are parallel to each other and perpendicular to the line joining their centres, it is not always possible to connect the wires by a liquid film. In certain cases it is possible to connect the wires by one of two catenoids, but, in the case of the catenoid formed by the revolution of the upper

catenary, the equilibrium is stable, while the other catenoid is unstable.

When there is only one catenoid it is unstable.

There is also a discontinuous solution of the problem, consisting of the two circles formed by the revolution of the ordinates of the points, and an infinitesimally slender cylinder connecting their centres.

In the article on Capillarity in the *Encyclopaedia Britannica*\* by Clerk Maxwell, the question is discussed in the following manner.

When two catenaries, having the same directrix, can be drawn through two given points, and the catenoids are formed by revolution about the directrix, the mean curvature of each catenoid is zero.

If another catenary be drawn between the two catenaries, passing through the same two points, its directrix will be above the directrix of the other two, and therefore its radius of curvature at any point will be less than the distance, along the normal, of the point from the first directrix.

The mean curvature of the surface of revolution is therefore convex to the axis, and it follows that if either catenoid is displaced into another catenoid between the two, the film will move away from the axis.

Again, if a catenoid be taken outside the two, its mean curvature will be concave to the axis, and therefore if the upper catenoid be displaced upwards and the lower one downwards the film will, in each case, move towards the axis.

Hence it follows that the outer of the two catenoids is stable, and that the inner one is unstable.

This argument however does not apply to any other form of displacement, and therefore, for a complete proof of the case of stability, it is necessary to have recourse to the methods of the Calculus of Variations.

**184.** If the pressures on the two sides of a film be different, and if  $p$  be the difference, the condition of equilibrium is

$$\frac{1}{r} + \frac{1}{r'} = \frac{p}{t},$$

or that the mean curvature is constant.

\* This article has been revised by Lord Rayleigh in the eleventh edition of the *Encyclopaedia*.

We shall apply the principle of energy to prove this relation for the case of surfaces of revolution.

The fact that  $p$  is constant may be expressed by closing the ends and assuming that the volume of air inside is constant.

The variation of the expression

$$\int (2\pi y ds + \lambda \pi y^2 dx)$$

is therefore zero.

This leads to

$$\frac{dx}{ds} = \frac{c}{y} - \frac{\lambda y}{2}, \text{ and } \therefore \frac{d^2x}{ds^2} = \left(-\frac{c}{y^2} - \frac{\lambda}{2}\right) \frac{dy}{ds}.$$

Hence, if  $PG$  be the normal,

$$\frac{1}{PG} \pm \frac{1}{r} = -\lambda, \text{ since } \frac{d^2x}{ds^2} = \mp \frac{1}{r} \frac{dy}{ds},$$

according as the curve is convex or concave to the axis of  $x$ ; that is the mean curvature is constant. And, in the general case, we have to express the condition that the surface is a maximum or a minimum with a given volume, leading to the same general result\*.

**185.** If the film be in the form of a surface of revolution, we can shew that the meridian curve is the path of the focus of a conic rolling on a straight line.

If  $\rho$  be the radius of curvature of the conic, and  $r$  the radius of curvature of the path of  $S$ ,

$$\begin{aligned} \frac{1}{r} &= \frac{1}{SP} - \frac{\rho \cos SPG}{SP^2} \quad \dagger \quad (\text{see figure on next page}) \\ &= \frac{1}{SP} - \frac{PG^2}{PL \cdot SP^2}, \quad (GL \text{ being perpendicular to } SP, \\ &= \frac{1}{SP} - \frac{PL}{SY^2}, \\ \therefore \frac{1}{r} + \frac{1}{SP} &= \frac{2}{SP} - \frac{PL}{SY^2}. \end{aligned}$$

In the case of the parabola, this vanishes, and  $r = -SP$ .

\* See Jellet's *Calculus of Variations*, or Todhunter's *Integral Calculus*.

† See *Roulettes and Glissettes*.

For the ellipse,  $\frac{SY^2}{SP^2} = \frac{BC^2}{SP \cdot HP}$ , and  $\frac{1}{r} + \frac{1}{SP} = \frac{1}{AC}$ ,

and for the hyperbola,  $\frac{1}{r} + \frac{1}{SP} = -\frac{1}{AC}$ .

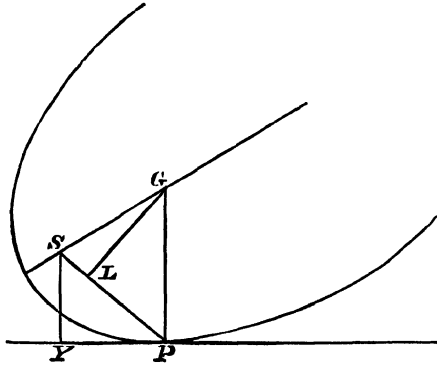

The first is the Catenoid; the second and third are called by Plateau the Unduloid, and the Nodoid, the former being a sinuous curve, and the latter presenting a succession of nodes.

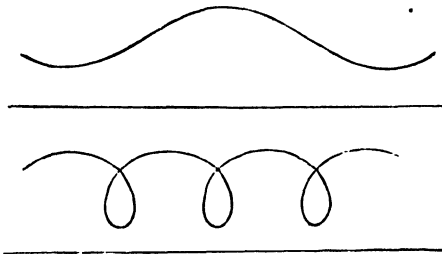

To obtain a clear view of the generation of the nodoid, it must be considered that, as one branch of the hyperbola rolls, the point of contact moves off to an infinite distance; the line then becomes asymptotic to both branches, and the other branch begins to roll, thereby producing a perfect continuity of the figure\*.

Of the numerous works and papers on the subject of liquid films the student will find full accounts in Plateau's work, and in Professor Clerk Maxwell's article in the *Encyclopaedia Britannica*;

\* Plateau, Vol. I, p. 136. See also an article by Delaunay, *Liouville's Journal*, 1841, and an article by Lamarle, *Bulletins de l'Académie Belgique*, 1857.

and on the subject of Capillarity generally the following works and references may be useful:

Mathieu, *Théorie de la Capillarité*, 1883.

F. Neumann, *Vorlesungen über die Theorie der Capillarität*, 1894.

Poincaré, *Capillarité*, 1895.

The articles *Kapillarität* by H. Minkowski in *Encyklop. der Math. Wissensch.* Bd. v. 1907, and by F. Pockels in *Winkelmann's Handbuch der Physik*, Bd. i. 1908, both of which contain a full bibliography of the subject.

EXAMPLE. A soap bubble extends from fixed boundaries, so as with them to form a closed space whose volume is  $v_0$ , and contains a gas at pressure  $p_0$  and absolute temperature  $\theta_0$ . The temperature of the gas is gradually raised. If  $A$  be the area of the film when the temperature is  $\theta$ , and pressure  $p$ , shew that

$$t\theta_0 \frac{dA}{d\theta} = p_0 v_0 \left(1 - \frac{\theta}{p} \frac{dp}{d\theta}\right),$$

where  $t$  is the surface tension supposed constant, and the external pressure is neglected. Deduce the relation between  $p$  and  $\theta$  when the bubble is spherical.

The change of energy =  $t\delta A$

$$= p\delta v.$$

But  $p v = k\theta$ ;

$$\therefore p\delta v = k\delta\theta - v\delta p;$$

$$\begin{aligned} \therefore t \frac{dA}{d\theta} &= k - v \frac{dp}{d\theta} \\ &= k \left(1 - \frac{\theta}{p} \frac{dp}{d\theta}\right) \\ &= \frac{p_0 v_0}{\theta_0} \left(1 - \frac{\theta}{p} \frac{dp}{d\theta}\right). \end{aligned}$$

For a sphere  $A = 4\pi r^2$ , and  $p = \frac{2t}{r}$ ;

$$\therefore A = 16\pi t^2 / p^2.$$

Hence from above

$$\begin{aligned} -32\pi \frac{t^3}{p^3} \frac{dp}{d\theta} &= k \left(1 - \frac{\theta}{p} \frac{dp}{d\theta}\right); \\ \therefore -2 \frac{At}{p} \frac{dp}{d\theta} &= k \left(1 - \frac{\theta}{p} \frac{dp}{d\theta}\right), \end{aligned}$$

but

$$\begin{aligned} p v &= k\theta; \\ \therefore \frac{1}{3} p r A &= k\theta \text{ or } \frac{2}{3} t A = k\theta; \\ \therefore -\frac{3k\theta}{p} \frac{dp}{d\theta} &= k - \frac{k\theta}{p} \frac{dp}{d\theta}; \\ \therefore \frac{2\theta}{p} \frac{dp}{d\theta} + 1 &= 0; \\ \therefore p^2 \theta &= \text{constant.} \end{aligned}$$

## EXAMPLES

1. Two spherical soap bubbles are blown, one from water, and the other from a mixture of water and alcohol : if the tensions per linear inch are equal to the weights of one grain and  $\frac{7}{13}$  grain respectively, and if the radii be  $\frac{7}{8}$  inch and  $1\frac{1}{3}$  inch respectively, compare the excess, in the two cases, of the total internal over the total external pressure.

2. If two soap bubbles of radii  $r$  and  $r'$ , are blown from the same liquid, and if the two coalesce into a single bubble of radius  $R$ , prove that, if  $\Pi$  be the atmospheric pressure, the tension is equal to

$$\frac{\Pi}{2} \frac{R^3 - r^3 - r'^3}{r^2 + r'^2 - R^2}$$

3. The superficial tensions of the surfaces separating water and air being 8.25, water and mercury 42.6, mercury and air 55, what will be the effect of placing a drop of water upon a surface of mercury ?

4. A drop of oil, placed on the surface of water, at once spreads itself out into a layer of extreme tenuity; explain the cause of this expansion of the oil, and prove, from observation of an attendant phenomenon, that the thickness of the layer may become less than .00001 of an inch.

What will take place if another drop of oil is placed on the surface ?

5. Shew that if a light thread with its ends tied together form part of the internal boundary of a liquid film, the curvature of the thread at every point will be constant.

If the thread have weight, and if the film be a surface of revolution about a vertical axis, prove that, in the position of equilibrium, the tension of the thread is

$$\frac{l}{2\pi} \sqrt{\tau^2 - w^2},$$

$l$  being its length,  $w$  its weight per unit length, and  $\tau$  the tension of the film.

6. A plane liquid film is drawn out from a soap-sud reservoir ; prove that the numerical value of the energy per unit of area ( $e$ ) is equal to that of the tension ( $T$ ) per unit of length.

If the film be removed from the reservoir, and if  $\sigma$  denote subsequently the mass of unit of area, prove that

$$T = e - \sigma \frac{de}{d\sigma}. \quad (\text{Clerk Maxwell.})$$

7. Any number of soap bubbles are blown from the same liquid and then allowed to combine with one another. Find an equation for determining the radius of the resulting bubble, and prove that the decrease of surface bears a constant ratio to the increase of volume.

8. The surface tension of water exposed to air is such that the stress across an inch is equal to the weight of about 3.3 grains. If 1,000,000,000 spherical drops combine to form a single spherical rain-drop  $\frac{1}{10}$  inch in diameter, shew that the work done by the surface tensions is equal to about .0001277 foot-pounds.

9. If a film under unequal internal and external pressure form a surface of revolution, prove that the inclination  $\phi$  of the tangent plane at  $P$  to the axis is given by the equation

$$\cos \phi = \frac{x}{a} + \frac{b}{x} :$$

$x$  being the perpendicular from  $P$  on the axis and  $a, b$  constants.

10. A drop of liquid with uniform surface tension is made to revolve about an axis. Prove that the meridian curve of the surface will be the roulette of the pole of the curve

$$\frac{p^2}{c^2} = \frac{2a}{r} - 1.$$

11. Two soap bubbles are in contact; if  $r_1, r_2$  be the radii of the outer surfaces, and  $r$  the radius of the circle in which the three surfaces intersect,

$$\frac{3}{4r^2} = \frac{1}{r_1^2} + \frac{1}{r_2^2} - \frac{1}{r_1 r_2}.$$

12. If a frame of fine straight wire in the form of a tetrahedron be lowered into a solution of soap and water and drawn up again, there are found in certain cases plane films starting from the edges and meeting in a point. Shew that this is not a possible form of equilibrium for every tetrahedron, and that it is so if one face be an equilateral triangle and the others isosceles triangles, whose vertical angles are each less than  $\sec^{-1}(-3)$ .

13. If water be introduced between two parallel plates of glass, at a very small distance  $d$  from each other, prove that the plates are pulled together with a force equal to

$$\frac{2At \cos \alpha}{d} + Bt \sin \alpha,$$

$A$  being the area of the film and  $B$  its periphery.

14. A hollow right circular cone of glass is placed with its axis vertical and vertex upwards in homogeneous liquid. Find the height to which the liquid will be raised in the cone, and write down the differential equation of the surface inside. Deduce results for a cylinder.

15. A needle floats on water with its axis in the natural level of the surface; if  $\sigma$  be the specific gravity of steel referred to water,  $\beta$  the angle of capillarity, and  $2a$  the angle subtended at the axis by the arc of a cross-section in contact with the water, prove that

$$(\pi\sigma - a) \sin \frac{1}{2}(a - \beta) = \cos a \cos \frac{1}{2}(a + \beta).$$

16. A capillary tube in the form of a surface of revolution is partly immersed in a liquid with its axis vertical. Find the equation of the generating curve if the liquid is in equilibrium at whatever height it stands in the tube.

17. A soap bubble is filled with a mass  $m$  of a gas whose pressure is  $k \times$  (its density) at the temperature considered. The radius of the bubble is  $a$ , when it is first placed in air. The barometer then rises, the temperature remaining unaltered. Shew that the radius of the bubble increases or diminishes according as the tension of the film is greater or less than  $\frac{9}{8} \frac{km}{\pi a^2}$ .

18. Prove that the equation

$$y = x \tan (ax + b)$$

represents a possible form of a liquid film, the pressure on both sides being the same.

19. If two needles floating on water be placed symmetrically parallel to each other, shew that they will be apparently attracted to each other, and that this is due to the surface tension.

20. A small cube floats with its upper face horizontal, in a liquid such that its angle of contact with the surface of the cube is obtuse and equal to  $\pi - \alpha$ . If  $\rho$  is the density of the liquid, and  $\sigma$  that of the cube, and if  $g\rho c^2$  is the surface tension, prove that the cube will float if

$$\frac{\sigma}{\rho} < 1 + 4 \frac{c^2}{a^2} \cos \alpha + 2 \frac{c}{a} \sin \left( \frac{\pi}{4} - \frac{\alpha}{2} \right).$$

21. Two equal circular discs of radius  $a$  are placed with their planes perpendicular to the line which joins their centres, and their edges are connected by a soap film which encloses a mass of air that would be just sufficient in the same atmosphere to fill a spherical soap bubble of radius  $c$ . If the film be cylindrical when the distance between the discs is  $b$ , prove that in order that it may become spherical the distance between the discs must be lessened to  $2z$ , where

$$c(3a^2 + 2z^2) \left\{ 8c^2 - 3ab + \frac{6a^2b - 8c^3}{\sqrt{a^2 + z^2}} \right\} = 6abc^2(2a - c).$$

22. A framework of wires forms a prism of height  $b$ , the bases being equilateral triangles of side  $a$ . If the framework is dipped into soapy water, describe the arrangement of plane films in the state of equilibrium. Prove that for equilibrium to be possible with plane films  $b$  must be greater than  $a/\sqrt{6}$ .

23. A film of fluid adheres to two wires each of which forms one turn of a helix, the axes of the two helices being coincident, and their steps equal. Shew that the condition of equilibrium of the film will be satisfied if the differential equation to any section of the film through the axis is of the form

$$dx = \frac{A dy}{y} \sqrt{\frac{a^2 + y^2}{y^2 - A^2}}$$

when  $2\pi a =$  step of either helix (i.e. distance between consecutive threads).

24. To the extremities of the axis of a wire helix of pitch  $b$ , whose length is very great compared with its diameter, an elastic string (modulus of elasticity  $E$ ) is fastened, the wire being bent over radially at each end so as to meet the axis. The string when straight is tight but unstretched. If the helix and string be dipped into a solution of soap and then removed with a film adhering to the wire and string, shew that, except near the ends, the string will be drawn into a helix of radius  $r$  where  $r$  is given by the equation

$$(16\pi^4 h^2 T^2 - 64\pi^0 E^2) r^4 + 32\pi^4 h^2 T E r^3 + 8\pi^2 h^4 T^2 r^2 + 8\pi^2 h^4 T E r + h^6 T^2 = 0,$$

$T$  representing the whole tension per unit of length (of both surfaces) of a soap film.

25. A plane plate is partly immersed in a liquid of density  $\rho$  and surface tension  $t$ . The angle of capillarity for the liquid and substance of the plate is  $\beta$ , and the plate is inclined at an angle  $\alpha$  to the horizontal. Prove that the difference of the heights of the liquid on the two sides of the plate above the undisturbed surface level is

$$.4 \left\{ \frac{t}{g\rho} \right\}^{\frac{1}{2}} \cos \frac{\pi - 2\beta}{4} \sin \frac{\pi - 2\alpha}{4}.$$

26. A framework  $ABCD$  is formed of three straight wires  $AB$ ,  $BC$ ,  $CD$  joined by an arc of a helix  $DA$  of angle  $\frac{\pi}{4}$ ,  $BC$  being the axis and  $AB$ ,  $CD$  radii of length  $a$ . Prove that, if the frame be dipped into a soap solution, a film will be formed whose surface energy is

$$\frac{T a^2 a}{2} \{ \sqrt{2} + \log(\sqrt{2} + 1) \},$$

where  $T$  is the surface tension and  $\alpha$  the small inclination of  $AB$  to  $CD$ .

27. A fluid of density  $\rho$  and surface tension  $T$  is drawn up within a fine capillary tube of radius  $a$ , with which the angle of contact is  $\alpha$ . Shew that, if  $T = g\rho c^2$ , the height to which the fluid rises at the circumference of the tube is

$$\frac{2c^2}{a} \cos \alpha + \frac{a}{3} (2 \sec^3 \alpha - 2 \tan^3 \alpha - 3 \tan \alpha),$$

where the third and higher powers of  $a/c$  are neglected.

28. A volume  $\frac{4}{3}\pi c^3$  of gravitating liquid of astronomical density  $\rho$  is surrounded by an atmosphere at pressure  $\Pi$  and contains a concentric cavity filled with air, whose volume at this atmospheric pressure is  $\frac{4}{3}\pi a^3$ . The surface tension of the liquid is  $t$ . Prove that the radius  $x$  of the cavity in the configuration of equilibrium is given by the equation

$$\Pi \left( \frac{a^3}{x^3} - 1 \right) = 2t \left\{ \frac{1}{x} + \frac{1}{2(c^3 + x^3)} \right\} + \frac{2}{3} \pi \rho^2 \left\{ \frac{c^4 + 3cx^3}{2(c^3 + x^3)} - 3x^2 \right\}.$$

29. If a mass of liquid of density  $\rho$  is in equilibrium under the action of a conservative system of forces whose potential at any point is  $\mu/r$ , where  $r$  is the distance from a fixed point  $O$ , and if two parallel plates of glass are placed in the liquid with their nearer faces at very small distances  $\frac{1}{2}c$  on opposite sides of  $O$ , and have small apertures opposite  $O$  through which the liquid can flow, prove that  $a, b$ , the radii of the inside and outside circular areas of either plate wetted by the liquid, are connected by the equation

$$\mu c \rho (1/a - 1/b) = S \cos \alpha,$$

where  $\alpha$  is the angle the air-liquid surface makes with the glass, and  $S$  is the capillary constant.

30. A large glass plate is lifted from the surface of a liquid so that the liquid is drawn up to a height  $h$ , and  $\beta$  is the complement of the angle of contact at the under surface of the plate. Prove that the radius of the circle wetted by the liquid is approximately

$$\frac{1}{3} b^3 (1 - \cos^2 \frac{1}{2}\beta) / (h^2 - b^2 \sin^2 \frac{1}{2}\beta),$$

where  $b^2 = 4T/g\rho$ ,  $T$  being the surface tension, and  $\rho$  the density of the liquid.

31. A liquid film hangs in the form of a surface of revolution with its axis vertical. The upper boundary of the film is a circular wire held horizontally, the lower boundary is a heavy elastic thread, hanging freely in the form of a horizontal circle of radius  $r$ . The natural length of the thread is  $2\pi a$ , its modulus of elasticity is  $\lambda$ , and its weight is  $2\pi a w$ . The tension of the film is  $t$ . Prove that  $r$  satisfies the equation

$$(\lambda^2 - a^2 t^2) r^2 - 2\lambda^2 a r + (\lambda^2 + w^2 a^2) a^2 = 0.$$

32. A liquid film is bounded externally by a closed rigid wire, not necessarily in the form of a plane curve, and contains as internal boundary an endless flexible thread. Prove that the radius of curvature of the thread at any point is constant, and that the radius of torsion is numerically equal to either of the radii of principal curvature of the film at that point.

33. A wire circle (radius  $a$ ) is placed in the surface of soapy water and raised gently, so as to draw after it a film. Prove that, neglecting its weight, the meridian section of the film is a catenary, and investigate the angle at which the film meets the undisturbed surface of the water. Also prove that the parameter of the meridian catenary, when the area of the film is equal to  $\pi a^2$ , is  $a/z$ , where  $z$  is given by

$$\cosh^{-1} z + z(z^2 - 1)^{\frac{1}{2}} = z^2.$$

34. When the end of a capillary tube is dipped into water, the water is observed to rise to a height  $h$ ; the tube is withdrawn from the water, and a drop of radius  $r$  is formed at its extremity. If  $h'$  be the height of the suspended water, measured from the bottom of the drop to the top of the column in the tube, prove that the surface tension is given by the formula

$$2T/g\rho = r(h' - h) - \frac{1}{3}r^2,$$

$\rho$  denoting the density, and it being assumed that the drop is of spherical form.

35. Two circular rings with a common axis at right angles to their planes support a closed liquid film containing air at a greater pressure than the external air: shew that the ends of the film are spheres of radius  $a = \frac{2T}{\rho}$  and that the surface between the rings is a surface of revolution of which the meridian curve has an intrinsic equation  $\sin \phi = \frac{x}{a} \pm \frac{b}{x}$ , where  $\phi$  is the inclination of the normal to the axis and  $x$  is the distance from the axis.

36. Prove that, if fluid be drawn up by capillary action between two parallel vertical plates, the elevation at any point of the free surface above the undisturbed level is  $h/dn(2s/kc)$ , where  $h$  is the elevation of the vertex,  $s$  the arc of the free surface measured from the vertex, the surface tension,  $T$ , is  $\frac{1}{2}g\rho c^2$ , and the modulus  $k=c/(h^2+c^2)^{\frac{1}{2}}$ .

37. A long circular cylinder of radius  $r$  entirely immersed in liquid, whose acute angle of contact with it is  $a$ , is gradually made to emerge, its axis being kept horizontal. Shew that contact with the liquid finally ceases when the axis reaches a height  $h$  above the original and ultimate level of the liquid given by the equations

$$h = r \cos(\phi - a) + c \cos \frac{\phi}{2},$$

$$\frac{2r}{c} \sin(\phi - a) + 2 \sin \frac{\phi}{2} - \tanh^{-1} \sin \frac{\phi}{2} = 2 \sin \frac{\pi}{4} - \tanh^{-1} \sin \frac{\pi}{4},$$

the ratio of the surface tension to the density of the liquid being  $\frac{1}{2}gc^2$ .

38. A drop of water hangs from the lower surface of a horizontal plate of glass; if  $\mu$  be the ratio of the surface tension to the specific weight of water, and  $u = \frac{1}{2}\mu(d\phi/ds)^2$ , where  $s$  is the arc of the meridian curve of the drop, and  $\phi$  is the angle the tangent to the meridian curve makes with the horizontal, prove that

$$(\sin \phi + u')(2 \sin \phi + 3u'')^2 = 2u \tan \phi (\sec \phi + \tan \phi \cdot u' + u'')$$

$$\left( \frac{2 + \sec^2 \phi}{\sec \phi} + \frac{2 + \sec^2 \phi}{\tan \phi} u' + u'' \right),$$

where  $u' = du/d\phi$ ,  $u'' = d^2u/d\phi^2$ . If the square of  $\mu$  be neglected, prove that the square of the curvature of the meridian curve is

$$\frac{4}{\mu} \frac{e^{-x}}{e^x x^{3/5}} \int_{x_1}^{x_2} \frac{e^{-x} dx}{x(1+16x)^{3/5} x^{3/5}},$$

where  $x = \frac{1}{16} \tan^2 \phi$ , and  $x_1$  is the value of  $x$  at the point of inflexion.

39. A long wedge of vertical angle  $2a$ , floats in water with its base horizontal and its top edge in the natural level of the surface. Prove that, if the capillary action at the ends be neglected,

$$w - w' = 2T \sec a (\sin a + \cos \gamma),$$

where  $w$  is the weight of the wedge per unit length,  $w'$  that of an equal volume of water,  $T$  the surface tension and  $\gamma$  the supplement of the angle of capillarity.

40. A drop of mercury of volume  $V$  under no external forces is pressed between two parallel glass plates at distance  $h$ ,  $t$  being the surface tension, and  $i$  the angle of contact for glass and mercury. Shew that the magnitude of the pressure required is

$$2\pi t a k' / (1 - k'),$$

where

$$h = 2a \int_0^\mu (\text{dn}^2 u - k') du, \quad V = 2\pi a^3 \int_0^\mu (\text{dn}^2 u - k') \text{dn}^2 u du,$$

and

$$k' = \Delta \left( \frac{\pi}{2} \right) = \text{cotam } \mu \cot (i + \text{am } \mu).$$

Shew that when the plates are very close together, the value of the pressure is, to a first approximation,

$$\frac{2 V t \cos i}{h^2}.$$

41. A drop of fluid under no forces except uniform external pressure and surface tension rotates as a rigid body about an axis; shew that on the surface  $3/R_2 - 1/R_1$  is constant, where  $R_1, R_2$  are the principal radii of curvature of the surface.

42. Prove that, when the axis of  $z$  is along a downward vertical, and the origin suitably chosen, the surface of separation of two fluids of densities  $\mu_1, \mu_2$  satisfies the relation

$$2z = a^2 (\rho^{-1} + \rho'^{-1}),$$

where  $\rho, \rho'$  are the principal radii of curvature taken positive when the concavity is downwards,  $a^2 = 2T/\{g(\mu_1 - \mu_2)\}$ , and  $T$  is the capillary constant of the interface.

If the surface is one of revolution about the  $z$  axis, shew that the approximate equation (in cylindrical coordinates) of the part near the axis is of the form

$$2(z - z_0) = z_0 r^{-2} r^2 + \frac{1}{8} (z_0 a^2 + 2z_0^3) a^{-6} r^4,$$

and indicate how, in the case of liquid in a tube,  $z_0$  can be expressed in terms of the angle of contact.

## CHAPTER XI

### THE EQUILIBRIUM OF REVOLVING LIQUID, THE PARTICLES OF WHICH ARE MUTUALLY ATTRACTIVE

**186.** IF a liquid mass, the particles of which attract each other according to a definite law, revolve uniformly about a fixed axis, it is conceivable that, for a certain form of the free surface, the liquid particles may be in a state of relative equilibrium; since, however, the resultant attraction of the mass upon any particle depends in general upon its form, which is unknown, a complete solution of the problem cannot be obtained.

For any arbitrarily assigned law of attraction, the question is one of purely abstract interest, and it is only when the law is that of gravitation that it becomes of importance, from its relation to one of the problems of physical astronomy.

We shall consider the fluid homogeneous, and confine our attention to two cases; in the first of these the attractive forces are supposed to vary directly as the distance, and, in the second, to follow the Newtonian law.

**187.** *A homogeneous liquid mass, the particles of which attract each other with a force varying directly as the distance, rotates uniformly about an axis through its centre of mass; required to determine the form of the free surface.*

The resultant attraction on any particle is in the direction of, and proportional to, the distance of the particle from the centre of mass; and if  $\mu$  be a measure of the whole mass of fluid,  $\mu x$ ,  $\mu y$ ,  $\mu z$  may represent the components of the attraction, parallel to the axis, on a particle of fluid about the point  $x$ ,  $y$ ,  $z$ .

Taking the origin at the centre of gravity, and axis of rotation as the axis of  $z$ , the equation of equilibrium is

$$dp = \rho \{(\omega^2 x - \mu x) dx + (\omega^2 y - \mu y) dy - \mu z dz\};$$

and therefore

$$p = C + \frac{1}{2}\rho \{(\omega^2 - \mu)(x^2 + y^2) - \mu z^2\}.$$

At the free surface  $p$  is zero or constant, and the equation to the free surface is

$$\left(1 - \frac{\omega^2}{\mu}\right) (x^2 + y^2) + z^2 = D,$$

the constant  $D$  depending upon  $\omega$ , and upon the mass of the fluid.

When  $\omega$  is very small, the free surface is nearly spherical, and as  $\omega^2$  increases from 0 to  $\mu$ , the spheroidal surface becomes more oblate.

When  $\omega^2 = \mu$ , the free surface consists of two planes; to render this possible we may conceive the fluid enclosed within a cylindrical surface, the axis of which coincides with the axis of rotation.

When  $\omega^2 > \mu$ , the free surface is a hyperboloid of two sheets, which for a certain value ( $\omega'$ ) of  $\omega$  becomes a cone, the fluid filling the space between the cone and the cylinder. Taking account of the volume of the fluid, the value of  $\omega'$  can be determined by putting  $D = 0$ , since the pressure in this case vanishes at the origin.

If  $\omega > \omega'$ , the surface is a hyperboloid of one sheet, which, as  $\omega$  increases, approximates to the form of a cylinder, and it is therefore necessary, for large values of  $\omega$ , to conceive the containing cylinder closed at its ends.

The results of this article, it may be observed, are equally true of heterogeneous fluid, whatever be the law of variation of density in the successive strata.

**188.** *A mass of homogeneous liquid, the particles of which attract each other according to the Newtonian law, rotates uniformly, in a state of relative equilibrium, about an axis through its centre of mass; required to determine a possible form of the surface.*

For the reason previously mentioned a direct solution of this problem cannot be obtained, but it can be shewn that an oblate spheroid is a possible form of equilibrium.

Let the equation to the spheroid be

$$\frac{z^2}{c^2} + \frac{x^2 + y^2}{c^2(1 + \lambda^2)} = 1,$$

the axis of rotation being the axis of  $z$ .

Then the resultant attractions, towards the origin, on a particle at the point  $(x, y, z)$  will be represented by

$$X = \frac{2\pi\rho x}{\lambda^3} \{(1 + \lambda^2) \tan^{-1} \lambda - \lambda\},$$

$$Y = \frac{2\pi\rho y}{\lambda^3} \{(1 + \lambda^2) \tan^{-1} \lambda - \lambda\},$$

$$Z = \frac{4\pi\rho z}{\lambda^3} \{\lambda - \tan^{-1} \lambda\} (1 + \lambda^2),$$

parallel, respectively, to the axes\*.

The equation of equilibrium is

$$dp = \rho \{(\omega^2 x - X) dx + (\omega^2 y - Y) dy - Z dz\}.$$

But from the equation to the spheroid,

$$x dx + y dy + (1 + \lambda^2) z dz = 0,$$

and as this must be a surface of equipressure, we must have

$$\omega^2 - X/x = \omega^2 - Y/y = -Z/(1 + \lambda^2) z.$$

Hence we get

$$\frac{\omega^2}{2\pi\rho} = \frac{(1 + \lambda^2) \tan^{-1} \lambda - \lambda}{\lambda^3} - \frac{2(\lambda - \tan^{-1} \lambda)}{\lambda^3},$$

or 
$$\frac{\omega^2}{2\pi\rho} = \frac{(3 + \lambda^2) \tan^{-1} \lambda - 3\lambda}{\lambda^3} \dots\dots\dots(\alpha).$$

If  $\omega$  and  $\rho$  are given, this equation determines  $\lambda$  and thence the ratio of the semiaxes of the spheroid is known.

To investigate the real solutions, let

$$y = \frac{(3 + x^2) \tan^{-1} x - 3x}{x^3} \dots\dots\dots(\beta).$$

Substituting the series for  $\tan^{-1} x$ , which is known to be convergent when  $x < 1$ , we get

$$y = \sum_1^{\infty} (-)^{n-1} \frac{4n}{(2n+1)(2n+3)} x^{2n} \dots\dots\dots(\gamma).$$

Also 
$$\begin{aligned} \frac{dy}{dx} &= \frac{(7x^2 + 9)}{x^3(x^2 + 1)} - \frac{(x^2 + 9)}{x^4} \tan^{-1} x \\ &= \frac{x^2 + 9}{x^4} \left\{ \frac{7x^3 + 9x}{(x^2 + 1)(x^2 + 9)} - \tan^{-1} x \right\} \dots\dots(\delta) \\ &= \frac{x^2 + 9}{x^4} f(x), \end{aligned}$$

\* These expressions will be found in Laplace's *Mécanique Céleste*, Poisson's *Mécanique*, Duhamel's *Mécanique*, and Todhunter's *Statics*. In the last named, the equation to the spheroid is  $(x^2 + y^2) a^2 + z^2/a^2(1 - e^2) = 1$ , but the expressions used in the text will result from the expressions there given by putting  $1 - e^2 = 1/(1 + \lambda^2)$ .

By the use of  $\lambda$ , irrational quantities are avoided. Equivalent forms are given in Kelvin and Tait's *Natural Philosophy*, § 527, and Routh's *Analytical Statics*, Vol. II. § 219.

where 
$$f(x) = \frac{7x^3 + 9x}{(x^2 + 1)(x^2 + 9)} - \tan^{-1} x.$$

The forms ( $\gamma$ ) and ( $\beta$ ) shew that  $y$  vanishes for  $x = 0$ , and  $x = \infty$ , respectively; we shall shew that as  $x$  increases from zero  $y$  has one maximum value and only one.

The sign of  $\frac{dy}{dx}$  depends only on that of  $f(x)$ ,

also when  $x = 0, \quad f(x) = 0,$

and when  $x = \infty, \quad f(x) = -\frac{\pi}{2}.$

Again, we find that

$$f'(x) = \frac{8x^4(3 - x^2)}{(x^2 + 1)^2(x^2 + 9)^2},$$

and this is positive from  $x = 0$  to  $x = \sqrt{3}$ , and negative for all greater values of  $x$ , so that  $f(x)$  begins by being positive and increases as  $x$  increases to  $\sqrt{3}$  and then decreases continuously;  $f(x)$  therefore vanishes for a value of  $x$  greater than  $\sqrt{3}$ . By the help of tables we can easily shew that  $f(2)$  is positive and  $f(3)$  negative, so that the value lies between 2 and 3. Also  $f(2.5) = .0025$  approximately, and Newton's method of approximation gives for the root  $2.5 - \frac{f(2.5)}{f'(2.5)} = 2.5 + .0293 = 2.5293\dots$

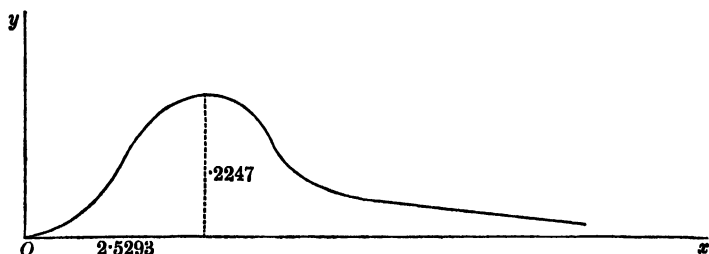

Hence  $\frac{dy}{dx}$  vanishes only when  $x = 2.5293\dots$  and  $y$  is then a maximum and its value is  $.2247$ .

The graph of equation ( $\beta$ ) is therefore as in the figure, in which however the ordinate is drawn on a larger scale than the abscissa.

We conclude that if  $\omega^2/2\pi\rho > .2247$  the oblate spheroid is not a possible form of equilibrium, but if  $\omega^2/2\pi\rho < .2247$  there are two spheroidal forms possible, for there are two real values  $\lambda_1, \lambda_2$  of the abscissa corresponding to every value of the ordinate less than  $.2247$ .

**189. The ellipticity of the spheroidal forms.** When there are two real values  $\lambda_1, \lambda_2$  of  $\lambda$ , one is greater and the other less than 2.5293. Let  $\lambda_2$  be  $> \lambda_1$ , then as  $\omega^2/2\pi\rho$  is diminished we see from the graph that  $\lambda_1$  decreases and  $\lambda_2$  increases, and since  $\lambda_2 > 2.5293$  therefore  $\sqrt{1 + \lambda_2^2} > 2.72$ ; but the ratio of the semiaxes is  $\sqrt{1 + \lambda^2} : 1$ , so that the larger value of  $\lambda$  always represents a much flattened spheroid, and the smaller we take  $\omega^2/2\pi\rho$  the flatter does the spheroid become that corresponds to the root  $\lambda_2$ . On the other hand for small values of  $\omega^2/2\pi\rho$  the root  $\lambda_1$  will be small, and if  $\epsilon$  denote the ellipticity of the spheroid, we have

$$c(1 + \epsilon) = c\sqrt{1 + \lambda_1^2} \text{ so that } \epsilon = \frac{1}{2}\lambda_1^2 \text{ approximately,}$$

and therefore from ( $\gamma$ )

$$\omega^2/2\pi\rho = \sum_1^{\infty} (-)^{n-1} \frac{4n}{(2n+1)(2n+3)} \lambda_1^{2n} = \frac{8\epsilon}{15},$$

as far as the first power of  $\epsilon$ ; or

$$\epsilon = 15\omega^2/16\pi\rho \text{ approximately*}.$$

Maclaurin was the first to prove that an oblate spheroid is a possible form of equilibrium of a rotating mass of homogeneous fluid, and the spheroids are therefore commonly called **Maclaurin's Spheroids**.

**190. Application to the case of a fluid, the density of which is equal to the earth's mean density.**

Assuming for the moment that the earth is a sphere of radius  $r$  and mean density  $\rho$ , the attraction at the surface, which also measures the force of gravity ( $g$ ) at the pole, is  $\frac{4}{3}\pi\rho r$ . In C.G.S. units  $g = 980$  approximately and  $2\pi r = 4 \times 10^9$  cm.

Therefore in astronomical units

$$\rho = 3g/4\pi r = 367.5 \times 10^{-9}.$$

If we make  $\omega^2/2\pi\rho$  equal to its limiting value .2247 for the spheroidal form, and use the value just found for  $\rho$ , we obtain for the time of rotation  $2\pi/\omega = 2$  hrs. 25 mins. This is therefore the smallest time in which a homogeneous mass, of density equal to the earth's mean density, could rotate uniformly in the form of an oblate spheroid.

\* For a discussion in which the value of  $\omega^2/2\pi\rho$  is obtained correct to the third power of the ellipticity, see Darwin's *Scientific Papers*, Vol. III. p. 423.

Again, if we take for  $\omega$  the earth's angular velocity  $\frac{2\pi}{24 \times 60^2}$ , we obtain

$$\frac{\omega^2}{2\pi\rho} = \frac{2\pi \times 10^9}{24^2 \times 60^4 \times 367.5} = .0023 \text{ approximately,}$$

which is less than the critical value .2247, so that for this density and angular velocity two spheroidal forms are possible, there being two real values for  $\lambda$  as explained in Art. (188). The larger value corresponds to a very flat spheroid, and the smaller gives a spheroid whose ellipticity is by Art. (189)

$$\frac{15\omega^2}{16\pi\rho} = \frac{15}{8} \times .0023 = .0043 \text{ or } \frac{1}{232} \text{ nearly.}$$

The earth, as is known by geodetic measurements, differs very slightly in its form from a sphere, its ellipticity being  $\frac{1}{299.15}$ \*, that is the axes of the spheroid are in the ratio 300.15 : 299.15. The fact that the axes of the homogeneous fluid spheroid, of the same mean density as the earth and rotating in the same time, are, as we have just seen, in the ratio 233 : 232 shews that it is extremely unlikely that the earth was at any period of its history a homogeneous fluid mass.

**191. The prolate spheroid not a possible form.** It must be observed that we have not solved the general problem of the form of a mass of rotating fluid in relative equilibrium, but merely shewn that if  $\omega^2/2\pi\rho < .2247$  an oblate spheroid is a possible form. And we notice that this result is independent of the mass of the fluid and depends only on the density and angular velocity. If  $\omega^2/2\pi\rho > .2247$ , it does not follow that equilibrium is impossible but only that there is no oblate spheroidal form possible in this case.

To examine whether a prolate spheroid is a possible form we may write  $-\lambda'^2$  instead of  $\lambda^2$  in Art. (188), where  $\lambda'$  is to be  $< 1$ . Equations ( $\alpha$ ) and ( $\gamma$ ) of that Article then give

$$\frac{\omega^2}{2\pi\rho} = -\sum_1^{\infty} \frac{4n}{(2n+1)(2n+3)} \lambda'^{2n},$$

which is impossible because the opposite sides of the equation are of unlike signs. Hence a prolate spheroid is not a possible form of equilibrium.

\* See Encyc. Brit. Art. *Figure of the Earth*, by A. R. Clarke and F. R. Helmert.

192. An important distinction has been pointed out by Poisson (Tome II. p. 547) between the surfaces of equal pressure in a fluid at rest under the action of extraneous forces, and in a fluid at rest, or revolving uniformly about a fixed axis, under the action of the mutually attractive forces of its particles.

Let  $ABC$  be the free surface, and  $DEF$  any surface of equal pressure; then, in the former case, the resultant force at any point of  $DEF$  is perpendicular to the surface at that point, and is unaffected by the existence of the fluid between  $ABC$  and  $DEF$ ; this fluid could therefore be removed without affecting the equilibrium of the fluid mass bounded by  $DEF$ . In the latter case, the force at any point of  $DEF$ , although perpendicular to the surface at that point, is the resultant of the attractions of the mass of fluid contained by  $DEF$ , and of the mass contained between  $DEF$  and  $ABC$ ; these two components of the resultant force are not necessarily perpendicular to the surface, and the fluid external to  $DEF$  cannot in general be removed without affecting the equilibrium of the remainder.

If, however, the fluid be homogeneous, and the particles attract each other according to the Newtonian law, so that the free surface may be spheroidal, the surfaces of equal pressure will be similar spheroids; and in this case, since the resultant attraction of an ellipsoidal shell, bounded by two concentric, similar, and similarly situated ellipsoids, on an internal particle is zero, the portion of fluid between  $ABC$  and  $DEF$  may be removed, provided the rate of rotation remain unaltered.

Moreover we have shewn, Art. (188), that for a given value of  $\omega$  not exceeding a determined limit, there are two possible spheroidal forms: let  $ABC$ , the free surface, have one of these forms, and describe within the fluid mass a concentric spheroid,  $GHK$ , similar to the other spheroid; then the fluid between  $ABC$  and  $GHK$  may be removed without affecting the fluid mass  $GHK$ .

The action of the shell upon a particle at a point  $P$  of the surface  $GHK$  is not perpendicular to the surface at  $P$ , but this action, combined with the attraction of the mass  $GHK$ , and the hypothetical force measured by  $\omega^2 r$ , is perpendicular to the surface, at  $P$ , of the spheroid passing through  $P$ , which is concentric with, and similar to, the surface  $ABC$ .

In other words, the direction of sensible gravity, that is, of the

weight, of a particle on the surface is normal to the surface, and of a particle inside, normal to the surface of equal pressure which passes through the particle.

In the same manner if the free surface,  $ABC$ , have one of the possible forms, we can imagine a concentric shell of liquid added to the mass, and having its outer surface of the same form, or of the other possible form.

In the former case,  $ABC$  will still be a surface of equal pressure, but, in the latter case,  $ABC$  will cease to be a surface of equal pressure, since the new surfaces of equal pressure will be similar and similarly situated to the outer surface.

**193.** If a fluid mass be set in motion, about an axis through its centre of mass, with an angular velocity such as to make the value of  $\omega^2/2\pi\rho$  greater than the limit obtained in Art. (188), it does not follow that the fluid cannot be in equilibrium in the form of a spheroid, for it may be conceived that the mass will expand laterally with reference to the axis, taking a more flattened shape, until its angular velocity is so far diminished as to render the spheroidal form possible.

If the mass consist of perfect fluid, its form will oscillate through the spheroid of equilibrium, but if, as is the case in all known fluids, friction be called into play by the relative displacement of the particles, the oscillations will gradually diminish and at length a position of equilibrium will be attained. Employing the principle that the angular momentum of the system, relative to the axis, will remain constant, we can determine the final angular velocity, and the form ultimately assumed.

Considering the question generally, suppose the mass of fluid set in motion in any way, and then left to itself; the centre of mass will be either at rest or moving uniformly in a straight line, and all we have to consider is the motion relative to the centre of mass.

Draw through the centre of mass the plane, in the direction of which the angular momentum is a maximum; then, however during the subsequent motion the fluid particles act on each other, this plane, which may be called the 'momental' plane, will remain fixed, and when the motion of the particles relative to each other has been destroyed by their mutual friction, the axis perpendicular to this plane will be the axis of rotation of the fluid mass in its state of relative equilibrium.

Let  $H$  be the given angular momentum of the system, and  $\omega$  its ultimate angular velocity.

Taking  $c$  and  $c\sqrt{(1 + \lambda^2)}$  for the axes of the spheroid of equilibrium, and  $M$  for the mass, the expression for the angular momentum is  $\frac{2}{3}Mc^2(1 + \lambda^2)\omega$ ;

$$\therefore \frac{2}{3}Mc^2(1 + \lambda^2)\omega = H;$$

we have also

$$\frac{4}{3}\pi\rho c^3(1 + \lambda^2) = M,$$

and from these two equations, combined with the equation

$$\frac{\omega^2}{2\pi\rho} = \frac{(3 + \lambda^2)\tan^{-1}\lambda - 3\lambda}{\lambda^3} \dots \text{Art. (188)},$$

the values of  $c$ ,  $\omega$ , and  $\lambda$  can be determined.

From the first two we obtain

$$\frac{\omega^2}{2\pi\rho} = \frac{25H^2\left(\frac{4}{3}\pi\rho\right)^{\frac{1}{3}}}{6M^{\frac{1}{3}}}(1 + \lambda^2)^{-\frac{1}{2}};$$

$$\therefore \left\{ \frac{(3 + \lambda^2)\tan^{-1}\lambda - 3\lambda}{\lambda^3} \right\} (1 + \lambda^2)^{\frac{3}{2}} = \frac{25H^2}{6M^{\frac{1}{3}}}\left(\frac{4}{3}M\right)^{\frac{1}{3}}$$

is the equation which determines  $\lambda$ .

The equation always has a root, for the left-hand member vanishes and becomes infinite with  $\lambda$ , so that it ought to take a value equal to the positive constant on the right-hand side for some value of  $\lambda$  between zero and  $\infty$ . It can be shewn moreover that there is only one positive root, for the derivative of the left-hand member can be shewn to be positive always. Therefore regarding  $H$  and  $M$  as given quantities there is one spheroidal form and only one, towards which the oscillating fluid mass continually approximates.

This discussion may be found in Laplace's *Mécanique Céleste*, Tome II. p. 61; Pontécoulant's *Système du Monde*, Tome II. p. 409; and in Tisserand's *Mécanique Céleste*, Tome II. p. 96.

**194. Jacobi's Ellipsoid.** It was discovered by Jacobi that an ellipsoid with three unequal axes is a possible form of relative equilibrium for a mass of rotating liquid.

The following proof of Jacobi's theorem is taken from a paper by Liouville in the *Journal de l'École Polytechnique*, Tome XIV.

Taking the axis of rotation for the axis of  $z$ , suppose, if possible, that the surface of the liquid is of the form given by the equation

$$\frac{x^2}{1 + \lambda^2} + \frac{y^2}{1 + \lambda'^2} + z^2 = c^2 \dots\dots\dots(1).$$

Then, if  $M$  be the mass of the liquid, the resultant attractions on a particle at the point  $(x, y, z)$  of the surface are respectively  $Ax$ ,  $By$ , and  $Cz^*$ , where

$$A = \frac{3M}{c^3} \int_0^1 \frac{u^2 du}{(1 + \lambda^2 u^2) H},$$

$$B = \frac{3M}{c^3} \int_0^1 \frac{u^2 du}{(1 + \lambda'^2 u^2) H},$$

$$C = \frac{3M}{c^3} \int_0^1 \frac{u^2 du}{H},$$

$H$  representing the expression

$$\sqrt{(1 + \lambda^2 u^2)(1 + \lambda'^2 u^2)}.$$

The differential equation of the free surface is

$$(Ax - \omega^2 x) dx + (By - \omega^2 y) dy + Cz dz = 0,$$

and therefore, if the free surface be the ellipsoid (1),

$$(A - \omega^2)(1 + \lambda^2) = (B - \omega^2)(1 + \lambda'^2) = C \dots\dots\dots(2).$$

Eliminating  $\omega^2$ , we obtain

$$(1 + \lambda^2)(1 + \lambda'^2)(A - B) = C(\lambda'^2 - \lambda^2),$$

and, substituting for  $A$ ,  $B$ , and  $C$ , this reduces to

$$(1 + \lambda^2)(1 + \lambda'^2) \int_0^1 \frac{(\lambda'^2 - \lambda^2) u^4 du}{H^3} = (\lambda'^2 - \lambda^2) \int_0^1 \frac{u^2 du}{H}.$$

Rejecting the solution  $\lambda' = \lambda$ , which leads to the case of an oblate spheroid, and transposing, we obtain

$$\int_0^1 \frac{u^2 (1 - u^2)(1 - \lambda^2 \lambda'^2 u^2) du}{H^3} = 0 \dots\dots\dots(3),$$

an equation which, if  $\lambda$  be assigned, determines  $\lambda'$ .

Assigning a positive value to  $\lambda^2$ , the left-hand member of the equation is positive if  $\lambda' = 0$ , and is negative if  $\lambda' = \infty$ ; hence there is a positive value of  $\lambda'^2$  which will satisfy the equation.

Moreover, from the equations (2),

$$\begin{aligned} \omega^2 &= A - \frac{C}{1 + \lambda^2} \\ &= \frac{3M}{c^3} \int_0^1 \frac{\lambda^2 (1 - u^2) u^2 du}{(1 + \lambda^2)(1 + \lambda^2 u^2) H} \dots\dots\dots(4), \end{aligned}$$

and  $\omega^2$  is therefore a positive quantity.

\* See the *Mécanique Céleste*, Tome II.; Duhamel's *Cours de Mécanique*; or Minchin's *Statics*, Vol. II. p. 306.

Hence it is completely established that an ellipsoid with three unequal axes, the smallest of which coincides with the axis of rotation, is a possible form of the free surface.

From equation (3) it is clear that we must have  $\lambda^2\lambda'^2 > 1$ , otherwise the integrand would be positive throughout the whole range of integration and could not vanish. Hence either  $\lambda^2$  or  $\lambda'^2$  must be  $> 1$ , and therefore  $a/c$  or  $b/c$  must be greater than  $\sqrt{2}$ , so that the ellipticities of a Jacobian ellipsoid cannot both be small.

**195.** The resultant action of gravity at the surface is the resultant of the forces  $(A - \omega^2)x$ ,  $(B - \omega^2)y$ , and  $Cz$ , and is therefore inversely proportional to the perpendicular from the centre on the tangent plane.

Also, bearing in mind that the attractions of the liquid on an internal particle are  $Ax$ ,  $By$ , and  $Cz$ , and utilizing Leibnitz's theorem, it is easily shown that the resultant stress across any central plane section is perpendicular to that plane, and proportional to its area.

**196.** It was pointed out by Mr Todhunter, and demonstrated in the following manner, that the relative equilibrium of the rotating ellipsoid cannot subsist when the axis of rotation does not coincide with a principal axis.

Referred to the principal axes, let  $l, m, n$  be the direction cosines of the axis of rotation,  $M$  any point  $(x, y, z)$  of the mass, and  $N$  the foot of the perpendicular from  $M$  upon the axis.

$$\text{Then} \quad ON = lx + my + nz,$$

and, if  $ON = v$ , the co-ordinates of  $N$  are  $lv, mv, nv$ .

The acceleration  $\omega^2 MN$ , when resolved parallel to the axes, gives rise to the components

$$\omega^2(x - lv), \quad \omega^2(y - mv), \quad \omega^2(z - nv);$$

therefore the differential equation of the free surface is

$$\{\omega^2(x - lv) - Ax\}dx + \{\omega^2(y - mv) - By\}dy + \{\omega^2(z - nv) - Cz\}dz = 0;$$

hence the form of the free surface is given by the equation

$$\omega^2(x^2 + y^2 + z^2) - \omega^2(lx + my + nz)^2 - Ax^2 - By^2 - Cz^2 = \text{constant},$$

and this cannot represent an ellipsoid referred to its principal axes, unless two of the quantities  $l, m, n$  vanish.

Mr Greenhill remarks that a particle of the liquid at the end of

the axis of rotation will be at rest under the action of the attraction of the liquid alone, since the expression  $\omega^2 r$  vanishes at that point.

Hence the attraction on the particle must be normal to the surface, which is only the case at the end of an axis.

197. The following demonstration of Jacobi's theorem was given by Archibald Smith in the first volume (page 90) of the *Cambridge Mathematical Journal*, in 1838.

If a mass of liquid revolves, as if rigid, about the axis of  $z$  with the angular velocity  $\omega$ , and if  $X, Y, Z$  are the components of the attraction at the point  $(x, y, z)$ , the equation of the free surface is

$$(X - \omega^2 x) dx + (Y - \omega^2 y) dy + Z dz = 0.$$

Now, if the free surface is an ellipsoid,

$$X = Ax, \quad Y = By, \quad Z = Cz,$$

where  $A, B, C$  are independent of  $x, y, z$ .

Hence, if  $a, b, c$  are the semi-axes of the ellipsoid, we have it possible to identify the equations

$$(A - \omega^2) x dx + (B - \omega^2) y dy + C z dz = 0,$$

$$\frac{x}{a^2} dx + \frac{y}{b^2} dy + \frac{z}{c^2} dz = 0.$$

We must therefore satisfy the equations

$$A - \omega^2 = \frac{\lambda}{a^2}, \quad B - \omega^2 = \frac{\lambda}{b^2}, \quad C = \frac{\lambda}{c^2},$$

from which, by the elimination of  $\lambda$  and  $\omega^2$ , we obtain

$$a^2 b^2 (B - A) - (a^2 - b^2) c^2 C = 0 \dots\dots\dots(\alpha).$$

Now, if  $D = \{(a^2 + u)(b^2 + u)(c^2 + u)\}^{\frac{1}{2}}$ ,

and if  $M$  is the mass of the liquid,

$$A = \frac{3}{2} M \int_0^\infty \frac{du}{(a^2 + u) D}, \quad B = \frac{3}{2} M \int_0^\infty \frac{du}{(b^2 + u) D},$$

$$C = \frac{3}{2} M \int_0^\infty \frac{du}{(c^2 + u) D}.*$$

The equation ( $\alpha$ ) then becomes

$$(a^2 - b^2) \int_0^\infty \frac{du}{D} \left\{ \frac{a^2 b^2}{(a^2 + u)(b^2 + u)} - \frac{c^2}{c^2 + u} \right\} = 0.$$

\* See Kelvin and Tait's *Natural Philosophy*, Art. 494 n, or Minchin's *Statics*, Vol. II. p. 308.

If  $a$  is different from  $b$ , the relation between the axes must satisfy the equation

$$\int_0^\infty \frac{u du}{D^3} \left( \frac{1}{a^2} + \frac{1}{b^2} - \frac{1}{c^2} + \frac{u}{a^2 b^2} \right) = 0 \dots\dots\dots(\beta).$$

If  $a$  and  $b$  are given, this is an equation for determining  $c$ , and, since the left-hand member is negative when  $c = 0$ , and positive when  $c = \infty$ , there must be one real value of  $c$  which satisfies the equation.

Since  $u/D^3$  is positive, and since

$$\frac{1}{a^2} + \frac{1}{b^2} - \frac{1}{c^2} + \frac{u}{a^2 b^2}$$

is positive if  $u$  is large enough, it follows that, when  $u$  is small, this last expression must be negative.

Hence it appears that

$$\frac{1}{c^2} > \frac{1}{a^2} + \frac{1}{b^2},$$

and therefore that  $c$  is less than the least of the two quantities  $a$  and  $b$ .

To find the angular velocity, we have

$$\begin{aligned} \omega^2 (a^2 - b^2) &= Aa^2 - Bb^2 \\ &= \frac{3}{2} M (a^2 - b^2) \int_0^\infty \frac{u du}{(a^2 + u)(b^2 + u)} D, \end{aligned}$$

and therefore, if  $a$  is different from  $b$ ,

$$\omega^2 = \frac{3}{2} M \int_0^\infty \frac{u du}{(a^2 + u)(b^2 + u)} D \dots\dots\dots(\gamma),$$

and, this expression being a positive quantity, a possible value of  $\omega$  is obtained, and it is established that an ellipsoid with three unequal axes is a possible form of a mass of liquid rotating about the smallest axis.

198. That  $c$  must be the least axis may also be seen as follows :

$$\begin{aligned} \omega^2 &= \frac{a^2 A - c^2 C}{a^2} \\ &= \frac{3M}{2a^2} \int_0^\infty \left\{ \frac{a^2}{a^2 + u} - \frac{c^2}{c^2 + u} \right\} \frac{du}{D} \\ &= \frac{3M}{2a^2} (a^2 - c^2) \int_0^\infty \frac{u du}{(a^2 + u)(c^2 + u) D}, \end{aligned}$$

which shews that for  $\omega$  to be real, we must have  $c < a$ , and similarly  $c < b$ .

**199.** We notice that the forms given for  $A, B, C$  in Art. (197) can be reduced to those given in Art. (194) by writing  $c^2(1 + \lambda^2)$  for  $a^2, c^2(1 + \lambda^2)$  for  $b^2$  and  $c^2/u^2$  for  $c^2 + u$ , so that equations ( $\beta$ ), ( $\gamma$ ) of Art. (197) are the same as (3) and (4) of Art. (194). If the mass of the fluid  $M$  be given, we have also an equation  $\frac{4}{3}\pi\rho abc = M$ , and this equation together with ( $\beta$ ), ( $\gamma$ ) of Art. (197) may be regarded as determining  $a, b, c$  in terms of  $M, \rho$  and  $\omega$ .

These equations were investigated by C. O. Meyer\*, and a full discussion will also be found in Tisserand's *Traité de Mécanique Céleste*, Tome II. Chap. VII.†, shewing that the maximum value of  $\omega^2/2\pi\rho$  that will make a Jacobian ellipsoid a possible form of equilibrium is  $\cdot 18709$ , and that for this particular value the ellipsoid is one of rotation coinciding with one of Maclaurin's spheroids. It is further shewn that this value gives a unique maximum to the function on the right-hand side of equation ( $\gamma$ ) of Art. (197), and that for smaller values of  $\omega^2/2\pi\rho$  there is one and only one ellipsoid.

To summarize our results relating to Maclaurin's spheroids and Jacobi's ellipsoids, we have:

- if  $\omega^2/2\pi\rho > \cdot 2247$ , no spheroidal or ellipsoidal form,  
 if  $\cdot 2247 > \omega^2/2\pi\rho > \cdot 18709$ , two oblate spheroids,  
 and if  $\cdot 18709 > \omega^2/2\pi\rho$ , two oblate spheroids and one ellipsoid  
 with three unequal axes.

**200.** We have seen (Art. 194) that the ellipticities of a Jacobian ellipsoid cannot both be small, in fact that one of the axes is, in every case, at least  $\sqrt{2}$  times the axis of rotation. In a complete discussion of the Jacobian ellipsoids containing numerical tables and diagrams‡, Darwin remarks that the longer the ellipsoid the slower it rotates; that, while the angular velocity continually diminishes the moment of momentum continually increases, and that the long ellipsoids are very nearly ellipsoids of revolution about an axis perpendicular to that of rotation.

\* *Crelle's Journal*, Tome xxiv. (1842).

† For an abstract of the analysis see Appell, *Traité de Mécanique Rationnelle*, Tome III. p. 170.

‡ "On Jacobi's Figure of Equilibrium for a rotating mass of fluid." *Proc. Royal Soc.* Vol. xli. (1887), p. 319, or *Scientific Papers*, Vol. III. p. 119.

**201. Elliptic cylinder.** It can also be shewn that, theoretically, an elliptic cylinder is a possible form of the surface of an infinite mass of homogeneous gravitating liquid, rotating, as if rigid, about the axis of the cylinder.

If  $a$  and  $b$  are the semi-axes, the components of the attraction at the internal point  $x, y$  are

$$\frac{4\pi\rho bx}{a+b} \quad \text{and} \quad \frac{4\pi\rho ay}{a+b}$$

(Kelvin and Tait, Art. 494  $p$ ), and the equation of the free surface is therefore

$$\left(\frac{4\pi\rho b}{a+b} - \omega^2\right) x dx + \left(\frac{4\pi\rho a}{a+b} - \omega^2\right) y dy = 0.$$

Identifying this equation with

$$\frac{x dx}{a^2} + \frac{y dy}{b^2} = 0,$$

we find that

$$\omega^2 = 4\pi\rho ab/(a+b)^2.$$

This determines  $\omega$  when  $\rho, a, b$  are given; but if  $\omega, \rho$  are given we see that since

$$\frac{a-b}{a+b} = \sqrt{1 - \frac{\omega^2}{\pi\rho}}$$

an elliptic cylinder will not be a possible form of equilibrium unless  $\omega^2 < \pi\rho$ .

**202. Poincaré's Theorem.** We have seen that a Jacobian ellipsoid is an impossible form of relative equilibrium if

$$\omega^2/2\pi\rho > \cdot 18709,$$

an oblate spheroid is impossible if  $\omega^2/2\pi\rho > \cdot 2247$ , and an elliptic cylinder is not a possible form if  $\omega^2/2\pi\rho > \cdot 5$ ; Poincaré has proved that if  $\omega^2/2\pi\rho > 1$  there is no figure of equilibrium possible\*. For a necessary condition of equilibrium is that at every point of the free surface the resultant of the attraction and centrifugal force should be directed towards the interior, otherwise a part would be detached. Let  $V$  be the potential of the attracting forces and  $r$  the distance from the axis, and let

$$U = V + \frac{1}{2}\omega^2 r^2.$$

\* *Bulletin Astron.* Tome II. p. 117, or *Figures d'équilibre d'une masse fluide*, p. 11.

The resultant outward normal force is  $\frac{\partial U}{\partial n}$  and, for equilibrium, at every point of the free surface  $\frac{\partial U}{\partial n}$  must be negative. By Green's Theorem  $\iint \frac{\partial U}{\partial n} dS = \iiint \nabla^2 U dx dy dz$ , where the first integral is taken over the surface and the second throughout the volume of the fluid. And

$$\nabla^2 U = \nabla^2 V + 2\omega^2 = -4\pi\rho + 2\omega^2.$$

Therefore  $\iint \frac{\partial U}{\partial n} dS = 2(\omega^2 - 2\pi\rho) \times \text{volume}$ ,

and if  $\omega^2 > 2\pi\rho$ , the left-hand member is positive, which implies that at some points on the surface the resultant force is directed outwards and therefore equilibrium is impossible.

**203. Other equilibrium forms.** In addition to the forms that we have considered, the annulus was first considered by Laplace\* in connection with the theory of Saturn's rings, and has since been the subject of much investigation.

In the second edition of Kelvin and Tait's *Natural Philosophy*, § 778" a number of results relating to the stability of the forms already discussed were announced without proof. In attempting to establish these results, Poincaré was led to write a celebrated paper which appeared in the *Acta Mathematica*, 7, Stockholm, 1885. In this paper the problem of figures of equilibrium is discussed in a more general manner. It is shewn that possible figures of equilibrium form linear series, that is, series depending on a single parameter, such as the angular velocity, and such that to each value of the parameter corresponds either one and one only, or else a finite number of figures, and such that these figures vary in a continuous manner when the parameter is varied. Thus the Maclaurin's spheroids form a linear series, and Jacobi's ellipsoids form another. It may happen that the same figure belongs to two distinct linear series; such a figure is called a form of 'bifurcation.' Thus there is a particular member of the series of spheroids which at the same time belongs to the series of Jacobi's ellipsoids. Poincaré also considered, in this paper, the question of the stability of forms of equi-

\* *Mécanique Céleste*, Tome II. p. 155. See also Tisserand, *Mécanique Céleste*, Tome II. Chapters IX, X, XII, where the researches of Laplace, Clerk Maxwell, and Mme Kowalewski are discussed.

brium, and shewed that if a series of figures are stable up to a form of bifurcation then beyond that point the figures are unstable, the stable figures now belonging to the other series involved in the form of bifurcation. Thus Maclaurin's spheroid is stable only so long as its eccentricity is less than .8127, which is the point of bifurcation, and at this point Jacobi's ellipsoids become stable. In attempting to find points of bifurcation in the series of Jacobi's ellipsoids by the use of Lamé's functions, Poincaré found that there are an infinite number of series of figures of equilibrium. All the figures are symmetrical with regard to a plane perpendicular to the axis of rotation; they all have at least one plane of symmetry passing through the axis and some of them are figures of revolution. Among these figures only one is stable and it has only two planes of symmetry; it is the form that arises from the first bifurcation in the series of Jacobi's ellipsoids and has been called the pear-shaped figure of equilibrium, because of the resemblance to a pear of the figure sketched in Poincaré's paper\*. Further investigation however has shewn that the true form has less resemblance to a pear than was at first supposed; it has been discussed by Darwin in two papers†, and its form determined to a second approximation. At the point of bifurcation the axes of the Jacobian ellipsoid are as

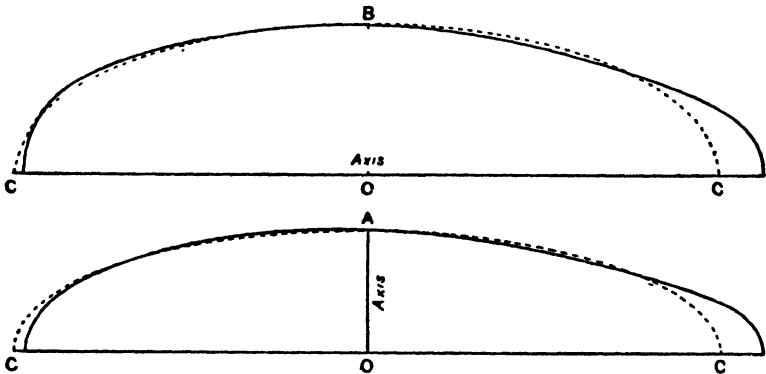

\* *Loc. cit.* p. 347, also *Figures d'équilibre d'une masse fluide*, p. 161.

† "On the pear-shaped figure of equilibrium of a rotating mass of liquid," *Phil. Trans.* Vol. 198 A (1901), p. 301, or *Scientific Papers*, Vol. III. p. 288, and "The stability of the pear-shaped figure of equilibrium of a rotating mass of liquid," *Phil. Trans.* Vol. 200 A (1902), p. 251, or *Scientific Papers*, Vol. III. p. 317. For a simple account of the stability of these figures see also an interesting paper by the same author on "The Genesis of Double Stars," being Chap. xxviii. in the volume *Darwin and Modern Science*.

65066 : 81498 : 188583, and  $\omega^2/2\pi\rho = \cdot 14200$ ; and the pear-shaped figure represents a small departure from this Jacobian ellipsoid, which takes the form of a protuberance at one end of its longest axis, and a blunting of the other end.

In the accompanying figures taken by permission from the second of Darwin's papers just referred to, the dotted line represents the Jacobian ellipsoid, and the other curve the pear-shaped figure; the upper is the equatorial section, and the lower is the meridional section in the plane of symmetry.

204. The following expressions for the attraction of a solid homogeneous ellipsoid of small ellipticities are often of use in discussing the forms assumed by masses of rotating liquid; viz. if  $a$ ,  $b$ ,  $c$ , the semi-axes, are such that  $b = a(1 - \epsilon)$  and  $c = a(1 - \eta)$ , then the component attractions at an internal point  $(x, y, z)$  are

$$A\rho x, \quad B\rho y, \quad C\rho z,$$

where

$$A = \frac{4}{3}\pi \left(1 - \frac{2}{5}\epsilon - \frac{2}{5}\eta\right),$$

$$B = \frac{4}{3}\pi \left(1 + \frac{4}{5}\epsilon - \frac{2}{5}\eta\right),$$

$$C = \frac{4}{3}\pi \left(1 - \frac{2}{5}\epsilon + \frac{4}{5}\eta\right)^*.$$

These expressions may also be written in the symmetrical form

$$A = \frac{4}{3}\pi \left(1 - \frac{2}{5} \frac{2a - b - c}{a}\right), \text{ etc.}$$

or as

$$A = \frac{4}{3}\pi \left(1 - \frac{6}{5} \frac{a - k}{k}\right), \text{ etc.}$$

where

$$k = \frac{1}{3}(a + b + c).$$

205. EXAMPLE. A mass  $m$  of homogeneous liquid and a distant sphere of mass  $M$  revolve in relative equilibrium about their centre of gravity with a small uniform angular velocity  $\omega$ ; shew that the free surface of the liquid is an ellipsoid of small ellipticities with its longest axis pointing to  $M$  and its smallest axis at right angles to the plane of motion, and that the ratio of the ellipticities of the principal sections passing through the line joining the centres of gravity of the bodies is  $4M + m : 3M$ . (Math. Tripos, 1888.)

If  $d$  is the distance between the bodies, the centre of gravity  $O$  of the mass  $m$  has an acceleration  $\frac{\mu M}{d^2}$ , and  $O$  may be reduced to rest if we apply this acceleration reversed to every element of the liquid mass.

\* See Routh's *Analytical Statics*, Vol. II. § 221 (2nd edition).

† Problems of this class were discussed by Laplace in the third book of the *Mécanique Céleste*.

If  $A$  is the centre of gravity of the mass  $M$ , and  $P$  any point in the liquid mass, the forces at  $P$  are  $\frac{\mu M}{PA^2}$  towards  $A$ ,  $\frac{\mu M}{AO^2}$  parallel to  $AO$ , the force due to the self-attraction of the liquid and the centrifugal force. Now  $\frac{\mu M}{PA^2}$  along  $PA$  is equivalent to  $\frac{\mu M}{PA^3} \cdot PO$  along  $PO$  and  $\frac{\mu M}{PA^3} \cdot OA$  parallel to  $OA$ .

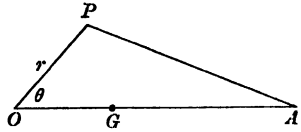

The former

$$= \frac{\mu M r}{\{d^2 + r^2 - 2dr \cos \theta\}^{\frac{3}{2}}} = \frac{\mu M r}{d^3}$$

to the first order of  $r/d$ .

The latter combined with  $\frac{\mu M}{A(\rho^2)}$

$$= \frac{\mu M d}{\{d^2 + r^2 - 2dr \cos \theta\}^{\frac{3}{2}}} - \frac{\mu M}{d^2} = \frac{\mu M}{d^2} \left\{ 1 + \frac{3r}{d} \cos \theta - 1 \right\} \\ = \frac{3\mu M r \cos \theta}{d^3}$$

parallel to  $OA$ .

If we assume an ellipsoidal form and take the axis of  $x$  along  $OA$ , and  $Oz$  for axis of rotation, we have

$$\frac{d\rho}{\rho} = \omega^2 (x dx + y dy) - A\rho x dx - B\rho y dy - C\rho z dz - \frac{\mu M r}{d^3} dr + \frac{3\mu M x}{d^3} dx.$$

And the free surface must be of the form

$$x^2 \left( \omega^2 - A\rho + \frac{3\mu M}{d^3} - \frac{\mu M}{d^3} \right) + y^2 \left( \omega^2 - B\rho - \frac{\mu M}{d^3} \right) - z^2 \left( C\rho + \frac{\mu M}{d^3} \right) = \text{const.} \\ \therefore a^2 \left( A\rho - \frac{2\mu M}{d^3} - \omega^2 \right) = b^2 \left( B\rho + \frac{\mu M}{d^3} - \omega^2 \right) = c^2 \left( C\rho + \frac{\mu M}{d^3} \right).$$

Now since the masses are rotating about their centre of gravity  $G$  with angular velocity  $\omega$ ,

$$\therefore \omega^2 \cdot OG = \frac{\mu \cdot M}{d^2},$$

but

$$(M+m) OG = Md;$$

$$\therefore \omega^2 = \frac{\mu(M+m)}{d^3};$$

$$\therefore a^2 A - b^2 B = \frac{\omega^2}{\rho} \left\{ a^2 \left( 1 + \frac{2M}{M+m} \right) - b^2 \left( 1 - \frac{M}{M+m} \right) \right\} \\ = \frac{\omega^2}{\rho} a^2 \frac{3M}{M+m},$$

since  $\omega^2/\rho$  and  $a-b$  are small.

$$\text{So also} \quad a^2 A - c^2 C = \frac{\omega^2}{\rho} \left\{ a^2 \left( 1 + \frac{2M}{M+m} \right) + c^2 \frac{M}{M+m} \right\} \\ = \frac{\omega^2}{\rho} a^2 \frac{4M+m}{M+m}$$

But from the last Article,

$$\begin{aligned} \alpha^2 A - b^2 B &= \frac{4}{3} \pi \left\{ (\alpha^2 - b^2) - \frac{6}{5} \alpha^2 \frac{(\alpha - k)}{k} + \frac{8}{3} b^2 \frac{(b - k)}{k} \right\} \\ &= \frac{4}{3} \pi (\alpha - b) \left\{ \alpha + b - \frac{6}{5} \left( \frac{\alpha^2 + \alpha b + b^2}{k} - \alpha - b \right) \right\}, \end{aligned}$$

and to get a result correct to the first order of the small difference  $\alpha - b$  we may put  $k = b = a$  in the last factor, so that

$$\alpha^2 A - b^2 B = \frac{1}{5} \pi \alpha (\alpha - b).$$

Similarly

$$\alpha^2 A - c^2 C = \frac{1}{5} \pi \alpha (\alpha - c).$$

Hence

$$\frac{\alpha - b}{\alpha - c} = \frac{\alpha^2 A - b^2 B}{\alpha^2 A - c^2 C} = \frac{3M}{4M + m}.$$

### EXAMPLES

1. A thin spherical shell of radius  $\alpha$  is just not filled with gravitating liquid of density  $\rho$ . If the liquid be rotating in relative equilibrium with angular velocity  $\omega$  about a diameter, prove that the tension in the shell across the great circle at right angles to the axis of rotation is at any point in that circle equal to  $\omega^2 \rho \alpha^3 / 8$ .

2. A rigid spherical shell is just filled with gravitating fluid consisting of a nucleus surrounded by a shell of lighter fluid. The whole is made to rotate about a diameter. Show that an oblate spheroid is a possible form for the surface of separation.

3. A rigid spherical shell contains two liquids which do not mix, and the whole system rotates as if rigid about an axis through the centre of the shell. Find the greatest angular velocity for which the common surface is spheroidal and does not touch the shell, and prove that, when the angular velocity does not exceed this value, the eccentricity of the spheroid is independent of the radius of the shell.

4. A mass of liquid of density  $\rho_1$  is surrounded by a mass of liquid of density  $\rho$  and the whole completely fills a case in the form of an oblate spheroid of small ellipticity  $\epsilon$ ; if the case rotates about its axis with small uniform angular velocity  $\omega$ , prove that a possible form of the common surface is an oblate spheroid of ellipticity  $\epsilon_1$  given by

$$15\omega^2/16\pi = \epsilon_1 \rho_1 + \frac{3}{2} (\epsilon_1 - \epsilon) \rho.$$

5. A case in the form of a *prolate* spheroid of small ellipticity  $\epsilon$  is filled by a fluid nucleus of density  $\rho + \sigma$  surrounded by a fluid of density  $\rho$ . Show that, if it rotates round its axis of figure with angular velocity  $\left( \frac{8}{5} \pi \rho \epsilon \right)^{\frac{1}{2}}$ , a possible form of the common surface is a sphere.

6. A mass of homogeneous liquid of density  $\rho$  completely fills a case in the form of the ellipsoid  $x^2/a^2 + y^2/b^2 + z^2/c^2 = 1$ , and rotates as a rigid body about the line  $x/l = y/m = z/n$  with uniform angular velocity  $\omega$ ; show that if  $\frac{1}{2} \lambda \rho$  is the greatest excess of the pressure at the centre over the pressure at a point on the surface,

$$\frac{l^2}{\frac{1}{A - \lambda/a^2} - \frac{1}{\omega^2}} + \frac{m^2}{\frac{1}{B - \lambda/b^2} - \frac{1}{\omega^2}} + \frac{n^2}{\frac{1}{C - \lambda/c^2} - \frac{1}{\omega^2}} = 0,$$

where  $Ax, By, Cz$  are the components of the attraction at an internal point.

7. A uniform sphere formed of ordinary attracting matter and of radius  $a$ , describes a circle with small uniform angular velocity  $\omega$  about a distant centre of force, which attracts inversely as the square of the distance. Prove that if the sphere is completely covered with water whose self-attraction can be neglected, the volume of the water must be greater than

$$10\pi\omega^2 a^3/3g,$$

where  $g$  is the value of gravity at the surface of the sphere.

8. Two gravitating liquids which do not mix, and whose densities are  $\rho$ ,  $\sigma$  ( $\rho > \sigma$ ), are enclosed in a rigid spherical envelope, and the whole rotates in relative equilibrium with a small uniform angular velocity  $\omega$  about a diameter of the sphere. Shew that a possible form of the common surface of the two liquids is an oblate spheroid of ellipticity  $\frac{1}{2}\omega^2/\pi(\rho + \frac{2}{3}\sigma)$ .

9. An infinite homogeneous cylinder of mean radius  $a$ , of small ellipticity  $\epsilon$  and density  $\rho$ , is surrounded by a mass of homogeneous liquid of density  $\sigma$ . The whole revolves about the axis in relative equilibrium under its own attraction with uniform angular velocity  $\omega$ . If  $a$  is the mean radius of the free surface, prove that a possible form of the free surface is an elliptic cylinder of small ellipticity

$$\pi a^4 (\rho - \sigma) \epsilon / \{2\pi(\rho - \sigma) a^2 + \pi\sigma a^2 - \omega^2 a^2\} a^2.$$

10. A given mass of gravitating fluid of density  $\rho$  can rotate in relative equilibrium with angular velocity  $\Omega$  with its free surface in the form of an ellipsoid with three unequal axes, the greatest semi-axis being  $a$ . A rigid vessel of this form is now made and the fluid in it is set rotating with the vessel in relative equilibrium with angular velocity  $\omega$  about the least axis. Prove that the pressure at any point of the surface is

$$\frac{1}{2}\rho(\omega^2 - \Omega^2)(x^2 + y^2) \text{ or } \frac{1}{2}\rho(\omega^2 - \Omega^2)(x^2 + y^2 - a^2),$$

according as  $\omega$  is greater or less than  $\Omega$ .

11. A solid sphere of mean density  $\rho$  is covered by a thin layer of liquid of uniform density  $\sigma$ . The whole rotates with small uniform angular velocity  $\omega$  about an axis through the centre of the sphere; the solid sphere attracts according to the law of the inverse square as if concentrated at a point on the axis at a small distance  $c$  from its centre, and the liquid also attracts according to the law of the inverse square. Shew that the outer surface of the liquid is approximately a spheroid of ellipticity  $15\omega^2/8\pi(5\rho - 3\sigma)$ , with its centre at a distance  $\rho c/(\rho - \sigma)$  from the centre of the sphere.

12. A solid gravitating sphere of radius  $a$  and density  $\rho$  is surrounded by a gravitating liquid of volume  $\frac{1}{2}\pi(b^3 - a^3)$  and density  $\sigma$ . The whole is made to rotate with small angular velocity  $\omega$ . Shew that the form of the free surface of the liquid is the spheroid of small ellipticity  $\epsilon$  given by

$$r = b(1 - \frac{2}{3}\epsilon P_2),$$

where

$$\epsilon = \frac{15\omega^2 b^3}{8\pi \{5(\rho - \sigma)a^3 + 2\sigma b^3\}},$$

and  $P_2$  is Legendre's coefficient of the second order.

13. A mass of homogeneous liquid, of density  $\rho$ , and volume  $\frac{1}{2}\pi(b^3 - a^3)$ , surrounding a fixed solid spherical core of radius  $a$  and density  $\sigma$ , is rotating as if solid with small angular velocity  $\omega$  about the polar axis, under its own attraction, that of the core, and the attraction of a particle of small mass  $M$  situated on the polar axis at a distance  $c$  from the centre of the sphere. Determine the form of the free surface, no portion of the sphere being un-

covered; and prove that the volume of liquid on the half of the sphere nearest to  $M$  is greater than if  $M$  were not present by

$$3M \sum_{n=0}^{n=\infty} (-1)^n \frac{\frac{1}{2}n}{n|n+1} \frac{(k/2c)^{2n+2}}{(\sigma-\rho) \frac{\alpha^3}{k^3} + \frac{4\rho n}{4n+3}}$$

Discuss the case when  $\rho$  is nearly equal to  $\sigma$ .

14. A homogeneous gravitating fluid just does not fill a rigid envelope in the form of an oblate ellipsoid. The fluid is rotating in relative equilibrium round the polar axis with kinetic energy  $E$ . If it rotates with kinetic energy  $E_1$  the envelope is a free surface of zero pressure. Prove that, for all values of  $E$  whether greater or less than  $E_1$ , the tension per unit length across the equatorial section of the envelope is

$$\frac{15}{32} E \sim E_1 \cdot A$$

where  $A$  is the area of a polar section of the ellipsoid.

15. A nearly spherical solid of mass  $M$ , the equation to whose surface is  $r = a(1 + \alpha P_4)$ , has a mass  $m$  of liquid on its surface, the solid and liquid attracting according to the Newtonian law, and the whole rotates about the axis of the harmonic with angular velocity  $\omega$ . Shew that the equator will be uncovered if  $m < 9aM/(12\lambda - 4) - 5\omega^2 a^3/(10\lambda - 6)$ , and that the poles will be uncovered if  $m < 6aM/(3\lambda - 1) + 5\omega^2 a^3/(5\lambda - 3)$ , where  $\lambda$  is the ratio of the density of the solid to that of the liquid.

16. Assuming the Earth to consist of a fluid surrounding a solid spherical nucleus, prove that the ellipticity, supposed small, is given by

$$\epsilon = m \frac{D/\rho}{\frac{1}{5} + 2(D/\rho - 1)},$$

where  $m$  is the ratio of the centrifugal force at the equator to the gravity there,  $D$  is the mean density of the whole Earth, and  $\rho$  the density of the fluid.

Deduce the cases of

- (1) a completely fluid Earth,  $\epsilon = \frac{7}{2}m$ ;
- (2) a very shallow sea on a solid nucleus,  $\epsilon = \frac{1}{2}m$ .

## MISCELLANEOUS EXAMPLES

1. A quantity of elastic fluid whose particles attract one another according to the law of nature fills a sphere in whose centre resides a central force  $\mu/\rho$ . The radius of the sphere is  $c$  and the mass of fluid  $(2\kappa - \mu)c$ , where  $\rho\kappa = \rho$ . Show that the conditions of equilibrium are satisfied if  $\rho$  varies inversely as  $r^2$ .

2. A sphere (radius  $c$ ) is just filled with water, and rotates about a vertical axis with angular velocity  $\omega$ , such that  $3c\omega^2 = 2g$ ; prove that the pressure in the surface of equal pressure which cuts the sphere at right angles is  $3g\rho c/4$ ,  $\rho$  being the density of water.

3. A mass of liquid is contained between three co-ordinate planes, each of which attracts with a force varying as the distance, and the absolute forces of attraction  $\mu, \mu', \mu''$  are in harmonic progression. Half an ellipsoid is fixed with its plane face against one of the co-ordinate planes, and its surface touching the other planes, its axes being parallel to the co-ordinate axes and inversely proportional to

$$\sqrt{\mu}, \sqrt{\mu'}, \sqrt{\mu''}.$$

If there be not sufficient fluid quite to cover the ellipsoid, the uncovered part will be bounded by a circle.

4. A mass of liquid is subject to the mutual gravitation of its particles, and to a repulsive force tending from a plane through its centre of gravity and varying as the perpendicular distance from that plane; shew that the conditions of equilibrium will be satisfied if the surface be a prolate spheroid of a certain ellipticity, provided the repulsive force be not too great.

5. A triangular area is immersed in a fluid with one side in the surface; the ellipse of largest possible area is inscribed in it; shew that the depth of the centre of pressure of the remainder of the triangle is  $\frac{18\sqrt{3} - 5\pi}{36\sqrt{3} - 12\pi}$  of the depth of its lowest point.

6. Fluid self-attracting, according to Newton's law, just fills a vessel in the form of the ellipsoid  $\frac{x^2}{a^2} + \frac{y^2}{b^2} + \frac{z^2}{c^2} = 1$ ; find the pressure at any point, and the points of maximum and minimum pressure on the vessel.

7. If  $a, \beta, \gamma, \delta$  be the depths of the corners of a quadrilateral area which is wholly immersed in liquid, and  $h$  the depth of its centre of gravity, the depth of its centre of pressure is

$$\frac{1}{2}(a + \beta + \gamma + \delta) - \frac{1}{6h}(\beta\gamma + \gamma\alpha + \alpha\delta + \beta\delta + \gamma\delta).$$

8. A conical vessel of height  $h$ , vertex downwards, is filled with liquid the density of which is  $\lambda x$ ,  $x$  being the depth. This is poured into another vessel in the form of a surface of revolution, and it is found that the new density is  $\mu x^2$ . Prove that the form of the vessel is given by the equation

$$y^2 + z^2 = \frac{2\mu}{\lambda} x \left( h - \frac{\mu}{\lambda} x^2 \right)^2 \tan^2 a.$$

9. An embankment of triangular section  $ABC$  supports the pressure of water on the side  $BC$ : find the condition of its not being overturned about the angle  $A$  when the water reaches to  $B$ , the vertex of the triangle: and shew

that, when the area of the triangle is reduced to the minimum consistent with stability for a given depth of water,

$$\tan C = \frac{\sqrt{s^2 + 2s + 9}}{3 - s},$$

$$\tan A = \frac{\sqrt{s^2 + 2s + 9}}{s - 1},$$

where  $s$  is the specific gravity of the embankment.

10. A mass of fluid is in equilibrium under the action of its own attraction : prove that the pressure at any point  $(x, y, z)$  is given by the equation

$$\frac{\partial}{\partial x} \left( \frac{1}{\rho} \frac{\partial p}{\partial x} \right) + \frac{\partial}{\partial y} \left( \frac{1}{\rho} \frac{\partial p}{\partial y} \right) + \frac{\partial}{\partial z} \left( \frac{1}{\rho} \frac{\partial p}{\partial z} \right) = -4\pi\rho,$$

where  $\rho$  is the density at  $(x, y, z)$ .

An infinite mass of fluid such that  $p = k\rho^2$ , where  $k$  is a constant, surrounds a rigid spherical shell and is in equilibrium under its own attraction, the pressure at infinity being  $\Pi$  : find the pressure at any point.

11. A bridge of boats supports a plane rigid roadway  $AB$  in a horizontal position. When a small moveable load is placed at  $G$  the bridge is depressed uniformly ; when the load is placed at a point  $C$  the end  $A$  is unaltered in level ; when at  $D$  the end  $B$  is unaltered in level ; and when at  $P$  the point  $Q$  of the roadway is unaltered in level.

Prove that  $AG \cdot GC = BG \cdot GD = PG \cdot GQ$ ; and that the deflexion produced at a point  $R$  by a load at  $P$  is equal to the deflexion produced at  $P$  by the same load at  $R$ .

12. A cup floats upright in oil, and is ballasted with water ; find its form and sketch it, when the difference of level of the two liquid surfaces is the same for all degrees of immersion.

13. If a liquid be inclosed in a vessel of any form and be allowed to run into another vessel of different form, and if  $p$  be the pressure at  $x, y, z$ , in either of the vessels referred to rectangular co-ordinates independent of them, the difference between the two values of  $\iiint p \, dx \, dy \, dz$  differs from the work done by the liquid in running from the upper to the lower vessel by the work required to bring the surface of the fluid in the lower vessel to the same horizontal plane with the original surface in the upper.

14. A vessel in the shape of a paraboloid of revolution contains some fluid which is rotating about the vertical axis of the paraboloid. Find the angular velocity when the fluid begins to spill, and shew that, if this is  $\sqrt{g/l}$ , the vessel must have been half full of fluid.

If the paraboloid be not of revolution but of the form  $z = \frac{x^2}{l} + \frac{y^2}{l'}$ , the axis of  $z$  being vertical, and if  $z_1, z_2$  be the greatest and least heights of the curve in which the surface of the fluid meets the vessel, prove that

$$\frac{1}{z_2} - \frac{1}{z_1} = \frac{\omega^2}{2gc} (l \sim l'),$$

where  $c$  is the distance between the vertices of the two paraboloids.

15. A cylindrical diving-bell is suspended with its axis vertical at a depth such that the water rises half-way up the bell : find the least distance of the centre of gravity of the bell from the centre of its upper surface, consistent with the condition that the equilibrium may be stable with reference to an angular displacement of the axis.

16. Incompressible fluid is at rest under the action of forces

$$-\frac{\mu x}{a^2}, \quad -\frac{\mu y}{b^2}, \quad -\frac{\mu z}{c^2},$$

respectively parallel to the axes, and a particle, the density of which is less than that of the fluid, is placed anywhere in the surface

$$\frac{x^2}{a^2} + \frac{y^2}{b^2} + \frac{z^2}{c^2} = m;$$

prove that, neglecting the resistance, the velocity of the particle when crossing the surface defined by the quantity  $m'$  varies as

$$\sqrt{m' - m}.$$

17. An elastic spherical envelope is in equilibrium when it contains air at twice the atmospheric density, and its radius is twice the natural size; if the barometer fall  $1/n^{\text{th}}$  of an inch, find the time of a small oscillation in the magnitude of the envelope.

18. A right cone rests in a vessel containing equal depths of two given fluids, with its vertex fastened to the bottom and its axis vertical. Find the condition for stable equilibrium.

19. A straight uniform rod consisting of matter attracting as  $(\text{dist.})^{-1}$  is surrounded by fluid at rest subject to its attraction only; shew that the differential equation to the meridian sections of the surfaces of equal pressure can be put in the form

$$\frac{dy}{dx} \cdot \psi + \log \frac{r}{r'} = 0,$$

$r, r'$  being the distances of the point  $(x, y)$  from the ends of the rod, and  $\psi$  the angle subtended by the rod at that point.

20. A portion of a paraboloid, latus rectum  $4a$ , is cut off by a plane perpendicular to the axis at a distance  $3a$  from the vertex; if the vertex of the paraboloid be fixed at a depth  $\frac{\sqrt{3}}{2}a$  beneath the surface of a liquid, shew that it will rest with the focus in the surface if the ratio of the density of the liquid to that of the solid be 729 : 232.

21. A mass ( $M$ ) of fluid, in which the density at any point is the sum of a given constant quantity and a quantity bearing a given constant ratio to the pressure at that point, revolves about a fixed axis with a given constant angular velocity, and is attracted to a point in that axis by a given force which varies as the distance: find the form of the free surface; and shew that its least semi-diameter ( $b$ ) is determined by the equation

$$M = m \int_0^b e^{\frac{b^2 - x^2}{c^2}} x^2 dx,$$

where  $m$  and  $c$  are given constants.

22. A centre of force, repelling inversely as the square of the distance, lies below the surface of a homogeneous inelastic fluid, which is also acted on by gravity and is at rest: the intensity of the force, at a point in the surface of the fluid vertically above its centre, is equal to that of gravity: prove that the external surface of the fluid has a horizontal asymptotic plane, and that the centre of force is environed by an internal cavity, the summit of which is at the external surface of the fluid.

Find the volume of the cavity in terms of its length.

23. A right prism on a square base has another prism, also on a square base, attached to it, so that their axes are coincident and sides parallel, and the whole floats on a fluid with their common plane in the plane of flotation. If the sides of the bases of the two prisms are in the ratio 2 : 1, find their limiting heights in order that the equilibrium may be stable.

24. A heavy cube is moveable about an axis, which passes through, and bisects, the opposite sides of one face; this axis being fixed horizontally within an empty vessel, so that the cube is suspended in the position of equilibrium, find the depth to which fluid must be poured in, so as to render the equilibrium unstable, and the greatest ratio of the densities of the cube and fluid, that this may be possible.

Supposing the cube half immersed and the equilibrium stable, find the time of a small oscillation.

25. A cylinder whose axis is vortical is floating in a fluid in which the density at any point varies as the  $n^{\text{th}}$  power of the depth; the cylinder is depressed till its upper end just coincides with the surface of the fluid, and on being let go it rises just out of the fluid; shew that, when the cylinder was floating, the depth immersed was to the height of the cylinder as 1 to  $(n+2)^{\frac{1}{n+1}}$ .

26. The height and latus rectum of a uniform paraboloid of revolution are  $h$  and  $l$ , and its specific gravity with respect to a fluid in which it is floating is  $s$ ; shew that there will certainly be only one position of equilibrium with the vertex immersed if

$$2h(2 - 3s^{\frac{1}{2}}) < 3l.$$

27. If a vessel of thin material, in the shape of a paraboloid of revolution, contain liquid, shew that the equilibrium will be always stable, provided the density of the fluid inside be greater than that without; the weight of the vessel being neglected.

28. A frustum of a cone floats with its axis vertical in a liquid of twice its own density. Prove that the equilibrium will be stable if

$$h^2 < \frac{(a-b)^2}{m-1}, \text{ where } m = \frac{2^{\frac{1}{2}}(a^4+b^4)}{(a^3+b^3)^{\frac{2}{3}}},$$

$h$  being the height of the frustum, and  $a, b$  the radii of its ends.

Also if it float with its axis horizontal the equilibrium will be stable if

$$h^2 > \frac{3(a+b)^2(a^2+b^2)}{a^2+4ab+b^2}.$$

29. A vessel in the form of a cube of side  $12a$  containing liquid is placed so as to rest on the top of a perfectly rough fixed sphere of radius  $5a$ ; neglecting the weight of the vessel, prove that for displacements in planes parallel to the vertical faces there will be stability provided the depth of the liquid is between  $4a$  and  $6a$ .

30. An isosceles triangular lamina, of which the sides  $AB, AC$  are equal, floats with the angular point downwards in a liquid of which the density varies as the depth: if  $AD$  be perpendicular to  $BC$ , prove that if the lamina can float with the line  $AD$  inclined at an angle  $\theta$  to the vertical,  $\theta$  is given by the equation

$$81\sigma \sin^3 \theta = 64\rho \cos^3 a (\sin^2 \theta - \sin^2 a)^2,$$

where  $2a$  is the angle  $BAC$ ,  $\sigma$  is the density of the lamina, and  $\rho$  is the density of the liquid at a depth equal to  $AB$  or  $AC$ .

31. A solid of revolution floats with its axis vertical, and is sunk to different depths by placing weights at a fixed point of its axis. Find the form when the equilibrium is always neutral.

32. If a body float at rest, shew that for any displacement, consistent with the condition that the weight of the fluid displaced be equal to that of the float, the difference of the distances of the centres of gravity of the float and of the fluid displaced below the surface of the fluid will, in general, be a maximum or minimum according as the equilibrium is unstable or stable.

Moreover if  $Z$  be this difference, and the body be symmetrical with respect to a vertical plane, perpendicular to the line about which the displacement aforesaid is made, and  $\theta$  be the inclination of any fixed line in the body and in that plane to the vertical, the time of a small oscillation will be that of a simple pendulum of which the length is  $\frac{k^2}{d^2 Z}$ , where  $k$  is the radius of gyration

$$d\theta^2$$

about a line through the centre of gravity parallel to the axis of displacement.

Mention any conditions which limit the generality of these theorems.

33. An ellipsoid floats with the least axis ( $2c$ ) vertical in a fluid of twice its density, and makes small oscillations in a vertical plane about a point in the major axis ( $2a$ ) which is fixed. Shew that the period is

$$2\pi \sqrt{\frac{8}{15} \frac{c}{g} \frac{5\kappa^2 + a^2 + c^2}{4\kappa^2 + a^2 - c^2}}$$

where  $\kappa$  is the central distance of the fixed point.

34. A pneumatic railway carriage can move freely without friction in a tunnel which it exactly fits. It is placed at rest at one end, and an engine begins to exhaust the air at the other, pumping out equal volumes in equal times. Shew that at time  $t$  the distance of the carriage from the end to which it is travelling is determined by an equation of the form

$$x \frac{d^2x}{dt^2} + b \frac{dx}{dt} + n(x+bt) = nat.$$

35. A solid of revolution possesses this property. A portion being cut off by a plane perpendicular to its axis and immersed vertex downwards in a liquid and then displaced through a small angle, the moment tending to restore equilibrium is independent of the amount cut off. Shew that, if  $y=f(x)$  be the generating curve, to determine  $f$  we have

$$[f(x)]^2 = \rho [1 + \{f'(x)\}^2 + f(x)f''(x)] [f\{x + f(x)f'(x)\}]^2,$$

$\rho$  being the density of the solid compared with the fluid.

36. From a solid hemisphere, of radius  $r$ , a portion in the shape of a right cylinder, of height  $h$ , coaxial with the hemisphere and having the centre of its base at the centre of the hemisphere, is removed. Into this portion is fitted a thin tube which exactly fits it. The solid is placed with its vertex downwards in a fluid, and a fluid, of density  $\rho$ , is poured into the tube. Find how much must be poured in, in order that the equilibrium may be neutral; and if the tube be filled to a height  $2h$ , shew that

$$\frac{\rho}{s} = \frac{r^4 - 2b^2h^2}{b^4},$$

$s$  being the density of the solid.

37. A solid body is floating in a liquid of variable density and its position is slightly changed so that the mass of liquid displaced remains unaltered. If  $f(z)$  be the density at a depth  $z$ , and  $(x, y, z)$  the co-ordinates of any point in the immersed surface of the body, referred to the surface as the plane  $xy$ , prove

that the point in the plane of flotation about which the body turns is the centre of gravity of that plane treated as a lamina, the density of which at the point  $(x, y)$  is  $f(z)$ .

38. A cup whose outside surface is a paraboloid of revolution of latus rectum  $l$ , and whose thickness measured horizontally is the same at every point and very small compared with  $l$ , has a circular rim at a height  $h$  above the vertex, and rests on the highest point of a sphere of radius  $r$ . If water be now poured in until its surface cuts the axis of the cup at a distance  $\frac{3}{2}h$  from the vertex, and if the weight of water be four times that of the cup, shew that the equilibrium will be stable, if

$$\frac{h}{l} < \frac{r-2l}{2r+l}.$$

39. An isosceles triangular lamina  $ACB$  is at rest with its plane vertical, and its vertex  $C$  fixed at a depth  $c$  below the surface of a liquid, the density of which varies as the depth. If the density of the lamina be the same as that of the liquid at the depth  $d$ , and if  $\theta$  be the angle which the altitude  $h$  of the triangle makes with the vertical, prove that

$$8dk^3 \cos^2(\theta + a) \cos^2(\theta - a) = 3c^2 \cos^2 a \cos \theta,$$

the angle  $ACB$  being  $2a$ .

40. A hollow cylinder of height  $2h$  and radius  $c$  with both ends closed contains water, and is placed with the centre of its base in contact with the highest point of a rough sphere of radius  $r$ ; the weight of the water is equal to that of the cylinder; shew that the equilibrium will be stable if the water occupy a length of the cylinder which lies between the roots of

$$2x^2 - 4(2r - h)x + c^2 = 0.$$

41. A weightless shell in the form of a paraboloid of revolution rests in a similar shell, the parameter of which is double that of the former, and contains fluid whose density varies as (depth) <sup>$n$</sup> . Find the depth of the fluid in order that the equilibrium may be neutral.

42. If when the barometer stands at 30 inches, the specific gravity of mercury being 13.596 referred to water, of which a cubic inch weighs 252.77 grains, a cubic yard of atmospheric air is compressed into a vessel containing a cubic foot, find approximately the numerical measure of the energy stored up therein.

43. The expansions of water and glass are given by the formula

$$V_t = V_4 \{1 + a(t-4)^2\}, \text{ and } V_t = V_0(1 + 5at),$$

where  $t$  is the temperature centigrade. If a water thermometer be constructed and graduated in the same way as the common mercurial thermometer, prove that except at the freezing and boiling points it will always give too low a reading; that that reading will be negative from  $0^\circ$  to a little over  $13^\circ$ ; and that the error will be a maximum when  $5at^2 + 2t = 100$ .

44. A quantity of air, whose density is  $\rho$  and pressure  $p$ , is enclosed in a spherical vessel. Shew that if a centre of force  $\mu D^m$  be placed at the centre of the sphere the density at a distance  $r$  from the centre will be

$$\frac{n+1}{3} \frac{\alpha^2}{\Gamma(n+1)} \left\{ \frac{\mu \rho}{p(n+1)} \right\}^{\frac{3}{n+1}} e^{-\frac{\mu \rho}{p(n+1)} r^{m+1}},$$

the intensity of the force being supposed so great that the density of the air in contact with the vessel may be neglected.

45. The pressure and density of the atmosphere at the earth's surface being  $p_0, \rho_0$  and the temperature at higher points varying inversely as the  $n$ th power of the distance from the centre of the earth, prove that the pressure  $p$  at a distance  $r$  from the earth's centre is such that

$$\log \frac{p}{p_0} = g\rho_0 \frac{(a^{n-1} - r^{n-1})}{(n-1)p_0 a^{n-2}},$$

where  $a$  is the radius of the earth.

If  $n=1$ , shew that a spherical balloon of material equally extensible in all directions will have its volume greatest when  $r$  is given by the equation

$$p_0(m-1) \frac{a^m}{r^m} = \frac{2\lambda}{c} \left\{ 1 - m^{\frac{1}{3}} \frac{a^{\frac{m-1}{3}}}{r^{\frac{m-1}{3}}} \right\},$$

where  $m = \frac{g\rho_0 a}{p_0}$ ,  $\lambda$  is the modulus of elasticity, and  $c$  is the unstretched radius of the balloon, it being just filled and unstretched when it leaves the ground.

46. A balloon is at a certain moment at a height  $h$ , descending with velocity  $V$ , and moving horizontally with a velocity  $V'$  equal to the velocity of the wind at that height. If the velocity of the wind be proportional to the height, and if with a view to descending at a particular spot the escape of the gas be regulated so as to keep the velocity of descent constant, prove that a miscalculation  $dh$  in the initial height will produce in the point reached an error

$$\frac{V' dh}{c^2 V} \left\{ 1 + \frac{1}{2} c^2 - e^{-c} (1+c) \right\}, \text{ where } c = \frac{gh}{V^2}.$$

47. Prove that the work done during the  $(n+1)$ th stroke of a Smeaton's air pump, supposing the expansion to be isothermal, is equal to

$$\Pi \left( \frac{A}{A+B} \right)^n \left\{ (nB+A) \log \left( 1 + \frac{B}{A} \right) + B \right\},$$

$A$  being the volume of the receiver and  $B$  that of the barrel.

48. The condensation being isothermal, find the work done during the  $n$ th stroke of a condenser.

49. Prove that if a receiver of volume  $A$  is charged with air by a condensing pump of capacity  $B$  so rapidly that the loss of heat by conduction may be neglected, the pressure of air in the receiver after  $n$  strokes will be  $(1+nB/A)^n$  times the pressure of the atmosphere; and determine the temperature in the receiver and the work done in compressing the air.

Determine also the pressure of the air in the receiver after thermal equilibrium by conduction is re-established.

50. A solid spherical nucleus of given mass and radius is surrounded by a gravitating atmosphere of elastic fluid ( $p = \kappa\rho$ ). Prove that the equation determining the pressure is

$$\frac{d}{dr} \left( r^2 \frac{dp}{p dr} \right) + \frac{4\pi}{\kappa^2} r^2 \rho = 0.$$

Find the conditions that the pressure may be of the form  $\frac{A}{r^a}$ .

51. Assuming that the surfaces of equal density in the interior of the earth are concentric spheres, and that the pressure is connected with the density by the formula  $p = \frac{k}{2} (\rho^2 - \rho_a^2)$ , where  $\rho_a$  is the density at the surface, prove that

$$\rho = \rho_a \frac{a \sin \sqrt{4\pi r^2/k}}{r \sin \sqrt{4\pi a^2/k}},$$

where  $a$  is the radius of the earth, and  $r$  the distance of the point under consideration from the centre. The gravitational unit of mass is here used, and the effect produced by the earth's rotation is neglected.

52. A solid is composed of two cubes, symmetrically joined together, but of different material and size. It floats with the common plane in the surface of a fluid. Find the condition of stability.

53. A solid in the form of a paraboloid of revolution floats with its axis vertical; if the centre of gravity coincide with the metacentre, prove that the equilibrium is stable.

54. A solid in the form of a paraboloid of revolution floats with its axis vertical in a liquid, the density of which is  $n$  times that of the paraboloid. If the height  $h$  of the paraboloid is such that its centre of gravity is above the metacentre at the height  $c$ , prove that there is a position of equilibrium in which the axis is not vertical, and the base is entirely out of the liquid, if  $c < h(1 - n^{-\frac{1}{2}})^2$ .

55. A ship of mass  $M$  has its sides in the neighbourhood of the water's edge vertical: the depth of the centre of gravity of the water displaced is  $\bar{z}$ . A small extra load  $\theta M$  is placed symmetrically on the ship, which sinks through a distance  $Z$ ; and  $\bar{z}$  becomes  $\bar{z} + \delta z$ . Prove that, retaining the squares of small quantities,

$$\delta \bar{z} = Z - \theta \bar{z} + \theta^2 \bar{z} - \frac{1}{2} \theta Z.$$

56. A homogeneous ellipsoid floats in a liquid with its least axis  $COO'$  vertical, and a weight  $w$ ,  $\frac{1}{3}$  of that of the ellipsoid, fixed at the upper end  $C$ , such that the plane of flotation passes through the centre. Prove that, if it be turned about the mean axis ( $b$ ) through a finite angle  $\theta$ , the moment of the couple which will keep it in that position will be

$$w \left\{ c - ae^2 \cos \theta (1 - e^2 \cos^2 \theta) - \frac{1}{2} \right\} \sin \theta,$$

where  $e$  is the eccentricity of the section ( $a, c$ ).

57. A mass of  $m$  tons placed amidships at the distance  $c$  from the medial line on the deck of a vessel, whose total displacement is  $\mu$  tons, is observed to heel it over through a small angle  $\theta$ ; shew that for the unloaded ship the height of the metacentre above the centre of gravity is approximately equal to  $mc/\mu\theta$ ; and that this expression may be made correct to the second order by adding to it

$$\frac{m}{\mu} \left( b - \frac{1}{A} \frac{dI}{dh} \right),$$

where  $b$  is the height of the centre of gravity of  $m$  above the water line,  $h$  is the depth of the keel, and  $A$  and  $I$  are the area and moment of inertia of the section at the water line, supposed to be approximately known. (*Tripes*, 1836.)

58. A small spherical cavity (radius =  $R$ ) in an attracting mass is filled with homogeneous incompressible fluid, and the attraction at the centre of the sphere is evanescent: prove that the fluid pressure at the centre cannot be less than  $-\frac{1}{2} \rho c R^2$ , and the total pressure on the surface of the cavity not less than  $-(c + \frac{2}{3} \pi \rho) 2\pi \rho R^4$ , where  $\rho$  is the density of the fluid, and,  $U$  denoting the potential of the attracting mass,  $c$  is the least algebraical value of  $\frac{d^2 U}{ds^2}$  at the centre for an element  $ds$  drawn in any direction from the centre.

59. A cylindrical water-tank is free to swing on a horizontal axis which is a diameter of one of its cross sections, situated below the middle of its height. Shew that it will hold less water before it tips over, if the surface of the water

is free than if it is held by a lid fixed to the tank. If in the former case the water may rise to a height  $H$  above the axis of free rotation, shew that in the latter it may rise an additional height  $(H^2 + 2k^2)^{\frac{1}{2}} - H$ , where the moment of inertia of the cross section, of area  $A$ , with respect to the axis of rotation, is  $Ak^2$ .

60. Two spherical closed balloons of equal weight and radius  $a$ , one made of inextensible material, the other of extensible material whose modulus of elasticity is  $E$ , are filled with equal amounts of the same kind of gas at atmospheric pressure  $\Pi$ . They are supported at the same height at the ends of a light string which passes over a smooth pulley. If the string be cut, shew that the difference of the heights of the balloons when in equilibrium will be  $\frac{3\Pi}{g\rho} \log \frac{r}{a}$ , where  $r$  is the real root of the equation  $r^3 - ar^2 - \frac{3\Pi T a}{8\pi g\rho E} = 0$ ,  $T$  is the tension of the string, and  $\rho$  the density of air at pressure  $\Pi$ , the temperature being supposed constant.

61. An elastic unstretched circular membrane is attached by its circumference to a rigid ring, and, being acted upon on one side by fluid pressure, takes up the form of a surface of revolution. It is found that any small square traced on the unstretched membrane with one side along a radius is distorted into a rectangle with its sides in a constant ratio; prove that the new form of the membrane must be a cone, and find the law of the fluid pressure upon it.

62. Given that the surface tension  $T$  of water is 81 dynes per centimetre at  $20^\circ \text{C}$ ., and that  $dT/dt = -T/550$ , investigate the coefficient of expansion of a soap-bubble as the temperature  $t$  rises.

63. A drop of viscous fluid rotates uniformly about an axis through its centre, and is under the action of no forces beyond its surface tension. Assuming that the form is that of a surface of revolution, and measuring  $y$  from its centre along the axis of revolution, prove that the meridian curve is given by the equation

$$\frac{dy}{dx} = \frac{x(x^2 + c^2)}{\sqrt{a^2(a^2 + c^2)^2 - x^2(x^2 + c^2)^2}},$$

where  $a$  is the equatorial radius.

64. A tube in the form of a right circular cylinder of natural radius  $a$  is made of a perfectly flexible material, which is inextensible along the generating lines but elastic along the generating circles. Two discs just fitting the tube are firmly fastened to it at its ends and then gas of a given pressure is forced in, the discs being free to approach each other; prove that the differential equation of the meridian section is

$$y^2 \frac{d^2y}{ds^2} + 2y \left( \frac{dx}{ds} \right)^2 = m(y - a) \left( \frac{dx}{ds} \right)^3,$$

where  $m$  is a function of the elasticity and pressure.

For all pressures the principal radii of curvature of the tube at the discs are in the ratio of 2 to 1.

For different initial lengths of the tube, the maximum curvature of the meridian section at the broadest point is  $\frac{m}{a} \left( \frac{1}{2} - \frac{1}{m} \right)^2$ , the other principal curvature being

$$\frac{1}{a} \left( \frac{1}{2} - \frac{1}{m} \right).$$

65. A spherical soap-bubble of mass  $m$  contains air which obeys Boyle's Law: and the tension ( $t$ ) of the film does not vary for small changes of radius. The film is performing small oscillations about its position of equilibrium. If the film be not distorted from the spherical form, shew that the time of an

oscillation is  $\sqrt{\frac{\pi m}{4t}}$ ; where the inertia of the air is neglected and the bubble has been placed in a vacuum.

66. A closed surface is formed by the revolution of a catenary of parameter  $c$  round a chord parallel to the directrix and distant  $k$  from it. If it be filled with liquid of density  $\sigma$  which rotates round the axis with uniform angular velocity  $\omega$ , and be immersed in the same liquid, a small aperture at one of the angular points allowing communication between the exterior and interior liquid, prove that the principal tensions at the distance  $r$  from the axis will be

$$\sigma\omega^2r^3(k-r)/8c, \text{ and } \sigma\omega^2r^3(4k-5r)/8c.$$

67. If the particles of a spherical soap-bubble, of radius  $r$  and tension  $t$ , repel each other according to the law of the inverse square of the distance, and if  $V$  be the potential, prove that  $V^2=16\pi rt$ .

68. Into a spherical brass shell, of radius  $a$ , water is forced until the radius of the shell is found to expand to  $r$ . Having given that the coefficient of elasticity of the shell for stretching is  $\mu$ , and that the compressibility of water is  $\lambda$ ; shew that the quantity of water in the shell is

$$\frac{4}{3}\pi\rho\left(\frac{ar^4}{\omega r - 2\lambda\mu(r-a)}\right)$$

where  $\rho$  is the density of uncompressed water.

In the previous question you are given  $a=4$ ,  $r=5$  centims.: and the following data:—

The compression of water for 1 atmos. (1 megadyne per sq. cm.)= $10^{-6} \times 5$ ; thickness of shell= $\cdot 5$  mm., and a brass wire of 1 sq. mm. section requires a force of 9000 megadynes to double its length, if its elasticity remain constant. Determine the measures in c.g.s. units of the quantities involved, and thence shew that the mass of water in the sphere= $535$  grams approximately.

69. A hemispherical bubble is floating on water. Assuming that its radius is such that the ratio of the difference of the internal and external pressures to the external pressure is a small quantity whose square may be neglected, find the form of the water surface inside the bubble, and shew that its greatest depression below the external water surface is

$$2a^2 \left\{ 1 - \int_{-\pi}^{\pi} \frac{r}{ea} \sin\phi \, d\phi \right\},$$

where  $r$  is the radius of the bubble and  $a^2$  the ratio of the surface energy for air and water per unit area to the weight of unit volume of water.

(Mr Burnside.)

70. Giffard's freezing machine consists of two cylinders, the pistons of which work on to two cranks on the same shaft, driven by an external source of power, and of a large air reservoir which is always maintained at the temperature of the external air. In the first cylinder air is compressed till its pressure is the same as in the reservoir, when valves open and the air passes, as the stroke is completed, into the reservoir. The second and smaller cylinder acts as an engine receiving compressed air from the reservoir for such a portion of the stroke that being expanded for the remainder of the stroke it is discharged at atmospheric pressure, but at a lower temperature. If  $V_1$  and  $V_2$  be the volumes of the cylinders, and if the compression and expansion be supposed adiabatic, prove that the work done during each stroke in the first cylinder is  $\Pi V_1 \frac{\gamma}{\gamma-1} \cdot \frac{V_1 - V_2}{V_2}$ , and in the second cylinder is  $\Pi \frac{\gamma}{\gamma-1} (V_1 - V_2)$ ,  $\Pi$  being the atmospheric pressure.

(Dr Hopkinson.)

71. A spherical homogeneous solid earth, supposed to be fixed, is surrounded by a shallow sea, which is attracted by a distant fixed body; prove that, neglecting the attraction of water on itself, the surface of the sea will remain spherical, but that its centre will deviate from the centre of the earth by a distance amounting to the same fraction of its radius that the attraction of the disturbing body is of the attraction of the earth on an element of the liquid.

72. If the earth be supposed spherical and covered with an ocean of small depth, and if the attraction of the particles of water on each other be omitted, the ellipticity of the ocean spheroid will be given by the equation,

$$2\epsilon = \frac{\text{centrifugal force at the equator}}{\text{force of gravity at the earth's surface}}$$

73. A small quantity of fluid is spread over the surface of a material prolate spheroid. Shew that the free surface of the fluid is also a spheroid, and that the depth of the fluid at the equator is to the depth at the pole as the major axis of the spheroid is to the minor.

74. If the earth be completely covered by a sea of small depth, prove that the depth in latitude  $l$  is very nearly equal to  $H(1 - \epsilon \sin^2 l)$ , where  $H$  is the depth at the equator, and  $\epsilon$  the ellipticity of the earth.

75. If the particles of a mass of liquid, rotating uniformly about a fixed axis, attract one another according to such a law that the surfaces of equal pressure are similar coaxial oblate spheroids, prove that the resultant attraction of a spheroid, the particles of which attract according to the same law, is the resultant of two forces perpendicular to the equator and the axis of revolution respectively, and varying as the distance of the attracted point, respectively, from the equator and the axis.

76. In the case of Art. (194), prove that the mean pressure throughout the liquid is  $\frac{2}{3}$  of the pressure at the centre of the ellipsoid: and if the equation of the free surface is

$$x^2/a^2 + y^2/b^2 + z^2/c^2 = 1,$$

and the mass of the liquid is  $M$ , prove that the kinetic energy of the system is

$$\frac{1}{10} M \{2Cc - Aa - Bb\},$$

where  $A, B, C$  are the forces at the ends of the axes  $x, y, z$  due to the attraction of the liquid, the rotation being round the axis of  $z$ .

77. In the case of Art. (188), find the pressure at any point of the interior of the liquid mass when  $\lambda$  is so small that powers beyond  $\lambda^2$  may be neglected.

In this case, if  $n$  is the ellipticity, prove that the pressure on the equatorial plane will be approximately equal to  $(5 - 6n)(\pi\rho a^2)^2/15$  astronomical units of force, where  $a$  is the equatorial radius.

78. An infinite mass of uniform gravitating liquid of density  $\rho$  surrounds an infinitely long thin rigid cylinder of which the section is an ellipse of axes  $2a'$  and  $2b'$ . The liquid and the cylinder rotate with uniform angular velocity  $\omega$  about the axis of the cylinder; prove that a possible form of the free surface of the liquid is a confocal elliptic cylinder of axes  $2a$  and  $2b$ , such that

$$\omega^2(a+b)^2 = 4\pi\rho(ab - a'b').$$

79. A mass ( $M$ ) of homogeneous liquid revolves in relative equilibrium about a fixed axis with a uniform angular velocity such that the ellipticity ( $\epsilon$ ) of its surface is small. If the part  $\mu M$  of the mass were collected into an infinitely dense material point at the centre, and the density of the remaining part  $(1 - \mu)M$  were diminished in the ratio of  $1 - \mu$  to 1, find what would be the ellipticity of the new surface of equilibrium, supposing the time of rotation to be the same as before.

80. A solid ellipsoid of uniform density being supposed to revolve round its least axis of figure, and to carry with it a surrounding envelope of homogeneous liquid of different density, the entire mass attracting according to the law of nature, it is required to find the conditions requisite for the permanent assumption of the ellipsoidal form by the free surface. (Prof. Townsend, *Math. of Ed. Times*, Vol. xxxv.)

81. A number of solid spheres of density  $\rho + \sigma$  are in equilibrium in a fluid of density  $\rho$ , the whole filling a hollow sphere. Prove that, if the whole mass be gravitating, the centre of mass of the spheres must be at the centre of the hollow sphere; also that, if there be only two spheres, the pressure between them at their point of contact is

$$\frac{1}{6} \pi^2 a^3 b^3 \sigma \left\{ a^2 - \frac{\rho}{a+b} + \frac{\sigma}{(a+b)^2} \right\},$$

where  $a, b$  are the radii of the spheres.

82. In the interior of an otherwise solid homogeneous ellipsoid there exists a concentric spherical cavity full of incompressible and homogeneous fluid, the whole matter attracting according to the law of nature. Shew that the surfaces of equal pressure are conicoids; and that, if  $P$  be any point of a determinate surface of the system, the resultant fluid pressure across the plane drawn through the centre  $O$  perpendicular to  $PO$  is  $H + K/OP^2$ , where  $H, K$  are constants depending on the surface of equal pressure chosen.

83. Shew that a diving bell suspended by a chain and totally immersed in the water will not remain with its axis vertical unless

$$W \left( 1 - \frac{1}{s} \right) d - W' d' - \frac{Ak^2 W'}{V}$$

is positive, where  $W$  and  $W'$  are the weights of the bell and the fluid displaced by the air inside,  $V$  the volume of the air inside,  $s$  the s.g. of the substance of the bell,  $1k^2$  the moment of inertia of the cross section at the level of the water inside,  $d$  and  $d'$  the depths of the centre of gravity of the bell and the volume  $V$  below the point of the bell to which the chain is attached.

84. A diving bell is bounded internally by a paraboloid of revolution; its height is  $b$  and the radius of the base  $a$ . When the depth of the base below the surface is  $l$ , prove that the water will have risen a distance  $h$  in the bell, where

$$Hh(2b-h) = (l-h)(b-h)^2,$$

$H$  being the height of the water barometer.

Also if the bell, supposed wholly submerged, be displaced through a small angle  $\theta$ , prove that the righting moment is

$$\{C - \pi \sigma g a^2 (b-h)^2 (4b^2 - 4bh + 3a^2) / 12b^2\} \theta,$$

where  $C$  is a constant, independent of  $h$ , and  $\sigma$  the density of water.

85. A number of liquids of densities  $\rho_1, \rho_2, \dots, \rho_n$  are in equilibrium in a gravitational field of force. Prove that the work done against the fluid pressure in slowly pushing a solid sphere whose volume  $v$  is small in comparison with that of each of the liquids, and which is originally completely immersed in the outermost liquid  $\rho_n$ , until it is completely immersed in the innermost liquid  $\rho_1$ , is approximately

$$v \{ (V_{-1} V_2) \rho_1 + (V_2 - V_3) \rho_2 + \dots + (V_{n-2} V_{n-1} - V_n) \rho_{n-1} + (V_{n-1} V_n - V') \rho_n \},$$

where  $V, V'$  are the potentials at the centre of the sphere in its new and original positions, and  $V_1, V_2, V_3, \dots, V_n$  are the potentials at the surfaces of separation.

86. Two homogeneous spheres, of radii  $b$  and  $b'$  and of densities  $\sigma$  and  $\sigma'$ , are immersed at rest in an incompressible homogeneous fluid of density  $\rho$ , the masses being measured in gravitational units. The whole mass is enclosed in a rigid spherical envelope which just contains it. Prove that all the forces of attraction and pressure on the sphere of density  $\sigma$  can be combined into a repulsive force  $\frac{1}{6}\pi^2\rho(\rho-\sigma)b^3c$  from the centre of the enclosing envelope, and a repulsive force  $\frac{16\pi^2(\rho-\sigma)(\sigma'-\rho)b^3b'^3}{9d^2}$  from the centre of the other sphere; where  $c, d$  are the distances of the centre of the sphere considered from the centre of the envelope and the centre of the other sphere.

87. An attracting mass of which the surface is an equipotential surface is surrounded by fluid whose attraction on itself is neglected: prove that the pressure at any point is less than the pressure at the surface by

$$\frac{1}{4\pi\mu M} \iiint \rho R^2 dx dy dz,$$

where  $R$  is the resultant force,  $M$  the total attracting mass,  $\mu$  the constant of attraction, and the integration is throughout the volume between the two surfaces of equipressure.

88. A homogeneous gravitating solid of volume  $\frac{1}{3}\pi h^3$  and density  $\rho + \sigma$ , in the form of the *very nearly spherical* ellipsoid

$$S \equiv ax^2 + by^2 + cz^2 + 2fyz + 2gzx + 2hxy = 1,$$

is surrounded by gravitating liquid of volume  $\frac{4}{3}\pi(H^3 - h^3)$  and density  $\rho$ . Shew that a possible form of the free surface when the system is in equilibrium is the ellipsoid

$$x^2 + y^2 + z^2 - H^2 = \lambda \{h^2 S - (x^2 + y^2 + z^2)\},$$

where

$$\lambda = -3h^3\sigma/H^2(2H^3\rho + 5h^3\sigma).$$

89. A small arbitrary displacement is given to a perfect fluid at every point of it, the components of the displacement of any point parallel to the axes being  $\delta x, \delta y, \delta z$ ; where  $\delta x, \delta y, \delta z$  are arbitrary continuous functions of  $x, y, z$ . Prove that the total work done by the pressure throughout the volume is

$$\iiint \rho \left( \frac{\partial \delta x}{\partial x} + \frac{\partial \delta y}{\partial y} + \frac{\partial \delta z}{\partial z} \right) dx dy dz;$$

where  $\rho$  is the pressure at any point and the integration is taken throughout the volume. Hence prove that the condition for the equilibrium of the fluid is

$$d\rho = \rho(Xdx + Ydy + Zdz);$$

where  $\rho$  is the density and  $X, Y, Z$  the components of the attractive force per unit mass.







