

UNIVERSAL
LIBRARY

OU_166130

UNIVERSAL
LIBRARY

OSMANIA UNIVERSITY LIBRARY

Call No. 540 K 810

Accession No. 15628

Author Kothoff, I.M.

Title Chlorimetric and ~~photo~~ potentiometric determination of pH.

This book should be returned on or before the date last marked below.

The
Colorimetric and Potentiometric
Determination of pH .

WORKS OF
DR. I. M. KOLTHOFF
AND
N. HOWELL FURMAN, Ph.D.

Volumetric Analysis.

By DR I. M. KOLTHOFF With the collaboration of DR ING. H. MENZEL, Dresden, Germany. An authorized translation, based upon the German edition, by N. HOWELL FURMAN

Vol. I: The Theoretical Principles of Volumetric Analysis. 289 pages. 20 figures. 6 tables. Cloth 6 by 9.

Vol II: Practical Volumetric Analysis. 552 pages 18 figures. Cloth 6 by 9

Potentiometric Titrations.

A Theoretical and Practical Treatise. 345 pages 45 figures. Cloth. 6 by 9.

Indicators.

Their Use in Quantitative Analysis and in the Colorimetric Determination of Hydrogen-Ion Concentration. By DR. I. M. KOLTHOFF An Authorized Translation, based upon the Second German Edition, by N. HOWELL FURMAN, Ph D. 269 pages. 23 figures. Cloth. 6 by 9

By DR. I. M. KOLTHOFF

Determination of pH . Electrometric Titrations.

Colorimetric, potentiometric and conductometric titrations 167 pages 35 figures. Tables Cloth. 6 by 9

PUBLISHED BY
JOHN WILEY & SONS, INC.

The Colorimetric and Potentiometric Determination of pH .

OUTLINE OF
ELECTROMETRIC TITRATIONS

BY

I. M. KOLTHOFF, PH.D.

Professor of Analytical Chemistry in the University of Minnesota

NEW YORK
JOHN WILEY & SONS, INC.
LONDON: CHAPMAN & HALL, LIMITED
1931

COPYRIGHT, 1931,
BY
ISAAC M. KOLTHOFF

All Rights Reserved
This book or any part thereof must not
be reproduced in any form without
the written permission of the publisher.

PRINTED IN U. S. A.

PRESS OF
BRAUNWORTH & CO., INC.
BOOK MANUFACTURERS
BROOKLYN, NEW YORK

PREFACE

A GREAT number of text books on the measurement and significance of hydrogen ion concentrations in various fields have been published in recent years, the most outstanding of which is that by W. Mansfield Clark, *The Determination of Hydrogen Ions* (Third Edition, Williams and Wilkins Co., Baltimore, 1928.)

Other monographs, each with its own merits, are:

H. T. S. Britton, *Hydrogen Ions, Their Determination and Importance in Pure and Industrial Chemistry* (D. Van Nostrand Co., New York, 1929).

L. Michaelis, *The Hydrogen Ion Concentration, Its Significance for Biology and Its Measurement* (Berlin, 1914, Julius Springer, in German): Second Edition (theoretical only), translated by W. A. Perlzweig: (Williams and Wilkins Co., 1926).

W. Kopaczewski, *Les ions d'hydrogène, Signification, Mesure, Applications, Données numériques* (Gauthier-Villars & Cie, Paris, 1926).

E. Mislowitz, *Die Bestimmung der Wasserstoffionenkonzentration von Flüssigkeiten* (Julius Springer, Berlin, 1928).

All these monographs offer a more or less complete discussion of the colorimetric and potentiometric measurement of hydrogen ion concentrations and are based on the pioneer work done by S. P. L. Sørensen, the study of which is recommended to any student in this field.

S. P. L. Sørensen, *The Measurement and Importance of the Hydrogen Ion Concentration in Enzymatic Reactions* (in French): *Compt. rend. du Lab. de Carlsberg*, 8, 1, 396 (1909); (in German): *Biochem. Z.*, 21, 131, 201 (1909); 22, 352 (1909).

More detailed discussions of the properties of acid-base indicators and their application to volumetric analysis and to the determination of pH have been given in the following monographs:

N. Bjerrum, *Die Theorie der alkalimetrischen und azidimetrischen Titrierungen* (Stuttgart, 1914).

A. Thiel, *Der Stand der Indikatorenfrage, zugleich ein Beitrag zur chemischen Theorie der Farbe* (Stuttgart, 1911).

E. B. R. Prideaux, *The Theory and Use of Indicators*. An account of the chemical equilibria of acids, alkalies and indicators in aqueous solutions, with applications (London, 1917).

I. M. Kolthoff, *The Use of Indicators*. Translated from the second German edition by N. H. Furman (John Wiley & Sons, New York, 1926).

The following monographs on electrometric titrations have been published:

I. M. Kolthoff and N. H. Furman, *Potentiometric Titrations*, Second Edition (John Wiley & Sons, New York, 1931).

Erich Müller, *Die electrometrische (potentiometrische) Massanalyse*, Fourth Edition (Th. Steinkopff, Dresden, 1926).

I. M. Kolthoff, *Konduktometrische Titrationen* (Th. Steinkopff, Dresden, 1923).

Though the determination of hydrogen ion concentrations and the application of electrometric titrations are treated in any elementary course of physical chemistry, the subjects have grown to such an importance in pure and applied chemistry as to justify special comprehensive courses for all students in chemistry. This is done at the University of Minnesota, where the seniors (after having finished a fifteen-credit course in physical chemistry in their junior year) are required to take a three-credit course in indicators (one quarter) and a three-credit course in electrometric measurements and titrations (one quarter). It may be mentioned that students in allied fields, such as biochemistry, physiological chemistry, bacteriology, pharmacy, etc., frequently elect these courses. In offering them the author has experienced difficulty in recommending any of the monographs listed above for use as a text book, since all of them are too highly specialized for the purpose.

The present monograph has been written with the idea of offering an introduction to the above fields without claiming in any way an exhaustive treatment. The theory has been given in a condensed form and the student is repeatedly referred to general text-books of physical chemistry and monographs on specific subjects which may be found in any library. The description of apparatus is short, and the student has to make an elaborate report of all his experimental work. If enough time is available, he may take a special course later to familiarize him-

self with different types of instruments, such as colorimeters for one- and two-color measurements, spectrophotometers, various types of potentiometers and balancing systems, null-point instruments, modified Wheatstone bridges for conductivity work, etc.

The main purpose of this outline is to offer enough material to enable the student to apply the important methods to his own specific problem of research.

At the end of this text a scheme for a comprehensive practical course covering the fundamentals of the subjects has been added. It has been the experience of the author that simple procedures, such as the preparation of indicator and buffer solutions, should be included, for he has frequently noticed an astonishing display of ignorance by students in such elementary work. The practical work should be directed in such a way that the student sets up the required apparatus himself without relying too much on the instructor. A little supervision will insure that no time is wasted. As a matter of fact, it is not necessary for each student to prepare a complete set of indicators and buffer solutions; this work can be divided among the participants in the course.

Frequent discussion of the results of the practical work is desirable and, therefore, small classes are advantageous (not more than eight in each section). The student is expected to hand in a detailed report of all work, as it is not only the result of the determination itself which counts, but also (and much more important) the interpretation and understanding of all phenomena observed in the practical work. Without advocating careless work, it is still inadvisable to exaggerate precision unduly, as the main purpose is to familiarize students with the field and its significance; this should be the leading thought in presenting the course. Students who desire to study methods more in detail should be given the opportunity to do so later in special advanced courses. However, the problems included in this text are not too simple, and their solution requires a thorough understanding of the fundamentals of electrochemistry.

With two lectures and four laboratory hours a week, it is possible to cover the fundamentals of the colorimetric and potentiometric methods in two quarters or about one semester.

Finally, the author wishes to express his sincere appreciation to Dr. L. A. Sarver, member of the staff of Analytical Chemistry at the University of Minnesota, for his assistance in correcting the manuscript.

THE AUTHOR.

MINNEAPOLIS, MINN.

CONTENTS

PART I

THE COLORIMETRIC DETERMINATION OF pH ACID-BASE EQUILIBRIA

CHAPTER I

ACIDS AND BASES; THE REACTION OF AQUEOUS SOLUTIONS

PAGES

1. Electrolytes. 2. Ion Concentration and Ion Activity. 3. Acids and Bases. 4. The Dissociation of Water, the Expression of the Reaction; the Hydrogen Ion Exponent. 5. The Reaction of Solutions of Weak Acids and Weak Bases. 6. Hydrolysis of Salts. 7. The Reaction in a Mixture of a Weak Acid and Its Salt, or a Weak Base and Its Salt; Buffer Solutions. Problems 1-24

CHAPTER II

* INDICATORS

1. Color Change of Acid-Base Indicators and pH Range of Color Change. 2. Preparation of Indicator Solutions. 3. Influence of the Concentration of the Indicator, the Temperature and the Medium upon the Color of an Indicator. 24-35

CHAPTER III

THE COLORIMETRIC MEASUREMENT OF pH

1. Principle of the Method. Selected Sets of Buffer Mixtures. 2. The Colorimetric Measurement with Buffer Solutions. 3. The Colorimetric Measurement without Buffer Solutions. 4. Colored Solutions; Compensation for Own Color. 5. Sources of Error in the Colorimetric Method. Problems on Indicators. 35-63

PART II

THE POTENTIOMETRIC MEASUREMENT OF pH .
POTENTIOMETRIC TITRATIONS

CHAPTER IV

ELECTRODE POTENTIALS

PAGES

1. The Potential of a Metal Electrode. 2. Oxidation-reduction Potentials. 3. Concentration Cells and the Theory of the Hydrogen Electrode. Correction for the Pressure. 4. Liquid Junction Potential. 5. The Use of Reference Electrodes (Standard Half-cells) 63-82

CHAPTER V

THE TECHNIQUE OF POTENTIOMETRIC
MEASUREMENTS

1. Principle of the Compensation Method for the Determination of the Electromotive Force of a Cell. 2. General Equipment for Potentiometric Measurements. 3. The Potentiometer System. 4. The Thermionic Valve Method. 5. Reference Electrodes. 82-96

CHAPTER VI

THE POTENTIOMETRIC MEASUREMENT OF THE
HYDROGEN ION ACTIVITY

1. The Hydrogen Electrode. 2. The Quinhydrone Electrodes. 3. The Oxygen and Air Electrodes. 4. Metal-metallic Oxide Electrodes. 5. The Glass Electrode 96-114

CHAPTER VII

POTENTIOMETRIC TITRATIONS

1. The Theory of Potentiometric Titrations; the Equivalence Potential. 2. Titration Curves. 3. The Detection of the Equivalence Point in Potentiometric Titrations. 4. Special Determinations. Problems in Potentiometry. 114-132

PART III

CONDUCTOMETRIC TITRATIONS

CHAPTER VIII

CONDUCTOMETRIC TITRATIONS

	PAGES
1. The Principles of Conductometric Titrations. 2. The Performance of Conductometric Titrations. 3. The Application of Conductometric Titrations to Acid-Base Reactions. 4. The Application of Conductometric Titrations to Precipitation and Complex Formation Analysis. Problems.	132-153

PRACTICAL COURSE

I. INDICATORS	153
II. POTENTIOMETRY.	153
III. CONDUCTOMETRIC TITRATIONS.	154
LOGARITHMS AND ANTILOGARITHMS.	156
INDEX OF AUTHORS.	161
INDEX OF SUBJECTS.	163

THE DETERMINATION OF pH . ELECTROMETRIC TITRATIONS

PART I

THE COLORIMETRIC DETERMINATION OF pH . ACID-BASE EQUILIBRIA

CHAPTER I

ACIDS AND BASES; THE REACTION OF AQUEOUS SOLUTIONS

1. Electrolytes.—Electrolytes dissolved in water are more or less dissociated into ions (theory of Sv. Arrhenius), and the fraction of one gram molecule dissociated is called the degree of electrolytic dissociation. A distinction may be made between *strong* and *weak* electrolytes. According to the modern views on electrolytic dissociation strong electrolytes are completely ionized in aqueous solutions, whereas in solutions of weak electrolytes some undissociated molecules occur. The distinction between the two groups is not very sharp, and many intermediate cases occur. Hydrochloric acid, e.g., is considered as a strong electrolyte, though in 0.1 N solution undissociated molecules occur. However, the concentration of the latter with regard to that of the ions is so small that the acid virtually can be considered as completely ionized. Salts of alkali and alkaline earth metals, the alkali hydroxides, various inorganic acids such as perchloric acid, the halide acids and nitric acid belong to the strong electrolytes. The organic acids and bases are weak electrolytes, though their degree of dissociation under comparable conditions will vary considerably. (Cf. Chapter I, paragraph 5.)

2. Ion Concentration and Ion Activity.—The ion concentration of a solution of a strong electrolyte is equal to its analytical concentration, as the electrolyte is completely ionized. Therefore in 0.1 molar solution of hydrochloric acid, the $[H^+]$ is equal to $[Cl^-] = 0.1$ (the symbols between brackets represent ion concentrations); in 0.1 molar barium chloride $[Ba^{++}] = 0.1$, $[Cl^-] = 0.2$. If α is the fraction of a gram molecule of a weak electrolyte dissociated into the ions, and c its analytical concentration in moles per liter, then αc is the concentration of the ions in the solution, and $(1 - \alpha)c$ that of the undissociated molecules.

In the exact discussion of chemical equilibria one has to realize that the equilibrium conditions are not determined by the actual concentrations of the reacting components but by the corresponding activities.¹

In dilute solutions of non-electrolytes the activity is proportional to the concentration. As the proportionality factor is not known, the activity is conventionally assumed to be equal to the concentration of the non-electrolyte. It should be realized, however, that changing the composition of the solvent will cause a change in the true activity of the dissolved component.

Neutral salts as a rule decrease the solubility of non-electrolytes in water, and therefore the activity of the solute increases correspondingly. On the other hand, addition of alcohol to a solution of an organic acid as a rule increases the solubility, and the activity of the solute decreases correspondingly. In the general and simple derivations in this text it will be assumed that in dilute aqueous solutions of non-electrolytes the concentration and activity are identical.

In infinitely dilute solutions of electrolytes the activity of the ions is assumed to be equal to the corresponding concentration. This does not hold any longer at finite concentrations, as on account of their high electric charge the ions exert enormous

¹ A thermodynamical treatment of activity in general is given in G. N. Lewis and M. Randall, *Thermodynamics and the Free Energy of Chemical Substances*. McGraw-Hill Book Co., New York, 1923.

forces (interionic forces) upon each other; consequently, in the neighborhood of a cation there will be more anions present than ions of the same sign, while more cations than anions will be present in the neighborhood of an anion. On account of the interionic effect in dilute solutions, the activity coefficient of the ions decreases with increasing ion concentration.

The following relation exists between the concentration c_I and the activity a_I of an ion:

$$a_I = c_I f$$

where f represents the so-called *activity coefficient*.

Theoretically it has been derived by Debye and Hückel (1923) that in very dilute solutions the activity coefficient of an ion can be calculated by means of the equation:

$$-\log f = A z_i^2 \sqrt{u}$$

where A is a constant, which is a linear function of the dielectric constant of the solution. In aqueous medium at room temperature it is approximately equal to 0.5 (at 15°, 0.495; at 18°, 0.498; at 25°, 0.501), z_i is the valence of the ion, and as this factor occurs in the square in the equation, it is evident that the activity of a divalent ion, for example, decreases much more with the ionic strength than that of a monovalent ion. u denotes the so-called *ionic strength*, an expression introduced by G. N. Lewis. Its value depends upon the concentration and the valence of the ions. If c represents the ion concentration, then:

$$u = \frac{c_1 z_1^2 + c_2 z_2^2 + \dots + c_n z_n^2}{n} = \frac{\sum c z^2}{n}$$

0.01 molar KCl:

$$u = \frac{0.01 z_K^2 + 0.01 z_{Cl}^2}{2} = 0.01;$$

0.01 molar BaCl₂:

$$u = \frac{0.02 z_{Cl}^2 + 0.01 z_{Ba}^2}{2} = 0.03;$$

0.01 molar AlCl₃:

$$u = \frac{0.03 z_{Cl}^2 + 0.01 z_{Al}^2}{2} = 0.06.$$

If we are dealing with uni-univalent electrolytes the ionic strength is equal to the analytical concentration, and the simple Debye-Hückel equation can be written:

$$-\log f = 0.5\sqrt{c}.$$

This equation only holds up to relatively small ionic strengths (for uni-univalent electrolytes up to about 0.01); in more concentrated solutions the expression is more complicated and can be written quite generally:

$$-\log f = 0.5z_1^2 \frac{\sqrt{u}}{1 + 0.329 \cdot 10^8 \cdot b\sqrt{u}} - Bu,$$

where b is more or less a constant, giving an approximate value of the ionic size (expressed in cm.), and B is another constant, accounting for the salting-out effect of the electrolyte. Even this equation holds over only a limited range of ionic strengths.

Empirically, N. Bjerrum² found that over a wide range of concentrations the activity coefficient of a monovalent ion in a uni-univalent electrolyte can be calculated by means of the equation:

$$-\log f = A'\sqrt[3]{c} - B'c$$

where A' and B' are constants, which are different for the various ions. This equation has proved to be useful in many cases, especially where another solvent is taken instead of water.

The very important problem of the activity coefficient of ions cannot be dealt with in this elementary treatise in the exhaustive way, so the student is referred to reviews which have been written on the subject.³

In the general discussion of the reaction of acids, bases, salts, and properties of indicators, concentrations will be written instead of activities. It should be emphasized, however, that in

² N. Bjerrum, *Ergebn. der exakten Naturwiss.*, **5**, 125 (1926).

³ P. Debye and E. Hückel, *Physik. Z.*, **24**, 185 (1923); E. Hückel, *Physik. Z.*, **26**, 93 (1925); especially *Ergebn. der exakten Naturwiss.*, **3**, 199 (1924); V. K. LaMer, *Trans. Am. Electrochem. Soc.*, **51**, 507 (1927); W. M. Clark, *The Determination of Hydrogen Ions*, p. 489; I. M. Kolthoff, *Chem., Weekbl.*, **17**, 250 (1930).

any exact study of a chemical equilibrium this approximation is not allowed. In various cases discussed further on in this text the activity has to be introduced again, to interpret for different phenomena, and it is for this reason that this incomplete and concise chapter on activities has been inserted.

3. Acids and Bases.—According to the classical theory, an acid is a substance which dissociates in aqueous solution into hydrogen ions and anions, whereas a base is split into hydroxyl ions and cations:



NOTE: (1) According to the above definition, a solution of an acid contains free hydrogen ions, hydrogen nuclei, or protons. However, these elementary positive charges cannot exist as such in a solution, but will combine with the solvent, i.e., water:



Therefore, by combination of equations (1) and (3) it is found that the dissociation of an acid in water has to be represented by:



Similarly in pure alcohol we can write:

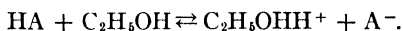

As long as we are only interested in aqueous solutions it is immaterial whether the dissociation of an acid is represented by (1) or (4), if we only realize that all hydrogen ions are present in the hydrated form as hydronium ions (H_3O^+). If the acid character of various substances is compared in different solvents, the ability of the latter to combine with protons should be taken into account.

(2) J. N. Brönsted⁴ has pointed out that the classical terminology of acids and bases is not rational and that any substance having a tendency to split off protons should be called an acid, whereas one which has the property of combining with protons to form an acid should be called a base. Therefore, an acid always forms a conjugated system with a base:

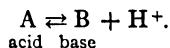

⁴ J. N. Brönsted, *cf. esp. review in Chem. Rev.*, **5**, 231 (1928).

According to this view, water behaves like a base when it combines with protons (eq. 3.), the hydronium ion being the corresponding acid. However, water can also behave like an acid according to the following dissociation:

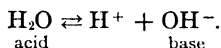

For a general treatment of acid-base properties Brönsted's conceptions are of invaluable importance; however, in this elementary treatise where only systems in water are discussed we will stick to the classical expressions, with which the student is more or less familiar.

4. The Dissociation of Water, the Expression of the Reaction, the Hydrogen-ion Exponent.—The most important reaction between acids and bases in aqueous solution is that between hydrogen and hydroxyl ions:

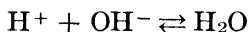

([H⁺] will be quite generally written instead of [H₃O⁺]).

This reaction is reversible, i.e., pure water dissociates, though very slightly, into hydronium and hydroxyl ions. The system being in equilibrium, the mass law expression states:

$$\frac{[\text{H}^+][\text{OH}^-]}{[\text{H}_2\text{O}]} = K. \quad (5)$$

In dilute aqueous solution the concentration (or better the activity) of the water can be considered as being constant, therefore, instead of (5) the following relation can be written:

$$[\text{H}^+][\text{OH}^-] = K_w. \quad (6)$$

K_w is the ionization product of water, which is a constant at a definite temperature. On account of the high heat of reaction between hydronium and hydroxyl ions it may be expected that the constant increases very much with the temperature. This is actually the case, as is shown in the following table. Here the change of $[a_{\text{H}}][a_{\text{OH}}]$, i.e., the product of the activity of the hydronium and hydroxyl ions (*cf.* paragraph 2) is given at tempera-

tures between 10° and 30° C. In the third column the ion product exponent pK_w is given

$$pK_w = -\log K_w.$$

The latter figures are certain to within 0.02.

[a_{H^+}] [a_{OH^-}] BETWEEN 10° AND 30° C.

Temperature	$K_w \times 10^{15}$	pK_w
10	3 0	14.52
15	4 7	14.33
18	6 1	14.22
20	7 2	14.14
23	9 0	14.05
25	10 5	13.98
28	13 2	13.88
30	15 5	13.81

Between 0° and 40°:⁵

$$pK_w = 14.926 - 0.0420t + 0.00016t^2.$$

At 25° K_w is approximately equal to 10^{-14} . This means that in pure water (*cf.* eq. 6):

$$[H^+]^2 = [OH^-]^2 = 10^{-14}$$

and

$$[H^+] = [OH^-] = 10^{-7}. \quad (7)$$

A solution in which $[H^+]$ is equal to $[OH^-]$ is defined as being *neutral*. If $[H^+]$ is greater than 10^{-7} (at 25°), and hence $[OH^-] < 10^{-7}$ the reaction is *acid*; if $[H^+]$ is smaller than 10^{-7} (and $[OH^-] > 10^{-7}$) the reaction is *alkaline*. In all cases the reaction can be quantitatively expressed by the magnitude of the hydronium ion concentration, as there is a simple relation between $[H^+]$ and $[OH^-]$. From equation (6) it follows that

$$[H^+] = \frac{K_w}{[OH^-]}$$

$$[OH^-] = \frac{K_w}{[H^+]}$$

⁵ N. Bjerrum and A. Unmack, Kgl. Dansk. Videnskab. Selskab, **9**, 1 (1929).

For various purposes it has been found more practical to express the hydronium-ion concentration not as such, but rather by its negative logarithm to the base ten. Originally this was proposed by S. P. L. Sørensen (1909), and the terminology has been generally accepted. (He calls the number the *hydrogen exponent* or *hydrogen ion exponent* and designates it by the symbol pH . Thus we have:

$$pH = -\log [H^+] = \log \frac{1}{[H^+]}$$

$$[H^+] = 10^{-pH}$$

In 0.01 N hydrochloric acid $[H^+] = 0.01 = 10^{-2}$, and $pH = 2$.

The hydroxyl ion exponent can be defined in a similar way, and thus we find from equation (6) the simple expression:

$$pH + pOH = pK_w = 14.0 \quad (25^\circ)$$

In pure water $pH = pOH = 7.0 \quad (25^\circ)$.

The reaction of a liquid can be defined in terms of pH . Again at 25° it is found:

$$pH = 7 = pOH \quad \text{neutral reaction}$$

$$pH < 7 < pOH \quad \text{acid reaction}$$

$$pH > 7 > pOH \quad \text{alkaline reaction.}$$

In the beginning the use of the negative logarithm may lead to some confusion. It should be well understood that a decreasing pH means an increasing acidity, and an increasing pH a decreasing acidity.

5. The Reaction of Solutions of Weak Acids and Weak Bases.—According to the classical expression, the dissociation of a weak acid can be represented by the equation:



(better: $HA + H_2O \rightleftharpoons H_3O^+ + A^-$).

According to the law of mass action:

$$\frac{[H^+][A^-]}{[HA]} = K_a \quad (9)$$

K_a denoting the dissociation or ionization constant of the acid, and $[HA]$ the concentration of the undissociated acid. In a pure aqueous solution of an acid

$$[H^+] = [A^-].$$

In such a solution, therefore:

$$\frac{[H^+]^2}{c - [H^+]} = \frac{[A^-]^2}{c - [A^-]} = K_a \quad (10)$$

where c represents the total (analytical) concentration of the acid.

Solving equation (10) for (H^+) :

$$[H^+] = -\frac{K_a}{2} + \sqrt{\frac{K_a^2}{4} + K_a c}. \quad (11)$$

If the degree of ionization of the acid is small (less than about 5 per cent), $[H^+]$ will be very small with regard to c . Under such conditions equation (10) can be written in the *approximated* form:

$$\frac{[H^+]^2}{c} = K_a$$

$$(H^+) = \sqrt{K_a c} \quad (12)$$

$$pH = \frac{1}{2} p_a - \frac{1}{2} \log c, \quad (13)$$

p_a representing $-\log K_a$ or the *acid exponent*. If equation (12) is used, one has to make sure that the approximation is permissible, which can be done by showing that $\sqrt{K_a c}$ is virtually identical with $\sqrt{K_a(c - [H^+])}$.

In the case of a dibasic acid there are two ionization constants:

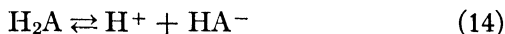

$$K_1 = \frac{[H^+][HA^-]}{[H_2A]} \quad (16)$$

$$K_2 = \frac{[H^+][A^-]}{[HA^-]} \quad (17)$$

For the calculation of (H^+) in the solution of a free dibasic acid one can usually use equation (14) and neglect the second step of dissociation. The problem is then reduced to that of a monobasic acid (equations 11, 12, and 13). The approximation can be made for most ordinary cases, where K_1 and K_2 are considerably different, and the solution of the acid is not too dilute.

If these conditions are not fulfilled, $[H^+]$ can be computed in a relatively simple way by application of the following considerations. As a first approximation in the solution of a dibasic acid:

$$[H^+] = [HA^-].$$

Then we find from equation (17) that $[A^-] = K_2$. From equation (14) and (15) it may be inferred that quite generally

$$[H^+] = [HA^-] + 2[A^-]. \quad (18)$$

Therefore, if we have calculated $[H^+]$ on the assumption that the solution of the free acid behaves only as a monobasic acid, we can decide at once whether it is permissible to disregard the second stage of ionization. If we have calculated $[H^+] = 10^{-3}$, for example, and if $K_2 = 10^{-6}$, the second dissociation does not need to be considered. On the other hand, if the approximated value of $[H^+] = 10^{-4}$ and $K_2 = 10^{-5}$, then $[A^-]$ is approximately 10^{-5} , and the roughly corrected value of (H^+) is:

$$[H^+] = 10^{-4} + 10^{-5} = 1.1 \times 10^{-4},$$

whereas

$$[HA^-] = 10^{-4} - 10^{-5} = 0.9 \times 10^{-4}.$$

Using these corrected values in equation (17) we find that $[A^-] = 0.8 \times 10^{-5}$. By a second approximation we find then $[H^+] = 10^{-4} + 0.8 \times 10^{-5} = 1.08 \times 10^{-4}$, which does not differ materially from the result of the first approximation.

Example.—Tartaric acid

$$K_1 = 10^{-3}; K_2 = 3 \times 10^{-5}; c = 0.1.$$

TABLE: IONIZATION CONSTANT AND pK OF SOME ACIDS AND BASES AT ROOM TEMPERATURE

Name	Constant Acid	pK
Acetic acid	1.86×10^{-5}	4.73
Benzoic acid	6.86×10^{-5}	4.16
Boric acid	6×10^{-10}	9.22
Carbonic acid	3×10^{-7}	6.52
Second step	4.5×10^{-11}	10.35
Citric acid	8×10^{-4}	3.10
Second step	1.77×10^{-5}	4.75
Third step	3.9×10^{-7}	6.41
Formic acid	2×10^{-4}	3.70
Hydrocyanic acid	7×10^{-10}	9.14
Lactic acid	1.5×10^{-4}	3.82
Oxalic acid	5.7×10^{-2}	1.24
Second step	6.1×10^{-5}	4.21
Phenol	1.3×10^{-10}	9.89
Phosphoric acid	8×10^{-3}	2.10
Second step	7.5×10^{-8}	7.13
Third step	5×10^{-13}	12.30
Phthalic acid	1.3×10^{-3}	2.88
Second step	3.9×10^{-6}	5.41
Salicylic acid	1.06×10^{-3}	2.97
Succinic acid	6.5×10^{-5}	4.18
Second step	2.7×10^{-6}	5.57
Tartaric acid	9.7×10^{-4}	3.01
Second step	2.8×10^{-5}	4.55
	Constant Base	
Ammonia	1.75×10^{-5}	4.76
Aniline	4.6×10^{-10}	9.34
Brucine	9×10^{-7}	6.04
Ethylamine	5.6×10^{-4}	3.25
Diethylamine	1.3×10^{-3}	2.90
Triethylamine	6.4×10^{-4}	3.19
Methylamine	5×10^{-4}	3.30
Hydrazine	3×10^{-6}	5.52
Hydroxylamine	1×10^{-8}	8.00
Pyridine	1.4×10^{-9}	8.85

From equation (11), it is found:

$$[\text{H}^+] = 9 \times 10^{-3}.$$

$$[\text{A}^-] = 3 \times 10^{-5}.$$

The second dissociation step may be neglected.

$c = 0.001$: From equation (11):

$$[\text{H}^+]_{\text{appr.}} = 6.2 \times 10^{-4},$$

whereas

$$[\text{A}^-]_{\text{appr.}} = 3 \times 10^{-5},$$

$$[\text{H}^+]_{\text{corr.}} = 6.2 \times 10^{-4} + 0.3 \times 10^{-4} = 6.5 \times 10^{-4}.$$

The considerations which have been advanced for acids hold equally well for bases, except that in the latter case $[\text{OH}^-]$ is calculated. The corresponding $[\text{H}^+]$ can be calculated from the ionization product of water (equation 6).

At the end of this paragraph we want to emphasize the great difference between the acidity found by *titration* and the *actual* or *true* acidity, corresponding to the hydrogen-ion concentration of the solution. So, for example, 0.1 N hydrochloric and 0.1 N acetic acid have the same titration acidity, whereas in the former $[\text{H}^+] = 10^{-1}$, in the latter 1.35×10^{-3} .

6. Hydrolysis of Salts.—In any aqueous solution the amphoteric property of the water, quantitatively expressed by its ionization product, has to be considered. By virtue of its amphoteric properties water can act as a weak acid or a weak base; this hybrid character enters on the foreground in the consideration of the reaction of a salt solution. A salt of a strong acid and a strong base, like sodium chloride potassium nitrate, does not change the reaction of the solvent, as neither the anion of the acid has a tendency to combine with hydrogen ions, nor the cation to combine with hydroxyl ions.

However, the salt of a strong base and a weak acid as a rule behaves like a strong electrolyte and is completely ionized into the ions. The anion A^- on account of its basic character (*cf.*

definition of Brönsted, paragraph 3) may interact with the water:

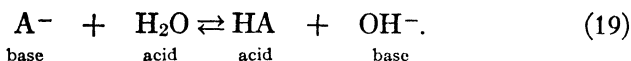

By this reaction hydroxyl ions are formed and the reaction of the water is shifted to the alkaline side. The cation B^+ (like NH_4^+) in a salt of a weak base and a strong acid, on account of its acid properties will react with the base water:

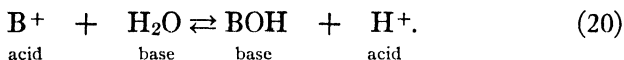

Therefore, salts of weak bases and strong acids show an acid reaction in aqueous medium.

From equation (19) it is evident that *quantitatively* the degree of hydrolysis of a salt of a weak acid and a strong base will be determined by the magnitude of the ionization constant of the acid and the ionization product of water. Similarly, the hydrolysis of a salt of a weak base and a strong acid is determined by the ionization constant of the base and the ionization product of water, and it is a simple matter to calculate the hydrogen-ion concentration in such hydrolyzed salt solutions. By application of the law of mass action to equation (20) we find:

$$\frac{[\text{BOH}][\text{H}^+]}{[\text{B}^+]} = K_{\text{hydr.}} \quad (21)$$

$K_{\text{hydr.}}$ is usually denoted as the *hydrolysis constant*.

We know that

$$K_b = \frac{[\text{B}^+][\text{OH}^-]}{[\text{BOH}]}$$

Then we find (equation 21):

$$\frac{[\text{BOH}][\text{H}^+][\text{OH}^-]}{[\text{B}^+][\text{OH}^-]} = \frac{K_w}{K_b} = K_{\text{hydr.}} \quad (22)$$

By the hydrolysis the amount of $[\text{BOH}]$ and $[\text{H}^+]$ formed (equation 20) will be equal, and therefore in a solution of the pure salt in water $[\text{BOH}]$ can be put equal to $[\text{H}^+]$. If the salt

behaves as a strong electrolyte, and has a concentration c in water, $[B^+] = c$. Therefore we find in a solution of a salt of a weak base and a strong acid in water, that:

$$\frac{[\text{BOH}][\text{H}^+]}{[\text{B}^+]} = \frac{[\text{H}^+]^2}{c} = K_{\text{hydr.}} = \frac{K_w}{K_b}$$

and

$$[\text{H}^+] = \sqrt{\frac{K_w c}{K_b}} \quad (23)$$

$$p\text{H} = 7 - \frac{1}{2}p_b + \frac{1}{2}p_c \quad (25^\circ). \quad (24)$$

In a similar manner it can be derived that in a salt of a weak acid and a strong base:

$$\frac{[\text{HA}][\text{OH}^-]}{[\text{A}^-]} = \frac{[\text{OH}^-]^2}{c} = K_{\text{hydr.}} = \frac{K_w}{K_a} \quad (25)$$

and

$$[\text{OH}^-] = \sqrt{\frac{K_w c}{K_a}} \quad (26)$$

or

$$[\text{H}^+] = \sqrt{\frac{K_w K_a}{c}} \quad (27)$$

$$p\text{H} = 7 + \frac{1}{2}p_a - \frac{1}{2}p_c \quad (28)$$

$$(p_c = -\log c).$$

Hydrolysis of a Salt of a Weak Acid and a Weak Base.—In this case the water will react with the cation as well as with the anion:

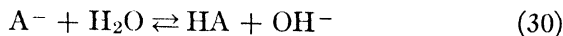
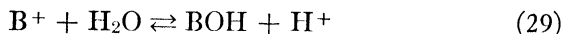

Again, it can be computed that

$$\frac{[\text{BOH}][\text{H}^+]}{[\text{B}^+]} = \frac{K_w}{K_b} \quad (22)$$

$$\frac{[\text{HA}][\text{OH}^-]}{[\text{A}^-]} = \frac{K_w}{K_a} \quad (25)$$

In a solution of a salt of a weak acid and a weak base, $[\text{BOH}]$ is not equal to $[\text{H}^+]$, as the hydrogen ions formed by hydrolysis react with the anions A^- to form HA . If the reaction of the solution is nearly neutral ($p\text{H}$ between 6 and 8), $[\text{H}^+]$ and $[\text{OH}^-]$ are both extremely small, and the amounts of BOH and HA formed by hydrolysis are approximately identical.

By multiplication of (22) and (25), it is found that

$$\frac{[\text{BOH}][\text{HA}]}{[\text{B}^+][\text{A}^-]} = \frac{K_w}{K_a K_b} \quad (31)$$

If the salt is a strong electrolyte, and has a concentration c ,

$$[\text{B}^+] = [\text{A}^-] = c$$

and

$$\frac{[\text{BOH}]^2}{c^2} = \frac{[\text{HA}]^2}{c^2} = \frac{K_w}{K_a K_b}$$

or

$$[\text{BOH}] = [\text{HA}] = c\sqrt{\frac{K_w}{K_a K_b}}. \quad (32)$$

Since $[\text{HA}]$ is known, we may calculate $[\text{H}^+]$:

$$\frac{[\text{H}^+][\text{A}^-]}{[\text{HA}]} = K_a$$

$$[\text{H}^+] = K_a \frac{[\text{HA}]}{[\text{A}^-]} = K_a c \frac{\sqrt{\frac{K_b}{K_a K_b}}}{c} = \sqrt{\frac{K_w K_a}{K_b}} \quad (33)$$

$$p\text{H} = 7 + \frac{1}{2}p_a - \frac{1}{2}p_b \quad (25^\circ). \quad (34)$$

Equation (33) shows that in a solution of a salt of a weak acid and a weak base the hydrogen-ion concentration is independent of the salt concentration.

Reaction of Acid Salts.—Considering an acid salt of the type BHA , which again behaves as a strong electrolyte, it is completely ionized into the ions B^+ and HA^- .

The HA^- ion acts as an acid:

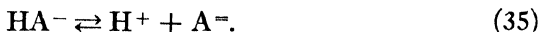

However, since the HA^- is the anion of the weak acid H_2A , part of the ions will react with the hydrogen ions



For this reason $[\text{H}^+]$ is not equal to $[\text{A}^-]$ (equation 35), but will be smaller as part is transformed into H_2A (equation 36).

It is easily seen that:

$$[\text{A}^-] = [\text{H}^+] + [\text{H}_2\text{A}]. \quad (37)$$

The reaction represented in equation (35) is quantitatively governed by the second ionization constant of the acid H_2A , whereas that in equation (36) is governed by the first ionization constant of H_2A .

$$[\text{A}^-] = \frac{[\text{HA}^-]}{[\text{H}^+]} K_2$$

$$[\text{H}_2\text{A}] = \frac{[\text{H}^+][\text{HA}^-]}{K_1}$$

From these two equations and (37) it is found that

$$[\text{H}^+] = \sqrt{\frac{K_1 K_2 [\text{HA}^-]}{K_1 + [\text{HA}^-]}} = \sqrt{\frac{K_1 K_2 c}{K_1 + c}}, \quad (38)$$

if c is the concentration of the salt BHA in the solution. Equation (38) shows that the salt concentration is of minor influence upon the hydrogen-ion concentration of the solution. This is especially true when K_1 is small in comparison with c . In such a case we can write c instead of $K_1 + c$, and equation (38) assumes the following simple form:

$$[\text{H}^+] = \sqrt{K_1 K_2}. \quad (39)$$

A few words may be said of the influence of the *temperature* upon the degree of hydrolysis. For solutions of salts of weak acids and strong bases, weak bases and strong acids, and weak

acids and weak bases, it has been shown that the hydrogen-ion concentration is a linear function of the square root of the ionization product of water (equations 24, 27, 33). It has also been pointed out (p. 6) that the latter increases rapidly with the temperature, and therefore it may be expected that the hydrolysis of such salts will increase appreciably with the temperature. This conclusion is justified by the fact that the ionization constants of most common weak acids and bases change only very slightly with the temperature. Considering a salt like ammonium chloride, it will be found that the ratio of the hydrogen-ion concentrations at a temperature t_1 to that at t_2 is

$$\sqrt{\frac{pK_w(t_1)}{pK_w(t_2)}}$$

in which $pK_w t_1$ is the ionization product of water at a temperature t_1 , $pK_w t_2$ that at the temperature t_2 .

7. The Reaction in a Mixture of a Weak Acid with Its Salts, or a Weak Base and Its Salt. Buffer Solutions.—The dissociation of a weak acid into its ions is governed by the magnitude of the ionization constant:

$$\frac{[H^+][A^-]}{[HA]} = K_a \quad (9)$$

or

$$[H^+] = \frac{[HA]}{[A^-]} K_a \quad (40)$$

If the analytical concentration of the acid is c_a , and that of the salt is c_s , then the concentration of the undissociated part of the acid $[HA]$ is $c_a - [H^+]$, and that of the anions $[A^-]$ is $c_s + [H^+]$. Therefore instead of (40) it can be written:

$$[H^+] = \frac{c_a - [H^+]}{c_s + [H^+]} K_a \quad (41)$$

From this quadratic equation $[H^+]$ can be easily found. As a rule, equation (41) can be applied in a simpler, though approxi-

mated, form. In a mixture of the weak acid and its salt the dissociation of the former is repressed by the common ion effect, and therefore in most practical cases it is found that $[H^+]$ is negligibly small with regard to c_a and c_s . If this is the case, equation (41) is transformed into:

$$[H^+] = \frac{c_a}{c_s} K_a. \quad (42)$$

Example.—The ionization constant of acetic acid is 1.8×10^{-5} . What is the hydrogen-ion concentration in a mixture of 0.05 N acetic acid and 0.05 N sodium acetate?

$$c_a = c_s = 0.05.$$

$$[H^+] = \frac{0.05}{0.05} K_a = 1.8 \times 10^{-5}.$$

The answer indicates that the application of the approximate equation is permissible, as $c_a - [H]^+$ and $c_s + [H]^+$ are virtually identical with c_a and c_s . Only in extreme cases, in which the acid contains only a few per cent of its salt, the quadratic equation has to be applied. Similarly, the hydrolysis of the salt of the weak acid has to be taken into account in the computation of $[H^+]$ in a solution of a salt of the weak acid, containing only a trace of the free acid.

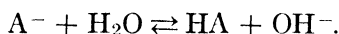

Again, if the analytical concentration of the salt is c_s , and that of the acid c_a , it is found in the latter case that

$$[A^-] = c_s - [OH^-] = c_s(\text{appr}).$$

$$[HA] = c_a + [OH^-].$$

From the hydrolysis equation we know that:

$$\frac{[HA][OH^-]}{[A^-]} = \frac{\{c_a + [OH^-]\}[OH^-]}{c_s} = K_{\text{hydr.}} = \frac{K_w}{K_a}. \quad (25)$$

As $[OH^-]$ is the only unknown in this equation it can be calculated, and from its value $[H^+]$ can be computed.

Mixtures of weak acids and their salts have a tremendous practical significance. They furnish us simple means of preparing *stable solutions of definite pH*. Suppose that it is necessary to prepare a solution with a hydrogen-ion concentration of 1.8×10^{-5} . As hydrochloric acid is a strong acid, the problem could be solved by diluting standard acid to a normality of 0.000018. Anyone familiar with chemical work knows that it is very hard to rely upon such a solution. The carbon dioxide content of the water, a trace of alkali which the glass vessel may yield, or impurities in the air may affect the *pH* of such a dilute solution of a strong acid very much, so that even the order of its magnitude may be different from the calculated one.

The above problem of preparing a stable solution with a $[H]^+$ of 1.8×10^{-5} can be easily solved if we take a mixture containing equivalent amounts of acetic acid and sodium acetate. If the concentration of acid and salt is of the order of 0.1 N, slight amounts of impurities of acidic or basic character will not affect its *pH*, and the solution can be kept in glass bottles without changing its *pH*. Such solutions which resist changes in their reaction are called *buffer solutions* or *buffer mixtures* (sometimes the word *regulator* or *ampholyte* is used). In a similar way it can be shown that a solution of a weak base and its salt exerts a corresponding *buffer action*.

$$[OH^-] = \frac{[BOH]}{[B^+]} K_b = \frac{c_b}{c_s} K_b$$

and

$$[H^+] = \frac{K_w c_s}{K_b c_b} \quad (43)$$

Buffer solutions are of the utmost importance in the colorimetric measurement of the hydrogen-ion concentration (*cf.* p. 35), and therefore their properties may be discussed in a more general way. From the above it is evident that mixtures of weak acids and their salts or weak bases and their salts exert a buffer action. In the preceding paragraph it has been mentioned that the ionization constant of most acids and bases changes

only very slightly with the temperature. Therefore, considering equation (42), it may be expected that the pH of mixtures of weak acids and their salts will be more or less independent of the temperature. Actually it has been shown that the hydrogen-ion concentrations of most buffer mixtures of the type under consideration change very slightly with the temperature. On the other hand, equation (43) informs us that the pH of a mixture of a weak base with its salt will decrease rapidly with the temperature, as K_w is very sensitive to a change in temperature. (Cf. table, p. 7.) For this reason the buffer solutions used for practical purposes are as a rule mixtures of a weak acid with its salt.

Another question of practical importance is: What is the range in pH which can be covered by one acid and its salt? Let us suppose that the ionization constant of the acid is 10^{-5} . Then according to equation (42) a mixture of acid and its salt in a concentration ratio of 100 : 1 has a $[H^+]$ of

$$[H^+] = \frac{c_a}{c_s} K_a = 100 K_a = 10^{-3}; \text{ or } pH = 3.$$

In a mixture of one acid and one hundred salt:

$$[H^+] = \frac{1}{100} K_a = 10^{-7}; \text{ or } pH = 7.$$

Therefore, it might be inferred that with this acid-salt system, buffer solutions with a pH between 3 and 7 could be prepared. This conclusion, however, is not wholly justified. One of the characteristics of a buffer solution is that it resists a change in its reaction, so that the presence of a slight amount of impurities will not affect the pH . Let us now consider the following three buffer solutions:

- I. 0.01 N acid, 0.0001 N salt; $[H^+] = 10^{-3}$; $pH = 3$;
- II. 0.01 N acid, 0.01 N salt; $[H^+] = 10^{-5}$; $pH = 5$;
- III. 0.0001 N acid, 0.01 N salt; $[H^+] = 10^{-7}$; $pH = 7$;

and assume that on keeping 100 c.c. of these mixtures in glass

bottles an amount of alkali corresponding to 0.5 c.c. 0.01 N goes into the solution. By this impurity the pH of the buffer solutions will change:

$$\text{I. } [H^+] = \frac{100}{1.5}K_a = 6.7 \times 10^{-4}; \quad pH = 3.17;$$

$$\text{II. } [H^+] = \frac{99.5}{100.5}K_a = 9.9 \times 10^{-5}; \quad pH = 5.00;$$

$$\text{III. } [H^+] = \frac{0.5}{100.5}K_a = 5 \times 10^{-8}; \quad pH = 7.30.$$

With the same amount of impurity the pH of buffer I changes by 0.17, of II is not affected, of III changes by 0.3. Therefore, the *intensity* of buffer action of the three solutions, which may be expressed as the *buffer capacity* or *buffer action*,⁶ is quite different. A maximum buffer action is observed in the mixture with equal concentration of acid and salt, and it decreases with increasing or decreasing ratio of acid to salt. The buffer intensity also depends upon the total concentration as well as upon the ratio of acid to salt; with increasing amount of acid and salt the buffer intensity increases. For most practical cases buffer solutions are used with a total concentration of acid and salt of the order of 0.05 to 0.1 N. These mixtures are stable approximately within the range 10 acid : 1 salt and 1 acid : 10 salt, or within a pH range:

$$pH = pK_a \pm 1.$$

These limits of course are not exact, but only show the approximate range in pH of stable buffer solutions which can be obtained from an acid of known pK_a . If the solutions are used immediately after their preparation, it is quite possible to prepare them in a range

$$pH = pK_a \pm 2.$$

⁶ Comp. D. D. van Slyke, J. Biol. Chem., **52**, 525 (1922); I. M. Kolthoff, *Indicators*, p. 24.

For the preparation of stable buffer solutions with a pH of 3 to 5, an acid with ionization constant of 10^{-4} can be used; for pH of 5-7, an acid with K_a of about 10^{-6} , etc.

From equation (42) it might be inferred that the hydrogen-ion concentration in a buffer solution depends only upon the ratio of the concentration of acid to salt (and K_a) and not upon the total concentration; in other words, the pH should not change on diluting such a buffer mixture with water. This is approximately, though not entirely, true. The equations have been written in an approximate and not in an exact form. Theoretically the following relation holds:

$$[aH^+] = \frac{[aHA]}{[aA^-]} K_a = \frac{c_a f_0 K_a}{c_s f_{A^-}}$$

$$[aH^+] = \frac{[aHA^-]}{[aA^-]} K_2 = \frac{c_a f_{HA^-} K_2}{c_s f_{A^-}}$$

(buffer mixture of an acid salt and a normal salt).

The symbol a represents the activities of the components, f their corresponding activity coefficients (*cf.* paragraph 2). The activity coefficient of an undissociated acid in dilute aqueous solution is very close to 1, and therefore c_a can be written instead of $[aHA]$. The activity coefficient of an ion, however, decreases with increasing ion concentration in the solution. Therefore, if we dilute a buffer mixture with water, f_{A^-} will increase and consequently $[aH^+]$ will decrease. The change is small but it has to be considered in exact work.

If one should add a neutral salt like potassium chloride to a buffer solution, f_{A^-} would become smaller and the hydrogen-ion activity would increase by such an addition.

The practical applications of the above principles will be discussed in Chapter III.

PROBLEMS

1. What ions are present in a solution of perchloric acid in water, glacial acetic acid, ethyl alcohol, respectively?
2. What is the $[H^+]$ and what is the pH in a 0.005 N HCl, and in a 0.005 N NaOH solution at 10° and at 30° ? (K_w , see p. 7.)
3. What are the values of $[H^+]$, $[OH^-]$, pH , and pOH , respectively, in water at 10° and at 30° ?
4. A 0.1 molar solution of a monobasic acid has a pH of 2.500. Compute its ionization constant.
5. What is the pH in a 1 molar and 0.01 molar solution of an acid with an ionization constant of 10^{-3} ? Compute the same for $K_a = 10^{-5}$.
6. What is the pH in 0.1 molar solution of a chloride of a weak base at 10° and at 30° if $K_b = 10^{-5}$?
7. What is the pH of a 0.1 molar solution of the sodium salt of a weak acid ($K_a = 10^{-6}$) at 10° and at 30° ?
8. What is the pH of pure water in equilibrium with the air, if the latter contains 0.03 vol. per cent CO_2 , and the distribution coefficient of CO_2 between water and air is 1. First Ionization constant of carbonic acid is 3.0×10^{-7} .
9. What is the pH of a solution of ammonium acetate, ammonium formate, ammonium succinate (list of ionization constants, *cf.* p. 11).
10. A solution of a salt of a weak acid and a weak base has a pH of 6.5. Calculate K_b if $K_a = 5 \times 10^{-4}$.
11. How does the pH of an acetate-acetic acid buffer solution change between 25° and 100° , if K_a remains unchanged? How does the pH of an ammonia-ammonium chloride buffer change between 25° and 100° , if K_b remains unchanged? K_w at $25^\circ = 10^{-14}$; at $100^\circ = 10^{-12}$.
12. What will be the approximate value of the ionization constant of an acid for the preparation of buffer solutions with a pH of 11 to 13?
13. A mixture containing 0.04 mole of a monobasic acid and 0.06 mole of its sodium salt per liter has a pH of 5.05. Calculate the ionization constant of the acid, assuming that:
 - a. the activity coefficient of the acid is 1, and of the anion is 1.
 - b. the activity coefficient of the acid is 1, and of the anion is 0.8.
14. What is the pH of the above mixture in the presence of 0.5 mole KCl per liter, assuming that under these conditions the activity coefficient of the acid is 1.2 and that of its anions 0.6?

CHAPTER II

INDICATORS

1. Color Change of Acid-base Indicators and pH Range of Color Change: Indicators behave like weak acids or weak bases, the dissociated and undissociated forms of which have different color and constitution. Therefore, an indicator is comparable to an ordinary weak acid or weak base, and it is possible to interpret the behavior of indicators quantitatively on the basis of the above definition. If we consider the case where the undissociated form of the indicator has acid properties, and denote it as HI, its dissociation is represented by the same equation as that for all weak acids:

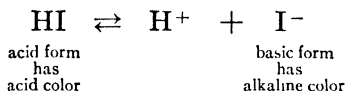

Quantitatively the equilibrium is governed by:

$$\frac{[\text{H}^+][\text{I}^-]}{[\text{HI}]} = K_I, \quad (1)$$

where K_I is the ionization constant of the indicator, often called the *indicator constant*. The color of the indicator in the solution is determined by the ratio $[\text{I}^-]$ to $[\text{HI}]$:

$$\frac{[\text{I}^-]}{[\text{HI}]} = \frac{K_I}{[\text{H}^+]} \quad (2)$$

Therefore, both forms of the indicator are present in the solution at any hydrogen-ion concentration. It is incorrect to speak of the transition *point* of an indicator, since it does not change over suddenly from one form to the other at a definite $[\text{H}^+]$.

The color change takes place gradually, as may be inferred from equation (2); if $[H^+]$ has the same numerical value as K_I the indicator is transformed 50 per cent into the alkaline form; if $[H^+]$ is ten times larger than K_I , about 90 per cent of the indicator is present in the acid form, and 10 per cent in the alkaline form. With increasing $[H^+]$ the concentration of the alkaline form decreases still more. The eye has a limited sensitivity for the observation of colors; only a certain amount of one form can be detected in the presence of the other; so the visible color change of the indicator falls within certain limits of the hydrogen-ion concentration. If the two limits of the perceptible change are expressed in pH , the region between the two limiting values in the interval of change is usually designated as *transition interval* or *color-change interval*. The sharp change from the acid to the alkaline color takes place between the two limiting values, which can be determined experimentally. It should be realized that figures on the color-change interval reported in the literature have only an approximate character; from the above it is evident that the two limiting values depend more or less upon the subjective judgment of the observer. One author, for example, may report the color-change interval of methylorange between pH 2.9 and 4.2, whereas another may put the limits between 3.1 and 4.4. Though at a pH of 3.1 most of the indicator is present in the acid form, one may perceive a variation in the color of the indicator between pH values of 2.9 and 3.1. By spectrophotometric measurements, however, it can be shown that even at a pH of 2.9 about 8 per cent of the indicator is present in the alkaline form. The magnitude of the interval is not the same for all indicators because the sensitivity with which the eye can perceive a small portion of the acid form in the presence of the alkaline form or a small fraction of the alkaline form in the presence of an excess of the acid form will be different for various indicators. In cases where we are dealing with indicators changing from a colorless to a colored form (one-color indicators) the color-change interval is greatly dependent upon the concentration of the indicator.

Assuming that in a given case 9 per cent of the alkaline form can just be detected in the presence of the acid form, we have:

$$\frac{[I^-]}{[HI]} = \frac{1}{10} = \frac{K_I}{[H^+]}$$

The indicator begins to change its color to the alkaline side at:

$$[H^+] = 10K_I,$$

or at

$$pH = p_I - 1,$$

where p_I denotes the negative logarithm of K_I and is called the *indicator exponent*. Assuming further that the indicator is practically completely converted into the alkaline form, when about 91 per cent is present in this form, we have:

$$\frac{[I^-]}{[HI]} = 10 = \frac{K_I}{[H^+]}$$

$$pH = p_I + 1.$$

Therefore, the color-change interval of such an indicator lies at:

$$pH = p_I \pm 1.$$

Actually, it is found that for most indicators the pH range is of the order of 2.

For indicator bases the following relation holds:

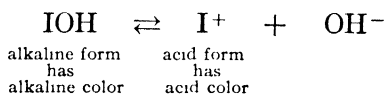

$$\frac{[I^+][OH^-]}{[\text{IOH}]} = K_{\text{IOH}}$$

$$\frac{[\text{IOH}]}{[I^+]} = \frac{[\text{OH}^-]}{K_{\text{IOH}}} = \frac{K_w}{K_{\text{IOH}}} \cdot \frac{1}{[H^+]} = \frac{K_I}{[H^+]}, \quad (3)$$

where K_{IOH} is the ionization constant of the weak indicator base. Expressing the color change as a function of the hydrogen-ion concentration, the ionization product of water K_w is introduced.

The ratio K_w to K_{IOH} at a definite temperature is a constant K_I , which again is called the *indicator constant*. By comparing expressions (2) and (3), it is found that they are completely identical, if we read for

$$\frac{[\text{I}^-]}{[\text{HI}]} = \frac{\text{conc. alkaline form}}{\text{conc. acid form}}$$

and

$$\frac{[\text{IOH}]}{[\text{I}^+]} = \frac{\text{conc. alkaline form}}{\text{conc. acid form}}.$$

Problem.—(a) Plot the change of the ratio of the concentration of the alkaline form to that of the acid form at a pH of 3.3, 3.6, 4.0, 4.5, 5.0, 5.5, 6.0, 6.4 and 6.7, if $p_I = 5$.

(b) The same problem, but plot the logarithm of the above ratio against the indicated pH values.

2. Preparation of Indicator Solutions. *Color-change Interval of Useful Indicators, and Some of Their Properties.*—An enormous number of compounds with indicator properties are found in nature and among products of the laboratory.¹ In this text only a few will be selected, with which most of the colorimetric work can be done and which belong more or less to the ordinary indicators in any laboratory. However, for special research work one should consult the more extensive lists referred to, as for some reason or other indicators not mentioned in the table below may be advantageous for definite cases. Some one-color indicators which can be used in the determination of pH without buffer solutions will be discussed in the next chapter.

A useful concentration of the indicator in the stock solution is of the order of 0.05 to 0.1 per cent. Ordinarily an addition of 0.1 to 0.2 c.c. of such an indicator solution to 10 c.c. of the liquid to be investigated will give satisfactory results. Five of the indicators mentioned in the list behave like weak bases (tropoline 00, methylyellow, methylorange, methylred, and neutral red), the rest like weak acids. The sulfonphthaleins originally

¹ Cf. the lists in W. M. Clark, *The Determination of Hydrogen Ions*, Third Edition, p. 76; also I. M. Kolthoff, *The Use of Indicators*, p. 59.

introduced by Clark and Lubs (1917), later extended by others (especially Barnett Cohen), are all indicators with very sharp color change from yellow to intense red, blue or purple. Bromphenolblue in its transition interval shows a so-called "dichromatism"; the color of the indicator depends upon its concentration and the depth of the layer observed. It appears blue in a thin layer of the solution, and purple when seen through a greater depth. The explanation of this dichromatism is (W. M. Clark) that the alkaline form has two absorption bands, one in the yellow and one in the green; hence the transmitted light is principally red and blue. The transmission coefficient for the red and blue light is different, and therefore the ratio of red and blue observed will vary with the depth of the layer, according to Beer's law:

$$I_{\text{transm.}} = I_{\text{inc}} a^{cd},$$

a is the transmission coefficient, c the indicator concentration, d the length of the layer. In the colorimetric determination of pH this dichromatism of the indicator interferes very much. Often the solution to be examined contains substances which affect the light absorption of the indicator (alcohol, alkaloids; in alcoholic medium the color change is from yellow to blue). Further, the indicator cannot be used in turbid solutions. When a deep layer of the liquid is viewed, only a small amount of light from the bottom of the cell reaches the eye. Most of the light enters the side, is reflected by the particles and has thus traversed a thin layer of liquid, and a blue color is perceived. A comparison of the color with that of the indicator in a clear buffer solution is scarcely possible, for a thin layer of fluid would have to be taken. For the reasons mentioned it is very fortunate that recently W. C. Harden and N. L. Drake² found a good substitute for bromphenolblue in tetrabrom phenol tetrabrom sulfonphthalein. This indicator changes from yellow to blue, has the same color-change interval as bromphenolblue, without showing the dichromatism.

² W. C. Harden and N. L. Drake, *J. Am. Chem. Soc.*, **51**, 562 (1929).

The color change of the sulfonphthaleins may be represented by the following scheme (phenolred):

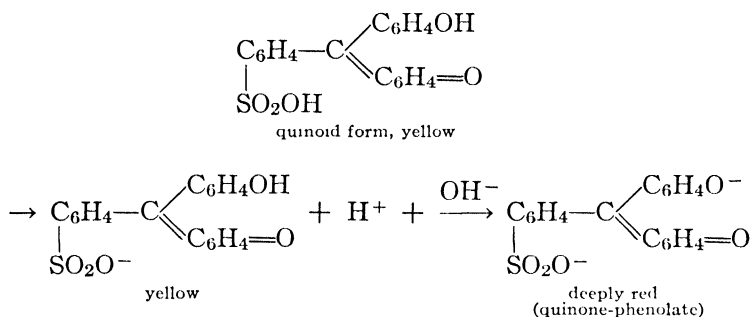

In the table two representatives of the phthaleins have been mentioned: phenolphthalein and thymolphthalein. The latter indicator is only slightly soluble in water, which is an objection to its use in pH determinations. If 0.1 c.c. of a 0.1 per cent indicator solution is added to a buffer solution with a pH of 10 a nice blue color appears. On standing this color fades fairly rapidly on account of the fact that part of the undissociated indicator settles out, and thereby displaces the equilibrium. The color change of the phthaleins can be represented by the following scheme (phenolphthalein):

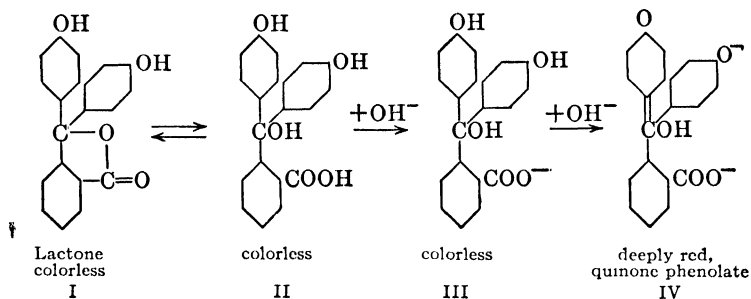

The monovalent ion of phenolphthalein (III) is colorless, the divalent quinone-phenolate ion is deeply red. The alkaline form of the phthaleins is not stable; in alkaline medium it changes

slowly to a colorless trivalent ion derived from the carbinol form:

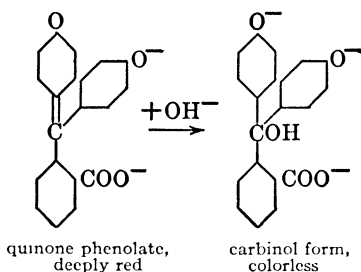

Therefore, alkaline solutions of phenolphthalein and other phthaleins fade on long standing.

In the following table the color change and the pH range of the most important indicators are tabulated. As a rule, water can be used as a solvent, but methyl yellow and the phthaleins have to be dissolved in 90 per cent alcohol. The various sulfophthaleins and methyl red have to be neutralized with sodium hydroxide before they are soluble in water. The former behave as dibasic acids, the indicator properties being determined by the magnitude of the second ionization constant. For most purposes it is sufficient to neutralize the strong sulfonic acid group, but in cases when the pH of practically unbuffered solutions has to be measured more attention should be paid to the proper preparation of the indicator solution. (See p. 52.) One

Indicator	Molecular Weight	C.c. $\frac{1}{2}\%$ NaOH for 100 Mg.
Thymolblue	466	4 3
Tetrabromphenolblue.	986	2 0
Bromphenolblue	669	3 0
Bromcresolgreen.	698	2 9
Methylred.	269	7 4
Chlorphenolred.	423	4 7
Bromphenolred.	512	3 9
Bromthymolblue.	624	3 2
Phenolred	354	5 7
<i>m</i> -Cresolpurple.	382	5 3

COLOR CHANGE AND pH INTERVAL OF THE MOST IMPORTANT INDICATORS

Scientific Name	Trade Name	Solvent	Acid Color	Basic Color	pH Interval
Sodium salt of diphenylaminoazo- <i>p</i> -benzene-sulfonic acid	Tropeoline 00	Water	red	yellow	1.3- 3.0
Thymolsulfonphthalein	Thymolblue	Water (+NaOH)	red	yellow	1.2- 2.8
Dimethylaminoazobenzene	Methylyellow	90 per cent alcohol	red	yellow	2.9- 4.0
Na salt of dimethylaminoazobenzene-sulfonic acid	Methylorange	Water	red	orange-yellow	3.1- 4.4
Tetrabromophenoltetrabromosulfonphthalein	Tetrabromophenolblue	Water (+NaOH)	yellow	blue	3.0- 4.6
Tetrabromophenolsulfonphthalein	Bromphenolblue	Water (+NaOH)	yellow	blue-violet	3.0- 4.6
Tetrabromo- <i>m</i> -cresolsulfonphthalein	Bromcresolgreen	Water (+NaOH)	yellow	blue	3.8- 5.4
Dimethylaminoazobenzene- <i>o</i> -carbonic acid	Methylred	Water (+NaOH)	red	yellow	4.2- 6.3
Dichlorophenolsulfonphthalein	Chlorphenolred	Water (+NaOH)	yellow	red	4.8- 6.4
Dibromophenolsulfonphthalein	Bromphenolred	Water (+NaOH)	yellow	red	5.4- 7.0
Dibromothymolsulfonphthalein	Bromthymolblue	Water (+NaOH)	yellow	blue	6.0- 7.6
Phenolsulfonphthalein	Phenolred	Water (+NaOH)	yellow	red	6.4- 8.0
Dimethyldiaminophenasinchloride	Neutralred	90 per cent alcohol	red	yellow-orange	6.8- 8.0
<i>m</i> -Cresolsulfonphthalein	<i>m</i> -Cresolpurple	Water (+NaOH)	yellow	purple	7.4- 9.0
Thymolsulfonphthalein	Thymolblue	Water (+NaOH)	yellow	blue	8.0- 9.6
Phenolphthalein	90 per cent alcohol	colorless	red violet	8.0- 9.8
Thymolphthalein	90 per cent alcohol	colorless	blue	9.3-10.5
Na salt of <i>p</i> -nitraniline-azosalicylic acid	Alizarine yellow	Water	yellow	violet	10.1-12.0

hundred milligrams of the indicator are rubbed in an agate mortar with the amount of $\frac{1}{20}$ N sodium hydroxide specified in the table below. After the indicator is dissolved, the solution is diluted with water to 100 c.c. (0.1 per cent) or 200 c.c. (0.05 per cent).

3. Influence of the Concentration of the Indicator, the Temperature and the Medium upon the Color-change Interval.—*Concentration of the Indicator.*—We have seen before that the equilibrium of an indicator-acid is represented by:

$$\frac{[I^-]}{[HI]} = \frac{K_I}{[H^+]} \quad (2)$$

If the indicator acid is colorless, and the ion is colored, then the color of the solution at a fixed pH (buffer solution) is determined by:

$$[I^-] = \frac{K_I}{[H^+]}[HI] = K'_I[HI].$$

The amount of the colored form is proportional to that of the undissociated indicator. Therefore, the color of a suitable buffer solution will intensify upon addition of more one-color indicator.

Experiment.—Add to 10 c.c. 0.05 molar borax solution successive amounts of 0.1 per cent phenolphthalein.

The increase of the intensity cannot go on indefinitely, since most indicators are only slightly soluble and $[HI]$ soon approaches its saturation value. If this saturation value corresponds to a concentration s , the maximum color intensity of a (one-color) indicator at a special pH is given by:

$$[I^-] = K'_I s.$$

From the above it is evident that the color-change interval of a one-color indicator depends relatively much upon the concentration of the indicator in the solution.

If we are dealing with two-color indicators, as a matter of fact the effect of the concentration is much less pronounced.

Influence of Temperature.—In the second chapter it has been mentioned that the ionization constant of most ordinary acids and bases changes but slightly with a variation of the temperature. If the same statement holds for indicators the following conclusions can be drawn:

$$\text{Indicator acids: } \frac{[\text{I}^-]}{[\text{HI}]} = \frac{K_{\text{I}}}{[\text{H}^+]} \quad (2)$$

As K_{I} does not change materially with the temperature, the equilibrium does not change at higher temperatures if $[\text{H}^+]$ is kept constant. Therefore the color-change interval of indicator acids is more or less independent of the temperature.

$$\text{Indicator bases: } \frac{[\text{IOH}]}{[\text{I}^+]} = \frac{K_w}{K_{\text{IOH}}} \cdot \frac{1}{[\text{H}^+]} = \frac{K_{\text{I}}}{[\text{H}^+]} \quad (3)$$

K_w increases considerably with increasing temperature, whereas K_{IOH} changes only slightly. Therefore $\frac{K_w}{K_{\text{IOH}}}$ for indicator bases increases rapidly with the temperature, the indicator base will be less sensitive for hydrogen ions at higher temperature, and its color-change interval will be shifted to lower $p\text{H}$ values. Experimentally this has been shown to be the case. Methylorange (indicator base) and bromphenolblue (indicator acid) have the same color-change interval at room temperature. (Cf. preceding table, p. 31.) Whereas the $p\text{H}$ range of the latter indicator is virtually the same at 100° as at 25° , the range of methylorange is shifted from 3.1 to 4.4 at room temperature to 2.5–3.7 at 100° .

Influence of the Medium.—The figures reported in the table (p. 31) hold for water as a solvent. If organic liquids, like ethyl alcohol, methyl alcohol, acetone, etc., with a lower dielectric constant than water, are added to the aqueous solution, the equilibrium conditions are changed. Addition of alcohol to an aqueous solution decreases the ionization constant of weak acids and bases. Consequently indicator acids will become more sensitive to hydrogen ions in the presence of organic solvents and

their color-change interval will be shifted to higher pH values. (Cf. equation (2).)

On the other hand, in mixtures of water with an organic solvent indicator bases will be less sensitive to hydrogen ions than in purely aqueous medium, as the ionization constant of the base decreases more than K_w does. Therefore the color-change interval of indicator bases is shifted to lower pH values in mixtures of water and alcohol.

It should be realized that the equilibrium in a buffer mixture is also changed by the addition of alcohol. If, for example, alcohol is added to a mixture of acetic acid and sodium acetate, the hydrogen-ion concentration decreases, as the ionization constant of acetic acid is diminished. If this change of the constant is the same as that of an indicator acid, the latter will not change its color in the buffer solution upon addition of alcohol. On the other hand, the color of an indicator base will be changed to the alkaline side. This can be easily shown by taking a buffer mixture containing approximately 0.1 N acetic acid and 0.01 N sodium acetate. Tetrabromphenol tetrabromsulfon phthalein assumes an intermediate color in such a solution, which does not change upon the addition of 40 to 50 per cent alcohol. (Bromphenolblue is less suitable for this experiment, as the shade observed changes by addition of alcohol on account of the change of the light absorption. Cf. dichromatism, p. 28.) If methyl-orange is added to the above buffer solution it also assumes an intermediate color, which changes to yellow upon addition of alcohol.

Results of colorimetric pH determinations in mixtures of water and alcohol which were found by comparing the color of an indicator in the mixture with that of the same indicator in aqueous buffer solutions have often been reported in the literature, but data derived in such a way, without considering the effect of the medium, cannot be correct.

CHAPTER III

THE COLORIMETRIC MEASUREMENT OF pH

1. Principle of the Method. Selected Sets of Buffer Mixtures.—If an indicator added to different solutions assumes the same transition shade, the solutions are supposed to have the same pH . (Cf., however, paragraph 5, p. 52.) The same color means the same ratio of acid to basic form ($[HI] : [I^-]$):

$$[H^+] = \frac{[HI]}{[I^-]}K_I.$$

The colorimetric determination of pH is based on the above principle. To the solutions the pH of which has to be determined a measured volume of a suitable indicator is added and the color compared with that of the same indicator in solutions of known pH . The method therefore is a comparison procedure whose accuracy depends primarily upon the correctness of the standard reference solutions. The pH of the latter is determined with the hydrogen electrode. The standardization according to the potentiometric method is therefore the primary procedure upon which the whole colorimetric procedure rests. The standard reference solutions are *buffer-mixtures*, the general theory of which has been discussed in Chapter I (p. 17). Originally S. P. L. Sørensen introduced a complete set of buffer solutions the pH of which he determined very accurately at 18° . In later years various authors published mixtures of other composition, of which those of Clark and Lubs seem to be most popular.

In this text only a few sets of buffer solutions will be selected. A more complete list will be found in W. M. Clark, *The Determination of Hydrogen Ions*; I. M. Kolthoff, *Indicators*, p. 135.

BUFFER SOLUTIONS ACCORDING TO CLARK AND LUBS

The mixtures are very simple to prepare. The original materials may easily be obtained in pure form, and the equal differences in pH value—intervals of 0.2—offer practical advantages.

Primary Solutions	pH Range
0.2 N HCl and 0.2 N KCl	1.0–2.4
0.1 N HCl and 0.1 N K biphthalate	2.2–4.0
0.1 N NaOH and 0.1 N K biphthalate	4.0–6.2
0.1 N NaOH and 0.1 N monopotassium phosphate	6.2–8.0
0.1 N NaOH, 0.1 molar H_3BO_3 and 0.1 N KCl	8.0–10.0

The biphthalate mixtures are not suitable for measurements with methylorange as an indicator. The components in the mixture seem to exert a specific effect upon this indicator, which assumes too acid a color in these buffer solutions. Therefore the pH found in this way is about 0.2 too high.

For this reason mixtures of monopotassium citrate with HCl and NaOH¹ respectively may be valuable under certain conditions¹ and their composition will be described.

Finally, the mixtures of 0.05 molar borax with 0.1 N HCl and 0.1 N NaOH respectively will be tabulated. Originally the pH of these mixtures was measured by S. P. L. Sørensen (1909) at 18°. Walbum has shown later that the pH of these buffer solutions changes relatively much with the temperature. The same is true for the borate buffers of Clark and Lubs.

Purity of Materials to be used in the Preparation of the Buffer Solutions.—0.1 N hydrochloric acid and 0.1 N sodium hydroxide (carbonate free) prepared and standardized according to the usual volumetric procedures.

Potassium Biphthalate.— $M = 204.2$. The C. P. product commercially available is of sufficient purity. It can be recrystallized from water and dried at 110–120°. Its purity has to be checked by a titration with standardized sodium hydroxide, using phenol-

¹ I. M. Kolthoff and J. J. Vleeschhouwer, *Biochem. Z.*, **179**, 410 (1922); **183**, 444 (1922).

phthalein or thymolblue as an indicator. A 0.1 molar solution of the salt is prepared for making the buffer mixtures.

Monopotassium Phosphate.— $M = 136.2$. The commercial salt (C. P.) is recrystallized twice from water and dried at 110 – 120° . Standard solution for the preparation of the buffers is 0.1 molar.

Boric Acid.— $M = 62.0$. A C. P. product is recrystallized from water and dried in the air. Standard solution: 0.1 molar boric acid in 0.1 molar KCl.

Potassium Chloride.— $M = 74.6$. A C. P. product, twice recrystallized from water and dried at 120° .

Monopotassium Citrate.— $C_8H_7O_7K \cdot H_2O$; $M = 248$.

$C_8H_7O_7K$; $M = 230$.

Preparation of the salt: To 420 g. crystallized citric acid (containing 1 mol of water of crystallization) dissolved in 150 c.c. warm water, 138.2 g. water-free potassium carbonate (freshly ignited) are added in small portions. After the evolution of carbon dioxide has ceased the solution is boiled and filtered. The filtrate is stirred and cooled to about 15° . The small crystals are collected by suction, washed with ice-cold water and recrystallized, using an amount of water corresponding to about half the weight of the crystals. The crop of crystals obtained can be dried in a desiccator over deliquescent sodium bromide ($NaBr \cdot 2H_2O$ —sat. sol.) until the weight is constant. The salt contains 1 mole of water, or the crystals may be dried at 80° and obtained in the anhydrous state. They can be kept in the water free state if precautions against the attraction of water from the air are taken. The purity is tested by a titration with sodium hydroxide, using phenolphthalein or thymolblue as an indicator.

Borax.— $Na_2B_4O_7 \cdot 10H_2O$; $M = 381.2$. A C. P. product is recrystallized twice from water and dried in a desiccator over deliquescent sodium bromide ($NaBr \cdot 2H_2O$ —sat. sol.) until constant weight has been reached. Standard solution is 0.05 molar.

BUFFER MIXTURES OF CLARK AND LUBS

0.2 N HCl and 0.2 N KCl at 20°

Composition	pH
47 5 c.c. HCl + 25 c.c. KCl dil. to 100 c.c.	1 0
32 25 c.c. HCl + 25 c.c. KCl dil. to 100 c.c.	1 2
20 75 c.c. HCl + 25 c.c. KCl dil. to 100 c.c.	1 4
13 15 c.c. HCl + 25 c.c. KCl dil. to 100 c.c.	1 6
8 3 c.c. HCl + 25 c.c. KCl dil. to 100 c.c.	1 8
5 3 c.c. HCl + 25 c.c. KCl dil. to 100 c.c.	2 0
3 35 c.c. HCl + 25 c.c. KCl dil. to 100 c.c.	2 2

0 1 molar K-biphthalate + 0 1 N HCl at 20°

46 70 c.c. 0 1 N HCl + 50 c.c. biphthalate to 100 c.c.	2 2
39 60 c.c. 0 1 N HCl + 50 c.c. biphthalate to 100 c.c.	2 4
32 95 c.c. 0 1 N HCl + 50 c.c. biphthalate to 100 c.c.	2 6
26 42 c.c. 0 1 N HCl + 50 c.c. biphthalate to 100 c.c.	2 8
20 32 c.c. 0 1 N HCl + 50 c.c. biphthalate to 100 c.c.	3 0
14 70 c.c. 0 1 N HCl + 50 c.c. biphthalate to 100 c.c.	3 2
9 90 c.c. 0 1 N HCl + 50 c.c. biphthalate to 100 c.c.	3 4
5 97 c.c. 0 1 N HCl + 50 c.c. biphthalate to 100 c.c.	3 6
2 63 c.c. 0 1 N HCl + 50 c.c. biphthalate to 100 c.c.	3 8

0 1 molar K-biphthalate + 0 1 N NaOH at 20°

0 40 c.c. 0 1 N NaOH + 50 c.c. biphthalate to 100 c.c.	4 0
3 70 c.c. 0 1 N NaOH + 50 c.c. biphthalate to 100 c.c.	4 2
7 50 c.c. 0 1 N NaOH + 50 c.c. biphthalate to 100 c.c.	4 4
12 15 c.c. 0 1 N NaOH + 50 c.c. biphthalate to 100 c.c.	4 6
17 70 c.c. 0 1 N NaOH + 50 c.c. biphthalate to 100 c.c.	4 8
23 85 c.c. 0 1 N NaOH + 50 c.c. biphthalate to 100 c.c.	5 0
29 95 c.c. 0 1 N NaOH + 50 c.c. biphthalate to 100 c.c.	5 2
35 45 c.c. 0 1 N NaOH + 50 c.c. biphthalate to 100 c.c.	5 4
39 85 c.c. 0 1 N NaOH + 50 c.c. biphthalate to 100 c.c.	5 6
43 00 c.c. 0 1 N NaOH + 50 c.c. biphthalate to 100 c.c.	5 8
45 45 c.c. 0 1 N NaOH + 50 c.c. biphthalate to 100 c.c.	6 0

0 1 molar monopotassium phosphate + 0 1 N NaOH at 20°

5 70 c.c. 0 1 N NaOH + 50 c.c. phosphate to 100 c.c.	6 0
8 60 c.c. 0 1 N NaOH + 50 c.c. phosphate to 100 c.c.	6.2
12 60 c.c. 0 1 N NaOH + 50 c.c. phosphate to 100 c.c.	6 4
17 80 c.c. 0 1 N NaOH + 50 c.c. phosphate to 100 c.c.	6 6
23 45 c.c. 0 1 N NaOH + 50 c.c. phosphate to 100 c.c.	6.8
29 63 c.c. 0 1 N NaOH + 50 c.c. phosphate to 100 c.c.	7.0
35 00 c.c. 0 1 N NaOH + 50 c.c. phosphate to 100 c.c.	7.2
39 50 c.c. 0 1 N NaOH + 50 c.c. phosphate to 100 c.c.	7.4
42 80 c.c. 0 1 N NaOH + 50 c.c. phosphate to 100 c.c.	7.6
45 20 c.c. 0 1 N NaOH + 50 c.c. phosphate to 100 c.c.	7.8
46 80 c.c. 0 1 N NaOH + 50 c.c. phosphate to 100 c.c.	8.0

BUFFER MIXTURES OF CLARK AND LUBS—*Continued*0.1 molar H_3BO_3 in 0.1 molar KCl + 0.1 N NaOH at 20°

Composition	pH
2 61 c.c. 0.1 N NaOH + 50 c.c. boric acid to 100 c.c.	7.8
3 97 c.c. 0.1 N NaOH + 50 c.c. boric acid to 100 c.c.	8.0
5 90 c.c. 0.1 N NaOH + 50 c.c. boric acid to 100 c.c.	8.2
8 50 c.c. 0.1 N NaOH + 50 c.c. boric acid to 100 c.c.	8.4
12 00 c.c. 0.1 N NaOH + 50 c.c. boric acid to 100 c.c.	8.6
16 30 c.c. 0.1 N NaOH + 50 c.c. boric acid to 100 c.c.	8.8
21 30 c.c. 0.1 N NaOH + 50 c.c. boric acid to 100 c.c.	9.0
26 70 c.c. 0.1 N NaOH + 50 c.c. boric acid to 100 c.c.	9.2
32 00 c.c. 0.1 N NaOH + 50 c.c. boric acid to 100 c.c.	9.4
36 85 c.c. 0.1 N NaOH + 50 c.c. boric acid to 100 c.c.	9.6
40 80 c.c. 0.1 N NaOH + 50 c.c. boric acid to 100 c.c.	9.8
43 90 c.c. 0.1 N NaOH + 50 c.c. boric acid to 100 c.c.	10.0

CITRATE BUFFERS OF KOLTHOFF AND VLEESCHOUWER

0.1 molar monopotassium citrate and 0.1 N HCl at 18°

(Add tiny crystal of thymol against growth of molds)

Composition	pH
49 7 c.c. 0.1 N HCl + 50 c.c. citrate to 100 c.c.	2.2
43 4 c.c. 0.1 N HCl + 50 c.c. citrate to 100 c.c.	2.4
36 8 c.c. 0.1 N HCl + 50 c.c. citrate to 100 c.c.	2.6
30 2 c.c. 0.1 N HCl + 50 c.c. citrate to 100 c.c.	2.8
23 6 c.c. 0.1 N HCl + 50 c.c. citrate to 100 c.c.	3.0
17 2 c.c. 0.1 N HCl + 50 c.c. citrate to 100 c.c.	3.2
10 7 c.c. 0.1 N HCl + 50 c.c. citrate to 100 c.c.	3.4
4 2 c.c. 0.1 N HCl + 50 c.c. citrate to 100 c.c.	3.6

0.1 molar monopotassium citrate + 0.1 N NaOH at 18°

(Add tiny crystal of thymol against growth of molds)

2 0 c.c. 0.1 N NaOH + 50 c.c. citrate to 100 c.c.	3.8
9 0 c.c. 0.1 N NaOH + 50 c.c. citrate to 100 c.c.	4.0
16 3 c.c. 0.1 N NaOH + 50 c.c. citrate to 100 c.c.	4.2
23 7 c.c. 0.1 N NaOH + 50 c.c. citrate to 100 c.c.	4.4
31 5 c.c. 0.1 N NaOH + 50 c.c. citrate to 100 c.c.	4.6
39 2 c.c. 0.1 N NaOH + 50 c.c. citrate to 100 c.c.	4.8
46 7 c.c. 0.1 N NaOH + 50 c.c. citrate to 100 c.c.	5.0
54 2 c.c. 0.1 N NaOH + 50 c.c. citrate	5.2
61 0 c.c. 0.1 N NaOH + 50 c.c. citrate	5.4
68 0 c.c. 0.1 N NaOH + 50 c.c. citrate	5.6
74 4 c.c. 0.1 N NaOH + 50 c.c. citrate	5.8
81.2 c.c. 0.1 N NaOH + 50 c.c. citrate	6.0

BORATE MIXTURES OF SÖRENSEN

0.05 molar borax + 0.1 N HCl

Composition		Sorensen, 18°	Walbum, pH at		
C.c. Borax	C.c. HCl		10°	40°	70°
5.25	4.75	7.62	7.64	7.55	7.47
5.5	4.5	7.94	7.96	7.86	7.76
5.75	4.25	8.14	8.17	8.06	7.95
6.0	4.0	8.29	8.32	8.19	8.08
6.5	3.5	8.51	8.54	8.40	8.26
7.0	3.0	8.68	8.72	8.56	8.40
7.5	2.5	8.80	8.84	8.67	8.50
8.0	2.0	8.91	8.96	8.77	8.59
8.5	1.5	9.01	9.06	8.86	8.67
9.0	1.0	9.09	9.14	8.94	8.74
9.5	0.5	9.17	9.22	9.01	8.80
10.0	0.0	9.24	9.30	9.08	8.86

0.05 molar borax + 0.1 N NaOH

10.0	0.0	9.24	9.30	9.08	8.86
9.0	1.0	9.36	9.42	9.18	8.94
8.0	2.0	9.50	9.57	9.30	9.02
7.0	3.0	9.68	9.76	9.44	9.12
6.0	4.0	9.97	10.06	9.67	9.28

A change of temperature affects the pH of buffer solutions only slightly, and for practical purposes it can be assumed that the data reported hold for temperatures between 15° and 30°. The only exception is formed by mixtures of boric acid and sodium hydroxide, the pH of which decreases markedly with increase in temperature. (Cf. last two tables.) This change is caused by a shift of the equilibrium between boric acid and its polymolecular complexes.

In the general discussion of buffer solutions (Chapter I, p. 22), it has been mentioned that one of their characteristics is that they are very insensitive to dilution with water. For this reason it is not at all necessary to prepare the buffer mixtures in a volumetric

flask; the important thing is the ratio of the acid and basic component. Therefore in the case of the monopotassium phosphate-sodium hydroxide mixtures, for example, both solutions have to be measured out exactly. The phosphate is pipetted into the flask, in which the mixture is kept, the sodium-hydroxide is added from a burette, and the volume is made up to 100 c.c. by adding the required volume of water from a graduate. How slightly the pH of a phosphate mixture is affected by dilution with water is shown by the following figures:² Clark and Lubs' buffer $pH = 7.00$; diluted twice $pH = 7.05$; diluted 5 times $pH = 7.13$; diluted 10 times $pH = 7.17$; diluted 20 times $pH = 7.18$.

2. The Colorimetric Measurement with Buffer Solutions.—

In the determination of the pH of an unknown a suitable indicator has to be found in the first place. Only indicators which show an intermediate color between the extreme acid and alkaline one can be used. Beginners often overlook this elementary rule and thereby make the most serious mistakes. If the approximate value of the pH of the solution to be examined is not known, the order of its magnitude has to be approximated, in order to select the correct indicator. A few simple tests as a rule will supply the required information. To a small fraction of the solution a drop of phenolphthalein is added. If the indicator is colorless it means that the pH of the solution is smaller than 8.0. (Cf. pH interval of indicators, p. 31.) Another test is made with methylorange or bromphenolblue. If one of these indicators assumes the alkaline color, it means that the pH is larger than 4.5. Therefore the pH of the unknown lies between 4.5 and 8.0. A few more tests with methylred (pH interval 4.4–6.0); bromthymolblue (6.0–7.6) and phenolred (6.8–8.0) will show the approximate value of pH and indicate which indicator(s) should be used in the determination. Instead of testing small amounts of the liquid with indicator solutions, indicator papers (phenolphthalein or thymolblue paper, litmus, congo red, etc.) as a rule can be used by application of the spot method.

² I. M. Kolthoff, *Biochem. Z.*, **195**, 239 (1928), where a more general discussion is given.

As soon as the approximate value of pH is known, 3 or 5 or 10 c.c. (dependent upon the amount of liquid available) are measured out by means of a graduate and transferred into a test tube of Pyrex glass or any other resistant glass (diameter about 1.5 cm., length about 15 cm.). Soft glass should not be used as it may give off alkali. A measured amount of the indicator solution is added carefully from a pipette of 1 c.c., which is graduated in 0.01 c.c. As a rule 0.1 to 0.2 c.c. of 0.05 per cent indicator solution to 10 c.c. liquid will be a proper amount. Then some buffer solutions (4 to 6) the pH of which overlaps that of the unknown are taken and treated in exactly the same way. (All test tubes should have the same inner size.) Especially if one-color indicators are used, it is extremely important to add to the unknown and the buffer solutions exactly the same amount of indicator.

The best way of judging the color is to observe, against a white background, the light transmitted through the whole length of the tube. A suitable colorimeter can be used as well, though it is not necessary at all in routine work. Enough reference solutions must be taken so that the color of the unknown falls between two of the series and not beyond. If buffer solutions are used with pH differences of 0.2, respectively, the pH of the unknown can be approximated to within 0.1 very easily, and with some practice to 0.05. As a rule a closer approximation of pH according to the colorimetric method has no exact meaning, on account of the uncertainty in the results caused by some factors which will be discussed later. However, with buffer solutions that differ by 0.1 pH unit or less, the *experimental* error can be reduced to 0.01 to 0.02 in pH . If possible, indicators should be selected the indicator exponents ($-\log K_1$) of which are of the same order of magnitude as the pH of the unknown. At this range, the color of the indicator is most sensitive for a small change in pH . If the pH lies nearer the end of the transition interval of the indicator, the color changes in a less sensitive way with a small variation in pH .

3. The Colorimetric Measurement without Buffer Solutions.—In Chapter II it was found that the relation between the color of an indicator and the hydrogen-ion concentration of a solution is given by the expression:

$$[\text{H}^+] = \frac{[\text{HI}]}{[\text{I}^-]} K_I \quad (1)$$

or

$$p\text{H} = \log \frac{[\text{I}^-]}{[\text{HI}]} + pK_I. \quad (2)$$

K_I is a constant for each indicator. If the ratio of the concentration of the acid to the alkaline form of the indicator in the unknown can be determined in an experimental way, the $p\text{H}$ can be computed according to equation (2). Therefore on this basis it is possible to derive $p\text{H}$ without the use of buffer solutions. From the experimental point of view it is desirable to distinguish between the use of one- and two-color indicators.

(a) *Two-color Indicators.*—L. J. Gillespie³ proposed the following simple technique. He sets up in a comparator (*cf.* Fig. 3, p. 52) two tubes, one of which contains some drops (let us say a drops) of a given indicator fully transformed into the acid form and the other of which contains $(10 - a)$ drops of the indicator fully transformed into the alkaline form. By changing a from 1 to 9, pairs of tubes are obtained containing $[\text{HI}]$ and $[\text{I}^-]$ in a ratio changing from $1/9$ to $9/1$. If the two comparison solutions and the tested solution, to which 10 drops of the same indicator are added, are kept at the same volume and the view is through equal depths of each, a simple comparison of the unknown with various pairs of acid and basic solutions of the indicator will show the ratio of acid and basic form of the latter in the tested solution. Instead of working with drops it is preferable to measure the various amounts of indicator (0.01–0.02 per cent) by means of a

³ L. J. Gillespie, *J. Am. Chem. Soc.*, **42**, 742 (1920); *Soil Sc.*, **9**, 115 (1920).

pipette of 1 c.c. graduated in 0.01 c.c. In order to increase the accuracy a bicolorimeter can be used instead of the pairs of test tubes. The principle of the bicolorimeter is shown in Fig. 1.

A and C are fixed, B moves along a graduated scale which is read by a pointer on B . The pointer may move over 100 scale divisions. The acidified indicator solution of suitable strength may be placed in B ; the alkaline solution of equal strength in C . The solution to be examined is placed in E and enough indicator

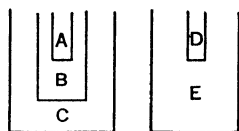

FIG. 1.—Gillespie's bicolorimeter.

is added to make the concentration the same as in B and C . B is then moved until the colors are matched, and the scale reading then gives the ratio of the acid to the alkaline color. The solution to be examined, if colored or turbid, is received in the small tube A . In this case an amount of water equal to that of the

solution is placed in D (compare measurement of pH in colored solutions, p. 50). Another principle which has proved to be useful in the construction of a bicolorimeter is that of two wedges of equal size, cemented or fused together. One wedge is filled with the completely acid solution of the indicator, the other with the alkaline solution of the same indicator concentration. The two wedges are placed in such a position that they can move up and down, so that various ratios of the acid and alkaline form can be observed by a screen, which makes it possible to view small sharply defined segments of the liquid at a time. On one side of the simple apparatus is placed a scale, on which the ratio of acid to basic form in any position can be read. The liquid to be tested is put into a cylinder with plane walls or into a cell, and treated with enough indicator to give a depth of color equal to that in the double-wedge apparatus. The colors are matched against a white background. Other methods, more or less useful in routine work, where the transition colors of various indicators are imitated by suitable mixtures of stable inorganic colored salt solutions or colored glass disks, have been proposed in the literature. For details the reader is referred to special text-books on

pH determinations. (See Preface; Clark; Kolthoff; Britton.) Finally, it should be mentioned that the ratio of the acid to basic form can be determined very accurately by spectrophotometric measurements. The latter method, though very valuable for special research, has not been developed in such a simple form as to justify its use in ordinary practical work. Besides, it should always be remembered that even if the colorimetric method could be developed to a great perfection, it would still be less satisfactory than the potentiometric method, on account of uncertainties inherent in the principle of the procedure itself. (Cf. paragraph, p. 52.)

For the preparation of the indicator in the completely acid form, solutions of bromcresolgreen, chlorphenolred, methylred, bromthymolblue, phenolred, or cresolred of the proper strength in water can be acidified with acetic acid so that the concentration of the latter is about 0.1 N. They are completely present in the alkaline form, if so much sodium carbonate is added to the aqueous solution that the concentration of the salt is about 0.01 to 0.02 N. Methylorange and bromphenolblue in about 0.01 N hydrochloric acid are completely transformed into the acid form, whereas in 0.01 N sodium carbonate or bicarbonate they are present in the alkaline form. Thymolblue has two color-change intervals, one at the acid range from red to yellow between *pH* 1.2 and 2.8, and one at the alkaline range between 8.0 and 9.6 from yellow to blue. For measurements of *pH* in the neighborhood of 2 the acid form of the indicator is obtained by acidifying the solution with so much hydrochloric acid that the concentration of the latter is about 0.25 N. This solution has to be freshly prepared before the experiment. The indicator is completely present in the yellow form in a solution of about 1 per cent monopotassium phosphate. In making measurements at a *pH* around 9.0 the latter solution is the acid form of the indicator, whereas it is completely present in the alkaline form (blue color) in about 0.05 N sodium carbonate.

In the beginning of this paragraph it was mentioned that if the ratio of the acid and the alkaline form of the indicator in the

unknown has been determined, pH can be calculated if pK_I is known:

$$pH = \log \frac{[I^-]}{[HI]} + pK_I.$$

In the following table the most reliable figures on pK_I are tabulated.⁴ The constants given hold for a temperature of 20°; where necessary, the influence of the temperature upon the magnitude of the constant is indicated. It will be shown later (p. 55) that the indicator constants are also a function of the electrolyte content of the solution. The values given hold where the ionic strength of the medium is zero, a case which is rarely

pK_I VALUES OF TWO-COLOR INDICATORS AT 20° AT VARIOUS IONIC STRENGTHS

Indicator	pK_I at Ionic Strength Zero; at Various Temperatures	pK_I at Ionic Strength of			
		0.01	0.05	0.1	0.5
Thymolblue . . . (acid range)	1.65 (15–30°)	.	1.65	1.65	1.65
Methylorange..	3.46–0.014($t-20^\circ$)	3.46	3.46	3.46	3.46
Bromphenolblue..	4.10 (15–20°)	4.06	4.00	3.85	3.75(KCl)
Bromcresolgreen...	4.90 (15–30°)	4.80	4.70	4.66	4.50(KCl) 4.42(NaCl)
Methylred. . .	5.00–0.006($t-20^\circ$)	5.00	5.00	5.00	5.00
Chlorphenolred. . .	6.25–0.005($t-20^\circ$)	6.15	6.05	6.00	5.9 (KCl) 5.85(NaCl)
Bromcresolpurple .	6.40–0.005($t-20^\circ$)	6.28	6.21	6.12	5.9 (KCl) 5.8 (NaCl)
Bromthymolblue	7.30 (15–30°)	7.19	7.13	7.10	6.9 (KCl) 6.8 (NaCl)
Phenolred. . .	8.00–0.007($t-20^\circ$)	7.92	7.84	7.81	7.6 (KCl) 7.5 (NaCl)
Thymolblue . . .	9.20 (15–30°)	9.01	8.95	8.90	

Methylorange and methylred distinguish themselves favorably by the fact that their constant is not affected by the presence of electrolytes up to an ionic strength of 0.5.

⁴ Cf. I. M. Kolthoff, J. Physic. Chem., **34**, 1466 (1930).

approached in practical work. Therefore pK values are also given at various ionic strengths of potassium and sodium salts. If the salt content and the kind of salt in the solution tested are approximately known, the proper indicator exponent pK_I can be selected from the table.

(b) *One-color Indicators*.—The experimental procedure may be simplified by the use of one-color indicators, one form of which is colorless and the other one is colored. It has been developed by Michaelis and co-workers (1920), and later extended by other workers. If, for example, 10 c.c. of a tested solution containing 1 c.c. of indicator matches the color of 10 c.c. of an alkaline solution containing 0.5 c.c. of the same solution of the indicator in the alkaline form, it is easily seen that in the tested solution 50 per cent of the indicator is transformed into the alkaline form, and 50 per cent is present in the acid form; hence:

$$pH = \log \frac{[I^-]}{[HI]} + pK_I = pK_I.$$

Quite generally, if we determine the concentration c of the alkaline form, and the total concentration of the indicator in the tested solution is a , then:

$$pH = \log \frac{c}{a - c} + pK_I.$$

The determinations can be made with any ordinary colorimeter or even with test tubes of equal bore. In the latter case to a proper volume of the solution to be tested (e.g., 10 c.c.) a measured volume (preferably 1 c.c.) of the proper indicator solution is added from a pipette. To a second test tube containing approximately 9 c.c. 0.1 N sodium carbonate such a volume of indicator solution (accurately measured from a pipette of 1 c.c. or a microburette divided in 0.01 c.c.) is added, that the color developed approximately matches that of the first tube. The volume of the second tube is now made up to the volume of the first tube. Other trials with more or less indicator are made until a complete color match is obtained. This amount of indicator then corre-

sponds to the fraction of the 1 c.c. added to the solution tested which has been transformed into the alkaline tautomer. If only a small fraction (5 to 10 per cent) is transformed into the alkaline form, the accuracy of the procedure can be somewhat increased by making the color match with an indicator solution ten times more dilute than the standard solution.

In the following table the pK_I values of suitable one-color indicators are tabulated. Again the influence of the ionic strength and the temperature has been indicated. The dinitrophenols and *p*-nitrophenol can be prepared in a strength of 0.04 per cent in water; *m*-nitrophenol is less colored in alkaline medium and is better used as 0.1 per cent solution. The nitrophenols are colorless in acid medium, and yellow in the alkaline form. The methoxytriphenylcarbinols can be used in 0.02 per cent solution in 60 per cent alcohol; they are weak bases, the cation of which is red, and the alkaline form colorless. Quinaldinred has proved to be useful in physiological work; a 0.03 per cent solution in 50 per cent alcohol can be kept for a long time. In acid medium the indicator is colorless, in alkaline medium red. Pinachrom (M) (Tables of Schulz No. 611) is *p*-ethoxyquinaldin-*p*-ethoxyquinolin ethylcyanine; it behaves like a base, which is colorless in acid medium and red in alkaline medium. It is very slightly soluble in water, but is soluble in hydrochloric acid, forming a colorless solution. The stock solution can be prepared by neutralizing the basic group with hydrochloric acid; (mol. weight = 518): 100 mg. indicator is dissolved in 40 c.c. of alcohol, 1.9 c.c. of 0.1 N hydrochloric acid is added and the solution made up to a volume of 100 c.c. with water. The solution has a weak violet color and is kept in a Pyrex bottle. The pinachrom does not change its color instantaneously; after addition of the indicator to the solution to be tested one has to wait at least two minutes before the comparison is made. The alkaline solutions of the indicator (for comparison) cannot be kept a long time, as they are unstable. The free red base is very slightly soluble in water and precipitates after standing for a short time.

The alkaline solutions for comparison are made up in about

0.01 N sodium carbonate solution by *carefully mixing* a known amount of the indicator with the carbonate; shaking of the tube should be avoided. The solutions for comparison can be kept for one hour but not longer.

For the measurements 1 c.c. of 0.01 per cent indicator solution (see above) is added to 10 c.c. of the solution to be tested. The color is compared with that of standards containing known amounts of 0.002 per cent indicator in 0.01 N sodium carbonate.⁵

pK_I VALUES OF ONE-COLOR INDICATORS AT 20° AND VARIOUS IONIC STRENGTHS

Indicator	pK_I at Ionic Strength Zero; at 20°	pK_I at Ionic Strength of			
		0 01	0 05	0 1	0 5
2, 4, 2', 4', 2''-Pentamethoxytriphenylcarbinol *	$1.86 + 0.008(t - 20^\circ)$		1.86	1.86	
Quinaldine red	$2.63 - 0.007(t - 20^\circ)$	2.80		2.90	3.10
2, 4, 2', 4', 2'', 4''-Hexamethoxytriphenylcarbinol	$3.32 + 0.007(t - 20^\circ)$		3.32	3.32	(KCl)
β -Dinitrophenol (1-oxy-2, 6-dinitrobenzene)	$3.70 - 0.006(t - 20^\circ)$		3.95	3.90	3.80(KCl)
α -Dinitrophenol (1-oxy-2, 3-dinitrobenzene)	$4.10 - 0.006(t - 20^\circ)$		3.95	3.90	3.80(KCl)
γ -Dinitrophenol (1-oxy-2, 5-dinitrobenzene)	$5.20 - 0.0045(t - 20^\circ)$		5.12	5.10	5.00(NaCl)
2, 4, 6, 2', 4', 2'', 4''-Heptamethoxytriphenylcarbinol			5.90	5.90	
Pinachrom.	$7.34 - 0.013(t - 20^\circ)$	7.34		7.47	7.64(KCl)
<i>p</i> -Nitrophenol	$(7.00 \text{ to } 7.15) - 0.011(t - 20^\circ)$				
<i>m</i> -Nitrophenol	$8.35 - 0.01(t - 20^\circ)$		8.30	8.25	8.15(NaCl)

* Properties of the methoxytriphenylcarbinols, cf. H. Lund, J. Am. Chem. Soc., 49, 1346 (1927); I. M. Kolthoff, J. Am. Chem. Soc., 49, 1218 (1927).

⁵Cf. I. M. Kolthoff, J. Am. Chem. Soc., 50, 1604 (1928).

Phenolphthalein is also a one-color indicator, the monovalent anion and the undissociated form of which are colorless, whereas the divalent ion is intense red-violet. The simple computation of pH from the ratio of the concentration of the colored to the uncolored form cannot be applied here, on account of the fact that the first and second step of the dissociation of the phenolphthalein overlap each other. Therefore Michaelis and Gyemant⁶ give an empirical table for this indicator, which will be given below, though it must be mentioned that the author's results do not agree exactly with those reported.⁷ The phenolphthalein is used as a 0.04 per cent solution in 30 per cent alcohol. The alkaline solution (in 0.1 N sodium carbonate or 0.01 N sodium hydroxide) is not stable and has to be freshly prepared before the experiment. The value c in the table represents the colored fraction of the indicator, considering that the concentration of the uncolored part is $(1 - c)$.

TABLE FOR PHENOLPHTHALEIN AT 20° AND IONIC STRENGTH OF 0.1

c	pH	c	pH	c	pH
0 010	8 47	0 21	9 22	0 65	10 02
0 030	8 62	0 34	9 42	0 75	10 22
0 069	8 82	0 45	9 62	(0 845)	(10 42)
0 120	9 02	0 55	9 82		

Temperature correction: 0 0110 ($t - 20^\circ$).

4. Colored Solutions: Compensation for Own Color.—If the color of the solution to be tested is very intense the colorimetric method no longer will yield satisfactory results, and even if the solution is only slightly colored, the direct method of matching its color by the addition of indicator to a clear standard buffer solution will no longer be applicable. However, the interference can be overcome in a simple way. Suppose the buffer solution

⁶ L. Michaelis and A. Gyemant, *Biochem. Z.*, **109**, 165 (1920),

⁷ Cf. I. M. Kolthoff, *Indicators*, p. 165.

and the colored solution have the same pH . Upon addition of a suitable indicator they will not show the same color, as the unknown already contains some colored component. If the color effects are additive then the latter color of the buffer and the unknown will be the same if the latter is compared in transmitted light, with the same depth of colored solution (without indicator) placed above the buffer solution containing the indicator. In this manner the color of the solution is eliminated. This is the principle of the *Walpole*⁸ comparator and the so-called *block-comparator*.

Walpole Comparator (Fig. 2).—The interior is painted black. The various liquids are placed in the four plane-bottom cells to the same depth in each. Light is made to pass up through these solutions either by means of a reflecting surface or by some suitable direct illumination placed underneath the apparatus. The cell containing the buffer solution and indicator is replaced by others until a perfect match is obtained.

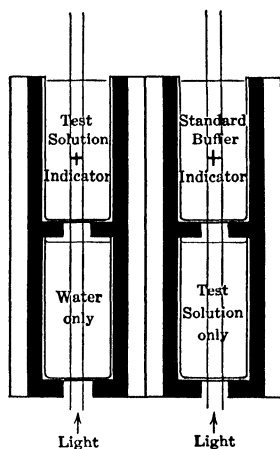

FIG. 2.—Walpole comparator.

Block Comparator (Hurwitz, Meyer and Ostenberg).⁹—This simple instrument should be available to anyone experimenting on the pH field. Six deep holes just large enough to hold the test tubes are bored parallel to one another in pairs in a block of wood. Perpendicular to these holes and running through each pair are bored smaller holes through which the test tubes may be viewed. All the holes are painted a non-reflecting black. The center pair of test tubes holds, first, the solution to be tested plus the indicator and, second, a water blank. At either side are placed the buffer solutions plus indicator, each backed by a sample of the colored solution under test.

⁸ Walpole, *Biochem. J.*, **24**, 40 (1910).

⁹ *Proc. Soc. Exp. Biol. and Med.*, **13**, 24 (1915).

If the Gillespie method (*cf.* p. 43) is applied to colored solutions it is necessary to have three pairs of three holes (one after the other) in order to compensate for the color.

The comparator device can also be used for slightly turbid solutions, though relatively thin layers of liquid should be observed.

5. Sources of Error in the Colorimetric Method. (a) *Slightly Buffered Solutions.*—Acid-base indicators behave as we have seen

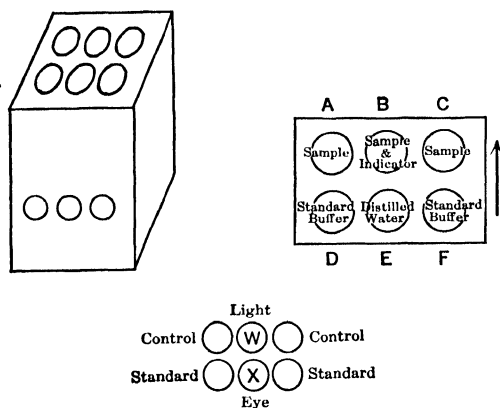

FIG. 3.—Comparator.

like substances with a weak acidic or basic character, and therefore they will have a tendency to change the pH when added to a slightly buffered or unbuffered solution. As the molecular concentration of indicators in colorimetric work is of the order of 10^{-5} to 10^{-6} , the *acid* or *base* error of the indicator will only be noticeable in solutions with extremely slight buffer action. However, in practical work one often meets with those cases, for example, in the measurement of pH of pure water or of solutions of neutral salts in pure water, of extremely weak acids and bases in water, etc. Suppose one adds to 10 c.c. of pure water ($pH = 7.0$ at 24°) 0.1 c.c. of a 0.04 per cent solution of methylred. The latter dye has an indicator constant of 10^{-5} , and it is a simple matter to calculate that the addition of the above trace of methyl-

red will change the pH of water from 7.0 to about 5.0. Actually this can be shown to be the case; ¹⁰ the author noticed a color corresponding to a pH of 5.1 in a buffer mixture.

It will be easily understood that in the measurement of pH in slightly buffered solutions reliable results will be obtained only if the indicator solution added has the same pH as the unknown. E. H. Fawcett and S. F. Acree ¹¹ call these indicator solutions *adjusted* or *isohydric*.

Now, of course, the problem arises: If the pH of the solution tested is unknown, how then is it possible to select an isohydric indicator solution? The question fortunately can be answered in an empirical way. Theoretically it has been shown ¹² and practically verified that the pH measured in an unbuffered solution is independent of the amount of indicator added, *if the latter is isohydric*. If the indicator solution added has a more acid reaction than the solution tested, decreasing pH values will be found with increasing amount of indicator. On the other hand if the indicator solution is more alkaline, the pH found will increase with increasing amount of indicator. An intelligent application of this simple rule enables us to solve the hard problem of measuring the pH of unbuffered solutions. Let us consider the hardest problem, which is the measurement of pH of pure, carbon dioxide-free water. (Naturally, the experiments have to be carried out under such conditions that no carbon dioxide from the air can enter during the measurements.) By preliminary experiments it is found that the pH of pure water is in the vicinity of 7 (6.5 to 7.5), therefore an indicator like bromthymolblue with a color-change interval in this neighborhood has to be used. For ordinary work the solution of this indicator is prepared by neutralizing the strong sulfonic group with sodium hydroxide (*cf.* p. 30); the sulfonphthalein, however, exerts its indicator properties in neutralizing the monovalent anion HI^-

¹⁰ I. M. Kolthoff, *Biochem. Z.*, **168**, 110 (1928).

¹¹ E. H. Fawcett and S. F. Acree, *J. Bact.*, **17**, 163 (1929); *Ind. Eng. Chem. Anal. Ed.*, **2**, 78 (1930).

¹² *Cf.* I. M. Kolthoff and T. Kameda, *J. Am. Chem. Soc.*, **53**, 825 (1931).

which is yellow, to the divalent anion I^- (blue). A solution of the monovalent salt has a pH smaller than 7.00, and therefore if increasing amounts of this solution are added to pure water, a decreasing pH will be observed. This could be confirmed in an experimental way. A solution of bromthymolblue was prepared, containing 0.1 per cent of indicator, and the mono- and divalent anion in a ratio of 96 : 4. Upon addition of 0.1 c.c. of this indicator solution to 15 c.c. of pure water a pH of 6.37 was measured; with 0.3 c.c. a pH of 6.25; with 0.5 cc., of 5.95. On the other hand, if an indicator solution of the same strength was prepared, containing the mono- and divalent anion in a ratio of 4 : 96, a pH of 7.68 was measured upon addition of 0.1 c.c. of indicator to 15 c.c. of water; of 7.80 with 0.3 c.c. of indicator; of 8.00 with 0.5 c.c. Empirically, it was found that an indicator solution, containing the mono- and divalent anion in a ratio of 65 : 35 was isohydric with pure water. With 0.1, 0.3 and 0.5 c.c. of this indicator solution, respectively, a pH between 6.78 and 6.76 was measured. (On account of the difference in electrolyte content between the water and the buffer solution used for comparison, the experimental value had to be corrected for the salt influence, and yielded then a pH of 7.03 to 7.01; *cf.* sub. b. p. 55.)

Quite generally the problem of measuring the pH of unbuffered, or slightly buffered, solutions can be solved in a similar way. First of all the approximate pH of the solution to be tested is determined, so that the proper indicator or indicators can be selected. Two solutions of the indicator are prepared, one containing it in the acid form (in case of sulfonphthaleins the monovalent salt) and the other containing it in the alkaline form. A mixture containing both forms in equal portions is prepared, and measurements are made with successive amounts of indicator. If the pH increases with increasing amounts of indicator, the mixture has too alkaline a reaction, and another has to be prepared containing the acid and basic form, e.g., in a ratio of 75 : 25. If the indicator mixture 1 : 1 was too acid, the two forms have to be mixed in a ratio of 25 : 75 and the measurements repeated.

Only the isohydric mixture yields results which do not change with the amount of indicator added.

It should be remembered that these indicator mixtures are not quite stable after standing; they should be freshly prepared before the experiments.

(b) *The Salt Effect*.—In the beginning of this chapter it was stated that the colorimetric measurement of pH is based upon the fact that if an indicator in two solutions assumes the same color the pH of both liquids is the same. Strictly speaking, this statement is not quite correct on account of the fact that in all our quantitative expressions of the equilibrium we have written *concentrations* instead of *activities* of the components. In the first chapter, paragraph 2, it was mentioned that an equilibrium constant is determined by the activity of the reacting components and not by their concentrations. Therefore if we express the ionization constant of an acid like an indicator acid, K_I in the expression:

$$K_I = \frac{[aH^+][aI^-]}{[aHI]} \quad (3)$$

will be a true constant (a denotes the activity of the various components); its magnitude will be independent of the presence of salts.

On the other hand, K_I in the expression:

$$K_I = \frac{[H^+][I^-]}{[HI]}$$

will not be constant at different electrolyte contents of the solution, as the activity coefficient of the various components changes with the ionic strength.

The potentiometric measurements with the hydrogen and quinhydrone electrodes give us the value of the activity of the hydrogen ions $[aH^+]$, and in colorimetric work it is desirable to find the same expression. At a certain activity of the hydrogen

15628

ions the equilibrium in an indicator solution is determined by the expression (*cf.* equation 3):

$$\frac{[aHI]}{[aI^-]} = \frac{[aH^+]}{K_I} \quad (4)$$

If f_0 represents the activity coefficient of the undissociated indicator acid, and f_1 the same for the ions, equation (4) can be written in the following form:

$$\frac{f_0 [HI]}{f_1 [I^-]} = \frac{[aH^+]}{K_I} \quad (5)$$

The color of the indicator is determined by the ratio of the concentrations and not of the activities of $[HI]$ to $[I^-]$:

$$\frac{[HI]}{[I^-]} = \frac{[aH^+]}{K_I} \cdot \frac{f_1}{f_0} \quad (6)$$

In the first chapter, paragraph 2, we saw that the activity coefficient of an ion decreases with increasing ionic strength of a solution, while that of undissociated molecules increases as a rule. The latter effect, however, will be neglected for the present purpose.

Suppose now we have the same indicator in two different solutions having the same hydrogen-ion activity, one having an ionic strength of 0.001, and the other of 0.1. In the latter solution f_1 will be smaller than in the former, and according to equation (6) $[HI] : [I^-]$ will be smaller in the solution with an ionic strength of 0.1 than in the solution with the same hydrogen-ion activity but with an ionic strength of 0.001. In other words, the color of the indicator in both solutions is not the same, but it will have a more acid shade in the liquid with the smaller ionic strength. With an indicator base instead of an indicator acid just the reverse effect would be observed.

In the colorimetric measurement of pH as a rule buffer solutions are used with an ionic strength of 0.05 to 0.1. If the indicator in the solution to be tested has the same color as in some buffer mixture, their pH (or better $p_aH = -\log [aH^+]$)

will be the same, only if both solutions have the same ionic strength. If an indicator acid is used and the solution to be tested has an ionic strength smaller than the buffer mixture, the pH (paH) found by colorimetric measurement is too high, and a correction has to be applied (subtracted) for the difference between the ionic strength of the buffer mixture and the solution to be tested. This correction is called the *salt correction*, and depends first upon the ionic strength of the buffer solution used for comparison. As a rule the ionic strength of the ordinary buffer solutions is of the order of 0.1, and we will relate the *salt corrections* listed below to this ionic strength. However, the salt correction does not depend solely upon the difference in ionic strength between the buffer mixture and the solution tested, but also upon the kind of ions present and the individual behavior of the indicator.¹³ Theoretically, it can be derived that the salt correction will be larger for an indicator, the acid form of which is a monovalent anion and the alkaline form a divalent anion (sulfonphthaleins, phenolphthalein) than for the case in which the acid form is an uncharged molecule and the alkaline form a monovalent anion (nitrophenols). For methylorange and methylred the salt error is negligibly small on account of the hybrid character of the dimethylaminoazobenzene sulfonic acid and dimethylaminoazobenzene carbonic acid. Therefore these indicators have distinct advantages in the colorimetric pH measurement. In the following table the salt corrections for various indicators are reported in solutions of different ionic strength. It is assumed that comparisons are made with buffer solutions with an ionic strength of 0.1.

A positive correction (+) means that the figure has to be added to the experimental value; a negative sign (−) means it has to be subtracted, if comparisons are made with a buffer with an ionic strength of 0.1.

Example.—Colorimetrically, it is found that an acetic acid-sodium acetate buffer with an acetate concentration of 0.005 N

¹³ A review of the complicated relations is given in J. Phys. Chem., **32**, 1820 (1928).

SALT CORRECTION FOR INDICATORS AT VARIOUS IONIC STRENGTHS

(Ionic Strength of Buffer Solution Used for Comparison is 0.1)

Ionic Strength	T. B.*	M. O.	B. P. B.	B. C. G.	M. R.	C. P. R.
0.0025	.	-0 04	+0 15	+0 21	0 00	
0.005	.	-0 04	+0 14	+0 18	0 00	+0.15
0 01	0 00	-0 02	+0 14	+0 16	0 00	+0 13
0.02	0 00	0 00	+0 13	+0 14	0 00	+0.12
0 05	0 00	0 00	+0 10	+0 05	0 00	+0 05
0.1	0 00	0 00	0 00	0.00	0 00	0 00
0 5 (KCl)	0 00	0.00	-0 10	-0 12	0.00	-0 16
0 5 (NaCl)	0 00	0 00	-0 18	-0 16	0 00	-0 19

* T. B. in its acid range (pH 1.3 - 2.8)

Ionic Strength	B. T. B.	P. R.	T. B.	Ppht.	Thpht.
0 0025	+0 14	+0 14			
0 005	+0 12	+0 12	+0 16	+0 18	
0 01	+0 11	+0 11	+0 12	+0 12	+0 11
0 02	+0 07	+0 07	+0 09	+0 10	+0 09
0 05	+0 04	+0 04	+0 05	+0 05	+0 05
0 1	0 00	0 00	0 00	0 00	0 00
0 5 (KCl)	-0 20	-0 20	-0 12	-0.16	-0 19
0 5 (NaCl)	-0.28	-0 29	-0 19	-0 21	

T. B. = Thymolblue

M O. = Methylorange

B P B = Bromphenolblue

B. C. G. = Bromcresolgreen

M R. = Methylred

C. P. R. = Chlorphenolred

B T B = Bromthymolblue

P. R. = Phenolred

Ppht = Phenolphthalein

Thpht. = Thymolphthalein

has a pH of 4.8, using bromcresolgreen as an indicator and an ordinary buffer solution for comparison. Then the corrected pH is $4.8 + 0.18 = 4.98$. To another dilute acetic acid-acetate buffer 0.5 N sodium chloride is added (which decreases its pH). Using the same indicator, a pH of 4.80 is found. Then pH corr. = $4.8 - 0.16 = 4.64$. It should be emphasized that at higher ionic strengths (above 0.1) the type of ions present has relatively much influence upon the correction; and therefore the result of the colorimetric measurement is more or less uncertain.

Finally, a few words may be said of the pK_i values of indi-

cators tabulated on p. 46 and p. 49. It has been indicated there that pK_I is a function of the ionic strength. According to equation (6):

$$\frac{[HI]}{[I^-]} = [aH^+] \frac{f_1}{f_0} \frac{1}{K_I} \quad (\text{monobasic indicator acid}); \quad (6)$$

whereas in the computation of pH from colorimetric measurements we have *assumed* that

$$\frac{[HI]}{[I^-]} = \frac{[aH^+]}{K'_I} \quad (7)$$

However, K'_I in the last equation is not constant, because f_1/f_0 (equation 6) changes with the ionic strength; and it is easily seen that for indicator acids K'_I (equation 7) increases with the electrolyte content of the solution or pK'_I decreases.

(c) *The Protein Effect*.—It was Sørensen who showed that proteins may render the colorimetric determination of pH difficult or impossible. The effect is more or less specific and depends upon the kind of protein present and the indicator used. As a rule the positively charged protein (acid side of the isoelectric point) exerts a larger influence than the negatively charged protein (alkaline side of the isoelectric point). Especially the diazo indicators are affected by the positively charged protein hydrates. On the other hand, in casein and egg albumin solutions of pH around 5.0 (near the isoelectric point), methylred gives reliable results.¹⁴

Quite generally, therefore, in the presence of proteins, it is not safe to rely upon the data obtained by the colorimetric method unless they have been controlled by the potentiometric method (hydrogen electrode).

(d) *Other Factors*.—In colloidal solutions (*cf.* also above under Protein Effect) the indicator equilibrium in the solution may be

¹⁴ Several examples of the deviation shown by indicators of different type in various kinds of protein solutions are given in W. M. Clark, *The Determination of Hydrogen Ions*, Third Edition, pp. 184 and 185; and I. M. Kolthoff, *Indicators*, pp. 180, 181.

changed on account of a specific adsorption of the either acid or alkaline form of the indicator. Under such conditions an entirely wrong value of the pH of the solution is obtained. So for example if neutral red is added to a soap solution with a pH of about 11 (strongly alkaline to phenolphthalein) it assumes a reddish color, owing to an adsorption of the acid form of the indicator by the colloidal fatty acid particles.

Even in the presence of finely divided particles the indicator may assume a color not corresponding to the pH of the solution, on account of a surface reaction. A striking example is an experiment with lanthanum hydroxide: A saturated solution of the latter in water has a pH of about 9.0. If some of the hydroxide is shaken in water and thymolphthalein is added, the suspension assumes a dark blue color, indicating that pH is larger than 10.5. However, what happens is that the indicator, reacting with the hydroxyl ions on the surface of the hydroxide, is transformed into the alkaline form, and remains adsorbed as such (blue form) on the surface. If the suspension is allowed to settle, the supernatant liquid will be colorless.

There is also a possibility that the ionization constant of the indicator will be changed at the interface between two substances. This can be shown to be true for the interface water-air by the following experiment: Thymolblue in a solution with a pH of about 2.6 has a yellowish-orange color. On violent shaking with air the mixture turns nicely red and forms a red froth; on standing it assumes its original color. The indicator has a larger ionization constant at the interface air-water than in aqueous solution. By shaking with air the interface increases considerably, and the effect is demonstrated by the color change and the formation of a red foam.

Quite generally in the presence of finely divided substances and in colloidal solutions one has to be careful with the results of the colorimetric method. A verification with the hydrogen electrode is highly desirable. Moreover, it may be recommended to repeat the colorimetric determination with an indicator of different type from the one used before. If, for example, an indi-

cator acid has been used, it is advantageous to repeat the readings with an indicator base.

At the end of this chapter it may finally be emphasized that the data on the indicator constants hold only for water as a medium. If organic solvents, like alcohol, acetone, etc., are added to water, all equilibrium constants change. If the color of an indicator in some solution in an alcohol-water mixture is compared with that of the same indicator in an aqueous buffer solution, the same color does not mean the same pH (*cf.* p. 33.)¹⁵

PROBLEMS ON INDICATORS

1. An indicator has an indicator constant of 5.00 ($= -\log K_I$). What is its color-change interval, if 5 per cent of the acid form can be perceived by the naked eye in the presence of 95 per cent of the alkaline form, and 10 per cent of the latter in the presence of 90 per cent of the acid form?

2. Bromphenolblue (indicator acid) and methylorange (indicator base) both have a transition color in 10^{-4} N hydrochloric acid. In what direction does the color of the indicator change on heating, assuming that the ionization constant of the indicators does not change? Compute how much the ratio of the acid to the basic form of the indicators changes on heating from 25° to 100° ($K_w = 10^{-14}$ at 25° and 10^{-12} at 100°), assuming that the ratio at 25° is 1 : 1?

3. In a mixture of water and alcohol the indicator constant of bromphenolblue is 10 times smaller than in water, that of methylorange 10 times larger. Calculate the sensitivity of both indicators for hydrogen ions, if the acid form of both of them in pure water is just perceptible at $[H^+] = 10^{-4}$.

4. On adding 0.1 c.c. of a 0.1 per cent solution of phenolphthalein to 10 c.c. of a borate buffer mixture, it is found that 50 per cent of the indicator is transformed into the alkaline form. What is the concentration of the alkaline form, if 0.2 and 0.5 c.c. indicator solution, respectively, are added to 10 c.c. of the buffer mixtures?

5. Calculate the ratio of acid to basic form of an indicator acid with an ionization constant of 10^{-6} in buffer mixtures with a pH of 4.0; 4.5, 5.0, 5.3, and 6.0. Between what range in pH would you use the indicator for colorimetric work?

6. The pH of a solution is measured with bromcresolgreen ($pK_I = 4.70$) as an indicator without the use of a buffer solution. It is found that the

¹⁵ Correction for the influence of alcohol, see, e.g., I. M. Kolthoff, *Indicators*, p. 183.

ratio of the yellow to the blue form is 40 : 60. What is the pH of the solution?

7. An indicator base, red in acid, colorless in alkaline medium, with an ionization constant K_b equal to 10^{-9} (not $K_I!$), is used for the colorimetric determination of pH without buffer solutions, at 25° ($K_w = 10^{-14}$). Ten cubic centimeters of the solution to be tested are added to 1 c.c. of 0.01 per cent indicator solution. By comparing with solutions of the indicator in 0.01 N hydrochloric acid it is found that 0.4 c.c. of the 1 c.c. indicator added is transformed into the acid form. What is the pH of the solution?

8. Calculate the change of pH in the neutralization of the following acids (after addition of 0 per cent, 10 per cent, 50 per cent, 90 per cent, 99 per cent, 100 per cent, 101 per cent of the equivalent amount of sodium hydroxide) and assume that the volume does not change during the neutralization: 0.1 N HCl; 0.01 N HCl; 0.1 N acetic acid ($K_a = 1.8 \times 10^{-5}$); 0.1 molar boric acid ($K_a = 10^{-9}$). Combine the results in a graph, plotting the pH figures on the ordinate, and the percentage of acid neutralized on the abscissa. Draw arrows on the graph, indicating the range of distinct color change of methylorange (or bromphenolblue); methylred (or bromcresolgreen), phenolred, and phenolphthalein (or thymolblue). Show which indicators can be used for the detection of the quantitative neutralization of the above acids.

9. Calculate the ratio of the acid to the basic form of the indicator in the colorimetric measurement of the pH of distilled water in equilibrium with the atmosphere. Use methylred and bromcresolgreen as indicators; pK of methylred is 5.00; of bromcresolgreen 4.90. Normal air contains 0.03 vol. per cent CO_2 ; distribution coefficient of CO_2 between water and air is 1, and the first ionization constant of carbon dioxide 3×10^{-7} .

10. Bromthymolblue is added to two phosphate buffer mixtures of the same pH (or paH), one having an ionic strength of 0.01, the other of 0.25. Does the indicator have the same color in both solutions? If not, which of the two will show a more alkaline color? What would be the effect, if an indicator base were used instead of bromthymolblue?

PART II

THE POTENTIOMETRIC MEASUREMENT OF pH . POTENTIOMETRIC TITRATIONS

CHAPTER IV

ELECTRODE POTENTIALS

1. The Potential of a Metal Electrode.—If a metal is placed in a solution of its salt, there will be a difference of electrical potential between metal and solution, which depends upon the concentration (activity) of the metal ions in the solution and the specific nature of the metal. Nernst (1889) assumed that a metal possesses a characteristic solution tension comparable with that of benzoic acid or other substances, but with the difference that the metal sends ions into the solution. If the metal is dipped into pure water, metal ions which have a positive charge will go into the solution, whereas the metal itself, of course, must assume a corresponding negative charge. On account of the relatively strong electric charges of the ions, only a few can be sent into the solution; the negatively charged metal attracts the positively charged metallic ions, and a state of equilibrium is soon reached whereby the metallic ions are kept opposite the negatively charged metal in a so-called *electrical double layer*. In the state of equilibrium the electrostatic force equalizes the solution pressure. If the liquid already contained some of the metallic ions, fewer would escape from the metal, and the charge of the latter would be less negative (or more positive than in the preceding case). The osmotic pressure of the solution has a tendency to force the ions out of the solution. If

this force is smaller than the *electrolytic solution tension* of the metal, the latter will have a negative charge, and the liquid a positive charge. For the case where both tensions equalize each other there will be no potential difference between metal and solution; and finally when the solution tension is smaller than the osmotic effect, the electrode will be positive and the liquid negative. The case is not typical of metals alone, but of all substances which can send ions into the solution. Imagine that we have a rod of iodine in water; then the iodine has a tendency to send iodide ions into the liquid phase. Correspondingly, the iodine will have a positive charge, with regard to the liquid phase.

From the above it is evident that the potential difference between a metal and the surrounding solution (we will call this potential difference the potential of the electrode) will mainly depend upon two factors, which counteract one another: the electrolytic solution pressure P , a constant for each metal, and the ion concentration in the solution. The quantitative relation between these two factors and the potential E of the electrode has been derived by Nernst. Let the electrode be of such size that one gram mole of ions of charge n , carrying nF faradays of electricity (a faraday is the number of coulombs carried by a gram equivalent of an ion) can pass from the electrode to the solution, increasing the partial osmotic pressure by dp . The change in the potential (difference) between the electrode and the solution will be dE . The electrical work expended will then be $nFdE$, and the work taken up by the system will be Vdp . Hence, if the process is reversible:

$$nFdE = Vdp.$$

According to the gas laws:

$$V = \frac{RT}{p},$$

and

$$dE = \frac{RT}{nF} \frac{dp}{p}$$

Integrating this equation gives:

$$E = \frac{RT}{nF} \log_e p + C \quad (1)$$

(\log_e is the natural logarithm to the base e) whereas C is some integration constant.

Equation (1) can be written instead:

$$E = \frac{RT}{nF} \log_e \frac{p}{P}, \quad (2)$$

where P is a measure of the electrolytic solution tension of the metal. In dilute solutions p is proportional to the ion concentration or better to the activity of the ions. Therefore equation (1) can be rewritten in the following form:

$$E = \frac{RT}{nF} \log_e a_{\text{ion}} + C', \quad (3)$$

where a_{ion} denotes the activity of the ion in the solution. In the following we will write the classical expression

$$E = \frac{RT}{nF} \log_e c_{\text{ion}} + C', \quad (4)$$

where c_{ion} is the ion concentration, though it should be emphasized that it is the activity, and not the ion concentration, which is found by potentiometric measurements. By introducing the known values for the various constants, and transposing the natural logarithm into the common logarithm by multiplying by 2.3026, equation (4) can be written in a simpler form:

$$\begin{aligned} R &= 8.315 \text{ international joules or volt-coulombs,} \\ F &= 96,500 \text{ coulombs;} \end{aligned}$$

hence

$$\frac{R}{F} \log_e = \frac{8.315}{96,500} \times 2.3026 \log_{10},$$

or

$$E = 0.0001984 \frac{T}{n} \log_{10} c_{\text{ion}} + C'. \quad (5)$$

At a temperature of 25° C.,

$$T = 298,$$

and

$$E = \frac{0.0591}{n} \log_{10} c_{\text{ion}} + C' \quad (25^\circ) \quad (6)$$

or at other temperatures t° C.:

$$E = \frac{0.0591 + 0.0002(t - 25)}{n} \log_{10} c_{\text{ion}} + C' \quad (7)$$

If the ion concentration or better the ion activity in the solution is equal to 1:

$$E = C'. \quad (8)$$

It is impossible to measure a single potential difference (E) between an electrode and a solution with any degree of accuracy. To overcome this difficulty some other constant electrode is used, and the E.M.F. of the cell built up from these two half-cells is measured. As the potential of the reference electrode is constant, the electromotive force of the element built up from the two half-cells will change exactly according to equation (7).

There is an international agreement to relate all data to the normal hydrogen electrode (*cf.* p. 76) the potential of which can be put *arbitrarily* equal to zero. Its absolute potential is immaterial for our purpose, as the normal hydrogen electrode is only used as a standard reference electrode. The E.M.F. measured against this standard-electrode is usually denoted as E_{H} .

Coming back to equations (7) and (8) we find that in a solution, the ion concentration (ion activity) of which is equal to 1:

$$E_{\text{H}} = C'' = \epsilon_0 \text{ (or } \epsilon_{0\text{H}})$$

ϵ_0 is usually called the *normal potential* of the electrode; it represents the E.M.F. (against the normal hydrogen electrode) of a metal in a solution whose ion activity is equal to 1.

$$E_{\text{H}} = \epsilon_0 + \frac{0.0591}{n} \log_{10} c_{\text{ion}} \quad (25^\circ) \quad (9)$$

(where n is the valence of the metallic ions).

Actual values of ϵ_0 for various metals are more or less uncertain, on account of our limited knowledge of ion activities in solutions, but a few which are of particular importance with regard to the content of this text are given in the following table. Here, the metals are placed in the order of decreasing solution potentials.

NORMAL POTENTIALS OF SOME METALS

Metal	n	ϵ_{0H}	Metal	n	ϵ_{0H}
Zinc	2	-0 76	Antimony.....	3	+0 2
Chromium.....	2	-0 56	Bismuth.....	3	+0 23
Chromium.....	3	-0 51	Arsenic.....	3	+0 3
Iron	2	-0 44	Copper.....	2	+0 345
Cadmium	2	-0 40	Copper.....	1	+0 522
Thallium	1	-0 336	Thallium	3	+0.72
Cobalt	2	-0 255	Mercury (to Hg_2^{++}) ..	2	+0 793
Nickel.....	2	-0 250	Silver	1	+0.808
Tin.....	2	-0 14	Palladium.....	2	+0 82
Lead.....	2	-0 130	Mercury (to Hg^{++})...	2	+0 86
Iron	3	-0 04	Gold.....	3	+1 38
Hydrogen H_2 (gas) .	2	0 00	Gold.....	1	+1.5

2. Oxidation-reduction potentials.—When a metal goes into solution with formation of metallic ions it gives off electrons; on the other hand, in the electro-deposition of a metal the metallic ions combine with electrons:

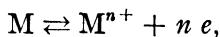

where e represents an electron.

The electron transfer is a process of oxidation-reduction, any substance giving off electrons being oxidized, and a substance taking up electrons being reduced. The electrolytic solution or deposition of a metal therefore is only a special case of oxidation and reduction. In a more general way the process can be expressed by the reaction:



Ox represents the substance in the oxidized form, and is called the

oxidant; Red denotes the substance in the reduced form and is called the *reductant*. An oxidant and a reductant always form a *conjugate* pair, at least if the electron transfer is reversible. If an oxidant exerts its oxidizing power it is transformed into the corresponding reductant and conversely; for example, in the case where a metal M reduces some oxidant like ferric iron, it is transformed into the oxidized form, which are the metal ions. In all oxidation-reduction reactions we are dealing with two conjugate systems of Ox and Red, and electrons furnished by the reductant of one system reacting with the oxidant of the other system.

In the classical definition of oxidation-reduction reactions it was assumed that hydrogen and oxygen are the proto elements for such processes. Addition of hydrogen or withdrawal of oxygen meant reduction, while withdrawal of hydrogen or addition of oxygen was specific for oxidation. Though it is possible, as a rule, to reduce all oxidation-reduction reactions to the classical scheme, there is still no urgent reason to believe that hydrogen and oxygen take such a special position amongst all the elements with regard to oxidation and reduction. Considering the reduction of ferric iron to ferrous iron— $\text{Fe}^{+++} \rightleftharpoons \text{Fe}^{++} + e$ —there is a simple transfer of an electron from the ferric to the ferrous state.

At first view there is no objection to using the classical scheme and having the reduction of the ferric iron effected by hydrogen:

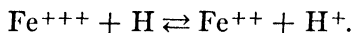

Actually, it is known that strong reducing agents like chromous chromium, or titanous solutions, under certain conditions can reduce hydrogen ions to uncharged hydrogen. However, with decreasing reducing action of the system or increasing oxidizing power the reaction between the reduced form and hydrogen ions,

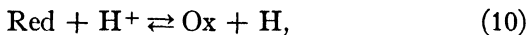

takes place to such a small extent that the “hydrogen pressure” of the system is extremely low. With strongly oxidizing systems the calculated hydrogen pressure is so low that it no longer has

any actual significance. Theoretically, however, there can be no objection to considering the participation of the hydrogen ion-hydrogen system in oxidation-reduction reactions, since hydrogen ions are present in any aqueous solution. It even has some advantage in the simple derivation of the *oxidation-reduction potential*. If a piece of noble metal like platinum or gold be placed in a solution of an oxidant and its reduced form, there will be assumed a stable potential, which depends upon the characteristics of the system and the ratio of oxidant to reductant in the solution. This potential is called the *oxidation potential* or better the *oxidation-reduction potential* of the system. The potential of a metal-metallic ion solution is a special case of oxidation-reduction potential.

According to equation (9) in paragraph 1 the potential of an electrode of metallic hydrogen (see later, p. 73) against a solution containing hydrogen ions is given by:

$$E_{\text{H}} = \varepsilon_0 + 0.0591 \log_{10} \frac{[\text{H}^+]}{[\text{H}]} \quad (11)$$

where $[\text{H}]$ is the concentration of the atomic hydrogen. Application of the mass action law to equation (10) gives:

$$\frac{[\text{H}^+][\text{Red}]}{[\text{H}][\text{Ox}]} = K$$

$$\frac{[\text{H}^+]}{[\text{H}]} = K \frac{[\text{Ox}]}{[\text{Red}]} \quad (12)$$

Introducing this expression in equation (11) it is found that:

$$E_{\text{H}} - E_{\text{Ox/Red}} = \varepsilon_0 + 0.0591 \log_{10} K \frac{[\text{Ox}]}{[\text{Red}]} = \varepsilon_0' + 0.0591 \log_{10} \frac{[\text{Ox}]}{[\text{Red}]} \quad (13)$$

$E_{\text{Ox/Red}}$ denotes here the oxidation-reduction potential of the system under consideration; it is shown to depend in a very simple way upon the ratio of $[\text{Ox}]$ to $[\text{Red}]$ in the solution. Instead of following the classical views for the derivation of the

oxidation potential, W. M. Clark ¹ prefers to work with what he calls the electron pressure of the system:

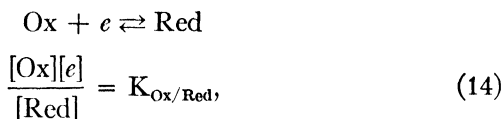

where $[e]$ is a measure of the electron pressure or electron affinity. Though it cannot be denied that this expression is somewhat vague, it offers distinct advantages in the general formulation of oxidation-reduction equilibria.

Considering the equilibrium between a monovalent metal and its ions, we have:

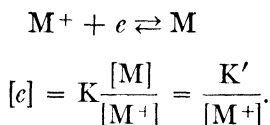

It has been derived (p. 65) that the potential of a metal electrode is given by:

$$-E = \frac{RT}{F} \log_e \frac{P}{[\text{M}^+]}, \quad (2)$$

or

$$-E = \frac{RT}{F} \log_e \frac{P}{K'} [e] = \frac{RT}{F} \log_e K'' [e]$$

$$= 0.0591 \log_{10} K'' [e]. \quad (25^\circ) \quad (15)$$

Equation (15) gives the general relation between the potential of an electrode and the electron activity $[e]$ of the system. It can be applied to all reversible oxidation-reduction systems.

Considering equations (14) and (15), it is found that the oxidation-reduction potential E of the system $\text{Ox} + e \rightleftharpoons \text{Red}$

$$E = 0.0591 \log_{10} \frac{1}{K[e]} = 0.0591 \log_{10} \frac{[\text{Ox}]}{[\text{Red}]K \cdot K_{\text{Ox/Red}}}$$

$$= \epsilon_0 + 0.0591 \log_{10} \frac{[\text{Ox}]}{[\text{Red}]}. \quad (16)$$

¹ W. M. Clark, *The Determination of Hydrogen Ions*, Third Edition, p. 373.

This is the same expression as has been given in equation (13). If more than one electron transfers from one form to the other as in $\text{Sn}^{++++} + 2e \rightleftharpoons \text{Sn}^{++}$,

$$[e] = \sqrt{K_{\text{Sn}^{II}/\text{Sn}^{IV}} \frac{[\text{Sn}^{++}]}{[\text{Sn}^{++++}]}}$$

and

$$E = \epsilon_0 + \frac{0.0591}{2} \log_{10} \frac{[\text{Sn}^{++++}]}{[\text{Sn}^{++}]},$$

or quite generally for the system



$$E = \epsilon_0 + \frac{0.0591}{n} \log_{10} \frac{[\text{Ox}]}{[\text{Red}]} \quad (25^\circ) \quad (17)$$

In various oxidation-reduction systems hydrogen ions take part in the reaction. From the above it will be evident that in such cases the oxidation potential will also depend upon the hydrogen-ion concentration of the solution. If, for example, higher oxides exert their oxidizing action, the reaction may be represented by:

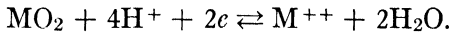

If the reaction is reversible, we find

$$\frac{[\text{MO}_2][\text{H}^+]^4[e]^2}{[\text{M}^{++}]} = K,$$

or, as $[\text{MO}_2]$ is constant on account of the extremely slight solubility of the higher oxides:

$$[e] = \sqrt{K' \frac{[\text{M}^{++}]}{[\text{H}^+]^4}}.$$

Introducing this in equation (15) gives:

$$E_{\text{MO}_2} = \epsilon_0 + \frac{0.0591}{2} \log_{10} \frac{[\text{H}^+]^4}{[\text{M}^{++}]}.$$

In the reduction of most oxidizing anions containing oxygen, hydrogen ions participate in the reaction:

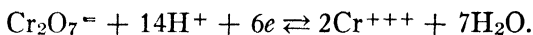
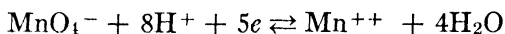

In a similar way it can be derived that

$$E_{\text{MnO}_4^-} = \varepsilon_{0\text{MnO}_4^-} + \frac{0.0591}{5} \log_{10} \frac{[\text{H}^+]^8[\text{MnO}_4^-]}{[\text{Mn}^{++}]}$$

$$E_{\text{Cr}_2\text{O}_7^{=}} = \varepsilon_{0\text{Cr}_2\text{O}_7^{=}} + \frac{0.0591}{6} \log_{10} \frac{[\text{H}^+]^{14}[\text{Cr}_2\text{O}_7^{=}]}{[\text{Cr}^{+++}]^2}.$$

It should be mentioned that these equations do not hold rigorously. The reactions have been written as reversible reactions, which is not quite correct. Intermediate compounds are formed between the oxidized and the reduced form, which are unstable, and their concentration should determine the potential instead of that of the completely reduced form. In a dichromate solution, for example, the trivalent chromium ions have no influence upon the potential. On the other hand, hydrogen ions have an enormous effect upon the oxidation-reduction potential, as indicated by the equations. It is a well-known fact that the oxidizing power of a permanganate solution increases greatly with the acidity. In extremely weak acid medium ($p\text{H}$ about 5-6) it oxidizes iodide to iodine but it does not affect bromide or chloride. At a $p\text{H}$ of about 3 (acetic acid medium) it oxidizes bromide but leaves chloride unattacked. Only at a much higher hydrogen-ion concentration the chloride is oxidized by the permanganate.

Let us consider again the potential of the simple system:
 $\text{Ox} + ne \rightleftharpoons \text{Red}$:

$$E = \varepsilon_0 + \frac{0.0591}{n} \log_{10} \frac{[\text{Ox}]}{[\text{Red}]}, \quad (25^\circ) \quad (17)$$

ε_0 again denotes the *normal potential* of the system expressed against the normal hydrogen electrode as a standard reference

electrode. If $[\text{Ox}] = [\text{Red}]$, $E = \epsilon_0$. However, it should be well understood that concentrations have always been written instead of activities. According to equation (17) the oxidation potential of a certain system depends only upon the ratio of $[\text{Ox}]$ to $[\text{Red}]$, but it is independent of the total concentration of both. In an approximate way this is true; in any exact calculations the change in the activity coefficient of both components should be taken into account. Especially in cases where Ox or Red have a high valence, as in the ferrocyanide-ferricyanide system, the change in the ratio of the activity coefficients on dilution is considerable.

Approximately, however, we are justified in saying that the *intensity* of the oxidizing or reducing action is independent of the ratio of the oxidized to reduced form. On the other hand, the *capacity* to exert an oxidizing or reducing action is determined by the total concentration of both, just as the *buffer capacity* of a buffer solution depends upon the concentration of the acid and its salt.

In the following table (p. 74) normal potentials of various oxidation reduction systems, expressed against the normal hydrogen electrode as a standard, have been collected.

3. Concentration Cells and the Theory of the Hydrogen Electrode. Correction for the Pressure.—Suppose we build up a cell consisting of two hydrogen electrodes, one dipping in a solution of hydrogen-ion activity $[\text{H}^+]_1$, the other in a solution of hydrogen-ion activity $[\text{H}^+]_2$. Neglecting the potential at the boundary phase between the two solutions (*cf.* paragraph 4) we find that the E.M.F. of the above cell is determined by the ratio of the two hydrogen-ion activities; for this reason such a cell is called a *concentration cell*:

$$E_1 = \epsilon_0 + 0.0591 \log_{10} [\text{H}^+]_1$$

$$E_2 = \epsilon_0 + 0.0591 \log_{10} [\text{H}^+]_2$$

$$\text{E.M.F.} = E_1 - E_2 = 0.0591 \log_{10} \frac{[\text{H}^+]_1}{[\text{H}^+]_2} = 0.0591 (\rho\text{H}_2 - \rho\text{H}_1)$$

For each difference of 1 in ρH the E.M.F. of the concentration cell changes 59.1 millivolt at 25°. The E.M.F. of a concen-

NORMAL POTENTIALS OF OXIDIZING-REDUCING SYSTEMS

Reaction Mechanism	ϵ_0
$\text{S} + 2e \rightleftharpoons \text{S}^{2-}$	-0 55
$\text{S} + \text{H}_2\text{O} + 2e \rightleftharpoons \text{HS}^- + \text{OH}^-$	-0 52
$\text{Cu}_2\text{O} + \text{H}_2\text{O} + 2e \rightleftharpoons 2\text{Cu} + 2\text{OH}^-$	-0 35
$\text{V}^{\text{III}} + e \rightleftharpoons \text{V}^{\text{II}}$	-0 2
$\text{CuI} + e \rightleftharpoons \text{Cu} + \text{I}^-$	-0 17
$\text{AgI} + e \rightleftharpoons \text{Ag} + \text{I}^-$	-0 148
$\text{Ti}^{++++} + e \rightleftharpoons \text{Ti}^{+++}$	-0 04
$2\text{HSO}_3^- + 2\text{H}^+ + 2e \rightleftharpoons \text{S}_2\text{O}_4^{2-} + 2\text{H}_2\text{O}$	0 0
$\text{Cu}^{++} + e \rightleftharpoons \text{Cu}^+$	+0 17
$\text{Sn}^{++++} + 2e \rightleftharpoons \text{Sn}^{++}$	+0 2
$2\text{IO}_3^- + 6\text{H}_2\text{O} + 10e \rightleftharpoons \text{I}_2 + 12\text{OH}^-$	+0 21
$\text{VO}^{++} + 2\text{H}^+ + e \rightleftharpoons \text{V}^{+++} + \text{H}_2\text{O}$	+0 4
$\text{O}_2 + 2\text{H}_2\text{O} + 4e \rightleftharpoons 4\text{OH}^-$	+0 41
$\text{Fe}(\text{CN})_6^{3-} + e \rightleftharpoons \text{Fe}(\text{CN})_6^{4-}$	+0 44
$2\text{ClO}_3^- + 6\text{H}_2\text{O} + 10e \rightleftharpoons \text{Cl}_2 + 12\text{OH}^-$	+0 48
$2\text{BrO}_3^- + 6\text{H}_2\text{O} + 10e \rightleftharpoons \text{Br}_2 + 12\text{OH}^-$	+0 51
$\text{W}(\text{CN})_8^{3-} + e \rightleftharpoons \text{W}(\text{CN})_8^{4-}$	+0 51
$3\text{I}_2 + 2e \rightleftharpoons 2\text{I}_3^-$	+0 54
$\text{MnO}_4^- + 2\text{H}_2\text{O} + 3e \rightleftharpoons \text{MnO}_2 + 4\text{OH}^-$	+0 54
$\text{I}_2 + 2e \rightleftharpoons 2\text{I}^-$	+0 58
$\text{H}_3\text{AsO}_4 + 2\text{H}^+ + 2e \rightleftharpoons \text{HAsO}_2 + 2\text{H}_2\text{O}$	+0 58
$\text{BrO}_3^- + 3\text{H}_2\text{O} + 6e \rightleftharpoons \text{Br}^- + 6\text{OH}^-$	+0 60
$\text{MnO}_4^- + e \rightleftharpoons \text{MnO}_4^{3-}$	+0 61
$\text{ClO}_3^- + 3\text{H}_2\text{O} + 6e \rightleftharpoons \text{Cl}^- + 6\text{OH}^-$	+0 62
$\text{Au}(\text{CNS})_4^- + 2e \rightleftharpoons \text{Au}(\text{CNS})_2^- + 2\text{CNS}$	+0 645
$\text{O}_2 + 2\text{H}^+ + 2e \rightleftharpoons \text{H}_2\text{O}_2$	+0 7
$\text{Fe}^{+++} + e \rightleftharpoons \text{Fe}^{++}$	+0 76
$(\text{CNS})_2 + 2e \rightleftharpoons 2\text{CNS}^-$	+0 77
$\text{Mo}(\text{CN})_6^{3-} + e \rightleftharpoons \text{Mo}(\text{CN})_6^{4-}$	+0 82
$\text{Cu}^{++} + \text{I}^- + e \rightleftharpoons \text{CuI}$	+0 85
$\text{ClO}^- + \text{H}_2\text{O} + 2e \rightleftharpoons \text{Cl}^- + 2\text{OH}^-$	+0 90
$2\text{Hg}^{++} + 2e \rightleftharpoons \text{Hg}_2^{++}$	+0 914
$\text{H}_2\text{O}_2 + 2e \rightleftharpoons 2\text{OH}^-$	+1 0
$\text{Br}_2 + 2e \rightleftharpoons 2\text{Br}^-$	+1 087
$\text{IO}_3^- + 6\text{H}^+ + 6e \rightleftharpoons \text{I}^- + 3\text{H}_2\text{O}$	+1 08
$\text{O}_3 + \text{H}_2\text{O} + 2e \rightleftharpoons \text{O}_2 + 2\text{OH}^-$	+1 1
$2\text{IO}_3^- + 12\text{H}^+ + 10e \rightleftharpoons \text{I}_2 + 6\text{H}_2\text{O}$	+1 19
$\text{VO}^{=} + 6\text{H}^+ + e \rightleftharpoons \text{VO}^{++} + 3\text{H}_2\text{O}$	+1 2
$\text{Au}^{+++} + 2e \rightleftharpoons \text{Au}^+$	+1 2
$\text{Ti}^{++++} + 2e \rightleftharpoons \text{Ti}^{++}$	+1 21
$\text{O}_2 + 4\text{H}^+ + 4e \rightleftharpoons 2\text{H}_2\text{O}$	+1 23
$\text{HCrO}_4^- + 7\text{H}^+ + 3e \rightleftharpoons \text{Cr}^{+++} + 4\text{H}_2\text{O}$	+1 3
$\text{MnO}_2 + 4\text{H}^+ + 2e \rightleftharpoons \text{Mn}^{++} + 2\text{H}_2\text{O}$	+1 35
$\text{Cl}_2 + 2e \rightleftharpoons 2\text{Cl}^-$	+1 40
$\text{PbO}_2 + 4\text{H}^+ + 2e \rightleftharpoons \text{Pb}^{++} + 2\text{H}_2\text{O}$	+1 44
$2\text{BrO}_3^- + 12\text{H}^+ + 10e \rightleftharpoons \text{Br}_2 + 6\text{H}_2\text{O}$	+1 49
$\text{MnO}_4^- + 8\text{H}^+ + 5e \rightleftharpoons \text{Mn}^{++} + 4\text{H}_2\text{O}$	+1 52
$\text{MnO}_4^- + 4\text{H}^+ + 3e \rightleftharpoons \text{MnO}_2 + 2\text{H}_2\text{O}$	+1 59
$\text{Ce}^{++++} + e \rightleftharpoons \text{Ce}^{+++}$	+1.6
$2\text{HOBr} + 2\text{H}^+ + 2e \rightleftharpoons \text{Br}_2 + 2\text{H}_2\text{O}$	+1 61
$2\text{HOCl} + 2\text{H}^+ + 2e \rightleftharpoons \text{Cl}_2 + 2\text{H}_2\text{O}$	+1 64
$\text{Co}^{++++} + e \rightleftharpoons \text{Co}^{+++}$	+1 79
$\text{Pb}^{++++} + 2e \rightleftharpoons \text{Pb}^{++}$	+1 8
$\text{O}_3 + 2\text{H}^+ + 2e \rightleftharpoons \text{O}_2 + \text{H}_2\text{O}$	+1 9
$\text{F}_2 + 2e \rightleftharpoons 2\text{F}^-$	+2 85

tration cell H_2 , 0.01N HCl 0.001 N HCl, H_2 will be the same as that of Ag, 0.01 N $AgNO_3$ 0.001 N $AgNO_3$, Ag. If the metal is divalent, then of course the E.M.F. of the concentration cell is given by:

$$\text{E.M.F.} = \frac{0.0591}{2} \log_{10} \frac{[M_1^{++}]}{[M_2^{++}]}$$

Considering a cell built up from two oxidation-reduction electrodes, containing the same oxidation-reduction system, it is easily seen, from equation (17) in paragraph 2, that the E.M.F. of such a cell is determined by the ratio R_1 of [Ox] to [Red] at one electrode to the ratio R_2 at the other electrode.

$$\begin{aligned} E_1 &= \epsilon_0 + \frac{0.0591}{n} \log_{10} \frac{[Ox]_1}{[Red]_1} \\ E_2 &= \epsilon_0 + \frac{0.0591}{n} \log_{10} \frac{[Ox]_2}{[Red]_2} \\ \hline \text{E.M.F.} &= \frac{0.0591}{n} \log_{10} \frac{[Ox]_1}{[Red]_1} \cdot \frac{[Red]_2}{[Ox]_2}. \end{aligned} \quad (18)$$

Metal electrodes, as we have seen, are a special example of oxidation-reduction electrodes; here, as a rule, the concentration of the reduced form [Red] is constant on account of the insolubility of the metal. If the concentration of the metal were variable, the relations would be expressed by an equation similar to (18). Such is the case with the hydrogen electrode. A noble metal coated with a layer of gold, platinum, iridium, palladium, and treated with hydrogen gas, behaves like an electrode of metallic hydrogen. Here the pressure of the hydrogen (concentration of the reduced form) will of course influence the potential of the electrode. Molecular hydrogen is slightly dissociated into hydrogen atoms:



atomic hydrogen behaves like metallic hydrogen, and we find for the potential of this oxidation-reduction system:

$$E = \epsilon_0 + 0.0591 \log_{10} \frac{[H^+]}{[H]}$$

According to equation (19):

$$[\text{H}] = \sqrt{K[\text{H}_2]} = \sqrt{K'p_{\text{H}_2}}$$

where p_{H_2} denotes the pressure of the hydrogen gas. Therefore:

$$\begin{aligned} E &= \epsilon_0 + 0.0591 \log_{10} \frac{[\text{H}^+]}{\sqrt{K'p_{\text{H}_2}}} \\ &= \epsilon_0' + 0.0591 \log_{10} \frac{[\text{H}^+]}{\sqrt{p_{\text{H}_2}}} \end{aligned} \quad (20)$$

Now consider two hydrogen electrodes each in a solution of the same hydrogen-ion activity but under different pressures of hydrogen. If one is under atmospheric pressure ($p = 760$), and the other under a pressure of p mm. mercury, then the cell built up from the two electrodes has an E.M.F.:

$$\begin{aligned} E &= \epsilon_0' + 0.0591 \log_{10} \frac{[\text{H}^+]}{\sqrt{p_{\text{H}_2}}} - \epsilon_0' - 0.0591 \log_{10} \frac{[\text{H}^+]}{\sqrt{760}} \\ &= \frac{0.0591}{2} \log_{10} \frac{760}{p_{\text{H}_2}} \end{aligned} \quad (21)$$

It has been said before that, by international convention, all electrode potentials are referred to the normal hydrogen electrode as a standard (conventionally the zero potential). As Clark (*loc. cit.*, p. 257) expresses it: "The potential at a hydrogen electrode under one atmosphere pressure of hydrogen in a solution of unit hydrogen activity shall be considered to be zero at all temperatures." *This is a definition of the normal hydrogen electrode.*

In most practical work the pressure of the hydrogen will not be exactly equal to 760 m.m. mercury. If the barometric pressure is B , and the vapor tension of the water at the working temperature p_w , the hydrogen pressure is $B - p_w$. The value of E.M.F. measured has to be corrected in order to relate it to one

atmosphere pressure of hydrogen. This correction expressed in volts is easily computed from equation (21).

$$\text{Correction} = \frac{0.0591}{2} \log_{10} \frac{760}{B - p_w}. \quad (25^\circ) \quad (22)$$

In the following table some data are given for the corrections at

CORRECTION IN MILLIVOLTS FOR BAROMETRIC PRESSURE B (IN MILLIMETERS OF MERCURY) AND WATER VAPOR TENSION AT VARIOUS TEMPERATURES

Temp.	B	Water Vapor Tension	Correction in Millivolts
18°	{ 780	15 5	-0 07
	{ 760	15 5	+0 26
	{ 740	15 5	+0 60
25°	{ 780	23 8	+0 06
	{ 760	23 8	+0 41
	{ 740	23.8	+0 76
30°	{ 780	31 8	+0 20
	{ 760	31.8	+0 56
	{ 740	31 8	+0 96
35°	{ 780	42 2	+0 39
	{ 760	42 2	+0 76
	{ 740	42.2	+1 13
40°	{ 780	55 4	+0 64
	{ 760	55 4	+1 02
	{ 740	55 4	+1 41
50°	{ 780	92 5	+1 39
	{ 760	92 5	+1 81
	{ 740	92 5	+2 23
60°	{ 780	149 4	+2 68
	{ 760	149 4	+3.14
	{ 740	149 4	+3.62
70°	{ 780	233 7	+4 88
	{ 760	233 7	+5 43
	{ 740	233 7	+6 00

various temperatures and barometric pressures. If the solution contains some inert gas like carbon dioxide under a pressure p_{gas} , then the correction is

$$\frac{0.0591}{2} \log_{10} \frac{760}{B - p_w - p_{\text{gas}}}$$

As a rule the hydrogen electrode is always negative with regard to the reference electrode. With decreasing hydrogen pressure the potential of the hydrogen electrode will become less negative (at reduced pressure less hydrogen ions are sent into the solution). Therefore, if the hydrogen electrode is the negative pole of the cell and the pressure is smaller than 760 mm. the correction has to be added to the figure measured, in order to relate it to the normal pressure.

Example.—The potential of the hydrogen electrode as measured against some calomel electrode at 25° and a barometric pressure of 740 mm. is -0.5434 volt. Then the corrected value is -0.5442 volt.

4. Liquid-junction Potential.—So far, we have assumed that the E.M.F. of a cell built up from two half-cells is only determined by the difference in potential at both electrodes. This is true only in the approximate way, as a potential difference develops at the junction whenever two solutions of different composition are brought together. The principal cause of the potential difference was attributed by Nernst to unequal rates of diffusion of ions across the junction. The velocity with which ions move under a potential gradient of one volt per centimeter is expressed by the so-called ion mobility. Hydrogen and hydroxyl ions distinguish themselves by a very high mobility as compared with other ions. (See table, p. 135.) Suppose now we have a solution of hydrochloric acid of concentration c_1 and bring this in contact with a similar solution of concentration c_2 , c_1 being larger than c_2 . Then on account of the high mobility of the hydrogen ions the latter have the tendency to diffuse from c_1 to c_2 . On account of the relatively high charge of the ions, the hydrogen ions cannot migrate alone, but they drag the

less mobile chloride ions behind them; and an electrical double layer of hydrogen and chloride ions will migrate. The positive hydrogen ions are in front, and the result will be that the more dilute solution of hydrochloric acid will acquire a positive charge with regard to the more concentrated solution. The potential difference developed is called the *liquid-junction* or *diffusion potential*. As long as we do not work in strongly acid or alkaline solutions (pH between about 3 and 11) the liquid-junction potential as a rule will be extremely small, if partially eliminated by the saturated salt bridge. (See below.) In more extreme cases this device does not eliminate the liquid-junction potential sufficiently, and it has to be determined independently or it can be calculated from the composition of the solution by a complicated equation.² The liquid-junction potential always causes some uncertainty in the results of potentiometric measurements, and for this reason there is no sense in reporting results of E.M.F. measurements with liquid junctions with an accuracy greater than 0.1 millivolt; even this figure is more or less uncertain. Various devices have been proposed to eliminate the liquid-junction potential. As a rule, a saturated solution of potassium chloride is used as a salt bridge, to make electrolytic contact between the liquids in both half-cells. The potassium and chloride ions move approximately with the same velocity. If such a salt is present in very high concentration at a liquid interface, its ions will dominate the conducting of the current. As they migrate with the same velocity, they will tend to eliminate the liquid-junction potential. However, it should be remembered that the liquid junction is not completely removed by the saturated salt bridge, and in measurements of high precision other steps should be taken to account for the liquid-junction potential.

5. The Use of Reference Electrodes (Standard Half-cells).—

In the discussion of concentration cells it has been mentioned (paragraph 3, p. 73) that the E.M.F. of a cell: hydrogen elec-

² For details about the liquid-junction potential compare the corresponding chapter in W. M. Clark, p. 264.

trode/solution to be tested/N hydrogen electrode, is given by the equation:

$$E = 0.0591 \log_{10} \frac{1}{[H^+]}$$

where $[H^+]$ is the activity of the hydrogen ions in the solution to be tested. Therefore

$$pH = \frac{E}{0.0591}. \quad (25^\circ)$$

However, it is impracticable to use the normal hydrogen electrode as a working electrode. Its acidity is so high that the liquid-junction potential at the boundary between the strongly acid solution and the liquid with a larger pH is certainly not

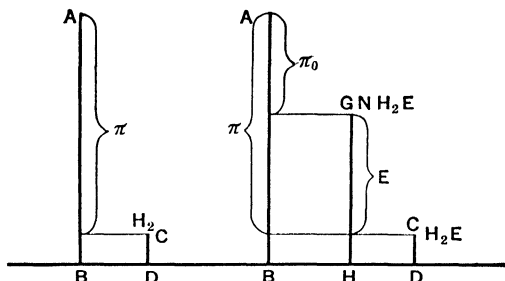

FIG. 4.

eliminated by the saturated salt bridge. Therefore the normal hydrogen electrode is not used as a working reference electrode, but some other *standard half-cell* is used instead. As a rule some kind of calomel electrode (discussion, see p. 93) is taken as a reference electrode.

Suppose that in Fig. 4, AB represents the potential of the calomel electrode, and CD that of the hydrogen electrode. The E.M.F. π measured then is equal to $AB - CD$. What we want to know is the potential difference E between the normal hydrogen electrode (potential GH) and the hydrogen electrode in the unknown (GH - CD). If now the E.M.F. of the cell calomel

electrode – normal hydrogen electrode (AB–GH) is equal to π_0 , it is easily seen from Fig. 4 that $E = \pi - \pi_0$, and

$$pH = \frac{\pi - \pi_0}{0.0591}. \quad (25^\circ) \quad (23)$$

The value of π_0 has been determined for various standard half-cells at different temperatures. The influence of the latter, of course, is not only determined by the temperature coefficient of the standard half-cell but also by that of the normal hydrogen electrode. The data are given on p. 97.

CHAPTER V

THE TECHNIQUE OF POTENTIOMETRIC MEASUREMENTS

1. Principle of the Compensation Method for the Determination of the Electromotive Force of a Cell.—As there are no reliable or simple means for measuring the potential of a single electrode, the latter is always measured against some other standard electrode (standard half-cell). By connecting the two electrodes, a cell or an element is built up, the E.M.F. of which can be measured. If the terminals of the cells were connected with a sensitive voltmeter, no exact results could be expected, as the cell would send a current through the system. This current would cause chemical reactions to occur at both electrodes, and on account of this polarization the E.M.F. of the cell would change during the measurement. Therefore, the procedure usually employed is the Poggendorf-Du Bois-Reymond method, by which the E.M.F. to be measured is balanced by an opposed but known electromotive force. When the unknown is balanced, no current can flow through the cell, which can be indicated by a "null-point" instrument like a galvanometer.

The principle may be illustrated by an arrangement shown in Fig. 5. S is a battery having an E.M.F. greater than that of the unknown cell X, the E.M.F. of which is to be determined. AB is a slide wire of strictly uniform cross section throughout its length, connected to the terminals of the battery by thick copper wires SA and SB of negligible resistance. Hence there is a uniform fall of potential from A to B. The contact C, which slides along the wire AB, is so connected to the unknown element X, that the positive pole of the battery corresponds to the positive

2. General Equipment for Potentiometric Measurements.

Storage Batteries.—The storage battery or accumulator is a convenient and reliable source of current for the potentiometer. When it has been discharged to an E.M.F. below 1.9 volts it must be recharged. It should be remembered that a freshly charged accumulator changes its E.M.F. a little during the first minutes of its discharge. Therefore it is recommended that the accumulator be allowed to discharge for a period of about 10 minutes through a resistance of 1000–5000 ohms before it is used with the potentiometer system. As the battery furnishes some current during the measurements, it is advisable to determine $E_{\text{Batt.}}$ at the beginning and the end of a set of readings. The E.M.F. should not have changed more than 0.1 millivolt. The same holds if dry cells are used instead of an accumulator.

Standard Cells.—

For the calculation of π (equation (1), paragraph 1) it is necessary to know $E_{\text{Batt.}}$. This is determined by switching X out of the circuit and putting in its place a standard cell of known E.M.F. The Weston cell is usually used as a stand-

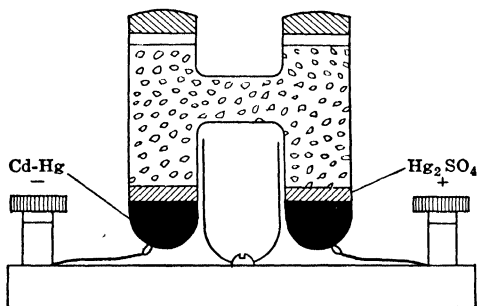

FIG. 6.—Weston standard cell.

ard. The construction of this cell is illustrated in Fig. 6. The “normal” Weston cell contains an excess of cadmium sulfate crystals so that it is saturated at all temperatures at which the cell is used. In the “unsaturated” cell which is often used, the concentration of cadmium sulfate in solution is that of a saturated solution at 4° C. The positive pole of the cell is of pure mercury (purified by nitric acid and redistilled in a vacuum), and is covered with a layer of a paste of mercurous sulfate intimately mixed with mercury. This mixture can be prepared in an electrolytic way. The negative pole is composed of an amalgam

containing 12.5 per cent of cadmium by weight. The amalgam is formed by heating pure mercury over a steam bath and stirring in the pure cadmium. It can also be prepared electrolytically.¹

The temperature coefficient of the "saturated" Weston cell is extremely small.

$$\text{The E.M.F.} = 1.01830 + 0.00004 (20 - t^\circ)$$

between 15° and 25° C.

Null-point Instruments.—As a rule a galvanometer is used as a null-point instrument; it is a current-indicating instrument which usually consists of a coil of wire in the magnetic field of a strong permanent magnet. This coil is introduced into the circuit in which the presence or absence of current is to be detected. A current flowing through the turns of the suspended coil produces a magnetic field which by its interaction with the field of the permanent magnet tends to turn the coil so that it will embrace the maximum number of lines of force. Depending upon the kind of work, galvanometers of various resistances are used. The sensitivity is usually expressed in terms of the resistance through which a unit voltage will cause a given deflection. This is a megohm sensitivity and is defined as the number of megohms (million ohms) of resistance which must be placed in the galvanometer circuit in order that from an impressed E.M.F. of one volt there shall result a deflection of one millimeter. For most potentiometric titrations carried out according to the classical method the small portable galvanometer as furnished by the Leeds and Northrup Co. will serve the purpose (Fig. 7). Its sensitivity is of the order of 1 megohm. For more accurate work the author has used the so-called "portable lamp and scale" galvanometer of Leeds and Northrup (Fig. 8), which is about 20 to 50 times more sensitive than the type in Fig. 7, and is highly recommended for accurate measurements of the ordinary type of cells. Other galvanometers which serve

¹ Cf. Ostwald-Luther, *Physiko-chemische Messungen*, Fifth Edition, 1930; and W. M. Clark, *The Determination of Hydrogen Ions*, Third Edition, p. 342.

various purposes are described in the Leeds and Northrup Co. catalogs.

The capillary electrometer,² which is a volt-indicating instrument, is not as easy to manipulate as the galvanometers and at present it is relatively seldom used for the kind of work under discussion.

If the resistance of the cell to be measured is extremely high (as is the case with the glass electrode, see p. 112) the ordinary type of galvanometer is not sensitive enough to serve

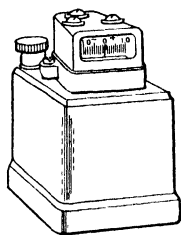

FIG. 7.

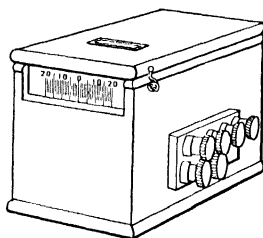

FIG. 8.

as a null-point instrument. Instead resort must be made to the *binant* or *quadrant* electrometer. Compton, Dolezalek, and Lindemann electrometers have been used by various workers, but according to Britton³ the Lindemann⁴ type is the more convenient and easy to manipulate. "This electrometer as supplied by the Cambridge Instrument Co., has a stable zero and does not require levelling. It consists of a needle supported centrally at the midpoint of a quartz fibre, so that it can rotate between four cross-connected plates. The quartz fibre is fixed at both ends under tension so that the centre of rotation of the needle is fixed and the movement of the needle is controlled by the torsion of the fibre; the rotation can therefore be determined by observing the movement of one end of the needle through a microscope. A total magnification of 250 diameters

² Cf. Kolthoff and Furman, *Potentiometric Titrations*, Second Edition, 1930.

³ H. T. S. Britton, *Hydrogen Ions*, p. 98, New York, 1929.

⁴ Lindemann, *Phil. Mag.*, **67**, 578 (1924).

obtained by using a microscope with 100 m.m. tube length, 16 m.m. objective and 10 mm. eye piece enables deflections corresponding to less than one millivolt to be observed. An objective of smaller focus than 16 mm. should not be used as the needle could not then be sharply focussed." In Fig. 9 the potentiometric system using a quadrant electrometer as the null-point indicator is given ⁵ (taken from Britton, p. 98).

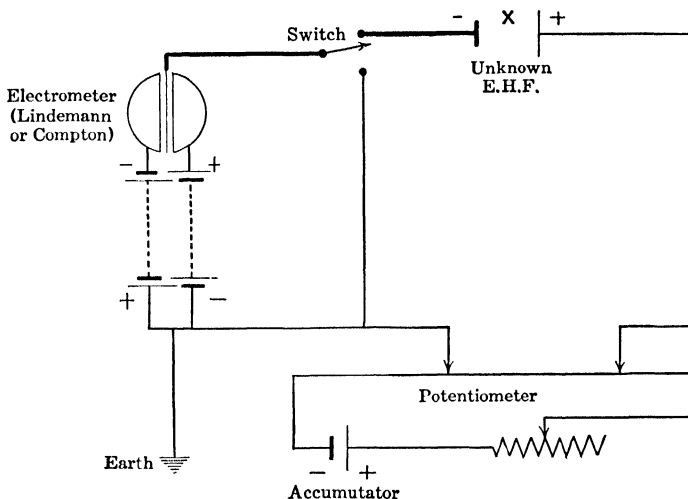

FIG. 9.—Simple circuit for the measurement of the E.M.F. of glass cell.

(Taken from H. T. S. Britton, page 98).

3. The Potentiometer System.—In the discussion of the principle of the potentiometric method (paragraph 1, p. 83), AB represents a slide wire as used in conductivity work. It renders good service in potentiometric titration work, and it is highly recommended to beginners in order to get better acquainted with the principles of the method. By placing a variable resistance (rheostat) between one of the ends of the bridge and the battery and switching in the standard cell, it is easy to adjust $E_{\text{Batt.}}$ at 2 volts.

⁵ For details *cf.* also Kerridge, *J. Sci. Instr.*, **3**, 404 (1926).

Then according to equation (1), paragraph 1, we have:

$$\pi = \frac{CB}{1000} \cdot E_{\text{Batt.}} = \frac{CB}{1000} 2 \text{ volts,}$$

where CB is the length read on the slide wire. Instead of using the stretched wire it is more convenient to have it wound on a drum of hard rubber or other insulating material. These wound slide wires are marketed in various forms.

At present the so-called *potentiometers* are mainly used in potentiometric work. From the didactic point of view they have

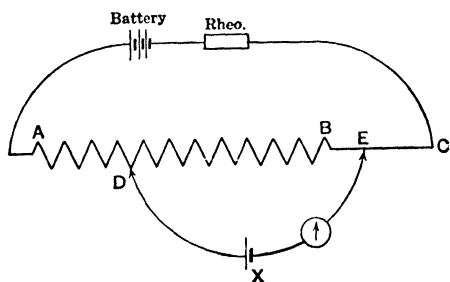

FIG. 10.—Principle of the potentiometer.

the disadvantage of indicating E.M.F. values without forcing the student to understand the principle. On the other hand, the convenience of these instruments is so great that they are generally applied. The so-called “student’s potentiometer,” as supplied by the Leeds and Northrup Co., is of sufficient accuracy for most work. There are more accurate instruments, but on account of the uncertainty caused by the liquid-junction potential, readings more accurate than 0.1 of a millivolt have no actual significance. The principle of the potentiometer is illustrated in Fig. 10.

AB is a set of 22 coils each of 100 ohms resistance, in series with which is an extended slide wire BC of 100 ohms resistance. One contact point D is so arranged that it can make contact between any two of the 100 ohm coils, and a second point E can be brought into contact with any point on the wire. The scale of the extended wire is divided into 1000 equal parts. The terminals of the total resistance of 2300 ohms are brought out to a pair of binding posts. A second pair of binding posts leads to the sliding contact. If by changing D and E the E.M.F. of

X (π) is exactly balanced, we have:

$$\pi = \frac{DE}{AC} E_{\text{Batt.}}$$

DE represents the resistance of DE, and AC that of AC. In our case AC is equal to 2300 ohms; DE is read directly on the instrument. If the E.M.F. of the battery is so regulated by some kind of a resistance that it is equal to 2.3000 volts, we have:

$$\pi = \frac{DE}{AC} E_{\text{Batt.}} = \frac{DE}{2300} \cdot 2.3 = \text{DE millivolts.}$$

Under these conditions therefore the potentiometer indicates directly the E.M.F. of the unknown after the system has been balanced. In order to regulate $E_{\text{Batt.}}$ exactly to 2.3000 volts the normal element is switched in by means of a double throw switch instead of the cell X. At 20° the E.M.F. of the saturated normal cell is 1.0183 volt. The potentiometer switches are set to correspond to the voltage of the standard cell ($DE = 1018.3$), and the regulating resistance Rheo is adjusted until the galvanometer indicates that the circuit is currentless. Then:

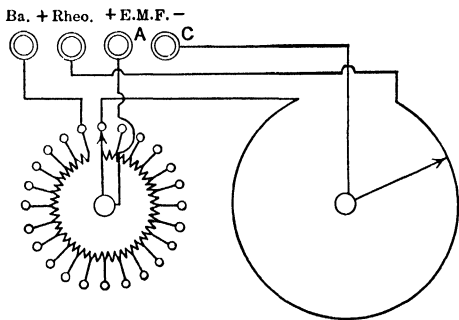

FIG. 11.—Leeds and Northrup student's potentiometer.

$$1.0183 = \frac{1018.3}{2300} E_{\text{Batt.}}$$

$$E_{\text{Batt.}} = 2.3000 \text{ volts.}$$

A sketch of the student's potentiometer is given in Fig. 11. The variable resistance Rheo is the resistance box. Instead of it

two rough rheostats may be used, one having a resistance of 1000–2000 ohms, the other of 10 to 20 ohms. (Fig. 12.)

To make a reading, set the potentiometer switches to correspond to the voltage of the standard cell, and adjust first the

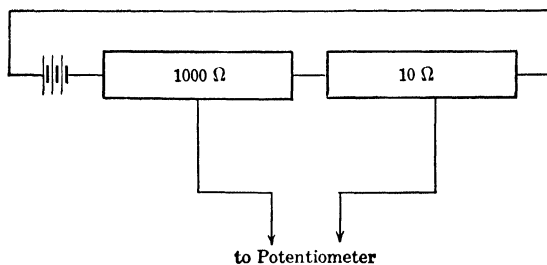

FIG. 12.

rheostat of high resistance roughly and make the finer adjustment with the rheostat of small resistance. When the system is balanced, the E.M.F. between A and C (Fig. 11) is 2.3000 volts. To make a reading of the unknown proceed as follows: Reverse the double throw switch so that the E.M.F. to be measured is

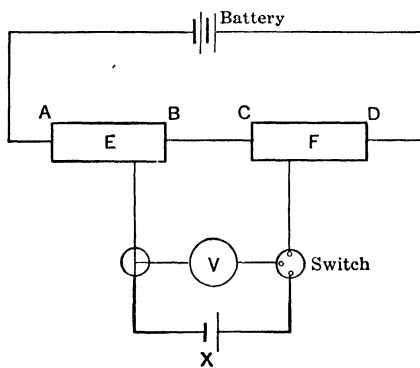

FIG. 13.

brought into the circuit. Now manipulate the two dials of the potentiometer until no current flows through the galvanometer. The unknown E.M.F. (π) is then read off directly. In accurate work it is advisable to adjust $E_{\text{Batt.}}$ after each reading. As a battery two dry cells or two accumulators can be used.

In work where the highest accuracy is not required, as in potentiometric titrations, the E.M.F. of the unknown can be read directly on a millivolt meter by using the following device (Fig. 13): AB is an ordinary rough rheostat of about 1000–2000

ohms; CD is a similar one of about 10–20 ohms. Adjustment is made by changing E and F until no current flows through the galvanometer. Then X is switched out, and by means of a double throw switch the millivolt meter V is switched in. The E.M.F. of X is then read directly on V without using a standard cell at all.

Various other slight modifications of the potentiometer system have been proposed, without introducing, however, distinct advantages over the methods discussed above.

4. The Thermionic Valve Method.—It has been mentioned in the first paragraph of this chapter that in making E.M.F. measurements of a cell every precaution must be taken not to draw any more current from the experimental cell than is absolutely unavoidable, on account of polarization phenomena. In observing the deflection of the galvanometer it therefore is essential just to tap the key for the shortest period in which the observation can be made. By means of the thermionic valve it is possible to make observations without extracting from the cell any appreciable amount of current, though the latter is left continuously in the circuit; therefore, the thermionic valve is of advantage in continuous-reading potentiometric devices, especially in potentiometric titrations. Moreover, it has another distinct advantage in cases where the resistance of a cell is so large that galvanometers of the ordinary type are not sensitive enough. (*Cf.* p. 86.) Goode⁶ first applied the valve to electrometric titrations with the hydrogen electrode.

A is an electron tube exhausted to a very low gas pressure, and is supplied with an atmosphere of electrons emitted from the hot filament *f*. The metallic sheath *p* is called the plate and is maintained by the battery B₂ at a potential positive to the filament. The electrons will migrate from *f* to *p* and establish a current known as the plate current. Between the filament and the plate is placed a grid *g* through which the electrons must pass in their migration from filament to plate. If the grid is charged positively with regard to the filament it will attract the elec-

⁶ Goode, *J. Am. Chem. Soc.*, **44**, 27 (1922); *J. Opt. Soc. Am.*, **17**, 59 (1928).

trons and increase the strength of the plate current; if the grid be negatively charged it will decrease the plate current. Thus, by charging the grid the plate current is changed.

In his work Goode connected the hydrogen electrode, which was the negative pole of the titration cell, to the grid, and the calomel electrode to the negative filament lead. A shunted galvanometer G , the sensitivity of which can be regulated by the

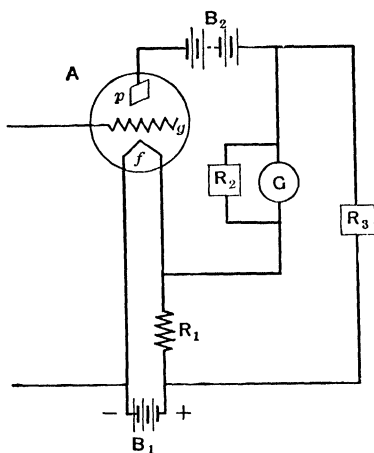

FIG. 14.—Continuous-reading electro-titration apparatus of Goode.

B_1 , 6-volt battery	G , galvanometer
B_2 , 22 5-volt battery.	A , electron tube
R_1 , 0.6 ohm resistance	p , plate.
R_2 , 25 ohm resistance	f , filament
R_3 , balancing resistance (about 1300 ohms).	g , grid

resistance R_2 , detects the plate current. This current with no cell in the grid circuit is opposed by an equal current passing through the galvanometer produced by a potential difference between the two ends of a small resistance placed in the positive filament lead and regulated by a large variable resistance R_1 . Having adjusted the galvanometer circuit so that no current flows through it when there is no applied grid potential, the current registered by the galvanometer when the titration cell is introduced into the grid circuit will be proportional to its E.M.F. The galvanometer therefore may be calibrated in terms of the

applied voltage. An important fact is that steady operation requires a constant filament current.

Various modifications of the Goode arrangement have been proposed; for literature review *cf.* Kolthoff and Furman, *Potentiometric Titrations*, Second Edition (in press); H. T. S. Britton, *Hydrogen Ions*, p. 120; W. M. Clark, *The Determination of Hydrogen Ions*, Third Edition, p. 332.

5. Reference Electrodes.—Calomel electrodes are generally used as reference electrodes. A calomel electrode is one in which mercury and calomel are covered with a potassium chloride solution of definite concentration. A layer of pure mercury is placed on the bottom of the electrode cell and upon this is put a layer of mercury and calomel paste and the potassium chloride solution. The intimate mixture of mercury and calomel can be obtained by rubbing the mercury and calomel together in a mortar so that the mercury is in a very finely divided state, and the mixture has a black or grayish-black appearance. The mixture is washed several times with the potassium chloride solution with which the cell is filled. The intimate mixture of mercury and mercurous chloride can be prepared electrolytically according to Lipscomb and Hulett⁷ or Erving.⁸ The potassium chloride solution, with which the electrode vessel is filled, must be saturated with calomel. This can be done by shaking for some time the chloride solution with calomel or the mercury-calomel paste.

Various forms of calomel electrodes are described in the literature; some are shown in Fig. 15.

Model III is a wide-mouthed bottle, which is well adapted for potentiometric titrations. Through one of the two holes of the stopper passes the siphon which makes electrolytic contact with the solution to be titrated. It is a narrow U-shaped tube filled with a jelly of saturated potassium chloride in agar. This gel is prepared by heating 30 g. potassium chloride, 3 g. of agar and 100 c. c. of water gently, until all has gone into solution and

⁷ G. T. Lipscomb and G. A. Hulett, *J. Am. Chem. Soc.*, **38**, 22 (1916).

⁸ W. W. Erving, *J. Am. Chem. Soc.*, **47**, 301 (1925).

the latter is clear. After all the air bubbles have gone, the siphons can be filled by sucking up the salt-agar solution. On cooling, the solution stiffens to a jelly. The siphons can be kept for a long time if their terminals are placed, when not in use, in a saturated solution of potassium chloride. If the siphons are kept in the air, the jelly dries out, and small air bubbles enter, which cause a high resistance. Such siphons have to be rejected. When the calomel electrode (bottle-type) is not in use, the hole through which the siphon passes is closed by a small rubber

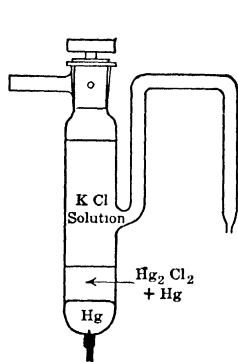

FIG. 15 (I).—Calomel electrode.

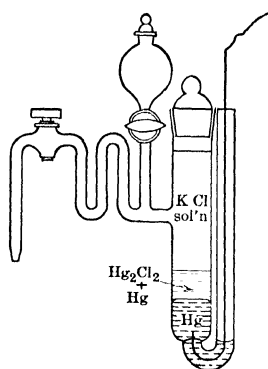

FIG. 15 (II).

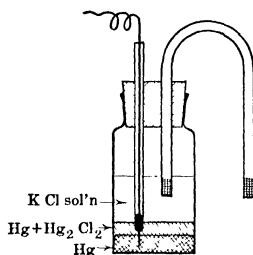

FIG. 15 (III).—Calomel electrode.

stopper in order to prevent evaporation of the solution. Various calomel electrodes are used; they are usually defined by the strength of the potassium chloride solution with which they are filled. When we talk of a 0.1 N calomel electrode we mean that the vessel is filled with 0.1 N potassium chloride. One of the four following calomel electrodes is used: the 0.1 N, the 1 N, the 3.5 N, and the saturated calomel electrode. The potential of these electrodes changes with the temperature; the absolute temperature coefficient (not with respect to the normal hydrogen electrode) is -0.00079 for the 0.1 N; -0.00061 for the 1 N, -0.00046 for the 3.5 N, and -0.00020 for the saturated calomel electrode.

In very accurate work it should be remembered that when a

calomel electrode is brought from a higher to a lower temperature it is very slow in assuming its constant value. Therefore for highly accurate work it is recommended that the calomel electrodes be kept in a thermostat, and not exposed to changes in temperature. This is one of the reasons why the author prefers to use the quinhydrone electrode in accurate work as a standard half-cell. According to the recommendation of Stig Veibel⁹ such an electrode can be easily prepared as follows: Fill a Pyrex tube with a mixture of 0.01 N hydrochloric acid and 0.09 N potassium chloride in water (standard acid mixture) and shake this solution for one minute with 50 to 100 mg. quinhydrone. The tube is closed by a two-hole stopper, one holding the siphon for the salt bridge and the other a glass tube through which the platinum gauze or wire electrode has been sealed. The platinum is ignited to dull redness before being placed in the solution. As the potential of such an electrode is constant for only one or two days it is recommended that the quinhydrone-acid mixture be replaced and the platinum reignited every day.

In measurements of silver, mercury, and halide ion concentrations the saturated salt bridge cannot be used, as chloride would diffuse in the solution to be measured. A special arrangement can be made to prevent this diffusion of the salt into the bulk of the solution. In potentiometric titrations with the silver or mercury electrode, where the liquid-junction potential is more or less immaterial, a salt bridge of potassium nitrate, potassium sulfate, or ammonium nitrate (as a jelly in 3 per cent agar) can be used.

⁹ S. Veibel, *J. Chem. Soc.*, **123**, 2203 (1923).

CHAPTER VI

THE POTENTIOMETRIC MEASUREMENT OF THE HYDROGEN-ION ACTIVITY

1. **The Hydrogen Electrode.**—When a noble metal, coated with an adherent layer of a noble metal to increase its surface, is saturated with hydrogen gas it behaves like an electrode of metallic hydrogen. Various forms of hydrogen electrode vessels have been described in the literature.¹ The form 1 as shown in

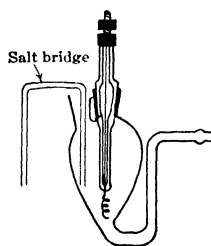

FIG. 16 (I) — Hydrogen electrode in streaming hydrogen.

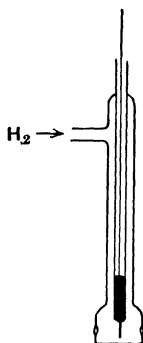

FIG. 16 (II).— Dip electrode according to Hildebrand.

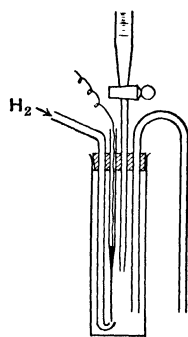

FIG. 16 (III).—H₂ electrode for potentiometric titrations.

Fig. 16 is very well adapted to measurements in streaming hydrogen; as a rule a constant potential is established within two to three minutes. Number 2 in Fig. 16 is a slight modification of the Hildebrand type of electrode and is generally used for potentiometric titrations. The author prefers the type as given

¹ Cf. W. M. Clark, *The Determination of Hydrogen Ions*, 3rd Edition (1928), p. 281.

by Number 3, as the solution can be protected during the titration from oxygen of the air. (See below.)

Depending upon the kind of reference electrode used, the $p\text{H}$ can be calculated by means of one of the following equations:

$\pi_{0.1\text{ N}}$ represents the E.M.F. as measured against the 0.1 N calomel electrode, and corrected for the barometric pressure and water-vapor pressure (reduced to 760 mm. pressure, *cf.* p. 77). $\pi_{1\text{ N}}$ represents the E.M.F. against the normal calomel electrode, etc. $\pi_{\text{Quinh.}}$ is the E.M.F. measured against the quinhydrone electrode in a mixture of 0.01 N hydrochloric acid and 0.09 N potassium chloride (standard acid mixture).

STANDARD EQUATIONS FOR THE CALCULATION OF $p\text{H}$ FROM MEASUREMENTS WITH THE HYDROGEN ELECTRODE

$$0.1\text{ N C.E. } p\text{H} = \frac{\pi_{0.1\text{ N}} - 0.3376 + 0.00006(t - 25)}{0.0591 + 0.0002(t - 25)}$$

$$1\text{ N C.E. } p\text{H} = \frac{\pi_{1\text{ N}} - 0.2847 + 0.00024(t - 25)}{0.0591 + 0.0002(t - 25)}$$

$$3.5\text{ N C.E. } p\text{H} = \frac{\pi_{3.5\text{ N}} - 0.2522 + 0.00039(t - 25)}{0.0591 + 0.0002(t - 25)}$$

$$\text{Sat. C.E. } p\text{H} = \frac{\pi_{\text{sat}} - 0.2458 + 0.00065(t - 25)}{0.0591 + 0.0002(t - 25)}$$

$$\begin{array}{l} \text{Quinh. electrode } p\text{H} = 2.038 + \frac{\pi_{\text{Q H.}} - 0.6990 + 0.00074(t - 25)}{0.0591 + 0.0002(t - 25)} \\ \text{(in 0.01 N HCl +} \\ \text{0.09 N KCl)} \end{array}$$

At present there is some confusion regarding the actual significance of $p\text{H}$. The figures in the above table, which are based upon Sørensen's pioneer work (1909), have been internationally accepted. In the derivation of the standard values (π_0 ; *cf.* p. 79), Sørensen assumed that the hydrogen-ion concentration in 0.1 N hydrochloric acid or in a mixture of 0.01 N hydrochloric acid and 0.09 N potassium chloride can be calculated from conductivity data on the basis of the ionization theory of Arrhenius. In this way he calculates a hydrogen-ion concentration in 0.1 N hydrochloric acid of 0.09165 corresponding to a $p\text{H}$ of 1.038; and in 0.01 N HCl and 0.09 N KCl of 0.009165 or $p\text{H}$ of 2.038. However, we know now that hydrochloric acid in water behaves like a strong electrolyte, and that it is completely ionized in dilute aqueous solution. Therefore in 0.1 N HCl $[\text{H}^+] = 0.1$ and

$pH = 1.000$; in the standard acid mixture (0.01 N HCl + 0.09 N KCl) $[H^+] = 0.01$ and $pH = 2.000$. On the other hand, the activity of the hydrogen ions in 0.1 N hydrochloric acid is much smaller than 0.1; $[aH^+] = 0.0841$; or $paH = 1.075$; and in the standard mixture $paH = 2.075$.

Therefore the Sørensen values have no exact significance, and if we want to know paH of a solution we have to apply the following relation:

$$paH = pH + 0.04(\pm 0.01),$$

where pH is the ordinary Sørensen exponent. This relation is somewhat uncertain, partly on account of the uncertainty in the elimination of the liquid junction potential. An international agreement on this point is highly desirable.²

Deposition of Coat on the Electrode.—One of the essentials of a hydrogen electrode is that it shall have a good coat of “black” on the metal. As a rule, platinum electrodes are used, though other noble metals like iridium, palladium, gold, etc., can be taken. The electrode is well cleaned in a cleaning mixture (10 per cent potassium dichromate in sulfuric acid), and thoroughly washed with water. Then it is electroplated with a cover of the same noble metal, which can be done by electrolyzing in a solution of 1 to 3 per cent chloroplatinic acid, using a platinum foil or a platinum cylinder as an anode, taking care of an adequate distribution of the current. It is the experience of the author that a thin coat of platinum, barely sufficient to obscure the luster of the polished metal beneath, is preferable to a thick coating. With a thin layer of black, equilibrium is attained much more quickly than with a heavy layer of platinum. This is rather important if measurements are to be made in the presence of organic substances, like benzoates, phthalates, etc. An electrode covered with a thick dense layer of platinum black is then very slow in reaching its constant potential. In the measurement of slightly buffered or unbuffered solutions an extremely thin layer of black has to be used, as platinized platinum in a hydrogen atmosphere adsorbs cations from a solution,

² Cf. W. M. Clark, *The Determination of Hydrogen Ions*, p. 461–488; S. P. L. Sørensen and K. Linderström Lang, *Compt. rend. Lab. Carlsberg*, **15**, No. 6 (1924); I. M. Kolthoff, *Rec. Trav. Chim.*, **49**, 401 (1930).

and leaves the latter more acid.³ The electrode is washed thoroughly with water after the deposition and polarized cathodically in about 0.5 N sulfuric acid. Hydrogen is formed at the electrode, and it reduces chlorine, which is adsorbed from the platinizing liquid. After a vigorous evolution of gas for about ten minutes, the current is discontinued, and the electrode is washed repeatedly, first with cold, and later with tepid water. When not in use, the electrode is kept under water. After having been used for some time, it becomes rather sluggish in attaining its constant potential. Then it has to be cleaned and replated.

Hydrogen Generators.—Electrolytic generators of hydrogen have been employed very frequently, and are especially satisfactory when a moderate supply of hydrogen of the highest purity is required at frequent intervals. A convenient supply of pure hydrogen is also on the market as compressed gas in tanks. For controlling the flow of gas from a high-pressure tank there should be coupled to the valve of the tank a delicate needle valve or a diaphragm valve for the reduction of the pressure. Hydrogen generated from pure dilute sulfuric acid and pure zinc (arsenic free) can also be used. In all cases the gas should be purified by washing it through various solutions before it enters the electrode vessel. As a rule, the following arrangement gives very satisfactory results. The gas is passed through a wash bottle with 0.05 N silver nitrate or 0.1 molar mercuric chloride, then through 0.2 N potassium permanganate, through alkaline pyrogallol (1–2 g. pyrogallol in about 35 c.c. 4 N sodium hydroxide), a wash bottle with very dilute sulfuric acid (about 0.1 N acid, to neutralize alkali which might splash over), two wash bottles of water, then in the thermostat through the solution the pH of which has to be determined and finally through the solution in the hydrogen electrode cell used. The oxygen is not quite completely removed by this arrangement, but it gives excellent results in most measurements when the pH is smaller than 11. If strongly alkaline solutions or liquids with an extremely small buffer action have to be measured it is necessary

³ Cf. I. M. Kolthoff and T. Kameda, *J. Am. Chem. Soc.*, **51**, 2888 (1929).

to remove all traces of oxygen. This can be done by leaving out the wash liquid with alkaline pyrogallol (which gives off a trace of carbon monoxide) and passing the gas over platinized asbestos at 500° C. or copper or nickel wire or gauzes at 500°. The gas is then washed through dilute alkali to remove traces of carbon dioxide which might be present in the gas.

Standard Solutions for Checking the Apparatus.—In the routine measurement of hydrogen-ion concentrations it is desirable to check the system frequently. A solution of well-defined pH can be taken, and if the right value is found it is reasonably certain that the whole system is correct. Any of the buffer solutions whose pH has been established by careful measurements described in the literature (*cf.*, e.g., list on p. 37) can be used for this purpose. The author prefers to use the standard acid mixture (0.01 N HCl + 0.09 N KCl), which can easily be prepared, and the pH of which according to Sørensen is 2.038 (or the paH is 2.075). Clark recommends 1/20 molar solution of pure potassium biphthalate, the pH of which at room temperature (more exactly at 20° C.) is 3.974. Finally 1/20 molar solution of pure borax can be easily prepared; at 18° C. its pH is 9.24; at 25° C., 9.19.

Disturbing Factors in the Use of the Hydrogen Electrode.—Oxygen has a tendency to give the electrode a positive charge, and under some conditions even traces may be very harmful. If the hydrogen gas is prepared practically free from oxygen by the procedure described above, the traces of oxygen left do not interfere with the measurement of well-buffered or acid solutions. The platinum black acts as a catalyst for the combination of hydrogen and oxygen. In the measurement of unbuffered or strongly alkaline solutions care should be taken to remove the oxygen as completely as possible. In refined measurements the use of rubber connecting tubes should be avoided, as oxygen from the air may diffuse through rubber.

Various substances may poison the hydrogen electrode; traces of arsenious trioxide, or arsine and hydrogen sulfide are notorious examples. Another kind of poisoning may occur

when proteins are present. Part of it can be adsorbed by the platinum black as a thin film. The electrode will become sluggish, and cleaning and replating are necessary. Organic substances may interfere as they may be hydrogenated at the platinumized electrode. This is especially the case with aromatic compounds; with most alkaloids and dyestuffs, e.g., the author could not get absolutely reliable results. Even in the presence of benzoic acid or benzoates it takes a long time before the electrode attains equilibrium. A very thin coat of black is recommended in these cases. Aliphatic compounds without double or triple bonds do not interfere, as a rule, unless they have a specific oxidizing (per-acids) or reducing action.

Oxidizing substances quite generally are reduced in the hydrogen electrode (ferric iron, dichromate, permanganate, and under certain conditions nitrate ions). Therefore we cannot make good measurements in the presence of these substances. The same holds for salts of metals which stand below or just above hydrogen in the electromotive tension series; salts of copper, silver, bismuth, mercury, etc., are reduced by the hydrogen electrode, and the latter will behave as an electrode of the corresponding metal.

Finally, the electrode cannot be used in the presence of strongly reducing substances, like stannous chloride, chromous chloride or sulfites, as the electrode would indicate the reduction potential of the reducing system present.

From this review we see that the application of the hydrogen electrode is relatively limited, and it is fortunate that for various determinations we have other electrodes available for the potentiometric measurement of pH .

2. The Quinhydrone Electrode.—The quinhydrone electrode introduced for practical work by E. Biilmann and H. Lund⁴ is a very simple and convenient one for the measurement of pH in neutral or acid solutions.

The quinhydrone electrode is an oxidation-reduction elec-

⁴ E. Biilmann, *Ann. chim.*, (9) **15**, 109 (1921); Biilmann and Lund, *Ann. chim.*, **16**, 321 (1921); **19**, 137 (1923).

trode; the electrode reaction taking place can be represented by the equation:

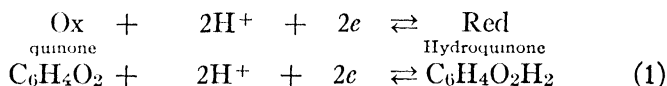

From what has been said in Chapter V, it can be derived that the oxidation-reduction potential of a quinone-hydroquinone system is equal to

$$E = \epsilon_0 + \frac{0.059}{2} \frac{[\text{Quinone}]}{[\text{Hydroquinone}]} + 0.0591 \log [\text{H}^+]. \quad (25^\circ) \quad (2)$$

As quinhydrone is an equimolecular compound of hydroquinone and quinone we have in the solution

$$[\text{Quinone}] = [\text{Hydroquinone}].$$

Therefore in a suspension of quinhydrone we get:

$$E = \epsilon_0 + 0.0591 \log [\text{H}^+] \quad (25^\circ). \quad (3)$$

From this we see that the potential of a quinhydrone-electrode changes exactly in the same way with $p\text{H}$ as the hydrogen electrode does. Therefore the E.M.F. of a cell: hydrogen electrode; —solution $[\text{H}^+]$ | solution $[\text{H}^+]$ | quinhydrone electrode, where both solutions have the same hydrogen-ion concentration, is independent of $p\text{H}$.

According to Büllmann and his collaborators the normal potential ϵ_0 of the quinhydrone electrode (referred to the normal hydrogen electrode) is

$$\epsilon_0 = 0.699 - 0.00074(25^\circ - t^\circ) \quad (\text{between } 0^\circ \text{ and } 38^\circ \text{ C}).$$

Using the quinhydrone electrode against any of the standard half-cells discussed before, the $p\text{H}$ can be calculated by means of one of the following equations:

STANDARD EQUATIONS FOR THE CALCULATION OF pH FROM MEASUREMENTS WITH THE QUINHYDRONE ELECTRODE

$$0.1 \text{ N C.E. } pH = \frac{0.3614 - 0.00068(t - 25) - \pi_{0.1 \text{ N}}}{0.0591 + 0.0002(t - 25)}$$

$$1 \text{ N C.E. } pH = \frac{0.4143 - 0.00050(t - 25) - \pi_{1 \text{ N}}}{0.0591 + 0.0002(t - 25)}$$

$$3.5 \text{ N C.E. } pH = \frac{0.4469 - 0.00035(t - 25) - \pi_{3.5 \text{ N}}}{0.0591 + 0.0002(t - 25)}$$

$$\text{Sat. C.E. } pH = \frac{0.4532 - 0.00009(t - 25) - \pi_{\text{sat}}}{0.0591 + 0.0002(t - 25)}$$

$$\begin{array}{l} \text{Quinhydrone electrode} \\ \text{(in 0.01 N HCl + 0.09 N} \\ \text{KCl)} \end{array} \quad pH = 2.038 + \frac{\pi_{\text{QH}}}{0.0591 + 0.0002(t - 25)}$$

It may be mentioned that the cell hydrogen electrode-saturated calomel electrode has a temperature coefficient larger than any of the other calomel electrodes. The reverse is true for the cell quinhydrone electrode-calomel electrode. If the saturated calomel electrode is used the temperature coefficient is almost negligibly small. As a matter of fact, if the quinhydrone electrode (in the standard acid mixture) is used as a reference electrode in measurements with the quinhydrone electrode there is no temperature modulus at all.

Preparation of Quinhydrone (Biilmann).—Quinhydrone may be suitably prepared as follows: 100 g. ferric ammonium sulfate are dissolved in 300 c.c. water at 65° C., and this solution is poured into a solution of 25 g. hydroquinone in 300 c.c. water. The quinhydrone precipitates in fine needles; after cooling in ice it may be collected by suction. Yield, 15 g. It may be recrystallized from 50 per cent acetic acid in water, whereupon it is washed acid free, but the product prepared according to the method of Biilmann is useful for most purposes without any further purification. It has been our experience, however, that slight traces of acid may be formed at its surface after being kept for some time. These traces of acid are immaterial in the measurement of buffered systems, but if the solution has an

extremely small buffer action large errors may arise. It is recommended in this case to wash the quinhydrone first with water and finally, just before it is used, with the solution to be measured. Or a pure product of quinhydrone which is quite stable can be prepared by mixing solutions of pure hydroquinone and quinhydrone in equimolecular ratio.

Electrodes and Electrode Vessels.—The manipulation of the quinhydrone electrode is extremely simple. As an electrode a bright piece of pure freshly ignited platinum wire, foil or gauze is usually used, but gold electrodes also seem to be suitable. The electrode is ignited in a flame before being placed into the solution. According to J. L. R. Morgan, O. M. Lammert and M. A.

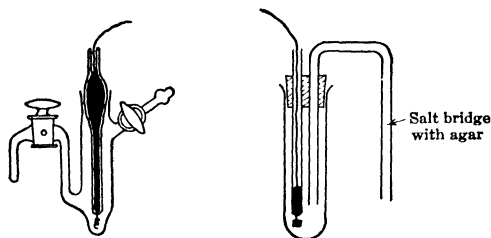

FIG. 17.—Quinhydrone electrode.

Campbell⁵ the greatest source of error in the quinhydrone electrode lies in the sealing of the electrode in the soft glass. Large deviations of the order of 100 millivolts may be found when the glass of the electrode is cracked. For this reason it may be better not to ignite the electrode in a flame, but to clean it in cleaning solution, and wash it later with water. The danger is also avoided when the connection of the electrode to the circuit is made without mercury but by sealing it to a thin platinum wire. The solution is first saturated with quinhydrone, by shaking it for about one minute with 50–100 mg. (for 20 c.c. liquid) of the compound, allowing the excess to settle to the bottom of the vessel. Some suitable forms of electrode vessels are shown in Fig. 17.

⁵Morgan, Lammert and Campbell, *J. Am. Chem. Soc.* **53**, 454 (1931).

In potentiometric titrations some quinhydrone is added to the acid solution; the bright platinum electrode is placed in it; the liquid is stirred and the titration can be started. The quinhydrone electrode may often be applied in cases where the hydrogen electrode does not yield good results, as in the presence of metals which lie below hydrogen in the electromotive series or of many aromatic compounds (alkaloids). In the latter case, however, one should be careful about accepting the results. Both quinone and hydroquinone are substances which react readily with many other compounds. In this way the equilibrium in the electrode may be disturbed. The author, for example, is not convinced that the quinhydrone electrode yields completely reliable results in the presence of substances like aniline, toluidine, phenols, amino acids, etc. A comparison with the hydrogen electrode is desirable if possible.

As the quinhydrone electrode is such a convenient one, it has been used in the last few years for various practical purposes; e.g., for the determination of the acidity of soils, of dairy products, of foodstuffs (like cheese, lemonades, fruit juices, sugar solutions, etc).⁶

Limitations and Sources of Error.—The quinhydrone electrode can only be used up to a certain pH , since hydroquinone is a very weak acid, and in alkaline solution it combines with hydroxyl ions. In general, therefore, good results can be expected only when the pH is smaller than about 8.0, although it is impossible to give an exact upper limit for its usefulness. If measurements are made immediately after the saturation with quinhydrone good results may be obtained up to a pH of 9 in well-buffered solutions. However, in alkaline solutions there is another factor to be considered which is especially essential in potentiometric titrations. In alkaline medium hydroquinone is readily oxidized by oxygen from the air to brown products, some of which have a distinct acid character and may neutralize part of the base.

⁶ For literature references, see W. M. Clark, *The Determination of Hydrogen Ions*, Third Edition, p. 416; Kolthoff and Furman, *Potentiometric Titrations*, Second Edition, 1931.

This oxidation can be avoided by working in an inert atmosphere of nitrogen or hydrogen—this, however, at the cost of the simplicity of the method. In potentiometric titrations, therefore, it is recommended to start always with acid solutions, and to add the base to the stirred liquid. Under such conditions an oxidation of the hydroquinone at the place where the base drops in is avoided.

Another source of error with the quinhydrone electrode is the so-called *salt* error. In the derivation of equations (2) and (3) (p. 102) it has been discussed that since we use quinhydrone, the concentration of quinone is equal to that of hydroquinone in the solution. Actually we should have said that the activity of the two compounds in the solution is the same. This is true as long as we work in pure water as a solvent. Salts, however, change the solubilities of both compounds and, correspondingly, their activities. Therefore the ratio of the two activities in a salt solution may not be the same as in pure water. This change of the activity ratio causes the so-called salt error of the quinhydrone electrode. It has been determined by S. P. L. Sørensen and K. Linderström Lang (1921; 1924) for various concentrations of potassium and sodium chloride and ammonium sulfate. At salt concentrations below 0.5 N the salt error seems to be extremely small. However, it is not certain whether this holds for all salts. The author, in collaboration with W. Bosch, found, for example, that the "salt error" in presence of sodium benzoate is relatively large.

When other oxidation-reduction systems are present which have different oxidation potentials than the solution to be examined they will interfere with exact measurements. So, for example, ferric iron solutions will reduce part of the quinone. Reliable measurements cannot be made in presence of dichromate, permanganate, stannous tin, sulfite, thiosulfate, etc. If the oxidizing or reducing agent acts so slowly that the ratio of hydroquinone to quinone is not appreciably changed within the time of attainment of equilibrium in the system, it does not interfere. Such, for instance, is the case in measurements in the presence of nitric or perchloric acid.

Finally, it may be mentioned that boric acid has the property of forming complexes of relatively strong acidic character with dihydroxybenzenes, like hydroquinone. Therefore, reliable results cannot be expected in presence of boric acid or borates.

3. The Oxygen and Air Electrode.—When oxygen is supplied to an electrode like platinum, it has a tendency to send oxygen ions into the solution just as the hydrogen electrode tends to form hydrogen ions:

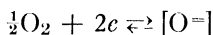

But oxygen ions take up protons in their electron shell, and

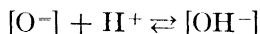

Then,

$$[O^-] = \frac{[OH^-]}{[H^+]}K'$$

and since

$$[OH^-] = \frac{K_w}{[H^+]}$$

we have

$$[O^-] = \frac{K_w K'}{[H^+]^2}$$

The potential of the oxygen electrode is given by:

$$E = \frac{0.0591}{2} \log \frac{P}{[O^-]} \quad (\text{cf. p. 70})$$

$$E = \epsilon_0' + \frac{0.0591}{2} \log \frac{1}{[O^-]} = \epsilon_0' + \frac{0.0591}{2} \log \frac{[H^+]^2}{K_w K'}$$

$$E = \epsilon_0 + 0.0591 \log [H^+].$$

Theoretically, therefore, the oxygen electrode changes its potential with the *pH* of the solution in exactly the same way as the hydrogen electrode. Unfortunately, however, theoretical results are never obtained with such a system on account of the fact that the oxygen electrode is not completely reversible; probably a thin film of the noble metal oxide is formed at the surface. *For this reason, the oxygen electrode never can be a substi-*

tute for the hydrogen electrode in exact work. Still, in certain cases where the hydrogen or quinhydrone electrode fail to give results, it may be of advantage to use the oxygen electrode (ferric iron solutions). It has to be standardized in an empirical way with solutions of known pH .

The oxygen electrode is of more practical significance in potentiometric titrations. As will be discussed in Chapter VII, one of the characteristics of a potentiometric titration is that a large jump in potential occurs at the equivalence point (theoretical end-point). As a rule, readings which are accurate within a few millivolts are satisfactory. Therefore, the oxygen electrode has been repeatedly applied in potentiometric titrations.⁷ The oxygen electrode never reaches a steady potential; the magnitude of the variation is of the order of 5–10 millivolts per hour in acid medium; in alkaline medium it is about six times as great. Instead of supplying the electrode with pure oxygen, air may be used instead. Theoretically one would expect that the air electrode would be 8 millivolts less positive than the oxygen electrode at the same pressure. Actually, the difference is more than ten times greater.

For most practical purposes it is most convenient to work with the air electrode. A bright piece or wire of platinum can serve as electrode. It is of especial advantage in the determination of the acidity of solutions containing strongly oxidizing substances, like permanganate, dichromate, and ferric iron.

Under these conditions the oxygen electrode acts like an ordinary oxidation-reduction electrode.

Higher Oxide Electrodes.—In Chapter V, p. 71, it has been discussed that the potential of a higher oxide electrode is a function of the hydrogen-ion concentration of the solution:

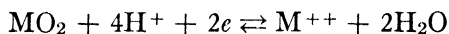

$$E = \epsilon_0 + \frac{0.0591}{2} \log \frac{[H^+]^4}{[M^{++}]}$$

⁷ Cf. Kolthoff and Furman, *Potentiometric Titrations*, Second Edition, 1931.

MO_2 , like MnO_2 or PbO_2 , is slightly soluble. If $[\text{M}^{++}]$ is constant in the solution:

$$E = \varepsilon_0' + 2 \times 0.0591 \log [\text{H}^+].$$

Therefore the potential of the higher oxide electrode changes two times 59.1 millivolts for one unit change in $p\text{H}$. Actually the relations are more complicated, and the higher oxide electrodes cannot be used for exact determinations of $p\text{H}$. In potentiometric titrations, again, they may be useful, especially if strongly oxidizing agents are present. The peroxide (e.g., of lead or manganese) is electrolytically deposited on platinum; the latter then behaves as a peroxide electrode. For analytical work these electrodes are of subordinate significance.

4. Metal-metallic Oxide Electrodes.—In Chapter V (p. 66, equation 9) we have seen that the potential of a metal electrode is given by the equation:

$$E = \varepsilon_0 + \frac{0.0591}{n} \log [\text{M}^{n+}].$$

Suppose now the metal forms a slightly soluble oxide or hydrous oxide, the solubility of which, in the solution to be examined, is negligibly small.



If the solution is saturated to the hydroxide

$$[\text{M}^{++}][\text{OH}^-]^2 = S_{\text{M}(\text{OH})_2}$$

$$[\text{M}^{++}] = \frac{S_{\text{M}(\text{OH})_2}}{[\text{OH}^-]^2} = \frac{S_{\text{M}(\text{OH})_2}}{K_w} [\text{H}^+]^2 = K' [\text{H}^+]^2.$$

Introducing this expression in the above equation we find:

$$\begin{aligned} E &= \varepsilon_0 + \frac{0.0591}{2} \log [\text{M}^{++}] = \varepsilon_0 + \frac{0.0591}{2} \log K' [\text{H}^+]^2 \\ &= \varepsilon_0' + 0.0591 \log [\text{H}^+]. \end{aligned}$$

Therefore the metal-metallic oxide electrode changes its potential with the $p\text{H}$ in exactly the same way as the hydrogen

electrode. The practical application of the metal-metallic oxide electrodes is limited, because the condition has to be fulfilled that the solubility of the hydroxide be negligibly small and that it does not react in any other way with the components of the solution (mercuric oxide forms complexes with various anions; antimony oxide forms complexes with tartrates and other organic hydroxy acids).

The *mercury-mercuric oxide* electrode can be used for the measurement of pH in strongly alkaline solutions ($pH > 9.0$). However, its application is rather limited on account of the fact that it reacts with halides and many other anions with formation of complexes.

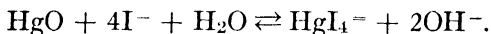

The *silver-silver oxide* electrode can also be used for the measurement of pH in strongly alkaline solutions, but again its application is very limited.

More promising is the *antimony-antimonious oxide* electrode, and much work has been done in the last few years to use this electrode as a substitute for the hydrogen electrode.⁸ The best study of this electrode has been made by E. J. Roberts and F. Fenwick.⁹ They use antimony powder obtained by electrolysis of antimony fluoride and dip a platinum wire into it covered with a thin coat of antimony. Of special significance is the fact that the stable modification of antimonious oxide (cubical form) has to be used. This is obtained by heating precipitated antimony oxide (orthorhombic) in an evacuated Pyrex tube for 24 hours at a temperature of 470° C. If no air is present and the equilibrium is reached from the alkaline side, the antimony-antimonious oxide electrode actually behaves like a hydrogen electrode:

$$E = \epsilon_0 + 0.0591 \log [H^+] \quad (25^\circ),$$

⁸ Review, *cf.* Kolthoff and Furman, *Potentiometric Titrations*, Second Edition, 1931.

⁹ E. J. Roberts and F. Fenwick, *J. Am. Chem. Soc.*, **50**, 2143 (1928).

where ϵ_0 is 0.1445 volt with regard to the normal hydrogen electrode.

However, for practical purposes the method described by Roberts and Fenwick has some disadvantages; the procedure is rather a tedious one and it takes a long time before the electrode has attained its constant potential. Therefore, various authors have tried simpler arrangements. They used an antimony electrode either prepared by electroplating a piece or wire of platinum with antimony, or by using a bright rod of antimony obtained from a melt. In a careful examination with I. Ishimaru, the author was not able to get highly satisfactory results with either of the two electrodes. The potential did not change exactly in a linear way with the pH of the solution. Probably the difficulty is explained by the fact that in none of the cases the form of antimony which is stable at room temperature had been used. This point should be examined further; such a study seems rather promising with regard to the application of the simple antimony electrode as a substitute for the hydrogen electrode.

For potentiometric titrations a satisfactory electrode is obtained if pure antimony (Kahlbaum) is melted in a vacuum, and poured into a cylindrical mold. The melt is cooled very slowly in a vacuum. The rod so obtained is joined to a copper wire, which is connected to the circuit. The rod is placed into the solution and some antimonious-oxide (stable modification) is added to it. The solution is stirred and the titration can be started. If more accurate data of pH are desired, the electrode can be standardized in buffer solutions of known pH . The actual measurements have to be made later under the same conditions, as various factors—absence or presence of air, stirring of the solution or of the electrode—affect the potential more or less.

In the presence of strongly oxidizing substances, like permanganate and dichromate, the trivalent antimony is oxidized to the pentavalent state, and the potential changes very much.

Organic compounds which form complexes with antimonious oxide interfere with measurements with the antimony electrode.

5. The Glass Electrode.—Haber and Klemensiewicz⁹ showed that the potential difference between electrolytes in contact with the two sides of a thin glass wall is determined in part by the hydrogen-ion concentration of the solution. Since then the glass electrode has been subject to many studies, in order to throw more light upon the hydrogen electrode function of this material.¹⁰ The glass electrode behaves as a mixed electrode, not only for hydrogen ions, but also for other ions which may be present in the glass, like sodium, potassium, zinc, etc. If boric acid is present in the glass, the sodium electrode function of the glass enters more in the foreground. Especially in alkaline medium, the mixed electrode function of the glass becomes more pronounced, and no good results can be expected in solutions with a pH larger than about 10.0. With the proper kind of glass¹¹ in acid medium it only changes its potential with the pH of the liquid. According to MacInnes (*loc. cit.*, 1930) the best of the glasses tested has a composition of 72 per cent SiO_2 ; 22 per cent Na_2O ; 6 per cent CaO . The potential at the surface of this glass changes 59.1 millivolt for each unit change in pH up to a pH of 9.5. This

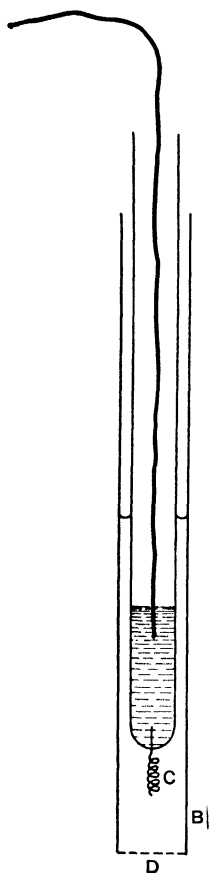

FIG. 18.—Glass electrode of MacInnes.

⁹ Haber and Klemensiewicz, *Z. physik. Chem.*, **67**, 385 (1909).

¹⁰ Cf. W. M. Clark, *The Determination of Hydrogen Ions*, Third Edition, p. 420; H. T. S. Britton, *Hydrogen Ions*, p. 88; Kolthoff and Furman, *Potentiometric Titrations*, Second Edition, p. 1931.

¹¹ See especially the recent studies of D. A. MacInnes and collaborators, *J. Am. Chem. Soc.*, **52**, 29 (1930); *Ind. Eng. Chem., Anal. Ed.*, **1**, 57 (1929); *J. Gen. Physiol.*, **12**, 805 (1929).

limit has no exact significance as it is lowered by the presence of salts in the solution.

MacInnes uses a form of glass electrode, as shown in Fig. 18. A thin glass diaphragm, D, is fused onto the end of an ordinary glass tube B. This tube is then partly filled with an electrolyte (0.1 N hydrochloric acid). Into this electrolyte is placed a silver-silver chloride electrode C.¹² The upper part of the tube is coated inside and outside with a thin layer of paraffin. The thin diaphragm D determines the electrode function of the glass electrode. It is about 0.001 mm. thick and shows colors, owing to interference of light. The diaphragm can be fused on the end of the glass tube in the following way. A bulb is blown on the end of a tube of suitable glass until portions of the film show interfering colors. The end of the supporting tube B is then heated to a low red heat, the correct temperature being found by experience. The heated tube is then placed against the thin bulb. If the conditions are right the film of glass will fuse onto the tube. The potential of the glass electrode can be measured against any standard half-cell. As the resistance of the cell is large, a quadrant electrometer (*cf.* p. 86) has to be used as a null-point instrument.

¹² *Cf.* MacInnes and Beattie, *J. Am. Chem. Soc.*, **42**, 1117 (1920).

CHAPTER VII

POTENTIOMETRIC TITRATIONS

1. The Theory of Potentiometric Titrations. The Equivalence Potential.—It has been stated in the preceding chapters that the potential of a metal electrode is a linear function of the metallic ion exponent in the solution. Therefore the change in potential during a titration is an indication of the change of the metallic ion exponent. At the theoretical end-point of a titration there is an abrupt change of the ion exponent, as a rule, which is indicated by a corresponding jump of the potential of the electrode. Therefore the electrode can be considered more or less as a specific indicator for the corresponding metallic ions in the solution.

Similarly, in an oxidation-reduction reaction the potential of a piece of bright platinum is an indicator for the ratio of the oxidant and the reductant in the solution.

It is of interest to consider what the potential of an electrode will be at the equivalence point, this being the theoretical end-point of the titration.

Neutralization Reactions.—In acid base reactions the pH at the equivalence point is determined by the reaction of the salt formed. If a strong acid be titrated with a strong base, the reaction at the end-point is determined by the ionization product of water. At room temperature (24°) the pH of the electrode will be 7; and

$$E = \varepsilon_0 + 0.0591 \log [H^+] = \varepsilon_0 - 0.0591 \times 7.$$

In the titration of a weak base with a strong acid,

$$pH = 7 - \frac{1}{2}p_b + \frac{1}{2}p_c \quad (\text{equation 24, p. 14})$$

at the equivalence point. If the base is strong and the acid weak,

$$pH = 7 + \frac{1}{2}p_a - \frac{1}{2}p_c \quad (\text{equation 28, p. 14}).$$

The various cases have been discussed in Chapter I, and do not need further consideration here.

Precipitation Reactions.—The ion concentration at the equivalence point is determined by the solubility product S of the slightly soluble substance formed during the titration. If the salt has the composition BA

$$[B^+][A^-] = S$$

then at the equivalence point

$$[B^+] = [A^-] = \sqrt{S}.$$

Simple relations hold for any composition of the precipitate.

$$\begin{aligned} E &= \epsilon_0 + 0.0591 \log [B^+] = \epsilon_0 + 0.0591 \log \sqrt{S} \\ &= \epsilon_0 + \frac{0.0591}{2} \log S \quad (\text{at the equivalence point}) \end{aligned}$$

Oxidation-reduction Reactions.—An oxidant Ox_1 is titrated with a reducing agent Red_2 ; the reaction can be represented by the equation:

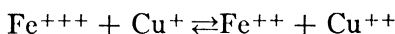
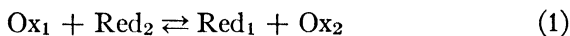

which is governed by the *partial reactions*

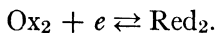
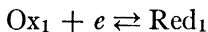

If both systems are present in the solution and the latter is in the state of equilibrium:

$$E = \epsilon_{01} + 0.0591 \log \frac{[Ox_1]}{[Red_1]} = \epsilon_{02} + 0.0591 \log \frac{[Ox_2]}{[Red_2]}, \quad (2)$$

in which ϵ_{01} denotes the normal potential of system one, ϵ_{02} that of system two.

The equilibrium constant of equation (1) is given by:

$$\frac{[\text{Ox}_1]}{[\text{Red}_1]} \frac{[\text{Red}_2]}{[\text{Ox}_2]} = K$$

From (1) and (2) it is seen that

$$\log \frac{[\text{Ox}_1]}{[\text{Red}_1]} \frac{[\text{Red}_2]}{[\text{Ox}_2]} = \log K = \frac{\epsilon_{02} - \epsilon_{01}}{0.0591}. \quad (3)$$

Hence, there is a simple relation between the normal potential of the two systems and their equilibrium constant. At the equivalence point the amount of R_2 added is equivalent to the original amount of Ox_1 , and from equation (1) it is easily seen that the concentration of Ox_1 left in the solution is equal to that of Red_2 , which has not entered into the reaction. Similarly the concentration of the reaction products Red_1 and Ox_2 at the equivalence point are identical; therefore

$$\begin{aligned} [\text{Ox}_1] &= [\text{Red}_2] \\ [\text{Red}_1] &= [\text{Ox}_2]. \end{aligned}$$

From this relation and equation (3) it can be derived that at the equivalence point

$$\frac{[\text{Ox}_1]}{[\text{Red}_1]} = \frac{[\text{Red}_2]}{[\text{Ox}_2]} = \sqrt{K}. \quad (4)$$

According to equation (2):

$$E = \epsilon_{01} + 0.0591 \log \frac{[\text{Ox}_1]}{[\text{Red}_1]}$$

$$E = \epsilon_{02} - 0.0591 \log \frac{[\text{Red}_2]}{[\text{Ox}_2]}$$

$$2E = \epsilon_{01} + \epsilon_{02} + 0.0591 \log \frac{[\text{Ox}_1]}{[\text{Red}_1]} \frac{[\text{Red}_2]}{[\text{Ox}_2]} = \epsilon_{01} + \epsilon_{02}$$

(at equivalence point)

or

$$E_{\text{E.P.}} = \frac{\epsilon_{01} + \epsilon_{02}}{2}.$$

In more complicated cases, where more than one electron enters into reaction, the quantitative relations at the equivalence point can be found in a similar way.

2. Titration Curves. Neutralization Reactions.—The change of the pH of the solution and the variation in the potential of the electrode during the titration can be represented by the same graph, if one unit in pH on the axis corresponds to a change of 59.1 millivolts (at 25°). The curve obtained in plotting the change in potential (or pH) against c.c. reagent added is called the *titration curve*.

From what has been discussed in Chapter I and in this chapter it is a simple matter to construct the titration curve for various cases. For the sake of simplicity, we will assume that the volume does not change during the titration. Under these conditions the pH and the potential have been calculated in the titration of 0.01 N hydrochloric acid with a strong base. The first column in the following table gives the equivalent amount of base expressed in percentages added; the second column, the

TITRATION OF 0.01 N HCl WITH SODIUM HYDROXIDE. $K_w = 10^{-14}$

Per cent Neutralized	$[H^+]$	pH	E_{H_2}	$\frac{\Delta E}{\Delta c}$
0	10^{-2}	2	$\epsilon_0 - 2 \times 0.059$	
90	10^{-3}	3	$\epsilon_0 - 3 \times 0.059$	6.5
99	10^{-4}	4	$\epsilon_0 - 4 \times 0.059$	
99.9	10^{-5}	5	$\epsilon_0 - 5 \times 0.059$	65
E.P. 100	10^{-7}	7	$\epsilon_0 - 7 \times 0.059$	1180
100.1	10^{-9}	9	$\epsilon_0 - 9 \times 0.059$	1180
101	10^{-10}	10	$\epsilon_0 - 10 \times 0.059$	65
110	10^{-11}	11	$\epsilon_0 - 11 \times 0.059$	

hydrogen-ion concentration, the third, pH ; the fourth, the potential of the electrode; and the fifth, $\frac{\Delta E}{\Delta c}$. This quotient represents the increment of the potential for a given addition of reagent. As is seen from the table, $\frac{\Delta E}{\Delta c}$ reaches a maximum at the equivalence point, which means that the second derivative at this point is equal to zero.

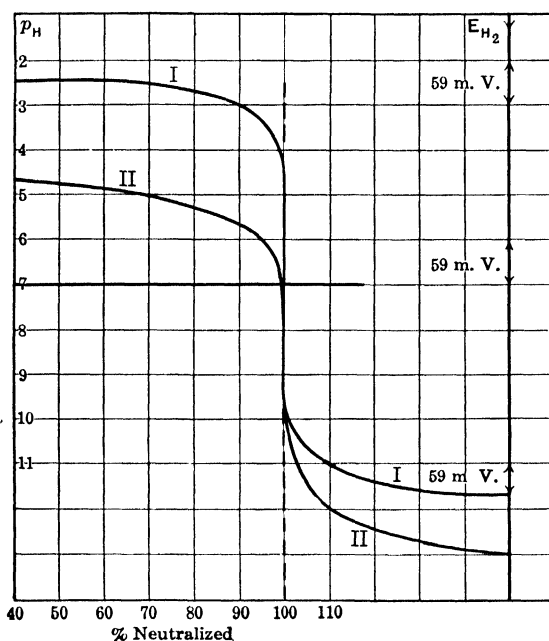

FIG. 19.—I. 0.01 N HCl + NaOH. II. 0.1 N acetic acid + NaOH.

The titration curve is given in Fig. 19.

The following table gives the titration curve of 0.1 N acetic acid with sodium hydroxide. (Cf. Fig. 19.)

Precipitation Reactions.—From the composition of the solution and the solubility product of the slightly soluble compound formed it is an easy matter to calculate the data for the con-

TITRATION OF 0.1 N ACETIC ACID WITH SODIUM HYDROXIDE $K_a = 1.8 \times 10^{-5}$

Per cent Neutralized	[H ⁺]	pH	E _{H₂}	$\frac{\Delta E}{\Delta c}$
0	1.35×10^{-3}	2.87	$\epsilon_0 - 2.87 \times 0.059 = \epsilon_0 - 0.170$	
9	1.6×10^{-4}	3.80	$\epsilon_0 - 3.80 \times 0.059 = \epsilon_0 - 0.224$	
50	1.8×10^{-5}	4.75	$\epsilon_0 - 4.75 \times 0.059 = \epsilon_0 - 0.280$	
90	2.0×10^{-6}	5.70	$\epsilon_0 - 5.70 \times 0.059 = \epsilon_0 - 0.336$	
99	1.8×10^{-7}	6.75	$\epsilon_0 - 6.75 \times 0.059 = \epsilon_0 - 0.398$	
99.8	3.6×10^{-8}	7.45	$\epsilon_0 - 7.45 \times 0.059 = \epsilon_0 - 0.440$	52
99.9	1.8×10^{-8}	7.75	$\epsilon_0 - 7.75 \times 0.059 = \epsilon_0 - 0.457$	170
E.P. 100	1.35×10^{-9}	8.87	$\epsilon_0 - 8.87 \times 0.059 = \epsilon_0 - 0.523$	660
100.1	10^{-10}	10	$\epsilon_0 - 10 \times 0.059 = \epsilon_0 - 0.590$	670
100.2	5×10^{-11}	10.3	$\epsilon_0 - 10.3 \times 0.059 = \epsilon_0 - 0.610$	200
101	10^{-11}	11	$\epsilon_0 - 11 \times 0.059 = \epsilon_0 - 0.649$	49

struction of the titration curve. As has been discussed on p. 115, at the equivalence point

$$[B^+] = [A^-] = \sqrt{S}.$$

With a known excess a of one of the two ions near the equivalence point, the solubility of BA cannot be neglected. Suppose it is equal to x , then we have

$$(a + x)x = S,$$

from which x can be calculated.

A simple example is given in the following table, where the data for the construction of the titration curve in the determination of 0.01 N silver nitrate with chloride are reported. The solubility product of silver chloride is approximated to 10^{-10} .

TITRATION OF 0.01 N SILVER NITRATE WITH CHLORIDE. $S_{\text{AgCl}} = 10^{-10}$

Per cent Reagent	$[\text{Ag}^+]$	p_{Ag}	E_{Ag}	$\frac{\Delta E}{\Delta c}$
0	10^{-2}	2.0	$\epsilon_{0\text{Ag}} - 2 \times 0.059$	
90	10^{-3}	3.0	$\epsilon_0 - 3 \times 0.059$	7
99	10^{-4}	4.0	$\epsilon_0 - 4 \times 0.059$	
99.9	1.6×10^{-5}	4.80	$\epsilon_0 - 4.80 \times 0.059$	52
E.P. 100	10^{-5}	5.00	$\epsilon_0 - 5.00 \times 0.059$	118
100.1	6.4×10^{-6}	5.20	$\epsilon_0 - 5.20 \times 0.059$	118
101	10^{-6}	6.0	$\epsilon_0 - 6.0 \times 0.059$	52
110	10^{-7}	7.0	$\epsilon_0 - 7.0 \times 0.059$	7

Oxidation-reduction Reactions.—In the following table the data for the construction of the titration curve of

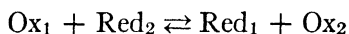

with the partial reactions:

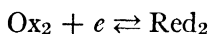
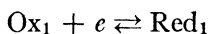

have been collected. The first column again gives the percentage of reagent added; the second the ratio of $\frac{[\text{Ox}_1]}{[\text{Red}_1]}$ until the equivalence point has been reached, and thereafter the ratio $\frac{[\text{Ox}_2]}{[\text{Red}_2]}$; the third column gives the potential during the titration.

3. The Detection of the Equivalence Point in Potentiometric Titrations.—If the potential of the “indicator electrode”

TITRATION OF AN OXIDANT Ox_1 WITH A REDUCTANT Red_2

Per Cent Reagent (Red_2) Added	Ratio $\frac{[Ox_1]}{[Red_1]}$	E
9	10	$\epsilon_0 + 1 \times 0.059$
50	1	ϵ_0
91	0.1	$\epsilon_0 - 1 \times 0.059$
99	0.01	$\epsilon_0 - 2 \times 0.059$
99.8	0.002	$\epsilon_0 - 2.7 \times 0.059$
99.9	0.001	$\epsilon_0 - 3 \times 0.059$
E.P. 100	$\sqrt{10} \frac{\epsilon_0 - \epsilon_0}{0.0591}$ Ratio $\frac{[Ox_2]}{[Red_2]}$	$\frac{\epsilon_{01} + \epsilon_{02}}{2}$
100.1	1000	$\epsilon_{02} + 3 \times 0.059$
100.2	500	$\epsilon_{02} + 2.7 \times 0.059$
101	100	$\epsilon_{02} + 2 \times 0.059$

is measured against some standard reference electrode, the change in E.M.F. of the cell is equal to the variation of the potential of the indicator electrode during the titration. The maximum change in potential occurs at, or, in case the titration curve is not symmetrical at both sides of the equivalence point, very close to the latter point. This means that the equivalence point is

located at the point where $\frac{\Delta E}{\Delta c}$ reaches a maximum, or its second

derivative is equal to zero. It is not necessary to plot all the readings in a graph, as the maximum may be read directly from the tabulated data. In the vicinity of the equivalence point the reagent is added drop by drop, and the readings are noted after the potential is constant after each addition. Then the change of $\frac{\Delta E}{\Delta c}$ for each drop of reagent added can be calculated, and its

maximum or the minimum of the second derivative can be found. The method yields highly accurate results within a fraction of a drop. The drop volume, of course, must be known

Titration to the Equivalence Potential.—If the potential of the indicator electrode is measured against a reference electrode the potential of which is equal to that of the indicator electrode at the equivalence point, the E.M.F. of the cell will be zero at this point. J. Pinkhof³ originally introduced this method, and it has been modified somewhat by W. D. Treadwell.⁴ When this

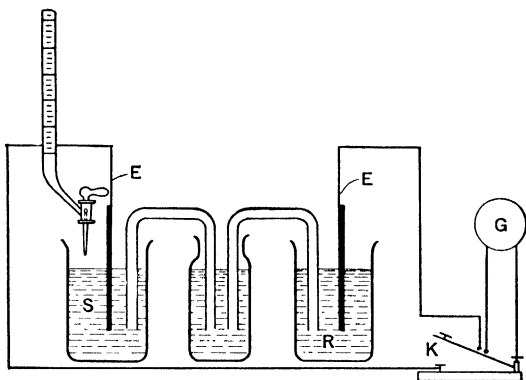

FIG. 21.—The Pinkhof system.

- S, solution to be tested.
- E, indicator electrode.
- R, reference electrode.
- G, galvanometer.
- K, key.

method is used a sudden reversal of polarity marks the end-point (Fig. 21). No potentiometer is necessary, and a galvanometer or capillary electrometer serves as indicating instrument. The deflection of the galvanometer decreases during the titration, is zero at the equivalence point, and it reverses after this point has been passed. According to the author's experience, the method has special advantages in titrations with the quinhydrone electrode. The latter is also used as reference electrode, and is placed in a buffer solution of the same pH as that of the solution at the equivalence point. A general disadvantage in the application of the Pinkhof system is that it is necessary to prepare a dif-

³ J. Pinkhof, Dissertation, Amsterdam, 1919.

⁴ W. D. Treadwell and L. Weiss, *Helv. Chim. Acta* **2**, 680 (1919).

ferent electrode for each type of titration. Therefore Erich Müller⁵ has modified the method. He uses the calomel electrode as a reference electrode, but switches into the circuit an E.M.F. which is just equal to that of the indicator electrode-reference electrode at the equivalence point. The reagent is added until the null-point instrument shows no deflection or changes the direction of the deflection. The value of the equivalence potential is found empirically; the potential where $\frac{\Delta E}{\Delta c}$ reaches a maximum corresponds to that at the end-point.

The Pinkhof method and its modifications have this advantage in common: the titration may be performed very quickly, and a result can be obtained in some minutes—this, however, very often at the cost of the accuracy of the titration. Usually we will find that especially near the equivalence point the potential does not become constant immediately after addition of the reagent. If the readings are made immediately after the addition of the reagent, there is no assurance that the equivalence point has been reached when the null-point instrument does not show a deflection. There are also certain other disadvantages. The Pinkhof (and Müller) system is only balanced at the equivalence point; therefore polarization may occur when readings are made during the titration. Finally, the equivalence potential is dependent upon conditions of the solution; the temperature and especially electrolytes have influence upon its magnitude. The latter is especially true in oxidation-reduction reactions, where the hydrogen ions often have a great influence upon the normal potential of the system. For these reasons the Pinkhof method and its modifications cannot be recommended for highly accurate work, though they may have some advantages in certain practical cases and routine analyses.

Bimetallic Systems.—Noble metals like platinum or gold act as indicators for the electron activity of the oxidation-reduction system in the solution. If now we could find an electrode material which would not respond to a change of an electron

⁵ Erich Müller, *Die elektrometrische Massanalyse*, Dresden, Third Edition.

activity in the solution, it would be an ideal electrode for the use in potentiometric titrations. If the indicator electrode and the "inert" electrode are placed in the same solution, then the change of the E.M.F. of such an element would be exactly the same as the variation in potential of the indicator electrode during the titration. Such a system, which eliminates the use of a standard half-cell, is called a *bimetallic electrode system*.

Recently Kamienski⁶ claimed that a silicon carbide electrode ("Carborundum") actually behaves like such an inert electrode. If this proves to be true, it would be an ideal material for a bimetallic electrode system in all kinds of titrations.

Most electrodes so far studied do not behave in the ideal way as discussed above. Some metals like tungsten-platinum alloy when placed in a "well-buffered" mixture of an oxidant and a reductant attain the same potential as a platinum or gold electrode. However, when placed in a pure solution of the oxidant or reductant they show a marked difference in potential against platinum; this difference depends very much upon the pre treatment of the metal. If now such a pair of electrodes like platinum and palladium are placed in a ferrous iron solution, they will show a certain potential difference. Upon titration with an oxidizing agent this difference falls rapidly to zero, and remains thus until just before the equivalence point. A larger change in the potential difference gives warning that the abrupt and characteristic break in potential at the end-point will soon be reached. After the end point has been passed, the potential difference will gradually drop to zero again. The difference in behavior between the two electrodes is explained by the fact that one (platinum) approaches equilibrium very quickly in solutions of pure reductant or oxidant, whereas the other is very slow in the extreme cases where the oxidation-reduction system is not buffered. After a long time of waiting, however, both electrodes will reach the same state of equilibrium, and the potential difference between the two will be zero. A bimetallic system may be obtained in an artificial way by using two similar elec-

⁶ Kamienski, *Z. physik. Chem.* **145**, 48 (1929).

trodes (like platinum) which are slightly polarized. Originally Hostetter and Roberts⁷ observed that a palladium wire shows almost no change in potential during a ferrous iron titration with dichromate. Later the bimetallic system was studied systematically by H. H. Willard and F. Fenwick,⁸ who made important applications.⁹ An elegant application of polarized electrodes has been made by Foulk and Bawden¹⁰ in their so-called dead-stop end point.

Differential Titrations.—The principle is the following: Suppose two similar indicator electrodes are placed in the solution to be titrated, one of which can be protected from the bulk of the solution by placing a cap over it, which can be moved up and down. If both electrodes are in the solution, they will attain the same potential and the E.M.F. is equal to zero. Some reagent is added, during which one electrode is protected by the cap. Then the two electrodes are in contact with solutions of various composition and there will be an E.M.F. between them. This, however, will be very small until we arrive at the vicinity of the equivalence point. Here an abrupt change in potential occurs at the unprotected electrode. Actually the differential titration can be carried out according to the above principle. After each addition of reagent the E.M.F. is read, the cap lifted, and the solution is made homogeneous by stirring. The E.M.F. will drop to zero. Then the cap is placed over one of the electrodes, reagent is added again, etc. A maximum difference in E.M.F. is observed at the equivalence point. The method was originally suggested by D. C. Cox¹¹ in a less practical form. It has been developed by MacInnes and co-workers¹² according to the above

⁷ Hostetter and Roberts, *J. Am. Chem. Soc.* **41**, 1337 (1919).

⁸ H. H. Willard and F. Fenwick, *J. Am. Chem. Soc.* **44**, 2504, 2516 (1922); **45**, 84, 623, 645, 715, 928, 933 (1923); van Name and Fenwick, **47**, 9, 19 (1925).

⁹ For the characteristics of various combinations, *cf.* also Furman and Wilson, *J. Am. Chem. Soc.* **50**, 277 (1928).

¹⁰ Foulk and Bawden, *J. Am. Chem. Soc.* **48**, 2045 (1926).

¹¹ D. C. Cox, *J. Am. Chem. Soc.* **47**, 2138 (1925).

¹² MacInnes and Jones, *J. Am. Chem. Soc.*, **48**, 283 (1926; MacInnes, *Z. physik. Chem.* **130**, 217 (1927); MacInnes and Dole, *J. Am. Chem. Soc.* **51**, 1119 (1929). MacInnes and I. A. Cowperthwaite, *J. Am. Chem. Soc.*, **53**, 555 (1931).

principle. An illustration of the MacInnes electrode with cap is given in Fig. 22. MacInnes and his collaborators showed that the differential method is capable of high precision (of the order of 0.002 per cent!).

A convenient form of differential system has been given by Erich Müller (Fig. 23). A trace of the solution is withdrawn into a capillary tube, in which one electrode is mounted.

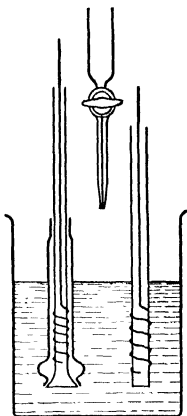

FIG. 22.—MacInnes and Jones' apparatus.

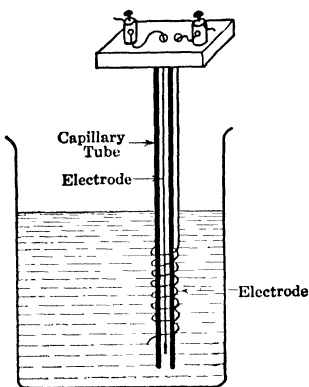

FIG. 23.—Muller's apparatus.

4. Special Determinations.—Any reaction which can be made the basis of an ordinary titration can be useful for potentiometric purposes, if a *suitable indicator electrode is available*. Therefore a great number of potentiometric titrations have been described in the literature, a review of which is given by Kolthoff and Furman.¹³ The electrodes suitable for *pH* measurements can be used in all kinds of acidity and basicity determinations (*cf.* p. 96). With regard to the determination and titration of metallic ions, we are limited in our choice. Metals in the electromotive series above hydrogen are easily oxidized and polarized, and they are useless in potentiometric titrations. They can be used for the measurements of metallic ion concentrations, if special precautions against oxidation and polarization are

¹³ Kolthoff and Furman, *Potentiometric Titrations*, 2nd Ed. (1931).

taken. In general only noble metals like silver and mercury are suitable for potentiometric titrations. They also serve as anion indicators, if the anion forms a slightly soluble or stable complex compound with the metal.

$$[\text{Ag}^+][\text{Cl}^-] = S$$

$$[\text{Cl}^-] = \frac{S}{[\text{Ag}^+]}$$

and

$$[\text{Ag}^+] = \frac{S}{[\text{Cl}^-]}$$

The potential of the silver electrode is given by:

$$E = \epsilon_0 + 0.0591 \log [\text{Ag}^+].$$

In a suspension of silver chloride with an excess of alkali chloride

$$[\text{Ag}^+] = \frac{S}{[\text{Cl}^-]},$$

$$\begin{aligned} E &= \epsilon_0 + 0.0591 \log [\text{Ag}^+] = \epsilon_0 + 0.0591 \log \frac{S}{[\text{Cl}^-]} \\ &= \epsilon_0' - 0.0591 \log [\text{Cl}^-]. \end{aligned}$$

Under these conditions, therefore, the silver electrode behaves like a chloride-ion electrode.

In oxidation-reduction reactions a bright platinum gauze or wire will serve as an indicator electrode, as a rule. Very often the electrode is slow to attain its constant potential, especially near the equivalence point. Under these conditions it is often desirable to perform the titration at a higher temperature. The potentiometric method is of especial advantage in cases where we have two or more oxidizing substances present in the solution. If one system has an oxidation-reduction potential of a different order of magnitude from the second, the system with the highest normal potential will be reduced first. After complete reduction a jump in potential occurs, and a second break occurs after reduction of the second system.

Another general advantage of potentiometric titrations is that no visual error can be made in the detection of the end-point, and a high degree of precision can be reached. Especially in the titrations of colored systems, or of those for which we have no suitable visual indicator, the potentiometric methods have great importance.

PROBLEMS IN POTENTIOMETRY

1. Define the normal hydrogen electrode; the normal silver electrode, the normal ferric-ferrous iron electrode.

2. At 25° a hydrogen electrode against some standard half-cell has an E.M.F. of -0.6000 volt. The normal hydrogen electrode against the half-cell has an E.M.F. of -0.3000 at the same temperature. What is the pH of the solution if the barometric pressure during the measurement is 740 m.m., and the vapor tension of the solution 24 mm. mercury?

3. What is the E.M.F. of the cell; hydrogen electrode 0.1 N HCl – hydrogen electrode 0.001 N HCl, at 25° , assuming that: (a) the ion concentration is identical with the ion activity; (b) the activity coefficient of the hydrogen ions in 0.1 N HCl is 0.84 and in 0.001 N HCl 0.97 .

4. At 25° the potential difference between the hydrogen electrode (hydrogen pressure one atmosphere) and the quinhydrone electrode both placed in the same solution is 0.6990 volt. If the quinhydrone electrode is considered as a hydrogen electrode of low hydrogen pressure (show how), what will be its pressure?

5. Show that the potential difference between an antimony-antimonious oxide electrode is a simple function of the pH of the solution.

6. The potential of the normal calomel electrode (against the normal hydrogen electrode) is 0.2847 volt, of the 0.1 N calomel electrode 0.3376 volt. What is the E.M.F. of a cell N calomel – 0.1 N calomel electrode? What would you expect if the activity of the chloride ions in both electrodes were the same as the corresponding potassium chloride concentrations?

7. The pH of the following solutions has to be measured: 0.1 molar boric acid; 0.1 molar acetic acid; 0.1 molar copper sulfate, 0.01 molar lead chloride; 0.1 molar ferric chloride; 0.1 molar morphinchloride; 0.1 molar sodium sulfide; 0.1 molar ferrous sulphate, 0.1 molar zinc sulfate, 0.1 molar iodine in potassium iodide. Specify which of the following electrodes can be used: Hydrogen electrode; quinhydrone electrode, antimony electrode, glass electrode, and give a reasonable justification of your choice.

8. What is the equilibrium constant K of the reaction:

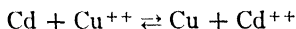

$$\frac{[\text{Cd}^{++}]}{[\text{Cu}^{++}]} = K$$

if both metallic copper and cadmium are present in the solid state? The normal potential of copper is $+0.522$ volt, of cadmium -0.40 volt.

9. What is the E.M.F. of an element:



assuming that the activities of the ions are the same as their concentrations.

10. A mixture of potassium ferrocyanide and potassium ferricyanide is diluted 100 times. How does the oxidation-reduction potential change: (a) if the ratio of the activity coefficients of the ferro- and ferricyanide ions remains unchanged? (b) If this ratio increases 30 times?

11. Give a quantitative expression of the oxidation-reduction potential of the following systems and show what the influence of the hydrogen-ion concentration is:

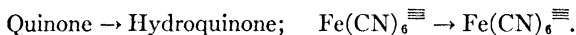
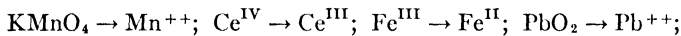

12. Hydrogen fluoride forms a stable complex with ferric ions. What is the effect of HF upon the oxidation-reduction potential of a mixture of ferrous-ferric iron?

13. Calculate the change of the potential of the hydrogen electrode in the titration of 0.1 molar lactic acid with sodium hydroxide, assuming that the volume does not change during the titration. Compute the data after addition of 0 per cent, 9 per cent, 50 per cent, 91 per cent, 99 per cent, 99.8 per cent, 99.9 per cent, 100 per cent, 100.1 per cent, 100.2 per cent, 101 per cent, of the equivalent amount of sodium hydroxide. What is $\frac{\Delta E}{\Delta c}$ near and at the equivalence point?

$$K_a = 1.5 \times 10^{-4}. \quad K_w = 10^{-14}. \quad t = 25^\circ \text{C}.$$

14. Answer the same problem for the titration of 0.1 molar and 0.001 molar hydrochloric acid.

15. After addition of 90 c.c. 0.1 N sodium chloride to 100 c.c. 0.1 N silver nitrate the potential of the silver electrode against some standard half-cell is 0.4000 volt. (Ag electrode is positive.) After addition of 110 c.c. it is 0.0814 volt (25°). Calculate the solubility product of silver chloride, assuming that activities and concentrations of the ions are identical.

16. One-tenth N silver nitrate is titrated with potassium bromide. Assume that the volume does not change during the titration. How much is the potential of the silver electrode after 0 per cent, 90 per cent, 99 per cent, 99.8 per cent, 99.9 per cent, 100.1 per cent, 100.2 per cent, 101 per cent addition of the equivalent amount of bromide? Solubility product of silver bromide is 5×10^{-13} .

17. A solution of ceric cerium is titrated with a ferrous sulfate solution. What is the oxidation-reduction potential after addition of 9 per cent, 50 per cent, 91 per cent, 99 per cent, 99.8 per cent, 99.9 per cent, 100 per cent, 100.1 per cent, 100.2 per cent, 101 per cent and 110 per cent of the equivalent amount of ferrous iron solution?

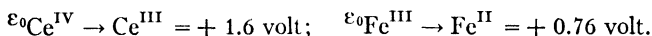

PART III
CONDUCTOMETRIC TITRATIONS

CHAPTER VIII

CONDUCTOMETRIC TITRATIONS¹

1. The Principles of Conductometric Titrations.—Electrometric titrations can be divided into two groups: the potentiometric and the conductometric. The theory underlying these two groups is entirely different. The theory of potentiometric titrations is very similar to that of ordinary titrations, in so far as the change of the potential of a suitable electrode is a linear function of the change of the logarithm of the ion concentration or the logarithm of the ratio of concentration of oxidant to reductant in the system to be titrated. A large jump in potential at the equivalence point means a sharp color change of a suitable indicator; and the titration to a definite potential is comparable with an ordinary titration in which the reagent is added until the indicator has assumed a definite color. Therefore, the electrode in a potentiometric titration can be more or less compared to a specific indicator for the ion or oxidation-reduction system to be titrated.

In conductometric work, on the other hand, all ions present contribute to the electrical conductivity of the solution. If an electrolyte is added to a solution of another electrolyte without changing the volume to any appreciable extent, the conductivity

¹ The author expresses his appreciation to Dr. H. E. Howe, editor of Industrial Engineering Chemistry, for allowing him to use part of the original manuscript in the preparation of this chapter. Part of this chapter has been published in Industrial Engineering Chemistry, Analytical Edition, 2, 225 (1930).

increases in so far as the electrolytes do not react with each other. If an ion of one electrolyte unites with an ion of the other to form a slightly dissociated or slightly soluble substance or if it changes the total ion concentration by an oxidation or reduction process, then the conductivity of the solution may change in three different ways, before the equivalence point has been reached: (1) the conductance decreases. (2) The conductance remains unchanged. (3) The conductance increases.

The conductance of various ions for the electric current is different. It is usually expressed by the mobility λ of the ion. The equivalent conductivity Λ of an electrolyte BA is equal to the sum of the mobilities of both ions:

$$\Lambda_{BA} = \lambda_{B^+} + \lambda_{A^-}.$$

The equivalent conductance Λ is the conductance in reciprocal ohms of a solution containing one gram equivalent of solute when placed between electrodes which are 1 cm. apart; hence it is equal to the specific conductance divided by the concentration, the latter being expressed in equivalents per cubic centimeter.

$$\Lambda = \frac{\kappa}{c} 1000.$$

κ denotes the specific conductance of the solution; c the concentration expressed in equivalents per liter. The equivalent conductance, in other words, is the specific conductance the solution would have if the electrolyte were present in a concentration of one equivalent per cubic centimeter. On account of the interionic effect the equivalent conductance or the mobility of the ions decreases with increasing electrolyte content of the solution. The values reach a maximum at infinite dilution. In dilute solutions the following relation holds between the equivalent conductance Λ_c at a concentration c and Λ_∞ :

$$\Lambda_c = \Lambda_\infty - A\sqrt{c}.$$

A is a constant which is different for various electrolytes. The mobility of the ions increases very much with the temperature,

as their migration velocity increases. The increase of the mobility of most ions is 2 to 2.5 per cent for 1° C. increase in temperature, for hydrogen ions the change is only 1.5 per cent, for hydroxyl ions 1.8 per cent per 1° C. change in temperature.

In the following table the mobilities of some ions at 25° and at infinite dilution are reported. The data are taken from reliable studies reported in the literature.

MOBILITY OF SOME IONS AT 25° AT INFINITE DILUTION

Li.....	41 7	OH	193
Na.....	50 8	Cl	75 8
Ag.....	63 4	NO ₃	70 9
K.....	74 8	HCO ₃	47
NH ₄	74 9	IO ₃	39 6
H	350	CHC ₃ OO.....	40 8
$\frac{1}{2}$ Ba.....	65.2	$\frac{1}{2}$ CO ₃	70
$\frac{1}{2}$ Ca.	61	$\frac{1}{2}$ C ₂ O ₄	73 5
$\frac{1}{2}$ Mg	55 0	$\frac{1}{2}$ SO ₄	80 0
$\frac{1}{2}$ Pb.....	71.0	$\frac{1}{3}$ Fe(CN) ₆ [≡]	97.3
$\frac{1}{2}$ Tl	76 0	$\frac{1}{4}$ Fe(CN) ₆ [≡]	100 8
$\frac{1}{2}$ Ni	53 6		
$\frac{1}{2}$ Fe ⁺⁺	54		
$\frac{1}{3}$ Fe ⁺⁺⁺	68 4		

Let us now consider how the conductance of a solution of a strong electrolyte BA will change upon the addition of a reagent CD, assuming that the cation B⁺ reacts with the anion D⁻ of the reagent. If the product of reaction is slightly dissociated or insoluble, the reaction may be expressed by the equation:

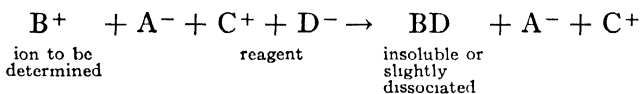

Therefore, by the reaction between B⁺ and D⁻ ions, the B ions during the titration are replaced by C ions.

Case 1.—The mobility of the B ions (λ_B) is greater than λ_C ; the conductance of the BA solution decreases upon the addition of the reagent CD. This case generally occurs in the titration of strong acid with strong bases or in the reverse titration. The hydrogen and hydroxyl ions distinguish themselves from the

other ions by a much larger mobility. (See table on mobility of ions.)

Case 2.— λ_B and λ_C are equal. The conductance remains unchanged by the addition of CD until the equivalence point has been reached. This case is met with in most precipitation reactions. In the titration of silver nitrate with barium chloride, the barium ion takes the place of the silver ion, and as both ions have about the same mobility, the conductivity does not change during the reaction. If instead of barium chloride, sodium chloride is used as a reagent, the conductivity decreases slightly, as λ_{Ag} is greater than λ_{Na} . On the other hand, with potassium chloride as a reagent, the conductivity increases slightly because λ_{Ag} is smaller than λ_K .

Case 3.—The conductivity increases from the beginning of the titration if a slightly dissociated substance is titrated and the reaction product is a strong electrolyte. This case in general occurs in the neutralization of a weak acid with a strong base or a weak base with a strong acid. In any case, the conductivity increases after the equivalence point has been reached, at least if the reagent is a strong electrolyte.

In a conductometric titration the conductance is measured after addition of successive amounts of reagent. The points thus obtained are plotted to give a graph which as a rule consists of two straight lines intersecting at the equivalence point. Therefore, the latter is found in a graphical way. In contrast to any other type of titration method, measurements near the equivalence point have no special significance. As a matter of fact, the values found near the equivalence point are often worthless in the construction of the two straight lines, on account of the fact that the reaction product by its dissociation or solubility contributes to the conductivity of the solution, whereas we should know the data where the conductivity caused by the reaction product itself is negligibly small. In reactions which can be made the basis of a conductometric titration, the latter is always the case, when there is an excess of ion to be titrated or of reagent. Near the equivalence point the points often do not lie on one of

the two straight lines, but the conductivity found is higher than the corresponding ones on the straight lines (titration of very weak acids and bases: hydrolysis; precipitation reactions). (Cf. Figs. 34 and 35.)

The point mentioned, that a marked hydrolysis, solubility or dissociation of the reaction product does not affect the accuracy of the method very much, makes the application of *conductometric titrations possible to those cases where other titration methods fail to give results*. This will be shown by several examples in the following review.

On the other hand, it is emphasized here that the conductometric method can be much less generally applied than the ordinary or potentiometric one, on account of the fact that large amounts of foreign electrolytes, which do not take part in the reaction, affect the accuracy greatly. The relative change of the conductivity during the reaction and upon addition of excess of reagent mainly determines the accuracy, and this change is decreased by the presence of foreign electrolytes. Of course one must not infer from this that the conductometric method is rendered impossible by the presence of foreign electrolytes; if precision methods are used in the measurement of the conductivity and the titration is carried out in a thermostat, the method can be applied in the presence of relatively large amounts of indifferent electrolytes. This, however, is reached at the cost of the simplicity of the method.

2. The Performance of Conductometric Titrations.—For details about the measurement of electrical conductance and the significance of the cell constant the reader is referred to textbooks on electrochemistry.

An ordinary conductometric titration can be carried out in a relatively short time (ten minutes or longer).

A titration cell as given in Figs. 24 or 25 can be used. Fig. 24 gives the more or less classical model of Dutoit. The two platinum electrodes are in a vertical position in order to prevent the deposit of a precipitate in precipitation reactions. The electrodes are welded to a platinum wire, the latter being

sealed in the glass and making electrolytic contact outside the vessel in a mercury pocket. The cell is placed in a block of wood or paraffin. Successive portions of the reagent are added from a microburette, which can be connected in some way to a reservoir containing a supply of the standard solution. It is

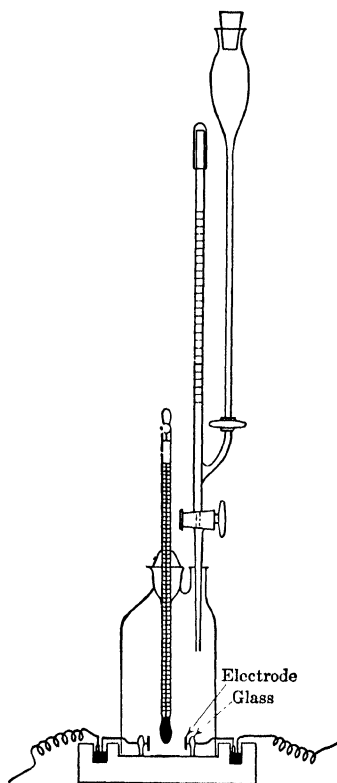

FIG. 24.—Titration vessel.

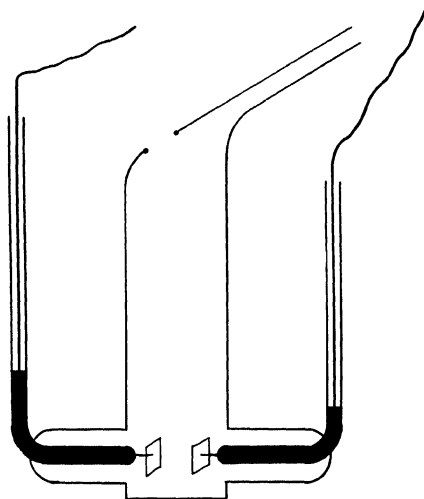

FIG. 25.—Titration vessel with handle.

recommended to use a reagent which is at least ten to twenty times more concentrated than the solution to be titrated. The cell in Fig. 24 also contains a thermometer divided into 0.1 degrees. A change in temperature during the titration will affect the result very much, as the conductivity increases greatly with increasing temperature (for most salts about 2 to 2.5 per cent for

1°). In cases where the heat of reaction is fairly high, irregularities in the conductivity curve may occur on account of the temperature effect. As a rule, however, the heat effect during a titration is very small. After the addition of reagent the cell is shaken to secure homogeneous mixing; in this manipulation one has to be careful not to warm the solution by taking the whole cell in his hand. Convenient for the shaking is a glass handle attached to the cell, as in Fig. 25. If work is done with solutions of quite different conductance, one should have a few titration cells with different cell constants adapted to the special purpose. The accuracy in the location of the end-point in conductometric titrations as a rule is not larger than 0.5 to 1 per cent. For precise work it is recommended that the titration be performed in a thermostat.

It is not necessary to know the absolute values of the specific conductivity of the solution during the titration; the reciprocal value of the resistance can be plotted, as it is proportional to the conductance.

The conductance can be measured according to the classical method of the Wheatstone bridge, using a telephone for the detection of the minimum. Though this method is quite satisfactory, it has a practical disadvantage, namely, that one needs a quiet room, undisturbed by noises. This requirement might prevent a more general application of conductometric titrations. Fortunately, at the present time the telephone can be replaced by other instruments or arrangements so that the minimum can be detected in a visual way.

In the first place, the Leeds and Northrup alternating current galvanometer may be mentioned. The equipment provides means for utilizing current from a 60-cycle 110-volt A.C. circuit, and the galvanometer is especially recommended for conductometric titration work. It is not suitable for highly precise measurements, and even in titrations some difficulties may arise by polarization of the electrodes and the heating of the solution in the cell. If these difficulties are overcome, it seems that the A.C. galvanometer will furnish us with the simplest apparatus

for detection of the point of balance on the Wheatstone bridge.

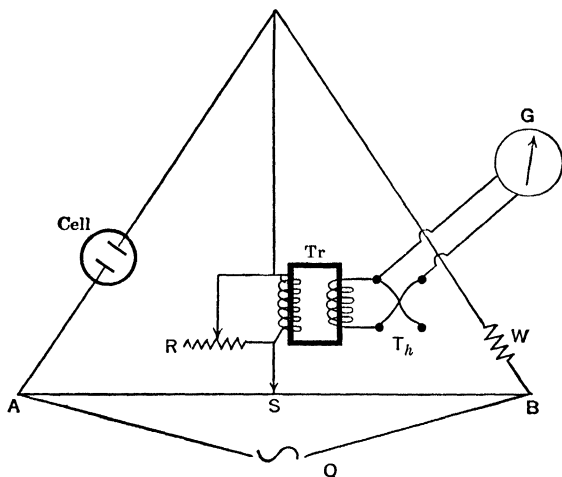

FIG. 26.—Apparatus using thermo-cross.

Of other methods recommended, those advocated by G. Jander

and O. Pfundt² will be briefly discussed. They use a thermo-cross (Fig. 26) or a special commutator (crystal detector) (Fig. 27) as rectifier. In Fig. 26 the thermo-cross, T_h , and the transformer are placed in the Wheatstone bridge instead of the telephone. The thermo-cross consists of a couple of constantan and iron wire kept in a small box to protect it from atmospheric disturbances. If a current

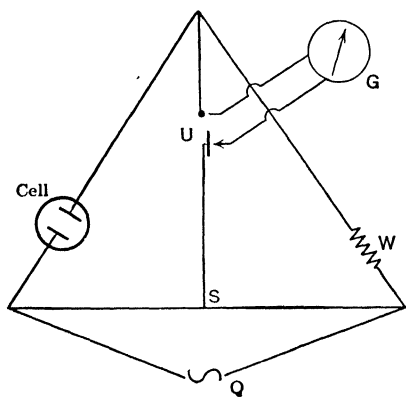

FIG. 27.—Apparatus using crystal detector.

thermo current is developed, and the galvanometer G gives a

² G. Jander and O. Pfundt, *Die visuelle Leitfähigkeitstiteration*, Stuttgart, 1929, 46 pp. Verlag Enke.

deflection. In order to prevent the direct current from passing through the conductivity cell, the transformer, T, is placed in the circuit. R is a resistance by means of which the sensitivity of the system can be regulated. W is a known resistance and AB a slide wire as used in the ordinary method. The apparatus can be used in different ways; many details have to be considered, for which the reader is referred to the work of Jander and Pfundt. Simpler to manipulate is the system in Fig. 27, where U represents the rectifier. It may be mentioned that T. Callan and S. Horrobin³ a few years ago described a similar arrangement in which they used a silicon carbide detector (from the Carborundum Company) as a rectifier; also W. D. Treadwell and S. Janett⁴ made use of a commutating device to avoid the use of the telephone.

3. Application of Conductometric Titrations to Acid-Base Reactions.—In this section a condensed review of the application of conductometric titrations to acid-base reactions will be given. For details the reader is referred to a monograph of I. M. Kolthoff.⁵

Strong Acids with Strong Bases.—In the following graphs the ordinate represents the conductivity and the abscissa the volume of reagent added. In the titration of a strong acid with a strong base (or *vice versa*) a sharp break in the conductivity occurs at the equivalence point. Theoretically the minimum should not occur exactly at the equivalence point where pH is 7, but slightly at the alkaline side, as the mobility of the hydrogen ions is much larger than that of the hydroxyl ions. From a simple differential equation it can be computed that the minimum occurs at a hydroxyl-ion concentration of 1.4×10^{-7} . The difference between this and the neutral point is so small that it cannot be determined experimentally.

It is of interest to note that the shape of the conductivity

³ T. Callan and S. Horrobin, *J. Soc. Chem. Ind.* **47**, T 329 (1928).

⁴ W. D. Treadwell and S. Janett, *Helv. Chim. Act.* **6**, 734 (1923).

⁵ I. M. Kolthoff, *Konduktometrische Titraktionen*, Dresden, 1923, Verlag Steinkopff.

line is independent of the dilution. Extremely dilute solutions of strong acids or strong bases, of the order of 0.0001 N, can be titrated with the same accuracy as more concentrated solutions, if care is taken to exclude carbon dioxide.

On the whole, the application of the conductometric titration in this case has only practical significance when the solution has a dark color so that the indicator method fails to give results.

Intermediate Weak Acids and Bases.—The shape of the neutralization curve depends upon the concentration and the ionization constant of the acid or base. By neutralization of the dissociated part of the acid, the conductivity will drop, and on account of the formation of its salt, which behaves as a strong

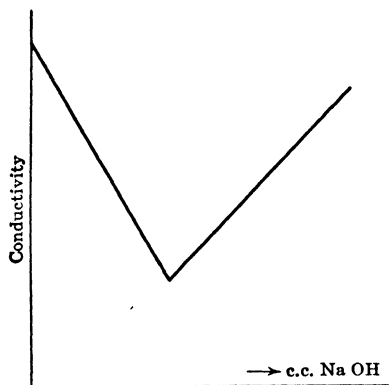

FIG. 28.—Strong acid and strong base.

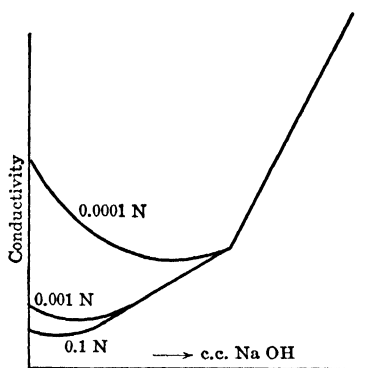

FIG. 29.—Acetic acid with sodium hydroxide.

electrolyte, the conductance increases. The practical neutralization curve is obtained by adding the figures of the “acid-depression curve” to those of the “salt line.” The more strongly the acid is ionized, the more its neutralization curve approaches that of a strong acid, and the less it is ionized the more it behaves like an extremely weak acid; the latter case will be discussed later.

In Fig. 29 the neutralization curves are given for the neutralization of 0.1 N, 0.001 N, and 0.0001 N acetic acid, respectively. From the above it is evident that in many cases a

flat minimum will occur in the neutralization curve. Its location can be calculated from the ionization constant, the concentration, and the mobilities of the ions present in the system. The minimum itself has no analytical significance, though it may give us an indication of the magnitude of the ionization constant of an acid, which may be of importance in unknown cases. If the acid is relatively highly ionized, the neutralization line will give a curve up to the equivalence point, and it is hard to find with any degree of accuracy the point of intersection of the neutralization curve with the sodium hydroxide line, the latter being the straight line found after addition of an excess of base.

Such a case occurs, for example, in the neutralization of 0.01 N salicylic acid as is shown in Fig. 30. An analysis of the curve shows that the equivalence point is found at the point of intersection of the salt line and sodium hydroxide line.

The former can be determined in an experimental way. Suppose 100 c.c. 0.01 N salicylic acid are titrated with 0.5 N sodium hydroxide so that the sodium hydroxide line can be drawn. In order to find the shape of the salt line a second determination is made in which 100 c.c. of water instead of dilute acid is taken and successive amounts of 0.5 N sodium salicylate of exactly the same strength as the sodium hydroxide are added. From the latter data, the salt line can be constructed and the equivalence point can be found with an accuracy of at least 1 per cent.

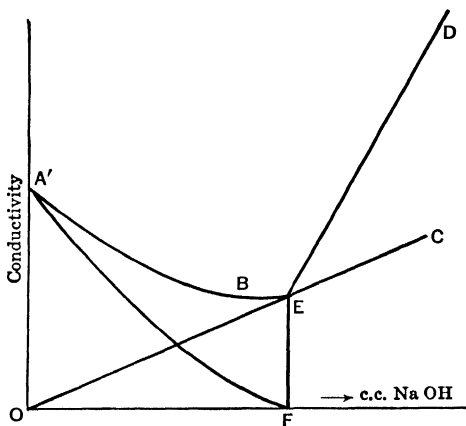

FIG. 30.—Neutralization of 0.01 N salicylic acid with sodium hydroxide.

- ABE, neutralization curve.
- ED, sodium hydroxide line.
- OEC, salt line.
- AF, acid depression curve.

If the dissociation of the acid during the neutralization is less than in the above case, the last part of the neutralization curve before the equivalence point will be a straight line. Under these conditions, the point of intersection can be found by a single titration. This is the case if the ionization constant of the acid is smaller than about 5×10^{-4} in the titration of 0.1 N solutions, smaller than 5×10^{-5} for 0.01 N solutions, and smaller than 5×10^{-6} for 0.001 N solutions.

Very Weak Acids and Bases.—The initial conductivity is very small, and during the neutralization the conductivity increases according to the salt line. On account of the hydrolysis of the salt formed, the experimental data near the equivalence point are higher than the corresponding points on the salt and sodium hydroxide line; therefore, in the construction of the two lines, points should be taken at such a distance from the equivalence point that the hydrolysis is negligibly small and the points can then be combined to give straight lines. If the acid is extremely weak (e.g., hydrogen peroxide) the hydrolysis is so large that the titration does not yield useful results. For the titration of 0.1 N solutions, the ionization constant should be larger than about 10^{-10} , for 0.01 N solutions larger than 10^{-9} , for 0.001 N solutions larger than 10^{-8} . These figures have no exact significance; they only give the order of magnitude of the ionization constant at which useful results can still be obtained.

From the above we see that the conductometric titration can be applied where the potentiometric or ordinary method does not give satisfactory results.

In Fig. 31 neutralization curves of 0.1 N and 0.01 N boric acid with sodium hydroxide are given. Several applications can be made. Hydroxy benzenes, like phenol and resorcinol, can be titrated very nicely. A systematic study has shown that resorcinol and hydroquinol behave like dibasic acids; pyrocatechol, on the other hand, as a monobasic acid. The trivalent phenols, pyrogallol and phloroglucinol, behave like dibasic acids. The method has been applied to the titration of nitrophenols, phenolphthalein, and other weak acids whose salts are colored.

Phenolphthalein in 50 per cent alcohol behaves like a dibasic acid, a break occurring after the neutralization of the carboxyl and phenol groups. The conductometric method should be very useful to organic chemists in cases where they want to know quantitatively the acid or basic character of a colored substance. It also can be recommended for the determination of the equivalent weight of amino acids and polypeptides, and the acid or base combining power of proteins. A practical application of the method can be made in the determination of vanillin in vanillin sugar. The aromatic substance is extracted with alcohol and titrated as a strong base.

What has been said for very weak acids holds also for very weak bases. Aniline, hexamethylenetetramine, and pyridine can be titrated accurately with hydrochloric acid.

Neutralization of Weak Acids with Weak Bases.—Though in analytical work one always uses a strong acid or a strong base as a reagent, the above case has practical significance, e.g., when a pure ammonium salt of a weak acid has to be prepared or when a weak acid must be titrated in the presence of an ammonium salt or the salt of another weak base.

Fig. 32 gives the titration lines of 0.1 N and 0.01 N acetic acid, respectively, with ammonia. The neutralization curve up to the equivalence point is about the same as found with sodium hydroxide, since both sodium and ammonium acetate are strong electrolytes. After the equivalence point has been reached, an excess of ammonia leaves the conductivity practically unchanged, as the dissociation of the weak base is depressed by the presence

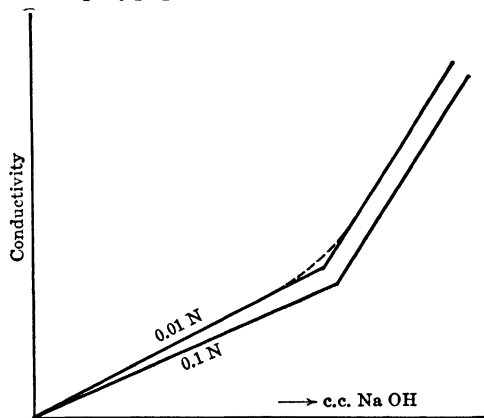

FIG. 31.—Neutralization of boric acid with sodium hydroxide.

of the ammonium salt. On account of the hydrolysis, the values near the equivalence point are somewhat lower than the corresponding points on the straight lines. If the acid or base to be titrated is extremely weak (e.g., boric acid with ammonia), no straight lines can be constructed on account of the strong hydrolysis.

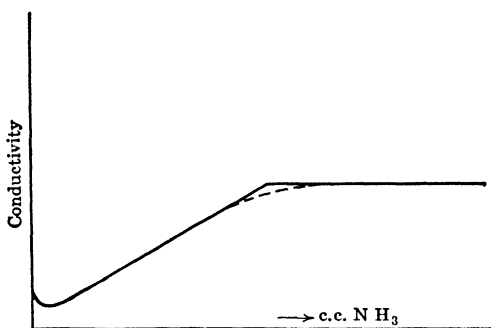

FIG. 32.—Neutralization of 0.01 N acetic acid with ammonia.

corresponding points on the straight lines. If the acid or base to be titrated is extremely weak (e.g., boric acid with ammonia), no straight lines can be constructed on account of the strong hydrolysis.

Mixtures of a Strong and Weak Acid.—Here

again the conductometric method can be advantageously applied, whereas the ordinary or potentiometric method does not yield satisfactory results. The above case is a combination of two which have been discussed before. First, the strong acid is neutralized and the conductivity drops, following a straight line. Near the first equivalence point, the weaker acid will be neutralized and the conductivity will soon increase according to the salt line of the weak acid. In Fig. 33, the change in conductivity during the neutralization of a mixture of 10 c.c. 0.01 N hydrochloric acid, 10 c.c. 0.01 N acetic acid, and 10 c.c. of water with 1 N sodium hydroxide is given. The case has practical significance,

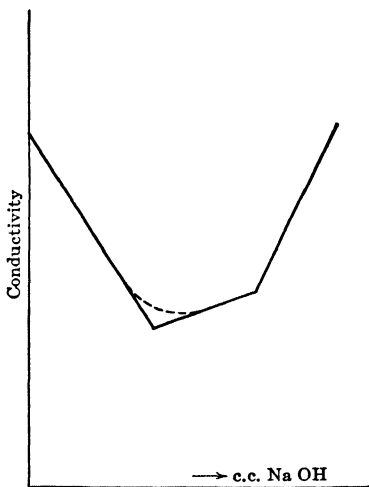

FIG. 33.—Mixture of 0.01 N hydrochloric and 0.01 N acetic acid.

e.g., for the determination of traces of mineral acids in vinegar. Recently the author, in collaboration with Mr. T. Kameda,

has made another application for the determination of the purity of sulfonphthaleins. The sulfonic group behaves as a strong acid and is first neutralized; after the first break, the conductivity increases, and after neutralization of the phenolic group a second break occurs.

The application of the conductometric method to the titration of a mixture of two weak acids with quite different ionization constants (like acetic and boric acid) does not have much practical significance, for a sharp break never occurs after the neutralization of the stronger acid. The difference in mobility of the anions of the two acids determines the sharpness of the break, and as this difference always is very small, the angle between the two salt lines will be very obtuse. Therefore, as a rule, the first equivalence point cannot be found with a high degree of accuracy.

Replacement Titrations.—When a salt of a weak acid is titrated with a strong acid, the anion of the weak acid is replaced by that of the stronger one and the weak acid itself is liberated in the undissociated form. Similarly, the addition of a strong base replaces the weak base in a salt of the latter.

Many important applications of these replacement reactions can be made to conductometric titrations; especially those cases are important which do not yield successful results with the indicator or potentiometric method.

If, for example, hydrochloric acid is added to a solution of sodium acetate, the acetate ion is replaced by the chloride ion. The conductivity increases slightly on account of the fact that λ_{Cl} is a little greater than λ_{acetate} . After all the acetic acid has been liberated, continued addition of hydrochloric acid gives rise to a strong increase in conductance. Fig. 34 gives the conductance lines in the titration of 0.01 N sodium acetate with N hydrochloric acid. On account of the dissociation of the acetic acid, the experimental figures near the equivalence point are somewhat higher than the corresponding ones on the straight lines. If the ionization constant of the liberated acid is smaller than about 5×10^{-5} , 0.01 N solutions of its salt can be titrated accurately. For 0.1 N solutions, the constant may even be as large as

5×10^{-4} . Ethyl alcohol decreases the ionization of weak acids, and in the presence of enough alcohol even salts of stronger acids than those indicated above can be titrated.

The method furnishes a simple means for the evaluation of salts of weak acids, such as acetates, benzoates, succinates, etc. Similarly, it can be applied to the determination of ammonia in ammonium salts by titration with sodium hydroxide. A rapid determination of the ammonium content of fertilizers can be made in this way.

In this review, a condensed summary has been given of the application of conductometric titrations to acid-base reactions.

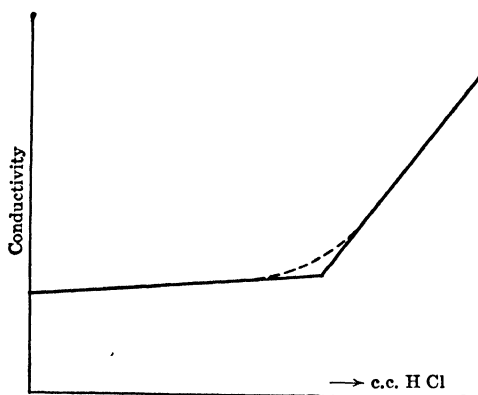

FIG. 34.—Titration of 0.01 N sodium acetate with hydrochloric acid.

For details concerning the combination of different cases and specific cases (carbon dioxide, phosphoric acid, alkaloids, phenols, salts of heavy metals, etc.) the reader is referred to the monograph by Kolthoff (*loc. cit.*, p. 141).

From all that has been said, it may be inferred that the significance of conductometric titrations should be more generally recognized. They often furnish us information which could otherwise only be obtained by elaborate work.

4. Application of Conductometric Titrations to Precipitation and Complex Formation Analysis.—A reaction usually can be made the basis of a conductometric titration if the reaction product is a slightly soluble substance or a stable complex. The usefulness and accuracy are mainly dependent upon the following facts:

- (a) errors in the determination of the conductance data;
- (b) solubility of the precipitate or stability of the complex;

- (c) speed of formation of the precipitate;
- (d) constant composition (purity) of the precipitate.

(a) The same error in the determination may affect the accuracy of the titration in different ways. This depends upon the acuteness of the angle between the precipitation line (line combining the conductance data during the precipitation) and the reagent line (line giving the conductance data with excess of reagent). The more acute the angle is, the more accurate the result. If the angle is very obtuse, a small error in the conductance data can cause a large deviation. Therefore, one should always endeavor to choose such experimental conditions that the angle is as acute as possible. The following rules should be borne in mind:

(1) The smaller the mobility of the ion which replaces the reacting ion, the more accurate will be the result. If a silver salt is titrated with lithium chloride, the conductivity decreases during the precipitation and increases after the equivalence point. If hydrochloric acid were used as a reagent, the conductivity would increase from the beginning of the titration, and the angle between the precipitation and reagent line would be very obtuse. Therefore, generally it is recommended to titrate cations with lithium salts and anions with acetates.

(2) The larger the mobility of the anion of the reagent which reacts with the cations to be determined (or *vice versa*) the more acute is the angle. For example, it is more advantageous to titrate silver salts with sodium chloride than with sodium nitroprusside, as the mobility of the chloride ion is larger than that of the nitroprusside.

(3) The titration of a slightly ionized salt does not give good results, since the conductivity increases relatively much from the start of the determination.

(4) As has been mentioned in the beginning of this chapter, the accuracy of a conductometric titration always suffers from the presence of electrolytes that do not take part in the reaction.

(b) On account of the solubility of the precipitate, the experi-

mental figures near the equivalence point deviate from the straight line, as is shown in Fig. 35. AEDFC gives the experimental curve. If the solubility of the precipitate were negligibly small, the conductivity at the equivalence point would be equal to BG. By an excess of the ion which is precipitated or an excess of reagent, the solubility is depressed, and if the latter is not too large, it usually is possible to construct the precipitation and reagent line by joining points on AE and FC.

It can be shown that 0.1 N solutions can still be titrated if the solubility of the precipitate formed is less than about 0.005 N;

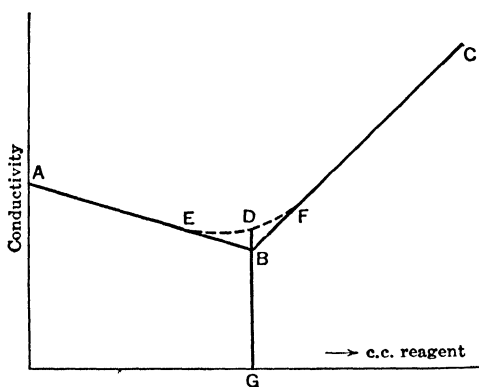

FIG. 35.—Precipitation Line.

(uni-univalent electrolyte); for 0.01 N solutions the solubility should be smaller than about 0.0005 N.

(c) The formation of a microcrystalline precipitate is usually a time reaction. After addition of a small amount of reagent, the conductance does not immediately become

constant; one must wait for some time. Seeding the solution with the precipitate itself has a favorable effect, though in the titration of very dilute solutions even this does not overcome the difficulty. Quite generally it is much better to add enough alcohol to make its concentration about 30–40 per cent. The speed of formation of the precipitate then becomes much larger, and, furthermore, another advantage is gained, the solubility of most slightly soluble substances is materially reduced by alcohol. Of course, one should realize that on addition of alcohol to a solution the temperature rises; therefore, before the titration is started, the mixture should be cooled to room temperature.

(d) If the precipitate has strong adsorbent properties, the

method does not yield successful results. So, for example, the titration of heavy metals with sodium sulfide or ferrocyanide cannot be recommended on account of the inconstant composition of the precipitate. If a microcrystalline precipitate like barium sulfate or calcium oxalate is formed, occlusion phenomena may play a part. Finally, it may be mentioned that under certain conditions the surface conductance of the solid precipitate may affect the results.

Many precipitation or complex reactions have been made the basis of a conductometric titration. A short summary of most satisfactory cases is given below. For details, the reader is referred to Kolthoff's monograph (*loc. cit.*, p. 141).

Silver nitrate as reagent: chloride, bromide, iodide, cyanide, thiocyanate, chromate; also iodide in presence of chloride in ammoniacal medium.

Mercuric perchlorate as reagent (complex formation): chloride, bromide, iodide, cyanide, thiocyanate, formate, acetate, and its homologues.

Lead nitrate as reagent: iodide, ferrocyanide, ferricyanate, sulfate, sulfite, thiosulfate, pyrophosphate, oxalate, tartrate, succinate, benzoate.

Barium acetate (or *barium chloride*) as reagent: sulfate, chromate, carbonate, pyrophosphate, oxalate, tartrate, citrate.

Sodium perchlorate as reagent: Potassium⁶ at 0°; it is not accurate, according to the author's experience.

Lithium sulfate as reagent: barium, strontium, calcium, lead.

Sodium chromate as reagent: Barium, lead, silver.

Lithium oxalate as reagent: silver, lead, copper, cadmium, nickel, cobalt, manganese, zinc, ferro, calcium, barium, strontium, magnesium and strong acids.

⁶ G. Jander and O. Pfundt, *Z. anal. Chem.* **71**, 417 (1927).

PROBLEMS

1. 0.001 N hydrochloric acid is titrated with sodium hydroxide. Calculate the conductance of the solution after addition of 0 per cent, 20 per cent, 40 per cent, 60 per cent, 80 per cent, 100 per cent, 120 per cent, 140 per cent, 180 per cent, of the equivalent amount of base, assuming that the volume does not change during the titration. $\lambda_{\text{H}} = 350$; $\lambda_{\text{OH}} = 193$; $\lambda_{\text{Na}} = 51$; $\lambda_{\text{Cl}} = 76$. Plot the results in a graph.

2. 0.1 N acetic acid is titrated with sodium hydroxide. Calculate the data of the neutralization curve (see problem 1), and plot the results in a graph. Ionization constant acetic acid is 1.8×10^{-5} ; $\lambda_{\text{H}} = 350$; $\lambda_{\text{OH}} = 193$; $\lambda_{\text{Na}} = 51$; $\lambda_{\text{acetate}} = 41$.

3. The same problem as 2, but instead of 0.1 N acetic acid 0.0001 N acetic acid is taken.

4. A 0.01 N solution of ammonium chloride is titrated with sodium hydroxide. Calculate the conductance of the solution after addition of 0 per cent, 20 per cent, 40 per cent, 60 per cent, 80 per cent, 100 per cent, 120 per cent, 140 per cent, 160 per cent, 180 per cent, of the equivalent amount of base, assuming that the volume does not change during the titration. Plot the results in a graph. Ionization constant of ammonia is 1.8×10^{-5} ; $\lambda_{\text{NH}_4} = 75$; $\lambda_{\text{Cl}} = 76$; $\lambda_{\text{Na}} = 51$; $\lambda_{\text{OH}} = 193$.

5. A 0.1 N solution of silver nitrate is titrated with lithium chloride. Calculate the conductance of the solution after addition of 0 per cent, 20 per cent, 40 per cent, 60 per cent, 80 per cent, 100 per cent, 120 per cent, 140 per cent, 160 per cent, 180 per cent, of the equivalent amount of chloride, assuming that the volume does not change during the titration. Plot the results in a graph. Solubility product of silver chloride is 0.10×10^{-10} ; $\lambda_{\text{Ag}} = 63$; $\lambda_{\text{NO}_3} = 71$; $\lambda_{\text{Li}} = 42$; $\lambda_{\text{Cl}} = 76$.

6. The same problem as 5, but calculate for 0.001 N silver nitrate solution. (Solubility of silver chloride.)

PRACTICAL COURSE

INDICATORS

Required: Volumetric flasks; pipettes, burettes; also some pipettes of 1 c.c. divided in 0.01 c.c.

1. Prepare 0.1 per cent solutions of the following indicators (*cf.* p. 30); tropeolin 00; methylorange; methylred sodium; thymolblue; bromphenolblue; *p*-nitrophenol; bromcresolgreen; chlorphenolred; bromthymolblue; phenolred; neutralred; and phenolphthalein.
2. Prepare a complete set of buffer mixtures (pH 2 – 10), according to Clark (*cf.* p. 38); and citrate buffer mixtures (pH 2 – 6), according to Kolthoff and Vleeschhouwer (see p. 39).
3. Determine color-change interval of various indicators and compare figures with those in the literature (*cf.* p. 31).
4. Determine the pH of 0.05 molar monopotassium phosphate; 0.05 molar monopotassium citrate; 0.05 molar monopotassium phthalate; 0.1 molar ammonium chloride (sublimated product); 0.1 molar sodium bicarbonate; tap water; ordinary distilled water (*cf.* p. 52); conductivity water (*cf.* p. 52).
5. Determine the pH of a buffer solution with pH around 6 with *p*-nitrophenol as indicator according to the method of Michaelis (*cf.* p. 47).
6. Determine the pH of a colored and of a slightly turbid solution, using the comparator (see p. 50).
7. Determine the neutralization curve of some acid or base.

POTENTIOMETRY

1. Platinize the hydrogen electrode (*cf.* p. 98); prepare salt bridges (*cf.* p. 93); prepare 15 g. quinhydrone (*cf.* p. 103); prepare a saturated calomel electrode (*cf.* p. 93).
2. Measure the pH of a mixture of 0.01 N HCl + 0.09 N KCl with the hydrogen electrode against the quinhydrone electrode in the same mixture, and against the saturated calomel electrode. If the correct value (2.04; *cf.* equations, p. 97) is found, determine the pH of 0.05 molar monopotassium phosphate, potassium biphthalate, borax, and sodium carbonate.
3. Add to a buffer solution of Clark of pH 5.0 so much KCl that its concentration is 0.5 molar. Measure the pH with the hydrogen electrode

and also colorimetrically (salt error indicators). Use methylred and bromcresolgreen as indicators.

4. Measure the pH of some buffer solutions with the quinhydrone electrode.
5. Titrate 0.1 N hydrochloric acid with 0.1 N NaOH,
0.1 N hydrochloric acid with 0.1 N borax,
0.1 N acetic acid with 0.1 N NaOH,
using the hydrogen, quinhydrone or antimony electrode (*cf.* p. 96;
p. 101; p. 110).
Plot the results and the pH values in a graph and indicate the color-change intervals of some suitable indicators.
6. Titrate 0.1 N nitric acid with sodium hydroxide using the air electrode (p. 107).
7. A silver electrode for potentiometric titrations is prepared by electroplating a platinum gauze electrode in a potassium-silver cyanide solution at low current density, until a bright layer of silver is deposited. The electrode is thoroughly washed.
Titrate 0.1 N KCl + 0.1 N AgNO₃,
0.1 N KI + 0.1 N AgNO₃.
(Use salt bridge filled with ammonium nitrate or potassium sulfate.)
8. For oxidation-reduction titrations use a bright platinum wire or gauze electrode.
Titrate: 0.1 N ferrous iron with 0.1 N potassium dichromate in acid
medium;
0.1 N potassium iodide in dilute sulfuric acid with 0.1 N potassium permanganate.

CONDUCTOMETRIC TITRATIONS

Platinize the electrodes of a conductometric titration cell and titrate:

- 100 c.c. 0.01 N HCl with 0.5 N sodium hydroxide.
- 100 c.c. 0.01 N acetic acid with 0.5 N sodium hydroxide.
- 100 c.c. 0.001 N acetic acid with 0.05 N sodium hydroxide.
- 100 c.c. 0.1 molar boric acid with 0.5 N sodium hydroxide.
- 100 c.c. 0.01 N sodium acetate with 0.5 N hydrochloric acid.
- 100 c.c. 0.01 N sodium chloride with 0.5 N silver nitrate.
- 100 c.c. of a mixture of 0.01 N NaCl and 0.01 N KI.
- The same, but in 1 N ammonia.

LOGARITHM TABLES

Natural Numbers.											PROPORTIONAL PARTS.									
	0	1	2	3	4	5	6	7	8	9	1	2	3	4	5	6	7	8	9	
10	0000	0043	0086	0128	0170	0212	0253	0294	0334	0374	4	8	12	17	21	25	29	33	37	
11	0414	0453	0492	0531	0569	0607	0645	0682	0719	0755	4	8	11	15	19	23	26	30	34	
12	0792	0828	0864	0899	0934	0969	1004	1038	1072	1106	3	7	10	14	17	21	24	28	31	
13	1139	1173	1206	1239	1271	1303	1335	1367	1399	1430	3	6	10	13	16	19	23	26	29	
14	1461	1492	1523	1553	1584	1614	1644	1673	1703	1732	3	6	9	12	15	18	21	24	27	
15	1761	1790	1818	1847	1875	1903	1931	1959	1987	2014	3	6	8	11	14	17	20	22	25	
16	2041	2068	2095	2122	2148	2175	2201	2227	2253	2279	3	5	8	11	13	16	18	21	24	
17	2304	2330	2355	2380	2405	2430	2455	2480	2504	2529	2	5	7	10	12	15	17	20	22	
18	2553	2577	2601	2625	2648	2672	2695	2718	2742	2765	2	5	7	9	12	14	16	19	21	
19	2788	2810	2833	2856	2878	2900	2923	2945	2967	2989	2	4	7	9	11	13	16	18	20	
20	3010	3032	3054	3075	3096	3118	3139	3160	3181	3201	2	4	6	8	11	13	15	17	19	
21	3222	3243	3263	3284	3304	3324	3345	3365	3385	3404	2	4	6	8	10	12	14	16	18	
22	3424	3444	3464	3483	3502	3522	3541	3560	3579	3598	2	4	6	8	10	12	14	15	17	
23	3617	3636	3655	3674	3692	3711	3729	3747	3766	3784	2	4	6	7	9	11	13	15	17	
24	3802	3820	3838	3856	3874	3892	3909	3927	3945	3962	2	4	5	7	9	11	12	14	16	
25	3979	3997	4014	4031	4048	4065	4082	4099	4116	4133	2	3	5	7	9	10	12	14	15	
26	4150	4166	4183	4200	4216	4232	4249	4265	4281	4298	2	3	5	7	8	10	11	13	15	
27	4314	4330	4346	4362	4378	4393	4409	4425	4440	4456	2	3	5	6	8	9	11	13	14	
28	4472	4487	4502	4518	4533	4548	4564	4579	4594	4600	2	3	5	6	8	9	11	12	14	
29	4624	4639	4654	4669	4683	4698	4713	4728	4742	4757	1	3	4	6	7	9	10	12	13	
30	4771	4786	4800	4814	4829	4843	4857	4871	4886	4900	1	3	4	6	7	9	10	11	13	
31	4914	4928	4942	4955	4969	4983	4997	5011	5024	5038	1	3	4	6	7	8	10	11	12	
32	5051	5065	5079	5092	5105	5119	5132	5145	5159	5172	1	3	4	5	7	8	9	11	12	
33	5185	5198	5211	5224	5237	5250	5263	5276	5289	5302	1	3	4	5	6	8	9	10	12	
34	5315	5328	5340	5353	5366	5378	5391	5403	5416	5428	1	3	4	5	6	8	9	10	11	
35	5441	5453	5465	5478	5490	5502	5514	5527	5539	5551	1	2	4	5	6	7	9	10	11	
36	5563	5575	5587	5599	5611	5623	5635	5647	5658	5670	1	2	4	5	6	7	8	10	11	
37	5682	5694	5705	5717	5729	5740	5752	5763	5775	5786	1	2	3	5	6	7	8	9	10	
38	5798	5809	5821	5832	5843	5855	5866	5877	5888	5899	1	2	3	5	6	7	8	9	10	
39	5911	5922	5933	5944	5955	5966	5977	5988	5999	6010	1	2	3	4	5	7	8	9	10	
40	6021	6031	6042	6053	6064	6075	6085	6096	6107	6117	1	2	3	4	5	6	8	9	10	
41	6128	6138	6149	6160	6170	6180	6191	6201	6212	6222	1	2	3	4	5	6	7	8	9	
42	6232	6243	6253	6263	6274	6284	6294	6304	6314	6325	1	2	3	4	5	6	7	8	9	
43	6335	6345	6355	6365	6375	6385	6395	6405	6415	6425	1	2	3	4	5	6	7	8	9	
44	6435	6444	6454	6464	6474	6484	6493	6503	6513	6522	1	2	3	4	5	6	7	8	9	
45	6532	6542	6551	6561	6571	6580	6590	6599	6609	6618	1	2	3	4	5	6	7	8	9	
46	6628	6637	6646	6656	6665	6675	6684	6693	6702	6712	1	2	3	4	5	6	7	7	8	
47	6721	6730	6739	6749	6758	6767	6776	6785	6794	6803	1	2	3	4	5	5	6	7	8	
48	6812	6821	6830	6839	6848	6857	6866	6875	6884	6893	1	2	3	4	4	5	6	7	8	
49	6902	6911	6920	6928	6937	6946	6955	6964	6972	6981	1	2	3	4	4	5	6	7	8	
50	6990	6998	7007	7016	7024	7033	7042	7050	7059	7067	1	2	3	3	4	5	6	7	8	
51	7076	7084	7093	7101	7110	7118	7126	7135	7143	7152	1	2	3	3	4	5	6	7	8	
52	7160	7168	7177	7185	7193	7202	7210	7218	7226	7235	1	2	2	3	4	5	6	7	7	
53	7243	7251	7259	7267	7275	7284	7292	7300	7308	7316	1	2	2	3	4	5	6	7	7	
54	7324	7332	7340	7348	7356	7364	7372	7380	7388	7396	1	2	2	3	4	5	6	6	7	

Natural Numbers.										PROPORTIONAL PARTS.										
	0	1	2	3	4	5	6	7	8	9	1	2	3	4	5	6	7	8	9	
55	7404	7412	7419	7427	7435	7443	7451	7459	7466	7474	I	2	2	3	4	5	5	6	7	
56	7482	7490	7497	7505	7513	7520	7528	7536	7543	7551	I	2	2	3	4	5	5	6	7	
57	7559	7566	7574	7582	7589	7597	7604	7612	7619	7627	I	2	2	3	4	5	5	6	7	
58	7634	7642	7649	7657	7664	7672	7679	7686	7694	7701	I	1	2	2	3	4	4	5	6	7
59	7709	7716	7723	7731	7738	7745	7752	7760	7767	7774	I	1	2	2	3	4	4	5	6	7
60	7782	7789	7796	7803	7810	7818	7825	7832	7839	7846	I	1	2	2	3	4	4	5	6	6
61	7853	7860	7868	7875	7882	7889	7896	7903	7910	7917	I	1	2	2	3	4	4	5	6	6
62	7924	7931	7938	7945	7952	7959	7966	7973	7980	7987	I	1	2	2	3	4	4	5	6	6
63	7993	8000	8007	8014	8021	8028	8035	8041	8048	8055	I	1	2	2	3	4	4	5	6	6
64	8062	8069	8075	8082	8089	8096	8102	8109	8116	8122	I	1	2	2	3	4	4	5	6	6
65	8129	8136	8142	8149	8156	8162	8169	8176	8182	8189	I	1	2	2	3	4	4	5	6	6
66	8195	8202	8209	8215	8222	8228	8235	8241	8248	8254	I	1	2	2	3	4	4	5	6	6
67	8261	8267	8274	8280	8287	8293	8299	8306	8312	8319	I	1	2	2	3	4	4	5	6	6
68	8325	8331	8338	8344	8351	8357	8363	8370	8376	8382	I	1	2	2	3	4	4	5	6	6
69	8388	8395	8401	8407	8414	8420	8426	8432	8439	8445	I	1	2	2	3	4	4	5	6	6
70	8451	8457	8463	8470	8476	8482	8488	8494	8500	8506	I	1	2	2	3	4	4	5	6	6
71	8513	8519	8525	8531	8537	8543	8549	8555	8561	8567	I	1	2	2	3	4	4	5	6	6
72	8573	8579	8585	8591	8597	8603	8609	8615	8621	8627	I	1	2	2	3	4	4	5	6	6
73	8633	8639	8645	8651	8657	8663	8669	8675	8681	8686	I	1	2	2	3	4	4	5	6	6
74	8692	8698	8704	8710	8716	8722	8727	8733	8739	8745	I	1	2	2	3	4	4	5	6	6
75	8751	8756	8762	8768	8774	8779	8785	8791	8797	8802	I	1	2	2	3	4	4	5	6	6
76	8808	8814	8820	8825	8831	8837	8842	8848	8854	8859	I	1	2	2	3	4	4	5	6	6
77	8865	8871	8876	8882	8887	8893	8899	8904	8910	8915	I	1	2	2	3	4	4	5	6	6
78	8921	8927	8932	8938	8943	8949	8954	8960	8965	8971	I	1	2	2	3	4	4	5	6	6
79	8976	8982	8987	8993	8998	9004	9009	9015	9020	9025	I	1	2	2	3	4	4	5	6	6
80	9031	9036	9042	9047	9053	9058	9063	9069	9074	9079	I	1	2	2	3	4	4	5	6	6
81	9085	9090	9096	9101	9106	9112	9117	9122	9128	9133	I	1	2	2	3	4	4	5	6	6
82	9138	9143	9149	9154	9159	9165	9170	9175	9180	9186	I	1	2	2	3	4	4	5	6	6
83	9191	9196	9201	9206	9212	9217	9222	9227	9232	9238	I	1	2	2	3	4	4	5	6	6
84	9243	9248	9253	9258	9263	9269	9274	9279	9284	9289	I	1	2	2	3	4	4	5	6	6
85	9294	9299	9304	9309	9315	9320	9325	9330	9335	9340	I	1	2	2	3	4	4	5	6	6
86	9345	9350	9355	9360	9365	9370	9375	9380	9385	9390	I	1	2	2	3	4	4	5	6	6
87	9395	9400	9405	9410	9415	9420	9425	9430	9435	9440	O	1	2	2	3	4	4	5	6	6
88	9445	9450	9455	9460	9465	9469	9474	9479	9484	9489	O	1	2	2	3	4	4	5	6	6
89	9494	9499	9504	9509	9513	9518	9523	9528	9533	9538	O	1	2	2	3	4	4	5	6	6
90	9542	9547	9552	9557	9562	9566	9571	9576	9581	9586	O	1	2	2	3	4	4	5	6	6
91	9590	9595	9600	9605	9609	9614	9619	9624	9628	9633	O	1	2	2	3	4	4	5	6	6
92	9638	9643	9647	9652	9657	9661	9666	9671	9675	9680	O	1	2	2	3	4	4	5	6	6
93	9685	9689	9694	9699	9703	9708	9713	9717	9722	9727	O	1	2	2	3	4	4	5	6	6
94	9731	9736	9741	9745	9750	9754	9759	9763	9768	9773	O	1	2	2	3	4	4	5	6	6
95	9777	9782	9786	9791	9795	9800	9805	9809	9814	9818	O	1	2	2	3	4	4	5	6	6
96	9823	9827	9832	9836	9841	9845	9850	9854	9859	9863	O	1	2	2	3	4	4	5	6	6
97	9868	9872	9877	9881	9886	9890	9894	9899	9903	9908	O	1	2	2	3	4	4	5	6	6
98	9912	9917	9921	9926	9930	9934	9939	9943	9948	9952	O	1	2	2	3	4	4	5	6	6
99	9956	9961	9965	9969	9974	9978	9983	9987	9991	9996	O	1	2	2	3	4	4	5	6	6

Log.											PROPORTIONAL PARTS.								
	0	1	2	3	4	5	6	7	8	9	1	2	3	4	5	6	7	8	9
.00	1000	1002	1005	1007	1009	1012	1014	1016	1019	1021	o	o	1	1	1	1	2	2	2
.01	1023	1026	1028	1030	1033	1035	1038	1040	1042	1045	o	o	1	1	1	1	2	2	2
.02	1047	1050	1052	1054	1057	1059	1062	1064	1067	1069	o	o	1	1	1	1	2	2	2
.03	1072	1074	1076	1079	1081	1084	1086	1089	1091	1094	o	o	1	1	1	1	2	2	2
.04	1096	1099	1102	1104	1107	1109	1112	1114	1117	1119	o	1	1	1	1	2	2	2	2
.05	1122	1125	1127	1130	1132	1135	1138	1140	1143	1146	o	1	1	1	1	2	2	2	2
.06	1148	1151	1153	1156	1159	1161	1164	1167	1169	1172	o	1	1	1	1	2	2	2	2
.07	1175	1178	1180	1183	1186	1189	1191	1194	1197	1199	o	1	1	1	1	2	2	2	2
.08	1202	1205	1208	1211	1213	1216	1219	1222	1225	1227	o	1	1	1	1	2	2	2	3
.09	1230	1233	1236	1239	1242	1245	1247	1250	1253	1256	o	1	1	1	1	2	2	2	3
.10	1259	1262	1265	1268	1271	1274	1276	1279	1282	1285	o	1	1	1	1	2	2	2	3
.11	1288	1291	1294	1297	1300	1303	1306	1309	1312	1315	o	1	1	1	2	2	2	2	3
.12	1318	1321	1324	1327	1330	1334	1337	1340	1343	1346	o	1	1	1	2	2	2	2	3
.13	1349	1352	1355	1358	1361	1365	1368	1371	1374	1377	o	1	1	1	2	2	2	3	3
.14	1380	1384	1387	1390	1393	1396	1400	1403	1406	1409	o	1	1	1	2	2	2	3	3
.15	1413	1416	1419	1422	1426	1429	1432	1435	1439	1442	o	1	1	1	2	2	2	3	3
.16	1445	1449	1452	1455	1459	1462	1466	1469	1472	1476	o	1	1	1	2	2	2	3	3
.17	1479	1483	1486	1489	1493	1496	1500	1503	1507	1510	o	1	1	1	2	2	2	3	3
.18	1514	1517	1521	1524	1528	1531	1535	1538	1542	1545	o	1	1	1	2	2	2	3	3
.19	1549	1552	1556	1560	1563	1567	1570	1574	1578	1581	o	1	1	1	2	2	3	3	3
.20	1585	1589	1592	1596	1600	1603	1607	1611	1614	1618	o	1	1	1	2	2	3	3	3
.21	1622	1626	1629	1633	1637	1641	1644	1648	1652	1656	o	1	1	2	2	2	3	3	3
.22	1660	1663	1667	1671	1675	1679	1683	1687	1690	1694	o	1	1	2	2	2	3	3	3
.23	1698	1702	1706	1710	1714	1718	1722	1726	1730	1734	o	1	1	2	2	2	3	3	4
.24	1738	1742	1746	1750	1754	1758	1762	1766	1770	1774	o	1	1	2	2	2	3	3	4
.25	1778	1782	1786	1791	1795	1799	1803	1807	1811	1816	o	1	1	2	2	2	3	3	4
.26	1820	1824	1828	1832	1837	1841	1845	1849	1854	1858	o	1	1	2	2	3	3	3	4
.27	1862	1866	1871	1875	1879	1884	1888	1892	1897	1901	o	1	1	2	2	3	3	3	4
.28	1905	1910	1914	1919	1923	1928	1932	1936	1941	1945	o	1	1	2	2	3	3	4	4
.29	1950	1954	1959	1963	1968	1972	1977	1982	1986	1991	o	1	1	2	2	3	3	4	4
.30	1995	2000	2004	2009	2014	2018	2023	2028	2032	2037	o	1	1	2	2	3	3	4	4
.31	2042	2046	2051	2056	2061	2065	2070	2075	2080	2084	o	1	1	2	2	3	3	4	4
.32	2089	2094	2099	2104	2109	2113	2118	2123	2128	2133	o	1	1	2	2	3	3	4	4
.33	2138	2143	2148	2153	2158	2163	2168	2173	2178	2183	o	1	1	2	2	3	3	4	4
.34	2188	2193	2198	2203	2208	2213	2218	2223	2228	2234	1	2	2	2	3	3	4	4	5
.35	2239	2244	2249	2254	2259	2265	2270	2275	2280	2286	1	2	2	2	3	3	4	4	5
.36	2291	2296	2301	2307	2312	2317	2323	2328	2333	2339	1	2	2	2	3	3	4	4	5
.37	2344	2350	2355	2360	2366	2371	2377	2382	2388	2393	1	2	2	2	3	3	4	4	5
.38	2399	2404	2410	2415	2421	2427	2432	2438	2443	2449	1	2	2	2	3	3	4	4	5
.39	2455	2460	2466	2472	2477	2483	2489	2495	2500	2506	1	2	2	2	3	3	4	4	5
.40	2512	2518	2523	2529	2535	2541	2547	2553	2559	2564	1	2	2	2	3	3	4	4	5
.41	2570	2576	2582	2588	2594	2600	2606	2612	2618	2624	1	2	2	2	3	3	4	4	5
.42	2630	2636	2642	2649	2655	2661	2667	2673	2679	2685	1	2	2	2	3	3	4	4	5
.43	2692	2698	2704	2710	2716	2723	2729	2735	2742	2748	1	2	2	2	3	3	4	4	5
.44	2754	2761	2767	2773	2780	2786	2793	2799	2805	2812	1	2	2	2	3	3	4	4	5
.45	2818	2825	2831	2838	2844	2851	2858	2864	2871	2877	1	2	2	2	3	3	4	4	5
.46	2884	2891	2897	2904	2911	2917	2924	2931	2938	2944	1	2	2	2	3	3	4	4	5
.47	2951	2958	2965	2972	2979	2985	2992	2999	3006	3013	1	2	2	2	3	3	4	4	5
.48	3020	3027	3034	3041	3048	3055	3062	3069	3076	3083	1	2	2	2	3	3	4	4	5
.49	3090	3097	3105	3112	3119	3126	3133	3141	3148	3155	1	2	2	2	3	3	4	4	5

Log.											PROPORTIONAL PARTS.										
	0	1	2	3	4	5	6	7	8	9	1	2	3	4	5	6	7	8	9		
.50	3162	3170	3177	3184	3192	3199	3206	3214	3221	3228	1	1	2	3	4	4	5	6	7		
.51	3236	3243	3251	3258	3266	3273	3281	3289	3296	3304	1	2	2	3	4	4	5	5	6	7	
.52	3311	3319	3327	3334	3342	3350	3357	3365	3373	3381	1	2	2	3	4	4	5	5	6	7	
.53	3388	3396	3404	3412	3420	3428	3436	3443	3451	3459	1	2	2	3	4	4	5	5	6	7	
.54	3467	3475	3483	3491	3499	3508	3516	3524	3532	3540	1	2	2	3	4	4	5	5	6	7	
.55	3548	3556	3565	3573	3581	3589	3597	3606	3614	3622	1	2	2	3	4	4	5	5	6	7	7
.56	3631	3639	3648	3656	3664	3673	3681	3690	3698	3707	1	2	3	3	4	4	5	5	6	7	8
.57	3715	3724	3733	3741	3750	3758	3767	3776	3784	3793	1	2	3	3	4	4	5	5	6	7	8
.58	3802	3811	3819	3828	3837	3846	3855	3864	3873	3882	1	2	3	4	4	5	5	6	7	8	8
.59	3890	3899	3908	3917	3926	3936	3945	3954	3963	3972	1	2	3	4	5	5	6	6	7	8	8
.60	3981	3990	3999	4009	4018	4027	4036	4046	4055	4064	1	2	3	4	5	6	6	7	8	8	8
.61	4074	4083	4093	4102	4111	4121	4130	4140	4150	4159	1	2	3	4	5	6	7	8	9	9	9
.62	4169	4178	4188	4198	4207	4217	4227	4236	4246	4256	1	2	3	4	5	6	7	8	9	9	9
.63	4266	4276	4285	4295	4305	4315	4325	4335	4345	4355	1	2	3	4	5	6	7	8	9	9	9
.64	4365	4375	4385	4395	4406	4416	4426	4436	4446	4457	1	2	3	4	5	6	7	8	9	9	9
.65	4467	4477	4487	4498	4508	4519	4529	4539	4550	4560	1	2	3	4	5	6	7	8	9	9	9
.66	4571	4581	4592	4603	4613	4624	4634	4645	4656	4667	1	2	3	4	5	6	7	8	9	10	10
.67	4677	4688	4699	4710	4721	4732	4742	4753	4764	4775	1	2	3	4	5	6	7	8	9	10	10
.68	4786	4797	4808	4819	4831	4842	4853	4864	4875	4887	1	2	3	4	5	6	7	8	9	10	10
.69	4898	4909	4920	4932	4943	4955	4966	4977	4989	5000	1	2	3	5	6	7	8	9	10	10	10
.70	5012	5023	5035	5047	5058	5070	5082	5093	5105	5117	1	2	4	5	6	7	8	9	10	11	11
.71	5129	5140	5152	5164	5176	5188	5200	5212	5224	5236	1	2	4	5	6	7	8	10	11	11	11
.72	5248	5260	5272	5284	5297	5309	5321	5333	5346	5358	1	2	4	5	6	7	9	10	11	11	11
.73	5370	5383	5395	5408	5420	5433	5445	5458	5470	5483	1	3	4	5	6	8	9	10	11	11	11
.74	5495	5508	5521	5534	5546	5559	5572	5585	5598	5610	1	3	4	5	6	8	9	10	11	12	12
.75	5623	5636	5649	5662	5675	5689	5702	5715	5728	5741	1	3	4	5	7	8	9	10	11	12	12
.76	5754	5768	5781	5794	5808	5821	5834	5848	5861	5875	1	3	4	5	7	8	9	11	12	12	12
.77	5888	5902	5916	5929	5943	5957	5970	5984	5998	6012	1	3	4	5	7	8	10	11	12	12	12
.78	6026	6039	6053	6067	6081	6095	6109	6124	6138	6152	1	3	4	6	7	8	10	11	13	13	13
.79	6166	6180	6194	6209	6223	6237	6252	6266	6281	6295	1	3	4	6	7	9	10	11	13	13	13
.80	6310	6324	6339	6353	6368	6383	6397	6412	6427	6442	1	3	4	6	7	9	10	12	13	13	13
.81	6457	6471	6486	6501	6516	6531	6546	6561	6577	6592	2	3	5	6	8	9	11	12	14	14	14
.82	6607	6622	6637	6653	6668	6683	6699	6714	6730	6745	2	3	5	6	8	9	11	12	14	14	14
.83	6761	6776	6792	6808	6823	6839	6855	6871	6887	6902	2	3	5	6	8	9	11	13	14	14	14
.84	6918	6934	6950	6966	6982	6998	7015	7031	7047	7063	2	3	5	6	8	10	11	13	15	15	15
.85	7079	7096	7112	7129	7145	7161	7178	7194	7211	7228	2	3	5	7	8	10	12	13	15	15	15
.86	7244	7261	7278	7295	7311	7328	7345	7362	7379	7396	2	3	5	7	8	10	12	13	15	15	15
.87	7413	7430	7447	7464	7482	7499	7516	7534	7551	7568	2	3	5	7	9	10	12	14	16	16	16
.88	7586	7603	7621	7638	7656	7674	7691	7709	7727	7745	2	4	5	7	9	11	12	14	16	16	16
.89	7762	7780	7798	7816	7834	7852	7870	7889	7907	7925	2	4	5	7	9	11	13	14	16	16	16
.90	7943	7962	7980	7998	8017	8035	8054	8072	8091	8110	2	4	6	7	9	11	13	15	17	17	17
.91	8128	8147	8166	8185	8204	8222	8241	8260	8279	8299	2	4	6	8	9	11	13	15	17	17	17
.92	8318	8337	8356	8375	8395	8414	8433	8453	8472	8492	2	4	6	8	10	12	14	15	17	17	17
.93	8511	8531	8551	8570	8590	8610	8630	8650	8670	8690	2	4	6	8	10	12	14	16	18	18	18
.94	8710	8730	8750	8770	8790	8810	8831	8851	8872	8892	2	4	6	8	10	12	14	16	18	18	18
.95	8913	8933	8954	8974	8995	9016	9036	9057	9078	9099	2	4	6	8	10	12	15	17	19	19	19
.96	9120	9141	9162	9183	9204	9226	9247	9268	9290	9311	2	4	6	8	11	13	15	17	19	19	19
.97	9333	9354	9376	9397	9419	9441	9462	9484	9506	9528	2	4	7	9	11	13	15	17	20	20	20
.98	9550	9572	9594	9616	9638	9661	9683	9705	9727	9750	2	4	7	9	11	13	16	18	20	20	20
.99	9772	9795	9817	9840	9863	9886	9908	9931	9954	9977	2	5	7	9	11	14	16	18	20	20	20

INDEX OF AUTHORS

- ACREE, S. F., 53
 ARRHENIUS, Sv., 1
- BAWDEN, 126
 BETTIE, 113
 BILMANN, E., 101, 103
 BJERRUM, N., v, 4, 7
 BOLDYREFF, 122
 BRITTON, H. T. S., v, 86, 93, 112
 BRÖNSTED, J. N., 5
- CALLAN, T. S., 141
 CAMPBELL, M. A., 104
 CLARK, W. M., v, 4, 26, 35, 59, 70, 79,
 85, 93, 96, 98, 112
 COMPTON, 86
 COX, D. C., 126
 COWPERTHWAITTE, 126
- DEBYE, P., 3, 4
 DOLE, 126
 DOLEZALEK, 86
 DRAKE, N. L., 28
 DU BOIS-REYMOND, 82
 DUTOIT, 137
- ERVING, W. W., 93
- FAWCETT, 53
 FENWICK, F., 110, 126
 FOULK, C. W., 126
 FURMAN, N. H., vi, 86, 93, 108, 110,
 112, 133, 126
- GILLESPIE, L. J., 43
 GOODE, J., 91
 GYEMANT, A., 50
- HABER, F., 112
 HARDING, W. C., 28
- HORROBIN, S., 141
 HOSTETTER, 126
 HÜCKEL, E., 3, 4
 HULETT, G. A., 93
 HURWITZ, 51
- ISHIMARU, I., 111
- JANDER, G., 140, 151
 JONES, 126
- KAMEDA, T., 53, 99
 KAMIENSKI, 125
 KERRIDGE, J., 87
 KLEMENSIEWICZ, 112
 KOLTHOFF, I. M., vi, 4, 27, 36, 41, 46,
 49, 53, 86, 98, 99, 110, 122, 141
 KOPACZEWSKI, W., v
- LAMMERT, O. M., 104
 LAMER, V. K., 4
 LEWIS, G. N., 2, 3
 LIPSCOMB, G. T., 93
 LINDEMANN, 86
 LINDERSTRÖM-LANG, K., 98, 106
 LUBS, 28
 LUND, H., 49, 101
 LUTHER, 85
- MACINNES, D. A., 112, 113, 126
 MEYER, 51
 MICHAELIS, L., v, 47, 50
 MISLOWITZER, E., v
 MORGAN, J. L. R., 104
 MÜLLER, E., vi, 124, 127
- NERNST, W., 63

- OSTENBERG, 51
OSTWALD, W., 85
- PFUNDT, O., 140, 151
PINKHOF, J., 123
POGGENDORF, 82
PRIDEAUX, E. B. R., vi
- RANDALL, M., 2
ROBERTS, E. J., 110, 126
- SLYKE, D. D. VAN, 21
SÖRENSEN, S. P. L., v, 8, 35, 40, 98, 106
- THIEL, A., v
TREADWELL, W. D., 123, 141
- UNMACK, A., 7
- VANNAME, 126
VEIBEL, S., 95
VLEESCHHOUWER, J. J., 36
- WALBUM, L. E., 40
WALPOLE, 51
WILLARD, H. H., 122, 126
WILSON, 126

INDEX OF SUBJECTS

A

- Acetic acid, conductometric titration, 142
 - neutralization curve, 119
- Acid exponent, 9
- Acidity, 12
- Acids, 5
 - Brönsted definition, 5
 - dissociation, 8
 - Cf.* Neutralization reactions, and Titrations
- Activity, coefficient, 3, 4, 55, 65
 - ions, 2, 22, 55, 65
- Adsorption, by precipitates, 150
 - in color determination of pH , 60
- Air electrode, 107
- Aliphatic compounds, influence on hydrogen electrode, 101
- Alizarine yellow, 31
- Alkaloids, influence on hydrogen electrode, 101
- Alternating current galvanometer, 139
- Ammonium salts, conductometric titration, 148
- Antilogarithms, 158
- Antimony, antimonious oxide electrode, 110
 - antimonious oxide, preparation of, 110
- Aromatic compounds, influence on hydrogen electrode, 101
- Arsenious trioxide, influence on hydrogen electrode, 101

B

- Barium acetate, as reagent, 151
- Bases, *cf.* Acids
- Batteries, 84
- Bicolorimeter, 44

- Bi-metallic electrodes, 124
- Binant electrometer, 86
- Borax, for buffers, 37, 40
- Boric acid, conductometric titration, 144
 - for buffers, 37, 40
 - influence on quinhydrone electrode, 107
- Bromcresolgreen, color-change interval, 31
 - ionization constant, 46
 - salt correction, 58
 - solution, preparation of, 30
- Bromcresolpurple, ionization constant, 46
- Bromphenolblue, color-change interval, 31
 - dichromatism, 28
 - ionization constant, 46
 - salt correction, 58
 - solution, preparation of, 30
- Bromphenolred, 30, 31
- Bromthymolblue, 30, 31
 - ionization constant, 46
 - salt correction, 58
- Buffer capacity, 19
- Buffer solutions, influence of dilution, 41
 - influence of temperature, 40
 - of Clark and Lubs, 38, 39
 - of Kolthoff, 40
 - of Sörensen, 40
 - reaction, 17
 - selected sets, 35

C

- Calomel electrodes, 93
 - as reference electrode with hydrogen electrode, 97
 - as reference electrode with quinhydrone electrode, 103

Capillary electrometer, 86
 "Carborundum" electrode, 125
 Chloride, conductometric titration, 151
 precipitation with silver electrode, 128
 Chlorophenolred, 30, 31
 ionization constant, 46
 salt correction, 58
 Coating, of hydrogen electrode, 98
 Color-change interval indicators, 25
 Colorimeter, Gillespie, 44
 Walpole, 51
 Colorimetric determination of pH , *cf.*
 Hydrogen-ion concentration
 Comparator, 43, 51
 Compensation method (E.M.F.), 82
 Concentration cells, 73
 Conductometric titrations, 133
 acid-base titrations, 141
 limitations, 137
 performance, 137
 practical course, 154
 precipitation reactions, 148
 problems, 152
 theory, 133
 Crystal detector, 140

D

Detector, 140
 Dichromatism, bromphenolblue, 28
 Differential titrations, 126
 Diffusion potentials, 79
 Dinitrophenols, 48
 α -dinitrophenol, indicator constant,
 49
 β -dinitrophenol, indicator constant,
 49
 γ -dinitrophenol, indicator constant,
 49
 Dissociation, electrolytes, 2
 Dyestuffs, influence on hydrogen elec-
 trode, 101

E

Electrodes, 63
 bi-metallic, 124
 electrode potentials, 63
 indicator electrode, 124, 127

Electrodes, polarized, 126
 reference, 79
 Electrolytes, dissociation, 2
 Electrolytic dissociation, *cf.* Dissocia-
 tion
 Electrolytic solution tension, 64
 Electrometers, 86
 Electromotive force, of cell, 82
 Electron affinity, 70
 Electron tubes, 91
 Equivalence point, location in potenti-
 ometric titrations, 117, 121
 titration to, 123
 Equivalence potential, 114
 in neutralization reactions, 114, 117
 in oxidation-reduction reactions, 115,
 118
 in precipitation reactions, 115, 121

G

Galvanometers, 85
 for alternating current, 139
 Glass electrode, 112
 composition of electrode, 112

H

Half-cells, standard, 79
 Heptamethoxytriphenylcarbinol, 48
 indicator constant, 49
 Hexamethoxytriphenylcarbinol, 48
 indicator constant, 49
 Higher oxide electrodes, 71, 108
 Hydrochloric acid, for buffers, 36
 neutralization curve, 117
 Hydrogen electrode, calculation of pH ,
 97
 checking of, 100
 correction for pressure, 76
 interferences, 100
 normal, 76
 platinization of, 98
 shape of cell, 97
 theory of, 73
 Hydrogen exponent, *cf.* Hydrogen ions
 Hydrogen generators, 99
 Hydrogen ions, 5
 concentration in acids, 8

Hydrogen ions, concentration in buffers, 17
 concentration in salts, 12
 concentration in water, 7
 Hydrogen-ion activity, 55, 97
Cf. Hydrogen ions
 Hydrogen-ion determination (colorimetrically), 34
 colloid effect, 59
 colored solutions, 50
 comparators, 51
 medium effect, 60
 protein effect, 59
 salt effect, 53, 58
 unbuffered solutions, 52
 with buffers, 41
 without buffers, 43
 Hydrogen-ion determination (potentiometrically), 73
 with antimony electrode, 110
 with glass electrode, 112
 with higher oxide electrode, 109
 with hydrogen electrode, 97
 with metal-metallic oxide electrode, 109
 with mercury-mercuric oxide electrode, 110
 with oxygen and air electrode, 109
 with quinhydrone electrode, 101
 with silver-silver oxide electrode, 110
 Hydrogen sulphide, poison for hydrogen electrode, 100
 Hydrolysis, 12
 Hydrolysis constant, 13
 Hydronium ions, 5
 Hydroxyl ions, 5
 interference with quinhydrone electrode, 105

I

Indicator constants, 24
 Indicator electrodes, 127
 Indicator exponents, 26
 Indicators, color change, 24
 concentration and color, 32
 constants, 46, 49
 isohydric solutions, 53

Indicators, medium and color, 33
 one color, 47
 practical course, 153
 table of color-change interval, 31
 temperature and color, 33
 two color, 43
 Indicator solutions, adjusted solutions, 53
 preparation of, 27
 salt correction, 58
 Ionic strength, 3
 Ionization, *cf.* Dissociation and Ion activity
 Ionization constants, acids and bases, 11
 Ionization product of water, 7
 Ion mobility, 135
 Ions, concentration and activity, 2

L

Lead nitrate, as reagent, 151
 Lead peroxide, electrode, 109
 Liquid junction potential, 78
 Lithium oxalate, as reagent, 151
 Lithium sulphate, as reagent, 151
 Logarithms, 156

M

Manganese dioxide electrode, 109
 Megohm, 85
 Mercuric perchlorate, as reagent, 151
 Mercury-mercuric oxide electrode, 100
 Metal ions, influence on hydrogen electrode, 101
 Metal-metallic oxide electrode, 109
 Metals, normal potentials, 67
 potentials, 63
 Methoxytriphenylcarbinol, 48
 Methylorange, 30, 31
 deviation in Clark's buffers, 36
 ionization constant, 46
 salt correction, 58
 Methylred, 30, 31
 ionization constant, 46
 salt correction, 58
 Methylyellow, 31

N

- Neutralization reactions, 114, 117, 141
 - conductometrically, 141
 - potentiometrically, 117
- Nitrophenols, 48
 - m*-nitrophenol, indicator constant, 49
 - p*-nitrophenol, indicator constant, 49
 - titration, conductometrically, 144
- Normal potentials, 66
 - of metals, 66
 - of oxidizing-reducing systems, 74
- Null-point instruments, 85

O

- Oxidation-reduction, normal potentials, 74
 - potentials, 67
 - reactions, 115
 - titrations, 115, 120
- Oxides, *cf.* Higher oxides
- Oxidizing substances, influence on
 - hydrogen electrode, 101
 - influence on quinhydrone electrode, 101
 - influence on antimony electrode, 101
- Oxygen, electrode, 107
 - influence on hydrogen electrode, 100

P

- Pentamethoxytriphenylcarbinol, 48
 - indicator constant, 49
- Phenol, conductometric titration, 144
- Phenolphthalein, color-change interval, 31
 - color strength and pH , 50
 - salt correction, 58
 - structure change, 29
 - titration, conductometrically, 144
- Phenolred, 30, 31
 - ionization constant, 46
 - salt correction, 58
- Pinachrom, 48
 - indicator constant, 49
- Platinization of hydrogen electrode, 98
- Polarized electrodes, 126

- Potassium, chloride for buffers, 37
 - chloride salt bridge, 79
 - diphthalate for buffers, 36
 - mono-citrate for buffers, 37
 - mono-citrate, preparation of, 37
 - mono-phosphate for buffers, 36
- Potentials, 63
 - equivalence potential, 114
 - liquid junction, 78
 - measurement, 82
 - of metal electrodes, 63, 67
 - oxidation-reduction, 67
- Potentiometer, 87
- Potentiometric measurements, 82
- Potentiometric technique, 82
- Potentiometric titrations, location of
 - equivalence point, 120
 - performance, 127
 - theory of, 115
 - various methods, 123
- Potentiometry, practical course, 153

Q

- Quadrant electrometer, 86
- Quinaldinred, 48
 - indicator constant, 49
- Quinhydrone, preparation of, 103
- Quinhydrone electrode, as reference, 95, 97
 - influence of boric acid, 107
 - influence of oxidizing and reducing substances, 102
 - in potentiometric titrations, 104, 105
 - salt error, 106
 - sources of error, 105
 - temperature coefficient, 103
 - various cells, 104

R

- Reaction, 7
 - of acid and salt mixtures, 17
 - of salts, 12
 - of water, 7
- Reducing substances, influence on
 - hydrogen electrode, 101
 - influence on quinhydrone electrode, 106

Reference electrodes, 79, 93
Replacement titrations, 147

S

Salicylic acid, conductometrically, 143
Salt bridge, 79, 93
Salt corrections, 57, 58
Salt effect, on colorimetric determinations, 53
 on indicator constant, 46, 49
 on quinhydrone electrode, 106
Silicon carbide electrode, 125
Silver, precipitation with chloride, 120
 titration, conductometrically, 151
Silver nitrate, as reagent, 151
Silver-silver chloride electrode, 113
Silver-silver oxide electrode, 110
Sodium chromate, as reagent, 151
Sodium perchlorate, as reagent, 151
Solution tension, 64
Spectrophotometer, 45
Standard acid mixture, 95
Standard cells, 84
Standard half-cells, 79
Standard solutions, for checking hydrogen electrode, 100
Storage battery, 84
Sulfate, conductometric titration, 151
Sulfonphthaleins, structure change, 29
 titration, conductometrically, 147

T

Temperature, influence on ionization water, 7
Tetrabromophenolblue, 30
 color-change interval, 31

Tetrabromophenolblue, solution, preparation of, 30
Text books, v, vi
Thermionic valve method, 91
Thermocross, 140
Thymolblue, color-change interval, 31
 ionization constant, 46
 salt correction, 58
 solution, preparation of, 30
Thymolphthalein, salt correction, 58
Titration cells, conductometric, 137
Titration curves, 117
Titrations (conductometrically), 133
 complex reactions, 148
 neutralization reactions, 141
 precipitation reactions, 148
Titrations (potentiometrically), 114
 differential, 126
 neutralization reactions, 114, 117
 oxidation-reduction reactions, 115, 120
 precipitation reactions, 115, 118
 to equivalence potential, 123
Transformer, 140.
Transition interval indicator, 25
Tropeoline OO, 31

V

Vanillin, conductometric titration, 145
Voltmeter, 90

W

Water, dissociation, 6
 ionization product, 7
Wedge colorimeter, 44
Weston cell, 85
Wheatstone bridge, 139

