

TIGHT BINDING BOOK

UNIVERSAL
LIBRARY

OU 160780

UNIVERSAL
LIBRARY

Dynamics of Rotation.

PREFACE TO THE FIRST EDITION

MANY students of Physics or Engineering, who from want either of mathematical aptitude, or of sufficient training in the methods of analytical solid geometry, are unable to follow the works of mathematical writers on Rigid Dynamics, must have felt disappointed, after mastering so much of the Dynamics of a Particle as is given in the excellent and widely-used text-books of Loney, or Garnett, or Lock, to find that they have been obliged, after all, to stop short of the point at which their knowledge could be of appreciable practical use to them, and that the explanation of any of the phenomena exhibited by rotating or oscillating rigid bodies, so interesting and obviously important, was still beyond their reach.

The aim of this little book is to help such students to make the most of what they have already learnt, and to carry their instruction to the point of practical utility.

As a matter of fact, any one who is interested and observant in mechanical matters, and who has mastered the relations between force, mass, and acceleration of velocity of translation, will find no difficulty in apprehending the corresponding relations between couples, moments of inertia, and angular accelerations, in a rigid

body rotating about a fixed axle, or in understanding the principle of the Conservation of Angular Momentum.

Instead of following the usual course of first developing the laws of the subject as mathematical consequences of D'Alembert's Principle, or the extended interpretation of Newton's Second and Third Laws of Motion, and then appealing to the experimental phenomena for verification, I have adopted the opposite plan, and have endeavoured, by reference to the simplest experiments that I could think of, to secure that the student shall at each point gain his *first* ideas of the dynamical relations from the phenomena themselves, rather than from mathematical expressions, being myself convinced, not only that this is the best way of bringing the subject vividly and without vagueness before the learner, but that such a course may be strongly defended on other grounds.

These considerations have determined the arrangement of the chapters and the limitations of the work, which makes no pretence at being a complete or advanced treatise.

My best thanks are due to those friends and pupils who have assisted me in the revision of the proof-sheets and in the working of examples, but especially to my colleague, Mr. W. Larden, for very many valuable suggestions and corrections.

A. M. W.

DEVONPORT, 31st Oct. 1891.

PREFACE TO THE SIXTH EDITION

THE demand for successive editions of this book has afforded opportunities for considerable improvements since its first issue. Errors and omissions kindly pointed out by readers and friendly critics have been rectified, while the continued use of the book as a text-book with my own students has enabled me to detect and alter ambiguous phrases, and in some places to improve the arrangement of the argument.

The use of the Inertia-Skeleton, introduced on p. 64, has proved so satisfactory a simplification for non-mathematical students, to whom a momental ellipsoid would be only a stumbling-block, and could be used so readily for further extensions, in the manner indicated on pp. 122 and 123, that I hope I may be pardoned for calling attention to it.

Experiments with a gyroscope, made by the students themselves with Chapter XIII. as guide, have proved very satisfactory and interesting, and may usefully include a deduction of the rate of spin from an observation of the rate of precession, after the moment of inertia of the wheel has been determined by means of the oscillating table figured on p. 80.

In the interests of clear teaching, the convention (which I am glad to see has been adopted in America) has been adhered to throughout, of using the word 'pound' when a force is meant, and 'lb.' when a mass is meant, and I have ventured to give the name of a 'slug' to the British Engineer's Unit of Mass, *i.e.* to the mass in which an acceleration of one foot-per-sec.-per-sec. is produced by a force of one pound.

A. M. W.

DEVONPORT, 11th June 1906.

CONTENTS.

CHAPTER I.

DEFINITIONS OF TERMS AND PRELIMINARY KINEMATICS.

Page 1.	Rigid Body.
„	2. Angular Velocity.
„	2. Rate of Revolution.
„	3. Relation between (v) and (ω).
„	3. Angular Acceleration.
„	3. Uniformly Accelerated Rotation.
„	5. Examples.
„	6. Geometrical Representation of Angular Velocities and Accelerations.
„	7. On the Use of the word Moment.
„	8. Definition of Torque.
„	8. Definition of Equal Torques.
„	8. Fundamental Statical Experiment.
„	8. Measure of Torque.
„	8. Unit Torque.
„	9. British Absolute Unit of Torque.
„	9. Gravitation or Engineer's British Unit of Torque.
„	9. Distinction between 'pound' and 'lb.'

CHAPTER II.

ROTATION UNDER THE INFLUENCE OF TORQUE.

Page 11.	Proposition I.
„	12. Proposition II.
„	13. Methods of Experimental Verification.

-
- Page 14. Variation of the Experiments.
- „ 15. Familiar Instances.
 - „ 15. The Analogue of Mass in Rotational Motion.
 - „ 17. Rotational Inertia.
 - „ 17. Definition of the Unit of Rotational Inertia.
 - „ 18. Examples for Solution.
 - „ 18. To Calculate the Rotational Inertia of any Rigid Body.
 - „ 18. Proposition III.
 - „ 19. Rotational Inertia of an Ideal Single-particle System.
 - „ 20. Moment of Inertia.
 - „ 20. Unit Moment of Inertia.
 - „ 21. Definition of Angular Momentum.
 - „ 22. To find the Kinetic Energy of a Rigid Body rotating about a Fixed Axle.
 - „ 23. Work done by a Couple.
 - „ 23. Analogy with the Expression for the Work done by a force in Rectilinear Motion.
 - „ 24. Change of Kinetic Energy due to a Couple.
 - „ 24. Radius of Gyration.
 - „ 25. Numerical Examples.
 - „ 30. Note to Chapter II. D'Alembert's Principle.

CHAPTER III

DEFINITIONS, AXIOMS, AND ELEMENTARY THEOREMS NECESSARY FOR DEALING WITH MOMENTS OF INERTIA—ROUTH'S RULE AND ITS APPLICATION.

- Page 33. Definition of Moment of Inertia of an Area.
- „ 33. Definition of Moment of Inertia of a Volume.
 - „ 34. Axiom.
 - „ 34. Illustration.
 - „ 34. Axiom.
 - „ 35. Proposition I.

-
- Page 36. Routh's Rule for Finding the Moment of Inertia about an Axis of Symmetry in certain cases.
- , 36. Examples of the Application of Dr. Routh's Rule.
 - ,, 37. Theorem of Parallel Axes.
 - ,, 38. Proposition II.
 - ,, 39. Applications.
 - ,, 40. Proposition III.
 - ,, 42. Examples for Solution on Chapters I., II., and III.

CHAPTER IV.

MATHEMATICAL PROOFS OF THE DIFFERENT CASES INCLUDED
UNDER ROUTH'S RULE.

- Page 46. To Find I for a Uniform Thin Rod about a Perpendicular Axis through one end.
- ,, 47. Corollary.
 - ,, 48. Rectangle.
 - ,, 48. Circular Disc.
 - ,, 50. Thin Rod by Integration.
 - ,, 50. Circular Disc by Integration.
 - ,, 51. Moment of Inertia of an Ellipse.
 - ,, 52. Sphere and Cone.
 - ,, 52. Sphere by Integration.
 - ,, 53. Exercises.

CHAPTER V.

FURTHER PROPOSITIONS CONCERNING MOMENTS OF INERTIA—PRINCIPAL
AXES—GRAPHICAL REPRESENTATION OF INERTIA—CURVES AND SUR-
FACES—EQUIMOMENTAL SYSTEMS—INERTIA SKELETONS.

- Page 55. Proposition IV.
- ,, 56. Propositions V. and VI.
 - ,, 58. Proposition VII.

- Page 60. Graphical Construction of Inertia-Curves and Surfaces.
 ,, 62. Diagrams of Inertia Curves.
 ,, 63. Construction of Moment of Inertia Surface.
 ,, 64. Equipomental Systems—Proposition VIII
 ,, 64. Inertia Skeleton—Proposition IX.

CHAPTER VI.

SIMPLE HARMONIC MOTION

- Page 67. Definition of Simple Harmonic Motion.
 ,, 68. Definition of Period.
 ,, 69. Definition of Phase.
 ,, 69. Expression for the Period or Time of a Complete Oscillation.

CHAPTER VII.

AN ELEMENTARY ACCOUNT OF THE CIRCUMSTANCES AND LAWS OF
ELASTIC OSCILLATIONS.

- Page 70. Perfect or Simple Elasticity.
 ,, 70. Hooke's Law.
 ,, 71. Illustrations of Hooke's Law.
 ,, 72. Oscillations due to Elasticity.
 ,, 73. Ratio of Acceleration to Displacement.
 ,, 73. Expression for the Time of a Complete Oscillation.
 ,, 74. Applications.
 ,, 75. Extension to Angular Oscillations.
 ,, 76. Applications.
 ,, 76. Equivalent Simple Pendulum.
 ,, 77. Examples.
 ,, 79. Oscillating Table for Finding Moments of Inertia.
 ,, 81. Examples for Solution.

CHAPTER VIII.

CONSERVATION OF ANGULAR MOMENTUM.

- Page 82. Analogue in Rotation to Newton's Third Law of Motion.
 „ 83. Application of the Principle in cases of Motion round a fixed Axle.
 „ 83. First Example.
 „ 84. Second Example.
 „ 85. Third Example.
 „ 85. Fourth Example.
 „ 87. Consideration of the Kinetic Energy.
 „ 87. Other Exemplifications of the Principle of the Conservation of Angular Momentum.
 „ 88. Graphical representation of Angular Momentum.
 „ 89. Moment of Momentum. ✓
 „ 89. Conservation of Moment of Momentum.
 „ 91. General Conclusion.
 „ 91. Caution.
 „ 91. Ballistic Pendulum.
 „ 93. Examples.

CHAPTER IX.

ON THE KINEMATICAL AND DYNAMICAL PROPERTIES OF THE CENTRE OF MASS.

- Page 94. Evidence of the Existence for a Rigid body of a point possessing peculiar Dynamical Relations.
 „ 95. Experiments (1), (2), and (3).
 „ 96. Experiments (4) and (5).
 „ 96. A Couple causes Rotation about an Axis through the Centre of Gravity.
 „ 97. Experiment (6) with a Floating Magnet.
 „ 98. Experiment (7).

Page	99.	Definition of Centre of Mass.
„	100.	Proposition I.—(Kinematical.) On the Displacement of the Centre of Mass.
„	101.	Pure Rotation and Translation.
„	101.	Proposition II.—(Kinematical.) On the Velocity of the Centre of Mass.
„	101.	Proposition III.—(Kinematical.) On the Acceleration of the Centre of Mass.
„	102.	Summary.
„	102.	Corresponding Propositions about Moments.
„	103.	Proposition IV. On the Resultant Angular Momentum
„	104.	Proposition V. Resultant Moment of the Mass-accelerations.
„	104.	Proposition VI. On the Motion of the Centre of Mass of a body under External Forces.
„	105.	Proposition VII. On the Application of a Couple to a Free Rigid Body at Rest.
„	105.	Proposition VIII. The Motion of the Centre of Mass does not affect Rotation about it.
„	106.	Independent treatment of Rotation and Translation.
„	106.	On the Direction of the Axis through the Centre of Mass about which a Couple causes a free Rigid Body to turn. <i>Caution.</i>
„	107.	Total Kinetic Energy of a Rigid Body.
„	108.	Examples.
„	110.	Examples for Solution.

CHAPTER X.

CENTRIPETAL AND CENTRIFUGAL FORCES.

Page	111.	Consideration of the Forces on the Axle.
„	111.	Proposition. Uniform Motion of a Particle in a Circle.
„	112.	Use of the terms 'Centripetal Force' and 'Centrifugal Force.'
„	113.	Centripetal Forces in a Rotating Rigid Body.
„	113.	Rigid Lamina.
„	115.	Extension to Solids of a certain type.
„	116.	Convenient Dynamical Artifice.

-
- Page 117. Centrifugal Couples.
,, 118. Centrifugal Couple in a body of any shape.
,, 119. Centrifugal Couples vanish when the Rotation is about a Principal Axis.
,, 121. Importance of Properly Shaping the Parts of Machinery intended to Rotate rapidly.
,, 121. Equipomental Bodies similarly rotating have equal and similar Centrifugal Couples.
,, 121. Substitution of the 3-rod Inertia-Skeleton.
,, 123. Transfer of Energy under the action of Centrifugal Couples

CHAPTER XI.

CENTRE OF PERCUSSION.

- Page 125. Thin Uniform Rod.
,, 126. Experiment.
,, 127. Experiment.
,, 128. Illustrations—Cricket Bat, Door.
,, 128. Centre of Percussion in a Body of any Form.

CHAPTER XII.

ESTIMATION OF THE TOTAL ANGULAR MOMENTUM.

- Page 130. Simple Illustrations.
,, 132. Additional Property of Principal Axes.
,, 133. Total Angular Momentum.
,, 133. The Centripetal Couple.
,, 135. Rotation under the influence of no Torque. The Invariable Axis.

CHAPTER XIII.

ON SOME OF THE PHENOMENA PRESENTED BY SPINNING BODIES.

- Page 136. Gyroscope.
,, 137. Experiments (1), (2), and (3).

-
- Page 138. Experiment (4).
 „ 139. Definition of Precession.
 „ 139. Experiment (5).
 „ 140. Experiments (6), (7), and (8).
 „ 141. Experiments (9) and (10).
 „ 141. Precession in Hoops, Tops, etc.
 „ 142. Further Experiment with a Hoop.
 „ 143. Bicycle.
 „ 143. Explanation of Precession.
 „ 145. Analogy between Steady Precession and Uniform Motion in a Circle.
 „ 145. Calculation of the Rate of Precession.
 „ 148. Observation of the 'Wobble.'
 „ 150. Explanation of the *Starting* of Precession.
 „ 152. Gyroscope with Axle of Spin Inclined.
 „ 153. Influence of the Centrifugal Couple.
 „ 154. Explanation of the effects of impeding or hurrying Precession.
 „ 154. The Rising of a Spinning Top.
 „ 156. Calculation of the 'Effort to Precess.'
 „ 157. Example (1) Precessional Forces due to the wheels of a railway-engine rounding a curve.
 „ 157. Precessional Stresses on the machinery of a pitching, rolling, or turning ship.
 „ 158. Example (2) Torpedo-boat turning.
 „ 159. Miscellaneous Examples.
 „ 160. Appendix (1) On the terms Angular Velocity and Rotational Velocity.
 „ 161. Appendix (2) On the Composition of Rotational Velocities.
 „ 161. Appendix (3) The Parallelogram of Rotational Velocities.
 „ 164. Appendix (4) Evaluation of the steady precessional velocity of a gyroscope or top with the axis of spin inclined.
 „ 166. Appendix (5) Note on Example (4) p. 86.
 „ 166. Appendix (6) On the connection between the Centripetal Couple and the residual Angular Momentum,

DYNAMICS OF ROTATION.

CHAPTER I.

DEFINITIONS OF TERMS AND PRELIMINARY KINEMATICS.

Rigid Body.—A body in Dynamics is said to be rigid (*i.e.* stiff) so long as the forces acting upon it do not change the relative positions of its parts.

We shall deal, at first, chiefly with such familiar rigid bodies as a fly-wheel turning on its axle; a cylindrical shaft; a grindstone; a door turning on its hinges; a pendulum; a magnetic compass-needle; the needle of a galvanometer with its attached mirror.

It should be observed that such a body as, for example, a wheelbarrow being wheeled along a road is not, taken as a whole, a rigid body, for any point on the circumference of the wheel changes its position with respect to the rest of the barrow. The wheelbarrow consists, in fact, of two practically rigid bodies, the wheel and the barrow.

On the other hand, a sailing-boat may be regarded as a rigid body so long as its sails are taut under the influence of the wind, even though they be made of a material that is far from rigid when otherwise handled.

So also a stone whirled by an inextensible string constitutes, with the string, a single body which may be regarded as rigid so long as the string is straight.

Angular Velocity.—When a rigid body turns about a fixed axis, every particle of the body describes a circle about this axis in the same time. If we conceive a radius to be drawn from the centre of any such circular path to the particle describing it, then, if the rotation be uniform, the number of unit angles swept out in unit time by such a radius is the measure of what is called the angular velocity of the body, or its rotational velocity.

The unit of time invariably chosen is the second, and the unit angle is the ‘radian,’ *i.e.* the angle of which the arc is equal to the radius.

Hence, in brief, we may write

Angular velocity (when uniform) = Number of radians described per second.

The usual symbol for the rotational or angular velocity of a body is ω (the Greek omega).

When the rotational velocity is not uniform, but varies, then its value at any instant is the number of radians that would be swept out per second if the rate of turning at that instant remained uniform for a second.*

Rate of Revolution.—Since in one revolution the radius describes 2π radians, it follows that the number of revolutions made per second when the angular velocity is ω , is $\frac{\omega}{2\pi}$, and that when a body makes one revolution per second, it describes 2π unit angles per sec., and has therefore an angular velocity $= \omega = 2\pi$.

Thus a body which makes 20 turns a minute has an angular velocity $\frac{20 \times 2\pi}{60} = \frac{2\pi}{3}$.

Tangential Speed.—The linear velocity (v) of a particle

* See Appendix (I).

describing a circle of radius r about a fixed axis is at any instant in the direction of the tangent to the circular path, and is conveniently referred to as the tangential speed.

Relation between v and ω .—Since a rotational velocity ω radians per sec. corresponds to a travel of the particle over an arc of length $r\omega$ each second, it follows that

$$v = r\omega$$

$$\text{or } \omega = \frac{v}{r}$$

Very frequent use will be made of this relation.

Examples.—(1) A rotating drum 4 feet in diameter is driven by a strap which travels 600 feet a minute and without slipping on the drum. To find the angular velocity—

$$\omega = \frac{v}{r} = \frac{600}{\frac{4}{2}} = 5 \text{ radians per sec.}$$

(2) A wheel 3 feet in diameter has an angular velocity of 10. Find the speed of a point on its circumference.

$$v = r\omega$$

$$= 1.5 \times 10 \text{ feet per sec.}$$

$$= 15 \text{ feet per sec.}$$

Angular Acceleration.—When the rate of rotation of a rigid body about a fixed axle varies, then the rate of change of the angular or rotational velocity is called the angular or rotational acceleration, just as rate of change of linear velocity is called linear acceleration.

The usual symbol for angular acceleration is $\dot{\omega}$. Thus $\dot{\omega}$ is at any instant the number of radians per second that are being added per second at the instant under consideration. We shall deal at first with uniform angular accelerations, for which we shall use the less general symbol A .

Uniformly accelerated Rotation.—If a rigid body

start rotating from rest with a uniform angular acceleration A , then after t seconds the angular velocity ω is given by

$$\omega = At.$$

If the body, instead of being at rest, had initially an angular velocity ω_0 , then at the end of the interval of t seconds the angular velocity would be

$$\omega = \omega_0 + At \quad . \quad . \quad . \quad . \quad (i)$$

Since during the t seconds the velocity has grown at a uniform rate, it follows¹ that its average value during the interval, which, when multiplied by the time, will give the whole angle described, lies midway between, or is the arithmetic mean between, the initial and final values, *i.e.* the average angular velocity for the interval,

$$\begin{aligned} &= \frac{\omega_0 + (\omega_0 + At)}{2} \\ &= \omega_0 + \frac{1}{2}At; \end{aligned}$$

and the angle described

$$\begin{aligned} &= (\omega_0 + \frac{1}{2}At)t \\ &= \omega_0 t + \frac{1}{2}At^2 \quad . \quad . \quad . \quad . \quad (ii) \end{aligned}$$

By substituting in (ii) the value of t given in (i) we obtain the equation

$$\omega^2 = \omega_0^2 + 2A\theta \quad . \quad . \quad . \quad . \quad (iii),$$

which connects the angular velocity ω with initial velocity ω_0 and the angle θ swept through.

The student will observe that these equations are precisely similar to and are derived in precisely the same way as the three fundamental kinematic equations that he has learned to

¹ It is not considered necessary to reproduce here the geometrical or other reasoning by which this is established. See Garnett's *Elementary Dynamics*, and Lock's *Dynamics for Beginners*.

Example 3.—A wheel rotating 3000 times a minute has a uniform angular retardation of π radians per sec. each second. Find when it will be brought to rest, and when it will be rotating at the same rate in the opposite direction.

$$\begin{aligned} 3000 \text{ revolutions per min.} &= \frac{3000 \times 2\pi}{60} \\ &= 100\pi \text{ radians per sec.,} \end{aligned}$$

and will therefore be destroyed by the opposing acceleration π in 100 sec. The wheel will then be at rest, and in 100 sec. more the same angular velocity will have been generated in the opposite direction.

(Compare this example with that of a stone thrown vertically up and then returning.)

Geometrical Representation of Rotational Velocities and Accelerations.—At any particular instant the motion of a rigid body, with one point fixed, must be one of rotation with some definite angular velocity about some axis fixed in space and passing through the point. Thus the rotational velocity is, at any instant, completely represented by drawing a straight line, of length proportional to the rotational velocity, in the direction of the axis in question,

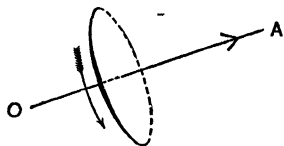

FIG. 1.

and it is usual to agree that the direction of drawing and naming shall be that in which a person looking along the axis would find the rotation about it to be right-handed (or clockwise). Thus the line OA would correspond to the

direction of rotation indicated in the fig.

If we choose to conceive a body as affected by simultaneous component rotations about three rectangular intersecting axes, we shall obtain the actual axis and rotational velocity, from the lines representing these components by the parallelogram law.

(For illustration and proof see Appendix (2) and (3).)

In the same way rotational acceleration about any axis fixed in space may be represented by drawing a line in its direction (with the same convention), and simultaneous rotational accelerations may be combined according to the parallelogram law.

On the Use of the word Moment.—The word *moment* was first used in Mechanics in its now rather old-fashioned sense of ‘importance’ or ‘consequence,’ and the moment of a force about an axis meant the importance of the force with respect to its power to generate in matter rotation about the axis; and again, the moment of inertia of a body with respect to an axis is a phrase invented to express the importance of the inertia of the body when we endeavour to turn it about the axis. When we say that the moment of a force about an axis varies as the force, and as the distance of its line of action from the axis, we are not so much defining the phrase ‘moment of a force,’ as expressing the result of experiments made with a view to ascertaining the circumstances under which forces are equivalent to each other as regards their turning power. It is important that the student should bear in mind this original meaning of the word, so that such phrases as ‘moment of a force’ and ‘moment of inertia’ may at once call up an idea instead of merely a quantity.

But the word ‘moment’ has also come to be used by analogy in a purely technical sense, in such expressions as the ‘moment of a mass about an axis,’ or ‘the moment of an area with respect to a plane,’ which require definition in each case. In these instances there is not always any corresponding physical idea, and such phrases stand, both historically and scientifically, on a different footing.

Unfortunately the words 'moment of a force' are regarded by some writers as the name rather of the product 'force \times distance from axis' than of the property of which this product is found by experiment to be a suitable measure. But happily for the learner the difficulty thus created has been met by the invention of the modern word *torque* to express 'turning power.'

Definition of Torque.—A force or system of forces which has the property of turning a body about any axis is said to be or to have a torque about that axis (from the Latin *torqueo*, I twist).

Definition of Equal Torques.—Two torques are said to be equal when each may be statically balanced by the same torque.

Fundamental Statical Experiment.—Torques are found to be equal when the products of the force and the distance of its line of action from the axis are equal. Experiments in proof of this may be made with extreme accuracy. The result may also be deduced from Newton's Laws of Motion.

Measure of Torque.—The value of a torque is the value of this product. This again is a matter of definition.

Unit Torque.—Thus the unit force acting at unit distance is said to be or to have unit torque, and a couple has unit torque about any point in its plane when the product of its arm and one of the equal forces is unity.

British Absolute Unit of Torque.—Since in the British absolute system, in which the lb. is chosen as the unit of mass, the foot as unit of length, and the second as unit of time, the unit of force is the poundal, it is reasonable and is agreed that the British absolute unit of torque shall be that of a poundal acting at a distance of 1 foot, or (what is the same thing, as regards turning) a couple of which the force is one poundal and the arm one foot. This we shall call a poundal-foot, thereby distinguishing it from the foot-poundal, which is the British absolute unit of work.

Gravitation or Engineer's British Unit of Torque.—In the Gravitation or Engineer's system in this country, which starts with the foot and second as units of length and time, and the pound pull (*i.e.* the earth's pull on the standard lb.) as unit of force, the unit of torque is that of a couple of which each force is 1 pound and the arm 1 foot. This may be called the 'pound-foot.'*

Distinction between 'pound' and 'lb.'—The student should always bear in mind that the word pound is used in two senses, sometimes as a force, sometimes as a mass. He will find that it will contribute greatly to clearness to follow the practice adopted in this book, and to write the word 'pound' whenever a force is meant, and to use the symbol 'lb.' when a mass is meant.

Axis and Axle.—An axis whose position is fixed relatively to the particles of a body may be conveniently referred to as an *axle*.

* On this system the unit mass is that to which a force of 1 pound would give an acceleration of 1 foot-per-second per second and is a mass of about 32.2 lbs. It is convenient to give a name to this practical unit of inertia, or sluggishness. We shall call it a 'slug.'

CHAPTER II.

ROTATION UNDER THE INFLUENCE OF TORQUE.

THE student will have learnt in that part of Dynamics which deals with the rectilinear motion of matter under the influence of force, and with which he is assumed to be familiar, that the fundamental laws of the subject are expressed in the three statements known as Newton's Laws of Motion. These propositions are the expression of experimental facts. Thus, nothing but observation or experience could tell us that the acceleration which a certain force produces in a given mass would be independent of the velocity with which the mass was already moving, or that it was not more difficult to set matter in motion in one direction in space than in another.

We shall now point out that in the study of the rotational motion of a rigid body we have exactly analogous laws and properties to deal with: only that instead of dealing with forces we have torques; instead of rectilinear velocities and accelerations we have angular velocities and accelerations; and instead of the simple inertia of the body we have to consider the importance or moment of that inertia about the axis, which importance or moment we shall learn how to measure.

It will contribute to clearness to enunciate these corresponding laws with reference first to a rigid body pivoted

about a fixed axle, *i.e.* an axis which remains fixed in the body, and in its position in space; and although it is possible to deduce each of the propositions that will be enunciated as consequences of Newton's Laws of Motion, without any further appeal to experiment, yet we shall reserve such deduction till later, and present the facts as capable, in this limited case at any rate, of fairly exact, direct experimental verification.

PROPOSITION I.—*The rate of rotation of a rigid body revolving about an axis fixed in the body and in space cannot be changed except by the application of an external force having a moment about the axis, i.e. by an external torque.*

Thus, a wheel capable of rotating about a fixed axle cannot begin rotating of itself, but if once set rotating would continue to rotate for ever with the same angular velocity, unless acted on by some external torque (due, *e.g.* to friction) having a moment about the axis. Any force whose line of action passes through the axis will, since this is fixed, be balanced by the equal and opposite pressure which fixes the axis. It is true that pressure of a rotating wheel against the material axle or shaft about which it revolves does tend to diminish the rate of rotation, but only indirectly by evoking friction which *has* a moment about the axis.

It is impossible in practice to avoid loss of rotation through the action of friction both with the bearings on which the body is pivoted and with the air; but since the rotation is always the more prolonged and uniform the more this friction is diminished, it is impossible to avoid the inference that the motion would continue unaltered for an indefinite period could the friction be entirely removed.

The student will perceive the analogy between this first

Proposition and that known as Newton's First Law of Motion.

PROPOSITION II.—*The angular acceleration or rate of change of angular velocity produced in any given rigid mass rotating about an axis fixed in the body and in space is proportional to the moment about the axis of the external forces applied, i.e. to the value of the external torque.*

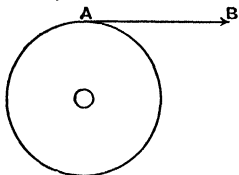

FIG. 2.

To fix the ideas, let the student think first of a wheel rotating about a fixed shaft passing through its centre, and to this wheel let us apply a constant torque by pulling with constant force the cord AB wrapped round the circumference.

[It may be well to point out here that if the wheel be accurately symmetrical, so that its centre of gravity lies in the axis of the shaft, then, as will be shown in the chapter on

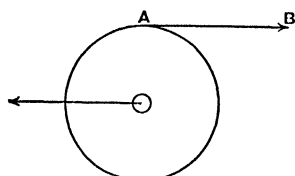

FIG. 3.

the Centre of Mass, since the centre of gravity or centre of mass of the wheel does not move, there must be some other equal and opposite external force acting on the body. This other force is the pressure of the axle, so that we are really applying a couple as in Fig. 2 ; but this latter force has no moment about the axis, and does not directly affect the rotation.]

Our Proposition asserts that

Our Proposition asserts that

- (1) So long as the torque has the same value, *i.e.* so long as the cord is pulled with the same force, the

acceleration of the angular velocity of the wheel is uniform, so that the effect on the wheel of any torque, in adding or subtracting angular velocity, is independent of the rate at which the wheel may happen to be rotating when the torque is applied.

- (2) That a torque of double or treble the value would produce double or treble the acceleration, and so on.
- (3) If several torques be applied simultaneously, the effect of each on the rotation is precisely the same as if it acted alone.

Also it follows

- (4) That different torques may be compared, not only statically but also dynamically, by allowing them to act in turn on the same pivoted rigid body in a plane perpendicular to the axis, and observing the angular velocity that each generates or destroys in the same time.

Methods of Experimental Verification.—Let an arrangement equivalent to that of the figure be made. AB is an accurately centred wheel turning with as little friction as possible on a horizontal axis, *e.g.* a bicycle wheel on ball bearings.

Round its circumference is wrapped a fine cord, from one end of which hangs a mass C of known weight (W), which descends in front of a graduated scale.

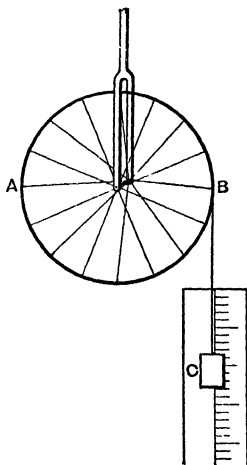

FIG. 4.

It will be observed that C descends with uniform acceleration. This proves that the tension (T) of the cord BC on the weight is uniform, and from observation of the value (*a*) of the acceleration, that of the tension is easily found, being given by the relation

$$\frac{W-T}{W} = \frac{a}{g}$$

(where *g* is the acceleration that would be produced in the mass by the force *W* alone), and T multiplied by the radius of the wheel is the measure of the torque exerted. Thus the arrangement enables us to apply a known and constant torque.

But since the linear acceleration of C is uniform, it follows that the angular acceleration of the wheel is uniform.

By varying the weight *W*, the torque may be varied, and other torques may be applied simultaneously by means of weights hung over the axle, or over a drum attached thereto, and thus the proportionality of angular acceleration to total resultant torque tested under various conditions.

It will be observed that in the experiments described we assume the truth of Newton's Second Law of Motion in order to determine the value of the tension (T) of the cord; but it is possible to determine this directly by inserting between C and B a light spring, whose elongation during the descent tells us the tension applied without any such assumption.

Variation of the Experiments.—Instead of using our known torque to generate angular velocity from rest, we may employ it to destroy angular velocity already existing in the following manner:—

Let a massive fly-wheel or disc be set rotating about an axis with a given angular velocity, and be brought to rest by

a friction brake which may be easily controlled so as to maintain a constant measurable retarding torque. It will be found that, however fast or slowly the wheel be rotating, the same amount of angular velocity is destroyed in the same time by the same retarding torque; that a torque r times as great destroys the same amount of angular velocity in $\frac{1}{r}$ of the time; while if a second brake be applied simultaneously the effect of its retarding couple is simply superadded to that of the first.

It may be remarked that the direct experimental verifications here quoted can be performed with probably greater accuracy than any equally direct experiment on *that part of Newton's Second Law of Motion to which our 2nd Proposition corresponds*, viz. that 'the linear acceleration of a given body is proportional to the impressed force, and takes place in the direction of the force.'

Thus, our second Proposition for rotational motion is really less far removed than is Newton's Second Law of Motion from fundamental experiment.

Familiar Instances.—Most people are quite familiar with immediate consequences of these principles. For example, in order to close a door every one takes care to apply pressure near the outer and not near the hinged side, so as to secure a greater moment for the force. A workman checking the rotation of any small wheel by friction of the hand applies his hand near the circumference, not near the axis.

The Analogue of Mass in Rotational Motion.—In the study of rectilinear motion it is found that if after making experiments on some given body we pass to another, the

same forces applied to the second body do not, in general, produce in it the same accelerations. The second body is found to be less easy or more easy to accelerate than the first. We express this fact by saying that the 'inertia' or 'mass' of the second body is greater or less than that of the first. Exactly the same thing occurs in the case of rotational motion, for experiment shows that the same torque applied to different rigid bodies for the same time produces, in general, different changes of angular velocity. Thus, the pull of a cord wrapped round the axle of a massive fly-wheel will, in say 10 seconds, produce only a very slow rotation, while the same torque applied to a smaller and lighter wheel will, in the same time, communicate a much greater angular velocity.

It is found, however, that the time required for a given torque to produce a given angular velocity does not depend simply on the mass of the rigid body. For, if the wheel be

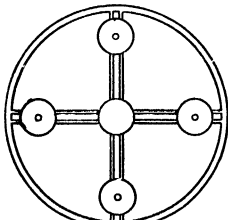

FIG. 5.

provided as in the figure with heavy bosses, and these be moved further from the axis, then, although the mass or inertia of the wheel, as regards bodily motion of the whole in a straight line, is unaltered, yet it is now found to be more difficult to accelerate rotationally than before.

The experiment may be easily made with our bicycle wheel of Fig. 4, by removing alternate tensional spokes and fitting it with others to which sliding masses can be conveniently attached.

With two wheels, however, or other rigid bodies, precisely similar in all respects except that one is made of a lighter

material than the other, so that the masses are different, it is found that the one of less mass is proportionately more easy to accelerate rotationally.

Hence we perceive that in studying rotational motion we have to deal not only with the quantity of matter in the body, but also with the arrangement of this matter about the axis; not solely with the mass or inertia of the body, but with the importance or moment of this inertia with respect to the axis in question. We shall speak of this for the present as the **Rotational Inertia** of the body, meaning that property of the body which determines the time required for a given torque to create or destroy in the body a given amount of rotational velocity about the axis in question.

Definition of the Unit of Rotational Inertia.—Just as in the Dynamics of rectilinear motion we may agree that a body shall be said to have unit mass when unit force acting on it produces unit acceleration, so in dealing with the rotation of a rigid body it is agreed to say that the body has unit rotational inertia about the axis in question when unit torque gives it unit angular acceleration, *i.e.* adds or destroys in it, in one second, an angular velocity of one radian per sec.

If unit torque acting on the body takes, not one second, but two, to generate the unit angular velocity, then we say that the rotational inertia of the body is two units, and, speaking generally, the relation between the torque which acts, the rotational inertia of the body acted on, and the angular acceleration produced, is given by the equation

$$\text{Angular acceleration} = \frac{\text{Torque}}{\text{Rotational inertia}}$$

Just as in rectilinear motion, the impressed force, the mass

acted on, and the linear acceleration produced, are connected by the relation

$$\text{Acceleration} = \frac{\text{Force}}{\text{mass}}$$

Examples for Solution.—(1) A friction brake which exerts a constant friction of 200 pounds at a distance of 9 inches from the axis of a fly-wheel rotating 90 times a minute brings it to rest in 30 seconds. Compare the rotational inertia of this wheel with one whose rate of rotation is reduced from 100 to 70 turns per minute by a friction couple of 80 pound-foot units in 18 seconds. Ans. 25 : 24.

(2) A cord is wrapped round the axle, 8 inches in diameter, of a massive wheel, whose rotational inertia is 200 units, and is pulled with a constant force of 20 units for 15 seconds, when it comes off. What will then be the rate of revolution of the wheel in turns per minute? The unit of length being 1 foot, and of time 1 second. Ans. 4.774 turns per minute.

To calculate the Rotational Inertia of any rigid body.—We shall now show how the rotational inertia of any rigid body may be calculated when the arrangement of its particles is known.

We premise first the following:—

PROPOSITION III.—*The 'rotational inertia' of any rigid body is the sum of the 'rotational inertias' of its constituent parts.*

That this is true may be accurately ascertained by trials with the experimental wheel of Figs. 4 and 5. Let the wheel, unloaded by any sliding pieces, have its rotational inertia determined by experiment with a known torque in the manner already indicated, and call its value I_0 . Then let sliding pieces be attached in certain noticed positions, and let the new value of the rotational inertia be I_1 . Then, according to our proposition, $I_1 - I_0$ is the rotational inertia of the sliders. If this be the case, then the increase of rotational inertia

produced by the sliders in this position should be the same, whether the wheel be previously loaded or not. If trial be now made with the wheel loaded in all sorts of ways, it will be found that this is the case. The addition of the sliders in the noticed positions always contributes the same increase to the rotational inertia.

Rotational Inertia of an ideal Single-particle System.—We now proceed to consider theoretically, in the light of our knowledge of the dynamics of a particle, what must be the rotational inertia of an ideal rigid system consisting of a single particle of mass m connected by a rigid bar, whose mass may be neglected, to an axis at distance (r).

Let O be the axis, M the particle, so that $OM=r$, and let the system be acted on by a torque of L units. This we may suppose to be due to a force P acting on the particle itself, and always at right angles to the rod OM , and of such value that the moment of P is equal to the torque, *i.e.* $Pr=L$ or $P=\frac{L}{r}$.

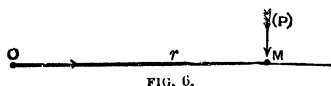

The force P acting on the mass m generates in it a linear acceleration $a=\frac{P}{m}$ in its own direction. $\frac{P}{m}$ is therefore the amount of linear speed generated per unit time by the force in its own direction, and whatever be the variations in this linear speed (v), $\frac{v}{r}$ is always equal to the rotational velocity ω , and therefore the amount of rotational velocity generated per

unit time, or the rotational acceleration, A , is $\frac{1}{r}$ th of the linear speed generated in the same time,

$$\begin{aligned} \text{i.e. } A &= \frac{P}{rm} = \frac{Pr}{mr^2} \\ &= \frac{L}{mr^2} \\ &= \frac{\text{Torque}}{mr^2}. \end{aligned}$$

But $A = \frac{\text{Torque}}{\text{rotational inertia}} ; \quad (\text{Sec p. 17.})$

\therefore The rotational inertia of a single particle of mass m at a distance r from the axis $= mr^2$.

Any rigid body may be regarded as made up of such ideal single-particle systems, and since the rotational inertia of the whole is the sum of the rotational inertias of the parts, we see that if m_1, m_2, m_3, \dots be the masses of the respective particles, r_1, r_2, r_3, \dots their distances from the axis, then

$$\begin{aligned} \text{The rotational inertia of the body} \\ &= m_1 r_1^2 + m_2 r_2^2 + m_3 r_3^2 + \dots \\ &= \Sigma(mr^2). \end{aligned}$$

This quantity $\Sigma(mr^2)$ is generally called the **Moment of Inertia** of the body. The student will now understand at once why such a name should be given to it, and the name should always remind him of the experimental properties to which it refers.

We shall from this point onward drop the term 'rotational inertia,' and use instead the more usual term 'moment of inertia,' for which the customary symbol is the letter I .

Unit Moment of Inertia.—We now see that a par le

of unit mass at unit distance from the axis has unit moment of inertia.

It is evident also that a thin circular hoop of unit radius and of unit mass rotating about a central axis perpendicular to the plane of the circle, has also unit moment of inertia; for every particle may with close approximation be regarded as at unit distance from the centre.

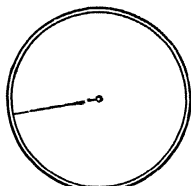

FIG. 7.



FIG. 8.

In fact,

$$\begin{aligned}
 I &= \Sigma(mr^2) \\
 &= \Sigma(m \times 1^2) \\
 &= \Sigma(m) \\
 &= 1.
 \end{aligned}$$

The same is true for any segment of a thin hoop (Fig. 8) of unit radius and unit mass, and it is also true for any thin hollow cylinder of unit radius and unit mass, rotating about its own axis.

Thus the student will find it an easy matter to prepare accurate standards of unit moment of inertia. A thin cylinder or hoop, of one foot radius and weighing 1 lb., will have the unit moment of inertia on the British absolute system. We shall call this the lb.-foot² unit. The engineer's unit is that of one slug (or 32.2 lbs.) at the distance of 1 foot, *i.e.* a slug-foot².

Definition of Angular Momentum.—Just as the product mass \times velocity, or (mv) , in translational motion is called momentum, so by analogy when a rigid body rotates about a fixed axle, the product (moment of inertia) \times (angular or rota-

tional velocity), or $(I\omega)$, is called angular or rotational momentum.* And just as a force is measured by the change of momentum it produces in unit time, so a torque about any axis is measured by the change of angular momentum it produces in unit time in a rigid body pivoted about that axis,

$$\text{for since } \Lambda = \frac{L}{I}$$

$$\therefore L = IA.$$

To find the Kinetic Energy of a rigid body rotating about a fixed axle.—At any given instant every particle is moving in the direction of the tangent to its circular path with a speed v , and its kinetic energy is therefore equivalent to $\frac{1}{2}mv^2$ units of work, and since this is true for all the particles the kinetic energy may be written $\Sigma\left(\frac{mv^2}{2}\right)$.

But for any particle the tangential speed $v=r\omega$ where r is the distance of the particle from the axis and ω is the angular velocity;

$$\therefore \text{kinetic energy} = \Sigma \frac{mr^2\omega^2}{2} \text{ units of work,}$$

and in a rigid body ω is the same for every particle;

$$\therefore \text{the kinetic energy} = \omega^2 \frac{1}{2} \Sigma (mr^2) \text{ units of work,}$$

$$= \frac{1}{2} I \omega^2 \text{ units of work.} \dagger$$

The student will observe that this expression is exactly

* When the body is not moving with simple rotation about a given fixed axis, ω is not generally the same for all the particles, and the angular momentum about that axis is then defined as the sum of the angular momenta of the particles, viz. $\Sigma(mr^2\omega)$.

† It will be remembered that the unit of work referred to will depend on the unit chosen for I . If the unit moment of inertia be that of 1 lb. at distance of one foot, then the unit of work referred to will be the foot-poundal (British Absolute System). If the unit moment of inertia be that of a 'slug' at distance of one foot, then the unit of work referred to will be the foot-pound.

analogous to the corresponding expression $\frac{1}{2}mv^2$ for the kinetic energy of translation.

Work done by a Couple.- When a couple in a plane at right angles to the fixed axis about which a rigid body is pivoted, turns the body through an angle θ , the moment of the couple retaining the same value (L) during the rotation, then the work done by the couple is $L\theta$.

For the couple is equivalent in its effect on the rotation to a single force of magnitude L acting at unit distance from the axis, and always at right angles to the same radius during the rotation.

In describing the unit angle, or 1 radian, this force advances its point of application through unit distance along the arc of the circle, and therefore does L units of work, and in describing an angle θ does $L\theta$ units of work.

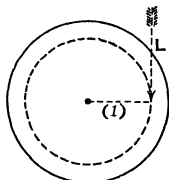

FIG. 10.

Analogy with the expression for the work done by a force, in rectilinear motion.—It will be observed that this expression for the measure of the work done by a couple is exactly analogous to that for the work done by a force in rectilinear motion, for this is measured by the product of the force and the distance through which it acts measured in the direction of the force.

If the couple be L poundal-foot units, then the work done in turning through an angle θ is $L\theta$ foot-poundals. If the couple be L pound-foot units, then the work done will be $L\theta$ foot-pounds.

Change of Kinetic Energy due to a Couple.—

When the body on which the couple acts is perfectly free to turn about a fixed axis perpendicular to the plane of the couple, it is easy to see that the work done by the couple is equal to the change in the kinetic energy of rotation.

For if A be the angular acceleration, ω_0 the initial, and ω the final value of the angular velocity, then (see equation iii. p. 4)

$$\omega^2 = \omega_0^2 + 2A\theta;$$

$$\therefore \theta = \frac{\omega^2 - \omega_0^2}{2A},$$

and $A = \frac{L}{I}$;

$$\therefore L\theta = \frac{1}{2}I\omega^2 - \frac{1}{2}I\omega_0^2$$

= Final kinetic energy — Initial kinetic energy.

Radius of Gyration.—It is evident that if we could condense the whole of the matter in a body into a single particle there would always be some distance k from the axis at which if the particle were placed it would have the same moment of inertia as the body has.

This distance is called the radius of gyration of the body with respect to the axis in question. It is defined by the relation

$$Mk^2 = \Sigma(mr^2)$$

$$k^2 = \frac{\Sigma(mr^2)}{M} = \frac{\Sigma(mr^2)}{\Sigma m},$$

M being the mass of the body and equal to the sum of the masses of its constituent particles.

[We may, if we please, regard any body as built up of a very great number (n) of equal particles, each of the same mass,

which are more closely packed together where the matter is dense, less closely where it is rare.

Then $M = nm$ and $\Sigma(mr^2) = n\Sigma r^2$,

$$\text{so that } k^2 = m \frac{\Sigma r^2}{nm} = \frac{\Sigma r^2}{n},$$

i.e. k^2 is the value obtained by adding up the squares of the distances from the axis of the several equal particles and dividing by the number of terms thus added together. That is, we may regard k^2 as the average value of the *square* of the distance from the axis to the several constituent equal particles of the rigid body.]

In a few cases, such as those of the thin hoops or thin hollow cylinder figured on p. 21, the value of the radius of gyration is obvious from simple inspection, being equal to the radius of the hoop or cylinder.

This is approximately true also for a fly-wheel of which the mass of the spokes may be neglected in comparison with that of the rim, and in which the width of the rim in the direction of a radius is small compared to the radius itself.

Numerical Examples.—We now give a number of numerical examples, with solutions, in illustration of the principles established in this chapter. After reading these the student should work for himself examples 1, 3, 6, 9, 10, 14, and 15, at the close of Chapter III.

Example 1.—*A wheel weighing 81 lbs., and whose radius of gyration is 8 inches, is acted on by a couple whose moment is 5 pound-foot units for half a minute; find the rate of rotation produced.*

1st Method of Solution.—Taking 1 lb. as unit mass. The unit force is the poundal;

$$\therefore I (= Mk^2) = 81 \times \left(\frac{8}{12}\right)^2 = 81 \times \frac{4}{9} \text{ lb.-ft.}^2 \text{ units} = 36 \text{ units.}$$

Moment of force or torque = $5 \times g$ poundal-ft. units = $5 \times 32 = 160$ units (nearly);

\therefore angular acceleration = $A = \frac{\text{torque}}{\text{moment of inertia}} = \frac{160}{36} = \frac{40}{9}$ radians per sec. each second;

\therefore the angular velocity generated in half a minute

$$= \omega = At = \frac{40}{9} \times 30 \text{ radians per sec.}$$

$$= \frac{400}{3} \text{ radians per sec.}$$

$$= \frac{400}{3} \times \frac{1}{2\pi} \text{ turns per sec.}$$

$$= \frac{400}{3} \times 1589 \text{ turns per sec.} = 1271.2 \text{ turns per minute.}$$

2nd Method of Solution.—Taking the unit of force as 1 pound, then the unit of mass is 1 slug = 32 lbs. (nearly),

\therefore the mass of the body is $\frac{81}{32}$ slugs,

$$\therefore I = Mk^2 = \frac{81}{32} \times \left(\frac{8}{12}\right)^2 = \frac{36}{32} = \frac{9}{8} \text{ slug-ft.}^2 \text{ units.}$$

Torque = 5 pound-foot units;

\therefore angular acceleration = $A = \frac{\text{torque}}{\text{moment of inertia}} = 5 \div \frac{9}{8} = \frac{40}{9}$ radians per sec. each second;

\therefore , as before, the rate of rotation produced in one half-min. = 1271.2 turns per minute.

Example 2.—Find the torque which in one minute will stop the rotation of a wheel whose mass is 160 lbs. and radius of gyration 1 ft. 6 in. and which is rotating at a rate of 10 turns per second. Find also the number of turns the wheel will make in stopping.

1st Solution.—Using British absolute units. The unit of mass is 1 lb., the unit of force 1 poundal.

$$I = Mk^2 = 160 \times \left(\frac{3}{2}\right)^2 \text{ units} = 360 \text{ units.}$$

Angular velocity to be destroyed = $\omega = 10 \times 2\pi$ radians per sec. = 20π ;

∴ this is to be destroyed in 60 sec. ; ∴ angular acceleration required
 $= \frac{20\pi}{60} = \frac{\pi}{3}$ radians per sec. each second.

The torque required to give this to the body in question

$$= \text{moment of inertia} \times \text{angular acceleration} = 360 \times \frac{\pi}{3}$$

$$= 120\pi \text{ poundal-foot units}$$

$$= \frac{120\pi}{32} = \frac{15}{4} \pi \text{ pound-ft. units.}$$

The average angular velocity during the stoppage is half the initial velocity, or 5 turns per second, therefore the number of turns made in the 60 seconds required for stopping the wheel = $60 \times 5 = 300$.

2nd Solution.—Using Engineer's or gravitation units. The unit force is 1 pound. The unit mass is 1 slug = 32 lbs. nearly.

$$I = Mk^2 = \frac{160}{32} \times \left(\frac{3}{2}\right)^2 \text{ units} = \frac{45}{4} \text{ units.}$$

The angular velocity to be destroyed = $10 \times 2\pi$ radians per sec.

The time in which it is to be destroyed is 60 sec.;

∴ angular acceleration = $A = \frac{20\pi}{60} = \frac{\pi}{3}$ radians per sec. each sec.

The torque required to give this to the body in question

$$= I \times A = \frac{45}{4} \times \frac{\pi}{3} = \frac{15}{4} \pi \text{ pound-ft. units as before.}$$

Example 3.—A cord, 8 feet long, is wrapped round the axle, 4 inches in diameter, of a heavy wheel, and is pulled with a constant force of 60 pounds till it is all unwound and comes off. The wheel is then found to be rotating 90 times a minute; find its moment of inertia.

Solution.—Using British absolute units. The unit of mass is 1 lb. and of force 1 poundal.

The force of 60 pounds = 60×32 poundals. This is exerted through a distance of 8 feet ;

∴ the work done by the force = $8 \times 60 \times 32$ ft.-poundals.

$$\text{The K.E. of rotation generated} = \frac{1}{2} I \omega^2 = \frac{1}{2} I \times \left(\frac{90 \times 2\pi}{60}\right)^2.$$

Equating the two we have

$$\frac{1}{2}I \times 9\pi^2 = 8 \times 60 \times 32 ;$$

$$\therefore I = \frac{2 \times 8 \times 60 \times 32}{9\pi^2} \text{ lb.-ft.}^2 \text{ units.}$$

It will be observed that this result is independent of the diameter of the axle round which the cord is wound, which is not involved in the solution. The torque exerted would indeed be greater if the axle were of greater diameter, but the cord would be unwound proportionately sooner, so that the angular velocity generated would remain the same.

Using Engineer's or gravitation units, the solution is as follows:—

The unit of force is 1 pound and of mass 1 slug.

The work done by the 60 pound force in advancing through 8 feet = $8 \times 60 = 480$ ft. pounds.

The K E. of rotation generated = $\frac{1}{2}I\omega^2 = \frac{1}{2}I \times \left(\frac{90 \times 2\pi}{60}\right)^2$ foot-pounds of work.

Equating the two we have

$$\frac{1}{2}I \times 9\pi^2 = 480 ;$$

$$\therefore I = \frac{2 \times 480}{9\pi^2} \text{ (slug-ft.}^2 \text{ units)}$$

$$= \frac{2 \times 480 \times 32}{9\pi^2} \text{ lb.-ft.}^2 \text{ units as before}$$

Example 4.—*A heavy wheel rotating 180 times a minute is brought to rest in 40 sec. by a uniform friction of 12 pounds applied at a distance of 15 inches from the axis. How long would it take to be brought to rest by the same friction if two small masses each weighing 1 lb. were attached at opposite sides of the axis, and at a distance of two feet from it.*

Solution.—1st. Using Engineer's or gravitation units. The unit of force is 1 pound and of mass 1 slug. In order to find the effect of increasing the moment of inertia we must first find the moment of inertia I_1 of the unloaded wheel. This is directly as the torque required to

stop it, directly as the time taken to stop it, and inversely as the angular velocity destroyed in that time. Thus

$$\begin{aligned}
 I_1 &= \frac{12 \times \frac{15}{12} \times 40}{180 \times 2\pi} \\
 &= \frac{60}{6\pi} = \frac{100}{\pi} \text{ slug-foot}^2 \text{ units.}
 \end{aligned}$$

The moment of inertia in the second case is

$$\begin{aligned}
 I_2 &= I_1 + 2mr^2 \\
 &= I + \frac{2}{g} \times 2^2 \\
 &= \frac{100}{\pi} + \frac{8}{32} \text{ approximately.}
 \end{aligned}$$

Thus the moment of inertia is increased in the ratio

$$\frac{I_2}{I_1} = \frac{\frac{100}{\pi} + \frac{8}{32}}{\frac{100}{\pi}},$$

and the time required for the same retarding torque to destroy the same angular velocity is therefore greater in this same ratio, and is now $40 \text{ sec.} + \frac{8}{32} \times \frac{\pi}{100} \times 40 \text{ sec.} = 40.31416 \text{ sec.}$

Or, using absolute units, thus

The unit of mass is 1 lb., the unit force 1 poundal—

The moment of inertia I_1 of the unloaded wheel is directly as the torque required to stop its rotation, directly as the time required, and inversely as the angular velocity destroyed in that time, and is equal

$$\text{to } \frac{12 \times 32 \times \frac{15}{12} \times 40}{180 \times 2\pi} \text{ lb.-ft.}^2 \text{ units,}$$

$$\begin{aligned}
 \text{or } I_1 &= \frac{32 \times 15 \times 40 \times 60}{3 \times 2\pi} \text{ units (approximately)} \\
 &= \frac{3200}{\pi} \text{ lb.-ft.}^2 \text{ units.}
 \end{aligned}$$

The moment of inertia in the second case

$$= I_2 = I_1 + 2mr^2 = \frac{3200}{\pi} + 8;$$

∴ the moment of inertia is increased in the ratio of

$$\frac{3200}{\pi} + 8 : \frac{3200}{\pi};$$

and therefore the time required for the same retarding torque to destroy the same angular velocity is increased in the same proportion, and is now

$$40 \text{ sec.} + 40 \text{ sec.} \times \frac{8 \times \pi}{3200} = 40.31 \text{ sec. approximately (as before).}$$

Note to Chapter II.

In order to bring the substance of this chapter with greater vividness and reality before the mind of the student, we have preferred to take it as a matter of observation and experiment that the power of a force to produce angular acceleration in a rigid body pivoted about a fixed axle is proportional to the product of the force and its distance from the axis, *i.e.* to its moment in the technical sense. But this result, together with the fact that what we termed the 'rotational inertia' of a body is given by $\Sigma(mr^2)$, might have been obtained as a direct deduction from Newton's Laws of Motion. We now give this deduction, premising first a statement of **d'Alembert's Principle**, which may be enunciated as follows: 'In considering the resultant mass-acceleration produced in any direction in the particles of any material system, it is only necessary to consider the values of the *external* forces acting on the system.'

For every force is to be measured by the mass-acceleration it produces in its own direction (Newton's Second Law of Motion), and also every force acts between two portions of matter and is accompanied by equal and opposite reaction, producing an equal and opposite mass-acceleration (Newton's Third Law). The action and reaction constitute what we call a stress. When the two portions of matter, between which a stress acts, are themselves parts of the system, it follows that the resultant mass-acceleration thereby produced in the system is zero. The stress is in this case called an *internal stress*, and the two forces *internal forces*. But though the forces are internal to the system, yet they are external, or, as Newton

called them, 'impressed' forces on the two particles respectively. Hence, considering Newton's Second Law of Motion to be the record solely of observations on *particles* of matter, we may count up the forces acting in any direction on any material system and write them equal to the sum of the mass-accelerations in the same direction, but in doing so we ought, in the first instance at any rate, to include these internal forces, thus

$$\Sigma \left(\begin{array}{l} \text{external forces} \\ \text{in any direction} \end{array} \right) + \Sigma \left(\begin{array}{l} \text{internal forces} \\ \text{in same direction} \end{array} \right) = \Sigma \left(\begin{array}{l} \text{mass-accelerations} \\ \text{in same direction} \end{array} \right)$$

We now see that $\Sigma(\text{internal forces}) = 0$.

Hence we obtain as a deduction

$$\Sigma \left(\begin{array}{l} \text{external forces} \\ \text{in any direction} \end{array} \right) = \Sigma \left(\begin{array}{l} \text{mass-accelerations} \\ \text{in same direction} \end{array} \right),$$

or $\Sigma E = \Sigma(ma)$.

This justifies the extension of Newton's law from particles to bodies or systems of particles. If any forces whatever act on a free rigid body, then whether the body is thereby caused to rotate or not, the sum of the mass-accelerations in any direction is equal to the sum of the resolutives of the applied forces in the same direction.

Now, since the line of action of a force on a particle is the same as the line of the mass-acceleration, we may multiply both the force and the mass-acceleration by the distance r of this line from the axis, and thus write

$$\left. \begin{array}{l} \text{the moment about any axis of} \\ \text{the force, on any particle,} \\ \text{along any line,} \end{array} \right\} = \left\{ \begin{array}{l} \text{moment of the mass-accelera-} \\ \text{tion, along that line, of the} \\ \text{same particle,} \end{array} \right.$$

and, therefore, summing up the results for all the particles of any system, we have

$$\Sigma \left\{ \begin{array}{l} \text{moments about any axis of} \\ \text{all the forces acting on the} \\ \text{particles of the system} \end{array} \right\} = \Sigma \left\{ \begin{array}{l} \text{moments about the same} \\ \text{axis of the mass-accele-} \\ \text{rations of the particles,} \end{array} \right\}$$

or $\Sigma \left(\begin{array}{l} \text{moments of the external} \\ \text{forces} \end{array} \right) + \Sigma \left(\begin{array}{l} \text{moments of the internal} \\ \text{forces} \end{array} \right)$
 $\qquad\qquad\qquad = \Sigma \left(\begin{array}{l} \text{moments of the mass-} \\ \text{accelerations.} \end{array} \right)$

Now, not only are the two forces of an internal stress between two

particles equal and opposite, but they are *along the same straight line*,* and hence have equal and opposite moments about any axis whatever, hence the second term on the left side of the above equation is always zero, and we are left with

$$\Sigma \left(\begin{array}{l} \text{moments of the external} \\ \text{forces} \end{array} \right) = \Sigma \left(\begin{array}{l} \text{moments of the mass-} \\ \text{accelerations.} \end{array} \right)$$

Now, we may resolve the acceleration of any particle into three rectangular components, one along the radius drawn from the particle perpendicular to the axis, one parallel to the axis, and one perpendicular to these two. It is only this latter component (which we will call a_p) that has any moment about the axis in question, and its moment is ra_p , where r is the length of the radius.

Thus the moment of the mass-acceleration of any particle of mass m may be written ma_p .

Now, in the case of a particle which always retains the same distance (r) from the axis, a_p is the rate of increase of the tangential speed v , and if ω be the angular velocity about the axis, $v=r\omega$. So that a_p = rate of increase of $r\omega$.

Also, r being constant, the rate of increase of $r\omega$ is r times the rate of increase of ω . Hence, *in this case*, $a_p=r\dot{\omega}$, and if, further, the whole system consists of particles so moving, and with the same angular velocity, *i.e.* if it is a rigid body rotating about a fixed axle, then *for such a body so moving*

$$\begin{aligned} \Sigma (\text{moments of the mass-accelerations}) &= \Sigma mr \cdot r\dot{\omega}. \\ &= \dot{\omega} \Sigma mr^2. \end{aligned}$$

Hence, *in this case*

$$\Sigma (\text{moments of the external forces}) = \text{angular acc}^n \times \Sigma (mr^2)$$

$$\text{or the angular acceleration} = \frac{\text{External torque}}{\Sigma (mr^2)}.$$

* This is, perhaps, not explicitly stated by Newton, but if it were not true, then the action and reaction between two particles of a rigid body would constitute a couple giving a perpetually increasing rotation to the rigid body to which they belonged, and affording an indefinite supply of energy. No such instance has been observed in Nature.

CHAPTER III.

DEFINITIONS, AXIOMS, AND ELEMENTARY THEOREMS NECESSARY FOR DEALING WITH MOMENTS OF INERTIA.
ROUTH'S RULE AND ITS APPLICATION.

CONSTANT use will be made of the following Definitions and Propositions.

DEFINITION.—By a slight extension of language we speak of the *moment of inertia of a given area* with respect to any axis, meaning the moment of inertia which the figure would have if cut out of an indefinitely thin, perfectly uniform rigid material of unit mass per unit area, so that the mass of the figure is numerically equal to its area. This dynamical definition becomes purely geometrical, if we say that the moment of inertia, with respect to any axis, of an area A , and of which the indefinitely small parts a_1, a_2, a_3, \dots are at distance r_1, r_2, \dots from the axis, is equal to

$$a_1 r_1^2 + a_2 r_2^2 + a_3 r_3^2 + \dots \\ = \Sigma(ar^2).$$

It will be observed that the area may be either plane or curved.

DEFINITION.—In the same way the moment of inertia about any axis of any solid figure or volume V , of which v_1, v_2, v_3, \dots are the indefinitely small constituent parts, may be defined as

$$v_1 r_1^2 + v_2 r_2^2 + \dots \\ = \Sigma(vr^2).$$

AXIOM.—The moment of inertia of a body with respect to any axis is the sum of the moments of inertia of *any* constituent parts into which we may conceive it divided, and similarly the moment of inertia with respect to any axis of any given surface or volume is equal to the sum of the moments of inertia of any constituent parts into which we may conceive the surface or volume divided. This follows from the definitions just given.

ILLUSTRATION.—Thus the moment of inertia of a peg-top, shaped as in the figure, about its axis of revolution, is equal to the moment of inertia of the hemispherical dome of wood ABC+that of the conical frustum ABDE+that of the conical point of steel DE.

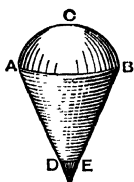

FIG. 11.

AXIOM.—It is evident that the radius of gyration of any right prism of uniform density about any axis perpendicular to its base is the same as that of the base. For we may conceive the solid divided by an

indefinite number of parallel planes into thin slices, each of the same shape as the base.

Thus, if k be radius of gyration of the basal figure, and M the mass of the prism, the moment of inertia is Mk^2 units, and this holds whether the axis cuts the figure as $O_2O'_2$, or does not cut it as $O_1O'_1$.

Thus the problem of finding the moment of inertia of an ordinary lozenge-shaped compass needle, such as that figured, reduces to that

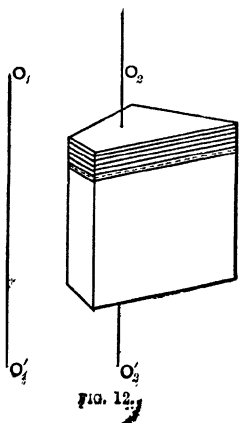

FIG. 12.

of finding the radius of gyration about OO' of the horizontal cross-section $ABCD$.

PROPOSITION I.—*The moment of inertia of a lamina about any axis Oz perpendicular to its plane, is equal to the sum of its moments of inertia about any two rectangular axes Ox and Oy in its plane, and intersecting at the point O where the axis Oz meets the plane of the lamina. Or, in an obvious notation,*

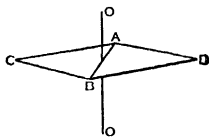

FIG. 13.

$$I_z = I_x + I_y.$$

Proof.—From the figure we have at once

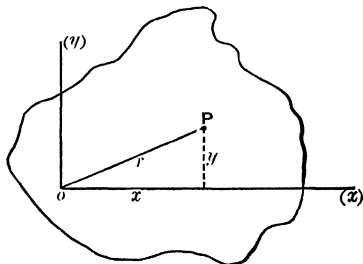

FIG. 14.

$$\begin{aligned} I_z &= \Sigma(mr^2) \\ &= \Sigma m(x^2 + y^2) \\ &= \Sigma mx^2 + \Sigma my^2 \\ &= I_y + I_x. \end{aligned}$$

Example.—We have already seen that a thin hoop of radius r and mass m has a moment of inertia Mr^2 about a central axis perpendicular to its plane.

Let I be its moment of inertia about a diameter. Then I is also its moment of inertia about a second diameter perpendicular to the former; \therefore by this proposition

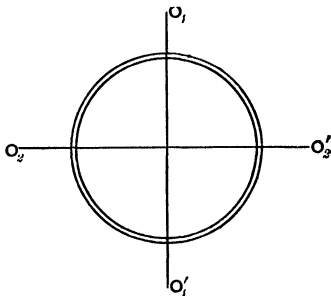

FIG. 15.

$$\begin{aligned} 2I &= Mr^2; \\ \therefore I &= \frac{Mr^2}{2}, \end{aligned}$$

i.e., the moment of inertia of a hoop about a diameter is only half that about a central axis perpendicular to the plane of the hoop.

Routh's Rule for finding the Moment of Inertia about an Axis of Symmetry in certain cases.—When the axis about which the moment of inertia is required passes through the centre of figure of the body and is also an axis of symmetry, then the value of the moment of inertia in a large number of simple cases is given by the following rule of Dr. Routh:—

Moment of inertia about an axis of symmetry

$$= \text{Mass} \times \frac{\text{sum of the squares of the perpendicular semi-axes}}{3, 4, \text{ or } 5},$$

$$\text{or } k^2 = \frac{\text{sum of the squares of the perpendicular semi-axes}}{3, 4, \text{ or } 5}.$$

The denominator is to be 3, 4, or 5, according as the body is a rectangle, ellipse (including circle), or ellipsoid (including sphere).

This rule is simply a convenient summary of the results obtained by calculation. The calculation of the quantity $\Sigma(mr^2)$ is, in any particular case, most readily performed by the process of integration, but the result may also be obtained, in some cases, by simple geometry. We give in Chapter IV. examples of the calculation in separate cases, and it will be seen that they are all rightly summarised by the rule as given.

Examples of the Application of Dr. Routh's Rule.—To find the radius of gyration in the following cases:—

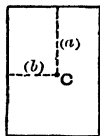

FIG. 16.

(1) *Of a rectangle of sides (2a) and (2b) about a central axis perpendicular to its plane.*

Here the semi-axes, perpendicular to each other and to the axis in question, are a and b ; therefore, applying the rule, we have

$$k^2 = \frac{a^2 + b^2}{3}.$$

(2) *Of the same rectangle about a central axis in its plane perpendicular to one side (b).* Here the semi-axes, perpendicular to

each other and to the axis in question, are b and 0 (see fig. 17), (since the figure has no dimensions perpendicular to its own plane);

$$\therefore k^2 = \frac{b^2 + 0^2}{3} = \frac{b^2}{3}.$$

(3) *Of a circular area of radius r about a central axis perpendicular to its plane.* Here the semi-axes, perpendicular to each other and to the axis of symmetry in question, are r and r ;

• applying Routh's rule

$$k^2 = \frac{r^2 + r^2}{4} = \frac{r^2}{2}.$$

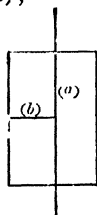

FIG. 17.

(4) *Of a circular area about a central axis in the plane of the circle.* The semi-axes, perpendicular to each other and to the axis in question, are r and 0 ;

• applying Routh's rule

$$k^2 = \frac{r^2 + 0^2}{4} = \frac{r^2}{4}.$$

(5) *Of uniform sphere about any central axis*

$$k^2 = \frac{r^2 + r^2}{5} = \frac{2}{5}r^2.$$

(6) *The moment of inertia of a uniform thin rod about a central axis perpendicular to its length.*

$$I = \text{Mass} \times \frac{r^2 + 0^2}{3} = \text{Mass} \times \frac{r^2}{3}.$$

Theorem of Parallel Axes.—When the moment of inertia of any body about an axis through the centre of mass (coincident with the centre of gravity*) is known, its moment of

* The centre of gravity of a body or system of heavy particles is defined in statics as the centre of the parallel forces constituting the weights of the respective particles, and its distance \bar{x} from any plane is shown to be given by the relation

$$\bar{x} = \frac{w_1x_1 + w_2x_2 + w_3x_3 + \dots + w_nx_n}{w_1 + w_2 + \dots + w_n}$$

or $\bar{x} = \frac{\Sigma(wx)}{\Sigma w}$,

Dynamics of Rotation.

inertia about any parallel axis can be found by applying the following proposition :—

PROPOSITION II.—*The moment of inertia of any body about any axis is equal to its moment of inertia about a parallel axis through its centre of mass, plus the moment of inertia which the body would have about the given axis if all collected at its centre of mass.*

Thus, if I be the moment of inertia about the given axis, I_g that about the parallel axis through the centre of mass, and R the distance of the centre of gravity from the given axis, and M the mass of the body.

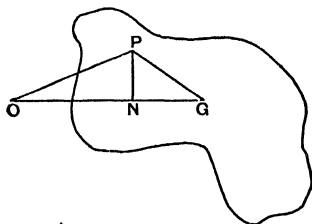

FIG. 18.

$$I = I_g + MR^2.$$

Proof.—Let the axis of rotation cut the plane of the diagram in O , and let a parallel axis through the centre of mass (or centre of gravity) of the body

cut the same plane in G , and let P be the projection on this

where $w_1, w_2 \dots$ are the weights of the respective particles, and $x_1, x_2 \dots$ their distances from the plane in question.

Now, since the weight (w) of any piece of matter is found by experiment to be proportional to its mass or inertia (m), we may substitute (m) for (w) in the above equation, and we thus obtain

$$\bar{x} = \frac{\Sigma(mx)}{\Sigma m}.$$

For this reason the point in question is also called the centre of mass, or centre of inertia.

If the weight of (*i.e.* the earth-pull on) each particle were *not* proportional to its mass, then the distance of the centre of gravity from any plane would still be $\frac{\Sigma(wx)}{\Sigma w}$; but the distance of the centre of mass from the same plane would be $\frac{\Sigma(mx)}{\Sigma m}$ and the two points would *not* then coincide.

plane of any particle of the body. Let m be the mass of the particle. OP and GP are projections of the radii from the two axes respectively. Let PN be perpendicular to OG . Then, since

$$\begin{aligned} OP^2 &= OG^2 + GP^2 - 2OG \cdot GN; \\ \therefore \Sigma(mOP^2) &= \Sigma(mOG^2) + \Sigma(mGP^2) - 2OG \cdot \Sigma(mGN) \\ &= M OG^2 + \Sigma(mGP^2) - 0, \end{aligned}$$

for, since G is the projection of the centre of mass, the positive terms in the summation $\Sigma(mGN)$ must cancel the negative. (The body in fact would balance about any line through G .)

Thus,
$$I = MR^2 + I_g.$$

APPLICATIONS.—(1) *To find the moment of inertia of a door about its hinges.*

Regarding the door as a uniform thin lamina of breadth a and mass M , we see that its moment of inertia, about a parallel axis through its centre of gravity, is

$$\begin{aligned} I_g &= M \frac{\left(\frac{a}{2}\right)^2 + 0^2}{3} = M \frac{a^2}{12}; \\ \therefore I &= M \frac{a^2}{12} + M \left(\frac{a}{2}\right)^2 = M \frac{a^2}{3}. \end{aligned}$$

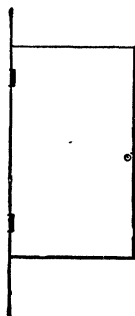

FIG. 19.

(2) *To find the moment of inertia of a uniform circular disc about a tangent in its plane.*

$$\begin{aligned} I_g &= M \frac{r^2 + 0^2}{4} \text{ (by Routh's rule),} \\ \text{and } I &= I_g + Mr^2 \\ &= M \left(\frac{r^2}{4} + r^2\right) = M \frac{5}{4} r^2. \end{aligned}$$

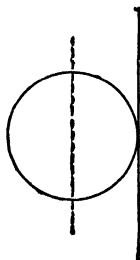

FIG. 20.

(3) *To find the moment of inertia of a uniform*

Dynamics of Rotation.

bar or other prism about a central axis perpendicular to its length, where the bar is not thin.



FIG. 21.

(For example of a bar-magnet of circular cross-section suspended by a fine thread as in the fig.)

For the sake of being able to deal with a case like this, which is of very common occurrence, we shall prove the following:—

PROPOSITION III.—*The moment of inertia of any uniform right prism, of any cross section whatever about a central axis perpendicular to the line joining the centres of gravity of the ends, is equal to the moment of inertia of the same prism considered as a thin bar, plus the moment of inertia that the prism would have if condensed by endwise contraction into a single thin slice at the axis.*

Proof.—Let $g, g_1,$ be the centres of gravity of the ends of the prism.

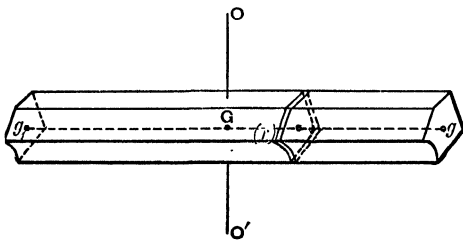

FIG. 22.

Imagine the prism divided into an indefinite number of elementary thin slices by planes parallel to the ends. The

line g, g_1 , contains the centre of gravity of each slice and of the whole prism. Let r be the distance of any one of these slices from the centre of gravity (G) of the whole prism, and m the mass of the slice. Then the moment of inertia i of this slice about the given axis OO' is, by the theorem of parallel axes, given by

$$i = i_s + mr^2,$$

where i_s is the moment of inertia of the slice about a parallel axis through its centre of gravity ;

\therefore the whole moment of inertia I required is

$$\begin{aligned} I &= \Sigma(i_s + mr^2) \\ &= \Sigma i_s + \Sigma mr^2, \end{aligned}$$

and Σi_s is the same as the moment of inertia I_s of all the slices condensed into a single slice ; thus the proposition is proved.

This theorem is of use in questions involving the oscillations of a cylindrical bar magnet under the influence of the horizontal component of the earth's magnetic force.

Examples for Solution.

(In these, as in all other Examples in the book, the answers given are approximate only. Unless otherwise stated, the value of g is taken as 32 feet per second each second, instead of 32.19.)

(1) A heavy wheel has a cord 10 feet long coiled round the axle. This cord is pulled with a constant force of 25 pounds till it is all unwound and comes off. The wheel is then found to be rotating 5 times a second. Find its moment of inertia. Also find how long a force of 5 pounds applied at a distance of 3 inches from the axis would take to bring the wheel to rest.

Ans. (1) 16.2 lb.-ft.² units.
(2) 12.72 sec.

(2) A uniform door 8 feet high and 4 feet wide, weighing 100 lbs., swings on its hinges, the outer edge moving at the rate of 8 feet per second. Find (1) the angular velocity of the door, (2) its moment of inertia with respect to the hinges, (3) its kinetic energy in foot-pounds, (4) the pressure in pounds which when applied at the edge, at right angles to the plane of the door, would bring it to rest in 1 second.

Ans. (1) 2 radians per sec.
(2) 533.3 lb.-ft.² units.
(3) 33.3 (nearly).
(4) 8.3 pounds (nearly).

(3) A drum whose diameter is 6 feet, and whose moment of inertia is equal to that of 40 lbs. at a distance of 10 feet from the axis, is employed to wind up a load of 500 lbs. from a vertical shaft, and is rotating 120 times a minute when the steam is cut off. How far below the shaft-mouth should the load then be that the kinetic energy of wheel and load may just suffice to carry the latter to the surface?

Ans. 41.9 feet (nearly).

(4) Find the moment of inertia of a grindstone 3 feet in diameter and 8 inches thick; the specific gravity of the stone being 2.14.

Ans. 709.3 lb.-ft.² units.

(5) Find the kinetic energy of the same stone when rotating 5 times in 6 seconds. Ans. 303·7 ft.-pounds.

(6) Find the kinetic energy of the rim of a fly-wheel whose external diameter is 18 feet, and internal diameter 17 feet, and thickness 1 foot, and which is made of cast-iron of specific gravity 7·2, when rotating 12 times per minute.

(N.B.—Take the mean radius of the rim, viz. 8½ feet, as the radius of gyration.) Ans. 23360 ft.-pounds (nearly).

(7) A door 7½ feet high and 3 feet wide, weighing 80 lbs., swings on its hinges so that the outward edge moves at the rate of 8 feet per sec. How much work must be expended in stopping it?

Ans. 853·3 foot-pounds or 26·67 foot-pounds (very nearly).

(8) In an Atwood's machine a mass (M) descending, pulls up a mass (m) by means of a fine and practically weightless string passing over a pulley whose moment of inertia is I, and which may be regarded as turning without friction on its axis. Show that the acceleration a of either weight and the tensions T and t of the cord at the two sides of the pulley are given by the equations

$$a = \frac{Mg - T}{M} \quad . \quad . \quad . \quad (i)$$

$$a = \frac{t - mg}{m} \quad . \quad . \quad . \quad (ii)$$

$$a = r\dot{\omega} = \frac{r^2(T - t)}{I} \quad . \quad . \quad . \quad (iii)$$



where r = radius of pulley.

What will equation (iii) become if there is a constant friction of moment (l) about the axis?

$$\text{Ans. } a = \frac{r^2(T - t - \frac{l}{r})}{I}.$$

(9) A wheel, whose moment of inertia is 50 lb.-ft.² units, has a horizontal axle 4 inches in diameter round which a cord is wrapped, to which a 10 lb. weight is hung. Find how long the weight will take to descend 12 feet. Ans. 11·65 sec. (nearly).

Directions.—Let time required = t sec. Then the average velocity during the descent is $\frac{12}{t}$ feet per sec., and since this has been acquired

at a uniform rate the final velocity of the weight is *twice* this. Knowing now the final velocity (v) of the cord and the radius (r) of the axle we have the angular velocity $\omega = \frac{v}{r}$ of the wheel at the end of the descent, and can now express the kinetic energies of both weight and wheel. The sum of these kinetic energies is equal to the work done by the earth's pull of 10 pounds acting through 12 feet, i.e. to 12×10 foot-pounds or $12 \times 10 \times 32$ foot-pounds. This equality enables us to find t .

(10) Find the moment of inertia of a wheel and axle when a 20 lb. weight attached to a cord wrapped round the axle, which is horizontal and 1 foot in diameter, takes 10 sec. to descend 5 feet.

Ans. 1595 lb.-ft.² units.

Directions.—Let the moment of inertia required be I lb.-ft.² units.

The average linear velocity of the weight is $\frac{5}{10}$ f.s.

Hence final = $\frac{2 \times 5}{10}$ f.s. = 1 f.s. = v .

Angular velocity (ω) = $\frac{\text{space traversed per sec. by point on circumference of axle}}{\text{radius of axle}}$
 $= \frac{1}{\frac{1}{2}} = 2$.

Now equate sum of kinetic energies of weight and wheel to work done by earth's pull during the descent.

(11) A cylindrical shaft 4 inches in diameter, weighing 80 lbs., turns without appreciable friction about a horizontal axis. A fine cord is wrapped round it by which a 20 lb. weight hangs. How long will the weight take to descend 12 feet? Ans. $t = 1.50$ sec.

(12) If there were so much friction as to bring the shaft of the previous question to rest in 2 seconds from a rotation of 10 turns per sec., what would the answer have been? Ans. $1.50 \text{ sec.} \times \sqrt{\frac{680}{5167}}$.

(13) Two weights, of 3 lbs., and 5 lbs., hang over a fixed pulley in the form of a uniform circular disc, whose weight is 12 oz. Find the time taken by either weight to move from rest through $\frac{9}{8}$ feet. Ans. $\frac{1}{2}$ sec.

(14) Find the moment of inertia of a fly-wheel from the following data:—The wheel is set rotating 80 times a minute, and is then thrown out of gear and brought to rest in 3 minutes by the pressure

of a friction brake on the axle, which is 18 inches in diameter. The normal pressure of the brake, which has a plane surface, is 200 pounds, and the coefficient of friction between brake and axle is $\cdot 6$.

Ans. 61890 lb.-ft.² units.

(15) Prove that when a model of any object is made of the same material, but on a scale n times less, then the moment of inertia of the real object is n^5 times that of the model about a corresponding axis.

(16) Show that, on account of the rotation of each wheel of a carriage, the effective inertia is increased by an amount equal to the moment of inertia divided by the square of the radius.

(17) A wheel on a frictionless axle has its circumference pressed against a travelling band moving at a speed which is maintained constant. Prove that when slipping has ceased as much energy will have been lost in heat as has been imparted to the wheel.

CHAPTER IV.

MATHEMATICAL PROOFS OF THE DIFFERENT CASES INCLUDED UNDER ROUTH'S RULE.

THIS chapter is written for those who are not satisfied to take the rule on trust. In several cases the results are obtained by elementary geometry.

On the Calculation of Moments of Inertia.—In the previous chapter we quoted a 'rule' which summarised the results of calculation in various cases. We now give, in a simple form, the calculation itself for several of the cases covered by the rule.

(1) *To find I for a uniform thin rod of length (R) and mass (m), per unit length, about an axis through one end perpendicular to the rod.*

Let AB be the rod, OAO' the axis.

Through B draw BC perpendicular to the plane OAB and equal to AB . On BC , in a plane perpendicular to AB , describe the square $BCDE$. Join A to the angles E, D, C , of the square. Conceive the pyramid thus formed,

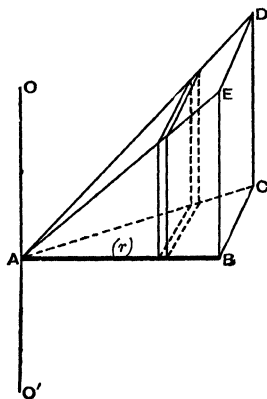

FIG. 23.

E, D, C , of the square.

Conceive the circle divided into an indefinitely large number of very small sectors (fig. 26), and let i be the moment of inertia of any one of these, then Σi will be the moment of inertia of the whole circle.

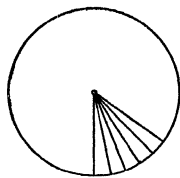

FIG. 26.

Each sector may be regarded as an isosceles triangle of altitude r , and base very small in comparison, and for such a triangle i is easily shown* to be equal to $m \frac{r^2}{2}$

* The proof may be given as follows:—Let the base BC of any isosceles ΔABC be of length $2l$, and the altitude AD be r . Let g be the centre of gravity of ADC. Complete the parallelogram ADCF. The moment of inertia i of this parallelogram, about an axis through its centre of gravity F, perpendicular to its plane is

$$m \frac{\left(\frac{r}{2}\right)^2 + \left(\frac{l}{2}\right)^2}{3} = m \frac{r^2 + l^2}{12} \text{ where}$$

m = mass of parallelogram and therefore of ΔABC .

By symmetry i_F for the ΔADC is half this

$$= \frac{m}{2} \frac{r^2 + l^2}{12}$$

FIG. 27.

By the theorem of parallel axes

$$i_A = i_F - \frac{m}{2} (\overline{Fg})^2 = \frac{m}{2} \frac{r^2 + l^2}{12} - \frac{m}{2} \frac{r^2 + l^2}{36} = \frac{m}{2} \frac{r^2 + l^2}{18}$$

$$\text{and } i_A = i_A + \frac{m}{2} (\overline{Ag})^2 = \frac{m}{2} \frac{r^2 + l^2}{18} + \frac{m}{2} \frac{4}{9} \left\{ r^2 + \left(\frac{l}{2}\right)^2 \right\}$$

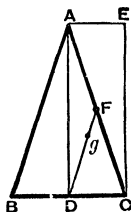
$$= \frac{m}{2} \left(\frac{r^2}{2} + \frac{l^2}{6} \right)$$

$= \frac{m}{2} \frac{r^2}{2}$ when l is sufficiently small in comparison with r .

$\therefore i_A$ for the whole $\Delta ABC = m \frac{r^2}{2}$ when the base is very small compared with the altitude r . This is the value made use of in the proposition.

where m is the mass of the triangle.

$$\begin{aligned}\therefore I &= \Sigma i = \Sigma \frac{mr^2}{2} \\ &= \frac{r^2}{2} \Sigma m \\ &= \frac{r^2}{2} \times M,\end{aligned}$$

which is the value given by Routh's rule.

Each of these results would have been obtained much more briefly by integration. Thus, for a uniform thin rod of length, $2l$ and mass M turning about a central axis perpendicular to its length, the moment of inertia of any elementary length, dr at distance r

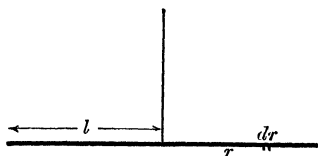

FIG. 28.

$$= \text{mass of element} \times r^2$$

$$= M \times \frac{dr}{2l} \times r^2$$

$$\begin{aligned}\therefore \text{moment of inertia of whole rod} &= \int_{r=-l}^{r=l} \frac{M}{2l} r^2 dr \\ &= M \frac{l^2}{3}.\end{aligned}$$

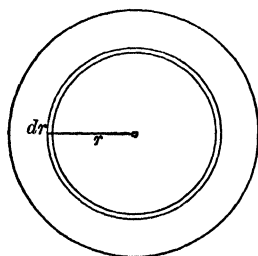

FIG. 29.

In the case of a uniform circular disc of mass M and radius a turning about a central axis perpendicular to its plane, we may conceive it divided into a succession of elementary concentric annuli, each

of breadth dr . If r be the radius of one of these, its moment of inertia

$$\begin{aligned} &= \text{mass of annulus} \times r^2 \\ &= M \times \frac{2\pi r dr}{\pi a^2} \times r^2 \\ &= \frac{2M}{a^2} r^3 dr \end{aligned}$$

$$\therefore I = \frac{2M}{a^2} \int_{r=0}^{r=a} r^3 dr = \frac{Ma^2}{2}.$$

Moment of Inertia of an Ellipse.—This is readily obtained from that of the circle. For the circle ABC of radius a becomes the ellipse ADC with semi-

axes a and b by projection, every length in the circle parallel to OB being diminished in the ratio $\frac{OD}{OB} = \frac{b}{a}$ while lengths parallel to OA remain unaltered. Thus any elementary area in the circle is diminished in the ratio $\frac{b}{a}$ and at the same time brought nearer

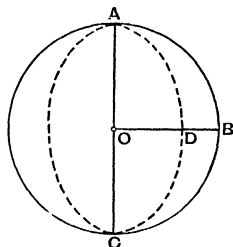

FIG. 80.

to OC in the same ratio.

Hence

Moment of inertia of ellipse about major axis = moment of

$$\begin{aligned} \text{inertia of circle about same axis} &\times \frac{b}{a} \times \frac{b^2}{a^2} \\ &= \frac{Ma^2}{4} \times \frac{b}{a} \times \frac{b^2}{a^2} \\ &= M \times \frac{b}{a} \times \frac{b^2}{4} \\ &= \text{Mass of ellipse} \times \frac{b^3}{4}. \end{aligned}$$

The moment of inertia of the ellipse about the minor axis is evidently equal to that of the circle $\times \frac{b}{a}$, for each elementary area of the ellipse is at the same distance from this axis as the corresponding area of the circle, but is reduced in magnitude in the ratio $\frac{b}{a}$.

Hence

Moment of inertia of ellipse about minor axis

$$\begin{aligned} &= \frac{Ma^2}{4} \times \frac{b}{a} \\ &= M \frac{b}{a} \times \frac{a^3}{4} \\ &= \text{Mass of ellipse} \times \frac{a^3}{4}. \end{aligned}$$

Combining these two results by Proposition I. p. 35, we obtain, moment of inertia of ellipse about a central axis perpendicular to its plane $= M \frac{a^2 + b^2}{4}$.

In Hicks' *Elementary Dynamics* (Macmillan), p. 346, a geometrical proof is given for the moment of inertia of a sphere, and, on p. 339 of the same work, that of a right cone about its axis is shown geometrically to be $\frac{3}{10}Mr^2$, where r is the radius of the base. The proof for the sphere is, however, so much more readily obtained by integration that we give it below.

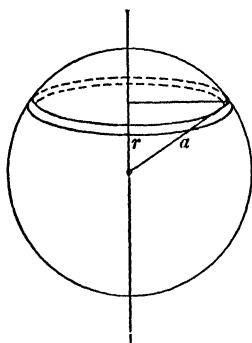

FIG. 31

We conceive the sphere divided into elementary circular slices by

planes perpendicular to the diameter, about which the moment of inertia is sought, each slice being of the same elementary thickness dr .

If r be the distance of any such slice from the centre, its moment of inertia about the said diameter is

$$\begin{aligned} & \text{mass of slice} \times \frac{(\text{radius})^2}{2} \\ &= M \times \frac{\pi(a^2 - r^2)dr}{\frac{4}{3}\pi a^3} \times \frac{a^2 - r^2}{2} \\ \therefore I &= \frac{3M}{8a^3} \int_{r=-a}^{r=a} (a^2 - r^2)^2 dr \\ &= \frac{3M}{8a^3} \left(2a^5 - \frac{4}{3}a^5 + \frac{2}{5}a^5 \right) \\ &= \frac{3M}{8a^3} \times \frac{16}{15}a^5 \\ &= M \times \frac{2}{5}a^2 \\ &= M \frac{a^2 + a^2}{5} \text{ as stated in Routh's Rule.} \end{aligned}$$

The student who is acquainted with the geometry of the ellipsoid will perceive that the moment of inertia of an ellipsoid may be obtained from that of the sphere by projection, in the same way that we obtained the result for the ellipse from that of the circle.

Exercises.—Find the radius of gyration of—

(1.) A square of side a about a diagonal.

$$\text{Ans. } k^2 = \frac{a^2}{12}$$

(2.) A right-angled triangle of sides a and b , containing the right-angle about the side a .

$$\text{Ans. } k^2 = \frac{b^2}{6}$$

(3.) An isosceles triangle of base b about the perpendicular to the base from the opposite angle.

$$\text{Ans. } k^2 = \frac{b^2}{24}.$$

(4.) A plane circular annulus of radii R and r about a central axis perpendicular to its plane.

$$\text{Ans. } k^2 = \frac{R^2 + r^2}{2}.$$

(5.) A uniform spherical shell of radii R and r about a diameter.

$$\text{Ans. } k^2 = \frac{2}{5} \frac{R^5 - r^5}{R^3 - r^3}.$$

Directions.—Write (M) = mass of outer sphere, supposed solid; (m) that of inner. Moment of inertia of shell $= (M - m)k^2 =$ difference between the moments of inertia of the two spheres. Also since $\frac{m}{M} = \frac{r^3}{R^3}$, we have $m = M \frac{r^3}{R^3}$ and $M - m = M \frac{R^3 - r^3}{R^3}$. Thus all the masses can be expressed in terms of one, which then disappears from the equation.

(6) Prove that the moment of inertia of a uniform, plane, triangular lamina about any axis, is the same as that of 3 equal particles, each one-third of the mass of the lamina, placed at the mid-points of the sides.

CHAPTER V.

FURTHER PROPOSITIONS CONCERNING MOMENTS OF INERTIA
—PRINCIPAL AXES—GRAPHICAL CONSTRUCTION OF IN-
ERTIA CURVES AND SURFACES—EQUIMOMENTAL SYSTEMS
—INERTIA SKELETONS.

WE have shown in Chapters III. and IV. how to obtain the moments of inertia of certain regular figures about axes of symmetry, and axes parallel thereto. The object of the present chapter is to acquaint the student with certain important propositions applicable to rigid bodies of any shape, and by means of which the moment of inertia about other axes can be determined. The proofs given require the application of only elementary solid geometry ; but should the student find himself unable to follow them, he is recommended, at a first reading of the subject, to master, nevertheless, the meaning of the propositions enunciated and the conclusions reached, and not to let the geometrical difficulty prevent his obtaining a knowledge of important dynamical principles.

PROPOSITION IV.—*In any rigid body, the sum of the moments of inertia about any three rectangular axes, drawn through a given point fixed in the body, is constant, whatever be the positions of the axes.*

Let Ox , Oy , Oz , be any three rectangular axes drawn through the fixed point O . Let P be any particle of the body

and of mass (m), and co-ordinates x, y, z . Let $OP = r$, and

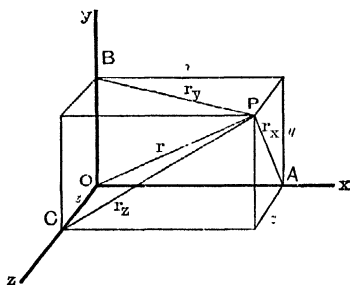

FIG. 23A.

let the distances AP, BP, CP , of P from the axes of x, y and z respectively, be called r_x, r_y , and r_z .

Then the moment of inertia of the particle P

about x is $mr_x^2 = m(y^2 + z^2)$,

„ y is $mr_y^2 = m(z^2 + x^2)$,

„ z is $mr_z^2 = m(x^2 + y^2)$,

therefore, for the whole body,

the moment of inertia about the axis of x , or $I_x = \Sigma my^2 + \Sigma mz^2$

„ „ „ „ y , or $I_y = \Sigma mz^2 + \Sigma mx^2$

„ „ „ „ z , or $I_z = \Sigma mx^2 + \Sigma my^2$

Therefore $I_x + I_y + I_z = 2(\Sigma mx^2 + \Sigma my^2 + \Sigma mz^2)$.

Now this is a constant quantity, for

$$x^2 + y^2 + z^2 = r^2$$

Therefore $mx^2 + my^2 + mz^2 = mr^2$ for every particle.

Therefore $\Sigma mx^2 + \Sigma my^2 + \Sigma mz^2 = \Sigma mr^2 = \text{Constant}$.

Therefore $I_x + I_y + I_z = \text{Constant}$,

and this is true whatever the position of the rectangular axes through the fixed point.

PROPOSITION V.—*In any plane through a given point fixed in the body, the axes of greatest and least moment of inertia, for that plane, are at right angles to each other.*

For let us fix, say, the axis of z ; this fixes the value of I_z , and therefore $I_x + I_y = \text{Constant}$.

Hence, when I_x is a maximum I_y is a minimum for the plane xy , and *vice versa*.

PROPOSITION VI.—*If about any axis (Ox) through a fixed point O of a body, the moment of inertia has its greatest value, then*

about some axis (Oz), at right angles to Ox , it will have its least value; and about the remaining rectangular axis (Oy) the moment of inertia will be a maximum for the plane yz , and a minimum for the plane xy .

For, let us suppose that we have experimented on a body and found, for the point O , an axis of maximum moment of inertia, Ox . Then an axis of least moment of inertia must lie somewhere in the plane through O , perpendicular to this, for if in some other plane through O there were an axis of still smaller inertia, then in the plane containing this latter axis, and the axis of x we could find an axis of still greater inertia than Ox , which is contrary to the hypothesis that Ox is a maximum axis.

Next, let us take this minimum axis as the axis of z . The moment of inertia about the remaining axis, that of y , must now be a maximum for the plane yz . For I_x being fixed, $I_x + I_y = \text{constant}$, and therefore I_y is a maximum since I_x is a minimum.

Again, I_x being fixed, $I_x + I_y = \text{constant}$, and therefore I_y is a minimum for the plane xy , since I_x is a maximum.

Definitions.—Such rectangular axes of maximum, minimum, and intermediate moment of inertia are called **principal axes** for the point of the body from which they are drawn, and the moments of inertia about them are called **principal moments of inertia** for the point; and a plane containing two of the principal axes through a point is called a **principal plane** for that point.

When the point of the body through which the rectangular axes are drawn is the Centre of Mass, then the principal axes are called, *par excellence*, **the principal axes** of the body, and the moments of inertia about them **the principal moments of inertia** of the body.

It is evident that for such a body as a rigid rod, the moment of inertia is a maximum about *any* axis through the centre of mass that is at right angles to the rod, and so far as we have gone, there is nothing yet to show that a body may not have several maximum axes in the same plane, with minimum axes between them. We shall see later, however, that this is not the case.

PROPOSITION VII.—*To show that the moment of inertia (I_{OP}) about any axis OP making angles α , β , γ , with the principal axes through any point O, for which the principal moments of inertia are A, B, and C respectively, is*

$$A\cos^2\alpha + B\cos^2\beta + C\cos^2\gamma.$$

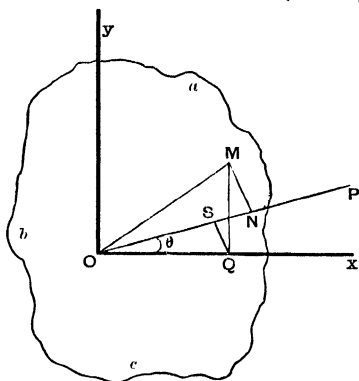

FIG. 24A.

It will conduce to clearness to give the proof first, for the simple case of a plane lamina with respect to axes in its plane.

Let *abc* be the plane lamina, *Ox* and *Oy* any rectangular axes in its plane at the point O, and about these axes let the moments of inertia be (*A'*) and (*B'*) respectively, and let it be required to find the moment of inertia

about the axis OP, making an angle θ with the axis of *x*.

Let M be any particle of the lamina, of mass (*m*), and co-ordinates *x* and *y*. Draw MN perpendicular to OP to meet it in N. Then the moment of inertia of the particle M about OP is $m\overline{MN}^2$. Draw the ordinate MQ, and from Q draw QS

meeting OP at right angles in S. Then

$$\begin{aligned} MN^2 &= OM^2 - ON^2 \\ &= x^2 + y^2 - (OS + SN)^2 \end{aligned}$$

and OS is the projection of OQ on OP, and therefore equal to $x \cos \theta$ and SN is the projection of QM on OP, and therefore equal to $y \sin \theta$

$$\begin{aligned} \therefore \overline{MN}^2 &= x^2 + y^2 - (x \cos \theta + y \sin \theta)^2 \\ &= x^2(1 - \cos^2 \theta) + y^2(1 - \sin^2 \theta) - 2 \sin \theta \cos \theta xy \\ &= x^2 \sin^2 \theta + y^2 \cos^2 \theta - 2 \sin \theta \cos \theta xy \end{aligned}$$

$$\begin{aligned} \therefore I_{OP} = \Sigma m \overline{MN}^2 &= \cos^2 \theta \Sigma m y^2 + \sin^2 \theta \Sigma m x^2 - 2 \sin \theta \cos \theta \Sigma m xy \\ &= A' \cos^2 \theta + B' \sin^2 \theta - 2 \sin \theta \cos \theta \Sigma m xy. \end{aligned}$$

We shall now prove that when the axes chosen coincide with the principal axes so that A' becomes A and B' B , then the factor $\Sigma m xy$, and therefore the last term, cannot have a finite value.

For since the value A of the moment of inertia about O_x is now a maximum, I_{OP} cannot be greater than A , so that $A - I_{OP}$ cannot be a $-ve$ quantity whatever be the position of OP.

i.e. $A - A \cos^2 \theta - B \sin^2 \theta + 2 \sin \theta \cos \theta \Sigma m xy$ cannot be $-ve$,

i.e. $A \sin^2 \theta - B \sin^2 \theta + 2 \sin \theta \cos \theta \Sigma m xy$ cannot be $-ve$,

now, when OP is taken very near to O_x , so that θ is infinitesimally small, then also $\sin \theta$ is infinitesimally small, while $\cos \theta$ is equal to 1, and so that if $\Sigma m xy$ has a finite value, the two first terms of this expression, which contain the *square* of the small quantity $\sin \theta$ may be neglected in comparison with the last term, and according as this last term is $+ve$ or $-ve$, so will the whole expression be $+ve$ or $-ve$.

Now, whether the small angle θ is $+ve$ or $-ve$, $\cos \theta$ is always $+ve$, and $\Sigma(mxy)$ is always constant; neither of these factors then changes signs with θ ; but $\sin \theta$ does change sign with θ ; so that, the last term, and therefore the whole expression is $-ve$ when θ is $-ve$ and very small.

Hence it is impossible that $\Sigma m xy$ can have a finite value.

But Σmxy is constant whatever be the value of θ , and therefore is zero or infinitesimally small even when θ is finite; therefore, finally,

$$I_{OP} = A \cos^2 \theta + B \sin^2 \theta$$

[If we prefer to describe the axis OP as making angles α and β with the rectangular axes of x and y respectively. Then in the above proof we have everywhere $\cos \alpha$ for $\cos \theta$, and $\cos \beta$ for $\sin \theta$, and

$$I_{OP} = A \cos^2 \alpha + B \cos^2 \beta.]$$

The proof of the **general case** for the moment of inertia I_{OP} of a solid body of three dimensions about any axis OP, making angles α , β and γ , with maximum, minimum, and intermediate rectangular axis, Ox , Oy , Oz is exactly analogous to the above, only we have

$$OM^2 = x^2 + y^2 + z^2, \text{ instead of } OM^2 = x^2 + y^2$$

and $ON = x \cos \alpha + y \cos \beta + z \cos \gamma$, instead of $ON = x \cos \alpha + y \cos \beta$,

$$\text{and } \cos^2 \alpha + \cos^2 \beta + \cos^2 \gamma = 1, \text{ instead of } \cos^2 \alpha + \cos^2 \beta = 1,$$

whence it at once follows that instead of the relation

$$I_{OP} = A' \cos^2 \alpha + B' \cos^2 \beta - 2 \cos \alpha \cos \beta \Sigma mxy,$$

we obtain

$$I_{OP} = A' \cos^2 \alpha + B' \cos^2 \beta + C' \cos^2 \gamma - 2 \cos \alpha \cos \beta \Sigma mxy \\ - 2 \cos \beta \cos \gamma \Sigma myz - 2 \cos \gamma \cos \alpha \Sigma mzx.$$

And, as before, when $A' = A$, and $B' = B$, or $C' = C$, each of the last three terms can be shown to be, separately, vanishingly small, and therefore finally

$$I_{OP} = A \cos^2 \alpha + B \cos^2 \beta + C \cos^2 \gamma.$$

Graphical Construction of Inertia-Curves and Surfaces.—*Definition.*—By an ‘inertia-curve’ we mean a plane curve described about a centre, and such that every radius is proportional to the moment of inertia about the axis through the centre of mass whose position it represents. Similarly, a moment of inertia surface is one having the same

It is evident that we can now construct such curves or surfaces when we know the principal moments of inertia of the body.

(I.) *Construction of the inertia curve of any plane lamina for axes in its plane.*

Draw OA and OB at right angles, and of such lengths that they represent the maximum and minimum moment of inertia on a convenient scale, and draw radii between them at intervals of, say, every 10°.

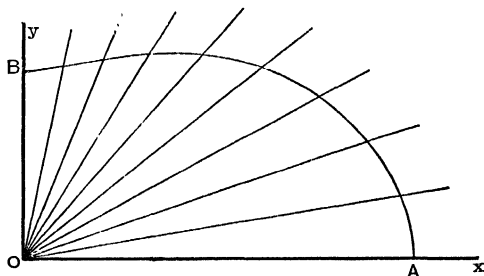

FIG. 25A.

Then mark off on these in succession the corresponding values of the expression

$$\overline{OA} \cos^2 \theta + \overline{OB} \sin^2 \theta,$$

(which may be done graphically by a process that the student will easily discover), and then draw a smooth curve through the points thus arrived at. In this way we obtain the figure of the diagram (Fig. 25A) in which the ratio $\frac{OA}{OB}$ was taken

equal to $\frac{2}{1}$. Complete inertia curves must evidently be symmetrical about both axes, so that the form for one quadrant gives the shape of the whole.

If OA were equal to OB the curve would be a circle, for if maximum and minimum values of the radius are equal, all values are equal.

Figure 26A shows in a single diagram the shape of the

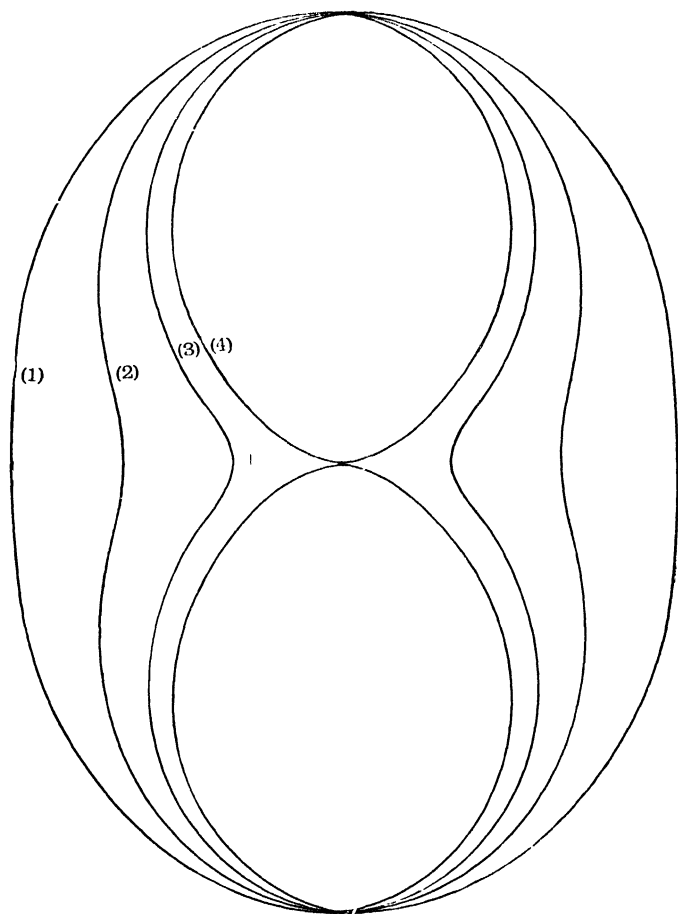

FIG. 26A.

curves when $\frac{OA}{OB}$ has the values $\frac{4}{3}$, $\frac{4}{2}$, $\frac{4}{1}$, and $\frac{4}{0}$ respectively.

(II.) *Construction of Moment of Inertia Surface.*—Let any section through the centre of mass be taken, containing one of the principal axes of the body (say the minimum axis Oz), and let the plane zOC of this section make angles $AOC = \theta$ and $BOC = (90^\circ - \theta)$ or ϕ , with the axes of x and y respec-

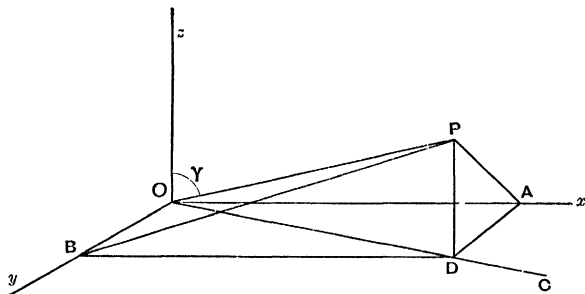

FIG. 27A.

tively. Then, from what has been said, the intersection OC of this plane with that of xy will be a maximum axis for the section ZOC , and the value I_{OC} of the moment of inertia about it will be

$$I_{OC} = A \cos^2 \theta + B \cos^2 \phi.$$

Let the length of OD represent this value. The length of any radius OP of the inertia curve for the section is

$$A \cos^2 \alpha + B \cos^2 \beta + C \cos^2 \gamma.$$

Let the angle COP , or $90^\circ - \gamma$, which OP makes with the plane of xy be called δ . Then $\cos^2 \alpha = \cos^2 AOP$

$$\begin{aligned} &= \frac{\overline{OA}^2}{\overline{OP}^2} = \frac{\overline{OA}^2}{\overline{OD}^2} \times \frac{\overline{OD}^2}{\overline{OP}^2} \\ &= \cos^2 \theta \cos^2 \delta \end{aligned}$$

$$\text{and } \cos^2 \beta = \cos^2 BOP = \frac{\overline{OB}^2}{\overline{OP}^2} = \frac{\overline{OB}^2}{\overline{OD}^2} \times \frac{\overline{OD}^2}{\overline{OP}^2} = \cos^2 \phi \cos^2 \delta$$

$$\begin{aligned} \text{Therefore } I_{OP} &= A\cos^2\theta\cos^2\delta + B\cos^2\phi\cos^2\delta + C\cos^2\gamma \\ &= (A\cos^2\theta + B\cos^2\phi)\cos^2\delta + C\cos^2\gamma \\ &= I_{OC}\cos^2\delta + C\cos^2\gamma. \end{aligned}$$

Therefore the inertia curve for the section zOC may be drawn in precisely the same way as for a plane lamina, and this result holds equally well for all sections containing either a maximum or minimum or intermediate axis.

Inspection of the inertia curves thus traced (Fig. 26A) shows that there is, in general, for any solid (except in the special case when the curve is a circle), only one maximum axis through the centre of mass, and one minimum axis, with a corresponding intermediate axis.

Equipomental Systems.—PROPOSITION VIII.—*Any two rigid bodies of equal mass, and for which the three principal moments of inertia are respectively equal, have equal moments of inertia about all corresponding axes. Such bodies are termed equipomental.*

That such bodies must be equipomental about all corresponding axes through their centres of mass follows directly from the previous proposition; and since any other axis must be parallel to an axis through the centre of mass, it follows from the theorem of parallel axes (Chapter III. p. 37) that in the case of bodies of equal mass, the proposition is true for all axes whatever.

Any body is, for the purposes of Dynamics, completely represented by any equipomental system of equal mass.

Inertia Skeleton.—PROPOSITION IX.—*For any rigid body there can be constructed an equipomental system of three uniform rigid rods bisecting each other at right angles at its centre of mass, and coinciding in direction with its principal axes.*

For let aa' , bb' , cc' (Fig. 27A) be three such rods, coinciding respectively with the principal axes, Ox , Oy , Oz , and let the moment of inertia of aa' about

a perpendicular axis through

O be A'

while that of bb' is B'

and that of cc' is C'

Then, for the system of rods,

$$I_x = B' + C' ; I_y = C' + A' ;$$

$$I_z = A' + B'.$$

If, therefore, the body in question has corresponding

principal moments A , B , C , the system of rods becomes equimomental therewith when

$$B' + C' = A \quad . \quad . \quad . \quad . \quad . \quad (i)$$

$$C' + A' = B \quad . \quad . \quad . \quad . \quad . \quad (ii)$$

$$A' + B' = C \quad . \quad . \quad . \quad . \quad . \quad (iii)$$

These three equations enable us to determine the values of A' , B' , and C' , to be assigned to the rods.

By addition we have,

$$2(A' + B' + C') = A + B + C$$

$$\text{or } A' + B' + C' = \frac{1}{2}(A + B + C)$$

whence subtracting $B' + C' = A$

we have $A' = \frac{1}{2}(B + C - A)$

and similar expressions for B' and C' .

Such a system of rods we may call an *inertia skeleton*. Such a skeleton, composed of rods of the same material and thickness, and differing only in length, presents to the eye an easily recognised picture of the dynamical qualities of the body. The moment of inertia will be a maximum about the

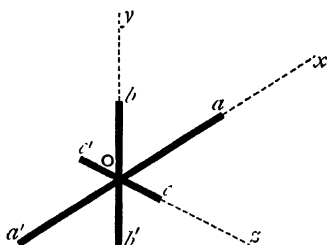

FIG. 27A.

direction of the shortest rod, and a minimum about the direction of the longest.

[It may be mentioned that, for convenience of mathematical treatment of the more difficult problems of dynamics, advantage is taken of the fact that any solid can be shown to be equimomental with a certain homogeneous *ellipsoid* whose principal axes coincide with those of the solid. Also that if we had chosen to trace inertia curves by making the radius everywhere *inversely* proportional to the *radius of gyration*, i.e. to the *square root* of the moment of inertia, then the curve for any plane would have been an ellipse, and the inertia-surface an ellipsoid.]

CHAPTER VI.

SIMPLE HARMONIC MOTION.

The definition of Simple Harmonic Motion may be given as follows :—

Let a particle P travel with uniform speed round the circumference of a fixed circle, and let N be the foot of a perpendicular drawn from P to any fixed line. As P travels round the circle N oscillates to and fro, and is said to have a simple harmonic motion.

It is obvious that N oscillates between fixed limiting positions N_0, N_1 which are the projections on the fixed line of the extremities A and B of the diameter parallel to it, and that at any instant the velocity of N is that part of P's

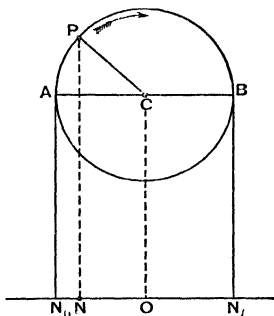

FIG. 32.

velocity which is parallel to the fixed line, or, in other words, the velocity of N is the velocity of P resolved in the direction of the fixed line. Also the acceleration of N is the acceleration of P resolved along the fixed line.

Now the acceleration of P is constant in magnitude, and always directed towards the centre C of the circle, and is equal to $\frac{v^2}{r} = r\omega^2 = (\overline{PC})\omega^2$; consequently the acceleration of

$N = \omega^2 \times$ the resolved part of PC in the direction of the fixed line $= \omega^2 \times (\overline{NO})$, O being the projection of C on the fixed line.

Thus we see that a particle with a simple harmonic motion has an acceleration which is at any instant directed to the middle point about which it oscillates, which is proportional to the displacement from that mean position, and equal to this displacement multiplied by the square of the angular velocity of the point of reference P in the circle.

We shall see, very shortly, that the extremity of a tuning-fork or other sonorous rod, while emitting its musical note of uniform pitch performs precisely such an oscillation. Hence the name 'Simple Harmonic.'

The point O in the figure corresponds to the centre of swing of the extremity of the rod or fork, and the points N_0, N_1 to the limits of its swing.

The time T taken by the point N to pass from one extremity of its path to the other, and back again, is the time taken by P to describe its circular path, viz., $\frac{2\pi}{\omega}$. This is

defined as the '**Period**,' or 'Time of a *complete* oscillation of N. It is evident that if at any instant N have a position

such as that shown in the figure, and be moving (say) to the left, then

after an interval $\frac{2\pi}{\omega}$ it will again be

in the same position and moving in the same direction.

Hence the time of a complete swing is sometimes defined as the interval between two consecutive passages of the point through the same position in the same direction

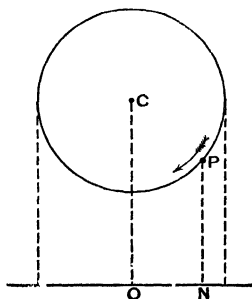

FIG. 33.

The fraction of a period that has elapsed since the point N last passed through its middle position in the positive direction is called the **phase** of the motion.

Since the acceleration of N at any instant

$$= NO \times \omega^2$$

$$= \text{displacement} \times \omega^2$$

$$\therefore \omega^2 = \frac{\text{acceleration at any instant}}{\text{corresponding displacement}}$$

or, abbreviating somewhat,

$$\omega = \sqrt{\frac{\text{acceleration}}{\text{displacement}}}$$

Consequently

$$\text{since } T = \frac{2\pi}{\omega}$$

$$T = 2\pi \times \sqrt{\frac{\text{displacement}}{\text{acceleration}}}$$

The object of pointing out that the time of oscillation has this value will be apparent presently.

It must be carefully noticed that to take a particle and to move it in any arbitrary manner backwards and forwards along a fixed line, is not the same thing as giving it a simple harmonic motion. For this the particle must be so moved as to keep pace exactly with the foot of the perpendicular drawn as described. This it will only do if it is acted on by a force which produces an acceleration always directed towards the middle point of its path and always proportional to its distance from that middle point. We shall now show that a force of the kind requisite to produce a simple harmonic motion occurs very frequently in elastic bodies, and under other circumstances in nature.

CHAPTER VII.

AN ELEMENTARY ACCOUNT OF THE CIRCUMSTANCES AND LAWS OF ELASTIC OSCILLATIONS.

I. For all kinds of distortion, *e.g.*—stretching, compressing, or twisting, the strain or deformation produced by any given force is proportional to the force, so long as the strain or deformation is but small. Up to the limit of deformation for which this is true, the elasticity is called ‘perfect’ or ‘simple’: ‘perfect,’ because if the stress be removed the body is observed immediately and completely to recover itself; and ‘simple,’ because of the simplicity of the relation between the stress and the strain it produces. In brief—

For small deformations the ratio $\frac{\text{stress}}{\text{strain}}$ is constant.

This is known in Physics as **Hooke’s Law**. It was expressed by him in the phrase ‘ut tensio sic vis.’

Illustrations of Hooke’s Law.

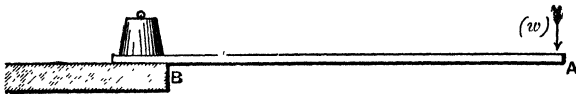

FIG. 34.

(1) If, to the free end A of a long thin horizontal lath, fixed at the other end, a force w be applied which depresses the end through a small distance d , then a force $2w$ will depress it through a distance $2d$, $3w$ through a distance $3d$, and so on.

(2) If the lath be already loaded so as to be already much bent, as in the fig., it is, nevertheless, true if the breaking-strain be not too



FIG. 35.

nearly approached, that the application of a small *additional* force at A will produce a further deflection proportional to the force applied. But it must not be expected that the original force w will now produce the original depression d , for w is now applied to a different object, viz., a much bent lath, whereas it was originally applied to a straight lath.

Thus w will now produce a further depression

			d'
and $2w$	"	"	$2d'$
$3w$	"	"	$3d'$

where d' differs from d .

(3) A horizontal cross-bar is rigidly fixed to the lower end of a long thin vertical wire; a couple is applied to the bar in a horizontal plane, and is found to twist it through an angle θ : then double the couple will twist it through an angle 2θ , and so on.

This holds in the case of long thin wires of steel or brass for twists of the bar through several complete revolutions.

(4) A long spiral spring is stretched by hanging a weight W on to it (Fig. 37).

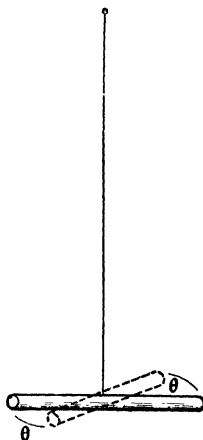

FIG. 36.

If a small extra weight w produces a small extra elongation e ,

Then	"	$2w$	"	"	$2e$,
and	"	$3w$	"	"	$3e$,
					and so on.

Similarly, if a weight w be subtracted from W the shortening will be e ,

and	"	$2w$	"	"	$2e$,
					and so on.

This we might expect, for the spring when stretched by the weight

$W-w$ is so slightly altered from the condition in which it was when stretched by W , that the addition of w must produce the same elongation e as before; therefore the shortening due to the removal of w must be e .

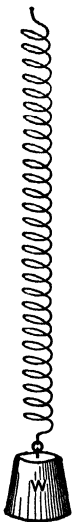

FIG. 37.

From these examples it will be seen that the law enunciated applies to bodies already much distorted as well as to undistorted bodies, but that the value of the constant ratio $\frac{\text{stress}}{\text{corresponding small strain}}$ is not generally the same for the undistorted as for the distorted body.

2. If a mass of matter be attached to an elastic body, as, for instance, is the weight at A in Fig. 35, the cross-bar AB in Fig. 36, or the weight W in Fig. 37, and then slightly displaced and let go, it performs a series of oscillations in coming to rest, under the influence of the force exerted on it by the elastic body. And at any instant the displacement of the mass from its position of rest is the measure of the distortion of the elastic body, and is therefore proportional to the stress between that body and the attached mass.

Hence we see that the small oscillations of such a mass are performed under the influence of a force which is proportional to the displacement from the position of rest.

3. We shall consider, first, linear oscillations, such as those of the mass W in Fig. 37, and shall use for this constant ratio $\frac{\text{force}}{\text{displacement}}$ the symbol R , the force being expressed in absolute units. It will be observed that R measures the resisting power of the body to the kind of deformation in question. For if the displacement be unity, then R =the

corresponding force: thus, R is the *measure of resistance the body offers when subjected to unit deformation*.¹

We shall consider only cases in which the mass of the elastic body itself may be neglected in comparison with the mass M of the attached body whose oscillations we study.

4. If the force be expressed in a suitable unit, the *acceleration* of this mass at any instant is $\frac{\text{force}}{M}$, and is directed towards the position of rest. Since the mass M is a constant quantity, and since the ratio $\frac{\text{force}}{\text{displacement}}$ is constant and equal to R ; therefore, also the ratio $\frac{\text{acceleration}}{\text{displacement}}$ is constant and $= \frac{R}{M}$.

5. Now it is, as we have seen, the characteristic of Simple Harmonic Motion that the acceleration is proportional to the displacement from the mean position.

Consequently we see that when a mass attached to an elastic body, or otherwise influenced by an 'elastic' force, is slightly displaced and then let go, it performs a simple harmonic oscillation of which the corresponding Time of a complete oscillation

$$= 2\pi \sqrt{\frac{\text{displacement}}{\text{acceleration}}}$$

6. Hence (from § 4) we have for the time of the complete linear oscillation of a mass M under an elastic force,

$$T = 2\pi \sqrt{\frac{M}{R}}$$

whatever may be the 'amplitude' of the oscillation, so long as the law of 'simple elasticity' holds.

¹ This is sometimes called the modulus of elasticity of the *body* for the kind of deformation in question, as distinguished from the modulus of elasticity of the *substance*.

7. Applications.—(1) A 10 lb. mass hangs from a long thin light spiral spring. On adding 1 oz. the spring is found to be stretched 1 inch; on adding 2 ozs., 2 inches. Find the time of a complete small oscillation of the 10 lb. weight.

Here we see that the distorting force is proportional to the displacement, and therefore that the oscillations will be of the kind examined. We will express masses in lbs., and therefore forces in poundals. Since a distorting force of $\frac{1}{16}$ pounds ($=\frac{32}{16}=2$ poundals) produces a displacement of $\frac{1}{12}$ ft.

$$\therefore \text{the ratio } \frac{\text{force}}{\text{displacement}} = R = \frac{2}{\frac{1}{12}} = 24.$$

$$\begin{aligned} \therefore T &= 2\pi\sqrt{\frac{M}{R}} = 2\pi\sqrt{\frac{10}{24}} \\ &= 4.05 \text{ sec. (approximately).} \end{aligned}$$

(2) A mass of 20 lbs. rests on a smooth horizontal plane midway between two upright pegs, to which it is attached by light stretched elastic cords. (See fig.)

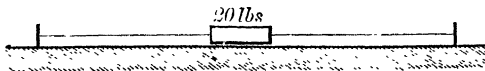

FIG. 38.

It is found that a displacement of $\frac{1}{2}$ an inch towards either peg calls out an elastic resistance of 3 ozs., which is doubled when the displacement is doubled. Find the time of a complete small oscillation of the mass about its position of rest.

$$\text{Here } R = \frac{\text{force}}{\text{displacement}} = \frac{3 \times \frac{1}{16} \times 32 \text{ abs. units.}}{\frac{1}{4}} = 144$$

$$\begin{aligned} \therefore T &= 2\pi\sqrt{\frac{M}{R}} = 2\pi\sqrt{\frac{20}{144}} \text{ sec.} \\ &= 2.34 \text{ sec. (approximately).} \end{aligned}$$

8. The student will now perceive the significance of the limitation of the argument to cases in which the mass of the elastic body itself may be neglected. If, for example, the

spring of Fig. 37 were a very massive one, the mass of the lower portion would, together with W , constitute the total mass acted on by the upper portion; but as the lower portion oscillated its form would alter so that the acceleration of each part of it would not be the same. Thus the considerations become much more complicated.

Hence, also, it is a much simpler matter to calculate, from an observation of the ratio R , the time of oscillation of a heavy

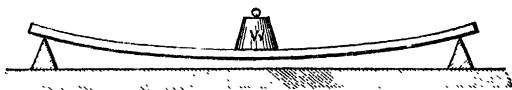

FIG. 39.

mass W placed on a light lath as in the figure, than it is to calculate the time of oscillation of the lath by itself.

9. Extension to Angular Oscillations.—Since any conclusion with respect to the linear motion of matter is true also of its angular motion about a fixed axle, provided we substitute

moment of inertia for mass ;

couple for force ;

angular distance for linear distance ;

it follows that when a body performs *angular* oscillations under the influence of a restoring *couple* whose moment is proportional to the angular displacement, then the time of a complete oscillation is

$$2\pi \sqrt{\frac{I}{R}} \text{ sec.}$$

where I is the moment of inertia with respect to the axis of oscillation and R is the ratio $\frac{\text{couple}}{\text{angular displacement}}$; the couple being measured in absolute units.

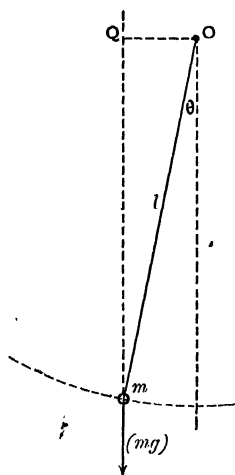

FIG. 40.

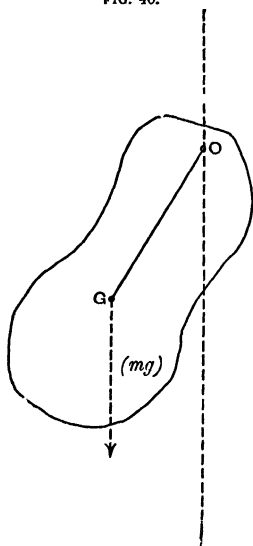

FIG. 41.

Applications.—(1) Take the case of a simple pendulum of length l and mass m . When the displacement is θ , the moment of the restoring force is

$$\begin{aligned} & mg \times OQ \text{ (see fig.)} \\ & = mgl \sin \theta \\ & = mgl \theta \text{ if } \theta \text{ is small.} \end{aligned}$$

$$\therefore R = \frac{\text{moment of couple}}{\text{corresponding displac}^t} = \frac{mgl\theta}{\theta} = mgl.$$

$$\text{Also } I = ml^2$$

$$\begin{aligned} T &= 2\pi \sqrt{\frac{I}{R}} \\ &= 2\pi \sqrt{\frac{ml^2}{mgl}} \\ &= 2\pi \sqrt{\frac{l}{g}} \end{aligned}$$

as also may be shown by a special investigation, such as is given in Garnett's Dynamics, Chap. V.

(2) Next take the case of a body of any shape in which the centre of gravity G is at a distance l from the axis of suspension O .

As before, when the body is displaced through an angle θ , the moment of the restoring couple is $mgl \sin \theta = mgl \theta$ if θ is but small, and

$$R = \frac{\text{moment of couple}}{\text{angular displac}^t} = \frac{mgl \theta}{\theta} = mgl.$$

$$\therefore T = 2\pi \sqrt{\frac{I}{mgl}}$$

10. Equivalent Simple Pendulum.—If K be the radius of gyration of the body about the axis

of oscillation, then $I = mlK^2$, and

$$T = 2\pi\sqrt{\frac{K^2}{gl}}$$

Let L be the length of a simple pendulum which would have the same period of oscillation as this body. The time of a complete oscillation of this simple pendulum is $2\pi\sqrt{\frac{L}{g}}$. For this to be the same as that of the body we must have

$$2\pi\sqrt{\frac{L}{g}} = 2\pi\sqrt{\frac{K^2}{gl}}$$

$$\text{or } L = \frac{K^2}{l}.$$

Examples.—(1) *A thin circular hoop of radius r hung over a peg swings under the action of gravity in its own plane. Find the length of the equivalent simple pendulum.*

Here the radius of gyration K is given by $K^2 = r^2 + l^2$.

And the distance l from centre of gravity to point of suspension is equal to r .

\therefore length of equivalent simple pendulum, which is equal to

$$\frac{K^2}{l},$$

is, in this case, $\frac{r^2 + r^2}{r} = 2r$.

The student should verify this by the experiment of hanging, together with a hoop, a small bullet by a thin string whose length is the diameter of the hoop. The two will oscillate together.

(2) *A horizontal bar magnet, of moment inertia I , makes n complete oscillations per sec. Deduce from this the value of the product MH where M is the magnetic moment of the magnet, and H the strength of the earth's horizontal field.*

Let ns be the magnet. (See Fig. 43.) Imagine it displaced through an angle θ . Then since the magnetic moment is, by definition, the value of the couple exerted on the magnet when placed in a uniform field of unit strength at right angles to the lines of force, it follows

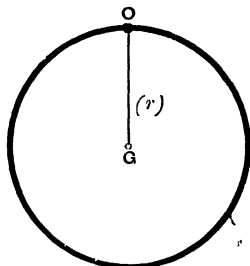

FIG. 42.

that when placed in a field of strength H at an angle θ to the lines of force the restoring couple

$$= MH \sin \theta.$$

$$= MH\theta \text{ when } \theta \text{ is small.}$$

$$\therefore R = \frac{\text{restoring couple}}{\text{angular displac}^t} = \frac{MH\theta}{\theta}$$

$$= MH.$$

$$\text{And } T = 2\pi \sqrt{\frac{I}{R}}$$

$$\therefore T^2 = 4\pi^2 \frac{I}{MH}$$

$$\text{or } MH = \frac{4\pi^2}{T^2} I.$$

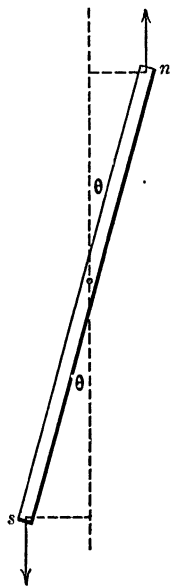

FIG. 43.

N.B.—The student of physics will remember that by using the same magnet placed magnetic E . and W ., to deflect a small needle situated in the line of its axis, we can find the value of the ratio $\frac{M}{H}$. Thus by combining the result of an oscillation-observation of MH with that of a deflection-observation of $\frac{M}{H}$, we obtain the value of H at the place of observation.

(3) A bar magnet oscillates about a central vertical axis under the influence of the earth's horizontal field, and performs 12 complete small oscillations in one minute. Two small masses of lead, each weighing one oz., are placed on it at a distance of 3 inches on either side of the axis, and the rate of oscillation is now reduced to 1 oscillation in 6 seconds. Find the moment of inertia of the magnet.

Let the moment of inertia of the magnet be I oz.-inch² units.

Then the moment of inertia of the magnet with the attached masses is $I + 2 \times 1 \times 3^2 = (I + 18)$ oz.-inch² units.

The time of a complete oscillation of magnet alone is 5 sec.

$$\text{Thus } 2\pi \sqrt{\frac{I}{R}} = 5$$

$$\text{and } 2\pi \sqrt{\frac{I + 18}{R}} = 6.$$

$$\therefore \sqrt{\frac{I+18}{I}} = \frac{6}{5},$$

$$\text{or } \frac{I+18}{I} = \frac{36}{25}.$$

$$\therefore I = 40.909 \text{ oz.-inch}^2 \text{ units.}$$

II. Oscillating Table for finding Moments of Inertia.—A very useful and convenient apparatus for finding the moment of inertia of small objects such as magnets, galvanometric coils, or the models of portions of machinery too large to be directly experimented upon, consists of a flat light circular table 8 or 10 inches in diameter, pivoted on a vertical spindle and attached thereby to a flat spiral spring of many convolutions, after the manner of the balance-wheel of a watch, under the influence of which it performs oscillations that are accurately isochronous. See Fig. 43A.

The first thing to be done is to determine once for all the moment of inertia of the table, which is done by observing, first, the time T_0 of an oscillation with the table unloaded, and then the time T_1 of an oscillation with a load of known moment of inertia I_1 —*e.g.* the disc may be loaded with two small metal cylinders of known weight and dimensions placed at the extremities of a diameter.

Then, since

$$T_0 = 2\pi \sqrt{\frac{I_0}{R}}$$

$$\text{and } T_1 = 2\pi \sqrt{\frac{I_0 + I_1}{R}}$$

$$\therefore I_0 = I_1 \frac{T_0^2}{T_1^2 - T_0^2}$$

I_0 having thus been determined, the value of I for any object laid on the disc, with its centre of gravity directly over the

axis, is found from the corresponding time of oscillation T by the relations

$$T_0 = 2\pi \sqrt{\frac{I_0}{k}}$$

$$\text{and } T = 2\pi \sqrt{\frac{I + I_0}{k}}$$

$$\text{whence } I = I_0 \frac{T^2 - T_0^2}{T_0^2}.$$

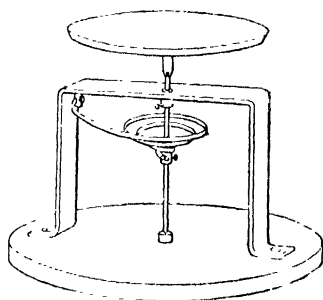

FIG. 43A.

Examples for Solution.

(1) A thin heavy bar, 90 centimetres long, hangs in a horizontal position by a light string attached to its ends, and passed over a peg vertically above the middle of the bar at a distance of 10 centimetres. Find the time of a complete small oscillation in a vertical plane containing the bar, under the action of gravity.

Ans. 1.766 . . . seconds.

(2) A uniform circular disc, of 1 foot radius, weighing 20 lbs., is pivoted on a central horizontal axis. A small weight is attached to the rim, and the disc is observed to oscillate, under the influence of gravity, once in 3 seconds. Find the value of the small weight.

Ans. 1.588 lbs.

(3) A bar magnet 10 centimetres long, and of square section 1 centimetre in the side, weighs 78 grams. When hung horizontally by a fine fibre it is observed to make three complete oscillations in 80 seconds at a place where the earth's horizontal force is .18 dynes. Find the magnetic moment of the magnet.

Ans. 202.48 . . . dyne-centimetre units.

(4) A solid cylinder of 2 centimetre radius, weighing 200 grams, is rigidly attached with its axis vertical to the lower end of a fine wire. If, under the influence of torsion, the cylinder make 0.5 complete oscillations per second, find the couple required to twist it through four complete turns.

Ans. $3200 \times \pi^3$ dyne-centimetre units.

(5) A pendulum consists of a heavy thin bar 4 ft. long, pivoted about an axle through the upper end. Find (1) the time of swing ; (2) the length of the equivalent simple pendulum.

Ans. (1) 1.81 seconds approximately ; (2) 2.6 feet.

(6) Out of a uniform rectangular sheet of card, 24 inches \times 16 inches, is cut a central circle 8 inches in diameter. The remainder is then supported on a horizontal knife-edge at the nearest point of the circle to a shortest side. Find the time of a complete small oscillation under the influence of gravity (a) in the plane of the card ; (b) in a plane perpendicular thereto.

Ans. (a) 1.555 seconds ; (b) 1.322 seconds.

(7) A long light spiral spring is elongated 1 inch by a force of 2 pounds, 2 inches by a force of 4 pounds. Find how many complete small oscillations it will make per minute with a 3 lb. weight attached.

Ans. 152.7

CHAPTER VIII.

CONSERVATION OF ANGULAR MOMENTUM.

Analogue in Rotation to Newton's Third Law of Motion.—Newton's Third Law of Motion is the statement that to every action there is an equal and opposite reaction.

This law is otherwise expressed in the Principle of the Conservation of Momentum, which is the statement that when two portions of matter act upon each other, whatever amount of momentum is generated in any direction in the one, an equal amount is generated in the opposite direction in the other. So that the total amount of momentum in any direction is unaltered by the action.

In the study of rotational motion we deal not with forces but with torques, not with linear momenta but with angular momenta, and the analogous statement to Newton's Third Law is that 'no torque, with respect to any axis, can be exerted on any portion of matter without the exertion on some other portion of matter of an equal and opposite torque about the same axis.'

To deduce this as an extension of Newton's Third Law, it is sufficient to point out that the reaction to any force being not only equal and opposite, but also in *the same straight line* as the force, must have an equal and opposite moment about any axis.

The corresponding principle of the conservation of angular momentum is that by no action of one portion of matter

on another can the total amount of angular momentum, about any fixed axis in space, be altered.

Application of the Principle in cases of Motion round a fixed Axle.—We have seen (p. 21) that the ‘angular or rotational momentum’ of a rigid body rotating about a fixed axle is the name given, by analogy with linear momentum (mv), to the product $I\omega$, and that just as a force may be measured by the momentum it generates in a given time, so the moment of a force may be measured by the angular momentum it generates in a given time.

1st Example of the Principle.—Suppose a rigid body A, say a disc whose moment of inertia is I_1 , to be rotating with angular velocity ω_1 about a fixed axle; and that on the same shaft is a second disc B of moment of inertia I_2 , and which we will at first suppose to be at rest. Now, imagine the disc B to be slid along the shaft till some projecting point of it begins to rub against A. This will set up a force of friction between the two, the moment of which will at every instant be the

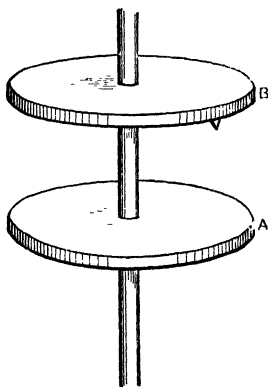

FIG. 44.

same for each, consequently as much angular momentum as is destroyed in A will be imparted to B, so that the total quantity of angular momentum will remain unaltered. Ultimately the two will rotate together with the same angular velocity Ω which is given by the equation

$$(I_1 + I_2)\Omega = I_1\omega_1,$$

$$\text{or } \Omega = \frac{I_1\omega_1}{I_1 + I_2}.$$

If the second disc had initially an angular velocity ω_2 , then the equation of conservation of angular momentum gives us

$$(I_1 + I_2)\Omega = I_1\omega_1 + I_2\omega_2,$$

$$\text{or } \Omega = \frac{I_1\omega_1 + I_2\omega_2}{I_1 + I_2},$$

which, it will be observed, corresponds exactly to the equation of conservation of linear momentum in the direct impact of inelastic bodies, viz.:—

$$(m_1 + m_2)V = m_1v_1 + m_2v_2.$$

2nd Example.—A horizontal disc whose moment of

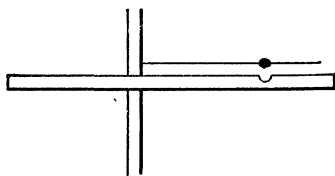

FIG. 45.

inertia is I_1 , rotates about a fixed vertical axis with angular velocity ω_1 . Imagine a particle of any mass to be detached from the rest, and connected with the axis by

an independent rigid bar whose mass may be neglected. At first let the particle be rotating with the rest of the system with the same angular velocity ω_1 . Now, let a horizontal pressure, always at right angles to the rod and parallel to the disc, be applied between them so that the rotation of the particle is checked, and that of the remainder of the system accelerated (*e.g.* by a man standing on the disc and pushing against the radius rod as one would push against the arm of a lock-gate on a canal), until finally the particle is brought to rest. By what has just been said, as much angular momentum as is destroyed in the particle will be communicated to the remainder of the disc, so that the total angular momentum will remain unaltered. We may now imagine the stationary non-rotating particle transferred to the axis, and there again attached to the remainder of the system, without affecting

the motion of the latter. If I_2 is now the reduced moment of inertia of the system, and ω_2 its angular velocity, we have, by what has been said,

$$I_2\omega_2 = I_1\omega_1$$

$$\text{or } \omega_2 = \omega_1 \frac{I_1}{I_2}.$$

Or, we may imagine the particle, after having been brought to rest, placed at some other position on its radius, and allowed to come into frictional contact with the disc again, till the two rotate together again as one rigid body. If I_3 be now the moment of inertia of the system, we shall have

$$I_3\omega_3 = I_2\omega_2 = I_1\omega_1,$$

$$\text{or } \omega_3 = \omega_1 \times \frac{I_1}{I_3}.$$

3rd Example.—Suppose that, by the application of a force always directed towards the axis, we cause a portion of a rotating body to slide along a radius so as to alter its distance from the axis. By doing so we evidently alter the moment of inertia of the system, but the angular momentum about the axis will remain constant.

For example, let a disc rotating on a hollow shaft be provided with radial grooves along which two equal masses can be drawn towards the axis by means of strings passing down the interior of the shaft. It is clear that each of the moveable masses as it is drawn along the groove is brought into successive contact with parts of the disc moving more slowly than itself, and must thus impart angular momentum to them, losing as much as it imparts.

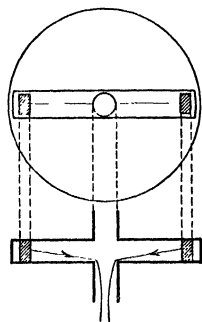

FIG. 46.

4th Example.—A mass M rotates on a smooth horizontal

plane, being fastened to a string which passes through a small hole in the plane, and which is held by the hand. On slackening the string the mass recedes from the axis and revolves more slowly; on tightening the string the mass approaches the axis and revolves faster. [See Appendix, p. 164.]

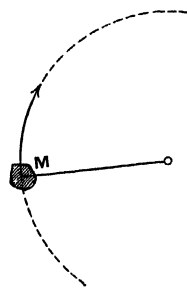

FIG. 47.

Here, again, the angular momentum $I\omega$ will remain constant, there being no external force with a moment about the axis to increase its amount. But it is not so apparent in this case how the increase of angular velocity that accompanies the diminution of moment of inertia has been brought about.

For simplicity, consider instead of a finite mass M a particle of mass m at distance r from the axis when rotating with angular velocity ω . The moment of inertia I of the particle is then mr^2 and the angular momentum $= I\omega$

$$= mr^2\omega$$

but $r\omega = v$ the tangential speed;

\therefore the angular momentum $= mrv$,

thus for the angular momentum to remain constant v must increase exactly in proportion as r diminishes, and *vice versa*.

In the case in question the necessary increase in v is effected by the resolved part of the central pull in the direction of the motion of the particle. For the instant this pull exceeds the value $\left(\frac{mv^2}{r}\right)$ of the centripetal force necessary to keep the particle moving in its circular path, the particle begins to be drawn out of that path, and no longer moves at right angles to the force, but partly in its direction, and with increasing velocity, along a spiral path.

This increase in velocity involves an increase in the kinetic energy of the particle equivalent to the work done by the force.

Consideration of the Kinetic Energy.—It should be observed, in general, that if by means of forces having no moment about the axis we alter the moment of inertia of a system, then the kinetic energy of rotation about that axis is altered in inverse proportion. For, let the initial moment of inertia I_1 become I_2 under the action of such forces, then the new angular velocity by the principle of the conservation of angular momentum

$$\text{is } \omega_2 = \omega_1 \times \frac{I_1}{I_2}$$

and the new value of the rotational energy is $\frac{1}{2}I_2\omega_2^2$

$$\begin{aligned} &= \frac{1}{2}I_2\omega_1^2 \times \frac{I_1^2}{I_2} \\ &= \frac{1}{2}I_1\omega_1^2 \times \frac{I_1}{I_2} \\ &= (\text{original energy}) \times \frac{I_1}{I_2}. \end{aligned}$$

The student will see that in Example 2, p. 84, the stoppage of the particle with its radius rod in the way described involves the communication of additional rotational energy to the disc, and that, in Example 3, the pulling in of the cord attached to the sliding masses communicated energy to the system, though not angular momentum.

Other Exemplifications of the Principle of the Conservation of Angular Momentum.—(I) A juggler standing on a spinning disc (like a music-stool) can cause his rate of rotation to decrease or increase by simply extending or drawing in his arms. The same thing can be done by a skater spinning round a vertical axis with his feet close together on well-rounded skates.

(2) When water is let out of a basin by a hole in the bottom, as the outward parts approach the centre, any rotation, however slight and imperceptible it may have been at first, generally becomes very rapid and obvious.¹

(3) Thus, also, we see that any rotating mass of hot matter which shrinks as it cools, and so brings its particles nearer to the axis of rotation, will increase its rate of rotation as it cools.

The sun and the earth itself, and the other planets, are probably all of them cooling and shrinking, and their respective rates of rotation, therefore, on this account increasing.

If the sun has been condensed from a very extended nebulous mass, as has been supposed, a very slow rate of revolution, in its original form, would suffice to account for the present comparatively rapid rotation of the sun (one revolution in about 25 days).

Graphical representation of Angular Momentum.

—The angular momentum about any line of any moving body or system may be completely represented by marking off on that line a length proportional to the angular momentum in question.

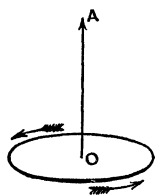

FIG. 48.

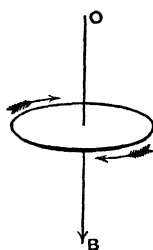

FIG. 49.

tion of the corresponding rotation is conveniently indicated by the convention that the length shall be named in the direction in which a right-handed screw would advance through its nut if turning with the same rotation. Thus OA and OB

in Figs. 48 and 49 would represent angular momenta, as

¹ It can be shown that other causes besides that mentioned may also produce the effect referred to.

shown by the arrows. Since a couple has no moment about any axis in its plane and has the same moment about every axis perpendicular to its plane, and is measured by the angular momentum it generates in unit time about any such axis, it follows that a line drawn parallel to the axis of a couple and of a length proportional to its moment, equally represents both the couple and the angular momentum it would generate in unit time, and hence the angular momenta generated by couples can be combined and resolved exactly as we combine or resolve couples. Thus if a body whose angular momentum has been generated by the action of a couple and is represented by OA , be acted on for a time by a couple about a perpendicular axis, this cannot alter the angular momentum about OA , but will add an angular momentum which we may represent by OB perpendicular to OA . Then the total angular momentum of the body must be represented by the diagonal OC of the parallelogram AB (Fig. 50). And in general the amount of angular momentum existing about any line through O is represented by the projection on that line of the line representing the total angular momentum in question.

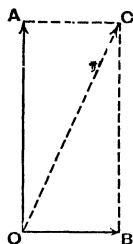

FIG. 50.

Moment of Momentum.—The phrase ‘angular or rotational momentum’ is convenient only so long as we are dealing with a single particle or with a system of particles rigidly connected to the axis, so that each has the same angular velocity; when, on the other hand, we have to consider the motions of a system of disconnected parts, the principle of conservation of angular momentum is more con-

veniently enunciated as the ‘**conservation of moment of momentum.**’

By the moment of momentum, at any instant, of a particle about any axis is meant the product (mvp) of the resolved part (mv) of the momentum in a plane perpendicular to the axis, and the distance (p) of its direction from the axis; or the moment of momentum of a particle may be defined and thought of as that part of the momentum which alone is concerned in giving rotation about the axis, multiplied by the distance of the particle from the axis. Since the action of one particle on another always involves the simultaneous generation of equal and opposite momenta along the line joining them (see Note on Chapter II.), it follows that the moments about any axis of the momenta generated by such interaction are also equal and opposite. Hence in any system of particles unacted on by matter outside there is conservation of moment of momentum, or, in algebraical language,

$$\Sigma(mvp) = \text{constant.}$$

The moment of momentum of a particle as thus defined is easily seen to be the same thing as its angular momentum $i\omega$.

For, as we have seen—see Appendix (1)— $\omega = \frac{pv}{r^2}$ and i (by definition) $= mr^2$

$$\therefore i\omega = mvp.$$

General Conclusion.—The student will now be prepared to accept the conclusion that if, under any circumstances, we observe that the forces acting on any system cause an alteration in the angular momentum of that system about any given fixed line, then we shall find that an equal and opposite alteration is simultaneously produced in the angular momentum about the same axis, of matter external to the system.

Caution.—At the same time he is reminded that it is only in the case of a rigid body rotating about a fixed axle that we have learned that the angular momentum about that axle is measured by $I\omega$. He must not conclude either that there is no angular momentum about an axis perpendicular to the actual axis of rotation; or that $I\omega$ will express the angular momentum about an axis when ω is only the component rotational velocity about that axis.

Thus if a body, consisting of two small equal masses mm , united by a massless rigid rod be rotating, say right-handedly, about a fixed axis oy , bisecting the rod and making an acute angle with it, then it is evident that, at the instant represented in the diagram, though the rotation is about oy and has no component about ox , yet, on account of the velocity of each mass perpendicular to the plane of the paper there is actually more angular momentum (left-handed) about ox than there is (right-handed) about oy .

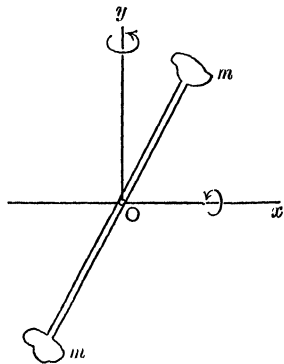

FIG. 51.

This point will be fully discussed in Chapter XII.

Ballistic Pendulum.—In Robins's ballistic pendulum, used for determining the velocity of a bullet, we have an interesting practical application of the principle of conservation of moment of momentum. The pendulum consists of a massive block of wood rigidly attached to a fixed horizontal axle above its centre of gravity about which it can turn

freely, the whole being symmetrical with respect to a vertical plane through the centre of mass perpendicular to the axle. The bullet is fired horizontally into the wood in this plane of symmetry perpendicular to the axle, and remains embedded in the mass, penetration ceasing before the pendulum has moved appreciably. The amplitude of swing imparted to the pendulum is observed, and from this the velocity of the bullet before impact is easily deduced. Let I be the moment of inertia of the pendulum alone about the axle, M its mass, d the distance of its centre of gravity from the axis, and let θ be the angle through which the pendulum swings to one side.

Then, neglecting the relatively small moment of inertia of the bullet itself, the angular velocity ω at its lowest point is found by writing

$$\left. \begin{array}{l} \text{Kinetic energy of} \\ \text{pendulum} \\ \text{at lowest point,} \end{array} \right\} = \left\{ \begin{array}{l} \text{work subsequently done} \\ \text{against gravity in rising} \\ \text{through angle } \theta, \end{array} \right.$$

$$\frac{1}{2} I \omega^2 = Mgd(1 - \cos\theta),$$

an equation which gives us ω .

Now, let v be the velocity of the bullet before impact that we require to find, m its mass, and l the shortest distance from the axis to the line of fire. Then writing

$$\left. \begin{array}{l} \text{moment of momentum about} \\ \text{axis before impact,} \end{array} \right\} = \left\{ \begin{array}{l} \text{angular momentum about} \\ \text{axis after impact,} \end{array} \right.$$

$$\text{we have} \quad mvl = I\omega,$$

which gives us v .

The student should observe that we apply the principle of conservation of *energy* only to the frictionless swinging of the pendulum, as a convenient way of deducing its velocity at its lowest point. Of the original energy of the bullet the greater part is dissipated as heat inside the wood.

In order to avoid a damaging shock to the axle, the bullet would, in practice, be fired along a line passing through the centre of percussion, which, as we shall see (p. 124), lies at a distance from the axis equal to the length of the equivalent simple pendulum.

Examples.

(1) A horizontal disc, 8 inches in diameter, weighing 8 lbs., spins without appreciable friction at a rate of ten turns per second about a thin vertical axle, over which is dropped a sphere of the same weight and 5 inches in diameter. After a few moments of slipping the two rotate together. Find the common angular velocity of the two, and also the amount of heat generated in the rubbing together of the two (taking 772 foot-pounds of work as equivalent to one unit of heat).

Ans. (i) 7·619 turns per sec.

„ (ii) ·008456 units of heat.

(2) A uniform sphere, 8 inches in radius, rotates without friction about a vertical axis. A small piece of putty weighing 2 oz. is projected directly on to its surface in latitude 30° on the sphere and there sticks, and the rate of spin is observed to be thereby reduced by $\frac{1}{3}$. Find the moment of inertia of the sphere, and thence its specific gravity.

Ans. (i) $7\frac{1}{3}$ oz.-foot² units.

„ (ii) ·0332.

(3) Prove that the radius vector of a particle describing an orbit under the influence of a central force sweeps out equal areas in equal times.

(4) A boy leaps radially from a rapidly revolving round-about on to a neighbouring one at rest, to which he clings. Find the effect on the second, supposing it to be unimpeded by friction, and that the boy reaches it along a radius.

(5) Find the velocity of a bullet fired into a ballistic pendulum from the following data:—

The moment of inertia of the pendulum is 200 lb.-foot² units, and it weighs 20 lbs. The distance from the axis of its centre of gravity is 3 feet, and of the horizontal line of fire is $\frac{3}{4}$ feet; the bullet penetrates as far as the plane containing the axis and centre of mass and weighs 2 oz. The cosine of the observed swing is $\frac{4}{5}$.

Ans. 950·39 feet per sec.

(taking $g=32\cdot2$.)

CHAPTER IX.

ON THE KINEMATICAL AND DYNAMICAL PROPERTIES OF THE CENTRE OF MASS.

Evidence of the existence for a Rigid Body of a point possessing peculiar dynamical relations.—

Suppose a single external force to be applied to a rigid body previously at rest and perfectly free to move in any manner. The student will be prepared to admit that, in accordance with Newton's Second Law of Motion, the body will experience an acceleration proportional directly to the force and inversely to its mass and that it will begin to advance in the direction of the

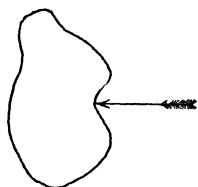

FIG. 52.

applied force. But Newton's Law does not tell us explicitly whether the body will behave differently according to the position of the point at which we apply the force, always assuming it to be in the same direction.

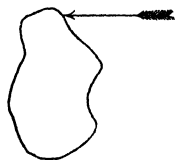

FIG. 53.

Now, common experience teaches us that there is a difference. If, for example, the body be of uniform material, and we apply the force near to one edge, as in the second figure, the body begins to turn, while if we apply the force at the opposite edge, the body will turn in the opposite direction. It is always possible, however, to find a point through which, if the force be ap-

plied, the body will advance without turning. The student should observe that if, when the force was applied at one edge of the body, as in Fig. 2, the body advanced without turning, precisely as we may suppose it to have done in Fig. 1, this would not involve any deviation from Newton's Law applied to the body *as a whole*, for the force would still be producing the same mass-acceleration in its own direction.

It is evidently important to know under what circumstances a body will turn, and under what circumstances it will not.

The physical nature of the problem will become clearer in the light of a few simple experiments.

Experiment 1.—Let any convenient rigid body, such as a walking-stick, a hammer, or say a straight rod conveniently weighted at one end, be held vertically by one hand and then allowed to fall, and while falling let the observer strike it a smart horizontal blow, and observe whether this causes it to turn, and which way round; it is easy, after a few trials, to find a point at which, if the rod be struck, it will not turn. If struck at any other point it does turn. The experiment is a partial realisation of that just alluded to.

Experiment 2.—It is instructive to make the experiment in another way. Let a smooth stone of any shape, resting loosely on smooth hard ice, be poked with a stick. It will be found easy to poke the stone either so that it shall turn, or so that it shall not turn, and if the direction of the thrusts which move the stone without rotation be noticed, it will be found that the vertical planes containing these directions intersect in a common line. If, now, the stone be turned on its side and the experiments be repeated, a second such line can be found intersecting the first. The intersection gives a point through which it will be found that any force must pass which will cause motion without turning.

Experiment 3.—With a light object, such as a flat piece of paper or card of any shape, the experiment may be made by laying it, with a very fine thread attached, on the surface of a horizontal mirror dusted over with lycopodium powder to diminish friction, and then tugging

at the thread; the image of the thread in the mirror aids in the alignment. The thread is then attached at a different place, and a second line on the paper is obtained.

If a body, in which the position of the point having these peculiar properties has been determined by any of the methods described, be examined to find the Centre of Gravity, it will be found that within the limits of experimental error the two points coincide. This result may be confirmed by the two following experiments.

Experiment 4.—Let a rigid body of any shape whatever be allowed to fall freely from rest. It will be observed that, in whatever position the body may have been held, it falls without turning (so long at any rate as the disturbing effect of air friction can be neglected). In this case we know that the body is, in every position, acted on by a system of forces (the weights of the respective particles) whose resultant passes through the centre of gravity.

Experiment 5.—When a body hangs at rest by a string, the direction of the string passes through the centre of gravity. If the string be pulled either gradually or with a sudden jerk, the body moves upward with a corresponding acceleration, but again without turning. This is a very accurate proof of the coincidence of the two points.

We now pass to another remarkable dynamical property, which may be enunciated as follows:—

‘If a couple be applied to a non-rotating rigid body that is perfectly free to move in any manner, then the body will begin to rotate about an axis passing through a point not distinguishable from the centre of gravity.’

This very important property is one which the student should take every opportunity of bringing home to himself.

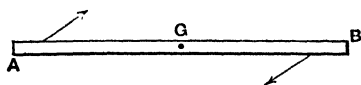

FIG. 54.

If a uniform bar, AB, free to move in any manner, be acted on by a couple whose forces are applied

as indicated, each at the same distance from the centre of mass G , then it is easy to believe that the bar will begin to turn about G . But if one force be applied at A and the other

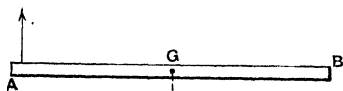

FIG. 55.

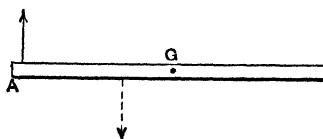

FIG. 56.

at G itself, as in Fig. 55, or between A and G , as in Fig. 56, then it is by no means so obvious that G will be the turning point. The matter may be brought to the test of experiment in the manner indicated in the following figure.

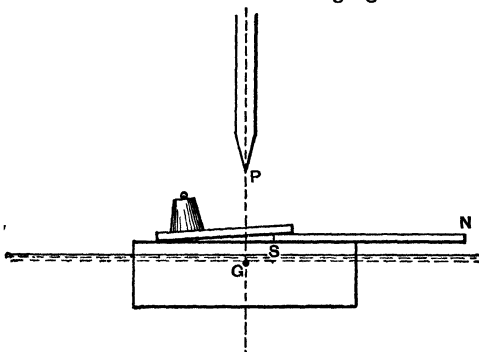

FIG. 57.

Experiment 6.—A Magnet NS lies horizontally on a square-cut block of wood, being suitably counterpoised by weights of brass or lead, so that the wood can float as shown in a large vessel of still water. The whole is turned so that the magnet lies magnetic east and west, and then released, when it will be observed that the centre of gravity G remains¹ vertically under a fixed point P as the whole

¹ The centre of gravity must, for hydrostatic reasons, be situated in the same vertical line as the centre of figure of the submerged part of the block.

turns about it. It is assumed here that the magnet is affected by a horizontal couple due to the earth's action.

We now proceed to show experimentally that when a rigid body at rest and free to move in any manner is acted on by forces having a resultant which does not pass through the

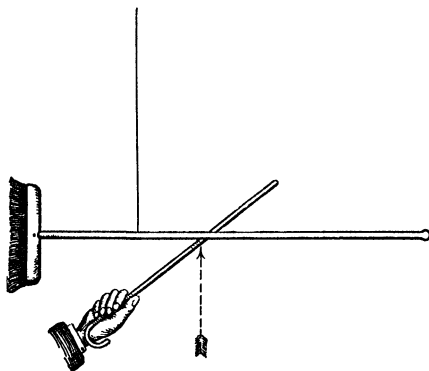

FIG. 58.

centre of Gravity, then the body begins to rotate with angular acceleration about the centre of Gravity, while at the same time the centre of gravity advances in the direction of the resultant force.

Experiment 7.—Let any rigid body hanging freely at rest by a string be struck a smart

blow vertically upwards. It will be observed that the centre of gravity rises *vertically*, while at the same time the body turns about it, unless the direction of the blow passes exactly through the centre of gravity.

[It will be found convenient in making the experiment for the observer to stand so that the string is seen projected along the vertical edge of some door or window frame. The path of the Centre of Gravity will then be observed not to deviate to either side of this line of projection. The blow should be strong enough to lift the centre of mass considerably, and it is well to select an object with considerable moment of inertia about the Centre of Gravity, so that though the blow is eccentric the body is not thereby caused to spin round so quickly as to strike the string and thus spoil the experiment.]

We have now quoted direct experimental evidence of the existence in the case of rigid bodies of a point having peculiar dynamical relations to the body, and have seen that we are unable experimentally to distinguish the position of this point from that of the centre of gravity. But this is no proof that the two points actually coincide. Our experiments have not been such as to enable us to decide that the points are not in every case separated by $\frac{1}{10000}$ inch, or even by $\frac{1}{100}$ inch.

We shall now proceed to prove that the point which has the dynamical relations referred to is that known as the **Centre of Mass**, and defined by the following relation. Let m_1, m_2, m_3, \dots be the masses of the constituent particles of any body or system of particles; and let x_1, x_2, x_3, \dots be their respective distances from any plane, then the distance \bar{x} of the centre of mass from that plane is given by the

$$\text{relation } \bar{x} = \frac{m_1x_1 + m_2x_2 + \dots}{m_1 + m_2 + m_3 + \dots}$$

$$\text{or } \bar{x} = \frac{\Sigma(mx)}{\Sigma m}.$$

That the centre of mass whose position is thus defined coincides experimentally with the centre of gravity, follows, as was pointed out in the note on p. 38, from the experimental fact, for which no explanation has yet been discovered, that the mass or inertia of different bodies is proportional to their weight, *i.e.* to the force with which the earth pulls them.

Our method of procedure will be, first formally to enunciate and prove certain very useful but purely kinematical properties of the Centre of Mass, and then to give the theoretical proof that it possesses dynamical properties, of which we have selected special examples for direct experimental demonstration.

By the student who has followed the above account of the experimental phenomena, the physical meaning of these propositions will be easily perceived and their practical importance realised, even though the analytical proofs now to be given may be found a little difficult to follow or recollect.

PROPOSITION I.—(Kinematical.) On the displacement of the centre of mass.

If the particles of a system are displaced from their initial positions in any directions, then the displacement \bar{d} experienced by the centre of mass of the system in any one chosen direction is connected with the resolved displacements d_1, d_2, d_3, \dots of the respective particles in the same direction by the relation

$$\bar{d} = \frac{m_1 d_1 + m_2 d_2 + \dots + m_n d_n}{m_1 + m_2 + \dots + m_n}$$

$$\text{or } \bar{d} = \frac{\Sigma(md)}{\Sigma m}.$$

Proof.—For, let any plane of reference be chosen, perpendicular to the direction of resolution, and let \bar{x} be the distance of the centre of mass from this plane before the displacements, \bar{x}' its distance after the displacements,

$$\text{Then } \bar{x} = \frac{\Sigma(mx)}{\Sigma m} \text{ and } \bar{x}' = \frac{\Sigma m(x+d)}{\Sigma m}$$

$$= \frac{\Sigma(mx)}{\Sigma m} + \frac{\Sigma(md)}{\Sigma m}$$

$$\therefore \bar{x}' - \bar{x} = \bar{d} = \frac{\Sigma(md)}{\Sigma m}. \quad \text{Q.E.D.}$$

If $\Sigma(md) = 0$, then $\bar{d} = 0$, i.e. if, on the whole, there is no mass-displacement in any given direction, then there is no displacement of the centre of mass in that direction.

Definitions.—If a rigid body turns while its centre of mass remains stationary, we call the motion one of **pure rotation**.

When, on the other hand, the centre of mass moves, then we say that there is a motion of **translation**.

PROPOSITION II.—(Kinematical.) On the velocity of the centre of mass of a system. *If v_1, v_2, v_3, \dots be the respective velocities in any given direction at any instant of the particles of masses $m_1, m_2, m_3, \text{etc.}$, of any system, then the velocity \bar{v} of their centre of mass in the same direction is given by the relation*

$$\bar{v} = \frac{\Sigma(mv)}{\Sigma m}.$$

This follows at once from the fact that the velocities are measured by, and are therefore numerically equal to, the displacements they would produce in unit time.

PROPOSITION III.—(Kinematical.) On the acceleration of the centre of mass. *If a_1, a_2, \dots be the accelerations in any given direction, and at the same instant of the respective particles of masses m_1, m_2, \dots of a system, then the acceleration \bar{a} of their centre of mass in the same direction at that instant, is given by the relation*

$$\bar{a} = \frac{\Sigma(ma)}{\Sigma m}.$$

This follows from Proposition II., for the accelerations are measured by, and are therefore numerically equal to, the velocities they would generate in unit time.

Summary.—These three propositions may be conveniently summed up in the following enunciation.

The sum of the resolutes in any direction of the $\left\{ \begin{array}{l} \text{mass-displacements} \\ \text{momenta} \\ \text{mass-accelerations} \end{array} \right\}$
of the particles of any system is equal to the total mass of the
system multiplied by the $\left\{ \begin{array}{l} \text{displacement} \\ \text{velocity} \\ \text{acceleration} \end{array} \right\}$, in the same direction,
of the centre of mass.

Corresponding to these three Propositions are three others referring to the sum of the *moments* about any axis of the $\left\{ \begin{array}{l} \text{mass-displacements} \\ \text{momenta} \\ \text{mass-accelerations} \end{array} \right\}$ of the particles of a system, and which may be enunciated as follows:—

‘The algebraic sum of the moments about any given fixed axis of the $\left\{ \begin{array}{l} \text{mass-displacements} \\ \text{momenta} \\ \text{mass-accelerations} \end{array} \right\}$ of the particles of any system is equal to the sum of the moments of the same quantities about a parallel axis through the centre of mass, plus the moment about the given axis of the $\left\{ \begin{array}{l} \text{displacement} \\ \text{velocity} \\ \text{acceleration} \end{array} \right\}$ of the centre of mass, multiplied by the mass of the whole system.

Since the moment of the *mass-displacement* of a particle has no special physical significance, we will begin at the second link of the chain and give the proof for the angular momenta.

PROPOSITION IV.—(Kinematical.) *The angular momentum of any system of particles about any fixed axis, is equal to the angular momentum about a parallel axis through the centre of mass + the angular momentum which the system would have about the given axis if all collected at the centre of mass and moving with it.*

Proof.—Let the plane of the diagram pass through a particle P and be perpendicular to the given fixed axis O and let G be the projection on this plane of the centre of mass. Join OG. Let PQ represent the resolute (v) of the velocity of P in

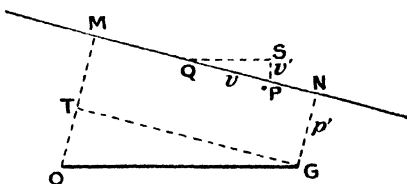

FIG. 59.

the plane of the diagram; PS the resolute v' of this velocity perpendicular to OG. Draw OM ($=p$) perpendicular to PQM; GT parallel to PQ and GN ($=p'$) parallel to GM.

Then the angular momentum of P about O $= pmv = mv \times$

$$OM = mv(TM + OT) = mvp' + mvOG \frac{PS}{PQ} = p'mv + mv'OG.$$

Therefore, summing for all the particles of the system,

Total angular momentum about O $= \Sigma(pmv) = \Sigma(p'mv) + \Sigma(OGmv') = \Sigma(p'mv) + OG\Sigma(mv') = \Sigma(p'mv) + OG\bar{v}\Sigma m$, where \bar{v} is the velocity of the centre of mass perpendicular to OG. This proves the proposition.

Corollary.—If the centre of mass is at rest $\bar{v}' = 0$ and $\Sigma pmv = \Sigma p'mv$, thus the angular momentum of a spinning body whose centre of mass is at rest is the same about all parallel

this. He will easily associate it with the fact that the angular momentum measures the impulse of the couple that has produced it, and that the moment of a couple is the same about all parallel axes.

PROPOSITION V.—(Kinematical.) In exactly the same way, substituting accelerations for velocities, we can prove that

$$\Sigma(pma) = \Sigma p'ma + OG\dot{a}'\Sigma m.$$

PROPOSITION VI.—(Dynamical.) On the motion of the centre of mass of a body under the action of external forces. We shall now show that

The acceleration in any given direction of the centre of mass of a material system

$$= \frac{\text{algebraic sum of the resolutes in that direction of the external forces}}{\text{mass of the whole system}}$$

For, by Newton's Second Law of Motion (see note on Chapter II),

$$\left(\begin{array}{l} \text{the algebraic sum of the ex-} \\ \text{ternal forces,} \end{array} \right) = \left(\begin{array}{l} \text{the algebraic sum of the mass-} \\ \text{accelerations,} \end{array} \right)$$

$$\Sigma E = \Sigma(ma);$$

$$\text{but by III. } \Sigma(ma) = \bar{a}\Sigma m;$$

$$\therefore \Sigma E = \bar{a}\Sigma m,$$

$$\text{or } \bar{a} = \frac{\Sigma E}{\Sigma m},$$

which is what we had to prove.

This result is quite independent of the manner in which the external forces are applied, and shows that when the forces are constant and have a resultant that does not pass through

the centre of mass (see Fig. 53), the centre of mass will, nevertheless, move with uniform acceleration in a straight line, so that, *if the body also turns, it must be about an axis through the centre of mass.*

PROPOSITION VII.—(Dynamical.) *The application of a couple to a rigid body at rest and free to move in any manner, can only cause rotation about some axis through the centre of mass.*

For, by Proposition VI,

$$\text{Acceleration of centre of mass} = \frac{\Sigma E}{\Sigma m},$$

but in the case of a couple $\Sigma E=0$ for every direction, so that the centre of mass has no acceleration due to the couple, which, therefore (if the body were moving), could only add rotation to the existing motion of translation.

PROPOSITION VIII.—(Dynamical.) *When any system of forces is applied to a free rigid body, the effect on the rotation about any axis fixed in direction, passing through the Centre of Mass and moving with it, is independent of the motion of the Centre of Mass.*

For, by the note on Chapter II., p. 32,

$$\Sigma \left(\begin{array}{l} \text{moments of the mass-} \\ \text{accelerations about any} \\ \text{axis fixed in space} \end{array} \right) \left. \vphantom{\Sigma} \right\} = \begin{array}{l} \text{Resultant moment of the} \\ \text{external forces} \end{array}$$

$$\text{or } \Sigma(pma) = L$$

but, by Proposition V. (see Fig. 59, p. 103),

$$\Sigma(pma) = \Sigma(p'ma) + OG \Sigma(ma')$$

$$\therefore \Sigma(p'ma) + OG \Sigma(ma') = L.$$

If, now, the centre of mass be, at the instant under consideration, passing through the fixed axis in question (which is equivalent to the axis passing through the Centre of Mass and moving with it), $OG=0$ and the second term vanishes

$$\text{and } \Sigma(\rho ma) = I, \text{}$$

i.e. the sum of the moments of the mass-accelerations about such a moving axis = resultant moment of the external forces, precisely as if there had been no motion of the Centre of Mass. This proposition justifies the **independent treatment of rotation and translation** under the influence of external forces.

On the direction of the Axis through the Centre of Mass, about which a couple causes a free Rigid Body to turn.—*Caution.*—The reader might be at first disposed to think that rotation must take place about an axis perpendicular to the plane of the applied couple, especially as the experiments quoted do not reveal the contrary; but it should be observed that the experiment of the floating magnet was not such as would exhibit satisfactorily rotation about any but a vertical axis.

It is not difficult to show that rotation will not in general

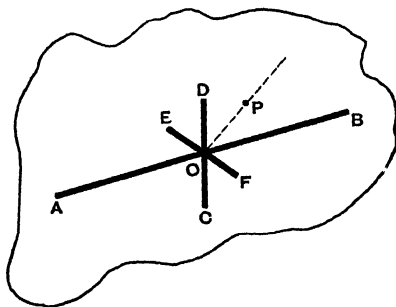

FIG. 60.

begin about the axis of the couple. To fix the ideas, let us imagine a body composed of three heavy bars crossing each other at right-angles, at the same point O, which is the centre of mass of the whole system, and let

the bar AB be much longer and heavier than either of the other two CD and EF, and let this massive system be embedded in surrounding matter whose mass may be neglected in comparison.

It is evident that the moment of inertia of such a system is much less about AB than about CD or EF, or that it will be easier to rotate the body about AB than about CD or EF. Hence, if a couple be applied, say by means of a force through the centre of mass along EF, and an equal and opposite force at some point P on the bisector of the angle DOB, then this latter force will have equal resolved moments about CD and about AB. But rotation will begin to be generated more rapidly about the direction of AB than about that of CD, and the resulting axis of initial rotation will lie nearer to AB than to CD, and will not be perpendicular to the plane of the couple. In fact, the rods EF and CD will begin to turn about the original direction of AB, considered as fixed in space, while at the same time the rod AB will begin to rotate about the axis CD, considered as fixed, but with a more slowly increasing velocity. We shall return to this point again in Chapter XII.

Total Kinetic Energy of a Rigid Body.—When a body rotates with angular velocity (ω) about the centre of mass, while this has a velocity (v), we can, by a force through the centre of mass destroy the kinetic energy of translation ($\frac{1}{2}Mv^2$) leaving that of rotation ($\frac{1}{2}I\omega^2$) unaltered. Thus,

$$\text{the total kinetic energy} = \frac{1}{2}Mv^2 + \frac{1}{2}I\omega^2.$$

In the examples that follow on p. 110, this consideration often gives the readiest mode of solution.

Examples.

(1) Two masses M and m , of which M is the greater, hang at the ends of a weightless cord over a smooth horizontal peg, and move under the action of gravity; to find the acceleration of their centre of mass and the upward pressure of the peg.

Taking the downward direction as +ve, the acceleration of M is $g \frac{M-m}{M+m}$ while that of m is $-g \frac{M-m}{M+m}$. Hence substituting in the general expression for the acceleration of the centre of mass,

viz., $\bar{a} = \frac{\Sigma(ma)}{\Sigma m}$ we have

$$\bar{a} = \frac{Mg(M-m) - mg(M-m)}{(M+m)^2} = g \frac{(M-m)^2}{(M+m)^2}$$

The total external force which produces this acceleration is the sum of the weights - the push P of the peg;

$$\therefore (M+m)g - P = (M+m)g \frac{(M-m)^2}{(M+m)^2}$$

$$\text{or } P = (M+m)g \left[1 - \frac{(M-m)^2}{(M+m)^2} \right]$$

$$= (M+m)g \frac{4Mm}{(M+m)^2}$$

$$= \frac{4Mmg}{M+m} \text{ absolute units of force.}$$

(2) A uniform solid sphere rolls without slipping down a plane inclined at an angle θ with the horizontal; to find the acceleration of its centre and the tangential force due to the friction of the plane.

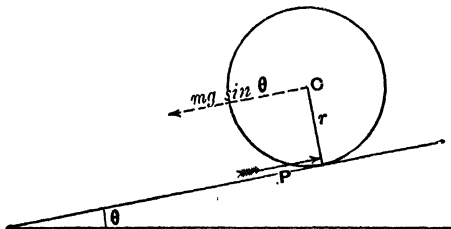

FIG. 60A.

It is evident that if there were no friction the sphere would slide and not roll, and therefore that the acceleration (a) of the centre C , which we wish to find is due to a total force $mg \sin \theta - P$ parallel to

the plane, where P is the friction.

$$\begin{aligned} \therefore a &= \frac{mg \sin \theta - P}{m}, \text{ where } m = \text{the mass of the sphere,} \\ &= g \sin \theta - \frac{P}{m} \quad . \quad . \quad . \quad . \quad (i) \end{aligned}$$

Now, the moment of the force (P) with reference to a horizontal axis through C is Pr , and, therefore, calling the angular acceleration of the sphere A, and its radius of gyration k ,

$$Pr = AI = A \times mk^2 \quad . \quad (ii)$$

$$\therefore \frac{P}{m} = \frac{Ak^2}{r}$$

\therefore substituting in (i)

$$a = g \sin \theta - \frac{Ak^2}{r}$$

Now, since the sphere is at any instant turning about the point of contact with the plane, we have $\omega = \frac{v}{r}$ and $A = \frac{a}{r}$ (iii)

\therefore substituting in the equation, we get

$$\begin{aligned} a &= g \sin \theta - \frac{ak^2}{r^2} \\ \text{or } a &= \frac{g \sin \theta}{1 + \frac{k^2}{r^2}} \\ &= g \sin \theta \frac{r^2}{r^2 + k^2} \end{aligned}$$

In the case of a sphere $k^2 = \frac{r^2 + r^2}{5} = \frac{2}{5}r^2$

$$\therefore a = g \sin \theta \times \frac{5}{7}$$

Hence, equating the total force to the mass-acceleration down the plane,

$$mg \sin \theta - P = mg \sin \theta \times \frac{5}{7}$$

$$\therefore P = \frac{2}{7}mg \sin \theta$$

[This question might also have been solved from the principle of the Conservation of Energy.]

Examples for Solution.

(1) Show that when a coin rolls on its edge in one plane, one-third of its whole kinetic energy is rotational.

(2) Show that when a hoop rolls in a vertical plane, one-half of its kinetic energy is rotational.

(3) Show that when a uniform sphere rolls with its centre moving along a straight path, $\frac{2}{3}$ of its kinetic energy is rotational.

(4) Find the time required for a uniform thin spherical shell to roll from rest 12 feet down a plane inclined to the horizontal at a slope of 1 in 50. Ans. 8 seconds (nearly).

(5) You are given two spheres externally similar and of equal weights, but one is a shell of heavy material and the other a solid sphere of lighter material. How can you easily distinguish between them?

(6) A uniform circular disc, half an inch thick and 12 inches in radius, has a projecting axle of the same material half an inch in diameter and 4 inches long. The ends of this axle rest upon two parallel strips of wood inclined at a slope of 1 in 40, the lower part of the disc hanging free between the two. The disc is observed to roll through 12 inches in 53.45 seconds. Deduce the value of g correct to 4 significant figures. Ans. $g = 32.19$ f.s.s.

(7) What mass could be raised through a space of 30 feet in 6 seconds by a weight of 50 lbs., hanging from the end of a cord passing round a fixed and a moveable pulley, each pulley being in the form of a disc and weighing 1 lb. Ans. 84.02 lbs.

Instructions.—Let M be the mass required. Its final velocity at the end of the six seconds will be twice the mean velocity, i.e. $2 \times \frac{30}{6}$ f.s. = 10 f.s. From this we know all the other velocities, both linear and angular—taking the radius of each pulley to be r . Equate the sum of the kinetic energies to the work done by the earth's pull. Remember that the fixed pulley will rotate twice as fast as the moveable one.

(8) A uniform cylinder of radius r , spinning with angular velocity ω , about its axis, is gently laid, with that axis horizontal, on a horizontal table with which its co-efficient of friction is μ . Prove that it will skid for a time $\frac{r\omega}{3\mu g}$ and then roll with uniform velocity $\frac{r\omega}{3}$.

CHAPTER X.

CENTRIPETAL AND CENTRIFUGAL FORCES.

WE have, so far, dealt with rotation about a fixed axis, or rather about a fixed material axle, without inquiring what forces are necessary to fix it. We shall now consider the question of the pull on the axle.

PROPOSITION.—*Any particle moving with uniform angular velocity ω round a circle of radius r must have an acceleration $r\omega^2$ towards the centre, and must therefore be acted on by a force $mr\omega^2$ towards the centre, where m is the mass of the particle.*¹

Let us agree to represent the velocity (v) of the particle at A by the length OP measured along the radius OA at right angles to the direction of the velocity. Then the

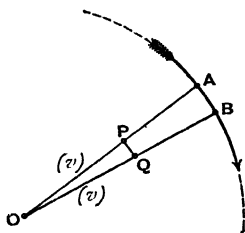

FIG. 62.

velocity at B is represented by an equal length OQ measured along the radius OB, and the velocity added in the interval is (by the triangle of velocities) represented by the line PQ.

If the interval of time considered be very short, B is very near to A and Q to P, and PQ is sensibly perpendicular to the radius

¹ Since $\omega = \frac{v}{r}$, $r\omega^2 = \frac{v^2}{r}$, and it is proved in text-books on the dynamics of a particle, such as Garnett's *Elementary Dynamics* and Lock's *Dynamics*, that the acceleration of a point moving uniformly in a circle with speed v is towards the centre, and is $\frac{v^2}{r}$: thus the Student will be already familiar with the proposition. We give, however, a rather different proof.

OA, and therefore the velocity it represents is along this radius and towards the centre. This shows that the addition of velocity, *i.e.* the acceleration, is towards the centre.

Let the very short interval in question be called (dt) . Then PQ represents the velocity added in time (dt) , *i.e.* the acceleration $\times (dt)$.

$$\therefore \frac{PQ}{OP} = \frac{\text{acceleration} \times (dt)}{v}$$

$$\text{But } \frac{PQ}{OP} = \text{angle } POQ = \omega(dt)$$

$$\therefore \frac{\text{acceleration} \times (dt)}{v} = \omega(dt)$$

$$\therefore \text{acceleration} = v\omega = r\omega^2.$$

Hence, if the particle have a mass m , the **centripetal** or centre-seeking *force* required to keep it moving with uniform speed in a circle of radius r is a force of $\frac{mv^2}{r}$ or $mr\omega^2$ units.

The unit force is here, as always, that required to give unit acceleration to unit mass. Thus, if the particle has a mass of m lbs., and moves with speed v feet per second in a circle of radius r feet, the force is $\frac{mv^2}{r}$ or $mr\omega^2$ *poundals*; while if the particle have a mass of m grams and move with velocity of v centimetres per second in a circle of radius r centimetres, then the centripetal force is $m\frac{v^2}{r}$ dynes.

Illustrations of the use of the terms 'Centripetal Force' and 'Centrifugal Force.'—A small bullet whirled round at the end of a long fine string approximates to the case of a heavy particle moving under the influence of a *centripetal* force. The string itself is pulled away from the centre by the bullet, which is said to exert on it a *centrifugal* force. Similarly a marble rolling round the groove at the

rim of a solitaire-board is kept in its circular path by the centripetal pressure exerted by the raised rim. The rim, on the other hand, experiences an equal and opposite centrifugal push exerted on it by the marble.

In fact, a particle of matter can only be constrained to move with uniform angular velocity in a circle by a centripetal force exerted on it by other matter, and the equal and opposite reaction exerted by the body in question is in most cases a centrifugal force. Thus, when two spheres attached to the ends of a fine string rotate round their common centre of gravity on a smooth table, each exerts on the string a centrifugal force. In the case, however, of two heavenly bodies, such as the earth and moon, rotating under the influence of their mutual attraction about their common centre of gravity, the force that each exerts on the other is centripetal. We cannot in this case *perceive* anything corresponding to the connecting string or to the external rim.

Centripetal Forces in a Rotating Rigid Body.—

When we have to deal, not with a single particle, but with a rigid body rotating with angular velocity ω , and of which the particles are at different distances, r_1, r_2, r_3 , etc., from the axis, it becomes necessary to find the resultant of the forces $(m_1 r_1 \omega^2), (m_2 r_2 \omega^2)$, etc., on the several particles.

Rigid Lamina.—We take first the case of a rigid lamina of mass M turning about an axle perpendicular to its plane. Here all the forces lie in one plane, and it is easily shown that the resultant required is a single force, through the centre of mass of the lamina, and equal to $MR\omega^2$, where R is the distance from the axis to the centre of mass; [and $MR\omega^2$, again, is equal to $M \frac{V^2}{R}$, where V is the speed of the centre of mass in its circular path].

This may be shown at once from the following well-known proposition in Statics: 'If two forces be represented in

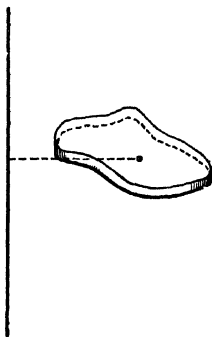

FIG. 63.

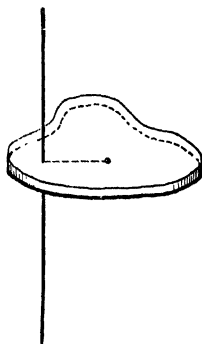

FIG. 64.

magnitude and direction by m times OA and n times OB , then their resultant is represented in magnitude and direction by $(m+n)$ times OC ,

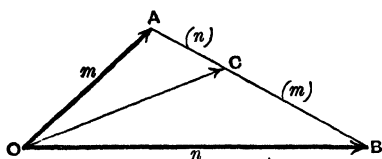

FIG. 65.

C being a point which divides the line AB , so that the ratio $\frac{AC}{CB} = \frac{n}{m}$,

(For proof see Greave's *Statics*, p. 18.) For let

A and B be any two particles of the lamina, and let their masses be m and n , then the force along OA is $m\omega^2 OA$, and that along OB is $n\omega^2 OB$; therefore, by the proposition quoted, the resultant force is $(m+n)\omega^2 OC$, and passes through C , which, since it divides the distance AB inversely as the masses, is the centre of mass and centre of gravity of the two particles. This resultant may next be combined with the force on a third particle of the rigid system, and so on till all are included.

Extension to Solids of a certain type.—By piling up laminæ whose centres of gravity all lie on the same

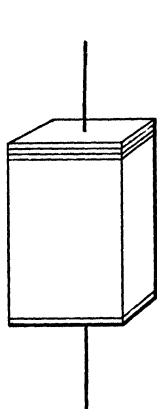

FIG. 66.

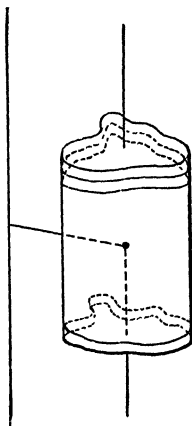

FIG. 67.

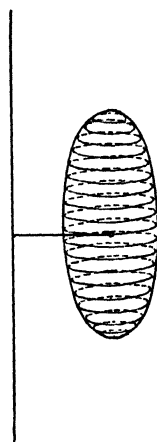

FIG. 68.

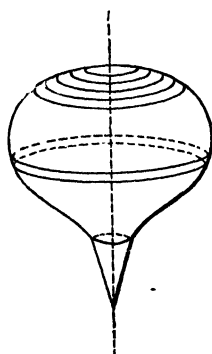

FIG. 69.

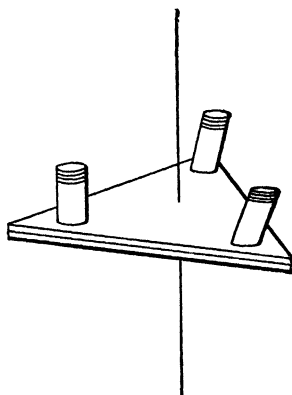

FIG. 70.

line parallel to the axis, as indicated in the diagrams (Figs. 66-70), we may build up solids of great variety of shape, and

by then combining resultants on the several laminae, we see that in order to keep the body rotating with uniform angular velocity, we require only a single force passing through its centre of gravity, and directed towards the axis and equal to $MR\omega^2$, where M is the mass of the whole body.

The requisite force might, in such a case, be obtained by connecting the centre of gravity of the body to the axis by a string. The axis would then experience a pull $MR\omega^2$, which changes in direction as the body rotates.

If the axis passes through the centres of mass of all such laminae, then $R=0$, and the force disappears, and the axis is unstrained. It is often of high importance that the rapidly rotating parts of any machinery shall be accurately centred, so that the strains and consequent wear of the axle may be avoided.

Convenient Dynamical Artifice. — It should be observed that the single force applied at the centre of mass would not supply the requisite centripetal pressure to the individual particles elsewhere if the body were not rigid. If, for example, the cylinder AB rotating as indicated about OO' consisted of loose smooth particles of shot or sand, it would be necessary to enclose these in a rigid case in order that the single force applied at G should maintain equilibrium. The particles between G and A would press against each other and against the case, and tend to turn it round one way, while those between G and B would tend, by their centrifugal pressure, to turn it the other way. Now, it is very convenient in dealing with problems involving the consideration of centripetal forces to treat the question as one

of the equilibrium of a case or shell, which we may regard as possessing rigidity, but no appreciable mass, and which is honey-combed throughout by minute cells, within which the massive particles may be conceived to lie as loose cores exerting on the cell-walls centrifugal pressures, whose resultant must be balanced by some external force, or system of forces, if the equilibrium is to be maintained.

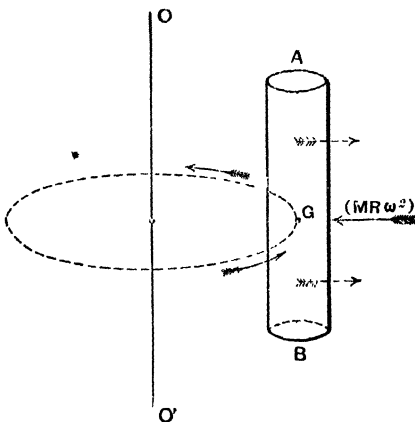

FIG. 71.

By the aid of this artifice, for the use of which the student will find plenty of scope in the examples that are given in the text-books of Garnett, or Loney, or Lock, already referred to, the problem of finding the forces necessary to maintain equilibrium may be dealt with as one in Statics.

Centrifugal Couples.—Let us now, using the method of this artifice, consider the revolution about the axis OO' of a thin uniform rod AB (Fig. 72). So long as the rod is parallel to the axis, a single force at its centre of gravity G suffices for equilibrium; but if the rod be tilted towards the axis, as shown in the figure, then it is evident that the centrifugal forces on the part AG are diminished, while those on GB are equally increased (the force being everywhere proportional to the distance from the axis); hence the resultant now to be sought

is that of the system indicated by the arrows in the figure,

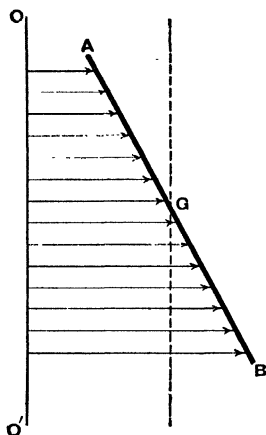

FIG. 72.

which is easily seen to be, as before, a single force of magnitude $MR\omega^2$, but which now passes through a point in the rod between G and B, and therefore has a moment about G. Such a force is equivalent to an equal parallel force through G, together with a couple in a plane containing G and the axis. Such a couple is called a **Centrifugal Couple**. It is evident that though, when the rod is parallel to the axis (attached to it, for example, by a string to the centre of mass), there is no centrifugal couple, yet the equilibrium, though it exists, is unstable,

for the slightest tilt of either end of the rod towards the axis will produce a centrifugal couple tending to increase the tilt. It is for this reason that a stick whirled by a cord attached to its centre of mass always tends to set itself radially.

Centrifugal Couple in a body of any shape.—With a body of any shape whatever rotating about a fixed axis, the same conclusion is arrived at, viz., that the centrifugal forces (due to the interior mass on the outside visible shell) are equivalent always to a single force $MR\omega^2$ applied at the centre of mass of the body, and a couple in a plane parallel to the axis; but the axis of this couple will not, except in special cases, be perpendicular to the plane containing the centre of gravity and the axis of rotation.

This result may be reached by taking, first, any two particles of the body, such as A and B in the diagram, of masses m and n respectively, and

showing that the centrifugal forces p and q exerted by each are equivalent to two forces along CA' and CB' (the directions of the projections of p and q on a plane perpendicular to the axis and containing the centre of mass of the two particles), together with the two couples pp' and qq' . Then the two coplanar forces along CA' and CB' have, as before (see p. 114), a resultant $(m+n)\omega^2 CG$, while the two couples combine into a single resultant couple in a plane

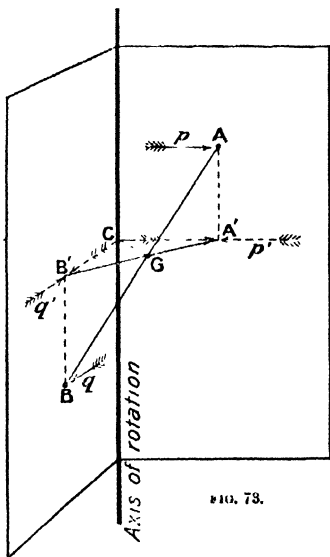

parallel to or containing the axis of rotation but not parallel to CG . In this way, taking all the particles in turn, we arrive at the single force through the centre of mass of the whole and a single couple.

Centrifugal Couples vanish when the rotation is about a Principal Axis, or about an Axis parallel thereto.—It is obvious that in the case of a thin rod (see Fig. 72) there is no centrifugal couple when the rod is either parallel or perpendicular to the axis of rotation, which is then a principal axis (or parallel to a principal axis), and it is easy to show that for a rigid body of any shape the centrifugal couples vanish when the rotation is about a principal axis.

Proof.—Let us fix our attention on any particle P of a body which rotates with uniform positive angular velocity ω_y , about

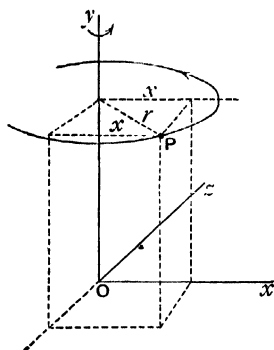

FIG. 73A.

a fixed axis Oy passing through the centre of mass O of the body. Let Ox and Oz be any two rectangular axes perpendicular to Oy . The centripetal force on the particle is always equal to $mr\omega_y^2$ (see Fig. 73A), and its component parallel to Ox is $-mx\omega_y^2$ (negative in sign because it tends to decrease x), and this changes the value of the momentum of the particle perpendicular to the plane yz . The moment about Oz

of this component of the centripetal force is $-\omega_y^2 mxy$ and measures the rate at which angular momentum is being generated about Oz . The sum of the moments of such components for all the particles of the body is $-\omega_y^2 \sum mxy$, and this with its sign changed, or $\omega_y^2 \sum mxy$, is the measure of the centrifugal couple about Oz . Now $\sum mxy$ vanishes when either x or y is a principal axis of the body (see pp. 59 and 60). Hence there is no centrifugal couple when the body rotates about a principal axis.

It follows that a rigid body rotating about a principal axis, and unacted on by any external torque, will rotate in equilibrium without the necessity of being tied to the axis. But in the case of bodies which have the moments of inertia about two of the principal axes equal, the equilibrium, as we have seen, will not be stable unless the axis of rotation is the axis of greatest moment.

Importance of properly shaping the parts of machinery intended to rotate rapidly.—In connection with this dynamical property of principal axes, the student will now recognise the importance of shaping and balancing the rotating parts of machinery, so that not merely shall the axis of rotation pass through the centre of mass, but it shall also be a *principal axis*, since in this way only can injurious stresses on the axle be completely avoided.

Equipomental bodies similarly rotating have equal and similar centrifugal couples.—*Proof.*—Let x_1, y_1, z_1 be any three rectangular axes of the one body (1), and x_2, y_2, z_2 the corresponding axes of the other (2), and let A', B', C' be the respective moments of inertia about these axes. Then about any other axis, in the plane xy making any angle α with (x) , $\beta (=90^\circ - \alpha)$ with (y) , and $\gamma (=90^\circ)$ with (z) , the moment of inertia of (1) is (as we see by referring to p. 60),

$$A' \cos^2 \alpha + B' \cos^2 \beta - 2 \sum m x_1 y_1, \cos \alpha \cos \beta,$$

while that of (2) about a corresponding axis is

$$A' \cos^2 \alpha + B' \cos^2 \beta - 2 \sum m x_2 y_2 \cos \alpha \cos \beta$$

(for the terms involving $\cos \gamma$ as a factor disappear since $\cos \gamma = \cos 90^\circ = 0$), and, since the bodies are equipomental, these two expressions are equal, therefore

$$\sum m x_1 y_1 = \sum m x_2 y_2.$$

Therefore for equal rates of rotation about either x or y , the centrifugal couples about (z) are equal, and this is true for all corresponding axes.

Substitution of the 3-rod inertia-skeleton.—This result justifies us in substituting for any rotating rigid body

its three-rod inertia-skeleton, the centrifugal couples on which can be calculated in a quite simple way. We will take first a solid of revolution, about the axis of minimum inertia C. For such a body the rod C is the longest, and the two rods

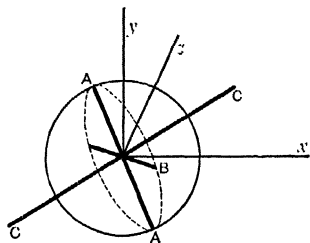

FIG. 73B.

A and B are equal, and these two, together with an equal length measured off the central portion of the third rod (C), combine to form a system dynamically equivalent to a sphere for which all centrifugal couples vanish about all axes; there thus remains for consideration only the

excess at the ends of the rod C (see Fig. 73B). The centrifugal couple is in this case obviously about an axis perpendicular to the plane (xy) containing the rod C and the axis of rotation (y), and its value, as we have seen, is $\omega^2 \Sigma mxy$; now if r be the distance of a particle from the origin O, $x=r \sin \theta$ and $y=r \cos \theta$, $\therefore \omega^2 \Sigma mxy = \omega^2 \sin \theta \cos \theta \Sigma mr^2$, and

$\Sigma mr^2 =$ moment of inertia about z of the projecting ends of the rod C

$=$ moment of inertia of the whole rod C about a perpendicular axis—the moment of inertia of rod A about a perpendicular axis,

$= \frac{1}{2}(A+B-C) - \frac{1}{2}(B+C-A)$ (see p. 65)

$= A-C$

Therefore the centrifugal couple $= \omega^2(A-C) \sin \theta \cos \theta$.

If C had been the axis of maximum moment of inertia then the rod C would have been the shortest of the three rods instead of the longest, and we should have had a defect instead of an

excess to deal with, and the couple would have been of the opposite sign and equal to $\omega^2(C - A) \sin \theta \cos \theta$.

We shall make use of these results later on in connection with a spinning-top and gyroscope. (See Appendix.)

If all three moments of inertia are unequal, we could describe a sphere about the shortest rod as diameter, and should then have a second pair of projections to deal with. We could find, in the way just described, the couple due to each pair separately and then combine the two by the parallelogram law. We shall, however, not require to find the value of the couple except for solids of revolution.

Transfer of Energy under the action of Centrifugal Couples.—Returning again to our uniform thin

rod as a conveniently simple case, let us suppose it attached in the manner indicated in either figure (Figs. 74 and 75), so as to turn freely in the framework about the axle CC' , while this rotates about the fixed axis OO' . The rod, if liberated in the position shown, while the frame is

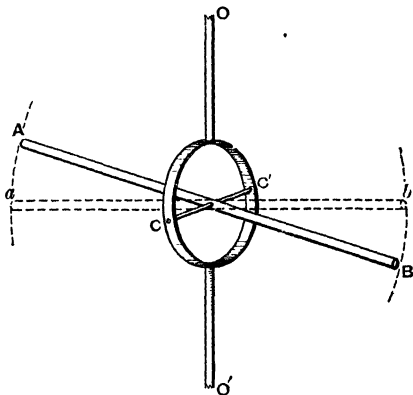

FIG. 74.

rotating, will oscillate under the influence of the centrifugal couple, swinging about the mean position ab . It is impossible in practice to avoid friction at the axle CC' , and these

oscillations will gradually die away, energy being dissipated as frictional heat. To the question, Where has this energy come from? the answer is, From the original energy of rotation of the whole system, for as the rod swings from the position AB to the position ab , its moment of inertia about OO' is being increased, and this by the action of forces having no moment about the axis, consequently, as we saw in Chapter VIII. p. 87, the kinetic energy due to rotation about OO' (estimated after the body has been fixed in a new position) must be diminished in exactly the same pro-

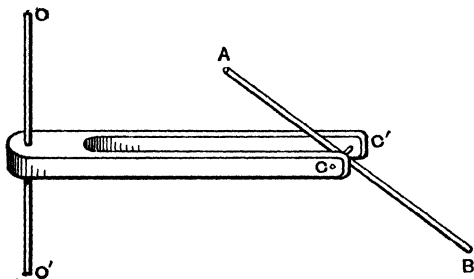

FIG. 75.

portion. Thus, if the whole system be rotating about OO' , and under the influence of no external torque, and with the rod initially in the position AB , then as the

rod oscillates, the angular velocity about O will alternately decrease and increase; energy of rotation about the axis OO' being exchanged for energy of rotation about the axis CC' .

CHAPTER XI.

CENTRE OF PERCUSSION.

LET a thin rod AB of mass m be pivoted at O about a fixed axle perpendicular to its length, and let the rod be struck an impulsive blow (P) at some point N, the direction of the blow being perpendicular to the plane containing the fixed axle and the rod, and let G be the centre of mass of the rod (which is not necessarily uniform).

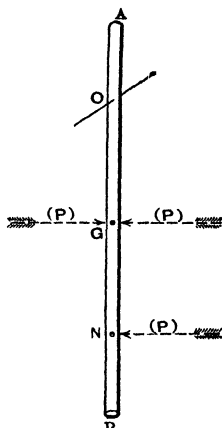

FIG. 76.

Suppose that simultaneously with the impulse (P) at N there act at G two opposed impulses each equal and parallel to (P). This will not alter the motion of the rod, and the blow is seen to be equivalent to a parallel impulse (P) acting through the centre of mass G, and an impulsive couple of moment $P \times GN$. On account of the former the body would, if free, immediately after the impulse be moving onwards, every part with the velocity $v = \frac{(P)}{m}$. On account of the latter it would be rotating about G with an angular velocity $\omega = \frac{(P) \times NG}{I}$.

Thus the velocity of any point, such as O on the opposite side of G to N, will, on one account, be to the left (in the figure), on the other to the right. If these opposite velocities are equal for the point O, then O will remain at rest, and the body will, for the instant, be turning about the axle through O, and there will be no impulsive strain on the axle. We shall investigate the length x that must be given to ON that this may be the case. Call OG (l) and let the radius of gyration of the bar about a parallel axis through the centre of mass be (k), then $GN = x - l$.

The velocity of O to the left is $\frac{P}{m}$.

“ “ “ right = $l\omega = l \frac{P \times (x-l)}{mk^2}$

These are equivalent when

$$\frac{lP(x-l)}{mk^2} = \frac{P}{m},$$

$$\text{i.e. when } \frac{lx - l^2}{k^2} = 1$$

$$\text{i.e. when } x = \frac{k^2 + l^2}{l} = \frac{K^2}{l}.$$

But this (see p. 77) is the length of the equivalent simple pendulum. If, therefore, the bar be struck in the manner described at a point M whose distance from the axis is the length of the equivalent simple pendulum, there will be no impulsive action on the axle. M is then called the *Centre of Percussion* of the rod.

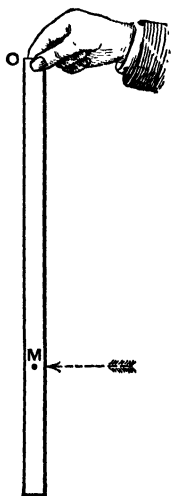

FIG. 77.

Experiment.—If a uniform thin rod (e.g. a yard measure) be lightly held at the upper end O, between the finger and thumb as shown, and

then struck a smart horizontal tap in the manner indicated by the arrow, it will be found that if the place of the blow be above the point M , situated at $\frac{1}{3}$ of the length from the bottom, the upper end will be driven from between the fingers in the direction of the blow (translation overbalancing rotation), while if the blow be below M the rotation of the rod will cause it to escape from the grasp in the opposite direction. If, however, the rod be struck accurately at M , the hand experiences no tug.

It is easy to show that from the point of support to M is the length of the equivalent simple pendulum, either by calculation (see Art. 12, p. 76), or by the direct experimental method of hanging both the rod and a simple pendulum of length OM from a pivot run through the rod at O , and observing that the two oscillate synchronously under the action of gravity.

It is evident that, even though the blow (P) be delivered at the right point, yet there will be an impulsive force on the axle unless (P) be also delivered in the right direction. For example, if the blow were not perpendicular to the rod, there would be an impulsive thrust or tug on the axle, while again, if the blow had any component *in* the plane containing the axle and the rod, the rod would jamb on the axle.

We have taken this simple case of a rod first for the sake of clearness, but the student will see that the reasoning would hold equally well for all cases in which the fixed axle is parallel to a principal axis through the centre of mass, and the blow delivered at a point on this axis, and perpendicular to the plane containing the axle and the centre of mass. Such cases are exemplified by

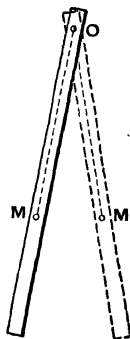

FIG. 78.

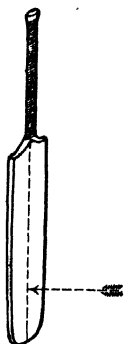

FIG. 79.

(i.) A cricket bat held in the hand as by a pivot, and struck by the ball somewhere in the central plane of symmetry, and perpendicular to the face.

(ii.) A thin vertical door struck somewhere along the horizontal line through its centre of mass, as is the case when it swings back against a 'stop' on the wall when flung widely open.

We see that the right position for the stop is at a distance of $\frac{1}{3}$ of the breadth of the door from the outer edge. (See Fig. 80.)

It is evident that the blow must be so delivered that the axis through the centre of mass about which the body, if free, would begin to turn, is parallel to the given fixed axle, otherwise the axle will experience an impulsive twist, such as is felt by a batsman or a racquet-player when the ball strikes his bat, to one side of the central plane of symmetry.

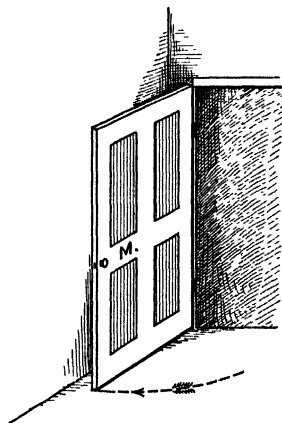

FIG. 80.

For this reason, too, a door that is brought up as it swings by a stop screwed to the floor, experiences a damaging twist at its hinges even though the stop be placed at the right distance from the line of hinges.

Centre of Percussion in a Body of any Form.—We have seen (p. 106) that a free rigid body, acted on by a

couple, will begin to rotate about an axis through its centre of mass, but not *in general* perpendicular to the plane of the couple, and it is evident that when a body can only turn about a fixed axle, and is struck by an impulsive couple, the axle will experience an impulsive twist of the kind described unless it is parallel to this axis of spontaneous rotation. Hence it is not possible, in all cases of a body turning about a fixed axle, to find a centre of percussion; and a criterion or test of the possibility is the following:—Through the centre of mass draw a line parallel to the fixed axle. Rotation about this line will, in general, involve a resultant centrifugal couple. If the plane of this couple contains the fixed axle, then a centre of percussion can be found, not otherwise. The significance of this criterion will be apparent after a reading of the next chapter.¹ It is easy, by imagining the body to be replaced by its inertia-skeleton of three rectangular rods, to see that if the fixed axle is parallel to one of the three rods, *i.e.* to one of *the* principal axes, there is always an easily found centre of percussion for a rightly directed blow.

N.B.—It should be observed that when once rotation has begun there will be a centrifugal pull on the axle, even though the blow has been rightly directed; but this force will be of finite value depending on the angular velocity imparted, and will not be an impulsive force. Our investigation is only concerned with impulsive pressures on the axle.

¹ See also Appendix, p. 168.

CHAPTER XII.

ESTIMATION OF THE TOTAL ANGULAR MOMENTUM.

It may not be at once apparent that rotation about a given fixed axle may involve angular momentum about an axis perpendicular thereto.

To explain this let us take, in the first instance, two simple illustrations.

Referring to Fig. 75, p. 124, let the rod AB be rotating without friction about the perpendicular axle CC' , while at the same time the forked framework which carries CC' is stationary but free to turn about OO' , and that when the rod is, for example, in the position indicated, its rotation about CC' is suddenly stopped.

It is clear that in this case the sudden stoppage cannot affect the angular velocity of the other parts of the system about OO' , for it can be brought about by the simple tightening of a string between some point on the fixed axle OO' and some point such as A or B on the rod, or by impact with a smooth ring that can be slipped down over the axle OO' as indicated in Fig. 81, *i.e.* by forces having no moment about OO' .

In order to test whether, in any case, the sudden stoppage

of rotation about CC' shall affect the angular velocity of other parts of the system about OO' , it is sufficient to inquire whether, when the rotation is only about CC' , the sudden stoppage involves the action of any impulsive couple about OO' .

In the case of the thin rod just examined the impulsive couple required is entirely in the plane of the axis OO' , being a tug at one place, and a thrust transmitted equally through each prong of the fork in another, and therefore has no moment about OO' .

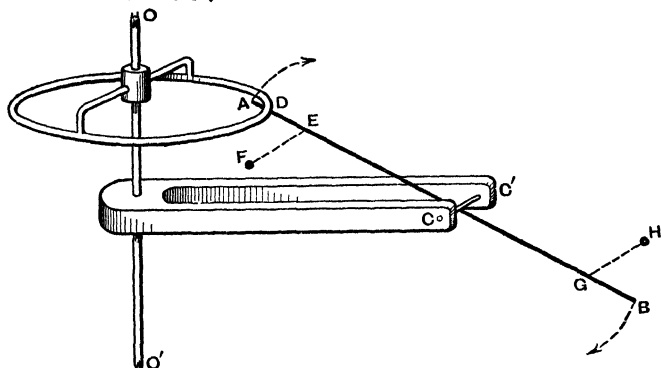

FIG. 81.

But if we suppose the simple bar to be exchanged for one with projecting arms EF and GH , each parallel to CC' and loaded, let us say, at the ends as indicated in the figure, then, on the sudden stoppage of the rod by the ring as before, the momentum of the loads at F and H will tend to produce rotation about AB , and therefore pressures at C and C' which will change the angular velocity of CC' about OO' . It is evident, in fact, that though we allow ourselves to speak of the loaded rod as simply rotating about CC' , yet that each of the

loads at F and H have angular momentum about OO' , and that when we suddenly stop the rotation about CC' , we also suddenly destroy this angular momentum about OO' , which requires the action of an impulsive couple about OO' . In the illustration in question this couple is supplied by other parts of the system, the reaction on which causes them to take up the angular momentum about OO' that is lost by the masses at F and H.

The reader will see that in the first case the amount of angular momentum existing at any instant about OO' is not affected by the simultaneous rotation about CC' , while in the second case it is. He will also notice that CC' is a principal axis in the first case, but not in the second.

Additional Property of Principal Axes.—Now it is easy to show by analysis that, for a rigid body of any shape, *Rotation about any given axis will in general involve angular momentum about any axis at right angles thereto, but not when one of the two is a principal axis.*

Let P (Fig. 73A, p. 120) be any particle of mass m , of a body which is rotating, say, in a *+ve* direction, about the axis Oy , with angular velocity ω_y . The velocity of P is perpendicular to r , and equal to $r\omega_y$; the component to this perpendicular to the plane xy , which alone has any moment about Ox , $=x\omega_y$, and its moment about $Ox = -\omega_y xy$ (negative because the rotation would be counter-clockwise as viewed from O), and therefore the moment of momentum of the particle about $Ox = -\omega_y mxy$, and summing for the whole body, the resultant angular momentum about $Ox = -\omega_y \sum mxy$, which

vanishes when either Ox or Oy is a principal axis of the body.¹ Similarly there is angular momentum about Oz equal to $-\omega_y \sum mxyz$, which also vanishes if Oz or Oy is a principal axis

Total Angular Momentum.—It will now be clear that even when a body rotates in rigid attachment to an axis fixed in space, unless this axis is a principal axis the angular momentum about it will not be the whole angular momentum, for there* will be some residual angular momentum about perpendicular axes which we must compound with the other by the parallelogram law to obtain the whole angular momentum. This completes the explanation of the fact already noticed on p. 107, that a body free to turn in any manner will not, when acted on by an applied couple, always begin to rotate about the axis of that couple. The axis of rotation will be such as to make the axis of *total* angular momentum agree with that of the couple.

The Centripetal Couple.—When we put together the result of the analysis just given with that of p. 120, we see that we have shown that

- (i) $-\omega_y^2 \sum mxy$ measures the moment of the centripetal couple about z ;
- (ii) $-\omega_y \sum mxy$ measures the contribution of angular momentum about x due to the rotation about y ;
and
- (iii) $-\omega_y \sum myz$ measures the contribution about z .

¹ If the rotation about CC' (Fig. 81) had been suddenly arrested when the loaded rod was perpendicular to OO' , each load would then have been at the instant moving parallel to OO' , and there would have been no moment of momentum about OO' . OO' would at this instant have been *parallel* to a principal axis of the body

Whence we see that

The moment of the centripetal couple about $z = \omega_y \times$ the contribution of angular momentum about x .

Since the moment of a couple is greatest about an axis perpendicular to its plane, it follows that when, through the swinging round of the body, the contribution of angular momentum about x reaches its maximum value, at that instant z is the axis of the couple, whose forces are thus

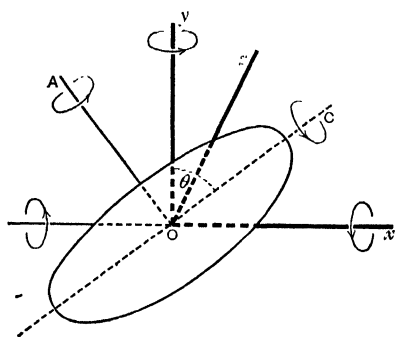

FIG. 81A.

seen to lie in the plane containing the axis of rotation and the axis of total angular momentum. (See Appendix, p. 164.)

We will now find in another way the residual angular momentum and the centrifugal couple. Let us take, for example, the case of a solid of

revolution rotating with angular velocity ω about an axis Oy making an angle θ with the minimum axis C . The centripetal couple is in the plane yx containing the axis C , and its moment about $z = \omega \times$ angular momentum about x . (See Fig. 81A.)

The angular velocity ω may be resolved into two components about the principal axes, viz., $\omega \sin \theta$ about OA and $\omega \cos \theta$ about OC . The angular momentum about OA is then $A\omega \sin \theta$, and about OC is $C\omega \cos \theta$.¹ The sum of the

¹ It is only because OA and OC are each principal axes that we can write the angular momentum about them as equal to the resolved part of the angular velocity \times the moment of inertia.

resolutes of these about Ox is

$$-A\omega \sin \theta \cos \theta + C\omega \cos \theta \sin \theta = -(A-C)\omega \cos \theta \sin \theta.$$

This multiplied by ω or $-\omega^2(A-C) \sin \theta \cos \theta$ is therefore the moment of the centripetal couple about z required to maintain the rotation. This result with the sign changed is the value of the centrifugal couple, and agrees with that obtained in a different way on p. 122.

Rotation under the influence of no torque.—A rigid body of which one point, say its centre of mass, is fixed can only move by turning about that point, and at any instant it must be turning about some line, which we call the instantaneous axis, passing through that point. Every particle on that line is for the instant stationary, though, in general, it will be gaining velocity (such particles will in fact have acceleration but not velocity). Hence after a short interval of time these same particles will no longer be at rest, and will no longer lie on the instantaneous axis. If, however, the axis of rotation is a principal axis, and no external forces are acting, there will be no tendency to move away from it, for there will be no centrifugal couple. We thus realise that if such a body be set rotating and then left to itself its future motion will depend on the direction and magnitude of the centrifugal couple. After it is once abandoned, however, the axis of total angular momentum must remain fixed in space; it is therefore often termed the *invariable* axis.

CHAPTER XIII.

ON SOME OF THE PHENOMENA PRESENTED BY SPINNING BODIES.

THE behaviour of a spinning top, when we attempt in any way to interfere with it, is a matter that at once engages and even fascinates the attention. Between the top spinning and the top not spinning there seems the difference almost between living matter and dead. While spinning, it appears to set all our pre-conceived views at defiance. It stands on its point in apparent contempt of the conditions of statical stability, and when we endeavour to turn it over, seems not only to resist but to evade us.

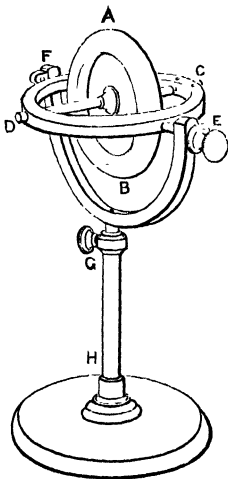

FIG. 82.

The phenomena presented are best studied in the Gyroscope, which may be described as a metal disc AB (see Fig. 82) with a heavy rim, capable of rotating with little friction about an axle CD, held, as shown in the figure, by a frame, so that the wheel can turn either about the axle CD, or (together with the frame CD) about the axle EF, perpendicular to CD, or about the axle

GH, perpendicular to every possible position of EF, or the wheel may possess each of these three kinds of rotation simultaneously.

The axle CD we shall refer to as the axle of spin, or axle (1), the axle EF we shall call axle (2), and the axle GH, which in the ordinary use of the instrument is vertical, we shall call axle (3). Suppose now the apparatus to be placed as shown in the figure, with both the axle of spin and axle (2) horizontal, and let rapid rotation be given to it about the axle of spin CD.

Experiment 1.—If, now, keeping GH vertical, we move the whole bodily, say by carrying it round the room, we observe that the axle of rotation preserves its direction unaltered as we go. This is only an illustration of the conservation of angular momentum. To change the direction of the axle of spin would be to alter the amount of rotation about an axis in a given direction, and would require the action of an external couple, such as, in the absence of all friction, is not present.

Experiment 2.—If, while the wheel is still spinning, we lift the frame-work CD out of its bearings at E and F, we find we can move it in any direction by a motion of translation, without observing anything to distinguish its behaviour from that of an ordinary non-rotating rigid body: but the moment we endeavour in any sudden manner to change the direction of the axle of spin an unexpected resistance is experienced, accompanied by a curious wriggle of the wheel.

Experiment 3.—For the closer examination of this resistance and wriggle let us endeavour, by the gradually applied pressure of smooth pointed rods (such as ivory penholders) downwards at D and upwards at C, to tilt the axle of spin—axle (1)—from its initial direction, which we will again suppose horizontal, so as to produce rotation about EF—axle (2). We find that the couple thus applied is resisted, but that the whole framework turns about the vertical axle GH—axle (3)—and continues so to turn as long as the pressures are applied, ceasing to turn when the couple is removed: the direction of the

rotation about axle (3) is counter-clockwise as viewed from above when the spin has the direction indicated by the arrows. (See Fig. 83.)

Experiment 4.—If, on the other hand, we endeavour by means of a gradually applied horizontal couple to impart to the already spinning wheel a rotation about axle (3), we find that instead of such rotation taking place, the wheel and its frame begin to rotate about the axle (2), and continue so to rotate so long as the couple is steadily applied. The direction of this rotation is that given in Fig. 84 below, and

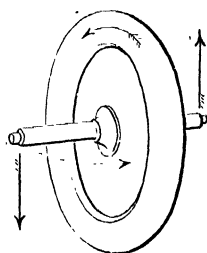

FIG. 83.

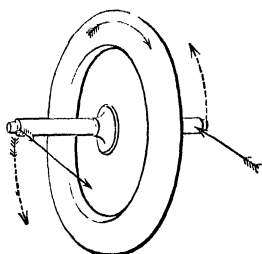

FIG. 84.

the effects here mentioned may be summarised by saying that with the disc rotating about axle (1) the attempt to impart rotation about a perpendicular axle is resisted, but causes rotation about a third axle perpendicular to both.

In each diagram the applied couple is indicated by straight arrows, the original direction of spin by unbroken curved arrows, and the direction of the rotation produced by the couple by broken curved arrows.

It should be noticed that it is only for convenience of reference that we suppose the axis of spin to be initially horizontal. Had this axis been tilted, and axle (3) placed perpendicular to it, the relation of the directions would be the same.

Definition.—The rotation of the axle of spin in a plane perpendicular to that of the couple applied to it is called a pre-

cessional motion—a phrase borrowed from Astronomy—and we shall speak of it by that name. The application of the couple is said to cause the spinning wheel to ‘precess.’

Rule for the direction of Precession.—In all cases the following Rule, for which the reason will be apparent shortly, will be found to hold.

The Precession of the axle of spin tends to convert the existing spin into a spin about the axis of the couple, the spin being in the direction required by the couple.

Experiment 5.—The actions just described may be well exhibited by attaching a weight at C or D, as in the accompanying figure

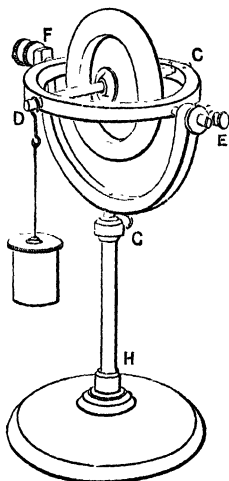

FIG. 85.

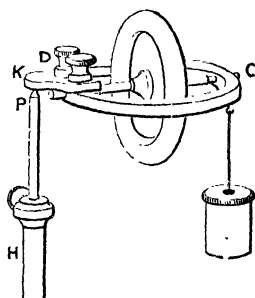

FIG. 86.

(Fig. 85), or still more strikingly, by supporting the frame CD on a point P, by means of a projection DK, in whose lower side is a shallow conical hollow, in the manner indicated in the figure (Fig. 86).

If the wheel were not spinning it would at once fall, but instead of falling it begins when released to travel with precessional motion round the vertical axis HP , and even the addition of a weight W to the framework at C will, if the rate of spin be sufficiently rapid, produce no obvious depression of the centre of gravity of the whole, but only an acceleration of the rate of precession round HP . It will, indeed, be observed that the centre of gravity of the whole does in time descend, though very gradually, also that the precession grows more and more rapid.

Each of these effects, however, is secondary, and due, in part at any rate, to friction, of which we can never get rid entirely.

In confirmation of this statement we may at once make the two following experiments.

Experiment 6.—Let the precession be retarded by a light horizontal couple applied at C and D . The centre of gravity at once descends rapidly. Let the precession be accelerated by a horizontal couple. The centre of gravity of the whole begins to rise. Thus we see that any friction of the axle GH in Fig. 85, or friction at the point P in Fig. 86, will cause the centre of gravity to descend.

Experiment 7.—Let Experiment 5 be repeated with a much smaller rate of original spin. The value of the steady precessional velocity will be much greater. Hence we see that friction of the axle of spin might account for the gradual acceleration of the precessional velocity that we observe.

Experiment 8.—Let us now vary the experiment by preventing the instrument from turning about the vertical axle (3), which may be done by tightening the screw G (Fig. 82), the base of the instrument being prevented from turning by its friction with the table on which it stands. If we now endeavour as before to tilt the rotating wheel, we find that the resistance previously experienced has disappeared, and that the wheel behaves to all appearance as if not spinning.

Experiment 9.—But if the stem GH be held in one hand, while with the other a pressure is applied at C or D to tilt the wheel, its ‘effort to precess’ will be strongly felt.

Experiment 10.—Let us now loosen the screw G again, but fix the frames CD , which may be done by pinning it to the frame EF , so as to prevent rotation about the axle EF . It will now be found that if, as in Experiment 4, we apply a horizontal couple, the previously felt resistance has disappeared; but here, again, the ‘effort to precess’ will be strongly felt if the framework CD be dismantled and held in the hand, and then given a sudden horizontal twist.

Precession in Hoops, Tops, etc.—It needs only the familiarity that most of us obtain as children with hoops, tops, bicycles, etc., to recognise that we have in these also the very same phenomenon of precession to explain. Thus, when a hoop rolling away from us is tilted over to the left, it nevertheless does not fall as it would if not rolling. Since the centre of gravity does not descend, the upthrust at the ground must be equal to the weight of the hoop, and must constitute with it a couple tending to turn the hoop over. We observe, however, that instead of turning over, the hoop turns to the left, *i.e.* it takes on a precessional motion.

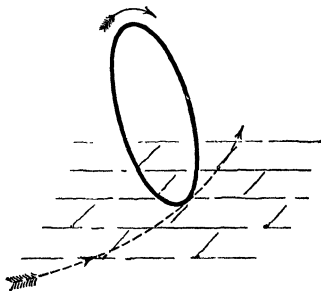

FIG. 57.

If we forcibly attempt with the hoop-stick to make it turn more quickly to the left, the hoop at once rears itself upright again (compare Experiment 6).

It is true that when the hoop is bowling along a curved path of radius R in an inclined position, as shown in the

figure, there is a couple acting on it in a vertical plane, due to the centrifugal force $\frac{mv^2}{R}$, and the lateral friction of the ground. But this will not account for the curvature of the track, nor can it be the sole cause of the hoop not falling over, for if the hoop be thrown from the observer in an inclined position, and spinning so as afterwards to roll back towards him, it will be observed not to fall over even while almost stationary, during the process of 'skidding,' which precedes the rolling back.

Further Experiment with a Hoop.—It is an instructive experiment to set a small light hoop spinning in a vertical plane, in the air, and then, while it is still in the air, to strike it a blow with the finger at the extremity of a horizontal diameter. The hoop will at once *turn over about* that diameter. If the experiment be repeated with the hoop not spinning, the hoop will not turn over, but will rotate about a vertical diameter. This experiment will confirm the belief in the validity of the explanation above given of the observed facts.

That a spinning top does not fall when its axis of spin is tilted is evidently an instance of the same kind, and we shall show¹ (p. 154) that the behaviour of a top in raising itself from an inclined to an upright position is due to an acceleration of the precession caused by the action of the ground against its peg, and falls under the same category as the recovery of position by the hoop, illustrated in experiments 4 and 6 with the gyroscope.

¹ See also p. 70 of a *Lecture on Spinning Tops*, by Professor John Perry, F.R.S. Published by the Society for Promoting Christian Knowledge, Charing Cross, London, W.C.

Bicycle.—In the case of a bicycle the same causes operate, but the relatively great mass of the non-rotating parts (the framework and the rider) causes the effect of their momentum to preponderate in importance. It is true that when the rider finds himself falling over to his left, he gives to his driving-wheel, by means of the handles, a rotation to his left about a vertical axis, and that this rotation will cause a precessional recovery on the part of the wheel of the erect position.* How considerable is this effort to precess may be readily appreciated by any one who will endeavour to change the plane of rotation of a spinning bicycle wheel, having first, for convenience of manipulation, detached it in its bearings from the rest of the machine. But if the turn given to the track be a sharp one, the momentum of the rider, who is seated above the axle of the wheel, will be the more powerful cause in re-erection of the wheel. It should also be noticed that the reaction to the horizontal couple applied by the rider will be transmitted to the hind wheel, on which it will act in the opposite manner, tending to turn it over still further, and at the same time to decrease the curvature of the



FIG. 88.

track, and thus the effect of the centrifugal and friction couple already alluded to in reference to the motion of a hoop.

Explanation of Precession.—That the grounds of the apparently anomalous behaviour of the gyroscope may be fully apprehended, it is necessary to remember that the principle of the conservation of angular momentum implies

(i) That the application of any external couple involves the generation of angular momentum at a definite rate about the axis of the couple; and (ii) That no angular momentum about any axis in space can be destroyed or generated in a body without the action of a corresponding external couple about that axis. Now, if the spinning wheel were to turn over under the action of a tilting couple as it would if not spinning, and as, without experience, we might have expected it to do, the latter of these conditions would be violated. For, as the wheel, whose axis of spin was, let us suppose, originally horizontal, turned over, angular momentum would begin to be generated¹ about a vertical axis without there being any corresponding couple to account for it; and if the tilting continued, angular momentum would also gradually disappear about the original direction of the axle of spin, and again without a corresponding couple to account for it.

On the other hand, by the wheel not turning over in obedience to the tilting couple, this violation of condition (ii) is avoided, and by its precessing at a suitable rate condition (i) is also fulfilled. For, as the wheel turns about the axis of precession, so fast does angular momentum begin to appear about the axis of the couple as required.

¹ When the wheel is *simply* spinning about axis (1) the amount of angular momentum about any axis in space drawn through its centre, is (see p. 89) proportional to the projection in that direction of the length of the axle of spin. Or again, the amount of angular momentum about any axis is proportional to the projection of the circular area of the disc which is visible to a person looking from a distance at its centre along the axis in question. Thus, if the axis were to begin to be tilted up, a person looking vertically down on the wheel would begin to see some of the flat side of the wheel. The student will find this a convenient method of following with the eye and estimating the development of angular momentum about any axis.

Analogy between steady Precession and uniform Motion in a Circle.—To maintain the uniform motion of a particle along a circular arc requires, as we saw on p. 111, the application of a force, which, acting always perpendicular to the existing momentum, alters the direction but not the magnitude of that momentum. Similarly, for the maintenance of a steady precession, we must have a couple always generating angular momentum in a direction perpendicular to that of the existing angular momentum, and thereby altering the direction but not the magnitude of that angular momentum.

We showed (pp. 111, 112) that to maintain rotation with angular velocity ω in a particle whose momentum was mv , required a central force of magnitude $m\omega v$, and we shall now find in precisely the same way, using the same figure, the value of the couple (L) required to maintain a given rate of precession about a vertical axis in a gyroscope with its axle of spin horizontal.

Calculation of the Rate of Precession.—Let ω be the rate of precession of the axle of spin. Let I be the moment of inertia of the wheel about the axle of spin.

Let Ω be the angular velocity of spin.

Then $I\Omega$ is the angular momentum of the wheel about an axis coinciding at any instant with the axle of spin.¹

It is to be observed, that in the absence of friction at the pivots, the rate of spin about the axle of spin remains unaltered.

¹ The student is reminded that, on account of the already existing precession, the angular momentum about the axle of spin would not be $I\Omega$ if this axle were not also a principal axis, and at right-angles to the axis of precession (see p. 132).

Let us agree to represent the angular momentum $I\Omega$ about the axle of spin when in the position OA by the length OP measured along OA . Then the angular momentum about the axle when in the position OB is represented by an equal length OQ measured along OB , and the angular momentum added in the interval is represented by the line PQ .

If the interval of time considered be very short, then OB is very near OA , and PQ is perpendicular to the axle OA . This shows that the angular momentum added, and therefore the external

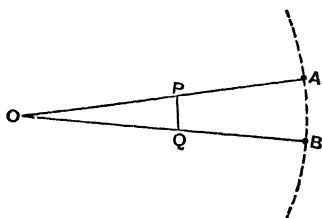

FIG. 89.

couple required to maintain the precession, is perpendicular to the axle of spin.

Let the very short interval of time in question be called (dt) , then PQ represents the angular momentum added in time (dt) , *i.e.* (the external couple) $\times (dt)$.

$$\therefore \frac{PQ}{OP} = \frac{\text{external couple} \times (dt)}{I\Omega}$$

$$\text{But } \frac{PQ}{OP} = \text{angle } POQ = \omega(dt);$$

$$\therefore \frac{\text{external couple} \times (dt)}{I\Omega} = \omega(dt),$$

$$\text{or external couple} = I\Omega\omega.$$

The analogy between this result and that obtained for the maintenance of uniform angular velocity of a particle in a circle becomes perhaps most apparent when written in the following form:—

‘To rotate the linear momentum mv with angular velocity

ω requires a force perpendicular to the momentum of magnitude $mv.\omega$.

‘While

‘To rotate the angular momentum $I\Omega$ with angular velocity ω requires a couple, about an axis perpendicular to the axis of the angular momentum, of magnitude $I\Omega\omega$.’

Since then $L = I\Omega\omega$

$$\omega = \frac{L}{I\Omega}$$

or the rate of precession is directly proportional to the magnitude of the applied couple, and inversely as the existing angular momentum of spin.

That the rate of precession (ω) increases as the rate of spin Ω diminishes has already been shown (see Experiments 5 and 7).

But the result obtained also leads to the conclusion that, when the rate of spin is indefinitely small, then the rate of precession is indefinitely great, which seems quite contrary to experience, and requires further examination.

To make this point clear, attention is called to the fact that our investigation, which has just led to the result that $\omega = \frac{L}{I\Omega}$, applies only to the *maintenance of an existing precession*, and not to the starting of that precession from rest. Assuming no loss of spin by friction, it is evident that there is more kinetic energy in the apparatus when precessing especially with its frame, than when spinning with axle of spin at rest. In fact, if i be the moment of inertia of the whole apparatus about the axle, perpendicular to that of spin, round which precession takes place, the kinetic energy is increased by the amount $\frac{1}{2}i\omega^2$, and this increase can only have been derived from work done by the applied couple at starting. Hence,

in starting the precession, the wheel must yield somewhat to the tilting couple.

Observation of the 'Wobble.'—This yielding may be easily observed if, when the wheel is spinning, comparatively slowly, about axis (1), we apply and then remove a couple about axis (2) in an impulsive manner, for example by a sharp tap given to the frame at C. The whole instrument will be observed to wriggle or wobble, and if close attention be paid, it will be noticed that the axle of spin dips (at one end), is quickly brought to rest, and then begins to return, swings beyond the original (horizontal) position, comes quickly to rest, and then returns again, thus oscillating about a mean position. Meanwhile, and concomitantly with these motions, the framework CD begins to precess round a vertical axis, comes to rest, and then swings back again. The two motions together constitute a rotation of either extremity of the axle of spin. If the rate of spin be very rapid, these motions will be found to be not only smaller in amplitude, but so fast as not to be easily followed by the eye, which may discern only a slight 'shiver' of the axle. Or, again, a similar effect may be observed to follow a sudden tap given when the whole is precessing steadily under the pressure of an attached extra weight.

It will probably at once, and rightly, occur to the reader that the phenomenon is due to the inertia of the wheel and its attached frame, etc., with respect to rotation about the axis of precession. To any particular value of a tilting couple, and for a given angular momentum of spin about axis (1), there must be, as we have seen, so long as the couple is applied, an appropriate corresponding value for the preces-

sional velocity, but this velocity cannot be at once acquired or altered. The inertia of the particles remote from the axis of precession enables them to exert forces resisting precession, and we have seen as an experimental result (Experiments 6 and 8), that when precession is resisted the wheel obeys the tilting couple and turns over, acquiring angular velocity about the axis of the couple. But the parts that resist precessional rotation must, in accordance with the principle that action and reaction are equal and opposite, themselves acquire precessional rotation. Hence, when the impulsive couple, having reached its maximum value, begins to diminish again, this same inertia has the effect of hurrying the precession, and we have also seen in Experiment 6, that to hurry the precession is to produce a (precessional) tilt opposite to the couple inducing the precession, and this action destroys again the angular velocity about the axis of the applied couple which has just been acquired. The wobble once initiated can only disappear under the influence of frictional forces.¹ Thus the wobbling motion is seen to be

¹ We can now see in a general way in what manner our equation must be modified if it is to represent the connection between the applied couple and the rate of precession during the wobble. The yielding under the applied couple implies that this is generating angular momentum about its own axis by the ordinary process of generating angular acceleration of the whole object about that axis, and thus less is left unbalanced to work the alternative process of rotating the angular momentum of spin. In fact, if our equation is to hold, we must write (in an obvious notation)

$$\mathbf{L} - I_2 \dot{\omega}_2 = \omega \times \text{angular momentum about horizontal axis perpendicular to the axis of the couple.}$$

But the motion being now much more complicated than before, the angular momentum about the horizontal axis that is being rotated can no longer be so simply expressed. As we have seen, it is not independent of $\dot{\omega}_2$.

the result of forces tending first to check and then to accelerate precession, a phenomenon that has been already observed. But to observe one phenomenon, and then to point out that another is of the same kind, cannot explain both, and it is still desirable to obtain further insight into the physical reactions between the parts, which enables a couple about axle 2 to *start* precession about axle 3, and *vice versa*.

Explanation of the Starting of Precession.—

Suppose that we look along the horizontal axis of spin at the broad-side of the disc spinning as indicated by the arrow (Fig. 90), and that there is applied to it a couple about axle (2) tending, say, to make the upper half of the disc advance towards us out of the plane of the diagram, and the lower half to recede. We shall show that simultaneously with the rotation that such a couple produces about axle (2), forces are called into play which start precession about (3).

All particles in quadrant (1) are increasing their distance from the axis (2), and therefore (see pp. 85 and 86) checking the rotation about (2), producing, in fact (on the massless rigid structure within the cells of which we may imagine them lying as loose cores), by reason of their inertia, the effect of a force away from the observer applied at some point A in the quadrant. Similarly, all particles in quadrant (2) are approaching the axis (2), and therefore by their momentum perpendicular to the plane of the diagram are accelerating the rotation about (2), producing on the rigid structure of the wheel the effect of a pressure towards the observer at some point B. In like manner, in quadrant (3), in which the particles are receding from axis (2), they exert

on the rigid structure a resultant force tending to check the rotation about (2), equal and opposite to that exerted at A, and passing through a point C similarly situated to A. Again, in quadrant (4) the force is away from the observer, is equal to that at B, and passes through the similarly situated point D. These four forces constitute a couple which does not affect the rotation about (2), but does generate precession about (3).

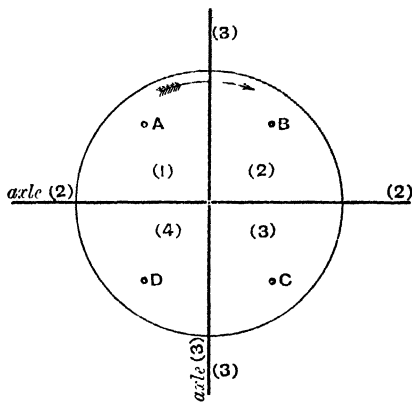

FIG. 90.

On the other hand, when precession is actually taking place about axis (3), we see, by dealing in precisely the same way with the several quadrants, and considering the approach or recession of their particles to or from axis (3), that the spin produces a couple about axis (2) which is opposed to and equilibrates the external couple that is already acting about axis (2), but which does not affect the rotation about axis (3).

If, when precession about (3) is proceeding steadily, the external couple about (2) be suddenly withdrawn, then this opposing couple is no longer balanced, and the momentum of the particles initiates a wobble by causing rotation about (2).¹

¹ Some readers may find it easier to follow this explanation by

Gyroscope with Axle of Spin Inclined.—It will be observed that we have limited our study of the motion of the

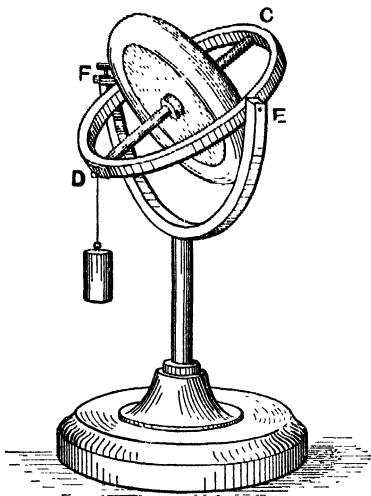

FIG. 91.

spinning gyroscope under the action of a tilting couple to the simplest case of all, viz., that in which the axle of spin is perpendicular to the vertical axle, which therefore coincides with the axis of precession. If we had experimented with the axle of spin inclined as in Fig. 91, then the axis of precession, which, as we have seen, must always be perpendicular to the axis of spin, would have been itself inclined,

and pure rotation about it would have been impossible owing to the manner in which the frame CD is attached to the vertical axle. The former precessional rotation could be resolved into two components, one about the vertical axis which can still take place, and one about a horizontal axis which is prevented.

Now, we have seen that the effect of impeding the precessional rotation is to cause the instrument to yield to the

imagining the disc as a hollow massless shell or case, inside which each massive particle whirls round the axis at the end of a fine string, and to think of the way in which the particles would strike the flat sides of the case if this were given the sudden turn about axle 2.

tilting couple. Hence we may expect to find that the sudden hanging on of a weight, as in the figure, will cause a more marked wobble of the axle of spin than would be produced by an equal torque suddenly applied when the axle of spin was horizontal. This may be abundantly verified by experiment. It will be found that if the instrument be turned from the position of Fig. 91 to that of Fig. 85, and the same tap be given in each case, the yield is far less noticeable in the horizontal position, although (since the force now acts on a longer arm) the moment of the tap is greater; and if other tests be applied, it will be observed that the quasi-rigidity of the instrument, even when spinning fast, is notably diminished when the axle of spin is nearly vertical, *i.e.* when nearly the whole of the precession is impeded.

Pivot-friction is liable to be greater with the axle of spin inclined, and this produces a more noticeable reduction of the rate of spin, with a corresponding increase of tilt and acceleration of the precession, which (as we show in the Appendix) would otherwise have a definite steady value. The precession also is now evidently a rotation about an axis which is not a principal axis of the disc, and on this account a centrifugal couple is called into play, tending, in the case of an oblate body like the gyroscope disc, to render the axle more vertical, *i.e.* to help the applied couple, if the weight is hung at the lower end of the axle, as in the figure, but to diminish the couple if the weight is hung from the upper end.

It must be remembered, however, that the disc of a gyroscope can only precess in company with its frame, CD, and the dimensions and mass of this can be so adjusted that the disc and frame together are dynamically equivalent to a sphere,

every axis being then a principal axis as regards a common rotation of disc and frame. In this manner disturbance by the centrifugal couple may be avoided.

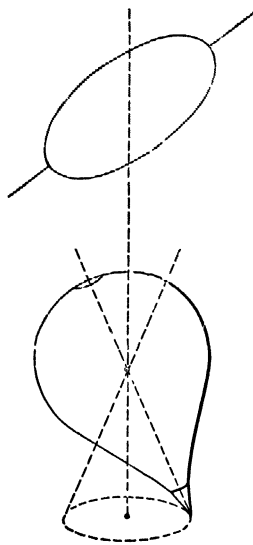

FIGS 92 AND 93.

In dealing with a peg-top moving in an inclined position with precessional gyration about a vertical axis (see Fig. 93), such centrifugal forces will obviously need taking into account. With a prolate top, such as that figured, the effect of the centrifugal couple will be to increase the applied couple and therefore the rate of precession; with a flattened or oblate top like a teetotum, to diminish it.

The exact evaluation of the steady precessional velocity of gyroscope or top with the axis of spin inclined will be found in the Appendix.

Explanation of the Effects of Impeding or Hurrying Precession.—Though we have throughout referred to these effects as purely experimental phenomena, the explanation is very simple. The turning over of the gyroscope, when the steady precession is impeded, is itself simply a precessional motion induced by the impeding torque. Reference to the rule for the direction of precession (p. 139) will show that the effect either of impeding or hurrying is at once accounted for in this way.

The Rising of a Spinning Top.—We have already

(p. 142) seen that this phenomenon would follow from the action of a torque hurrying the precession, and have intimated that it is by the friction of the peg with the ground or table on which the top spins that the requisite torque is provided. We shall now explain how this frictional force comes into play.

The top is supposed to be already spinning and precessing with its axis inclined as indicated in Fig. 93. * The relation between the directions of tilt, spin, and precession is obtained by the rule of page 139, and is shown by the arrows of Fig. 94, representing the peg of the top somewhat enlarged. The extremity of the

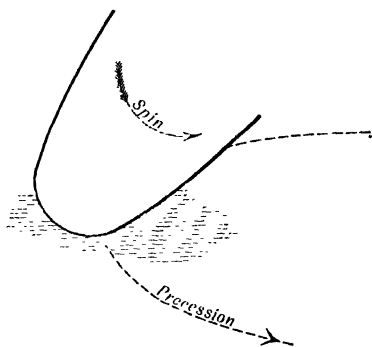

FIG. 94.

peg is always somewhat rounded, and the blunter it is, the farther from the axis of spin will be the part that at any instant is in contact with the table. On account of the precessional motion by which the peg is swept bodily round the horizontal circle on the table, this portion of the peg in contact with the table is moving forwards, while, on the other hand, on account of the spin, the same part is being carried backwards over the table. So long as there is relative motion of the parts in contact, the direction of the friction exerted by the table on the peg will depend on which of these two opposed velocities is the greater. If the forward, precessional velocity is the greater, then the friction will oppose precession and increase the tilt; while if the backward linear velocity due

to the spin is the greater, then the peg will skid as it sweeps round and the friction will be an external force aiding precession, and the top will rise to a more vertical position. When the two opposed velocities are exactly equal, then the motion of the peg is one of pure rolling round the horizontal circle: there is then no relative motion of the parts in contact, parallel to the table, and the friction may be in either direction, and may be zero.

With a very sharp peg, of which the part in contact with the table is very near the axis of spin, the backward linear velocity will be very small, even with a rapid rate of spin; so that such a top will less readily recover its erect position than one with a blunter peg. Also on a very smooth surface the recovery is necessarily slower than on a rough one, as may easily be seen by causing a top which is spinning and gyrating and slowly erecting itself on a smooth tray, to move on to an artificially roughened part.

The explanation here given, though somewhat more detailed, is essentially the same as that of Professor Perry in his charming little book on *Spinning Tops* already referred to, and is attributed by him to Sir William Thomson.

We will conclude by recommending the student to spin, on surfaces of different roughness, such bodies as an egg (hard-boiled), a sphere eccentrically loaded within, and to observe the circumstances under which the centre of gravity rises or does not rise. Bearing in mind the explanation just given, he should now be able to account to himself for what he will observe, and to foresee what will happen under altered conditions.

Calculation of the 'Effort to Precess.'—We saw,

in Experiments 9 and 10, that when precession is prevented an 'effort to precess' is exerted by the spinning body against that which prevents it. Thus, in the experiments referred to, pressures equivalent to a couple were exerted by the axle of the spinning wheel on its bearings.

If ω be the rate at which the axle of spin is being forcibly turned into a new direction, then $\omega I \Omega$ is the rate at which angular momentum is being generated about the axis perpendicular to the axis of ω and to that of Ω , and is therefore the measure of the torque exerted by the bearings, and of the reaction to which they are themselves in turn subjected.

Example (1).—A railway-engine whose two driving-wheels have each a diameter d ($=7$ feet) and a moment of inertia I ($=18500$ lb.-foot² units) rounds a curve of radius r ($=528$ feet) at a speed v ($=30$ miles per hour). Find the effort to precess due to the two wheels.

Solution—

$$\Omega = \frac{2v}{d} = 12.57 \text{ radians per second.}$$

$$\omega = \frac{v}{r} = \frac{44}{528} = \frac{1}{12} \text{ radians per second.}$$

\therefore Moment of couple required $= 2I\Omega\omega$ absolute units.
 $= 1200$ pound-foot units

(very nearly).

Applying the rule for the direction of precession, we see that this couple will tend to lift the engine off the inner rail of the curve.

[We have left out of consideration the inclination which, in practice, would be given to the wheels in rounding such a curve, since this will but slightly affect the numerical result.]

Similar stresses are produced at the bearings of the rotating parts of a ship's machinery by the rolling, pitching, and turning of the ship. In screw-ships the axis of the larger parts of such machinery are in general parallel to the ship's keel, and will therefore be altered in direction by the pitching and

turning, but not by the rolling. There appear to be no trustworthy data from which the maximum value of ω likely to be reached in pitching can be calculated.

As regards the effect of turning, the following example, for which the data employed were taken from actual measurements, shows that the stresses produced are not likely in any actual case to be large enough to be important.

Example (2).—A torpedo-boat with propeller making 270 revolutions per minute, made a complete turn in 84 seconds. The moment of inertia of the propeller was found, by dismounting it and observing the time of a small oscillation, under gravity, about a horizontal and eccentric axis, to be almost exactly 1 ton-foot². Required the precessional torque on the propeller shaft.

Solution—

$$\Omega = \frac{270 \times 2\pi}{60} = 28.3 \text{ radians per second.}$$

$$\omega = \frac{2\pi}{84} = \frac{11}{147} \text{ radians per second.}$$

$$I = 2240 \text{ lb.-foot}^2 \text{ units.}$$

$$\therefore \text{torque required} = I\Omega\omega \text{ absolute units.}$$

$$= 2240 \times 28.3 \times \frac{11}{147} \text{ poundal-foot units,}$$

$$= 148.4 \text{ pound-foot units (very nearly).}$$

This torque will tend to tilt up or depress the stern according to the direction of turning of the boat, and of rotation of the propeller.

MISCELLANEOUS EXAMPLES.

1. Find (a) the total angular momentum, (b) the position of the axis of total angular momentum, (c) the centrifugal couple in the two following cases :—

- (i) A uniform thin circular disc of mass M and radius r , rotating with angular velocity ω about an axis making an angle θ with the plane of the disc.
- (ii) A uniform parallelepiped of mass M and sides $2a$, $2b$, and $2c$, rotating with angular velocity (ω) about a diagonal.

2. A wheel of radius (r) and principal moments of inertia A and B , inclined at a constant angle (θ) to the horizon rolls over a horizontal plane, describing on it a circle of radius R , in T sec. Find (1) the position at any instant of the actual axis of rotation and the angular velocity about it; (2) the angular momentum about this axis; (3) the total angular momentum; (4) the position of the axis of total angular momentum; (5) the magnitude of the external couple necessary to maintain equilibrium.

3. Referring to Fig. 85, p. 139, if the moment of inertia of the spinning gyroscope about CD is 3000 gram-cm.² units, and if $CD = 10$ cm. and the value of the weight hung at $D = 50$ grams, and the rate of precession is observed to be 1 turn in 25 seconds, find the rate of spin of the gyroscope.

4. What would be the answer to the last question if the axis of spin had been inclined at an angle of 45° , as in Fig. 91, p. 152, the moment of inertia of the wheel about EF being 1800 gram-cm.² units, and the principal moments of inertia of the frame $CDEF$ being 2000 and 1100 units respectively?

APPENDIX

(1) ON THE TERMS ANGULAR VELOCITY AND ROTATIONAL VELOCITY.

WE can only speak of a *body* as having a definite angular velocity with respect to an axis, when every particle of the body has the same angular velocity about that axis, *i.e.* where the body, at the instant under consideration, is actually rotating about the axis in question. Thus for a *body* angular velocity means always rotational velocity, and either term may be used indifferently.

But a *particle* may have a definite angular velocity with respect to an axis about which it is not rotating.

Thus let P be a particle in the plane of the paper, moving with some velocity V , which may be inclined to the plane of the paper, but which has a resolute v in the plane of the paper in the direction APB (say). Let O be any axis perpendicular to the plane of the paper.

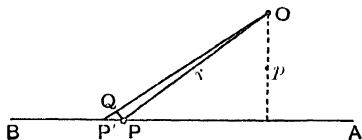

FIG. 95.

In any infinitesimal interval of time (dt) let the particle be carried from P to a point whose projection on the plane of the paper is P' ; then $PP' = vdt$. In the interval (dt) the projection of the radius vector has swept out the angle $POP' (= d\theta)$, and $\frac{d\theta}{dt}$ is called the angular velocity of the particle about the axis O, at the instant in question.

The measure of this angular velocity (ω) = $\frac{d\theta}{dt} = \frac{\angle POP'}{dt} =$

$$\frac{PQ}{OP} = \frac{PQ}{rdt} = \frac{PP' \times \frac{p}{r}}{rdt} = \frac{PP'}{dt} \times \frac{p}{r^2} = \frac{pv}{r^2}$$

Thus the angular velocity (ω) of any particle with respect to any axis at distance r , is obtained by finding the resolute (v) of its velocity, in a plane perpendicular to the axis, and drawing from the axis a perpendicular (p) on the direction of this resolute, then $\omega = \frac{pv}{r^2}$.

(2) ON THE COMPOSITION OF ROTATIONAL VELOCITIES.

Definition.—If a rigid body is rotating about some axle A, fixed to a frame, while the frame rotates about some axle B, fixed to a second frame, which in its turn rotates about a third axle C, fixed (say) to the earth, then the motion of the body relative to the earth's surface at the place where C is fixed, is said to be compounded at any instant of the three simultaneous rotations in question about A, B, and C, considered as fixed in the positions they occupy at that instant.

A similar definition applies to any number of simultaneous rotations.

(3) THE PARALLELOGRAM OF ROTATIONAL VELOCITIES.

ENUNCIATION.—If the motion of a rigid body of which one point O is fixed may at any instant be described by saying that it is rotating about the intersecting axes OA and OB with two simultaneous rotational velocities represented by the lengths OA and OB then, at the instant in question, the actual motion of the body is a rotation about and represented by OD, the diagonal of the parallelogram AB.

Proof.—Let ω_x be the (right-handed) rotational velocity about OA, and ω_y be the (right-handed) rota-

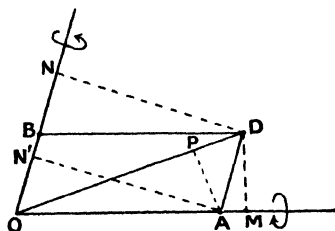

FIG. 96.

tional velocity about OB. Then the linear velocities of D on account of each separate rotation are perpendicular to the

plane of the diagram and the resultant linear velocity of D, towards the reader, is

$$\begin{aligned} & DM.\omega_x - DN.\omega_y \\ = & DM \times K.OA - DN \times K.OB \quad (\text{where } K \text{ is a constant depend-} \\ = & K(DM \times OA - DN \times OB) \quad \text{ing on the scale of repre-} \\ = & K(\text{arca } \Delta B - \text{arca } \Delta B) \quad \text{sentation)} \\ = & 0. \end{aligned}$$

\therefore The point D is at rest, *i.e.* OD represents the axis of rotation *in direction*. Also the actual rotational velocity ω about OD is represented in magnitude by OD, for

The linear velocity of a particle at A = ωAP
but also " " " " = $\omega_y AN'$.

$$\begin{aligned} \therefore \omega AP &= \omega_y AN' \\ &= K.OB.AN' \\ &= K \times \text{area } AB. \\ &= K \times 2 \times \text{area of } \Delta OAD. \\ &= K.OD \times AP \\ \therefore \omega &= K.OD \end{aligned}$$

i.e. OD represents the resultant rotational velocity on the scale already chosen.

The resultant OD may now be combined with a third component rotational velocity OC in any other direction and so on to any number of components.

Conversely, any rotational velocity may be resolved according to the parallelogram law into three independent rectangular components, as intimated in the text (p. 6).

The **Parallelogram of rotational accelerations** follows at once as a corollary, and thus rotational velocity, and rotational acceleration are each shown to be a vector quantity.

It is important, however, that the student should realise that rotational *displacements, if of finite magnitude*, are not vector quantities, for the resultant of two simultaneous or successive finite rotational displacements is not given by the

parallelogram law, and the resultant of two such successive finite displacements is not even independent of the order in which they are effected.

To convince himself of this, let the reader place a closed book on its edge on the table before him, and keeping one corner fixed let him give it a right-handed rotation of 90° , first about a vertical axis through this corner, and then about a horizontal axis, and let him note the position to which this brings the book. Then let him replace the book in its original position and repeat the process, changing the order of the rotations. He will find the resulting position to be now quite different, and each is different also from the position which would have been reached by rotation about the diagonal axis.

Hence we cannot deduce the parallelogram of rotational velocities from that of finite rotational displacements as we can that of linear velocities from that of finite linear displacements.

Composition of simultaneous rotational velocities about parallel axes.—The student will easily verify for himself that the resultant of simultaneous rotational velocities ω_α and ω_β about two parallel axes A and B is a rotational velocity equal to $\omega_\alpha + \omega_\beta$ about a parallel axis D which divides the distance between A and B inversely as ω_α and ω_β .

If ω_α and ω_β are equal and opposite (graphically represented by a couple) then the resultant motion of every particle of the rigid body is easily seen to be a translation perpendicular to the plane containing the two axes and equal to the rotational velocity about either multiplied by the distance between them.

A farther extension is now also easy, and the student will realise that just as any system of forces reduces to a single force through some arbitrarily chosen point and a couple, so any system of simultaneous rotational velocities of a rigid body about any axes whatever, whether intersecting or not, reduces to, or is equivalent to, a rotational velocity about an

axis through some arbitrarily chosen point, together with a motion of translation.

(4) PRECESSION OF GYROSCOPE AND SPINNING TOP
WITH AXIS INCLINED.

THE value (ω) of the steady precessional velocity of a gyroscope whose axis is inclined at an angle θ to the vertical, where an external tilting couple of moment L is applied about the axis EF' (see Fig. 91) may be found as follows.

Referring still to Fig. 91, let the vertical axis of precession be called (y) and the axis EF of the couple, (z), and the horizontal axis in the same plane as the axle of spin (x). Let C be the moment of inertia of the disc about the axle of spin, A its moment about a perpendicular axis, and let Ω be the angular velocity of spin *relative to the already moving frame*.

(1) Let the dimensions of the ring have been adjusted in the way mentioned on p. 153 so that the rotation about y introduces no centrifugal couple. Then the value of the angular momentum about (x) is simply $C\Omega \sin \theta$, and to rotate this about (y) with angular velocity (ω) will require a couple (L) about (z) equal to $\omega C\Omega \sin \theta$.

$$\text{Whence } \omega = \frac{L}{C\Omega \sin \theta}.$$

It follows that with a gyroscope so adjusted the rate of steady precession produced by a weight hung on as in Fig. 91 will be the same whether the axis be inclined or horizontal for the length of the arm on which the weight acts, and therefore the couple L , is itself proportional to $\sin \theta$.

N.B.—The resolute of ω about the axis perpendicular to EF and CD is $\frac{L}{C\Omega}$ as before (p. 147).

(2) Let the ring and disc not have the adjustment mentioned, and let the least and greatest moments of inertia of

the ring be C' and A' respectively. If the disc were not spinning in its frame, *i.e.* if Ω were zero, we should require for equilibrium a centripetal couple (see p. 122) equal to $-(A-C)\omega^2 \sin \theta \cos \theta - (A'-C')\omega^2 \sin \theta \cos \theta$. On account of the spin an additional angular momentum $C\Omega \sin \theta$ is added about x , to rotate which requires an additional couple $\omega C\Omega \sin \theta$. Whence the total couple required

$$=L=C\Omega\omega \sin \theta - (A-C-A'-C')\omega^2 \sin \theta \cos \theta,$$

which gives us ω .

In the case of a top precessing in the manner indicated in Fig. 96, the tilting couple is $mgl \sin \theta$, and the only difference in the solution is that there is no frame, so that $A'=0$ and $C'=0$.

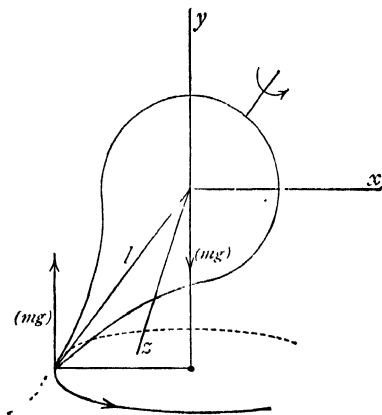

FIG. 97.

But it will be observed that our Ω still means the velocity of spin relative to an imaginary frame swinging round with the top. The quadratic equation for ω thus becomes $mgl = C\Omega\omega - (A-C)\omega^2 \cos \theta$.

We might, if we had preferred it, in each case have simply found by resolution the total angular momentum about (x) after the manner of page 134, and, multiplying this by ω , have obtained the value of the couple about z . But by looking at the matter in the way suggested the student will better realise the fact that the centripetal couple is that part of the applied couple which is required to rotate the angular momentum contributed about x by the precessional rotation itself.

(5) NOTE ON EXAMPLE (4) p. 86.

A VERY simple and beautiful experimental illustration, which is almost exactly equivalent to that indicated in the text, is the following:—

Let a long, fine string be hung from the ceiling, the lower end being at a convenient height to take hold of, and let a bullet or other small heavy object be fastened to the middle of the string. Holding the lower end vertically below the point of suspension let the string be slackened and the bullet caused to rotate in a horizontal circle. On now tightening the string the diameter of this circle will contract and the rate of revolution will increase; on slackening the string the reverse happens [Conservation of Angular Momentum]. The kinetic energy gained by the body during the tightening is equivalent to the work done by the hand + a very small amount of work done by gravity, since the smaller circle is in a rather lower plane than the larger.

(6) ON THE CONNEXION BETWEEN THE CENTRIPETAL COUPLE AND THE RESIDUAL ANGULAR MOMENTUM.

It is convenient to think of the centripetal *force* which acts on any uniformly rotating particle of mass m (see fig. 97) as the force which is required to rotate the momentum (mv) of the particle at the required rate. The force $= mrv = mrv \times \omega = mv \times \omega$, *i.e.* the centripetal force = the momentum to be rotated \times rate of rotation.

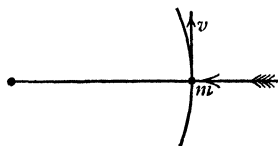

FIG. 98.

Now consider a simple rigid system consisting of two particles of mass m and m' connected by a mass-less rigid rod, and let this be rotating

with angular velocity ω about a fixed axle Oy passing through the centre of mass O . Take Ox in the plane of the paper as the axis of x , and the axis Oz perpendicular to the plane of the paper. First let the rod be perpendicular to Oy . Oy is then a principal axis. There is no angular momentum about any line in the plane xz , and no centripetal couple. Next let

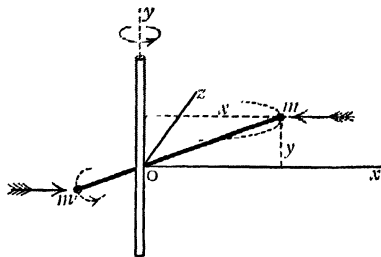

FIG. 99.

the rod be inclined as shown, and let it be passing through the plane xy . Oy is no longer a principal axis, and there is now a centripetal couple (of moment $ymx\omega^2 + y'm'x'\omega^2 = \omega^2 \Sigma mxy$) and also angular momentum about Ox (the value of which is $ymx\omega + y'm'x'\omega = \omega \Sigma mxy$). At the instant in question there is no angular momentum about Oz , for each particle is moving parallel to Oz , but after a quarter-turn the amount of angular momentum at present existing about Ox will be found about Oz . Thus the total residual angular momentum is rotated by the centripetal couple whose value is equal to the residual angular momentum rotated \times the rate of rotation.

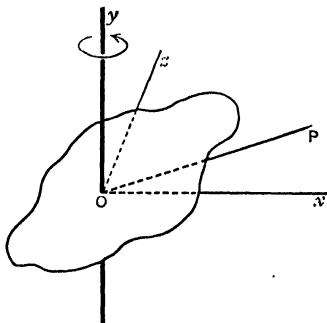

FIG. 100.

It should be observed that during the quarter-turn from x to z , the centripetal couple will also gradually destroy the angular momentum previously existing about Oz .

The same is true even in the most general case of a body

of three unequal moments of inertia, rotating about any non-principal axis, Oy , through the centre of mass O . For the residual angular momentum ($\omega_y \sum mxy$) about Ox , when combined by the parallelogram law with that about Oz (equal to $\omega_y \sum mzy$) will give a total residual angular momentum about some line OP in the plane xz . The centripetal couple is in the plane yOP , and equal to the angular momentum about $OP \times$ the rate of rotation.

Explanation of the criterion for centre of Percussion:—

The reader will now be better able to realise the significance of the criterion for the existence of a centre of percussion given on p. 129.

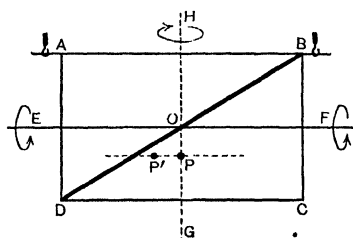

FIG. 101.

Let him think of a uniform, rectangular, thin board ABCD swinging freely about a fixed axle AB along its upper horizontal edge, and loaded with a uniform massive diagonal bar BD. We wish to find if, and where,

the front of the board can be struck, so as to give no impulsive shock to the axle, and we have already learnt that the blow must be struck at right angles to the board, and so that the board, if free, would begin to rotate about EOF drawn through the centre of mass O parallel to the axle AB . Further we know that both for board and rod separately, and therefore for the two together, the blow must be delivered at a distance $\frac{2}{3}$ of BC from the fixed axle.

But where the bar rotates about EF , it will have left-handed angular momentum about GH also, and if we struck our blow at P on HG , we could not impart any such angular momentum, which therefore could only be derived from an impulsive pressure of the axle forward at B and backward

at A. If, however, we shift P to the left, to some point P', keeping it always at the same distance from AB, we can give the angular momentum required about GH. The axle will then experience no strain, and it is easy, when the masses of board and rod are known, to calculate the shift required which fixes the position of the centre of pressure.

In this case every particle of the system, when rotation begins, moves perpendicularly to the paper, and there is no angular momentum about an axis through O at right angles to the paper. But if the bar, still centred at O, were inclined to the board at any angle (other than 90°), there would be suddenly acquired angular momentum also about an axis through O, parallel to the blow, which could not be imparted by the blow, but only by impulsive pressures up and down at A and B. Hence in this case there would be no centre of percussion.

Thus the criterion is that with rotation about EOF, the axis of *total* residual angular momentum shall be HG, *i.e.* shall be *in the plane containing the fixed axle and the centre of mass*, and therefore, as we have seen, the centrifugal couple must lie in this plane, and this is the form in which the criterion was given—not because the centrifugal forces come into play, but because it is generally easier from inspection to form a fairly accurate impression of the position of the plane of the centrifugal couple than it is to realise the direction of the residual angular momentum.

INDEX

- ACCELERATION of centre of mass, 101, 104.
 — linear, 3.
 — of particle moving round a circle, 111.
 Acceleration (angular or rotational), 3, 12.
 — of centre of mass, 104.
 — composition of, 7.
 — geometrical representation of, 6.
 — mass, 30, 102.
 — proportional to torque, 12, 30.
 — ratio of, to displacement in simple harmonic motion, 73.
 — relation of, with torque and rotational inertia, 17.
 — uniform, 3.
 — variation of, with distribution of matter, 17.
 Angle, unit of, 2.
 Annulus (plane circular), radius of gyration of, 54 (4).
 Area, moment of, 7.
 — moment of inertia of, 33.
 — radius of gyration of, 37, 38.
 Artifice (dynamical), for questions involving centripetal force, 116.
 Atwood's machine, 43 (8).
 Axes, of greatest and least moment of inertia, 56.
 — principal, 57, 132.
 — theorem of parallel, 37.
 Axis, 9.
 — about which a couple causes a free rigid body to rotate, 96, 105.
 — instantaneous, 135.
 — invariable, 135.
 Axle, 9, 137.
 Axle, pressure on, 126, 129.
 — of spin, 137.
 BAR, *see* Rod.
 Bat (cricket), centre of percussion of, 128.
 Bicycle, 143.
 Boat (sailing), a rigid body, 1.
 Body (rigid), 1.
 — centre of gravity of, 37.
 — centre of percussion in, 128.
 — centrifugal couple in, 118.
 — centripetal force in, 113.
 — effect of couple on, 96, 105, 106.
 — equimomental, 64, 121.
 — modulus of elasticity of, 73.
 — motion of, with one point fixed, 2, 6.
 — point of, having peculiar dynamical relations, 94-98.
 — spinning, 136-158; *see also* Gyroscope and Top.
 — total kinetic energy of, 107.
 Brake (friction), 15.
 CARRIAGE, effective inertia of, 45 (16).
 Centre (of gravity), 37, 96, 97 (footnote).
 Centre (of inertia), 38 (footnote).
 Centre (of mass), 38 (footnote), 94-110, 99.
 — acceleration of, 101, 104.
 — displacement of, 100.
 — velocity of, 101.
 Centre (of percussion), 125-129, 126.
 — criterion for, 129, 168.
 Compass needle, moment of inertia of, 34.

- Couple, change of kinetic energy due to, 24.
 — effect of, on free rigid body, 96, 105, 106.
 — on spinning body, 139.
 — restoring, 75.
 — unit, 9.
 — work done by, 23.
- Couple (centrifugal), 117-120.
 — effect of, on peg-top, 154.
 — of equimomental bodies, 121.
 — transfer of energy under action of, 123.
- Couple (centripetal), 133.
 — connection of, and residual angular momentum, 166.
 — elimination of, in gyroscope, 153.
- Curve, precessional force due to wheels of railway engine rounding a, 157.
- Curves (inertia), graphical construction for, 60-64, 66.
- Cylinder (thin hollow), radius of gyration of, 25.
- D'ALEMBERT'S PRINCIPLE**, 30.
- Deformation, proportional to force, 70.
 — unit of, 70.
- Disc, moment of inertia of, 39, 50.
 — kinetic energy of rolling, 110 (1).
- Displacement of centre of mass, 100.
 — ratio of acceleration to, in simple harmonic motion, 73.
- Door, 15, 42 (2) and (7).
 — centre of percussion of, 128.
 — moment of inertia of, 39.
- EARTH**, rotation of, 88.
- Effort to precess, calculation of, 156.
- Elasticity, modulus of, 73 (foot-note).
 — perfect or simple, 70.
- Ellipse, moment of inertia of, 51.
- Ellipsoid, moment of inertia of, 53.
- Energy, transfer of, under action of centrifugal couple, 123.
- Energy (kinetic), change of, due to couple, 24.
 — due to variation of the moment of inertia, 87, 166.
 — of precessing spinning body, 147.
 — of rolling disc, 110 (1).
 — of rolling hoop, 110 (2).
 — of rolling sphere, 110 (3).
 — total, of rigid body, 107.
- Engine (railway), precessional force due to wheels of, on a curve, 157.
- Examples, on angular oscillations, 76-78.
 — on angular velocity, 3.
 — on conservation of angular momentum, 83-86, 87.
 — on effort to precess, 157.
 — on equivalent simple pendulum, 77, 78.
 — on properties of centre of mass, 108, 109.
 — on radius of gyration, 53.
 — on rotational inertia, 18, 25-30.
 — on simple harmonic motion, 74.
 — for solution, 42-45, 53, 54, 81, 93, 110, 159.
 — on turning of ship, 158.
 — on uniform angular acceleration, 5, 6.
- Experiments, on behaviour of spinning bodies, 137, 138, 142.
 — on centre of percussion, 126.
 — on equality of torque, 8.
 — on existence of rotational inertia, 16.
 — on floating magnet, 97.
 — on Hooke's Law, 70, 71.
 — on point of a body having peculiar dynamical relations, 94-98.

- Experiments on precession, 139-141.
 — on proportionality of torque and angular acceleration, 13, 14.
 — on value of rotational inertia, 18.
- FIGURE (solid), moment of inertia of, 33, 60.
- Flywheel (with light spokes and thin rim), radius of gyration of, 25.
- Foot-pound, 22 (footnote).
 Foot-poundal, 9, 22 (footnote).
 Force, centrifugal, 111-124.
 — centripetal, 111-124, 112, 113.
 — connection between centrifugal and centripetal, 112.
 — elastic, 73.
 — moment of, 7, 8.
 — precessional, due to wheels of railway engine rounding a curve, 157.
 — turning power of, 7.
- Fork (tuning), motion of, 63.
- Friction, 11.
 — brake, to check rotation, 15.
 — entirely removed, 11.
 — moment of, 11.
 — pivot, effect on gyroscope, 153.
- GRAVITY (centre of), *see* Centre (of gravity).
 Gyration (radius of), *see* Radius (of gyration).
 Gyroscope, 136.
 — with axle of spin inclined, 152, 164.
- HOOKE'S LAW, 70.
- Hoop, equivalent simple pendulum of, 77.
 — experiments with, 141, 142.
 — kinetic energy of rolling, 110 (2).
 — moment of inertia of thin, 35.
 — precession of, 141.
- Hoop, radius of gyration of thin, 25.
- IDEAL single particle system, 19.
- Inertia, 16.
 — the cause of wobble of spinning body, 148.
 — curves, graphical construction for, 60, 64, 66.
 — effective, of a carriage, 45 (16).
 — skeleton, 64, 121.
 — surfaces, 60-64, 66.
- Inertia (rotational), 17, 19, 30.
 — calculation of, of rigid body, 18.
 — relation of, with torque and angular acceleration, 17.
 — unit of, 17.
- Inertia (moment of), 7, 20, 34.
 — about any axis, 38, 58.
 — of area, 33, 48.
 — axes of greatest and least, 56.
 — calculation of, 46.
 — of compass needle, 35.
 — of disc, 39, 48, 50.
 — of door, 39.
 — effect of change of, on kinetic energy, 87, 166.
 — of ellipse, 51.
 — of ellipsoid, 53.
 — general case for, of solid, 60.
 — of hoop, 35.
 — of lamina, 35, 54, 58.
 — maximum and minimum, 56.
 — of a model compared to that of real object, 45 (15).
 — of a peg-top, 34.
 — principal, 57.
 — of prism, 34, 40.
 — by oscillating table, 79.
 — of rod, 37, 40, 46, 50.
 — Routh's rule for, 36.
 — skeleton, 64, 121.
 — of solid figure, 33.
 — of sphere, 37, 52.
 — sum of, of rigid body about three rectangular axes, 55
 — surface, 63.

- Inertia (moment of), unit, 20.
— of wheel and axle, 44 (10).
- JUGGLER (spinning), 87.
- LAMINA, centrifugal force in rigid, 113.
— inertia curve for, 61.
— moment of inertia of, 35, 54, 58.
- Lath, bending of, 70, 71.
— time of oscillation of, 75.
- Law (Hooke's), 70.
- Laws of Motion (Newton's), 10.
— analogues in rotation to, 11, 12, 18, 82.
- Lb., distinction of, with pound, 9.
Lb.-foot², 21.
- MACHINERY, importance of proper shape for rapidly revolving, 121.
— pitching and rolling effect on, of ship, 157.
- Magnet, oscillating, 41, 77, 78.
— floating, 96.
- Mass, acceleration, 102.
— analogue of, in rotational motion, 25.
— centre of, *see* Centre (of mass).
— displacement, 102.
— moment of, 7.
— proportional to weight, 38 (footnote).
— unit of, 9 (footnote).
- Model, moment of inertia of, compared to real object, 45 (15).
- Moment of area, 7.
— of friction, 11.
— of force, 7, 8.
— of inertia, *see* Inertia (moment of).
— of mass, 7.
— of mass displacement of particles, 102.
— of momentum, 89.
- Momentum (angular), 21.
— about principal axes, 134 (footnote).
- Momentum, connection of residual, with centripetal couple, 166.
— conservation of, 82.
— graphical representation of, 88.
— moment of, 89.
— of system of particles, 103.
— total, 130-135, 133.
- Motion, Laws of, *see* Laws of Motion (Newton's).
— precessional, 138.
— round a fixed axle, 83.
— simple harmonic, 67-69, 73.
— of tuning fork, 68.
- NEEDLE (compass), moment of inertia of, 34.
Newton's Laws of Motion, *see* Laws of Motion (Newton's).
- OSCILLATION, angular, 75.
— of cylindrical bar magnet, 41.
— elastic, 70-81.
— of heavy spiral spring, 75.
- PARALLELOGRAM of rotational velocities, 6, 161.
— of rotational accelerations, 7, 162.
- Peg-top, *see* Top.
- Pendulum, ballistic, 91, 93 (5).
— equivalent simple, 76.
— simple, 76.
- Percussion (centre of), *see* Centre (of percussion).
- Period of simple harmonic motion, 68.
- Phase of simple harmonic motion, 69.
- Plane (principal), 57.
- Planets, rotation of, 88.
- Pound, distinction of, with lb., 9.
— -foot, 9.
— two senses of word, 9.
- Poundal, 9.
— -foot, 9.
- Power (turning), *see* Torque.
- Precession, 139, 164.

