

UNIVERSAL
LIBRARY

OU_164566

UNIVERSAL
LIBRARY

OSMANIA UNIVERSITY LIBRARY

Call No. *545.9/00 H O* Accession No. *29857*

Author

Title *Organic Synthesis v. 2*

This book should be returned on or before the date last marked below.

ORGANIC SYNTHESSES

THESE VOLUMES NOW READY

Volume I.

ROGER ADAMS, University of Illinois, Editor-in-Chief. vi+84 pages, 6 by 9; 7 figures Cloth.

Volume II.

JAMES BRYANT CONANT, Harvard University, Editor-in-Chief. vii+100 pages, 6 by 9; 3 figures. Cloth.

Volume III.

HANS TRACHER CLARKE, Eastman Kodak Company, Editor-in-Chief. 4+105 pages, 6 by 9; 3 figures Cloth

Volume IV.

OLIVER KAMM, Parke, Davis, and Company, Editor-in-Chief. v+89 pages, 6 by 9; 3 figures Cloth.

Volume V.

CARL SHIPP MARVEL, University of Illinois, Editor-in-Chief. 4+110 pages, 6 by 9, 3 figures. Cloth.

Volume VI.

HENRY GILMAN, Iowa State College, Editor-in-Chief v+120 pages; 6 by 9; 5 figures. Cloth.

Volume VII.

FRANK C. WHITMORE, Northwestern University, Editor-in-Chief. vii+105 pages; 6 by 9, 1 figure. Cloth.

Volume VIII.

ROGER ADAMS, University of Illinois, Editor-in-Chief. v+139 pages; 6 by 9, 3 figures. Cloth.

ORGANIC SYNTHESSES

AN ANNUAL PUBLICATION OF SATISFACTORY
METHODS FOR THE PREPARATION
OF ORGANIC CHEMICALS

EDITORIAL BOARD

JAMES BRYANT CONANT, *Editor-in-Chief*
HANS THACHER CLARKE

ROGER ADAMS
OLIVER KAMM

CONTRIBUTORS

G. H. COLEMAN
J. C. HESSLER
E. P. KOHLER
C. S. MARVEL

W. A. NOYES
G. R. ROBERTSON
E. B. VLIET
F. C. WHITMORE

VOL. II.

NEW YORK
JOHN WILEY & SONS, Inc.
LONDON: CHAPMAN & HALL, LIMITED

Copyright, 1922
BY
ROGER ADAMS

Printed in U. S. A.

PRESS OF
BRAUNWORTH & CO., INC.,
BOOK MANUFACTURERS
BROOKLYN, NEW YORK

INTRODUCTION TO THE SERIES

THE publication of this series of pamphlets has been undertaken to make available in a permanent form complete detailed directions for the preparation of various organic chemical reagents. In announcing this purpose it may be well to mention at the outset some of the difficulties in the way of the research chemist, which it is hoped this series will be able to overcome. The cost of chemicals is prohibitive to the majority of chemists; this was true before the war when Kahlbaum's complete supply was available, and to-day with our dependence on domestic stocks, this cost has increased. The delay in obtaining chemicals, especially from abroad, even if the expense need not be considered, is an important factor. These difficulties have therefore thrown the research chemist on his own resources. The preparation of materials for research, always time consuming and annoying, is made increasingly so by the inexactness of the published information which so often omits essential details. Because of this, much needless experimentation is necessary in order to obtain the results given in the published reports. As the additional information thus acquired is seldom published, duplication of such experiments occurs again and again,—a waste of time and material. It is hoped these difficulties may be remedied by the publication of this series of pamphlets. In other words, the authors hope to make this a clearing house for the exchange of information as to methods of preparation of some of the most needed organic chemical reagents.

On account of the impossibility of obtaining the less common organic chemicals in the United States during the past few years,

university laboratories have had no option but to prepare their own supplies. At the University of Illinois, for instance, a special study has been made of this field, and methods for the production of various substances have been investigated. As a result, reliable methods and directions have been developed for producing the materials in one-half to five pound lots. Such work as Illinois has done is now being given an even more extensive scope at the Research Laboratory of the Eastman Kodak Company. It is felt that the results from these various laboratories should be available to all chemists and it is hoped that they eventually will be completely incorporated in these pamphlets.

The organic chemicals herein discussed have been quite arbitrarily chosen, being those which have been needed in various research laboratories in the last years and for which the directions happen now to be ready for publication. The methods are in only a few cases new ones; they are in general the most satisfactory to be found in the literature. Only such details have been added as will enable a man with a reasonable amount of experience in organic chemistry to duplicate the results without difficulty. To be absolutely sure that each set of directions can be repeated, every experiment has been carried out in at least two laboratories. Only after exact duplication of the results in both laboratories are the directions considered ready for publication. The names of the chemists who have studied the various experiments are given so that further information concerning any obscure point can be obtained if any question arises in using these directions. And finally, in describing the experiments, special attention has been given to the explanation of why it is necessary to follow the directions carefully, and what will happen if these directions are not followed.

Although the main object in this series is to give the most convenient laboratory methods for preparing various substances in one-half to five pound lots, an attempt has also been made to have these processes as far as possible adaptable to large scale development. For example, extractions have been avoided wherever possible, cheap solvents have been sub-

stituted for expensive ones, and mechanical agitation, a procedure extremely important in the success of many commercial processes, has usually been specified. The apparatus used is always carefully described and wherever necessary an illustration is given. Accompanying each preparation there will be found a bibliography containing references to all the methods for the production of the substance described in the literature. This is given in order to aid any future investigator who may wish to study or improve the methods of preparation. It is not claimed that the methods are, in every case, completely perfect, but only that the yields are very satisfactory and allow the production of the substances at a reasonable cost. It is hoped therefore that the pamphlets will benefit not only the scientific research man of the university, but also the technical chemist who desires to develop the preparation of one of these substances to a large scale process of manufacture. The editors trust also that this work may be used to advantage as a preparation manual in intermediate or advanced courses in organic chemistry in university laboratories, and that it will aid small colleges in the production of necessary reagents which they are often financially unable to purchase.

The pamphlets are to be edited by the following committee: Roger Adams, University of Illinois, Urbana, Illinois; J. B. Conant, Harvard University, Cambridge, Massachusetts; H. T. Clarke, Eastman Kodak Company, Rochester, New York; Oliver Kamm, Parke, Davis Company, Detroit, Michigan; each to act for one year as editor-in-chief and the other three to assist him as associate editors. A new number of the series will appear annually, and every ten years the data will be rearranged, revised, corrected, and then published in book form. The number of preparations to be completed yearly is not fixed. There will be, it is certain, about twenty; and it is hoped, as the interest is stimulated in this work, that this number may increase considerably. The editors especially desire to solicit contributions from other chemists, not only in this country but abroad. Whenever a compound is thoroughly and extensively studied in connection with some research, it is hoped that

complete directions for its preparation will be assembled and sent to the editor. He will then have them checked and published in a subsequent number. Directions for the preparation of substances already on the market are needed to make this work complete and will be gladly accepted.

It will, of course, be recognized that an occasional mistake or omission will inevitably be found in such a pamphlet as this which contains so many references and formulæ. The committee on publication will therefore deem it a favor if they are notified when any such error is discovered. It is hoped also that if any chemist knows a better method for the preparation of any of the compounds considered, or if anyone discovers any improvements in the methods, he will furnish the authors with such information. Any points which may arise in regard to the various preparations will be gladly discussed. In conclusion, the editors are ready to do all they can to make this work successful, and welcome suggestions of any kind. They feel that the success of the series will undoubtedly depend upon the cooperation of others, and as its success promises to be important to research chemists, the editors urge all interested to assist.

THE EDITORS

TABLE OF CONTENTS

	PAGE
I. BENZALACETOPHENONE	1
II. BENZYL BENZOATE	5
III. BENZYL CYANIDE	9
IV. α , γ -DICHLOROACETONE	13
V. <i>p</i> -DIMETHYLAMINO BENZALDEHYDE	17
VI. ETHYL OXALATE	23
VII. ETHYL PHENYLACETATE	27
VIII. GLYCEROL α , γ -DICHLOROHYDRIN	29
IX. GLYCEROL α -MONOCHLOROHYDRIN	33
X. HYDRAZINE SULFATE	37
XI. MESITYLENE	41
XII. METHYL RED	47
XIII. <i>p</i> -NITROBENZOIC ACID	53
XIV. <i>p</i> -NITROBENZYL CYANIDE	57
XV. <i>p</i> -NITROPHENYLACETIC ACID	59
XVI. NITROSO- β -NAPHTHOL	61
XVII. PHENYLACETIC ACID	63
XVIII. PHENYLACETYLENE	67
XIX. PHENYLHYDRAZINE	71
XX. PHTHALIMIDE	75
XXI. QUINOLINE	79
XXII. QUINONE	85
XXIII. SODIUM <i>p</i> -TOLUENESULFINATE	89
XXIV. 1, 3, 5-TRINITROBENZENE	93
XXV. 2, 4, 6-TRINITROBENZOIC ACID	95
INDEX	99

ORGANIC SYNTHESSES

I

BENZALACETOPHENONE

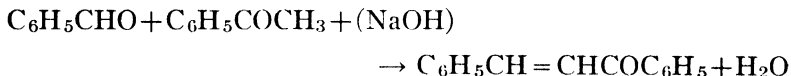

Prepared by E. P. KOHLER and H. M. CHADWELL.
Checked by H. T. CLARKE and R. P. LEAVITT.

1. Procedure

A SOLUTION of 218 g. of sodium hydroxide in 1960 g. of water and 1000 g. of 95 per cent alcohol are introduced into a 5500-cc. bottle which is loosely covered with a perforated disk of cardboard, supplied with an effective stirrer, and supported in a larger vessel so as to permit cooling with cracked ice. Into the alkaline solution, 520 g. of pure acetophenone is poured, the bottle is rapidly surrounded with cracked ice, and the stirrer started; 460 g. of benzaldehyde (U. S. P.) are then added at once. The temperature of the mixture should not be below 15° and it should not be allowed to rise above 30° during the reaction. If it tends to do so, the stirring is not sufficiently vigorous.

It is advantageous, though not essential, to inoculate the mixture with a little powdered benzalacetophenone after stirring for half an hour. After two to three hours, the mixture becomes so thick that the stirring is no longer effective. The stirrer is then removed and the mixture left to itself in an ice-box for about ten hours. The mixture now is a thick paste composed of

small shot-like grains suspended in an almost colorless liquid. It is cooled in a freezing mixture and then either centrifuged or filtered on a large Buchner funnel, washed with water until the washings are neutral to litmus, and finally washed with 200 cc. of alcohol, which has previously been cooled to 0° . After thorough drying in the air, the crude product weighs about 880 g. (yield 97 per cent of the theoretical amount) and melts at $50-54^{\circ}$. It is sufficiently pure for most purposes but tenaciously holds traces of water. It is most readily purified by recrystallization from four to four and a half times its weight of 95 per cent alcohol. Eight hundred and eighty grams of crude product give 770 g. (85 per cent of the theoretical amount) of light-yellow material (m. p. $55-57^{\circ}$) and 40-50 g. that require recrystallization.

2. Notes

The acetophenone should be as pure as possible (m. p. 20°). Commercial acetophenone contains variable quantities of impurities which reduce the yield. By distilling commercial acetophenone with the help of a good still-head (preferably under diminished pressure) and using only the fraction which boils at $201-202^{\circ}$ ($76-77^{\circ}/10$ mm.) greater quantities of benzalacetophenone can be obtained than by using the entire sample.

Commercial benzaldehyde can be used in place of the purer product, but the amount used must be increased to make up for the impurities which are present.

If the temperature is too low, or the stirring too slow, the product separates as an oil, which later solidifies in large lumps.

If the temperature is allowed to rise above 30° , secondary reactions diminish both the yield and the purity of the product. The most favorable temperature is 25° .

In recrystallizing benzalacetophenone, the alcohol should be saturated at 50° . If the solution is saturated above this temperature, the benzalacetophenone tends to separate as an oil. The solution should be allowed to cool gradually, and should finally be chilled in a freezing mixture.

3. Other Methods of Preparation

The methods for producing benzalacetophenone are: the action of acids on a mixture of benzaldehyde and acetophenone or on a solution of these substances in glacial acetic acid;¹ the condensation of benzaldehyde and acetophenone with a 30 per cent solution of sodium methylate at low temperatures;² the action of sodium hydroxide on an alcoholic solution of benzaldehyde and acetophenone.³

The methods based on the use of acids as condensing agents were not considered, because Claisen, who devised them, abandoned them after he found that alkaline condensing agents gave better results. The preliminary experiments showed that condensation with sodium methylate takes a long time and gives a product which it is difficult to handle in large quantities. The method devised by Kostanecki and Rossbach³ has therefore been developed.

¹ Ber. **14**, 2463 (1881).

² Ber. **20**, 657 (1887).

³ Ber. **29**, 1492 (1896).

II

BENZYL BENZOATE

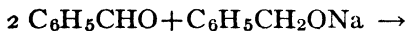

Prepared by O. KAMM and W. F. KAMM.

Checked by ROGER ADAMS and R. L. JENKINS.

1. Procedure

THREE grams of metallic sodium are dissolved by warming for half an hour in 70 g. of pure benzyl alcohol (see notes), and after the mixture has cooled to room temperature the solution is added gradually, with thorough mixing, to 454 g. of c. p. benzaldehyde (which must contain *less* than 1 per cent of benzoic acid). The reaction mixture has a tendency to become warm, but the temperature should be kept slightly below 50–60° by cooling, if necessary. A pasty gelatinous mass results. After about half an hour the temperature of the mixture no longer rises; it is then warmed on the water bath for about one or two hours, with occasional shaking.

The cooled reaction product is treated with 200 cc. of water, the layer of oil separated, washed once with a second portion of water, and subjected to distillation *in vacuo*. The first fraction of the distillate contains benzyl alcohol together with unchanged aldehyde, as well as a small quantity of water. The temperature then rises rapidly to the boiling-point of benzyl benzoate, when the receivers are changed. The product boils at 184–185°/15 mm., and analysis by saponification shows it to consist of 99 per cent ester. A yield of 410–420 g. is obtained, which corresponds to 90–93 per cent of the theoretical amount. This benzyl benzoate supercools readily, but after solidifying

melts within one degree of the highest recorded value (19.4°) and therefore need not be refractionated, unless material of exceptional grade is required.

2. Notes

In the presence of sodium benzylate two molecules of benzaldehyde react with the alcoholate to form an addition product. When the reaction mixture is overheated an important side reaction may occur, as follows:

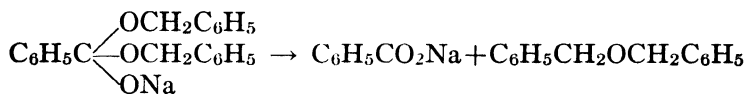

Dibenzyl ether no doubt forms the chief impurity in benzyl benzoate. Since the boiling-point of the former lies near that of the ester, it is not removed during the process of purification by distillation.

The causes of variations in yield by the use of the older methods can now be explained. When benzaldehyde is added to the alcoholate, and especially when the latter is still warm, local overheating results; in fact, the temperature may rise far above 100° with the result that benzyl ether is formed. Simultaneously, the sodium benzylate is converted into sodium benzoate, which is of no value for inducing the desired reaction, and consequently very little benzyl benzoate is obtained. The same side reactions explain the failure of this experiment when the benzyl alcohol used in preparing the catalyst (sodium benzylate) is contaminated with benzaldehyde.

The benzyl alcohol used in this preparation must be free from impurities, especially aldehyde. One cc. dissolved in 50 cc. of water and treated with a freshly prepared clear solution of phenylhydrazine acetate should give no appreciable precipitate. If it is not pure, it must first be treated with alkali as described below.

The benzaldehyde should be titrated in order to determine its acidity. If it is found to contain sufficient benzoic acid to react with a considerable proportion of the sodium alcoholate,

a poor yield of ester will be obtained. Less than 1 per cent of benzoic acid will not interfere seriously with the yields obtained, but the presence of larger quantities of acid will be found to be detrimental and must be removed by washing the benzaldehyde with a sodium carbonate solution and redistilling with the precautions necessary to prevent too free an access of air to the distillate.

The order of mixing the reagents and the temperature of the ingredients at the time of mixing are the most important factors in the experiment. The temperature at which the reaction mixture is maintained after mixing, provided that it is held below 100° , is less important from the standpoint of purity.

The reaction mixture is not treated with acetic acid, as usually recommended, for the reason that such a procedure yields a final product contaminated with benzoic acid, unless an alkaline wash is applied subsequently.

The recovered benzyl alcohol can be used for the preparation of a second lot of benzyl benzoate only after it has been boiled with strong sodium hydroxide to remove all traces of benzaldehyde.

3. Other Methods of Preparation

Benzyl benzoate has been identified in certain natural plant products.¹ In the laboratory it has been prepared by the action of (a) benzoyl chloride upon benzyl alcohol,² (b) benzyl chloride upon sodium benzoate, and (c) alcoholates upon benzaldehyde.³ Recently, Gomberg and Buchler⁴ have shown that reaction (b) may be conducted even with aqueous solutions of sodium benzoate.

The Claisen method (c) furnishes the most convenient and practical procedure for the preparation of this ester. The materials are cheap, the experimental procedure simple, and the product obtained is free from objectionable traces of benzyl

¹ Ann. **152**, 131 (1869).

² Gmelin's Handbuch der Organ. Chem. **3**, 40.

³ Ber. **20**, 649 (1887). Cf. also J. Chem. Soc. **75**, 1155 (1899).

⁴ J. Am. Chem. Soc. **42**, 2059 (1920).

chloride. Unfortunately, the method has been found to be extremely erratic in regard to yield (10-95 per cent), as well as in regard to purity of the product (87-97 per cent ester).¹ As a result of the present study,² causes for variations are fully accounted for and the procedure has been converted into a satisfactory method of preparation.

¹ C. A. **14**, 3500 (1920).

² J Am Pharm Assoc. **11**, 599 (1922).

III

BENZYL CYANIDE

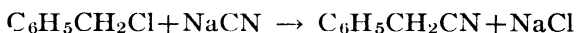

Prepared by ROGER ADAMS and A. F. THAL.
Checked by O. KAMM and A. O. MATTHEWS.

1. Procedure

IN a 5-l. round-bottom flask, fitted with a stopper holding a reflux condenser and separatory funnel, are placed 500 g. of powdered sodium cyanide (96-98 per cent pure) and 450 cc. of water. The mixture is warmed on a water bath in order to dissolve most of the sodium cyanide, and then 1 kg. of benzyl chloride (b. p. 170-180°) mixed with 1 kg. of alcohol is run in through the separatory funnel in the course of one-half to three-quarters of an hour. The mixture is then heated with a reflux condenser on the steam bath for four hours, cooled and filtered with suction to remove most of the sodium chloride. It is well to wash the filtered salt with a small portion of alcohol in order to remove any benzyl cyanide which may have been mechanically held. The flask is now fitted with a condenser, and as much alcohol as possible is distilled off on the steam bath. The residual liquid is cooled, filtered if necessary, and the layer of benzyl cyanide separated. This crude benzyl cyanide is now placed in a Claisen distilling flask and distilled *in vacuo*, the water and alcohol coming over first, and finally the cyanide. It is advantageous to use a fractionating column or, better still, a Claisen flask with a modified side-arm¹ (Vol. 1, p. 40, Fig. 3) which gives the same effect as a fractionating column. The material is collected from 135-140°/38 mm. (115-120°/10 mm.). The yield is 740-830 g. (80-90 per cent of the theoretical amount).

¹ J. Am. Chem. Soc. **39**, 2718 (1917).

2. Notes

The quality of the benzyl chloride markedly affects the yield of pure benzyl cyanide. If a poor technical grade is used, the yields will not be more than 60-75 per cent of the theoretical, whereas consistent results of about 85 per cent or more were always obtained when a product was used that boiled over 10°. The technical benzyl chloride at hand yielded on distillation about 8 per cent of high-boiling material; a technical grade from another source was of unusual purity and boiled over a 2° range for the most part.

It is advisable to distil off the last portion of alcohol and water *in vacuo* and also to distil the benzyl cyanide *in vacuo*, since under ordinary pressures a white solid invariably separates during the distillation.

One method of purifying the benzyl cyanide is to steam distil it after the alcohol has been first distilled from the reaction mixture. At ordinary pressures, this steam distillation is very slow and, with an ordinary condenser, requires eighteen to twenty hours in order to remove all of the volatile product from a run of 500 g. of benzyl chloride. The distillate separates into two layers; the benzyl cyanide layer is removed and distilled. The product obtained in this way is very pure and contains no tarry material, and, after the excess of benzyl chloride has been removed, boils practically constant. This steam distillation is hardly advisable in the laboratory.

The benzyl cyanide, prepared according to the procedure as outlined, is collected over a 5° range. It varies in appearance from a colorless to a straw-colored liquid and often develops appreciable color upon standing. For a product of special purity, it should be redistilled under diminished pressure and collected over a 1-2° range. For most purposes, such as the preparation of phenylacetic acid or ester, the fraction boiling 135-140°/38 mm. is perfectly satisfactory.

3. Other Methods of Preparation

Benzyl cyanide occurs naturally in certain oils.¹ The only feasible method of preparing it that has been described in the literature is the one in which alcoholic potassium cyanide and benzyl chloride² are employed. The cheaper sodium cyanide is just as satisfactory as the potassium cyanide and therefore is the best material to use. Gomberg has recently prepared benzyl cyanide from benzyl chloride and an aqueous solution of sodium cyanide.³

¹ Ber. **7**, 519, 1293 (1874); **32**, 2337 (1899).

² Ann. **96**, 247 (1855); Ber. **3**, 198 (1870); **14**, 1645 (1881); **19**, 1950 (1886).

³ J. Am. Chem. Soc. **42**, 2059 (1920).

IV

α , γ -DICHLOROACETONE

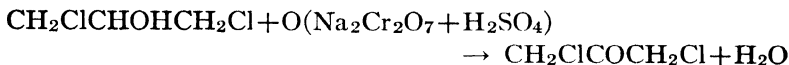

Prepared by J. B. CONANT and O. R. QUAYLE.

Checked by A. W. DOX, L. YODER, and O. KAMM.

1. Procedure

IN a 2-l. flask are placed 375 g. of commercial sodium dichromate, 225 cc. of water, and 300 g. of dichlorohydrin (b. p. 68–75°/14 mm.). The flask is set in a water bath and equipped with a thermometer and mechanical stirrer. The contents are vigorously stirred, and 450 g. of sulfuric acid, diluted with 115 g. of water, are introduced during the course of seven to eight hours. It is convenient to add the acid at ten-minute intervals. The temperature is kept between 20° and 25° during the entire reaction; this is accomplished by adding a little ice to the water bath from time to time. The stirring is continued for sixteen to seventeen hours after all the acid has been added; as there is very little heat evolved during this part of the reaction, the water bath may be allowed to come to room temperature.

Sufficient water is now added to the mixture to dissolve the pasty chromium salts (300–800 cc.). The mass of crystals is then rapidly filtered on a Buchner funnel and sucked as dry as possible. The crystals are then transferred to a small laboratory centrifuge and centrifuged for several minutes. The crystals are washed in the centrifuge with about 15–25 cc. of ice water, then with 10–15 cc. of cold petroleum ether, and finally centrifuged till as dry as possible. The crude dichloroacetone is dried in a vacuum desiccator over sulfuric acid overnight. It weighs about 220 g.

The crude product is best purified by distillation from a 250-cc. distilling flask fitted with an air condenser. A very small fraction (10-15 g.) of low-boiling material is obtained, and the dichloroacetone (170-175°) is then collected. It solidifies in the receiver to a white crystalline mass which weighs 200-220 g. (65-70 per cent of the theoretical amount). A few grams more may be obtained by chilling the low-boiling fraction and filtering off the water.

2. Notes

Great caution should be exercised in working with dichloroacetone, as it is extremely lachrymatory and blisters the skin.

In transferring the crystals from the reaction flask to the Buchner funnel it is necessary to use a certain amount of water to dissolve the pasty chromium salts which are otherwise quite impossible to filter. The amount necessary varies greatly in different runs, according to the manner in which the chromium salts separate. The amount of this water is kept low in order to dissolve as little of the product as possible. Nevertheless, 10-15 g. of dichloroacetone are thus dissolved; this material, together with a little unchanged dichlorohydrin, may be recovered by a long procedure involving extraction with ether and sodium bisulfite. This is not profitable, however.

It is not necessary to wash the crystals in the centrifuge until they are white. A small amount of chromic salt will not interfere with the subsequent purification.

Commercial sodium dichromate is hygroscopic and contains varying amounts of water. The 375 g. required in these directions are equivalent to 319 g. of anhydrous material.

The total time required for the oxidation is twenty-four hours. It is convenient to start the reaction in the morning. In this way the last part of the reaction, which requires no attention, will be accomplished during the night. The regulation of the temperature is necessary, as the reaction proceeds very slowly below 20°; on the other hand, the dichloroacetone itself is oxidized at a somewhat higher temperature than 25°.

3. Other Methods of Preparation

The preparation of dichloroacetone by the following methods is described in the literature: the direct chlorination of acetone;¹ the oxidation of dichlorohydrin;² the action of silver chloride on diiodoacetone;³ the action of dichloropropene ($\text{CH}_2\text{Cl}-\text{CCl}=\text{CH}_2$) and hypochlorous acid;⁴ the action of hydrochloric acid on ethoxymonochloroacetoacetic ester;⁵ and the hydrolytic cleavage of dichloroacetoacetic ester.⁶

¹ Jahresb. **1859**, 345; **1871**, 531; J. prakt. Chem. (2) **4**, 52 (1871); Ber. **7**, 467 (1874); **8**, 1330, 1438 (1875); **26**, 598 (1893); **42**, 3233 (1909); Ann. **279**, 315 (1894).

² Ber. **6**, 1210 (1873); **13**, 1706 (1880); **42**, 3233 (1909); Ann. **208**, 355 (1881); **269**, 46 (1892); Ann. chim. phys. (6) **9**, 145 (1886); Bull. soc. chim. (2) **36**, 19 (1881).

³ Ann. **192**, 93 (1878).

⁴ Compt. rend. **94**, 1428 (1882).

⁵ Ann. **269**, 18 (1892).

⁶ Ber. **43**, 3533 (1910).

V

p-DIMETHYLAMINO BENZALDEHYDE

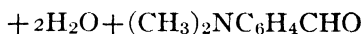
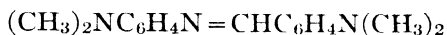
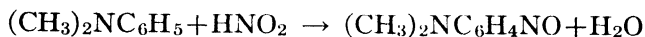

Prepared by ROGER ADAMS and G. H. COLEMAN.

Checked by H. T. CLARKE and W. W. HARTMAN.

1. Procedure

IN a 3-l. round-bottom flask fitted with a mechanical stirrer 150 g. of technical dimethylaniline are dissolved in 750 cc. of diluted hydrochloric acid (1 part concentrated acid to 1 part water). This solution is now cooled to 0° and a solution (previously cooled to 0°) of 90 g. of technical sodium nitrite in 150 cc. of water is added through a separatory funnel. During the addition of the nitrite solution, mechanical stirring should be employed and the flask cooled well with ice and salt. The addition is made at such a rate (thirty to forty minutes for the entire addition) that the temperature does not rise above 5°. The precipitate of nitroso dimethylaniline hydrochloride is filtered off with suction, then washed with about 300 cc. of diluted hydrochloric acid (1 : 1).

In a 2-l. beaker, 180 g. of technical dimethylaniline, 125 cc. of formaldehyde (technical 40 per cent), and 300 cc. of concentrated hydrochloric acid are mixed and heated for ten

minutes on a steam bath. The mixture is now placed in a hood and the nitroso dimethylaniline added all at once, or as rapidly as possible. The beaker is then covered with a watch glass. A vigorous reaction soon occurs and is complete in about five minutes. The resulting solution is transferred to a 5-l. flask and diluted to 4 l.; stirring is started, and a 25 per cent solution of sodium hydroxide is added until the red color disappears (about 650 cc. are required). The yellow benzylidene compound separates, is filtered with suction and washed with water. The moist precipitate is transferred to a 4-l. glass jar, covered with 1000 cc. of 50 per cent acetic acid and 250 cc. of formaldehyde, and stirred until twenty minutes after the benzylidene compound has gone into solution. While the mixture is being stirred vigorously to prevent lumping of the precipitate, 400 cc. of water and 200 g. of cracked ice are added during the course of five minutes. The dimethylaminobenzaldehyde generally separates gradually in fifteen to twenty minutes, but in some cases does not. If the precipitate does not form, the solution is placed in a refrigerator for a few hours or overnight. The mixture is filtered with suction and washed at least ten times with 300 cc. of water. The precipitate is sucked as dry as possible for fifteen to thirty minutes.

The slightly moist aldehyde is distilled under diminished pressure from an oil bath, by means of a 1-l. Claisen flask. A small amount of water comes over first, then the thermometer rises rapidly to the boiling point of the aldehyde ($180^{\circ}/22$ mm.). In changing receivers between the water fraction and the aldehyde, care should be taken to keep the side-arm of the distilling flask warm; otherwise, on starting the distillation again, the aldehyde will solidify in the side-arm and cause trouble. It is advisable not to collect the very last portion of the distillate with the main portion, as the former is frequently quite red. This is best added to crude material from another run. The main distillate is dissolved in 100 cc. of alcohol in a 2-l. beaker, then 1000 cc. of water are gradually added with vigorous mechanical stirring to prevent lumping. The aldehyde separates, and is filtered with suction. The product, when dry, weighs 125-

130 g. (56-59 per cent of the theoretical amount), and melts at 73°.

The aldehyde prepared in this way is in the form of small granular crystals, which vary in different runs from a flesh color to a lemon yellow. For practically all purposes, this slightly colored product is entirely satisfactory and is essentially pure, as can be judged by the melting point. For reagent purposes it is desirable to remove the color completely, particularly since the product obtained as just described has a tendency to take on a reddish tinge on exposure to light. Further purification can be accomplished by dissolving the aldehyde (it dissolves slowly) in dilute hydrochloric acid (1 part of concentrated acid, sp. gr. 1.19, to 6 parts of water), 125 g. of aldehyde requiring 700 cc. of the acid. The solution is placed in a jar and diluted with half its volume of water, and dilute sodium hydroxide solution (15-20 per cent) is added slowly with mechanical stirring. At the beginning, the aldehyde comes down slightly colored. After about 10 to 30 g. are precipitated, however, the product appears white; this point can be readily seen. The first precipitate is filtered off and added to the next run of crude material, or fractionally precipitated again from hydrochloric acid. The rest of the aldehyde is now precipitated by means of more sodium hydroxide solution, and comes down almost white. At the very end of the neutralization, particularly if the original product was quite yellow, the last 4 to 5 g. of aldehyde should be precipitated separately, as they are inclined to be slightly colored. If too much alkali is added towards the end of the neutralization, a brown color appears, but the addition of a little hydrochloric acid will destroy this color. The main portion of the precipitate is filtered and dried; it weighs 95-100 g., m. p. 73°. The succeeding runs yield 115-128 g. of finished product, on account of the extra crude material obtained from the distillation and reprecipitation of the previous run.

2. Notes

The aldehyde that is obtained without reprecipitation gradually takes on a pinkish tinge on exposure to light. After the reprecipitation, however, this characteristic disappears.

Thorough washing of the crude aldehyde is particularly desirable, as it removes a reddish impurity which tends to distil over and color the product lemon yellow or sometimes even brownish yellow. When such a brownish product is obtained, it is quite necessary to make a second precipitation, as well as to observe the directions mentioned in the purification of the crude aldehyde, namely, to precipitate the first few grams and the last few grams of the aldehyde separately. The precaution of rejecting the first and last portions of the precipitate is unnecessary in the reprecipitation. In the reprecipitation of a deeply colored product, the portion of aldehyde at the end may be even purplish in color and particular care must be taken to keep this separate.

Vigorous mechanical stirring must be employed during the precipitation of the crude aldehyde, as otherwise large lumps are formed which make washing difficult.

A previous investigator has mentioned that the crude product must be dried before distilling. This, however, is unnecessary. If the aldehyde is dried before distilling, it is possible to use a 500-cc. distilling flask instead of a 1-l. one.

In purifying the aldehyde by dissolving in acid and reprecipitating, it is essential not to use stronger acid than that specified (1 : 6), as stronger acid causes a deepening of the color of the solution. If the concentrated acid, which is to be diluted and used in this procedure, does not have a sp. gr. of 1.19, it will be necessary to add the equivalent amount of weaker acid in order to dissolve the *p*-dimethylaminobenzaldehyde. In purifying the aldehyde, sodium carbonate may be used in place of sodium hydroxide for precipitation, but it causes much foaming.

When the apparatus for distilling, etc., is all set up, a run such as described above requires about five to six hours for completion.

3. Other Methods of Preparation

p-Dimethylaminobenzaldehyde has been made by the condensation of chloral with dimethylaniline, and subsequent hydrolysis;¹ by the hydrolysis of tetramethyldiaminobenzhydrol with acetic acid;² by the condensation of dimethylaniline, formaldehyde and *m*-sulfo-*p*-tolyl hydroxylamine followed by hydrolysis;³ by the electrolytic reduction of a mixture of sodium nitrobenzene sulfonate, dimethylaniline and formaldehyde, and subsequent hydrolysis;⁴ by the reduction of a mixture of dimethylaniline, formaldehyde and sodium nitrobenzene sulfonate with iron and hydrochloric acid, followed by hydrolysis;⁵ by the condensation of alloxan with dimethylaniline followed by hydrolysis;⁶ by the condensation of dimethylaniline, formaldehyde and sodium *p*-toluidine sulfonate in the presence of hydrochloric acid and potassium dichromate followed by hydrolysis.⁷ The most satisfactory method, however, is the condensation of dimethylaniline, formaldehyde and nitroso dimethylaniline, followed by hydrolysis,⁸ a method which was first described by E. Noeltig and later perfected in detail by L. Baumann.

¹ Ber. **18**, 1519 (1885); **19**, 366 (1886); D. R. P. 61, 551; Frdl. **3**, 109 (1892).

² Ber. **27**, 3317 (1894).

³ D. R. P. 103,578; Frdl. **5**, 101 (1899).

⁴ D. R. P. 105,103; Frdl. **5**, 107 (1899).

⁵ D. R. P. 105,105; Frdl. **5**, 109 (1899).

⁶ D. R. P. 108,026; Frdl. **5**, 117 (1899).

⁷ D. R. P. 118,567; Frdl. **6**, 133 (1901).

⁸ Ber. **37**, 858 (1904); J. Biol. Chem. **41**, 146 (1920).

VI

ETHYL OXALATE

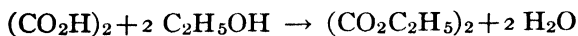

Prepared by H. T. CLARKE and ANNE W. DAVIS.

Checked by ROGER ADAMS and W. B. BURNETT.

1. Procedure

IN a 5-l. flask are placed 1 kg. of crystallized (hydrated) oxalic acid, 1.66 kg. of 95 per cent ethyl alcohol, and 1.33 kg. of

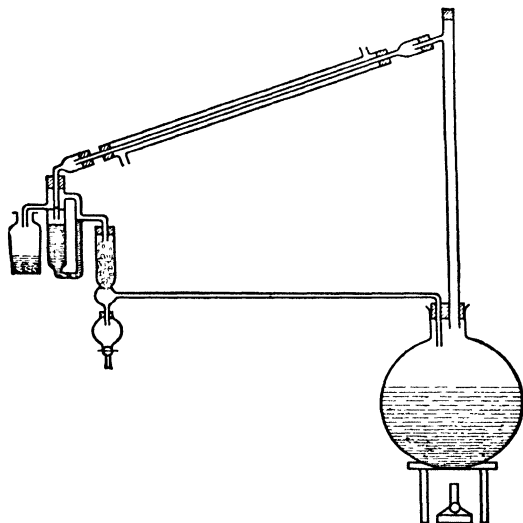

FIG. 1.

carbon tetrachloride. The flask is then fitted with a fractionating column, 1 meter long, to which is attached a condenser and an automatic separator so arranged that the lighter liquid flows

off to a receiver (Fig. 1). The heavier liquid flows through a tower of anhydrous potassium carbonate, and then returns to the reaction flask. The bottom of the tower is connected with a small separatory funnel through which any potassium carbonate solution, which flows from the solid in the tower, may be withdrawn from time to time.

The mixture in the flask is slowly distilled. As soon as about 500 cc. of the lighter liquid has collected, it is placed in a fractionating apparatus and distilled, the material which boils up to 79° being collected separately. This fraction, which consists principally of alcohol, with a little carbon tetrachloride and moisture, is dried with potassium carbonate and returned to the reaction mixture. The higher fractions are redistilled.

The above process is continued until the distillate no longer separates into two phases (about twenty-seven hours). The liquid in the flask is then distilled with the use of a column until the temperature of the vapor reaches 85° ; the residue is then distilled under reduced pressure, and the fraction which boils at $106-107^{\circ}/25$ mm. is collected. The yield is 920-960 g. of a colorless liquid (80-84 per cent of the theoretical amount).

2. Notes

Water, ethyl alcohol and carbon tetrachloride form a ternary mixture boiling at about 61° . This vapor mixture, on condensation, separates into two phases; the heavier liquid consists of carbon tetrachloride and alcohol with only small amounts of water; the lighter liquid consists of approximately 65 per cent alcohol, 25 per cent water and 10 per cent carbon tetrachloride. By taking advantage of this fact, it is possible to conduct the esterification at a temperature so low that the ethyl hydrogen oxalate first formed does not decompose into ethyl formate and other products, as is the case when the customary methods of esterification are employed.

The reaction may be carried out somewhat more expeditiously if the oxalic acid be dehydrated independently before it is mixed with the alcohol; indeed, it is also possible to remove the bulk

of the water from the alcohol itself by a similar method, before mixing it with the oxalic acid. However, since water is formed during the esterification, little is gained by this procedure.

It is not absolutely necessary to remove the last traces of water from the alcohol-carbon tetrachloride layer by means of potassium carbonate before returning it to the reaction mixture; this process is, however, so simple and requires so little attention that there is no doubt that it is of material aid in cutting down the time of operation. The advantages of using crystallized oxalic acid and commercial 95 per cent alcohol, instead of the anhydrous reagents, are obvious. When technical oxalic acid is used, the yields are usually smaller by 5 to 10 per cent.

The apparatus shown in Fig. 1 may be somewhat more simply constructed by using rubber connections in several places, thus eliminating a certain amount of glass blowing, and making a more flexible piece of apparatus. The side-arm of the separator may be made with two rubber connections,—one above and one below the tube leading to the potassium carbonate tube. The long return tube to the flask may be constructed with a rubber joint very near the carbonate tube and one near the flask.

3. Other Methods of Preparation

Ethyl oxalate has been prepared in poor yields by the following methods: by distilling a mixture of anhydrous oxalic acid and absolute alcohol;¹ by heating a mixture of anhydrous oxalic acid and 97 per cent alcohol under a reflux condenser and fractionating the resulting mixture;² by distilling a mixture of anhydrous oxalic acid and absolute alcohol, the vapor of absolute alcohol being passed simultaneously into the mixture;³ by allowing a saturated solution of oxalic acid in alcohol to stand for a long time at 40–50°.⁴

A good yield has been obtained by Anschütz⁵ by a method

¹ Jahresb. 1861, 598.

² J. prakt. Chem. (2), 34, 500 (1886).

³ Monatsh. 17, 614 (1896).

⁴ Ann. 65, 350 (1848).

⁵ Ber 16, 2414 (1883).

involving saturation of a mixture of crystallized oxalic acid and alcohol with hydrogen chloride, removal of the alcohol and water by distillation under reduced pressure, and repetition of the treatment with the alcohol and hydrogen chloride, the process being carried out several times.

VII

ETHYL PHENYLACETATE

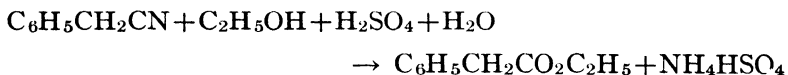

Prepared by ROGER ADAMS and A. F. THAL.

Checked by OLIVER KAMM.

1. Procedure

IN a 3-l. round-bottom flask, fitted with an efficient reflux condenser, are mixed 750 g. of 95 per cent alcohol, 750 g. of concentrated sulfuric acid and 450 g. of benzyl cyanide. The mixture, which soon separates into two layers, is heated to boiling over a low flame, for six to seven hours, cooled and poured into 2 l. of water, and the upper layer is separated. This is washed with a little 10 per cent sodium carbonate solution to remove small amounts of phenylacetic acid which may have been formed, and then distilled *in vacuo*. A small amount of water goes over first and then a pure product boiling $132-138^\circ/32$ mm. ($120-125^\circ/17-18$ mm.). The yield varies in general between 525 and 550 g. (83-87 per cent of the theoretical amount).

2. Notes

The benzyl cyanide can be most conveniently prepared according to the directions in preparation III (p. 9); the product which boils over a 5° range should be used.

In washing the layer of ethyl phenylacetate with sodium carbonate it is sometimes advisable to add a certain amount of sodium chloride so that the ester will separate more readily.

The product obtained is water-clear and practically colorless. Although the product is collected over a 5° range, most of the

liquid is found to boil over a 1° range, if distilled slowly without superheating.

The boiling point of ethyl phenylacetate is near that of benzyl cyanide. However, a Kjeldahl analysis of the product shows that only a trace of nitrogen compounds is present.

3. Other Methods of Preparation

Ethyl phenylacetate may be prepared by the treatment of benzyl cyanide with alcohol and hydrochloric acid gas.¹ It is much more convenient in the laboratory, however, to use sulfuric acid in place of hydrochloric acid; in fact, the yields obtained are better than those recorded in the literature. This ester may also be made by the esterification of phenylacetic acid with hydrochloric acid and alcohol;² or with alcohol and sulfuric acid;³ the following less important methods of preparation may be mentioned; the action of benzyl magnesium chloride upon ethyl chlorocarbonate,⁴ and the action of copper on a mixture of bromobenzene and ethyl chloroacetate at 180° .⁵

¹ Ber. **20**, 592 (1887); Ann. **296**, 361 (1897).

² Ber. **2**, 208 (1869).

³ Ann. **296**, 2, footnote (1897); Compt. rend. **152**, 1855 (1911).

⁴ Ber. **36**, 3088 (1903).

⁵ Ber. **2**, 738 (1869).

VIII

GLYCEROL α , γ -DICHLOROHYDRIN



Prepared by J. B. CONANT and O. R. QUAYLE.
Checked by O. KAMM and A. O. MATTHEWS.

1. Procedure

ONE kilo of 90 per cent glycerol (sp. gr. 1.243) and 20 g. of acetic acid are placed in a weighed 2-l. flask which is immersed in an oil bath heated to 100–110°. The flask is fitted with a two-hole stopper, which carries a long tube reaching to the bottom of the flask and a short exit tube. The former is connected to a hydrogen chloride generator, the latter to a catch-bottle and some system for absorbing any excess of hydrogen chloride. A stream of dry hydrogen chloride is passed into the mixture. The absorption of gas is very rapid at the start, but gradually falls off towards the end of the reaction; the stream of hydrogen chloride should be regulated accordingly. The flask is removed from time to time and weighed; when the absorption of gas practically ceases, the increase in weight will be about 875 g. (25 per cent more than the theoretical amount).

The product is now cooled, placed in a 4-l. beaker, and treated with solid sodium carbonate until just alkaline to litmus. Water is added from time to time, to facilitate the reaction with the sodium carbonate and to prevent the separation of salt; about 500 cc. are required. The mixture is transferred to a separatory funnel and the aqueous layer separated. The crude dichlorohydrin, which weighs 1250 g., is distilled *in vacuo*. The first fraction boiling below 68°/14 mm. weighs 225 g., and consists of water and some dichlorohydrin; the dichlorohydrin is collected between 68–75°/14 mm., and weighs about 775 g. The water

is separated from the first fraction, which is then redistilled and yields 100 g. of dichlorohydrin. A still further amount of material (40-45 g.) may be obtained by extracting with benzene, the aqueous layer obtained in the neutralization process. This is, however, hardly profitable. The neutralization and distillation will require about four hours.

The 875 g. of dichlorohydrin thus obtained boils over a 7° range; this is 70 per cent of the theoretical amount. Redistillation yields 700-720 g. boiling 70-73°/14 mm. (57 per cent of the theoretical amount).

2. Notes

The most convenient hydrogen chloride generator is that described by Sweeney.¹ Concentrated hydrochloric acid is introduced into concentrated sulfuric acid, by means of a dropping funnel and a *capillary tube leading to the bottom of the sulfuric acid container*. It is convenient to use a 3-l. bottle for this container and a 1-l. funnel to contain the hydrochloric acid. The gas is dried by passing through a wash-bottle containing concentrated sulfuric acid. An empty catch-flask should be connected between the generator and the absorption flask in case any glycerol tends to suck back at the start of the reaction. About 6 kg. of concentrated hydrochloric acid and 10 kg. of concentrated sulfuric acid are required in one run. The generating flask will have to be recharged every six hours; it should be half filled with sulfuric acid. Aside from this, the apparatus needs no attention. The oil bath can be conveniently heated on an electric hot plate.

The dichlorohydrin boiling over a 7° range is sufficiently pure for most purposes. It contains very little, if any, isomeric dichlorohydrin, since on oxidation it gives dichloroacetone in good yields.

3. Other Methods of Preparation

The following methods of preparing dichlorohydrin are described in the literature: the action of gaseous hydrogen

¹ J. Am. Chem. Soc. **39**, 2187 (1917).

chloride on glycerol;¹ the action of gaseous hydrogen chloride on glycerol mixed with an equal volume of acetic acid;² the action of hydrogen chloride gas on glycerol containing 1-2 per cent of some organic acid, as acetic, as a catalyst;³ the action of aqueous solution of hydrochloric acid on glycerol containing acetic acid as a catalyst;⁴ the action of sulfur monochloride on glycerol.⁵

The previous work, described in the literature, indicated that the best yields were obtained by the treatment of glycerol containing 1-2 per cent of acetic acid as a catalyst by gaseous hydrogen chloride. Therefore this method was employed.

¹ Ann. **88**, 311 (1853); Ann. chim. phys. (3) **41**, 297 (1854); (6), **22**, 437 (1891); Bull. soc. chim. (2), **48**, 237 (1887); Z. physik. Chem. **92**, 717 (1918); **93**, 59 (1919); **94**, 691 (1920); D. R. P. 263,106; 272,337; Frdl. **11**, 33 (1912).

² Ann. Spl. **1**, 218 (1861); Ann. chim. phys. (3) **60**, 18 (1860).

³ D. R. P. 197,308; Frdl. **9**, 33 (1908).

⁴ D. R. P. 197,309; Frdl. **9**, 33 (1908).

⁵ Ann. **122**, 73 (1862); **168**, 43 (1873); Ber. **5**, 354 (1872); Ann. chim. phys. (6) **22**, 437 (1891).

IX

GLYCEROL α -MONOCHLOROHYDRIN



Prepared by J. B. CONANT and O. R. QUAYLE.
Checked by O. KAMM and A. O. MATTHEWS.

1. Procedure

FIVE HUNDRED grams of glycerol (90 per cent) and 10 g. of glacial acetic acid are mixed in a weighed 1-l. flask, which is placed in an oil bath heated to 105–110°. A rapid stream of dry hydrogen chloride is introduced into the mixture. The flask is removed from the bath from time to time and reweighed. At the end of about four hours the flask will have gained 190 g. in weight. The reaction is then complete.

The product is distilled under diminished pressure. Below 114°/14 mm., 220–250 g. distil; this portion is mostly water. The monochlorohydrin is collected between 114–120°/14 mm.; it weighs 360 g., which is 66 per cent of the theoretical amount. About 20 g. more may be obtained by neutralizing the first fraction and separating the aqueous layer.

2. Notes

The same apparatus is employed as in the preparation of dichlorohydrin (preparation VIII, p. 29).

The portion boiling 120–130°/14 mm. only amounts to 15–30 g., showing that very little of the β -compound is formed. This is further shown by the fact that the dichlorohydrin formed by continued action of hydrogen chloride under the same conditions contains very little, if any, α , β dichloride.

Two kilograms of concentrated sulfuric acid and 750 g. of concentrated hydrochloric acid are sufficient to produce the necessary amount of hydrogen chloride.

A light straw-colored final product is obtained in some cases.

An alternative procedure which is slower and gives slightly lower yields, but does not require a hydrogen chloride generator, is as follows:

Three hundred grams of glycerol, 600 cc. of hydrochloric acid (sp. gr. 1.19) and 15 g. of glacial acetic acid are heated under a reflux condenser for ten hours, in a 2-l. flask. The boiling should be very gentle in the early stage of the reaction, as considerable hydrochloric acid vapor is evolved. As the reaction progresses, and the evolution of acid vapors diminishes, the mixture is more strongly heated.

The reaction products are distilled under ordinary pressure until the temperature of the liquid has reached 140° (thermometer bulb immersed in the liquid). The residual products are distilled under diminished pressure, and the following fractions obtained. (1) Up to $115^{\circ}/11$ mm.; (2) $115-117^{\circ}/11$ mm.; (3) $117-170^{\circ}/11$ mm. (1) is mostly aqueous hydrochloric acid; (2) is the monochlorohydrin; and (3) is glycerol. The second portion is redistilled and the portion boiling at $115-118^{\circ}/11$ mm. or $133-136^{\circ}/20$ mm. is collected. The yield is 190-205 g., 53-57 per cent of the theoretical amount.

3. Other Methods of Preparation

The following methods of preparing monochlorohydrin are described in the literature: action on glycerol of gaseous hydrogen chloride;¹ action of gaseous hydrogen chloride on glycerol mixed with an equal volume of acetic acid;² action of aqueous hydrochloric acid on glycerol³ alone or with an organic acid (1-2 per cent), such as acetic, as a catalyst;⁴ gaseous hydrogen

¹ Ann. 88, 311 (1853); Ann. chim. phys. (3) 41, 207 (1854); D. R. P. 254,709; 269,657; Frdl. 11, 31 (1912).

² Ann. chim. phys. (3) 60, 18 (1860).

³ D. R. P. 180,668; Frdl. 8, 27 (1907); J. Am. Chem. Soc. 42, 2096 (1920).

⁴ D. R. P. 197,309; Frdl. 9, 34 (1908).

chloride with an organic acid, as acetic, as a catalyst;¹ gaseous hydrogen chloride with the ester of an organic or inorganic acid as a catalyst;² the action of sulfur monochloride on glycerol.³

¹ D. R. P. 197,308; Frdl. **9**, 33 (1908).

² D. R. P. Anm. 23,510; 16,579; Frdl. **9**, 36 (1908).

³ D. R. P. 201,230; Frdl. **9**, 35 (1908).

X

HYDRAZINE SULFATE

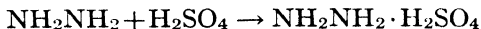

Prepared by ROGER ADAMS and B. K. BROWN.

Checked by J. B. CONANT and W. L. HANAWAY.

1. Procedure

A NORMAL solution of sodium hypochlorite is prepared as follows: in a 5-l. round-bottom flask are placed 1800 g. of sodium hydroxide solution (300 g. of sodium hydroxide to 1500 g. of water) and 1500 g. of ice. Chlorine gas is then passed into the solution until it has gained in weight approximately 213 g. During this addition, the solution must be kept thoroughly cooled with ice, in order that chlorates will not be formed. After all the chlorine has been passed in, it is necessary to be certain that the mixture is slightly alkaline, since any excess of free chlorine in the solution prevents the formation of hydrazine.

In a 14-inch evaporating dish are placed 1500 cc. of C. P. ammonia water (sp. gr. 0.90), 900 cc. of distilled water, 375 cc. of 10 per cent gelatine solution, and 1200 cc. of the normal sodium hypochlorite solution prepared as above. This mixture is heated as rapidly as possible and boiled down until one-third of the original volume is left. This solution is then cooled thoroughly with ice and filtered with suction, first through two layers of toweling and then through one thickness of ordinary filter paper over cloth, in order to remove finely divided solid impurities. The solution is then placed in a precipitating jar, and cooled down thoroughly (0°) with ice and salt; 10 cc. of concentrated sulfuric acid for each 100 cc. of solution are gradually added with constant stirring. A precipitate of

hydrazine sulfate ($\text{NH}_2\text{NH}_2 \cdot \text{H}_2\text{SO}_4$) forms. The mixture is allowed to stand in the cold for a few hours in order to complete the precipitation, and is then filtered by suction in the usual way and washed with cold alcohol. The yield varies from 53 g. to 58 g. per 1500 cc. of ammonia water (34-37 per cent of the theoretical amount). The product is perfectly white and crystalline, and satisfactory for almost any purpose. If an absolutely pure product is desired, it must be recrystallized from water. For every 21 g. of crude product, 100 g. of boiling water are used. If the crude hydrazine is brown, it is advisable to use a little bone-black. After the mixture has been filtered and cooled to 0° , 19 g. of pure white crystals are obtained.

2. Notes

In the preparation of the sodium hypochlorite solution it is quite necessary that the mixture be kept cold and be alkaline to red litmus paper at the end of the reaction, if good yields of hydrazine are to be obtained.

Since iron is an anti-catalyzer, it is necessary to use distilled water throughout the process.

As a viscolizer, a substance such as starch, glycerol, glue or gelatine may be used; the last, however, gives by far the most satisfactory results.

In order to obtain a pure white hydrazine sulfate as the first precipitate, it is necessary to cool the hydrazine solution thoroughly and filter it twice before the sulfuric acid is added. Moreover, the sulfuric acid must be added slowly and with stirring. If these conditions are not followed, material containing brown particles results.

The mother liquor obtained from the crystallized hydrazine sulfate contains a small amount of hydrazine. If 200 g. of copper sulfate are dissolved in water and added to 10 l. of the filtrates from the above processes, a light-blue crystalline precipitate of the double salt of copper sulfate and hydrazine sulfate will be formed after ten hours. This salt, when suspended in ten times its weight of distilled water and treated with hydrogen sulfide,

decomposes into copper sulfide and hydrazine sulfate. After the copper salt has been filtered off, the solution is concentrated until the hydrazine sulfate crystallizes. The yield of product is small, so that it is hardly advisable to undertake this recovery in the laboratory.

It is possible for one man, simultaneously evaporating six dishes of the hydrazine mixture, to turn out from 20 to 25 runs in nine hours. The time for the evaporation of a solution, such as is mentioned in the experimental part, with a four-flame Bunsen burner, is two to three hours; if the evaporation is carried out more slowly than this, the yield of product is distinctly diminished.

3. Other Methods of Preparation

Hydrazine salts have been prepared by the action of hypochlorites on ammonia¹ or urea;² by the hydrolysis of salts of sulfohydrazimethylene disulfonic acid;³ by the hydrolysis of triazoacetic acid;⁴ by the reduction of diazoacetic ester;⁵ by the reduction of nitroguanidine followed by hydrolysis;⁶ by the reduction of the nitroso derivatives of hexamethylene tetramine;⁷ by the reduction of nitrates or nitrites with zinc in neutral solution;⁸ by the action of sodium bisulfite on hyponitrous acid

¹ D. R. P. 192,783; Chem. Zentr. **1908** (I), 427; Chem. Ztg. **31**, 926 (1907); D. R. P. 198,307; Chem. Zentr. **1908** (I), 1957; Eng. Pat. 22,957; C. A. **2**, 1999 (1908); U. S. Pat. 910,858; C. A. **3**, 1065 (1909); French Pat. 382,357; C. A. **3**, 2358 (1909); Ber. **40**, 4588 (1907); Laboratory Manual of Inorganic Preparations, by A. B. Lamb, Harvard University, Cambridge, Mass.

² J. Russ. Phys. Chem. Soc. **37**, 1 (1905); Chem. Zentr. **1905** (I) 1227; D. R. P. 164,755; Frdl. **8**, 53 (1905); French Pat. 320,430; J. Soc. Chem. Ind. **22**, 1063 (1903); Chem. Zentr. **1905** (I) 1227.

³ D. R. P. 79,885; Frdl. **4**, 26 (1895); Ber. **28**, 2381 (1895).

⁴ Ber. **20**, 1632 (1887); Chem. News **55**, 288 (1887); D. R. P. 47,600; Frdl. **2**, 554 (1889); J. prakt. Chem. (2) **39**, 27 (1889).

⁵ Ber. **27**, 775 (1894); **28**, 1848 (1895); D. R. P. 58,751; Frdl. **3**, 15 (1891); D. R. P. 87,131; Frdl. **4**, 28 (1896).

⁶ Ann. **270**, 31 (1892); D. R. P. 59,241; Frdl. **3**, 16 (1891); Eng. Pat. 6,786; J. Soc. Chem. Ind. **11**, 370 (1892).

⁷ D. R. P. 80,466; Frdl. **4**, 27 (1895); Ann. **288**, 232 (1895).

⁸ Eng. Pat. 11,216; J. Soc. Chem. Ind. **14**, 595 (1895).

followed by reduction;¹ by the reduction of $K_2SO_3N_2O_2$;² by the action of ammonia on dichlorourea;³ by the reduction of nitrosoparaldimin;⁴ by the action of copper sulfate on ammonia at high temperatures;⁵ by the reduction of methylene diisonitrosoamine;⁶ by the hydrolysis of the addition product of diazoacetic ester and fumaric or cinnamic esters.⁷

¹ Ber. **33**, 2115 (1900); Ann. **288**, 301 (1895).

² Ber. **27**, 3498 (1894).

³ J. Chem. Soc. **95**, 235 (1909); Chem. News **98**, 166 (1908).

⁴ Ber. **23**, 752 (1890).

⁵ Chem. News **66**, 223 (1892).

⁶ Ber. **27**, 3292 (1894);

⁷ Ber. **21**, 2637 (1888).

XI

MESITYLENE

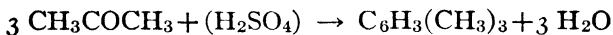

Prepared by ROGER ADAMS and R. W. HUFFERD.
Checked by H. T. CLARKE and W. W. HARTMAN.

1. Procedure

IN a 12-l. round-bottom flask, arranged so that the contents can be mechanically stirred, are placed 4600 g. (5750 cc.) of technical acetone. The flask is then well cooled with an ice-and-salt mixture, until the temperature of the acetone is between 0° and 5°. Stirring is started, and 4160 cc. of commercial concentrated sulfuric acid is run in at such a rate that the temperature of the mixture never rises above about 10°. This addition is accomplished in about five to ten hours. The stirring is continued for three to four hours longer, while the flask still remains immersed in the original freezing mixture to which no further amount of ice is added. The mixture is then allowed to stand at room temperature for eighteen to twenty-four hours.

A 5-l. round-bottom flask is fitted with a rubber stopper or a cork stopper coated with pitch, carrying two glass tubes, one of which (for the entrance of steam) reaches to the bottom of the flask, while the other extends into the open end of a condenser set for downward distillation. The stopper should be wired into the flask. The glass delivery tube into the condenser should not be less than a 12-mm. bore, and the condenser should consist of two 120-cm. water-cooled condensers attached end to end. To the end of the condensing system, an adapter is attached, the small end of which is at least 8 mm. in bore and is fitted tightly into a stopper in a 2-l. suction flask. To the side-

arm of the suction flask is attached a tube leading to an exhaust fan, in order to carry away the gases which are evolved during the subsequent distillation. In the 5-l. flask are placed about 2 l. of the sulfuric acid-acetone reaction mixture, and the flask is then heated with a free flame and shaken occasionally. A reaction starts at the end of about fifteen or twenty minutes, as shown by the evolution of gas (chiefly sulfur dioxide), and is allowed to run for about three minutes. At the end of this time, a current of steam is passed in and continued for about three minutes. During this period a large proportion of the mesitylene distils and should be kept separate from the subsequent distillate. The steam distillation is continued at such a rate that about 800 cc. distils in twenty-five to thirty minutes and is collected as a second distillate. At the end of this time, the distillation is stopped, the water poured off from the distilling flask and the tarry material emptied out while hot into waste jars. The total amount of original reaction mixture requires five distillations similar to the one just described. The first distillates from each of the five distillations are mixed, and the layer of mesitylene is separated from the water. This is shaken with sodium hydroxide solution until no more odor of sulfur dioxide is noticeable, then washed twice with water and distilled. The first portion of the distillate consists of a small amount of water and mesitylene and is added to the combined second distillates. The fraction which distils up to 210° is saved. The second distillates are combined, washed in the same way as the first and then distilled; the fraction which distils up to 210° is combined with the corresponding fraction from the first distillates.

These combined fractions (which boil up to 210°) and 15 g. of sodium are placed in a 2-l. distilling flask, the side-arm of which is closed with a rubber tube and pinchcock and which is fitted with a reflux condenser. The mixture is heated just below the boiling point for about three hours, during which time the impurities are attacked by the molten sodium, and a gelatinous, reddish mass forms. The reflux condenser is now removed and one set for downward distillation is attached to the side-arm. The mixture is distilled and about two-thirds of the liquid

removed in this way. The residue is cooled, the liquid poured off from solid material and distilled up to 210° .

The distillates from the sodium treatment are now fractionated with a good column (at least 30 cm. long), and the portion which boils at $163-167^{\circ}$ is collected. The yield of this fraction varies in different runs from 430 to 470 g. (13-15 per cent of the theoretical amount), but very often will be as high as 500 g., and has reached, in certain experiments, 600 g.

An alternative method for the purification of the crude material has been employed by Clarke and Hartman, and yields a slightly higher-grade product than the sodium method. It is as follows:

The combined distillates are treated with an equal volume of concentrated sulfuric acid and the solution warmed on a water bath for an hour, under a reflux condenser, with occasional shaking or, better, with mechanical stirring. Upon cooling, mesitylene sulfonic acid crystallizes and the unsulfonated material remains as an oil on the surface. The mixture is filtered through flannel or a "filtrose" plate, and the crystals are washed with 60-70 per cent sulfuric acid. The oily layer is again warmed with sulfuric acid, as before. The acid and oily filtrates from the two sulfuric acid treatments are steam distilled, and the distillate combined with the next batch of material. The crystals are mixed with 2 l. of 15 per cent hydrochloric acid and heated under a reflux condenser for two to three hours. The reaction mixture is now steam distilled, the mesitylene separated, dried over calcium chloride and fractionated; the portion which boils at $163-167^{\circ}$ is collected.

2. Notes

The cooling of the reaction flask must be very efficient, a 10-15 cm. blanket of a thorough mixture of ice and salt being used. If this precaution is not employed, the time for the addition of the sulfuric acid is greatly increased, provided the temperature of the reaction mixture is still kept within the limits mentioned.

If a cork is used for the steam distillation of the reaction

mixture of acetone and sulfuric acid, it should be coated well with pitch and wired into the flask. This is necessary because the vapors of the reaction mixture attack an ordinary cork very badly, and soften it so much that it is necessary to rewire it to prevent it from slipping out. A rubber stopper is satisfactory and may be used in several runs.

The evolution of gas is so vigorous that it is not possible to distil more than 2 l. of the original reaction mixture at one time in the apparatus described. The connections on the apparatus, in which the mesitylene is obtained from the crude reaction mixture, should be tight, since the fumes evolved during the heating are very irritating.

The product which distils during the initial heating and the three minutes of steam distillation is mainly satisfactory material; the rest of the steam distillation yields only a small amount of pure product. The two portions of the distillate are, therefore, kept separate, since the second distillate always contains a considerable amount of high-boiling product which tends to cause emulsification of the alkali in the purification. No recovery of acetone is made.

The mechanism of the reaction is undoubtedly as follows: when the sulfuric acid and acetone are in contact for long periods of time, several molecules of the acetone condense to form aldol condensation products. These do not break down into mesitylene until the temperature is raised in the second part of the experiment.

While the original reaction mixture is standing, the temperature gradually rises to 40° or 50° in the course of six to ten hours, and then gradually cools off again. It is probable that at the end of this time (when the flask has cooled again) the reaction mixture could be distilled with nearly as good a yield as is obtained after standing eighteen to twenty-four hours.

The wide variation in yields which are mentioned in the experimental part is probably due to a slight change in the grade of the chemicals which are used in this preparation.

3. Other Methods of Preparation

The cheapest and most convenient method by which mesitylene may be prepared is by the action of a dehydrating agent upon acetone; the agent most commonly used is sulfuric acid.¹ It has been shown also that phosphoric acid will convert acetone to mesitylene.² A number of other methods have also been used for the preparation of mesitylene: the action of sulfuric acid on methyl acetylene;³ the action of sulfuric acid on mesityl oxide and phorone;⁴ the action of aluminium chloride on methyl chloride and benzene;⁵ the action of mineral acids upon mesityl or benzoyl mesitylene;⁶ the action of phosphoric acid upon diaceto-mesitylene;⁷ the treatment of methylene-3-dimethyl-, 5-cyclo-hexene-1 with bromine and then with alcoholic potash.⁸

¹ Ann. **141**, 131 (1867); **147**, 43 (1868); **278**, 210 (1893); Bull. soc. chim. (2) **40**, 267 (1883); J. prakt. Chem. (1) **15**, 129 (1838); Am. Chem. J. **15**, 256 (1893); **20**, 807 (1898).

² J. Chem. Soc. **99**, 1251 (1911).

³ Ber. **8**, 17 (1875).

⁴ Ber. **7**, 1169 (1874); **10**, 858 (1877).

⁵ Ber. **12**, 329 (1879); Ann. chim. phys. (6) **1**, 461 (1884).

⁶ Ber. **32**, 1910 (1899).

⁷ Ber. **32**, 1563 (1899).

⁸ Ber. **43**, 3093 (1910).

XII

METHYL RED



Prepared by H. T. CLARKE and W. R. KIRNER.

Checked by ROGER ADAMS and J. B. DAVIS.

1. Procedure

TECHNICAL anthranilic acid (generally about 95 per cent pure) (685 g.) is dissolved in 1.5 l. of water and 500 cc. of concentrated hydrochloric acid (sp. gr. 1.17), by heating. The insoluble dark impurity present in small amounts is filtered off, and the filtrate is transferred to a 16-l. crock and chilled with stirring. It is then mixed with a mush of 2.5 kg. of ice and 750 cc. of concentrated hydrochloric acid. The crock is cooled externally with ice, and the contents stirred continuously. When the temperature reaches about 3°, a filtered solution of 360 g. of sodium nitrite in 700 cc. of water is dropped in slowly, through a long capillary tube reaching below the surface of the liquid, until a faint but permanent reaction to starch potassium iodide paper is obtained; the temperature is kept between 3° and 5°. This operation requires all but about 30 cc. of the nitrite solution and occupies one and a half to two hours. To the solution of the diazonium salt are now added 848 g. of dimethylaniline; this may be done rapidly, as the temperature does not rise appreciably. Stirring is continued for one hour, the temperature being kept at 5°. Five hundred cc. of a filtered solution of

680 g. of crystallized sodium acetate diluted to 1200 cc. are then added, and the stirring continued for four hours. If a foamy solid rises to the surface during this time and refuses to become incorporated by the stirrer, a few drops of ethyl acetate may be added to reduce the foam. The mixture is allowed to stand overnight in an ice bath which is well insulated by several thicknesses of burlap; the temperature must be kept below 7° to get a good yield of product. The remainder of the sodium acetate solution is then added with stirring, and after the mixture has been stirred for an additional period of one to three hours, the temperature is allowed to rise slowly to $20-25^{\circ}$ in the course of twenty-four hours. Just enough sodium hydroxide solution is then added, with stirring, to cause the mixture to have a distinct odor of dimethylaniline (about 240 cc. of a 40 per cent solution are generally required), and the mixture is allowed to stand for forty-eight hours or longer at room temperature ($20-25^{\circ}$).

The solid is then filtered off, washed first with water, then with 400 cc. of 10 per cent acetic acid (to remove the dimethylaniline) and finally with distilled water. The last filtrate is generally pale pink. The solid is sucked as dry as possible, spread out on a tray in order to allow most of the water to evaporate (fifteen to twenty hours) and then suspended in 4 l. of methyl alcohol in a 12-l. flask. This mixture is stirred on the steam bath under a reflux condenser for one to two hours, allowed to cool slowly, and then chilled in an ice bath and filtered. The solid product is washed with a second 4 l. of cold methyl alcohol. After being dried in air, the product varies in weight from 820 to 870 g.

The product is extracted with boiling toluene in the following manner: 150 g. are placed in a fluted filter paper of 29 cm. diameter in a 25-cm. glass funnel which passes through the cork of a 2-l. flat-bottom conical flask containing 1250 cc. of toluene (Fig. 2). The flask is heated on an electric stove, and a 12-l. round-bottom flask is placed on the funnel to act as a condenser, cold water being run through the flask. The toluene is boiled until the condensed liquid runs through almost colorless (this requires from four to ten hours). The heating is then discontinued,

and, as soon as the liquid ceases to boil, the flask is removed to a bath containing water at $90-100^{\circ}$; the level of the water should be slightly above the level of the liquid in the flask. This arrangement permits the temperature to fall slowly so that large crystals are obtained. In the meantime a second conical flask containing 1250 cc. of toluene is attached to the funnel, and a new charge of 150 g. of crude methyl red is placed in the paper. When extraction is complete it is found that a certain amount of black

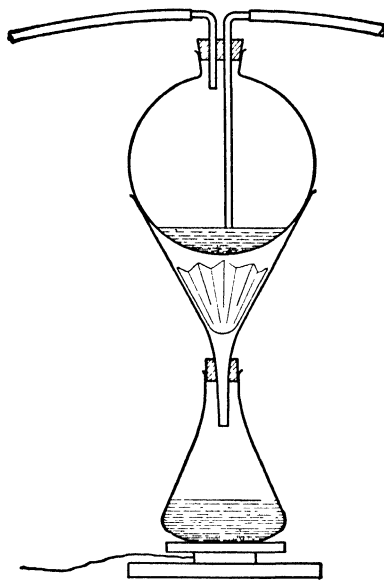

FIG. 2.

amorphous insoluble matter remains on the filter; this is discarded. The crystals of methyl red are filtered off and washed with a little toluene. The weight of pure material is 755-805 g. The mother liquors are concentrated to one-fourth of their volume, and the crystals which separate on cooling are recrystallized from fresh toluene. The recovered toluene can, of course, be employed again. The total yield of pure methyl red is 790-840 g. It melts at $181-182^{\circ}$.

The watery mother liquors from the crude methyl red are

rendered alkaline with sodium hydroxide and distilled until no more dimethylaniline passes over. In this way 250 to 400 g. of moist dimethylaniline are recovered.

2. Notes

The amount of hydrochloric acid indicated must not be reduced; otherwise, diazoamino compounds are formed.

It is essential to keep the temperature low while unreacted diazobenzoic acid remains in solution, in order to avoid decomposition. If this precaution is not taken, the yields are considerably diminished, through the formation of tarry by-products.

The use of a capillary tube for the addition of sodium nitrite prevents loss of nitrous acid by local reaction at the surface of the acid solution. The tube should not be tightly connected to the dropping funnel, but should be so arranged that air is sucked through with every drop. In this way, the entrance of the acid liquor into the capillary is prevented.

The formation of the azo compound takes place slowly on the addition of the dimethylaniline, but the speed of the reaction is greatly increased when the hydrogen ion concentration is lowered by the addition of the sodium acetate. It is nevertheless necessary to allow the reaction mixture to stand a long time; if the product be filtered off after only twenty-four hours, a further quantity of dye will separate from the filtrate on standing. The hydrochloride of methyl red is only sparingly soluble in cold water, and is apt to separate in blue needles if the acidity is not sufficiently reduced.

The alcoholic filtrate, obtained on digesting and washing the crude methyl red, contains a more soluble red by-product which gives a brownish-yellow solution in alkali. The methyl alcohol may be recovered with very little loss by distillation; it is, however, impracticable to attempt to recover any methyl red from the residue, owing to the tarry nature of the by-product. The proportion of this by-product is greatly increased if the temperature of the mixture is allowed to rise too soon after the addition of the sodium acetate.

Methyl red is described as crystallizing in needles from glacial acetic acid; on recrystallization from toluene it separates in plates.

When the methyl red is crystallized from toluene, it sometimes separates in the form of bright-red lumps, probably on account of too rapid crystallization. Under these conditions it is advisable to crystallize again, using a somewhat larger amount of toluene. The sodium salt may be prepared by dissolving the crude product in an equal weight of 35 per cent sodium hydroxide which has been diluted to 3 or 4 liters, filtering and evaporating under diminished pressure. The isolation of methyl red as the sodium salt avoids the toluene extraction.

It is advisable to titrate the crude anthranilic acid with standard alkali and phenolphthalein before starting the experiment. In checking these directions, an 80 per cent anthranilic acid was used; it gave a correspondingly lower yield of methyl red (650–700 g.). The yield of methyl red is about 65 to 70 per cent based on the dimethylaniline actually used up, but only 58–63 per cent based on the anthranilic acid actually present in the technical anthranilic acid employed.

3. Other Methods of Preparation

Methyl red was first prepared¹ by diazotization of anthranilic acid in alcoholic solution, the product being allowed to react with dimethylaniline in the same solvent. It has been stated² that this process does not work satisfactorily and yields a different product, of brownish-red color.

The preparation of methyl red in aqueous solution has been described by two workers, one of whom³ gives but few details and claims a nearly quantitative yield; the other⁴ gives fuller details and states the yield to be 43.1 per cent of the theory. The recrystallization of methyl red from toluene is stated⁵ to yield a product melting at 183°.

¹ Ber. **41**, 3905 (1908).

² Chem. Zentr. **1910**, (I), 960; **1910**, (II), 1561.

³ J. Chem. Soc. **97**, 2485 (1910).

⁴ C. A. **14**, 3406 (1920).

⁵ J. Chem. Soc. **99**, 1334 (1911).

XIII

p-NITROBENZOIC ACID

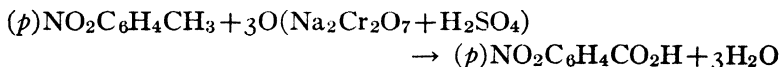

Prepared by O. KAMM and A. O. MATTHEWS.
Checked by H. T. CLARKE and W. W. HARTMAN.

1. Procedure

IN a 5-l. round-bottom flask, fitted with a mechanical stirrer, are placed 680 g. of sodium dichromate, 1500 cc. of water, and 230 g. of *p*-nitrotoluene. Stirring is started, and 1700 g. of concentrated sulfuric acid are allowed to flow in during about thirty minutes. The heat of dilution of the sulfuric acid will cause the nitrotoluene to melt, and rapid oxidation will soon take place. The last half of the sulfuric acid must be added gradually, in order to prevent too violent a reaction. Since a small amount of nitrotoluene is volatilized, it is advisable to carry on this work under a hood.

After the sulfuric acid has been added and the spontaneous heating of the reaction mixture has subsided, the mixture is heated to gentle boiling for about half an hour. After the reaction mixture has cooled, 2 l. of water are added, the cooled solution is filtered through a cloth filter, and the product washed with about 1 l. of water. In order to remove the chromium salts as completely as possible, the crude nitrobenzoic acid is warmed on the water bath and agitated with 1 l. of dilute (5 per cent) sulfuric acid solution. After cooling, the product is again filtered. It is then dissolved in 5 per cent sodium hydroxide solution, filtered from any chromium hydroxide remaining, and also from unchanged nitrotoluene. The filtrate, which should be light yellow or greenish in color, is acidified with dilute sulfuric acid, with stirring. It is usually preferable to run the

alkaline solution into the dilute sulfuric acid, rather than to use the reverse procedure, for the precipitation of the nitro acid. The precipitated product is filtered with suction, washed thoroughly, and dried. The product should possess only a light-lemon color. The yield should be 230-240 g. (80-85 per cent of the theoretical amount).

For a product of special purity, crystallization from benzene is advisable. For most purposes, however, the nitrobenzoic acid may be used without crystallization, since its melting point is found to be within 2° of the correct value of 238°.

2. Notes

The above procedure differs from that recorded in the literature, mainly in the use of a fairly large excess of sulfuric acid. This shortens the reaction time from forty hours to about one hour, which is especially convenient in the preparation of the acid on a laboratory scale. Because of the use of this large excess of sulfuric acid, the reaction is apt to be rather violent if the directions given are not carefully followed. The oxidation should be carried out under a hood. Small amounts of nitrotoluene are lost by volatilization, but this loss is not serious, as can be seen from the yield of product obtained.

Ten or 20 g. of unchanged nitrotoluene can be recovered from the reaction mixture by steam distillation, but the value of the by-product would not pay for the time spent in recovery.

The washing of the crude reaction product with dilute sulfuric acid is advisable, if good material is to be obtained. If an efficient centrifuge is available for use at this stage of the operation, this separate washing may prove to be less essential.

When a sparingly soluble organic acid is precipitated from fairly concentrated solution, the precipitate is liable to carry down with it some of the salt of the organic acid. Addition of the salt solution to the mineral acid, with stirring, avoids this difficulty.

3. Other Methods of Preparation

The nitration of benzoic acid produces only very small yields of the *p*-nitro product.¹ The only practical method for the preparation consists in the oxidation of *p*-nitrotoluene, although for this purpose various oxidizing agents are used. In addition to nitrotoluene, *p*-nitrobenzyl alcohol, *p*-nitrocinnamic acid and similar compounds may be oxidized, but their cost is prohibitive in comparison with that of the cheaper nitro hydrocarbon.

p-Nitrotoluene may be oxidized by means of strong nitric acid,² chromic acid mixture,³ or permanganates.⁴ Electrolytic oxidation⁵ has also been proposed. The procedure given above involves the use of chromic acid mixture, but, owing to a change in the concentration of sulfuric acid, the time of reaction is greatly shortened and the preparation is thus considerably improved.

¹ Ber. **8**, 528, 536 (1875).

² Ann. **127**, 137 (1863); **128**, 257 (1863).

³ Ann. **130**, 335 (1866).

⁴ J. Am. Chem. Soc. **41**, 1575 (1919).

⁵ D. R. P. 117,129; Frdl. **6**, 112.

XIV

p-NITROBENZYL CYANIDE

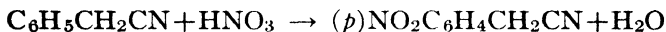

Prepared by G. R. ROBERTSON.

Checked by ROGER ADAMS and H. O. CALVERY.

1. Procedure

IN a 2-l. round-bottom flask, fitted with a stopper holding a dropping funnel and a mechanical stirrer, is placed a mixture of 275 cc. of concentrated nitric acid (sp. gr. 1.42) and 275 cc. of concentrated sulfuric acid (sp. gr. 1.84). This is cooled to 10° in a freezing mixture, and 100 g. of benzyl cyanide (free from alcohol and water) are run in slowly, at such a rate that the temperature remains at about 10° and does not exceed 20°. After all the benzyl cyanide has been added (about one hour), the ice bath is removed, the mixture is stirred for an hour and then poured on to 1200 g. of crushed ice. A pasty mass slowly separates; more than half of this mass is *p*-nitrobenzyl cyanide, the other constituents being *o*-nitrobenzyl cyanide, and a variable amount of an oil which resists hydrolysis; apparently no dinitro compounds are formed. The mass is filtered on a porcelain funnel with suction, pressed well to remove as much oil as possible, and dissolved in 500 cc. of boiling alcohol (95 per cent). On cooling, *p*-nitrobenzyl cyanide crystallizes; the mother liquor, on distillation, gives an impure alcohol which can be used for the next run. Recrystallization from 550 cc. of 80 per cent alcohol (sp. gr. 0.86 to 0.87) yields 70 to 75 g. (50-54 per cent) of a product which melts at 115-116°.

This product is satisfactory for most purposes, and incidentally for the preparation of *p*-nitrophenylacetic acid. Occa-

sionally it must be free even from traces of the ortho compound, and in this case should be crystallized again from 80 per cent alcohol; it then melts at 116–117°.

2. Notes

Fuming nitric acid may be used in nitrating benzyl cyanide, but the method here described is cheaper.

The yield of 70 g. is obtained from benzyl cyanide, which boils over a 5° range prepared as described in preparation III (p. 9). Very pure benzyl cyanide will give a slightly higher yield, while commercial grades may give only 50 g. of *p*-nitrobenzyl cyanide and much oil.

The reaction has been also carried out with 500 g. of benzyl cyanide. Under these conditions a 5-l. flask was used, and it required two and a half hours to add the benzyl cyanide. The yield of product was 325 to 370 g.

3. Other Methods of Preparation

Nitrobenzyl cyanide has hitherto been prepared by the action of fuming nitric acid¹ on benzyl cyanide.

¹ Ber. **17**, 505 (1884); **33**, 170 (1900); J. Biol. Chem. **39**, 585 (1919); J. Am. Chem. Soc. **43**, 180 (1921).

XV

p-NITROPHENYLACETIC ACID

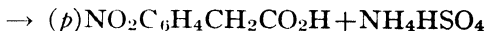
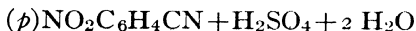

Prepared by G. R. ROBERTSON.

Checked by ROGER ADAMS and H. O. CALVERY.

1. Procedure

IN a 1-l. round-bottom flask are placed 100 g. of *p*-nitrobenzyl cyanide. A solution of 300 cc. of concentrated sulfuric acid (sp. gr. 1.84) in 280 cc. of water is prepared, and two-thirds of this solution is poured on to the *p*-nitrobenzyl cyanide. The mixture is shaken well, until the solid is all moistened with the acid. Any solid material sticking to the walls of the vessel is now washed down into the liquid with the remainder of the acid, the flask is attached to a reflux condenser, then set, without shaking, over a 10-cm. hole in a large sheet of asbestos board which rests on a tripod, and heated until the mixture boils. The boiling is continued for fifteen minutes.

The reaction mixture, which becomes rather dark, is diluted with an equal volume of cold water and cooled to 0° or below. The solution is filtered, the precipitate is washed several times with ice water and then dissolved in 1600 cc. of boiling water. (A few grams of decolorizing charcoal are added in dissolving the precipitate, if a technical *p*-nitrobenzyl cyanide has been used.) This solution is filtered as rapidly as possible through a large folded filter, preferably with a steam funnel. In spite of all precautions, however, some solid usually separates on the filter. This must be redissolved in a minimum quantity of boiling water, and this solution then filtered into the main solution. The

p-nitrophenylacetic acid separates in long, pale-yellow needles, which melt at 151–152°. The yield is 103 to 106 g. (92–93 per cent of the theoretical amount).

2. Notes

If the flask is not protected with an asbestos board or the equivalent, decomposition occurs where the substance is superheated on the side walls of the flask. If crystals of the cyanide are allowed to remain on the upper walls of the flask, they are not easily washed down and so are not hydrolyzed.

The solubility curve of *p*-nitrophenylacetic acid is very steep at temperatures near 100°, so that the filtering of the boiling solution should be rapid.

If a good grade of cyanide be used, it is not necessary to add bone-black in order to obtain the acid in a pure state.

In making experiments with 500 g. of *p*-nitrobenzyl cyanide, it was found that the time for hydrolysis was about the same as when smaller amounts were used.

3. Other Methods of Preparation

p-Nitrophenylacetic acid has been formed by the nitration of phenylacetic acid;¹ by the hydrolysis of its ester² or its amide;³ and by the hydrolysis of its nitrile with hydrochloric acid.⁴

¹ Ber. **42**, 3596 (1909).

² Ber. **12**, 1765 (1879).

³ Ber. **14**, 2342 (1881).

⁴ Ber. **15**, 834 (1882).

XVI

NITROSO- β -NAPHTHOL

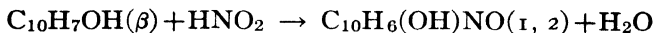

Prepared by C. S. MARVEL and P. K. PORTER.

Checked by H. T. CLARKE and W. W. HARTMAN.

1. Procedure

IN a 12-l. round-bottom flask fitted with a mechanical stirrer are placed 500 g. of technical β -naphthol dissolved in a warm solution of 140 g. of sodium hydroxide in 6 l. of water. The solution is cooled to 0° in an ice-and-salt bath, and 250 g. of powdered technical sodium nitrite is added. Stirring is started and 1100 g. of sulfuric acid (sp. gr. 1.32) are added from a dropping funnel, at such a rate that the whole is added in one to one and a half hours, the temperature being kept at 0° . During the reaction crushed ice is added from time to time to maintain the temperature at 0° ; about 1 kg. is usually used. After all of the sulfuric acid has been added, the solution should react acid to Congo paper. The mixture is stirred one hour longer at the low temperature and then the nitroso- β -naphthol, which has gradually separated out during the reaction, is filtered with suction and washed thoroughly with water. The product is at first light yellow in color, but after three to four days it gradually changes to a dark brown. The moisture content seems to have some effect on the color. After the product has been air-dried for about four days, the yield is about 665 g.; it melts at 97° . A sample of this partially dried product, on drying *in vacuo* over sulfuric acid for twenty hours, loses about 10 per cent of its weight and the melting point is 106° . By longer drying under ordinary conditions, the melting point of 106° is

reached. The total yield of dry product is about 595 g. (99 per cent of the theoretical amount).

This product is satisfactory for all purposes. It may be obtained in a crystalline condition, however, by recrystallizing from hot ligroin (sp. gr. 0.71-0.72). About 2 g. of nitroso- β -naphthol will dissolve in 15 cc. of boiling ligroin. The product is not very soluble in cold ligroin, so that nearly all is recovered.

2. Notes

It is very necessary to keep the temperature near 0° while adding the sulfuric acid, or a tarry product will be obtained. Vigorous stirring and the addition of the sulfuric acid at the proper rate are essential for a good product.

A large vessel is needed for the reaction, as the nitroso- β -naphthol separates in a finely divided condition and there is some tendency to foam.

The final air-dried product is pure except for its moisture content, as is shown by the fact that on drying *in vacuo* it has a very good melting point. A sample of Kahlbaum's nitroso- β -naphthol melted at 101-105°.

3. Other Methods of Preparation

Nitroso- β -naphthol has been made by the action of hydroxylamine hydrochloride on β -naphtho-quinone-chlorimide;¹ by the action of sulfuric acid upon a solution of potassium or sodium nitrite and the sodium salt of β -naphthol;² by the action of sodium nitrite upon an alcoholic solution of zinc chloride and β -naphthol;³ by the action of sodium nitrite upon β -naphthol suspended in zinc sulfate solution;⁴ by the action of nitrous acid on β -dinaphthol methane;⁵ and by the action of nitrosyl sulfate upon the sodium salt of β -naphthol.⁶

¹ Ber. **27**, 241 (1894).

² Ber. **8**, 1026 (1875); **27**, 3076 (1894); J. Chem. Soc. **45**, 295 (1884).

³ Ber. **18**, 705 (1885).

⁴ D. R. P. 25,469; Frdl. **1**, 335 (1883).

⁵ Ber. **33**, 806 (1900).

⁶ J. Chem. Soc. **32**, 47 (1877); Ann. **189**, 146 (1877).

XVII

PHENYLACETIC ACID



Prepared by ROGER ADAMS and A. F. THAL.

Checked by O. KAMM and A. O. MATTHEWS.

1. Procedure

IN a 5-l. round-bottom flask, fitted with a mechanical stirrer and reflux condenser, are mixed 1150 cc. of water, 840 cc. of commercial sulfuric acid and 700 g. of benzyl cyanide (preparation III, p. 9). The mixture is heated under a reflux condenser and stirred for three hours, cooled slightly and then poured into 2 l. of cold water. The mixture should be stirred so that a solid cake is not formed; the phenylacetic acid is then filtered off. This crude material should be melted under water and washed by decantation several times with hot water. These washings, on cooling, deposit a small amount of phenylacetic acid which is filtered off and added to the main portion of material. The last of the hot water is poured off from the material while it is still molten and it is then transferred to a 2-l. Claisen distilling flask and distilled *in vacuo*. A small amount of water comes over first and is rejected; about 20 cc., containing an appreciable amount of benzyl cyanide, then distils. This fraction is used in the next run. The distillate boiling 176–189°/50 mm. is collected separately and solidifies on standing. It is practically pure phenylacetic acid, m. p. 76–76.5°; it amounts to 630 g. (77.5 per cent of the theoretical amount). As the fraction which is returned to the second run of material contains a considerable portion of phenylacetic acid, the yield actually amounts to at least 80 per cent.

For the preparation of small quantities of phenylacetic acid, it is convenient to use the modified method given in the Notes.

2. Notes

The standard directions for the preparation of phenylacetic acid specify that the benzyl cyanide is to be treated with dilute sulfuric acid prepared by adding three volumes of sulfuric acid to two volumes of water. Their action, however, goes so vigorously that it is always necessary to have a trap for collecting the benzyl cyanide which is blown out of the apparatus. The use of the more dilute acid, as described in the above directions, is more satisfactory.

The phenylacetic acid may also be made by boiling under a reflux condenser for eight to fifteen hours, without a stirrer, but this method is not nearly so satisfactory as that described in the procedure.

When only small quantities of the acid are required, the following modified procedure is of value. One hundred grams of benzyl cyanide are added to a mixture containing 100 cc. of water, 100 cc. of concentrated sulfuric acid, and 100 cc. of glacial acetic acid. After this has been heated for forty-five minutes under a reflux condenser, the hydrolysis is practically complete. The reaction mixture is then poured into water, and the phenylacetic acid isolated in the usual manner.

The odor of phenylacetic acid is disagreeable and persistent.

3. Other Methods of Preparation

The standard method of preparation of phenylacetic acid is by the hydrolysis of benzyl cyanide with either alkali¹ or acid.² The acid hydrolysis runs by far the more smoothly and so was the only one studied. There are numerous other ways in which phenylacetic acid has been formed, but none of them is of practical importance for its preparation. These methods include the following: the action of water on phenyl ketene;³ the

¹ Ann. **96**, 247 (1855); Ber. **14**, 1645 (1881); Compt. rend. **151**, 236 (1910).

² Ber. **19**, 1950 (1886).

³ Ber. **44**, 537 (1911).

hydrolysis and subsequent oxidation of the product between benzaldehyde and hippuric acid;¹ the reduction of mandelic acid;² the reduction of benzoylformic acid with hydriodic acid and phosphorus;³ the hydrolysis of benzyl glyoxalidone;⁴ the fusion of atropic acid with potassium hydroxide;⁵ the action of alcoholic potash upon chlorophenylacetylene;⁶ the action of benzoyl peroxide upon phenylacetylene;⁷ the alkaline hydrolysis of triphenylphloroglucinol;⁸ the action of ammonium sulfide upon acetophenone;⁹ the heating of phenylmalonic acid;¹⁰ the hydrolysis of phenylacetoacetic ester;¹¹ the action of hydriodic acid upon mandelonitrile.¹²

¹ Ann. **370**, 371 (1909).

² Z. Chem. (2) **1**, 443 (1865); Ber. **14**, 239 (1881).

³ Ber. **10**, 847 (1877).

⁴ J. prakt. Chem. (2) **82**, 52, 58 (1910).

⁵ Ann. **148**, 242 (1868).

⁶ Ann. **308**, 318 (1899).

⁷ J. Russ. Phys. Chem. Soc. **42**, 1387 (1910); Chem. Zentr. **1911** (I) 1279.

⁸ Ann. **378**, 263 (1911).

⁹ Ber. **21**, 534 (1888); J. prakt. Chem. (2) **81**, 384 (1910).

¹⁰ Ber. **27**, 1094 (1894).

¹¹ Ber. **31**, 3163 (1898).

¹² Inaugural Dissertation of A. Kohler (1909), Univ. of Bern.

XVIII

PHENYLACETYLENE

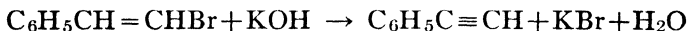

Prepared by JOHN C. HESSLER.

Checked by J. B. CONANT and E. R. BARRETT.

1. Procedure

IN a 500-cc. Pyrex distilling flask are placed 150 g. of potassium hydroxide. The mouth of the flask is provided with a one-hole stopper holding a dropping funnel; the side tube of the flask is connected with a condenser set for downward distillation. The β -bromostyrene (100 g.) is placed in the dropping funnel.

The distilling flask is gradually heated in an oil bath until the temperature of the bath is 200° , and the bromostyrene is then dropped in upon the molten potassium hydroxide, at the rate of somewhat less than a drop a second. Since the boiling point of phenylacetylene is $142\text{--}143^\circ$, and that of bromostyrene is $218\text{--}220^\circ$, the phenylacetylene distils away from the unchanged bromostyrene.

While the bromostyrene is being dropped in, the temperature of the oil bath is raised very gradually to $215\text{--}220^\circ$, and is kept at this temperature until all the bromostyrene has been added. Finally the temperature is raised to 230° , and is held there until no more distillate comes over. The distillate is colorless; it consists of two layers, the lower one being water. The upper layer is separated and dried with solid potassium hydroxide. It is then distilled. The yield of the distilled phenylacetylene, boiling at $142\text{--}144^\circ$, is 37 g. (67 per cent of the theoretical amount).

2. Notes

The potassium hydroxide usually available contains sufficient moisture so that it will liquefy at 200° . If pure dry potassium hydroxide is used, it is necessary to add a little water so that the fusion point will be lowered to the point indicated.

Toward the end of the reaction, a crust of potassium bromide may tend to cover the melted potassium hydroxide. One can break the crust by shaking the distilling flask gently, or by using a glass rod inserted through a second hole in the stopper holding the dropping funnel.

It is convenient to have such a rod or stirrer passing through a mercury seal in the stopper of the flask. An occasional turn of this stirrer breaks the crust and facilitates the operation. Mechanical stirring should not be employed, as it reduces the yield tremendously. Apparently this is because it facilitates the solution of bromostyrene in the tarry by-products and thus causes it to polymerize instead of reacting with the potassium hydroxide. A single Pyrex flask can be used for only two or three runs. The flask should be emptied while still very hot.

The yield of material can be somewhat increased by working with small lots (25 g. of bromostyrene).

3. Other Methods of Preparation

Phenylacetylene has been prepared by the elimination of carbon dioxide from phenylpropionic acid by means of phenol¹ or aniline² or by heating with barium hydroxide;³ from styrene dibromide, by heating with potassium hydroxide in alcohol;⁴ by heating β -bromo or chloro styrene with sodium ethylate or potassium hydroxide in alcohol;⁵ by passing the vapors of α -dichloroethylbenzene over hot soda lime;⁶ by the action

¹ Ber. **20**, 3081 (1887).

² Rec. trav. chim. **15**, 157 (1896).

³ Ann. **221**, 70 (1883).

⁴ Ann. **154**, 155 (1870); **235**, 13 (1886); Bull. soc. chim. **35**, 55 (1881); (3) **25**, 309 (1901).

⁵ Ann. **308**, 265 (1899); **342**, 220 (1905).

⁶ Jahresb. **1876**, 398; Gazz. chim. ital. **22** (2), 67 (1892); Bull. soc. chim. (3) **25**, 309 (1901).

of alcoholic potassium hydroxide on dibenzal-acetone tetrabromide;¹ by the action of aqueous potassium hydroxide on phenyl propargylaldehyde;² by the action of molten potassium hydroxide on β -bromo-styrene.³

¹ Ber. **39**, 4146 (1906).

² Ber. **31**, 1023 (1898).

³ J. Am. Chem. Soc. **44**, 425 (1922).

XIX

PHENYLHYDRAZINE

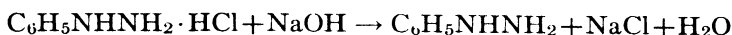
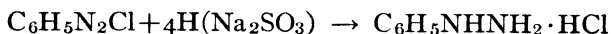
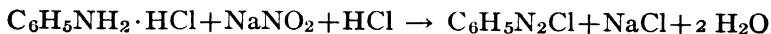

Prepared by G. H. COLEMAN.

Checked by J. B. CONANT and H. R. THOMPSON.

1. Procedure

IN a 12-l. round-bottom flask, fitted with a mechanical stirrer, are placed 1045 cc. of concentrated commercial hydrochloric acid (sp. gr. 1.138). The flask is surrounded with a freezing mixture of ice and salt, and when the contents are at 0° , stirring is started and 500 g. of cracked ice are added; then 372 g. of aniline, also cooled to 0° , are run in during five minutes. The mixture is treated with 500 g. more of cracked ice, and a cold solution (0°) of 290 g. of technical sodium nitrite dissolved in 600 cc. of water are allowed to run in slowly (twenty to thirty minutes) from a dropping funnel, the end of which is drawn to a small tip, and reaches nearly to the bottom of the flask. During this addition, the stirrer is operated rather vigorously, and the temperature is kept as near 0° as possible by the frequent addition of cracked ice (about 1 kg).

In the meantime, a sodium sulfite solution is prepared by dissolving 890 g. of sodium hydroxide, of about 90 per cent purity, in about 1 l. of water and then diluting to 6 l. A few drops of phenolphthalein solution are added and sulfur dioxide passed in, first until an acid reaction is indicated and then for two or three minutes longer. During the addition of the sulfur dioxide, the solution is cooled with running water. On account of the strong alkaline solution, the original color produced by

the phenolphthalein is very faint, but this slowly increases until it becomes deep just before the acid point is reached. It is best to remove a small sample of the liquid from time to time, dilute with three or four volumes of water and add a drop more of phenolphthalein.

The sodium sulfite solution is placed in a 12-l. flask and cooled to about 5°. Approximately 500 g. of cracked ice are added, and then, with mechanical stirring, the diazonium salt solution is run in as rapidly as possible. The mixture becomes a bright orange-red. The flask is now warmed to about 20° on a steam bath, until the solid sodium sulfite, which has separated while cooling, redissolves. The total amount of liquid is now about 10 l. One-half of this is poured into another 12-l. flask, and both halves are warmed on the steam bath to 60–70°, until the color becomes quite dark (thirty to sixty minutes). Sufficient hydrochloric acid (300–400 cc.) is now added to each flask to make the solutions acid to litmus. The heating is continued and the color gradually becomes lighter until, after four to six hours, the solutions have become nearly colorless; they may be heated overnight, if desired.

To the hot solutions are now added about one-third of their volume of concentrated hydrochloric acid (2 l. to each portion) and the mixtures cooled, first in running water, then in a freezing mixture, to 0°. The phenylhydrazine hydrochloride precipitates in the form of slightly yellowish or pinkish crystals which may be filtered off and dried.

The free base is liberated by adding to the phenylhydrazine hydrochloride 1 l. of a 25 per cent solution of sodium hydroxide. The phenylhydrazine separates and is taken up with benzene (two 300-cc. portions). The combined extractions are well dried with 200 g. of solid sodium hydroxide, poured off, and distilled. Most of the benzene may be distilled under ordinary pressure, and the remainder, and any low-boiling impurities, under diminished pressure. The pure phenylhydrazine boils at 137–138°/18 mm., and is obtained as a pale-yellow liquid. It can be crystallized on cooling in an ice bath; the crystals melt at 23°. The crude phenylhydrazine from two lots of aniline

(744 g.) is best distilled at one time and gives 695–725 g. of pure product (80–84 per cent of the theoretical amount).

2. Notes

If the sodium sulfite solution contains an excess of alkali, a black tar tends to form when the solution is warmed, and very little phenylhydrazine is obtained. Great care must be taken in determining the end point in the neutralization of the sodium hydroxide by the sulfur dioxide.

If the sodium sulfite-diazonium salt mixture is acidified before warming or before becoming dark, the red color of the solution does not disappear on heating, and the precipitated phenylhydrazine hydrochloride obtained is colored red.

The benzene solution of phenylhydrazine should be well dried before distilling, since the presence of moisture causes an increased amount of foaming to take place just after the benzene has distilled off. When the distillation is carried out carefully, practically no phenylhydrazine distils with the benzene or other low-boiling impurities.

Care should be taken that the free base contains no trace of hydrochloride since this compound catalyzes the decomposition of phenylhydrazine above 100°.

In order to obtain the maximum yield, it is necessary to cool the hydrochloric acid solution of the phenylhydrazine hydrochloride from 20° to 0°, before filtration. From 5 to 10 per cent of product separates between these two temperatures. When this is done, no more phenylhydrazine hydrochloride is obtained by concentration of the mother liquor. An increase in the amount of hydrochloric acid above 2 l. for the precipitation of the hydrochloride produces no increase in yield of product.

Most published directions for the preparation of phenylhydrazine specify the use of zinc dust and acetic acid following the reduction with sodium sulfite. No improvement in the quality or quantity of the product was obtained by using zinc and acetic acid.

It is best to use freshly prepared sodium sulfite for the

reduction, since the commercial quality is poor and gives a lower yield of phenylhydrazine. A cylinder of liquid sulfur dioxide should, of course, be available.

The rapid addition of the diazonium salt solution to the sodium sulfite seems to be advantageous.

Pure phenylhydrazine dissolves in dilute acetic acid to yield a perfectly clear solution.

The phenylhydrazine hydrochloride may be purified by crystallizing from water. A 600-cc. portion of water is used for 100 g. of crude hydrochloride, and the solution boiled a short time with a few grams of animal charcoal. After filtering, 200 cc. of concentrated hydrochloric acid are added, and the mixture cooled to 0°. Pure white crystals in a yield of 85-90 g. are obtained.

Rubber gloves should be worn when working with large quantities of phenylhydrazine, since the product may cause serious injury to the skin. The vapors of phenylhydrazine should not be inhaled.

3. Other Methods of Preparation

Phenylhydrazine has been prepared by the reduction of benzene diazonium salts with sulfites;¹ by the reduction of benzene diazonium chloride with stannous chloride;² by the reduction of benzene diazonium hydrate with zinc or sulfur dioxide;³ by the reduction of sodium benzene diazotate with sodium stannite;⁴ by the reduction of diazoamino benzene;⁵ by the reduction of nitrosophenyl hydroxylamine or its methyl ether;⁶ and by the action of hydrazine hydrate on phenol.⁷

¹ Ann. **190**, 79 (1878); Ber. **20**, 2463 (1887).

² Ber. **16**, 2976 (1883); **17**, 572, footnote (1884).

³ Ber. **31**, 346 (1898).

⁴ Ber. **36**, 816 (1903).

⁵ Ann. **190**, 77 (1878).

⁶ Ber. **31**, 582 (1898).

⁷ Ber. **31**, 2910 (1898).

XX

PHTHALIMIDE

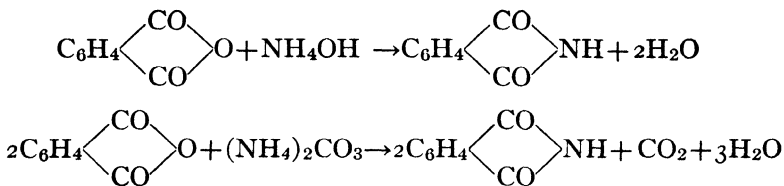

Prepared by W. A. NOYES and P. K. PORTER.
 Checked by H. T. CLARKE and J. H. BISHOP.

1. Procedure

IN a 5-l. round-bottom flask (Pyrex) is placed a mixture of 500 g. of phthalic anhydride and 400 g. of 28 per cent ammonium hydroxide. The flask is fitted with an air condenser not less than 10 mm. in diameter and is then slowly heated with a free flame until the mixture is in a state of quiet fusion at a temperature of about 300°. It requires about one hour before all the water has gone and about one and a half to two hours before the temperature of the reaction mixture reaches 300° and the mixture is a homogeneous melt. It is advisable, during the heating, to shake the flask occasionally; some material sublimes into the condenser and must be pushed down with a glass rod. The hot reaction mixture is now poured out into a crock, covered with a paper to prevent loss by sublimation, and allowed to cool. The product is practically pure without further treatment, and melts at 232–235°. The yield is 470–480 g. (94–95 per cent of the theoretical amount).

Phthalimide may also be made by using 500 g. of phthalic anhydride and 500 g. of ammonium carbonate which has been previously ground in a mortar. The subsequent procedure is

the same as when aqueous ammonia is used. Frequent shaking is necessary, and the sublimed material must be occasionally pushed back into the reaction flask. About two hours are required for completion.

2. Notes

Several smaller runs of 25 g. of phthalic anhydride gave the same percentage yield.

Phthalimide may be recrystallized from water, but only about 4 g. of phthalimide will dissolve in a liter of boiling water. It may also be crystallized from alcohol, in which solvent it dissolves to the extent of five parts in a hundred at boiling temperature.

On a large scale, it would be advisable to collect the small amount of ammonia given off during the reaction.

If desired, the product obtained by pouring the reaction mass into the crock may be treated with hot water to soften the cake, broken up with a glass rod, transferred to a flask and boiled with water for a few minutes. This treatment, however, is quite unnecessary; for all practical purposes, the crude cake, as it is obtained, may be ground up and used directly.

3. Other Methods of Preparation

Phthalimide has been formed by heating ammonium phthalate;¹ by heating acid ammonium phthalate;² by passing dry ammonia over heated phthalic anhydride;³ by treating phthalyl chloride with dry ammonia;⁴ by heating phthalamide;⁵ by heating phthalic anhydride with ammonium thiocyanate;⁶ by heating phthalic anhydride with urea;⁷ by heating phthalic

¹ Jahresb. 1868, 549; Ann. 19, 47 (1836); 41, 110 (1842); 42, 220 (1842); 205, 300 (1880); 215, 181 (1882).

² Jahresb. 1847-1848, 590.

³ Am. Chem. J. 3, 29 (1881).

⁴ Am. Chem. J. 3, 28 (1881).

⁵ Ber. 39, 2278 (1906).

⁶ Ber. 19, 1398 (1886).

⁷ Ber. 10, 1166 (1877); Am. Chem. J. 18, 333 (1896); J. Am. Chem. Soc. 32, 116 (1910); Z. angew. Chem. 32, I, 301 (1919).

anhydride with ammonium carbonate;¹ by heating phthalic acid with nitriles;² by fusing *o*-cyanobenzoic acid;³ and by the action of potash on *o*-cyanobenzaldehyde.⁴

Of these, the first three are the only ones which need be considered as methods for the preparation of phthalimide. It was found that the third was by no means easy to bring about: dry phthalic anhydride is apparently only superficially affected by the dry ammonia, and it was difficult to introduce sufficient heat into the loose mass of crystals to cause the reaction to start.

¹ J. Am. Chem. Soc. **42**, 1282 (1920).

² J. Am. Chem. Soc. **18**, 680 (1896); **20**, 654 (1898).

³ Rec. trav. chim. (1) **11**, 93 (1892).

⁴ Ber. **30**, 1698 (1897).

XXI

QUINOLINE

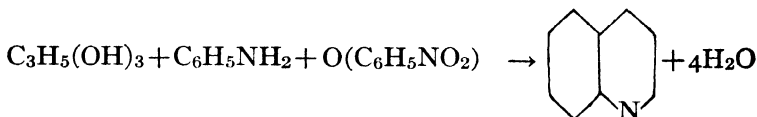

Prepared by H. T. CLARKE and ANNE W. DAVIS.
Checked by ROGER ADAMS and A. W. SLOAN.

1. Procedure

IN a 5-l. round-bottom flask, fitted with an efficient reflux condenser of wide bore, are placed, in the following order, 80 g. of powdered crystalline ferrous sulfate, 865 g. of glycerol (c. p.), 218 g. of aniline, 170 g. of nitrobenzene, and 400 cc. of concentrated sulfuric acid (sp. gr. 1.84). The contents of the flask are well mixed and the mixture heated gently over a free flame. As soon as the liquid begins to boil, the flame is removed, since the heat evolved by the reaction is sufficient to keep the mixture boiling for one-half to one hour. If the reaction proceeds too violently at the beginning, the reflux condenser may be assisted by placing a wet towel over the upper part of the flask. When the boiling has ceased the heat is again applied and the mixture boiled for five hours. It is then allowed to cool to about 100° and transferred to a 12-l. flask; the 5-l. flask is rinsed out with a small quantity of water. The 12-l. flask is then connected with the steam-distillation apparatus shown in Fig. 3, a 12-l. flask being used as a receiver; steam is passed in (without external heat) until 1500 cc. have distilled (ten to thirty minutes). This removes all the unchanged nitrobenzene (10-20 cc.). The current of steam is then interrupted, the receiver is changed, and 1500 g. of 40 per cent sodium hydroxide solution are added cautiously through the steam inlet. The heat of neutrali-

zation is sufficient to cause the liquids to boil and thus become thoroughly mixed. Steam is then passed in as rapidly as possible until all the quinoline has distilled. In this process, 6-8 l. of distillate are collected (two and a half to three and a half hours are required, unless a very efficient condensing apparatus is used, under which conditions the distillation may be complete in one-half to one and a half hours). The distillate is allowed to cool, and the crude quinoline separated. The aqueous layer of the distillate is again distilled with steam

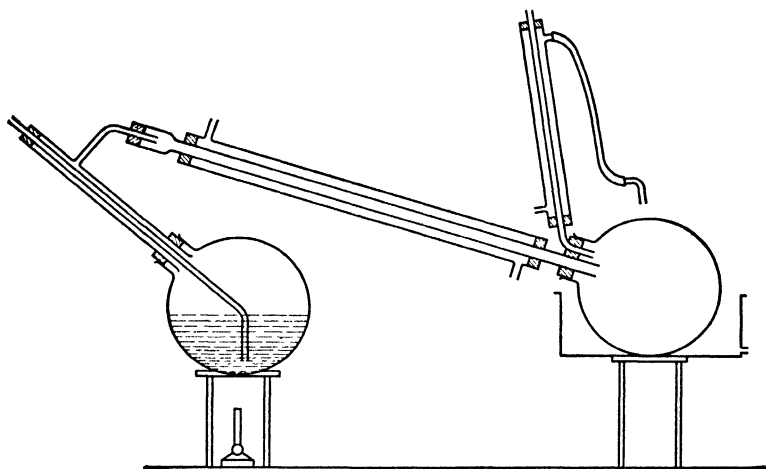

FIG. 3.

until all the quinoline has been volatilized and collected in about 3 l. of distillate.

These 3 l. of distillate are then mixed with the first yield of quinoline and 280 g. (150 cc.) of concentrated sulfuric acid are added. The solution is cooled to $0-5^{\circ}$, and a saturated solution of sodium nitrite added until a distinct excess of nitrous acid is present (as shown either by starch-potassium iodide paper or by the odor). This generally requires 50 to 70 g. of sodium nitrite. The mixture is then warmed on a steam bath for an hour, or until active evolution of gas ceases, and is then distilled with steam until all the volatile material has been expelled (4 l. of

distillate will result). The receiver is then changed and the mixture in the distillation flask is neutralized, as before, with 700 g. of 40 per cent sodium hydroxide solution. The quinoline is distilled exactly as described above, the aqueous portions of the distillate being distilled with steam until all the quinoline has been isolated. The crude product is then distilled under reduced pressure, and the fraction which boils at $110-114^{\circ}/14$ mm. is collected. The foreruns are separated from any water which may be present, dried with a little solid alkali, and redistilled. The total yield is 255-275 g. (84-91 per cent of the theoretical amount based on the aniline taken).

2. Notes

Although these directions have been used many times with results exactly as described, in a few cases the yields have dropped to 60-65 per cent without any apparent reason. At present no explanation can be given for this.

In the Skraup synthesis of quinoline the principal difficulty has always been the violence with which the reaction generally takes place; it occasionally proceeds relatively smoothly, but in the majority of cases gets beyond control, with consequent loss of material through the condenser. By the addition of ferrous sulfate, which undoubtedly functions as an oxygen carrier, the reaction is extended over a longer period of time. It is thus possible to work with much larger quantities of material when ferrous sulfate is employed.

It is important that the materials should be added in the correct order; should the sulfuric acid be added before the ferrous sulfate, the reaction may start at once. It is also important to mix the materials well before applying heat; the aniline sulfate should have dissolved almost completely and the ferrous sulfate should be distributed throughout the solution. To avoid danger of overheating, it is well to apply the flame away from the center of the flask where any solids would be liable to congregate.

In the apparatus for steam distillation, the greater portion of the condensation is effected by the stream of water passing over

the receiver. It is, therefore, necessary that the stream passing through the condenser should be sufficiently rapid to cause it to form a uniform film over the receiving flask. A 12-l. flask is even more efficient as a condenser than the 5-l. flask. It is important that the tube through which the vapors leave the distillation flask should be neither too short nor, especially, too narrow. Where the external diameter of the steam inlet tube is 5-8 mm., the internal diameter of this steam head should be not less than 28 mm. Were it less, the current of steam passing through it would be so rapid as to prevent small quantities of liquid from returning to the flask, and these would be driven over into the receiver.

Much time can be saved by the use of the steam distillation apparatus described, especially when large quantities have to be handled. The above directions avoid the use of extraction methods, which not only consume more time but may lead to appreciable losses of material. If the downward condenser is of iron, the apparatus is even more efficient and the time for the steam distillation is halved.

The percentage yields have been based on the amount of aniline taken. It would probably be more legitimate to base the calculation on the amounts of aniline taken and of nitrobenzene not recovered, since undoubtedly the latter is reduced to aniline during the course of the reaction. If this be done, the yield is found to be only 55 to 60 per cent of the calculated amount.

In a number of experiments, the glycerol used contained an appreciable amount of water. Under these conditions, the yield of product is much lower. "Dynamite" glycerol containing less than half a per cent of water is best employed; U. S. P. glycerol contains 5 per cent of water and usually gives lower yields.

3. Other Methods of Preparation

Quinoline has been produced by passing the vapor of allylaniline over red-hot lead oxide;¹ by heating acrylideneaniline, or better, a mixture of aniline, glycerol and sulfuric acid;² by

¹ Ber. **12**, 453 (1879).

² Ber. **13**, 911 (1880); Monatsh. **1**, 316 (1880).

heating aniline with glycerol and sulfuric acid, using nitrobenzene as an oxidizing agent;¹ by treating a mixture of glyoxal and *o*-toluidine with alkali;² by treating a solution of *o*-aminobenzaldehyde with acetaldehyde and alkali;³ by heating methylacetanilide with zinc chloride;⁴ by heating aminoazobenzene with glycerol and sulfuric acid;⁵ by heating a mixture of aniline, glycerol and sulfuric acid with arsenic acid.⁶

Of the above methods, the only ones which need be considered are those in which a mixture of aniline, glycerol and sulfuric acid is heated with an oxidizing agent. With the use of nitrobenzene, the reaction, according to the original method, takes place with extreme violence.

The method above described is the most satisfactory for the preparation of quinoline itself, but for the preparation of homologues of quinoline, the use of arsenic acid is preferable, since the yields are somewhat greater.

Since the work was carried out, a method has been published⁷ in which aniline, glycerol and sulfuric acid are treated with ferric oxide. By this method Adams and Parks were unable to obtain yields comparable with those resulting from the above directions.

¹ Monatsh. **2**, 141 (1881); J. prakt. Chem. (2) **49**, 549 (1894).

² Monatsh. **15**, 277 (1894).

³ Ber. **15**, 2574 (1882); **16**, 1833 (1883).

⁴ Ber. **23**, 1903 (1890).

⁵ Ber. **24**, 2623 (1891).

⁶ Ber. **29**, 704 (1896).

⁷ Chem. News **121**, 205 (1920).

XXII

QUINONE

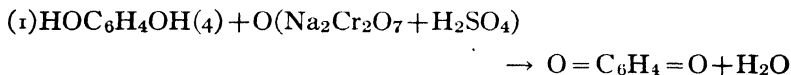

Prepared by E. B. VLIET.

Checked by ROGER ADAMS and I. E. DREGER.

1. Procedure

IN a 2.5-l. beaker, 100 g. of hydroquinone are dissolved in 2000 cc. of water heated to about 50°. After the solid is completely dissolved, the solution is cooled to 20°, 100 g. of concentrated sulfuric acid are slowly poured in, and the mixture is again cooled to 20°. A concentrated solution of technical sodium dichromate is prepared by dissolving 140 g. in 65 cc. of water. This solution is then added gradually to the hydroquinone solution, with the use of a mechanical stirrer (see notes), the mixture being cooled so that the temperature never rises above 30°. At first a greenish-black precipitate forms, but upon further addition of the sodium dichromate solution, the color changes to yellowish green. As soon as this color remains permanent (a slight excess of sodium dichromate does no harm) the reaction is complete. This requires about one-half to three-quarters of an hour; 90 to 110 cc. of sodium dichromate solution is necessary. The mixture is then cooled to about 10° and filtered with suction. As much water as possible is pressed out of the crystals.

The filtrate is extracted twice, 150 cc. of benzene being used for each extraction. The precipitate of quinone is transferred to a 1-l. beaker, and 500 cc. of benzene, including the 300 cc. used to extract the filtrate, are added. The mixture is now

heated with stirring on a steam-bath, and as soon as most of the quinone has dissolved the benzene layer is decanted into another beaker. It is dried while hot by stirring a short time with a little calcium chloride, and then filtered through an ordinary funnel into a 1-l. distilling flask before it cools. There is a certain amount of quinone which does not go into the 500 cc. of benzene, so that the residue is extracted a second time with about 100 cc. of benzene, which is dried and filtered with the first extract. During these extractions, the benzene should not be at the boiling point, as this will cause a considerable volatilization of the quinone.

The distilling flask is now attached to a condenser set for downward distillation, and the benzene is distilled. As soon as the quinone starts to separate, the residue in the flask is transferred to a beaker and cooled in an ice bath. The precipitate is filtered off with suction and the product spread out for a short time to dry. The product is yellow in color and weighs 75 to 80 g. (76-81 per cent of the theoretical amount). Material made in this way will hold its yellow color over long periods of time, provided it is protected from light.

The benzene distillate is yellow and contains some quinone. This, as well as the benzene from the final filtration of the quinone crystals, may be used in a subsequent run and thus raises the yield of the subsequent runs to about 85-90 g. (85-90 per cent of the theoretical amount).

2. Notes

As the mixture becomes thick during the oxidation, it is very necessary to use a stirrer which will keep the whole mass agitated by reaching to the sides and bottom of the beaker.

If impure hydroquinone is used, a black, sticky precipitate will usually appear after the addition of the sulfuric acid to the hydroquinone solution. This should be removed, before the oxidation is started, by filtration without suction through a fluted filter.

When technical sodium dichromate is used, the solution

should be filtered with suction, before it is added to the hydroquinone, in order to remove any insoluble impurities.

In the laboratory it is convenient to make several small runs of the size indicated, as far as the oxidation is concerned; but the benzene extractions can be combined.

It is also possible to obtain good yields of quinone in the following manner: 1500 cc. of water, 465 g. of concentrated sulfuric acid and 300 g. of hydroquinone are mixed in a 3-l. beaker. The mixture is cooled to 0° , and 330 g. of sodium dichromate are added in powdered form, the temperature being kept below 5° at all times. This procedure requires a longer time and much more care in the control of conditions than the method described above.

3. Other Methods of Preparation

Quinone may be prepared by the oxidation of aniline with dichromate or manganese dioxide and sulfuric acid.¹ This is a more feasible commercial method than the one given. However, the oxidation of hydroquinone is more rapid and convenient and, hence is more desirable for use in the laboratory. Various materials have been oxidized by chemical means to give quinone: they are quinic acid,² hydroquinone,³ benzidine,⁴ *p*-phenylenediamine,⁵ sulfanilic acid,⁶ *p*-phenolsulfonic acid,⁷ arbutin,⁸ aniline black,⁹ and the leaves of various plants.¹⁰ Quinone is also formed by several other methods: by the fermentation of fresh grass;¹¹ by the action of iodine on the lead salt of hydroquin-

¹ Jahresb. **1863**, 415; Ber. **10**, 1934, 2005 (1877); **16**, 687 (1883); **19**, 1468 (1886); **20**, 2283 (1887); **31**, 1524 (1898); Ann. **200**, 240 (1880); **215**, 127 (1882).

² Ann. **27**, 268 (1838).

³ Ann. **51**, 152 (1844); Am. Chem. J. **14**, 555 (1892).

⁴ Jahresb. **1863**, 415.

⁵ Jahresb. **1863**, 422.

⁶ Ann. **159**, 7 (1871); Ber. **8**, 760 (1875).

⁷ Ber. **8**, 760 (1875).

⁸ Ann. **107**, 233 (1858).

⁹ Ber. **10**, 1934 (1877); **34**, 1285 (1901).

¹⁰ Ann. **89**, 247 (1854); Ber. **34**, 1162 (1901).

¹¹ Ber. **30**, 1870 (1897).

one;¹ by the decomposition of the compound, $C_6H_4 \cdot 2CrO_2Cl$ with water;² by the action of sulfuric acid on phenol blue;³ by the electrochemical oxidation of aniline,⁴ hydroquinone⁵ or benzene;⁶ by the catalytic oxidation of benzene.⁷

¹ Ber. **31**, 1458 (1898); Am. Chem. J. **26**, 20 (1901).

² Ann. chim. phys. (5) **22**, 270 (1881).

³ Ber. **18**, 2915 (1885); **21**, 889 (1888).

⁴ D. R. P. 109,012; Frdl. **5**, 664 (1900); D. R. P. 117,129; Frdl. **6**, 112 (1901); J. Soc. Dyers and Colourists, **36**, 138 (1920).

⁵ D. R. P. 117,129; Frdl. **6**, 112 (1901).

⁶ D. R. P. 117,251; Frdl. **6**, 109 (1901); U. S. Pat. 1,322,580 (1919); C. A. **14**, 287 (1920); Rev. produits chim. **21**, 219 (1918); **21**, 288 (1918).

⁷ U. S. Pat. 1,318,631 (1919); C. A. **14**, 70 (1920).

XXIII

SODIUM *p*-TOLUENESULFINATE

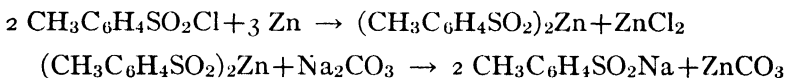

Prepared by FRANK C. WHITMORE and FRANCIS H. HAMILTON
Checked by J. B. CONANT and PAUL ALLEN, JR.

1. Procedure

FIVE HUNDRED grams of technical *p*-toluenesulfonyl chloride are ground in a mortar to break up all lumps. Three liters of water are placed in a 12-l. crock provided with a large brass stirrer and a tube for passing steam directly into the liquid. Dry steam is passed into the water until the temperature reaches 70°. The steam is then shut off and 400 g. of zinc dust (90 to 100 per cent pure) is added. The sulfonyl chloride is then added in small portions by means of a porcelain spoon. The addition takes about ten minutes. The temperature rises to about 80°. Stirring is continued for ten minutes after the last of the chloride has been added. Steam is then passed into the mixture until the temperature reaches 90°. If it is heated any hotter, bumping takes place. The steam is shut off, and 250 cc. of 12 *N.* sodium hydroxide solution is added. Finely powdered sodium carbonate is then added in 50-g. portions until the mixture is strongly alkaline. The mixture froths considerably, but this causes no trouble unless too small a crock is used. The stirrer is loosened and the crock is removed. The mixture is filtered by suction in a large funnel. The filtrate has a volume of about 4.5 l. The cake of unchanged zinc dust and zinc compounds is transferred to a 3-l. battery jar and placed under the stirrer, and the latter is clamped in place. Water (750 cc.) is added,

the stirrer is started, and steam is passed in until the mixture starts to froth too violently. The steam is then shut off, but the stirring is continued for ten minutes. The mixture is filtered and the filtrate is added to the main solution in a large evaporating dish. The liquid is evaporated over a large burner to a volume of about 1 l., or until a considerable crust forms around the edges. The mixture is then cooled. Large, flat, transparent crystals separate. The thoroughly cooled mixture is filtered by suction, and the crystals are air-dried until efflorescence just starts. They are then bottled. The product is $\text{CH}_3\text{C}_6\text{H}_4\text{SO}_2\text{Na} \cdot 2\text{H}_2\text{O}$. Yield 360 g. (64 per cent of the theoretical amount). Careful acidification of the mother liquor with dilute hydrochloric acid yields 15 g. of the free sulfinic acid.

2. Notes

The free sulfinic acid may be prepared by dissolving the sodium salt in cold water and carefully acidifying the solution with hydrochloric acid. An excess of the latter must be avoided, as it dissolves the acid to a certain extent. The sulfinic acid is difficult to dry without partial conversion into the sulfonic acid.

3. Other Methods of Preparation

Toluenesulfinic acid and its salts have been prepared by three general methods: (1) The reduction of the sulfonyl chloride. The reagents which have been used for this are sodium amalgam,¹ zinc dust in alcohol or water,² sodium sulfite,³ sodium sulfide,⁴ potassium hydrosulfide⁵ (the thio acid being first formed) and sodium arsenite.⁶ (2) From toluene by the Friedel and Crafts reaction, using either sulfur dioxide and hydrogen chloride⁷ or sulfonyl chloride.⁸ (3) From *p*-toluidine by diazotization and

¹ Ann. **142**, 93 (1867).

² Ber. **9**, 1586 (1876).

³ Ber. **3**, 965 (1870).

⁴ D. R. P. 224,019; Chem. Zentr. **1910**, (II), 513.

⁵ Ber. **42**, 3821 (1909).

⁶ Ber. **41**, 3351 (1908); Ber. **42**, 480 (1909).

⁷ Ber. **41**, 3318 (1908); J. Chem. Soc. **93**, 754 (1908).

⁸ Rec. trav. chim. (2) **30**, 381 (1911).

subsequent treatment with sulfur dioxide and finely divided copper.¹ The compound has also been obtained in certain reactions which, however, would not be suitable for preparative work; thus it is formed by hydrolysis and reduction of certain thio derivatives² prepared from the acid itself and also by the decomposition of ditolylsulfonmethylamine.³

¹ Ber. **32**, 1141 (1899); J. Chem. Soc. **95**, 344 (1909).

² Ber. **15**, 130 (1882); **20**, 2088 (1887); **41**, 3351 (1908).

³ J. prakt. Chem. (2) **63**, 170 (1901).

XXIV

1, 3, 5-TRINITROBENZENE

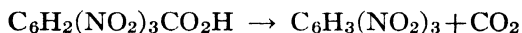

Prepared by H. T. CLARKE and W. W. HARTMAN.
Checked by J. B. CONANT and J. J. TOOHY.

1. Procedure

THE crude trinitrobenzoic acid obtained by oxidation of 360 g. of trinitrotoluene (prep. XXV, p. 95) is mixed with 2 l. of water at 35° in a 5-l. flask provided with a stirrer. Fifteen per cent sodium hydroxide solution is added, with continuous stirring, until a *faint* red color is just produced. (See Notes.) The color is then immediately discharged by means of one or two drops of acetic acid, and the liquid is filtered from unchanged trinitrotoluene. The filtrate is transferred to a 5-l. flask, and 70 cc. of glacial acetic acid are added. The mixture is then gently heated, with continuous stirring, when trinitrobenzene separates in crystalline condition, and floats on the surface of the liquid as a frothy layer. After about one and a half hours the evolution of gas ceases; at this point the crystals begin to stir into the solution. The heating and stirring is continued for three-quarters of an hour, when the mixture is allowed to cool, and the crystals filtered off. A sample of the filtrate should be tested for undecomposed trinitrobenzoic acid: if a precipitate is produced by the addition of sulfuric acid the process must be continued. After recrystallization from glacial acetic acid, the product melts at 121–122°. The yield is 145–155 g. (43 to 46 per cent of the theoretical amount calculated from the trinitrotoluene).

2. Notes

During the solution of the trinitrobenzoic acid, the temperature should not be below 35° , owing to the slight solubility of trinitrobenzoic acid in cold water. The heat of neutralization raises the temperature to $45-55^{\circ}$, but the latter temperature should not be exceeded, since any trinitrobenzene formed at this point would later be removed with the unreacted trinitrotoluene.

Care must be taken that no more alkali is added than is just sufficient to produce the faint red color. If an excess of alkali is added it produces a permanent color, which is not removed by acid and colors the final product.

When once the evolution of carbon dioxide sets in, the flame must be cut down so as to avoid the formation of a thick layer of froth which might foam over.

3. Other Methods of Preparation

1, 3, 5-Trinitrobenzene can be prepared by heating *m*-dinitrobenzene with nitric acid and sulfuric acid to 120° ;¹ by heating 2, 4, 6-trinitrotoluene with fuming nitric acid in a sealed tube at 180° for three hours;² by heating 2, 4, 6-trinitrobenzoic acid or its sodium salt with water, alcohol, dilute sodium carbonate or other suitable solvent.³

¹ Ber. **9**, 402 (1876); Ann. **215**, 344 (1882).

² Ber. **16**, 1596 (1883).

³ D. R. P. 77,353; Frdl. **4**, 34 (1894).

XXV

2, 4, 6-TRINITROBENZOIC ACID

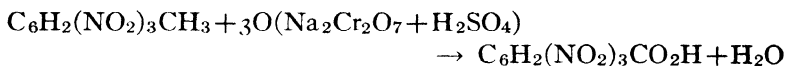

Prepared by H. T. CLARKE and W. W. HARTMAN.
Checked by J. B. CONANT and J. J. TOOHY.

1. Procedure

To 3600 g. of concentrated sulfuric acid, in a 5-l. flask placed in an empty water bath, are added 360 g. of technical trinitrotoluene, while the mixture is stirred mechanically. Sodium dichromate ($\text{Na}_2\text{Cr}_2\text{O}_7 \cdot 2 \text{H}_2\text{O}$) is now added in small quantities (*precaution*: see Notes), with constant stirring, until the temperature of the mixture reaches 40° ; the empty water bath is now filled with cold water and the addition of sodium dichromate continued at such a rate that the temperature remains at $45\text{--}55^\circ$. In all 540 g. of sodium dichromate are added, the addition taking one to two hours. When all has been added, the mixture, which has now become very thick, is stirred for two hours at $45\text{--}55^\circ$, and poured into a crock containing 4 kg. of crushed ice. The insoluble trinitrobenzoic acid is filtered off, and carefully washed with cold water until free from chromium salts. On drying it weighs 320–340 g.

The product is now mixed with 2 l. of distilled water at 35° in a 5-l. flask provided with a stirrer, and 15 per cent sodium hydroxide solution is dropped in with continuous stirring until a *faint* red color is just produced. Should this disappear, it is restored by the addition of a few drops more. When it has persisted for five minutes, the color is discharged by the addition of a few drops of acetic acid, and the insoluble unattacked trinitrotoluene filtered off and washed with a little water. The trinitrobenzoic acid is precipitated from the filtrate by the

addition of a slight excess of 50 per cent sulfuric acid. The solution is chilled, and the acid filtered and washed free from salts with ice water. When dried in air it weighs 230-280 g. (57 to 69 per cent of the theoretical amount).

2. Notes

The mother liquors and washings lose carbon dioxide on boiling, and the insoluble trinitrobenzene separates (see preparation XXIV); after filtering, washing, and drying, it weighs 15-20 g. (4 to 6 per cent of the theoretical amount).

It is essential that the stirring should be most efficient, so that when the mixture becomes thick the dichromate will be evenly distributed throughout the liquid, as rapidly as it is added. If the stirring is not efficient, local reactions of extreme violence (in certain cases leading to conflagration) will occur. An iron stirrer may be employed in the oxidation reaction, but not in the purification.

Technical sodium dichromate generally contains a certain amount of chlorides, and the chlorine liberated from these tends to cause a troublesome foam towards the end of the reaction. Only a very efficient stirrer, which draws down the surface of the liquid, is able to combat this difficulty. The amount of solid sodium dichromate given is for the dry crystalline compound containing two molecules of water of crystallization.

Great care should be taken in dissolving the crude acid in the alkali. If an excess of alkali persists for any length of time, a permanent color is produced which will discolor the final product. The acid is fairly soluble in cold water and should be washed with care.

3. Other Methods of Preparation

2, 4, 6-Trinitrobenzoic acid has been prepared by heating trinitrotoluene with fuming acid in a sealed tube to 100°, for two weeks,¹ the oxidation being only partial. It can also be prepared by heating trinitrotoluene under a reflux condenser, with a mixture of 5 parts of concentrated nitric acid and 10

¹ Ber. 3, 223 (1870).

parts of concentrated sulfuric acid;¹ this method is, however, unsuitable in the laboratory owing to the difficulty of devising suitable apparatus. Another method is to dissolve trinitrotoluene in nitric acid, and, to this solution (at 95°), to add potassium chlorate at such a rate that the temperature does not fall;² this method has been found to be difficult to control on a laboratory scale.

The method described above is a modification of a patented process,³ in which trinitrotoluene suspended in sulfuric acid is treated with chromic anhydride.

¹ D. R. P. 77,559; Frdl. 4, 34 (1894).

² D. R. P. 226,225; Frdl. 10, 167 (1910).

³ D. R. P. 127,325; Frdl. 6, 148 (1901).

INDEX

A

Acetic acid, 18, 33, 64
Acetone, 41
Acetophenone, 1
Ammonium carbonate, 75
Ammonium hydroxide, 37, 75
Aniline, 71, 79
Anthranilic acid, 47

B

Benzalacetophenone, 1-3
Benzaldehyde, 1, 5
Benzoic acid, 5
Benzyl alcohol, 5
Benzyl benzoate, 5-8
Benzyl chloride 9
Benzyl cyanide, 9-11, 27, 57, 63
Bromostyrene, 67

C

Carbon tetrachloride, 23
Chlorine, 37
Copper sulfate, 38

D

Dibenzyl ether, 6
 α , γ -Dichloroacetone, 13-15
Dimethylaminobenzaldehyde, 17-21
Dimethylaniline, 17, 47

E

Ethyl alcohol, 23, 27
Ethyl oxalate, 23-26
Ethyl phenylacetate, 27-28

F

Ferrous sulfate, 79
Formaldehyde, 17

G

Gelatine solution, 37
Glycerol, 29, 33, 79
Glycerol α , γ -dichlorohydrin, 29-31
Glycerol α -monochlorohydrin, 33-35

H

Hydrazine sulfate, 37-40
Hydrochloric acid, 17, 30, 34, 47, 71
Hydroquinone, 85

M

Mesitylene, 41-45
Methyl red, 47-51

N

Naphthol, 61
Nitric acid, 57
Nitrobenzene, 79
p-Nitrobenzoic acid, 53-55
p-Nitrobenzyl cyanide, 57-58, 59
p-Nitrophenylacetic acid, 59-60
Nitrosodimethylaniline hydrochloride,
17
Nitroso- β -naphthol, 61-62
Nitrotoluene, 53

O

Oxalic acid, 23

P

Phenylacetic acid, 10, 63-65
Phenylacetylene, 67-69

Phenylhydrazine, **71-74**
Phthalic anhydride, 75
Phthalimide, **75-78**
Potassium hydroxide, 67

Q

Quinoline, **79-83**
Quinone, **85-88**

S

Sodium acetate, 48
Sodium benzylate, 6
Sodium cyanide, 9
Sodium dichromate, 13, 53, 85, 95
Sodium hydroxide, 1, 37, 61, 93
Sodium hypochlorite, 37
Sodium, metallic, 5, 42

Sodium nitrite, 17, 47, 61, 71, 80
Sodium sulfite, 71
Sodium *p*-toluene sulfinate, **89-91**
Sulfur dioxide, 71
Sulfuric acid, 13, 27, 30, 34, 37, 41, 43,
53, 57, 59, 63, 79, 85, 95

T

Toluene, 48
Toluenesulfonyl chloride, 89
1, 3, 5-Trinitrobenzene, **93-94**, 96
2, 4, 6-Trinitrobenzoic acid, 93, **95-97**
2, 4, 6-Trinitrotoluene, 93, 95

Z

Zinc dust, 89

