

UNIVERSAL
LIBRARY

OU | **152688**

UNIVERSAL
LIBRARY

OSMANIA UNIVERSITY LIBRARY

Call No. *532.5/AMS1P* Accession No. *32937*

Author *American Mathematical*

Title *Fluid Dynamics 1953*

This book should be returned on or before the date last marked below.

PROCEEDINGS OF
SYMPOSIA IN APPLIED MATHEMATICS
VOLUME IV

FLUID DYNAMICS

McGRAW-HILL BOOK COMPANY, INC.

NEW YORK TORONTO LONDON

1953

FOR THE AMERICAN MATHEMATICAL SOCIETY

80 WATERMAN STREET, PROVIDENCE, RHODE ISLAND

PROCEEDINGS OF THE
FOURTH SYMPOSIUM IN APPLIED MATHEMATICS
OF THE AMERICAN MATHEMATICAL SOCIETY

Held at the University of Maryland
June 22-23, 1951

COSPONSORED BY
THE U.S. NAVAL ORDNANCE LABORATORY

M. H. Martin
EDITOR

EDITORIAL COMMITTEE

R. V. Churchill
Eric Reissner
A. H. Taub

Copyright, 1953, by the McGraw-Hill Book Company, Inc. Printed in the
United States of America. All rights reserved. This book, or parts thereof,
may not be reproduced in any form without permission of the publishers.

Library of Congress Catalog Card Number: 52-10326

CONTENTS

EDITOR'S PREFACE	v
Some Aspects of the Statistical Theory of Turbulence	1
BY S. CHANDRASEKHAR	
A Critical Discussion of Similarity Concepts in Isotropic Turbulence	19
BY C. C. LIN	
The Nonexistence of Transonic Potential Flow	29
BY ADOLF BUSEMANN	
On Waves of Finite Amplitude in Ducts (Abstract)	41
BY R. E. MEYER	
On the Problem of Separation of Supersonic Flow from Curved Profiles	47
BY T. Y. THOMAS	
On the Construction of High-speed Flows	55
BY G. F. CARRIER AND K. T. YEN	
An Example of Transonic Flow for the Tricomi Gas	61
BY M. H. MARTIN AND W. R. THICKSTUN	
On Gravity Waves	75
BY A. E. HEINS	
Hydrodynamics and Thermodynamics	87
BY S. R. DE GROOT	
Nonuniform Propagation of Plane Shock Waves	101
BY J. M. BURGERS	
Theory of Propellers	109
BY THEODORE THEODORSEN	
Numerical Methods in Conformal Mapping	117
BY G. BIRKHOFF, D. M. YOUNG, AND E. H. ZARANTONELLO	
Flow of Viscous Liquid through Pipes and Channels	141
BY J. L. SYNGE	
The Method of Singularities in the Physical and in the Hodograph Plane	167
BY ALEXANDER WEINSTEIN	
INDEX	179

EDITOR'S PREFACE

This volume contains the papers which were presented at the Fourth Symposium in Applied Mathematics of the American Mathematical Society held at the University of Maryland on June 22 and 23, 1951. The subject of the Symposium was *Fluid Dynamics*, and the four sessions were devoted to *Turbulence*, *Compressible Flow*, *Foundations*, and *Incompressible Flow*. The Symposium was cosponsored by the U.S. Naval Ordnance Laboratory, White Oak, Maryland.

One of the papers appears as an abstract, due to prior arrangements for publication, and carries a reference to the complete paper. Another appears in this volume although circumstances beyond our control prevented the author from delivering it at the time of the Symposium.

All who participated in the Symposium are indebted to the McGraw-Hill Book Company, Inc., which, beginning with the Proceedings of the Symposium on Elasticity, has undertaken in these uncertain times the task of bringing the Proceedings of these Symposia on Applied Mathematics to the scientific public in book form.

The Editor gratefully acknowledges the invaluable help afforded by the Committee on Arrangements consisting of W. Leutert, H. Polachek, R. J. Seeger, J. H. Taylor, J. L. Vanderslice, A. Weinstein, and W. M. Whyburn. He is also indebted to R. V. Churchill, J. B. Diaz, and R. M. Davis for help in the editorial work.

Particular thanks are also due to the Mathematical Sciences Division of the Office of Naval Research for their aid in bringing a number of our colleagues, who participated on the program, to the Symposium.

M. H. MARTIN

Editor

SOME ASPECTS OF THE STATISTICAL THEORY OF TURBULENCE

BY

S. CHANDRASEKHAR

1. Isotropic tensors and the equations of isotropic turbulence. The central idea in the statistical theory of homogeneous isotropic turbulence initiated by G. I. Taylor [1] is that of isotropy, which requires the time average of any function of the velocity components, defined with respect to a particular set of axes, to be invariant under arbitrary rotations and reflections of the axes of reference. A phenomenological theory of turbulence incorporating this idea of isotropy divides itself into two parts: a *kinematical* part, which consists in setting up correlations between velocity components at two different points of the medium and in reducing the forms of the associated tensors to meet the requirements of isotropy; and a *dynamical* part, which consists in deriving the consequences of the equations of motion and continuity for the fundamental scalar functions defining the correlation tensors. When dealing with turbulence in an incompressible fluid, it is convenient to include in the kinematical part the restrictions on the correlation tensors introduced by the equation of continuity and to reserve for the dynamical part alone the implications of the Stokes-Navier equation. The principal equations of this theory were derived by von Kármán and Howarth [2], but a concise and elegant treatment of the subject is due to H. P. Robertson [3], who developed for this purpose a theory of *isotropic tensors and forms*. The basic idea underlying this new formal development can be explained quite simply.

Consider the fundamental correlation tensor

$$(1) \quad Q_{ij} = \overline{u_i u_j}$$

of the components u_i and u_j' of the velocity at two different points, say, $P(x_i)$ and $P'(x_i')$ in the medium. Let ξ denote the vector joining the points x_i and x_i' , that is, $\xi_i = x_i' - x_i$. The correlation $\overline{u_a u_b'}$ of the velocities along two directions specified by the unit vectors \mathbf{a} at P and \mathbf{b} at P' can be expressed in terms of Q_{ij} ; for, clearly,

$$(2) \quad \overline{u_a u_b'} = a_i b_j \overline{u_i u_j'} = Q_{ij} a_i b_j,$$

where, here and elsewhere, summation over repeated indices is to be understood. Now when we say that the turbulence is homogeneous and isotropic, we mean, in particular, that $Q_{ij} a_i b_j$ is invariant to all translations and proper rotations of the vector configuration ξ , \mathbf{a} , and \mathbf{b} as a rigid body and also to reflections at the origin.

Similarly, the correlation $\overline{u_a u_b u_c'}$ of the velocities u_a , u_b , and u_c' along directions specified by the unit vectors \mathbf{a} and \mathbf{b} at P and \mathbf{c} at P' can be expressed in

terms of the triple correlation tensor

$$(3) \quad T_{ijk} = \overline{u_i u_j u'_k};$$

thus,

$$(4) \quad \overline{u_a u_b u'_c} = T_{ijk} a_i b_j c_k.$$

In isotropic turbulence $T_{ijk} a_i b_j c_k$ should again be a scalar invariant to all rotations of the vector configuration ξ , \mathbf{a} , \mathbf{b} , and \mathbf{c} as a rigid body and to reflections at the origin. Robertson pointed out that, in virtue of this invariance of the scalar products like $Q_{ij} a_i b_j$ and $T_{ijk} a_i b_j c_k$, we can write down quite readily the forms of the various tensors by appealing to the following result from the theory of invariants: Any invariant function of any number of vectors ξ , \mathbf{a} , \mathbf{b} , \dots , etc., can be expressed in terms of the fundamental invariants of the following two types: (1) the scalar products such as $(\xi \cdot \mathbf{a}) = \xi_i a_i$ and $(\mathbf{a} \cdot \mathbf{b}) = a_i b_i$ of any two vectors including the scalar squares $(\xi \cdot \xi)$, $(\mathbf{a} \cdot \mathbf{a})$, etc., and (2) the determinants such as $[\mathbf{ab}\xi] = \epsilon_{ijk} a_i b_j \xi_k$ of any three of the vectors, where ϵ_{ijk} is the usual alternating symbol.

Among the scalar invariants constructed in accordance with the foregoing theorem we must distinguish between two classes: the class which can be expressed as sums and products of the scalar products only (*i.e.*, the scalar invariants of type 1 only); and the class which can be expressed as sums and products of an odd number of determinants (*i.e.*, the scalar invariants of type 2) and the scalar products. The invariants of the first class are unchanged under the full rotation group, *i.e.*, not only for the proper rotations exemplified by the motions of a rigid body but also for the "improper" rotations such as reflections in a point. We shall call the invariants of the second class *skew invariants* and the corresponding tensors *skew tensors*. In the theory of isotropic turbulence we shall have to deal with both types of invariants and tensors. Thus the correlations Q_{ij} and T_{ijk} are true isotropic tensors, and the scalar products $Q_{ij} a_i b_j$ and $T_{ijk} a_i b_j c_k$ should be expressible in terms of the scalar invariants of type 1 only. On the other hand, correlations such as $\overline{u_i \omega'_j}$ and $\overline{u_i u_j \omega'_k}$ which include an odd number of the components of the vorticity $\boldsymbol{\omega}$, are skew isotropic tensors which transform as tensors under proper rotations but which take the opposite sign to true tensors on reflection in the origin. The corresponding skew forms should be expressible as sums and products of an odd number of the available determinants and, of course, the scalar products as well.

As we have already remarked, by appealing to the foregoing results from the theory of invariants, we can write down the forms of the various correlation tensors. Thus, considering $Q_{ij} a_i b_j$, we observe that it must be expressible in terms of $(\xi \cdot \mathbf{a})$, $(\xi \cdot \mathbf{b})$, and $(\mathbf{a} \cdot \mathbf{b})$ only. And since $Q_{ij} a_i b_j$ is bilinear, it can only be of the form

$$(5) \quad Q_{ij} a_i b_j = Q_1 (\xi \cdot \mathbf{a})(\xi \cdot \mathbf{b}) + Q_2 (\mathbf{a} \cdot \mathbf{b}),$$

where Q_1 and Q_2 are two arbitrary functions of the distance $r = (\boldsymbol{\xi} \cdot \boldsymbol{\xi})^{\frac{1}{2}}$ between the two points considered. Since (5) must be true for all \mathbf{a} and \mathbf{b} , it follows that the general form of an isotropic tensor of the second order is

$$(6) \quad Q_{ij} = Q_1 \xi_i \xi_j + Q_2 \delta_{ij}.$$

Similarly, by considering the scalar products available for the construction of the scalar invariant $T_{ijk} a_i b_j c_k$ [namely, $(\boldsymbol{\xi} \cdot \mathbf{a})$, $(\boldsymbol{\xi} \cdot \mathbf{b})$, $(\boldsymbol{\xi} \cdot \mathbf{c})$, $(\mathbf{a} \cdot \mathbf{b})$, $(\mathbf{b} \cdot \mathbf{c})$, and $(\mathbf{c} \cdot \mathbf{a})$], we readily verify that the most general form of an isotropic tensor of the third order is

$$(7) \quad T_{ijk} = T_1 \xi_i \xi_j \xi_k + T_2 \xi_i \delta_{jk} + T_3 \xi_j \delta_{ki} + T_4 \xi_k \delta_{ij},$$

where T_1 , T_2 , T_3 , and T_4 are four arbitrary functions of r . In the particular case of the triple correlation $\overline{u_i u_j u'_k}$, it is clear that it must be symmetrical in the indices i and j , and this requires that $T_2 = T_3$ in (7).

In the statistical theory of turbulence the correlation tensors one considers are generally solenoidal in one or more of their indices. This solenoidal property results from an application of the equation of continuity. For, in an incompressible fluid (to which most attention has been given so far; see, however, Sec. 4 of this paper) the equation of continuity,

$$(8) \quad \begin{aligned} \partial u_i \\ \partial x_i \end{aligned} = 0,$$

requires that the velocity field at any point be divergence-free. Consequently, the tensor $\overline{u_i u'_j}$ must be solenoidal in both its indices, whereas the triple correlation tensor $\overline{u_i u_j u'_k}$ must be solenoidal in the last index k . We can impose these solenoidal conditions on the tensors given by equations (6) and (7) and obtain certain differential equations (one in the case of Q_{ij} and two in the case of T_{ijk}) connecting the coefficients of these tensors. These differential equations will reduce the number of independent scalars required for the definition of Q_{ij} and T_{ijk} . This is the procedure which Robertson [3] has followed in his paper. However, it appears that the representation of a tensor that is solenoidal in one or more of its indices in terms of a minimal number of scalars can be achieved most simply by expressing the tensors as the curl with respect to those indices of a *skew tensor*. Thus, expressing

$$(9) \quad Q_{ij} = \epsilon_{ilm} \frac{\partial q_{im}}{\partial \xi_l},$$

where q_{ij} is a skew isotropic tensor of the second order, we can satisfy the solenoidal and the isotropic conditions simultaneously. [Since Q_{ij} will be symmetrical in its indices, it will also be solenoidal in i .] Since out of three vectors $\boldsymbol{\xi}$, \mathbf{a} , and \mathbf{b} we can form one and only one determinant, it is clear that the most general form of q_{ij} is

$$(10) \quad q_{ij} = Q \epsilon_{ijk} \xi_k$$

where Q is an arbitrary function of r . Taking the curl of q_{ij} with respect to the index j , we find that

$$(11) \quad Q_{ij} = \frac{Q'}{r} \xi_i \xi_j - (rQ' + 2Q)\delta_{ij},$$

where a prime attached to a scalar function (such as Q) denotes differentiation with respect to r . This then is the most general form of a solenoidal isotropic tensor of the second order. We may say that Q is the *defining scalar* of the tensor Q_{ij} . This representation of Q_{ij} in terms of a defining scalar is unique; for, $Q = 0$ implies that $Q_{ij} \equiv 0$, and conversely from $Q_{ij} \equiv 0$ we can conclude that $Q = 0$ (*i.e.*, provided we do not allow any singularity for Q at $r = 0$).

If Q_{ij} is isotropic and solenoidal, then so is $\nabla^2 Q_{ij}$ since the Laplacian is a scalar operator. The defining scalar of $\nabla^2 Q_{ij}$ can be obtained by applying the Laplacian directly to (9) since the operation of the Laplacian and the curl are permutable. In this manner we find that

$$(12) \quad \nabla^2 q_{ij} = \left(\frac{\partial^2 Q}{\partial r^2} + \frac{4}{r} \frac{\partial Q}{\partial r} \right) \epsilon_{ijl} \xi_l.$$

Accordingly, the defining scalar of $\nabla^2 Q_{ij}$ is

$$(13) \quad \frac{\partial^2 Q}{\partial r^2} + \frac{4}{r} \frac{\partial Q}{\partial r}.$$

As an application of the foregoing results we may note that, if Q_{ij} is isotropic and solenoidal, then the tensor equation

$$(14) \quad \frac{\partial Q_{ij}}{\partial t} = \nabla^2 Q_{ij}$$

is equivalent to the scalar equation

$$(15) \quad \frac{\partial Q}{\partial t} = \frac{\partial^2 Q}{\partial r^2} + \frac{4}{r} \frac{\partial Q}{\partial r}$$

for the defining scalar.

By an accidental circumstance peculiar to the case, the foregoing discussion of the second-order isotropic solenoidal tensor Q_{ij} does not bring out one important consideration which must be taken into account in representing solenoidal tensors as the curl of suitably defined skew tensors: that is the question of gauge invariance. The importance of this consideration will become clear when we try to express the triple correlation $T_{ijk} = \overline{u_i u_j u_k}$ in the form

$$(16) \quad T_{ijk} = \epsilon_{klm} \frac{\partial t_{ijm}}{\partial \xi_l},$$

where t_{ijk} is a third-order isotropic skew tensor. Now, to construct a skew trilinear form, $t_{ijk} a_i b_j c_k$, we have the four determinants $[\mathbf{abc}]$, $[\mathbf{ab}\xi]$, $[\mathbf{bc}\xi]$, and $[\mathbf{ca}\xi]$ available. From this it would appear that a general skew trilinear form

must be a linear combination of

$$(17) \quad [\mathbf{abc}], \quad (\mathbf{c} \cdot \boldsymbol{\xi})[\mathbf{ab}\boldsymbol{\xi}], \quad (\mathbf{a} \cdot \boldsymbol{\xi})[\mathbf{bc}\boldsymbol{\xi}], \quad \text{and} \quad (\mathbf{b} \cdot \boldsymbol{\xi})[\mathbf{ca}\boldsymbol{\xi}]$$

with coefficients which are arbitrary functions of r . Correspondingly, it would appear that the general skew tensor of the third order must be a linear combination of the *four* tensors

$$(18) \quad \epsilon_{ijk}, \quad \xi_k \epsilon_{ijl} \xi_l, \quad \xi_i \epsilon_{jkl} \xi_l, \quad \text{and} \quad \xi_j \epsilon_{kil} \xi_l.$$

However, in virtue of the identity

$$(19) \quad \xi_i \epsilon_{jkl} \xi_l + \xi_j \epsilon_{kil} \xi_l + \xi_k \epsilon_{ijl} \xi_l = r^2 \epsilon_{ijk},$$

only *three* of the four tensors (18) are linearly independent. Also, since

$$(20) \quad \frac{\partial}{\partial \xi_k} Q \epsilon_{ijl} \xi_l = \frac{Q'}{r} \xi_k \epsilon_{ijl} \xi_l + Q \epsilon_{ijk},$$

where Q is an arbitrary function of r , it follows that, for the purposes of defining a solenoidal tensor according to (16), the tensor $Q \epsilon_{ijk}$ is equivalent to the tensor $-(Q'/r) \xi_k \epsilon_{ijl} \xi_l$, since the two tensors differ only by a gradient of a vector and the curl of this difference taken in the fashion (16) is zero. Accordingly, for defining (in a gauge-invariant fashion) a tensor T_{ijk} solenoidal in k , the most general skew tensor we need consider is

$$(21) \quad t_{ijk} = T_1 \xi_i \epsilon_{jkl} \xi_l + T_2 \xi_j \epsilon_{ikl} \xi_l,$$

where T_1 and T_2 are two arbitrary functions of r . If the tensor T_{ijk} is in addition symmetrical in the indices i and j (as is the case with $\overline{u_i u_j u_k}$), then

$$(22) \quad T_1 = T_2 = T \text{ (say)}$$

and

$$(23) \quad \begin{aligned} T_{ijk} &= \text{curl } T(\xi_i \epsilon_{jkl} \xi_l + \xi_j \epsilon_{ikl} \xi_l) \\ &= \frac{2}{r} T' \xi_i \xi_j \xi_k - (rT' + 3T)(\xi_i \delta_{jk} + \xi_j \delta_{ik}) + 2T \xi_k \delta_{ij}. \end{aligned}$$

Again it should be noted that the foregoing representation of the tensor T_{ijk} in terms of a single defining scalar T is unique in that $T = 0$ implies that $T_{ijk} \equiv 0$, and conversely from $T_{ijk} \equiv 0$ we can conclude that $T = 0$ (*i.e.*, provided T has no singularity at $r = 0$).

By operating the Laplacian on t_{ijk} given by equation (21), we find that the defining scalar of $\nabla^2 T_{ijk}$ is

$$(24) \quad \frac{\partial^2 T}{\partial r^2} + \frac{6}{r} \frac{\partial T}{\partial r}.$$

Thus the equation

$$(25) \quad \frac{\partial T_{ijk}}{\partial t} = \nabla^2 T_{ijk},$$

where T_{ijk} is an isotropic tensor symmetrical in i and j and solenoidal in k , is equivalent to the equation

$$(26) \quad \frac{\partial T}{\partial t} = \frac{\partial^2 T}{\partial r^2} + \frac{6}{r} \frac{\partial T}{\partial r}$$

for the defining scalar T .

The contracted tensor

$$(27) \quad T_{ij} = \frac{\partial T_{ikj}}{\partial \xi_k}$$

of the triple correlation $\overline{u_i u_j u'_k}$ occurs in the treatment of the Stokes-Navier equation [cf. equation (37) below]. The tensor T_{ij} is clearly solenoidal, and its defining scalar can be found by similarly contracting the skew tensor t_{ijk} ; thus

$$(28) \quad \frac{\partial}{\partial \xi_k} T(\xi_i \epsilon_{kjl} \xi_l + \xi_k \epsilon_{ijl} \xi_l).$$

We find this is equal to

$$(29) \quad \left(r \frac{\partial T}{\partial r} + 5T \right) \epsilon_{ijl} \xi_l.$$

Hence the defining scalar of T_{ij} is

$$(30) \quad \left(r \frac{\partial}{\partial r} + 5 \right) T.$$

The foregoing theory of isotropic tensors adapts itself quite readily to the treatment of the Stokes-Navier equation:

$$(31) \quad \frac{\partial u_i}{\partial t} + \frac{\partial}{\partial x_k} u_i u_k = - \frac{1}{\rho} \frac{\partial p}{\partial x_i} + \nu \nabla^2 u_i.$$

In this equation ν is the kinematic viscosity. Multiplying equation (31) by the velocity component u'_j at x'_i and averaging the resulting equation, we have

$$(32) \quad \overline{u'_j \frac{\partial u_i}{\partial t}} + \frac{\partial}{\partial x_k} \overline{u_i u_k u'_j} = \nu \nabla^2 \overline{u_i u'_j}.$$

[The term in the pressure in the equation of motion does not appear in this equation, since the correlation $\overline{p u'_j}$, being a solenoidal isotropic vector, is identically zero; for, if such a vector existed, it should be expressible as the curl of a skew isotropic vector; such a vector clearly does not exist, since with two vectors ξ and \mathbf{a} we cannot form a determinant to represent the corresponding skew linear form.]

Interchanging the indices i and j and also the primed and the unprimed quantities in equation (32), we have

$$(33) \quad \overline{u_i \frac{\partial u'_j}{\partial t}} + \frac{\partial}{\partial x'_k} \overline{u'_j u'_k u_i} = \nu \nabla^2 \overline{u_i u'_j}.$$

Adding equations (32) and (33) and remembering that

$$(34) \quad \frac{\partial}{\partial \xi_i} = \frac{\partial}{\partial x'_i} = - \frac{\partial}{\partial x_i},$$

we have

$$(35) \quad \frac{\partial}{\partial t} \overline{u_i u'_j} = 2 \frac{\partial}{\partial \xi_k} \overline{u_i u_k u'_j} + 2\nu \nabla^2 \overline{u_i u'_j}.$$

In deriving this last equation we have made further use of the relation

$$(36) \quad \overline{u_i u_j u'_k} = -\overline{u'_i u'_j u_k},$$

which is a consequence of the assumed homogeneity.

In terms of the tensors Q_{ij} and T_{ijk} equation (35) can be rewritten in the form

$$(37) \quad \frac{\partial Q_{ij}}{\partial t} = 2 \frac{\partial}{\partial \xi_k} T_{ikj} + 2\nu \nabla^2 Q_{ij}.$$

The scalars defining the various second-order tensors occurring in this equation are [cf. equations (15) and (30)]

$$(38) \quad \frac{\partial Q}{\partial t}, \quad \left(r \frac{\partial}{\partial r} + 5 \right) T, \quad \text{and} \quad \left(\frac{\partial^2}{\partial r^2} + \frac{4}{r} \frac{\partial}{\partial r} \right) Q,$$

respectively. Hence equation (37) is equivalent to the scalar equation

$$(39) \quad \frac{\partial Q}{\partial t} = 2 \left(r \frac{\partial}{\partial r} + 5 \right) T + 2\nu \left(\frac{\partial^2}{\partial r^2} + \frac{4}{r} \frac{\partial}{\partial r} \right) Q.$$

This is the equation of von Kármán and Howarth derived in a different way.

Equation (39) admits an integral: multiplying it by r^4 and integrating from 0 to r , we have

$$(40) \quad \frac{\partial}{\partial t} \int_0^r Q r^4 dr = 2r^5 T + 2\nu r^4 \frac{\partial Q}{\partial r}.$$

If we now assume that $r^5 T \rightarrow 0$ and $r^4 Q' \rightarrow 0$ as $r \rightarrow \infty$, then it follows that

$$(41) \quad \int_0^\infty Q(r,t) r^4 dr = \text{const.}$$

This is the so-called Loitsiansky invariant. As Batchelor [4] has shown, the meaning of this invariant is that "the spectral density at very low wave numbers is permanent and is determined by the initial conditions." We shall see that a similar invariant exists also in the theory of turbulence of a compressible fluid.

2. The theory of axisymmetric tensors and the equations of axisymmetric turbulence. While the theory of isotropic turbulence which we have described in part in the preceding section introduces the subject in its simplest context, it is, nevertheless, almost invariably true that, whenever turbulence is present, there is also present a preferred direction defined by the direction of the mean

flow. Indeed, since the fluctuations in the velocity field are generally defined with respect to the local mean values, it would seem that a more natural starting point for the theory will be provided by the concept of *axisymmetry*, which will require the mean value of any function of the velocities to be invariant not for the full rotation group but only for rotations about the preferred direction λ (say) and for reflections in planes containing λ and perpendicular to λ . A corresponding theory of axisymmetric turbulence is best developed in terms of a theory of *axisymmetric tensors* analogous to the theory of isotropic tensors.

Let $F_{ijk\dots}$ denote a Cartesian tensor; further let \mathbf{a} , \mathbf{b} , \mathbf{c} , etc., denote arbitrary unit vectors. Consider the scalar product

$$(42) \quad F(\mathbf{a}, \mathbf{b}, \mathbf{c}, \dots) = F_{ijk\dots} a_i b_j c_k \dots$$

We shall say that the tensor $F_{ijk\dots}$ is axially symmetric about a direction specified by a unit vector λ if $F(\mathbf{a}, \mathbf{b}, \mathbf{c}, \dots)$ is invariant for arbitrary rotations about the direction λ and for reflections in planes containing λ and normal to λ .

It is of interest to see the relation between axisymmetric tensors and forms and isotropic tensors and forms. In the theory of isotropic tensors, the form F defined as in equation (42) is invariant for rotations and reflections of the configurations formed by the vectors \mathbf{a} , \mathbf{b} , \mathbf{c} , etc., and ξ , where $\xi_i = x'_i - x_i$ and x'_i and x_i are the coordinates of the two points at which correlations of the field variables are considered. On the other hand in the theory of axisymmetric tensors the form F must be invariant for all rotations and reflections of the vector configuration formed by ξ , \mathbf{a} , \mathbf{b} , \mathbf{c} , etc., and λ . The general problem in the theory of axisymmetric tensors is, therefore, to determine the form $F(\xi, \lambda; \mathbf{a}, \mathbf{b}, \mathbf{c}, \dots)$ which will be invariant under the full rotation group of the vector configuration ξ , λ , \mathbf{a} , \mathbf{b} , \mathbf{c} , etc. The formal problem can be readily solved by appealing to the same theorem in the theory of invariants quoted in the last section.

As in the theory of isotropic tensors we must distinguish between axisymmetric tensors and skew axisymmetric tensors, which take the opposite sign to true tensors on reflection in the origin. Again, it is not difficult to write down the general expressions for such skew tensors, since the corresponding skew forms must be expressible as sums of products of an odd number of determinants such as $[\mathbf{ab}\xi]$, $[\mathbf{ab}\lambda]$, $[\mathbf{a}\lambda\xi]$, $[\mathbf{abc}]$, etc., formed by any three of the vectors ξ , λ , \mathbf{a} , \mathbf{b} , \mathbf{c} , etc. By choosing combinations of the scalar products and an odd number of the available determinants which will be in conformity with (42), we can write down the corresponding skew forms and tensors.

In the theory of axisymmetric turbulence (as in the case of isotropic turbulence) particular interest attaches to tensors which are solenoidal in one or more of their indices. In these cases the tensors can be expressed as the curl of certain suitably defined skew tensors, and defining scalars can be introduced, as in the theory of isotropic solenoidal tensors. However, in representing the solenoidal tensors in terms of certain defining scalars, particular attention must

be given to selecting a minimal set of linearly independent skew tensors and also to the matter of gauge invariance. The theory of axisymmetric tensors of the first, second, and third orders along these lines has been completed by Chandrasekhar [5] (see also Batchelor [6]). The following results on axisymmetric tensors of the first and second orders are taken from [5].

(i) *Axisymmetric vector.* An axisymmetric vector L_i must be of the form

$$(43) \quad L_i = M\xi_i + N\lambda_i,$$

where M and N are arbitrary functions of r and $r\mu$, where

$$(44) \quad r^2 = (\xi \cdot \xi) \quad \text{and} \quad r\mu = (\xi \cdot \lambda).$$

If L_i is solenoidal, it can be expressed as

$$(45) \quad \begin{aligned} L_i &= \text{curl } L(r, \mu) \epsilon_{ilm} \lambda_l \xi_m \\ &= - \left(\mu \frac{\partial L}{\partial r} + \frac{1 - \mu^2}{r} \frac{\partial L}{\partial \mu} \right) \xi_i + \left(r \frac{\partial L}{\partial r} + 2L \right) \lambda_i. \end{aligned}$$

The representation of an axisymmetric solenoidal vector L_i in terms of a single defining scalar L in the manner (45) is unique.

The defining scalar of $\nabla^2 L_i$ is

$$(46) \quad \Delta L = \left(\frac{\partial^2}{\partial r^2} + \frac{4}{r} \frac{\partial}{\partial r} + \frac{1 - \mu^2}{r^2} \frac{\partial^2}{\partial \mu^2} - \frac{4\mu}{r^2} \frac{\partial}{\partial \mu} \right) L.$$

(ii) *Axisymmetric tensors of the second order.* An axisymmetric tensor Q_{ij} must be of the form

$$(47) \quad Q_{ij} = A\xi_i\xi_j + B\delta_{ij} + C\lambda_i\lambda_j + D\lambda_i\xi_j + E\xi_i\lambda_j,$$

where A , B , C , D , and E are arbitrary functions of r and $r\mu$. [Note that, in contrast to an isotropic tensor, Q_{ij} is now not necessarily symmetrical in i and j .] If Q_{ij} is solenoidal in j , it can be expressed in terms of three defining scalars Q_1 , Q_2 , and Q_3 in the manner

$$(48) \quad Q_{ij} = \epsilon_{ilm} \frac{\partial q_{im}}{\partial \xi_l},$$

where

$$(49) \quad q_{ij} = Q_1 \epsilon_{ijl} \xi_l + Q_2 \lambda_j \epsilon_{ilm} \lambda_l \xi_m + Q_3 \xi_j \epsilon_{ilm} \lambda_l \xi_m.$$

Thus

$$(50) \quad \begin{aligned} Q_{ij} &= \{ \xi_i \xi_j D_r - \delta_{ij} (r^2 D_r + r\mu D_\mu + 2) + \lambda_i \xi_j D_\mu \} Q_1 \\ &\quad + \{ \xi_i \xi_j D_r - \delta_{ij} [r^2 (1 - \mu^2) D_r + 1] + \lambda_i \lambda_j (r^2 D_r + 1) \\ &\quad - (\lambda_i \xi_j + \xi_i \lambda_j) r\mu D_r \} Q_2 + \{ -\xi_i \xi_j D_\mu + \delta_{ij} [r^2 (1 - \mu^2) D_\mu - r\mu] \\ &\quad - \lambda_i \lambda_j r^2 D_\mu + (\lambda_i \xi_j + \xi_i \lambda_j) r\mu D_\mu + \xi_i \lambda_j \} Q_3, \end{aligned}$$

where for the sake of brevity we have written

$$(51) \quad D_r = \frac{1}{r} \frac{\partial}{\partial r} - \frac{\mu}{r^2} \frac{\partial}{\partial \mu} \quad \text{and} \quad D_\mu = \frac{1}{r} \frac{\partial}{\partial \mu}.$$

The foregoing representation of Q_{ij} in terms of Q_1 , Q_2 , and Q_3 is unique.

If Q_{ij} is in addition symmetrical in i and j , then

$$(52) \quad Q_3 = D_\mu Q_1 = \frac{1}{r} \frac{\partial Q_1}{\partial \mu},$$

and we have only two defining scalars.

The defining scalars of the Laplacian of Q_{ij} , which is solenoidal in j , are

$$(53) \quad \Delta Q_1, \quad \Delta Q_2 + 2D_{\mu\mu}Q_1, \quad \text{and} \quad \Delta Q_3 + 2D_{r\mu}Q_1,$$

where $D_{\mu\mu} = D_\mu D_\mu$ and $D_{r\mu} = D_r D_\mu = D_\mu D_r$.

In the theory of axisymmetric turbulence, one obtains from the Stokes-Navier equation a pair of equations governing the two scalars Q_1 and Q_2 defining the fundamental correlation tensor Q_{ij} . They are (cf. Chandrasekhar [5], Secs. 8 and 9):

$$(54) \quad \begin{aligned} \frac{\partial Q_1}{\partial t} &= 2\nu \Delta Q_1 + S_1, \\ \frac{\partial Q_2}{\partial t} &= 2\nu(\Delta Q_2 + 2D_{\mu\mu}Q_1) + S_2, \end{aligned}$$

where S_1 and S_2 are the scalars defining

$$(55) \quad S_{ij} = \frac{\partial}{\partial \xi_k} (\overline{u_i u_k u_j} - \overline{u_i u'_k u'_j}) + \frac{1}{\rho} \left(\frac{\partial}{\partial \xi_i} \overline{p u_j} - \frac{\partial}{\partial \xi_j} \overline{p u_i} \right).$$

Equations (54) replace the equation of von Kármán and Howarth in the theory of isotropic turbulence.

Equations (54) have been used to discuss the decay of turbulence during the last stages of the decay when the inertial term in the Stokes-Navier equation can be neglected [7].

3. Turbulence in magneto-hydrodynamics. A problem which has, in recent years, gained considerable importance in various geophysical and astrophysical contexts is the question of the growth of stray magnetic fields in a highly conducting turbulent fluid.

If we consider an incompressible fluid with a high electrical conductivity σ , then with suitable approximations the equations governing the velocity and the magnetic fields can be written in the forms [8-10]

$$(56) \quad \frac{\partial u_i}{\partial t} + \frac{\partial}{\partial x_k} (u_i u_k - h_i h_k) = -\frac{1}{\rho} \frac{\partial}{\partial x_i} \left(p + \frac{1}{2} \rho |\mathbf{h}|^2 \right) + \nu \nabla^2 u_i$$

and

$$(57) \quad \frac{\partial h_i}{\partial t} + \frac{\partial}{\partial x_k} (h_i u_k - u_i h_k) = \lambda \nabla^2 h_i,$$

where $\lambda = 1/(4\pi\mu\sigma)$ (μ being the magnetic permeability) and \mathbf{h} is related to the magnetic field \mathbf{H} by

$$(58) \quad \mathbf{h} = \left(\frac{\mu}{4\pi\rho} \right)^{\frac{1}{2}} \mathbf{H}.$$

Defined in this manner, \mathbf{h} has the dimensions of a velocity.

Both \mathbf{u} and \mathbf{h} are solenoidal vectors; however, \mathbf{h} , unlike \mathbf{u} but like the vorticity $\boldsymbol{\omega}$, is an axial vector.

It will be seen that equation (57) is formally the same as that governing the vorticity in an incompressible fluid with λ playing the role of ν . Therefore if $\lambda = 0$ (*i.e.*, in the case of infinite conductivity), the circulation theorems of Kelvin and Helmholtz on the vorticity in an inviscid fluid can be translated in terms of \mathbf{H} : *e.g.*, the statement that "the vortex lines move with the fluid" has now the counterpart that "the magnetic lines move with the fluid."

It is evident that by defining various double and triple correlations we can treat equations (56) and (57) in a manner analogous to the Stokes-Navier equation in Secs. 1 and 2. (For the sake of simplicity we shall restrict ourselves to the case of homogeneous isotropic turbulence; the extension to the case of axisymmetric turbulence is straightforward and can be carried out if necessary.) Thus, from equation (56) we can derive [cf. equations (31) to (37)]

$$(59) \quad \frac{\partial Q_{ij}}{\partial t} = 2 \frac{\partial}{\partial \xi_k} (T_{ikj} - S_{ikj}) + 2\nu \nabla^2 Q_{ij},$$

where Q_{ij} and T_{ijk} denote the double ($\overline{u_i u_j}$) and the triple ($\overline{u_i u_j u_k}$) correlations, respectively, and

$$(60) \quad S_{ijk} = \overline{h_i h_j u_k}.$$

Since S_{ijk} is symmetrical in i and j and solenoidal in k , it can be defined, like T_{ijk} , in terms of a single scalar; thus,

$$(61) \quad S_{ijk} = \text{curl } S(\xi_i \epsilon_{jkl} \xi_l + \xi_j \epsilon_{ikl} \xi_l).$$

In terms of the defining scalars, equation (59) becomes [cf. equation (39)]

$$(62) \quad \frac{\partial Q}{\partial t} = 2 \left(r \frac{\partial}{\partial r} + 5 \right) (T - S) + 2\nu \left(\frac{\partial^2}{\partial r^2} + \frac{4}{r} \frac{\partial}{\partial r} \right) Q.$$

This is the generalization of the von Kármán-Howarth equation (39) to magneto-hydrodynamics. And like the von Kármán-Howarth equation, equation (62) also admits the invariant

$$(63) \quad \int_0^\infty Q(r, t) r^4 dr = \text{const.}$$

From the continued existence of this invariant in magneto-hydrodynamics, we can conclude that no transfer of energy from the velocity field to the magnetic field takes place among the largest eddies present.

Considering equation (57), we can derive two further equations governing the defining scalars, H and R , of the correlations $\overline{h_i h_j}$ and $\overline{u_i h_j}$. The former correlation should clearly be of the form

$$(64) \quad \overline{h_i h_j} = \text{curl } H \epsilon_{ijl} \xi_l = \frac{H'}{r} \xi_i \xi_j - (rH' + 2H) \delta_{ij}.$$

On the other hand, $\overline{u_i h_j'}$ must be a skew tensor since, if \mathbf{h} is assumed to be an axial vector, accordingly, on this assumption,¹ it must be of the form

$$(65) \quad \overline{u_i h_j'} = R \epsilon_{ijl} \xi_l.$$

The equations governing H and R are found to be [9]

$$(66) \quad \frac{\partial H}{\partial t} = 2P + 2\lambda \left(\frac{\partial^2}{\partial r^2} + \frac{4}{r} \frac{\partial}{\partial r} \right) H$$

and

$$(67) \quad \frac{\partial R}{\partial t} = \left(r \frac{\partial}{\partial r} + 5 \right) (U - V) + \left(\frac{\partial^2}{\partial r^2} + \frac{4}{r} \frac{\partial}{\partial r} \right) [(\lambda + \nu)R - W],$$

where P , U , V , and W are the defining scalars of the following correlations:

$$(68) \quad \begin{aligned} \overline{u_i u_j h_k'} &= U (\xi_i \epsilon_{jkl} \xi_l + \xi_j \epsilon_{ikl} \xi_l), \\ \overline{h_i h_j h_k'} &= V (\xi_i \epsilon_{jkl} \xi_l + \xi_j \epsilon_{ikl} \xi_l), \\ \overline{(h_i u_j - h_j u_i) h_k'} &= P (\xi_i \delta_{jk} - \xi_j \delta_{ik}), \\ \overline{u_i (h_j' u_k' - h_k' u_j')} &= (2W + rW') \epsilon_{ijk} - \frac{W'}{r} \xi_i \epsilon_{jkl} \xi_l. \end{aligned}$$

It will be seen that the equation for R allows an invariant of the Loitsiansky type. Also, from the fact that Q admits a Loitsiansky invariant, it can be concluded that H must also admit a Loitsiansky invariant, which must in fact be zero [10].

By considering the behavior of equations (62) and (66) for $r \rightarrow 0$, we can derive the equations governing the rate of dissipation of energy. Thus, we find [8, 9]

$$(69) \quad \begin{aligned} \frac{1}{2} \frac{d}{dt} \overline{|\mathbf{u}|^2} &= -7.5 \overline{h_1^2} \frac{\partial u_1}{\partial x_1} - 60\nu Q_2, \\ \frac{1}{2} \frac{d}{dt} \overline{|\mathbf{h}|^2} &= +7.5 \overline{h_1^2} \frac{\partial u_1}{\partial x_1} - 60\lambda H_2, \end{aligned}$$

where Q_2 and H_2 define the curvatures of the longitudinal correlations $\overline{u_1 u_1'}$ and $\overline{h_1 h_1'}$ at $r = 0$. According to equations (69) the dissipation of the kinetic energy consists of two terms: the dissipation into heat by viscosity and the transformation of the kinetic energy into magnetic energy by the stretching of the magnetic lines of force; and this gain in the magnetic energy appears in the equation for $\overline{|\mathbf{h}|^2}$. The term in λ in the latter equation corresponds to the loss of magnetic energy by Joule heating.

¹ This assumption is not essential; for if on the contrary \mathbf{h} is assumed to be a polar vector, then $\overline{u_i h_j'}$ must be of the form $\text{curl } R \epsilon_{ijl} \xi_l$, and similarly the correlations on the left-hand sides of (68) will be expressible as curls of the quantities on the right-hand side. With these redefinitions equation (67) governing R will continue to be valid. This is as it should be, since none of the physical results derived can depend on whether \mathbf{h} is axial or polar.

By adding the equations (69) we have

$$(70) \quad \frac{1}{2} \frac{d}{dt} (\overline{|\mathbf{u}|^2} + \overline{|\mathbf{h}|^2}) = -60(\nu Q_2 + \lambda H_2).$$

The physical meaning of this equation is that the rate of loss of energy from the system is entirely due to dissipation either by viscosity in the form of molecular motion or by conductivity in the form of Joule heat.

4. The fluctuations of density in homogeneous isotropic turbulence in a compressible fluid. With few exceptions current discussions relating to the statistical theory of turbulence have been restricted to incompressible fluids. The principal simplification which this assumption introduces is, of course, the solenoidal property of the velocity and therefore also of the various correlations considered in the theory. This essential simplification is lost when we go to compressible fluids, and this fact also explains why attempts to treat turbulence in terms of the same types of velocity correlations have not proved very successful. However, it appears that, by shifting our attention to correlations in the fluctuations of density, we can get some insight into the processes taking place in turbulence in a compressible fluid (see Chandrasekhar [11, 12]). For example, from the equation of continuity alone we can derive an invariant analogous to the Loitsiansky invariant in the theory of turbulence of an incompressible fluid.

Now the equation of continuity for a compressible fluid is

$$(71) \quad \frac{\partial \rho}{\partial t} + \frac{\partial}{\partial x_i} (\rho u_i) = 0.$$

From this equation we can readily derive by the usual methods that

$$(72) \quad \frac{\partial}{\partial t} \overline{\rho \rho'} + \frac{\partial}{\partial x_i} \overline{\rho' \rho u_i} + \frac{\partial}{\partial x_i} \overline{\rho \rho' u_i} = 0.$$

In homogeneous isotropic turbulence $\overline{\rho \rho'}$ is a scalar function depending, apart from time, only on the distance r between the points x_i and x'_i considered. However, instead of $\overline{\rho \rho'}$ it is convenient to define

$$(73) \quad \overline{\rho \rho'} - \bar{\rho}^2 = \bar{\omega}(r, t),$$

since defined in this manner $\bar{\omega} \rightarrow 0$ as $r \rightarrow \infty$. Also, since in homogeneous turbulence the mean density $\bar{\rho}$ is a constant independent of position and time, $\bar{\omega}$ differs from $\overline{\rho \rho'}$ only by an additive constant. An equivalent definition of $\bar{\omega}$ is

$$(74) \quad \bar{\omega} = \overline{(\rho - \bar{\rho})(\rho' - \bar{\rho})} = \overline{\delta \rho \delta \rho'},$$

where $\delta \rho$ is the instantaneous fluctuation in the density from the mean.

Again, in isotropic turbulence

$$(75) \quad \overline{\rho' \rho u_i} = - \overline{\rho \rho' u_i} = L(r, t) \xi_i,$$

where L is a function depending on r and t .

Combining equations (72), (73), and (75) and remembering (34), we obtain

$$(76) \quad \frac{\partial \bar{\omega}}{\partial t} = 2 \frac{\partial}{\partial \xi_i} L \xi_i = 2 \left(r \frac{\partial L}{\partial r} + 3L \right).$$

Equation (76) allows us to derive an invariant. Rewriting it in the form

$$(77) \quad r^2 \frac{\partial \bar{\omega}}{\partial t} = \frac{\partial}{\partial r} (r^3 L),$$

and integrating it from 0 to r , we have

$$(78) \quad \frac{\partial}{\partial t} \int_0^r r^2 \bar{\omega} dr = 2r^3 L.$$

If $L \rightarrow 0$ faster than r^{-3} does as $r \rightarrow \infty$, it follows from (78) that

$$(79) \quad \frac{\partial}{\partial t} \int_0^\infty r^2 \bar{\omega}(r, t) dr = 0,$$

or,

$$(80) \quad \int_0^\infty r^2 \bar{\omega}(r, t) dr = \text{const.}$$

As in the case of the Loitsiansky invariant, the meaning of this new invariant is that the large-scale components of the density fluctuations are permanent features of the system. More particularly, if a Fourier analysis of the density fluctuations is made and if $\Pi(k)$ denotes the spectrum of $|\bar{\delta\rho}|^2$, then for $k \rightarrow 0$, $\Pi(k)$ has the behavior $\Pi_0 k^2$, where Π_0 is a constant depending only on the initial conditions of the problem [11].

An equation of motion for $\bar{\omega}(r, t)$ can be derived from the equation

$$(81) \quad \frac{\partial^2 \rho}{\partial t^2} = \frac{\partial^2}{\partial x_i \partial x_j} (\rho u_i u_j) + \nabla^2 (p - \bar{p}) - \frac{4}{3} \mu \nabla^2 \frac{\partial u_j}{\partial x_j},$$

which follows from the Stokes-Navier equation for a compressible fluid. Thus, using equations (71) and (81) in the relation

$$(82) \quad \frac{\partial^2 \bar{\omega}}{\partial t^2} = \frac{\partial^2}{\partial t^2} \overline{\rho \rho'} = \overline{\rho' \frac{\partial^2 \rho}{\partial t^2}} + \overline{\rho \frac{\partial^2 \rho'}{\partial t^2}} + 2 \frac{\partial \rho}{\partial t} \frac{\partial \rho'}{\partial t},$$

we readily obtain

$$(83) \quad \frac{\partial^2 \bar{\omega}}{\partial t^2} = 2 \frac{\partial^2}{\partial \xi_i \partial \xi_j} [\overline{\rho \rho' (u_i u_j - u_i u_j')}] + 2 \nabla^2 [\overline{\rho' (p - \bar{p})}] - \frac{8}{3} \mu \nabla^2 \frac{\partial}{\partial \xi_j} \overline{\rho u_j'},$$

where now

$$(84) \quad \nabla^2 = \frac{1}{r^2} \frac{\partial}{\partial r} \left(r^2 \frac{\partial}{\partial r} \right).$$

Now we may suppose that the fourth-order correlations occurring in equation (83) can be expressed in terms of the second-order correlations, as in a joint

Gaussian distribution. A similar assumption has been made in evaluating the fluctuation of pressure in a turbulent incompressible fluid, with apparently satisfactory results [13]. On this assumption, we can replace the two fourth-order correlations in equation (83) by

$$(85) \quad \begin{aligned} \overline{\rho\rho'u_iu_j} &= \overline{\rho\rho'} \overline{u_iu_j} + \overline{\rho'u_i} \overline{\rho u_j} + \overline{\rho'u_j} \overline{\rho u_i} \\ &= \frac{1}{3}\overline{\rho\rho'} \overline{u^2}\delta_{ij}, \end{aligned}$$

where $\overline{u^2}$ denotes the mean-square velocity of turbulence and

$$(86) \quad \begin{aligned} \overline{\rho\rho'u_iu'_j} &= \overline{\rho\rho'} \overline{u_iu'_j} + \overline{\rho'u_i} \overline{\rho u'_j} + \overline{\rho u_i} \overline{\rho'u'_j} \\ &= \overline{\rho\rho'} \overline{u_iu'_j} - \overline{\rho u'_i} \overline{\rho u'_j}. \end{aligned}$$

With the foregoing substitutions equation (83) reduces to

$$(87) \quad \frac{\partial^2\bar{\omega}}{\partial t^2} = 2\nabla^2(\overline{p - \bar{p}})\rho' + \frac{2}{3}\overline{u^2}\nabla^2\bar{\omega} - 2\frac{\partial^2}{\partial\xi_i\partial\xi_j}(\overline{\rho\rho'} \overline{u_iu'_j} - \overline{\rho u'_i} \overline{\rho u'_j}) - \frac{8}{3}\mu\nabla^2\frac{\partial}{\partial\xi_j}\overline{\rho u'_j}.$$

We shall now further suppose that the variations in pressure and density which are continually taking place in the medium take place, at each point, adiabatically, *i.e.*,

$$(88) \quad \frac{\delta p}{\bar{p}} = \gamma \frac{\delta\rho}{\bar{\rho}},$$

where γ is the ratio of the specific heats. Consistent with this assumption, we should strictly ignore the term in viscosity in equation (87). Also we can replace

$$(89) \quad \overline{(p - \bar{p})\rho'} \quad \text{by} \quad \gamma \frac{\bar{p}}{\bar{\rho}} \overline{\delta\rho(\bar{\rho} + \delta\rho')} = c^2\bar{\omega}(r,t),$$

where c denotes the velocity of sound appropriate to the mean pressure and density. With these simplifications equation (83) reduces to

$$(90) \quad \frac{\partial^2\bar{\omega}}{\partial t^2} = 2\left(c^2 + \frac{1}{3}\overline{u^2}\right)\frac{1}{r^2}\frac{\partial}{\partial r}\left(r^2\frac{\partial\bar{\omega}}{\partial r}\right) - 2\frac{\partial^2}{\partial\xi_i\partial\xi_j}[\overline{\rho\rho'} \overline{u_iu'_j} - \overline{\rho u'_i} \overline{\rho u'_j}].$$

On the assumption that $\overline{u_iu'_j}$ and $\overline{\rho u'_i}$ tend to zero sufficiently rapidly as $r \rightarrow \infty$, it would follow from equation (90) that, under conditions of local isotropy [*i.e.*, under conditions when mean-square relative velocities such as $\overline{(u_i - u'_j)^2}$ are independent of time], it will allow periodic solutions whose behavior at infinity will be given by

$$(91) \quad \bar{\omega}(r,t) = \frac{\text{const.}}{r} \exp i\sigma \left[t + \frac{r}{(2c^2 + \frac{2}{3}\overline{u^2})^{\frac{1}{2}}} \right].$$

In other words the fluctuations in density are propagated over large distances in the medium with a velocity $(2c^2 + \frac{2}{3}\overline{u^2})^{\frac{1}{2}}$, and each scale of density fluctua-

tion varies periodically with its own characteristic period, independently of the others.

5. The gravitational instability of an infinite homogeneous turbulent medium. The manner of treating density fluctuations described in the preceding section has an application to the problem of the gravitational stability of an infinite homogeneous turbulent medium (cf. Chandrasekhar [12]; for the earlier treatment of the subject ignoring turbulence, see Jeans [14]). We shall briefly describe this application in this section.

We picture to ourselves an infinite homogeneous medium in which the gravitational effects of the fluctuations in density are important. Under these circumstances equation (81) of Sec. 4 is replaced by

$$(92) \quad \frac{\partial^2 \rho}{\partial t^2} = \frac{\partial^2}{\partial x_i \partial x_j} (\rho u_i u_j) + \nabla^2 (p - \bar{p}) - \frac{\partial}{\partial x_i} \left(\rho \frac{\partial V}{\partial x_i} \right) - \frac{4}{3} \mu \nabla^2 \frac{\partial u_j}{\partial x_j}$$

where V denotes the gravitational potential.

In the problem we are considering, we may write

$$(93) \quad p = \bar{p} + \delta p, \quad \rho = \bar{\rho} + \delta \rho, \quad \text{and} \quad V = \bar{V} + \delta V,$$

where \bar{p} , $\bar{\rho}$, and \bar{V} are certain constants. With these substitutions the term in the gravitational potential in equation (92) becomes

$$(94) \quad \frac{\partial}{\partial x_i} \left[(\bar{\rho} + \delta \rho) \frac{\partial}{\partial x_i} \delta V \right] \simeq \bar{\rho} \nabla^2 \delta V = -4\pi G \bar{\rho} \delta \rho,$$

where we have neglected quantities of the second order in $\delta \rho$ and further made use of the variation of Poisson's equation governing the gravitational potential. Using the result of equation (94) in equation (92), we have

$$(95) \quad \frac{\partial^2 \rho}{\partial t^2} = \frac{\partial^2}{\partial x_i \partial x_j} (\rho u_i u_j) + \nabla^2 \delta p + 4\pi G \bar{\rho} \delta \rho - \frac{4}{3} \mu \nabla^2 \frac{\partial u_j}{\partial x_j}$$

Introducing the correlation function $\bar{\omega}(r, t)$ [cf. equation (74)], using equation (95) instead of equation (81), making the same two simplifying assumptions expressed by equations (85), (86), and (89), and ignoring the term in viscosity, we obtain

$$(96) \quad \frac{\partial^2 \bar{\omega}}{\partial t^2} = 2 \left(c^2 + \frac{1}{3} \bar{u}^2 \right) \frac{1}{r^2} \frac{\partial}{\partial r} \left(r^2 \frac{\partial \bar{\omega}}{\partial r} \right) + 8\pi G \bar{\rho} \bar{\omega} \\ - 2 \frac{\partial^2}{\partial \xi_i \partial \xi_j} (\bar{\rho}' \bar{u}_i \bar{u}_j - \bar{\rho}' \bar{u}_j \bar{\rho}' \bar{u}_i).$$

For sufficiently large values of r the terms in the velocity correlations in equation (96) will become negligible, and the equation will tend to

$$(97) \quad \frac{\partial^2 \bar{\omega}}{\partial t^2} = 2 \left(c^2 + \frac{1}{3} \bar{u}^2 \right) \frac{1}{r^2} \frac{\partial}{\partial r} \left(r^2 \frac{\partial \bar{\omega}}{\partial r} \right) + 8\pi G \bar{\rho} \bar{\omega}.$$

But this equation admits spherical wave solutions of the form

$$(98) \quad \tilde{\omega}(r, t) = \frac{A(t)}{r} e^{ikr}.$$

Accordingly, we may expect that a superposition of these solutions will represent the asymptotic behavior of the solution of equation (96). On the other hand, the equation determining the amplitudes (at infinity) of these waves is

$$(99) \quad \frac{d^2 A}{dt^2} = -2 \left[\left(c^2 + \frac{1}{3} \bar{u}^2 \right) k^2 - 4\pi G \bar{\rho} \right] A.$$

Consequently if

$$(100) \quad k^2 < \frac{4\pi G \bar{\rho}}{c^2 + \frac{1}{3} \bar{u}^2},$$

the amplitudes of the corresponding spherical wave in the superposition will increase exponentially with time. In other words, eddies in the density fluctuations which are larger than a certain critical size will be amplified; in this we may see a tendency toward disintegration and formation of condensation in the medium.

BIBLIOGRAPHY

1. G. I. Taylor, *Statistical theory of turbulence*, I-IV, Proc. Roy. Soc. London Ser. A vol. 151 (1935) pp. 421-478.
2. T. von Kármán and L. Howarth, *On the statistical theory of isotropic turbulence*, Proc. Roy. Soc. London Ser. A vol. 164 (1938) pp. 192-215.
3. H. P. Robertson, *The invariant theory of isotropic turbulence*, Proc. Cambridge Philos. Soc. vol. 36 (1940) pp. 209-223.
4. G. K. Batchelor, *The role of big eddies in homogeneous turbulence*, Proc. Roy. Soc. London Ser. A vol. 195 (1949) pp. 513-532.
5. S. Chandrasekhar, *The theory of axisymmetric turbulence*, Philos. Trans. Roy. Soc. London Ser. A vol. 242 (1950) pp. 557-577.
6. G. K. Batchelor, *The theory of axisymmetric turbulence*, Proc. Roy. Soc. London Ser. A vol. 186 (1946) pp. 480-502.
7. S. Chandrasekhar, *The decay of axisymmetric turbulence*, Proc. Roy. Soc. London Ser. A vol. 203 (1950) pp. 358-364.
8. G. K. Batchelor, *On the spontaneous magnetic field in a conducting liquid in turbulent motion*, Proc. Roy. Soc. London Ser. A vol. 201 (1950) pp. 405-416.
9. S. Chandrasekhar, *The invariant theory of isotropic turbulence in magneto-hydrodynamics*, I, Proc. Roy. Soc. London Ser. A vol. 204 (1950) pp. 435-449.
10. ———, *The invariant theory of isotropic turbulence in magneto-hydrodynamics*, II, Proc. Roy. Soc. London Ser. A vol. 207 (1951) pp. 301-306.
11. ———, *The fluctuations of density in isotropic turbulence*, Proc. Roy. Soc. London Ser. A vol. 210 (1951) pp. 18-25.
12. ———, *The gravitational instability of an infinite homogeneous turbulent medium*, Proc. Roy. Soc. London Ser. A vol. 210 (1951) pp. 26-29.
13. G. K. Batchelor, *Pressure fluctuations in isotropic turbulence*, Proc. Cambridge Philos. Soc. vol. 47 (1951) pp. 359-374.
14. J. H. Jeans, *Astronomy and cosmogony*, Cambridge University Press, London, 1929, pp. 345-349.

A CRITICAL DISCUSSION OF SIMILARITY CONCEPTS IN ISOTROPIC TURBULENCE

BY

C. C. LIN

1. Introduction. One of the most striking properties of the turbulent motion behind a grid in the wind tunnel is that the correlation functions are more or less similar. In the theoretical analysis of the corresponding problem of decaying isotropic turbulence, von Kármán [1] introduced the concept of self-preserving correlation functions and deduced the law of decay of turbulence from it. Even when it was first introduced, it was clear that this concept of self-preservation could not be applied in a simple manner [2]. Heisenberg [3] used the corresponding concept of the similarity of the spectrum and emphasized its basic significance. A survey of the various types of similarity concepts¹ has been presented by von Kármán and the present author [4].

In the present paper, we shall concern ourselves with the two closely related concepts of similarity of the spectrum, one more stringent than the other, both of which lead to the correct law of decay of turbulence during the very first part of the decay process. The one asserts that the spectrum is completely similar during the process of decay, and the other asserts that there may be lack of similarity at the lower end of the spectrum (cases (a) and (c) in [4]). A relatively minor theoretical difficulty in the assumption of complete similarity has already been noted in Heisenberg's first analysis. Although the similar spectrum has a linear behavior at low frequencies, continuity requirements predict that the spectrum should vary with the fourth power of the wave number at the lower end. A more important question, however, is whether the turbulent motion has time enough, during the process of decay, to adjust itself to the self-preserving condition. If a considerable part of the large eddies cannot adjust itself rapidly enough, the lack of similarity must be larger than that expected from the above-mentioned cause. Indeed, the recent experiments of Stewart and Townsend [5] have led them to the following conclusion: "Within the initial period of decay, the greater part of the energy spectrum function is self-preserving, and this part has a shape independent of the shape of the turbulence-producing grid. The part that is not self-preserving contains at least *one third* of the total energy, and it is concluded that theories postulating quasi-equilibrium during decay must be considered with great caution."

¹ The concepts of self-preserving correlations and similar spectra are used in the sense in which they were first introduced by von Kármán and Heisenberg, respectively. The theory of Kolmogoroff and Obukhoff will be referred to as the theory of local similarity or as the theory of equilibrium spectrum or universal spectrum. This usage is not unanimously adopted (see Stewart and Townsend [5]).

The purpose of the present paper is an attempt to throw further light on the extent of self-preservation and the deduction of the law of decay from such concepts.²

2. Résumé of theoretical considerations. We start with the equation

$$(1) \quad \frac{\partial F}{\partial t} + W = -2\nu k^2 F$$

for the change of spectrum $F(k,t)$ with time t , where k is the wave number, $W(k,t)$ corresponds to the transfer of energy among the various wave numbers, and ν is the kinematic coefficient of viscosity. A self-preserving process is described by writing

$$(2) \quad F = V^2 l f(kl), \quad W = V^3 w(kl),$$

where $V(t)$ and $l(t)$ are reference velocity and scale, respectively. Substitution of (2) into (1) leads to the conclusion that

$$(3) \quad V^2 = At^{-1}, \quad l^2 = Bt,$$

where A and B are constants of integration. Another constant not written out explicitly is the origin of time.

The reference velocity $V(t)$ is not necessarily proportional to the intensity u' of turbulence. Hence, to obtain the law of decay, one must seek to connect $u'(t)$ with $V(t)$ and $l(t)$. This may be done in several different ways:

(A) The simplest way is to interpret (2) in the strict sense. Then one may calculate u'^2 by the formula

$$(4) \quad u'^2 = \int_0^\infty F(k) dk,$$

and substitute $F(k)$ from (2). This leads to

$$(5) \quad u'^2 = \alpha t^{-1},$$

where α is a constant of proportionality. This deduction is essentially the one given by Heisenberg.

(B) However, if one doubts whether the low-frequency components can share in the self-preserving properties of the turbulent motion at higher wave numbers, one may question the accuracy of (4). One may then wish to postulate that there may be an actual deviation from similarity at low frequencies, but that³ "the deviation shall occur only for such small values of k , that whereas the contribution of the deviation is negligible for computation of ϵ [cf. (6)], it enters in the calculation of energy [cf. (4)]."

² The views expressed here in Secs. 2 to 4 (excepting the experimental evidence) have essentially been implied or explained explicitly in [4]. They are also largely in agreement with those in [7]. But there are minor differences in emphasis. It is therefore thought desirable to give an exposition in these sections to preserve the continuity of this paper.

³ Quotation from [4].

Then the rate of energy dissipation is

$$(6) \quad -\frac{du'^2}{dt} = \epsilon = 2\nu \int_0^\infty k^2 F dk = \alpha t^{-2},$$

and we obtain

$$(7) \quad u'^2 = \alpha t^{-1} + \beta,$$

where β may be positive, negative, or zero. In the last case, (7) formally reduces to (5). The law of decay (7) was first derived in [6] from a consideration of the correlation functions.

(C) Goldstein considered the above idea and also its extensions. If the lack of similarity is so strong that even (6) is not accurate, one may still hope that (2) is accurate enough for the calculation of $\int_0^\infty k^4 F dk$ and $\int_0^\infty k^2 W dk$. One then obtains the law of decay

$$(8) \quad u'^2 = \alpha t^{-1} + \beta + \gamma t.$$

This may be further extended to higher moments, so that $u'^2 t$ will be represented by polynomials of higher degrees.

Except for the reasons indicated in Sec. 1, there is no simple argument to decide on the relative merits of the various alternatives. However, it may be remarked that if (2) is accurate only for the calculation of very high moments, the deduction of (3) from (1) and (2) may become unreliable, since $W(k, t)$ must be more or less determined by the energy-containing eddies. This point may be clearly illustrated with Heisenberg's formula for the transfer function:

$$(9) \quad W = 2\kappa \left[k^2 F \int_k^\infty \sqrt{\frac{F(k')}{k'^3}} dk' - \sqrt{\frac{F(k)}{k^3}} \int_0^k k'^2 F(k') dk' \right],$$

which contains the term $\int_0^k k'^2 F(k') dk'$. If this term cannot be accurately given by the self-preserving hypothesis for large values of k , the self-preservation of $W(k, t)$ also becomes untenable for large k , since the other terms in (9) are certainly self-preserving for large k if $F(k, t)$ is so. Thus, alternative (B) has a special position with reference to Heisenberg's formula.

We shall now turn to an examination of experimental evidence and general considerations before returning to further theoretical discussions.

3. Experimental evidence. Stewart and Townsend made several interesting findings on the decay of turbulence in the first part of the decay process by experiments performed behind several grids in the wind tunnel. In particular, the law of decay (5) was found to hold during the initial period, although the deviation from self-preservation was by no means small among the lower frequency components (see Sec. 1). In fact, it was so large that the linear part of the spectrum, first proposed by Heisenberg, was not observed. The simple decay law was also found to hold over a remarkably long period of time. The total energy of turbulence at the end of the period of experimental observation was substantially down to the level of the energy of the non-self-

preserving large eddies alone in the initial stage. On the other hand, the spectrum of vorticity k^2E was found to satisfy the self-preserving relation very closely, because the significance of the components of low frequencies is reduced by the factor k^2 relative to the self-preserving high-frequency components.

These experimental results are definitely against the assumption of complete similarity. They tend to support alternative (B) of the proposed theories.⁴ Also, there does not seem to be any necessity, at least for these experiments, to generalize the consideration as indicated in alternative (C). One remarkable fact, however, still remains unexplained; *viz.*, the additive constant β in (7) was found to be zero in all these experiments. It would be interesting, therefore, to try to find out whether there are cases of wind-tunnel turbulence which decay according to the law (7) but with $\beta \neq 0$. In this connection, it seems highly desirable that experiments with two grids, as proposed by Goldstein [7], be carried out. It will then become clear whether the fact that $\beta = 0$ is to be associated with the presence of a single grid or to be interpreted as a more general phenomenon.⁵ Theoretical investigations must then be made accordingly.

4. Physical considerations. In view of the remarkable extent of the lack of similarity in the large eddies, as revealed by the work of Stewart and Townsend and presented briefly in the last section, it might appear surprising, at first sight, that there still exists any regular law of decay, since the behavior of these large eddies presumably depends very much on how they were produced and must therefore be rather difficult to describe in a simple manner.

But this is exactly the reason why alternative (B) was proposed. It may not be necessary to investigate the behavior of the large eddies in order to obtain the rate of dissipation, which is essentially governed by the smaller eddies. These smaller eddies may be able to adjust themselves to a state of quasi-equilibrium (say, roughly by the time approximate isotropy of the turbulence is reached). Then a definite law for the *rate* of dissipation is obtained (6), and the dependence of energy on time must be given by (7). All our ignorance of the behavior of the large eddies reveals itself only in our inability to determine the additive constant β .

One may still wonder whether it is likely that the small eddies can exist in a state of quasi-equilibrium, since they must continually draw energy from the larger eddies not sharing in it. To answer this question, it is best to take one particular transfer mechanism to fix our ideas. Again, we turn to the transfer function suggested by Heisenberg. According to his formula, the rate of energy transfer from wave numbers below k to wave numbers above it is given by

$$(10) \quad S(k) = 2\kappa \int_0^k k'^2 F(k') dk' \cdot \int_k^\infty \sqrt{\frac{F(k')}{k'^3}} dk'.$$

⁴ The table on p. 383 of [5] does not list alternative (B). It also appears to contain a misprint so that alternative (A) seems to be favored, although the text and abstract definitely state otherwise.

⁵ See also p. 570 of [7], and note on page 26 of this paper.

Thus, it is clear that the low-frequency components play a less important role in deciding the transfer mechanism than the high-frequency ones, since the factor k^2 tends to obliterate the irregular behavior of the large eddies. Specifically, it is obvious from this formula that, if the spectral density $F(k)$ is self-preserving above a frequency k_0 , and if the vorticity spectrum $k^2F(k)$ is approximately self-preserving at all frequencies (wherever its contribution is significant), the transfer function $S(k)$ is also self-preserving at frequencies above k_0 . This explanation, by way of the specific form of Heisenberg's formula for the transfer function, serves only as an example of what may happen to cause the self-preservation of energy transfer. Its general validity should be regarded as suggested by the type of physical considerations underlying that formula.

One may summarize the above discussion into the following hypotheses:

1. For the frequency range $k_0 < k < \infty$, containing a substantial portion of the turbulence energy, the spectral density and the density of energy transfer⁶ are self-preserving.

2. The rate of energy dissipation may be obtained with sufficient accuracy by assuming self-preservation of the spectral density throughout.⁷

These are explicit statements, in physical terms, of alternative (*B*) of the proposed theories. At the time the theory was first proposed, the precise nature of the lack of similarity of the large eddies was not specified. The opinion has then been expressed [8] that the departure from similarity, under idealized conditions, might be attributed to the k^4 -power behavior of the spectrum at the lowest frequencies. The experiments of Stewart and Townsend show that this idealization is not realized for turbulence produced in the wind tunnel behind a single grid, but the original form of the theory, in its less specific form, is supported.

5. Stability of the quasi-equilibrium spectrum. The above discussions are based on the idea that, during the process of decay, the smaller eddies can adjust themselves into quasi-equilibrium while the larger eddies cannot. One might wonder whether, besides the experimental evidence presented above, there is any theoretical evidence for this idea. The following investigation is an attempt to throw some light on this problem:

We ask ourselves the following question: Suppose the similarity spectrum has been established, how stable will it be? That is, if a small perturbation is imposed, how fast will it die out? In particular, we would like to get an estimate of the rate of disappearance of the perturbation and compare it with the over-all rate of energy dissipation. If the former rate is much faster than the latter, one might infer that the spectrum has the ability to adjust itself to the quasi-equilibrium state during the process of decay; otherwise, it might happen

⁶ One might generalize this statement to include other suitable statistical properties, but we shall not proceed with further speculations here.

⁷ This statement is certainly valid for the very high Reynolds numbers, where the equilibrium spectrum takes care of practically all the dissipation.

that most of the decay process happens without the similarity of spectrum ever being attained.

For these purposes we adopt Heisenberg's formula for the transfer function, whose general correctness, at least for the quasi-equilibrium condition, has been experimentally supported by the experiments of Proudman [9]. We consider the equation of changing spectrum in the form

$$(11) \quad \frac{\partial}{\partial t} \int_0^k F(k, t) dk = -2 \left[\nu + \kappa \int_k^\infty \sqrt{\frac{F(k')}{k'^3}} dk' \right] \cdot \int_0^k k'^2 F(k') dk',$$

and consider a perturbation $\varphi(k, t)$ superposed on the quasi-equilibrium spectrum $F_e(k, t)$ calculated by Chandrasekhar [10]. The linearized differential equation for $\varphi(k, t)$ is

$$(12) \quad \frac{\partial}{\partial t} \int_0^k \varphi dk = -\kappa \int_k^\infty \frac{\varphi(k')}{F_e(k')} \sqrt{\frac{F_e(k')}{k'^3}} dk' \cdot \int_0^k k'^2 F_e(k') dk' \\ - 2 \left[\nu + \kappa \int_k^\infty \sqrt{\frac{F_e(k')}{k'^3}} dk' \right] \int_0^k k^2 \varphi(k) dk.$$

The solution of this linear equation can be studied in some detail. But, for the present, we shall limit ourselves to an estimation of the initial rate of disappearance of the perturbation when it occurs only as a narrow band near a frequency k_* (say). Then, if e denotes the total energy of the perturbation, (12) becomes, by putting $k = k_* + 0$ at the initial instant,

$$\frac{1}{e} \frac{de}{dt} = -2k_*^2 \left\{ \nu + \kappa \int_{k_*}^\infty \sqrt{\frac{F_e(k)}{k^3}} dk \right\}.$$

This may be compared with the over-all rate of decay

$$\frac{1}{u'^2} \frac{du'^2}{dt} = -\frac{10\nu}{\lambda^2},$$

where λ is Taylor's vorticity scale. In fact, their ratio is

$$(13) \quad \gamma(x_*) = 2x_*^2 \left[\frac{1}{R} + \int_{x_*}^\infty \sqrt{\frac{f(x)}{x^3}} dx \right],$$

where R is a Reynolds number of turbulence, related to $R_\lambda = u'\lambda/\nu$ by the equation

$$(14) \quad \frac{1}{R^2} = \frac{10}{(\kappa R_\lambda)^2} \int_0^\infty f(x) dx,$$

and $f(x)$ and x are defined by

$$(15) \quad F_e(k, t) = \frac{1}{\kappa^2 l_0^3 t_0^2} \left(\frac{t_0}{t} \right)^{\frac{1}{2}} f(x),$$

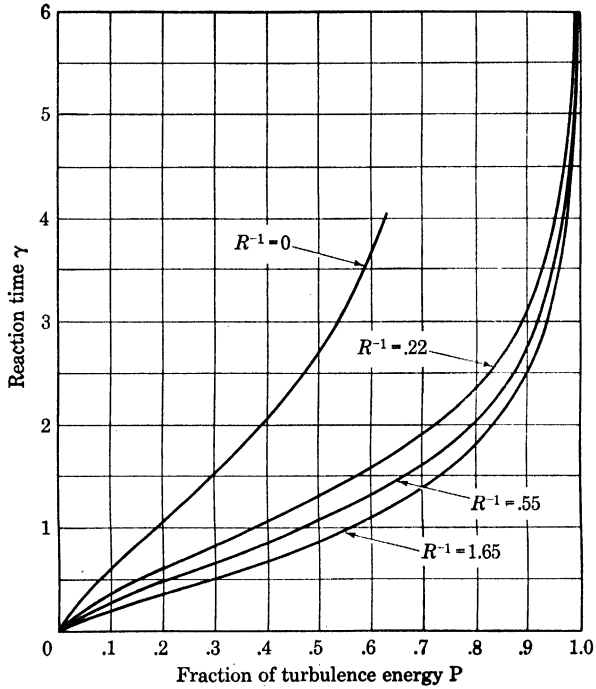

FIG. 1. "Reaction time" against fraction of turbulence energy for $R^{-1} = 0, 0.22, 0.55, 1.65$ (corresponding to $\kappa R_{\lambda} = \infty, 16, 5, 1$, approximately).

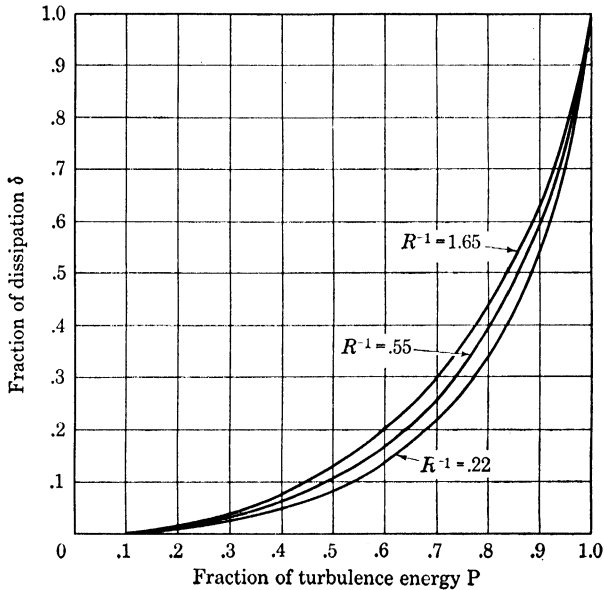

FIG. 2. Fraction of energy dissipation against fraction of energy content for $R^{-1} = 0, 0.22, 0.55, 1.65$ (corresponding to $\kappa R_{\lambda} = \infty, 16, 5, 1$, approximately).

where $x = k \sqrt{l/k_0} \sqrt{t_0}$. The function $f(x)$ satisfies the equation

$$(16) \quad \int_0^x f(x) dx - \frac{1}{2} x f = 2 \left[\frac{1}{R} + \int_x^\infty \sqrt{\frac{f(x)}{x^3}} dx \right] \int_0^x x^2 f(x) dx,$$

and has been calculated by Chandrasekhar. The function $\gamma(x_*)$ is calculated and plotted against

$$(17) \quad P(x_*) = \frac{\int_0^{x_*} f(x) dx}{\int_0^\infty f(x) dx},$$

the fraction of energy below x_* (Fig. 1). Also plotted (Fig. 2) is

$$(18) \quad \delta(x_*) = \frac{\int_0^{x_*} x^2 f(x) dx}{\int_0^\infty x^2 f(x) dx},$$

the fraction of energy dissipation below x_* . It is clearly seen that below $\gamma = 1$ there is a considerable portion of energy but only a negligible fraction of the dissipation. In fact, for most of the energy-containing range, γ is not large, unless R_λ is very high, suggesting the sluggishness of all the energy-containing eddies.

In fact, if one considers the ratio of the energy of the perturbation to the total energy,

$$q = \frac{e}{u'^2},$$

one obtains

$$(19) \quad \frac{1}{q} \frac{dq}{dt} : \frac{1}{u'^2} \frac{du'^2}{dt} = \gamma - 1$$

as a measure of its rate of disappearance.

If this ratio is negative, while γ is positive, it means that the energy of perturbation, e , is decreasing, but at a rate slower than that for the total energy. This would mean that, for $\gamma < 1$, one might expect the spectrum to be unable to reach the quasi-equilibrium state. One may note that, for medium Reynolds numbers, associated with $\gamma < 1$, the amount of energy is roughly one-third of the total and the contribution to dissipation is negligible. These results may be compared with the experimental findings of Stewart and Townsend.⁸

The author is indebted to the staff of the Numerical Analysis Laboratory, particularly Dr. L. Jacchia, for their help in making the numerical calculations.

⁸ *Note added in proof:* Upon closer examination of the experimental data of Stewart and Townsend, it is found that the two straight lines, for (λ^2, x) and (u'^2, x) respectively, do not pass through the same origin. Consequently R_λ decreases with increasing distance downstream. This indicates a definite departure from (5) for the law of decay, and gives even stronger evidence for the law (7), (with $\beta < 0$), first obtained by the present writer [6].

BIBLIOGRAPHY

1. T. von Kármán, *On the statistical theory of turbulence*, Proc. Nat. Acad. Sci. U.S.A. vol. 23 (1937) pp. 98–105; *The fundamentals of the statistical theory of turbulence*, J. Aero. Sci. vol. 4 (1937) pp. 131–138.
2. ——— and L. Howarth, *On the statistical theory of isotropic turbulence*, Proc. Roy. Soc. London Ser. A vol. 164 (1938) pp. 192–215.
3. W. Heisenberg, *On the theory of statistical and isotropic turbulence*, Proc. Roy. Soc. London Ser. A vol. 195 (1948) pp. 402–406.
4. T. von Kármán and C. C. Lin, *On the concept of similarity in the theory of isotropic turbulence*, Rev. Mod. Phys. vol. 21 (1949) pp. 516–519; *Advances in Mechanics* vol. II (1951) pp. 1–19.
5. R. W. Stewart and A. A. Townsend, *Similarity and self-preservation in isotropic turbulence*, Philos. Trans. Roy. Soc. London Ser. A vol. 243 (1951) pp. 359–386.
6. C. C. Lin, *Note on the law of decay of isotropic turbulence*, Proc. Nat. Acad. Sci. U.S.A. vol. 34 (1948) pp. 540–543.
7. S. Goldstein, *On the law of decay of homogeneous isotropic turbulence and the theories of the equilibrium spectrum and similarity spectra*, Proc. Cambridge Philos. Soc. vol. 47 (1951) pp. 554–574.
8. G. K. Batchelor, *Recent developments in turbulence research*, Proc. VIIth Int. Congr. Appl. Mech. introductory vol. (1948) pp. 27–56.
9. I. Proudman, *A comparison of Heisenberg's spectrum of turbulence with experiment*, Proc. Cambridge Philos. Soc. vol. 47 (1951) pp. 158–176.
10. S. Chandrasekhar, *On Heisenberg's elementary theory of turbulence*, Proc. Roy. Soc. London Ser. A vol. 200 (1949) pp. 20–33.

MASSACHUSETTS INSTITUTE OF TECHNOLOGY,
CAMBRIDGE, MASS.

THE NONEXISTENCE OF TRANSONIC POTENTIAL FLOW

BY

ADOLF BUSEMANN

1. Introduction. The nonexistence of transonic potential flow is not connected with its nonlinear differential equation in the physical plane, or with the difficulties in determining the physical boundary conditions, if the hodograph is used for the study of two-dimensional flow. The nonexistence of a regular solution is actually a property of the linear differential equation of the mixed elliptical and hyperbolic type and the required boundary conditions. It is therefore possible to demonstrate this fact without using any explicit flow properties or flow experiences. In order to be closer to a later application of the results to an actual flow or to reproduce my first disclosure of the nonexistence five years ago, it seems advisable to use the stream function for a two-dimensional potential flow as the unknown quantity in the hodograph plane. Disregarding the obvious exception that the stream potential behaves differently from the other functions near the sonic line, it is almost irrelevant which one of the functions is chosen for solutions with fixed boundary condition in the hodograph plane.

In order to start with the known form of the equations under consideration, the differential equations for potential flow are repeated in the following equations:

The three-dimensional potential φ in the physical space x, y, z is a solution of

$$(1) \quad (a^2 - \varphi_x^2)\varphi_{xx} + (a^2 - \varphi_y^2)\varphi_{yy} + (a^2 - \varphi_z^2)\varphi_{zz} - 2\varphi_{xy}\varphi_{xyz} - 2\varphi_{xz}\varphi_{xzx} - 2\varphi_{xy}\varphi_{xyy} = 0,$$

and the two-dimensional stream function in the physical plane x, y satisfies

$$(2) \quad (\rho^2 a^2 - \psi_y^2)\psi_{xx} + 2\psi_x\psi_{xy}\psi_{xy} + (\rho^2 a^2 - \psi_x^2)\psi_{yy} = 0,$$

with a the velocity of sound and ρ the density of the gas.

For the transformation to the hodograph or velocity plane, the Legendre potential χ is defined by the following meaning of its derivatives:

$$\chi_u = x, \quad \chi_v = y,$$

and leads to a linear differential equation

$$(3) \quad (a^2 - v^2)\chi_{uu} + 2uv\chi_{uv} + (a^2 - u^2)\chi_{vv} = 0.$$

The equations for the stream potential and the stream function are also linear in the hodograph plane and have the same terms in the derivatives of second order, because of the identical characteristics, but contain in addition terms in the derivatives of first order,

$$(4) \quad (a^2 - v^2)\varphi_{uu} + 2uv\varphi_{uv} + (a^2 - u^2)\varphi_{vv} + \frac{a^2 + \gamma(u^2 + v^2)}{a^2 - u^2 - v^2} (u\varphi_u + v\varphi_v) = 0$$

and

$$(5) \quad (a^2 - v^2)\psi_{uu} + 2wv\psi_{uv} + (a^2 - u^2)\psi_{vv} + u\psi_u + v\psi_v = 0,$$

with γ being the ratio of the specific heats, a constant for perfect gases [or $\gamma = 1 - 2 \, da^2/d(u^2 + v^2)$ for all gases].

Instead of the Cartesian coordinates u and v in the velocity plane, very often the polar coordinates w, θ are introduced and lead to the following differential equations:

$$(3a) \quad a^2 w^2 \chi_{ww} + a^2 w \chi_w + (a^2 - w^2) \chi_{\theta\theta} = 0,$$

$$(4a) \quad a^2 w^2 \varphi_{ww} + w \frac{a^4 + \gamma w^4}{a^2 - w^2} \varphi_w + (a^2 - w^2) \varphi_{\theta\theta} = 0,$$

$$(5a) \quad a^2 w^2 \chi_{ww} + w(a^2 + w^2) \chi_w + (a^2 - w^2) \psi_{\theta\theta} = 0.$$

Since all the coefficients are functions of w only, there are many ways known of distorting the polar hodograph in the w direction in order to get a similar equation with certain convenient properties. The general procedure is to introduce a function $W(w)$ in one of the polar differential equations. For the following development the change in the sign of the coefficients of the two second-order derivatives is the only interesting feature. The simplest equation for this purpose contains only two terms and a single function $t(W)$ containing all the fluid properties. This form can be achieved by the following choice of W :

$$(6) \quad W = - \int \rho w \, d\left(\frac{1}{w}\right), \quad W' = \frac{\rho}{w}, \quad W'' = - \frac{\rho}{w^2} \left(1 + \frac{w^2}{a^2}\right),$$

which leads to the following simple rigorous differential equation valid for any gas¹

$$(7) \quad \psi_{ww} + t(W)\psi_{\theta\theta} = 0, \quad t(W) = \frac{a^2 - w^2}{\rho^2 a^2}$$

Since the logarithmic relation between W and w makes W start at minus infinity for small values of w , the conventional zero of W may be chosen at the sonic velocity, where $t(W)$ has its only zero and its regular change of sign. Positive W values thus mean supersonic speeds; negative W values, subsonic. The differential equation approaches Laplace's equation as W tends to negative infinity, with $\rho \rightarrow 1$ and $t(W) \rightarrow 1$; it is elliptical in the half plane of negative W values, and it is hyperbolic in the positive half of the (θ, W) -plane.

Figure 1 gives an idea of the actual trend of the function $t(W)$ for a perfect gas, but it is not intended to give special details for practical cases. The only restriction for the following developments is that the function t has one zero at $W = 0$, with a finite continuous derivative of the first order at this point.

¹ This equation was used by Chaplygin in his memoir on gas jets published by Moscow University. See, for example, p. 96 of the English translation appearing as Technical Memorandum 1063 of the National Advisory Committee for Aeronautics.

2. Particular solutions of product type. The simple partial differential equation (7) is open to very obvious particular solutions of the product type $\psi = f(W)g(\theta)$, if the factor containing θ repeats itself proportionally after two derivations. If we take

$$(8) \quad g(\theta) = Ae^{c\theta} + Be^{-c\theta},$$

the resulting differential equation for the other factor $f(W)$ is

$$(9) \quad f'' + c^2 t(W)f = 0.$$

This ordinary differential equation of second order with the arbitrary constant c has to be investigated with respect to fixed boundary conditions, *e.g.*, two prescribed values ψ_1 and ψ_2 for ψ at W_1 and W_2 . Especially significant solutions with zeros at W_1 and W_2 are interesting as disturbances of the regular solution. For positive values of c^2 there are plenty of zeros at negative values

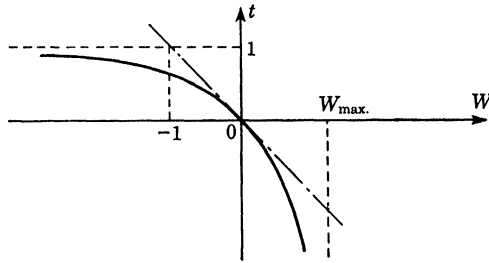

FIG. 1. The function $t(W)$.

of W , since the f curves are asymptotically sine or cosine functions. The wavelength increases somewhat toward the origin of W , since the factor $t(W)$ is lower. On the positive side of W the oscillating character of f disappears completely, leaving at most one zero or one stationary value, never two of them or one of each kind.

For imaginary values of c , corresponding to negative values of c^2 , the situation is just reversed. The subsonic side of W has at most one zero or one stationary value of f , while the oscillating character of f with numerous zeros and extremes is located on the supersonic side of W .

It is of special interest to observe that, for a given value of c , real or imaginary, the zeros and extremes on the oscillating side depend upon the location of the zero (or extreme) on the other side in a peculiar fashion. If the distance from the origin is sufficiently large (greater than the distance of the first zero on the other side), the effect of the actual location is almost negligible, since the curve arrives at the axis almost asymptotically. The location of the zero on the oscillating side thus is very sensitive, and the location on the other side extremely unsensitive, for the determination of the proper value of c and the character of the function $f(W)$.

For very high values of c the oscillatory side of f is the only interesting one; the other side shows a rapid approach to the W axis. But the oscillatory side itself is open to an approximation, the asymptotic approach.

If a function oscillates with constant amplitudes under constant conditions, the influence of changes in the controlling conditions gets a simpler universal character if the number of the oscillations grows large in a distance where the changes are still small. This universal asymptotic character can be found out of a solution for the quasi-local behavior by making its constants variable. The unknown function $f(W)$ is oscillatory wherever $c^2 t(W)$ is positive. For generality, the absolute values of the factors may be considered: $|c| = C$; $|t(W)| = T(W)$.

The oscillatory portion is therefore given by

$$(9a) \quad f'' + C^2 T(W) f = 0.$$

The quasi-local solution for constant T has a constant amplitude A :

$$(10) \quad f = A \sin (CT^{\frac{3}{2}}W).$$

Generalizing this solution for large values of C leads to a succession of quasi-local solutions with an unknown change in the amplitude $A(W)$:

$$(11) \quad f = A(W) \sin (C \int T^{\frac{3}{2}} dW).$$

This synthetic solution must satisfy the differential equation for large values of C . The second derivative gives three orders of C :

$$(12) \quad f'' = -C^2 A T \sin (C \int T^{\frac{3}{2}} dW) + C(2A'T^{\frac{3}{2}} + \frac{1}{2}AT^{-\frac{1}{2}}T'') \cos (C \int T^{\frac{3}{2}} dW) + A'' \sin (C \int T^{\frac{3}{2}} dW).$$

The largest term corresponds to the quasi-local case of constant T and is canceled by the term $C^2 T f$. The first disturbance is given by the out-of-phase term, which can be canceled by expecting the amplitudes to satisfy

$$(13) \quad \frac{A'}{A} = -\frac{1}{4} \frac{T'}{T} \quad \text{or} \quad A = T^{-\frac{1}{4}}.$$

This result may be adopted if with its application the third term containing A'' is sufficiently small. The third term sets a lower barrier for C :

$$(14) \quad C^2 \gg \frac{A''}{AT} = \frac{5T'^2 - 4TT''}{16T^3}.$$

This barrier, though usually of finite value, may assume vanishing values wherever T approaches zero or infinity with a proper power in W . For powers of W , the phase integral $\int T^{\frac{3}{2}} dW$ and the barrier for C^2 shows a remarkable relation:

If $T = W^n$,

$$(15) \quad \int T^{\frac{1}{2}} dW = \int W^{n/2} dW = \frac{2}{n+2} W^{(n/2)+1},$$

and

$$(16) \quad \frac{1}{2C} \ll \sqrt{\left| \frac{4T^3}{5T'^2 - 4TT''} \right|} = \frac{2}{\sqrt{|n| \cdot |n+4|}} W^{(n/2)+1},$$

so that when the phase integral approaches infinity more strongly than logarithmically, the barrier for C vanishes. Since the negative branch of the $t(W)$ function approaches its infinity with $(W_{\max} - W)^n$ and n above -2 [it is $(W_{\max} - W)^{-(\gamma+1)/\gamma}$], there exist a finite barrier for the C and a finite number of oscillations. The extrapolated tangent of the $t(W)$ function, however, leads

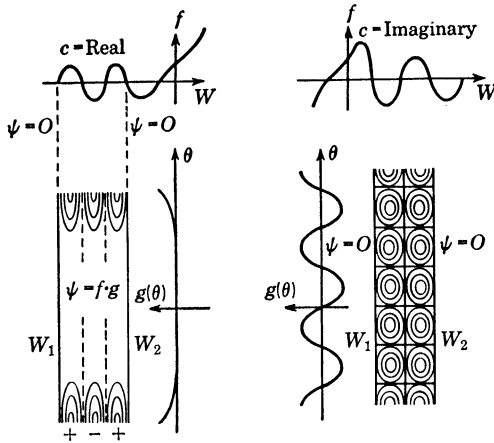

FIG. 2. Subsonic and supersonic disturbances.

to an infinite number of oscillations toward infinity and correspondingly satisfies for all values C the asymptotic power law W^{-1} for the amplitudes.

After the function f is discussed and methods of calculation in graphical or analytical form are evident, the resulting particular solutions of disturbances may be demonstrated. The typical subsonic, supersonic, and transonic disturbances are represented in Figs. 2 and 3. The main result is that the transonic flow can have both the subsonic and the supersonic types of disturbances, each type preferring, but not completely restricting itself to, its proper domain. The subsonic exponential type, entering from both ends of the strip, has very little effect in the supersonic domain; the supersonic periodic type, going through the whole strip, in its turn fades out in the subsonic domain. For very narrow strips for which the tangent of the $t(W)$ function replaces the exact values satisfactorily (transonic similarity!), the mutual penetration is controlled by identical $f(W)$ functions with reversed W direction, if W_1 equals $-W_2$ or if W_1 and W_2 are replaced at the same time by $-W_2$ and $-W_1$. If the calm region is wide enough, the exact value of its width becomes irrelevant,

and the limiting function having its zero value on the calm side in infinity is as good as the proper one. This limiting function for a linear $t(W)$ has a standard

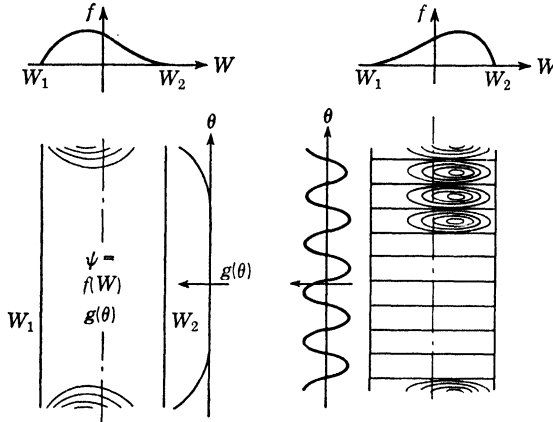

FIG. 3. The subsonic and supersonic types of disturbances in mixed flows.

form which is defined by the differential equation

$$(17) \quad F''(\eta) + \eta F'(\eta) = 0,$$

and two boundary conditions $F(-\infty) = 0$ and $F(0) = 1$. It can be expressed in the first kind of Hankel functions of the order $\frac{1}{3}$:

$$F(\eta) \sim \eta^{\frac{1}{2}} H_{\frac{1}{3}}^{(2)}(\frac{2}{3}\eta^{\frac{2}{3}}).$$

Its zeros η_n have fixed values on the positive real axis of η . The character of F , though not too important in its details for the nonexistence theorem, is given in Fig. 4.

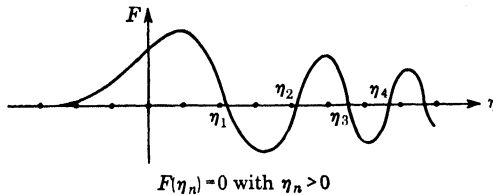

FIG. 4. Standard form of F .

3. A more general type of particular solution. Though the strip solutions show very important features of the nonexistence theorem, if discussed with respect to their proper boundary conditions, they still are too simple to unveil the full dilemma. The corresponding flow solutions were given by G. I. Taylor [2] as early as 1930. A sufficiently general type of particular solution requires a change in the width of the supersonic zone. Since this is all that is required, any helpful simplification which would not change this goal may be applied. The interesting effects can be expected by the squeeze of the super-

sonic zone between the border and the sonic line when the zone approaches zero width. In this case the supersonic disturbances are highly oscillating in the θ -direction and increase their number of periods rapidly with the squeeze, as in Fig. 5, thus indicating that an asymptotical approach is appropriate.

For small width of the supersonic zone in a strip, the function f can be simplified by taking the tangent of $t(W)$ instead of the exact values. If the subsonic border line at W_1 is much farther from the sonic line than all the values W_2 on the supersonic side under consideration, the simplified function f may even be replaced by the standard function F mentioned above. With these justified simplifications the quasi-local solution for a width W_2 of the supersonic zone is given by

$$(18) \quad AF(C^{\frac{1}{3}}W) \sin C\theta.$$

This solution satisfies the differential equation

$$(19) \quad L(\psi) = \psi_{ww} - W\psi_{\theta\theta} = 0,$$

since by definition

$$(17a) \quad F''(C^{\frac{1}{3}}W) + C^{\frac{1}{3}}WF(C^{\frac{1}{3}}W) = 0,$$

and F vanishes sufficiently at the subsonic side and has all its exact zeros η_n at fixed positive values. C is given, for instance, by

$$(20) \quad C^{\frac{1}{3}}W_2 = \eta_n \quad \text{or} \quad C = \left(\frac{\eta_n}{W_2}\right)^{\frac{3}{2}}.$$

If this quasi-local solution is prolonged at changing values $W_2(\theta)$ and corresponding values $C(\theta)$, the proper generalization is

$$(21) \quad \psi_1 = A(\theta)F[C(\theta)^{\frac{1}{3}}W] \sin(\int C d\theta).$$

Considering large values of C , the two second-order derivatives may be arranged as follows:

$$(22) \quad \psi_{1ww} = C^{\frac{1}{3}}AF'' \sin(\int C d\theta) = -C^2AWF \sin(\int C d\theta),$$

$$(23) \quad \psi_{1\theta\theta} = -C^2AF \sin(\int C d\theta) + C(2A'F + \frac{4}{3}AWF'C^{-\frac{1}{3}}C' + AFC^{-1}C') \cos(\int C d\theta) + (\cdot \cdot \cdot) \sin(\int C d\theta),$$

so that, from (19),

$$L(\psi_1) = -CW(2A'F + \frac{4}{3}AWF'C^{-\frac{1}{3}}C' + AFC^{-1}C') \cos(\int C d\theta) - W(\cdot \cdot \cdot) \sin(\int C d\theta).$$

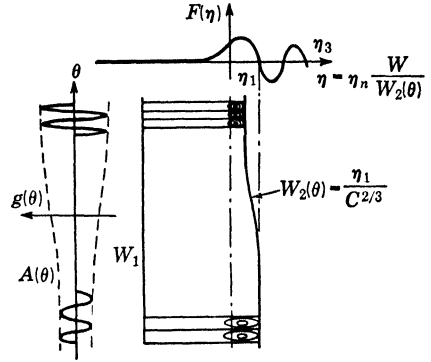

FIG. 5. Supersonic type of disturbances at variable distances $W_2(\theta)$.

In order to cancel the out-of-phase term, an additional function ψ_2 , which does not violate the boundary conditions, will be added to ψ_1 . Multiplying the out-of-phase terms with W and integrating them twice with respect to W shows that a second term ψ_2 may be tried having the form

$$(24) \quad \psi_2 = \frac{2}{3}AW^3FC' \cos(\int C d\theta),$$

since the factor F guarantees the boundary conditions (not F'). This additional term has the second-order derivatives in corresponding orders:

$$(25) \quad \psi_{2WW} = \frac{4}{3}\left(\frac{1}{6}C^3AW^3F''C' + C^3AW^2F'C' + AWF C'\right) \cos(\int C d\theta),$$

$$(26) \quad \psi_{2\theta\theta} = -\frac{2}{3}AC^2C'W^3F' \cos(\int C d\theta) - C(\cdot \cdot \cdot) \sin(\int C d\theta) \\ + (\cdot \cdot \cdot) \cos(\int C d\theta),$$

and consequently

$$L(\psi_2) = \frac{4}{3}ACW(WC^{-3}C'F' + C^{-1}C') \cos(\int C d\theta) + CW(\cdot \cdot \cdot) \sin(\int C d\theta) \\ - W(\cdot \cdot \cdot) \cos(\int C d\theta).$$

If we set $\psi = \psi_1 + \psi_2$, we find

$$L(\psi) = 2AFCW \left(\frac{1}{6} \frac{C'}{C} - \frac{A'}{A} \right) \cos \left(\int C d\theta \right) + \dots,$$

the first term of which drops out, provided that the amplitude A changes as follows:

$$(27) \quad \frac{A'}{A} = \frac{C'}{6C} \quad \text{or} \quad A = C^{\frac{1}{6}} = \eta_n^{\frac{1}{6}} W_2^{-\frac{1}{6}}.$$

The remaining terms are truly small if W_2 approaches the sonic line in such a manner that the phase integral $\int C d\theta$ is more than logarithmically infinite. The last dubious case is the logarithmic infinity for $C = \theta^{-1}$ or $W_2 = \theta^{\frac{1}{2}}$. It represents a rather blunt approach of the sonic line, being a semicubic parabola, similar (necessarily!) to the characteristics in supersonics. All smoother approaches, especially the linear approach, are well inside the validity of the asymptotic result. This result shows an unlimited increase of the amplitudes of any disturbance approaching the sonic line.

4. The nonexistence theorem. The rigorous result that the supersonic type of disturbance grows beyond any finite limit in a squeeze between the border and the sonic line is the basis of the nonexistence theorem. All that is left is a logical connection of the disclosed properties.

A review of the well-known properties of the pure subsonic and pure supersonic cases may serve as a starting point. The necessity of attacking the pure subsonic case as a boundary-value problem is clearly indicated by the two almost independent disturbances on the two extreme ends of a long strip (Fig. 6a). There is no chance to discover the amplitude of each of these disturbances except by known values near enough to these ends. The pure supersonic case leads to regular solution as an initial-value problem (Fig. 6b). The function and its normal derivative on one end of the strip are

sufficient to control the oscillating disturbance, whereas half the information on both ends is not sufficient. If the length of the strip happens to be an integer multiple of the period, the phases on both ends are equal, and the values are therefore identical. Identical values on both ends do not settle the positions of the nodal line; proportional values are contradictory and lead to infinite amplitudes with nodal lines at both ends, thus escaping by indefinite values (zero times infinity).

The transonic parallel strip has both types of disturbances and hence requires both types of boundary conditions with their proper locations (Fig. 6c). A one-valued boundary condition all along the subsonic border and a two-valued initial condition on one end of the supersonic zone with a free

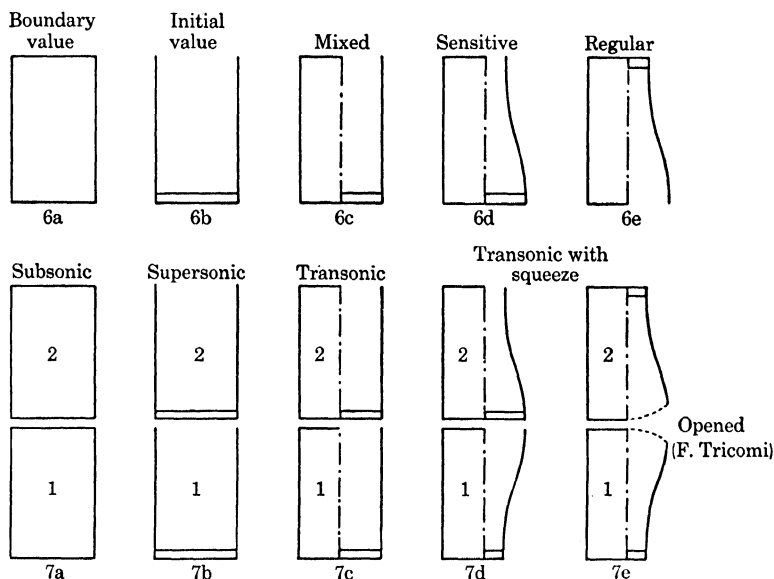

FIGS. 6 and 7. (6a-e) Adequate boundary conditions. (7a-e) Unifications.

opposite supersonic end exactly fit the most obvious necessities. If these boundary conditions do not control the regular solutions, there is hardly any hope for an existence theorem.

The increasing values of supersonic or periodic disturbances in a squeeze require even more care (Fig. 6d and e). The smaller one of the two supersonic ends becomes, the more appropriate it will be to start with known values on that side instead of working up to them from the other side. Limited values on a shrinking supersonic end freeze the flexibility on the larger end asymptotically to zero. This means that a closed supersonic wedge with the condition of a finite solution on the tip eliminates the flexibility of the free end.

The second problem for investigating the adequate boundary conditions for a differential equation of second order is the unification of two portions without discontinuities on the joint (Fig. 7). The necessary two free functions may

be given by one free function on each side, as in subsonics, or by two free functions on one side only, as in supersonics, where the second portion matches its initial values to the end of the first portion. The transonic case is a proper combination of the two simple ones as long as there is not more than one squeeze in the supersonic regimes. The transonic problems with two squeezes, if joined as shown in Fig. 7*d*, have a reduced flexibility on the wider ends and resist in the limit any continuous unification. F. Tricomi [1], who investigated almost thirty years ago the solutions of mixed differential equations, realizing the stiffness of the two supersonic ends at the junction, found a perfect way to eliminate this trouble without giving up the regularity of the solutions in both supersonic tips. He could prove the existence and uniqueness

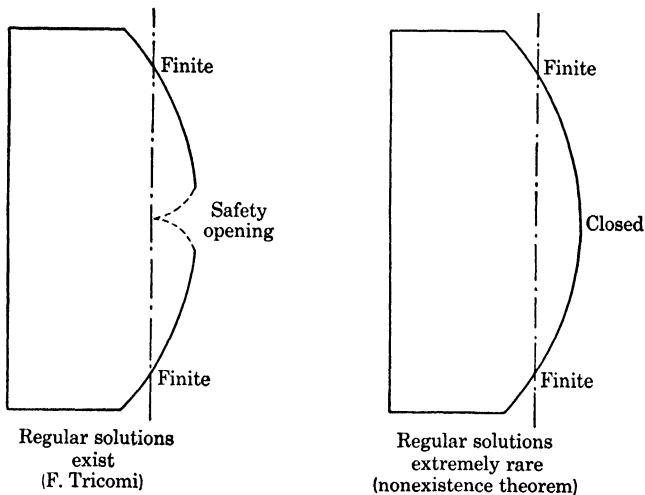

FIG. 8. Transonic flow with entrance and exit corners.

of regular solutions if the supersonic border line is opened up at the joint to relieve the two families of characteristics which cross the joint. This safety valve of Tricomi is sufficient for the existence, and something like it, on the other hand, is even necessary for keeping the solutions regular. If a supersonic portion of crescent shape has given boundary values everywhere around and is expected to be regular in the tips, the existence of solution is a rare chance (Fig. 8). Since the regularity of the hodograph solution is necessary for a potential flow and since the transformation, though not linear in the boundary conditions, is in no way selective with respect to the rare and sporadic coverage of existing solutions in the hodograph plane, it is hardly necessary to point out that the nonexistence theorem in the physical plane is the result of this nonexistence result in hodograph. The discussion of selective boundary conditions and of free sections of the body shape in order to guarantee potential flow of transonic type is already published in the author's first paper [3] about the drag problem at high subsonic speeds. It was the intention of the present

paper to bring the basic idea free from the flow experience and from the engineer's viewpoint of attack, as far as this seems possible.

5. Conclusions. A rather elementary study to find the boundary conditions compatible with transonic potential flow discloses an important departure from the natural boundary conditions of a nonviscous flow past a given body. The natural way is that the body shape is given and that the flow pattern adjusts itself to the body, but the transonic potential flow is not flexible enough to follow an arbitrary body shape all around. In the transonic potential flow a finite portion of the body surface must be reserved for counterbalancing, by means of a resultant closing curve, all the excitation within the flow initiated in following the given, not trivial, shape of the rest of the surface. The transonic flow shares with the supersonic flow the condition that the body shape gets a combination of free and resultant curves for the achievement of special aims. The Laval nozzle for an exact parallel flow and the biplane of exactly zero drag are well-known examples. A transonic potential flow cannot exist, of course, when the resultant closing curve degenerates into loops or cusps, as is generally acknowledged, but the nonexistence is equally certain when the given body shape deviates, however minutely, from any nondegenerate closing curve. The counterbalancing portion of the surface would require an endless touch-up process in order to balance the flow ideally. It is this supersensitive-ness of balancing shapes that makes the transonic potential flow past bodies of general shape nonexistent and the rising flood of transonic potential flows past large groups of (balanced!) bodies unrealistic and, therefore, deceiving.

BIBLIOGRAPHY

1. F. Tricomi, *Sulle equazioni lineari alle derivate parziali di 2° ordine, di tipo misto*, Atti Accad. Naz. Lincei Ser. 5a vol. 14 (1923) pp. 134-247 [available as Translation A9-T-26, Brown University (1948)].
 ———, *Ancora sull'equazione $y z_{zz} + z_{yy} = 0$* , Atti Accad. Naz. Lincei Ser. 6 vol. 6 (1927) pp. 567-571.
 ———, *Ulteriori ricerche sull'equazione $y z_{zz} + z_{yy} = 0$* , Rend. Circ. Mat. Palermo vol. 52 no. 1 (1928) pp. 63-90.
2. G. I. Taylor, *The flow of air at high speeds past curved surfaces*, R. & M. 1381, British ARC (1930).
 ———, *Strömung um einen Körper in kompressibler Flüssigkeit*, Zeit. Angew. Math. Mech. vol. 10 (1930) pp. 334-345.
 ———, *Recent work on flow of compressible fluids*, J. London Math. Soc. vol. 5 (1930) pp. 224-240.
3. A. Busemann and G. Guderley, *The problem of drag at high subsonic speeds*, Rep. and Translation 184, British MOS (A) Volkenrode (March, 1947).
4. A. Busemann, *The problem of drag at high subsonic speeds*, J. Aero. Sci. vol. 16 no. 6 (June, 1949). A condensation of [3].

ON WAVES OF FINITE AMPLITUDE IN DUCTS¹

BY

R. E. MEYER

The flow of an inviscid perfect gas in a duct of varying cross section is investigated under the assumption that the area of cross section changes slowly enough for the variation of the velocity over any cross section to be negligible.

The duct may have one or more throats, or no throat at all. It is assumed that a steady shock-free flow has been set up, which may be partly subsonic and partly supersonic, or entirely subsonic, or entirely supersonic. An example is the flow in a nozzle, or the steady shock-free flow in a diffuser decelerating the gas from supersonic to subsonic speed, the stability of which is investigated.

From time $t = 0$ onward, a disturbance is set up, either at the entry or at the exit of the duct, in such a way that a shock wave is not formed immediately. The disturbance gives rise to two waves, one "advancing" and the other "receding," with respect to the moving fluid. If the steady flow is supersonic, both waves move downstream, with respect to an observer at rest; if it is subsonic, the advancing wave moves downstream, and the receding wave moves upstream (see Fig. 1 for the case of a disturbance at the exit of the duct when the steady flow near the exit is subsonic, and Fig. 2 for a disturbance at the entry when the steady flow near the entry is supersonic; in both figures it is assumed that the steady flow reaches sonic speed in the throat). Even if the waves interact initially with one another, they separate after a finite time, if the disturbance is of finite extent and duration, and the present investigation is concerned with the individual waves, after they have separated.

If the duct had constant cross section, so that the flow would be strictly one-dimensional, the waves would be "simple waves." Owing to the variation of the area of cross section, the waves are continuously distorted. The process of distortion is accompanied by one of refraction, by which each of the primary waves generates a secondary wave. Thus the receding wave generates a secondary, advancing wave, which interacts with the primary wave, gets itself distorted as it moves downstream and, by the accompanying refraction, contributes to the primary wave.

The part of a wave that is most easily investigated is the wavefront traveling into steady flow. It is seen from Figs. 1 and 2 that any disturbance gives rise to two such wavefronts, and on these the equations of motion can be integrated *exactly*, if the disturbance causes a discontinuity, across the wavefront, of the local rate of change of pressure. Then the local rate of change of

¹ Abstract. A full account of the theory, in two parts, will be found in *Quart. J. Mech. Appl. Math.* vol. V (1952) pp. 257-291.

pressure, and the fluid acceleration, are discontinuous across the wavefront at all times, and the variation with time of the magnitude of the discontinuity can be found.

To explain the results, it is convenient to classify the wavefronts in two different ways. First, we may distinguish compression wavefronts and expansion

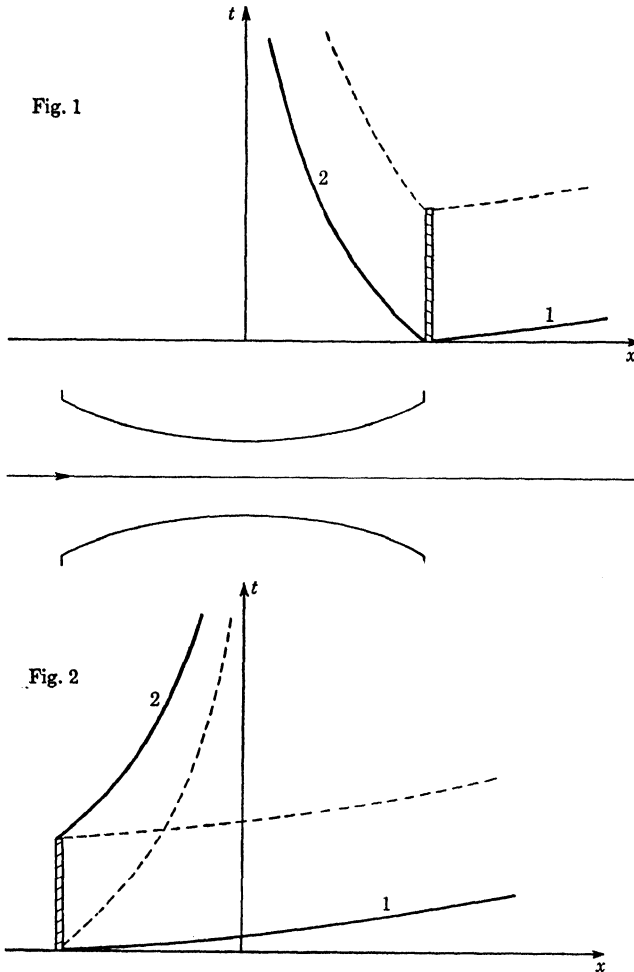

Figs. 1 and 2. (1) Advancing wavefront; (2) receding wavefront in diffuser flow.

wavefronts. A compression wavefront is one raising the local rate of change of pressure as it passes a section of the duct. Any compression wavefront shows at least an initial tendency to form a limit point, and hence a shock. Any expansion wavefront, on the other hand, shows at least an initial tendency opposed to shock formation. If it travels into a steady flow with acceleration in the stream direction, as in a nozzle, it shows a permanent tendency for the discontinuity to decrease in magnitude. But if it travels into a steady decel-

erating flow, the tendency is toward a discontinuous transition from the local pressure gradient of the original steady flow to the *opposite* pressure gradient.²

Second, we must distinguish between wavefronts that pass out of the duct after a finite time and wavefronts that approach asymptotically a sonic throat of the duct. All advancing wavefronts pass out of the duct after a finite time, but not all receding wavefronts. In a nozzle the receding wavefronts do not enter the duct at all, but in a diffuser all receding wavefronts approach the throat asymptotically. It is found that the tendencies mentioned above are permanent for all wavefronts thus caught in a duct. In particular, all compression wavefronts lead to formation of a limit point, and hence a shock, after a finite time. For wavefronts passing out of the duct, these tendencies may, under certain circumstances, succumb to other tendencies after the wavefront has passed a throat.

The exact solution found for the wavefront also applies with arbitrary accuracy to a sufficiently narrow Mach line strip adjacent to the wavefront, even if the fluid acceleration is not discontinuous across the wavefront. The theory suffices to explain the instability of steady, shock-free diffuser flows. This instability is due not so much to the "accumulation of disturbances," which is a property (due to the nonlinear terms in the equation of motion) of all compression wavefronts, whether in nozzles or in diffusers, but to the fact that in diffuser flows all receding wavefronts and, for sufficiently small disturbances, also their shocks [2] are caught in the duct. Similarly, all steady flows are unstable that are entirely subsonic, or entirely supersonic, except when sonic speed is just reached in a throat. In nozzles, on the other hand, all wavefronts, as well as the shocks to which they may lead, are blown out of the duct immediately.³

The present stability investigation is, in a sense, complementary to that of Kuo [3]. On the one hand, Kuo's investigation is more general, since it concerns two-dimensional unsteady flows. On the other hand, the present investigation is more general, since no transonic approximation is involved and it appears that the problem need not strictly be considered as a transonic problem.

In the following, attention will be confined to waves traveling into steady flows that are stable.

The results obtained for wavefronts are of further interest, since they lead, for certain types of waves, to an approximate solution valid even at considerable distances from the wavefront. The physical basis of the approximation is that the primary wave travels into steady flow and that the process of refraction is a continuous one, so that the secondary wave is built up only gradually from zero strength at the wavefront.

More precisely, assume that the disturbance is of finite extent and duration

² This remarkable result was first suggested by Kantrowitz [1].

³ The importance of the "trapping" of certain waves was first recognized by Kantrowitz [1].

and that the differences between the velocity and pressure and their respective local values in the steady flow are small, in so far as they are directly generated by the disturbance or built up during the initial interaction of the primary waves. It can then be shown that they will remain small of the same order during the time that the primary wave spends in the duct. For definiteness, consider a primary wave generated by a disturbance at the exit of a duct and receding into steady subsonic flow (Fig. 1). The primary effect of distortion of such a wave is found to be characterized by the distribution in the wave of

$$\Delta\sigma \equiv \left[\frac{\partial}{\partial t} + (u + a) \frac{\partial}{\partial x} \right] \left[\frac{a - A}{\gamma - 1} - \frac{1}{2} (u - U) \right],$$

where u and a denote, respectively, the velocity and the local speed of sound, U and A are their local values in the steady flow, and γ is the ratio of the specific heats. If $(u - U)/U$ and $(a - A)/A$ are neglected, the distribution of $\Delta\sigma$ can be found by an integration along the receding Mach lines starting from the exit; in fact, $\Delta\sigma$ is given by the formula that holds on the wavefront. This constitutes the first approximation, which yields the approximate distribution of the fluid acceleration and the local rate of change of pressure, and also the approximate equation of the limit lines. A limit line is indeed found to cross each strip of receding Mach lines in which the local rate of change of pressure, $\partial p/\partial t$, is positive at the exit, and the limit point occurring at the earliest time lies on the receding Mach line on which $\partial p/\partial t$ attains its highest value at the exit.

Knowledge of the approximate distribution of $\Delta\sigma$ permits us to calculate, to the first order, the velocity corrections $u - U$ and $a - A$ by an integration along advancing Mach lines, starting from the wavefront. This constitutes the second approximation. Whereas the value of $\Delta\sigma$ at any point in the wave is completely determined by the value of $\Delta\sigma$ at the exit, on the same receding Mach line, the velocity corrections are found to depend also on all prior values of $\Delta\sigma$ at the exit. The strength of the secondary, refracted wave is found to be small even compared with the velocity corrections.

The second approximation also yields the shock path, to the first order in the shock strength. It is interesting to note that the equations for the shock are formally identical with those first discovered by Whitham in an investigation of the steady supersonic axisymmetrical flow past slender bodies of revolution [4]. The physical basis of both theories is the same, but the mathematical approach is quite different. Whitham's theory was developed from a linearized theory of a nearly uniform flow by a process of uniformization, whereas in the problem studied here not even the basic flow is uniform, and the theory was developed directly from the nonlinear equations of motion. These two investigations would appear to be examples of a type of approximate theory more naturally adapted than linearized theory to the nonlinear, hyperbolic problems of gas dynamics. It appears to the present author that the main feature distinguishing this type of theory from linearized theory is that,

whereas the perturbation velocities are assumed to be small, no assumption at all is made about their derivatives. It is found that even if the derivatives are initially small, they may become large in due course; shock waves will ensue, and the theory will yield the approximate shape of the shock, in addition to the main results of linearized theory.

BIBLIOGRAPHY

1. A. R. Kantrowitz, *The formation and stability of normal shock waves in channel flows*, NACA Tech. Note 1225 (1947).
2. ——— and C. duP. Donaldson, *Preliminary investigation of supersonic diffusers*, NACA Adv. Confid. Rep. L5D20 (1945).
3. Y-H. Kuo, *On the stability of two-dimensional smooth transonic flows*, J. Aero. Sci. vol. 18 (1951) pp. 1-6.
4. G. Whitham, *The flow pattern of a slender projectile*, Comm. Pure Appl. Math. vol. 5 (1952) pp. 301-348.

INSTITUTE FOR FLUID DYNAMICS AND APPLIED MATHEMATICS, UNIVERSITY OF MARYLAND,
COLLEGE PARK, MD.

(ON LEAVE FROM UNIVERSITY OF MANCHESTER, MANCHESTER, ENGLAND)

ON THE PROBLEM OF SEPARATION OF SUPERSONIC FLOW FROM CURVED PROFILES

BY

T. Y. THOMAS

1. Introduction. There exists a sharp rise in the pressure on a curved profile (airfoil) in a supersonic stream with laminar boundary layer which is not predicted by the usual theory of pressure distribution. Following this pressure increase, the flow separates from the surface, after which the pressure remains constant or nearly constant over the remainder of the profile. Moreover the shock which occurs at the rear of the profile is not attached to the end vertex but is separated from the profile and displaced in the direction of the stream. These facts are indicated in Fig. 1, in which AB represents the small interval of increasing pressure. Separation occurs at point B ; the shock at the rear of the profile is represented by CD , and CE is a streamline behind the

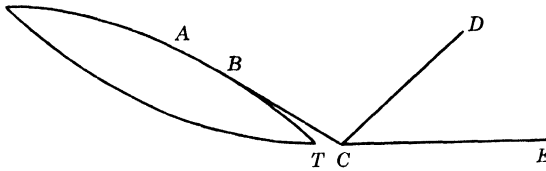

FIG. 1

shock. Between point B and the tail vertex T the pressure is practically constant.

It is immediately evident that an explanation of the above facts involves certain inherent difficulties. As mentioned above, these pressure effects are associated with the existence of a laminar boundary layer. But the distribution of pressure over the profile enters as one of the boundary conditions in the theory of the boundary layer and is, in fact, usually determined under the assumption of irrotational flow. On the other hand, if we attempt to calculate the pressure distribution based on irrotational flow, without regard to other considerations, separation can be made to occur at any assigned point of the profile, and the problem becomes indeterminate. We have attempted here to meet this situation by certain assumptions on the nature of the flow during the separation process (Sec. 2). Comparison of pressure calculations based on this theory with the experimental results of A. Ferri [1] shows good quantitative agreement. Further experimental work is obviously needed. Such measurements may possibly indicate limitations on the domain of application of our assumptions or show deviations in the nature of the flow under certain experimental conditions which will require a modification of the basic assumptions (see Sec. 4).

Calculations are based in part on the standard method of pressure determination for expansive or compressive flow [2]. Denoting the Mach angle by μ and the inclination of the profile by ω , we then have relations of the form

$$\begin{aligned} (1) \quad & \omega - \omega_v = f(\mu) - f(\mu_v), & \text{(expansive flow),} \\ (2) \quad & \omega - \omega_v = f(\mu_v) - f(\mu), & \text{(compressive flow),} \end{aligned}$$

where ω_v and μ_v denote values at the vertex of the profile; here ω_v is given by the geometry of the profile, and μ_v is determined by the shock conditions under the assumption that at the vertex there exists a shock wave (not shown in Fig. 1). By means of a table of values of the function $f(\mu)$, these relations permit the determination of the Mach angle μ at any point of the profile. After the determination of μ along the profile, the pressure ratio p/p_1 is immediately found from the formulas

$$\frac{p}{p_1} = \frac{p}{p_v} \cdot \frac{p_v}{p_1}, \quad \frac{p}{p_v} = \frac{g(\mu)}{g(\mu_v)},$$

where p denotes pressure along the profile and p_1 is the pressure of the free stream in which the profile is immersed. In the above equation $g(\mu)$ is a known function whose values have been tabulated, and the ratio p_v/p_1 is found from the shock conditions.

The usual pressure calculation involves only the relation (1) for expansive flow. In the present theory the relation (2) for compressive flow enters in connection with the determination of the back-pressure interval AB shown in Fig. 1.

2. Continuity and separation assumptions. It will be assumed that *pressure, density, and velocity along the profile are continuous functions of the arc length*. As a matter of fact, the condition that any one of these functions be continuous would imply the continuity of the others on account of the relations between these hydrodynamical quantities.

It will be found in consequence of the above continuity assumption, and the following separation assumptions, that the pressure calculation must be carried out in part on the basis of the relation (1) for expansive flow and in part on the basis of the relation (2) for compressive flow. This gives rise to the possibility of a shock, separating the regions corresponding to these two types of flow, of which there is some indication in the photographs [1]. Any such shock cannot extend to a point on the profile in the case of an actual viscous fluid, since the velocity will not be supersonic in a sufficiently small region about the profile, and this circumstance appears in close agreement with the above assumption of continuity along the profile. It must be borne in mind, moreover, that the simple irrotational flow of expansive or compressive type cannot strictly exist in the region about the profile and that our pressure calculations along the profile, based on this simple model, are intended only as approximations. In fact, from the curvature of the profile we can deduce as a mathematical consequence the curvature of the shock line which is associ-

ated with the front vertex as well as the rotational character of the flow in the region behind this shock line.

The separation of supersonic flow from a curved profile is thought to have its origin in conditions existing at the rear of the profile. These conditions are effectively contained in the following italicized assumptions, but, before stating them, it will be helpful to make certain preliminary remarks.

It will be assumed that behind the front vertex of the profile the pressure ratio p/p_1 (as well as the corresponding density ratio ρ/ρ_1 , etc.) can be calculated, to the extent permitted by the following separation assumptions, as for a flow of expansive type. After separation effects occur, the ratio p/p_1 so calculated does not retain its physical validity and will consequently be designated by the term *virtual*. Similarly, we may speak of the *virtual density ratio* ρ/ρ_1 , the *virtual Mach angle* μ , etc. These virtual magnitudes will enable us to express, in a certain sense, rear conditions of significance in the separation problem. The complete set of separation assumptions is as follows:

1. *When separation occurs, the flow leaves the profile along the tangent at the point of separation.*

2. *The pressure is constant along the tangent streamline at the point of separation, and the pressure on the profile behind the separation point is approximately equal to this constant pressure.*

3. *After separation there occurs at the rear of the profile a shock possessing the following properties: (a) the flow behind the shock is parallel to the undisturbed flow, and (b) the direction of the flow behind the shock forms with the shock line at its vertex an angle which is equal to the virtual Mach angle at the point of separation.*

4. *In the actual flow the Mach angle μ at the point of separation is equal to the arithmetic mean of the Mach angle for the undisturbed flow and the virtual Mach angle μ at the tail of the profile.*

Naturally the above assumptions are intended only as quantitative approximations to conditions existing in the actual flow. In the following section we shall apply this theory to the GU2 and GU3 profiles for which experimental data are available [1]. It will be found that the separation effects obtained, when considered in themselves, *i.e.*, apart from errors due to the standard calculation (Sec. 1) on which these effects also depend, are much better quantitatively than results based on the standard calculation along that part of the profile where such calculations apply.

3. Comparison of theoretical and experimental pressure graphs for the GU2 and GU3 profiles. The cross section of the GU2 profile consists of two circular arcs, while that of the GU3 profile is formed by a circular arc and its secant. These profiles are shown in Figs. 2 and 3 with their relative dimensions. Calculations based on the above assumptions for the GU2 profile at $M = 2.13$, where M is the Mach number of the free stream, and for the GU3 profile at $M = 1.85$ and 2.13 specifically yield the final pressure on the profile (*i.e.*, the constant pressure over the interval BT in Fig. 1), the point of separa-

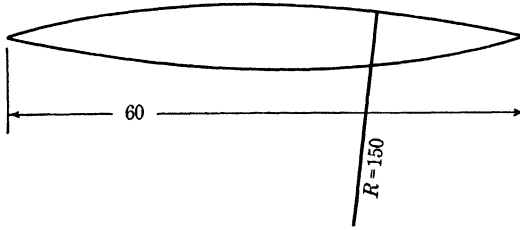

FIG. 2

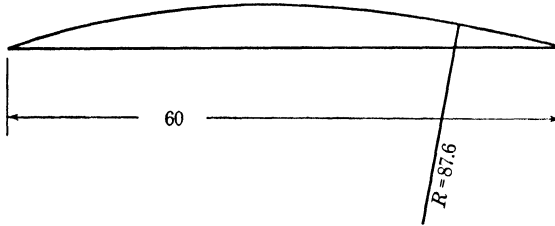

FIG. 3

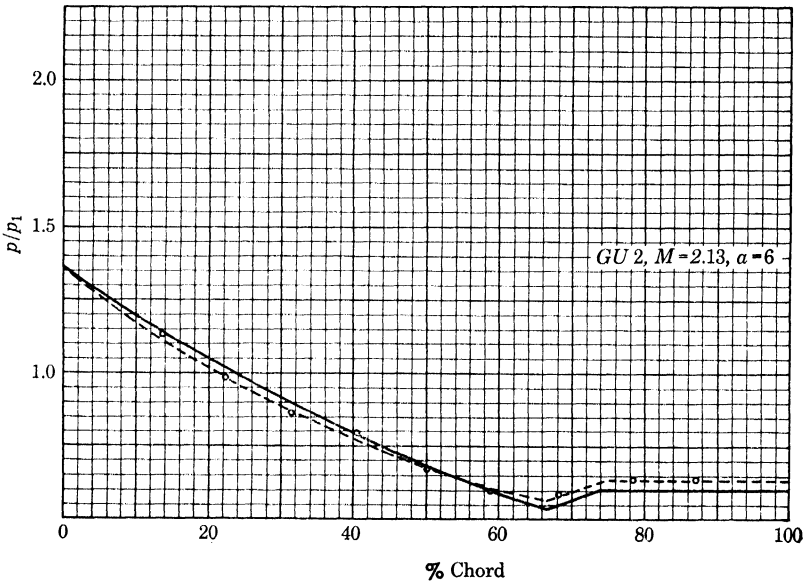

FIG. 4

tion B , and the back-pressure interval AB over which the pressure increases abruptly. These calculations have been carried out in detail elsewhere [3] and will not be given in this survey.

Typical pressure graphs in which the ratio p/p_1 is plotted against the per cent chord of the profile, with α denoting the angle of attack, are shown in Figs. 4 and 5. In these figures dashed lines represent experimental graphs, and solid lines represent calculated graphs. The differences between the final

calculated and experimental pressures are, in general, almost precisely equal to the differences in these quantities when back pressure begins effectively to develop. Since the part of the calculated pressure graphs before the back-pressure interval depends on the standard pressure calculation, this observation strongly suggests that an improvement in the standard procedure would automatically improve the determination of pressure after separation. In order to test this hypothesis, we have extended the experimental pressure graph for the GU3 profile with $M = 2.13$ and $\alpha = 0$ in a natural way to obtain the curve shown at the top of Fig. 6. When this extended curve was used to

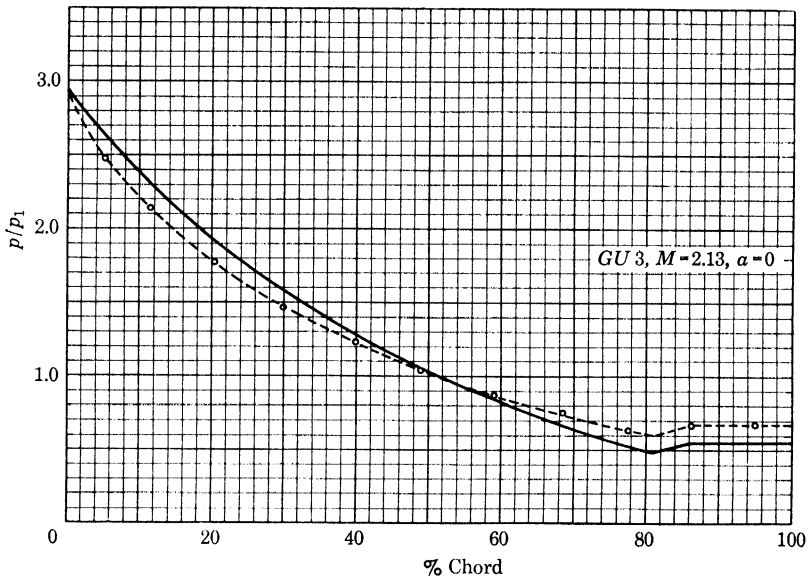

FIG. 5

determine separation effects in place of the complete pressure graph, obtained by the standard procedure, the calculation yielded the pressure graph shown at the bottom of Fig. 6, which passes accurately through all experimental pressure values. In fact, for the case under consideration the experimental value of the final pressure ratio p/p_1 is 0.681, while the value 0.684 for this ratio was obtained by this calculation.

4. Need for further experimental work. Measurements on the GU2 profile for $M = 1.85$ show a slight increase in pressure beyond the separation point, whereas in the case of the same profile for $M = 2.13$ (as well as the profile GU3 for $M = 1.85$ and 2.13) constant values of the pressure after separation were found [1]. This suggests the possibility of significant deviations from the flow pattern specified by assumptions 1 and 2 when the Mach number M is decreased sufficiently in the case of any given profile. Further experimental work is needed to clarify this situation.

The influence of conditions at the rear of the profile on the separation of flow is contained in the above assumption 4. In spite of the good agreement with experimental measurements obtained by application of this assumption, a more or less direct test of its validity would appear advisable. This can be done quite simply as follows: Construct two profiles of the type GU3 formed by circular arcs having the same radius but with secants of different lengths. Place these in the same free stream, *i.e.*, free streams with the same Mach

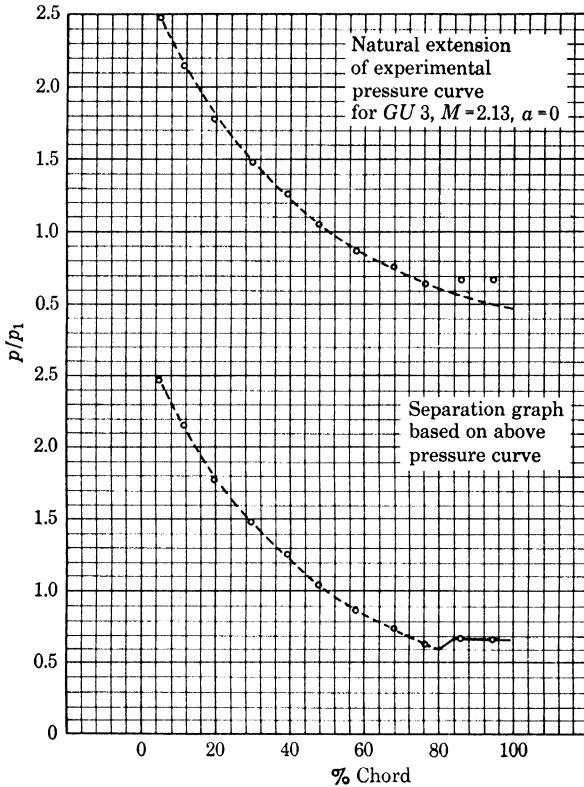

FIG. 6

number M , so that the tangent at the front vertex will make the same angle with the direction of the free stream in the case of each profile. Any difference in separation effects will then obviously be due to the influence of the tail ends of the profiles, and a comparison of the calculated and experimental pressures along these profiles will test specifically the validity of assumption 4.

The observed or stationary flow with separation in the case of the models tested may possibly originate from an unstable flow without separation in such a way that the influence of the tail vertex persists throughout transition to the stationary flow. It is conceivable that a modification of the boundary conditions, *e.g.*, use of profiles of widely different shape, may minimize or entirely

eliminate the influence of tail effects on the separation of the flow. If this supposition is borne out by experimental evidence, then the complete set of assumptions made in this article will presumably yield good quantitative results only for a class of profiles which do not differ too greatly in certain essential characteristics from the GU2 and GU3 profiles.

BIBLIOGRAPHY

1. A. Ferri, *Alcuni risultati sperimentali riguardanti profili alari provati alla galleria ultrasonora di Guidonia*, Atti Guidonia no. 17 (1939) pp. 337-372. Translated as NACA Tech. Mem. 946.
2. N. Edmonson, F. D. Murnaghan, and R. M. Snow, *The theory and practice of two dimensional supersonic pressure calculations*, The Johns Hopkins Univ. App. Phys. Lab., Bumblebee Rep. 26 (1945).
3. T. Y. Thomas, *The separation of supersonic flow from curved profiles*, Ind. Univ. Pub. Sci. Ser. 17 (1951).

GRADUATE INSTITUTE FOR APPLIED MATHEMATICS, INDIANA UNIVERSITY,
BLOOMINGTON, IND.

ON THE CONSTRUCTION OF HIGH-SPEED FLOWS

BY

G. F. CARRIER AND K. T. YEN

1. Introduction. Considerable effort has been expended in recent years on the construction of flow patterns in which sonic or nearly sonic speeds characterize a portion of the flow field [1]. In this paper, we shall present a new method of constructing such flows. The method is formally very simple and has the advantage that the flow is represented in closed form in the hodograph variables. The general properties of the flow so defined are readily investigated, but the actual computations which determine the precise geometry are usually as involved as those associated with the methods already available.

2. The construction of flows. The hodograph equation which defines the stream function associated with the irrotational isentropic flow of a perfect gas may be written [1] as

$$(1) \quad (T_1 \psi_\tau)_\tau + T_2 \psi_{\theta\theta} = 0.$$

Here τ is the square of the speed divided by the speed corresponding to zero density, θ is the velocity direction coordinate, ψ is the stream function,

$$(2) \quad T_1 = 2\tau(1 - \tau)^{-\beta},$$

$$(3) \quad T_2 = \frac{1 - (2\beta + 1)\tau}{2\tau(1 - \tau)^{\beta+1}}, \quad \beta = (\gamma - 1)^{-1},$$

where γ is the specific-heat ratio c_p/c_v .

It is desired, of course, that we obtain solutions of (1) which correspond to physical flows of interest. Some well-known solutions of this equation appear in the form

$$\psi = F(n, \tau) e^{in\theta},$$

where $F(n, \tau) = \tau^{n/2} F(a_n, b_n; n + 1; \tau)$ and $a_n + b_n = n - \beta$,

$$a_n b_n = \frac{-\beta n(n + 1)}{2}.$$

For convenience, we may write some similar product solutions in the form¹

$$\psi = \lim_{k \rightarrow 0} F(-i\xi, \tau) e^{-\theta \sqrt{\xi^2 + k^2}},$$

and, in particular, we shall use

$$(4) \quad \psi = \lim_{k \rightarrow 0} \int_{-\infty}^{\infty} F(-i\xi, \tau) e^{-\theta \sqrt{\xi^2 + k^2}} g(\xi) d\xi.$$

¹ The inclusion of the k is purely for convenience. It will not always be clear how to introduce k advantageously, but where it is clear, it has advantages which will appear in the forthcoming examples.

It is clear that, when this integral defines a sufficiently well-behaved function, that function will be a solution of (1).

In presenting this construction, it is convenient to cite a particular example of a flow defined as in (4). We first introduce a distorted speed ω , where, with $\tau_c = (2\beta + 1)^{-1}$,

$$\omega(\tau) = \sigma + \int_{\tau_c}^{\tau} \sqrt{1 - M^2} \frac{d\tau}{2\tau}.$$

The negative real constant σ is defined in [1] and is such that $\tau^{\frac{1}{2}}e^{-\omega} \rightarrow 1$ as $\tau \rightarrow 0$. M is the Mach number and is given by

$$M^2 = \frac{2\beta\tau}{1 - \tau}.$$

With these definitions we define a stream function

$$(5) \quad \psi_1 = \lim_{k \rightarrow 0} \int_{-\infty}^{\infty} \frac{e^{i\xi\omega_0} F(-i\xi, \tau) e^{-\theta\sqrt{\xi^2+k^2}}}{(\xi + ik)^{\frac{1}{2}}} d\xi.$$

Here, ω_0 is a (real, negative) value of ω corresponding to a given subsonic τ . We first note that the integral converges² for $\theta \geq 0$, and, in particular, when

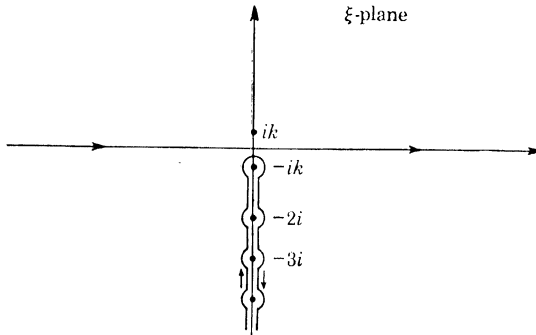

FIG. 1. The horizontal contour is the integration path for subsonic τ ; the indented contour is that for supersonic τ . The points $-mi$ are those at which $F(-i\xi, \tau)$ has simple poles.

$\omega < \omega_0$ and $\theta = 0$, $\psi_1(\tau, 0) = 0$. This is a consequence of the asymptotic behavior of $F(-i\xi, \tau)$. As shown in [1], F behaves asymptotically with regard to $-i\xi$ according to the rule

$$(6) \quad F(-i\xi, \tau) \sim V(\tau)e^{-i\xi\omega},$$

where $V(\tau) = (1 - \tau)^{(2\beta+1)/4} / [1 - (2\beta + 1)\tau]^{\frac{1}{2}}$, provided $|\arg \xi + \pi/2| < \pi - \delta$.

It is also a consequence of this asymptotic behavior that ψ_1 has a branch point of order $\frac{1}{2}$ at $\omega = \omega_0$, $\theta = 0$. We mean by this that $\psi_1 \sim \text{Im}(\omega - \omega_0 + i\theta)^{\frac{1}{2}}$ near $(\omega_0, 0)$.

We note further that the integral (4) will converge for all subsonic τ , that

² The corresponding (and alternative) solution with $e^{+\theta\sqrt{\xi^2+k^2}}$ converges only for $\theta < 0$.

the contour may be deformed³ as indicated in Fig. 1 for $\sigma > \omega > \omega_0$ and still yield the same function $\psi_1(\tau, \theta)$, and finally that (4) converges and defines a "well-behaved" function for supersonic τ along this distorted contour. It is thus clear that the analytic continuation of (4) for supersonic τ is associated with the same integrand but a new contour.

The evaluation of ψ_1 for subsonic τ is very straightforward. We merely use the subsonic partial-fraction expansion [1] of $F(-i\xi, \tau)$ and integrate term by term. To establish the convergence of the series so formed is a simple routine, and in fact the series takes the form

$$(7) \quad \psi_1 = \zeta^{\frac{1}{2}} - \bar{\zeta}^{\frac{1}{2}} - \frac{\pi^{\frac{1}{2}}}{2} \sum_{m=2}^{\infty} m^{-\frac{1}{2}} C_m \psi_m(\tau) e^{m\omega} [e^{m\zeta} (1 - \operatorname{erf} m^{\frac{1}{2}} \zeta^{\frac{1}{2}}) - e^{m\bar{\zeta}} (1 - \operatorname{erf} m^{\frac{1}{2}} \bar{\zeta}^{\frac{1}{2}})],$$

where $\zeta = \omega_0 - \omega + i\theta$ and $\bar{\zeta}$ is its complex conjugate.

It is clear that this series is meaningful for both positive and negative θ , despite the fact that the integral was defined for positive θ . Near the sonic line, however, it is not a very convenient representation. The individual terms are expressed in terms of ω , which, in turn, behaves like $(\tau - \tau_c)^{\frac{1}{2}}$ when $\tau - \tau_c \ll 1$. Since an inspection of (4) and a knowledge of the properties of F indicate that ψ_1 is defined and differentiable near and on $\tau = \tau_c$, a series on $(\tau - \tau_c)^{\frac{1}{2}}$ is not very convenient. In the supersonic domain, a partial-fraction expansion of F is again permitted, and the integration could again be carried out term by term. This time, however, the coefficient functions of τ will be made up of terms as in (7) and also of hypergeometric functions where τ appears in both arguments. This would lead to extremely cumbersome calculations and is worth while only if one is interested in the detailed flow. Thus, in this particular problem it is relatively easy [using (7)] to construct in detail a DeLaval nozzle with a subsonic flow and to represent, but not calculate in detail, an accelerated-decelerated transonic DeLaval nozzle flow. Alternatively shaped nozzles can easily be obtained by adding to ψ_1 functions of the type $F(m, \theta) \sin m\theta$ which do not change the character of the branch point in ω at ω_0 .

Figure 2 indicates the streamlines of this flow in a $\{\ln [\tau(2\beta + 1)], \theta\}$ -plane. One can see that ω_0 corresponds to the maximum speed attained on the axis of symmetry of the channel.

A second flow can readily be computed by defining

$$(8) \quad \psi_2 = \lim_{k \rightarrow 0} \int_{-\infty}^{\infty} \frac{e^{i\xi\omega_0} f'(-i\xi, \tau) e^{-\theta\sqrt{\xi^2 + k^2}}}{(\xi + ik)^{\frac{1}{2}}} d\xi.$$

Again, essentially the same discussion applies except the remarks concerning the geometry and the order of the branch point. In this regard, the branch

³ It is with regard to this contour deformation that it is convenient to include the parameter k , which later shrinks to zero.

point is of order $(-\frac{1}{2})$, and a linear combination of ψ_1 and ψ_2 will lead to the flow depicted in Fig. 3. This represents half the flow past a cuspidal body which is symmetric about an axis in the flow direction but not symmetric fore and aft, as shown in Fig. 4. To obtain the double symmetry, one must also use those functions analogous to ψ_1 and ψ_2 containing $+\theta$ in the integrand.

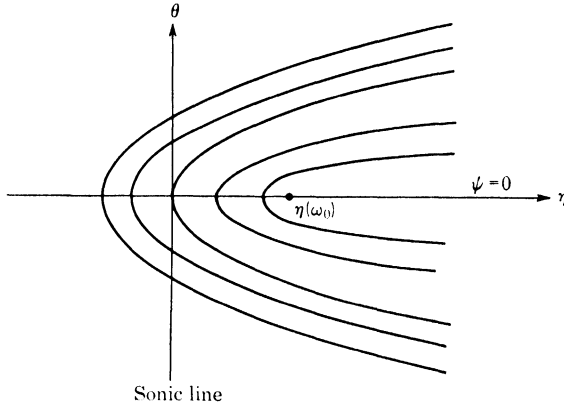

FIG. 2. Contours of $\psi_1 = \text{constant}$. $\eta = -\ln [\tau(2\beta + 1)]$.

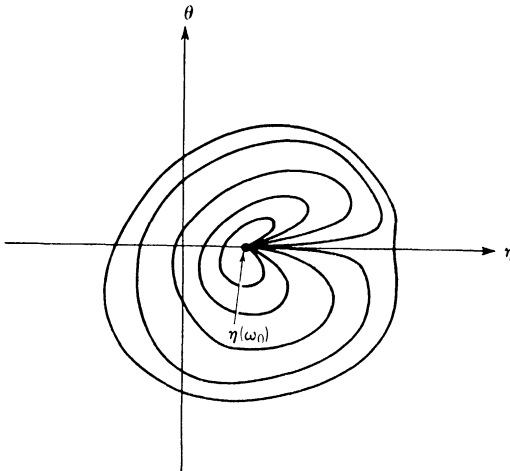

FIG. 3. $\psi_1 + A\psi_2$ streamlines. $\eta = -\ln [\tau(2\beta + 1)]$.

ψ_2 can also be evaluated by use of the partial-fraction expansion of F . In fact, ψ_2 is given for subsonic τ by

$$(9) \quad \psi_2 = \zeta^{-\frac{1}{2}} - \bar{\zeta}^{-\frac{1}{2}} + \sum_{m=2}^{\infty} C_m \psi_m(\tau) e^{m\omega} \{ \zeta^{-\frac{1}{2}} - \bar{\zeta}^{-\frac{1}{2}} - m^{\frac{1}{2}} \pi^{\frac{1}{2}} [e^{m\zeta} (1 - \text{erf } m^{\frac{1}{2}} \zeta^{\frac{1}{2}}) - e^{m\bar{\zeta}} (1 - \text{erf } m^{\frac{1}{2}} \bar{\zeta}^{\frac{1}{2}})] \}.$$

It is now convenient to note that the foregoing construction is really quite analogous to that of Chaplygin. We are essentially taking the Fourier trans-

form in the hodograph plane of the stream function of an incompressible flow and inverting that transform, not with an exponential function but with a hypergeometric function. In fact, the construction was discovered while attempting to find a transform pair of hypergeometric type such that the equation (1) could be treated formally by transform techniques. In particular, the foregoing problems were to be treated by the Wiener-Hopf type of analysis. It also becomes evident that the functions $(\xi + ik)^{-\nu/2} e^{i\xi\omega_0}$ occurring in (5) and (8) are the transforms of the jump in ψ_θ across the line $\theta = 0$, $\omega < \omega_0$ in an (ω, θ) -plane and are also the transforms of the jumps in ψ_θ in a $(\ln q, \theta)$ incompressible plane. Our method of construction, then, is to consider an incompressible flow, compute the exponential transform in $\ln q$ of the jump in ψ_θ on $\theta = 0$, and to put it into the formula of the type (5). One must then ascertain whether the desired properties of the flow are maintained. If they are, a computation can be initiated.

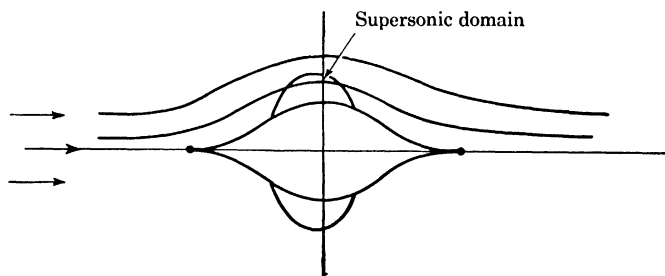

FIG. 4. The upper half of this flow field corresponds to the "hodograph" depicted in Fig. 3.

We are now investigating flows with stagnation points by this technique but are not yet at a stage where a detailed report can be made. In particular, however, in the consideration of a flow with a stagnation point, we have found one stream function as in (4) which, upon successive integrations by parts, reduces precisely to Lighthill's series [2]. Thus, we have a representation of his solution which is formally in closed form. A more detailed account of the flows which can be investigated by this method should be available in the near future.

A final remark which associates the foregoing results with some previous work seems appropriate. If we considered (as many authors have) a hypothetical gas whose equation of state leads to the Tricomi equation as that governing the stream-function behavior, then the solutions corresponding to the flows derived here are available in very concise form [3]. They have also been found in a different manner [4] by essentially the method described above. The result in [4] appears in a more general form than the Tricomi solutions but is easily identified when the appropriate special case is considered.

BIBLIOGRAPHY

1. F. E. Ehlers, *Methods of linearization in compressible flow*, II, *Hodograph method*, Wright Field Tech. rep. F-TR-1180B-ND (February, 1948). This paper contains a reasonably complete bibliography.

2. M. J. Lighthill, *The hodograph transformation in transonic flow*, II, Proc. Roy. Soc. London Ser. A vol. 191 (1947).
3. S. Tomotika and K. Tomada, *Studies on two-dimensional transonic flows of a compressible fluid*, II, Quart. Appl. Math. vol. 8 (July, 1950) pp. 127-136.
4. G. F. Carrier, *A generalization of the Wiener-Hopf technique*, Quart. Appl. Math. (April, 1949).

BROWN UNIVERSITY,
PROVIDENCE, R.I.

AN EXAMPLE OF TRANSONIC FLOW FOR THE TRICOMI GAS¹

BY

M. H. MARTIN AND W. R. THICKSTUN

1. Introduction. Tricomi's [1] equation $\psi_{\sigma\sigma} + \sigma\psi_{\theta\theta} = 0$ has been proposed by various authors [2] as a first approximation to the equation

$$\psi_{\sigma\sigma} + K(\sigma)\psi_{\theta\theta} = 0$$

arising [3] in the study of transonic flow of a polytropic gas.

In this note we study the equation of state for a compressible fluid whose flow is governed by Tricomi's equation, obtaining, among other results, the theorem in Sec. 3, first obtained, by another method, by S. C. Wang.²

The particular solution to Tricomi's equation defined by $\psi^3 + 3\sigma\psi = 3\theta$, previously given by Tomotika and Tomada³ and others, is obtained by another method, and a detailed analysis of the flow in the physical plane is carried out by studying the mapping from the (σ, ψ) -plane to the physical plane. This mapping is single-valued and for this reason is easier to handle than the conventional mapping of the hodograph plane upon the physical plane, which may be one-to-three (or one-to-two) in the supersonic region.

The flow is drawn in Fig. 5b. Perhaps its most striking feature is a sonic line not unlike a Cornu spiral.

2. Fundamental principles. A general flow is presented [4] in the physical plane by

$$(1) \quad \begin{aligned} x &= \int \left\{ -\frac{q_{pp} - q\theta_p^2}{\theta_\psi} \cos \theta dp + (q \sin \theta)_p d\psi \right\}, \\ y &= \int \left\{ -\frac{q_{pp} - q\theta_p^2}{\theta_\psi} \sin \theta dp - (q \cos \theta)_p d\psi \right\}, \end{aligned}$$

and in the hodograph plane by

$$(2) \quad u = q \cos \theta, \quad v = q \sin \theta,$$

where the Bernoulli function $q = q(p, \psi)$ and the direction function $\theta = \theta(p, \psi)$ are any two functions which jointly satisfy

$$(3) \quad q \left(\frac{q_{pp} - q\theta_p^2}{\theta_\psi} \right)_\psi + (q^2\theta_p)_p = 0.$$

¹ Supported by the Office of Naval Research.

² Presented Jan. 31, 1950, in the Seminar of the Institute for Fluid Dynamics and Applied Mathematics at the University of Maryland, College Park, Md.

³ In their treatment [2] a one-parameter family of solutions (including the particular solution treated in the present paper) is discussed from the standpoint of the change in character of the flow as the parameter is varied. This solution has also been treated by Cherry in his address before the International Conference on Theoretical Fluid Mechanics Aug. 28, 1950, at Harvard University, Cambridge, Mass.

With the introduction of the complex variables

$$(4) \quad z = x + iy, \quad h = u + iv,$$

equations (1) and (2) are abbreviated to

$$(5) \quad z = \int e^{i\theta} \left\{ -\frac{q_{pp} - q\theta_p^2}{\theta_\psi} dp + (q\theta_p - iq_p) d\psi \right\}, \quad h = qe^{i\theta}.$$

The vorticity ω , density ρ , and Mach number M are given by

$$(6) \quad \omega = -\frac{q_\psi}{q_p}, \quad \rho = -(qq_p)^{-1}, \quad M^2 = 1 + \frac{qq_{pp}}{q_p^2},$$

from which it is seen that the flow is subsonic, sonic, or supersonic according as $q_{pp} \gtrless 0$ and that the flow is irrotational if, and only if, $q = q(p)$, where $q(p)$ is a decreasing function of p . The acoustic speed q_* is accordingly calculated as $q_* = q(p_*)$, where p_* , the acoustic pressure, is defined by $q_{pp}(p_*) = 0$.

For irrotational flows, in place of the pressure p , we introduce a new variable σ defined by

$$(7) \quad \sigma = \int_{p_*}^p q^{-2} dp = \sigma(p).$$

This is the same variable σ used by Frankl [3] and others in the study of transonic flows, for on introducing q for integration variable in (7), the equation reduces to

$$\sigma = \int_q^{q_*} \frac{\rho}{q} dq.$$

It is clear that, according as $\sigma \gtrless 0$, the flow is subsonic, sonic, or supersonic.

In addition we set

$$(8) \quad K(\sigma) = -q^3 q_{pp},$$

the second member, originally a function of p , becoming a function of σ with the aid of (7). As we shall see in a moment, this is the function $K(\sigma)$ employed by Frankl.

Indeed, when σ replaces p as independent variable in (3), this equation becomes

$$(9) \quad \theta_{\sigma\sigma} = \left[\frac{K(\sigma) + \theta_\sigma^2}{\theta_\psi} \right]_\psi.$$

A solution $\theta = \theta(\sigma, \psi)$ of this equation defines ψ implicitly as a function of θ, σ , and a routine calculation verifies that $\psi = \psi(\theta, \sigma)$ is a solution of

$$(10) \quad \psi_{\sigma\sigma} + K(\sigma)\psi_{\theta\theta} = 0,$$

the partial differential equation employed by Frankl [3].

The introduction of σ in place of p into (5) yields

$$(11) \quad z = \int \kappa e^{i\theta} \left\{ \frac{K + \theta_\sigma^2}{\theta_\psi} d\sigma + \left(\theta_\sigma + i \frac{\kappa_\sigma}{\kappa} \right) d\psi \right\}, \quad h = \frac{e^{i\theta}}{\kappa},$$

provided we set

$$(12) \quad \kappa = \kappa(\sigma) = \frac{1}{q}$$

In view of (7) and (12) one has $q^3 q_{pp} = -\kappa_{\sigma\sigma}/\kappa$, and (8) yields

$$(13) \quad \kappa_{\sigma\sigma} - K(\sigma)\kappa = 0.$$

Let $\kappa = \kappa(\sigma)$ be any solution of (13) for a given function $K(\sigma)$. From (12), (6), and (7) we can express the speed, density, and pressure as functions

$$(14) \quad q = \frac{1}{\kappa} = q(\sigma), \quad \rho = \frac{\kappa}{\kappa_\sigma} = \rho(\sigma), \quad p = C + \int_0^\sigma \kappa^{-2} d\sigma = p(\sigma),$$

of the parameter σ . The last two equations lead to the equation of state of the gas, for when σ is eliminated from them, one has a pressure-density relation $p = p(\rho)$.

Once $K(\sigma)$ is specified, and a solution $\kappa(\sigma)$ of (13) is selected, any solution $\theta = \theta(\sigma, \psi)$ of (9), when inserted in (11), yields parametric representations for the flows in the physical and hodograph planes.

The Jacobian J of the transformation (11) from the (σ, ψ) -plane to the physical plane is

$$J = \kappa \kappa_\sigma \theta_\psi^{-1} (K + \theta_\sigma^2).$$

The determination of solutions to (9) is accordingly the decisive step. The integration of (9) may be replaced by the integration of another partial differential equation as follows: If $\theta = \theta(\sigma, \psi)$ is a solution of (9), there exists a function $\varphi = \varphi(\sigma, \psi)$ such that

$$\varphi_\psi = \theta_\sigma, \quad \varphi_\sigma = \frac{K + \theta_\sigma^2}{\theta_\psi}; \quad \text{or} \quad \theta_\sigma = \varphi_\psi, \quad \theta_\psi = \frac{K + \varphi_\psi^2}{\varphi_\sigma},$$

and when θ is eliminated by partial differentiation from the second pair, we see that φ is a solution of

$$(15) \quad \varphi_{\psi\psi} = \left(\frac{K + \varphi_\psi^2}{\varphi_\sigma} \right)_\sigma.$$

Conversely, if $\varphi = \varphi(\sigma, \psi)$ is a solution to (15), a solution of (9) is

$$(16) \quad \theta = \int \left\{ \varphi_\psi d\sigma + \frac{K + \varphi_\psi^2}{\varphi_\sigma} d\psi \right\}.$$

The integration of (9) is accordingly equivalent to the integration of (15), the two partial differential equations being related to each other by a Bäcklund transformation [5].

3. The Tricomi gas. For a polytropic gas

$$(17) \quad \rho = k p^n, \quad q^2 = \hat{q}^2 - \frac{2p^{1-n}}{k(1-n)}, \quad \left(0 < n = \frac{1}{\gamma} < 1 \right),$$

where k and \hat{q} denote constants for irrotational flow, \hat{q} being the maximum speed of flow. The acoustic pressure p_* as defined above turns out to be

$$(18) \quad p_* = \left(kn \frac{1-n}{1+n} \hat{q}^2 \right)^{1/(1-n)},$$

from which the acoustic speed q_* and acoustic density ρ_* are found to be

$$(19) \quad q_* = \sqrt{\frac{1-n}{1+n}} \hat{q}, \quad \rho_* = k \left(kn \frac{1-n}{1+n} \hat{q}^2 \right)^{n/(1-n)}.$$

The essential point of the above formulas is that they show, once the constants k , \hat{q} , γ are fixed, that the acoustic values of the pressure, speed, and density are completely determined.

One can expand $K(\sigma)$ in a power series about $\sigma = 0$,

$$(20) \quad K(\sigma) = a\sigma + b\sigma^2 + \dots,$$

there being no constant term in view of (7) and (8). To compute the constant a , one observes that

$$a = K_\sigma \Big|_0 = \frac{K_p}{\sigma_p} \Big|_{p_*}.$$

From (7) and (8) we find

$$a = -q^5 q_{ppp} \Big|_{p_*}.$$

Thus a may be calculated by differentiating the second formula in (17) three times and evaluating for $p = p_*$. One finds in this way that

$$a = \frac{\gamma + 1}{\rho_*^3}.$$

It is obvious that by suitable choice of units we can always realize

$$(21) \quad \rho_*^3 = \gamma + 1,$$

to make $a = 1$. With this normalization (20) is replaced by

$$(22) \quad K(\sigma) = \sigma + b\sigma^2 + \dots$$

As a first approximation to (22) it is usual to take $K(\sigma) = \sigma$, whereupon (10) and (13) become

$$(23) \quad \psi_{\sigma\sigma} + \sigma\psi_{\theta\theta} = 0, \quad \kappa_{\sigma\sigma} - \sigma\kappa = 0.$$

The first equation is Tricomi's equation, and the general solution of the second is

$$(24) \quad \kappa = A\sigma^{\frac{1}{2}} I_{\frac{1}{2}}\left(\frac{2}{3}\sigma^{\frac{3}{2}}\right) + B\sigma^{\frac{1}{2}} I_{-\frac{1}{2}}\left(\frac{2}{3}\sigma^{\frac{3}{2}}\right),$$

where A and B are arbitrary constants and $I_{\frac{1}{2}}$ and $I_{-\frac{1}{2}}$ are the modified Bessel functions defined by

$$(25) \quad I_n(z) = \sum_{k=0}^{\infty} \frac{1}{k! \Gamma(k+n+1)} \left(\frac{z}{2}\right)^{2k+n}.$$

In place of (9) we have

$$(26) \quad \theta_{\sigma\sigma} = \left(\frac{\sigma + \theta_\sigma^2}{\theta_\psi} \right)_\psi.$$

Any solution $\theta(\sigma, \psi)$ of this equation, when substituted in (11), together with κ as defined by (24), yields a flow in the physical plane in which the streamlines are the transforms by (11) of the straight lines $\psi = \text{constant}$ in the (σ, ψ) -plane. The straight lines $\sigma = \text{constant}$ of the (σ, ψ) -plane are carried into curves (isovels, isopycnics, isobars) in the physical plane, along each of which q, ρ, p have constant values assigned by (14). In particular the straight line $\sigma = 0$ is carried over into the sonic line in the physical plane.

By a *Tricomi gas* we mean a fluid whose equation of state $\rho = \rho(p)$ results when σ is eliminated between the latter two equations in (14) for κ as defined in (24). By suitably adjusting the arbitrary constants A, B in (24) and the arbitrary constant C in (14), one can realize

$$(27) \quad q(0) = q_*, \quad \rho(0) = \rho_*, \quad p(0) = p_*,$$

where q_*, ρ_*, p_* are the acoustic speed, density, and pressure for a polytropic gas as defined in (18) and (19). With this choice of A, B, C , the speed, density, and pressure of the Tricomi gas along the sonic line in the physical plane will be in agreement with the acoustic values of these quantities for a polytropic gas.⁴ Moreover, from (14) and (23)

$$(28) \quad p_\sigma = \frac{1}{\kappa^2} = q^2, \quad \rho_\sigma = 1 - \sigma\rho^2; \quad p_{\sigma\sigma} = -\frac{2q^2}{\rho},$$

$$\rho_{\sigma\sigma} = -\rho^2 - 2\sigma\rho(1 - \sigma\rho^2).$$

For $\sigma = 0$ these reduce to

$$(29) \quad p_\sigma = q_*^2, \quad \rho_\sigma = 1; \quad p_{\sigma\sigma} = -\frac{2q_*^2}{\rho_*}, \quad \rho_{\sigma\sigma} = -\rho_*^2,$$

and therefore

$$p_\rho = q_*^2, \quad p_{\rho\rho} = \frac{q_*^2}{\rho_*} (\rho_*^3 - 2) = \frac{q_*^2}{\rho_*} (\gamma - 1)$$

the last result being a consequence of (21). Since the same relations hold for a polytropic gas at acoustic conditions, the following theorem has been established:

THEOREM. *When the speed q , density ρ , and pressure p of a Tricomi gas on the sonic line are brought into agreement with the acoustic values q_*, ρ_*, p_* of these quantities for a polytropic gas, the graphs of the two equations of state in the (ρ, p) -plane have contact of at least the second order at the point (ρ_*, p_*) .*

We shall now show that the graph of the equation of state for a Tricomi gas under the conditions of the above theorem has the form shown in Fig. 1.

First of all, the graph of the solution $\kappa = \kappa(\sigma)$ of the second equation in (23), subject to the initial conditions

⁴ For an alternative adjustment of the constants see [6, p. 282].

$$\kappa(0) = \frac{1}{q_*}, \quad \kappa_\sigma(0) = \frac{1}{\rho_* q_*}$$

prescribed by (14) and (27), must have the form shown in Fig. 2. Indeed, it is clear from the differential equation satisfied by $\kappa(\sigma)$ that for $\kappa > 0$, the graph is concave upward for $\sigma > 0$ and concave downward for $\sigma < 0$. Consequently, the graph lies above the initial tangent line for $\sigma > 0$ and below it for $\sigma < 0$, intersecting the σ -axis at an acute angle at a point $(\bar{\sigma}, 0)$. Thus as σ ranges from $\bar{\sigma}$ to $+\infty$, the speed q drops monotonely from $+\infty$ to 0.

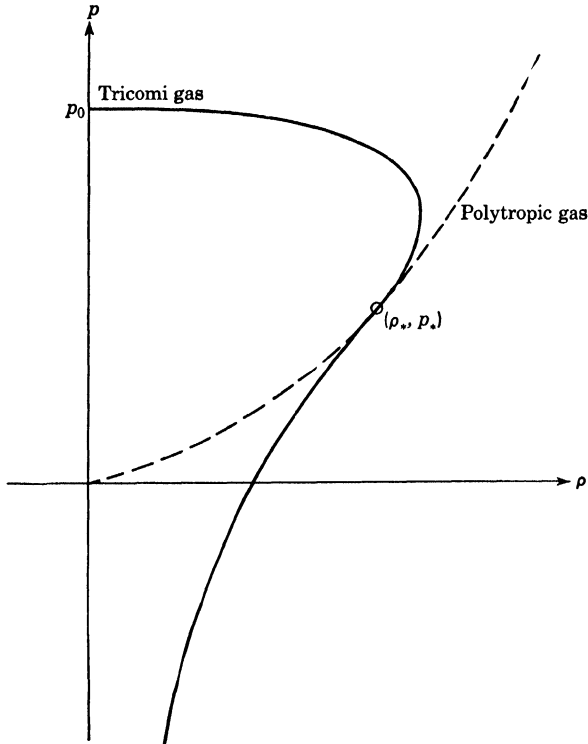

FIG. 1

From (14) and (27) the pressure is given by

$$(30) \quad p = p_* + \int_0^\sigma \kappa^{-2} d\sigma.$$

Obviously p is an increasing function of σ . As σ tends to $+\infty$, the pressure p tends to a finite limit p_0 (stagnation pressure), because

$$\kappa(\sigma) > \kappa(0) + \sigma\kappa_\sigma(0), \quad (\sigma > 0).$$

On the other hand, p tends to $-\infty$ as σ tends to $\bar{\sigma}$, for the expansion

$$\kappa(\sigma) = a(\sigma - \bar{\sigma}) + \dots, \quad (a \neq 0),$$

is valid about $\sigma = \bar{\sigma}$, since the graph of $\kappa = \kappa(\sigma)$ cuts the σ -axis at $(\bar{\sigma}, 0)$ at an angle different from zero.

From (28) we see that $\rho(\sigma)$ is a solution of the Ricatti differential equation

$$\rho_\sigma = 1 - \sigma\rho^2.$$

In the upper half of the (σ, ρ) -plane, $\rho(\sigma)$ is an increasing function of σ below the curve $\rho^2\sigma = 1$ and a decreasing function above it. For the particular solution for which $\rho(0) = \rho_*$, it is seen from (14) that $\rho(\bar{\sigma}) = 0$. Thus $\rho(\sigma)$ increases with σ up to a maximum value on $\rho^2\sigma = 1$ for some value of σ , say $\hat{\sigma}$, and thereafter decreases as shown in Fig. 3, since $\rho > \sigma^{-\frac{1}{2}}$ for $\sigma > \hat{\sigma}$. If this

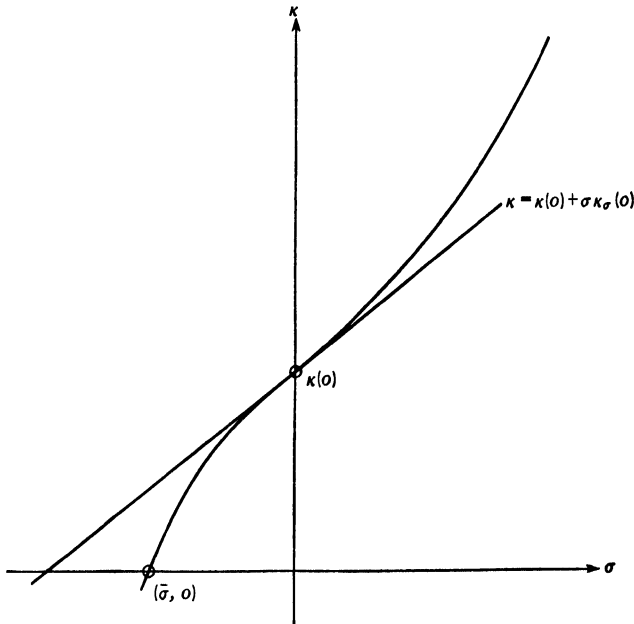

FIG. 2

were not true, there would be a first value, say $\sigma' > \hat{\sigma}$, for which $\rho = (\sigma')^{-\frac{1}{2}}$; but at such a point $\rho_\sigma(\sigma') = 0$. Hence $\rho \leq \sigma^{-\frac{1}{2}}$ in the neighborhood to the left of σ' , contradicting the assumption that σ' is the first value after $\hat{\sigma}$ for which $\rho = \sigma^{-\frac{1}{2}}$. Thus $\rho(\sigma) > 0$, and monotonely decreasing for $\sigma > \hat{\sigma}$, must approach a limit, say $\rho_0 \geq 0$, as σ tends to infinity. This limit, moreover, must be zero, since $\rho \geq \rho_0$ implies that $\rho_\sigma \leq 1 - \sigma\rho_0^2$, and hence that $\rho_\sigma \rightarrow -\infty$ for $\rho_0 > 0$, so that ρ eventually would become negative, contrary to our previous statement.

It is now clear from the nature of the functions $p(\sigma)$ and $\rho(\sigma)$ that the graph of $p = p(\rho)$ is as shown.

4. The direction function $\theta(\sigma, \psi)$. If one takes $K = \sigma$ in (15), it is readily verified that $\varphi = \sigma + \psi^2/2$ is a solution.⁵ With (16) this leads to the solution

⁵ This solution was discovered by searching for solutions to (15) of the form

$$\varphi = \Sigma(\sigma) + \Psi(\psi).$$

of (26),

$$(31) \quad \theta = \sigma\psi + \frac{\psi^3}{3},$$

as may be verified by direct substitution in (26) or in Tricomi's equation (23). Thus (31) yields a solution ψ of Tricomi's equation which is an algebraic function of σ, θ .

The method here may be extended to find other solutions of this type of Tricomi's equation or of the general equation (10), and initial steps have

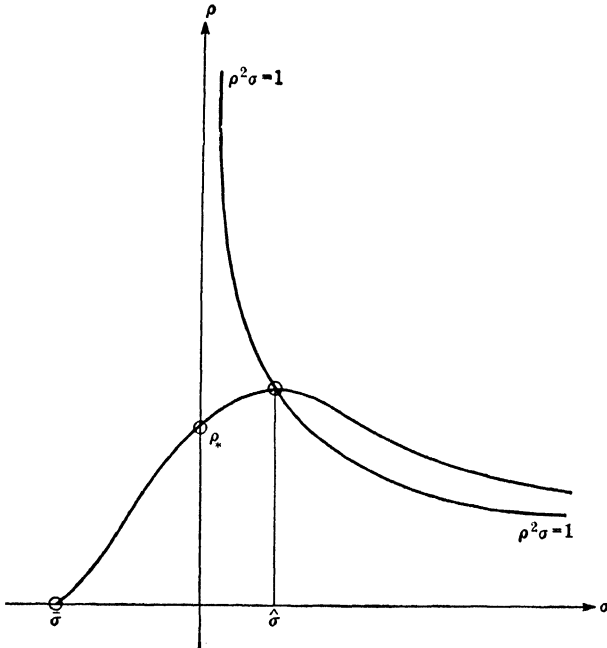

FIG. 3

been taken in this direction by J. Tierney [9]. In this paper we shall, however, confine ourselves to the solution given above as the simplest example of its kind.

5. The flow in the hodograph plane. The streamlines in the hodograph plane $[(\theta, \sigma)\text{-plane}]$ are obtained by setting $\psi = \text{constant}$ in (31). They constitute a one-parameter family of straight lines tangent to the characteristic $\theta^2 = -\frac{4}{3}\sigma^3$ of Tricomi's equation shown in Fig. 4. Through a point P_1 above the characteristic, only one streamline passes; two streamlines pass through a point P_2 on the characteristic; below the characteristic, three streamlines pass through a point P_3 . Each point in the hodograph plane below the characteristic maps into three points in the physical plane, while those above it map into single points in the physical plane. The points on the characteristic map into two points in the physical plane, and the loci of these points in the physical plane constitute the line of branch points [7].

The behavior of the flow in the hodograph plane in the neighborhood of the sonic line suggests the flow in the hodograph plane in the neighborhood of the sonic line for a Laval nozzle.

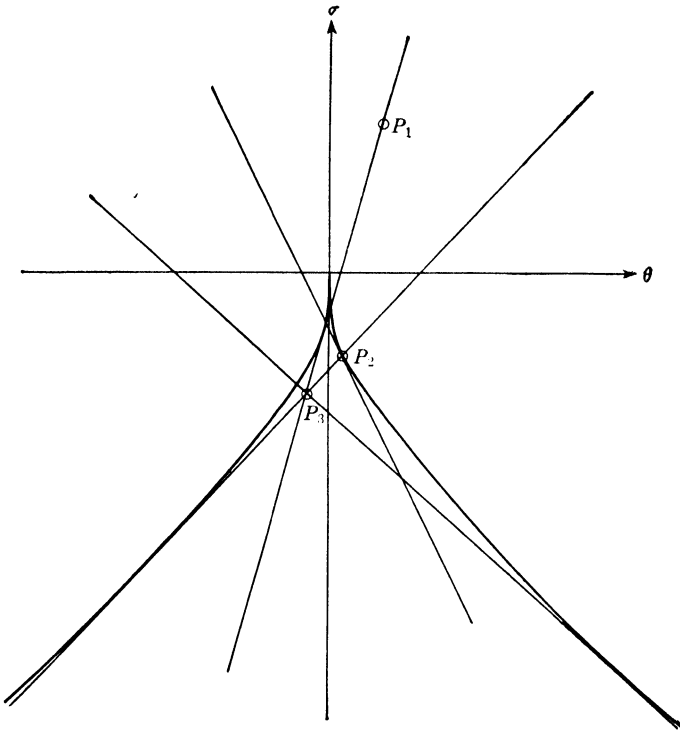

FIG. 4

6. The flow in the physical plane. If we place $K(\sigma) = \sigma$ and substitute from (31) for θ in (11), the mapping from the (σ, ψ) -plane to the physical plane is

$$(32) \quad z = \int \kappa e^{i\theta} \left\{ d\sigma + \left(\psi + i \frac{\kappa\sigma}{\kappa} \right) d\psi \right\}, \quad \theta = \sigma\psi + \frac{\psi^3}{3},$$

where $\kappa = \kappa(\sigma)$ is defined in (24) with arbitrary constants A and B fixed by the conditions (27).

To obtain a streamline in the physical plane, the line integral in (32) may be evaluated along either of the paths OAP and OBP in Fig. 5a, with A fixed and B variable; to draw an isovel, either path may be used again, but now B is fixed and A is variable.

For $\psi = 0$, point A coincides with O , and the streamline in the physical plane is the x -axis with

$$(33) \quad x = \int_0^\sigma \kappa d\sigma = x(\sigma), \quad \bar{x} = x(\bar{\sigma}).$$

This, in conjunction with (14), gives the speed, density, and pressure for $x > \bar{x}$. As x ranges from \bar{x} to $+\infty$, the speed q decreases monotonely from $+\infty$ to zero and the pressure p increases monotonely from $-\infty$ to the stagnation pressure p_0 .

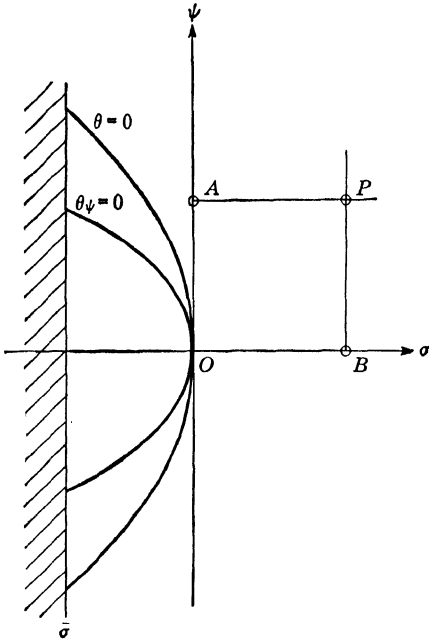

FIG. 5a

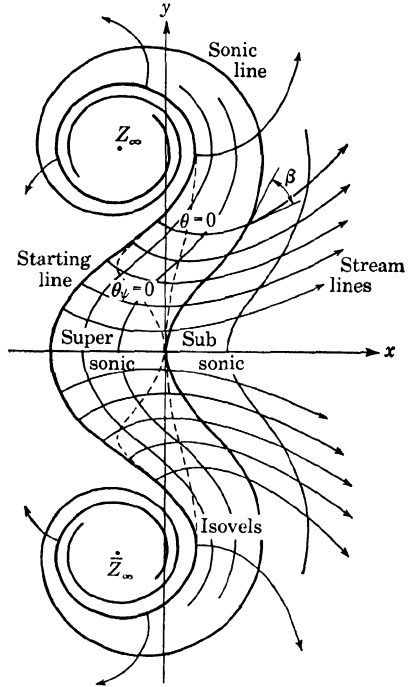

FIG. 5b

For $\sigma = 0$, point B coincides with O , and the isovel in the physical plane is the sonic line with

$$(34) \quad z = \frac{1}{q_*} \int_0^\psi e^{i\psi^{2/3}} (\psi + i\rho_*^{-1}) d\psi.$$

If one places $\psi^3 = 3t$, this reduces to

$$z = \frac{1}{3^{1/2}q_*} \int_0^t s^{-1/2} e^{is} ds + \frac{i}{3^{1/2}\rho_*q_*} \int_0^t s^{-1/2} e^{is} ds,$$

and since [8]

$$\int_0^\infty s^{-n} e^{is} ds = \frac{\pi}{2\Gamma(n) \cos(\pi/2)n} + \frac{i\pi}{2\Gamma(n) \sin(\pi/2)n}, \quad (0 < n < 1),$$

it follows that, as t increases indefinitely, a point z on the sonic line must approach

$$z_\infty = \frac{1}{2 \cdot 3^{1/2}q_*} \left(\Gamma\left(\frac{2}{3}\right) - \frac{\Gamma\left(\frac{1}{3}\right)}{[3(\gamma + 1)]^{1/2}} \right) + i \frac{3^{1/2}}{2q_*} \left(\Gamma\left(\frac{2}{3}\right) + \frac{\Gamma\left(\frac{1}{3}\right)}{[3(\gamma + 1)]^{1/2}} \right),$$

where we have used (21), to eliminate ρ_* , and the well-known formula

$$\Gamma\left(\frac{1}{3}\right)\Gamma\left(\frac{2}{3}\right) = \frac{2\pi}{\sqrt{3}}$$

For $q_* = 1$, $\gamma = 1.4$, a numerical calculation shows

$$z_\infty = -0.3635 + 1.2943i,$$

and as Fig. 5*b* indicates, the sonic line spirals into this point. The spiral character of the sonic line is obvious at once from

$$\arg z_\psi = \frac{\psi^3}{3} + \arg(\psi + i\rho_*^{-1}),$$

on letting ψ increase indefinitely.

From (34) it is obvious that

$$z_\psi = \frac{i}{q_*\rho_*}, \quad z_{\psi\psi} = \frac{1}{q_*}, \quad (\text{for } \psi = 0).$$

Consequently the sonic line meets the x -axis at right angles and, at this point, turns its concave side toward the subsonic region.

It is a remarkable fact that not only the sonic line but every isovel spirals into z_∞ . This is an immediate consequence of the formula

$$z = z_* + \int_0^\sigma \kappa e^{i\theta} d\sigma.$$

Here z_* is the point on the sonic line corresponding to A in Fig. 5*a*, and the formula itself arises by evaluating the line integral (32) along the path OAP . On substituting for θ , one has

$$(35) \quad z = z_* + e^{i\psi^3/3} \int_0^\sigma \kappa e^{i\sigma\psi} d\sigma.$$

If we set $\sigma = \sigma_1 = \text{constant}$ and let ψ increase, z traces out an isovel, and

$$\lim_{\psi \rightarrow \infty} \int_0^{\sigma_1} \kappa e^{i\sigma\psi} d\sigma = 0,$$

by Riemann's lemma. Thus every isovel has z_∞ for limit point. That each isovel actually spirals about z_∞ infinitely many times is clear from the expression

$$\arg z_\psi = \theta + \arg\left(\psi + i\frac{\kappa_\sigma}{\kappa}\right),$$

since the second term of the right member (call it β) is seen to be equivalent to

$$(36) \quad \beta = \text{arccot } \rho\psi,$$

which is certainly bounded. Thus $\arg z_\psi$ increases indefinitely with θ as ψ becomes infinite.

If, however, we put $\psi = \psi_1 = \text{constant}$ in (35) and let σ increase, z traces out the streamline through the point z_* on the sonic line with

$$z = z_*(\psi_1) + e^{i\psi_1/3} \int_0^\sigma \kappa e^{i\sigma\psi_1} d\sigma.$$

Since $\lim_{\sigma \rightarrow \infty} \kappa(\sigma) = +\infty$ and furthermore since $\kappa'(\sigma) > \kappa'(0) > 0$ for $\sigma > 0$, it follows from results of Jackson [10] that the streamlines defined by the above formula must spiral to infinity as $\sigma \rightarrow +\infty$.

The parabolas

$$3\sigma + \psi^2 = 0, \quad \theta_\psi = \sigma + \psi^2 = 0,$$

in the (σ, ψ) -plane become the isocline $\theta = 0$ and the line of branch points $\theta_\psi = 0$ shown in Fig. 5b.

The angle β measured positively counterclockwise from the direction of flow on a streamline to the tangent line of the isobar through a point P of the physical plane is given⁶ by

$$\cot \beta = -\frac{q\theta_P}{q_P}.$$

For the particular solution under consideration, this reduces to

$$\cot \beta = \rho\psi,$$

which is indeed the same as β defined in (36). If we recall that $q(\bar{\sigma}) = +\infty$, $\rho(\bar{\sigma}) = 0$, the isovel of infinite speed $\sigma = \bar{\sigma}$ serves as a "starting line" for the streamlines, which they leave at right angles, in view of (36).

Finally the Jacobian J for the transformation from the (σ, ψ) -plane to the physical plane is given by

$$J = \kappa\kappa_\sigma = (\rho q^2)^{-1},$$

and consequently $0 < J < +\infty$ for $\bar{\sigma} < \sigma < +\infty$. The transformation of the region $\sigma > \bar{\sigma}$ upon the physical plane is accordingly single-valued. A region of the physical plane may, however, be covered more than once by the flow, in view of the spiral character of the streamlines mentioned above.

BIBLIOGRAPHY

1. F. Tricomi, *On linear partial differential equations of mixed type*, Translation A9-T-26, Brown University (1948), from *Atti Accad. Naz. Lincei* vol. 14 (1923) pp. 134-247.
2. L. Bers, *On the continuation of a potential gas flow across the sonic line*, NACA Tech. Note 2058 (April, 1950).
- G. Guderley and H. Yoshihara, *The flow over a wedge profile at Mach number one*, AF Tech. Rep. 5783 (July, 1949).
- C. Loewner, *A transformation theory of the partial differential equations of gas dynamics*, NACA Tech. Note 2065 (April, 1950).
- S. Tomotika and K. Tomada, *Studies on two-dimensional transonic flows of a compressible fluid*, I, *Quart. Appl. Math.* vol. 7 (1950) pp. 381-397. II, *Quart. Appl. Math.* vol. 8 (1950) pp. 127-136.

⁶ For the details see the paper by Hansen and Martin [7].

- A. Weinstein, *Transonic flow and generalized axially symmetric potential theory*, Symposium on Theoretical Compressible Flow, U.S. Naval Ordnance Laboratory (June, 1949) pp. 73-82.
3. F. I. Frankl, *On the problems of Chaplygin for mixed sub-and-supersonic flows*, Translation NACA Tech. Mem. 1155, from Bull. Acad. Sci. URSS vol. 9 (1945) pp. 121-143.
4. M. H. Martin, *Steady, rotational, plane flow of a gas*, Amer. J. Math. vol. 72 (1950) pp. 465-484; in particular, p. 471.
5. E. Goursat, *Leçons sur l'intégration des équations aux dérivées partielles du second ordre à deux variables indépendantes*, Vol. 2, Paris, 1898, pp. 241-295.
6. R. Mises and M. Schiffer, *On Bergman's integration method in two-dimensional compressible fluid flow*, Part II in *Advances in Applied Mechanics*, Academic Press, Inc., New York, 1948.
7. R. Courant and K. O. Friedrichs, *Supersonic flow and shockwaves*, Interscience Publishers, Inc., New York, 1948, p. 380.
- M. J. Lighthill, *The hodograph transformation in trans-sonic flow*, I, *Symmetrical channels* Proc. Roy. Soc. London Ser. A vol. 191 (1947) pp. 323-341.
- A. G. Hansen and M. H. Martin, *Some geometrical properties of plane flows*, Proc. Cambridge Philos. Soc. vol. 47 (1951) pp. 763-776.
8. C. A. Stewart, *Advanced calculus*, Methuen & Co., Ltd., London, 1940, p. 503.
9. J. A. Tierney, *An approximation to transonic flow of a polytropic gas*, Thesis, University of Maryland, 1951.
10. S. B. Jackson, *A class of spirals*, Duke Math. J. vol. 18 (1951) pp. 673-682.

INSTITUTE FOR FLUID DYNAMICS AND APPLIED MATHEMATICS, UNIVERSITY OF MARYLAND,
COLLEGE PARK, MD.

ON GRAVITY WAVES

BY

ALBERT E. HEINS

1. Introduction. We shall be concerned here with some problems of surface waves which give rise to boundary-value problems for Laplace's equation in two or three dimensions. A simple example of such mathematical problems deals with the solution of the two-dimensional Laplace's equation subject to the boundary condition that the normal derivative is proportional to the function on the unit circle. In surface-wave theory, the constant of proportionality is positive, thus affecting the standard uniqueness proof which this problem possesses when the constant is negative [1]. This particular problem has been discussed by Boggio in 1912 [2]. The corresponding boundary-value problem for an infinite domain has many interesting features, for among other things it arises in the linear theory of gravity waves [3]. For example, let us consider a channel of uniform finite depth, with a rigid bottom and a free surface. In the linear theory, we are called upon to solve Laplace's equation subject to the boundary condition described above on the free surface and to the normal derivative's vanishing on the rigid surface. The nature of such solutions in two dimensions was first dealt with in detail by Weinstein [4,5], who demonstrated that there are only two linearly independent bounded solutions in this strip. This work of Weinstein initiated a series of investigations by Hoheisel [6], Bochner [7], Poritsky [8], Cooper [9], and Heins [10], all of whom discussed this question in various fashions.

In 1948, another series of investigations pertaining to such channels was initiated. At that time, Heins [11] discussed the effect of a progressive wave on the free surface incident upon a semi-infinite dock. In 1950, these results were extended to a submerged plane barrier by the same author [12]. It has been noted by Peters [13] in 1950 that there were what one might call "floating-mat" types of free surfaces. This type of free surface obeys the same type of boundary condition as the ordinary free surface save for the fact that the constant of proportionality may either be positive or negative. For a positive constant it is possible to admit traveling waves into the mat. The problem of joining a floating mat to an ordinary free surface with traveling waves propagating in each of these surfaces has been studied by Weitz and Keller [14] and brought within the proper scope of the methods for solution by Heins [15].

For channels of infinite depth in the presence of such obstacles or discontinuities in geometry as we have described above, a considerable amount of progress has been made. For the effect of a progressive wave on a dock we have the work of Friedrichs and Lewy [16] and Heins [17]. Recently, Greene [18] has discussed the submerged semi-infinite barrier, while Skinner and Heins [31] have discussed the joining of two different "free surfaces." Other con-

figurations have been worked out for such channels. Ursell [19] and Dean [20] consider the effect of a traveling wave on a vertical plane barrier, while John [21] has discussed the effect of such waves on inclined barriers.

Other geometries have been dealt with, but we shall not pursue this matter here. Rather, we shall concern ourselves with channels of finite or infinite depth with certain special obstacles which make possible the explicit solution of the boundary-value problem at hand. Thus the work on sloping beaches and overhanging cliffs will not be dealt with here, for the mode of formulation and the methods of solution are quite different from the present ones which we propose to discuss. We might mention that the work of Kreisel [22], which deals with cylindrical obstacles in channels of finite depth, and that of John [21] fall into this category. On the other hand all the problems we shall discuss come within the scope of integral equation methods. As such, while we shall use freely the methods of analytic functions [23], our problems will not necessarily be of the two-dimensional type. In this respect our results are to be contrasted to those of Friedrichs and Lewy [16], Isaacson [24], John [21], Kreisel [22], Lewy [25], Miche [26], and Stoker [27].

2. Basic Equations [3]. We shall describe here the linearized equations governing gravity waves. Let us suppose that the fluid medium is nonviscous and incompressible and that the motion is irrotational. Then there exists a velocity potential $\Phi(x, y, z, t)$ which satisfies Laplace's equation

$$(1) \quad \Phi_{xx} + \Phi_{yy} + \Phi_{zz} = 0.$$

Here x, y, z are the usual rectangular coordinates, with x measured along the undisturbed free surface, y measured vertically up from the undisturbed free surface, and z measured along the free surface at right angles to x , while t is the time variable. On a rigid surface, the normal derivative of Φ vanishes, *i.e.*, the normal component of the flux velocity is zero. On a free surface, for small displacements and velocities we have

$$(2) \quad g\Phi_y + \Phi_{tt} = 0,$$

where g is the acceleration of gravity measured in units appropriate to those of x, y, z , and t . Equation (2) is a product of the energy integral of the equations of motion, neglecting terms beyond the linear ones in the velocity and displacement of the free surface. The only external force acting is gravity, whence the term gravity waves. In particular, if we assume that $\Phi(x, y, z, t)$ has a monochromatic time dependence of the form $\exp(-i\omega t)$, we have as basic equations, upon suppressing the time factor,

$$(1') \quad \Phi_{xx} + \Phi_{yy} + \Phi_{zz} = 0$$

in the medium;

$$(2') \quad \Phi_n = 0$$

on a rigid barrier, and

$$(3) \quad \Phi_y = \beta\Phi, \quad (\beta = \omega^2/g),$$

on a free surface. We should like to emphasize here that β is positive and therefore provides us with a certain amount of difficulty regarding uniqueness theorems [1].

If, instead of a single free surface at $y = 0$, we consider two semi-infinite "free surfaces" joined along the line $x = 0$, we have a similar situation. Suppose that one of the "free surfaces" arises from the fluid medium, while the other free surface is a field of floating particles which do not interact. Under certain linearizing assumptions, it is found that

$$(4) \quad \Phi_y = \beta_1 \Phi$$

on this second type of free surface [13]. (The time factor has again been suppressed.) Here

$$\beta_1 = \frac{\delta g}{\delta g - \delta_1 \omega^2},$$

where all symbols have been defined save the δ 's. δ_1 is the density of the floating material per unit area, and δ is the density of the nonviscous, incompressible medium. Clearly β_1 has no definite signature.

We shall consider here two types of regions bounded above by a free surface of some type: the channel of uniform finite depth and the channel of infinite depth. The channel of finite depth is an infinite slab of finite width and may be described mathematically as

$$-\infty < x < +\infty, \quad -a \leq y \leq 0, \quad -\infty < z < +\infty;$$

while the channel of infinite depth is a half space

$$-\infty < x < +\infty, \quad y < 0, \quad -\infty < z < +\infty.$$

In the channel of finite depth, the solutions of (1) are

$$(5) \quad \exp(\pm ikx \pm ikz) \cosh \rho_0 \frac{y+a}{a},$$

or

$$(6) \quad \exp(\pm \kappa_n x - ikz) \cos \rho_n \frac{y+a}{a},$$

where ρ_0 is the real positive root of the transcendental equation

$$(7) \quad \rho \sinh \rho - a\beta \cosh \rho = 0.$$

Equation (7) also possesses two sequences of imaginary roots $i\rho_n$ and $i\rho_{-n}$, where

$$\rho_n = -\rho_{-n}, \quad (n = 1, 2, \dots).$$

Here

$$\kappa_n = \left[k^2 + \left(\frac{\rho_n}{a} \right)^2 \right]^{\frac{1}{2}} > 0, \quad \kappa = \left[\left(\frac{\rho_0}{a} \right)^2 - k^2 \right]^{\frac{1}{2}} > 0.$$

Note that we may have wave motion in the plane $y = 0$, provided $\rho_0/a > |k|$.

Such waves are called *surface waves*, because they are confined to the surface $y = 0$. If we use the terminology of plane-wave theory, it is appropriate to introduce a parameter α to describe the propagation normal of the plane wave. This parameter α is an angle measured with respect to the positive x -axis such that

$$\cos \alpha = \pm \frac{\kappa a}{\rho_0}, \quad \sin \alpha = \pm \frac{\kappa a}{\rho_0}.$$

We shall consider cases here for which κ is real, and therefore wave motion exists in the plane $y = 0$. It is to be observed that the cutoff for the wave motion, *i.e.*, the point at which κ becomes imaginary, is in contrast to what occurs in electromagnetic and acoustical ducts [28].

The study of the nature of the solutions in channels of finite depth was considered by Airy, who found the periodic solutions for the case $k = 0$. To find all the solutions described above, an eigenvalue method has been described by Weinstein [1]. Several other workers have given modifications of this method [6-10]. The only bounded solutions of (1) are (5). The nature of these bounded solutions is of importance in describing the boundary conditions at infinity in some of our later work. For the floating-mat type of "free surface," there may or may not be wave motion, depending in part on the sign of β_1 .

For a channel of infinite depth, the bounded solutions are

$$\exp(\pm i\sigma x \pm ikz) \exp(\beta y), \quad (y < 0),$$

where now

$$\sigma = (\beta^2 - k^2)^{\frac{1}{2}},$$

and σ is real.

We shall assume henceforth in this work that Φ has a z factor $\exp(\pm ikz)$, so that (1) becomes

$$(1'') \quad \Phi_{xx} + \Phi_{yy} - k^2\Phi = 0,$$

upon suppressing this factor. For this reason we shall consider obstacles in channels which are cylinders with generators parallel to the z axis, or more specifically planes whose edges are parallel to the z axis.

3. Green's functions and representations for $\Phi(x,y)$. A Green's function for a channel of finite depth or infinite depth may be viewed as a singular solution of (1''). To be more precise, it satisfies (1'') save at some point $P'(x',y')$ in the channel. At this point the Green's function becomes infinite as the logarithm of the distance between the points $P(x,y)$ and $P'(x',y')$. In the neighborhood of the point $P'(x',y')$, we find that the Green's function is of the order $(1/2\pi) \ln r$, where $r = [(x - x')^2 + (y - y')^2]^{\frac{1}{2}}$; that is, it has a two-dimensional source. Now we impose the boundary conditions (2') and (3), with the added boundary condition at infinity that there are only outward-going waves (*i.e.*, we impose the Sommerfeld "Ausstrahlungsbedingung" for channels), and we find [29, 12] that the Green's function $G(x,y,x',y')$ for a

channel of finite depth is

$$(8) \quad \sum_{n=1}^{\infty} \frac{(\rho_n^2 + a^2\beta^2)[\cos \rho_n(a + y)/a][\cos \rho_n(a + y')/a]}{(\rho_n^2 + a^2\beta^2 - a\beta)(\rho_n^2 + a^2k^2)^{\frac{1}{2}}} \exp \left[-(\rho_n^2 + a^2k^2)^{\frac{1}{2}} \frac{|x - x'|}{a} \right] + i \frac{(\rho_0^2 - a^2\beta^2)[\cosh \rho_0(a + y)/a][\cosh \rho_0(a + y')/a]}{a\kappa(\rho_0^2 - a^2\beta^2 + a\beta)} \exp (i\kappa|x - x'|).$$

For $x \gg x'$ we observe that G is asymptotic to

$$\cosh \left(\rho_0 \frac{a + y}{a} \right) \exp (i\kappa x),$$

a traveling wave to the right, while for $x \ll x'$, G is asymptotic to

$$\exp (-i\kappa x) \cosh \rho_0,$$

a traveling wave to the left. The source P serves to generate these outward-going waves at infinity. Such a Green's function may be viewed as a "wave maker" [30].

Since

$$\exp (i\kappa|x - x'|) = \cos \kappa(x - x') + i \sin \kappa|x - x'|,$$

and since $\cos \kappa(x - x')$ is a solution of the homogeneous equation (1''), it may be omitted from G without changing the sourcelike character of G , but now the Sommerfeld condition is violated. By the same token we may add a term $\pm i \sin \kappa(x - x')$ to $i \sin \kappa|x - x'|$, thus changing the conditions at infinity to one of attenuation in one direction and boundedness in the other. We shall have occasion to make use of this device [12].

There is a second Green's function for channels of finite depth which we may call a "docklike" Green's function. It satisfies the boundary conditions of the rigid surface on the lower and upper surfaces. This source function is not a "wave maker" like the previous one which we have described, and yet both of them are useful in providing representations for $\Phi(x, y)$ in a channel. The Green's function which satisfies boundary conditions that its normal derivative vanishes at $y = 0$ and $y = -a$ is

$$(9) \quad G^{(3)}(x, y, x', y') = \sum_{n=0}^{\infty} \frac{\cos (n\pi y/a) \cos (n\pi y'/a)}{(a^2k^2 + n^2\pi^2)^{\frac{1}{2}}} \exp \left\{ -|x - x'| \left[k^2 + \left(\frac{n\pi}{a} \right)^2 \right]^{\frac{1}{2}} \right\}.$$

In order to fix our attention on a specific problem, let us examine Fig. 1. We have here a submerged barrier, *i.e.*, a semi-infinite rigid plane of zero thickness. Waves are induced on a free surface for $x \rightarrow \pm \infty$, and we are interested especially in the reflection and transmission properties of this particular barrier.

For $x \rightarrow -\infty$, $-a \leq y \leq 0$, we have that $\Phi(x,y)$ is asymptotic to

$$[\alpha_1 \exp (i\kappa x) + \alpha_2 \exp (-i\kappa x)] \cosh \rho_0 \frac{y+a}{a},$$

(see Sec. 2). For $x \rightarrow \infty$, $-b \leq y \leq 0$, it is asymptotic to

$$[\alpha_3 \exp (i\kappa'x) + \alpha_4 \exp (-i\kappa'x)] \cosh \rho_0' \frac{y+b}{b},$$

where

$$\kappa' = \left[\left(\frac{\rho_0'}{b} \right)^2 - k^2 \right]^{\frac{1}{2}},$$

and κ' is assumed real. Further, ρ_0' is the real positive root of

$$\rho \sinh \rho - b\beta \cosh \rho = 0.$$

Under the barrier, $\Phi(x,y)$ is asymptotic to [12]

$$\exp (-|k|x), \quad (x \rightarrow \infty, -a \leq y \leq -b).$$

α_1 and α_3 may be viewed as the amplitudes of the waves traveling to the right in $x < 0$ and $x > 0$, respectively, while α_2 and α_4 are the amplitudes of the waves traveling to the left in the same regions. The solution of this problem

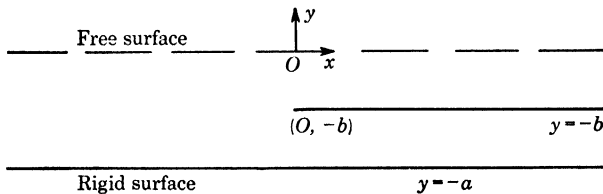

FIG. 1

will provide us with two linear relations between these coefficients. With proper normalization we may define two sets of reflection coefficients, that to the right and that to the left of the origin (Sec. 4).

We shall now use Green's theorem to express $\Phi(x,y)$ in terms of an appropriate Green's function and the discontinuity of Φ on the obstacle. We have already described the excitation at infinity in the previous paragraph. Upon integrating around a rectangle whose x coordinate on the left is $-L'$ and on the right L ($L', L \gg 0$), deleting the obstacle from the path, we find that

$$\Phi(x,y) = \int (G\Phi_{n'} - \Phi G_{n'}) ds',$$

where ds' is the element of arc length and the outer normal is chosen. We have assumed here that Φ is source-free, and if we can provide a traveling-wave solution for $x \gg 0$ and $x \ll 0$, this assumption will suffice. We choose for the Green's function

$$G^{(1)} = G - \frac{(\rho_0^2 - a^2\beta^2) \cosh [\rho_0(a+y)/a] \cosh [\rho_0(y'+a)/a] \sin \kappa(x-x')}{a\kappa(\beta a + \rho_0^2 - a^2\beta^2)}.$$

This serves to give us attenuation for $x \ll x'$ and a bounded term for $x \gg x'$. Now, on the free surface there are no contributions in virtue of the boundary conditions imposed on $G^{(1)}$ and Φ . The same is true of the rigid lower surface of the channel. Further, since Φ_y is zero on the submerged plane barrier, we are left with

$$\Phi(x,y) = \int_0^L \Phi(x',-b)G_{y'}^{(1)} \Big|_{y'=-b} dx' - \int_{-b}^0 [G^{(1)}\Phi_{x'} - \Phi G_{x'}^{(1)}]_{x'=-L'} dy' + \int_{-b}^0 [G^{(1)}\Phi_{x'} - \Phi G_{x'}^{(1)}]_{x'=-L} dy',$$

where $[\Phi]$ is the discontinuity of Φ on the submerged plane barrier. As for the integrals at $-L'$ and L , we can assert the following: Since the Green's function vanishes exponentially for $x \ll x'$ and since Φ is assumed to be bounded there at the most, it is clear that there will be no contributions as $L \rightarrow \infty$. For the left side, that is, for $L' \rightarrow \infty$, we have that $\Phi(x,y)$ is asymptotic to

$$[\alpha_1 \exp (i\kappa x) + \alpha_2 \exp (-i\kappa x)] \cosh \rho_0 \frac{a+y}{a}.$$

Upon using the asymptotic form of the Green's function $G^{(1)}$ and noting the order conditions involved, we have finally, as $L' \rightarrow \infty$,

$$(10) \quad \Phi(x,y) = \int_0^\infty [\Phi]G_{y'}^{(1)} \Big|_{y'=-b} dx' + [\alpha_1 \exp (i\kappa x) + \alpha_2 \exp (-i\kappa x)] \cosh \rho_0 \frac{a+y}{a}.$$

Here we have a representation for Φ in terms of the boundary conditions at infinity (on the left) and the discontinuity on the barrier. An integral equation may be formed by noting that Φ_y vanishes on the barrier, and we are left with [12]

$$(11) \quad \int_0^\infty [\Phi]G_{yy'} \Big|_{y=y'=-b} dx' + \frac{\rho_0}{a} [\alpha_1 \exp (i\kappa x) + \alpha_2 \exp (-i\kappa x)] \sinh \rho_0 \frac{a-b}{a} = 0, \quad (x > 0).$$

We shall have more to say in Sec. 4 about the response under the free surface and under the barrier. Suffice it to be noted that the asymptotic form of Φ for $x \rightarrow \infty$ does not enter into the formulation of the integral equation. This is a result of the special Green's function which we have employed. It is significant to note that the discontinuity of Φ on the barrier is the unknown quantity. If this were known, we could use equation (10) to determine $\Phi(x,y)$ everywhere in the duct.

To pursue this last remark further, let us divide the duct into two regions. Let the strip $-\infty < x < +\infty$, $-b \leq y \leq 0$ be one region, and let $-\infty < x < +\infty$, $-a \leq y \leq -b$ be the other. Then it is now possible to express

$\Phi(x,y)$ in each region in terms of Φ_y for $y = -b$, with the aid of appropriate Green's functions. For the first region, let us choose a Green's function which satisfies the free-surface condition on the surface $y = 0$ and the condition that the y derivative vanishes on the line $y = -b$. Further let us put conditions at infinity on the Green's function which gives us attenuation for $x \gg x'$ and boundedness for $x \ll x'$. That is, save for changes in notation this is basically the Green's function which we employed in the first formulation of the problem. Then if this Green's function is called $G^{(2)}$, we have in the upper region

$$\Phi(x,y) = [\alpha_3 \exp (i\kappa'x) + \alpha_4 \exp (-i\kappa'x)] \cosh \left(\rho_0 \frac{y+b}{b} \right) - \int_{-\infty}^0 G^{(2)} \Phi_{y'} \Big|_{y'=-b} dx'.$$

Now if we introduce a "docklike" Green's function for the second region and call it $G^{(3)}$, we have simply that $\Phi(x,y)$ in the lower region has the representation

$$\Phi(x,y) = \int_{-\infty}^0 G^{(3)} \Phi_{y'} \Big|_{y'=-b} dx'.$$

For $y = -b$, $x < 0$, $\Phi(x,y)$ is continuous. Hence we have

$$(12) \quad \int_{-\infty}^0 (G^{(3)} + G^{(2)}) \Phi_{y'} \Big|_{y'=-b} dx' - [\alpha_3 \exp (i\kappa'x) + \alpha_4 \exp (-i\kappa'x)] = 0.$$

Note that we have, then, two different formulations: one in terms of the discontinuity of Φ on the barrier and the other in terms of Φ_y on the extension of the barrier. Of course, a knowledge of this Φ_y will produce a representation of Φ in the upper region which will give us the same information that the discontinuity of Φ did for the first formulation. This leads us to an interesting mathematical question regarding the inversion of one problem to obtain the other, but we shall not pursue this matter here. Suffice it that we note that (11) and (12) are integral equations of the Wiener-Hopf type [23] because of the $x - x'$ variation of the kernels and the semi-infinite range of integration (see Sec. 5).

The problem of ducts of finite or infinite depth involving the joining of two free surfaces [15, 31] or the problem of a channel of infinite depth [18] with a submerged, plane, semi-infinite barrier under similar conditions of excitation may be formulated in a similar fashion as integral equations of the Wiener-Hopf type. The mathematical difficulties encountered in solving the problems of infinite depth are greater than for those of finite depth.

4. Reflection and transmission properties: reciprocity relations. In the problem which we have formulated in detail in Sec. 3, we have the following situation: For $x \rightarrow -\infty$, $-a \leq y \leq 0$, we have that $\Phi(x,y)$ is asymptotic to

$$[\alpha_1 \exp (i\kappa x) + \alpha_2 \exp (-i\kappa x)] \cosh \rho_0 \frac{y+a}{a},$$

and for $x \rightarrow \infty$, $-b \leq y \leq 0$, it is asymptotic to

$$[\alpha_3 \exp (ik'x) + \alpha_4 \exp (-ik'x)] \cosh \rho_0' \frac{y+b}{b}.$$

It turns out that $\Phi(x,y)$ is source-free, so that an application of Green's theorem to Φ and its complex conjugate Φ^* gives us immediately

$$\int (\Phi \Phi_n^* - \Phi^* \Phi_n) ds = 0.$$

The boundaries of the strip, to start with, are the free surface, the lines $x = -L'$ and $x = L$, and the lower rigid boundary. With the customary care observed for the presence of the submerged barrier in forming the path of integration, we note that, because of the special asymptotic forms of $\Phi(x,y)$ for the horizontal surfaces, we are simply left with contributions from the lines $x = -L'$ and $x = L$. Indeed from the order conditions which we have on these lines for L and L' sufficiently large, we are left with two terms which are independent of L and L' and terms which depend upon these quantities but which approach zero uniformly as L and L' become infinite. Thus for the problem formulated in Sec. 3, when L and L' become infinite, we have the relation

$$\frac{\kappa a (|\alpha_1|^2 - |\alpha_2|^2) (\rho_0^2 - \beta a - \beta^2 a^2)}{\rho_0^2 - \beta^2 a^2} = \frac{\kappa' b (|\alpha_3|^2 - |\alpha_4|^2) (\rho_0'^2 - \beta b - \beta^2 b^2)}{\rho_0'^2 - \beta^2 b^2}.$$

Of the four α 's, only three have magnitudes that are independent.

This last relation has deeper implications than a mere check on the magnitudes of the α 's. For example, suppose that α_4 is zero. Then we have a wave incident from the left on the barrier, a reflected one to the left from the barrier, and a transmitted one to the right. Let us rewrite the above equation, with $\alpha_4 = 0$, in the following fashion:

$$1 - \frac{|\alpha_2|^2}{|\alpha_1|^2} = \frac{\kappa' b (\rho_0'^2 - \beta b - \beta^2 b^2) (\rho_0^2 - \beta^2 a^2)}{\kappa a (\rho_0^2 - \beta a - \beta^2 a^2) (\rho_0'^2 - \beta^2 b^2)} \frac{|\alpha_3|^2}{|\alpha_1|^2}.$$

Then $|\alpha_2/\alpha_1|^2 = r_1^2$ is the reflection coefficient to the left, and as a result of [12], is simply

$$|r_1|^2 = \left(\frac{\kappa' - \kappa}{\kappa' + \kappa} \right)^2,$$

while $(1 - |r_1|^2)^{\frac{1}{2}} = |t_1|$ is the transmission coefficient to the right, and

$$|t_1|^2 = \frac{4\kappa'\kappa}{(\kappa' + \kappa)^2}.$$

In a similar fashion, if α_1 is taken to be zero, then we have incidence and reflection on the right and transmission on the left. In this case the reflection and transmission coefficients are the same as above. The transmission coefficients as defined in [12] are not normalized.

If we examine the reciprocity relations for the other configurations we

described at the end of Sec. 3, we shall find that similar relations hold; *i.e.*, the squares of the magnitudes of the amplitudes occur in the same form, but the external geometric factors are different for each problem. This, of course, enables us to define reflection and transmission coefficients for each of these problems, once the asymptotic forms of $\Phi(x,y)$ for each individual problem are determined.

The case $b = 0$, for the problem in Sec. 3, deserves some special comment. In this case we have

$$|\alpha_1| = |\alpha_2|$$

indicating that there is complete reflection and no transmission for this case. For such problems as these, we expect a traveling-wave solution, and we are thus compelled to introduce a second solution which is out of phase from the first solution at infinity. The method of obtaining this solution has been discussed in [11] and its mathematical and physical implications in [1].

5. Mathematical methods. The integral equations encountered for the horizontal submerged barriers or the joining of two free surfaces are of the Wiener-Hopf type [23]. That is, their limits run from zero to infinity, and their kernels are of the convolution type. As such there is mathematical machinery available to solve them, since the kernels and the desired functions possess appropriate growth to permit application of the complex Fourier transform theorem. The Fourier transform theorem enables us to write the solutions of these integral equations in contour-integral form and in particular to find asymptotic developments for the solutions as $x \rightarrow \infty$. We find that these transform methods lean heavily upon the methods of functions of a single complex variable [23]. With the asymptotic developments we can determine the amplitudes of the waves going to the right and left for $|x| \rightarrow \infty$. Appropriate normalization (see Sec. 4) determines right and left transmission coefficients. The special analytical methods worked out in [18] enable us to handle the joining of two free surfaces in a channel of infinite depth. Uniqueness may be discussed in relation to the Wiener-Hopf integral equation to be solved. More general uniqueness theorems under less restrictive conditions are not completely available for this class of problems.

6. Other problems. For the case $k = 0$, Ursell [19] has shown that, for a vertical barrier of finite length drawn from the free surface down or for a semi-infinite barrier submerged a finite distance from the free surface, one encounters an integral equation of a fairly simple type. Again a simple transformation brings Ursell's integral equation back to one of the Wiener-Hopf type with appropriate growth properties for the kernel and the unknown function. Ursell, however, did not use these methods, since others were available for solution.

Limiting cases of several of the problems we have described produce interesting sidelights. For example, if $b = 0$, *i.e.*, if the barrier is on the surface of the channel, we have the dock problem. For channels of finite depth this has been treated in [11], while for channels of infinite depth this appears incidentally

in [18]. A second singular solution is required in these cases to form traveling-wave solutions on the free surface, for in this case there is no transmission under the dock and there is total reflection on the left. The procedure required to determine the second solution has been described in [11]. Other interesting cases appear by varying the parameter β_1 . For example, the problem of plane stress in a semi-infinite medium with partially stiffened edge, treated by E. Buell, appears for $\beta_1 \rightarrow \infty$ and $k = 0$, from the problem of joining two free surfaces over a channel of infinite depth with a minor change in the other boundary condition. The case $k = 0$, incidentally, in the work of semi-infinite domains requires a certain amount of delicate analysis for extraction. In the case $k = 0$, $\beta_1 = 0$, we get the "dock" problem with waves at normal incidence to the dock [16].

BIBLIOGRAPHY

1. A. Weinstein, *On gravity waves*, Can. J. Math. vol. 1 (1949) pp. 271-278.
2. T. Boggio, *Sulle funzioni di variabile complessa in un'area circolare*, Atti Accad. Sci. Torino vol. 47 (1912) pp. 22-37. See also E. Goursat, *Cours d'analyse mathématique*, Vol. 3, Gauthier-Villars & Cie, Paris, 1927, p. 240.
3. H. Lamb, *Hydrodynamics*, Dover Publications, New York, 1945, Chap. IX.
4. A. Weinstein, *Sur un problème mixte pour les fonctions harmoniques*, Atti Accad. Naz. Lincei Ser. 6 vol. 6 (1927) pp. 259-265.
5. ———, *Sur un problème aux limites dans une indéfinie*, C. R. Acad. Sci. Paris vol. 184 (1927) pp. 497-499.
6. G. Hoheisel, *Randwertaufgaben und funktionale Differential-gleichungen*, Jber. Deutschen Math. Verein. vol. 39 (1930) pp. 54-58.
7. S. Bochner, *Vorlesungen über Fouriersche Integrale*, Akademische Verlagsgesellschaft m.b.H., Leipzig, 1932, p. 167.
8. H. Poritsky, *On a mixed boundary condition for harmonic functions*, Bull. Amer. Math. Soc. vol. 44 (1938) pp. 723-725.
9. J. I. B. Cooper, *A mixed boundary value problem*, J. London Math. Soc. vol. 14 (1939) pp. 124-128.
10. A. E. Heins, *A mixed boundary value problem; some remarks on a problem of A. Weinstein*, Bull. Amer. Math. Soc. vol. 49 (1943) pp. 130-133.
11. ———, *Water waves over a channel of finite depth with a dock*, Amer. J. Math. vol. 70 (1948) pp. 730-748.
12. ———, *Water waves over a channel of finite depth*, Can. J. Math. vol. 2 (1950) pp. 210-222.
13. A. S. Peters, *The effect of a floating mat on water waves*, Comm. Pure Appl. Math., N.Y.U. vol. III (1950) pp. 319-354.
14. M. Weitz and J. Keller, *Reflection of water waves from floating ice in water of finite depth*, Comm. Pure Appl. Math., N.Y.U. vol. III (1950) pp. 305-318.
15. A. E. Heins, *Some remarks on the coupling of two ducts* (forthcoming).
16. K. O. Friedrichs and H. Lewy, *The dock problem*, Comm. Pure Appl. Math., N.Y.U. vol. I (1948) pp. 135-148.
17. A. E. Heins, *Water waves over a channel of infinite depth with a dock*, Bull. Amer. Math. Soc. vol. 53 (1947) p. 1122.
18. T. R. Greene, Doctoral dissertation, Carnegie Institute of Technology, June, 1951.
19. F. Ursell, *The effect of a vertical barrier on surface waves in deep water*, Proc. Cambridge Philos. Soc. vol. 43 (1947) pp. 374-382.
20. W. R. Dean, *On the reflection of surface waves by a submerged plane barrier*, Proc. Cambridge Philos. Soc. vol. 41 (1945) pp. 231-238.

21. F. John, *Waves in the presence of an inclined barrier*, Comm. Pure Appl. Math., N.Y.U. vol. I (1948) pp. 149–200.
22. G. Kreisel, *Surface waves*, Quart. Appl. Math. vol. 7 (1949) pp. 21–44.
23. R. E. A. C. Paley and N. Wiener, *The Fourier transform in the complex domain*, Am. Math. Soc. Colloquium Pub. vol. XIX (1934) Chap. IV.
24. E. Isaacson, *Water waves over a sloping bottom*, Comm. Pure Appl. Math., N.Y.U. vol. III (1950).
25. H. Lewy, *Water waves on sloping beaches*, Bull. Amer. Math. Soc. vol. 52 (1946) pp. 737–775.
26. M. Miche, *Mouvements ondulatoires de la mer en profondeur constante ou décroissante*, Ann. ponts et chaussées vol. 114 (1944) pp. 25–78, 131–164, 270–292, 369–406.
27. J. J. Stoker, *Surface waves in water of variable depth*, Quart. Appl. Math. vol. 5 (1947) pp. 1–54.
28. Lord Rayleigh, *The theory of sound*, Vol. II, Macmillan & Co., Ltd., London, 1940, Sec. 268.
29. A. Sommerfeld, *Die Greensche Funktion der Schwingungsgleichung*, Jber. Deutschen Math. Verein. vol. 21 (1912) pp. 300–353.
30. F. Ursell, *The wave making properties of a submerged pulsating source*, Ad. Res. Lab. Rep. ARL/R.1/103.41/w (1946) Teddington.
31. R. O. Skinner and A. E. Heins (forthcoming).

CARNEGIE INSTITUTE OF TECHNOLOGY,
PITTSBURGH, PA.

HYDRODYNAMICS AND THERMODYNAMICS

BY

S. R. DE GROOT

1. Introduction. The hydrodynamical equations are developed from the viewpoint of the thermodynamics of irreversible processes. This procedure allows an insight into the fundamental concepts and the logical structure of hydrodynamics; the form of the hydrodynamical equations depends on the character of the laws of thermodynamics which are chosen as starting points. The place of the phenomenon of viscous flow among other irreversible processes is most clearly shown when systems are considered in which viscous flow, heat conduction, diffusion, and chemical reactions can occur simultaneously.

In studying the fundamental concepts of the hydrodynamics of viscous media, it is necessary to consider the theory of thermodynamics, because, as will be shown, the form of the hydrodynamical equations depends on the choice made for the initial equations of the laws of thermodynamics. As viscous flow is an irreversible phenomenon, the theory to be used is the relatively new branch of science called "*thermodynamics of irreversible processes*" [1, 2].

In Sec. 2 the derivation of the hydrodynamical equations from a thermodynamical basis is given. The theory of "hydrothermodynamics" contains four fundamental equations:

- I. The law of conservation of mass
- II. The force equation (equation of motion)
- III. The energy equation ("first law of thermodynamics")
- IV. The entropy equation of Gibbs ("second law of thermodynamics") supposed, as a rule, to hold along the center-of-gravity motion of the system

From these four laws an entropy-balance equation can be derived which indicates that the change in entropy per unit mass is a result of a divergence of an entropy flow and of a production of entropy. The latter quantity, which is usually called source strength of entropy, results from the action of irreversible processes which take place inside the system. The expression characterizes the irreversibility of the processes, and it always has the form of a sum of products of so-called "fluxes" and "forces."

The next step in the thermodynamics of irreversible processes is to establish linear, so-called "phenomenological," relationships between these "fluxes" and "forces." For viscous media the viscous-pressure tensor p_{ij} ($i, j = 1, 2, 3$, the Cartesian coordinate directions) is found among the "fluxes" and the velocity-gradient tensor $\partial v_i / \partial x_j$ among the "forces." The linear relation between these quantities contains the viscosity coefficient η and gives a physical significance to p_{ij} , which was only formally introduced in the force equation.

The flows, expressed as linear functions of the forces, can be inserted into the fundamental laws and into the expression for the entropy production. In

particular, in the case of viscous flow, insertion of p_{ij} as function of $\partial v_i/\partial x_j$ into the force equation yields the Navier-Stokes equation of hydrodynamics; insertion into the entropy-production formula yields the Rayleigh dissipation function.

The above procedure shows the logical structure of the derivation of the hydrodynamical equations. To show the role of viscous flow among other irreversible phenomena, a system is considered in Sec. 2 in which, in addition to viscous flow, the irreversible processes of heat conduction, diffusion, and chemical reactions can take place. In Sec. 4 a few alternative forms of the fundamental laws are discussed.

In Sec. 3 a recent development in hydrodynamics, which illustrates how dependent the subject is upon thermodynamics, is briefly discussed. When, for some reason, the transfer of momentum between the various components of a mixture is inhibited, one cannot apply the entropy law in its usual form, as discussed above. Instead of having an entropy law, valid along the center-of-gravity motion of the mixture, one must now write down separate entropy laws for the constituents, valid along the macroscopic mean motion of each component. Then, following the same line of argument already given, one finally obtains equations of motion for the components, which are of a fundamentally different character from that of the Navier-Stokes equation. These new equations are just the equations of motion which describe the phenomena in liquid helium II, considered as a mixture of "normal" and "superfluid" atoms.

2. Hydrothermodynamics of systems of several components. In this section the thermodynamics of a system which is a mixture of n components $k (= 1, 2, \dots, n)$ is developed [1-4]. It is supposed that the following processes are possible: motion of mixture as a whole (bulk motion), viscous flow, heat conduction, diffusion, phenomena under the influence of external forces (*e.g.*, electrical or gravitation forces), chemical reaction (for the sake of simplicity one single chemical reaction is taken), and finally certain cross phenomena between the processes mentioned.

a. The fundamental laws. First a quantitative formulation of the four fundamental equations is given. (Some alternative forms are discussed in Sec. 4.)

I. THE LAW OF CONSERVATION OF MASS. The simplest form of the law of conservation of mass is

$$(1) \quad \rho \frac{dc_k}{dt} = -\operatorname{div} \mathbf{J}_k + \nu_k J_c, \quad (k = 1, 2, \dots, n).$$

In this equation ρ is the density; ρ_k and $c_k = \rho_k / \sum_{k=1}^n \rho_k = \rho_k / \rho$ are the density and the concentration of component k . Also the time derivative is taken with respect to the center-of-gravity motion; it will be referred to as the barycentric, substantial time derivative and equals

$$(2) \quad \frac{d}{dt} = \frac{\partial}{\partial t} + \mathbf{v} \cdot \text{grad},$$

where $\partial/\partial t$ is the local time derivative and where

$$(3) \quad \mathbf{v} = \frac{\sum_{k=1}^n \rho_k \mathbf{v}_k}{\rho}$$

is the center-of-gravity velocity, \mathbf{v}_k being the velocity of component k . The flow of component k with respect to the center-of-gravity motion is

$$(4) \quad \mathbf{J}_k = \rho_k(\mathbf{v}_k - \mathbf{v}), \quad (k = 1, 2, \dots, n).$$

The term $\nu_k J_c$ in (1) describes the production per unit volume per unit time of matter of the species k by means of a chemical reaction. The quantity ν_k divided by the molecular mass of substance k is proportional to the stoichiometric number of k in the chemical reaction, and since the total chemical production vanishes, the sum $\sum_{k=1}^n \nu_k = 0$. The quantity J_c is called the chemical reaction rate in mass per unit volume per unit time.

II. THE FORCE EQUATION. The force equation (equation of motion) can be written as

$$(5) \quad \rho \frac{d\mathbf{v}}{dt} = \text{div } \mathbf{\Pi} + \sum_{k=1}^n \mathbf{F}_k \rho_k,$$

where $\mathbf{\Pi}$ is the pressure tensor (with components π_{ij}). The vector with components $\sum_{i=1}^3 \partial \pi_{ij} / \partial x_i$ is denoted by $\text{div } \mathbf{\Pi}$. The pressure tensor is equal to

$$(6) \quad \pi_{ij} = -p \delta_{ij} + p_{ij}, \quad (i, j = 1, 2, 3),$$

where p is the hydrostatic pressure, δ_{ij} is the Kronecker symbol (0 when $i \neq j$, 1 when $i = j$), and p_{ij} is the viscous-pressure tensor. Finally \mathbf{F}_k is the external force per unit mass on component k .

III. THE ENERGY EQUATION. We can express the energy equation ("first law of thermodynamics") in the following form:

$$(7) \quad \frac{dq}{dt} = \frac{du}{dt} + p \frac{dv}{dt} - v \left(\mathbf{p} : \text{grad } \mathbf{v} + \sum_{k=1}^n \mathbf{F}_k \cdot \mathbf{J}_k \right).$$

Here dq is the heat added per unit mass, u is the internal energy per unit mass (*i.e.*, the total energy per unit mass with the exclusion of the barycentric kinetic energy $\frac{1}{2} \mathbf{v}^2$), $v = \rho^{-1}$ is the specific volume (not to be confused with \mathbf{v} , the barycentric velocity), and $\mathbf{p} : \text{grad } \mathbf{v}$ denotes the tensor product

$\sum_{i,j=1}^3 p_{ij} \partial v_i / \partial x_j$ (here $\text{grad } \mathbf{v} = \partial v_i / \partial x_j$ is the tensor formed as the dyad product of the vectors ∇ and \mathbf{v}). One can introduce the heat flow \mathbf{J}_q by means of the relation

$$(8) \quad \rho \frac{dq}{dt} = - \text{div } \mathbf{J}_q.$$

It should be noted that the time derivatives in (7) and (8) are derivatives (2) with respect to the motion of the center of gravity.

IV. THE ENTROPY EQUATION. The entropy equation ("second law of thermodynamics") is Gibbs' law

$$(9) \quad T \frac{ds}{dt} = \frac{du}{dt} + p \frac{dv}{dt} - \sum_{k=1}^n \mu_k \frac{dc_k}{dt},$$

where s is the specific entropy (entropy per unit mass), μ_k the chemical potential (partial specific Gibbs function) of component k , and T the temperature. The derivatives are again supposed to be substantial derivatives (2) with respect to the center of gravity. From the viewpoint of macroscopic physics the use of (9) for irreversible processes, *i.e.*, outside equilibrium, is of course a new postulate, but its application can be justified by means of statistical mechanics for a large class of irreversible phenomena, as has been shown by Prigogine [5]. He has shown for the Chapman-Enskog model that statistical mechanics gives the same results as those obtained by applying the thermodynamics of irreversible processes using equation (9), provided that the distribution function of the particle velocities can properly be described as

$$(10) \quad f = f^{(0)} + f^{(1)},$$

where $f^{(0)}$ is the Maxwell-Boltzmann equilibrium distribution and $f^{(1)}$ the first Chapman-Enskog correction. Fortunately, for almost all irreversible processes, (10) is a sufficient approximation so that the thermodynamical theory can legitimately be based on formula (9). In (9) the derivatives must be counted with respect to the center-of-gravity motion of the mixture, because the velocity distribution f in (10) is, in a first approximation, $f^{(0)}$, that is, an equilibrium distribution around the center-of-gravity motion. This latter state of affairs is a result of normal transfer of momentum between the various components of the mixture. (When this transfer is inhibited for some reason, completely different expressions are obtained, as is explained in Sec. 3.)

b. The entropy balance. From the fundamental laws the entropy-balance equation can be easily calculated. When dc_k from (1) and du from (7) with (8) are substituted in (9), the following equation is obtained:

$$(11) \quad \rho \frac{ds}{dt} = - \text{div } \mathbf{J}_s + \sigma,$$

with

$$(12) \quad \mathbf{J}_s = \frac{\mathbf{J}_q - \sum_{k=1}^n \mu_k \mathbf{J}_k}{T},$$

$$(13) \quad \sigma = \frac{1}{T} \left(\vec{p} : \text{Grad } \mathbf{v} + \mathbf{J}_q \cdot \mathbf{X}_q + \sum_{k=1}^n \mathbf{J}_k \cdot \mathbf{X}_k + J_c A \right),$$

and where

$$(14) \quad \mathbf{X}_q = \frac{-\text{grad } T}{T},$$

$$(15) \quad \mathbf{X}_k = \mathbf{F}_k - T \text{ grad } \left(\frac{\mu_k}{T} \right), \quad (k = 1, 2, \dots, n),$$

$$(16) \quad A = - \sum_{k=1}^n \nu_k \mu_k.$$

Formula (11) clearly has the form of a balance equation. The change in specific entropy s is due to two causes, the negative divergence of an entropy flow \mathbf{J}_s and an entropy production with a source strength σ . This latter quantity is seen to be the sum of the products of two sets of variables, *viz.*, the first set \mathbf{p} , \mathbf{J}_q , \mathbf{J}_k , and J_c , which are called “fluxes” (or “flows”), and the second set $\text{grad } \mathbf{v}$, \mathbf{X}_q , \mathbf{X}_k , and A , called “forces” (or “affinities”; the force A , in particular, De Donder chemical affinity). The entropy production σ is the result of the action of irreversible processes. It consists of four terms which correspond, respectively, to viscous flow, heat conduction, diffusion, and chemical reaction. The velocity of the center of gravity does not figure in the source of entropy. The bulk motion of the system is, therefore, to be considered as a reversible phenomenon.

The fluxes \mathbf{J}_k ($k = 1, 2, \dots, n$) are not independent, because from (3) and (4) it follows that

$$(17) \quad \sum_{k=1}^n \mathbf{J}_k = 0.$$

Hence, for a two-component system ($n = 2$), we can write (13)

$$(18) \quad \sigma = \frac{\mathbf{p} : \text{grad } \mathbf{v} + \mathbf{J}_q \cdot \mathbf{X}_q + \mathbf{J}_1 \cdot (\mathbf{X}_1 - \mathbf{X}_2) + J_c A}{T},$$

with one single term for the diffusion entropy source.

c. The phenomenological relations. In the thermodynamics of irreversible processes the next step is to introduce linear relationships between “fluxes” and “forces.” These relations are called the phenomenological equations. In writing these relations, no fluxes and forces must be combined which are of different tensorial character, because it is impossible for a “force” of a certain

tensorial character to give rise to a "flux" of a different tensorial character. The first term in (18) is a product of tensors, the second and the third are vector products, and the fourth is a product of scalars. So we must write

$$(19) \quad p_{ij} = \eta \left(\frac{\partial v_i}{\partial x_j} + \frac{\partial v_j}{\partial x_i} - \frac{2}{3} \delta_{ij} \sum_{l=1}^3 \frac{\partial v_l}{\partial x_l} \right), \quad (i, j = 1, 2, 3),$$

$$(20) \quad \mathbf{J}_q = L_{11} \mathbf{X}_q + L_{12} (\mathbf{X}_1 - \mathbf{X}_2),$$

$$(21) \quad \mathbf{J}_1 = L_{21} \mathbf{X}_q + L_{22} (\mathbf{X}_1 - \mathbf{X}_2),$$

$$(22) \quad J_c = LA.$$

In (19) the tensor components p_{ij} are given as linear functions of the tensor components $\partial v_i / \partial x_j$ in the usual way, when the volume viscosity is taken as zero. The "phenomenological coefficient" η which is introduced is the viscosity coefficient. Relations (20) and (21) contain vector quantities. Here cross terms arise between heat conduction and diffusion, corresponding to the phenomena of thermal diffusion and the Dufour effect. (Isotropy is assumed; otherwise the separate components of the fluxes would be linear functions of the components of the forces.) According to Onsager's theorem [6, 7], the coefficient scheme is symmetrical, so here

$$(23) \quad L_{12} = L_{21}.$$

Finally, (22) gives the connection between the scalar quantities J_c and A , introducing the chemical "drag" coefficient L .

When (19) to (23) are substituted into (18), we obtain

$$(24) \quad T\sigma = \eta \left[\frac{2}{3} \left(\frac{\partial v_1}{\partial x_1} - \frac{\partial v_2}{\partial x_2} \right)^2 + \text{cycl.} + \left(\frac{\partial v_1}{\partial x_2} + \frac{\partial v_2}{\partial x_1} \right)^2 + \text{cycl.} \right] \\ + L_{11} \mathbf{X}_q^2 + (L_{12} + L_{21}) \mathbf{X}_q \cdot (\mathbf{X}_1 - \mathbf{X}_2) + L_{22} (\mathbf{X}_1 - \mathbf{X}_2)^2 + LA^2 \geq 0,$$

an expression which is quadratic in the "forces." According to the second law of thermodynamics the entropy production (24) is essentially positive; hence

$$(25) \quad \eta \geq 0, \quad L_{11} \geq 0, \quad L_{11}L_{22} - L_{12}L_{21} \geq 0, \quad L_{22} \geq 0, \quad L \geq 0.$$

d. Results for hydrodynamics. Substitution of (19) into (5) with (6) gives

$$(26) \quad \rho \frac{d\mathbf{v}}{dt} = -\text{grad } p + \eta \left(\Delta \mathbf{v} + \frac{1}{3} \text{grad div } \mathbf{v} \right) + \sum_{k=1}^n \mathbf{F}_k \rho_k,$$

the Navier-Stokes equation of hydrodynamics. It should be remembered that, for the description of the mechanical behavior of the system, equation (21) is also required in addition to (26). The thermodynamics of irreversible processes is thus necessary for the justification of hydrodynamics. It leads to (19) and (21) at the same time, giving physical significance to p_{ik} , as well as the value of the diffusion flux \mathbf{J}_1 (which contains, as indicated by formulas

(15) and (21), typically thermodynamical quantities like the chemical potentials μ_k).

The quantity (24) is equal to the energy dissipated by irreversible phenomena. The first term is the well-known Rayleigh dissipation function of hydrodynamics, which gives the energy dissipated as a result of viscous flow.

3. Hydrothermodynamics of systems of several fluids. A striking example, which illustrates how interdependent are hydrodynamics and thermodynamics, was recently given in papers by Prigogine and Mazur [8, 9]. These authors considered mixtures of components, of such a nature that there is no normal transfer of momentum between the particles of different components; it is, however, supposed that, between particles of the same kind, ordinary transfer of momentum is possible. Such an "inhibition" of transfer of momentum between particles of different kinds may be caused by a great mass difference; *e.g.*, in a gas plasma there is only small transfer of momentum between the electrons and the ions and atoms. It will be seen that the hypothesis of inhibition of transfer of momentum between the two fluids of which liquid helium II is supposed to consist, according to the two-fluid model [10-12], has led Prigogine and Mazur to a very successful theory. The term "fluid" adopted here applies to the constituents of a mixture between which transfer of momentum is inhibited. (This use of the word fluid should not be confused with the meaning which this word often has in hydrodynamics, *viz.*, liquids and gases in general.)

The main features of the theory of a mixture of two "fluids" is given briefly below. Instead of (5), separate force equations for the two fluids must be used:

$$(27) \quad \rho_\alpha \frac{d\mathbf{v}_\alpha}{dt} = \text{div } \mathbf{\Pi}_\alpha - \boldsymbol{\lambda}_\alpha + \mathbf{F}_{\alpha\rho\alpha}, \quad (\alpha = 1, 2).$$

Here $\mathbf{\Pi}_\alpha$ is the total pressure tensor of fluid α ($= 1, 2$), and the vector $\boldsymbol{\lambda}_\alpha$ is a source of momentum, which may be produced by exchange with the other fluid. It should be noted that in general it will be assumed that chemical reactions are possible, and in the following discussion it will be supposed that the reaction $1 \rightleftharpoons 2$, where 1 and 2 are the two fluids, can take place. This reaction contributes to the quantity $\boldsymbol{\lambda}_\alpha$. The supposition of negligible momentum transfer (inhibition) means that $\boldsymbol{\lambda}_\alpha$ is a small quantity.

Instead of (9), entropy equations for both fluids, taken separately, are written down as

$$(28) \quad T \frac{ds_\alpha}{dt} = \frac{du_\alpha}{dt} + p_\alpha \frac{dv_\alpha}{dt}, \quad (\alpha = 1, 2).$$

Here the derivatives d/dt are counted along the macroscopic motion of the fluids $\alpha = 1, 2$ separately. The statistical justification for this method of introducing the entropy equations is that, as a result of the supposed inhibition, there is no velocity distribution function of the mixture which approximates to an equilibrium distribution around the center-of-gravity motion, as

in Sec. 2. Velocity distributions exist only for each fluid separately; these are, in first approximation, equilibrium distributions around the macroscopic motion of each fluid. Therefore the Gibbs equations (28) were applied for the macroscopic motion of each fluid.

A calculation along the same lines as developed in Sec. 2 gives for the equations of motion (27):

$$(29) \quad \rho_\alpha \frac{d\mathbf{v}_\alpha}{dt} = \rho_\alpha \mathbf{F}_\alpha - c_\alpha \text{grad } p \mp \rho_2 c_1 \frac{\partial s}{\partial c_1} \text{grad } T \\ \mp \frac{\rho_1 \rho_2}{\rho} \text{grad } A + \eta_\alpha \left(\Delta \mathbf{v}_\alpha + \frac{1}{3} \text{grad div } \mathbf{v}_\alpha \right) \\ - c_\alpha (\mathbf{v}_1 - \mathbf{v}_2) J_c \mp B (\mathbf{v}_1 - \mathbf{v}_2) (\mathbf{v}_1 - \mathbf{v}_2)^2, \quad (\alpha = 1, 2).$$

The upper signs refer to $\alpha = 1$, the lower to $\alpha = 2$. Further, A is the chemical affinity (16), which, for the reaction $1 \rightleftharpoons 2$, is equal to $\mu_1 - \mu_2$, and the factor B is a constant. The last two terms in the equation are seen to be of a lower order than the preceding ones.

Prigogine and Mazur applied their equations (29) to liquid helium II, which is supposed to consist of a normal fluid 1 and a superfluid 2, between which the "chemical reaction" $1 \rightleftharpoons 2$ is possible. The affinity A vanishes when it is supposed that this reaction always attains equilibrium instantaneously. Usually the viscosity η_2 of the superfluid is taken zero, and then the two equations (29), apart from the penultimate term, are identical with the equations which had been postulated by Gorter to explain the characteristic properties of helium II. This achievement of the theory of Prigogine and Mazur, which starts from the simple hypothesis of negligible transfer of momentum between the fluids of helium II, clearly illustrates how the character of the thermodynamical assumptions determines the form of the hydrodynamical equations.

The completely different character of (26) from (29) is seen, for instance, for the case of mechanical equilibrium. Then (29) gives, neglecting the last term, which is small for narrow capillaries,

$$(30) \quad \text{grad } p = \rho c_1 \frac{\partial s}{\partial c_1} \text{grad } T.$$

According to (26), however, a pressure gradient could never be balanced by a temperature gradient.

Equation (30) describes the fountain effect (thermomolecular pressure effect) in liquid helium II. It can also be found by means of thermodynamical considerations on irreversible processes which are different from the methods already outlined [13, 14].

4. Appendix on the fundamental laws. In this section a few forms of the fundamental laws, alternative to those of Sec. 2, are discussed [1].

a. The law of conservation of mass. Conservation of mass of the component k can be written as

$$(31) \quad \frac{\partial \rho_k}{\partial t} = - \text{div } \rho_k \mathbf{v}_k + \nu_k J_c, \quad (k = 1, 2, \dots, n),$$

or, with the aid of (2) and (4), as

$$(32) \quad \frac{d\rho_k}{dt} = -\rho_k \operatorname{div} \mathbf{v} - \operatorname{div} \mathbf{J}_k + \nu_k J_c, \quad (k = 1, 2, \dots, n).$$

Summed over all substances $k = 1, 2, \dots, n$ and combined with equation (3) or (17), these equations become

$$(33) \quad \frac{\partial \rho}{\partial t} = -\operatorname{div} \rho \mathbf{v},$$

$$(34) \quad \frac{d\rho}{dt} = -\rho \operatorname{div} \mathbf{v}.$$

Equation (1) is obtained from (32) and (34) by introducing the concentration $c_k = \rho_k/\rho$.

b. *The kinetic-energy equation.* The kinetic-energy equation is obtained as the scalar product of the center-of-gravity velocity \mathbf{v} and the force equation (5):

$$(35) \quad \rho \frac{d\frac{1}{2}\mathbf{v}^2}{dt} = \mathbf{v} \cdot \operatorname{div} \mathbf{\Pi} + \sum_{k=1}^n \mathbf{F}_k \rho_k \cdot \mathbf{v}.$$

c. *The energy equation.* The first law of thermodynamics is the equation (7), with (8), for the specific (internal) energy u , which, by using equations (34) and (6), can be written as

$$(36) \quad \rho \frac{du}{dt} = -\operatorname{div} \mathbf{J}_q + \mathbf{\Pi} : \operatorname{grad} \mathbf{v} + \sum_{k=1}^n \mathbf{F}_k \cdot \mathbf{J}_k.$$

If it is preferable to have the local time derivative instead of the substantial time derivative, it is more convenient to use the energy expressed per unit volume $u_v = u\rho$, because (2) and (34) give the simple relation

$$(37) \quad \rho \frac{du}{dt} = \frac{\partial u_v}{\partial t} + \operatorname{div} u_v \mathbf{v}.$$

Substituting this relation into (36) gives

$$(38) \quad \frac{\partial u_v}{\partial t} = -\operatorname{div} (\mathbf{J}_q + u_v \mathbf{v}) + \mathbf{\Pi} : \operatorname{grad} \mathbf{v} + \sum_{k=1}^n \mathbf{F}_k \cdot \mathbf{J}_k.$$

This equation is often used instead of (7) as the fundamental expression for the law of conservation of energy.

In connection with the formulation of the first law of thermodynamics in textbooks, it is of some importance to consider again equation (7), but now, for convenience, in the absence of viscous and external forces

$$(39) \quad dq = du + p dv.$$

This equation contains only intensive quantities. It can therefore be used as a general equation valid for *open* systems (*i.e.*, allowing interchange of matter and heat with the surroundings), as well as for *closed* ones (*i.e.*, allowing no passage of matter through the walls). Instead of the intensive quantities, total quantities for a system with mass M can be introduced: total heat $dQ = M dq$, total internal energy $U = Mu$, and total volume $V = Mv$. Then (39) becomes

$$(40) \quad dQ = dU + p dV - h dM,$$

where $h = u + pv$ is the specific enthalpy. For closed systems, (40) has the well-known form

$$(41) \quad dQ = dU + p dV.$$

d. The total-energy equation. The equation for the total specific energy e , which is the sum of the specific internal energy u and the specific kinetic energy $\frac{1}{2}\mathbf{v}^2$, is $e = u + \frac{1}{2}\mathbf{v}^2$. The equation for e follows from the summation of (35) and (36). By combining with (4), this gives

$$(42) \quad \rho \frac{de}{dt} = -\operatorname{div}(\mathbf{J}_q - \mathbf{H} \cdot \mathbf{v}) + \sum_{k=1}^n \mathbf{F}_k \cdot \mathbf{v}_k \rho_k.$$

This equation is often used as an alternative starting point to (7) or (36). When it is written using local time derivatives, the relation

$$(43) \quad \rho \frac{de}{dt} = \frac{\partial e_r}{\partial t} + \operatorname{div} e_r \mathbf{v},$$

analogous to (37), must be used ($e_r = e\rho$). Then (42) becomes

$$(44) \quad \frac{\partial e_r}{\partial t} = -\operatorname{div} \mathbf{J}_u + \sum_{k=1}^n \mathbf{F}_k \cdot \mathbf{v}_k \rho_k,$$

with

$$(45) \quad \mathbf{J}_u = \mathbf{J}_q + e_r \mathbf{v} - \mathbf{H} \cdot \mathbf{v}.$$

e. The entropy equation. Equation (9) was written with intensive quantities, and it can therefore be used for open as well as for closed systems. Introduction of the total quantities $S = Ms$, $U = Mu$, $V = Mv$, and $M_k = Mc_k$, where M_k is the total mass of component $k = 1, 2, \dots, n$ in the system, gives instead of (9)

$$(46) \quad T dS = dU + p dV - \sum_{k=1}^n \mu_k dM_k,$$

the usual form of the Gibbs law. (For closed systems the last term vanishes.)

In the proof of the equivalence of (9) and (46) it should be remembered that M is a variable and that the Euler relation is

$$(47) \quad Ts = u + pv - \sum_{k=1}^n \mu_k c_k.$$

The mean specific chemical potential (specific Gibbs function) is

$$(48) \quad g = \sum_{k=1}^n \mu_k c_k = u - Ts + pv.$$

f. The entropy balance. Equation (11) can be written as

$$(49) \quad \frac{\partial s_v}{\partial t} = -\operatorname{div}(\mathbf{J}_s + s_v \mathbf{v}) + \sigma,$$

when local time derivatives are used, according to

$$(50) \quad \rho \frac{ds}{dt} = \frac{\partial s_v}{\partial t} + \operatorname{div} s_v \mathbf{v},$$

where $s_v = s\rho$ is the entropy per unit volume. This equation is analogous to (37).

g. Linear transformations of fluxes and forces. Instead of the fluxes and forces of equations (13) to (16), other expressions, which are sometimes more appropriate [1-4], can be used. For instance, \mathbf{J}_s of equation (12) could be used instead of \mathbf{J}_q throughout the theory. Writing then $\mathbf{J}_s \cdot \mathbf{X}_q + \left(\sum_{k=1}^n \mathbf{J}_k \cdot \mathbf{X}'_k\right)/T$ instead of the second and third terms of (13), one must take

$$(51) \quad \mathbf{X}'_k = \mathbf{X}_k + \mu_k \mathbf{X}_q = \mathbf{F}_k - \operatorname{grad} \mu_k, \quad (k = 1, 2, \dots, n),$$

for the new force which belongs to \mathbf{J}_k .

A second possibility is the introduction of the flux

$$(52) \quad \mathbf{J}'_q = \mathbf{J}_q - \sum_{k=1}^n h_k \mathbf{J}_k,$$

which is sometimes called the "reduced heat flow." Writing now $(\mathbf{J}'_q \cdot \mathbf{X}_q + \sum_{k=1}^n \mathbf{J}_k \cdot \mathbf{X}''_k)/T$ instead of the second and third terms of (13), one obtains the force

$$(53) \quad \mathbf{X}''_k = \mathbf{X}_k + h_k \mathbf{X}_q = \mathbf{F}_k - (\operatorname{grad} \mu_k)_T, \quad (k = 1, 2, \dots, n).$$

This expression has the advantage over (15) that it does not include an arbitrary constant [1, 2].

A third example is obtained when electrical phenomena are studied. Then

the external force \mathbf{F}_k contains an electrical part $-e_k \text{grad } \varphi$ (with e_k the specific charge of component k and φ the electric potential). The question whether the chemical and the electrical potentials can be measured separately, or whether they occur only in the combination $\mu_k + e_k \varphi$ (called the electrochemical potential), can be solved by utilizing the methods of the thermodynamics of irreversible processes and adopting certain linear transformations of fluxes and forces [15].

[Note added in proof:

h. Ordinary and volume viscosity. From the assumption of isotropy alone, one would obtain

$$(54) \quad p_{ij} = \eta \left(\frac{\partial v_i}{\partial x_j} + \frac{\partial v_j}{\partial x_i} - \frac{2}{3} \delta_{ij} \text{div } \mathbf{v} \right) + \eta_v \delta_{ij} \text{div } \mathbf{v}, \quad (i, j = 1, 2, 3)$$

(where η_v is called the volume viscosity, and η is the ordinary viscosity) instead of equation (19), where it was assumed that η_v is zero. If, however, one would remain with the general equation (54), a term is to be added to the expression (24) for the entropy production, *viz.*, $\eta_v (\text{div } \mathbf{v})^2$, and a term $\eta_v \text{grad div } \mathbf{v}$ is to be added to the Navier-Stokes equation (26).

In the phenomenological relation (19) one could include linear dependence of p_{ij} on the chemical affinity A (multiplied by δ_{ij} to make it a tensor). Inversely, in equation (22) one could include linear dependence of J_c on the trace $\text{div } \mathbf{v}$ of the tensor $\text{Grad } \mathbf{v}$. These two terms represent new cross phenomena ("viscochemical" effects).]

BIBLIOGRAPHY

1. S. R. de Groot, *Thermodynamics of irreversible processes*, North-Holland Publishing Company, Amsterdam, and Interscience Publishers, Inc., New York, 1951.
2. I. Prigogine, *Etude thermodynamique des phénomènes irréversibles*, Thesis, University of Brussels, 1947.
3. C. Eckart, *The thermodynamics of irreversible processes*, Phys. Rev. vol. 58 (1940) pp. 267, 269, 919, 924.
4. J. Meixner, *Zur Thermodynamik der irreversiblen Prozesse*, Zeit. Phys. Chem. vol. B 53 (1943) p. 235; Ann. Phys. 5 vol. 43 (1943) p. 244.
5. I. Prigogine, *Le domaine de validité de la thermodynamique des phénomènes irréversibles*, Physica vol. 15 (1949) p. 272.
6. L. Onsager, *Reciprocal relations in irreversible processes*, Phys. Rev. vol. 37 (1931) p. 405, vol. 38 (1931) p. 2265.
7. H. B. G. Casimir, *On Onsager's principle of microscopic reversibility*, Rev. Mod. Phys. vol. 17 (1945) p. 343.
8. I. Prigogine et P. Mazur, *Sur deux formulations de l'hydrodynamique et le problème de l'hélium liquide II*, Physica vol. 17 (1951) p. 661.
 ———, *Sur l'hydrodynamique des mélanges liquides de He³ et He⁴*, Physica vol. 17 (1951) p. 680.
9. P. Mazur, *Thermodynamique des phénomènes de transport dans l'hélium II liquide*, Thesis, University of Utrecht, 1951.
10. L. Tisza, *Sur la théorie des liquides quantiques; application à l'hélium liquide*, J. Phys. Radium Ser. 8 vol. 1 (1940) pp. 164, 350.
11. L. D. Landau, *Two-fluid model of liquid helium II*, J. Phys. USSR vol. 5 (1941) p. 71.

12. C. J. Gorter and J. H. Mellink, *On the irreversible processes in liquid helium II*, *Physica* vol. 15 (1949) p. 285.

C. J. Gorter, *On the thermodynamics of the two-fluid model of helium II*, *Physica* vol. 15 (1949) p. 523.

———, P. W. Kasteleyn, and J. H. Mellink, *Discussion of the properties of helium II on the basis of the two-fluid model*, *Physica* vol. 16 (1950) p. 113.

13. S. R. de Groot, L. Jansen, and P. Mazur, *Non-equilibrium thermodynamics and liquid helium II*, *Physica* vol. 16 (1950) pp. 421, 691; *Phys. Rev.* vol. 81 (1951) p. 1070.

14. S. R. de Groot, *Thermodynamics of the fountain phenomenon in liquid helium II and its inverse effect*, *Physica* vol. 13 (1947) p. 555; *J. Phys. Radium Ser. 8* vol. 8 (1947) p. 188; *C. R. Acad. Sci. Paris* vol. 225 (1947) p. 173.

15. ——— and H. A. Tolhoek, *Electric and chemical potentials*, *Proc. Roy. Netherlands Acad. Sci.* vol. 54B (1951) p. 42.

INSTITUTE FOR FLUID DYNAMICS AND APPLIED MATHEMATICS, UNIVERSITY OF MARYLAND,
COLLEGE PARK, MD.

(ON LEAVE FROM INSTITUTE FOR THEORETICAL PHYSICS, UNIVERSITY OF UTRECHT,
NETHERLANDS.)

NONUNIFORM PROPAGATION OF PLANE SHOCK WAVES

BY

J. M. BURGERS

1. Introduction. In the following lines a few cases of nonuniform propagation of plane shock waves will be discussed. Since, in the one-dimensional propagation of plane waves, there is no attenuation of the wave in consequence of increase of area, nonuniformity must arise through other causes; *e.g.*, a nonhomogeneous state of the gas in which the propagation takes place, wave phenomena following in the wake of the shock wave and overtaking the latter, or the presence of an exterior force like gravity.

The treatment will be based on the Lagrangian description [1] of the motion of the gas in the wake of the shock wave.

We describe the path of an element of volume by

$$x = \varphi(s, t),$$

where the parameter s has a constant value for every individual element. The velocity of the element is $u = \varphi_t$, and its acceleration along the path is φ_{tt} . We introduce

$$\Phi = \varphi_s,$$

a quantity which measures the linear expansion of an element during its motion. Hence along a path, *i.e.*, for constant s , we have

$$\rho\Phi = \text{const.}$$

If we assume adiabatic behavior of the gas according to Poisson's law, after the shock wave has passed over the element, we also have

$$p\Phi^\gamma = \text{const.}$$

The constants in both relations will have values in general depending on s .

We introduce the path of the shock wave by means of

$$x = X(t),$$

and for the velocity of propagation of the shock wave write

$$\xi = \frac{dX}{dt}.$$

We assume that the gas through which the propagation takes place is at rest initially. The initial density, pressure, and sound velocity for the element labeled s will be denoted by ρ_0 , p_0 , c_0 , respectively. These quantities in general will be functions of s , to be obtained from the relations governing the initial state of the gas. We shall come back to this point presently.

Hugoniot's relations for the shock wave give

$$u_1 = \frac{2}{\gamma + 1} \left(\xi - \frac{c_0^2}{\xi} \right), \quad \rho_1 = \rho_0 \frac{\xi}{\xi - u_1}, \quad p_1 = p_0 + \rho_0 \xi u_1 = \rho_0 \left(\frac{c_0^2}{\gamma} + \xi u_1 \right).$$

In these expressions $u_1 = (\varphi_t)_1$ is the velocity of the element of volume immediately after the passage of the shock wave; ρ_1 and p_1 represent the density and the pressure of the element immediately after this passage. If we write Φ_1 for the value of Φ referring to the same instant, we have, at any later instant,

$$\rho\Phi = \rho_1\Phi_1, \quad p\Phi^\gamma = p_1\Phi_1^\gamma$$

for every constant s .

It is now convenient to take the parameter s equal to the coordinate x of the element of volume in its initial state, *i.e.*, before the passage of the shock wave. We then have

$$s = x = \varphi(s, t), \quad s = X,$$

along the path of the shock wave. Taking the derivative of x along the path of the shock wave, we find

$$\frac{d\varphi}{ds} = (\varphi_t)_1 \frac{dt}{ds} + (\varphi_s)_1 = 1,$$

where

$$(\varphi_t)_1 = u_1, \quad (\varphi_s)_1 = \Phi_1.$$

Moreover

$$\frac{dt}{ds} = \frac{dt}{dX} = \frac{1}{\xi}.$$

Hence we obtain

$$\Phi_1 = \frac{\xi - u_1}{\xi},$$

and

$$\rho\Phi = \rho_1\Phi_1 = \rho_0.$$

The relation between ρ_0 , p_0 , c_0 , and s can be obtained directly from the relation between these quantities and the original coordinate x of the element before it was attained by the shock wave.

The equation of motion for an element of volume in the wake of the shock wave has the form

$$\rho\varphi u = -p_x - \rho g.$$

On the right-hand side of the equation we have added a term $-\rho g$, representing the action of gravity with constant intensity g in the direction of the negative x -axis; this term should be omitted when there is no need to take account of such action. The equation can be transformed into

$$\rho_0(\varphi u + g) = -p_s = -\frac{\partial}{\partial s} (p_1\Phi_1^\gamma\Phi^{-\gamma}).$$

To determine the solution of this equation, we must specify a condition concerning what happens in the wake of the shock wave. An important case arises when the shock wave is produced by the motion of a body with a plane face perpendicular to the x -axis, driving the gas before it. In that case the condition can be given by stating the velocity of the face of the body or by prescribing an equation to which this velocity is subjected. It is convenient to write $s = 0$ for the element of volume of the gas immediately adjoining the face of the body; the condition then will refer to the form of the function $\varphi(0,t)$.

2. The method of infinite series. A first approach to the solution of the propagation problem can be made with the aid of a series development [1] for the function $\varphi(s,t)$. Such a development can be adapted to various conditions. However, since various operations must be carried out on φ or its derivatives, involving divisions and the calculation of $\Phi^{-\gamma}$, it is to be expected that the derived expressions will be convergent only in a limited domain of values of s and t . The calculations consequently cannot give more than the initial stages of the motion, but this can be helpful as a starting point for a numerical method of computation, for which the initial stages otherwise may be difficult to obtain.

By way of example, we take a case in which the undisturbed gas has a constant temperature, so that c_0 is constant. It is convenient to use units in which $c_0 = 1$. If gravity is acting, there will be a decrease of the pressure and of the density of the gas with increasing x , determined by the equation

$$\frac{dp_0}{dx} = -\rho_0 g.$$

Since

$$p_0 = \frac{\rho_0 c_0^2}{\gamma} = \frac{\rho_0}{\gamma},$$

in the units adopted, we find

$$\rho_0 = \rho_{00} e^{-\gamma g x} = \rho_{00} e^{-\gamma g s},$$

where ρ_{00} is written for the original density of the gas at the level $x = 0$.

The simplest case is obtained when the position of the advancing body producing the shock wave is given. We can then write

$$\varphi(0,t) = a_1 t + b_1 t^2 + c_1 t^3 + \dots,$$

where a_1, b_1, c_1, \dots are known quantities. We further write

$$\varphi(s,t) = a_1 t + a_2 s + b_1 t^2 + b_2 t s + b_3 s^2 + c_1 t^3 + c_2 t^2 s + c_3 t s^2 + c_4 s^3 + \dots.$$

We also assume that along the path of the shock wave the following relation holds:

$$(*) \quad t = \tau_1 s + \tau_2 s^2 + \tau_3 s^3 + \dots.$$

In these formulas $a_2, b_2, b_3, c_2, c_3, c_4; \dots; \tau_1, \tau_2, \tau_3, \dots$ are constant coefficients which must be determined. The following procedure can be applied:

(a) The condition $s = \varphi$ along the path of the shock wave makes it possible to express a_2, b_3, c_4, \dots by means of the other coefficients.

(b) We express $1/\xi = dt/ds$ and $\xi = ds/dt$ in the form of series in s , with coefficients depending on $\tau_1, \tau_2, \tau_3, \dots$.

(c) The velocity u is obtained from φ_t , and u_1 (the velocity of the gas immediately after the passage of the shock wave) can be expressed as a series in s , obtained by substituting the series (*) for t .

(d) The first Hugoniot equation

$$u_1 = \frac{2}{\gamma + 1} \left(\xi - \frac{1}{\xi} \right)$$

then makes it possible to express $\tau_1, \tau_2, \tau_3, \dots$ by means of the coefficients $b_2; c_2, c_3; \dots$.

(e) We form the series for

$$p_1 = \rho_0 \left(\frac{1}{\gamma} + \xi u_1 \right)$$

and those for Φ, Φ_1 , and $\Phi_1^2 \Phi^{-\gamma}$.

(f) These expressions are substituted into the equation of motion. Equating the terms with the same powers of s and t on both sides of the equation, we obtain a series of relations, from which the coefficients $b_2; c_2, c_3; \dots$ can be derived one after the other.

3. Approximate methods. If it is desired to obtain approximate information about the ultimate course of the shock wave, without going through the process of a complete numerical calculation, other methods of approach will be preferred. These methods either attempt to circumvent the necessity of solving the partial differential equation for φ or are directed at the construction of special solutions, applicable to particular conditions.

An example of the first type is the method developed by Brinkley and Kirkwood [2]. Although they have given their formulas in a form which is simultaneously applicable to plane, cylindrical, and spherical shock waves, we shall discuss the case of plane waves only, since this is sufficient to demonstrate the nature of the auxiliary hypothesis introduced. We leave out gravity and assume that ρ_0, p_0 , and c_0 are constants.

From Hugoniot's relations we have

$$u_1 = \frac{2}{\gamma + 1} \left(\xi - \frac{c_0^2}{\xi} \right),$$

$$p_1 = \frac{2}{\gamma + 1} \rho_0 \xi^2 - \frac{\gamma - 1}{\gamma(\gamma + 1)} \rho_0 c_0^2.$$

Differentiation along the path of the shock wave gives

$$\frac{du_1}{dt} = (u_t)_1 + \xi(u_s)_1 = \frac{2}{\gamma + 1} \left(1 + \frac{c_0^2}{\xi^2} \right) \frac{d\xi}{dt},$$

$$\frac{dp_1}{dt} = (p_t)_1 + \xi(p_s)_1 = \frac{4}{\gamma + 1} \rho_0 \xi \frac{d\xi}{dt}.$$

Now u_t and u_s can be expressed through p_s and p_t , if we make use of the equation of motion and of the equation of continuity. This gives

$$u_t = -\frac{1}{\rho_0} p_s, \quad u_s = \Phi_t = -\frac{\rho_0}{\rho^2} \rho_t = -\frac{\rho_0}{\rho^2 c^2} p_t.$$

We substitute these expressions into the formula for du_1/dt . If we eliminate $(p_s)_1$ between the formulas for du_1/dt and dp_1/dt , we obtain an equation relating $d\xi/dt$ and $(p_t)_1$. This could be turned into a differential equation for ξ alone, if we can obtain an independent expression for $(p_t)_1$. By making some further use of the expressions mentioned, it is possible to bring this equation into such a form that it gives a relation between $d\xi/dt$ and $[\partial(pu)/\partial t]_1$; the problem then is to find an independent expression for the latter quantity.

Brinkley and Kirkwood attempt to achieve this by introducing a relation between $[\partial(pu)/\partial t]_1$ and the integral

$$D = \int_{t_1}^{\infty} pu \, dt.$$

This integral is taken along the path of the element to which u_1 and p_1 refer, so that s is constant in the integration. The lower limit t_1 indicates the instant of passage of the shock wave over this particular element. Dimensional considerations make it possible to write

$$[(pu)_t]_1 = -\nu \frac{(p_1 u_1)^2}{D},$$

where ν is a numerical coefficient. To obtain the desired result, it is necessary to calculate the integral and to estimate a value for ν .

The integral represents the work done by the gas in the wake of the particular element labeled s , on the gas between this element and the shock wavefront. Hence it must be equal to the increase of the energy of the latter mass of gas, *i.e.*, to the integral

$$\int_s^{s \text{ front}} \rho_0 (c_v T - c_v T_0 + \frac{1}{2} u^2) \, ds,$$

calculated for a constant value of t , which afterward must be taken as infinite (c_v is the specific heat of the gas at constant volume, which is assumed to be a constant; otherwise more elaborate expressions would be necessary). It is assumed that for infinite t the velocity u will have decreased to zero and thus can be omitted from the integral. It is also assumed that T can be calculated from T_1 (the temperature of the element immediately after the passage of the shock wave) by considering adiabatic expansion according to Poisson's law from the pressure p_1 to the original pressure p_0 of the gas, which is supposed to represent the pressure throughout the whole gas after an infinite lapse of time, when the shock wave has decayed to an infinitely small disturbance. We then find

$$D = \int_s^{\infty} \frac{p_0}{\gamma - 1} \left[\frac{\xi - u_1}{\xi} \left(\frac{p_1}{p_0} \right)^{1/\gamma} - 1 \right] ds.$$

This integral can be considered as a quantity which exclusively depends on the relation between the shock-wave velocity ξ and s . With a given value of ν the problem is then reduced to the solution of an integrodifferential equation relating ξ and s , since along the shock-wave path $d\xi/dt = \xi d\xi/ds$.

The final difficulty is to obtain a suitable value for ν . This is precisely the point at which it is attempted to circumvent the solution of the partial differential equation for φ . Brinkley and Kirkwood indicate some simple numerical estimates, depending on certain assumptions concerning the nature of the shock wave.

The solution of the integrodifferential equation for ξ as a function of s must be achieved by numerical methods.

4. Strong shock waves. The other method, which aims at the construction of an exact solution of the equations for a particular case, can be applied in the case of a very strong shock wave [3], with a velocity of propagation ξ far exceeding the original sound velocity c_0 of the gas before the passage of the shock wave. The Hugoniot relations can then be simplified to

$$u_1 = \frac{2}{\gamma + 1} \xi, \quad \rho_1 = \frac{\gamma + 1}{\gamma - 1} \rho_0, \quad p_1 = \frac{2}{\gamma + 1} \rho_0 \xi^2.$$

We assume the following expression for $\varphi(s, t)$, in which the variables s and t are separated:

$$\varphi(s, t) = f(t)F(s) - \beta t.$$

Here $f(t)$ and $F(s)$ are unknown functions, and β is a constant.

A solution of this type is possible only with a definite law for the decrease of the original density ρ_0 with x , which law will be obtained as a result of the calculation.

The condition fixing the value of s along the shock-wave path gives

$$f(t)F(s) - \beta t = s.$$

Differentiation along the path of the shock wave leads to the formula

$$\xi = \frac{ds}{dt} = \frac{f'F - \beta}{1 - fF'}.$$

On the other hand we have

$$u = f'F - \beta = \frac{2}{\gamma + 1} \xi.$$

Hence

$$fF' = \frac{\gamma - 1}{\gamma + 1}.$$

All quantities in these formulas refer to values of s and t along the path of the shock wave.

Substitution of the expression assumed for φ into the partial differential equation (with gravity neglected) gives

$$f''F = -\frac{1}{\rho_0} \frac{\partial}{\partial s} \left(\frac{2}{\gamma + 1} \rho_0 \xi^2 f_1^\gamma f^{-\gamma} \right),$$

where f_1 has been written for the value of $f(t)$ at the path of the shock wave. Since t is a function of s along this path, we must consider f_1 as a function of s .

The equation leads to separate equations for the functions $f(t)$ and $F(s)$. The first equation has the form

$$f''f^\gamma = \text{const.}$$

In the case where γ is a rational fraction, this equation can be solved by standard procedures. A simple case is $\gamma = \frac{5}{3}$. We then write $f(t) = [w(t)]^3$ and obtain the following integral:

$$Et = (w^2 + \lambda^2)^{\frac{3}{2}} - 3\lambda^2(w^2 + \lambda^2)^{\frac{1}{2}} + \text{const.},$$

where E and λ are integration constants.

The relation $f(t)F(s) - \beta t = s$ along the shock-wave path can be brought into the form

$$F(s) = \frac{s + \beta t}{w^3}.$$

This is a relation between the function $F(s)$ and t and s or, if we prefer, between $F(s)$ and w and s . We take the derivative with respect to s and make use of the expression $F' = 1/4f = 1/4w^3$ obtained from the Hugoniot condition. We can then derive a differential equation relating w and s , of the form

$$\frac{ds}{dw} - \frac{4s}{w} = -\frac{4w^3}{3} \frac{d}{dw} \left(\frac{\beta t}{w^3} \right),$$

which can be integrated. When the integration has been performed, we obtain the function $F(s)$ from the integral

$$F = \int \frac{ds}{w^3} = \int \frac{ds}{dw} \frac{dw}{w^3}.$$

Thus we have arrived at complete expressions for the factors $f(t)$ and $F(s)$ occurring in $\varphi(s,t)$. But we must still consider the differential equation

$$\frac{1}{\rho_0 F} \frac{\partial}{\partial s} (\rho_0 \xi^2 f^\gamma) = \text{const.}$$

derived from the partial differential equation for $\varphi(s,t)$. It is evident that this equation can be satisfied only when a special choice is made with respect to the function $\rho_0(s)$. The equation can be used to deduce the appropriate form, and the following result is found:

$$\rho_0 = \text{const.} \frac{w^5 (dw/ds)^3}{(w^2 + \lambda^2)^{\frac{3}{2}}}.$$

If we take $\lambda = 0$, or, what practically comes to the same, consider the solution for very large values of w , the expressions simplify very much, and we arrive at the results

$$t \sim w^3, \quad s \sim w^4,$$

along the path of the shock wave, and

$$\rho_0 \sim s^{-1}.$$

This means that in the original state of the gas we must have

$$\rho_0 \sim x^{-1}.$$

Such a law of density decrease can perhaps be realized when there is a particular type of temperature distribution and an appropriate intensity of gravity. Since we have assumed a relatively low value of c_0 and consequently a low temperature of the gas in the initial state, it would be possible to satisfy equilibrium conditions with very small values of g . The neglect of gravity in the equation of motion then would not introduce a great error.

It is possible to take account of a constant value of g without losing the possibility of obtaining an exact solution. The resulting expressions become slightly more complicated.

BIBLIOGRAPHY

1. J. M. Burgers, *Aerodynamical problems connected with the motion of a cloud of gas emitted by Nova Persei*, Proc. Roy. Acad. Sci. Amsterdam vol. 50 (1947) p. 262.
2. S. R. Brinkley, Jr., and J. G. Kirkwood, *Theory of the propagation of shock waves*, Phys. Rev. vol. 71 (1947) p. 606.
3. W. P. Robbertse and J. M. Burgers, *Solutions of the equations of motion for the non-uniform propagation of a very strong shock wave*, Proc. Roy. Acad. Sci. Amsterdam vol. 52 (1949) pp. 958-1067.

LABORATORIUM VOOR AERO- EN HYDRODYNAMICA, TECHNISCHE HOOGESCHOOL,
DELFT, HOLLAND

THEORY OF PROPELLERS

BY

THEODORE THEODORSEN

1. Introduction. During the past decades the classical propeller theory has attained a solid scientific status. Earlier theories were of an empirical nature, involving arbitrary assumptions which were not easy to justify. This difficulty was even more apparent in the case of counterrotating propellers. Certain propeller theories contained so many arbitrary assumptions that it became difficult to judge the results. Also the treatments tended to become very extensive.

In this regard an exact treatment is particularly superior. The relationships become transparent and simple. Compact formulas can be written for the pertinent quantities.

The problem, like most engineering problems, is really not one of accuracy but rather one of precision of treatment. It is always desirable to have a *precise* treatment, since this is the simplest to use for analysis of problems. While it is true that the exact treatment affords basis for ultimate accuracy, this is often a secondary consideration. The accuracy desired depends entirely on the nature of the problem.

To define the propeller problem, only the field of flow surrounding the propeller need be considered. We shall confine ourselves to the so-called *ideal case*, defined as the case involving minimum induced loss. It can be proved (the proof is omitted in this short treatment) that this case obtains when the surface of discontinuity far behind the propeller behaves like a solid surface, *i.e.*, when it displaces itself backward at a constant velocity.

The flow function φ is defined for the flow around such a solid spiral surface displacing itself backward at a constant velocity w . The surface may, of course, be a multiple spiral surface with multiplicity equal to the number of propeller blades. The surfaces are considered to be equidistant, corresponding to equally spaced propeller blades. One has, as the next step, to solve the Laplacian $\nabla^2\varphi = 0$ with the boundary condition indicated on the spiral surface and with velocity zero at infinity. Because of the spiral symmetry one need only determine the value of φ along a radial line on the surface. Note that the spiral is specified by the number of blades p and the spiral angle $\tan^{-1} \alpha = \lambda$. The spiral surfaces are therefore specified by the parameters p and λ .

The dual spiral surfaces behind counterrotating propellers also are subject to the condition that the loading for optimum efficiency must be such as to produce surfaces of discontinuity which displace themselves backward at a constant rate. The solution of the Laplacian proceeds in identical manner. The spiral symmetry is replaced by a cell or repetition symmetry. The significant function φ is no longer a function entirely of the radial distance but depends also on the angle or time.

Values of φ were first given by Goldstein in 1929 for several values of the parameters p and λ . It is of no concern in this connection that the treatment only applied to infinitely light loading. The significant function φ is merely dependent on the parameters p and λ ; it does not matter that λ depends on the loading or any other quantity.

Values of φ for dual, or counterrotating, propellers were obtained by the author in 1944. To obtain an ideal dual propeller, it is, strictly speaking, not sufficient to prescribe the radial distribution along the blade, since there is also change with time, and this change is different at each point along the radius. While such a propeller is theoretically possible, it is of no practical value, since the fluctuations with time around the mean value are small and any possible gain could not be justified. Tabulated values [12] are thus given simply as a function of the radius, representing the mean value with respect to time.

Referring back to the definition of the ideal propeller, we repeat that, once the significant function φ is available, one is immediately *in position to obtain the pertinent engineering quantities*.

Note in particular that it is not necessary to consider the field near the propeller for the calculations of thrust, torque, or induced loss. These quantities are completely given by the conditions far behind the propeller, as follows from mechanics. It can further be shown that the problem of profile drag can be considered independently. Note also that the problem of the actual design of the propeller blades does not enter, except as a final step, if and when this needs to be taken.

2. Mass coefficient. We shall first proceed to calculate a quantity termed the *mass coefficient*, which is a dimensionless quantity κ defined as follows:

$$(1) \quad \kappa = \int_{\tau} \frac{v_z}{w} \frac{d\tau}{\pi R^2 z_1}.$$

In this integral v_z is the velocity along the axis of the propeller (pointing backward), w is the rearward axial displacement velocity mentioned before, R is the radius of the wake spiral (at infinity), and $d\tau$ is an element of space. The integral is to be taken over a cylinder in space of infinite radius and a height z_1 equal to a whole number of spiral axial spacings, or to a very large quantity.

Obviously the quantity κ is simply the effective mass or momentum of the air mass behind the propeller in terms of a reference mass which represents a quantity of cross-sectional area πR^2 moving rearward with a constant velocity w equal to the displacement velocity.

By performing the integration

$$(2) \quad \int_{\tau} v_z d\tau,$$

first along the z -axis, one has

$$(3) \quad \int dF \int_0^h v_z dz$$

But the second integral is simply

$$(4) \quad \int_0^h v_z dz = \varphi_2 - \varphi_1 = \Gamma.$$

This difference equals the jump in the value of φ on the opposite sides of the surface of discontinuity. The integral is taken for an axial distance $z = h$ corresponding to the distance between two *adjacent* spirals. The symbol Γ is more familiar as the value of the circulation at the corresponding radial point of the propeller blade. The value of Γ remains constant along a vortex line extending spirally rearward from the propeller.

The expression for the mass coefficient thus becomes

$$(5) \quad \kappa = \int_F \frac{\Gamma}{hw} \frac{dF}{\pi R^2}.$$

The integral is to be taken within the circle of radius R , since Γ disappears beyond that radius. Now dF can be written in polar coordinates as $dF = r d\varphi_0 dr$, and if Γ is not a function of the angle φ_0 , this integration may be performed. Also the quantity

$$(6) \quad K = \frac{\Gamma}{hw}$$

may be introduced as a nondimensional circulation function, since hw has the dimension of circulation and, in fact, represents the limiting value of the circulation when each element within the circle of radius R moves rearward with a uniform velocity w . This quantity K , being nondimensional, is more convenient than the dimensional quantity Γ and has been used in all reference tables. Note that

$$(7) \quad K \leq 1.$$

The mass coefficient is therefore written in the form

$$(8) \quad \kappa = \int_0^R K \frac{r d\varphi_0 dr}{\pi R^2} = 2 \int_0^1 K(x)x dx.$$

Note that K is a function of the radius only, where x is the dimensionless radius r/R .

There is thus a simple relation between the mass coefficient κ and the circulation function $K(x)$. The mass coefficient is simply equal to the *mean value of the circulation function* taken over the area of the unit circle.

3. Thrust. The equation of motion can be reduced to one for stationary flow by superimposing the velocity $-w$. Obviously this procedure makes the vortex pattern stationary and the velocity at infinity equal to $-w$. The Bernoulli equation is therefore

$$(9) \quad p + \frac{1}{2}\rho(v - w)^2 = p_0 + \frac{1}{2}\rho w^2,$$

in which the velocities are vector quantities and p_0 is the pressure at an infinite radius. Reduced, the equation reads

$$(10) \quad p - p_0 + \frac{1}{2}\rho v^2 = \rho w v_z.$$

For a large number of blades in a counterrotating propeller the velocity vector v approaches v_z , which in turn approaches w , the displacement velocity. Hence

$$(11) \quad v \rightarrow v_z \rightarrow w,$$

and the above relation reads

$$(12) \quad p - p_0 = \frac{1}{2}\rho w^2.$$

In other words, there is an excess pressure over the pressure at infinity. This pressure exists between the (closely spaced and rigid) vortex sheets.

Expressions for thrust and loss may be formulated using a control surface commonly employed in mechanics. Let the control surface be a cylinder coaxial with the propeller axis z and with a diameter infinitely large compared with the diameter R of the wake spiral. Let the cylinder be terminated by plane surfaces perpendicular to the axis and located infinitely far behind and ahead of the propeller. For unit time the *increase* in momentum within the control surface is given for a very short time by the surface integral

$$(13) \quad dM_1 = V dt \int_S \rho v_z dS.$$

Further, the *loss* in momentum across the rear control plane is given by the surface integral

$$(14) \quad dM_2 = dt \int_S (p - p_0 + \rho v_z^2) dS,$$

this integral to be taken over the infinite plane control surface. Replacing $p - p_0$ from the Bernoulli equation (10) gives

$$(15) \quad dM_2 = dt \int_S (\rho w v_z - \frac{1}{2}\rho v^2 + \rho v_z^2) dS.$$

Combining the equations (13) and (15) for the increase in momentum and for the loss in momentum, one has

$$(16) \quad \frac{dM}{dt} = \rho \int_S [(V + w)v_z + v_z^2 - \frac{1}{2}v^2] dS.$$

Note that the expression gives the *instantaneous* thrust of the propeller. This is sufficient for the single-rotating propeller, but the thrust varies periodically with time, at least by a small amount, for the dual type. To obtain the exact value of the thrust, it is therefore necessary to obtain the thrust as a mean value for a certain length of time.

Since all quantities involved are functions of $z - wt$, we may replace dt

by dz/w and integrate with respect to z . Because of the periodicity it is sufficient to integrate for a length z equal to the distance h between successive vortex sheets. The expression for this case becomes a volume integral

$$(17) \quad M = \rho \int_{\tau} [(V + w)v_z + v_z^2 - \frac{1}{2}v^2] d\tau.$$

The integral is to be taken for a length h along the infinite cylinder. The thrust T is then

$$(18) \quad T = \frac{\rho}{h} \int_{\tau} [(V + w)v_z + v_z^2 - \frac{1}{2}v^2] d\tau.$$

This expression thus gives properly the mean thrust for a long period of time. It gives, of course, also the thrust itself, in case the thrust does not vary with time.

The three parts of the volume integral may be reduced as follows: The first part has the form

$$(19) \quad \int_{\tau} v_z d\tau = \int_S dS \int v_z dz = \int_S \Gamma dS,$$

since $\int_{\Gamma} v_z dz$ taken for the length of one spacing h is identical with Γ , or the circulation function at the corresponding point on the blade. But since, by equation (6)

$$(20) \quad \Gamma = whK,$$

and with $F = \pi R^2$, the area of the circle, one has finally for the first part

$$(21) \quad \int_{\tau} v_z d\tau = hwF \int K \frac{dS}{F} = hwF\kappa.$$

The first part is therefore equal to a constant times the mass coefficient κ .

The third part also may be reduced to a recognizable form

$$(22) \quad \int_{\tau} v^2 d\tau = \int_S \varphi \frac{\partial \varphi}{\partial n} dS,$$

where S is now the surface of the spiral within the volume considered. This may be written

$$(23) \quad \int_S \varphi \frac{\partial \varphi}{\partial n} dS = \int_S \Gamma w dS.$$

Except for the factor w this is identical with the first integral (19) and (21), or therefore

$$(24) \quad \int_{\tau} v^2 d\tau = w^2 h F \kappa.$$

This integral multiplied by the factor $\frac{1}{2}\rho$ is seen to represent something like the loss in the wake, since it includes the axial, tangential, and radial components of the induced velocity v .

The second term of the integral (18) is finally

$$(25) \quad \int_{\tau} v_z^2 d\tau,$$

which is one of the component parts of the previous integral. By analogy with equation (24) one may write at once

$$(26) \quad \int_{\tau} v_z^2 d\tau = hw^2F\epsilon,$$

where ϵ is termed the *axial-loss factor*, while κ may be called the *total-loss factor* (instead of the mass coefficient).

Evidently

$$(27) \quad \epsilon \leq \kappa \quad \text{or} \quad \frac{\epsilon}{\kappa} \leq 1.$$

The numerical value of T may be obtained for any case, since φ is known. Fortunately, the functional dependency on the factor containing ϵ is small, as will be indicated in the following.

Substituting for the three parts of the original integral (18), this is found to become

$$(28) \quad T = \rho F w \kappa \left[V + w \left(\frac{1}{2} + \frac{\epsilon}{\kappa} \right) \right].$$

We shall give the thrust in the form of a nondimensional coefficient

$$(29) \quad C_s = \frac{T}{\frac{1}{2} \rho V^2 F} = 2\kappa \bar{w} \left[1 + \bar{w} \left(\frac{1}{2} + \frac{\epsilon}{\kappa} \right) \right]$$

where $\bar{w} = w/V$.

Note here that F refers to the (circular) cross section of the wake infinitely far behind the propeller.

4. Loss. To obtain the instantaneous loss in the wake by a similar treatment, we have

$$(30) \quad \frac{d\mathcal{E}}{dt} = \int_S \left[\frac{1}{2} \rho v^2 V + \left(p - p_0 + \frac{1}{2} \rho v^2 \right) v_z \right] dS.$$

Eliminating $p - p_0$ by (9), as before, the expression is

$$(31) \quad \frac{d\mathcal{E}}{dt} = \rho \int_S \left(v_z^2 w + \frac{1}{2} v^2 V \right) dS.$$

Integrating over time and then changing to a volume integral, as was done for the thrust, gives at once

$$(32) \quad \mathcal{E} = \frac{\rho}{h} \int_{\tau} \left(v_z^2 w + \frac{1}{2} v^2 V \right) d\tau.$$

From (24) and (26) one finds

$$(33) \quad \mathcal{E} = \rho \kappa w^2 F \left(\frac{1}{2} V + \frac{\epsilon}{\kappa} w \right),$$

or in nondimensional coefficient form

$$(34) \quad e = \frac{\varepsilon}{\frac{1}{2}\rho V^3 F} = 2\kappa\bar{w}^2 \left(\frac{1}{2} + \frac{\epsilon}{\kappa} \bar{w} \right).$$

5. Power and ideal propeller efficiency. With the thrust coefficient C_s and loss coefficient e given, the sum is the supplied power or torque in the same coefficient form

$$C_p = C_s + e = 2\kappa\bar{w} \left[1 + \bar{w} \left(\frac{1}{2} + \frac{\epsilon}{\kappa} \right) \right] + 2\kappa\bar{w}^2 \left(\frac{1}{2} + \frac{\epsilon}{\kappa} \bar{w} \right),$$

or

$$(35) \quad C_p = 2\kappa\bar{w}(1 + \bar{w}) \left(1 + \frac{\epsilon}{\kappa} \bar{w} \right).$$

The ideal efficiency is therefore

$$(36) \quad \eta = \frac{C_s}{C_p} = \frac{1 + \bar{w}[\frac{1}{2} + (\epsilon/\kappa)]}{(1 + \bar{w})[1 + (\epsilon/\kappa)\bar{w}]}$$

By using the expressions $C_s = f_1(\bar{w})$ in (29) and $C_p = f_2(\bar{w})$ in (35) above, \bar{w} in (36) may be replaced by C_s or C_p . These are important relations, since they give the ideal efficiency directly as a function of thrust or power. Using the former, one has

$$(37) \quad \eta = \frac{(\frac{1}{2} + A)[\frac{1}{2} + (\epsilon/\kappa)]^2}{[(\epsilon/\kappa) + A][\frac{1}{2} + (\epsilon/\kappa)(\frac{1}{2} + A)]}$$

where

$$(38) \quad A^2 = \frac{1}{4} + \frac{1}{2} \left(\frac{1}{2} + \frac{\epsilon}{\kappa} \right) \frac{C_s}{\kappa}.$$

The expression for η as a function of the power factor leads to a third-degree equation. It is given in tabular forms for convenient use [12]. Note that the only additional parameter that appears in any of the efficiency formulas is the ratio ϵ/κ , which may be called the *fraction of axial loss* (to total loss). All results for the three different independent variables may therefore be given in simple graphs. The dependency on the parameters ϵ/κ is slight in the case of C_p and negligible in case C_s is used as independent variable. In the latter case it may be observed [12] that using the value of $\epsilon/\kappa = \frac{1}{2}$ gives an excellent mean value.

Referring back to (37) with $\epsilon/\kappa = \frac{1}{2}$, one has $A^2 = \frac{1}{4} + \frac{1}{2}C_s/\kappa$, and

$$(39) \quad \eta = \frac{2}{\frac{3}{2} + \sqrt{\frac{1}{4} + \frac{1}{2}C_s/\kappa}}.$$

It is interesting to note that this very simple formula gives the ideal efficiency with an accuracy better than 0.1 per cent, or more than needed for any technical purpose. Tables and graphs of the exact ideal efficiencies as functions of C_s , C_p , or w are given in [12].

6. Remarks. It is worth while to note that the exact theory of the propeller based on the surfaces of discontinuity is fundamentally different from the theory of the actuator disk and does not yield the latter as a limiting case. The propeller theory, based on the concept of a rigid surface of discontinuity as a matter of convenience, shows an excess pressure in the wake, while the actuator disk gives a pressure equal to that at infinity. The ideal case is based on the condition that the surface of discontinuity far behind the propeller behaves as if it were a rigid surface. The excess pressure follows as a direct consequence of this condition and so, also, do the formulas given in the paper. In this connection it may be observed that no power is required for maintaining such a rigid surface if proper mechanical means were provided for such purpose. The fact that the surface is unstable and the excess pressure is relieved may therefore be considered as the usual imperfections of the properly defined ideal case.

7. Summary. This paper contains a brief exposition of the propeller theory, giving exact expressions for thrust torque and efficiency based on the knowledge of the flow function φ , as it appears far behind the propeller. The expressions obtained depend almost entirely on one field parameter, the *mass coefficient* κ , with only a very slight dependency on a second factor ϵ , the *axial-loss factor*. As a consequence, the propeller-selection problem has been reduced to its simplest form. The blade-design problem is reduced to a final and separate step requiring only the knowledge of the usual two-dimensional section characteristics.

BIBLIOGRAPHY

1. C. N. H. Lock, *Interference velocity for a close pair of contra-rotating airscrews*, 5234, A.P. 270, N.P.L. (British) (July 22, 1941).
2. J. L. Crigler and H. W. Talkin, *Charts for determining propeller efficiency*, NACA Adv. Confid. Rep. L4129 (1944).
3. T. Theodorsen, *The theory of propellers, I, Determination of the circulation function and the mass coefficient for dual-rotating propellers*, NACA Adv. Confid. Rep. L4H03 (1944).
4. ———, *The theory of propellers, II, Method for calculating the axial interference velocity*, NACA Adv. Confid. Rep. L4119 (1944).
5. ———, *The theory of propellers, III, The slipstream contraction with numerical values for two-blade and four-blade propellers*, NACA Adv. Confid. Rep. L4J10 (1944).
6. ———, *The theory of propellers, IV, Thrust, energy, and efficiency formulas for single and dual-rotating propellers with ideal circulating distribution*, NACA Adv. Confid. Rep. L4J12 (1944).
7. S. Goldstein, *On the vortex theory of screw propellers*. Reprinted from Proc. Roy. Soc. London Ser. A, 123 (1929) p. 440.
8. K. N. Kramer, *The induced efficiency of optimum propellers having a finite number of blades*, NACA Tech. Mem. 884 (1939).
9. C. N. H. Lock and D. Yeatman, *Tables for use in an improved method of airscrew strip theory calculation*, R. & M. 1674, British ARC (1935).
10. W. F. Durand, *Aerodynamic theory*, Vol. IV, Springer-Verlag, Berlin, 1935.
11. R. von Mises, *Theory of flight*, McGraw-Hill Book Company, Inc., New York, 1945.
12. T. Theodorsen, *Theory of propellers*, McGraw-Hill Book Company, Inc., New York, 1948.

NUMERICAL METHODS IN CONFORMAL MAPPING¹

BY

G. BIRKHOFF, D. M. YOUNG, AND E. H. ZARANTONELLO

1. Introduction. The effective computation of a conformal transformation from the exterior (or interior) of a general smooth² curve \mathcal{C} onto that of a circle is of well-known importance [9]. Various methods have been proposed for solving this problem [1-3, 5, 8, 11, 14] of which Theodorsen's has been the most widely used.

We have reviewed these methods and also analogous methods for "free boundary" problems involving simply connected flows. This review seems timely, because of the advent of high-speed digital machines with a "multiplication time" of around 0.01 sec. Using such machines, existing evidence indicates that a few minutes or, in less favorable cases, a few hours of high-speed computation should suffice to give the correspondence on the boundary with an accuracy of 0.0001 radians.³

The conformal mapping problem can be "reduced" in many ways, by complex variable theory, to the solution of an appropriate *integral equation*. We have compared some of these integral equations below, with respect to their practical solvability by a *discrete, convergent, iterative* process.

We first discuss thoroughly three methods which we advocate most, for their simplicity and general applicability. For the "fixed boundary" problem, we advocate modifications of methods of Gerschgorin and Theodorsen described in Secs. 2 to 7; for the "free boundary" problem, we advocate a new method described in Secs. 8 to 10. Several other less promising methods, including a noniterative orthogonalization method, are discussed more briefly.

Our judgment has been based on analyses of the rapidity of convergence of iterative processes and of the accuracy obtainable with a given discretization. In other words, we have tried to minimize the computational effort required to obtain a given accuracy. Since we have tested our judgment in the case of a 3:2 ellipse, and considered less symmetrical regions, we believe our conclusions are reliable.

We hope this first comparative review of various proposed methods will help

¹ The results described here were largely obtained under Contract N5ori-76 Project XXII, between the Office of Naval Research and Harvard University.

² Specifically, of class $C^{(r)}$, where $r \geq 2$ and, for really precise results, $r \geq 4$; see the corollary of Sec. 4.

³ For many practical purposes, such accuracy is wasted. In general, electrolytic-tank and other analogue devices will give 1 per cent accuracy fairly easily; a precision of 0.1 per cent can be obtained only with great difficulty. The methods described below can often be supplemented by special conformal transformations, such as $w = z^n$ (to get rid of corners); for these, see A. Betz, *Konforme Abbildung*, Springer-Verlag, Berlin, 1949, or H. Kober, *A dictionary of conformal transformations*, Admiralty Computing Service, Department of Scientific Research and Experiment, London, 1945-1948.

to clarify the subject and stimulate further research, including experimentation with high-speed machines.

2. Use of Neumann kernels. Let \mathcal{C} be a simple closed curve in the complex z -plane, defined parametrically by an equation $z = z(q)$, where $z(q)$ is periodic of period 2π , so that $z(q + 2\pi) = z(q)$, $z(q)$ has at least two continuous derivatives, and $|dz/dq| > 0$. We wish to map the interior (or exterior) of \mathcal{C} conformally and one-one onto the interior (or exterior) of the unit circle $\Gamma: t = e^{i\sigma}$ in the t -plane (see Fig. 1a), by a function $t = f(z)$. We consider first the interior mapping, and suppose (without loss of generality) that \mathcal{C} contains the origin 0 and that $f(0) = 0$. We know a priori⁴ that the problem has a one-parameter family of solutions, differing by a rigid rotation of Γ .

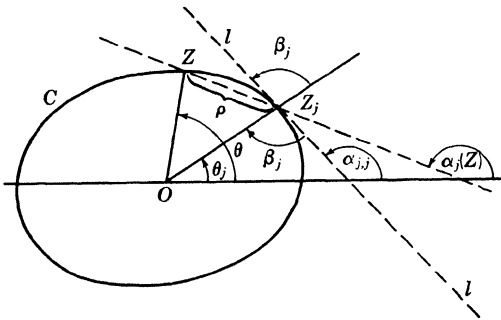

FIG. 1a

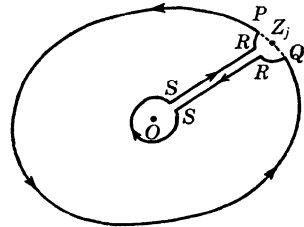

FIG. 1b

We first describe three methods for computing $f(z)$ based on integral equations having what may be called a *Neumann kernel*.

If $u(z)$ is any function, regular and harmonic inside and on \mathcal{C} , then by Green's third identity⁵ for points on \mathcal{C} , we have for all $z, z_j \in \mathcal{C}$,

$$(1) \quad u(z_j) = \frac{1}{\pi} \oint \left\{ \ln \rho_j \frac{\partial u}{\partial n} - N(z_j, z) u(z) \right\} ds,$$

where $ds = |dz|$, and $N(z_j, z) = \partial(\ln \rho_j) / \partial n = d\alpha_j / ds$ [$z - z_j = \rho_j e^{i\alpha_j}$] is the Neumann kernel. Similar formulas hold for the external mapping (signs are changed) and in three dimensions (π becomes 2π , and $\ln \rho_j$ becomes ρ_j^{-1}).

If $\partial u / \partial n$ is known (Neumann problem), then (1) becomes an integral equation in u . In principle, it can be used to find Dirichlet flows ($u = \varphi - x$) and Joukowski flows ($u = \varphi - x - c\theta$) past arbitrary bodies; it is practical for plane and axially symmetric⁶ flows.

⁴For general facts about conformal mapping, see [4]; for mapping on the boundary, see S. E. Warschawski, *Ueber das Randverhalten der Ableitung der Abbildungsfunktion bei konformer Abbildung*, Math. Zeit. vol. 35 (1932) pp. 321-456.

⁵Courant-Hilbert, *Methoden der mathematischen Physik*, Vol. 2, p. 235. See also [7, pp. 286, 385], where similar formulas are developed, but not adapted for numerical computation.

⁶L. Landweber, *The axially symmetric potential flow about elongated bodies of revolution*, David Taylor Model Basin Report 761 (1951).

In applications to conformal mapping, $\partial u/\partial n = \partial v/\partial s$, where $v(z)$ is the conjugate function of $u(z)$. It is usually $v(z)$ which is known. Moreover, since $z(q)$ is given, it is convenient to replace the intrinsic function $N(z_j, z)$ by

$$(1') \quad A(z_j, z) = \pi^{-1} \frac{d\alpha_j}{dq} = \pi^{-1} N(z_j, z) \frac{|dz|}{dq},$$

which is easily computed by (6) and (6').

One simple method [2] starts by considering

$$(2) \quad w(z) = i \ln \left[\frac{z}{f(z)} \right], \quad (w = u + iv).$$

Since \mathbb{C} contains the origin, and $f(0) = 0$, $w(z)$ will be single-valued. Using Cauchy's integral formula, since $v(q)$ is known on \mathbb{C} as

$$v = \ln r, \quad (z = re^{i\theta}),$$

we can compute $f(z)$ in the interior by a quadrature, if we can determine the "angular distortion function" $u(z) = \sigma - \theta$ on \mathbb{C} . Incidentally, $v = \ln r$ is the Green's function for the interior of \mathbb{C} and the pole 0. Then (1) becomes

THEOREM 1. *The function $u(z)$ satisfies the nonsingular, linear Fredholm integral equation ($z, z_j \in \mathbb{C}$)*

$$(3) \quad u(z_j) = \lambda \oint A(z_j, z) u(z) dq + \Phi(z_j),$$

where $\Phi(z_j) = \pi^{-1} \oint \ln r d\rho_j/\rho_j$. Here λ is 1 for the interior mapping and -1 for the exterior mapping; the Cauchy principal value of the divergent integral expressing $\Phi(z_j)$ is to be taken.

A slightly more sophisticated use of (1) was made earlier by Gerschgorin [6], using the polar angle $\sigma(z)$ instead of $\sigma - \theta$. Since σ is not regular in \mathbb{C} , he had to apply (1) to the contour \mathbb{C}^* of Fig. 1b. Passing to the limit, he obtained the integral equation

$$(3a) \quad \sigma(z_j) = \lambda \oint A(z_j, z) \sigma(z) dq - 2\beta(z_j),$$

where $\beta(z_j) = \beta_j = \alpha_{ij}$ is the angle from the radius vector to the tangent to \mathbb{C} at z_j (cf. Fig. 1a).

Similarly,⁷ Carrier [5] applied (1) to $U(z) = \text{Re} \{(\ln f(z))/z\}$. This corresponds to the potential flow inside \mathbb{C} induced by a dipole at $z = 0$, just as $f(z)$ corresponds to that of a vortex. This gives

$$(3b) \quad U(z_j) = \lambda \oint A(z_j, z) U(z) dq + 2 \text{Re} \frac{(z_j)}{|z_j|^2}.$$

As seems to be the case with all methods, the interior case leads to more theoretical and practical difficulties; since $\oint d\alpha_j = \pi$, $\lambda = 1$ is an eigenvalue for the eigenfunction $u = 1$. The resulting indeterminacy in (3) is, however,

⁷ See also W. Prager, *Phys. Zeit.* vol. 29 (1928) pp. 865-869, and W. Traupel, *Sulzer Tech. Rev.* vol. 1 (1945) p. 25.

not essential, because adding a constant to u corresponds to the indeterminacy of $f(z)$, that is, to rotating Γ rigidly. We shall avoid the complications to which it leads, by introducing the pseudo-norm

$$(4) \quad \|u\| = u_{\max} - u_{\min} = \sup_{z_j, z_k \in \mathfrak{C}} |u(z_j) - u(z_k)|,$$

which identifies functions differing by a constant.

3. Convergence of iteration process. For any $\Phi(z_j)$, the integral equation (3) can be solved by direct iteration, using

$$(3^*) \quad u_{r+1}(z_j) = \frac{\lambda}{\pi} \oint u_r(z) d\alpha_j + \Phi(z_j) = T_\lambda\{u_r(z)\}.$$

Hence the same is true of (3a) and (3b). As first proved by Poincaré,⁸ the sequence of functions defined by (3*) converges geometrically for any \mathfrak{C} and any $\Phi(z_j)$.

In fact, if \mathfrak{C} is a circle, even if 0 is not its center, then since $d\alpha_j = \frac{1}{2} ds$, for any $u_0(z)$, the $u_1(z)$ differ only by an additive constant, which expresses the inherent indeterminacy of (3), corresponding to rigid rotations of Γ . Hence convergence of the direct iteration (3*) is immediate for circular regions, and extremely rapid for nearly circular regions.

For convex regions, the argument of Neumann⁹ can be adapted to prove geometric convergence for the pseudo-norm (4). Specifically, if $u = u' - u''$, then for $\lambda = \pm 1$,

$$\|T_\lambda\{u'\} - T_\lambda\{u''\}\| = \sup \frac{1}{\pi} \int u(z) \left[\frac{d\alpha_j}{dq} - \frac{d\alpha_k}{dq} \right] dq.$$

But adding a constant to $u(z)$ affects neither $\|u\|$ nor the preceding integral. Hence we can suppose without loss of generality that $|u_{\max}| = |u_{\min}| = \frac{1}{2}\|u\|$. Substituting, we get

$$(5) \quad \|T_\lambda\{u'\} - T_\lambda\{u''\}\| \leq \sup \|u' - u''\| \cdot \frac{1}{2\pi} \int \left| \frac{d\alpha_j}{dq} - \frac{d\alpha_k}{dq} \right| dq \\ = \sup \|u' - u''\| \cdot \frac{1}{2\pi} \int \left[\frac{d\alpha_j}{dq} + \frac{d\alpha_k}{dq} - 2 \left(\frac{d\alpha_j}{dq} \frown \frac{d\alpha_k}{dq} \right) \right] dq \\ = \|u' - u''\| \cdot \left[1 - \frac{1}{\pi} \inf_{j,k} \int \left(\frac{d\alpha_j}{dq} \frown \frac{d\alpha_k}{dq} \right) dq \right],$$

where $f \frown g$ denotes g.l.b. (f, g), as usual. For convex regions, the last integral is positive.

The preceding argument has the advantage of applying also to the discretization of (3*), described in Sec. 4. However, it does not lend itself easily to sharp estimates of the rate of convergence.

⁸ Acta Math. vol. 20 (1897) pp. 59-142. Estimates of the rate of convergence are given by L. V. Ahlfors, Pacific J. Math. vol. 2 (1952) pp. 271-280; see also H. Royden, Pacific J. Math. vol. 2 (1952) pp. 385-394.

⁹ For an abstract treatment of Neumann's argument, see G. Birkhoff, *Lattice theory*, Amer. Math. Soc. Colloquium Publications, New York, 1948, pp. 264-265.

Sharper estimates can be obtained using eigenvalue theory. Thus for an ellipse the ratio of whose axis lengths is $B = b/a$, Royden⁸ has shown the largest characteristic value is $M = (1 - B)/(1 + B)$; if only solutions having fourfold symmetry are considered, it is M^2 . This would be 0.04 for the case of Table I. R. Varga¹⁰ has shown that this estimate is also correct for the discretization using $x = 3 \cos q, y = 2 \sin q$.

4. Discretization. Carrier [5] has noted that numerical integration with respect to $d\alpha_j$ is very accurate, if \mathcal{C} is smooth. This observation can be made precise.

LEMMA 1. *Let $F(q)$ be any periodic function of period 2π , and let the interval $[0, 2\pi]$ be divided into N equal parts by the points q_1, \dots, q_N . Then the trapezoidal quadrature formula*

$$(6) \quad \int_0^{2\pi} F(q) dq = \frac{2\pi}{N} \sum_{k=1}^N F(q_k) \Delta q_k$$

is "best possible."

Explanation and proof. Let $J(F) = \sum \mu_k F(q_k)$ be any other linear quadrature formula approximating to $\oint F(q) dq$, which is exact for $F(q) = \text{constant}$, so that $\sum \mu_k = 2\pi$. The error in (6) is the *average* of the errors obtained by applying $J(F)$ to $F(q)$ and its translation images $F(q + 2\pi k/N)$ [$k = 1, \dots, n$]; hence, for this class of functions, the maximum error using (6) is less than the *maximum* error obtained using $S(F)$.

COROLLARY. *If \mathcal{C} is of class $C^{(r+2)}$, if $u(q)$ is of class $C^{(r)}$, and if*

$$A_{jk} = \pi^{-1} \frac{d\alpha_j}{dq}$$

at $z = a_k$, then

$$(6') \quad \frac{2}{N} \sum_{k=1}^N A_{jk} u(q_k) - \frac{1}{\pi} \oint u(q) d\alpha_j = O(N^{-r}).$$

Hence if \mathcal{C} and $u(q)$ are of class $C^{(\infty)}$, the order of approximation is infinite.

Proof. There exist¹¹ quadrature formulas for functions of class $C^{(r)}$, whose error is $O(N^{-r})$. Hence it suffices to show that $u(q)(d\alpha_j/dq) \in C^{(r)}$. This can be proved from the identities

$$(7) \quad \pi A_{jk} = \left(\frac{d\alpha_j}{dq} \right)_{q=q_k} = \frac{(x - x_j)y' - (y - y_j)x'}{(x - x_j)^2 + (y - y_j)^2}, \quad (j \neq k),$$

$$(7') \quad \pi A_{jj} = \left(\frac{d\alpha_j}{dq} \right)_{q=q_j} = \frac{1}{2} \frac{x'y'' - y'x''}{x'^2 + y'^2},$$

¹⁰ Mr. Varga's note has been submitted to the *Pacific Journal of Mathematics*.

¹¹ See W. E. Milne, *Numerical calculus*, Princeton University Press, Princeton, N.J., 1949, Chap. IV. Thus trapezoidal quadrature is more accurate than Gauss quadrature formulas, as well as more convenient.

where primes denote differentiation with respect to q , and letters without subscripts refer to $q = q_k$ in (7) and $q = q_j$ in (7'). Setting $q_j = 0$ for notational simplicity, the continuity of $d^{r+1}(y/q)/dq^{r+1}$ at $z = z_j$ can be proved using Taylor's formula with remainder, from which $\alpha_j = \arctan [(y/q)/(x/q)]$ implies $d\alpha_j/dq \in C^{(r)}$.

Clearly $\Phi(z_j)$ in (3) is not easy to evaluate accurately. However, an accurate evaluation can be obtained as follows, writing ρ for ρ_j :

LEMMA 2. In formula (3),

$$(8) \quad \Phi(z_j) = \frac{1}{\pi} \int_{\mathcal{C}} (\theta - 2\alpha_j) d\alpha_j + \theta_j + \pi.$$

Proof. Consider the oriented contour \mathcal{C}^* sketched in Fig. 1b, composed of the arc \widehat{PQ} of \mathcal{C} , of the portions \widehat{QR} and \widehat{RP} of a circle with center z_j and radius δ , of the portion \widehat{RS} of $\widehat{Oz_j}$ between R and the circle \widehat{SS} with center O and radius δ . Since $d\rho = 0$ on \widehat{QR} , since $\ln r$ is constant on \widehat{SS} , and by cancellation, $\int \ln r d\rho/\rho$ vanishes on \widehat{QR} , on \widehat{RP} , on \widehat{SS} , and on $\widehat{RS} + \widehat{SR}$. Hence, letting \simeq signify asymptotic equality as $\delta \rightarrow 0$,

$$(9) \quad \pi\Phi(z_j) \simeq \int_P^Q \ln r \frac{d\rho}{\rho} = \oint_{\mathcal{C}^*} \ln r \frac{d\rho}{\rho} = \oint_{\mathcal{C}^*} \theta d\alpha_j = \oint_{\mathcal{C}^*} (\theta - 2\alpha_j) d\alpha_j.$$

Here the successive equalities follow from the sentence before (8), from Cauchy's integral theorem around \mathcal{C}^* applied to

$$\operatorname{Re} \left\{ \frac{\ln z dz}{z - z_j} \right\} = \ln r \frac{d\rho}{\rho} - \theta d\alpha_j,$$

and from the fact that $2\alpha d\alpha_j = d(\alpha_j^2)$, while α_j returns to its original value.

Again, $d\alpha_j = 0$ on \widehat{RS} , and $\int_S^R (\theta - 2\alpha_j)d\alpha_j$ is an infinitesimal. Hence

$$(9') \quad \pi\Phi(z_j) \simeq \int_P^Q (\theta - 2\alpha_j) d\alpha_j + \int_Q^R \theta d\alpha_j + \int_R^P \theta d\alpha_j - \int_Q^P 2\alpha_j d\alpha_j.$$

On \widehat{QR} , $\theta \simeq \theta_j + 2\pi$, where $\theta_j = \arg z_j$, while the change in α_j can be written

$$\Delta\alpha_j \simeq \alpha_j(R) - (\alpha_{jj} + \pi) = (\theta_j + \pi) - (\alpha_{jj} + \pi) = \theta_j - \alpha_{jj},$$

where α_{jj} denotes $\alpha_j(P)$. Similarly, on \widehat{RP} , $\theta \simeq \theta_j$, while

$$\Delta\alpha_j = -\pi - (\theta_j - \alpha_{jj}).$$

Hence

$$\begin{aligned} \int_Q^R \theta d\alpha_j + \int_R^P \theta d\alpha_j &\simeq (\theta_j + 2\pi)(\theta_j - \alpha_{jj}) + \theta_j(-\pi - \theta_j + \alpha_{jj}) \\ &= -\pi\theta_j + 2\pi\theta_j - 2\pi\alpha_{jj} = \pi\theta_j - 2\pi\alpha_{jj}. \end{aligned}$$

Adding $-\int_P^Q 2\alpha_j d\alpha_j = (\alpha_{jj} + \pi)^2 - \alpha_{jj}^2 = 2\pi\alpha_{jj} + \pi^2$, we have, after passing to the limit as $\delta \rightarrow 0$, formula (8).

In summary, with given N , the A_{jk} should first be computed by (7) and (7'). Then the $\Phi(z_j)$ should be computed by (8) and arithmetized to

$$(8') \quad \Phi_j = \sum_{k=1}^N A_{jk}(\theta_k - 2\alpha_{jk}) + \theta_j + \pi.$$

Finally, the $u(z_j)$ should be computed by iterating

$$(10) \quad u_{r+1}(z_j) = \lambda \sum_{k=1}^N A_{jk}u_r(z_k) + \Phi_j.$$

In the exterior case, $\lambda = -1$, and (10) will converge uniformly. In the interior case, $\lambda = +1$, and convergence will be uniform relative to the pseudo-norm (4), interpreted as $\max |u(z_j) - u(z_k)|$.

If maximum accuracy is desired, a similar modification should be made in Gerschgorin's formula (3a), since $\sigma(z)$ is not periodic. We obtained considerably greater accuracy using

$$(10a) \quad \begin{aligned} \sigma_{r+1}(z_j) &= \sum_{k=1}^N A_{jk}(\sigma_r(z_k) - 2\alpha_{jk}) + 2\theta_j + \pi \\ &= \sum_{k=1}^N A_{jk}\sigma_r(z_k) + \Psi_j, \end{aligned}$$

instead of Simpson's rule on (3a). Evidently, (10a) has a periodic integrand.

5. Comparison. The preceding methods are so similar that a comparison of them seems desirable. In all methods, the computation and storage of the A_{jk} are somewhat troublesome. To recompute the A_{jk} at each iteration, though possible, would make the method several times slower and put it at a decided disadvantage in comparison to Theodorsen's method (see Secs. 6 to 7). Hence Theodorsen's method, as modified in Sec. 7, is probably preferable for machines having a storage capacity limited to a few hundred numbers.

There is little to choose between formula (10) and the arithmetization (10a) of Gerschgorin's integral equation (3a). Partly because $u = \sigma - \theta$ is periodic, while σ is not, we incline to recommend (10). Formula (10a) may, however, give slightly more accurate results for nearly circular regions, because $2\theta_j + \pi$ is easy to calculate accurately. If many iterations are needed, it may be better to use $2N$ than N in computing $\Phi(z_j)$.

Surprisingly, at least for nearly circular regions, it is *disadvantageous* to use "improved values" $u_{r+1}(z_k)$ in place of $u_r(z_k)$, "as soon as available."

If \mathcal{C} has an *axis of symmetry*, Carrier's method has about the accuracy of the other methods and perhaps the greatest simplicity. However, it has the inconvenience that there are two constants to be determined,

$$(11) \quad a = \frac{U_{\max} - U_{\min}}{4} \quad \text{and} \quad b = \frac{U_{\max} + U_{\min}}{2},$$

before the point-to-point correspondence $\sigma = \text{arc } f(z_j)$ can be determined. One then computes σ by

$$(11') \quad \sigma_j = \cos^{-1} \left(\frac{U(z_j) - b}{2a} \right) = \cos^{-1} \tau_j.$$

Formula (11') is inaccurate near the extremes $\sigma = 0, \pi$ of U ; an error ϵ in $U(z_j)$ produces an error $O(N)$ times as large in σ_j , and hence in $u(z_j) = \sigma_j - \theta_j$. Similarly, if one tries to locate $\sigma(U_{\max})$ directly from the nearest three U_j by parabolic interpolation, the error is $O(N)$ times the average error in the U_j .

If \mathfrak{C} is symmetric about the x -axis, so that we know exactly where $\sigma = 0, \pi$, this error is greatly reduced. If \mathfrak{C} is also nearly circular, so that $U(z_j)$ is nearly $\text{Re}(z_j)/|z_j|^2$, the errors in the $U(z_j)$ may be reduced enough to make Carrier's method more accurate than those of formulas (10) and (10a). However, in general, formulas (10) and (10a) seem preferable to us.

The preceding ideas have been tested (and modified) by calculations for a 3:2 ellipse, using both arc length x and the parameter q , for which $x = 3 \cos q$, $y = 2 \sin q$, and subdivisions into 16 and 32 equal intervals. The errors resulting are tabulated in Table I.

6. Method of Theodorsen. Next consider the inverse function $x = g(t)$ mapping the interior (resp. exterior) of the unit circle Γ onto the interior (exterior) of a general, simple, closed curve \mathfrak{C} . If the interior of \mathfrak{C} is star-shaped, and so describable by an equation $r = \exp F(\theta)$ in polar coordinates, where $F(\theta)$ is single-valued, the problem can be reduced to the solution of a *singular, nonlinear* integral equation, due to Theodorsen [10, 11].

In the notation of Secs. 2 to 4, consider¹² the angular distortion $u = \sigma - \theta$ and its conjugate $v = \ln r$ on the unit circle $t = e^{i\sigma}$. Let

$$v(\sigma) = a_0 + \sum_{k=1}^{\infty} (a_k \cos k\sigma + b_k \sin k\sigma)$$

be any periodic function of period 2π , of class L_2 . We define formally the three linear operators

$$(12) \quad \begin{aligned} \mathfrak{C}v &= \sum_{k=1}^{\infty} (-b_k \cos k\sigma + a_k \sin k\sigma) = \oint C(\sigma - \sigma')v(\sigma') d\sigma', \\ \mathfrak{I}v &= \sum_{k=1}^{\infty} k^{-1}(-b_k \cos k\sigma + a_k \sin k\sigma) = \oint J(\sigma - \sigma')v(\sigma') d\sigma', \\ \mathfrak{D}v &= \sum_{k=1}^{\infty} k^{-1}(a_k \cos k\sigma + b_k \sin k\sigma) = \oint D(\sigma - \sigma')v(\sigma') d\sigma', \end{aligned}$$

¹² A. Ostrowski [9] has noted that, in (1), $t = f(z)$ could be replaced by any function $G(z)$ with $G(0) = 0$, $G'(0) \neq 0$, analytic inside Γ . This would seem comparable in its effect to making a preliminary "elementary" conformal transformation of \mathfrak{C} onto a near-circle.

TABLE I. CONFORMAL-MAPPING CORRESPONDENCE BETWEEN 3:2 ELLIPSE AND CIRCLE

Method	Map- ping	I.V.	D.V.	N	R	Error $\times 10^3$			Effort
Method 1.....	Ext.	s	u	16	0.04	0.23	0.25	0.20	} 1.5
	Int.	s	u	16	0.04	0.23	0.21	0.16	
	Ext.	s	u	32	<0.04	0.01	0.01	0.07	} 5.4
	Int.	s	u	32	<0.04	0.01	0.04	0.04	
	Ext.	q	u	16	<0.04	0.01	0.00	0.00	} 1.5
	Int.	q	u	16	<0.04	0.04	0.02	0.01	
Gerschgorin (3a)...	Ext.	σ	σ	16	0.03	0.22	0.16	0.07	} 1.5
	Int.	q	σ	16	0.04	0.21	0.22	0.13	
Gerschgorin (10a)...	Ext.	s	σ	16	0.04	0.00	0.01	0.00	} 1.5
	Int.	s	σ	16	0.04	0.04	0.03	0.01	
Carrier.....	Ext.	s	u	16	0.20	0.01	0.01	0.00	} 1.3
	Int.	s	u	16	0.25	0.04	0.04	0.03	
Carrier As.....	Ext.	s	u	16	0.10	1.48	8.21	2.13	1.39
						1.03	0.82	2.27	
	Int.	s	u	16	0.33	1.55	7.26	21.83	5.95
						3.36	1.92	7.25	
Theodorsen I.....	Ext.	σ	u	16	0.25	4.71	10.67	10.39	0.8
	Int.	σ	u	16	0.25	16.97	6.64	2.92	0.8
Theodorsen II.....	Ext.	σ	u	16	0.25	0.09	0.16	0.07	1.2
	Int.	σ	u	16	0.33	10.48	8.39	4.54	1.2
$K = K(\varphi)$	Ext.	σ	γ	16	0.33	0.13	0.16	0.09	1.4
	Int.	σ	γ	16	0.70	219.91	10.42	42.03	1.7
$\varphi = F(s)$	Ext.	σ	γ	16	0.50	0.02	0.00	0.00	3.0
	Int.	σ	γ	16	0.50	11.14	5.47	1.28	2.0
Orthogonalization.	Int.	q	u	16	0.11	0.15	0.12	2.0

Key to Table I. Method 1 refers to the method of equations (3) to (10); "As" means that the ellipse was rotated through 45°; Ext. and Int. refer to the exterior-to-exterior and interior-to-interior mappings; I.V. and D.V., to the independent and dependent variables. The number of intervals is N ; R is the (approximate) factor of error reduction per iteration. All errors are tabulated at equal intervals of the independent variable, in the first quadrant. Effort is the approximate number of multiplications involved, times 10^{-3} . (A table look-up is counted as four multiplications; an addition is counted as one-half a multiplication.)

For comparison, we give also the corresponding "exact" values of the different functions involved. With $u(s)$ they are 0.14478, 0.20135, 0.14588 for the exterior, and -0.13232, -0.18625, -0.13632 for the interior case. For $u(q)$ they are 0.12327, 0.19740, 0.16325 for the exterior case and -0.11242, -0.18204, -0.15230 for the interior case. For $u(\sigma)$ they are 0.12327, 0.19740, 0.16325 for the exterior case and -0.18073, -0.16399, -0.09097 for the interior case. For $\gamma(\sigma)$ they are 0.16325, 0.19740, 0.12327 for the exterior case and 0.57534, 0.47729, 0.25524 for the interior case.

where $C(s) = \frac{1}{2}\pi^{-1} \cot \frac{1}{2}s$, $J(s) = \pi^{-1} \operatorname{Im} \{ \ln (1 - s) \}$, and

$$D(s) = -\pi^{-1} \ln (2 \sin \frac{1}{2}s).$$

Here \mathfrak{C} corresponds to conjugacy in the interior ($-\mathfrak{C}$ in the exterior) of the unit circle; \mathfrak{I} to indefinite integration of $v(\sigma)$; and $\mathfrak{D} = -\mathfrak{I}\mathfrak{C}$ is the Dini operator.¹³

Since $v = -F(\sigma - u(\sigma))$, we clearly have

$$(13) \quad u(\sigma) = \pm \mathfrak{C}\{F(\sigma - u(\sigma))\},$$

with the plus sign for the exterior mapping and the minus sign for the interior mapping, provided we specify that $\mathcal{I}u(\sigma) d\sigma = 0$, to remove the ambiguity in $z = g(t)$ which would arise otherwise.

Theodorsen proposed solving (13) by simple iteration. If \mathfrak{C} is a circle with center at 0, since $F(\sigma)$ is a constant, we get the solution $u(\sigma) = 0$ after one iteration, for any initial value. Hence iteration will converge extremely rapidly for nearly circular regions. As shown by Warschawski [13],¹⁴ it will also converge for any star-shaped region.

The integral transform $\mathfrak{C}\{F(\sigma - u(\sigma))\}$ in (12) is divergent, and the Cauchy principal value is taken. In practice, the integral from $\sigma_1 + \epsilon$ to $\sigma_1 + 2\pi - \epsilon$ is usually computed by Simpson's rule or graphically, and the rest of the integral estimated by the formula $F'(0) = (1/2\epsilon)(F(\epsilon) - F(-\epsilon)) + O(\epsilon^2)$ and observing that

$$(14) \quad \int_{-\epsilon}^{\epsilon} F(\sigma) \cot \frac{1}{2}\sigma d\sigma = 2\epsilon F'(0) + O(\epsilon^3).$$

This gives sufficient accuracy for many practical purposes.¹⁵

7. New discretization. For smooth curves, greater accuracy can often be had if *trigonometric interpolation* is used instead of $u = \mathcal{I}C(\sigma - \sigma')v(\sigma') d\sigma'$. With a 3:2 ellipse and $N = 16$, a sixtyfold reduction¹⁶ in the numerical error was obtained in this way for the exterior mapping, while the error was halved for the interior mapping.

The theoretical basis for the improvement seems to come from the easily proved fact that, if $w(z)$ can be extended analytically to a circle of radius $R > 1$,

¹³ The kernels $C(\sigma - \sigma')$, $J(\sigma - \sigma')$, and $D(\sigma - \sigma')$ are well known. For $C(\sigma - \sigma')$, see [11]; for $D(\sigma - \sigma')$, see Dini, *Sull'equazione $\Delta^2\mu = 0$* , Ann. di Mat. II, vol. 5 (1871) pp. 305-345.

¹⁴ See also H. Wittich, Math. Ann. vol. 122 (1950) pp. 6-13.

¹⁵ For a refinement, see I. Naiman, NACA Rep. ARR-307, given restricted circulation as ARR-L4D27 in April, 1944; see also G. Optitz, Zeit. Angew. Math. Mech. vol. 30 (1950) pp. 337-346, and C. Saltzer, Bull. Amer. Math. Soc. vol. 56 (1950) p. 177.

¹⁶ By (14), this corresponds to refining the mesh by a factor of 4, hence to shortening the computation by a factor of 16. We do not know why the interior and exterior mappings should behave so differently. The formulas given were first proposed by I. Naiman, in NACA Rep. ARR-465, given restricted circulation as ARR-L5H18 in September, 1945. For the practical use of Theodorsen's method in airfoil design, see S. Goldstein, J. Aer. Sci. vol. 15 (1948) pp. 189-220, and refs. 8-15 given there.

then trigonometric interpolation to degree n involves errors of $O(R^{-n})$ at most, at each iteration, as contrasted with error $O(\epsilon^3)$ of (14).

Specifically, in the interior-to-interior case, take $N = 2n$ points

$$\sigma_k = k\delta \quad (k = 0, \dots, N - 1)$$

spaced $\delta = 2\pi/N$ radians apart. Set $u_0(\sigma) \equiv 0$, or any better initial guess. From the $u_m(\sigma_k)$, obtain the $u_{m+1}(\sigma_k)$ as follows: denote $F(k\delta - u_m(k\delta))$ by F_{mk} . Set

$$(15) \quad u_{m+1}(k_1\delta) = \sum_{k=0}^{N-1} F_{mk} B(k - k_1),$$

where

$$(15') \quad B(l) = \frac{2}{N} \sum_{h=1}^n \sin hl\delta.$$

Presumably $B(l)$ would be pretabulated. This procedure requires about N^2 multiplications per iteration, like the method of Secs. 2 to 4, but the storage problem is much easier.

When the iteration has converged to $u(\sigma_k) = u_m(\sigma_k) = u_{m+1}(\sigma_k)$, it is convenient to expand

$$v(\sigma_k) = F(k\delta - u(k\sigma)) = \frac{1}{2}a_0 + \sum_{h=1}^n (a_h \cos hk\delta + b_h \sin hk\delta),$$

where

$$\begin{aligned} a_h &= \frac{2}{N} \sum_{k=0}^{N-1} F_{mk} \cos hk\delta, & (h = 1, 2, \dots, n - 1), \\ a_0 &= \frac{2}{N} \sum_{k=0}^{N-1} F_{mk}, & a_n = \frac{1}{N} \sum_{k=0}^{N-1} F_{mk} \cos nk\delta, \\ b_n &= 0, & b_h = \frac{2}{N} \sum_{k=0}^{N-1} F_{mk} \sin hk\delta, & (h = 1, 2, \dots, n - 1). \end{aligned}$$

Then expand $u(\sigma_k) = \sum_{h=1}^n (b_h \cos hk\delta - a_h \sin hk\delta)$.

In case $N = 2n + 1$ is odd, similar formulas hold,¹⁷ except that the formulas for a_n and b_n should be replaced by those for a_h and b_h above, with $h = n$.

The complex polynomial $z = \sum_{h=1}^n c_h t^h$ [$c_h = a_h - ib_h$] also maps the unit circle conformally onto the interior of a curve \mathcal{C}_N which cuts \mathcal{C} at the N points

¹⁷ Dunham Jackson, *The theory of approximation*, Amer. Math. Soc. Colloquium Publications vol. 11 (1930) Chap. IV.

$r_k = \exp F(\theta_k)$, where $\theta_k = k\delta - u(k\delta)$. From this, the correspondence *inside* the curve can be easily calculated, for which purpose the methods of Secs. 2 to 4 are less well adapted.

The preceding method has the disadvantage, as compared with the method of Secs. 2 to 4, that the accurate computation of $F(\theta)$ may be troublesome for a curve given parametrically by $z = z(q)$ and general $\theta_{mk} = k\delta - u_m(k\delta)$. The most systematic procedure is probably to compute $q(\theta_{mk})$ by inverse interpolation in a table of $\theta(q)$, from which $\ln |z(q)|$ can be computed by direct interpolation in a table or by substitution.

8. Free boundary problem. Consider the symmetric flow of a jet J past a (symmetrical) barrier \mathcal{C} of known shape. We assume the flow to be irrotational

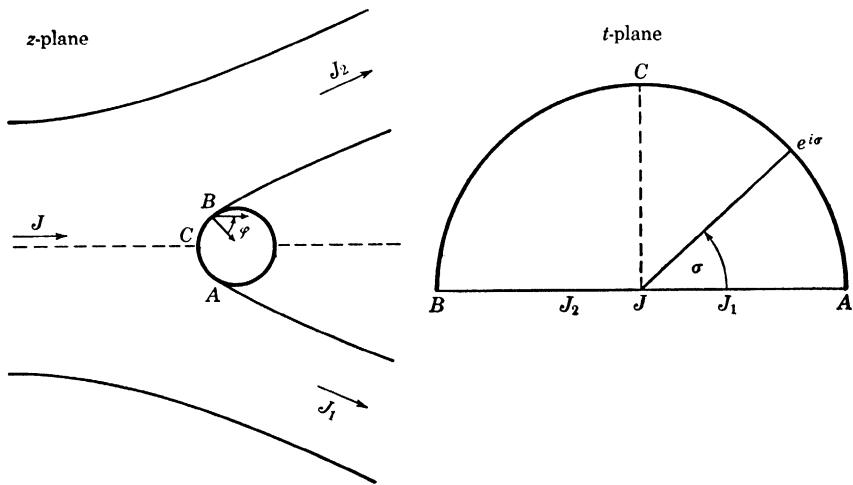

FIG. 2

and volume conserving, so that the complex conjugate ζ of the vector velocity $\vec{\zeta} = \xi - i\eta$ is an analytic function $\zeta(z)$ of position. We also assume that all boundaries of the flow other than \mathcal{C} are "free," *i.e.*, at constant pressure, so that by Bernoulli's theorem and choice of units we can assume

$$(16) \quad |\zeta| = 1, \quad (\text{on the boundary, except along } \mathcal{C}).$$

As in Fig. 2, let the x -axis be the axis of symmetry; we let C be the dividing point, and let A, B denote the points where the flow separates from \mathcal{C} . We let s denote arc length along \mathcal{C} measured from C , and φ the normal on \mathcal{C} away from the flow. We assume that \mathcal{C} has finite curvature everywhere, except perhaps for an angle of $\beta\pi$ radians at C .

By the fundamental theorem of conformal mapping, there is exactly one schlicht transformation $t = f(z)$ which maps the flow onto the unit *semicircle* in the t -plane, so that $f(A) = 1$, $f(C) = i$, and $f(B) = -1$. Under this map, the *free streamline* (which includes three points at infinity) goes into the

diameter, while the wetted portion of the barrier \mathfrak{C} is mapped into the circumference $t = e^{i\sigma}$ [$0 \leq \sigma \leq \pi$]. This is the parametrization of Levi-Civita.¹⁸

General theorems of conformal mapping show that $\zeta = dW/dz$, which vanishes at C unless $\beta = 0$, cannot vanish anywhere else; here W is the complex potential. Further, if we define a new function $\Omega = \theta + i\tau$ by the equations (also of Levi-Civita)

$$(17) \quad \zeta = \left(\frac{1+it}{1-it}\right)^\beta e^{-i\Omega(t)}, \quad \zeta^{-1} = \left(\frac{1-it}{1+it}\right)^\beta e^{i\Omega(t)},$$

we get a function which is still analytic and regular in the interior of the semi-circle, and *continuous on the boundary*, even at C . What is even more important, since $|1+it| = |1-it|$ when t is real, $|\zeta| = e^\tau = 1$ on the real axis. That is, $\Omega(t)$ is *real on the real diameter*.

By Schwarz's principle of reflection, $\Omega(t)$ can therefore be extended to a function analytic in the entire unit circle $|t| < 1$, and continuous on the boundary. We can therefore write

$$(18) \quad \Omega(t) = a_0 + a_1t + a_2t^2 + \dots, \quad (\text{all } a_i \text{ real}),$$

where the radius of convergence of the series (3) is at least unity. On the fixed boundary $t = e^{i\sigma}$, we shall thus have

$$(18') \quad \theta = a_0 + a_1 \cos \sigma + a_2 \cos 2\sigma + \dots,$$

$$(18'') \quad \tau = a_1 \sin \sigma + a_2 \sin 2\sigma + \dots$$

Conversely, any such function $\Omega(t)$ defines the flow of a (possibly self-overlapping) divided jet past a barrier. This is Levi-Civita's main result,¹⁸ somewhat generalized. In the symmetric case, the formulas simplify, since

$$(18a) \quad a_0 = a_2 = a_4 = a_6 = \dots = 0.$$

We now consider the geometric interpretation of θ and τ . Comparing the arguments of the two sides of (17), we see that, on $t = e^{i\sigma}$, θ is the exterior normal to the "smoothed" barrier \mathfrak{C}_1 , obtained from \mathfrak{C} by rotating \widehat{AC} and \widehat{CB} rigidly around C until they become vertical, and that s denotes arc length from C . In the case $\beta = 1$ of a smooth barrier, as in Fig. 2, $\theta = \varphi$.

The differential of arc length is given on $t = e^{i\sigma}$ by

$$(19) \quad ds = |dz| = |\zeta^{-1}| \cdot |dW| = e^{-\tau} \cdot \left| \frac{i+t}{i-t} \right|^\beta \cdot \left| \frac{dW}{dt} \right| \cdot d\sigma.$$

By setting $T = -\frac{1}{2}(t + t^{-1})$, so that T ranges over the upper half plane, we have, on $t = e^{-i\sigma}$,

$$(20) \quad \frac{dT}{dt} = -\sin \sigma, \quad \frac{dW}{dT} = \frac{MT}{1 - \alpha^2 T^2}, \quad (0 < \alpha < 1).$$

¹⁸ T. Levi-Civita, *Scie e leggi di resistenza*, Rend. Circ. Mat. Palermo vol. 23 (1907) pp. 1-37.

The first equation is immediate; the second defines the Schwarz-Christoffel transformation which maps the upper half T -plane conformally onto a symmetrically slit strip, so that $T = \infty$ and $\pm \alpha^{-1}$ (corresponding to the ends of the impinging jet and its symmetric branches) go into the points where the boundary reverses its direction. Further, on $t = e^{i\sigma}$, we have $T = \cos \sigma$, and by trigonometry

$$\left| \frac{t + i}{t - i} \right|^\beta = \left| \frac{1 + \sin \sigma}{1 - \sin \sigma} \right|^{\beta/2} = \left| \cot \left(\frac{\sigma}{2} - \frac{\pi}{4} \right) \right|^\beta.$$

Substituting in (19), we have our final formula

$$(21) \quad s = M \int_{\pi/2}^\sigma e^{-\tau} \frac{F(\sigma) d\sigma}{1 - \alpha^2 \cos^2 \sigma} \quad (0 < \alpha < 1).$$

Here $F(\sigma) = \sin \sigma |\cos \sigma|^{1-\beta} (1 + \sin \sigma)^\beta$ is a *known* function independent of M and α ; it depends only on the vertex angle β . In the case $\beta = 1$ of a smooth barrier, $F(\sigma) = \sin \sigma (1 + \sin \sigma)$. In the case of a *wake* (infinitely wide jet), $\alpha = 0$.

We shall discuss in Sec. 11 the determination of $\Omega(t)$ (and hence of the flow) through the intrinsic equation $\varphi_1 = G(s)$. For many *convex* barriers, it seems more convenient to use instead the curvature-normal equation

$$(22) \quad \kappa = K(\theta)$$

for the smoothed barrier \mathcal{C}_1 . But by (14), except possibly at C ,

$$\kappa = \frac{d\varphi}{ds} = \frac{d\theta}{ds} = \frac{d\theta/d\sigma}{ds/d\sigma} = \frac{1 - \alpha^2 \cos^2 \sigma}{M e^{-\tau} F(\sigma)} \frac{d\theta}{d\sigma}.$$

Hence an equation for symmetrically divided jets past \mathcal{C} is

$$(23) \quad \frac{d\theta}{d\sigma} = M \frac{e^{-\tau} F(\sigma)}{1 - \alpha^2 \cos^2 \sigma} K(\theta) = M \nu(\sigma) e^{-\tau} K(\theta).$$

We shall now discuss the solution of this equation, which involves the parameters M and α .

9. Iterative process: discretization. We can reduce (19) to an integral equation in $\lambda(\sigma) = -d\theta/d\sigma$. In the notation of Sec. 6, $\theta = \Im \lambda$, since $a_0 = 0$. Further, $\tau = \Re \lambda$. Moreover, since $\lambda(-\sigma) = -\lambda(\sigma)$, the Dini transformation reduces on $0 < \sigma < \pi$ to a convergent improper integral

$$\tau(\sigma) = \int_0^\pi D_1(\sigma, \sigma') \lambda(\sigma') d\sigma',$$

where

$$D_1(\sigma, \sigma') = \frac{1}{\pi} \ln \left| \frac{\tan(\sigma/2) + \tan(\sigma'/2)}{\tan(\sigma/2) - \tan(\sigma'/2)} \right| > 0.$$

We also have

$$D(\sigma, \sigma') = D(\sigma - \sigma') + D(\sigma + \sigma'),$$

$D(s)$ being as in Sec. 6.

For any given α , and for M sufficiently small, it is obvious that (23), written symbolically as

$$(23^*) \quad \lambda = -M\nu(\sigma)e^{-D\lambda}K(J\lambda), \quad \left(\nu = \frac{F(\sigma)}{1 - \alpha^2 \cos^2 \sigma} \right),$$

can be solved by *direct iteration*. Since the factor $\nu(\sigma)$ is positive, and the operators $\lambda \rightarrow D\lambda$ and $\lambda \rightarrow J\lambda$ are order-preserving or isotone, while $\tau \rightarrow e^{-\tau}$ is antitone, it is natural to guess that, if $-K(\theta)$ is nonincreasing, *averaged iteration* defined by

$$(23a) \quad \lambda_{r+1} = (1 - \epsilon)\lambda_r + \epsilon M\nu(\sigma)e^{-D\lambda}K(J\lambda),$$

would converge for sufficiently small ϵ and considerably larger M . This guess is supported by actual computation and has been justified theoretically by one of us.¹⁹

An effective discretization of (23*), first proposed by Brodetsky [3], is to use *polynomial approximation* to $\Omega(t)$, much as in Sec. 7. This can be interpreted very simply for any even $N = 2n$ using the *Fourier series* (18'). This gives

$$(24) \quad \lambda(\sigma) = a_1 \sin \sigma + 3a_3 \sin 3\sigma + \dots + (N - 1)a_{N-1} \sin (N - 1)\sigma.$$

We consider functional values at the $2n$ points

$$(24a) \quad \begin{aligned} \sigma_k &= \left(k - \frac{1}{2} \right) \frac{\pi}{N}, & (k = 1, \dots, N), \\ \sigma_{k+1} - \sigma_k &= \frac{\pi}{N} = \delta. \end{aligned}$$

For any selected values of M and α , the product (23*) at the σ_k of (24) is easy to compute. The $\sin h\sigma_k$ and $\cos h\sigma_k$ can be pretabulated, or computed from $\sin \sigma_1, \cos \sigma_1, \sin \delta,$ and $\cos \delta$ using difference equations. The values of $K(J\lambda)$ at the σ_k can be found by interpolation in a table of $K(\theta_1)$ at finely spaced values of θ_1 .

The product (23*), which we denote

$$T\lambda = \lambda_T(\sigma) = M\nu(\sigma)e^{-D\lambda}K(J\lambda),$$

can then be converted to Fourier series by the formulas

$$(25) \quad a'_h = \frac{2}{hN} \sum_{k=1}^N \lambda_T(\sigma_k) \sin h\sigma_k, \quad (h \neq N).$$

¹⁹ E. H. Zarantonello, *A constructive theory for the equations of flows with free boundaries*, unpublished. For small M , convergence under iteration (but not under discretization) was proved by N. Nekrassoff, *Sur le mouvement discontinu à deux dimensions du fluide autour d'un obstacle en forme d'arc de cercle*, Pub. Inst. Poly. Ivan Vosniesiensk (1922).

$$(29) \quad z = g(t) = \alpha t + \alpha_0 + \sum_{k=1}^{\infty} \alpha_k t^{-k}$$

map the exterior of Γ conformally and one-one onto the exterior of \mathfrak{C} . Consider

$$(30) \quad h(t) = \ln g'(t) = c - \sum_{k=2}^{\infty} c_k t^{-k}, \quad (c_k = a_k + ib_k).$$

Since $g'(t) \neq 0$, $h(t)$ is regular and analytic outside Γ . Along \mathfrak{C} ,

$$h(t) = \ln \frac{ds}{d\sigma} + i\gamma,$$

where s measures arc length and $\gamma = \varphi - \sigma$; hence $\tau = \ln ds/d\sigma$ and γ are conjugate on Γ .

We shall try to determine the real function

$$(31) \quad \lambda(\sigma) = \frac{d\gamma}{d\sigma} = \sum_{k=2}^{\infty} k(a_k \cos k\sigma + b_k \sin k\sigma).$$

By the orthogonality of Fourier series, this means

$$(31') \quad \oint \lambda(\sigma) d\sigma = \oint \lambda(\sigma) \cos \sigma d\sigma = \oint \lambda(\sigma) \sin \sigma d\sigma = 0.$$

Conversely, under suitable convergence conditions, any series (31) defines a conformal transformation of the exterior of Γ , unique up to the complex constants c and α_0 in (29) to (30). Moreover, varying these constants simply expands, rotates, and translates the image \mathfrak{C} of Γ .

By direct computation of $\kappa = d\varphi/ds$, writing $\tau = a - \mathfrak{D}\lambda$ and $\gamma = b + \mathfrak{I}\lambda$, as in Sec. 6, one can then prove

LEMMA 3. *Equations (31') and the integral equation*

$$(32) \quad \lambda = -1 + M \cdot K(\sigma + \mathfrak{I}\lambda)e^{-\mathfrak{D}\lambda}, \quad (M = e^2),$$

are necessary and sufficient that $\lambda(\sigma)$ be associated with a conformal transformation of the exterior of Γ onto the exterior of a curve similar to \mathfrak{C} .

Lemma 3 can be simplified by observing that $K(\varphi)$ is not arbitrary. Specifically, since \mathfrak{C} is closed if and only if $\oint dx = \oint dy = 0$, a given $K(\varphi) > 0$ of period 2π expresses the curvature of a closed convex curve if and only if

$$(33) \quad \oint \cos \varphi \frac{d\varphi}{K(\varphi)} = \oint \sin \varphi \frac{d\varphi}{K(\varphi)} = 0;$$

that is, the radius of curvature must be orthogonal to $\cos \varphi$ and $\sin \varphi$. The last two conditions of (31') assert the absence of first-degree terms in $\lambda(\sigma)$. This means similarly that $h(t) = (a - \mathfrak{D}\lambda) + i(b + \mathfrak{I}\lambda)$ has the form (30), hence that $g'(t) = \exp h(t)$ has no term in t^{-1} , hence that $g(t)$ is without logarithmic term. Hence the last two conditions of (31') are also equivalent to asserting that \mathfrak{C} is closed. In summary, we have sketched a proof of

LEMMA 4. *For the conclusion of Lemma 3 to hold, (32) and $\oint \lambda(\sigma) d\sigma = 0$ are necessary and sufficient.*

This fact suggests the following *iteration process* for computing the unknown function $\lambda(\sigma)$. Take as an initial trial function $\lambda_0(\sigma) = 0$, corresponding to the case \mathcal{C} is a circle—or any series (3) corresponding to a better approximation to \mathcal{C} , if one is available. If $\lambda_r(\sigma)$ is the n th trial function, compute successively $\mu_r = K(\sigma + \Im\lambda_r)$, $\tau_r = \mathfrak{D}\lambda_r$, $M_r = 2\pi/\mathcal{J}\mu_r(\sigma) \exp(\tau_r(\sigma)) d\sigma$, and

$$\lambda_{r+1} = -1 + M_r \mu_r \exp \tau_r.$$

By Lemma 3, if this iteration process converges uniformly, then the limit functions will describe a point-to-point boundary correspondence associated with a conformal transformation of the exterior of Γ onto the exterior of \mathcal{C} ; moreover M will be the radius of the circle having the same logarithmic capacity as \mathcal{C} .

A general proof of uniform convergence seems difficult. However, for *nearly circular* regions, the coefficients a_k, b_k converge after n iterations like k^{-n} . Hence, if $a_1 = b_1 = 0$, the *convergence factor should be about one-half*. Unfortunately, there seems to be no reason to expect *this* except in the case

$$K(\varphi + \pi) = K(\varphi)$$

when \mathcal{C} has *central symmetry*, i.e., is invariant under rotation through 180° about its center.

If \mathcal{C} is centrally symmetric, then only even coefficients $k = 2, 4, 6, \dots$ will occur in Fourier series, provided an initial trial function with even coefficients is chosen; hence $a_1 = b_1 = 0$ automatically. In the general case, this restriction could still be achieved by redefining λ_{r+1} as the component of $-1 + M_r \mu_r e^{\tau_r}$ orthogonal to $\cos \sigma$ and $\sin \sigma$; but it is not clear why, with the changed definition, $\lambda_{r+1} = \lambda_r$ should imply that λ_r satisfies (31).

An analogue of the discretization of Sec. 9 can then be used to solve (32) approximately. If iteration converges, the limit trigonometric polynomials will define a conformal transformation of the exterior of Γ onto the exterior of a curve \mathcal{C}_N whose curvature κ and normal direction φ satisfy $\kappa = K(\varphi)$ at N points $z_N(\sigma_k)$.

For the interior mapping, (32) must be replaced by

$$(32a) \quad \lambda(\sigma) = -1 + M \cdot K(\sigma + \Im\lambda) e^{\mathfrak{D}\lambda}.$$

With *central symmetry*, $\lambda(\sigma)$ is unique just as before.

The results for a 3:2 ellipse are tabulated in Table I. As usual, the results for the exterior mapping are more accurate.²¹

²¹ It is to be noticed that, because $\mathcal{J}\lambda d\sigma = 0$, the kernel $\mathfrak{D}(s)$ can be replaced in (32a) by the positive function $\mathfrak{D}^+(s) = \mathfrak{D}(s) + \pi^{-1} \ln 2 = 2\pi^{-1} \ln(\sec s/2)$. Furthermore, if $\lambda^* = \lambda + 1$ is taken as the unknown function, the equations of the problem become

$$\lambda^* = 4Me^{-\mathfrak{D}^+\lambda^*} \kappa(\sigma + \Im\lambda^*), \quad 1 = (2\pi)^{-1} \int_{-\pi}^{\pi} \lambda^* d\sigma.$$

This completes the analogy with the free boundary case ($\nu(\sigma) = 1$). Thus the iteration and discretization theory referred to in footnote 19 is also valid for the fixed boundary case.

12. Formulations using $\varphi = G(s)$. One can also characterize \mathcal{C} up to translation by prescribing the normal direction φ as a function $\varphi = G(s)$ of arc length s . We normalize to the case that \mathcal{C} has length 2π , to simplify formulas.

This characterization can also be interpreted analytically in terms of the function $h(t) = \ln g'(t)$ of (30). We use the notations of Secs. 6 and 11. Necessary and sufficient conditions that $s(\sigma)$ be associated with a schlicht map of the exterior (interior) of the unit circle Γ onto the exterior (interior) of \mathcal{C} are easily shown to be

$$(34) \quad s(\sigma) = M \int_0^\sigma e^{\mp \mathfrak{C}\{G(s(\sigma)) - \sigma\}} d\sigma \quad \text{and} \quad s(2\pi) = 2\pi, \\ 0 = \mathfrak{F}\{G(s(\sigma)) - \sigma\} d\sigma.$$

Here $\gamma(\sigma) = \varphi(\sigma) - \sigma = G(s(\sigma)) - \sigma$ is clearly periodic by our normalization.

The existence, uniqueness, iteration, and discretization theories for the formulation (34) seem to resemble very closely those of Sec. 11 for the formulation in terms of $\kappa = K(\varphi) = G'(G^{-1}(\varphi))$. Thus if \mathcal{C} is symmetric, iteration based on (34) and

$$M_{n+1} = \frac{2\pi}{\int_0^{2\pi} e^{\mp \mathfrak{C}\{G(s_n(\sigma)) - \sigma\}} d\sigma}$$

introduces no odd-order terms. The results of our calculations for the (symmetric) 3:2 ellipse are summarized at the end of Sec. 5; in the exterior case, the results were quite satisfactory.

The geometrical relation $\varphi = G(s)$ has been applied by Villat²⁰ and others, to express the free boundary problem of Sec. 8 in terms of another integral equation. No numerical computations based on it seem to have been published before.

In the terminology of Sec. 8, if $\theta = G(s)$ is the equation of the "smoothed" barrier (so that $\theta = \varphi$ with a smooth barrier), we have

$$(35) \quad s(\sigma) = M \int_0^{\pi/2} e^{-\mathfrak{C}_1 \theta \nu(\sigma)} d\sigma, \quad [\theta = G(s(\sigma)); 0 \leq \sigma \leq \pi],$$

where $\nu(\sigma)$ is as in (23) and $\mathfrak{C}_1 \theta$ represents the conjugate of $\theta = G(s(\sigma))$ on $0 < \sigma < \pi$, extended to $\pi < \sigma < 2\pi$ by $G(s(-\sigma)) = G(s(\sigma))$. For a given barrier, the parameter M again corresponds to the choice of separation point. The parameter problem is analogous to that described in Sec. 10.

For the discretization, we used in the symmetric case trigonometric polynomials of the form

$$(36) \quad \theta = a_1 \cos \sigma + a_3 \cos 3\sigma + \cdots + a_{2n-1} \sin (2n - 1)\sigma.$$

The coefficients a_i in (36) were computed, as in Sec. 7, by trigonometric interpolation at equidistant σ_i ; $\mathfrak{C}_1 \theta$ was then found by replacing cosines by sines. The integral was computed by Simpson's rule by taking twice as many points as in the interpolation.

By direct iterations of (36) and averaged iterations in regard to M (27b), we obtained for a solid 3:2 ellipse, after 14 iterations, the following Fourier coefficients: $a_1 = 1.0965$, $a_2 = -0.0394$, $a_5 = 0.0051$, $a_7 = 0.0004$, $a_9 = 0.0000$, $a_{11} = 0.0000$.

Inspection of the numerical results indicated that the coefficients given in Sec. 10 would have been obtained in about ten more iterations. Our tentative conclusion is that both methods are very accurate in normal cases and that further experiments are needed to decide which is more efficient in a given case. In the case of "ogival" obstacles having piecewise constant curvature, the method of Secs. 8 to 10 is probably shorter.

13. Orthogonalization methods. The function $w(z)$ defined by (2) can also be computed directly, without iteration, by any of various methods of orthogonalization.²² It is well known²³ that $w(z)$ can be uniformly approximated by complex polynomials and that linear independence of harmonic functions on \mathcal{C} implies their linear independence inside \mathcal{C} . Hence $C_k(q) = \text{Re} \{z^k\}$ and $S_k(q) = \text{Im} \{z^k\}$ form a *basis* for functions on \mathcal{C} . An arbitrarily close mean-square approximation $v_n(q) = \sum_{k=0}^n \{a_k C_k(q) + b_k S_k(q)\}$ to $v(q)$, of sufficiently large degree n , therefore exists. Moreover, the *best* mean-square approximation of degree n to $v(q)$ can be computed by the following discretization of the Gram-Schmidt orthogonalization process:²⁴

For simplicity, we denote $C_k(q)$ by $B_{2k}(q)$, $S_k(q)$ by $B_{2k-1}(q)$, and $2n$ by N . We define $O_0 = B_0$, and by recursion

$$(37) \quad O_h(q_j) = B_h(q_j) - \sum_{i=0}^{h-1} \gamma_{h,i} O_i(q_j),$$

where

$$\gamma_{h,i} = \frac{(B_h, O_i)}{(O_i, O_i)}, \quad (i = 0, 1, 2, \dots, h-1),$$

and where inner products are defined by

$$(\varphi, \psi) = \frac{1}{N+1} \sum_{j=0}^N \varphi(q_j) \psi(q_j).$$

The q_j are equally spaced, in view of Lemma 1 of Sec. 4.

²² See G. Szegő, *Math. Zeit.* vol. 9 (1921) pp. 218-270, and Bergman [1]. These authors use intrinsic variables having theoretical interest, but it is not clear that this is important computationally.

²³ J. L. Walsh, *Interpolation and approximation by rational functions in the complex domain*, Amer. Math. Soc. Colloquium Publications vol. 20 (1935) pp. 36, 45.

²⁴ See, for instance, R. Courant and D. Hilbert, *Methoden der mathematischen Physik*, Vol. I, Berlin, 1931, pp. 41-42. The case of an even number of q_j can be treated similarly; cf. Sec. 7.

The computation of the γ_{hi} and the O_h each requires $\frac{1}{3}N^3 + O(N^2)$ operations. If integrals rather than sums were used, the (O_i, O_i) would not be zero, since the $O_h(q)$ are a basis; however, in the discretization, the possible smallness of (O_h, O_h) could give trouble.

The orthogonal projection (best mean-square approximation of degree n) of v is then

$$(38) \quad v_n = \sum_{h=0}^{2n} (v, O_h) \frac{O_h}{(O_h, O_h)},$$

which requires $O(N^2)$ multiplications. In order to find $u_n = -v_n^*$, the negative conjugate of v_n , we must first compute the triangular matrix of coefficients

α_{hk} in the expansion $O_h = \sum_{k=0}^h \alpha_{hk} B_k$. Inverting (37), by induction on h ,

$\alpha_{hh} = 1$ for all h , and $\alpha_{hk} = \sum_{i=k}^h \gamma_{hi} \alpha_{ik}$ for all $k < h$. Hence

$$v_n = \sum_{k=0}^{2n} c_k B_k, \quad \text{where } c_k = \sum_{h=0}^k \frac{(v, O_h)}{(O_h, O_h)} \alpha_{hk}.$$

From this we can easily compute the $u_n(q_j) = - \sum_{k=0}^{2n} c_k B_k^*(q_j)$, since

$$B_{2k}^* = B_{2k-1}$$

and $B_{2k-1}^* = -B_{2k}$. The computation of the α_{hk} requires $N^3/6 + O(N^2)$ multiplications, and the other computations $O(N^2)$ more. Therefore the whole process requires $7N^3/6 + O(N^2)$ multiplications.

The numerical evidence of Table I suggests that, for given N , the preceding orthogonalization method is about as accurate as the methods of Secs. 2 to 6. We also have no theoretical reason to suppose it more or less accurate than these methods.

If this is the case, it should be about as efficient as the preceding methods for analytic curves. For analytic curves, superficial reasoning suggests that all methods discussed should have an accuracy of $O(M^{-N})$ with N points, where $M < 1$. The number I of iterations required to obtain this accuracy will be $O(N)$. Hence the effort required will be $O(IN^2) = O(N^3)$ for iterative methods as well as for orthogonalization methods. Moreover, if \mathfrak{C} is symmetric in both axes, the number of computations required is reduced by a factor of 64 using orthogonalization, and only by a factor of $32 = 4 \cdot 4 \cdot 2$ using the method of Sec. 2. Hence orthogonalization is especially efficient for such curves.

However, for curves of class $C^{(r)}$ [$r < \infty$], the maximum accuracy possible for given N , with $N > r$, is $O(N^{-r})$, and this can be achieved after $I = O(\ln N)$

iterations, so that iterative methods are presumably more efficient than orthogonalization, for sufficiently large N , with nonanalytic curves.

14. Summary of conclusions. Although other methods are possible,²⁵ we think we have reviewed the most practical ones.

Of these, our method (10) and the modified method (10a) of Gerschgorin are the most general and the most amenable to theoretical analysis. For these to be as efficient as the modified Theodorsen method (Sec. 7), the A_{jk} should be recorded on a tape which can be used without manual transcription.

The preceding methods seem about equally efficient for the boundary correspondence with a 3:2 ellipse (see Table I); (10) and (10a) are more accurate, and Theodorsen's method is quicker. Presumably, for regions more nearly circular than this, Theodorsen's method is more efficient, while for less "nearly circular" regions, (10) and (10a) are preferable. The calculation of the correspondence at interior points is probably quicker by Theodorsen's method, in those cases where it is applicable.

The method of Sec. 11 is defective because it involves iteration which converges too slowly, if at all. That of Sec. 12 involves a parameter, and we know of no compensating advantages. Orthogonalization involves $O(N^2)$ operations instead of $O(N)$; thus it is longer, unless \mathcal{C} is symmetric and very smooth.

In all iterative methods, it seems desirable to transform first to the exterior-to-exterior mapping, to obtain best results. We are not clear as to the reason for this.

For the "free boundary" problem, we recommend the procedure of Secs. 8 to 10, largely because we have used it with extensive success. The integral equation of Villat (Sec. 12, end) seems also very promising. It deserves further study, especially in view of its theoretical importance.

Finally, the difficulty of any special case seems empirically to be roughly proportional to the *cube* of the variation in the tangent angle over \mathcal{C} , where in the symmetric case only a representative sector need be considered.

BIBLIOGRAPHY

1. S. Bergman, *Punch-card machine methods applied to the solution of the torsion problem*, Quart. Appl. Math. vol. 5 (1947) pp. 69-81.
2. G. Birkhoff, D. M. Young, and E. H. Zarantonello, *Effective conformal transformation of smooth, simply connected domains*, Proc. Nat. Acad. Sci. U.S.A. vol. 37 (1951) pp. 542-553.
3. S. Brodetsky, *Discontinuous flow past circular and elliptic cylinders*, Proc. Roy. Soc. London Ser. A vol. 102 (1923) pp. 542-553.
4. C. Carathéodory, *Conformal representation*, Cambridge University Press, London, 1932.

²⁵ It is possible to solve the Neumann problem by "relaxation methods," first suggested by H. B. Phillips and N. Wiener, J. Math. Phys. vol. 2 (1923) pp. 105-124; but this would require $O(N^2)$ steps, even when improved (see D. M. Young, *Iterative methods for solving partial differential equations of elliptic type*, Doctoral thesis, Harvard University, 1950). See also L. Kantorovitch, *Sur la représentation conforme*, Rec. Math. (Mat. Sbornik) N.S. vol. 40 (1933) pp. 294-325, for perturbation methods; also A. Rosenblatt, Actas Acad. Nac. Ciencias Lima vol. 6 (1943) pp. 199-219.

5. G. F. Carrier, *On a conformal mapping technique*, Quart. Appl. Math. vol. 5 (1947) pp. 101-104.
6. S. A. Gerschgorin, *Ueber die konforme Abbildung eines einfach zusammenhängenden Bereiches auf den Kreis*, Rec. Math. (Mat. Sbornik) N.S. vol. 40 (1933) pp. 48-58.
7. O. D. Kellogg, *Potential theory*, Springer-Verlag, Berlin, 1933.
8. M. J. Lighthill, *A mathematical method of cascade design*, R. & M. 2104 British ARC (1945) p. 2112.
9. D. M. Young, *On the use of conformal mapping to compute flows with free streamlines*, National Bureau of Standards, Appl. Math. Series 18 (to appear).
10. T. Theodorsen, *Theory of wing sections of arbitrary shape*, NACA Tech. Rep. 411 (1931).
11. ——— and I. Garrick, *General potential theory of arbitrary wing sections*, NACA Tech. Rep. 452 (1934).
12. H. Villat, *Sur la résistance des fluides*, Ann. Ec. Norm. Sup. vol. 28 (1911) pp. 203-240.
13. S. E. Warschawski, *On Theodorsen's method of conformal mapping of nearly circular regions*, Quart. Appl. Math. vol. 3 (1945) pp. 12-28.
14. S. Zaremba, *Sur le calcul numérique des fonctions demandées sans le problème de Dirichlet*, Bull. Int. Acad. Sci. Cracovie vol. 1 (1909) pp. 125-195.

HARVARD UNIVERSITY,
CAMBRIDGE, MASS.

FLOW OF VISCOUS LIQUID THROUGH PIPES AND CHANNELS

BY

J. L. SYNGE

1. Introduction. This paper deals with the numerical solution of certain boundary-value problems which occur in the theory of viscous flow. These problems are easy to formulate mathematically but not easy to solve, unless the boundaries are of certain simple types. The method used below is available for all forms of boundary, yielding bounded solutions (in the mean-square sense) to any desired degree of accuracy. It might be described as a controlled method of finite differences, the control being supplied by the fact that at each stage of the approximation the solution is located on a known hypercircle in function-space.

The method of the hypercircle has been described in previous papers in connection with the theory of elasticity [1] and other problems [2]; it has been given more general form in later communications, recently published [3, 4]. A method, essentially the same, has been developed independently by Diaz and Weinstein [5], who, however, prefer to emphasize the analytical rather than the geometrical aspects of the method and regard it as a generalization of the Rayleigh-Ritz-Trefftz procedures for obtaining upper and lower bounds.

The hypercircle method alone does not give a practical systematic process for drawing the bounds on the solution indefinitely close together. For that, we shall use here "pyramid functions" and associated vector fields, as described briefly in [3] and rather more fully in another paper [6]. The basic idea underlying this procedure, *viz.*, triangulation, has been used by Courant [7].

In view of the scattered nature of the references, all essential formulas are collected in the present paper, so that anyone wishing to use the method in similar problems will have them ready to hand.

It will be seen below that the algebraic equations which have to be solved in order to obtain approximate solutions are very much the same as those one would meet in a finite-difference method. But in the method of finite differences, as ordinarily used, the mere replacement of a differential equation by a difference equation destroys precise assessment of error; only an estimate can be made. In the present method the approximations are controlled throughout by upper and lower bounds in the mean-square sense. Pointwise bounds may also be obtained, but with greater labor, and they will not be considered in the present paper [8].

2. Problems to be discussed. Consider steady, laminar flow parallel to the z -axis for an incompressible viscous fluid. It follows from the Navier-Stokes equations that the velocity w is a function of x, y satisfying the partial differential equation

$$(1) \quad \mu \Delta w = -P,$$

where μ is the viscosity, Δ the Laplacian $\partial^2/\partial x^2 + \partial^2/\partial y^2$, and P the pressure gradient $(-\partial p/\partial z)$, a constant.

Suppose now that the fluid fills a straight pipe with its length parallel to the z -axis. Let A be the cross section of the pipe and B the bounding curve of A . Then, on the usual assumption of no slipping, we have the boundary-value problem

$$(2) \quad \mu \Delta w = -P, \quad (w)_B = 0.$$

This is essentially a Dirichlet problem. If the cross section of the pipe is simply connected, the flow problem coincides mathematically with the torsion problem for a beam with the same cross section as the pipe. The torsional rigidity or stiffness of the beam is closely related to the rate of discharge of the pipe.

To see this connection, we note that the Dirichlet integral of the solution w of (2) is

$$(3) \quad \int (\text{grad } w)^2 dA = - \int w \Delta w dA + \int w \frac{\partial w}{\partial n} dB \\ = \frac{P}{\mu} \int w dA,$$

and so the rate of discharge D is

$$(4) \quad D = \int w dA = \frac{\mu}{P} \int (\text{grad } w)^2 dA.$$

If we define

$$(5) \quad \psi = \frac{1}{2} (x^2 + y^2) + 2 \frac{\mu}{P} w,$$

then

$$(6) \quad \Delta \psi = 0, \quad (\psi)_B = \frac{1}{2} (x^2 + y^2),$$

in which we recognize a statement of the torsion problem. Now, by the Diaz-Weinstein formula [9], the torsional rigidity Γ is given by

$$(7) \quad \Gamma = \int (x^2 + y^2) dA - \int (\text{grad } \psi)^2 dA \\ = \int (x^2 + y^2) dA - \int \left[\left(x + 2\mu P^{-1} \frac{\partial w}{\partial x} \right)^2 + \left(y + 2\mu P^{-1} \frac{\partial w}{\partial y} \right)^2 \right] dA \\ = - \frac{4\mu}{P} \int \left(x \frac{\partial w}{\partial x} + y \frac{\partial w}{\partial y} \right) dA - \left(\frac{2\mu}{P} \right)^2 \int (\text{grad } w)^2 dA \\ = \frac{8\mu}{P} \int w dA - \left(\frac{2\mu}{P} \right)^2 \int (\text{grad } w)^2 dA \\ = \frac{4\mu}{P} \int w dA = \frac{4\mu}{P} D,$$

by (4). Thus, in terms of ψ , the rate of discharge D and the corresponding torsional rigidity Γ are given by

$$(8) \quad D = \frac{P}{4\mu} \Gamma = \left(\frac{P}{4\mu}\right) \left[I - \int (\text{grad } \psi)^2 dA \right],$$

where $I = \int (x^2 + y^2) dA$, the moment of inertia of the cross section.

The rate of dissipation of energy per unit length of pipe is

$$(9) \quad H = \int Pw dA = PD = \mu \int (\text{grad } w)^2 dA,$$

and so both the rate of discharge and the rate of dissipation of energy are proportional to the Dirichlet integral of w .

The second problem with which we shall be concerned is that of currents induced by wind drag. The effect of wind drag in producing ocean currents has been discussed by Munk and Carrier [10]; here we shall consider only a very simple type of problem.

Consider a straight channel of infinite length and any uniform cross section. The channel is filled with water, and a steady wind blows on the surface in the direction of the length of the channel. In reality, waves will be produced, and at the same time a current will be set up in the direction of the wind. In the present idealization, the waves are neglected and the effect of the wind regarded as a shearing force applied to the surface of the channel. There will be no horizontal pressure gradient, and the vertical pressure gradient due to the weight of the water may be canceled out against the body force of gravity.

This provides us with the following mathematical problem: Let Oxy be axes in the plane of the cross section, with Oy directed vertically upward. Let B_1 be the wetted portion of the boundary of the cross section and B_2 the free surface, so that the whole cross section of the fluid is $B = B_1 + B_2$. Let w be the velocity, a function of x and y only, it being assumed that the motion is wholly in the direction of the wind. Then our problem reads:

$$(10) \quad \Delta w = 0, \quad (w)_{B_1} = 0, \quad \left(\frac{\partial w}{\partial n}\right)_{B_2} = \frac{\Sigma}{\mu},$$

where Σ is the shearing force due to the wind. It is a boundary-value problem of mixed Dirichlet-Neumann type.

Both of our two problems [pressure flow as written in (6) and wind drag as written in (10)] are included in the following more general problem:

$$(11) \quad \Delta u = 0, \quad (u)_{B_1} = f, \quad \left(\frac{\partial u}{\partial n}\right)_{B_2} = g,$$

where B_1 and B_2 make up the complete boundary B of the domain and f and g are given functions of position on them.

3. The hypercircle method. Let us think in terms suitable to the problem (11). A point or vector in function-space (F -point or F -vector) corresponds

to a vector field in the domain A of the problem. With indicial notation for the range 1,2, we write this correspondence

$$(12) \quad \mathbf{S} \longleftrightarrow p_i,$$

where \mathbf{S} is the F -point or F -vector and p_i the vector field. The scalar product in function-space is defined by

$$(13) \quad \mathbf{S}' \cdot \mathbf{S}'' = \int p'_i p''_i dA.$$

This gives a positive-definite metric in function-space.

Consider two linear subspaces defined as follows:

$$(14) \quad \begin{array}{l} L', \text{ consisting of } F\text{-points } \mathbf{S}' \longleftrightarrow p'_i = u'_{,i}, (u')_{B_1} = f, \\ L'', \text{ consisting of } F\text{-points } \mathbf{S}'' \longleftrightarrow p''_i, p''_{i,i} = 0, (p''_i n_i)_{B_2} = g, \end{array}$$

the comma denoting partial differentiation and n_i the unit normal to B , drawn outward. Note that for our purposes a linear subspace means a subspace such that, if P and Q are any two F -points in it, then $aP + bQ$ is a point in it also for all a and b satisfying $a + b = 1$.

The definitions (14) mean that L' corresponds to vector fields which are gradients of functions satisfying the boundary condition on B_1 , and L'' to those that are divergence-free and have the normal component g on B_2 .

As regards continuity, we insist that u' be continuous and that the normal component $p''_i n_i$ be continuous across every curve. Any discontinuities consistent with these conditions we call *permissible*.

If \mathbf{S}'_1 and \mathbf{S}'_2 are two F -points in L' , then $\mathbf{T}' = \mathbf{S}'_1 - \mathbf{S}'_2$ is an F -vector lying in L' ; similarly for L'' . Thus F -vectors $\mathbf{T}', \mathbf{T}''$ lying in L', L'' , respectively, have the same specification as $\mathbf{S}', \mathbf{S}''$ in (14), *except that f and g are to be replaced by zero*.

Two facts of basic importance are easy to verify:

(a) The F -point of intersection of L' and L'' is the solution \mathbf{S} , in the sense that it corresponds to the gradient of u where u is the solution of (11).

(b) L' is orthogonal to L'' in the sense that $\mathbf{T}' \cdot \mathbf{T}'' = 0$ for every pair of F -vectors lying in L' and L'' , respectively.

The problem (11) is thus expressed geometrically: To find the intersection of two orthogonal linear subspaces L', L'' .

Our aim is to approximate to the intersection \mathbf{S} . To do this, we start by taking F -points $\mathbf{S}'_0, \mathbf{S}''_0$ in L', L'' , respectively. Then we take a set of F -vectors \mathbf{T}'_ρ ($\rho = 1, 2, \dots, r$) lying in L' and a set \mathbf{T}''_σ ($\sigma = 1, 2, \dots, s$) lying in L'' and so obtain a linear r -space contained in L' and a linear s -space contained in L'' , with the respective parametric equations

$$(15) \quad \mathbf{X} = \mathbf{S}'_0 + \sum_{\rho=1}^r a'_\rho \mathbf{T}'_\rho, \quad \mathbf{X} = \mathbf{S}''_0 + \sum_{\sigma=1}^s a''_\sigma \mathbf{T}''_\sigma.$$

We seek the vertices of these subspaces, *i.e.*, their points of closest approach \mathbf{V}, \mathbf{V}'' . This involves solving the linear equations

$$(16) \quad \sum_{\mu=1}^r a'_\mu \mathbf{T}'_\mu \cdot \mathbf{T}'_\rho + (\mathbf{S}'_0 - \mathbf{S}''_0) \cdot \mathbf{T}'_\rho = 0, \quad (\rho = 1, 2, \dots, r),$$

$$\sum_{\nu=1}^s a''_\nu \mathbf{T}''_\nu \cdot \mathbf{T}''_\sigma - (\mathbf{S}'_0 - \mathbf{S}''_0) \cdot \mathbf{T}''_\sigma = 0, \quad (\sigma = 1, 2, \dots, s),$$

for a', a'' and substituting the solutions in

$$(17) \quad \mathbf{V}' = \mathbf{S}'_0 + \sum_{\rho=1}^r a'_\rho \mathbf{T}'_\rho, \quad \mathbf{V}'' = \mathbf{S}''_0 + \sum_{\sigma=1}^s a''_\sigma \mathbf{T}''_\sigma.$$

Then it can be easily shown that the solution \mathbf{S} is situated on a hypercircle in function-space with the parametric equations

$$(18) \quad \mathbf{S} = \mathbf{C} + R\mathbf{J}, \quad \mathbf{J}^2 = 1, \quad \mathbf{J} \cdot \mathbf{T}'_\rho = 0, \quad \mathbf{J} \cdot \mathbf{T}''_\sigma = 0,$$

($\rho = 1, 2, \dots, r; \sigma = 1, 2, \dots, s$).

The F -vector \mathbf{J} is here arbitrary except for the condition that it shall be a unit vector orthogonal to the $r + s$ selected F -vectors lying in the two linear subspaces. In (18) the center \mathbf{C} of the hypercircle is the F -point

$$(19) \quad \mathbf{C} = \frac{1}{2}(\mathbf{V}' + \mathbf{V}''),$$

and the radius R is given by

$$(20) \quad 4R^2 = (\mathbf{V}' - \mathbf{V}'')^2.$$

The object of the approximation is to make R small; then \mathbf{C} is a good approximation to \mathbf{S} in the sense that its distance from \mathbf{S} is small in terms of the metric of function-space. This means a good approximation in the mean-square sense, as indicated by the relation

$$(21) \quad (\mathbf{S} - \mathbf{C})^2 = R^2.$$

As regards bounds on \mathbf{S}^2 (the Dirichlet integral of the solution), these may be written down in general. But they are simplified for the special problems (6) and (10). For (6) the subspace L'' of (14) contains the origin of function-space, since the part B_2 of the boundary disappears, while in (10) L' contains the origin, since the conditions (14) for L' are satisfied by putting $w = 0$. The results may be summarized as follows:

For pressure flow through a pipe (or equivalently for the torsion problem), considered in the form (6), the rate of discharge D is given by

$$(22) \quad \frac{4\mu D}{P} = I - \mathbf{S}^2,$$

where I is the moment of inertia of the cross section, and it is bounded above and below by the inequalities

$$(23) \quad I - \mathbf{V}'^2 \leq \frac{4\mu D}{P} \leq I - \mathbf{V}''^2,$$

where

$$(24) \quad \mathbf{V}'^2 = \mathbf{S}'_0{}^2 + \sum_{\rho=1}^r a'_\rho \mathbf{S}'_0 \cdot \mathbf{T}'_\rho, \quad \mathbf{V}''^2 = \sum_{\sigma=1}^s a''_\sigma \mathbf{S}'_0 \cdot \mathbf{T}''_\sigma,$$

the a' and a'' being the solutions of the linear equations (16) with \mathbf{S}'_0 deleted. The radius R of the hypercircle is given by $4R^2 = \mathbf{V}'^2 - \mathbf{V}''^2$. As regards \mathbf{S}'_0 , we make the simplest and most natural choice:

$$(25) \quad \mathbf{S}'_0 \longleftrightarrow \text{grad } \frac{1}{2}r^2 = (x, y).$$

Then $\mathbf{S}'_0{}^2 = I$, and the bounds (24) may be written

$$(26) \quad - \sum_{\rho=1}^r a'_\rho \mathbf{S}'_0 \cdot \mathbf{T}'_\rho \leq \frac{4\mu D}{P} \leq I - \sum_{\sigma=1}^s a''_\sigma \mathbf{S}'_0 \cdot \mathbf{T}''_\sigma.$$

For wind drag in a channel, as in (10), we may choose

$$(27) \quad \mathbf{S}'_0 = \mathbf{0}, \quad \mathbf{S}''_0 \longleftrightarrow \text{grad } \frac{y\Sigma}{\mu} = \left(0, \frac{\Sigma}{\mu}\right).$$

The Dirichlet integral of the solution is

$$(28) \quad \mathbf{S}^2 = \int (\text{grad } w)^2 dA,$$

and is bounded by

$$(29) \quad \mathbf{V}'^2 \leq \mathbf{S}^2 \leq \mathbf{V}''^2,$$

where

$$(30) \quad \mathbf{V}'^2 = \sum_{\rho=1}^r a'_\rho \mathbf{S}'_0 \cdot \mathbf{T}'_\rho, \quad \mathbf{V}''^2 = \mathbf{S}''_0{}^2 + \sum_{\sigma=1}^s a''_\sigma \mathbf{S}'_0 \cdot \mathbf{T}''_\sigma,$$

the coefficients being the solutions of (16), with \mathbf{S}'_0 deleted. The radius R of the hypercircle is given by $4R^2 = \mathbf{V}''^2 - \mathbf{V}'^2$.

In this problem the integral (28) is proportional to the rate of dissipation of energy per unit length of channel. However, neither in this problem nor in that of pressure flow is the bounding of the Dirichlet integral likely to be of prime interest for its own sake; it is of interest because the difference of the bounds equals the square of the diameter of the hypercircle, and thus close bounds imply that \mathbf{C} gives a good approximation to the gradient of the solution. It may be more convenient to regard \mathbf{V}' or \mathbf{V}'' as the approximation; the mean-square error is then $(\mathbf{S} - \mathbf{V}')^2$ or $(\mathbf{S} - \mathbf{V}'')^2$, and it cannot exceed $4R^2$.

4. Pyramid functions and associated vector fields. Consider a set of triangles forming a polygon, as in Fig. 1. We may define a function φ over the whole plane as follows:

- $\varphi = 1$ at A , the central point of the polygon,
- $\varphi = 0$ on the boundary of the polygon and outside it,
- φ is a linear function of the coordinates in each of the constituent triangles.

These conditions define φ uniquely, and it is continuous. We shall call it a *pyramid function*.

Let the plane be triangulated in any manner. The triangles may be grouped to form polygons, as in Fig. 1, and each polygon may be taken as the base of a

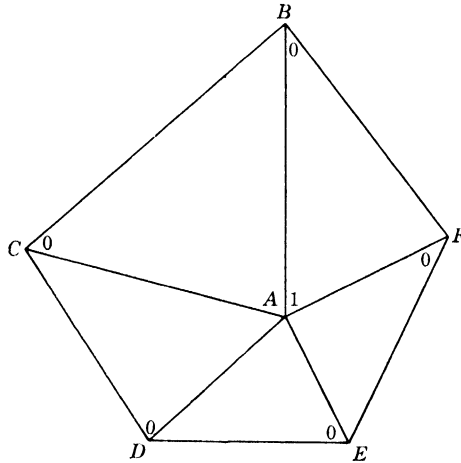

FIG. 1. Base of pyramid function.

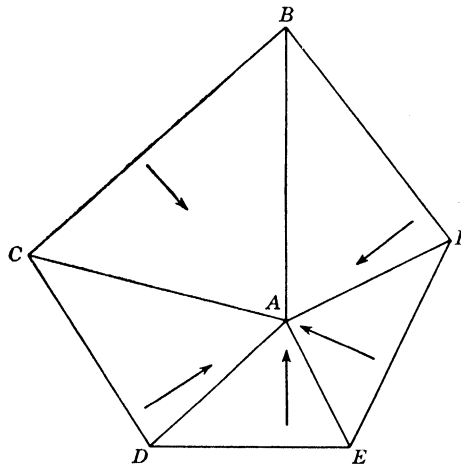

FIG. 2. Pyramid F -vector of the first class.

pyramid function. The bases, of course, overlap. It is easily seen that an arbitrary function, together with its first-order partial derivatives, may be approximated as closely as we please by a linear function of these pyramid functions, provided that the second derivatives of the given function exist and are bounded.

Consider now the gradient of a pyramid function. It vanishes outside the base and is constant in each of the triangles forming the base, the direction being perpendicular to the outer side in each triangle (Fig. 2). In Sec. 3 we

defined an F -point or F -vector by correspondence with a vector field; the F -vector corresponding to the vector field just described we call a *pyramid F -vector of the first class*. We note that it is an F -vector lying in L' (cf. (14) with $f = 0$), provided that the base of the pyramid does not cut the part B_1 of the boundary. The discontinuity in the vector field is permissible.

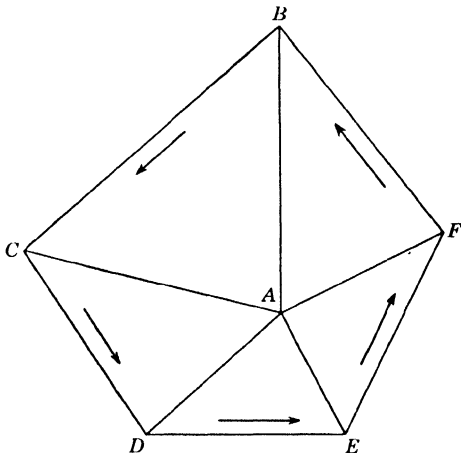

FIG. 3. Pyramid F -vector of the second class.

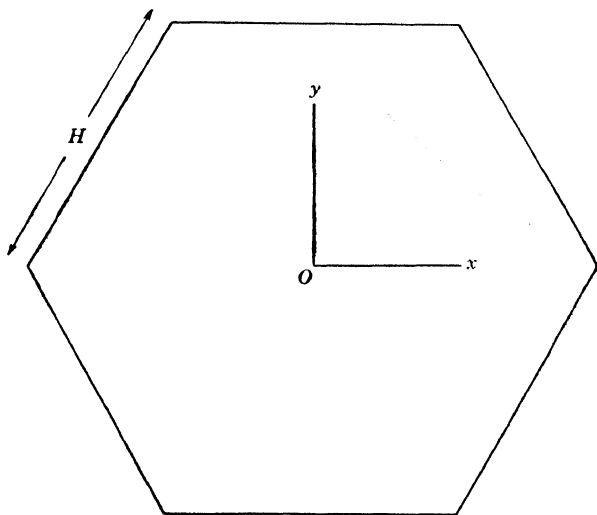

FIG. 4. Pipe of regular hexagonal cross section.

Now rotate the vector field just considered clockwise through a right angle; this gives a field as in Fig. 3. This field has vanishing divergence and continuous normal component across any line; thus it satisfies the conditions for an F -vector lying in L'' (cf. (14) with $g = 0$), provided that the base of the pyramid does not cut B_2 . We call it a *pyramid F -vector of the second class*.

For the F -vectors $\mathbf{T}'_p, \mathbf{T}''_q$ of (15) we shall take pyramid F -vectors of the first

and second classes, respectively, basing them on a triangulation suited to the boundary of the domain of the problem.

5. Pressure flow through a pipe with regular hexagonal cross section. Figure 4 shows the cross section of a pipe, a regular hexagon of side H . This form has been selected to illustrate the use of pyramid functions with the minimum of complexity.

We divide each side of the hexagon into n equal parts and fill the hexagon with equilateral triangles, as shown in Fig. 5 for the case $n = 4$. These triangles

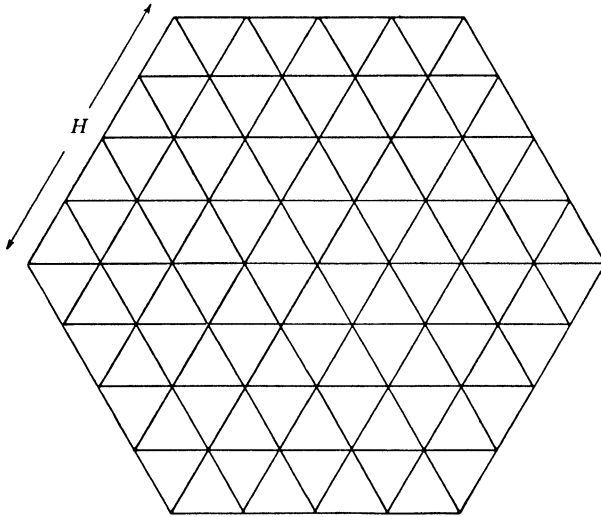

Fig. 5. Triangulation of hexagonal cross section: $n = 4$.

may be grouped into regular hexagons, and each such hexagon taken as the base of a pyramid function. In calculating V' by (17) we use only hexagonal bases included in the cross section; in the case of V'' we use also bases broken by the boundary of the cross section.

By (13) the values of scalar products are as follows:

$$(31) \quad \begin{aligned} \mathbf{T}'_\rho &= 6 \cdot 3^{-1}, \\ \mathbf{T}'_\rho \cdot \mathbf{T}'_\mu &= \begin{cases} -3^{-1} & \text{for } \rho \neq \mu \text{ and overlapping bases,} \\ 0 & \text{for nonoverlapping bases.} \end{cases} \end{aligned}$$

With S'_0 as in (25), we find

$$(32) \quad \mathbf{S}'_0 \cdot \mathbf{T}'_\rho = -3^{\frac{1}{2}} \frac{H^2}{n^2}.$$

Further

$$(33) \quad \begin{aligned} \mathbf{T}''_\sigma &= \begin{cases} 6 \cdot 3^{-1} & \text{for base inside boundary,} \\ 3 \cdot 3^{-1} & \text{for center of base on boundary, but not at a corner.} \end{cases} \\ \mathbf{T}''_\sigma \cdot \mathbf{T}''_\nu &= \begin{cases} -3^{-1} & \text{for } \sigma \neq \nu \text{ and overlapping bases, with overlap} \\ & \text{inside boundary,} \\ -\frac{1}{2} \cdot 3^{-1} & \text{for } \sigma \neq \nu \text{ and centers adjacent on boundary,} \\ 0 & \text{for nonoverlapping bases.} \end{cases} \end{aligned}$$

Also

$$(34) \quad \mathbf{S}'_0 \cdot \mathbf{T}'_0 = \begin{cases} 0 & \text{for base inside boundary,} \\ \frac{xH}{n} & \text{for center with abscissa } x \text{ on the upper edge of the} \\ & \text{boundary (Fig. 4), but not at a corner.} \end{cases}$$

This list of scalar products is not quite complete, but sufficient for our purposes in view of the symmetry of the problem.

We now turn to (16), in which we are to put $\mathbf{S}''_0 = 0$. By (31) and (32) the first line reads

$$(35) \quad 6 \cdot 3^{-1} a'_p - 3^{-1} \sum^{(6)} a'_p - 3^{\frac{1}{2}} \frac{H^2}{n^2} = 0,$$

where $\Sigma^{(6)}$ means the sum for the six neighbors of \mathbf{T}'_p , zero values being inserted if the neighbors are absent (*i.e.*, centers on boundary). We simplify by defining *reduced weights* by

$$(36) \quad b'_p = 2n^2 \frac{a'_p}{H^2};$$

then (35) reads

$$(37) \quad b'_p = \frac{1}{3} \Sigma^{(6)} b'_p + 1.$$

This has the same form as the difference equation we would obtain if we set out to solve a Poisson equation by finite differences, using a mesh of equilateral triangles.

Although we have developed (37) for the specific problem of the regular hexagonal section, it is the basic equation for pressure flow for any section, if we use a mesh of equilateral triangles.

To determine \mathbf{V}' , we have to solve the linear equations (37). This is easy to do by successive approximations, since each equation contains only seven unknowns at most. On account of symmetry, we need consider only one twelfth part of the complete section, as in Fig. 6, using a symmetrical reflection of values in the vertical on the left and in the oblique edge of the part shown. The weights on the upper edge are permanently zero.

Starting then with any weights (or better with the results of a lower approximation), we go over and over the diagram, replacing each weight by the arithmetic mean of its six neighbors, increased by unity. For a high order of approximation (fine mesh) the convergence is rather slow, but it may be accelerated by alternating this "circling process" with a "multiplication process." This consists in reducing the mean error to zero by multiplying all the weights by a "quick-convergence factor" k , the value of which is found to be

$$(38) \quad k = \frac{N}{4\Sigma_1 + 3b'(C)},$$

where $N = 3n^2 - 3n + 1 =$ total number of centers inside the boundary for the complete cross section,

Σ_1 = sum of weights at centers immediately below the upper edge in Fig. 6, but omitting the center on the oblique line,

$b'(C)$ = weight at the center C on the oblique line and immediately inside the boundary of the cross section.

When the values of b'_p have been thus obtained, we get V'^3 from (24), or equivalently a lower bound for the rate of discharge from (26), using (32) and

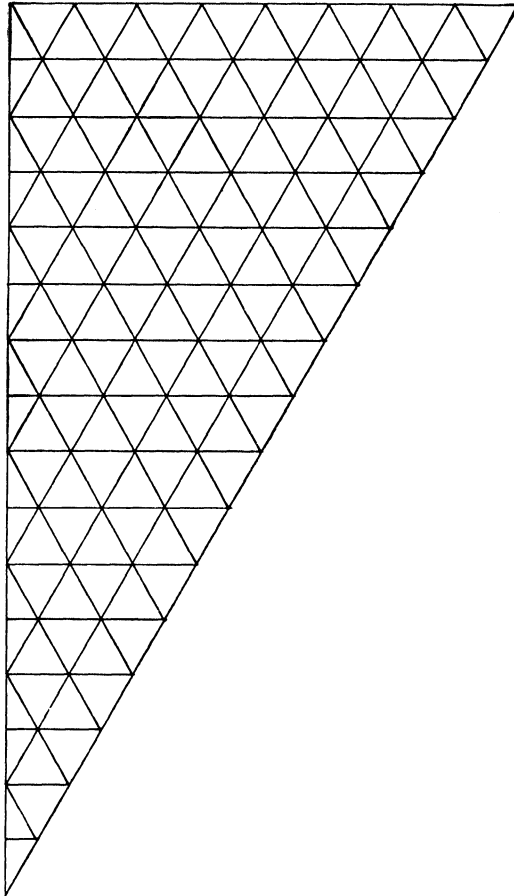

Fig. 6. One twelfth part of complete hexagon: triangulation for $n = 16$. (The vertical boundary on the left is not part of the triangulation.)

(36). This result, stated in a form applicable to both pressure flow and torsion, reads

$$(39) \quad \frac{4\mu D}{P} = \Gamma \geq L = \frac{1}{2} \cdot 3^{\frac{1}{2}} \left(\frac{H}{n}\right)^4 \sum b'_p,$$

this last summation being over the whole cross section, the weights in the eleven twelfths not shown in Fig. 6 being obtained by symmetry.

We have now to consider the calculation of V'' from the second line in (16), and we at once confine our attention to the region shown in Fig. 6. By symmetry, the weights a''_σ are *skew-symmetric* with respect to the lines of symmetry of the section. Hence they vanish on those lines (and thus on the vertical and oblique bounding lines of Fig. 6), and we can at once write in zero values at those centers.

0																																												
27.94		27.58		26.85		25.68		23.96		21.50		17.85		11.92																														
53.22			52.83			51.83			50.00			47.26			43.35			37.82			29.85																							
75.85				74.86				72.81				69.59				64.97				58.57				49.82																				
96.45					95.83					93.93					90.66					85.84					79.19					70.29														
114.68						113.21						110.22						105.57						99.06						90.40														
131.35							130.53							128.07							123.86							117.78							109.60									
145.83								144.07								140.50								135.04								127.52												
159.07									158.14									155.35									150.64									143.91								
170.23										168.31										164.45										158.59														
180.30											179.32											176.37											171.43											
188.34												186.35												182.37																				
195.35													194.35													191.35																		
200.36														198.35																														
204.36															203.36																													
206.36																																												
207.36																																												

Fig. 7. Reduced weights b'_ρ for pressure flow through pipe of hexagonal cross section: approximation $n = 16$. These numbers represent approximately the velocities at the junction points of the triangulation shown in Fig. 6.

We define reduced weights b''_σ by

$$(40) \quad b''_\sigma = 3^{\frac{1}{2}} \cdot 2n \frac{a''_\sigma}{H^2}.$$

Then it is easy to see that the second line of (16) gives

$$(41) \quad b''_\sigma = \frac{1}{8} \Sigma^{(6)} b''_\sigma + m_\sigma,$$

where $\Sigma^{(6)}$ denotes a sum over *six* neighbors of T''_σ . If the center lies on the upper edge in Fig. 6, there are actually only four neighbors (two centered inside

and two on the edge); in such a case it is understood that in applying (41) we are to supplement the actual neighbors by two artificial ones, obtained by reflecting (without change of sign) the neighbors that lie inside the edge. As for m_σ , it is zero if the center of \mathbf{T}'_σ lies inside the boundary, and

$$(42) \quad m_\sigma = \frac{x_\sigma}{\frac{1}{2}H}$$

if the center is on the edge, x_σ being its abscissa.

The values of b''_σ are then found from (41) by the circling process, and in terms of the solution we get from (24)

$$(43) \quad \mathbf{v}''^2 = 3^{\frac{1}{2}} \frac{H^4}{n^2} \sum m_\sigma b''_\sigma,$$

this last summation being along the upper edge in Fig. 6. The moment of inertia of the hexagon is

$$(44) \quad S_0^2 = I = 3^{\frac{1}{2}} \left(\frac{5}{8}\right) H^4 = 1.082532 H^4,$$

and so we get from (26) the following upper bounds in the pressure-flow and torsion problems:

$$(45) \quad \frac{4\mu D}{P} = \Gamma \leq U = 3^{\frac{1}{2}} H^4 \left(\frac{5}{8} - n^{-2} \sum m_\sigma b''_\sigma \right),$$

the summation as before running along the upper edge of Fig. 6.

Figure 7 shows the weights b'_σ for the approximation $n = 16$; these apply to the centers shown in Fig. 6. They are proportional (approximately) to the solution w of (2) and so give us a picture of the distribution of velocity in the pressure flow. Figure 8 shows the weights b''_σ .

The bounds are as follows:

BOUNDS ON $4\mu D/PH^4$ FOR PRESSURE FLOW OR Γ/H^4 FOR TORSION
(Regular Hexagonal Cross Section of Side H)

Approximation, n	Lower bound, L	Upper bound, U
1	0.8660	1.0825
2	0.9382	1.0825
4	1.0034	1.0542
8	1.0264	1.0412
16	1.0331	1.0371

6. Flow under wind drag along a channel with square cross section. The method of the hypercircle may be used to solve the problem of wind drag to any desired degree of accuracy (in the mean-square sense) for any shape of cross section. Two illustrative examples will be considered. First, a square cross section; for this a direct solution is available as a check. Second, an

irregular cross section, viz., a square with two corners removed; for this no direct solution is available.

		6m _σ = 0.750	1.500	2.250	3.000	3.750	4.500	5.250		
0	.670	1.295	1.828	2.212	2.377	2.221	1.572	0		
		.252	.735	1.152	1.453	1.580	1.458	.981	0	
0	.361	.681	.919	1.028	.954	.634	0			
		.128	.367	.553	.649	.615	.411	0		
0	.170	.311	.393	.386	.263	0				
		.057	.158	.224	.233	.163	0			
0	.068	.118	.133	.097	0					
		.021	.056	.071	.055	0				
0	.022	.035	.029	0						
		.006	.015	.014	0					
0	.005	.006	0							
		.001	.002	0						
0	.001	0								
		0	0							
0	0									
		0								
0										

FIG. 8. Reduced weights b''_{σ} for pressure flow through pipe of hexagonal cross section: approximation $n = 16$. The values of $6m_{\sigma}$ are shown at the top.

Up to a certain point the argument is common. In each case we take the stress Σ on the surface to be a constant and write

$$(46) \quad u = \frac{w\mu}{\Sigma},$$

so that our problem, as stated in (10), now reads

$$(47) \quad \Delta u = 0, \quad (u)_{B_1} = 0, \quad \left(\frac{\partial u}{\partial n}\right)_{B_1} = 1.$$

The location of the solution on a hypercircle involves the solution of the linear equations (16). Recalling the specifications in (14), we choose [an obvious modification of (27) on account of the change (46)]

$$(48) \quad S'_0 = 0, \quad S''_0 \longleftrightarrow (0,1).$$

The equations to be solved read

$$(49) \quad \sum_{\mu=1}^r \alpha'_\mu \mathbf{T}'_\mu \cdot \mathbf{T}'_\rho - \mathbf{S}''_0 \cdot \mathbf{T}'_\rho = 0, \quad (\rho = 1, 2, \dots, r),$$

$$\sum_{\nu=1}^s \alpha''_\nu \mathbf{T}''_\nu \cdot \mathbf{T}''_\sigma + \mathbf{S}''_0 \cdot \mathbf{T}''_\sigma = 0, \quad (\sigma = 1, 2, \dots, s).$$

By (14) the specifications of \mathbf{T}'_ρ and \mathbf{T}''_σ are as follows:

$$(50) \quad \begin{aligned} \mathbf{T}'_\rho &\longleftrightarrow p'_i = u'_{,i}, & (u')_{B_1} &= 0; \\ \mathbf{T}''_\sigma &\longleftrightarrow p''_i, & p''_{i,i} &= 0, & (p''_i n_i)_{B_2} &= 0. \end{aligned}$$

What has been said so far applies to any cross section, and although this is true of some of the work that follows, it will be less confusing at this point to think definitely of the square cross section of side s shown in Fig. 9.

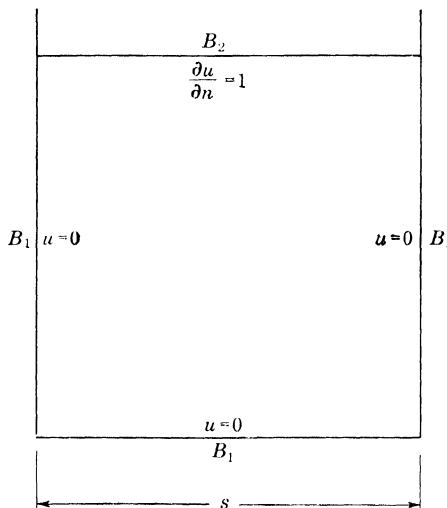

FIG. 9. Channel with square cross section.

A triangulation based on squares is best suited to this cross section, and so we make the triangulation shown in Fig. 10. This may be called the approximation $n = 8$, since the side of the complete square is divided into eight equal parts. On account of symmetry, we can work with one-half of the complete cross section; Fig. 10 shows the right-hand half.

This triangulation provides us with two types of pyramid functions on square bases: small bases of side $2a$ (say) and large bases of side $2 \cdot 2^{\frac{1}{2}}a$. Hence we get two types of pyramid F -vector, as shown in Fig. 11, with the following terminology:

\mathbf{P}', \mathbf{Q}' = square-pyramid F -vectors of the *first* class with small base and large base, respectively,

$\mathbf{P}'', \mathbf{Q}''$ = square-pyramid F -vectors of the *second* class with small base and large base, respectively.

All the F -vectors are normalized by the condition that the generating pyramid function takes the value unity at the center of the base.

To get adequate coverage, we take F -vectors \mathbf{P}' at all the centers of the small squares of Fig. 10, and \mathbf{Q}' at all the corners of squares, omitting those on DCN , in order to satisfy the boundary conditions in (50). Similarly we take \mathbf{P}'' at all centers of small squares and \mathbf{Q}'' at all corners of squares, omitting LN .

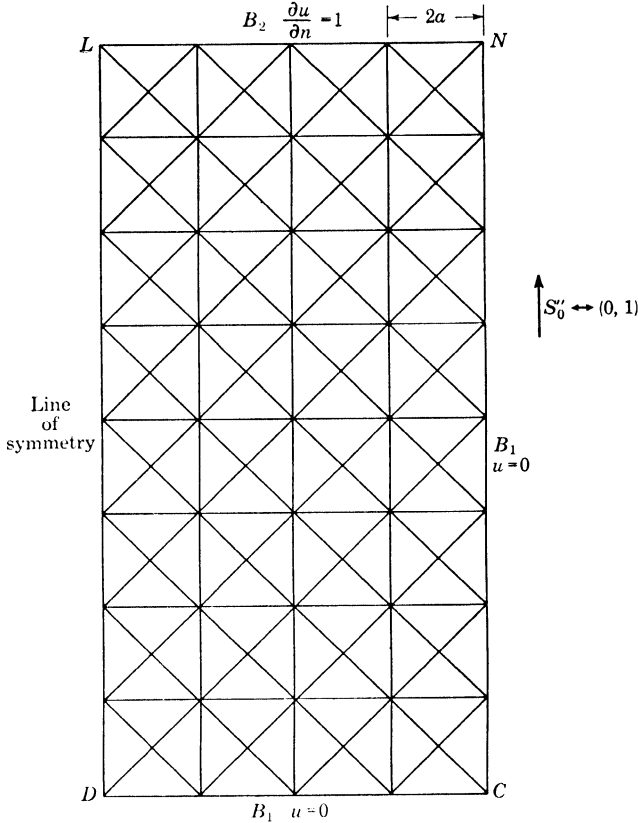

FIG. 10. Channel with square cross section: triangulation in half section for $n = 8$.

We need now the scalar products occurring in (49). Most of these vanish from orthogonality; the survivors are easily calculated, and their values are as follows (B is the complete boundary, of which only one-half is shown in Fig. 10):

$$\begin{aligned}
 & \mathbf{P}' \cdot \mathbf{P}' = \mathbf{P}'' \cdot \mathbf{P}'' = 4, \\
 & \mathbf{Q}' \cdot \mathbf{Q}' = \mathbf{Q}'' \cdot \mathbf{Q}'' = \begin{cases} 4 & \text{if the base lies inside } B, \\ 2 & \text{if the center is on } B \text{ but not at a corner,} \\ 1 & \text{if the center is at a corner,} \end{cases} \\
 (51) \quad & \mathbf{P}' \cdot \mathbf{Q}' = \mathbf{P}'' \cdot \mathbf{Q}'' = -1 \text{ for overlapping bases,} \\
 & \mathbf{S}_0'' \cdot \mathbf{Q}' = 2a \text{ for center of } \mathbf{Q}' \text{ on } B_2 \text{ but not on } B_1, \\
 & \mathbf{S}_0'' \cdot \mathbf{Q}'' = -2a \text{ for center of } \mathbf{Q}'' \text{ on } CN \text{ in Fig. 10, but not at } C \text{ or } N, \\
 & \mathbf{S}_0'' \cdot \mathbf{Q}'' = -a \text{ for center of } \mathbf{Q}'' \text{ at } C.
 \end{aligned}$$

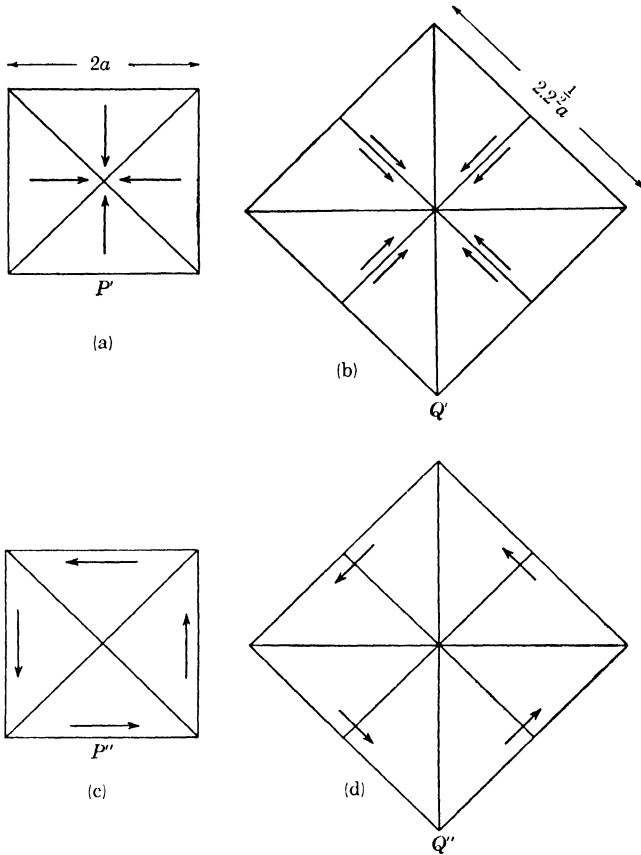

Fig. 11. Square-pyramid F -vectors. (a) First class, small base. (b) First class, large base. (c) Second class, small base. (d) Second class, large base.

If we introduce reduced weights b', b'' defined by

$$(52) \quad b'_p = \frac{a'_p}{a} = \frac{2na'_p}{s}, \quad b''_s = \frac{a''_s}{a} = \frac{2na''_s}{s},$$

the set of equations (49) may be written compactly as follows:

$$(53) \quad \begin{aligned} b'(\mathbf{P}') &= \frac{1}{4} \Sigma^{(4)} b'(\mathbf{Q}'), \\ b'(\mathbf{Q}') &= \frac{1}{4} \Sigma^{(4)} b'(\mathbf{P}') + F, \end{aligned} \quad [b'(\mathbf{Q}') = 0 \text{ on } B_1],$$

$$(54) \quad \begin{aligned} b''(\mathbf{P}'') &= \frac{1}{4} \Sigma^{(4)} b''(\mathbf{Q}''), \\ b''(\mathbf{Q}'') &= \frac{1}{4} \Sigma^{(4)} b''(\mathbf{P}'') + F, \end{aligned} \quad [b''(\mathbf{Q}'') = 0 \text{ on } B_2].$$

Here the summations are in all cases for *four* neighbors. Thus, in the first line of (53), the left-hand side is the reduced weight of any \mathbf{P}' , and the summation on the right is the sum of the reduced weights of the four \mathbf{Q}' neighboring to it, neighbors being joined by oblique lines. The interpretation of the rest of

(53) and (54) is similar. But if the center of \mathbf{Q}' or \mathbf{Q}'' is on B , it will not have four neighbors; then our formulas demand that the full number four be made up by taking symmetrical (fictitious) images in B . At the corner C three images have to be supplied, since there is only one real neighbor.

As for F in the above formulas, it is zero with the following exceptions:

$$(55) \quad \begin{array}{l} \text{In (53), } F = 1 \text{ on } LN, \text{ omitting } N, \\ \text{In (54), } F = 1 \text{ on } CN, \text{ omitting } N. \end{array}$$

Across the line DL the weights b'_σ are symmetric and b''_σ skew-symmetric.

When the reduced weights have been found to satisfy (53) and (54), the vertices are, by (17),

$$(56) \quad \mathbf{V}' = \frac{1}{2}sn^{-1} \sum_{\rho=1}^r b'_\rho \mathbf{T}'_\rho, \quad \mathbf{V}'' = \mathbf{S}_0'' + \frac{1}{2}sn^{-1} \sum_{\sigma=1}^s b''_\sigma \mathbf{T}''_\sigma.$$

By (30) we have (remembering symmetry)

$$(57) \quad \begin{aligned} \mathbf{V}'^2 &= \frac{1}{2}s^2n^{-2} \left[2 \sum_{LN-L} b'(\mathbf{Q}') + b'(L) \right], \\ \mathbf{V}''^2 &= s^2 \left\{ 1 - \frac{1}{2}n^{-2} \left[2 \sum_{NC-C} b''(\mathbf{Q}'') + b''(C) \right] \right\}, \end{aligned}$$

where the first summation is along LN , omitting L , and the second along NC , omitting C . Bounds on \mathbf{S}^2 are then given by

$$(58) \quad \mathbf{V}'^2 \leq \mathbf{S}^2 \leq \mathbf{V}''^2,$$

as in (29); it will be remembered that \mathbf{S}^2 is proportional to the rate of dissipation of energy.

The plan of solving (53) and (54) is to alternate ‘‘circling’’ and ‘‘multiplication.’’ In circling we replace each weight by the appropriate value in terms of the neighbors, as given by these equations. In multiplication we multiply all the weights by a quick-convergence factor which makes the mean error zero. The values of these factors for the approximation n are easily found to be as follows, for (53) and (54), respectively:

$$(59) \quad \begin{aligned} k' &= \frac{2(n-1)}{2(\Sigma_1 + \Sigma_2 - \Sigma_2) + 3b'(I) + b'(J) + b'(L)}, \\ k'' &= \frac{4n}{2(\Sigma_1 + \Sigma_3 - \Sigma_2) + 3b''(C) + 3b''(G) + b''(H) + b''(J) - 5b''(I)}. \end{aligned}$$

The meanings of the terms will be clear on reference to Fig. 12.

For the approximation $n = 8$, with the triangulation shown in Fig. 10, the numerical values of the reduced weights b'_σ and b''_σ are shown in Figs. 13 and 14, respectively. The numbers in Fig. 13 represent approximately the relative values of the velocity at the junction points of the net in Fig. 10. Substitution of these values in (57) and (58) gives the following bounds:

$$(60) \quad 0.2613s^2 = \mathbf{V}'^2 \leq \mathbf{S}^2 \leq \mathbf{V}''^2 = 0.2790s^2.$$

By taking finer and finer nets, the bounds may be drawn as close together as we like.

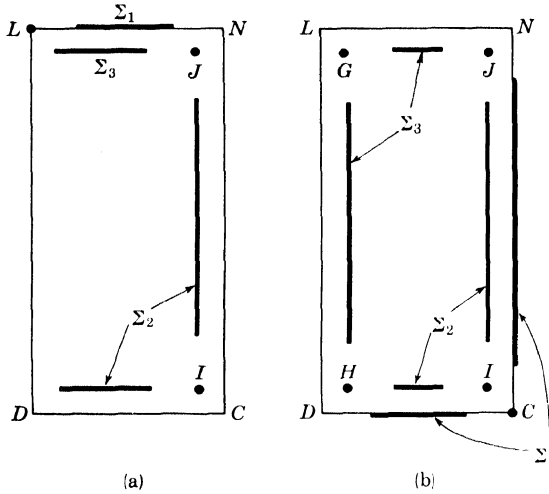

Fig. 12. Channel with square cross section; right-hand half section shown; see equations (59). (a) Notation for quick-convergence factor k' ; Σ_1 consists of Q' centers, Σ_2 and Σ_3 of P' centers. (b) Notation for quick-convergence factor k'' ; Σ_1 consists of Q'' centers, Σ_2 and Σ_3 of P'' centers.

This problem has been worked out as an illustration of the method. It admits a simple exact solution

$$(61) \quad u = 4\pi^{-2}s \sum_{m=0}^{\infty} (2m + 1)^{-2} \operatorname{sech} (2m + 1)\pi \sin (2m + 1) \frac{\pi x}{s} \sinh (2m + 1) \frac{\pi y}{s}$$

the origin being taken at the lower left-hand corner in Fig. 9, with the x -axis horizontal and the y -axis vertical. The Dirichlet integral is

$$(62) \quad \begin{aligned} S^2 &= \iint \left[\left(\frac{\partial u}{\partial x} \right)^2 + \left(\frac{\partial u}{\partial y} \right)^2 \right] dx dy \\ &= 8\pi^{-3}s^2 \sum_{m=0}^{\infty} (2m + 1)^{-3} \tanh (2m + 1)\pi \\ &= 0.27040s^2. \end{aligned}$$

It is interesting (but probably not significant) that this value coincides with the arithmetic mean of the bounds (60) to three decimal places.

7. Flow under wind drag along a channel with irregular cross section. To see the above method in operation for a cross section which does not admit an easy solution, consider the cross section shown in Fig. 15. Here the two lower corners of the square cross section of Fig. 9 have been filled in.

The computations follow the same lines as in Sec. 6. Since the cross section still has symmetry about the central vertical, we can confine our attention to the right-hand half. This we triangulate as in Fig. 16, and take square-pyramid F -vectors of the first class (\mathbf{P}' , \mathbf{Q}') and of the second class (\mathbf{P}'' , \mathbf{Q}'')

L	5.901	5.648	4.841	3.286	0	N
	4.901	4.394	3.288	1.284		
	4.144	3.910	3.176	1.848	0	
	3.387	2.956	2.067	0.752		
	2.841	2.652	2.084	1.160	0	
	2.295	1.971	1.342	0.478		
	1.912	1.774	1.374	0.752	0	
	1.528	1.303	0.878	0.310		
	1.261	1.167	0.898	0.488	0	
	0.994	0.844	0.566	0.199		
	0.804	0.743	0.570	0.309	0	
	0.614	0.521	0.349	0.123		
	0.473	0.437	0.335	0.182	0	
	0.332	0.282	0.189	0.066		
	0.218	0.202	0.155	0.084	0	
	0.105	0.089	0.060	0.021		
D	0	0	0	0	0	C

FIG. 13. Flow through channel with square cross section: approximation $n = 8$. Values of reduced weights b'_p for junction points of Fig. 10. This shows the approximation to the distribution of velocity in the right-hand half of the section.

L	0	0	0	0	0	N
	0.122	0.384	0.719	1.281		
	0	0.486	1.049	1.828	3.296	
	0.348	1.092	2.000	3.312		
	0	0.908	1.924	3.200	4.926	
	0.536	1.658	2.948	4.541		
	0	1.234	2.567	4.103	5.936	
	0.675	2.068	3.593	5.330		
	0	1.466	3.007	4.696	6.586	
	0.772	2.348	4.020	5.842		
	0	1.621	3.298	5.081	7.005	
	0.835	2.530	4.295	6.168		
	0	1.719	3.480	5.320	7.264	
	0.873	2.638	4.458	6.360		
	0	1.773	3.580	5.450	7.404	
	0.891	2.689	4.534	6.449		
D	0	1.790	3.612	5.492	7.449	C

FIG. 14. Flow through channel with square cross section: approximation $n = 8$. Values of reduced weights b''_q for junction points of Fig. 10.

with centers at all the junction points shown, but we attach zero weights to some of them, *viz.*, zero weights to those \mathbf{Q}' with bases cutting B_1 and to those \mathbf{Q}'' with bases cutting B_2 .

We apply (16) with \mathbf{S}'_0 and \mathbf{S}''_0 as in (48) and with reduced weights as in (52). We obtain again precisely (53), *viz.*,

$$\begin{aligned}
 (63) \quad & b'(\mathbf{P}') = \frac{1}{4} \Sigma^{(4)} b'(\mathbf{Q}'), \\
 & b'(\mathbf{Q}') = \frac{1}{4} \Sigma^{(4)} b'(\mathbf{P}') + F, \quad [b'(\mathbf{Q}') = 0 \text{ on } B_1], \\
 & F = 1 \text{ on } LN - N, F = 0 \text{ elsewhere.}
 \end{aligned}$$

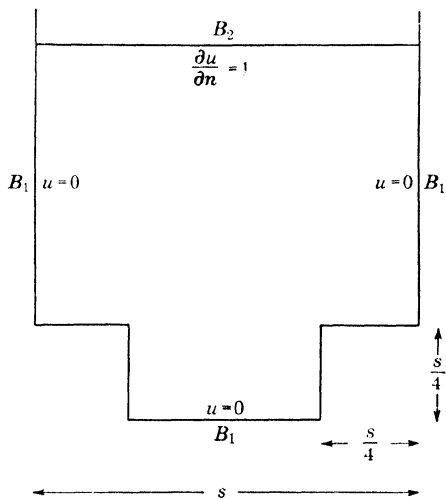

FIG. 15. Channel with irregular cross section.

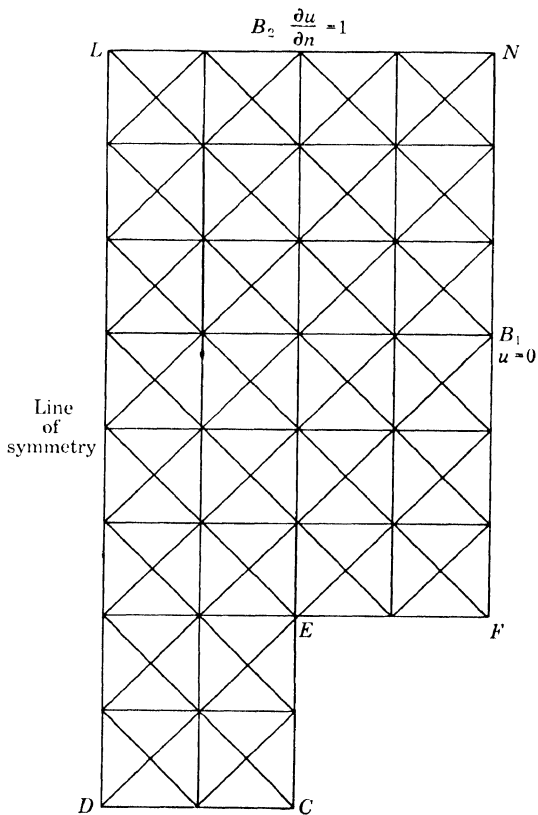

FIG. 16. Channel with irregular cross section: triangulation in half section for $n = 8$.

These summations include always *four* neighbors, with fictitious images supplied where necessary.

The other equations (54) are slightly modified on account of the reentrant corner at E ; they read

$$(64) \quad \begin{aligned} b''(\mathbf{P}'') &= \frac{1}{4} \Sigma^{(4)} b''(\mathbf{Q}''), \\ b''(\mathbf{Q}'') &= \frac{1}{4} \Sigma^{(4)} b''(\mathbf{P}'') + 1 \text{ on } NF - N \text{ and } EC - E, \\ b''(E) &= \frac{1}{3} \Sigma^{(3)} b''(\mathbf{P}'') + \frac{1}{3} \text{ at } E, \\ b''(\mathbf{Q}'') &= \frac{1}{4} \Sigma^{(4)} b''(\mathbf{P}'') \text{ elsewhere.} \end{aligned}$$

The symbol $\Sigma^{(4)}$ means that four neighbors are to be taken, with fictitious neighbors supplied by symmetric reflection where required; $\Sigma^{(3)}$, which occurs

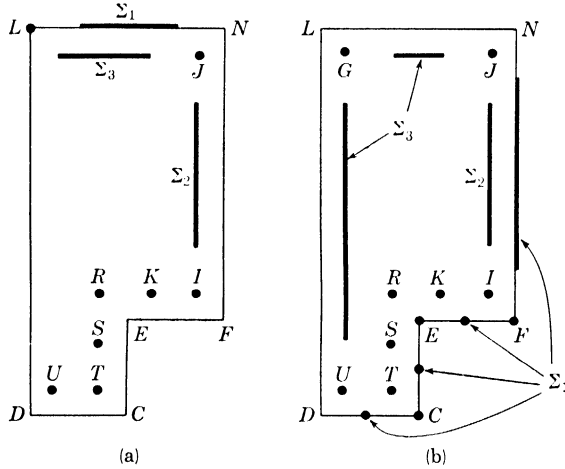

FIG. 17. Channel with irregular cross section: right-hand half section shown; see equations (66). (a) Notation for quick-convergence factor k' ; Σ_1 consists of \mathbf{Q}' centers, Σ_2 and Σ_3 of \mathbf{P}' centers. (b) Notation for quick-convergence factor k'' ; Σ_1 consists of \mathbf{Q}'' centers, Σ_2 and Σ_3 of \mathbf{P}'' centers.

only in connection with the point E , means that we are to take the three \mathbf{P}'' which are neighbors of E .

In terms of the solutions of these equations, we have by (30), since now $\mathbf{S}_0''^2 = s^2 - 2(s/4)^2 = \frac{7}{8}s^2$,

$$(65) \quad \begin{aligned} \mathbf{V}'' &= \frac{1}{2} s^2 n^{-2} \left[2 \sum_{LN-L} b'(\mathbf{Q}') + b'(L) \right], \\ \mathbf{V}'' &= \frac{7}{8} s^2 - \frac{1}{2} s^2 n^{-2} \left[2 \sum_{FN-N-F} b''(\mathbf{Q}'') + b''(F) + b''(E) \right. \\ &\quad \left. + 2 \sum_{EC-E-C} b''(\mathbf{Q}'') + b''(C) \right]. \end{aligned}$$

The equations (63) and (64) are solved by circling and multiplication. For $n = 8$, the quick-convergence factors which make the mean errors zero are as follows, with k' for (63) and k'' for (64):

$$\begin{aligned}
 k' &= \frac{14}{D'} \\
 D' &= 2(\Sigma_1 + \Sigma_2 - \Sigma_3) + b'(L) + b'(J) + b'(R) \\
 &\quad + 2[(b'(K) + b'(S) + b'(U))] + 3[b'(I) + b'(T)], \\
 (66) \quad k'' &= \frac{100}{D''}, \\
 D'' &= 6(\Sigma_1 + \Sigma_3 - \Sigma_2) + 3[b''(J) + b''(U) + b''(E)] \\
 &\quad + 9[b''(G) + b''(F) + b''(C)] \\
 &\quad - 15[b''(I) + b''(T)] - 4[b''(K) + b''(S)] - b''(R).
 \end{aligned}$$

The meanings of the symbols should be clear from Fig. 17. For higher approximations ($n = 16, 32, \dots$) with a finer mesh, the leading numerical

L	5.839	5.590	4.796	3.262	0	N
	4.839	4.341	3.252	1.271		
	4.079	3.849	3.130	1.822	0	
	3.320	2.898	2.028	0.738		
	2.768	2.584	2.031	1.130	0	
	2.216	1.903	1.295	0.461		
	1.822	1.690	1.306	0.714	0	
	1.429	1.214	0.813	0.286		
	1.148	1.056	0.802	0.431	0	
	0.866	0.716	0.464	0.160		
	0.668	0.593	0.414	0.208	0	
	0.469	0.320	0.156	0.052		
	0.340	0.274	0	0	0	F
	0.212	0.093				
	0.135	0.097	0			
	0.058	0.024				
D	0	0	0			C

FIG. 18. Flow through channel with irregular cross section: approximation $n = 8$. Values of reduced weights b'_ρ for junction points of Fig. 16. This shows approximately the distribution of velocity in the right-hand half of the section.

L	0	0	0	0	0	N
	0.120	0.380	0.714	1.275		
	0	0.482	1.040	1.816	3.284	
	0.346	1.082	1.984	3.293		
	0	0.900	1.906	3.174	4.898	
	0.530	1.640	2.917	4.502		
	0	1.218	2.534	4.055	5.881	
	0.666	2.038	3.540	5.260		
	0	1.444	2.956	4.614	6.490	
	0.762	2.308	3.936	5.720		
	0	1.602	3.231	4.944	6.833	
	0.834	2.506	4.173	5.946		
	0	1.732	3.458	5.060	6.946	
	0.892	2.696				
	0	1.834	3.759			
	0.927	2.822				
	0	1.874	3.822			

FIG. 19. Flow through channel with irregular cross section: approximation $n = 8$. Values of reduced weights b''_ρ for junction points of Fig. 16.

factors 14 and 100 in (66) are replaced by $2(n - 1)$ and $4(3n + 1)$, respectively, and the denominators suitably modified.

The numerical solutions are shown in Figs. 18 and 19, the values in Fig. 18 giving us an approximate picture of the distribution of velocity; these solutions may be compared with Fig. 13 to find the effect of blocking the lower corners of the channel. Substitution in (65) gives the values of V'' and V''' , and hence by (29) the bounds

$$(67) \quad 0.2588s^2 = V'' \leq S^2 \leq V''' = 0.2773s^2.$$

As we would expect, these bounds are reduced below those of (60) for the square cross section; the arithmetic mean is now $0.2680s^2$ instead of $0.2701s^2$.

The rate of dissipation of energy per unit length of channel is, by (9) and (46),

$$(68) \quad H = \mu \int (\text{grad } w)^2 dA = \left(\frac{\Sigma^2}{\mu}\right) \int (\text{grad } u)^2 dA = \left(\frac{\Sigma^2}{\mu}\right) S^2,$$

and so we can summarize the results (60) and (67) as follows:

Flow under wind drag: bounds on $\mu H \Sigma^{-2} s^{-2}$, where

μ = viscosity,

H = rate of dissipation of energy per unit length,

Σ = surface stress due to wind.

	Lower Bound	Upper Bound
Square cross section of side s	0.2613	0.2790
Cross section of Fig. 15	0.2588	0.2773

These are for the approximation $n = 8$; a finer mesh would bring the bounds closer together.

BIBLIOGRAPHY

1. W. Prager and J. L. Synge, *Approximations in elasticity based on the concept of function space*, Quart. Appl. Math. vol. 5 (1947) pp. 241-269.
2. J. L. Synge, *The method of the hypercircle in function-space for boundary-value problems*, Proc. Roy. Soc. London Ser. A vol. 191 (1947) pp. 447-467.
3. ———, *Approximations in boundary-value problems by the method of the hypercircle in function-space*, Rendiconti di Matematica e delle sue applicazioni Ser. V vol. 10 pp. 24-44.
4. A. J. McConnell, *The hypercircle method of approximation for a system of partial differential equations of the second order*, Proc. Roy. Irish Acad. Ser. A vol. 54 (1951) pp. 263-290.
5. J. B. Diaz and A. Weinstein, *Schwarz' inequality and the methods of Rayleigh-Ritz and Trefftz*, J. Math. Phys. vol. 26 (1947) pp. 133-136. J. B. Diaz has given a general treatment of the method in a paper *Upper and lower bounds for quadratic functionals*. Proceedings of the symposium on spectral theory and differential problems, Stillwater, Oklahoma (1951) pp. 279-289.
6. J. L. Synge, *Triangulation in the hypercircle method for plane problems*, Proc. Roy. Irish Acad. Ser. A vol. 54 (1952) pp. 341-367.
7. R. Courant, *Variational methods for the solution of problems of equilibrium and vibrations*, Bull. Amer. Math. Soc. vol. 49 (1943) pp. 1-23.
8. The following papers deal with pointwise bounds in boundary-value problems:
H. J. Greenberg, J. Math. Phys. vol. 27 (1948) pp. 161-182.

J. B. Diaz and H. J. Greenberg, *J. Math. Phys.* vol. 27 (1948) pp. 193–201; *Quart. Appl. Math.* vol. 6 (1948) pp. 326–331.

C. G. Maple, *Quart. Appl. Math.* vol. 8 (1950) pp. 213–228.

J. L. Synge, *Proc. Roy. Irish Acad. Ser. A* vol. 53 (1950) pp. 41–64.

———, *Proc. Roy. Soc. London Ser. A* vol. 208 (1951) pp. 170–175.

9. J. B. Diaz and A. Weinstein, *The torsional rigidity and variational methods*, *Amer. J. Math.* vol. 70 (1948) pp. 107–116.

10. W. H. Munk and G. F. Carrier, *The wind-driven circulation in ocean basins of various shapes*, *Tellus* (1950) pp. 158–167.

INSTITUTE FOR FLUID DYNAMICS AND APPLIED MATHEMATICS, UNIVERSITY OF MARYLAND,
COLLEGE PARK, MD.

(ON LEAVE FROM DUBLIN INSTITUTE FOR ADVANCED STUDIES, DUBLIN, IRELAND.)

THE METHOD OF SINGULARITIES IN THE PHYSICAL AND IN THE HODOGRAPH PLANE¹

BY

ALEXANDER WEINSTEIN

1. Introduction. This paper deals partly with incompressible irrotational flows and partly with transonic flows. In the latter case the approximation given by Tricomi's equation will be used.

The method of singularities for incompressible flows is essentially the method of sources and sinks. A special case of this is the method of images, where the sources and sinks are arranged in symmetric fashion. These methods have been developed for plane flows in competition with conformal mapping. It is in the case of axially symmetric flows, however, that the method of sources and sinks plays a dominant role.

About thirty-five years ago W. Arndt [1] observed that the torsion problem for shafts of revolution can be reduced to the theory of an axially symmetric flow of a fictitious incompressible fluid in a space of five dimensions, where again the method of singularities can be used. More recently a generalized axially symmetric potential theory (which will be denoted by the abbreviation GASPT) has been developed by the present author and applied to various problems including Tricomi's equation [2-5].

2. The basic differential equations in GASPT. Let p be a nonnegative real number and let $\varphi(x,y)$ and $\psi(x,y)$ be a pair of associated or conjugate functions defined in the half plane $y \geq 0$ and satisfying the generalized Stokes-Beltrami equations

$$(1) \quad y^p \varphi_x = \psi_y, \quad y^p \varphi_y = -\psi_x.$$

From these follow the differential equations

$$(2) \quad y(\varphi_{xx} + \varphi_{yy}) + p\varphi_y = 0,$$

$$(3) \quad y(\psi_{xx} + \psi_{yy}) - p\psi_y = 0.$$

For $p = 0$, φ and ψ satisfy the Cauchy-Riemann equations. They are both harmonic functions and can be taken as the potential and stream functions for plane flow. For $p = 1, 2, 3, \dots$, φ represents the values taken by an axially symmetric harmonic function (or velocity potential) in the meridian plane x,y of a space of $n = p + 2$ dimensions. The associated function ψ is called a stream function. The object of GASPT is the investigation of the generalized Stokes-Beltrami equations for all integral and nonintegral positive values of p . Regardless of whether p is an integer, we shall still use the same terminology, *i.e.*, potential φ and stream function ψ in the (x,y) meridian plane of a fictitious space of $n = p + 2$ dimensions.

¹ Sponsored by the Office of Naval Research.

It will be seen that there is no difficulty in rewriting for any value of p the familiar and classical formulas of ordinary axially symmetric potential theory. This fact is of special importance in applications. For clarity's sake we shall sometimes write $\varphi\{p\}$ and $\psi\{p\}$ in place of φ and ψ . In this paper we shall use two important principles.

3. The identification principle. As there is a bewildering variety of formulas for most of the functions in GASPT, the following uniqueness theorem is of great importance for the identification of a function: *For $p > 0$, a potential $\varphi\{p\}$ which is regular analytic on a segment of the x -axis is an even function of y and is uniquely determined by its values on this segment. This same uniqueness theorem holds for $\psi\{p\}$ but only for nonintegral values of p .* The theorem is classical for $\varphi\{1\}$ and has been extended by the author for all $\varphi\{p\}$ [2]. In its full generality, as stated above, it has been proved by M. Hyman [6], who has also given a complete discussion of the exceptional cases $\psi\{0\}$, $\psi\{1\}$, $\psi\{2\}$, \dots . Let us note again that $\psi\{0\}$ satisfies the same equation as $\varphi\{0\}$.

4. The correspondence principle in GASPT. We shall make frequent use of the following fundamental identity derived in a previous paper: [2, (48), p. 351]

$$(4) \quad \psi\{p\} = Cy^{p+1}\varphi\{p+2\}.$$

This identity is valid for all $p \geq 0$. Here C denotes an arbitrary constant. This identity permits us to obtain from any stream function $\psi\{p\}$ a potential $\varphi\{p+2\}$, and vice versa. This $\varphi\{p+2\}$, which is defined up to a multiplicative constant, should not be confused with $\varphi\{p\}$, which corresponds to $\psi\{p\}$ by equations (1).

5. The fundamental solution for the potential. The literature of hydrodynamics is replete with the derivation and applications of the flows of an ideal fluid obtained by various combinations of source and sink distributions along an axis parallel to the uniform flow coming from infinity. It is only recently [7] that the method of singularities has been extended for axially symmetric flows to source distributions outside the axis of symmetry. This extension is of interest even for plane flow [8]. We shall restrict ourselves here, however, to the case $p > 0$. The potential due to any distribution of sources and sinks can be derived from the fundamental solutions of (2).

The axis of symmetry, $y = 0$, is a singular line for equation (2). The basic solution for source distributions along this axis is given by the formula

$$(5) \quad \varphi_0\{p\} = (x^2 + y^2)^{-p/2}.$$

The fundamental solution of the same equation (2), with a logarithmic singularity at the point $x = 0$, $y = b > 0$, has *locally* the form

$$(6) \quad \varphi_b\{p\} = \text{const. } y^{-p/2} P_{(p-2)/2} \left(\frac{x^2 + y^2 + b^2}{2by} \right) \log [x^2 + (y - b)^2] + v(x, y),$$

where P denotes the Legendre function of the first kind and $v(x, y)$ is regular

analytic in the neighborhood of the point $x = 0, y = b$. The only condition imposed on $v(x,y)$ is that the right-hand side of equation (6) satisfy the differential equation (2). An equivalent formula was given for $p = \frac{1}{2}$ by Tricomi [9]. His method was not related to GASPT.

The following formulas for a fundamental solution are believed to have been first given by the author [2, (19), (9)]:

$$(7) \quad \varphi_b\{p\} = S_{p-1} \int_0^\pi (x^2 + y^2 + b^2 - 2by \cos \alpha)^{-p/2} \sin^{p-1} \alpha \, d\alpha,$$

where $S_{p-1}^{-1} = \int_0^\pi \sin^{p-1} \alpha \, d\alpha,$

$$(8) \quad \varphi_b\{p\} = \pi S_{p-1} b^{-q} y^{-q} \int_0^\infty e^{-x|t|} J_q(yt) J_q(bt) \, dt,$$

where we put $p = 2q + 1$, and J_q denotes the Bessel function of the first kind. These formulas are closed expressions which are valid *in the large*, *viz.*, in the entire half plane $y \geq 0$. For $y = 0$ each of them yields the same value $(x^2 + b^2)^{-p/2}$. Therefore by the identification principle the two formulas (7) and (8) represent the same potential φ_b .

The formulas (7) and (8) are generalizations of formulas previously known only for $p = 1$ [10, 11]. They represent in this particular case the potential of a ring of sources in ordinary three-dimensional space. For this reason we shall call either of our formulas for φ_b the (generalized) potential of a ring in a space of $p + 2$ dimensions. The formulas (7) and (8) play different roles in GASPT. By using (7), one can show with comparative ease that φ_b possesses a logarithmic singularity at $x = 0, y = b$. This fact would be much more difficult to establish by use of (8). A similar difficulty arises in the determination of the singularity when the method of Fourier transforms is applied to the investigation of the fundamental solution of (2). On the other hand, (8) is much more suitable for the derivation of other basic solutions, as will be seen in Sec. 7.

Making use of Legendre's function of the second kind, Q , we may substitute for (7) or (8) the formula (see [12])

$$(9) \quad \varphi_b\{p\} = S_{p-1} (by)^{-p/2} Q_{(p-2)/2}(1 + 2\epsilon^2),$$

where $\epsilon^2 = [x^2 + (y - b)^2](4by)^{-1}$.

Formula (9) is helpful for determining the coefficient of the logarithmic term of the potential φ_b , as given in (6).

Another fundamental solution in the large of equation (2) has been given in various closed forms in previous papers [2, (59), 5, 12]. This solution is valid for $0 \leq p < 1$. It coincides with $\varphi_b\{p\}$ in its singular part but takes the value zero on the x -axis.

6. The associated stream function ψ_b . The behavior of the stream function ψ_b associated with φ_b requires a detailed discussion. We must distinguish between the cases $b > 0$ and $b = 0$. *The associated stream function ψ_b is*

many-valued for $b > 0$. This fact has been overlooked by Beltrami [11] in his famous memoirs on ordinary axially symmetric potential theory ($p = 1$). A careful search of classical and modern investigations on the Stokes-Beltrami stream function (see, for example, [13, p. 239, 14, p. 367, 15]) reveals that seemingly no mention was made of this fundamental fact (which holds for all $p > 0$) until 1946 [16]. For $b > 0$, ψ_b has a branch point at $x = 0, y = b$. Its behavior at this point is given by the fundamental formula [2, (40)]

$$(10) \quad \lim \psi_b\{p\} = -S_{p-1}\beta,$$

for $x \geq 0, x \rightarrow 0, y \rightarrow b, (b - y)x^{-1} \rightarrow \cot \beta$. A similar formula holds for $x \leq 0$.

For $x \geq 0$ and $x \leq 0$, respectively, we have the two following closed expressions for two branches of ψ_b [2, (26), (27)]:

$$(11) \quad \psi_b\{p\} = -\pi S_{p-1} b^{-q} y^{q+1} \int_0^\infty e^{-xt} J_{q+1}(yt) J_q(bt) dt,$$

$$(12) \quad \psi_b\{p\} = \pi S_{p-1} b^{-q} y^{q+1} \int_0^\infty e^{xt} J_{q+1}(yt) J_q(bt) dt.$$

In case $b = 0$, which means, of course, that the source lies on the x -axis, the stream function associated with $\varphi_0 = (x^2 + y^2)^{-p/2}$ is given for $p > 0$ by the formula

$$(13) \quad \psi_0\{p\} = -p \int_0^\theta \sin^p \alpha d\alpha, \quad [\theta = \arctan (y/x)].$$

For nonintegral values of p , $\psi_0\{p\}$ is defined only for $y \geq 0$. For odd integral values of p , $\psi_0\{p\}$ can be defined as an even function of y for $y \leq 0$, continuous and analytic across the line $y = 0$. If, however, p is an even integer, $\psi_0\{p\}$

has the form $C\theta + \sum_{n=1}^{p/2} C_n \sin 2n\theta$. It is seen that in this case $\psi_0\{p\}$ can also

be defined for $y \leq 0$ but becomes a many-valued function. Summarizing, we may say that only for even integral values of p does the function $\psi_0\{p\}$ behave in a manner similar to the stream function in plane hydrodynamics. These interesting remarks about the behavior of ψ_0 are due to L. E. Payne. Up to now, the remarkable difference between the two classical cases $p = 0$ and $p = 1$ did not apparently give rise to any comment.

7. A list of basic singular solutions. The potential $\varphi_b\{p\}$ of a ring as given by (8) enables us to find a great variety of singular solutions of importance in applications. We shall simply follow the procedure of ordinary potential theory and obtain new solutions by differentiation and integration, prefixing, of course, the appropriate constants. We shall omit all computations and state our formulas, retaining the terminology of ordinary potential theory. Most of these formulas have already been given in previous papers of the author [4, 7].

I. A ring of axial doublets:

$$(14) \quad \varphi_1\{p\} = (by)^{-q} \int_0^\infty e^{-|x|t} J_q(yt) J_{q+1}(bt) t dt, \quad (x \neq 0).$$

II. A ring of transverse doublets:

$$(15) \quad \varphi_2\{p\} = y^{-q}b^{q+1} \int_0^\infty e^{-xt}J_q(yt)J_q(bt)t \, dt, \quad (x > 0).$$

The potential φ_2 is an odd function of x .

III. A uniform disk of sources:

$$(16) \quad \varphi_3\{p\} = y^{-q}b^{q+1} \int_0^\infty e^{-xt}J_q(yt)J_{q+1}(bt)t^{-1} \, dt.$$

IV. A uniform magnetic disk:

$$(17) \quad \varphi_4\{p\} = y^{-q}b^{q+1} \int_0^\infty e^{-xt}J_q(yt)J_{q+1}(bt) \, dt, \quad (x \geq 0).$$

This potential is due to a uniform distribution of transverse doublets over a disk of radius b . It is an odd function of x .

By [2, (62), (67)] we have

$$(18) \quad \lim \varphi_4\{p\} = (\pi - \beta)\pi^{-1},$$

for $x \geq 0$, $x \rightarrow 0$, $y \rightarrow b$, and $(b - y)x^{-1} \rightarrow \cot \beta$.

This list can, of course, be considerably extended. We note also that the corresponding stream functions are easily determined.

8. The method of sources and sinks for incompressible flows. A typical situation considered in the method of sources and sinks for incompressible flows is the superposition of a uniform parallel flow U and of a flow due to a distribution of sources, sinks, and other singularities in a finite region. In other words, solutions of equations (2) and (3) are sought in the form

$$(19) \quad \Phi\{p\} = Ux - \varphi\{p\},$$

$$(20) \quad \Psi\{p\} = U(p + 1)^{-1}y^{p+1} - \psi\{p\}.$$

For the construction of φ and ψ a general source distribution on and off the axis of symmetry can be used. In this way a streamline $\Psi\{p\} = 0$ can be obtained which encloses the singularities. This separation line yields in hydrodynamics the profile of an obstacle of a more or less prescribed shape. This profile will be a closed contour if the total strength of the enclosed sources and sinks is equal to zero. Otherwise, open profiles called half bodies are obtained. These have been investigated by the author [7] and by Breslin [8], A. Van Tuyl [17], and M. A. Sadowsky and E. Sternberg [18]. In the last two papers some of the basic solutions are expressed, for integral values of p , in terms of elliptic integrals.

For $p = 3$, the profile $\Psi = 0$ defines the boundary of a shaft under torsion (see [1, 3, 19]).

9. Generalized electrostatics. It is usually said that the method of sources and sinks is based upon the existence of a stream function Ψ , given by equation (20). However, in the important case of *closed profiles*, which intersect the x -axis, the methods of GASPT permit the reduction of the corresponding flow

to the electrostatics problem for the same profile, but in a space of two more dimensions. This reduction is based upon the fact that both formulas (20) and (4) contain the same factor y^{p+1} . By (4) we may put

$$(21) \quad \psi\{p\} = U(p+1)^{-1}y^{p+1}\varphi\{p+2\}.$$

We have then by (20)

$$(22) \quad \Psi\{p\} = U(p+1)^{-1}y^{p+1}(1 - \varphi\{p+2\}).$$

This equation shows that *to the streamline* $\Psi\{p\} = 0$ *corresponds the level line* $\varphi\{p+2\} = 1$. This statement holds regardless of whether the line $\Psi = 0$ is closed or not. Moreover, if, as assumed in this section, this line is closed, the stream function Ψ tends to $U(p+1)^{-1}y^{p+1}$ at infinity. Therefore, by (22), $\varphi\{p+2\}$ tends to zero for $x^2 + y^2 \rightarrow \infty$. In this way the computation of the stream function $\Psi\{p\}$ is reduced to the determination of the electrostatic potential function $\varphi\{p+2\}$.

The interest of this remark is obvious. It makes the results of electrostatics available for the method of sources and sinks in hydrodynamics, and elasticity, and vice versa. It is true that the formulas of electrostatics are usually given only for the cases $p = 0$ and $p = 1$. But, as already mentioned in Sec. 2, a problem in GASPT which can be solved for any particular value of p is solved without difficulty for all values of p .

To illustrate the procedure, let us begin with a trivial example. Let us consider the plane flow around a circular profile of radius 1 with the center at the origin. The classical procedure for obtaining this flow is the familiar superposition of a uniform flow U and a doublet at the origin. However, by (22) all one must do is find an axially symmetric potential function $\varphi\{2\}$ in four dimensions which assumes the constant value 1 on our circular profile and vanishes at infinity. By (5) this potential is obviously equal to $(x^2 + y^2)^{-1}$. Putting this expression into (22) and noting that $p = 0$, we obtain the standard formula

$$(23) \quad \Psi\{0\} = Uy[1 - (x^2 + y^2)^{-1}].$$

We may say that the doublet in two-dimensional space has been replaced by a source in four dimensions.

Naturally the applications of this method of generalized electrostatics are not confined to the simple example given above. This method has recently been applied to a new problem in elasticity [20]. Quite recently L. E. Payne [21] discussed by this method the axially symmetric flows about a spindle and a lens. Let us take as an example the flow about a spindle.

In order to determine this flow, we must first, according to (22), determine the potential function for a five-dimensional spindle. This is facilitated by the use of dipolar coordinates defined by the transformation

$$x + iy = ic \cot \frac{1}{2}(\xi + i\eta),$$

the range of coordinates being taken as $-\infty < \eta < +\infty$, $0 < \xi \leq \pi$. The boundary of the spindle is defined by $\xi = \xi_0 < \pi$, and the exterior region is given by $0 < \xi < \xi_0$.

Equation (2) with $p = 3$ yields under the dipolar transformation the general solution

$$(24) \quad \varphi\{3\} = (\cosh \eta - \cos \xi)^{\frac{3}{2}} [A_m K_m^{(1)}(\cos \xi) + B_m K_m^{(1)}(-\cos \xi)] (C_m \sin m\eta + D_m \cos m\eta),$$

where K_m denotes the Legendre function commonly called a conal function and the superscript denotes differentiation with respect to the argument. By setting $\varphi\{3\} = 1$ on the boundary of the spindle and prescribing that $\varphi\{3\}$ vanish at infinity, we obtain

$$(25) \quad \varphi\{3\} = 2^{\frac{3}{2}} (\cosh \eta - \cos \xi)^{\frac{3}{2}} \int_0^\infty \frac{K_\alpha^{(1)}(-\cos \xi_0)}{K_\alpha^{(1)}(\cos \xi_0)} K_\alpha^{(1)}(\cos \xi) \cos \alpha \eta \, d\alpha.$$

By use of (22) we have the stream function $\Psi\{1\}$ for the flow about a spindle

$$(26) \quad \Psi\{1\} = \frac{U(c \sin \xi)^2}{2(\cosh \eta - \cos \xi)^2} \left[1 - 2^{\frac{3}{2}} (\cosh \eta - \cos \xi)^{\frac{3}{2}} \int_0^\infty \frac{K_\alpha^{(1)}(-\cos \xi_0)}{K_\alpha^{(1)}(\cos \xi_0)} K_\alpha^{(1)}(\cos \xi) \cos \alpha \eta \, d\alpha \right].$$

In the case of a lens Payne's solution is expressed in terms of Legendre functions of the type discussed by Mehler. It should be noted that for the lens a solution has been recently obtained by M. Shiffman and D. C. Spencer [22], who used an ingenious and difficult procedure involving the method of multisheeted Riemann-Sommerfeld spaces. In contrast to this interesting method, Payne obtains the result in an elementary fashion by a generalization to a space of $2n + 1$ dimensions of the solution for the corresponding electrostatics problem as given by Mehler [23] some eighty years ago.

10. The method of singularities in the hodograph plane and Tricomi's equation. It is sometimes of advantage in the study of plane or axially symmetric flow to consider not the physical plane but the hodograph plane. The hodograph method may be used for incompressible as well as compressible flows. It is not our intention to give here a review of the tremendous amount of work done by the hodograph method. We shall concentrate our attention on the theory of *transonic plane flow of a compressible gas* in the approximation given by Tricomi's equation. The reason for this selection is that a link has been recently established between Tricomi's equation and GASPT [12,4]. This approach allows us for the first time to consider, instead of isolated examples, some flows satisfying prescribed boundary conditions. Let us briefly recapitulate some known facts about compressible, irrotational, isentropic flow of an ideal gas.

As is well known, Chaplygin uses in the main part of his fundamental memoir [24] the independent variables θ and $\tau = q^2/q_m^2$, where θ is the direction of the

velocity and where q and q_m denote the speed and maximum speed, respectively. However, in Part V of his paper, Chaplygin replaces τ by a new variable σ in such a way that σ is positive in the subsonic range and negative in the supersonic range. The values $\sigma = 0$ and $\sigma = +\infty$ correspond to the sonic speed and to the zero speed, respectively. We shall call the plane θ, σ the (modified) hodograph plane. In this plane the stream function $\psi^* = \psi^*(\theta, \sigma)$ satisfies the following equation given by Chaplygin:

$$(27) \quad K(\sigma)\psi_{\theta\theta}^* + \psi_{\sigma\sigma}^* = 0,$$

where K is an extremely complicated function of σ which is positive for $\sigma > 0$ and negative for $\sigma < 0$. For small values of σ we have the following expansion:

$$(28) \quad K(\sigma) = \sigma + a_2\sigma^2 + a_3\sigma^3 + \dots$$

(Let us observe that our σ differs from Chaplygin's definition by a constant factor.) The approximation mentioned in the introduction consists in putting $K(\sigma) = \sigma$. In this way (27) is replaced by Tricomi's equation

$$(29) \quad \sigma\psi_{\theta\theta}^* + \psi_{\sigma\sigma}^* = 0.$$

It is to be expected that this approximation will give particularly good results in the neighborhood of the sonic line $\sigma = 0$.

Tricomi's equation is elliptic in the subsonic range ($\sigma > 0$) and hyperbolic in the supersonic range ($\sigma < 0$). For $\sigma > 0$, we introduce new variables x and y by the formulas

$$(30) \quad x = \theta, \quad y^2 = \frac{4\sigma^3}{9}.$$

In this way we obtain for $\psi^* = \psi^*(x, y)$ the equation

$$(31) \quad 3y(\psi_{xx}^* + \psi_{yy}^*) + \psi_y^* = 0,$$

which can be written in the following form:

$$(32) \quad \frac{\partial}{\partial x} \left(y^{\frac{1}{3}} \frac{\partial \psi^*}{\partial x} \right) + \frac{\partial}{\partial y} \left(y^{\frac{1}{3}} \frac{\partial \psi^*}{\partial y} \right) = 0.$$

We notice by comparison of (31) with (2) that the *stream function* ψ^* considered as a function of x and y for $y \geq 0$ satisfies the equation of an *axially symmetric potential* $\varphi\{\frac{1}{3}\}$ in the meridian plane x, y of a fictitious space of $p + 2 = 2\frac{1}{3}$ dimensions. This allows us to use the results of GASPT. The xy -plane is not to be confused with the physical plane of the gas flow. It is the meridian plane of GASPT and will be used as another modified hodograph plane.

It should be noted that a uniform flow in the physical plane is represented by a single point in the (x, y) hodograph plane. All streamlines $\psi^* = \text{constant}$ pass through this point. It will be, therefore, a singular point for this function. This point will be, generally speaking, a subsonic point, say $x = 0, y = b$,

where b is positive. Until the introduction of GASPT, investigations on transonic flow based on Tricomi's equation were restricted mainly to the case of free-stream Mach number one [25]. The reason for this lies in the fact that it is much easier to find solutions with singularities on the sonic line, because the sonic line corresponds to the axis of symmetry in GASPT.

11. The flow about a wedge. As a main application, let us consider the transonic flow around a rectilinear wedge located symmetrically in a rectilinear channel. It will suffice to consider the upper portion of the flow. Let us denote the axis of symmetry by L , the wedge of inclination α by W , the upper wall by U , and the sonic line by S (Fig. 1). The application of the hodograph method is, as always, based on certain assumptions which have to be verified

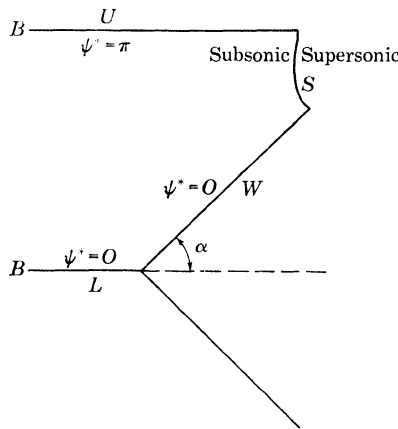

FIG. 1. Physical plane.

in the physical plane. In our case we assume that the free flow is coming from the left at a subsonic horizontal velocity and that the speed on U increases to the sonic velocity. On L it is assumed that the speed decreases and reaches the value zero at the point 0 . Later, along W , the speed increases to the sonic speed.

In view of our assumptions we have in the hodograph plane a vertical half strip (Fig. 2). We use the same notations L , U , W , and S for corresponding lines. The point B with coordinates $\theta = 0$, $\sigma = 2b^3/3$ represents the velocity at infinity upstream. The boundary conditions are the following: $\psi^* = 0$ on L and on W ; $\psi^* = \pi$ on U . (We have put the flux equal to π .)

To obtain the corresponding stream function ψ^* , we shall make use of the potential $\varphi_4\{\frac{1}{3}\}$ given by formula (17). This potential is in transonic flow a stream function which we shall call ψ^* . According to the results given in [2, p. 352], ψ^* has the property that all streamlines $\psi^* = C$, $-\pi < C \leq \pi$, emerge from the singular point, a fact which shows that ψ^* possesses the

required singularity. To satisfy the condition on W , we use the method of images. We take an infinite sequence of magnetic disks (17) with centers at $x = 2n\alpha$, $n = 0, \pm 1, \pm 2, \dots$, and add the values of the corresponding potentials. In this way we obtain an explicit formula for $\psi^*(x,y)$. Reintro-

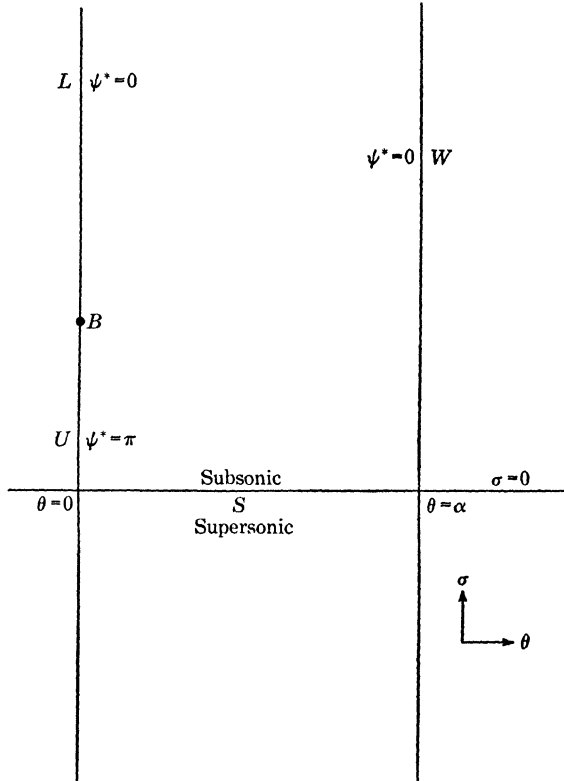

FIG. 2. Hodograph plane.

ducing in place of x and y Chaplygin's variables θ and σ by (30), we obtain finally the following expression:

$$(33) \quad \psi^*(\theta, \sigma) = \pi \left(\frac{2}{3}\right) \sigma^{\frac{1}{3}} b \int_0^\infty \frac{\sinh(\alpha - \theta)t}{\sinh \alpha t} J_{-1}\left(\frac{2}{3} \sigma^{\frac{2}{3}} t\right) J_1\left(\frac{2}{3} b^{\frac{2}{3}} t\right) dt,$$

which is valid for the subsonic range $\sigma \geq 0$.

12. Concluding remarks. Tricomi's equation is, for $\sigma < 0$, of hyperbolic type and can be written as an Euler-Poisson equation. The limitations of the present paper do not allow us to go into this phase of the theory. It will suffice to note that the methods of GASPT are of interest in the study of such hyperbolic equations. In particular, our fundamental solution (7) or (8) can be extended in closed form to the entire hyperbolic half plane $\sigma \leq 0$ [5].

Let us note that subsequent to [2] the fundamental solution of (29) has been investigated in the large by G. F. Carrier and F. E. Ehlers [26], S. Tomotika

and K. Tomada [27], P. Germain and R. Bader [28], T. von Kármán and J. Fabri [29], and P. Germain [30]. It should be noted that formula (21) of [26] yields a solution which is discontinuous along the line $y = b$.

In a paper by J. D. Cole [31] which deals with the flow about a wedge in a free stream, the contents of [4] are reproduced with slight modification.

(*Note added in proof:* More recently Cole [32] reconsiders the problem of the continuation of the solution of Tricomi's equation into the half plane $\sigma \leq 0$, previously discussed in [5] and [30]. For further results and literature see P. Germain and R. Bader [33].)

BIBLIOGRAPHY

1. W. Arndt, *Die Torsion von Wellen*, Thesis, Göttingen, 1916.
2. A. Weinstein, *Discontinuous integrals and generalized potential theory*, Trans. Amer. Math. Soc. vol. 63 (1948) pp. 342-354.
3. ———, *On the torsion of shafts of revolution*, Proc. VIIth Int. Congr. Appl. Mech. vol. 1 (1948) pp. 108-119.
4. ———, *Transonic flow and generalized axially symmetric potential theory*, Proc. Aeroballistic Research Symposia, Naval Ordnance Laboratory (1949) pp. 73-82.
5. ———, *On Tricomi's equation and generalized axially symmetric potential theory*, Bull. Acad. Roy. Belgique vol. 37 (1951) pp. 348-358.
6. M. Hyman, *Preliminary reports*, Bull. Amer. Math. Soc. vol. 54 (1948) p. 1065; vol. 55 (1949) pp. 284-285.
7. A. Weinstein, *On axially symmetric flows*, Quart. Appl. Math. vol. 5 (1948) pp. 429-444.
8. J. P. Breslin, *Two-dimensional flow about half bodies between parallel walls*, Thesis, University of Maryland, 1951.
9. F. Tricomi, *Sulle equazioni lineari alle derivate parziali di second ordine, di tipo misto*, Atti Accad. Naz. Lincei (1923); translation: Brown University (1948).
10. O. D. Kellogg, *Foundations of potential theory*, Springer-Verlag, Berlin, 1929, p. 58.
11. E. Beltrami, *Opere matematiche*, Vol. 3, U. Hoepli, Milan, 1911, pp. 349-382.
12. A. Weinstein, *On generalized potential theory and the equations of Darboux-Tricomi*, Bull. Amer. Math. Soc. vol. 55 (1949) p. 520.
13. H. Lamb, *Hydrodynamics*, Dover Publications, Inc., New York, 6th ed., 1945, p. 239.
14. A. G. Webster, *Partial differential equations of mathematical physics*, Hafner Publishing Company, New York, 1947, p. 367.
15. M. Marden, *Axisymmetric harmonic vectors*, Amer. J. Math. vol. 67 (1945) pp. 109-122.
16. A. Weinstein, *On Stokes stream function and Weber's discontinuous integral*, Bull. Amer. Math. Soc. vol. 52 (1946) p. 240.
17. A. Van Tuyl, *On the axially symmetric flow around a new family of half bodies*, Quart. Appl. Math. vol. 7 (1950) pp. 399-409.
18. M. A. Sadowsky and E. Sternberg, *Elliptic integral representation of axially symmetric flows*, Quart. Appl. Math. vol. 8 (1950) pp. 113-126.
19. H. Poritzky, *Stress fields of axially symmetric shafts in torsion and related fields*, *Elasticity*, Proc. Symposia Appl. Math., Vol. 3, McGraw-Hill Book Company, Inc., New York, 1950, pp. 163-186.
20. A. Weinstein, *On cracks and dislocations in shafts under torsion*, Quart. Appl. Math. vol. 10 (1952) pp. 77-81.
21. L. E. Payne, *On axially symmetric flow and the method of generalized electrostatics*, Quart. Appl. Math. vol. 10 (1952) pp. 197-204. See also Bull. Amer. Math. Soc. vol. 58 (1952) p. 47.

22. M. Shiffman and D. C. Spencer, *The flow of an ideal incompressible fluid about a lens*, Quart. Appl. Math. vol. 5 (1947) pp. 270-288.

23. F. G. Mehler, *Ueber die Vertheilung der statischen Elektrizität in einem von zwei Kugelkalotten begrenzten Körper*, J. Reine Angew. Math. vol. 68 (1868) pp. 134-150.

24. S. Chaplygin, *Gas jets*, Scientific Memoirs, Moscow University, 1902. Translation: NACA Tech. Mem. 1063.

25. G. Guderley and H. Yoshihara, *The flow over a wedge profile at Mach number one*, AF Tech. Rep. 5783, U.S. Air Force Air Materiel Command (1949) pp. 1-37.

26. G. F. Carrier and F. E. Ehlers, *On singular solutions of the Tricomi equation*, Quart. Appl. Math. vol. 6 (1948) pp. 331-334.

27. S. Tomotika and K. Tomada, *Studies on two-dimensional transonic flows of a compressible fluid*, II, Quart. Appl. Math. vol. 8 (1950) pp. 127-136.

28. P. Germain, *Nouvelles solutions de l'équation de Tricomi*, C. R. Acad. Sci. Paris vol. 231 (1950) pp. 1116-1118.

——— and R. Bader, *Application de la solution fondamentale à certain problèmes relatifs à l'équation de Tricomi*. C. R. Acad. Sci. Paris vol. 231 (1950) pp. 1203-1205.

29. T. von Kármán and J. Fabri, *Écoulement transsonique à deux dimensions le long d'une paroi ondulie*, C. R. Acad. Sci. Paris vol. 232 (1950) pp. 1271-1274.

30. P. Germain, *Solutions élémentaires des équations régissant les écoulements des fluides compressibles*, C. R. Acad. Sci. Paris vol. 234 (1952) pp. 1248-1250.

31. J. D. Cole, *Drag of a finite wedge at high subsonic speeds*, J. Math. Phys. vol. 30 (1951) pp. 79-93.

32. ——— *Note on the fundamental solution of $wy_{vv} + y_{ww} = 0$* , Z. Angew. Math. Phys. vol. 3 (1952) pp. 286-297.

33. P. Germain and R. Bader, *Sur quelques problèmes relatifs à l'équation de type mixte de Tricomi*, O.N.E.R.A. No. 54 (1952).

INSTITUTE FOR FLUID DYNAMICS AND APPLIED MATHEMATICS, UNIVERSITY OF MARYLAND,
COLLEGE PARK, MD.

INDEX

A

Actuator disk, 116
 Advancing wave, 41
 Ahlfors, L. V., 120*n.*
 Airy, Sir G., 78
 Angular distortion function, 119, 124
 Antitone operator, 131
 Arndt, W., 167, 177
 Axial-loss factor, 114, 115
 Axisymmetric tensors, 7–10
 Axisymmetric turbulence, 7–10
 Axisymmetric vectors, 9
 Axisymmetry, 8

B

Bader, R., 177, 178
 Bäcklund transformation, 63
 Barrier, 133
 convex, 130
 cylindrical, 76
 flat, 132
 inclined, 76
 semi-infinite dock, 75
 smooth, 129, 130
 submerged, plane, 75
 plane semi-infinite, 79–84
 semi-infinite, 75
 surface, 84
 symmetric, 128, 132
 smooth solid, 132
 vertical, finite length, 84
 plane, 76
 Barycentric kinetic energy, 89
 Barycentric substantial time derivative, 88
 Barycentric velocity, 89
 Batchelor, G. K., 7, 9, 17, 27
 Beltrami, E., 177
 Bergman, S., 137*n.*, 139
 Bernoulli equation, 111, 112
 Bernoulli function, 61
 Bernoulli theorem, 128
 Bers, L., 72
 Bessel functions, 64, 169
 Betz, A., 117*n.*
 Birkhoff, G., 117, 120*n.*, 128–132, 139
 Blade-design problem, 116
 Bochner, S., 75, 85

Boggio, T., 75, 85
 Boundary, fixed, case, 117, 135*n.*
 analogue for, 133–136
 free, case, 117, 128–130, 135*n.*, 136, 139
 Boundary conditions, 29, 31, 34, 37–39,
 47, 52, 75, 78, 79, 81, 156, 175
 Boundary-value problems, 75
 in viscous flow, 141–164
 Breslin, J. P., 171, 177
 Brinkley, S. R., Jr., 104–106, 108
 Brodetsky, S., 131, 139
 Buell, E., 85
 Burgers, J. M., 101, 108
 Busemann, A., 29, 39

C

Carathéodory, C., 139
 Carrier, G. F., 55, 60, 119, 121, 140, 143, 165,
 176, 178
 Casimir, H. G. B., 98
 Cauchy's integral formula, 119
 Cauchy's integral theorem, 122
 Cauchy-Riemann equations, 167
 Center-of-gravity motion, 88, 90, 93
 Chandrasekhar, S., 1, 9, 10, 13, 16, 17, 24,
 26, 27
 Channel, infinite depth, 77–78
 irregular cross section, 159–164
 square cross section, 153–159
 uniform finite depth, 77–78
 Channels and pipes, flow of viscous liquid
 through, 141–164
 Chaplygin, S., 58, 173, 178
 Chaplygin's equation, 30*n.*, 174
 Chaplygin's variables, 176
 Chapman-Enskog model, 90
 Chemical affinity, 94, 98
 De Donder, 91
 Chemical drag coefficient, 92
 Chemical reaction rate, 89
 Cherry, T. M., 61*n.*
 Circling and multiplication processes, 150,
 153, 158, 162
 Circular regions, 120
 nearly, 120, 123, 124, 126, 135, 139
 Circulation, limiting value of, 111
 Circulation function, nondimensional, 111

- Circulation theorems, Kelvin and Helmholtz, 11
 Closed system, 96
 Cole, J. D., 177, 178
 Compressible flow, 133
 Compression wavefront, 42
 Compressive flow, 48
 Conformal mapping, 117–139, 167
 fundamental theorem of, 128
 methods, Birkhoff, Young, Zarantonello, 128–132, 139
 Carrier's, 123, 124
 Gerschgarin's, 117–124, 139
 numerical, 117–139
 Theodorsen's (*see* Theodorsen's conformal mapping method)
 Continuity assumptions, 48–49
 Continuity equations, 3, 13, 105
 Contour, distorted, 57
 Convex regions, 120, 133
 Cooper, J. L. B., 75, 85
 Cornu spiral, 61
 Correlation functions, self-preserving, 19, 21
 Correlation tensors, 1, 3
 Correlations, double, 11
 longitudinal, 12
 triple, 3, 4, 11
 Courant, R., 73, 118*n.*, 137*n.*, 141, 164
 Crigler, J. L., 116
 Currents, induced by wind drag, 143
 ocean, 143
 Cusped cavity, 133
- D
- Dean, W. R., 76, 85
 De Donder chemical affinity, 91
 Defining scalars, 4–6, 8–11
 De Groot, S. R., 87, 98, 99
 DeLaval nozzle, 57, 69
 Density, 29, 48, 49, 62, 77
 spectral, 23
 Density fluctuation, 13–17
 Diaz, J. B., 141, 164, 165
 Diaz-Weinstein formula, 142
 Digital machines, high-speed, 117
 Dini, G. E., 126*n.*
 Dini operator, 126
 Dini transformation, 130
 Direction function, 67–68
 Dirichlet flows, 118
 Dirichlet integral, 143, 146, 159
 Dirichlet problem, 142
 Dirichlet-Neumann boundary-value problem, 143
 Discharge rate, 142, 145
 Discontinuities, permissible, 144
 Discontinuity surface, 109, 111, 116
 Discretization, 121–123, 130–132
 comparison with Neumann kernels, 123–124
 new, 126–128
 Distorted contour, 57
 Distorted speed, 56
 Distortion, 41, 44
 Distribution, radial, 110
 Disturbance, 33–37, 41, 43
 Docklike function, 79, 82
 Donaldson, C. duP., 45
 Drag, 38
 profile, 110
 Dufour effect, 92
 Durand, W. F., 116
- E
- Eckart, C., 98
 Edmonson, N., 53
 Effective mass, 110
 Efficiency, ideal, 115
 optimum, 109
 Ehlers, F. E., 59, 178
 Eigenfunction, 119
 Eigenvalue method, 78
 Eigenvalue theory, 121
 Elasticity, 172
 Electrostatic potential function, 172
 Electrostatics generalized, 171–173
 Energy, equation of, 80, 90, 95, 96
 perturbation, 23, 24, 26
 turbulence, 21, 23
 Energy dissipation, 21–23, 25, 26, 143, 146
 magneto-hydrodynamics, 12
 Energy spectrum function, 19
 Energy transfer, 22, 23
 Enthalpy specific, 96
 Entropy, equations of, 90, 93, 96, 97
 source strength of, 87, 91, 98
 specific, 90, 91
 Entropy-balance equation, 87, 90–91
 Entropy flow, 87, 91
 Equations, axisymmetric-turbulence, 7–10
 continuity, 3, 13, 105
 Euler-Poisson, 176
 gravity waves, 76
 isotropic-turbulence, 1–7

- Equations, motion, 41, 44, 88, 94, 102, 105
 shock, 44
 state, 65
- Equilibrium distribution, Maxwell-Boltzmann, 90
- Euler relation, 97
- Expansion wavefront, 42
- Expansive flow, 48, 49
- F
- Fabri, J., 177, 178
- Ferri, A., 53
- Flow, asymmetric, 133
 axially symmetric, 118, 167
 compressible, 133
 compressive, 48
 Dirichlet, 118
 expansive, 48, 49
 hodograph plane, 68-69
 incompressible, 59, 76, 171
 irrotational, 167-173
 laminar, 141
 irrotational, 47, 48, 62, 76, 128
 isentropic, 55
 Joukowsky, 118
 nonviscous, 76
 physical plane, 69-72
 plane, 118, 167, 168
 potential, 29
 pressure, 149-153
 Riabouchinsky, 133
 shock-free, 41, 43
 sonic, 62
 stable, 43
 subsonic, 41, 43, 57, 62
 supersonic, 41, 47-53, 57, 62
 symmetric, 133
 transonic, 57, 61-72, 173-177
 potential, 29-39
 unstable, 43
 viscous, 87, 88, 93, 141-164
 about a wedge, 175-176
 under wind drag, 153-164
 bounds on, 164
- Flow construction, 55
- Flow function, 109, 110, 116
- Flow pattern, 39
- Fluid acceleration, discontinuity of, 42
 distribution of, 44
- Fluxes and forces, 87, 91, 97
- Fourier coefficients, 137
- Fourier series, 131, 134
- Fourier transform, 58, 169
- Fourier transform theorem, 84
- Frankl, F. I., 62, 73
- Fredholm integral equation, 119
- Friedrichs, K. O., 73, 75, 76, 85
- G
- Garrick, I., 140
- Gauge invariance, 4, 8, 9
- Gaussian distribution, 15
- Generalized axially symmetric potential theory, GASPT, 167
 basic differential equations in, 167-168
 basic singular solutions, 170-171
 correspondence principle in, 168
 fundamental solution, 169
- Germain, P., 177, 178
- Gershgorin, S. A., 117, 119, 140
- Gershgorin's method of conformal mapping, 117-124, 139
- Gibbs equations, 94
- Gibbs function, 97
- Gibbs law, 96
- Goldstein, S., 21, 22, 27, 110, 116, 126*n*.
- Gorter, C. J., 94, 99
- Goursat, E., 73, 85
- Gram-Schmidt orthogonalization ∇ process, 137
- Gravitational instability, 16-17
- Gravitational potential, 16
- Gravity waves, 75-85
 equations governing, 76-78
 linear theory of, 75
- Greenberg, H. J., 164, 165
- Greene, T. R., 75, 85
- Green's functions, 78-82, 119
- Green's identity, 118
- Green's theorem, 80, 83
- Guderley, G., 39, 72, 178
- H
- Hankel functions, 34
- Hansen, A. G., 73
- Heins, A. E., 75, 85, 86
- Heisenberg, W., 19, 20-22, 27
- Heisenberg's transfer function, 21, 22, 24
- Helium II, liquid, 88, 93, 94
- Hilbert, D., 118*n*., 137*n*.
- Hodograph plane, 29, 30, 38, 59, 61, 63
 flow in, 68-69
 method of singularities in, 167-177

Hodograph solutions, 38
 Hoheisel, G., 75, 85
 Howarth, L., 7, 10, 11, 17, 27
 Hugoniot's relations, 102, 104, 106, 107
 Hydrothermodynamics, 87-98
 equations of, energy, 89, 90, 95, 96
 entropy, 90, 93, 96, 97
 force, 89
 fundamental, 87-90, 94-98
 law of conservation of mass, 88-89, 94
 of systems, of several components, 88-93
 of several fluids, 93-94
 Hypercircle method, 141, 143-146, 153
 Hypergeometric function, 57, 59
 Hyman, M., 177

I

Ideal efficiency, 115
 Incompressible flow, 59, 76, 141, 167-173
 Invariance, gauge, 4, 8, 9
 Invariants, Loitsiansky, 7, 12-14
 scalar, 2
 skew, 2
 theory of, 2
 Irreversible processes, 87-91
 thermodynamics of, 87
 Irrotational flow, 47, 48, 55, 62, 76, 128
 Isaacson, E., 76, 86
 Isobars, 65
 Isopycnics, 65
 Isotone operator, 131
 Isotropic tensors, 1-7, 8
 Isotropic turbulence, 1-7
 Isotropy, 1, 15, 22, 92, 98
 Isovel, 65, 69, 70
 Iteration, averaged, 131, 137
 direct, 131, 137
 simple, 126
 Iteration process, 117, 120-121, 130-132,
 135, 139
 convergence of, 120-121

J

Jacchia, L., 26
 Jackson, D., 127*n.*
 Jackson, S. B., 72, 73
 Jansen, L., 99
 Jeans, J. H., 16, 17
 John, F., 76, 86
 Joukowski flows, 118

K

Kantorovitch, L., 139*n.*
 Kantrowitz, A. R., 43*n.*, 45
 Kármán, T. von, 1, 7, 10, 11, 17, 19, 27, 177,
 178
 Kasteleyn, P. W., 99
 Keller, J., 75, 85
 Kellogg, O. D., 140, 177
 Kirkwood, J. G., 104-106, 108
 Kober, H., 117*n.*
 Kolmogoroff, A., 19*n.*
 Kramer, K. N., 116
 Kreisel, G., 76, 86
 Kronecker symbol, 89
 Kuo, Y. H., 43, 45

L

Lagrangian description of gas motion, 101
 Lamb, H., 85, 177
 Landau, L. D., 98
 Landweber, L., 118*n.*
 Laplace's equation, 30, 75, 76
 Law of decay of turbulence, 19, 21
 Legendre function, 168, 169, 173
 Legendre potential, 29
 Levi-Civita, T., 129
 Levi-Civita parametrization, 129
 Lewy, H., 75, 76, 85, 86
 Lighthill, M. J., 60, 73, 140
 Lighthill's series, 59
 Lin, C. C., 19, 27
 Loading of propeller, 109, 110
 Lock, C. N. H., 116
 Loewner, C., 72
 Loitsiansky invariant, 7, 12-14
 Loss, induced, 110

M

McConnell, A. J., 164
 Mach number, 56, 62
 Macroscopic motion, 88, 93, 94
 Macroscopic physics, 90
 Magneto-hydrodynamics, turbulence in, 10-
 13
 Maple, C. G., 165
 Marden, M., 177
 Martin, M. H., 61, 73
 Mass, effective, 110
 Mass coefficient, 110-111, 113, 114
 Maxwell-Boltzmann equilibrium distribu-
 tion, 90

Mazur, P., 93, 94, 98, 99
 Mehler, F. G., 173, 178
 Meixner, J., 98
 Mellink, J. H., 99
 Method, of images, 167, 168, 176
 of singularities, 167-177
 in hodograph plane, 173-175
 of sources and sinks, 167, 171-172
 Meyer, R. E., 41
 Miche, M., 76, 86
 Milne, W. E., 121*n.*,
 Mises, R. von, 73, 116
 Momentum, effective, 110
 increase in, 112
 loss in, 112
 transfer of, 88, 93
 Munk, W. H., 143, 165
 Murnaghan, F. D., 53

N

Naiman, I., 126*n.*
 Navier-Stokes equations, 1, 6, 10, 11, 14,
 88, 92, 98, 141
 Nekrassoff, N., 131*n.*
 Neumann kernels, 118-120
 comparison with discretization, 123-124
 Neumann's argument, 120
 Neumann's problem, 139*n.*
 Nonexistence of transonic potential flow,
 36-39
 Normal atoms, 88
 Normal fluid, 94
 Nozzle, DeLaval, 57, 69
 jet, 133

O

Obukhoff, A. M., 19*n.*
 Ocean currents induced by wind drag, 143
 Onsager, L., 98
 Onsager's theorem, 92
 Open systems, 96
 Optimum efficiency, 109
 Optitz, G., 126*n.*
 Orthogonalization methods, 137-139
 Orthogonalization process, Gram-Schmidt,
 137
 Ostrowski, A., 124*n.*

P

Paley, R. E. A. C., 86

Parameter problem, 132-133
 Parametrization of Levi-Civita, 129
 Partial fraction expansion, 57, 58
 Payne, L. E., 170, 172, 173, 177
 Perturbation velocities, 45
 Perturbations, 22-24, 26, 139*n.*
 over-all rate of decay of, 24, 26
 rate of disappearance, 23, 24, 26
 Peters, A. S., 75, 85
 Phase integral, 33, 36
 Phenomenological coefficient, 92
 Phenomenological relationships, 87, 91, 97
 Phillips, H. B., 139*n.*
 Physical plane, 61, 65, 68, 132
 flow in, 69-72
 method of singularities in, 167-177
 Poincaré, H., 120
 Point of separation, 49, 132
 Poisson's equation, 16, 150
 Poisson's law, 101, 105
 Polytropic gas, 63-65
 Poritsky, H., 75, 85, 177
 Potential of a ring, 169, 170
 Prager, W., 119*n.*, 164
 Pressure, 15, 42, 44, 47-51
 stagnation, 66, 70
 Pressure tensor, 89, 93
 Prigogine, I., 90, 93, 94, 98
 Profile drag, 110
 Propagation, shock-wave, 101
 Propellers, theory of, 109-116
 counterrotating, 109, 110, 112
 ideal efficiency, 115
 Proudman, I., 24, 27
 Pyramid functions, 141, 146-153
 applications of, 149-153
 associated vector fields, 146-149

Q

Quadrature formulas, Gauss, 121*n.*
 trapezoidal, 121
 Quasi-equilibrium, 19, 22-24
 Quasi-equilibrium spectrum, 23, 24
 Quasi-local solutions, 32, 35

R

Radial distribution, 110
 Rayleigh, Lord, 86
 Rayleigh dissipation function, 88, 93
 Rayleigh-Ritz-Trefftz procedures for ob-
 taining upper and lower bounds, 141

- Receding wave, 41
 Reciprocity relations, 82-84
 Reduced weights, 150, 152, 157
 Reflection, Schwarz's principle of, 129
 and transmission properties, 82-85
 Refraction, 41
 Riabouchinsky flow, 133
 Ricatti equation, 67
 Riemann's lemma, 71
 Riemann-Sommerfeld spaces, 173
 Robertse, W. P., 108
 Robertson, H. P., 1-3, 17
 Rosenblatt, A., 139*n.*
 Royden, H., 120*n.*, 121
- S
- Sadowsky, M. A., 171, 177
 Saltzer, C., 126*n.*
 Scalar, 4, 8, 10, 11, 92
 Scalar invariants, 2
 Schiffer, M., 73
 Schiffman, M., 173, 178
 Schwarz's principle of reflection, 129
 Schwarz-Christoffel transformation, 130
 Self-preserving correlation functions, 19*n.*,
 21
 Self-preserving process, 19-21
 Separation assumptions, 48, 49
 Shock, 41-45, 47-49
 equations for, 44
 Shock-free flow, 41, 43
 Shock-line curvature, 48
 Shock path, 44
 Shock strength, 44
 Shock waves, Hugoniot's relations for, 102,
 104, 106, 107
 Similarity spectrum, 23, 24
 Simple wave, 41
 Simpson's rule, 123, 126
 Skew invariants, 2
 Skew tensors, 2-4
 Skinner, R. O., 75, 86
 Solenoidal tensors, 3-4, 8-9
 Sommerfeld, A., 86
 Sommerfeld "Ausstrahlungsbedingung," 78
 Sonic flow, 62
 Sonic line, 35, 36, 57, 61, 65, 70-72, 175
 Sonic speed, 30, 43, 174, 175
 Sources and sinks, method of, 171
 Spectral density, 23
 Spectrum, changing, equation of, 24
 in decay process, concepts of similarity
 of, 19-23
 Spectrum, similarity, 23, 24
 stability of quasi-equilibrium, 23-26
 theory of equilibrium of, 19*n.*
 vorticity, 22, 23
 Speed, distorted, 56
 sonic, 30, 43, 174, 175
 subsonic, 30, 174, 176
 supersonic, 30, 174, 175
 Spencer, D. C., 173, 178
 Spiral angle, 109
 Stagnation points, 59
 Stagnation pressure, 66, 70
 Star-shaped region, 124, 126
 Sternberg, E., 171, 177
 Stewart, C. A., 73
 Stewart, R. W., 19, 21-23, 26, 27
 Stoichiometric number, 89
 Stoker, J. J., 76, 86
 Stokes-Beltrami equations, 167
 Stokes-Navier equation, 1, 6, 10, 11, 14,
 88, 92, 98, 141
 Stream function, 29, 55, 56, 59, 167, 168,
 171, 172, 174, 175
 associated, 169-170
 Stokes-Beltrami, 170
 Streamlines, 47, 57, 65, 68, 69, 72, 171, 172,
 174, 175
 free, 128
 Subsonic disturbances, 33, 34, 36, 37
 Subsonic flow, 41, 43, 57, 62
 Subsonic speed, 30, 174, 176
 Subspaces, 144
 Superfluid, 94
 Superfluid atoms, 88
 Supersonic disturbances, 33, 34, 36, 37
 Supersonic flow, 41, 43, 47-53, 57, 62
 Supersonic speed, 30, 174, 175
 Surface-wave theory, 75
 Surface waves, 78
 Surfaces, control, 112
 free, 75-79, 81-85
 floating-mat types of, 75, 78
 two, joining of, 84, 85
 semi-infinite, 77
 rigid, 76, 79, 81
 Synge, J. L., 141, 164, 165
 Szegő, G., 137*n.*
- T
- Talkin, H. W., 116
 Taylor, G. I., 1, 17, 34, 39
 Taylor's formula, 122

- Taylor's vorticity scale, 24
- Tensors, axisymmetric, 7-10
 first-order, 9
 second-order, 9
 correlation, 1, 3
 and forms, theory of, 1, 9
 isotropic, 1-8
 skew, second-order, 3-4
 third-order, 4-5
 solenoidal, second-order, 3-4
 third-order, 4-5
 pressure, 89, 93
 skew, 2-4
 solenoidal, 3-4, 8-9
 velocity-gradient, 87
 viscous-pressure, 87
- Theodorsen, T., 109, 116, 140
- Theodorsen's conformal-mapping method, 117-126, 139
 advantages of, 123
 in airfoil design, 126*n*.
- Theory, axisymmetric tensors, 8-9
 equilibrium-spectrum or universal-spectrum, 19*n*.
 invariants, 2
 isotropic tensors and forms, 1, 8
 mixture of two fluids, 93
- Thermal diffusion, 92
- Thermodynamics of irreversible processes, 87
- Thermomolecular pressure effect, 94
- Thickstun, W. R., 61
- Thomas, T. Y., 47, 53
- Thrust, 110-114
- Tierney, J. A., 73
- Tisza, L., 98
- Tolhoek, H. A., 99
- Tomada, K., 60, 61, 72, 177, 178
- Tomotika, S., 60, 61, 72, 177, 178
- Torque, 110, 115
- Torsional problem of a beam, 142
- Torsional rigidity, 142
- Total-loss factor, 114
- Townsend, A. A., 19, 21-23, 26, 27
- Transfer function, Heisenberg's, 21-24
- Transonic flow, 57, 61-72, 173-177
- Transonic potential flow, 29-39
 nonexistence of, 36-39
- Transonic problems, 38, 39, 43
- Traupel, W., 119*n*.
- Tricomi, F., 38, 39, 72, 169, 177
- Tricomi equation, 59, 61, 64, 68, 167, 173-177
- Tricomi gas, 63-67
 speed, pressure, density of, 65
- Trilinear forms, 4
- Turbulence, axisymmetric, 7-10
 decay of, 10, 19-23
 law of, 19, 21
 energy of, 21, 23
 experimental evidence, 21-22
 intensity of, 20
 isotropic, 1-7
 similarity concepts, 19-27
 in magneto-hydrodynamics, 10-13
 statistical theory of, 1-17
- U
- Ursell, F., 76, 84-86
- V
- Van Tuyl, A., 171, 177
- Varga, R., 121
- Vector fields, 146-149
- Vectors, axisymmetric, 9
- Velocity, 48
 barycentric, 89
 flux, 76
 perturbation, 45
 reference, 20
 sonic, 30, 43, 174, 175
 of sound, 15, 29, 44
 subsonic, 30, 174, 176
 supersonic, 30, 174, 175
- Velocity potential, 76
- Villat, H., 132*n*., 136, 140
- Villat integral equation, 139
- Virtual density, 49
- Virtual Mach angle, 49
- Virtual pressure ratio, 49
- Viscochemical effects, 98
- Viscosity, coefficient of, 92
 kinematic, 6
 kinematic coefficient of, 20
 ordinary and volume, 98
- Vorticity scale, Taylor's, 24
- Vorticity spectrum, 22, 23
- W
- Wake loss, 113-115
- Wake spiral, 112
- Walsh, J. L., 137*n*.
- Wang, S. C., 61

- Warschawski, S. E., 118*n.*, 126, 140
 Wave, advancing, 41
 plane, 78
 primary, 41, 43, 44
 receding, 41
 secondary, 41, 43
 shock, 101–108
 cylindrical, 104
 Hugoniot's relations for, 102, 104, 106, 107
 nonuniform propagation of plane, 101–108
 path of, 101, 104, 106
 spherical, 104
 strong, 106–108
 ultimate course of, 104
 velocity of propagation of, simple, 101
 simple, 41
 surface, 78
 theory of, 75
 traveling, 75, 79, 80, 85
 progressive, 75
 Wave-maker function, 79
 Wave numbers, 19, 20, 22
 Wavefronts, 41–45
 compression, 42
 expansion, 42
 Wavelength, 31
 Waves, in ducts, 41–45
 gravity (*see* Gravity waves)
 Weinstein, A., 73, 75, 78, 85, 141, 164, 165, 167, 169–171, 177
 Weitz, M., 75, 85
 Whitham, G., 44, 45
 Wiener, Norbert, 86, 139*n.*
 Wiener-Hopf integral equation, 82, 84
 Wittich, H., 126*n.*
- Y
- Yeatman, D., 116
 Yen, K. T., 55
 Yoshihara, H., 72, 178
 Young, D. M., 117, 128–132, 139, 140
- Z
- Zarantonello, E. H., 117, 128–132, 139
 Zarembo, S., 140

