

UNIVERSAL
LIBRARY

OU_172785

UNIVERSAL
LIBRARY

**A COURSE IN PRACTICAL
MATHEMATICS**

AN INTRODUCTION TO PRACTICAL MATHEMATICS. By F. M. SAXELBY, M.Sc., B.A., Head of the Department of Mathematics at the Battersea Polytechnic. With Diagrams. Crown 8vo, 2s. 6d.

EASY PRACTICAL MATHEMATICS : being a Course of Lessons suitable for the Upper Classes of Day Schools, for Evening Schools, and for the Junior Classes in Technical Institutes. By H. E. HOWARD. Crown 8vo, 1s. With Answers, 1s. 6d.

PRACTICAL MATHEMATICS. By A. G. CRACKNELL, M.A., B.Sc., Sixth Wrangler, etc. With Answers to the Examples. Crown 8vo, 3s. 6d.

EXAMPLES AND HOMEWORK IN PRELIMINARY PRACTICAL MATHEMATICS. By T. I. COWLISHAW, M.A., Head of the Mathematical Department, Royal Technical Institute, Salford. Part I., 8vo, 1s. 6d. (KEY, for Teachers only, 1s. 8d. net, post free.) Part II., 1s. 6d. (KEY, for Teachers only, 2s. 2d. net., post free).

FIVE-FIGURE MATHEMATICAL TABLES. For School and Laboratory Purposes. By A. DU PRÉ DENNING, M.Sc. (Birm.), B.Sc. (Lond.), Ph.D. (Heid.). Imperial 8vo., 2s. net.

LONGMANS, GREEN, AND CO.

LONDON, NEW YORK, BOMBAY, AND CALCUTTA

A COURSE IN
PRACTICAL MATHEMATICS

BY
F. M. SAXELBY, M.Sc., B.A.

HEAD OF THE MATHEMATICAL DEPARTMENT AT THE BATTERSEA POLYTECHNIC

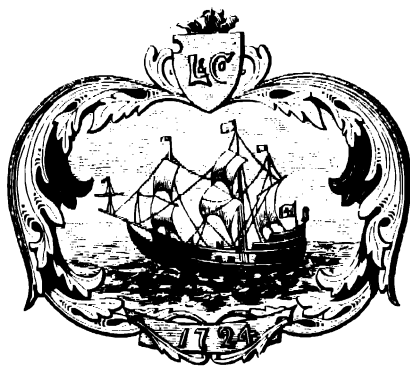

FOURTH EDITION

LONGMANS, GREEN, AND CO.

39 PATERNOSTER ROW, LONDON
NEW YORK, BOMBAY, AND CALCUTTA

1910

P R E F A C E

OBJECTION is sometimes raised to the methods of practical mathematics, on the ground that mathematics is not an experimental science. This is true; but mathematics is built up from a system of conventions which are not arbitrary, but chosen with reference to experience. Thus it is both logically and educationally necessary that the beginner in any branch of mathematics should have the corresponding part of his experience clearly realized and defined.

This has been recognized in the now generally accepted view that the study of geometry should begin with a course of experimental measurement. It is the object of the treatment followed in this book to extend the same method to some other branches of mathematics with special reference to the needs of the technical student.

In the chapters on trigonometry, for instance, while results are nowhere given without proof, the deductive treatment is, as far as possible, accompanied at every step by graphic or arithmetical verification, to enable the student to realise clearly his own experience of space, and to see that he is not dealing with an arbitrary system of symbols alone. Every one has in his own mind the fundamental notion of a rate of increase from which the differential calculus took its rise, and this should be clearly defined before proceeding to the analytical process of differentiation. Accordingly the subject has been arranged so that, after a course in plotting to fix the notion of the function of a variable clearly in the student's mind, he is introduced to the methods of differentiation by a chapter on rates of increase treated by arithmetical and graphic methods. It is only after such a course that most students are ripe for the analytical methods of differentiation. It too often happens that a student who begins with these acquires merely a fatal facility in differentiation, regarding it as a mechanical juggling with symbols, but having no conception of its relation to experience. This intuitional direct vision method

is intended, not to take the place of, but to prepare the way for a more rigorous analytical study of the subject

In the same way, the study of definite integration is preceded by a chapter in which various practical problems on integration are treated entirely by graphic and intuitional methods, so as to stimulate the interest of the student, and to lead him to feel the necessity for analytical methods of integration.

The logical order of a mathematical subject may not be the same as the best educational order, or as the order of its historical development.

The most natural method of advance is by a series of successive approximations to logical rigour, and, in fact, this is the way in which the subject has actually grown up. It is scarcely twenty years since some of the most fundamental positions of the calculus, such as the criterion for the existence of a definite integral, were completely established, yet no one would maintain that the great body of analysis which existed before that time was valueless, because its foundations were not yet truly laid. The process by which the science itself was formed is also the most natural for the mind of the student.

The fundamental laws of vector algebra are each given in connection with some application to mechanics or geometry.

The chapters on solid co-ordinate geometry deal with some parts of the subject which bear on the student's study of practical solid geometry.

A large number of the more technical examples presuppose some knowledge of mechanics or electricity. It is not intended that any one student should work through them all, but that each student should select those examples which interest him most.

F. M. SAXELBY.

May, 1905,

CONTENTS

CHAPTER	PAGE
I. LOGARITHMS	1
II. TRIGONOMETRY—MEASUREMENT OF ANGLES—TRIGONOMETRICAL RATIOS OF ONE ANGLE	8
III. SOLUTION OF TRIANGLES	24
IV. THE ADDITION FORMULÆ	40
V. USE OF FORMULÆ	48
VI. MISCELLANEOUS EQUATIONS AND IDENTITIES	65
VII. PLOTTING OF FUNCTIONS	78
VIII. DETERMINATION OF THE LAWS FOLLOWED BY THE RESULTS OF EXPERIMENTS	127
IX. DETERMINATION OF MEAN VALUES AND AREAS	161
X. RATE OF INCREASE	170
XI. DIFFERENTIATION	188
XII. DIFFERENTIATION OF A PRODUCT, QUOTIENT, AND FUNCTION OF A FUNCTION	209
XIII. CALCULATION OF SMALL CORRECTIONS	217
XIV. EXPANSION OF CERTAIN FUNCTIONS IN SERIES	220
XV. MAXIMA AND MINIMA	225
XVI. INDEFINITE INTEGRALS	234
XVII. DEFINITE INTEGRALS—GRAPHIC METHOD	238
XVIII. DEFINITE INTEGRALS	265
XIX. MEAN VALUES BY INTEGRATION	272
XX. VECTOR ALGEBRA—ADDITION OF VECTORS	276
XXI. MULTIPLICATION OF VECTORS	288
XXII. SOLID GEOMETRY—POINTS AND STRAIGHT LINES	309
XXIII. SOLID GEOMETRY—PLANES	322

CHAPTER		PAGE
XXIV.	VOLUMES OF SOLIDS,	328
XXV.	CENTRES OF GRAVITY	338
XXVI.	MOMENTS OF INERTIA	354
XXVII.	PARTIAL DIFFERENTIATION	362
XXVIII.	MISCELLANEOUS METHODS OF INTEGRATION	370
XXIX.	SOME DIFFERENTIAL EQUATIONS OF APPLIED PHYSICS	378
	EXAMINATION PAPERS	396
	ANSWERS TO THE EXAMPLES	419
	MATHEMATICAL TABLES	445

SUGGESTED COURSE OF READING

THIS course is adapted to the syllabus of the Board of Education, Stages II. and III. For Stage II., students should read through the following course :—

Logarithms and introduction to trigonometry, including solution of right-angled triangles : Chapters I., II., III., §§ 22, 23, 28, 29, 30.

Use of formulæ and equations : Chapters V., VI.

Use of squared paper : Chapters VII., VIII., IX.

Rates of increase and differentiation : Chapters X., XI., §§ 99-106, XIV., XV.

Graphic methods of integration : Chapter XVII.

Addition of vectors : Chapter XX.

Solid geometry of points and straight lines : Chapters XXII., XXIII., §§ 191-192.

Determination of volumes and centres of gravity by graphic methods : Chapters XXIV. §§ 197-199, 201, XXV., omitting examples CVII., CX.

For Stage III. students will require the whole of the book.

The mathematical course for engineering degrees in the University of London also includes many of the subjects treated in this book.

PRACTICAL MATHEMATICS

CHAPTER I

LOGARITHMS

1. AS numerical computation plays an important part in the methods used in this book, the student should have a thorough working knowledge of the use of four-figure logarithms, and, if he has not such a knowledge, should work carefully through this chapter.

It is assumed that the student is familiar with the proofs of the following laws of indices, where m and n are positive whole numbers:—

$$\begin{aligned}x^m \times x^n &= x^{m+n}; \text{ e.g. } x^3 \times x^2 = x^5 \\x^m \div x^n &= x^{m-n}; \text{ e.g. } x^3 \div x^2 = x \\(x^m)^n &= x^{mn}; \text{ e.g. } (x^3)^2 = x^6\end{aligned}$$

2. Fractional and Negative Indices.—The student already knows that $x^3 = x \times x \times x$; $x^7 = x \times x \times x \times x \times x \times x \times x$; and, in general, when n is a positive whole number $x^n = x \times x \times x \times x \dots$ to n factors.

The question now arises: What meaning is to be given to expressions such as $x^{\frac{1}{2}}$, $x^{1\frac{1}{2}}$, x^{-2} , etc., and, in general, to x^n when n is negative or a fraction?

x^n cannot have the same meaning when n is a fraction as it has when n is a positive whole number, but we choose a meaning such that x^n , when n is a fraction, shall satisfy the same laws of indices as are already known to hold good for the case when n is a positive whole number.

The product of two integral powers of x is obtained by adding the indices, and if $x^{\frac{1}{2}}$ obeys the same rule we must have $x^{\frac{1}{2}} \times x^{\frac{1}{2}} = x^{\frac{1}{2} + \frac{1}{2}} = x$. Therefore $x^{\frac{1}{2}}$ is a quantity which gives x as the product when multiplied by itself, *i.e.*—

$$x^{\frac{1}{2}} = \sqrt{x}$$

Similarly

$$x^{\frac{1}{3}} \times x^{\frac{1}{3}} \times x^{\frac{1}{3}} = x$$

and

$$x^{\frac{1}{3}} = \sqrt[3]{x}$$

In general

$$x^{\frac{1}{q}} = \sqrt[q]{x}$$

so also

$$(x^{\frac{1}{q}})^p = x^{\frac{1}{q}} \times x^{\frac{1}{q}} \times x^{\frac{1}{q}} = x^{\frac{p}{q}}$$

i.e. $x^{\frac{p}{q}}$ is the cube of the square root of x , and, in general, $x^{\frac{p}{q}}$ is the p^{th} power of the q^{th} root of x .

If negative powers obey the same index law of multiplication as positive powers, we must have

$$x^{-2} \times x^3 = x^{-2+3} = x$$

$$\text{and } \therefore x^{-2} = \frac{x}{x^3} = \frac{1}{x^2}$$

and in general

$$x^{-p} = \frac{1}{x^p}$$

i.e. a negative power is equal to the reciprocal of the corresponding positive power.

Note in particular that

$$x^{-1} \times x^{+1} = x^{-1+1} = x^0$$

$$\therefore x^0 = x \times \frac{1}{x} = 1$$

whatever the value of x ; *i.e.* the zero power of any quantity is equal to unity.

EXAMPLES.—I.

1. Write down the values of $4^{\frac{1}{2}}$, $9^{\frac{1}{2}}$, $16^{\frac{1}{4}}$, $27^{\frac{1}{3}}$, $1|4^{\frac{1}{2}}$, $961^{\frac{1}{2}}$, $729^{\frac{1}{3}}$.
2. Write down the values of $4^{1\frac{1}{2}}$, $16^{2\frac{1}{2}}$, $81^{\frac{3}{4}}$, $27^{\frac{4}{3}}$, $100^{3\frac{1}{2}}$.
3. Write down the values of 2^{-4} , 3^{-2} , 5^{-2} , $27^{-\frac{1}{3}}$, $125^{-\frac{2}{3}}$, $4913^{-\frac{1}{3}}$.
4. Find the values of 10^{-1} , $10^{-\frac{1}{2}}$, $10^{\frac{1}{2}}$, $10^{\frac{1}{3}}$, 10^1 , $10^{1\frac{1}{2}}$, 10^2 .

3. Logarithms.—Definition: If $y = a^x$, then x is called the logarithm of y to the base a . This is denoted by the abbreviation $\log_a y$. In words, the logarithm of a number to any base is the index of the power of the base which is equal to that number.

The statements $y = a^x$ and $x = \log_a y$ are two different ways of expressing the same fact; *e.g.* we know that $100 = 10^2$; this fact may also be expressed by saying that 2 is the logarithm of 100 to the base 10.

In the same way, we know that

$$8 = 2^3; \text{ i.e. } 3 = \log_2 8$$

$$2 = 4^{\frac{1}{2}}; \text{ i.e. } \frac{1}{2} = \log_4 2$$

$$0\cdot1 = \frac{1}{100^{\frac{1}{2}}} = 100^{-\frac{1}{2}}; \text{ i.e. } -\frac{1}{2} = \log_{100} 0\cdot1$$

and so on.

EXAMPLES.—II.

Write down the values of the following quantities:—

- | | | | |
|-------------------------------------|-----------------------------|------------------------------|----------------------|
| 1. $\log_4 2$. | 2. $\log_9 3$. | 3. $\log_{729} 3$. | 4. $\log_{16} 512$. |
| 5. $\log_{100} 10,000,000$. | 6. $\log_8 \frac{1}{2}$. | 7. $\log_{10} 0\cdot1$. | 8. $\log_{10} 1$. |
| 9. $\log_{\frac{1}{3}} 3\cdot162$. | 10. $\log_{10} 31\cdot62$. | 11. $\log_{10} 0\cdot3162$. | |

4. The three laws of indices given in § 1 may be expressed in logarithmic form.

I. The logarithm of the product of two numbers is the sum of their logarithms.

If a and b be the two numbers, and

$$\begin{aligned} \log_x a &= m, \log_x b = n \\ \text{then } a &= x^m, \text{ and } b = x^n \\ \text{and } \therefore ab &= x^{m+n} \end{aligned}$$

i.e. by the definition of a logarithm

$$\log_x ab = m + n = \log_x a + \log_x b$$

Thus, if we have a table of logarithms to any base, we can substitute addition for multiplication.

EXAMPLE.—We know from tables that $\log_{10} 2.53 = 0.4031$, and $\log_{10} 3.64 = 0.5611$

$$\therefore \log_{10} 2.53 \times 3.64 = 0.4031 + 0.5611 = 0.9642$$

and from the tables we find that this is the logarithm of 9.208 to base 10

$$\therefore \text{the product } 2.53 \times 3.64 = 9.208$$

II. The logarithm of the quotient of two numbers is the difference of their logarithms.

With the same notation as before, we have

$$\frac{a}{b} = \frac{x^m}{x^n} = x^{m-n}$$

$$\text{i.e. } \log_x \frac{a}{b} = m - n = \log_x a - \log_x b$$

Thus we can substitute subtraction for division.

EXAMPLE.—To find $\frac{3.64}{2.53}$, we have

$$\begin{aligned} \log_{10} \frac{3.64}{2.53} &= \log_{10} 3.64 - \log_{10} 2.53 \\ &= 0.5611 - 0.4031 \\ &= 0.1580 \end{aligned}$$

We find from the tables that 0.1580 is the logarithm of 1.439 to base 10

$$\therefore \frac{3.64}{2.53} = 1.439$$

III. The logarithm of the n^{th} power of a number is equal to n times the logarithm of the number.

$$\begin{aligned} \text{Let } m &= \log_x a, \text{ then } a = x^m \\ \text{and } a^n &= (x^m)^n = x^{mn} \\ \text{i.e. } \log_x (a^n) &= mn = n \times \log_x a \end{aligned}$$

This law enables us to perform many arithmetical operations which could not easily be performed by direct arithmetical methods.

EXAMPLE.—To find the value of $(2.53)^{1.3}$.

$$\begin{aligned} \text{We know that } \log_{10} 2.53 &= 0.4031 \\ \text{then } \log_{10} (2.53)^{1.3} &= 1.3 \times \log_{10} (2.53) \\ &= 1.3 \times 0.4031 = 0.5240 \end{aligned}$$

From the tables we find that 0.5240 is the logarithm of 3.342 to base 10. We conclude that $(2.53)^{1.3} = 3.342$.

5. Use of Tables.—Tables of logarithms to base 10 are given at the end of the book. Some explanation is necessary as to the arrangement and use of these tables.

The integral part of the logarithm of a number to base 10 may be found by considering the two integral powers of 10 between which the number lies; thus, $343\cdot2$ lies between 10^2 and 10^3 , and therefore its logarithm lies between 2 and 3; $0\cdot00342$ lies between $0\cdot01$ and $0\cdot001$, *i.e.* between 10^{-2} and 10^{-3} ; and therefore its logarithm lies between -2 and -3 .

The decimal part of the logarithm of a number is given in the tables.

Thus, to find $\log 343\cdot2$, we find the first two figures, 34, on the left-hand side of the tables; the next figure, 3, is found at the top. In the horizontal line opposite to 34, and in the column under 3, we find 5353. This is the decimal part of $\log 343$. To account for the next figure, 2, we notice that in the table of differences, at the right-hand side of the tables, the difference for 2 in the horizontal line opposite to 34 is given as 3.

This must be added to the value 5353 already found to correspond to 343. Thus we find that the decimal part of $\log_{10} 343\cdot2$ is $0\cdot5356$. We have seen above that $\log_{10} 343\cdot2$ lies between 2 and 3, and therefore $\log 343\cdot2 = 2\cdot5356$.

It will be noticed that the arrangement is somewhat different in the part of the tables corresponding to numbers whose first significant figure is 1.

The logarithms here increase so rapidly with the numbers that two sets of differences are required for the interval between two numbers whose second significant figures differ by 1.

Thus to find $\log 126\cdot3$, we know as before that the integral part is 2. To find the decimal part, we get as before the value 1004 corresponding to 126.

The difference for 3 must now be sought in the horizontal line opposite to the value 1004 already found; this difference is 10, and therefore the decimal part of the logarithm is $0\cdot1014$, and $\log 126\cdot3 = 2\cdot1014$.

To find the decimal part of $\log 125\cdot3$ on the other hand, we should look for the difference for 3 in the upper line opposite to 0969, which corresponds to the first 3 significant figures, 125, of the number whose logarithm is to be found. This difference is 11, and thus we get $\log 125\cdot3 = 2\cdot0980$.

Since $10^0 = 1$, $\log_{10} 1 = 0$, and therefore the logarithm of any number less than 1 is negative. This is true for logarithms to any base whatever.

It is found convenient to keep the decimal part of all the logarithms positive, and to restrict the negative sign to the integral part. Thus, if the logarithm of a number is $-0\cdot3$, we write it $\bar{1}\cdot7$, *i.e.* $-1 + 0\cdot7$; if a logarithm is $-3\cdot7$, we write it $\bar{4}\cdot3$, *i.e.* $-4 + 0\cdot3$.

This device enables us to use the same tables for all numbers, whether greater or less than 1. For any number less than 1 may be obtained from a number greater than 1 having the same digits by dividing by 10 an exact number of times.

This is equivalent to subtracting a whole number from the logarithm without altering the positive decimal part of the logarithm.

Thus $0\cdot03432$ is obtained from $343\cdot2$ by dividing by 10^4 .

$$\begin{aligned}\therefore \log 0\cdot03432 &= \log 343\cdot2 - \log 10^4 \\ &= 2\cdot5356 - 4 \\ &= \bar{2}\cdot5356\end{aligned}$$

Note that the decimal part of the logarithm is unaltered. Thus the logarithm of $0\cdot03432$ could be found directly from the tables by first finding as before the decimal part of the logarithm of 3432, and prefixing the integer 2, because $0\cdot03432$ lies between 10^{-1} and 10^{-2} .

EXAMPLE.—To find $\log 0\cdot01594$ from the tables.

In the horizontal line opposite to 15, and in the column under 9, we find 2014. The difference for the next figure 4 in the horizontal line opposite to 2014 is 11.

Adding this to 2014, we get 2025 as the decimal part of $\log 0\cdot01594$. Since the number lies between 0·1 and 0·01, its logarithm lies between 1 and 2.

$$\therefore \log 0\cdot01594 = \bar{2}\cdot2025$$

6. Antilogarithms.—When the logarithm of a number is given and we wish to find the number, we may of course use the table of logarithms, but it is more expeditious to make use of a separate table of antilogarithms. This table gives the number corresponding to any given logarithm to base 10. The arrangement is similar to that of the table of logarithms.

EXAMPLE.—The logarithm of a certain number is found to be $\bar{2}\cdot0361$: to find the number.

We find, by using the table of antilogarithms in the same way as we used the table of logarithms, that the antilogarithm of 0·0361 is 1086. These are the significant figures of the result, but we do not yet know the position of the decimal point. This is found by considering the integral part of the logarithm. Since the logarithm is made up of $\bar{2}$ and a positive decimal, it lies between $\bar{1}$ and $\bar{2}$, and therefore the number lies between 0·1 and 0·01, *i.e.* the number is 0·01086.

7. Napierian Logarithms.—Logarithms to base 10 are used for numerical calculations, but the student will also meet with logarithms to base e , where e is a quantity defined by means of the series

$$1 + 1 + \frac{1}{1 \times 2} + \frac{1}{1 \times 2 \times 3} + \frac{1}{1 \times 2 \times 3 \times 4} + \dots$$

It can be shown that, however many terms of this series are taken, the sum is never greater than a definite limiting value $e = 2\cdot718\dots$, and that the sum may be made as nearly equal to e as we please by taking a sufficient number of terms of the series. The quantity e is accordingly defined as the limit of the sum of the series.

$$1 + 1 + \frac{1}{1 \times 2} + \frac{1}{1 \times 2 \times 3} + \frac{1}{1 \times 2 \times 3 \times 4} + \dots$$

as the number of terms is indefinitely increased. The quantity e will be more fully treated in Chapter XXIX., when the student is in a better position to understand the theory of the subject.

Such logarithms are variously called **natural**, **Napierian**, or **hyperbolic logarithms**. The reason for the occurrence of this base will appear to the student at a later stage in his work.

The logarithm of a number to base e is obtained from its logarithm to base 10 by multiplying by 2·3026.

To verify this from the tables, let p be the logarithm of a number n to base 10. Then, by the definition of a logarithm, $n = 10^p$.

We find from the tables that

$$\log_{10} e = \log_{10} 2\cdot718 = 0\cdot4343$$

$$\therefore e = 10^{0\cdot4343}$$

$$\text{and } 10 = e^{2\cdot3026} = e^{2\cdot3026p}$$

$$\therefore \text{substituting } n = e^{2\cdot3026p}$$

$$\text{i.e. } \log_e n = 2\cdot3026p = 2\cdot3026 \log_{10} n$$

EXAMPLES.—III.

Find from the tables the values of the following logarithms to base 10:—

1. $\log 200$, $\log 20$, $\log 2$, $\log 0\cdot0002$.

2. $\log 7837$, $\log 783\cdot7$, $\log 78\cdot37$, $\log 7\cdot837$, $\log 0\cdot7837$, $\log 0\cdot07837$, $\log 0\cdot007837$.

3. $\log 2 \cdot 156 \times 10^4$, $\log 2 \cdot 156 \times 10^{-4}$, $\log 2 \cdot 156 \times 10^{-7}$.
 4. $\log 3 \cdot 142$, $\log 0 \cdot 2965$, $\log 46 \cdot 72$, $\log 7 \cdot 864$, $\log 11 \cdot 32$, $\log 11 \cdot 72$, $\log 0 \cdot 01568$,
 $\log 0 \cdot 002374$.
 5. Find the numbers which have the following logarithms to base 10 :—
 $3 \cdot 1562$, $2 \cdot 3010$, $1 \cdot 4771$, $0 \cdot 5631$, $1 \cdot 2759$, $3 \cdot 3648$, $2 \cdot 7649$.
 6. Find the values of the following logarithms :—
 $\log_e 2 \cdot 31$, $\log_e 3 \cdot 57$, $\log_e 4 \cdot 62$, $\log_e 8 \cdot 86$.

B. The methods of working with logarithms and of arranging the work will be understood from the following examples :—

EXAMPLE (1).—Evaluate $1 \cdot 362 \times 23 \cdot 54 \times 13 \cdot 05$.

$$\log 1 \cdot 362 = 0 \cdot 1342$$

$$\log 23 \cdot 54 = 1 \cdot 3718$$

$$\log 13 \cdot 05 = 1 \cdot 1155$$

$$\text{adding, } \log 1 \cdot 362 \times 23 \cdot 54 \times 13 \cdot 05 = 2 \cdot 6215 = \log 418 \cdot 3$$

$$\therefore \text{the required product} = 418 \cdot 3$$

EXAMPLE (2).—Evaluate $\frac{31 \cdot 35 \times 0 \cdot 003621}{2 \cdot 534 \times 76 \cdot 52} = x$.

$$\log 31 \cdot 35 = 1 \cdot 4962$$

$$\log 0 \cdot 003621 = 3 \cdot 5588$$

$$\log 2 \cdot 534 = 0 \cdot 4038$$

$$\log 76 \cdot 52 = 1 \cdot 8838$$

$$\text{adding, } \log 31 \cdot 35 \times 0 \cdot 003621 = 1 \cdot 0550$$

$$\log 2 \cdot 534 \times 76 \cdot 52 = 2 \cdot 2876$$

$$\text{subtracting, } \log x = 4 \cdot 7674 = \log 0 \cdot 0005853$$

$$\therefore \frac{31 \cdot 35 \times 0 \cdot 003621}{2 \cdot 534 \times 76 \cdot 52} = 0 \cdot 0005853$$

EXAMPLE (3).—Evaluate $(0 \cdot 0326)^{1 \cdot 2}$.

$$\log 0 \cdot 0326 = 2 \cdot 5132$$

$$1 \cdot 2$$

$$1 \cdot 2 \times 0 \cdot 5132 = 0 \cdot 6158$$

$$1 \cdot 2 \times 2 = -2 \cdot 4$$

$$\log (0 \cdot 0326)^{1 \cdot 2} = 2 \cdot 2158 = \log 0 \cdot 01644$$

$$\therefore (0 \cdot 0326)^{1 \cdot 2} = 0 \cdot 01644$$

In the above we have to multiply a number which is partly positive and partly negative by a positive number. We multiply the two parts separately, and add the results with their proper signs.

EXAMPLE (4).—Evaluate $(0 \cdot 0314)^{-2 \cdot 1}$.

Consider a negative power as the reciprocal of the corresponding positive power.

$$(0 \cdot 0314)^{-2 \cdot 1} = \frac{1}{(0 \cdot 0314)^{2 \cdot 1}}$$

$$\log (0 \cdot 0314) = 2 \cdot 4969$$

$$2 \cdot 1$$

$$1 \cdot 0435$$

$$-4 \cdot 2$$

$$\log (0 \cdot 0314)^{2 \cdot 1} = 4 \cdot 8435$$

$$\log 1 = 0 \cdot 0$$

$$\log (0 \cdot 0314)^{-2 \cdot 1} = 3 \cdot 1565 = \log 1434$$

The value of $\log (0\cdot0314)^{-2\frac{1}{2}}$ in the last line is obtained by subtracting $\log (0\cdot0314)^{2\frac{1}{2}}$ from $\log 1$.

EXAMPLE (5).— Evaluate $\sqrt[3]{132\cdot5}$.

$$\begin{aligned}\sqrt[3]{132\cdot5} &= (132\cdot5)^{\frac{1}{3}} \\ \log 132\cdot5 &= 2\cdot1222 \\ \log (132\cdot5)^{\frac{1}{3}} &= \frac{1}{3} \log 132\cdot5 = 0\cdot7074 = \log 5\cdot098 \\ \therefore \sqrt[3]{132\cdot5} &= 5\cdot098\end{aligned}$$

EXAMPLE (6).— Evaluate $\sqrt[3]{0\cdot01325}$.

$$\begin{aligned}\log 0\cdot01325 &= \bar{2}\cdot1222 \\ \log \sqrt[3]{0\cdot01325} &= \frac{1}{3}(\bar{2}\cdot1222) \\ &= \frac{1}{3}(\bar{3} + 1\cdot1222) \\ &= 1\cdot3741 = \log 0\cdot2367 \\ \therefore \sqrt[3]{0\cdot01325} &= 0\cdot2367\end{aligned}$$

Here we have to divide $\bar{2}$ by 3. As we wish to keep the decimal part of the quotient positive, we write $\bar{3} + 1$ for $\bar{2}$, so that the negative part can be divided exactly by 3.

In working with four-figure logarithms it is found that the results are more likely to be accurate, especially in long calculations, if all logarithms are set down in vertical columns, as in the above examples.

EXAMPLES.—IV.

Evaluate the following expressions to as close a degree of accuracy as the use of four-figure tables will permit:—

- | | | |
|---|--|--|
| 1. $0\cdot035621 \times 25780$. | 2. $0\cdot013640 \times 153\cdot27$. | 3. $225\cdot85 \times 179$. |
| 4. $1362 \times 0\cdot0251$. | 5. $\frac{2\cdot006}{0\cdot00345}$. | 6. $\frac{152\cdot05641}{0\cdot0005649}$. |
| 7. $\frac{5346\cdot257}{1386497}$. | 8. $\frac{462\cdot17}{1\cdot12534}$. | 9. $\frac{12\cdot36 \times 21\cdot5}{32\cdot9}$. |
| 10. $0\cdot0352 \times 125 \times 0\cdot000561$. | 11. $\frac{0\cdot0065 \times 136}{0\cdot01324 \times 0\cdot005621}$. | |
| 12. $\frac{0\cdot1639 \times 52100 \times 0\cdot0253}{0\cdot00035 \times 1\cdot0264}$. | 13. $\sqrt{251}$. | 14. $\sqrt[5]{0\cdot0742}$. |
| 15. $\sqrt[3]{3615}$. | 16. $\sqrt[3]{36\cdot15}$. | 17. $\sqrt[3]{0\cdot03615}$. |
| 18. $\sqrt{21\cdot7}$. | 19. $\sqrt{2\cdot17}$. | 20. $\sqrt[3]{2512}$. |
| 21. $\sqrt[3]{25\cdot12}$. | 22. $\sqrt[3]{251\cdot2}$. | 23. $(0\cdot059)^{1\cdot4}$. |
| 24. $\sqrt[3]{2\cdot512}$. | 25. $21^{3\cdot0}$. | 26. $(0\cdot1754)^{-3\cdot3}$. |
| 27. $(1\cdot34)^{0\cdot08}$. | 28. $(0\cdot0351)^{-2\cdot0}$. | 29. $(0\cdot0532)^{1\cdot4}$. |
| 30. $(0\cdot1854)^{-0\cdot003}$. | 31. $(0\cdot01625)^{-25\cdot3}$. | 32. $12^{-0\cdot8}$. |
| 33. $(0\cdot0651)^{-3\cdot4}$. | 34. $7^{3\cdot615}$. | 33. $(1\cdot305)^{-2\cdot80}$. |
| 35. $(1\cdot333)^{-0\cdot3}$. | 37. $(25\cdot61)^{-1\cdot27}$. | 41. $(0\cdot2543)^{-0\cdot025}$. |
| 36. $(0\cdot036)^{-0\cdot023}$. | 40. $(0\cdot32655)^{-2\cdot3418}$. | 44. $(0\cdot3489)^{0\cdot010}$. |
| 42. $(\log_8 2\cdot963)^{-2\cdot30}$. | 43. $(0\cdot2461)^{\log_{10} 12\cdot64}$. | 47. $\frac{(1\cdot036)^{-2\cdot0}}{\sqrt[3]{21\cdot2}}$. |
| 45. $(0\cdot1043)^{-1\cdot25}$. | 46. $\frac{1}{4} \times (1\cdot052)^{-\frac{1}{3}}$. | |
| 48. $\frac{356200}{\sqrt[3]{67 \times 21}}$. | 49. $\frac{25\cdot63 \times 0\cdot00036}{(0\cdot0125)^2 \times \log_{10} 29\cdot3}$. | 50. $\frac{135\cdot7 \times (0\cdot21)^2}{\log_{10} 31\cdot3}$. |
| 51. $59\cdot32 \times (\log_{10} 261)^3$. | 52. $\frac{341 \times \sqrt[3]{0\cdot036} \times 252\frac{3}{4}}{(1\cdot03)^2 \times \log_{10} 15\cdot71}$. | 53. $\frac{55 \times \sqrt[4]{0\cdot0621} \times 53\frac{1}{2}}{0\cdot0035 \times (20\cdot06)^{-0\cdot3}}$. |

CHAPTER II

TRIGONOMETRY—MEASUREMENT OF ANGLES— TRIGONOMETRICAL RATIOS OF ONE ANGLE

9. Measurement of Angles.—Draw two straight lines OX and OY at right angles. If XO and YO are produced to X' and Y' they divide the plane in which they lie into four quadrants, XOY , YOX' , $X'OY'$, $Y'OX$.

Suppose the straight line OP starts from the position OX , and moves so that P describes a circle about O as centre in a direction opposite to that of the motion of the hands of a clock, then the line OP is said to generate the angle XOP as it passes round.

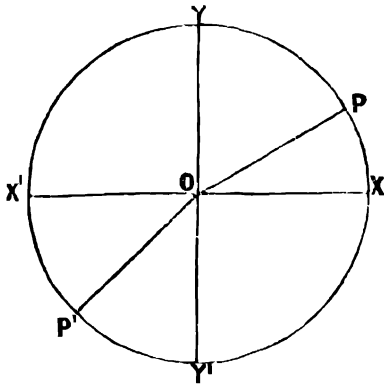

FIG. 1.

The angle XOY is divided into 90 equal parts, called degrees, and for any position of P the angle XOP is measured by the number of degrees through which OP has turned.

One degree is divided into 60 minutes, and one minute into 60 seconds.

The quadrants are numbered, the 1st, 2nd, 3rd, and 4th, after the order in which OP passes through them.

When OP is in the 2nd quadrant YOX' it makes an obtuse angle with OX ; when OP is in the 3rd quadrant $X'OY'$ the angle XOP is still measured in the same direction, passing through OY .

Similarly, when OP is in the 4th quadrant, XOP means the angle between OX and OP traced out in a counter-clockwise direction through OY and OX' , and not the acute angle between OX and OP .

When OP comes again to its original position OX , it may go on revolving round O in the same direction, so that it may generate an angle as large as we please: e.g. an angle of 750° is one which is formed when the line OP starts at OX , and makes two complete revolutions, and then turns through 30° in addition.

10. Positive and Negative Angles.—If the line OP revolves in a counter-clockwise direction as in the last §, the angle which it generates is said to be positive. If OP starts from the position OX , and revolves through the positions OY' , OX' , OY , in the same direction as the hands of a clock, it is said to generate a negative angle.

A negative angle may contain any number of degrees; e.g. an angle of -135° is formed when OP revolves through the 4th quadrant XOY' and halfway through the 3rd, $Y'OX'$, in a clockwise direction.

Similarly $-1000^\circ = -11 \times 90^\circ - 10^\circ$, and therefore an angle of -1000° is formed when OP turns through 11 right angles in a clockwise direction, and then continues to revolve through 10° in addition. Thus the generating line of an angle of -1000° is in the 1st quadrant.

11.—Circular Measure of Angles.—Angles may also be measured in circular measure. When P moves a distance XP equal to the radius OX along the circumference of the circle XYX' , the angle XOP which OP generates is called a radian.

It can be proved that when P moves completely round the circle XYX' to its first position X , the whole circumference traced out by P is equal to

$$2\pi \cdot OX = 2\pi \cdot XP$$

where π is equal to $3\cdot1416 \dots$

And since the angle XOP is proportional to the arc XP ,

$$OP \text{ generates an angle which} = 2\pi \cdot \frac{XP}{OX} = 2\pi \text{ radians}$$

$$\therefore 360^\circ = 2\pi \text{ radians}$$

$$\text{and 1 radian} = \frac{360^\circ}{2\pi} = 57\cdot2958^\circ$$

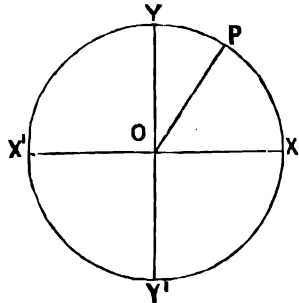

FIG. 2.

We shall usually find it sufficiently accurate to take 1 radian equal to $57\cdot3^\circ$.

It is useful to remember the following values :—

$$2 \text{ right angles} = 180^\circ = \pi \text{ radians ;}$$

$$1 \text{ right angle} = 90^\circ = \frac{\pi}{2} \text{ radians ;}$$

$$60^\circ = \frac{\pi}{3} \text{ radians ; } 30^\circ = \frac{\pi}{6} \text{ radians ; } 45^\circ = \frac{\pi}{4} \text{ radians.}$$

The values in radians of angles from 0° to 90° are given in the tables.

EXAMPLE (1).—To express 125° in radians.

We have $57\cdot3^\circ = 1 \text{ radian}$

$$125^\circ = \frac{125}{57\cdot3} = 2\cdot18 \text{ radians}$$

Using the tables, we have

$$125^\circ = 90^\circ + 35^\circ = 1\cdot5708 + 0\cdot6109 = 2\cdot1817 \text{ radians}$$

Similarly, to convert radians to degrees multiply by $57\cdot3$, or use the tables.

EXAMPLE (2).—A flywheel of 2·5-ft. radius is revolving at 120 revolutions per minute, what is the speed of a point on its rim?

Any radius of the wheel turns through 120 revolutions per minute = 2 revolutions per second = 4π radians per second.

By the definition of a radian we know that when the radius turns through one radian its extremity moves through a distance equal to the radius, i.e. through 2·5 feet.

Therefore, in one second a point on the rim of the wheel travels through $4\pi \times 2\cdot5 = 31\cdot42$ feet per second, and the speed of a point on the rim is 31·42 feet per second.

EXAMPLES.—V.

1. Draw figures to show the following angles, and express them in radians :—
 152° , 205° , -270° , 300° , -840° , 1350° .
2. Draw a figure to show angles of 1, 2, 3, 4, and 5 radians.
3. Make a protractor to measure angles less than two right angles correct to 0.1 radian.
4. Draw figures to show angles of 1.3 and 2.9 radians, and express them in degrees.
5. Find the length of the arc which subtends an angle of 41° at the centre of a circle of 11-ft. radius.
6. A flywheel of 3-ft. radius is revolving at 260 revolutions per minute : what is the speed of a point on the rim ?
7. The earth moves round the sun once a year in a circle (approximately) of 92.8×10^6 miles radius : find its velocity in miles per second.
8. The earth revolves round its axis once in 24 hours : through what decimal of a radian does it revolve in one second ? Find the speed, in feet per second, of a point on the equator. Radius of earth = 3963 miles.
9. The armature of a dynamo is 1 foot in diameter, and is revolving at 1100 revolutions per minute. What is the speed of a point on the outside of the armature ?
10. Through what angles do the large and small hands of a clock respectively turn between 11.15 a.m. and 2.30 p.m. ; and between 3.44 a.m. and 7.31 p.m. ?
11. What are the angles, measured in a positive direction from the minute to the hour-hand of a clock, at the following times : 3.7, 6.10, 7.15, 9.25 ?

12. Co-ordinates of a Point.—If a point is supposed free to move about on a surface, we require to know two quantities before we can determine its position ; e.g. to fix the position of a point on the earth's surface we specify its latitude and longitude, *i.e.* its distances measured in degrees from the equator and the meridian of Greenwich.

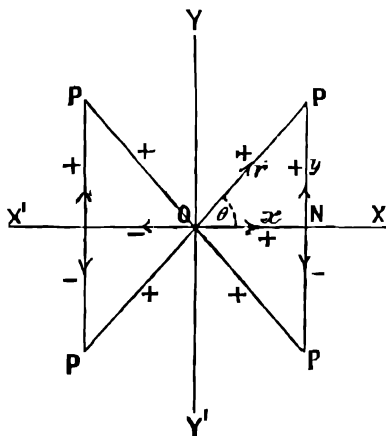

FIG. 3.

In the same way the position of a point on a plane is fixed when its distances from two straight lines in the plane are known.

From any position of the point P in § 9 draw PN perpendicular to the axis X'OX.

Let $x = ON$ measured from O to N and $y = NP$ measured from N to P. Then x and y , taken with their proper signs, are called the rectangular co-ordinates of the point P, y is called the *ordinate* and x the *abscissa* of the point P.

The signs are chosen as follows :—

x is positive when measured from left to right in the direction X'OX, and negative when measured from right to left in the direction XOX'.
 y is positive when measured upwards in the direction Y'OY, and negative when measured downwards in the direction YOY'.

Thus, when P is in the first quadrant,

$x = ON$ and is positive, $y = NP$ and is positive

When **P** is in the second quadrant,
 x is negative, y is positive

When **P** is in the third quadrant,
 x is negative, y is negative

When **P** is in the fourth quadrant,
 x is positive, y is negative

P is described as the point (x, y) ; e.g. the point $(2, 3)$ is the point whose abscissa is 2 and ordinate 3.

Polar Co-ordinates.—The position of the point **P** is also determined if we know the length r of the line **OP** and the angle $\text{XOP} = \theta$, which it generates in passing from **OX** to its position **OP**. These are called the **polar co-ordinates** of the point **P**.

θ is measured positively in a counter-clockwise direction from **OX** to **OP**, and r is measured from **O** to **P** and taken positive in all four quadrants.

P is described as the point (r, θ) ; e.g. the point $(2, 25^\circ)$ is the point for which $r = 2$ and $\theta = 25^\circ$.

EXAMPLES.—VI.

1. Draw a figure to show the positions of the points whose rectangular co-ordinates are given as follows: $(2, 3)$; $(5, 2)$; $(3, 1)$; $(-3, 2)$; $(-5, -3)$; $(-4, 3)$; $(2, -3)$; $(1.3, -3.2)$; $(-4.3, -3.4)$.

2. Show in a figure the positions of the points whose polar co-ordinates are given as follows: $(1, 15^\circ)$; $(2, 30^\circ)$; $(2, 64^\circ)$; $(2, 110^\circ)$; $(2, 220^\circ)$; $(2, 300^\circ)$; $(2, -60^\circ)$; $(2, -100^\circ)$.

3. Find by measurement from your figure the polar co-ordinates of the first 6 points in Example 1.

4. Find by measurement the rectangular co-ordinates of the first 6 points in Example 2.

13. Trigonometrical Ratios of an Acute Angle.—Let θ be any acute angle **NOP**, let **ON** = x and **NP** = y be the rectangular co-ordinates of **P**, and let **OP** = r . Then the trigonometrical ratios of the angle θ are defined as follows:—

$$\begin{aligned} \text{sine } \theta, \text{ written } \sin \theta &= \frac{\text{NP}}{\text{OP}} = \frac{y}{r} \\ \text{cosine } \theta, \text{ written } \cos \theta &= \frac{\text{ON}}{\text{OP}} = \frac{x}{r} \\ \text{tangent } \theta, \text{ written } \tan \theta &= \frac{\text{NP}}{\text{ON}} = \frac{y}{x} \\ \text{cosecant } \theta, \text{ written } \operatorname{cosec} \theta &= \frac{\text{OP}}{\text{NP}} = \frac{r}{y} \\ \text{secant } \theta, \text{ written } \sec \theta &= \frac{\text{OP}}{\text{ON}} = \frac{r}{x} \\ \text{cotangent } \theta, \text{ written } \cot \theta &= \frac{\text{ON}}{\text{NP}} = \frac{x}{y} \end{aligned}$$

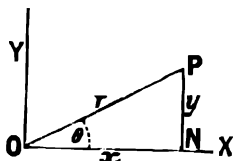

FIG. 4.

EXAMPLE (1).—Find by a graphic method the sine, cosine, and tangent of 35° .

This is most conveniently done on squared paper. The student should draw the figure on a large scale, and verify the measurements for himself.

Take two axes, **OX** and **OY**, at right angles, and set off the angle $\text{XOP} = 35^\circ$ by means of a protractor.

With centre O and radius equal to unit length on some convenient scale, cut off OP , and draw PN perpendicular to OX .
Then we have

$$\sin 35^\circ = \frac{NP}{OP} = NP = 0.574$$

$$\cos 35^\circ = \frac{ON}{OP} = ON = 0.819$$

$$\tan 35^\circ = \frac{NP}{ON} = \frac{0.574}{0.819} = 0.700$$

Note that when, as in this example, we take OP as the unit of length, the sine and cosine of θ are equal to the rectangular co-ordinates y and x of the point P .

NOTE.—The notation $\sin^{-1} x$ is used to denote an angle whose sine is x , e.g. 35° , or 0.61 radian is a value of $\sin^{-1} 0.574$. Similarly, $\cos^{-1} x$ and $\tan^{-1} x$ denote angles whose cosine and tangent are equal to x .

EXAMPLE (2).—Find the acute angle whose tangent is equal to 0.8 .

Here we require to find the angle θ , so that we may have

$$\frac{NP}{ON} = 0.8$$

The student should draw the figure for himself.

Using squared paper, set off on the axis of x the length ON equal to unity on some convenient scale. On the ordinate passing through N set off NP equal to 0.8 on the same scale. Join OP . Then $\angle NOP$ is the required angle. We find by measurement that the angle $\angle NOP = 38.7^\circ$.

EXAMPLES.—VII.

1. Set off on the axis of x , $ON_1 = 1$, $ON_2 = 2$, $ON_3 = 3$. Draw any straight line OP in the first quadrant. Erect ordinates N_1P_1 , N_2P_2 , N_3P_3 , meeting OP in P_1 , P_2 , and P_3 . Find by measurement the values of $\frac{N_1P_1}{ON_1}$, $\frac{N_2P_2}{ON_2}$, $\frac{N_3P_3}{ON_3}$, and compare them. Also measure $\frac{N_1P_1}{ON_1}$, $\frac{N_2P_2}{ON_2}$, $\frac{N_3P_3}{ON_3}$, and compare.

What do you infer from this experiment with respect to the sine and tangent of an angle?

2. Find by construction the values of $\sin 25^\circ$, $\cos 40^\circ$, $\tan 65^\circ$, $\sin 44^\circ$, $\tan 45^\circ$, $\cos 75^\circ$.

3. Find by construction the values of the following acute angles in degrees: $\sin^{-1} 0.39$, $\sin^{-1} 0.89$, $\cos^{-1} 0.6$, $\cos^{-1} 0.85$, $\tan^{-1} 0.4$, $\tan^{-1} 0.7$, $\tan^{-1} 1.73$, $\tan^{-1} 5$.

14. Trigonometrical Ratios of an Angle greater than a Right Angle.—When the angle $\angle NOP$ is greater than a right angle, its trigonometrical ratios are defined in the same way as in § 13, but it is also necessary to take account of their signs.

We shall consider the signs of the trigonometrical ratios when the generating line, OP , of the angle θ lies in each of the four quadrants (Fig. 3).

When OP is in the first quadrant, x , y , and r are all positive, and therefore the ratios of the angle $\angle XOP$ are all positive.

When OP is in the second quadrant, we have

x negative, y positive, and r positive

In what follows, ON , NP , and OP represent the *numerical* values of the lengths of the lines indicated without taking account of direction.

$$\sin \theta = \frac{y}{r} = \frac{+NP}{+OP} = + \sin \text{POX}$$

$$\cos \theta = \frac{x}{r} = \frac{-ON}{+OP} = - \cos \text{POX}$$

$$\tan \theta = \frac{y}{x} = \frac{+NP}{-ON} = - \tan \text{POX}$$

When OP is in the third quadrant, we have

x negative, y negative, and r positive

$$\sin \theta = \frac{y}{r} = \frac{-NP}{+OP} = - \sin \text{X'OP}$$

$$\cos \theta = \frac{x}{r} = \frac{-ON}{+OP} = - \cos \text{X'OP}$$

$$\tan \theta = \frac{y}{x} = \frac{-NP}{-ON} = + \tan \text{X'OP}$$

When OP is in the fourth quadrant, we have

x positive, y negative, and r positive

$$\sin \theta = \frac{y}{r} = \frac{-NP}{+OP} = - \sin \text{POX}$$

$$\cos \theta = \frac{x}{r} = \frac{+ON}{+OP} = + \cos \text{POX}$$

$$\tan \theta = \frac{y}{x} = \frac{-NP}{+ON} = - \tan \text{POX}$$

We have here expressed the ratios of the angle θ when the generating line OP is in any quadrant in terms of the ratios of an acute angle.

EXAMPLE.—To construct an angle in the third quadrant whose sine is $-\frac{5}{13}$, and to find by measurement its cosine and tangent.

This is most easily done on squared paper.

Take two axis, OX and OY , at right angles. We require to find a point for which $y = -5$, and $r = 13$.

Take a point M on the axis of y , such that $OM = -5$, and draw MP parallel to XOX' . Then all points for which $y = -5$ lie on the straight line MP .

To make $r = 13$, with centre O and radius 13 , describe a circle cutting MP at P in the third quadrant. Join OP .

Then XOP is the required angle in the third quadrant whose sine is $-\frac{5}{13}$.

To find the cosine and tangent of the angle XOP , draw PN perpendicular to OX' .

Then, by measurement, the value of x for the point $P = ON = -12$

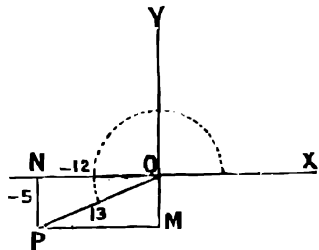

FIG. 5.

$$\text{and } \therefore \cos \text{XOP} = \frac{x}{r} = -\frac{12}{13}$$

$$\tan \text{XOP} = \frac{y}{x} = \frac{-5}{-12} = \frac{5}{12}$$

Practical Mathematics

EXAMPLES.—VIII.

1. Construct an angle of 40° . Find by measurement its sine, cosine, and tangent.
2. Construct an angle of 140° . Find by measurement its sine, cosine, and tangent.
3. Construct an angle of 220° , and find its sine, cosine, and tangent.
4. Construct an angle of 310° , and find its sine, cosine, and tangent.
5. Construct an acute angle whose sine is $\frac{3}{5}$, and find its cosine and tangent.
6. Construct an angle in the second quadrant whose sine is $\frac{3}{5}$, and find by measurement its cosine and tangent.
7. Construct an angle in the third quadrant whose sine is $-\frac{3}{5}$, and find its cosine and tangent.
8. Construct an angle in the fourth quadrant whose sine is $-\frac{3}{5}$, and find its cosine and tangent.

15. To find the Sine, Cosine, and Tangent of any Angle from the Tables.—The results of the last paragraph give us the method of finding the trigonometrical ratios of an angle of any size from tables which give the values of these ratios for angles between 0° and 90° .

Draw a figure showing how the angle is generated, and thus find in what quadrant the generating line OP lies; then look up in the tables the numerical values of the sine, cosine, and tangent for the acute angle which OP makes with $X'OX$, and before these place the proper signs as found in the last paragraph.

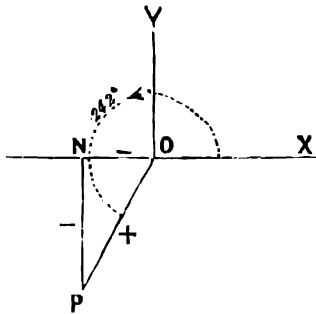

FIG. 6.

EXAMPLE (1).—To find from the tables the values of $\sin 242^\circ$ and $\tan 242^\circ$.

In the figure, OP is in the third quadrant.

$$\sin 242^\circ = \frac{-NP}{OP} = -\sin NOP = -\sin 62^\circ$$

$$= -0.8829 \text{ from the tables}$$

$$\tan 242^\circ = \frac{-NP}{-ON} = +\tan 62^\circ = 1.8807$$

EXAMPLE (2).—Find the value of $\cos (-200^\circ)$.

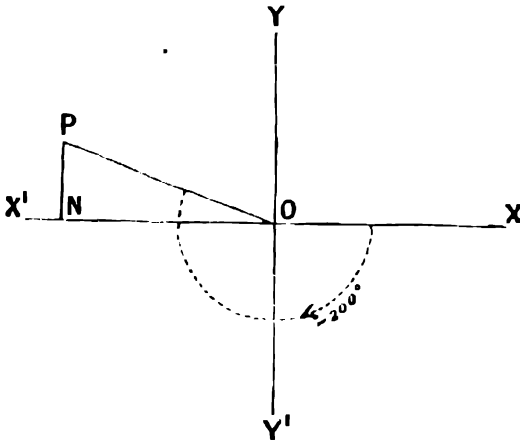

FIG. 7.

The generating line **OP** is in the second quadrant

$$\begin{aligned} \cos (-200^\circ) &= \frac{-\text{ON}}{\text{OP}} = -\cos \text{PON} \\ &= -\cos 20^\circ = -0.9397 \end{aligned}$$

When we require to find a trigonometrical ratio of an angle which lies between two consecutive angles in the tables, we assume that a small change in the ratio is proportional to the change in the angle, and proceed as follows :—

EXAMPLE (1).—To find $\sin 15.8^\circ$ from the tables.

We find from the tables

$$\begin{array}{r} \sin 16^\circ = 0.2756 \\ \sin 15^\circ = 0.2598 \\ \hline \end{array}$$

$$\text{difference for } 1^\circ = 0.0168$$

$$\therefore \text{ difference for } 0.8^\circ = 0.8 \times 0.0168 = 0.0134$$

Adding this to $\sin 15^\circ$, we get

$$\sin 15.8^\circ = 0.2722$$

EXAMPLE (2).—To find $\cos 221.4^\circ$.

We have $\cos 221.4^\circ = -\cos 41.4^\circ$.

From the tables

$$\begin{array}{r} \cos 41^\circ = 0.7547 \\ \cos 42^\circ = 0.7431 \\ \hline \end{array}$$

$$\text{Difference for } 1^\circ = 0.0116$$

$$\therefore \text{ difference for } 0.4^\circ = 0.00464$$

Since the cosine of an angle decreases as the angle increases, this difference must be subtracted from $\cos 41^\circ$.

$$\text{We get } \cos 41.4^\circ = 0.75006$$

$$\therefore \cos 221.4^\circ = -0.7501$$

A graphic method of finding the ratios of an angle which lies between two given values, by means of squared paper, will be given in Chapter VII.

EXAMPLE (3).—To find the angle between 0° and 90° whose sine is 0.6070 .

We find from the tables

$$\begin{array}{r} \sin 38^\circ = 0.6157 \\ \sin 37^\circ = 0.6018 \\ \hline \end{array}$$

$$\text{Difference for } 1^\circ = 0.0139$$

Thus the required angle lies between 37° and 38° .

$$\text{Let the required angle} = 37^\circ + x^\circ$$

$$\text{Then } \sin (37^\circ + x^\circ) = 0.6070$$

$$\sin 37^\circ = 0.6018$$

$$\text{Difference for } x^\circ = 0.0052$$

$$\therefore \frac{x}{1} = \frac{0.0052}{0.0139} = 0.374$$

$$\therefore \text{ the required angle is } 37.37^\circ.$$

16. Trigonometrical Ratios of Angles of Equal Numerical Magnitude but Opposite Sign.

Let OP and OP' make angles θ and $-\theta$ with OX .

Take $OP = OP' = r$.

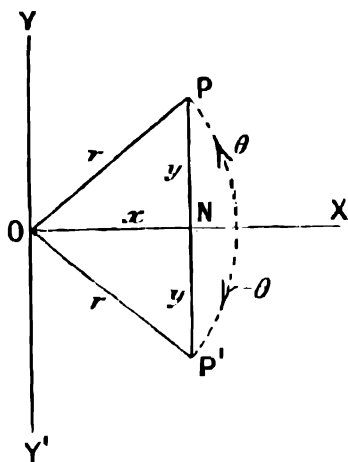

FIG. 8.

Then for the points P and P' the values of x and r are always the same, whatever the value of θ , while the values of y are of equal numerical magnitude but opposite sign.

$$\therefore \sin(-\theta) = \frac{NP'}{OP'} = \frac{-NP}{OP} = -\sin \theta$$

$$\cos(-\theta) = \frac{ON}{OP'} = \frac{ON}{OP} = +\cos \theta$$

$$\tan(-\theta) = \frac{NP'}{ON} = -\frac{NP}{ON} = -\tan \theta$$

An even power of any quantity does not change sign when that quantity changes sign, while an odd power of any quantity does change sign with that quantity. By analogy, we say that $\sin \theta$ and $\tan \theta$ are odd functions of θ , because they change sign when θ changes sign, while $\cos \theta$ is said to be an even function of θ because it does not change sign with θ .

17. Angles whose Generating Lines lie between Two Quadrants.

I. Ratios of 0° .

Let $XOP = \theta$ be a very small angle.

Then for the point P x is very nearly equal to r , and y is very small. Now let OP move down towards OX . Then, as θ gets nearer and nearer to the value 0° , x gets more and more nearly equal to r , and y gets more and more nearly equal to 0.

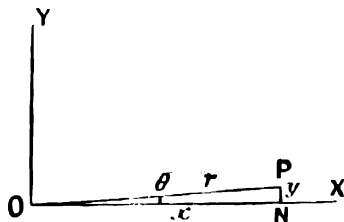

FIG. 9.

$$\therefore \cos \theta = \frac{x}{r} \text{ approaches the value } 1$$

and may be made as nearly equal to 1 as we please by taking θ small enough, while $\sin \theta = \frac{y}{r}$

and $\tan \theta = \frac{y}{x}$ approach the value 0 as θ diminishes.

Accordingly, although we cannot construct an angle of 0° , we may still say that

$$\sin 0^\circ = 0, \cos 0^\circ = 1, \tan 0^\circ = 0$$

II. Ratios of 90° .

Suppose OP to be approaching OY , so that $\theta = XOP$ is approaching the value 90° .

Then y is getting more and more nearly equal

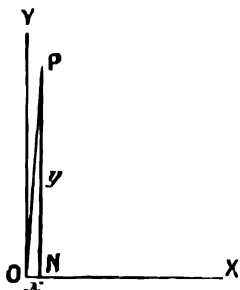

FIG. 10.

to r , so that $\sin \theta = \frac{y}{r}$ is approaching the value 1, so also x is getting more and more nearly equal to 0, and $\cos \theta = \frac{x}{r}$ is approaching the value 0.

Next consider the value of $\tan \theta = \frac{y}{x}$.

Suppose $y = 1$ and $x = \frac{1}{1,000,000}$, then $\tan \theta = 1,000,000$

Suppose $y = 1$ and $x = \frac{1}{10,000,000}$, then $\tan \theta = 10,000,000$

Suppose $y = 1$ and $x = \frac{1}{100,000,000}$, then $\tan \theta = 100,000,000$

and so on.

Thus by taking x small enough, and consequently θ sufficiently near to 90° , we can make $\tan \theta$ greater than any number that can be thought of. A quantity which is greater than any number that can be thought of is said to be infinite, and is denoted by the sign ∞ .

We thus get the results

$$\sin 90^\circ = 1, \cos 90^\circ = 0, \tan 90^\circ = \infty$$

III. Ratios of 180° .

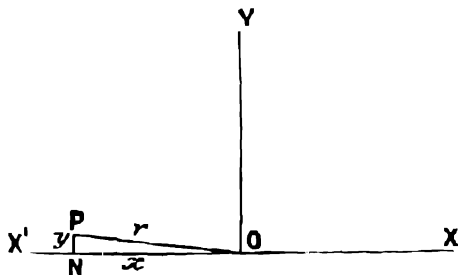

FIG. 11.

As OP approaches OX'—

and θ approaches the value 180°

and x " " $-r$

and y " " 0

\therefore as before we get

$$\sin 180^\circ = 0, \cos 180^\circ = \frac{-r}{r} = -1, \tan 180^\circ = 0$$

IV. Ratios of 270° .

As OP approaches OY', and θ approaches the value 270°

x approaches the value 0

and y " " $-r$

$$\text{and we get } \sin 270^\circ = \frac{-r}{r} = -1, \cos 270^\circ = 0$$

By proceeding as in the case of 90° we get, if we suppose OP to approach OY' from the third quadrant, $\tan 270^\circ = +\infty$.

We may here notice that if we suppose OP to approach OY from the

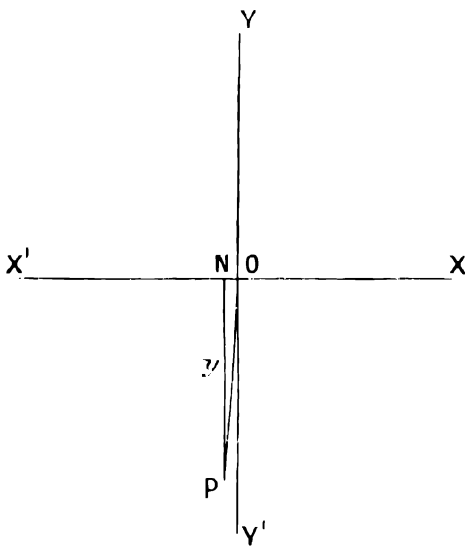

FIG. 12.

second quadrant in finding the value of $\tan 90^\circ$, the value of x is negative, and we get $\tan 90^\circ = -\infty$.

Thus the tangent of an angle gradually increases from 0 to ∞ as the angle increases from 0 to a right angle, and then makes a sudden change to $-\infty$ as the angle passes through the value 90° .

So also the tangent changes from $+\infty$ to $-\infty$ as the angle passes through the value 270° .

EXAMPLES.—IX.

Draw figures to show the angles in the following examples, and find from the tables the sine, cosine, and tangent of each :—

- | | |
|---|---|
| 1. 175° , 210° , 320° , 400° . | 2. 163° , 213° , 310° , 505° , 1200° . |
| 3. 159° , 238° , 294° , 516° . | 4. 163° , 210° , 100° , 200° , 300° . |
| 5. 23° , 123° , 233° , 312° , 383° . | 6. 113° , 211° , 265° , 293° , 310° . |
| 7. -73° , -160° , -250° , -403° . | 8. -131° , -283° , -791° . |

Find the values of the following :—

- | | |
|--|--|
| 9. $\sin 26.7^\circ$, $\cos 26.7^\circ$, $\tan 26.7^\circ$. | 10. $\sin 133.3^\circ$, $\cos 133.3^\circ$, $\tan 133.3^\circ$. |
| 11. $\sin 221.4^\circ$, $\cos 221.4^\circ$, $\tan 221.4^\circ$. | 12. $\sin 311.2^\circ$, $\cos 311.2^\circ$, $\tan 311.2^\circ$. |
| 13. $\sin 121.2^\circ$, $\sin 212.6^\circ$, $\sin (-82^\circ)$. | |

14. Give the values in degrees, correct to one-tenth of a degree, of the following :—
 $\sin^{-1} 0.2147$, $\sin^{-1} 0.8634$, $\cos^{-1} 0.3859$, $\tan^{-1} 1.2985$.

15. Find the values of the following expressions ; the angles are given in radians :—

$$\tan \frac{5\pi}{6}, \sin 2.53, \cos 5, \cos 3.42, \sin (-1.571), \cot (-2.34)$$

16. Find the values of $\cos(3x - 1)$ for the cases where $x = 1$ radian, and $x = 5$ radians respectively.

17. Find the value of $\sin(ct + g)$, where $c = 600$, $t = 0.1$, $g = -0.1745$, and the angle $(ct + g)$ is expressed in radians.

18. Find the value of $\sin(ct + g)$ where $c = 400$, $t = 0.01$, $g = 1.1170$.

19. Construct angles of 2 and 3 radians, and find from the tables their sines, cosines, and tangents.

18. Complementary Angles.—If the sum of two angles is a right angle they are said to be complementary angles, and each is called the complement of the other.

To find the relation between the ratios of an angle and of its complement.

Let $\text{XOP} = \theta$ be any acute angle. Then in the figure

$$\text{NOP} + \text{OPN} = 90^\circ$$

and OPN is the complement of θ .

Accordingly we shall get the values of the ratios of the complement of θ by interchanging x and y in the values of the ratios of θ given in the definitions on p. 11.

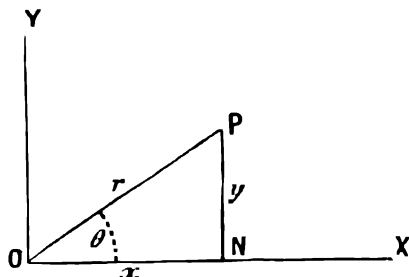

FIG. 13.

$$\sin(90^\circ - \theta) = \sin \text{OPN} = \frac{x}{r} = \cos \theta$$

$$\cos(90^\circ - \theta) = \cos \text{OPN} = \frac{y}{r} = \sin \theta$$

$$\tan(90^\circ - \theta) = \tan \text{OPN} = \frac{x}{y} = \cot \theta$$

$$\sec(90^\circ - \theta) = \sec \text{OPN} = \frac{r}{y} = \text{cosec } \theta$$

These results may be expressed in the statement—

Any ratio of an angle is equal to the co-ratio of its complement.

This property of complementary angles is made use of in the tables. Each angle between 0° and 45° on the left-hand side is opposite to its complement on the right-hand side, so that the column for any ratio of angles from 0° to 45° will also serve for the co-ratio of angles from 45° to 90° ; e.g. the column of sines for angles from 0° to 45° is the same as the column of cosines for angles from 45° to 90° , thus 0.4848 stands as $\sin 29^\circ$ and also as $\cos 61^\circ$.

This property of complementary angles may also be proved for angles of any size. As an example the student should prove it for the case of angles between 90° and 180° .

19. Supplementary Angles.—If the sum of two angles is 180° they are said to be supplementary angles, and each angle is called the supplement of the other.

To find the relation between the ratios of an angle and of its supplement.

If OP generates an angle θ , the supplement of θ which is equal to $180^\circ - \theta$, will be generated by a straight line OQ , rotating, first from OX to OX' ,

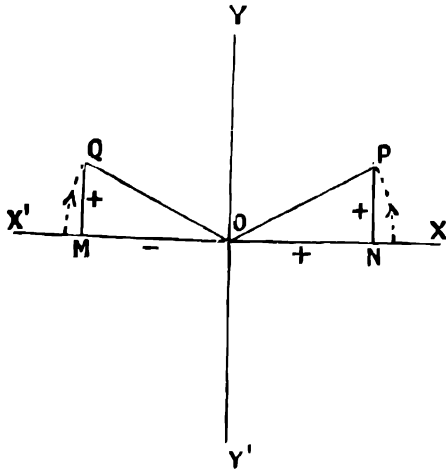

FIG. 14.

through an angle of 180° in a positive direction and then backwards through an angle $X'OQ = \theta$ in a negative direction, so that XOQ is the supplement of θ .

Thus, as OP starts from OX to generate the angle θ , OQ starts at the same instant from OX' , and the two lines rotate round O in opposite directions at the same rate, crossing each other at OY and OY' .

It follows that whatever the value of θ the values of y and r are the same for the two points P and Q , while the values of x are numerically equal, but of opposite sign.

$$\begin{aligned} \therefore \sin (180^\circ - \theta) &= \frac{MQ}{OQ} = \frac{NP}{OP} = \sin \theta \\ \cos (180^\circ - \theta) &= \frac{OM}{OQ} = -\frac{ON}{OP} = -\cos \theta \\ \tan (180^\circ - \theta) &= \frac{MQ}{OM} = -\frac{NP}{ON} = -\tan \theta \end{aligned}$$

Note in particular that—

The sine of an angle is the same as the sine of its supplement ;

The cosine of an angle is equal in numerical magnitude but opposite in sign to the cosine of its supplement.

20. Formulæ connecting the Ratios of an Angle.

From the definitions of the trigonometrical ratios we get the following relations :—

$$\sec \theta = \frac{r}{x} = \frac{1}{\frac{x}{r}} = \frac{1}{\cos \theta} \dots \dots \dots (1)$$

$$\operatorname{cosec} \theta = \frac{r}{y} = \frac{1}{\frac{y}{r}} = \frac{1}{\sin \theta} \quad \dots \dots \dots (2)$$

$$\cot \theta = \frac{x}{y} = \frac{1}{\frac{y}{x}} = \frac{1}{\tan \theta} \quad \dots \dots \dots (3)$$

$$\frac{\sin \theta}{\cos \theta} = \frac{\frac{y}{r}}{\frac{x}{r}} = \frac{y}{x} = \tan \theta \quad \dots \dots \dots (4)$$

EXAMPLE (1).—To verify from the tables that $\cot 56^\circ = \frac{1}{\tan 56^\circ}$

Examples in the verification of these formulæ are given in order to fix them in the mind of the student. The details of the calculation should be set down in full, as in this example, so that the student may obtain a knowledge of the limits of accuracy in working with four-figure tables.

From the tables we get $\tan 56^\circ = 1.4826$.

$$\begin{aligned} \log 1.4826 &= 0.1711 \\ \log 1 &= 0.0 \end{aligned}$$

$$\therefore \log \frac{1}{1.4826} = 1.8289 = \log 0.6744$$

The tables give $\cot 56^\circ = 0.6745$

$$\therefore \cot 56^\circ = \frac{1}{\tan 56^\circ}$$

within the limits of accuracy of the tables.

EXAMPLE (2).—Verify from the tables that $\frac{\sin 31^\circ}{\cos 31^\circ} = \tan 31^\circ$.

From the tables

$$\sin 31^\circ = 0.5150; \quad \log 0.5150 = 1.7118$$

$$\cos 31^\circ = 0.8572; \quad \log 0.8572 = 1.9331$$

$$\therefore \log \frac{0.5150}{0.8572} = 1.7787 = \log 0.6008$$

From the tables $\tan 31^\circ = 0.6009$

$$\therefore \frac{\sin 31^\circ}{\cos 31^\circ} = \tan 31^\circ$$

EXAMPLE (3).—To find the angle whose tangent is 82.7 correct to one-tenth of a degree.

The angle is evidently between 89° and 90° , but cannot be found directly from the tables since $\tan 90^\circ = \infty$.

We know, however, that, if x° be the required angle,

$$\tan (90^\circ - x^\circ) = \cot x = \frac{1}{\tan x} = 0.0121$$

The tangent of a small angle is very nearly proportional to the angle, and therefore we may find the tangent of $(90^\circ - x^\circ)$ from the tables.

We have $\tan 1^\circ = 0.0175$
 $\therefore 90^\circ - x^\circ = \frac{0.0121}{0.0175} = 0.69^\circ$
 $\therefore x = 89.3^\circ$

21. In Fig. 13, p. 19, we have by elementary geometry, since ONP is a right angle,

$$x^2 + y^2 = r^2 \dots \dots \dots (5)$$

Dividing by r^2 we get

$$\frac{x^2}{r^2} + \frac{y^2}{r^2} = 1$$

$$\therefore \cos^2 \theta + \sin^2 \theta = 1 \dots \dots \dots (6)$$

Dividing (5) by x^2 we get

$$1 + \frac{y^2}{x^2} = \frac{r^2}{x^2}$$

$$\therefore 1 + \tan^2 \theta = \sec^2 \theta \dots \dots \dots (7)$$

Dividing (5) by y^2 we get

$$\frac{x^2}{y^2} + 1 = \frac{r^2}{y^2}$$

$$\therefore \cot^2 \theta + 1 = \operatorname{cosec}^2 \theta \dots \dots \dots (8)$$

EXAMPLE (1).—To verify the formula (6) for the case when $\theta = 40^\circ$.

We find from the tables

$$\sin 40^\circ = 0.6428 ; \cos 40^\circ = 0.7660$$

$$\therefore \sin^2 \theta + \cos^2 \theta = (0.6428)^2 + (0.7660)^2$$

$$= 0.4130 + 0.5866$$

$$= 0.9996$$

$$= 1 \text{ to an accuracy of } 0.05 \%$$

By means of these formulæ, if one ratio of an angle is given, all the others can be found.

EXAMPLE (2).—Given $\sin \theta = 0.2$: find $\cos \theta$ and $\tan \theta$. We shall assume that θ is less than 90° .

We have by (6) $\sin^2 \theta + \cos^2 \theta = 1$

$$\therefore \cos^2 \theta = 1 - \sin^2 \theta = 1 - (0.2)^2 = 1 - 0.04 = 0.96$$

$$\therefore \cos \theta = \sqrt{.96} = 0.98$$

$$\text{and } \tan \theta = \frac{\sin \theta}{\cos \theta} = \frac{0.2}{0.98} = 0.204$$

We may also proceed as follows :—

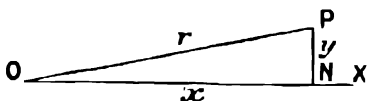

FIG. 13.

Draw the triangle OPN so that OP = $r = 1$, and PN = 0.2 , to any convenient scale, and ONP is a right angle.

Then $\sin \theta = \frac{PN}{OP} = 0.2$
 $\therefore \theta = \sin^{-1} 0.2$
 and since $x^2 + y^2 = r^2$
 $x^2 = r^2 - y^2 = 1 - 0.04 = 0.96$
 $\therefore x = \sqrt{0.96} = 0.98$

$$\text{and } \cos \theta = \frac{x}{r} = 0.98$$

$$\tan \theta = \frac{y}{x} = \frac{0.2}{0.98} = 0.204$$

If $\tan \theta$ is given in the first instance, we may find $\sec \theta$ from the formula (7); $\cos \theta$ is then given by (1), and $\sin \theta$ by (4).

EXAMPLES.—X.

1. Verify from the tables that $\sin^2 \theta + \cos^2 \theta = 1$ for the case when $\theta = 49^\circ$.
2. Verify by numerical calculation that $\frac{\sin 23^\circ}{\cos 23^\circ} = \tan 23^\circ$.
3. Verify that $1 + \tan^2 25^\circ = \sec^2 25^\circ$.
4. Verify that $\cot 55^\circ = \frac{1}{\tan 55^\circ}$.
5. Verify that $1 + \cot^2 \theta = \operatorname{cosec}^2 \theta$ for the case when $\theta = 25^\circ$.
6. The sine of an angle is 0.3; construct the angle, and find its cosine and tangent.
7. The cosine of an angle is 0.25; find its sine and tangent.
8. The tangent of an angle is 2; find its sine and cosine.
9. $\sin \theta = 0.5341$; find $\cos \theta$ and $\tan \theta$.
10. $\cos \theta = 0.4746$; find $\sin \theta$ and $\tan \theta$.
11. $\sec \theta = 7.9604$; find $\sin \theta$, $\cos \theta$, and $\tan \theta$.
12. Construct an angle whose tangent is $\frac{3}{4}$, and find its sine and cosine.
13. $\sin \theta = 0.350$; find $\cos \theta$ and $\tan \theta$.
14. Construct an angle whose sine is $\frac{5}{13}$, and find its cosine and tangent.
15. Construct an angle whose tangent is $\frac{2}{3}$, and find its sine and cosine.
16. Construct an angle whose secant is $\frac{3}{2}$, and find its sine, cosine, and tangent.
17. Construct an angle whose cosine is $\frac{1}{3}$, and find its sine and tangent.
18. Construct an angle whose tangent is $\frac{7}{4}$, and find its cosine and sine.
19. Construct an angle whose cotangent is $\frac{4}{3}$, and find its sine and cosine.
20. If $\tan \phi = \frac{y}{x}$, find $\sin \phi$ and $\cos \phi$.
21. If $x^2 + y^2 + z^2 = r^2$, and $\cos \theta = \frac{z}{r}$, find $\sin \theta$ and $\tan \theta$ in terms of x , y , and z .

CHAPTER III

SOLUTION OF TRIANGLES

22. A triangle may be considered as made up of three sides and three angles. These are called the six parts of the triangle. When any three of the six parts are given, one given part being a side, the triangle can be constructed and the remaining parts found. The process of finding the remaining parts when three are given is sometimes spoken of as solving the triangle.

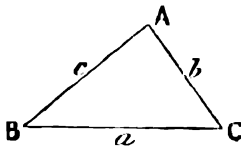

FIG. 16.

We use **A, B, C** to denote the angles of the triangle **ABC**, and *a, b, c* to denote the sides opposite to the angles denoted by the corresponding letters; thus *a* denotes the side **BC** opposite to the angle **A**.

23. **Solution of Right-angled Triangles.**—If it is known that one of the angles, **C**, is a right angle, this part of the triangle is known, and we require to know two other parts, one of which must be a side, in order to solve the triangle.

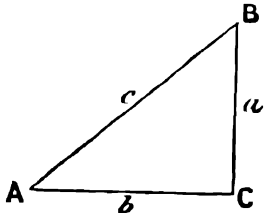

FIG. 17.

I. Let one of the angles, and one of the sides containing the right angle, be given as **A, a**.

Then we have

$$\begin{aligned} \mathbf{A + B + C} &= 180^\circ, \text{ and } \mathbf{C} = 90^\circ \\ \therefore \mathbf{A + B} &= 90^\circ, \text{ and } \mathbf{B} = 90^\circ - \mathbf{A} \end{aligned}$$

Thus **B** is determined.

$$\text{Also } \frac{b}{a} = \cot \mathbf{A}, \text{ and } \therefore b = a \cot \mathbf{A}$$

Thus **b** is determined.

To find **c** we have $\frac{a}{c} = \sin \mathbf{A}$, and $\therefore c = \frac{a}{\sin \mathbf{A}}$, and **c** is determined.

EXAMPLE.—Let **a** = 2.7 ft., **B** = 54°. Solve the triangle.

We have **A + B** = 90°; $\therefore \mathbf{A} = 90^\circ - \mathbf{B} = 36^\circ$

$$\frac{b}{a} = \tan \mathbf{B}; \therefore b = a \tan \mathbf{B} = 2.7 \tan 54^\circ = 2.7 \times 1.376 = 3.715 \text{ ft.}$$

$$\text{Also } \frac{a}{c} = \sin \mathbf{A}; \therefore c = \frac{a}{\sin \mathbf{A}} = \frac{2.7}{0.588} = 4.59 \text{ ft.}$$

$$\therefore \mathbf{A} = 36^\circ, b = 3.715 \text{ ft., } c = 4.59 \text{ ft.}$$

The student should draw the triangle **ABC** to scale from the given data, and find the values of **b, c,** and **A** by measurement.

II. Let one of the angles and the hypotenuse be given as A, c .
Then, as before, $B = 90^\circ - A$.

$$\frac{b}{c} = \cos A \quad \therefore b = c \cos A$$

$$\frac{a}{c} = \sin A \quad \therefore a = c \sin A$$

Thus $B, b,$ and a are determined.

EXAMPLE.—Let $c = 3.4$ ft., $B = 29^\circ$. Solve the triangle.

We have $A = 90^\circ - B = 61^\circ$

$$a = c \cos B = c \cos 29^\circ = 3.4 \times 0.8746 = 2.975 \text{ ft.}$$

$$b = c \sin B = c \sin 29^\circ = 3.4 \times 0.4848 = 1.649 \text{ ft.}$$

$$\therefore A = 61^\circ, a = 2.975 \text{ ft., } b = 1.649 \text{ ft.}$$

The student should verify these results by construction and measurement.

III. Let the two sides containing the right angle be given as a, b .

$$\text{Then } \tan A = \frac{a}{b}$$

$$B = 90^\circ - A$$

$$\frac{a}{c} = \sin A, \text{ and } c = \frac{a}{\sin A}$$

$$\text{or } c = \sqrt{a^2 + b^2}$$

Thus $A, B,$ and c are determined.

EXAMPLE.—Let $a = 3.4$ ft., $b = 2.6$ ft. Solve the triangle.

$$\tan A = \frac{a}{b} = \frac{3.4}{2.6} = 1.307 = \tan 52.5^\circ$$

$$\therefore A = 52.5^\circ; B = 90^\circ - 52.5^\circ = 37.5^\circ$$

$$c = \sqrt{a^2 + b^2} = \sqrt{3.4^2 + 2.6^2} = 4.28 \text{ ft.}$$

$$\therefore A = 52.5^\circ, B = 37.5^\circ, c = 4.28 \text{ ft.}$$

Verify by construction and measurement.

IV. Let the hypotenuse and one other side be given as c, a .

$$\text{Then } \sin A = \frac{a}{c}$$

$$B = 90^\circ - A$$

$$\frac{b}{c} = \sin B \quad \therefore b = c \sin B$$

$$\text{or } a^2 + b^2 = c^2 \quad \therefore b = \sqrt{c^2 - a^2}$$

Thus $A, B,$ and b are determined.

EXAMPLE.—Let $c = 5.4$ ft., $b = 2.6$ ft. Solve the triangle.

$$\text{We have } \sin B = \frac{b}{c} = \frac{2.6}{5.4} = 0.4815 = \sin 28.8^\circ, \text{ and } \therefore B = 28.8^\circ$$

$$A = 90^\circ - 28.8^\circ = 61.2^\circ$$

$$a = \sqrt{c^2 - b^2} = \sqrt{29.16 - 6.76} = 4.73 \text{ ft.}$$

$$\therefore B = 28.8^\circ, A = 61.2^\circ, a = 4.73 \text{ ft.}$$

Verify by construction and measurement.

EXAMPLES.—XI.

ABC is a triangle having a right angle at **C**. Solve the triangle, having given the following data. In each case verify your result by construction and measurement.

1. $A = 32^\circ$; $a = 1.7$ ft.

2. $A = 56^\circ$; $b = 3.8$ ft.

3. $B = 49^\circ$; $c = 2.7$ ft.

4. $b = 3.4$ ins.; $a = 2.7$ ins.

5. $b = 55$ ins.; $c = 167$ ins.

6. $a = 32$ ins.; $c = 98$ ins.

24. The Sides of a Triangle are Proportional to the Sines of the Opposite Angles.

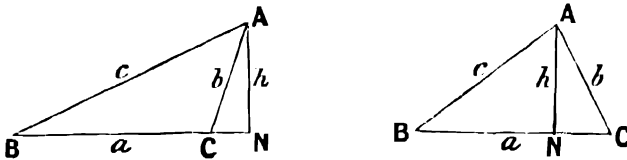

FIG. 18.

In the triangle **ABC** draw **AN** perpendicular to **BC** or **BC** produced. Then in both figures

$$\sin B = \frac{AN}{c}; \sin C = \frac{AN}{b}$$

$$\therefore \text{dividing we get } \frac{\sin B}{\sin C} = \frac{\frac{AN}{c}}{\frac{AN}{b}} = \frac{b}{c}$$

Similarly, by dropping a perpendicular from **B** on **AC**, we may prove that

$$\frac{\sin C}{\sin A} = \frac{c}{a}$$

and similarly $\frac{\sin A}{\sin B} = \frac{a}{b}$

Thus the sides of a triangle are proportional to the sines of the opposite angles; or

$$\frac{a}{\sin A} = \frac{b}{\sin B} = \frac{c}{\sin C} \dots \dots \dots (1)$$

EXAMPLE.—To verify the formula 1. numerically.

Let $b = 2$, $c = 3$. With any point **A** as centre, describe two circles of radii 3 and 2. Draw any straight line **DE** to cut the circles in **B** and **C** respectively. Join **AB** and **AC**.

Measure the angles at **B** and **C**, and calculate the ratio $\frac{\sin B}{\sin C}$. Compare this with the ratio $\frac{b}{c} = \frac{2}{3}$.

Then draw the straight line **DE** in another position, so that it still cuts the two circles. Find $\frac{\sin B}{\sin C}$ as before, and compare with the ratio $\frac{b}{c}$.

In an actual case it was found

$$\begin{aligned}
 & B = 34^\circ; C = 56.4^\circ \\
 \therefore \frac{\sin B}{\sin C} &= \frac{\sin 34^\circ}{\sin 56.4^\circ} = \frac{0.5592}{0.8329} = 0.67 \\
 \text{while } \frac{b}{c} &= \frac{3}{4} = 0.666 \dots
 \end{aligned}$$

Similarly, by drawing DE in other positions, so that B and C are on the re-

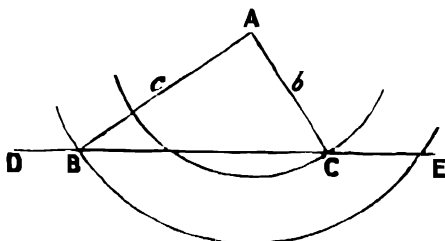

FIG. 19.

spective circles, and therefore b and c have always the same values, we find that $\frac{\sin B}{\sin C}$ is always equal to $\frac{b}{c}$ within the limits of experimental error in drawing.

This formula may be used in the following cases of solution of triangles.

25. I. Given two angles and a side as B, C, b .

Since $A + B + C = 180^\circ$, $A = 180^\circ - B + C$, and is determined.

We now know all three angles.

To find c we have

$$\frac{c}{b} = \frac{\sin C}{\sin B} \quad \therefore c = b \frac{\sin C}{\sin B}$$

and can be calculated, since all quantities on the right-hand side of this equation are known.

To find a we have

$$\frac{a}{b} = \frac{\sin A}{\sin B} \quad \therefore a = \frac{b \sin A}{\sin B}$$

We have now expressed A, c , and a , in terms of known quantities.

EXAMPLE.—In the triangle ABC given, $B = 49^\circ, C = 63^\circ, b = 36.3$. Find A, c , and a .

In this and subsequent examples the logarithmic working has been shown in full, as an example to the student of how his work should be set down.

$$\begin{aligned}
 \text{Since } A + B + C &= 180^\circ \\
 A &= 180^\circ - (B + C) = 180^\circ - (49^\circ + 63^\circ) = 68^\circ
 \end{aligned}$$

To find a we have

$$\frac{a}{b} = \frac{\sin A}{\sin B}; \quad a = \frac{b \sin A}{\sin B} = \frac{36.3 \sin 68^\circ}{\sin 49^\circ} = \frac{36.3 \times 0.9272}{0.7547}$$

$$\log 36.3 = 1.5599$$

$$\log 0.9272 = 1.9672$$

$$\log 0.7547 = 1.8778$$

$$\log a = 1.6493 = \log 44.60$$

$$\therefore a = 44.6$$

To find c we have

$$\frac{c}{b} = \frac{\sin C}{\sin B} \quad \therefore c = \frac{b \sin C}{\sin B} = \frac{36.3 \sin 63^\circ}{\sin 49^\circ} = \frac{36.3 \times 0.8910}{0.7547}$$

$$\log 36.3 = 1.5599$$

$$\log 0.8910 = 1.9499$$

$$\log 0.7547 = 1.8778$$

$$\log c = 1.6320 = \log 42.85$$

$$\therefore c = 42.85$$

Thus the required values are

$$A = 68^\circ, c = 42.85, a = 44.6$$

The student should construct the triangle from the given values, and find the values of a and b by measurement.

The percentage error of the measured as compared with the calculated value should be found and stated.

28. II. Given two sides and the angle opposite one of them, as b, c, B .

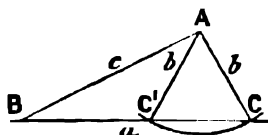

FIG. 20.

Draw AB equal to the given value of c .

Make the angle ABC equal to B . With centre A and radius equal to the given value of b describe a circle. This will in general cut BC in two points, C, C' .

If b is less than c , these points are both on the same side of B . Join AC, AC' .

Thus there are two possible triangles, ABC, ABC' , having the given values of b, c , and B .

If b is greater than c , only one of the points of intersection, C , is on the same side of B as the given angle ABC .

In this case there is only one triangle satisfying the given conditions.

If the circle of radius b touches BC the two triangles ABC and ABC' coincide, and we have a right-angled triangle ABC .

If we find that b is shorter than the perpendicular from A to BC , the circle will not reach the line BC , and there is no possible triangle having the given values of b, c , and B .

Whenever two sides and the angle opposite one of them are given, the student should first draw the figure to scale; he will then see what solutions to look for.

To solve the triangle by calculation we proceed as follows:—

$$\frac{\sin C}{\sin B} = \frac{c}{b} \quad \therefore \sin C = \frac{c \sin B}{b}$$

Since c , b , and $\sin B$ are known, this gives $\sin C$. Since angles in both the first and second quadrants have their sines positive, this value of $\sin C$ may correspond to either of two values of C , one the acute angle ACB , and the other its supplement, $AC'B$.

In Fig. 20, for example, we should find from the tables the value of ACB corresponding to the value of $\sin C$, but the angle $AC'B$, which is the supplement of ACB , has the same sign, and is a possible solution. The figure will always show what values to take.

Taking first the acute angle ACB as the value of C , we now have

$$A = 180^\circ - (B + C)$$

The side BC may now be found from the formula

$$\frac{a}{b} = \frac{\sin A}{\sin B} \quad \therefore a = \frac{b \sin A}{\sin B}$$

We have now found all the parts of the triangle ABC .

Similarly, taking the obtuse angle $AC'B$ as the value of C , we may solve the triangle $AC'B$.

EXAMPLE (1).—In the triangle ABC , given $b = 5.631$, $c = 4.732$, $B = 47^\circ$, find C .

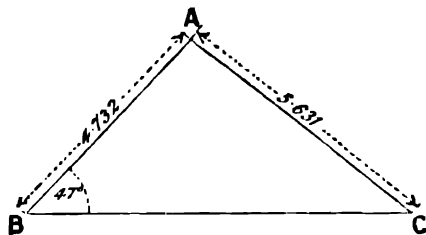

FIG. 21.

By construction we find that there is only one possible solution.

$$\begin{aligned} \text{We have } \frac{\sin C}{\sin B} &= \frac{c}{b} \\ \therefore \sin C &= \frac{c \sin B}{b} = \frac{4.732 \times 0.7314}{5.631} \end{aligned}$$

$$\log 4.732 = 0.6751$$

$$\log 0.7314 = 1.8641$$

$$\log 5.631 = 0.7506$$

$$\log \sin C = 1.7886 = \log 0.6146$$

$$\therefore \sin C = 0.6146$$

$$\sin 37^\circ = 0.6018$$

$$\text{difference} = 0.0128$$

$$\sin 38^\circ = 0.6157$$

$$\sin 37^\circ = 0.6018$$

$$\text{difference for } 1^\circ = 0.0139$$

$$\therefore C = (37 + \frac{128}{139})^\circ = 37.9^\circ$$

Verify by construction and measurement.

EXAMPLE (2).—Given $a = 25.2$, $b = 31.6$, $A = 23^\circ$, find B and C .

By construction we see that there are two possible solutions,

$$\begin{aligned} \text{We have } \frac{\sin B}{\sin A} &= \frac{b}{a} \\ \therefore \sin B &= \frac{b \sin A}{a} = \frac{31.6 \times 0.3907}{25.2} \end{aligned}$$

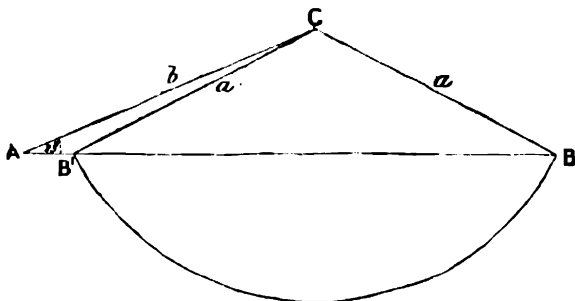

FIG. 22.

$$\begin{aligned} \log 31.6 &= 1.4997 \\ \log 0.3907 &= 1.5919 \\ \hline &= 1.0916 \\ \log 25.2 &= 1.4014 \\ \hline \log \sin B &= 1.6902 = \log 0.4900 \\ \therefore \sin B &= 0.4900 = \sin 29.3^\circ \\ \text{and } B &= 29.3^\circ \end{aligned}$$

This is the angle $CBA = CB'A$ in the figure.

$$\therefore CB'A = 180^\circ - CB'B = 180^\circ - 29.3^\circ = 150.7^\circ$$

and the possible values of B are 29.3° and 150.7° .

If $B = 29.3^\circ$, $C = 180^\circ - (A + B) = 127.7^\circ = \angle ACB$

If $B = 150.7^\circ$, $C = 180^\circ - (A + B) = 6.3^\circ = \angle ACB'$

Compare these results with the values found by construction and measurement.

EXAMPLES.—XII.

Solve the triangle ABC completely when the following data are given:—

- $A = 28^\circ$, $B = 35^\circ$, $c = 6$.
- $A = 58^\circ$, $B = 73^\circ$, $b = 3.42$
- $A = 75^\circ$, $B = 43^\circ$, $b = 5.462$ yds.
- $A = 85^\circ$, $B = 42^\circ$, $a = 4.65$.

Given—

- $b = 5.631$, $c = 4.732$, $B = 47^\circ$, find C .
- $c = 351$ ft., $b = 432$ ft., $B = 39^\circ$, find A and C .
- $a = 125.2$, $b = 131.6$, $A = 23^\circ$, find B and C .
- $a = 29.1$, $b = 30.2$, $A = 26^\circ$, find B and C .
- $a = 12.2$, $b = 16.1$, $A = 39^\circ$, find B and C .
- $a = 3.471$, $b = 2.689$, $A = 21^\circ$, find B , C , and c .

11. $a = 3.21$, $b = 2.65$, $B = 31^\circ$, find A , C , and c .
 12. $a = 256$ ft., $A = 64^\circ$, $B = 31^\circ$, find b and c .
 13. $a = 3$, $b = 4$, $A = 32^\circ$, find B , C , and c .

Solve the triangles in which

14. $a = 2.561$, $c = 3.261$, $A = 41^\circ$.
 15. $A = 120^\circ$, $C = 29^\circ$, $b = 252$ yds.
 16. $a = 35.6$, $b = 47.2$, $B = 55^\circ$.

Given—

17. $a = 2.71$, $c = 3.75$, $C = 64^\circ$, find b and A .
 18. $a = 2.1$, $b = 3.4$, $A = 32^\circ$, find B and C .
 19. $b = 4.61$, $c = 3.74$, $C = 41^\circ$, find A and B .

$$27. c^2 = a^2 + b^2 - 2ab \cos C.$$

In the triangle ABC let two sides a and b , and the angle C between them, be given. To find the remaining side c .

Draw BN perpendicular to AC .

I. Let the angles A and C be acute.

Then, since BNA is a right angle,

$$\begin{aligned} AB^2 &= BN^2 + NA^2 = BN^2 + (AC - CN)^2 \\ &= BN^2 + CN^2 + AC^2 - 2AC \cdot CN \\ &= BC^2 + AC^2 - 2AC \cdot CN \end{aligned}$$

But $AB = c$; $BC = a$; $AC = b$

and $\frac{CN}{BC} = \cos C$; $\therefore CN = a \cos C$

$$\therefore \text{substituting } c^2 = a^2 + b^2 - 2ab \cos C \dots \dots \dots (II.)$$

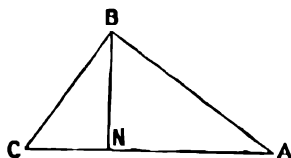

FIG. 23.

II. Let the angle C be obtuse.

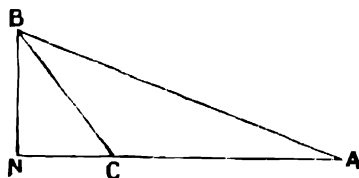

FIG. 24.

$$\begin{aligned} AB^2 &= BN^2 + AN^2 = BN^2 + (AC + CN)^2 \\ &= BC^2 + AC^2 + 2AC \cdot CN \end{aligned}$$

But $CN = a \cos BCN = a \cos (180^\circ - C) = -a \cos C$ (§ 19).

\therefore substituting $c^2 = a^2 + b^2 - 2ab \cos C$

A simpler proof of this formula will be given in Chapter XXI., on Vector Algebra. Similarly, we may prove that

$$\begin{aligned} a^2 &= b^2 + c^2 - 2bc \cos A \\ \text{and } b^2 &= c^2 + a^2 - 2ca \cos B \end{aligned}$$

If the three sides of a triangle are given, we may use these formulæ to find the angles; e.g. from I. we have

$$\cos C = \frac{a^2 + b^2 - c^2}{2ab}$$

EXAMPLE (1).—Given $a = 3.412$, $b = 2.735$, $C = 55^\circ$, find c .

$$c^2 = a^2 + b^2 - 2ab \cos C \\ = (3.412)^2 + (2.735)^2 - 2 \times 3.412 \times 2.735 \times 0.5736$$

$$\log 3.412 = 0.5331$$

$$\log 2.735 = 0.4370$$

$$\log (3.412)^2 = 1.0662 = \log 11.65$$

$$\log (2.735)^2 = 0.8740 = \log 7.482$$

$$\log 3.412 = 0.5331$$

$$\log 2.735 = 0.4370$$

$$\log 2 \times 0.5736 = \log 1.1472 = 0.0596$$

$$\log 2ab \cos C = 1.0297 = \log 10.71$$

$$\therefore c^2 = 11.65 + 7.482 - 10.71 = 8.422$$

$$c = \sqrt{8.422}$$

$$\log 8.422 = 0.9254$$

$$\log \sqrt{8.422} = 0.4627 = \log 2.902$$

$$\therefore c = 2.902$$

Compare this with the value obtained by construction and measurement.

EXAMPLE (2).—Given $a = 10$, $b = 5$, $c = 5.86$, find the angles.

$$\text{We have } c^2 = a^2 + b^2 - 2ab \cos C$$

$$\cos C = \frac{a^2 + b^2 - c^2}{2ab} = \frac{10^2 + 5^2 - 5.86^2}{2 \cdot 10 \cdot 5}$$

$$= \frac{100 + 25 - 34.34}{100} = 0.9066 = \cos 25^\circ$$

$$\therefore C = 25^\circ$$

To find B when C has been found, it is better to use the sine formula I., as it is more suitable for calculation with logarithms.

$$\text{We have } \frac{\sin B}{\sin C} = \frac{b}{c}$$

$$\therefore \sin B = \frac{b \sin C}{c} = \frac{5 \times 0.4226}{5.86}$$

$$= \frac{2.1130}{5.86} = 0.3606 = \sin 21.1^\circ$$

$$\therefore B = 21.1^\circ$$

$$A = 180^\circ - (B + C) = 180^\circ - 46.1^\circ = 133.9^\circ$$

\therefore the required angles are

$$A = 133.9^\circ, B = 21.1^\circ, C = 25^\circ$$

Compare with the values obtained by construction and measurement, and find the percentage errors.

Note that the error of the graphic method is often considerable with small angles, especially with angles less than 30° .

EXAMPLES.—XIII.

- $a = 3.2$, $b = 4.31$, $C = 56^\circ$; find c .
- $a = 3$, $b = 5$, $C = 42^\circ$; find c , A , and B .
- $a = 1.3$, $b = 4.5$, $C = 157.5$; find A and c .
- $a = 3.412$, $b = 2.735$, $C = 55^\circ$; find c .

5. $a = 2.793$, $b = 3.746$, $C = 71^\circ$; find c .
6. $a = 4.356$, $b = 6.231$, $C = 42^\circ$; find c .
7. $a = 5.634$, $c = 2.718$, $B = 69^\circ$; find b .
8. $b = 346.1$ ft., $c = 200$ ft., $A = 60^\circ$; find a .
9. $b = 2.31$, $c = 4.32$, $A = 37^\circ$; find a .
10. $a = 5.62$, $b = 3.71$, $C = 65^\circ$; find c .
11. $b = 322$ yds., $c = 254$ yds., $A = 53^\circ$; find a .
12. $b = 331$ yds., $c = 567$ yds., $A = 76^\circ$; find a .
13. $a = 5$, $b = 4$, $C = 59^\circ$; find B and A .
14. $a = 3.6$, $b = 2.5$, $c = 4.9$; find the angles.
15. $a = 5$, $b = 7$, $c = 9$; find A .
16. $a = 51$ yds., $b = 62$ yds., $C = 72^\circ$; find c .
17. $a = 2$, $b = 3$, $c = 4$; find the angles.
18. $a = 5.32$, $b = 3.74$, $c = 4.36$; find the angles.
19. $a = 31$ ft., $b = 42$ ft., $C = 62^\circ$; find c .

20. Area of a Triangle.—To find the area of a triangle in terms of any two sides and the angle between them.

Let a , b , and C be given.
Draw BN perpendicular to AC .

$$\text{Then } \frac{BN}{a} = \sin C, \text{ and } BN = a \sin C$$

$$\begin{aligned} \text{Area of triangle} &= \frac{1}{2} (\text{base} \times \text{height}) \\ &= \frac{1}{2} \cdot b \cdot BN \\ &= \frac{1}{2} b \cdot a \sin C = \frac{1}{2} ab \sin C \end{aligned}$$

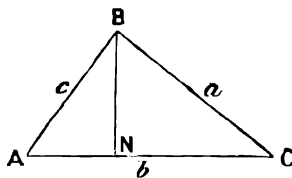

FIG. 25.

Similarly it can be proved that

$$\begin{aligned} \text{Area of triangle} &= \frac{1}{2} bc \sin A = \frac{1}{2} ca \sin B \\ &= \left\{ \begin{array}{l} \frac{1}{2} (\text{product of two sides into sine of} \\ \text{angle between them)} \dots \dots \dots \end{array} \right. \text{(III.)} \end{aligned}$$

EXAMPLE.—In triangle ABC , given $a = 22.3$ ins., $b = 35.6$ ins., $C = 49^\circ$, find the area.

$$\begin{aligned} \text{Area} &= \frac{1}{2} ab \sin C = \frac{1}{2} \times 22.3 \times 35.6 \sin 49^\circ \\ &= 11.15 \times 35.6 \times 0.7547 \\ \log 1115 &= 1.0472 \\ \log 35.6 &= 1.5514 \\ \log 0.7547 &= \bar{1}.8778 \\ \log (\frac{1}{2} ab \sin C) &= 2.4764 = \log 299.5 \\ \therefore \text{Area} &= 299.5 \text{ square inches} \end{aligned}$$

20. Given three sides of a triangle, to find its area.

We have area = $\frac{1}{2} ab \sin C$

The relation $\cos C = \frac{a^2 + b^2 - c^2}{2ab}$ gives $\cos C$ in terms of the sides.

From this we find $\sin C = \sqrt{1 - \cos^2 C}$, and substitute in the formula for the area.

EXAMPLE.—To find the area of a triangle whose sides a , b , and c are 4, 3, and 2 ins. in length respectively.

Practical Mathematics

$$\begin{aligned}\cos C &= \frac{a^2 + b^2 - c^2}{2ab} = \frac{16 + 9 - 4}{24} = \frac{7}{6} \\ \sin C &= \sqrt{1 - \cos^2 C} = \sqrt{1 - \frac{49}{36}} = 0.4841 \\ \therefore \text{area} &= \frac{1}{2}ab \sin C \\ &= \frac{1}{2} \cdot 4 \cdot 3 \cdot 0.4841 = 2.9046 \text{ sq. ins.}\end{aligned}$$

Verify by construction and measurement.

It may also be proved that the area of a triangle is equal to

$$\sqrt{s(s-a)(s-b)(s-c)}$$

where $s = \frac{a + b + c}{2}$

We shall here show that this formula is equivalent to the preceding.

$$\begin{aligned}\text{We have } s - a &= \frac{a + b + c}{2} - a = \frac{b + c - a}{2} \\ \text{similarly } s - b &= \frac{c + a - b}{2}, \quad s - c = \frac{a + b - c}{2} \\ \therefore \sqrt{s(s-a)(s-b)(s-c)} &= \frac{1}{4} \sqrt{(a+b+c)(a+b-c)(a-b+c)(-a+b+c)} \\ &= \frac{1}{4} \sqrt{2b^2c^2 + 2c^2a^2 + 2a^2b^2 - a^4 - b^4 - c^4} \quad \text{by} \\ &\quad \text{multiplying out} \\ &= \frac{1}{4} \sqrt{4a^2b^2 - (a^4 + b^4 + c^4 + 2a^2b^2 - 2b^2c^2 - 2c^2a^2)} \\ &= \frac{1}{2} ab \sqrt{1 - \left(\frac{a^2 + b^2 - c^2}{2ab} \right)^2} \\ &= \frac{1}{2} ab \sqrt{1 - \cos^2 C} = \frac{1}{2} ab \sin C \\ &= \text{area of triangle ABC, as already proved}\end{aligned}$$

EXAMPLE.—In the example, p. 33, we have

$$\begin{aligned}a &= 4, \quad b = 3, \quad c = 2 \\ s &= \frac{a + b + c}{2} = 4.5 \\ s - a &= 0.5; \quad s - b = 1.5; \quad s - c = 2.5 \\ \therefore \text{area} &= \sqrt{s(s-a)(s-b)(s-c)} \\ &= \sqrt{4.5 \times 0.5 \times 1.5 \times 2.5} \\ &= \frac{1}{4} \sqrt{9 \times 5 \times 3 \times 1} = \frac{3}{4} \sqrt{15} = 2.9046\end{aligned}$$

which agrees with the value found in the above example.

EXAMPLES.—XIV.

Find the area of the triangle **ABC**, when the following data are given —

1. $a = 3572$ ft., $b = 4621$ ft., $C = 59^\circ$.
2. $a = 2784$ ft., $b = 3685$ ft., $C = 82^\circ$.
3. $c = 31.6$ ft., $a = 21.25$ ft., $B = 16^\circ$.
4. $b = 331$ yds., $c = 567$ yds., $A = 76^\circ$.
5. $a = 562$ ft., $b = 343$ ft., $C = 65^\circ$.
6. $a = 51$ yds., $b = 62$ yds., $C = 72^\circ$.
7. $a = 5$ ft., $b = 7$ ft., $c = 9$ ft.

8. $a = 3.5$ ft., $b = 2.7$ ft., $c = 4.3$ ft.
 9. $a = 2.5$ ft., $b = 3.8$ ft., $c = 2.3$ ft.; find **B** and the area.
 10. $a = 4.32$ ft., $b = 6.71$ ft., $c = 9.32$ ft.; find **C** and the area.
 11. $a = 1$ ft., $b = 3$ ft., $c = 2.5$ ft.; find the three angles and the area.
 12. $a = 5$ ft., $b = 6$ ft., $c = 7$ ft.; find **A** and the area.
 13. Prove the relation

$$\frac{\sin A}{a} = \frac{\sin B}{b} = \frac{\sin C}{c}$$

by means of the formula III., for the area of a triangle.

30. Miscellaneous Problems on Solution of Triangles.

DEFINITION.—The *elevation* of an object which is higher than the eye of the observer, is the inclination to the horizontal of the straight line joining the eye of the observer to the object.

If we suppose a telescope to be first horizontal, and then to be turned in a vertical plane till the top of a hill can be seen through it, the angle through which it is turned is the elevation of the top of the hill.

The *depression* of an object which is lower than the eye of the observer is the inclination to the horizontal of the straight line joining the eye of the observer to the object.

If a telescope is placed in a horizontal position on the top of a hill and then turned downwards in a vertical plane till some object below can be seen through it, the angle through which the telescope is turned is the depression of that object.

EXAMPLE (1).—*A and B are two points in the same horizontal plane, and in the same straight line, with the foot of a tower, CD. From B the elevation of the top C of the tower is 23° ; from A it is 39° . $AB = 50$ ft. Find the height of the tower and its distance from A.*

Let the height, **CD**, of the tower be h , and let **AD** = x .

Then $\frac{AD}{DC} = \frac{x}{h} = \cot \text{DAC} = \cot 39^\circ = 1.2349$

$\frac{BD}{DC} = \frac{x + 50}{h} = \cot \text{DBC} = \cot 23^\circ = 2.3559$

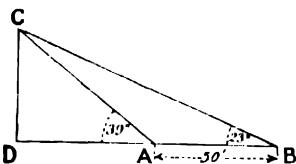

FIG. 26.

∴ subtracting, $\frac{50}{h} = 1.1210$

$$h = \frac{50}{1.1210} = 44.6 \text{ ft.}$$

$$x = h \times 1.2349 = 55.1 \text{ ft.}$$

∴ height of tower = 44.6 ft. Distance from **A** = 55.1 ft.

In problems on the solution of triangles, the student should, whenever possible, verify his results by construction to scale.

EXAMPLE (2).—*From the deck of a ship the elevation of the top of a mountain is 46° , and from the masthead it is 44° . The mast is 120 ft. high. Find the height of the mountain above the deck.*

In the figure, **AB** is the mast; **E** is the top of the mountain; **D** is a point at the level of the deck vertically under **E**.

Let $ED = h$, $AD = x$.

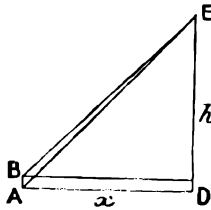

FIG. 27.

We have $\frac{h}{x} = \tan 46^\circ = 1.0355$

$$\frac{h - 120}{x} = \tan 44^\circ = 0.9657$$

\therefore subtracting, $\frac{120}{x} = 0.0698$

$$x = \frac{120}{0.0698}$$

$$\therefore h = x \tan 46^\circ = \frac{120 \times 1.0355}{0.0698} = 1780 \text{ ft.}$$

EXAMPLE (3).—The area of the cross-section of a rectangular prism is 92.30 sq. ins. What is the area of a section making an angle of 25° with the cross-section?

(Board of Education Examination, 1904.)

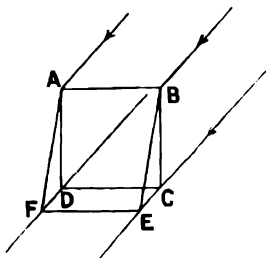

FIG. 27a.

Let $ABCD$ be the cross-section, $ABEF$ the section whose area is required.

$$\text{Then } \frac{\text{area } ABEF}{\text{area } ABCD} = \frac{AB \cdot BE}{AB \cdot BC} = \frac{BE}{BC} = \frac{1}{\cos EBC}$$

$$\therefore \text{area } ABEF = \frac{92.30}{\cos 25^\circ} = \frac{92.30}{0.9063} = 101.8 \text{ sq. ins.}$$

In a similar way it may be shown that, for a prism of any shape,

$$\frac{\text{area of cross-section}}{\text{area of any section } A} = \cos (\text{angle between } A \text{ and cross-section})$$

EXAMPLES.—XV.

1. A ladder, 35 ft. long, is resting against a wall. The foot of the ladder is found by measurement to be 6 ft. 3 ins. from the wall. What is the height of the top of the ladder above the ground?

2. A vertical cliff is 452 ft. high. From the top of the cliff the depression of a boat at sea is 18° . What is the distance of the boat from the foot of the cliff?

3. From a boat 1250 ft. from the base of a vertical cliff, the elevation of the top of a cliff is observed to be 15° . Find the height of the cliff.

4. The shadow of a tree is 37 ft. long when the elevation of the sun is 39° . What is the height of the tree?

5. From a point A the elevation of the top of a chimney is 27° . From B it is 14° . $BA = 120$ ft., and is horizontal, in the same straight line with the foot of the chimney. Find the height of the chimney.

6. From a point A on the bank of a river, a post further down the stream on the opposite side is seen in a direction making an angle of 58° with the bank. From a point B , 72 ft. up the stream, the post is seen in a direction making an angle of 35° with the bank. The banks are straight and parallel. Find the width of the river.

7. From the lower windows of a building, which are 15 ft. above the ground, the elevation of a balloon is 56° ; from an upper window, 92 ft. above the first, the elevation is 48° . What is the height of the balloon above the ground?

8. Observations to find the height of a mountain are taken at two points, A and B , 3521 ft. apart, at the same level, and in the same vertical plane with the top; the elevation of the top at A is 54° , and at B 37° . Find the height of the mountain.

9. From a milestone on a straight road going from E . to W ., a distant church tower is seen in a direction 10° W. of N . From the next milestone it is seen in a

direction 15° E. of N. Find the shortest distance from the church to the road, and the distance from the church to the first milestone.

10. There is a district in which the surface of the ground may be regarded as a sloping plane; its actual area is $3\cdot246$ sq. miles. It is shown on the map as an area of $2\cdot875$ sq. miles. At what angle is it inclined to the horizontal?

(Board of Education Examination, 1904.)

31. EXAMPLE (1).—From a telegraph post **A**, a house appears to be 35° W. of N. From the next telegraph post **B**, the house appears to be 20° W. of N. If the line **BA** is 88 yds. long in a direction 10° W. of N., find the distance of the house from **A**.

Let **C** be the position of the house. We require to find **AC**. In the triangle **ABC** we have the side **AB** equal to 88 yds. We shall find the angles **ACB** and **CBA**, and then solve the triangle by the formula (I), p. 26.

$$\begin{aligned} \text{We have } \angle ABC &= 20^\circ - 10^\circ = 10^\circ \\ \angle CAB &= 155^\circ \\ \angle BCA &= 180^\circ - \angle CAB - \angle ABC \\ &= 180^\circ - 155^\circ - 10^\circ = 15^\circ \\ \frac{CA}{AB} &= \frac{\sin \angle ABC}{\sin \angle BCA} = \frac{\sin 10^\circ}{\sin 15^\circ} \\ \therefore CA &= \frac{AB \sin 10^\circ}{\sin 15^\circ} = \frac{88 \times 0\cdot1736}{0\cdot2588} \end{aligned}$$

$$\begin{aligned} \log 88 &= 1\cdot9445 \\ \log 0\cdot1736 &= 1\cdot2395 \end{aligned}$$

$$\begin{array}{r} 1\cdot1840 \\ \log 0\cdot2588 = 1\cdot4130 \end{array}$$

$$\log AC = 1\cdot7710 = \log 59\cdot02$$

$$\therefore AC = 59\cdot02 \text{ yds.}$$

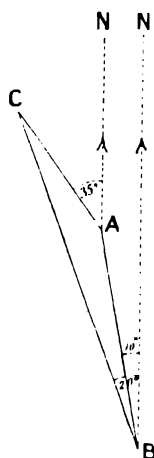

FIG. 28.

EXAMPLE (2).—At a point **C** the elevation of the top of a tower is 51° . At a point **D** on the side of a hill, in the same vertical plane as **C** and the tower, the elevation of the top is 72° . The slope of the hill from **C** through **D** to the foot of the tower is 20° to the horizontal, and the distance **CD** is 52 ft. Find the height of the tower.

Let **AB** be the tower of height h . Then the angle $\angle CAB = 90^\circ - 51^\circ = 39^\circ$ the angle $\angle DAB = 90^\circ - 72^\circ = 18^\circ$

$$\begin{aligned} \frac{CB}{h} &= \frac{\sin \angle CAB}{\sin \angle BCA} = \frac{\sin 39^\circ}{\sin 31^\circ}; \therefore CB = \frac{h \sin 39^\circ}{\sin 31^\circ} \\ \frac{DB}{h} &= \frac{\sin \angle DAB}{\sin \angle BDA} = \frac{\sin 18^\circ}{\sin 52^\circ}; \therefore DB = \frac{h \sin 18^\circ}{\sin 52^\circ} \end{aligned}$$

But we have $CB - DB = CD = 52$ ft.

$$\begin{aligned} \therefore \frac{h \sin 39^\circ}{\sin 31^\circ} - \frac{h \sin 18^\circ}{\sin 52^\circ} &= 52 \\ \therefore h &= \frac{52}{\frac{\sin 39^\circ}{\sin 31^\circ} - \frac{\sin 18^\circ}{\sin 52^\circ}} \\ &= \frac{52}{0\cdot6293 - 0\cdot3090} = \frac{52}{0\cdot3203} = 162\cdot48 \end{aligned}$$

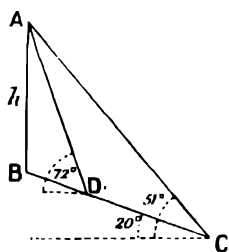

FIG. 29.

$$\log 0.6293 = \overline{1.7989}$$

$$\log 0.5150 = \overline{1.7118}$$

$$0.0871$$

$$= \log 1.2220$$

$$\underline{0.3922}$$

$$0.8298$$

$$\log 52 = 1.7160$$

$$\log 0.8298 = \overline{1.9190}$$

$$\log h = 1.7970 = \log 62.66$$

$$\therefore h = 62.66 \text{ ft.}$$

$$\log 0.3090 = \overline{1.4900}$$

$$\log 0.7880 = \overline{1.8965}$$

$$\underline{1.5935}$$

$$= \log 0.3922$$

EXAMPLE (3).—The top P of a hill is observed from two points A and B , 2150 ft. apart. The elevation of P at A is 30° . The angles PAB and PBA are 71° and 62° respectively. Find the height of the hill above the level of A .

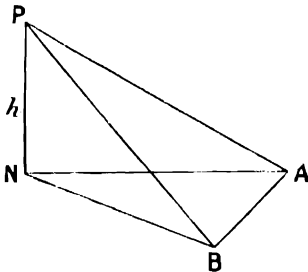

FIG. 30.

In the triangle APB we have given two angles and the base AB ; by the sine formula we can find the side AP ; from this and the angle PAN we find the height $PN = h$.

$$\text{The angle } APB = 180^\circ - 71^\circ - 62^\circ = 47^\circ.$$

In the triangle APB

$$\frac{AP}{AB} = \frac{\sin PBA}{\sin APB}$$

$$AP = \frac{AB \sin PBA}{\sin APB} = \frac{2150 \times \sin 62^\circ}{\sin 47^\circ}$$

Also in the triangle APN

$$\frac{h}{AP} = \sin PAN = \sin 30^\circ$$

$$\begin{aligned} \therefore h &= AP \sin 30^\circ = \frac{2150 \cdot \sin 62^\circ \cdot \sin 30^\circ}{\sin 47^\circ} \\ &= \frac{2150 \times 0.8829 \times 0.5}{0.7314} = \frac{2150 \times 0.4415}{0.7314} \end{aligned}$$

$$\log 2150 = 3.3324$$

$$\log 0.4415 = \overline{1.6449}$$

$$\underline{2.9773}$$

$$\log 0.7314 = \overline{1.8641}$$

$$\log h = 3.1132 = \log 1298$$

$$\therefore h = 1298 \text{ ft.}$$

EXAMPLES.—XVI.

1. From a milestone on a straight road going from S . to N ., the direction of a church tower appears to be 48° W . of N . From the next milestone the tower is seen in a direction 63° W . of S . Find the distance of the church tower from the first milestone, and the shortest distance between the church tower and the road.

If the elevation of the top of the tower from the first milestone is 2° , find its height.

2. A tower, PQ , stands on a hill which is inclined to the horizontal at an angle

of 16° . At two points, **A** and **B**, on the side of the hill, and in the same vertical plane as the top of the tower, the elevations of the top of the tower are 65° and 79° . $AB = 121$ ft. Find the height of the tower.

3. A tree stands on the top of a hill which has a uniform slope of 9° to the horizontal. At points **A** and **B** on the hill, in the same vertical plane as the tree, the elevations of the top of the tree are found to be 62° and 72° respectively. $AB = 13.2$ ft. Find the height of the tree.

4. Observations to find the height of a mountain are taken at two stations, **A** and **B**, 3521 ft. apart. The elevation of the top **P** at **A** is 54° . The angles **PAB** and **PBA** are 65° and 41° respectively. Find the height of the mountain.

5. Find the height in a similar case to that of the last example, when $AB = 7251$ ft., elevation of **P** at **A** is 43° , $PAB = 35^\circ$, $PBA = 49^\circ$.

6. Find the height when $AB = 4635$ ft., elevation of **P** at **A** is 38° , $PAB = 65^\circ$, $PBA = 82^\circ$.

7. Find the height when $AB = 5321$ ft., elevation of **P** at **A** is 45° , $PAB = 67^\circ$, $PBA = 73^\circ$.

8. Find the height when $AB = 1321$ ft., elevation of **P** at **A** is 46° , $PAB = 61^\circ$, $PBA = 75^\circ$.

9. In a survey it is required to continue a straight line, **AB**, past an obstacle; a line, **BD**, 100 yds. long is measured at right angles to **AB**. From **D** the lines **DP** and **DQ** are set off so that $BDP = 46^\circ$, $BDQ = 59^\circ$. Find the lengths of **DP** and **DQ**, so that **PQ** may be in the same straight line with **AB**.

10. Slieve Donard is seen from Skiddaw in a direction 16° S. of W., and from Snowdon in a direction 46° W. of N. If the distance in a straight line from Skiddaw to Snowdon is 118 miles in a direction 18° W. of S., find the distance from Skiddaw to Slieve Donard, and from Snowdon to Slieve Donard.

11. A base line **AB** is measured in a direction N. to S., and found to be 125 yds. long. A church tower appears in a direction 60° W. of S. from **A**, and 70° W. of N. from **B**. Find the distance of the church tower from **B**.

12. **A** is a pier-head, **L** is a lighthouse, **AL** is known to be 2.5 miles in a direction due N. A ship sails from **A** to **C** in a north-easterly direction. At **C** the lighthouse appears in a direction 80° W. of N. How far has the ship sailed from **A** to **C**?

CHAPTER IV

THE ADDITION FORMULÆ

32. Sine of the Sum of Two Angles.—It is a common mistake of beginners to think that the sine of the sum of two angles is equal to the sum of their sines. It is, of course, obvious from the geometrical definition of a sine that this is not so. Also, taking a numerical example, we find from the tables that

$$\begin{aligned} \sin 10^\circ &= 0.1736, \quad \sin 30^\circ = 0.5000 \\ \therefore \sin 10^\circ + \sin 30^\circ &= 0.6736, \quad \text{while } \sin 40^\circ = 0.6428 \end{aligned}$$

We require then to find an expression for $\sin(A + B)$ when the trigonometrical ratios of A and B are given.

33. To prove that $\sin(A + B) = \sin A \cos B + \cos A \sin B$.

Let A and B be any acute angles.

Construct the angles ROP and ROQ equal to A and B respectively on opposite sides of the straight line OR .

Draw PRQ perpendicular to OR .

Let $OP = p$, $OR = r$, $OQ = q$.

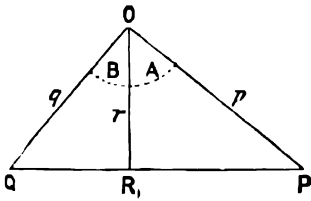

FIG. 31.

$$\begin{aligned} \text{Then } \triangle OPQ &= \triangle OPR + \triangle ORQ \\ \frac{1}{2} pq \sin(A + B) &= \frac{1}{2} pr \sin A + \frac{1}{2} rq \sin B \\ \sin(A + B) &= \frac{r}{q} \sin A + \frac{r}{p} \sin B \\ &= \sin A \cos B + \cos A \sin B \quad (1) \end{aligned}$$

34. To prove that $\sin(A - B) = \sin A \cos B - \cos A \sin B$.

Let A and B be acute angles, A being greater than B . Construct the angles ROP and ROQ equal to A and B respectively on the same side of the straight line OR .

Draw PQR perpendicular to OR .

Let $OP = p$, $OQ = q$, $OR = r$.

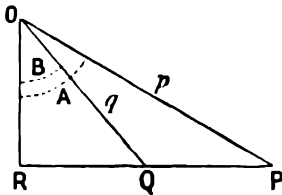

FIG. 32.

$$\begin{aligned} \text{Then } \triangle OPQ &= \triangle OPR - \triangle OQR \\ \frac{1}{2} pq \sin(A - B) &= \frac{1}{2} pr \sin A - \frac{1}{2} qr \sin B \\ \sin(A - B) &= \frac{r}{q} \sin A - \frac{r}{p} \sin B \\ &= \sin A \cos B - \cos A \sin B \quad (2) \end{aligned}$$

35. $\cos(A + B) = \cos A \cos B - \sin A \sin B$ (3)

$\cos(A - B) = \cos A \cos B + \sin A \sin B$ (4)

Let **A** and **B** be acute angles. Then the complement of **A** will also be acute, and in the formulæ for $\sin(\mathbf{A} + \mathbf{B})$ we may write the complement $(90^\circ - \mathbf{A})$ instead of **A**. We get

$$\begin{aligned} \sin(90^\circ - \mathbf{A} + \mathbf{B}) &= \sin(90^\circ - \mathbf{A}) \cos \mathbf{B} + \cos(90^\circ - \mathbf{A}) \sin \mathbf{B} \\ \therefore \sin(90^\circ - (\mathbf{A} - \mathbf{B})) &= \cos \mathbf{A} \cos \mathbf{B} + \sin \mathbf{A} \sin \mathbf{B} \\ \text{that is, } \cos(\mathbf{A} - \mathbf{B}) &= \cos \mathbf{A} \cos \mathbf{B} + \sin \mathbf{A} \sin \mathbf{B} \end{aligned}$$

since any trigonometrical ratio of an angle is equal to the co-ratio of its complement. Similarly

$$\begin{aligned} \sin(90^\circ - \mathbf{A} - \mathbf{B}) &= \sin(90^\circ - \mathbf{A}) \cos \mathbf{B} - \cos(90^\circ - \mathbf{A}) \sin \mathbf{B} \\ \text{that is, } \cos(\mathbf{A} + \mathbf{B}) &= \cos \mathbf{A} \cos \mathbf{B} - \sin \mathbf{A} \sin \mathbf{B} \end{aligned}$$

Note that these formulæ have not yet been proved for any values of the angles **A** and **B**, but only for the case when the angles **A** and **B** are acute. A general proof for any values of **A** and **B** will be given in Chapter XXI., on Vector Algebra.

EXAMPLE.—To verify the formula for $\sin(\mathbf{A} - \mathbf{B})$ for the case when $\mathbf{A} = 83^\circ$, $\mathbf{B} = 39^\circ$, by computation from the tables.

$$\sin(\mathbf{A} - \mathbf{B}) = \sin \mathbf{A} \cos \mathbf{B} - \cos \mathbf{A} \sin \mathbf{B}$$

When $\mathbf{A} = 83^\circ$, $\mathbf{B} = 39^\circ$, this becomes

$$\begin{aligned} \sin 44^\circ &= \sin 83^\circ \cos 39^\circ - \cos 83^\circ \sin 39^\circ \\ &= 0.9925 \times 0.7771 - 0.1219 \times 0.6293 \\ &= 0.7713 - 0.0767 = 0.6946 \\ \log 0.9925 &= \bar{1}.9967 & \log 0.1219 &= \bar{1}.0860 \\ \log 0.7771 &= \bar{1}.8905 & \log 0.6293 &= \bar{1}.7989 \\ \log 0.7713 &= \bar{1}.8872 & \log 0.0767 &= \bar{2}.8849 \end{aligned}$$

From the tables we find $\sin 44^\circ = 0.6947$.

$$36. \tan(\mathbf{A} + \mathbf{B}) = \frac{\tan \mathbf{A} + \tan \mathbf{B}}{1 - \tan \mathbf{A} \tan \mathbf{B}}$$

We have

$$\begin{aligned} \tan(\mathbf{A} + \mathbf{B}) &= \frac{\sin(\mathbf{A} + \mathbf{B})}{\cos(\mathbf{A} + \mathbf{B})} \\ &= \frac{\sin \mathbf{A} \cos \mathbf{B} + \cos \mathbf{A} \sin \mathbf{B}}{\cos \mathbf{A} \cos \mathbf{B} - \sin \mathbf{A} \sin \mathbf{B}} \end{aligned}$$

Dividing the numerator and denominator of this fraction by $\cos \mathbf{A} \cos \mathbf{B}$, we get

$$\begin{aligned} \tan(\mathbf{A} + \mathbf{B}) &= \frac{\frac{\sin \mathbf{A}}{\cos \mathbf{A}} + \frac{\sin \mathbf{B}}{\cos \mathbf{B}}}{1 - \frac{\sin \mathbf{A}}{\cos \mathbf{A}} \cdot \frac{\sin \mathbf{B}}{\cos \mathbf{B}}} \\ &= \frac{\tan \mathbf{A} + \tan \mathbf{B}}{1 - \tan \mathbf{A} \tan \mathbf{B}} \quad \dots \dots \dots (5) \end{aligned}$$

$$\begin{aligned}
 \text{Similarly } \tan(A - B) &= \frac{\sin(A - B)}{\cos(A - B)} \\
 &= \frac{\sin A \cos B - \cos A \sin B}{\cos A \cos B + \sin A \sin B} \\
 &= \frac{\sin A - \sin B}{\cos A + \cos B} \\
 &= \frac{1 + \frac{\sin A}{\cos A} \cdot \frac{\sin B}{\cos B}}{1 + \frac{\sin A}{\cos A} \cdot \frac{\sin B}{\cos B}} \\
 &= \frac{\tan A - \tan B}{1 + \tan A \tan B} \quad \dots \dots \dots (6)
 \end{aligned}$$

37. The following examples are important in the study of oscillations in mechanics:—

EXAMPLE (1).—Let $x = a \sin pt + b \cos pt$ for any value of t where a , b , and p are constant numbers; show that this is the same as $x = A \sin(pt + g)$ if the values of A and g are properly chosen.

(Board of Education Examination, 1901.)

We have $A \sin(pt + g) = A \cos g \sin pt + A \sin g \cos pt$.

To make this the same as $a \sin pt + b \cos pt$ for any value of t , we must choose A and g , so that

$$A \cos g = a; \quad A \sin g = b$$

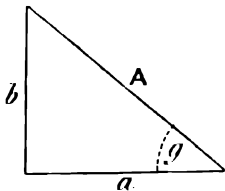

FIG. 33.

Construct a right-angled triangle whose base is a and height b .

Let its hypotenuse be equal to A , and the angle at the base be equal to g . Then, evidently

$$a = A \cos g, \quad b = A \sin g$$

Therefore A and g have been chosen to satisfy the condition (1), and, with these values of A and g , $a \sin pt + b \cos pt$ is the same as $A \sin(pt + g)$ for any value of t .

To calculate A and g we have

$$A = \sqrt{a^2 + b^2}; \quad \tan g = \frac{b}{a}$$

EXAMPLE (2).—To express $x = 3 \sin 4t + 7 \cos 4t$ in the form $A \sin(4t + g)$.

$$\text{We have } A = \sqrt{9 + 49} = 7.616$$

$$\tan g = \frac{7}{3} = \tan 66.8^\circ$$

$$\therefore g = 66.8^\circ = 1.166 \text{ radians}$$

$$\therefore x = 7.616 \sin(4t + 1.166)$$

Similarly, if

$$x = 3 \sin 4t - 7 \cos 4t$$

$$\text{we have } A = 7.616; \quad \tan g = -\frac{7}{3} = -\tan 66.8^\circ$$

\therefore if we take the numerically smallest angle which has its tangent equal to $-\frac{7}{3}$, $g = -1.166$

$$\text{and } x = 7.616 \sin(4t - 1.166)$$

The reason for expressing the angle $(pt + g)$ in radians will appear at a later stage.

EXAMPLES.—XVII.

The student should work through the following examples in verification, in order to fix the formulæ of this chapter in his memory, and also to gain a knowledge of the degree of accuracy attainable in working with four-figure tables.

1. Verify from the tables the formulæ for $\sin(A + B)$ and $\sin(A - B)$, when $A = 60^\circ$, $B = 30^\circ$.
2. Verify the formula for $\cos(A + B)$ for the case when $A = 15^\circ$, $B = 31^\circ$.
3. Verify the formula for $\sin(A - B)$ for the case when $A = 37^\circ$, $B = 34^\circ$.
4. Verify the formula for $\cos(A - B)$ for the case $A = 42^\circ$, $B = 43^\circ$.
5. Verify the formula for $\tan(A + B)$ when $A = 12^\circ$, $B = 15^\circ$.
6. Given $\tan(A + B) = 2$, $\tan A = 0.5$; find $\tan B$.
7. Given $\sin A = \frac{3}{5}$, $\sin B = \frac{3}{8}$; find $\sin(A + B)$.
8. Given $\sin A = \frac{6}{11}$, $\cos B = \frac{4}{11}$; find $\sin(A + B)$ and $\cos(A + B)$. Also construct the angles A , B , and $A + B$; measure their sines and cosines, and verify from the measured values.
9. Given $\tan A = \frac{3}{4}$, $\tan B = \frac{9}{11}$; find $\tan(A + B)$.
10. Given $\sin A = \frac{4}{5}$, $\cos B = \frac{3}{5}$; find $\cos(A - B)$.
11. Given $\cos A = \frac{4}{5}$, $\sin B = \frac{11}{13}$; find $\sin(A + B)$ and $\tan(A + B)$.
12. Given $\sin A = \frac{2}{3}$, $\tan B = \frac{5}{12}$; find $\cos(A + B)$.
13. Express $2 \sin 2t + 3 \cos 2t$ in the form $A \sin(2t + g)$, expressing the angle g in radians.
14. Express $3 \sin 2t - 2 \cos 2t$ in the form $A \sin(2t + g)$.
15. Express $45 \sin(2\pi nt) + 28 \cos(2\pi nt)$ in the form $A \sin(2\pi nt + g)$.
16. Express $35 \sin \frac{2\pi t}{p} - 12 \cos \frac{2\pi t}{p}$ in the form $A \sin\left(\frac{2\pi t}{p} + g\right)$.
17. Given $\tan(A - B) = 0.0893$, and $\tan A = 0.4$; find the angle B to the nearest degree.
18. If $\tan \theta = \frac{m_1 - m_2}{1 + m_1 m_2}$, find m_2 , having given that $m_1 = \frac{1}{2}$, $\tan \theta = \frac{2}{3}$.

38. To prove

$$\begin{aligned} \sin 2A &= 2 \sin A \cos A \\ \cos 2A &= \cos^2 A - \sin^2 A \\ \tan 2A &= \frac{2 \tan A}{1 - \tan^2 A} \end{aligned}$$

If in the equation

$$\sin(A + B) = \sin A \cos B + \cos A \sin B$$

we put $B = A$, we get

$$\sin(A + A) = \sin A \cos A + \cos A \sin A$$

or

$$\sin 2A = 2 \sin A \cos A \dots \dots \dots (7)$$

If in the equation

$$\cos(A + B) = \cos A \cos B - \sin A \sin B$$

we put $B = A$, we get

$$\cos(A + A) = \cos A \cos A - \sin A \sin A$$

or

$$\cos 2A = \cos^2 A - \sin^2 A \dots \dots \dots (8)$$

This gives $\cos 2A$ in terms of $\cos A$ and $\sin A$.

To find $\cos 2A$ in terms of $\cos A$ only, we have

$$\begin{aligned} \sin^2 A &= 1 - \cos^2 A \\ \therefore \cos 2A &= \cos^2 A - (1 - \cos^2 A) = 2 \cos^2 A - 1 \quad \dots (9) \end{aligned}$$

To find $\cos 2A$ in terms of $\sin A$, we have

$$\begin{aligned} \cos^2 A &= 1 - \sin^2 A \\ \cos 2A &= (1 - \sin^2 A) - \sin^2 A = 1 - 2 \sin^2 A \quad \dots (10) \end{aligned}$$

If in the relation

$$\tan(A + B) = \frac{\tan A + \tan B}{1 - \tan A \tan B}$$

we put $B = A$, we get

$$\tan 2A = \frac{2 \tan A}{1 - \tan^2 A} \quad \dots (11)$$

If in the relation

$$\cos 2A = 2 \cos^2 A - 1 = 1 - 2 \sin^2 A$$

we write $\frac{A}{2}$ for A , we get

$$\cos A = 2 \cos^2 \frac{A}{2} - 1 = 1 - 2 \sin^2 \frac{A}{2} \quad \dots (12)$$

These equations enable us to find the cosine or sine of the half of an angle when the cosine of that angle is given.

EXAMPLE (1).—*To find the sine and cosine of 80° , having given the sine and cosine of 40° .*

$$\begin{aligned} \sin 40^\circ &= 0.6428; \quad \cos 40^\circ = 0.7660 \\ \therefore \sin 80^\circ &= 2 \sin 40^\circ \cos 40^\circ = 2 \times 0.6428 \times 0.7660 = 0.9847 \end{aligned}$$

From the tables $\sin 80^\circ = 0.9848$.

$$\cos 80^\circ = 2 \cos^2 40^\circ - 1 = 2(0.7660)^2 - 1 = 1.1735 - 1 = 0.1735$$

By the tables $\cos 80^\circ = 0.1736$.

EXAMPLE (2).—*Given $\tan 45^\circ = 1$, find $\tan 90^\circ$.*

$$\tan 90^\circ = \tan(2 \times 45^\circ) = \frac{2 \tan 45^\circ}{1 - \tan^2 45^\circ} = \frac{2}{0} = \infty$$

which agrees with § 17.

EXAMPLES.—XVIII.

1. Calculate the values of the sine and cosine of 60° by the formulæ of this paragraph, having given $\sin 30^\circ = 0.500$, $\cos 30^\circ = 0.866$.

2. Calculate the values of the sine and cosine of 56° , having given $\sin 28^\circ = 0.4695$, $\cos 28^\circ = 0.8829$, and compare your results with the tables.

3. Given $\cos A = 0.4$, calculate $\cos 2A$.

4. Given $\cos A = 0.3$, calculate $\sin 2A$.

5. Given $\sin A = \frac{3}{4}$, find $\sin 2A$, $\cos 2A$, $\tan 2A$. Verify your result by constructing the angles A and $2A$, and finding the sine and cosine of $2A$ by measurement.

6. Given $\tan A = \frac{1}{3}$, calculate $\tan 2A$, and verify by construction and measurement.

7. Given $\tan A = 0.25$, calculate $\tan 2A$.

8. Given $\sin 45^\circ = \frac{1}{\sqrt{2}}$, calculate $\cos 90^\circ$.

9. Given $\sin A = 0.85$, calculate $\cos 2A$ and $\sin 2A$, and verify by construction.

10. Given $\sin A = \frac{3}{5}$, calculate $\sin 2A$, $\cos 2A$, and $\tan 2A$.

11. Given $\cos A = 0.7$, find $\sin 2A$ and $\cos 2A$.

12. Express $a \cos(2\pi nt) + b \cos(4\pi nt)$ in terms of $\cos(2\pi nt)$.

13. Given $\cos 66^\circ = 0.4067$, calculate $\cos 33^\circ$ and $\sin 33^\circ$ by formula (12), and compare with the tables.

14. If A is an acute angle, and $\cos A = 0.28$, calculate $\cos \frac{A}{2}$.

15. If A is an acute angle, and $\cos A = 0.68$, calculate $\sin \frac{A}{2}$.

16. If $\sin A = \frac{2}{3}$, and A is acute, calculate $\sin \frac{A}{2}$ and $\cos \frac{A}{2}$, and verify by construction and measurement.

39. To express the Sum or Difference of two Sines or Cosines as a Product.—The following results have been proved:—

$$\begin{aligned} \sin(A + B) &= \sin A \cos B + \cos A \sin B \\ \sin(A - B) &= \sin A \cos B - \cos A \sin B \\ \cos(A + B) &= \cos A \cos B - \sin A \sin B \\ \cos(A - B) &= \cos A \cos B + \sin A \sin B \end{aligned}$$

By addition and subtraction we get

$$\begin{aligned} \sin(A + B) + \sin(A - B) &= 2 \sin A \cos B \\ \sin(A + B) - \sin(A - B) &= 2 \cos A \sin B \\ \cos(A + B) + \cos(A - B) &= 2 \cos A \cos B \\ \cos(A + B) - \cos(A - B) &= -2 \sin A \sin B \end{aligned}$$

$$\text{Let } A + B = P, \quad A - B = Q$$

$$\text{Then } 2A = P + Q, \quad A = \frac{P + Q}{2}$$

$$2B = P - Q, \quad B = \frac{P - Q}{2}$$

And the above formulæ become

$$\begin{aligned} \sin P + \sin Q &= 2 \sin \frac{P + Q}{2} \cdot \cos \frac{P - Q}{2} \\ \sin P - \sin Q &= 2 \cos \frac{P + Q}{2} \cdot \sin \frac{P - Q}{2} \\ \cos P + \cos Q &= 2 \cos \frac{P + Q}{2} \cdot \cos \frac{P - Q}{2} \\ \cos P - \cos Q &= -2 \sin \frac{P + Q}{2} \cdot \sin \frac{P - Q}{2} \end{aligned}$$

These formulæ are important, and should be remembered.

They may be expressed in words as follows:—

Sum of two sines = twice \sin (half-sum) \cdot \cos (half-difference). (13)

Difference of two sines = twice \cos (half-sum) \cdot \sin (half-difference). (14)

Sum of two cosines = twice \cos (half-sum) \cdot \cos (half-difference). (15)

Difference of two cosines = $-$ twice \sin (half-sum) \cdot \sin (half-difference). (16)

NOTE.—In finding the difference in the above formulæ it is understood that the two angles are taken in the same order on both sides of the equation; e.g. if we put $\cos P$ before $\cos Q$ in finding the difference of two cosines in formula (16), we must also put P before Q in finding the sine of half the difference.

EXAMPLE.—To express $\sin 15^\circ - \sin 11^\circ$ as a product.

$$\begin{aligned}\sin 15^\circ - \sin 11^\circ &= 2 \cos \frac{15^\circ + 11^\circ}{2} \sin \frac{15^\circ - 11^\circ}{2} \\ &= 2 \cos 13^\circ \sin 2^\circ\end{aligned}$$

To verify this we have, substituting the values from the tables,

$$\begin{aligned}\sin 15^\circ - \sin 11^\circ &= 0.2588 - 0.1908 = 0.0680 \\ 2 \cos 13^\circ \sin 2^\circ &= 2 \times 0.9744 \times 0.0349 = 0.0680\end{aligned}$$

EXAMPLE.—To express $\cos 11^\circ - \cos 17^\circ$ as a product.

$$\begin{aligned}\cos 11^\circ - \cos 17^\circ &= -2 \sin \frac{11^\circ + 17^\circ}{2} \sin \frac{11^\circ - 17^\circ}{2} \\ &= -2 \sin 14^\circ \sin (-3^\circ) \\ &= 2 \sin 14^\circ \sin 3^\circ\end{aligned}$$

To verify we have, from the tables,

$$\begin{aligned}\cos 11^\circ - \cos 17^\circ &= 0.9816 - 0.9563 = 0.0253 \\ 2 \sin 14^\circ \sin 3^\circ &= 2 \times 0.2419 \times 0.0523 = 0.0253\end{aligned}$$

EXAMPLES.—XIX.

Express the following as products, and verify by the tables:—

1. $\sin 65^\circ + \sin 58^\circ$.
2. $\sin 74^\circ - \sin 46^\circ$.
3. $\sin 45^\circ - \sin 77^\circ$.
4. $\cos 16^\circ - \cos 54^\circ$.
5. $\cos 47^\circ - \cos 19^\circ$.
6. $\cos 39^\circ + \cos 27^\circ$.
7. $\cos 155^\circ + \cos 20^\circ$.
8. $\cos 200^\circ - \cos 135^\circ$.
9. $\sin 210^\circ - \sin 135^\circ$.
10. $\sin 300^\circ + \sin 200^\circ$.
11. $\cos 400^\circ - \cos 200^\circ$.
12. Prove that $\cos 105^\circ + \cos 15^\circ = \cos 45^\circ$.
13. Prove that $\sin 45^\circ + \sin 15^\circ = \cos 15^\circ$.
14. Prove that $\sin 3A + \sin 5A = 2 \sin 4A \cos A$.
15. Prove that $\cos 3A = \cos A - 2 \sin A \sin 2A$, and verify from the tables for the case when $A = 20^\circ$.

40. To express the Product of Two Sines or Cosines as a Sum or Difference.—Reversing the equations obtained in the last paragraph, we get

$$\begin{aligned}2 \sin A \cos B &= \sin (A + B) + \sin (A - B) \\ 2 \cos A \sin B &= \sin (A + B) - \sin (A - B) \\ 2 \cos A \cos B &= \cos (A + B) + \cos (A - B) \\ 2 \sin A \sin B &= \cos (A - B) - \cos (A + B)\end{aligned}$$

These relations may be expressed in words as follows:—

Twice the product of a sine and cosine = \sin (sum) + \sin (difference) (17)

Twice the product of two cosines = \cos (sum) + \cos (difference) (18)

Twice the product of two sines = \cos (difference) - \cos (sum) (19)

Note that the first of these statements includes the two equations above, giving $2 \sin A \cos B$, and $2 \cos A \sin B$, if it is understood that in finding the difference $A - B$ or $B - A$, we take the angles in the same order as that

in which they occur on the left-hand side of the equation, $-\sin(A - B)$ in the second equation above is then equal to $\sin(B - A)$; *i.e.* it is equal to the sine of the difference between the two angles.

EXAMPLE.—*To express $\sin 31^\circ \cos 45^\circ$ as a sum or difference.*

$$\begin{aligned} \text{By (17) } \sin 31^\circ \cos 45^\circ &= \frac{1}{2} \{ \sin (31^\circ + 45^\circ) + \sin (31^\circ - 45^\circ) \} \\ &= \frac{1}{2} (\sin 76^\circ - \sin 14^\circ) \end{aligned}$$

To verify this we find, from the tables,

$$\begin{aligned} \sin 31^\circ \cos 45^\circ &= 0\cdot5150 \times 0\cdot7071 = 0\cdot3642 \\ \frac{1}{2} \{ \sin 76^\circ - \sin 14^\circ \} &= \frac{1}{2} (0\cdot9703 - 0\cdot2419) = 0\cdot3642 \end{aligned}$$

EXAMPLES.—XX.

Express each of the following as a sum or difference, and verify by the tables.

- | | | |
|---------------------------------------|-------------------------------------|--------------------------------------|
| 1. $\sin 45^\circ \cos 31^\circ$. | 2. $\sin 50^\circ \sin 30^\circ$. | 3. $\sin 25^\circ \sin 45^\circ$. |
| 4. $\cos 25^\circ \cos 54^\circ$. | 5. $\cos 62^\circ \cos 35^\circ$. | 6. $\sin 15^\circ \cos 54^\circ$. |
| 7. $\sin 123^\circ \cos 54^\circ$. | 8. $\cos 142^\circ \sin 80^\circ$. | 9. $\sin 115^\circ \sin 170^\circ$. |
| 10. $\cos 200^\circ \cos 300^\circ$. | | |

11. Express as a sum or difference $a \sin pt \cdot b \sin \left(pt + \frac{\pi}{2} \right)$.

12. Express $\sin 2\pi nt \sin (2\pi nt + g)$ as a sum or difference, and verify numerically for the case $n = 10$, $t = 0\cdot01$, $g = 0\cdot3491$ radian.

CHAPTER V

USE OF FORMULÆ

41. It is one of the objects of an exact science to express the connection between different physical quantities by means of formulæ, and a great part of the practical work of applied science consists in the evaluation of such formulæ. In carrying out any particular calculation we have to notice (1) the degree of accuracy with which the data are given; (2) the degree of accuracy in the result needed for the purpose in hand. It is evidently meaningless to carry out a calculation to more significant figures than the accuracy of the data will warrant, while it is a waste of time to carry it out to more figures than are needed. It is a common fault of beginners, while possibly making large errors in the magnitude of a result, to be unduly solicitous about carrying out the calculation to a large number of significant figures.

In engineering calculations an accuracy to three or four significant figures, such as can be obtained with a good 10-inch slide rule, will usually be found sufficient.

As accurate numerical working is extremely important in applied science, a number of examples in the evaluation of more complicated formulæ is given in this chapter.

The degree of accuracy aimed at is that which can be secured by using a table of four-figure logarithms.

EXAMPLE (1).—Calculate the value of

$$W = \frac{p_1 v_1^n}{1-n} \{v_2^{1-n} - v_1^{1-n}\}$$

Having given that $v_2 = 10$, $v_1 = 3$, $n = 0.9$, $p_2 = 3000$, and $p_1 v_1^n = p_2 v_2^n$

$$\text{we have } W = \frac{3000 \times 10^{0.9}}{0.1} \{10^{0.1} - 3^{0.1}\}$$

$$\log 10 = 1$$

$$\therefore \log 10^{0.9} = 0.9 = \log 7.943$$

$$\log 10^{0.1} = 0.1 = \log 1.259$$

$$\log 3 = 0.4771$$

$$\therefore \log 3^{0.1} = 0.04771 = \log 1.116$$

$$\therefore W = 30000 \times 7.943 (1.259 - 1.116)$$

$$= 238290 \times 0.143 = 34080$$

EXAMPLE (2).—Calculate the value of $ae^{-kt} \sin (nt + g)$

when $a = 5$, $k = 44$, $t = 0.005$, $n = 1000$, $g = 1.2217$

The angle is measured in radians.

$$ae^{-kt} = 5 \times (2.718)^{-0.22}$$

$$\log 2.718 = 0.4343$$

$$- 0.22$$

$$\log (2.718)^{-0.22} = -0.09555 = \bar{1}.90445 = \log 0.8025$$

$$\begin{aligned} \therefore ae^{-kt} &= 5 \times 0.8025 = 4.0125 \\ nt + g &= (5 + 1.2217) \text{ radians} \\ &= (5 \times 57.3 + 70) \text{ degrees by tables} \\ &= 356.5^\circ \\ \sin(nt + g) &= \sin(356.5^\circ) = -\sin 3.5^\circ \\ &= -0.06105 \\ \log 4.0125 &= 0.6033 \\ \log 0.06105 &= 2.7857 \end{aligned}$$

$$\begin{aligned} \log(4.0125 \times 0.06105) &= \overline{1.3890} = \log 0.2449 \\ \therefore ae^{-kt} \sin(nt + g) &= -0.245 \end{aligned}$$

EXAMPLE (3).—

$$\text{If } \phi = 1.0565 \log_e \frac{t}{273.7} + 9 \times 10^{-7} \left(\frac{t^2}{2} - 502.96t \right) + 0.0902$$

find the value of ϕ when $t = 393.7$ to as high a degree of accuracy as can be obtained with four-figure tables.

Calculations of this type occur in many problems on the steam-engine.

$$t = 393.7$$

$$1.0565 \log_e \frac{t}{273.7} :-$$

$$\log_e \frac{393.7}{273.7} = 2.3026 \log_{10} \frac{393.7}{273.7}$$

$$\log_{10} 393.7 = 2.5952$$

$$\log_{10} 273.7 = 2.4373$$

$$\log_{10} \frac{393.7}{273.7} = 0.1579$$

$$1.0565 \log_e \frac{t}{273.7} = 1.0565 \times 2.3026 \times 0.1579$$

$$\log 1.0565 = 0.0238$$

$$\log 2.3026 = 0.3622$$

$$\log 0.1579 = \overline{1.1984}$$

$$\log_{10} \left(1.0565 \log_e \frac{t}{273.7} \right) = \overline{1.5844} = \log_{10} 0.3841$$

$$\therefore 1.0565 \log_e \frac{t}{273.7} = 0.3841 \dots \dots \dots (a)$$

$$9 \times 10^{-7} \left(\frac{t^2}{2} - 502.96t \right) = 9 \times 10^{-7} \left(\frac{t^2}{2} - 502.96 \right)$$

$$\begin{aligned} &= 9 \times 10^{-7} \times 393.7(196.85 - 502.96) \\ &= -3543.3 \times 306.11 \times 10^{-7} \end{aligned}$$

$$\log 3543.3 = 3.5494$$

$$\log 306.11 = 2.4858$$

$$\log(3543.3 \times 306.11) = 6.0352 = \log 1085000$$

$$\therefore 9 \times 10^{-7} \left(\frac{t^2}{2} - 502.96t \right) = -0.1085 \dots \dots \dots (b)$$

\therefore combining (a) and (b)

$$\phi = 0.3841 - 0.1085 + 0.0902 = 0.3658$$

$$\therefore \phi = 0.366 \text{ to 3 significant figures}$$

The student who has not had much practice with logarithms will find that he is particularly prone to make arithmetical mistakes in working from complicated formulæ of this kind where logarithms occur in the formula itself. The only way to ensure accuracy is to set out every step of the working clearly, so as to show every figure used in the calculation and the reason for its appearance. This process may seem long, but it will be found to save time in the long run.

42. Variation.—If we examine the graduations on a spring balance we find that they are situated at equal distances apart. If we alter the weight so that it is multiplied by any number n , then the extension of the spring, as measured from its length when no weight is attached, is multiplied by the same number n . We describe this connection between the two variable quantities by saying that the extension varies as the weight. We may express this fact by means of a formula. Suppose we find that the divisions representing successive pounds are $\frac{1}{8}$ inch apart, then, if e be the number expressing the extension of the spring in inches when supporting a weight W lbs., it is evident that e is always numerically equal to $\frac{1}{8}W$; i.e. the equation $e = \frac{1}{8}W$ expresses the fact that e varies as W .

In general, if A varies as B , we may write $A = kB$ where k is a constant quantity, which does not change as A and B vary; in the above example the constant k is $\frac{1}{8}$. Simple variation such as this is the simplest way in which two variable quantities can be connected together, but there are, of course, many other possible modes of connection.

If we enclose a portion of a gas in a tube and change the pressure to which it is subjected, while keeping its temperature constant, we find that, if the pressure be changed so that its value is multiplied by any number n , then the volume is changed so that its value is divided by the same number n . We describe this connection by saying that the volume varies inversely as the pressure.

It may be expressed in a formula by writing $V = \frac{k}{P}$, for, if we put nP for P in this equation, V becomes $\frac{k}{nP} = \frac{V}{n}$.

Similarly, if a variable quantity A depends on two variable quantities B and C , in such a way that $A = kBC$, we say that A varies jointly as B and C , or, if $A = \frac{kB}{C}$, we say that A varies directly as B and inversely as C .

The sign \propto is used to denote the words "varies as," thus " $A \propto B$ " means " A varies as B ."

EXAMPLE (1).—*The volume of a gas varies inversely as the pressure and directly as the absolute temperature. If a certain quantity of a gas measures 500 c.c. at temperature 13° C., and pressure 754 mm., what is its volume at pressure 784 mm. and temperature 29° C.*

The absolute temperature T is obtained by adding 273·7 to the temperature Centigrade.

$$\text{We assume } v = \frac{RT}{p} \text{ where } R \text{ is some constant}$$

$$\text{When } T = 286\cdot7, \text{ and } p = 754, \text{ we have } v = 500$$

$$\therefore \text{ substituting } 500 = \frac{R \times 286\cdot7}{754}$$

$$R = \frac{500 \times 754}{286\cdot7}$$

∴ when $T = 302.7$, and $f = 784$

$$v = \frac{R \times 302.7}{784} = \frac{500 \times 754 \times 302.7}{286.7 \times 784} \\ = 508 \text{ cc.}$$

EXAMPLE (2).—In any class of turbine P is the power of the waterfall, H the height of the fall, and n the rate of revolution. It is known that for any particular class of turbines of all sizes $n \propto H^{1.25} P^{-0.5}$.

In the list of a particular maker I take a turbine at random for a fall of 6 ft., 100 H.P., 50 revolutions per minute. By means of this I find that I can calculate n for all the other turbines on the list.

Find n for a fall of 20 ft. and 75 H.P.

(Board of Education Examination, 1901.)

We have $n = kH^{1.25} P^{-0.5}$

When $H = 6$ and $P = 100$, $n = 50$

$$\therefore 50 = k \cdot 6^{1.25} 100^{-0.5} = \frac{k}{10} \cdot 6^{1.25}$$

$$\text{and } k = \frac{500}{6^{1.25}}$$

when $H = 20$ and $P = 75$ we have

$$n = k \frac{H^{1.25}}{\sqrt{P}} = \frac{500 \times 20^{1.25}}{6^{1.25} \times \sqrt{75}}$$

$$= \frac{500}{5\sqrt{3}} \cdot (2.0)^{1.25}$$

$$= \frac{100}{\sqrt{3}} \cdot (3.333)^{1.25}$$

$$\log 3.333 = 0.5228$$

$$\log (3.333)^{1.25} = \frac{5}{4} \log 3.333 = 0.6535$$

$$\log \sqrt{3} = \frac{1}{2} \log 3 = \frac{1}{2} (0.4771) = 0.23855$$

$$\log \frac{(3.333)^{1.25}}{\sqrt{3}} = 0.4149 = \log 2.599$$

∴ $n = 260$ to 3 significant figures

EXAMPLES.—XXI.

1. The weight of a cylinder of metal varies as its length and the square of its diameter. A cylinder 10 ins. long and 4 ins. in diameter weighs 30 lbs.; find the weight of a cylinder of the same metal 12 ins. long and 6 ins. in diameter.

2. The weight of a sphere varies as the cube of its diameter. If a sphere of diameter 5 ins. weighs 16 lbs., find the diameter of a sphere which weighs 50 lbs.

3. The electrical resistance of a wire varies as its length, and inversely as the area of its cross-section. The resistance of 1000 yards of No. 7 copper wire of cross-section 15.659 sq. mm. is 1.0056 ohms; find the resistance of 1 mile of No. 10 wire of cross-section 8.301 sq. mm.

4. The force between two magnetic poles varies jointly as their strengths, and inversely as the square of the distance between them. If two poles of strengths 6 and 10 units repel one another with a force of 2.4 dynes when placed 5 cm. apart, with what force will two poles of strengths, 5 and 12, repel one another when placed 7 cm. apart?

5. The heat produced in a conductor of resistance R when a current of strength C passes through it for a time t , varies directly as (1) the square of the current, (2) the resistance, (3) the time. A current of 5 amps. was sent through a wire of 10 ohms resistance for two minutes, and the heat developed was found to be 12,500 units. How

much heat is developed when a current of 7 amps. passes through a resistance of 6 ohms for 3 minutes? How much heat is developed when 1 amp. passes through 1 ohm for 1 second?

6. If a number of sources of light give the same intensity of illumination at any point, the candle power of any source varies as the square of its distance from that point. A photometer screen is placed between a standard lamp of two-candle power and a lamp **A** whose candle-power is required, so that the intensity of the illumination is the same on both sides of the screen. If the screen is 121 cm. from the standard lamp, and 354 cm. from **A**, what is the candle-power of **A**?

7. The resistance F lbs. of the air to the flight of a bullet of diameter d inches at velocity v ft. per sec. may be taken to vary as $d \cdot (v - 800)$, when v is greater than 1100. Given that when $d = 0.303$ in., and $v = 2000$, $F = 1.532$; find F when $d = 0.5$ in., and $v = 1500$.

8. The greatest horse-power that can be transmitted by a rope on a certain pulley varies as $T^{1.5}$, $W^{-0.5}$, where T is the greatest tension, and W the weight of the rope per foot of length. When $T = 918$ lbs., and $W = 0.36$ lbs., the greatest H.P. transmitted is 42.2; find a formula for the greatest H.P. transmitted for any values of T and W .

9. If D inches is the deflection in the middle of a beam, supported at the ends and loaded in the middle, then $D = \frac{1}{48} \frac{Wl^3}{EI}$ where W = load in lbs., l = length (inches), E = modulus of elasticity of beam in pounds per square inch, I = moment of inertia of section.

For a wrought-iron bar of rectangular section, 2 ins. deep and 1 in. wide, $I = \frac{2}{3}$, $E = 29 \times 10^6$. If the supports are 5 ft. apart, find the deflection caused by a load of 2 tons.

10. With the same data find the modulus of elasticity of phosphor bronze, when it is found that a bar 1 in. wide and 2 ins. deep, which is supported at two points 3 ft. apart, is deflected 0.233 in. in the middle by a load of 1 ton.

11. If Q is the maximum quantity in cubic feet per hour of gas of specific gravity G , which can be supplied through pipes of diameter D inches, and length L yards, under a pressure of H inches of water,

$$D \propto Q^{0.4}(GL)^{0.2} H^{-0.2}$$

It is found that a pipe of diameter 1 in., and length 10 yds., will supply 298 cu. ft. per hour of gas of specific gravity 0.45, under a pressure of 0.4 in. of water. Find the maximum quantity in cubic feet per hour of gas of sp. gr. 0.45, which can be supplied through a pipe 100 yds. long and 1.5 in. diameter, under a pressure of 0.75 in. of water.

12. Find the pressure needed to supply 1067 cu. ft. per hour through a pipe 5000 yds. long and 4 ins. in diameter (sp. gr. = 0.45).

13. Calculate the value of $(0.1352)^{-0.03} \times (\cos 35^\circ)^{0.31}$.

14. Calculate the value of $\frac{3.42 \times \sqrt{2.65} \times (1.02)^3}{\cos 31^\circ}$.

15. Evaluate $\sqrt{\cos 31^\circ} \sin 12^\circ + (\log_{10} 151)^{1.3}$.

16. Find the value of ae^{-kt} when $a = 2$, $t = 2.718$, $k = 0.0036$, $t = 15$.

Calculate the value of $ae^{-kt} \sin(\pi t + g)$ for the following cases (the angle $(\pi t + g)$ is measured in radians):—

17. $a = 6$, $k = 300$, $\pi = 500$, $g = 0.1222$, $t = 0.01$.

18. $a = 4$, $k = 300$, $\pi = 500$, $t = 0.001$, $g = -0.1341$ radian.

19. $a = 6$, $k = 400$, $\pi = 1200$, $g = -0.5061$ radian, and $t = 0.01$ and 0.001 respectively.

20. T_1 is the applied force, and T_2 the pull at the fixed end of the band-brake of a bicycle; x is the length of the band in contact with the drum, and the radius of the drum is 2 ins.; μ is the coefficient of friction between the band and the drum.

Then, if the brake is fixed so that the drum rotates towards the fixed end, $T_1 = T_2 e^{\mu x}$.

and if it is fixed so that the rotation is *from* the fixed end, $T_1 = T_2 e^{-\mu x}$. The braking force is the difference between T_1 and T_2 . If $x = 10$ ins., $\mu = 0.54$, and $T_1 = 400$ lbs., calculate and compare the braking forces in the two cases.

21. Calculate the value of

$$r = \left[\frac{\log(n_2 + \sqrt{n_2^2 - 1})}{\log(n_1 + \sqrt{n_1^2 - 1})} \right]^2$$

where $2n_1 = 2.31$; $2n_2 = 2.82$.

22. Calculate the value of the same expression when $2n_1 = 2.14$; $2n_2 = 2.50$.

23. Calculate the value of

$$L = (D + d) \left\{ \frac{\pi}{2} + \theta + \frac{1}{\tan \theta} \right\}$$

given $C = 20$, $D = 6$, $d = 3$, $\sin \theta = \frac{D+d}{2C}$; θ is measured in radians.

24. The pressure and volume of the steam in a cylinder follow the law $p v^{0.9} = C$.

If $p = 6000$ when $v = 1$, calculate the values of p when v has the values 2, 3, and 4 respectively.

25. If $p v^{1.13} = C$, and $p = 100$ when $v = 1$, calculate the values of p when v has the values 2, 3, and 4 respectively.

26. If the pressure p in lbs. per square inch, and the volume v in cubic feet of 1 lb. of saturated steam, are connected by the equation $p v^{1.0640} = 479$, calculate the volume at pressures of 20, 100, and 300 lbs. per square inch respectively.

27. If $p_m = p_1 \frac{1 + \log_e r}{r}$, find the values of p_m when $p_1 = 100$ for the following values of r : 1.333, 1.5, 3, 8, 20.

28. Calculate the values of

$$p_m = p_1 \frac{r^{s-1} - r^{-s}}{s - 1}$$

when $p_1 = 100$, $s = 0.9$, and r has the values 1.333, 1.5, 3, 8, and 20.

29. Given $p v^k = C$, and $p = 1$ when $v = 1$, find the values of v when $p = \frac{1}{2}$, and k has the values 0.9, 1, 1.13 and 1.37 respectively.

30. Calculate the values of p_m from the formula of example 28, when $p_1 = 100$, $s = 1.0646$, and r has the same values as in example 28.

31. Calculate the value of

$$\frac{C}{n+1} (v_2^{n+1} - v_1^{n+1})$$

when $C = 150$, $n = -1.13$, $v_2 = 10$, $v_1 = 2$.

32. Calculate the value of

$$\frac{C}{1-n} \frac{(v_2^{1-n} - v_1^{1-n})}{v_2 - v_1}$$

when $C = 147$, $n = 1.37$, $v_1 = 0.8$, $v_2 = 9$.

33. Calculate the value of

$$U = \left\{ \frac{\gamma}{\gamma-1} p_1 \left(r^{-1} - \frac{1}{\gamma} r^{-\gamma} \right) - p_2 \right\} \left(\frac{A}{p_1} \right)^{\frac{1}{\gamma}} r$$

when $p_1 = 15,210$, $r = 5$, $\gamma = 0.9$, $p_2 = 650$, $p_1 v_1^\gamma = A$, $v_1 = 2$.

34. R is the combined resistance of resistances r_1, r_2, r_3, r_4 in parallel.

$$\frac{1}{R} = \frac{r_2 r_3 r_4 + r_3 r_4 r_1 + r_4 r_1 r_2 + r_1 r_2 r_3}{r_1 r_2 r_3 r_4}$$

What resistance must be put in parallel with resistances of 5.3, 6.2, and 7.1 ohms to give a combined resistance of 1.6375 ohms.

35. Calculate the value of

$$L = \frac{2l}{10^6} \left\{ \log_a \frac{b^2}{a^2} + 1 \right\}$$

given $b = 8$, $a = 0.062$, $l = 350$.

36. Calculate the value of

$$Q = \frac{2}{3} \sqrt{2gb} (h_2^{\frac{3}{2}} - h_1^{\frac{3}{2}})$$

having given $g = 32.2$, $b = \frac{1}{2}$, $h_1 = 1\frac{5}{2}$, $h_2 = 1.5$.

37. The entropy ϕ of one pound of water at absolute temperature t° C. is given by the formula

$$\phi = 1.0565 \log_a \frac{t}{273.7} + 9 \times 10^{-7} \left(\frac{t^2}{2} - 502.96t \right) + 0.0902$$

Calculate the values of ϕ when t has the values 273.7, 303.7, 333.7, 363.7.

38. The entropy ϕ of one pound of dry saturated steam at absolute temperature t° C. is given by the formula

$$\phi = \log_a \frac{t}{273.7} + \frac{797}{t} - 0.695$$

Find the value of ϕ when $t = 413.7$.

39. If $\phi = 0.737 \log_a \frac{t}{274} + 2.875 \times 10^{-6}(t^2 - 1096t) + 0.648$

calculate ϕ when $t = 500$.

40. The following formulæ are used to calculate the entropy ϕ of one pound of air at pressure p , volume v , and absolute temperature t° F. :—

$$\phi = 0.1688 \log_a \frac{t}{2116} + 0.2375 \log_a \frac{v}{12.39}$$

$$\phi = 0.2375 \log_a \frac{t}{493} - 0.0687 \log_a \frac{p}{2116}$$

$$\phi = 0.1688 \log_a \frac{t}{493} + 0.0687 \log_a \frac{v}{12.39}$$

p , v , and t are connected by the equation $p v = R t$.

If $R = 53.2$, and $p = 6318$, when $v = 6.195$, calculate the value of ϕ when $v = 6.195$.

41. Also calculate t , and from this find the values of ϕ given by the second and third formulæ. Verify that the three values thus found are the same.

43. Compound Interest.—To find a formula for the amount $\mathcal{L}A$ of $\mathcal{L}P$ invested for n years at r per cent. per annum, compound interest, payable annually.

At the end of the first year each $\mathcal{L}100$ invested has become $\mathcal{L}(100 + r)$, and therefore each $\mathcal{L}1$ invested has become $\mathcal{L}\left(1 + \frac{r}{100}\right)$. Thus the amount at the end of the first year is $\mathcal{L}\left(1 + \frac{r}{100}\right)P$.

This is the principal for the second year. In the same way it follows that after this has been invested for another year it becomes

$$\left(1 + \frac{r}{100}\right) \times \left(1 + \frac{r}{100}\right)P$$

i.e. the amount at the end of two years is

$$\left(1 + \frac{r}{100}\right)^2 P$$

Similarly the amount at the end of three years is

$$\left(1 + \frac{r}{100}\right)^3 P$$

And the amount at the end of n years is

$$A = \left(1 + \frac{r}{100}\right)^n P$$

EXAMPLE.—Find the number of years in which £400 will amount to £600 at 3 per cent. compound interest.

We have $P = 400$, $r = 3$, $A = 600$; to find n .

$$A = \left(1 + \frac{r}{100}\right)^n P$$

$$600 = \left(\frac{103}{100}\right)^n 400$$

$$\therefore (1.03)^n = \frac{600}{400} = 1.5$$

Taking logs we have

$$n \log (1.03) = \log 1.5$$

$$\therefore n = \frac{\log 1.5}{\log 1.03} = 0.1761$$

$$= 13.75 \text{ years}$$

EXAMPLES.—XXII.

1. Find the compound interest on £227 for $3\frac{1}{2}$ years, at $4\frac{1}{2}$ per cent. per annum.
2. Find the amount of £1560 in 4 years, at $2\frac{1}{2}$ per cent. compound interest.
3. What is the compound interest on £135 for 5 years, at 3 per cent.?
4. At what rate per cent. would £140 gain £20 in 12 years, at compound interest?
5. How long will it take £100 to gain £50 compound interest, at $2\frac{1}{2}$ per cent.?
6. At what rate per cent., compound interest, will £100 gain £50 in 25 years?
7. How long will it take £129 to gain £13 at 5 per cent. compound interest?
8. A certain rare book cost $1\frac{1}{2}d.$ in 1620, and in 1900 was worth £100. Was this a gain or loss on its original price, supposing that the $1\frac{1}{2}d.$ could have been invested at 5 per cent. compound interest. Find the amount of the gain or loss to the nearest pound.
9. Find a formula for the amount of £P in n years at r per cent. per annum, simple interest.
10. The sum of £ m is invested in r per cent. stock at £ n per £100 share. Find a formula for the rate of interest obtained on the sum invested. Neglect brokerage.
11. Find a formula for the true discount D on a bill of £A due n months hence at r per cent. per annum, simple interest.
12. Find a formula for the difference x between the true and the banker's discount in example 11.
13. The present value of an annuity of £ a per annum for n years at r per cent. compound interest, is

$$P = \left\{1 - \left(\frac{100}{100 + r}\right)^n\right\} \frac{100a}{r}$$

Find the present value of an annuity of £52 per annum for 20 years, with compound interest at 3 per cent.

14. Find the present value of an annuity of £100 per annum for 30 years, with compound interest at $2\frac{1}{2}$ per cent.

15. The average expectation of life of a man of 60 is 13 years. What life annuity can he buy for £1000 with compound interest at $2\frac{1}{2}$ per cent. Neglect the profits of the insurance company.

16. A man of 60 has an average expectation of life of 13 years; what will it cost him to buy an annuity of £100 a year for the remainder of his life with compound interest at $2\frac{1}{2}$ per cent.?

17. y is the cost price of a machine which will last n years. There is also a more durable machine which will last N years. If i is the interest on £1 for 1 year expressed as the decimal of a pound, the price x which may be paid for the more durable machine, so that it may be as cheap as the former in the long run, is given by the formula

$$x = y \frac{(1+i)^N - 1}{(1+i)^N - (1+i)^{N-n}}$$

If a machine which lasts 5 years costs £180, how much should be paid for a machine which will do the same work and last 20 years, taking interest on capital at 4 per cent.?

44. **Formulæ in Mensuration.**—The following list of formulæ in mensuration is given here for reference, the proofs of the simpler formulæ are assumed to be known to the student, proofs of others will be given at a later stage.

The references are to the proofs.

$$\begin{aligned} \text{Area of a triangle} &= \frac{1}{2}(\text{base}) \times (\text{height}) \\ &= \frac{1}{2}ab \sin C \\ &= \sqrt{s(s-a)(s-b)(s-c)} \end{aligned}$$

$$\text{where } s = \frac{a+b+c}{2} \dots \dots \dots (\S 29.)$$

$$\text{Area of a trapezium} = \text{half the sum of the parallel sides multiplied by the perpendicular distance between them} = h \cdot \frac{AD + BC}{2}.$$

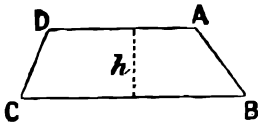

FIG. 34.

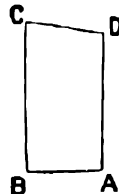

FIG. 35.

In particular for the case where the two parallel sides are perpendicular to the base AB

$$\text{Area} = (\text{base}) \times (\text{mean height}) = AB \times \frac{AD + BC}{2}.$$

$$\text{Circumference of circle of radius } r = 2\pi r$$

$$\text{Arc of a circle subtended by an angle of } \theta \text{ radians at the centre} = r\theta$$

$$\text{Huygen's Rule.}—\text{Length of arc of a circle} = \frac{8\phi - c}{3} \text{ approximately}$$

where ϕ = chord of half the arc,

c = chord of whole arc.

$$\text{Area of a circle} = \pi r^2,$$

$$\text{Area of sector of a circle} = \frac{1}{2}r^2\theta.$$

Area of segment ABC = area of sector OACB - area of triangle OAB
 = $\frac{1}{2}r^2(\theta - \sin \theta)$.

Area of segment less than a semicircle = $\frac{h^3}{2c} + \frac{2}{3} \cdot h$ approximately,
 where h = height of segment.

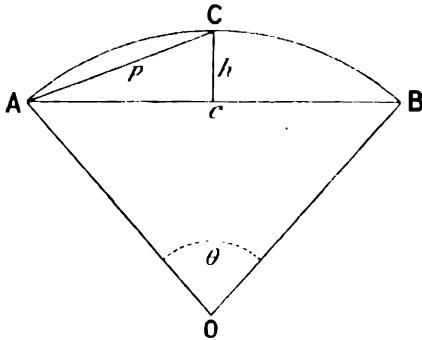

FIG. 36.

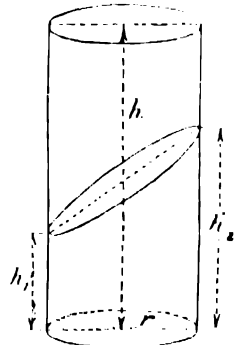

FIG. 37.

Area of curved surface of right circular cylinder = $2\pi r h$.

Volume of right circular cylinder = $\pi r^2 h$.

Volume of frustum of cylinder = $\pi r^2 \frac{h_1 + h_2}{2}$.

Volume of pyramid = $\frac{1}{3}$ (area of base) \times (vertical height)

For the case of a right circular cone this becomes $\frac{1}{3}\pi r^2 h$

= $\frac{1}{3}$ (volume of cylinder of the same height on the same base) . § 199

Volume of frustum of pyramid = $\frac{h}{3}(A + \sqrt{AB} + B)$

where h = height of frustum, and A and B are the areas of the two parallel faces

For the frustum of a cone $A = \pi r_1^2$; $B = \pi r_2^2$

and volume = $\frac{\pi h}{3}(r_1^2 + r_1 r_2 + r_2^2)$ § 199

where r_1 and r_2 are the radii of the parallel circular faces.

Area of curved surface of cone = $\frac{1}{2}$ (perimeter of base) \times (slant height)
 = $\pi r l$

where r = radius of base and l = slant height.

Area of curved surface of frustum of cone = $\pi l(r_1 + r_2)$.

Volume of sphere = $\frac{4}{3}\pi r^3$

where r = radius § 199

Area of surface of sphere } = $4\pi r^2$

= area of curved surface of circumscribing cylinder

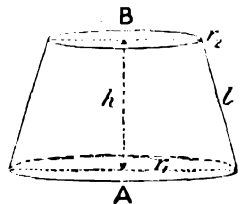

FIG. 38.

Volume of zone of sphere = $\frac{\pi h}{6} \{3(r_1^2 + r_2^2) + h^2\}$

where r_1 and r_2 are the radii of the circular faces.

For the case $r_1 = 0$ we get the volume of a segment

$$\frac{\pi h}{6}(3r_1^2 + h^2)$$

Surface of zone of sphere = $2\pi rh$ (where r = radius of sphere)
 = area of curved surface of circumscribing cylinder of the same height

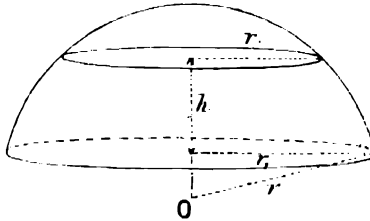

FIG. 39.

If a circle of radius r revolves round a straight line in its plane, so that its centre traces out a circle of radius R , the solid which it traces out is called an **anchor ring**.

Volume of anchor ring = $2\pi^2 r^2 R$

Area of surface of anchor ring = $4\pi^2 Rr$ § 210

EXAMPLES.—XXIII.

1. What is the diameter of a circular lake whose area is 3 acres?
2. A running track is in the form of a circular ring. Its outside diameter is 350 yds., and it is 6 yds. wide. What is its area?
3. Find the area of a sector of a circle of radius 3 ft., and angle 56° .
4. Find the area of a sector of a circle of radius 2 ft., and angle 154° .
5. A pyramid stands on a rectangular base 2 ins. by 3 ins., and is 10 ins. high. Find its volume.
6. The radii of the circular faces of a frustum of a cone are 3 ft. and 4 ft., and its height is 5 ft. Find its volume.
7. With a radius of 6 ins. describe an arc of a circle of which the chord is 5 ins. long. Measure the required quantities and calculate the length of the arc by the two given formulae. Compare the results.
8. A dome is in the form of a segment of a sphere of radius 100 ft. The height of the dome is 80 ft. How many square feet of lead would be required to cover it?
9. A basin is in the form of a zone of a sphere. The bottom is a circle of radius 3 ins., the top a circle of radius 9 ins., and the depth of the basin is 5 ins. How much water will it hold?
10. A piece of sheet zinc in the form of a rectangle measuring 12 ins. by 9 ins., is found to weigh 0.787 lbs. What is its thickness? Zinc weighs 0.252 lb. per cubic inch.
11. Copper wire of size No. 5, S.W.G., weighs 718 lbs. per mile: find the area of its cross-section and its diameter. Copper weighs 555 lbs. per cubic foot.
12. Find the weight per foot of a lead pipe of $1\frac{1}{2}$ in. bore and $\frac{1}{8}$ in. thick. One cubic foot of lead weighs 711.6 lbs.
13. A lead pipe of 1 in. bore weighs 2.193 lbs. per foot length. Find the thickness of the metal.
14. What is the thickness of a lead pipe of $2\frac{1}{2}$ ins. internal diameter if it weighs 7.862 lbs. per foot length?
15. Find the weight of an iron pipe 12 ft. long, 14 ins. external diameter, 1 ft. internal diameter. Weight of 1 cu. in. = 0.27 lb.

16. A cast-iron pipe 1'3 ft. long, of 10-in. bore, and $\frac{7}{8}$ in. thick, weighs 121'4 lbs. What is the weight of a cubic inch of cast-iron?

17. A tube of 8 ins. internal diameter is made of copper 0'232 in. thick. It weighs 23'1 lbs. per foot length. Calculate the weight of a cubic foot of copper.

18. The inside diameter of a wrought-iron gas-pipe is 4 ins. It is 4 ft. long, and weighs 31'48 lbs. Given that wrought-iron weighs 0'28 lb. per cu. inch, find its outside diameter.

19. Water flows at the rate of 4'96 ft. per second through a cylindrical pipe of 11 ins. diameter. What is the supply in gallons per minute? $6\frac{1}{4}$ galls. = 1 cu. ft.

20. The outside diameter of a roller is 3 ft., and its outside width 4 ft. The metal is 2 ins. thick on the curved surface. It is closed at the ends which are plane, and 1 in. thick. The axle and handle weigh 11 lbs., and the metal of which the roller is made weighs 437 lbs. per cubic foot. Find the weight of the roller.

21. How many bricks will be required to line the sides of a well 30 ft. deep and 4 ft. in diameter? Each brick measures 9 ins. by $4\frac{1}{2}$ ins. by 3 ins., including mortar, and the lining is to be $4\frac{1}{2}$ in. thick.

22. What is the weight of a hollow steel pillar 10 ft. long, whose external diameter is 5 ins., and internal diameter 4 inches? What is the diameter of a solid pillar of the same weight and length? 1 cu. ft. of steel weighs 499 lbs.

(Board of Education Examination in Naval Architecture, 1902.)

23. A glass tube is 15 cm. long, and its outside diameter is 4 mm. It weighs 4 grms. What is its inside diameter if 1 c.c. of glass weighs 2'52 grms.?

24. A single core electric cable consists of a cylindrical copper wire, surrounded by a coating of insulation, and an outer coating of lead. The area of the cross-section of the copper is 0'25 sq. in., the thickness of the insulation is 0'11 in., and the thickness of the outer covering is 0'11 in. What is the diameter of the whole cable?

If 1 cu. in. of copper weighs	0'32 lb.
„ „ lead weighs	0'41 „
„ „ insulation weighs	0'034 „

find the weight per foot of the cable.

25. Find the weight of a segment of a sphere of lead. Height of segment = 3 ins.; radius of base = 10 ins. 1 cu. in. of lead weighs 0'408 lb.

26. A hollow sphere of brass is found to weigh 50 lbs. Its external diameter is 10 ins.; what is its internal diameter? 1 cu. in. of brass weighs 0'3 lb.

27. A hollow sphere of cast-iron weighs 100 lbs. Its inside diameter is 0'66 of its outside diameter. Find its inside and outside diameters. 1 cu. in. of cast-iron weighs 0'26 lb.

28. Find the area of the total surface of the frustum of a cone; radius at base = 5 ins., radius at top = 3 ins., length of slant side = 4 ins.

29. How many square inches of tin will be required to make a cylindrical can 4 ins. high to hold 1 quart = 0'0401 cu. ft.? There is no lid.

30. A milk can is 6 ins. high, and has a diameter of 4 ins. at the bottom. What is its diameter at the top if it holds 1 quart?

31. A railway embankment is 12 ft. high, the top is 28 ft. wide, and the sides have a slope of 1 in 2 to the horizontal. How many cubic feet of earth are needed to make 100 ft. of the embankment?

45. **Approximation—Product of two Binomial Factors.**—We know that—

$$(1 + x)(1 + y) = 1 + x + y + xy$$

Consider a case where $x = \frac{1}{1000}$ and $y = \frac{2}{1000}$.

Then $xy = \frac{2}{10^6}$ and is very small compared with x and y , and may therefore be neglected if we only require our result to be correct to an accuracy of, for example, one part in one thousand.

Thus we may take $1 + x + y$ as the approximate value of $(1 + x)(1 + y)$ when x and y are small.

EXAMPLE.—The two sides a and b , and the angle C , of a triangle are observed, and the area calculated by means of the formula, $\text{Area} = \frac{1}{2} ab \sin C$.

If the observed value of a is $2\frac{1}{2}$ per cent. too large, and the observed value of b $1\frac{1}{2}$ per cent. too small, what is the resulting error in the calculated value of the area?

Here we have taken $(1 + 0.025)a$ instead of the true value of a , and $(1 - 0.015)b$ instead of the true value of b ; i.e. we have taken $(1 + 0.025)(1 - 0.015)ab$ instead of ab . This is approximately equal to $(1 + 0.025 - 0.015)ab = (1 + 0.01)ab$, since the errors in a and b are both small. Therefore the calculated value of the area is, approximately, 1 per cent. too large.

The error introduced by neglecting the term xy is here $0.000375ab$, or about 0.04 per cent., and may be neglected, as it is extremely unlikely that the errors in a and b are known to this degree of accuracy.

By multiplication we have

$$(1 + x)(1 + y)(1 + z) = 1 + x + y + z + xy + yz + zx + xyz$$

and if x , y and z are sufficiently small, the last four terms may be neglected in comparison with the first four, and we have

$$(1 + x)(1 + y)(1 + z) = 1 + x + y + z \text{ approximately}$$

If this result is applied to the case of small errors, as in the last example, we may state it in words as follows:—

If there are small errors in each of three quantities, the resulting error in their product is the sum of the separate errors.

This result applies whether the errors are positive or negative.

This method of proof may be extended to the case of more than three quantities, and it can be shown in the same way that, if there are small errors in each of n quantities, the resulting error in their product is the sum of the errors in the separate quantities, taken with their proper signs.

If there is the same small error x in each of n quantities it follows that the resulting error in their product is nx approximately.

This is equivalent to the statement that

$$(1 + x)(1 + x)(1 + x) \dots \text{to } n \text{ factors} = (1 + x)^n = 1 + nx \text{ approximately}$$

We have here taken n to be a whole number. It can also be shown that if x is less than 1, as it must be when it denotes a small error, the statement that $(1 + x)^n = 1 + nx$ approximately is also true when n is negative or fractional.

The result of this paragraph may be applied to the calculation of fractional or negative powers of certain numbers.

EXAMPLE (1).—To find the value of $\sqrt[3]{145}$.

$$\begin{aligned} \text{We have } \sqrt[3]{145} &= \{144(1 + \frac{1}{144})\}^{\frac{1}{3}} = 12(1 + \frac{1}{144})^{\frac{1}{3}} \\ &= 12(1 + \frac{1}{3} \times \frac{1}{144}) \text{ approximately} \\ &= 12(1 + \frac{1}{432}) = 12 + \frac{1}{36} = 12.0416 \end{aligned}$$

This agrees to four places of decimals, with the value of $\sqrt[3]{145}$ found in the ordinary way.

EXAMPLE (2).— $(1.02)^6 = 1 + 6 \times 0.02$ approximately
 $= 1.12$

EXAMPLE (3).— $\frac{1}{1.015} = (1.015)^{-1}$

Here $x = 0.015$, and $n = -1$
 $\therefore (1.015)^{-1} = 1 - 0.015 = 0.985$ approximately

EXAMPLE (4).— $\frac{1}{\sqrt{0.998}} = (1 - 0.002)^{-\frac{1}{2}}$
 $= 1 + (-\frac{1}{2})(-0.002)$ approximately
 $= 1.001$

EXAMPLE (5).—Find the approximate value of

$$y = \frac{1.002 \times 0.996}{2.008}$$

$$y = \frac{1}{2}(1 + 0.002)(1 - 0.004)(1 + 0.004)^{-1}$$

$$= \frac{1}{2}(1 + 0.002 - 0.004 - 0.004)$$

$$= \frac{1}{2}(1 - 0.006) = 0.497$$
 approximately

The student should work out the value of y to 6 decimal places, and find the error in the above approximation.

EXAMPLE (6).—The radius of a circle is found by measurement to be 3.26 ins., and the area is calculated from this value. If there is a possible error of 2 per cent. in the observed value of the radius, what is the possible error in the calculated value of the area?

If r is the radius, the area = πr^2 .

An error of 2 per cent. in r has the effect of multiplying r by (1 ± 0.02) , and therefore of multiplying πr^2 by $(1 \pm 0.02)^2 = 1 \pm 0.04$ approximately.

i.e. there is a possible error of 4 per cent. = $0.04 \times \pi \times 3.26^2$
 $= 1.33$ sq. in.

in the calculated value of the area of the circle.

EXAMPLE (7).—In finding the torsional rigidity of a wire by observing its torsional oscillations we make use of the formula

$$n = \frac{2\pi I l}{l^2 r^4}$$

If errors are made of

- 0.2 per cent. too little in the observed value of l ,
- 2 per cent. too much in the observed value of l ,
- and 3 per cent. too much in the observed value of r ,

what is the resulting error in the calculated value of n ?

The true value of

l is multiplied by $(1 - 0.002)$ to obtain the observed value,
 that of l " " $(1 + 0.02)$ " "
 " r " " $(1 + 0.03)$ " "

\therefore the true value of n is multiplied by $\frac{1 - 0.002}{(1 + 0.02)^2(1 + 0.03)^4}$
 $= (1 - 0.002)(1 + 0.02)^{-2}(1 + 0.03)^{-4}$
 $= 1 - 0.002 - 2(0.02) - 4(0.03)$ approximately
 $= 1 - 0.162$

i.e. there is an error of 16.2 per cent. too little in the calculated value of n .

EXAMPLES.—XXIV.

1. Calculate the value of 1.01×1.025 by the approximate method used in the preceding examples, and also by multiplying in full, and find the error of the approximate method.

2. Calculate the value of $\frac{1.025}{1.015}$ by the approximate method, and also by actual division to 6 decimal places, and find the error of the approximate method.

3. Find the value of $1.002 \times 1.0018 \times 0.996$, correct to 4 decimal places.

Find approximate values of the following quantities:—

- | | | | |
|--------------------------|--------------------------|--------------------------|--|
| 4. $\frac{0.996}{1.002}$ | 5. $\frac{1.003}{0.997}$ | 6. $\frac{0.993}{1.005}$ | 7. $\frac{1.0023 \times 0.9984}{1.0016}$ |
| 8. $\sqrt[3]{0.98}$ | 9. $\sqrt{1.02}$ | 10. $\sqrt{102}$ | 11. $\sqrt{254}$ |
| 12. $\sqrt{730}$ | 13. $\sqrt{224}$ | 14. $\sqrt[3]{217}$ | 15. $\sqrt[3]{728}$ |
| 16. $\frac{1}{98}$ | 17. $\frac{1}{506}$ | 18. $\frac{1}{1.009}$ | |

19. An error of 1.5 per cent. excess is made in measuring the side a of a triangle and an error of 1.8 per cent. defect in measuring the side b . What is the resulting percentage error in the area as calculated from the formula $\frac{1}{2} ab \sin C$?

20. If there is an error of 5 lbs. in the value of the weight of 1 mile of copper wire given in example 11, p. 58, what is the resulting error in the calculated value of its diameter?

21. If the length of the seconds pendulum is increased by $\frac{1}{1000}$ part, how many seconds will the clock lose in a day? The time T of a complete oscillation of a pendulum is equal to $2\pi \sqrt{\frac{l}{g}}$, where l is the length and g is a constant quantity.

22. The radius of a sphere is found by measurement to be 5 ins. What error will be caused in the calculated value of the volume by an error of 1 per cent. in the measured value of the radius?

23. The value of g is found, from the formula $T = 2\pi \sqrt{\frac{l}{g}}$. T is the time of a complete oscillation, and l the length of a pendulum. What will be the error per cent. in the calculated value of g if the observed value of T is 1 per cent. too large?

24. If power U ft. lbs. per second is transmitted over a distance l ft., by water at a pressure of p lbs. to the square foot, along a pipe of radius r ft.; then

$$\frac{\text{loss of energy}}{\text{energy put in}} = \frac{AU^2}{r^3 p^3}$$

What is the effect on this ratio of an increase of 5 per cent. (a) in the pressure, (b) in the radius of the pipe?

25. If v c.c. per second of a liquid of specific gravity s flow through a capillary tube of radius r and length l , under a pressure of H cm. of the liquid, the viscosity η of the liquid is given by

$$\eta = \frac{\pi H r^4 s}{8 v l}$$

What percentage errors are caused in the calculated value of η by errors of 1 per cent. in the observed values of r , H , and v respectively?

26. The value M of the magnetic moment of a magnet is calculated from the two formulæ

$$T = \sqrt{\frac{I}{MH}} \quad \text{and} \quad \frac{M}{H} = \frac{(d^2 - l^2)^2}{2d} \tan \theta$$

I , d , l , θ and T are observed quantities. If an error of 2 per cent. excess is made in observing the value of T , and all the other readings are correct to 0.1 per cent., what is the approximate error per cent. in the calculated value of M ?

40. **Units.**—The exact expression of a physical quantity consists of two parts—the unit in terms of which it is measured, and the measure expressing the number of times the unit is contained in the quantity: e.g. we speak of a certain length as 5 ft. or 152.4 cm.; in the first case 5 is the measure and

one foot is the unit, in the second case 152·4 is the measure and one centimetre is the unit. We speak of a certain velocity as 15 ft. per second, or 457·2 cm. per second : in the first case 15 is the measure and one foot per second is the unit of velocity ; in the second case 457·2 is the measure and one centimetre per second is the unit.

Note that the measure of a given quantity varies inversely as the unit in terms of which it is measured. In the first example above, when the unit of length is changed from 1 ft. to 1 cm., *i.e.* the unit is divided by 30·48, then the measure of the given length is multiplied by 30·48.

47. Dimensions of Units.—The various units used in mechanics, with the exception of the unit of temperature as measured by expansion and those units which depend upon it, may be ultimately defined in terms of the three units of **length, time, and mass.**

These are called the three fundamental units. Thus, for example, the unit of velocity is the velocity of a point which moves through the unit of length along a straight line in the unit of time. We denote the three fundamental units of mass, length, and time by the symbols [M], [L], and [T].

If the fundamental units are changed, all other units which depend upon them will in general be changed as well.

The unit of velocity, for example, will evidently be changed in the same ratio as the unit of length, and inversely as the unit of time.

We express this by saying that the *dimensions* of the unit of velocity are $\left[\frac{L}{T}\right]$.

Similarly, since the unit of acceleration is the acceleration of a point moving so that its velocity increases by unit velocity in unit time, its dimensions are

$$\left[\frac{L}{T^2}\right]$$

In general, when any unit varies as the *n*th power of a fundamental unit, we say that it is of *n* dimensions in that unit.

Thus, for example, the unit of volume is the volume of a cube whose edge is the unit of length and its dimensions are $[L^3]$.

The unit force causes unit mass to move with unit velocity, its dimensions are $\left[\frac{ML}{T^2}\right]$.

As an example, the student may verify the following statements from his knowledge of mechanics :—

The dimensions of the unit of work or energy are $\left[\frac{ML^2}{T^2}\right]$

The dimensions of the unit of power are $\left[\frac{ML^2}{T^3}\right]$

The dimensions of the unit of momentum are $\left[\frac{ML}{T}\right]$

Those units which are directly derived from the fundamental units are called **absolute units.** In some cases the absolute unit is too small for practical use, and a special practical unit has to be used.

E.g. 1 ft.-lb. per second is the absolute unit of power when 32·2 lb., 1 ft., and 1 second are the fundamental units ; but, as this unit is small, the horse-power, which is equal to 550 such units, is used instead for practical purposes. One erg per second is the absolute unit of power when 1 gm.,

1 cm., and 1 second are the fundamental units ; as this unit is very small, the watt, which is equal to 10^7 such units, is used for practical purposes.

EXAMPLE.—*The practical unit of power in applied mechanics is 1 horse-power, in electricity it is 1 watt. Find the number of watts in a horse-power.*

In changing from the first system of fundamental units to the second,

[M] is multiplied by $\frac{1}{32.2 \times 453.6}$, since there are 453.6 grms. in a pound ;

[L] is multiplied by $\frac{0.3937}{12}$, since 1 cm. = 0.3937 in. ;

[T] is unchanged ;

The dimensions of the unit of power are $\left[\frac{ML^2}{T^3}\right]$

∴ the absolute unit of power is multiplied by $\frac{1}{32.2 \times 453.6} \times \left(\frac{0.3937}{12}\right)^2$ in

changing from the foot, 32.2 lb., sec. system to the cm., gm., sec. system.

550 is the measure of one horse-power in the first system of absolute units, and, since the measure of a given quantity varies inversely as the unit in which it is measured, the measure of one horse-power in ergs per second is

$$\begin{aligned} 550 \times \frac{32.2 \times 453.6 \times 12^2}{(0.3937)^2} &= 7.46 \times 10^9 \text{ ergs per second} \\ &= 746 \text{ watts.} \end{aligned}$$

EXAMPLES.—XXV.

1. One erg is the absolute unit of work when 1 gm., 1 cm., and 1 sec. are the fundamental units ; one foot-pound is the absolute unit of work when 32.2 lbs., 1 ft., and 1 sec. are the fundamental units. Find the number of ergs in a foot-pound.

2. One pound is the absolute unit of force when 32.2 lbs., 1 ft., and 1 sec. are the fundamental units ; one dyne is the absolute unit of force in the cm., gm., sec. system. Find the number of dynes in a pound.

3. The modulus of torsion of steel is 8253 kilogs. per sq. mm. ; what is it in tons per square inch ?

4. The measure of the acceleration due to gravity is 32.2 absolute units when 1 ft. and 1 sec. are the fundamental units. Find the measure of this acceleration when 1 cm. and 1 sec. are the fundamental units,

CHAPTER VI

MISCELLANEOUS EQUATIONS AND IDENTITIES

48. IN this chapter we shall deal with certain portions of elementary algebra which are of importance in the applications of the subject. This treatment is intended to supplement and not to take the place of ordinary text-books in algebra.

49. Quadratic Equations.—To find a formula for the values of x which satisfy the quadratic equation.

$$ax^2 + bx + c = 0$$

where a , b , and c are any constant quantities.

$$\text{We have } x^2 + \frac{b}{a}x = -\frac{c}{a}$$

Add $\frac{b^2}{4a^2}$ to both sides of this equation

$$\text{Then } x^2 + \frac{b}{a}x + \frac{b^2}{4a^2} = -\frac{c}{a} + \frac{b^2}{4a^2}$$

$$\text{i.e. } \left(x + \frac{b}{2a}\right)^2 = \frac{b^2 - 4ac}{4a^2}$$

$$\therefore x + \frac{b}{2a} = \frac{\pm \sqrt{b^2 - 4ac}}{2a}$$

$$\text{and } x = \frac{-b \pm \sqrt{b^2 - 4ac}}{2a} \quad \dots \dots (1)$$

This formula gives the two roots of the quadratic equation

$$ax^2 + bx + c = 0 \text{ for any values of } a, b, \text{ and } c$$

E.g. Let $3x^2 + 2x - 4 = 0$

$$\text{Here } a = 3, b = 2, c = -4$$

$$\text{and } \therefore x = \frac{-2 \pm \sqrt{4 + 48}}{6}$$

$$= \frac{-1 \pm \sqrt{13}}{3} = -1.535 \text{ or } 0.868$$

50. Conditions for Real, Equal, and Imaginary Roots.—In the above example we had no difficulty in calculating the roots, because the quantity $b^2 - 4ac$, under the square root was positive, and its square root could be found. It may happen that $b^2 - 4ac$ is negative; *i.e.* b^2 is less than $4ac$, as in the following example:—

$$3x^2 + 2x + 4 = 0$$

Substituting in the formula (1) we find

$$x = \frac{-2 \pm \sqrt{4 - 48}}{6} = \frac{-1 \pm \sqrt{-11}}{3}$$

Since we cannot find any real number whose square is -11 , the roots of this equation are said to be imaginary.

We shall find, however, at a later stage, that for certain purposes we may use the imaginary roots of an equation as if they were real, and that, in the applications of the subject, the results have a definite physical meaning.

We may write the above expression for the value of x

$$x = \frac{-1 \pm \sqrt{11} \times \sqrt{-1}}{3} = -0.33 \pm 1.105i$$

where i is used to denote $\sqrt{-1}$.

If b^2 is equal to $4ac$ the quantity $b^2 - 4ac$ under the square root in (1) vanishes, and the two roots of the quadratic equation become equal, e.g. :—

$$4x^2 - 20x + 25 = 0$$

Substituting in (1) we get

$$x = \frac{20 \pm \sqrt{400 - 400}}{8} = 2.5 \pm 0$$

i.e. the two roots of the equation are each equal to 2.5.

Note that in this case $ax^2 + bx + c$ is an exact square.

We have thus shown that in the equation

$$ax^2 + bx + c = 0$$

If b^2 is greater than $4ac$ the roots are real and unequal ;

If b^2 is less than $4ac$ the roots are imaginary ;

If b^2 is equal to $4ac$ the roots are real and equal.

EXAMPLES.—XXVI.

Find the values of x which satisfy each of the following equations, correct to two places of decimals :—

- | | | |
|--|-----------------------------|--------------------------------|
| 1. $2x^2 - 3x + 1 = 0$. | 2. $3x^2 + 10x + 2 = 0$. | 3. $5x^2 - 4x - 6 = 0$. |
| 4. $3x^2 + 5x - 8 = 0$. | 5. $3 - 2x - 4x^2 = 0$. | 6. $3x - 4 - 5x^2 = 0$. |
| 7. $3x^2 - x + 4 = 0$. | 8. $23x^2 + 13x + 11 = 0$. | 9. $1.3x^2 - 2.5x + 5.9 = 0$. |
| 10. $2.5 \times 10^{-2}x^2 + 2.1 \times 10^2x + 4 \times 10^6 = 0$. | | |
| 11. $2.5 \times 10^{-2}x^2 + 2 \times 10^2x + 4 \times 10^6 = 0$. | | |
| 12. $2.5 \times 10^{-2}x^2 + 1.9 \times 10^2x + 4 \times 10^6 = 0$. | | |

51. Solutions of Equations by Resolutions into Factors.—Let α and β be the roots of the equation

$$ax^2 + bx + c = 0$$

then $\alpha = \frac{-b + \sqrt{b^2 - 4ac}}{2a}$; $\beta = \frac{-b - \sqrt{b^2 - 4ac}}{2a}$

From these values we get

$$\alpha + \beta = -\frac{b}{a}; \quad \alpha\beta = \frac{b^2 - b^2 + 4ac}{4a^2} = \frac{c}{a}$$

Thus, if any quadratic equation is written in the form $x^2 + \frac{b}{a}x + \frac{c}{a} = 0$, so that the coefficient of x^2 is unity, and all the terms are on the same side of the equation, then the sum of the roots is equal to the coefficient of x with its sign changed, and the product of the roots is equal to the constant term. *E.g.* in the equation

$$x^2 - 5x + 6 = 0,$$

the sum of the roots is 5 and their product 6. We see that the roots must be 3 and 2, and this quadratic equation may be written

$$(x - 3)(x - 2) = 0$$

In general, it follows in the same way that, if α and β are the roots of a quadratic, the equation may be written

$$(x - \alpha)(x - \beta) = 0$$

since we know that in the product of these two factors the coefficient of x is $-(\alpha + \beta)$ and the constant term $\alpha\beta$.

Otherwise, it is evident that if an equation can be put into this form it is satisfied if either factor is zero, *i.e.* if $x = \alpha$ or $x = \beta$, and therefore α and β are the roots.

Thus, when the factors of a quadratic expression can be found by inspection, the roots of the corresponding equation can be written down.

EXAMPLE.—Solve the equation.

$$6x^2 - 11x + 3 = 0$$

We notice that the equation may be written

$$(2x - 3)(3x - 1) = 0$$

This is satisfied either if

$$2x - 3 = 0 \text{ and } x = \frac{3}{2}$$

$$\text{or if } 3x - 1 = 0 \text{ and } x = \frac{1}{3}$$

\therefore the roots of the equation are $\frac{3}{2}$ and $\frac{1}{3}$.

EXAMPLES. XXXVII.

Solve the equations—

- | | | |
|------------------------------|----------------------------|---------------------------|
| 1. $x^2 + 3x + 2 = 0.$ | 2. $x^2 + 2x - 3 = 0.$ | 3. $x^2 + 2x + 1 = 0.$ |
| 4. $x^2 + 5x + 6 = 0.$ | 5. $2x^2 + 6x - 20 = 0.$ | 6. $3x^2 - 19x + 6 = 0.$ |
| 7. $6x^2 + 3x - 45 = 0.$ | 8. $15x^2 - 36x + 12 = 0.$ | 9. $77x^2 + 57x - 54 = 0$ |
| 10. $65x^2 - 390x + 520 = 0$ | 11. $x^2 + y^2 = 0.$ | 12. $x^4 = m^4.$ |
| 13. In the equation | | |

$$Lx^2 + Rx + \frac{1}{K} = 0$$

suppose R and K are known. Write down the conditions which must be satisfied by the value of L that the roots may be real, equal, or imaginary.

14. Solve the equation in example 13 for the cases when $R = 200$, $K = 0.5 \times 10^{-6}$, and L has the following values :—

- (a) $L = 0.002$; (b) $L = 0.01$; (c) $L = 0.005$.

15. Solve the equation $mx^2 + \frac{1}{h} = 0$.

16. If W , g , and h are known in the equation

$$\frac{W}{g}x^2 + kx + \frac{1}{h} = 0$$

write down the conditions which must be satisfied by the value of k that the equation may have real, equal, or imaginary roots.

17. Solve the equation of the last example for the case when $W = \frac{1}{4}$, $g = 32 \cdot 2$, $h = \frac{1}{2}$, $k = 0 \cdot 02$.

52. Equations of the Degree Higher than the Second.—We shall not here give any general methods for solving equations of degree higher than the second, as the student will probably find the graphic method described in Chapter VII. most suitable for any case with which he may meet.

In certain cases, however, equations of higher degree than the second may be easily solved.

EXAMPLE.— $x^4 - 3x^2 - 4 = 0$.

First solving this as a quadratic in x^2 , we get $x^2 = 4$, and $x^2 = -1$.

The case $x^2 = 4$ gives $x = +2$, or $x = -2$

The case $x^2 = -1$ gives $x = +\sqrt{-1}$, or $x = -\sqrt{-1}$

∴ the four roots of the equation are 2 , -2 , $\sqrt{-1}$, $-\sqrt{-1}$.

We might also proceed as follows: The expression on the left-hand side of the equation may be resolved into factors

$$(x-2)(x+2)(x^2+1) = 0$$

The equation is satisfied if any one of the three factors is equal to zero. Thus the equation is reduced to two equations of the first degree and a quadratic equation. The roots of these are 2 , -2 , $\pm\sqrt{-1}$ as before.

We may in this way extend the method of § 51 to equations of any degree. If the equation is arranged so as to have zero on the right-hand side, and the left-hand side can then be resolved into factors, the equation is satisfied if any one of its factors is equal to zero. Thus the problem is reduced to that of the solution of a number of equations of lower degree than the original equation.

It can be proved that every algebraical expression of the n th degree can be resolved into real factors of the first or second degree; thus the expression $x^4 - 3x^2 - 4$ in the above example has two factors of the first degree and one of the second.

Each factor of the first degree evidently gives a single real root of the corresponding equation. Thus, in the above example, we found two real roots 2 and -2 corresponding to the two factors of the first degree. Each quadratic factor which cannot be further resolved into real factors of the first degree gives two imaginary roots of the original equation; thus, in the above example, the quadratic factor $x^2 + 1$ gives the two imaginary roots $\pm\sqrt{-1}$.

It follows that the imaginary roots of any equation always occur in pairs. It can be shown, conversely, that if there is a real root there must be a corresponding factor of the first degree, and also that an equation of the n th degree has n and not more than n roots, real or imaginary.

No general rule can be given for resolving an expression into factors, but

if one or more roots can be found by inspection, we may take out the corresponding factors of the first degree and the remaining factors may then be more easily found.

EXAMPLE.—Solve the equation

$$x^4 + 2x^3 + 2x^2 - 2x - 3 = 0$$

We notice that this equation is satisfied when we substitute $x = 1$, and therefore 1 is a root and $x - 1$ is a factor. By division we find that the equation may now be written

$$(x - 1)(x^3 + 3x^2 + 5x + 3) = 0$$

The second factor vanishes when we substitute $x = -1$, and therefore contains $x + 1$ as a factor. By division we find that the equation may now be written

$$(x - 1)(x + 1)(x^2 + 2x + 3) = 0$$

Since 2^2 is less than $4 \times 3 \times 1$, the roots of $x^2 + 2x + 3 = 0$ are imaginary, and there are no more real roots. The roots of $x^2 + 2x + 3 = 0$ are $-1 \pm \sqrt{2}i$.

Thus the original equation reduces to two equations of the first degree and a quadratic. The roots are 1, -1 , $-1 + \sqrt{2}i$, $-1 - \sqrt{2}i$.

EXAMPLES.—XXVIII.

Solve the equations

1. $x^3 + x^2 - 10x + 8 = 0$. 2. $x^3 - 7x^2 + 7x + 15 = 0$. 3. $x^3 + x - 2 = 0$
 4. $2x^3 + 7x^2 + 10x + 8 = 0$. 5. $x^4 - 5x^3 + 5x^2 + 5x - 6 = 0$.

53. Logarithmic Solution of Equations.

EXAMPLE (1).—Solve the equation

$$3 \cdot 2x^{23} = 5 \cdot 1x^{11}$$

Dividing by $5 \cdot 1x^{11}$, we get

$$0 \cdot 6275x^{12} = 1$$

Taking logarithms of both sides

$$\begin{aligned} 1 \cdot 2 \log x + \log 0 \cdot 6275 &= 0 \\ 1 \cdot 2 \log x &= -\log 0 \cdot 6275 \\ &= 1 - 0 \cdot 7976 = 0 \cdot 2024 \\ \therefore \log x &= 0 \cdot 1687 \\ \therefore x &= 1 \cdot 47, \text{ or } x = 0 \end{aligned}$$

Note that we have divided out by the factor x^{11} , which gives the root $x = 0$.

EXAMPLE (2).—Solve the equation

$$2 \cdot 53 = 3 \cdot 59^{1 \cdot 2x}$$

Taking logs of both sides

$$\begin{aligned} \log 2 \cdot 53 &= 1 \cdot 2x \log 3 \cdot 59 \\ 0 \cdot 4031 &= 1 \cdot 2x \times 0 \cdot 5551 \\ &= x \times 0 \cdot 6661 \\ \therefore x &= 0 \cdot 605 \end{aligned}$$

EXAMPLES.—XXIX.

Solve the equations—

1. $1 \cdot 2x^{23} = 2 \cdot 3x^{43}$. 2. $3 \cdot 95x^{12} = 7 \cdot 81$.
 3. $3 \cdot 21^{25x} = 8 \cdot 9$. 4. $2 \cdot 41^{-1 \cdot 2x} = 2 \cdot 73^{-4 \cdot 2x}^{15}$

5. Find the value of v_2 to satisfy the equation

$$\frac{C}{n+1} (v_2^{n+1} - v_1^{n+1}) = 220$$

given $C = 200$, $n = -1.13$, $v_1 = 9.3$.

6. If $W = P_2 v_2 \log_e \frac{v_2}{v_1}$, find the value of v_1 having given that $P_2 = 2250$, $v_2 = 10$,

$W = 31,200$.

7. Find a value of V which satisfies the equation $14V^{1.3} = 95(V - 14)^{1.3}$.

8. Find a value of x less than 1 which satisfies the equation

$$\frac{2}{\gamma} x^{\frac{2}{\gamma}-1} - \left(1 + \frac{1}{\gamma}\right) x^{\frac{1}{\gamma}} = 0$$

having given that $\gamma = 1.41$.

54. Simultaneous Equations.—We may require to find the values of two or more quantities, so as to satisfy two or more conditions. It can be proved that, in order to determine the values of any number of unknown quantities, we must have the same number of independent equations. Such equations are called simultaneous equations. It is assumed that the student is familiar with the solution of simple simultaneous equations. We shall here give some examples of types which are often found useful in the applications of algebra to geometry and physics.

EXAMPLE (1).—Find the values of m and c so that the equation $y = mx + c$ may be satisfied when $x = 1$ and $y = -3$, and also when $x = -2$ and $y = 5$.

Substituting in the equation, we have

$$\begin{aligned} -3 &= m + c \\ 5 &= -2m + c \end{aligned}$$

Subtracting, we get

$$3m = -8, \quad m = -\frac{8}{3}$$

and by substitution $c = -\frac{1}{3}$

\therefore the required values are $m = -\frac{8}{3}$, and $c = -\frac{1}{3}$
and the equation is $y = -\frac{8}{3}x - \frac{1}{3}$

Substituting $x = 1$ we get $y = -3$, substituting $x = -2$ we get $y = 5$, thus verifying that the equation now satisfies the required conditions.

EXAMPLE (2).—Find the values of x and y which satisfy the equations

$$y = 3x + 2, \text{ and } y^2 = 3 + 2x^2$$

When, as in this case, one of two equations is of the first degree, we may always eliminate one variable by substitution.

Substituting $3x + 2$ for y in the second equation, we get

$$\begin{aligned} 9x^2 + 12x + 4 &= 3 + 2x^2 \\ 7x^2 + 12x + 1 &= 0 \\ \therefore x &= \frac{-12 \pm \sqrt{144 - 28}}{14} \end{aligned}$$

$$= -0.088 \text{ and } -1.626$$

Substituting these values of x in the first equation, we get $y = 1.736$ and -2.878 .

EXAMPLE (3).— D is the density of dilute sulphuric acid when 100 parts by weight contain S parts of the pure acid.

Find a formula, connecting S and D , of the form

$$S = a + bD + cD^2$$

where a, b, c are constants, having given that

$$D = 1.8, 10 \text{ when } S = 99.20$$

$$D = 1.50 \quad ,, \quad S = 59.70$$

$$D = 1.07 \quad ,, \quad S = 10.19$$

Since the three given pairs of corresponding values must satisfy the required formula, we have, substituting

$$99.2 = a + 1.84b + 3.386c \quad \dots \dots \dots (1)$$

$$59.7 = a + 1.50b + 2.250c \quad \dots \dots \dots (2)$$

$$10.19 = a + 1.07b + 1.145c \quad \dots \dots \dots (3)$$

Subtracting (2) from (1) and (3) from (2), we get

$$39.5 = 0.34b + 1.136c \quad \dots \dots \dots (4)$$

$$49.51 = 0.43b + 1.105c \quad \dots \dots \dots (5)$$

We have now two simultaneous equations to find b and c .

Multiplying (4) by 0.43, and (5) by 0.34, and subtracting, we get

$$0.152 = 0.1126c$$

$$\therefore c = 1.351$$

Substituting in (4) we get

$$0.34b = 39.5 - 1.534 = 37.97$$

$$\therefore b = 111.7$$

Substituting the values of b and c in equation (1), we get

$$a = 99.2 - 205.6 - 4.57 \\ = -110.97$$

$$\therefore \text{the required formula is } S = 111.7D + 1.351D^2 - 110.97$$

To verify, substitute $D = 1.5$; we get

$$S = 59.62$$

which is within 0.1 of the given value.

EXAMPLE (4).— F is the frictional resistance in pounds per square inch in a certain bearing running at a velocity of V ft. per minute.

It is known that F and V are connected by a formula of the form $F = kV^n$, where k and n are constants.

$$\text{If } F = 0.368 \text{ when } V = 105$$

$$\text{and } F = 0.613 \text{ when } V = 314$$

find the values of k and n .

$$\text{We have } F = kV^n \quad \dots \dots \dots (1)$$

Taking logs,

$$\log F = n \log V + \log k \quad \dots \dots \dots (2)$$

For the given values of F and V , we find from the tables that

$$\log F = \bar{1}.566 \text{ when } \log V = 2.021$$

$$\text{and } \log F = \bar{1}.7875 \text{ when } \log V = 2.497$$

Substituting in (2), we get

$$\bar{1}.566 = 2.021n + \log k \quad \dots \dots \dots (3)$$

$$\bar{1}.7875 = 2.497n + \log k \quad \dots \dots \dots (4)$$

Subtracting

$$0.2215 = 0.476n, \text{ and } n = 0.465$$

Substituting this value in equation (3), we find

$$\begin{aligned} \log k &= 1.566 - 0.940 \\ &= 2.626 = \log 0.0423 \\ \therefore k &= 0.0423 \end{aligned}$$

\therefore the required formula connecting F and V is $F = 0.0423 V^{0.465}$

EXAMPLE (5).—A body is raised to a temperature of 20° and then allowed to cool; 100 seconds afterwards its temperature is found to be 11° . If θ is the temperature at time t seconds, and it is known that θ and t are connected by an equation of the form $\theta = ae^{bt}$, where a and b are constants, and $e = 2.718$, find the values of a and b .

$$\text{We have } \theta = ae^{bt} \dots \dots \dots (1)$$

Taking logs,

$$\begin{aligned} \log \theta &= bt \log e + \log a \\ &= 0.4343bt + \log a \dots \dots \dots (2) \end{aligned}$$

It is given that when $t = 0$, $\theta = 20^\circ$, and $\log \theta = 1.3010$; also when $t = 100$, $\theta = 11$, and $\log \theta = 1.0414$.

Substituting in equation (2), we get

$$1.3010 = \log a \dots \dots \dots (3)$$

$$1.0414 = 43.43b + \log a \dots \dots \dots (4)$$

We have here two simultaneous equations to find b and a .

From (3) $a = 20$.

Substituting in (4)

$$43.43b = -0.2596; b = -0.00598$$

\therefore the required equation is $\theta = 20e^{-0.006t}$

EXAMPLES.—XXX.

1. Find the values of x and y , so that the equation $y = mx + c$ may be satisfied when $m = \frac{1}{2}$ and $c = 2$, and also when $m = \frac{1}{3}$ and $c = 2.6$. Verify your result by substitution.
2. Find the values of m and c , so that the equation $y = mx + c$ may be satisfied when $x = 4$ and $y = 7$, and also when $x = 3.5$ and $y = 6.4$.
3. x and y satisfy the equation $ax + by + c = 0$. If $y = -4.5$ when $x = 2$, and $y = -10.5$ when $x = 4$, what is the value of y when $x = 7$.
4. It is given that x, y , and z satisfy the equation

$$\frac{x}{a} + \frac{y}{b} + \frac{z}{c} = 1$$

when $a = 2, b = 3, c = 4$, and also when $a = 1, b = 1, c = 1$. Find an expression for y in terms of x .

5. Find the values of x, y , and z which satisfy the equations

$$\frac{x-2}{3} = \frac{y-1}{2} = \frac{z-1}{5}$$

$$\text{and } 2x + 3y + z = 42.$$

6. Find the values of x and y such that $x^2 + y^2 = 16$, and $y = 3x + 2$.
7. If $y^2 = 16x$, and $y = 3x - 1$, find the values of x and y .
8. $y^2 = 4ax, y = mx + c; m, a$ and c are known constants. Find the relation between c and m , so that these equations may have equal roots in x and equal roots in y .

9. Solve the equations: $3x^2 - 7xy + 2y^2 + 8 = 0$; $y = 3x - 1$.

10. Given $xy = ax + by$, and $y = 6.47$ when $x = 9.3$, $y = 4.50$ when $x = 16.2$. Find the value of y when $x = 11.4$.

11. If $y = a + bx + cx^2$ where a , b and c are constants; and $y = 10.55$ when $x = 2.4$, $y = 54.82$ when $x = 5.9$, $y = 209.7$ when $x = 11.3$: find the value of y when $x = 7.2$.

12. y and x are connected by the equation $y = a + \frac{b}{c+x}$. Find the values of the constants a , b and c , having given that $y = 41.0$ when $x = 0.6$, $y = 31.91$ when $x = 2.1$, $y = 26.45$ when $x = 5.4$.

13. It is known that y varies as some power of x in the following two examples: If $y = 26.8$ when $x = 2.8$, $y = 189.5$ when $x = 8.3$, find the equation connecting y and x .

14. y varies as some power of x ; if $y = 0.4845$ when $x = 3.5$, $y = 0.1180$ when $x = 9.6$, find the equation connecting y and x .

15. Given $y = a + bx^n$, $y = 3.6$ when $x = 0$, $y = 10.46$ when $x = 1.4$, $y = 130.3$ when $x = 3.7$; find the value of y when $x = 2.5$.

16. V is the speed of a certain vessel in knots when the engines are working at P horse-power. Find a formula of the form $P = a + bV^3$, connecting P and V . It is found by experiment that $P = 287$ when $V = 5$, $P = 1856$ when $V = 11$.

17. It is known that p and v are connected by an equation of the form $p^n = C$. If $p = 1577$ when $v = 3.5$, and $p = 447.5$ when $v = 9.6$, find the values of n and C .

18. $p^n = C$, $p = 213$ when $v = 2$, $p = 23.4$ when $v = 10$. Find n and C .

19. In Beauchamp Tower's experiments on friction it was found that the coefficient of friction in a certain bearing was 0.0021 when the speed was 157 ft. per minute, and 0.0036 when the speed was 419 ft. per minute. If the friction varies as some power of the speed, find this power.

20. In Hodgkinson's experiments on the strength of cast-iron pillars, a pillar of $2\frac{1}{2}$ ins. diameter and 10 ft. long was found to break with a load of $65,380$ lbs. When cut down to 7.5 ft. long, a pillar of the same diameter and material was found to break with a load of $100,200$ lbs. If the breaking load varies as some power of the length, find this power.

(Phil. Trans., 1841.)

*21. If $p = a(\theta + b)^\theta$, and $p = 69.21$ when $\theta = 150$, $p = 79.03$ when $\theta = 155$, find the values of a and b .

22.
$$1 - \left(\frac{v_1}{v_2}\right)^{\gamma-1} = 0.55$$

$$p_1 v_1^\gamma = p_2 v_2^\gamma$$

$p_1 = 210$, $v_1 = 2.5$, $v_2 = 10$; find p_2 .

23. If $t v^{\gamma-1} = C_1$, and $p v^\gamma = C_2$, and γ is constant, find the equation connecting t and p .

24. If it is known that $t_1 v_1^{\gamma-1} = t_2 v_2^{\gamma-1}$, and that $1 - \left(\frac{v_1}{v_2}\right)^{\gamma-1} = 0.25$, find t_2 , having given that $t_1 = 350$.

25. The entropy ϕ of a certain quantity of gas at pressure p , volume v , temperature t , is 0 . Its entropy at pressure p_0 , volume v_0 , temperature t_0 , is given by

$$\phi = k \log_e \frac{p}{p_0} + K \log_e \frac{v}{v_0}$$

It is known that $p v = R t$, $p_0 v_0 = R t_0$, $R = K - k$. Express ϕ (1) in terms of volume and temperature; (2) in terms of temperature and pressure.

26. If $y = a e^{bx}$, $y = 24.8$ when $x = 12.5$, and $y = 540$ when $x = 33$; find a and b .

27. $y = a e^{bx}$, $y = 12.66$ when $x = 6.5$, $y = 1.484$ when $x = 15.8$. Find a and b .

28. $W = w e^{\mu \theta}$, $W = 5.35$ when $\theta = 1.5\pi$, $W = 22.9$ when $\theta = 3\pi$. Find the value of μ .

29. μ is the coefficient of friction in a certain bearing at temperature t° F. If

* Examples 21-34 may be postponed to a later stage.

there is a law of the form $\mu = ae^{bt}$ connecting μ and t , find the constants a and b . Given $\mu = 0.0059$ when $t = 110$, and $\mu = 0.0124$ when $t = 70$.

30. V is the voltage at time t across a condenser of capacity K , discharging through a resistance R . $V = Ae^{-\frac{t}{KR}}$, where A is constant. If the condenser is allowed to discharge itself through the insulation resistance R of a certain length of cable, it is found that $V = 100$, when $t = 0$, $V = 55$ when $t = 1800$, $K = \frac{1}{3} \times 10^{-6}$. Calculate the value of R .

31. p is the pressure of saturated steam at absolute temperature $t^\circ \text{C}$. The following values are found by experiment:—

p	1.78	20.80	101.9	lbs. per sq. inch.
t	32.4	38.4	43.9	degrees Centigrade.

$$\text{If } \log_{10} p = A - \frac{B}{t} - \frac{C}{t^2}$$

Find the values of A , B , and C .

32. In some experiments to find the viscosity of a liquid, if s is the distance through which the pointer of an oscillating disc swings at time t .

$$s = ae^{-kt} \sin nt + b$$

$$s = 648.0 \text{ when } t = \frac{\pi}{2n} \text{ radian}$$

$$s = 380.7 \text{ when } t = \frac{3\pi}{2n}$$

$$s = 616.8 \text{ when } t = \frac{5\pi}{2n} \text{ and } \frac{\pi}{n} = 1.3$$

Find the value of k .

33. In another experiment like that of the last example

$$s = 469.3 \text{ when } t = \frac{\pi}{2n}$$

$$s = 538.0 \text{ when } t = \frac{3\pi}{2n}$$

$$s = 477.3 \text{ when } t = \frac{5\pi}{2n}, \frac{\pi}{n} = 1.5$$

Find the value of k .

34. S is the quantity of common salt which will dissolve in 100 parts by weight of water at temperature $t^\circ \text{C}$.

There is a formula connecting S and t of the form

$$\log S = a + b\left(\frac{t}{100}\right) + c\left(\frac{t}{100}\right)^2$$

Find the values of a , b , and c from the following data:—

S	36.13	37.25	38.22
t	25	60	80

55. Identities.—We have said that an equation of the n th degree has only n roots, *i.e.* that it is satisfied by n values of x . If we find that an

equation involving an unknown quantity x in the n th degree and a number of constants, is satisfied by more than n values of x , it can be shown that it is true for all values of x ; it is then spoken of as an **identity**.

The sign \equiv is used to express identity, e.g. the equation

$$(x + 1)(x + 2) = x^2 + 3x + 2$$

is true for all values of x .

The coefficients of each power of x must be separately equal on the two sides of an identity.

EXAMPLE.—Find the value of the product $(x + 2)(x - 3)(x^2 + 5)$.

The result will evidently be of the fourth degree in x .

Let $(x + 2)(x - 3)(x^2 + 5) \equiv Ax^4 + Bx^3 + Cx^2 + Dx + E$, where A, B, C, D, E are numbers which we require to find.

Since this is identically true for all values of x , A must be equal to the coefficient of x^4 on the left-hand side of the equation. $\therefore A = 1$.

This process is known as **equating coefficients of x^4** .

Similarly B is equal to the coefficient of x^3 on the left-hand side of the equation, i.e. $B = 2 - 3 = -1$.

In the same way, by equating coefficients of x^2 and x , and the constant terms, we get

$$C = -1, D = -5, E = -30$$

and the required product is equal to

$$x^4 - x^3 - x^2 - 5x - 30$$

EXAMPLES. —XXXI.

Before reading the next paragraph the student should work the following examples:—

Reduce each of the following to a single fraction in its lowest terms:—

1. $\frac{3}{x-2} - \frac{3}{x+2}$.

2. $\frac{3}{x-3} + \frac{5}{x+3} + \frac{2}{x-2}$.

3. $\frac{1}{x+1} - \frac{3}{x+2} + \frac{4}{x-5}$.

4. $\frac{3}{2x+9} + \frac{5}{3x-1} - \frac{6}{x+7}$.

5. $\frac{3}{x^2+2x+5} + \frac{5}{x-3}$.

6. $\frac{2x+7}{x^2-4x+9} - \frac{3}{x-2}$.

7. $\frac{3}{x-2} + \frac{4}{(x-2)^2} + \frac{2}{x-1}$.

8. $\frac{6x+1}{(x+5)^2} + \frac{3}{x+5} + \frac{4}{x+2}$.

9. $\frac{3x-1}{(x+2)^2} + \frac{5}{x+1}$.

10. $\frac{9}{5(x+2)} - \frac{8}{5(2x-1)}$.

11. $\frac{1}{21(x+2)} + \frac{1}{28(x-5)} - \frac{1}{12(x-1)}$.

56. Resolution into Partial Fractions.—The student already knows how to express the sum of a number of fractions as a single fraction whose denominator is the least common multiple of the denominators of the given fractions, as in the above examples. It is sometimes necessary to carry out the converse operation, i.e. having given a single fraction, to express it as the sum of a number of simpler fractions. This process is spoken of as the resolution of the single fraction into partial fractions. The method will be best understood from a consideration of the following examples.

EXAMPLE (1).—To resolve the fraction $\frac{2x-5}{2x^2+3x-2}$ into partial fractions.

Resolve the denominator into its simplest factors $x+2$ and $2x-1$. We see that $x+2$ and $2x-1$ are possible forms of the denominators of simple fractions of which the given fraction is the sum.

Assume $\frac{2x-5}{(x+2)(2x-1)} = \frac{A}{x+2} + \frac{B}{2x-1}$, where A and B are constants.

Multiply both sides by the L.C.M. of the denominators.

$$2x-5 = A(2x-1) + B(x+2)$$

This is an identity, and is true for all values of x . Assume $x = -2$, and substitute. Then the coefficient of B vanishes, and we have

$$-9 = -5A \quad \therefore A = \frac{9}{5}$$

To find B assume $x = \frac{1}{2}$, and substitute. Then the coefficient of A vanishes, and we have

$$-4 = \frac{5}{2}B \quad \therefore B = -\frac{8}{5}$$

$$\therefore \frac{2x-5}{(x+2)(2x-1)} = \frac{9}{5(x+2)} - \frac{8}{5(2x-1)}$$

Note that this agrees with example 10 above.

EXAMPLE (2).—Resolve the fraction $\frac{1}{(x-1)(x+2)(x-5)}$ into partial fractions.

Assume $\frac{1}{(x-1)(x+2)(x-5)} = \frac{A}{x-1} + \frac{B}{x+2} + \frac{C}{x-5}$

$$\therefore 1 = A(x+2)(x-5) + B(x-5)(x-1) + C(x-1)(x+2)$$

Let $x = 1$; then, substituting

$$1 = -12A + 0 \times B + 0 \times C \quad \therefore A = -\frac{1}{12}$$

Let $x = -2$; then $1 = 21B$ and $B = \frac{1}{21}$

Let $x = 5$; then $1 = 28C$ and $C = \frac{1}{28}$

$$\therefore \frac{1}{(x-1)(x+2)(x-5)} = -\frac{1}{12(x-1)} + \frac{1}{21(x+2)} + \frac{1}{28(x-5)}$$

This agrees with example 11 above.

EXAMPLE (3).—It sometimes happens that the factors of the first degree in the denominator are not all different, one or more factors being squared or cubed, as in the fraction $\frac{1}{(x-1)^2(x+2)(x+5)}$.

In this case a fraction of the form $\frac{A}{x-1}$ as well as a fraction of the form $\frac{B}{(x-1)^2}$ may occur among the partial fractions of which the given fraction is the sum.

Assume $\frac{1}{(x-1)^2(x+2)(x+5)} = \frac{A}{x-1} + \frac{B}{(x-1)^2} + \frac{C}{x+2} + \frac{D}{x+5}$

$$\therefore 1 = A(x-1)(x+2)(x+5) + B(x+2)(x+5) + C(x-1)^2(x+5) + D(x-1)^2(x+2)$$

B, C, and D may be found by substituting suitable values of x as before.

$$\text{If } x = 1 \text{ we get } 1 = -12B \quad \therefore B = -\frac{1}{12}$$

$$\text{If } x = -2 \text{ ,, } 1 = -63C \quad \therefore C = -\frac{1}{63}$$

$$\text{If } x = 5 \text{ ,, } 1 = 112D \quad \therefore D = \frac{1}{112}$$

Since the above equation is an identity, the coefficients of each power of x must be separately equal on both sides of the equation.

∴ equating coefficients of x^2 we get

$$1 = A + C + D = A - \frac{1}{3} + 1\frac{1}{3}$$

$$\therefore A = \frac{1}{3}$$

$$\therefore \frac{1}{(x-1)^2(x+2)(x-5)} = \frac{1015}{1008(x-1)} - \frac{1}{12(x-1)^2} - \frac{1}{63(x+2)} + \frac{1}{112(x-5)}$$

In the same way if $(x-1)^2$ had occurred in the denominator we should have assumed $\frac{A}{x-1} + \frac{B}{(x-1)^2} + \frac{C}{(x-1)^3}$ as the corresponding partial fractions.

EXAMPLE (4).—It may happen that the denominator cannot be completely resolved into real factors of the first degree. Any algebraical expression can be resolved into real factors of the first or second degree.

Resolve $\frac{3x+5}{(x^2+x+1)(x-6)}$ into partial fractions.

$$\text{Assume } \frac{3x+5}{(x^2+x+1)(x-6)} = \frac{A}{x-6} + \frac{Bx+C}{x^2+x+1}$$

Multiplying across we get

$$3x+5 = A(x^2+x+1) + Bx(x-6) + C(x-6)$$

Substitute $x=6$; then $23 = 43A$, $A = \frac{23}{43}$.

Since no real values of x will make the coefficient of A vanish, the constants B and C must be found by equating coefficients of powers of x .

Equating coefficients of x^2 on both sides of the equation, we have

$$0 = A + B = \frac{23}{43} + B \quad \therefore B = -\frac{23}{43}$$

Equating constant terms

$$5 = A - 6C \quad \therefore C = -\frac{5 - \frac{23}{43}}{6} = -\frac{3}{43}$$

$$\therefore \frac{3x+5}{(x^2+x+1)(x-6)} = \frac{23}{43(x-6)} - \frac{23x+32}{43(x^2+x+1)}$$

EXAMPLES.—XXXII.

Resolve into partial fractions—

1. $\frac{4}{x^2-4}$

2. $\frac{2}{x^2+8x+15}$

3. $\frac{3x+8}{x^2+7x+6}$

4. $\frac{2x+5}{x^2+5x+6}$

5. $\frac{x}{x^2-x-20}$

6. $\frac{5x+7}{(x-1)(x+2)(x+3)}$

7. $\frac{4x+23}{(2x+1)(x-3)(x+2)}$

8. $\frac{3x^2+4x-2}{(x+1)^2(x-2)}$

9. $\frac{x^2-x+2}{(x-2)(x+3)(x+1)}$

10. $\frac{2x-1}{(x-4)(2x+1)(x+3)}$

11. $\frac{3x+2}{x^3+2x^2-x-2}$

12. $\frac{1}{(x-2)(x+3)(x-4)(x+1)}$

13. $\frac{x-2}{(x-3)(x+3)(x-4)}$

14. $\frac{x^2+2x+1}{(x+4)(x+3)(x-1)}$

15. $\frac{1}{(x-3)(x+4)(2x+1)}$

16. $\frac{7x^3-24x^2+6x-25}{(x-1)^2(x-4)(x+3)}$

17. $\frac{7x^2+13x+9}{(2x-1)(x^2+3x+4)}$

18. $\frac{8x+11}{(x-2)(x^2+x+3)}$

19. $\frac{3x+1}{(x^2+x+2)(x-2)^2}$

20. $\frac{1}{a^2+(a+b)\theta+ab}$

CHAPTER VII

PLOTTING OF FUNCTIONS

unction.—Consider the following table, which gives the value of the coefficient of friction for certain bearings at different speeds.

Speed v , ft. per min.	1	3	5	7	10	15	20
Coefficient of friction μ	0.15	0.122	0.104	0.092	0.079	0.066	0.058

We have here two variable quantities, μ and v , connected in such a way that whenever v is fixed the value of μ is also fixed. If we choose any value

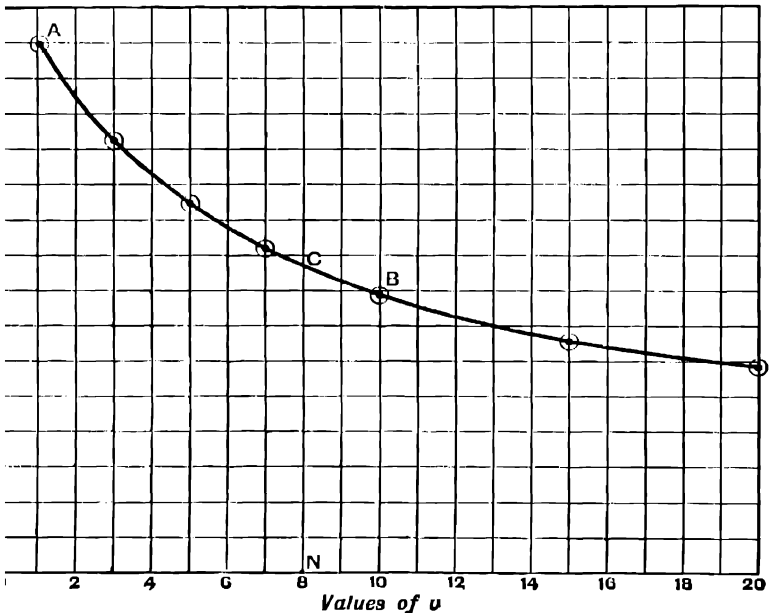

FIG. 40.

whether given in the table or not, there must be some definite value of μ corresponding to it.

We express this relation by saying that μ is a function of v . Plot a series of points on squared paper having values of v for their abscissæ and values of μ for their ordinates (see § 12). *E.g.* in Fig. 40 the co-ordinates of A are 1 and 0.15, the co-ordinates of B are 10 and 0.079.

Draw a curve through the points thus obtained. Then, if we choose any value of v , the probable corresponding value of μ is given by the ordinate of the curve which corresponds to the chosen value of the abscissa v ; *e.g.* when we find that the ordinate CN, corresponding to the abscissa ON, which is equal to 8, is equal to 0.087, $\therefore \mu$ is 0.087 when the speed is 8 feet per second. We say that the curve AB represents μ as a function of v . All the functions with which we shall have to deal can be represented in this way by various curves, and, at the present stage, the student should consider the statement that y is a function of x , as meaning that values of y can be determined by the ordinates of a curve for which corresponding values of x are the abscissæ.

A function of x may be given in the form of an expression in terms of x . $x^2 + 2x^2 + 1$, $\sin(2x + 1)$, $\tan(x + 1)$ are functions of x , for, when any value of x is chosen, the value of each of these expressions is fixed, and from a number of values of x we can calculate a number of values of each of the functions, and so plot a curve giving the value of the function for any value of x between two chosen values.

It is not, however, necessary that we should know any formula to calculate the values of x . We may have merely a list of observed values of y and x , as in the case of μ and v above, but so long as a regular curve can be drawn through the connection between y and x we speak of y as a function of x .

When we speak of y as the dependent and x as the independent variable, and the connection between y and x is given by an equation we call this the equation to the curve representing y as a function of x .

For instance, if it is given that $y = 3x^3 - 2x^2 + 1$, we can calculate a series of values of y corresponding to selected values of x , and thus plot a curve representing this equation.

Interpolation.--When the values of a function of x are given by tables for equal intervals in the value of the independent variable x , we often require to find values of the function between the values given in the tables. The table of sines at the end of this book gives the values of $\sin x$ at intervals of one degree in the value of x ; we often require to use this table to find the sines of angles which do not contain an exact number of degrees. This process is called interpolation.

If the difference between two successive values of x is small, we may use a large scale points representing the function for the two values of x in the tables nearest on each side to the value of x for which the value of y is required. We may usually assume, if the values given in the tables are sufficiently close together, that the portion of the curve representing the function between these two values is a straight line. Joining the two points we may obtain from the straight line the required intermediate value of y . This is equivalent to taking a small portion from the curve representing the function, and magnifying it. In the case of all functions with which we shall have to deal, the portion of the curve taken will be approximately straight if sufficiently magnified.

TE.--In the worked examples of this and the following chapters the measurements are taken from figures drawn on squared paper on a much larger scale than can be used in the figures of this book. Owing to difficulties of reproduction, the small squares of the squared paper have not all been shown. The student should in all cases draw the figure for himself on a large scale on paper ruled into squares by thick lines at intervals of 1 in., and fine lines at intervals of $\frac{1}{10}$ in.

For this purpose the numerical data have been given to a higher degree of accuracy than can be shown in the figures.

EXAMPLE (1).—Find the values of $\sin 25^{\circ}45'$, $\sin 42^{\circ}36'$, $\sin 65^{\circ}42'$, $\sin 81^{\circ}83'$.

These values have been selected so as to test the accuracy of the graphic method of interpolation at different places in the table of sines.

From the tables we find $\sin 25^{\circ} = 0.4226$, $\sin 26^{\circ} = 0.4334$.

Plotting these values at **A** and **B**, and joining **AB**, we find that the ordinate to the line **AB** at the point corresponding to $25^{\circ}45'$ is 0.4297 .

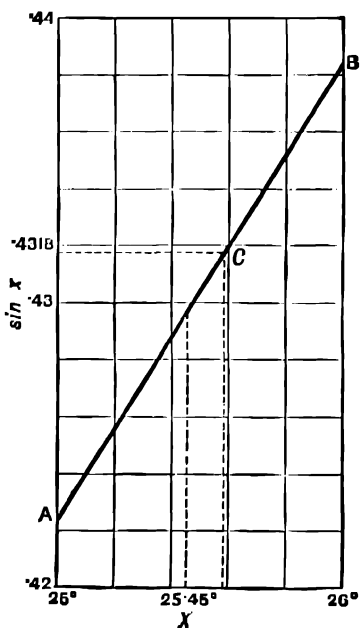

FIG. 41.

The value given in more complete tables is 0.42972 .

In the same way we obtain the following results, which the student should verify by plotting the points for himself:—

Angle.	Sine by plotting.	Sine from tables.
$42^{\circ}36'$	0.6737	0.67379
$65^{\circ}42'$	0.9092	0.90938
$81^{\circ}83'$	0.9899	0.98985

Thus the error is in none of these cases greater than 0.0002 , or about 0.02 per cent.

Since the same table is used to find cosines, it follows that we may rely upon it to the same degree of accuracy in interpolating values of $\cos x$.

EXAMPLE (2).—It is found that the sine of a certain angle is 0.4318; to find the angle.

The value 0.4318 is not given exactly in the tables, but lies between $\sin 25^\circ = 0.4226$ and $\sin 26^\circ = 0.4384$.

Plotting these values as in the last example, we find that the point **C** in **AB** has the ordinate 0.4318. The abscissa corresponding to this is 25.58°

$$\therefore 0.4318 = \sin 25.58^\circ.$$

EXAMPLES.—XXXIII.

Find the values of the following :—

1. $\sin 27.45^\circ$; $\sin 27.8^\circ$; $\sin^{-1} 0.4612$; $\sin^{-1} 0.4570$.
2. $\sin 71.5^\circ$; $\sin 71.32^\circ$; $\sin^{-1} 0.9500$; $\sin^{-1} 0.9482$.
3. $\cos 57.6^\circ$; $\cos 57.9^\circ$; $\cos^{-1} 0.5336$; $\cos^{-1} 0.5417$.
4. $\tan 33.6^\circ$; $\tan 33.25^\circ$; $\tan^{-1} 0.6523$; $\tan^{-1} 0.6602$.
5. $\sin 0.45^\circ$; $\sin 1.45^\circ$; $\sin 2.45^\circ$.
6. Express 34.25° and 34.7° in radians, and 0.6000 radian in degrees, using the tables at the end of the book, and a graphic method of interpolation.
7. Express 1.195 radians and 2.3998 radians in degrees.
8. Find the value of $\log 12.8873$, having given $\log 12.88 = 1.109916$, $\log 12.89 = 1.110253$.
9. Find $\log 10.7352$, given $\log 10.73 = 1.030600$ and $\log 10.74 = 1.031004$.
10. Find the values of $\cos 135.61^\circ$ and $\cos^{-1}(-0.7167)$.

59. When the interval between the given values is not comparatively small, and in any case when we are not sure how far it is accurate to take the portion of the curve between the two given values as a straight line, we may plot three or four successive values from the tables, and draw the curve through these.

EXAMPLE.—The following values are taken from a table of cube roots :—

x	6	7	8	9
$\sqrt[3]{x}$	1.8171	1.9129	2.00	2.0801

Find the values of $\sqrt[3]{6.25}$ and $\sqrt[3]{8.13}$.

On plotting the given values we get the curve **AB** (Fig. 42). **A** and **B** are the points whose abscissæ are 6.25 and 8.13.

Reading off the ordinates at **A** and **B**, we get

$$\sqrt[3]{6.25} = 1.841; \quad \sqrt[3]{8.13} = 2.010$$

The correct values to 5 significant figures are

$$\sqrt[3]{6.25} = 1.8420; \quad \sqrt[3]{8.13} = 2.0108$$

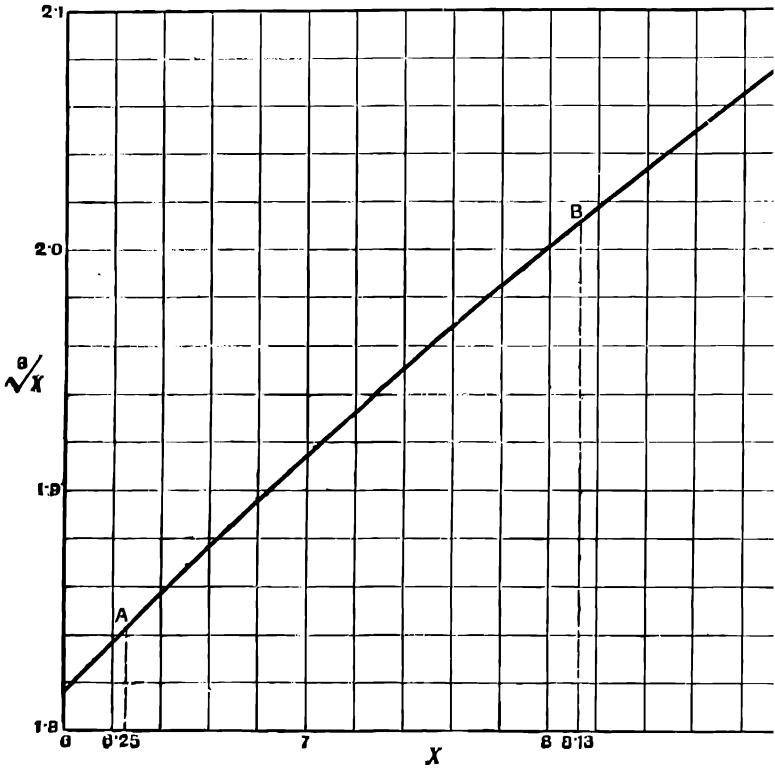

FIG. 42.

EXAMPLES.—XXXIV.

1. From the data given in the following table, find the values of 78.83^2 and 79.31^2 :—

x	78	79	80
x^2	6084	6241	6400

2. From the following data find the values of $\frac{1}{404.64}$ and $\frac{1}{406.15}$:—

x	404	405	406	407
$\frac{1}{x}$	0.002475248	0.002469136	0.002463054	0.002457002

3. From the following data find the values of $(2.253)^2$ and $(3.861)^2$:—

x	2	3	4
x^2	4	9	16

4. Given

x	10	11	12
$\frac{1}{x}$	0.1	0.090909	0.083333

Find the values of $\frac{1}{1.013}$ and $\frac{1}{1.127}$.

5. Given

x	4	5	6	7
x^3	64	125	216	343

Find the values of 4.361^3 and 5.732^3 .

6. Given

x	6	7	8	9
$\sqrt[3]{x}$	1.8171206	1.9129312	2.0	2.0800837

Find the values of $\sqrt[3]{6.25}$ and $\sqrt[3]{8.13}$.

7. Given

x	6	7	8	9
\sqrt{x}	2.4495	2.6457	2.8284	3.0

Find the values of $\sqrt{7.5}$ and $\sqrt{8.25}$.

80. Graphic methods of interpolation may be used to solve problems like the following :—

EXAMPLE.—*The proprietor of a certain patented article finds that the number which he can sell at various prices is given by the following table :—*

Selling price in pence	6	12	18	24	30
Number sold	38,000	35,000	20,000	8400	5600

Each article costs him sixpence to make.

Plot a curve to show the probable number sold at any price from 6d. to 2s. 6d., and find the number which he will probably sell if he fixes the price at 1s. 4d.

Also plot a curve to show his total profit at any price, and find at what price it will be most profitable for him to sell the article.

On plotting the given values we get the curve **A** (Fig. 43), showing the number sold at any price from 6d. to 2s. 6d. The number sold at 1s. 4d. is given by the ordinate at **A**, where the abscissa is 16. The ordinate at **A**, and therefore the probable number sold at 1s. 4d., is 26,000.

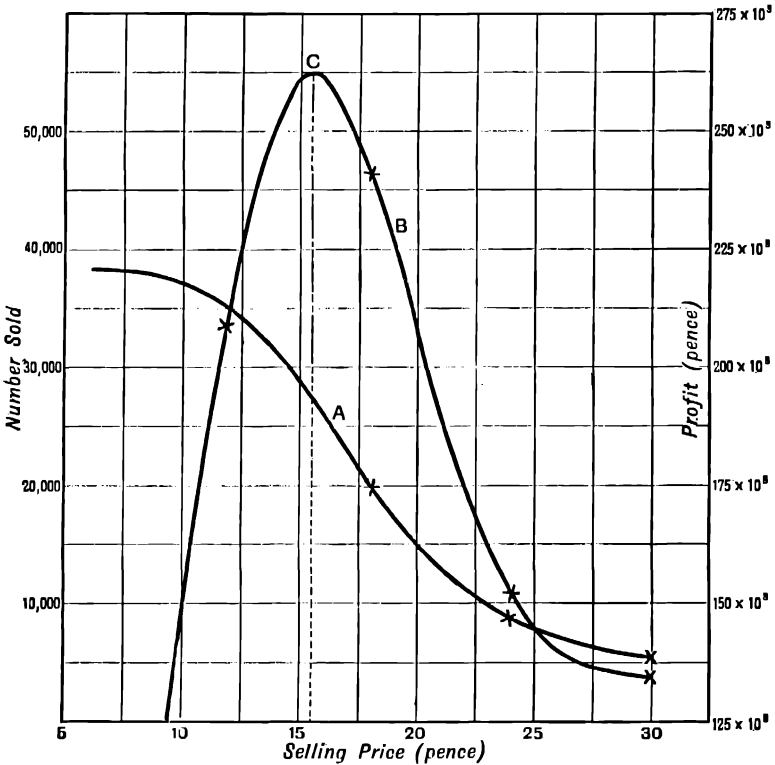

FIG. 43.

The total profit at any price is found by multiplying the number sold at that price by the excess of the price over 6d.

By plotting the total profits, first at the prices given in the table, and then at those points where it is seen that the curvature of the resulting curve will be greatest, we obtain the curve **CB**, showing the total profit as a function of the selling price. The

ordinate is greatest at **C**, and therefore it will be most profitable to sell the article at 1s. 4d., the total profit at that price being about £1080.

EXAMPLE (2).—It is required to devise a graduated scale of income tax, so that incomes of £160 shall pay nothing, and incomes of £700 shall pay 1s. 2d. in the pound. All other incomes are to be taxed according to a linear law satisfied by the two given cases. What would be the tax on incomes of £300, £500, and £1000?

We are given that the curve connecting income and rate of tax is a straight line.

Taking values of total income as abscissæ, and rates of income tax as ordinates, and plotting the two given cases, we get the points **A** and **B** (Fig. 44).

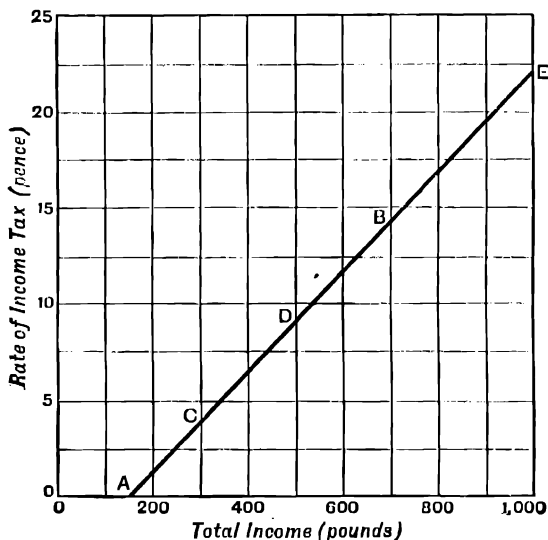

FIG. 44.

The straight line through these points gives the proper rate of tax for other incomes.

From the figure we find the following values as given by the ordinates at the points **C**, **D**, and **E**.

Income.	Rate of Income tax.	
£	s.	d.
300	0	3½
500	0	8½
1000	1	9½

EXAMPLES.—XXXV.

1. The following table gives the amount which £100, accumulating at 2½ per cent. compound interest, will reach in the times specified :—

Time in years	10	20	30	40	50
Amount of £100	128·01	163·86	209·76	268·51	343·71

Plot a curve to show the amount of £100 at $2\frac{1}{2}$ per cent. for any number of years from 0 to 50.

From your curve find the amount of £100 in 7 and 24 years respectively.

2. S is the distance in yards at which a train can be stopped on the level when going at a speed of V miles per hour.

V	30	40	55	60
S	100	180	340	400

What is the distance for speeds of 35 and 50 miles per hour?

3. A steam electric generator on three long trials is found to use the following amounts of steam per hour for the following amounts of power:—

Pounds of steam per hour	4020	6650	10,800
I.H.P.	210	480	706
Kilowatts produced	114	290	435

Find the I.H.P. and the weight of steam used per hour when 330 kilowatts are produced.

(Board of Education Examination in Steam, 1901.)

4. E is the modulus of elasticity of wrought iron, in grammes per square millimetre, at temperature t° C.

t	0	20	100	200	300
E	21,483	21,441	21,212	20,458	19,175

What are the probable values of E at temperatures of 50° , 150° , and 250° respectively?

5. T is the tensile strength, in tons per square inch, of steel containing x per cent. of carbon.

x	0.14	0.46	0.57	0.66	0.78	0.80	0.87	0.96
T	28.1	33.8	35.6	40	41.1	45.9	46.7	52.7

Plot a curve to show as accurately as the data will allow the probable tensile strength of steel containing any percentage of carbon from 0.1 to 1 per cent.

What strength would you expect to find in steels containing 0.40 per cent., and 0.70 per cent., of carbon respectively?

6. S is the sag in the middle of a 120-foot span of trolley wire of copper, 0.4 in. in diameter, and T the tension at temperature t° F.

t° F	0	105	152	180
S inches	3	6	9	12
T lbs.	3,600	1800	1200	900

Find the sag and the tension at temperature 70° F.

7. p is the pressure in lbs. per square foot of saturated steam at temperature θ° C. Make a table to show as accurately as you can from the given data the value of p for every exact number of degrees from 105° to 125° .

θ	105	110	115	120	125
p	2524	2994	3534	4152	4854

What is the pressure at temperature 108.4° ? At what temperature is the pressure 4320 lbs.?

8. v cu. ft. is the volume of 1 lb. of saturated steam at pressure p lbs. per square inch.

p	60	65	70	75	80	85
v	7.03	6.52	6.09	5.70	5.37	5.07

What are the volumes at pressures 69.21, 79.03, and 89.86?

9. H is the horizontal intensity of the earth's magnetic field in latitude 50° N. at the following longitudes:—

Longitude	10° W.	0	10° E.	20° E.	30° E.
H	181	188	195	201	217

What is the probable value of H in longitude 3° W., and 15° E.

10. The following table gives the time of sunset at the following dates:—

Jan. 1.	Jan. 10.	Jan. 16.	Jan. 30.	Feb. 5.
3.59	4.9	4.18	4.42	4.53

Plot a curve to show the time of sunset on any day in January. Find the times of sunset on January 4th and January 20th.

11. The following table gives the expectation of life of males at all ages from 0 to 100:—

Age	0	5	10	15	20	25	30	35	40	45	50
Expectation of life	41·35	50·87	47·60	43·41	39·40	35·68	32·10	28·64	25·30	22·07	18·93

Age	55	60	65	70	75	80	85	90	95	100
Expectation of life	15·95	13·14	10·55	8·27	6·34	4·79	3·56	2·66	2·01	1·61

What is the probable expectation of life at the following ages: 7 years, 14 years, 16 years, and 43 years?

12. N is the number of males out of every million born surviving at the following ages:—

Age.	N.
0	1,000,000
1	836,405
5	723,716
10	689,857
15	672,776
20	651,903
25	624,221
30	595,089
35	564,441
40	531,657

What is the probable number surviving at 17 years of age?

Out of 1000 living at the age of 17 years, how many will probably survive at 33 years?

13. An examiner has to give marks to papers; the highest number is 185, the lowest 42. He desires to change all his marks according to a linear law, converting the highest number of marks into 250, and the lowest into 100; show how he may do this, and state the converted marks for papers already marked 60, 100, and 150.

(Board of Education Examination, 1902.)

14. $\mathcal{L}r$ is the total return in money obtained from a certain farm when $\mathcal{L}C$ per annum of capital and labour are invested in it.

C	100	150	200	250	300	350
r	60	67	95	105	108	109

Plot a curve showing the probable return for any investment from $\mathcal{L}100$ to $\mathcal{L}350$. What is the probable return for an investment of $\mathcal{L}225$?

15. Green peas are brought into the market of a county town. Early in the season 100 lbs. per day are brought in and sold at 1s. per lb. Late in the season, when peas are plentiful, 10,000 lbs. are brought in and sold at $1\frac{1}{2}d$. The intermediate amounts and prices are given in the following table:—

Quantity brought into the market . . .	100	500	1000	2000	5000	10,000
Price per lb. . . .	12	6	4	3	2	$1\frac{1}{2}$
Cost of growing and marketing per lb. .	4	3·2	2	2	$1\frac{1}{2}$	$1\frac{1}{2}$

Plot curves to show the price and cost per pound for any supply in the market from 100 lbs. to 10,000 lbs.

Also plot a curve to show the total profit on the whole amount sold for various supplies. What quantity must the producers bring into the market so as to make the total profit on the whole supply the greatest possible?

To construct the last curve use your two previous curves; do not construct it from the given numbers alone.

16. In the wholesale wheat market, on a certain date, A is the amount which holders of wheat will be willing to sell at a price p . B is the amount which buyers will take at price p .

p	31s.	30s. 6d.	30s.	29s. 6d.	29s.	
A	292,000	275,000	250,000	210,000	150,000	bushels
B	150,000	183,000	225,000	280,000	350,000	bushels

On the same paper plot (1) a curve to show the price required to call forth any supply A from 150,000 to 300,000 bushels; (2) a curve to show the price required to cause any demand B from 150,000 to 350,000 bushels.

The market price tends to settle at that value for which the amounts supplied and the amounts demanded by buyers are equal. What is the probable market price in this case?

61. The Straight Line.—Let us plot the curve such that the co-ordinates x and y of any point on it satisfy the equation $y = 2x + 3$.

By calculation we find the following corresponding values of y and x .

x	0	0·5	1	1·5
y	3	4	5	6

On plotting these points we get **PB**, Fig. 45.

This is a straight line, and we shall find that if we take any other values

of x and calculate y the corresponding points will lie on the same straight line, e.g. when $x = 0.75$, $y = 4.5$, and the point $(0.75, 4.5)$ is found to lie on the straight line **PB**.

It can be proved that any equation of the first degree, such as $y = mx + c$, where m and c have any constant numerical values, represents a straight line. In the above case $m = 2$, $c = 3$. (Ex. XXXVII., 9.)

A straight line is fixed if we know the position of any two points upon it, and we can find the equation of the straight line from the co-ordinates of any two points upon it.

EXAMPLE.—Find the equation of the straight line joining the points $(1, 3)$, and $(1.5, 2)$. These are the points **Q** and **R** in Fig. 45.

Let the equation be $y = mx + c$.

Then, since the point $(1, 3)$ is on the line, the values $x = 1$ and $y = 3$ must satisfy the equation ;

$$\therefore 3 = m + c$$

Similarly, $x = 1.5$ and $y = 2$ must satisfy the equation ;

$$\therefore 2 = 1.5m + c$$

We have now a pair of simultaneous equations to find m and c .

Solving these we get $m = -2$, $c = 5$; therefore the equation to the straight line **QR** is $y = -2x + 5$.

To verify this we may take any other value of x , calculate y from the equation, and find whether the point obtained lies on the straight line; e.g. when $x = 2$, $y = -4 + 5 = 1$, and we find that the point **S**, whose co-ordinates are $(2, 1)$, lies on the straight line **QR**.

EXAMPLES.—XXXVI.

Draw the straight lines represented by the following equations. Calculate the values of y corresponding to two values of x in each case; draw the straight line through the two points thus obtained; calculate from the equation the value of y for a third point, and verify that this point lies on the same straight line.

1. $y = 2x + 1$.

4. $y = -2x + 2$.

7. $y = 1.4x + 0.3$.

2. $y = 4x + 2$.

5. $y = -3x - 0.5$.

8. $y = -1.4x + 0.3$.

3. $y = x - 1$.

6. $y = 4x - 4$.

Draw the straight lines through the following pairs of points, and find their equations.

9. $(121, 59)$ and $(128, 62)$.

11. $(-2, 13)$ and $(3, -12)$.

13. $(2, 1)$ and $(-3, 4)$.

15. $(-5, 4)$ and $(6, 3)$.

17. $(11, -1.2)$ and $(17, -0.6)$.

10. $(1, -5)$ and $(4, 1)$.

12. $(2, -3)$ and $(5, -7)$.

14. $(-2, 3)$ and $(3, -5)$.

16. $(1, 5)$ and $(-5, 23)$.

62. To find the Meaning of m and c in the Equation $y = mx + c$.—Plot the following straight lines :—

(1) $y = 10x + 3$; (2) $y = 2x + 3$; (3) $y = 0 \times x + 3$;

(4) $y = -3x + 3$; (5) $y = -10x + 3$

These equations are all of the form $y = mx + c$, c is equal to 3 in all of them, but the values of m are different.

We obtain the straight lines **PA**, **PB**, **PC**, **PD**, **PE**.

These straight lines all start from the same point P, where $y = 3$ on the axis of y , but make different angles with the axis of x . We notice that when m is large the line slopes steeply upwards. As m gets smaller the line becomes less steep, and when m is zero the slope of the line is zero.

When m is negative the line slopes downwards as x increases.

If we take any two points P and A on a straight line, and draw lines PN and AN parallel to the axes of x and y respectively, then the value of the fraction $\frac{AN}{PN}$ is called the slope of the line PA, AN and PN being each measured on the scale proper to the axis to which it is parallel.

When the same scale is taken on the two axes $\frac{AN}{PN}$ is the tangent of the angle which the line PA makes with the axis of x . We may note that when x increases by the amount PN, y increases by the amount AN, and therefore the slope of the straight line measures the increase of y per unit increase of x , or the rate of increase of y with respect to x .

We find, by measurement,

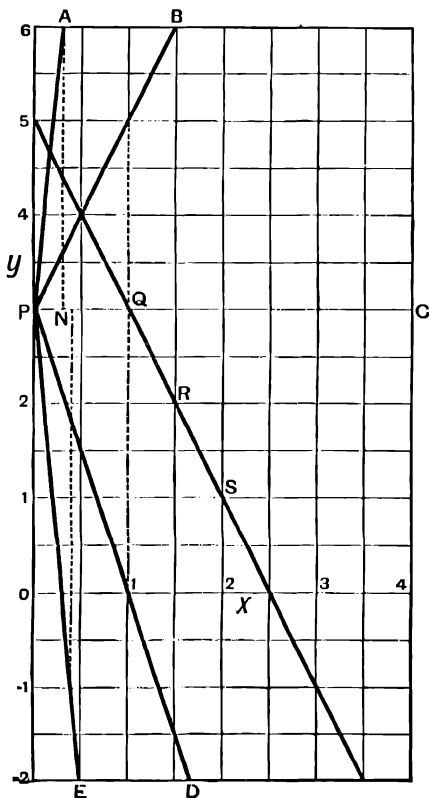

FIG. 45.

$$\text{Slope of PA} = \frac{3}{0.3} = 10 = m \text{ in equation (1)}$$

$$\text{'' PB} = \frac{2}{1} = 2 = m \text{ '' (2)}$$

$$\text{'' PC} = 0 = m \text{ '' (3)}$$

$$\text{'' PD} = \frac{-3}{1} = -3 = m \text{ '' (4)}$$

$$\text{'' PE} = \frac{-4}{0.4} = -10 = m \text{ '' (5)}$$

Similarly, it will be found in any case that in the equation $y = mx + c$, m measures the slope of the straight line represented by the equation.

To find the meaning of c we note that if we put $x = 0$ in the equation $y = mx + c$, we get $y = c$, and therefore c is the value of y when $x = 0$; i.e. c is the length cut off on the axis of y by the straight line $y = mx + c$; e.g. in Fig. 45 all the straight lines cut off the length 3 on the axis of y , and $c = 3$ in all the equations.

EXAMPLES.—XXXVII.

1. Plot the straight lines $y = 2x + 6$; $y = 2x + 1$; $y = 2x + 0$; $y = 2x - 2$; $y = 2x - 6$; and show from your figure that in each case c is the intercept on the axis of y . Since these lines all have the same value of m , we should expect them all to have the same slope, *i.e.* to be parallel. Verify this from your figure.

2. Draw the following straight lines: $y = x$, $y = 2x - 5$, $y = 3x - 4$, $y = -3x + 2$, and $y = 8x - 3$, on the same sheet of paper, and verify that in each case m is the slope of the line, and c is the intercept on the axis of y .

3. Verify by measurement that the slope of each of the straight lines in Examples XXXVI., 1 to 8, is equal to the value of m in its equation.

4. If V is the volume at temperature $\theta^\circ \text{C}$. of a portion of gas which occupies 100 cc. at 0°C ., it is known that $V = 100 + 0.367\theta$.

Plot a curve to show the value of V at any temperature from 0°C . to 100°C . Measure the slope of the resulting straight line.

5. The length l of a brass wire under a tension of W lbs. is $l = 10 + \frac{W}{11,500}$.

Plot a curve to show the relation between l and W from $W = 0$ to $W = 70$ lbs.

Since this equation is of the first degree the resulting curve is a straight line; measure its slope, and show that the slope is equal to the value of m in the equation.

6. R is the electrical resistance of a copper wire of 1 mm. diameter, and 1 metre long, at temperature $\theta^\circ \text{C}$.

It is found that $R = 0.0203(1 + 0.0041\theta)$.

Plot a curve to show the value of R at any temperature between 0°C . and 100°C .

7. For nickel of the same dimensions the corresponding formula is

$$R = 0.1568(1 + 0.0062\theta)$$

Plot a curve to show the value of R at any temperature between 0°C . and 100°C .

8. The specific heat of mercury at temperature t is $C_t = 0.03327 - 0.0592t$.

Plot a curve to show the specific heat at any temperature from 0°C . to 50°C .

9. A , B , and C are any three points whose co-ordinates satisfy the equation $y = mx + c$. Show that the straight lines AB and AC have the same slope. Note that it follows that all points whose co-ordinates satisfy the equation $y = mx + c$ lie on the same straight line.

63. In plotting functions the following order is usually the best:—

(1) Calculate from the equation the values of y for the two extreme values of x between which the curve is to be drawn, and for any value of x such as 0, 1, etc., for which the calculation is easy.

(2) Form an estimate of the greatest and least values of y that will occur; note especially whether any negative values of y occur.

(3) Choose the scales for the two axes so that the figure will be extended over the paper as much as possible. The scales need not, of course, begin at zero.

(4) After plotting the points found, calculate intermediate values, taking these nearest together where the curvature is greatest.

64. Curves represented by the Equation $y = ax^n$.—We shall take examples in which a and n have different values.

EXAMPLE (1).—Plot the curve whose ordinate and abscissa are connected by the equation $y = x^3$ from $x = -4$ to $x = +4$.

Here $a = 1$, $n = 3$.

By calculation we get the following values:—

x	-4	4	0	1	-1	2	-2	3	-3	± 0.5	± 1.5	± 2.5	± 3.5
x^3	-64	64	0	1	-1	8	-8	27	-27	± 0.125	± 3.375	± 15.6	± 42.9

Plotting these values we get the curve in Fig. 46.

The true shape of a curve represented by an algebraical equation is only obtained when the same scale is taken on both axes, but for practical purposes it is usually sufficient to have a curve, from which the values of y can be read off for any value of x .

To do this it is not necessary to use the same scale for both axes, and we choose the scales independently, as in Fig. 46, to suit the space at our disposal. In curves of the class $y = ax^n$, this has the same effect as altering the constant a , and accordingly we shall usually take a as unity.

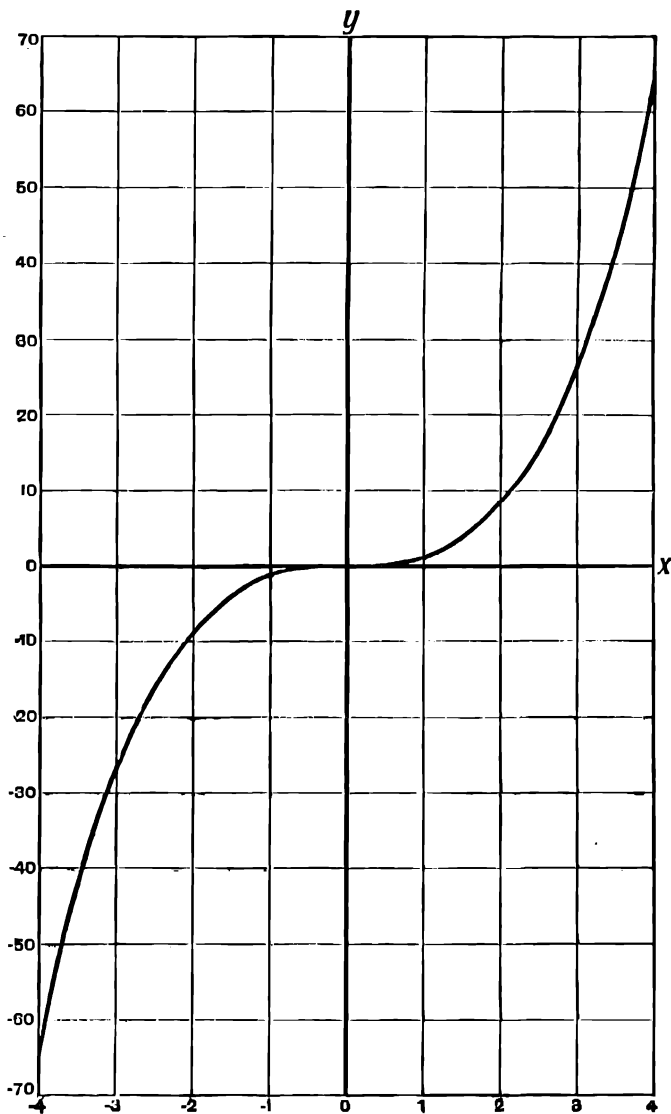

FIG. 46.

The points for which the co-ordinates were actually calculated should be shown by small circles or crosses.

EXAMPLE (2).—Plot the curve $y = x^{2.1}$ between $x = 0$ and $x = 4$.

Here $a = 1$, $n = 2.1$.

Taking logs of both sides of the equation, we get

$$\log y = 2.1 \log x$$

We arrange the calculation as follows :—

x .	$\log x$.	$\log y = 2.1 \log x$.	y .
0			0.00
1			1.00
4	0.6021	1.264	18.37
2	0.3010	0.632	4.28
3	0.4771	1.0019	10.04
1.5	0.1761	0.370	2.34
0.5	1.6990	1.368	0.233

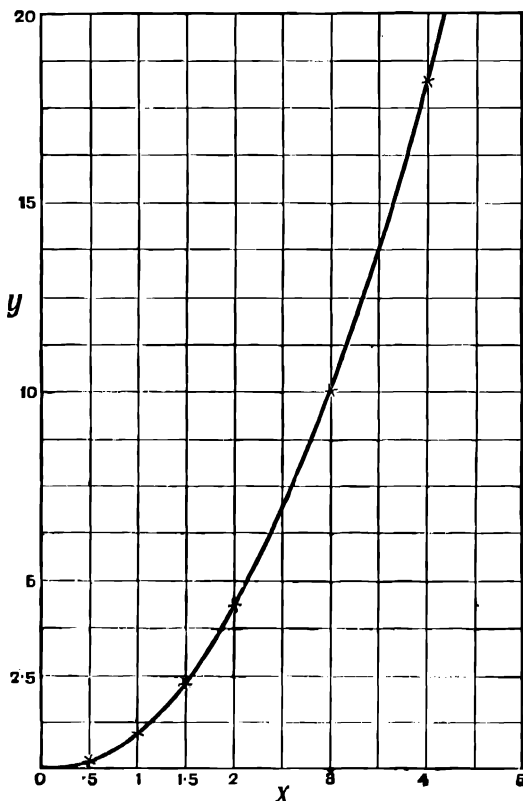

FIG. 47.

Plotting these values we get the curve in Fig. 47. A 10-inch slide rule will usually be found sufficiently accurate for all calculations needed for plotting curves, unless the scale is very large.

EXAMPLE (3).—Plot the curve $y = 2x^{-2}$ from $x = 0.5$ to $x = 4$. We have by calculation

x .	x^2 .	$\frac{2}{x^2} = 2x^{-2} = y$.
0	0	∞
4	16	$\frac{1}{8} = 0.125$
1	1	2.00
2	4	0.50
3	9	0.22
1.5	$\frac{9}{4}$	$\frac{8}{9} = 0.89$
0.5	0.25	8.00
0.7	0.49	4.09
1.2	1.44	1.39
0.6	0.36	5.55

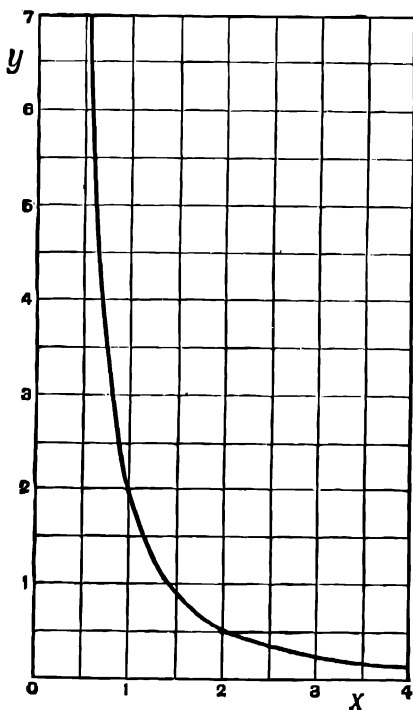

FIG. 48.

Any curve of the class $y = ax^n$ in which n is negative, slopes downwards from infinity as x increases from the value 0.

EXAMPLE (4).—Plot the curves $y = x^{\frac{3}{2}}$ and $y = x^{\frac{2}{3}}$ on the same sheet of paper from $x = 0$ to $x = 5$.

If $y = x^{\frac{3}{2}}$ we have, taking logs, $\log y = \frac{3}{2} \log x$.

x .	$\log x$.	$\frac{3}{2} \log x = \log y$.	y .
1	—	—	1.00
0	—	—	0.00
5	0.699	0.262	1.83
2	0.3010	0.113	1.30
3	0.4771	0.174	1.49
4	0.6021	0.226	1.68
0.5	1.699	1.887	0.77
0.3	1.477	1.804	0.64
0.2	1.301	1.738	0.55
0.1	1.0	1.625	0.42

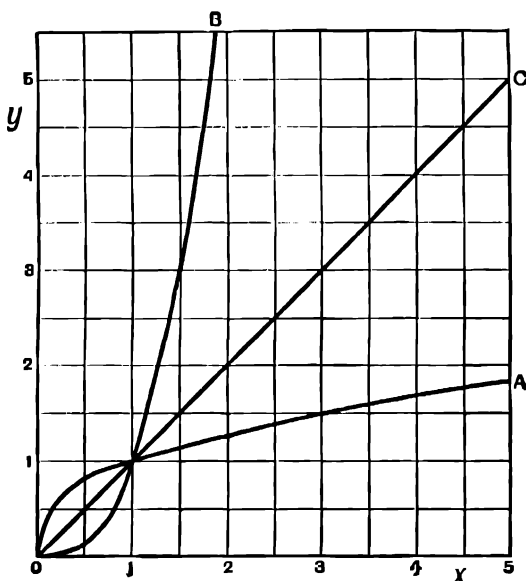

FIG. 49.

Plotting these numbers we get the curve OA. The equation $y = x^{\frac{3}{2}}$ may be written $x = y^{\frac{2}{3}}$, and thus the curve $y = x^{\frac{2}{3}}$ may be obtained from the curve $y = x^{\frac{3}{2}}$ by exchanging the values of x and y for every point on it. We thus get the curve OB.

If we draw a straight line OC through the origin and the point (1, 1), the two curves are symmetrical about the line OC. Any two curves, $y = x^n$ and $y = x^{\frac{1}{n}}$, are symmetrical about the line OC.

EXAMPLES.—XXXVIII.

Plot the following curves:—

1. $y = x^2$ from $x = -4$ to $x = +4$.
2. $y = 0.1x^4$ from $x = -4$ to $x = +4$.
3. $y = 0.1x^3$ from $x = -4$ to $x = +4$.
4. $y = 5x^{-3}$ from $x = -2$ to $x = -0.5$, and from $x = +0.5$ to $x = 2$.
5. $y = 2x^{-4}$ from $x = -2$ to $x = -0.5$, and from $x = +0.5$ to $x = 2$.
6. $y = x^{-1}$ from $x = 0.1$ to $x = 10$.
7. $y = x^2$, and $y = x^{\frac{1}{2}}$, from $x = 0$ to $x = 1.2$ on the same sheet of paper.
8. $y = x^{\frac{4}{3}}$, and $y = x^{\frac{3}{2}}$, from $x = 0$ to $x = 2$.
9. $y = x^{10}$, and $y = x^{\frac{1}{10}}$, from $x = 0$ to $x = 1.05$.
10. $y = 2x^{-1.37}$ from $x = 0.1$ to $x = 10$.
11. $y = 450x^{-1.41}$ from $x = 1$ to $x = 10$.
12. $y = x^2 + 2x - 3$ from $x = -4$ to $x = +4$.
13. $y = x^{3.1} - 2x^{2.0}$ from $x = 3$ to $x = 5$.
14. Draw a figure showing approximately the shape of the curve $y = x^n$, when x has the values 10, 2, 1, $\frac{1}{2}$, $\frac{1}{10}$, 0, $-\frac{1}{10}$, $-\frac{1}{2}$, -1, -2, -10, taking the same scale for x and y . Show all the curves together in the same figure, estimating two or three values of y for each curve.
15. Plot the curve $y = x^2$ on a large scale from $x = 0$ to $x = 3.2$. By means of your curve construct a table giving the square roots of the whole numbers from 1 to 10. Also find the square roots by the arithmetical method, and compare.
16. Plot the curve $y = x^3$ on a large scale from $x = 0$ to $x = 2.2$. Construct a table giving the cube roots of the whole numbers from 1 to 10. Also find the cube roots by logarithms and compare.

65. We shall now give some examples of practical applications of the plotting of curves of the class $y = ax^n$ and related curves.

EXAMPLE (1).—A uniform beam of length l , fixed at one end, supports a weight W at the other. The deflection y at a distance x from the fixed end is given by the formula $y = \frac{W}{EI} (\frac{1}{2}lx^2 - \frac{1}{6}x^3)$. E and I are constants depending on the material and shape of the beam.

Construct a curve to show the deflection at any point of a beam, 10 ft. long, which is deflected 1 ft. at the free end.

Here $l = 10$, and, to find the constant $\frac{W}{EI}$, we have, when $x = 10$, $y = 1$

$$\therefore \text{substituting } 1 = \frac{W}{EI} \cdot \frac{1000}{3}$$

$$\frac{W}{EI} = 0.003$$

We have to plot the curve $y = 0.003(5x^2 - \frac{1}{6}x^3)$.

This should be done on a large scale. The calculation should be set down as follows:—

x .	$5x^2$.	$\frac{x^3}{6}$	$5x^2 - \frac{x^3}{6}$	y .
0	—	—	—	0.0
10	—	—	—	1.0
1	5	0.16	4.83	0.014
3	45	4.5	41.5	0.124
5	125	20.8	104.2	0.312
7	245	57.0	188.0	0.564
8	320	85.0	235.0	0.705
9	405	121.0	284.0	0.852

The shape of the beam is shown in Fig. 50.

If we require the curve to show the deflection at any point, and not the actual shape of the beam, we can plot the deflection y on a larger scale than the length x .

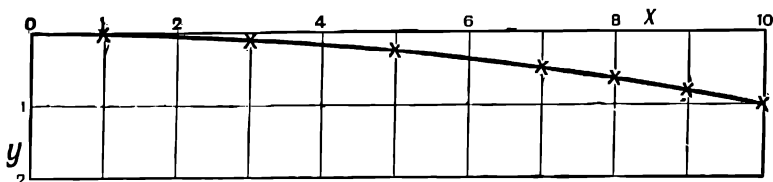

FIG. 50.

EXAMPLE (2).—If the mixture in a gas-engine expands without gain or loss of heat, it is found that the law of expansion is given by the equation $p v^{1.37} = \text{constant}$, where p is the pressure and v the volume.

Plot a curve to show the pressure at any volume as the gas expands from $v = 11$ to $v = 23$, having given that $p = 188.2$ when $v = 11$.

Problems dealing with this subject are sometimes treated as though the gas expanded according to Boyle's law, i.e. as though $p v = \text{constant}$.

On the same paper plot a curve to show the pressure at any volume as the gas expands according to the law $p v = \text{constant}$, starting with the same values of p and v .

$$\text{We have } p v^{1.37} = C$$

Taking logs,

$$\log p + 1.37 \log v = \log C$$

When $p = 188.2$, $v = 11$, then $\log p = 2.2747$, $\log v = 1.0414$

$$\therefore \log C = 2.2747 + 1.427 = 3.7017$$

From this we get

$$\log p = 3.7017 - 1.37 \log v$$

and the values of p can be calculated as follows:—

v	11	12	13	14	16	18	20	23
$\log v$	—	1.0792	1.1139	1.1461	1.2041	1.2553	1.3010	1.3617
$\log p$	—	2.223	2.175	2.131	2.052	1.982	1.919	1.837
p	188.2	167.1	149.6	135.2	112.7	95.8	83	68.7

If the gas expands according to Boyle's law we have $p v = \text{constant} = C_1$.

To find C_1 , we have when $v = 11$, $p = 188.2$.

$$\therefore C_1 = 11 \times 188.2 = 2070$$

$$\therefore p v = 2070; p = \frac{2070}{v}$$

The values of p can now be calculated as follows:—

v	11	13	15	17	19	21	23
p	188.2	159.9	138	121.8	109	98.6	90

The two curves obtained by plotting these two sets of corresponding values of p and v are shown in Fig. 51.

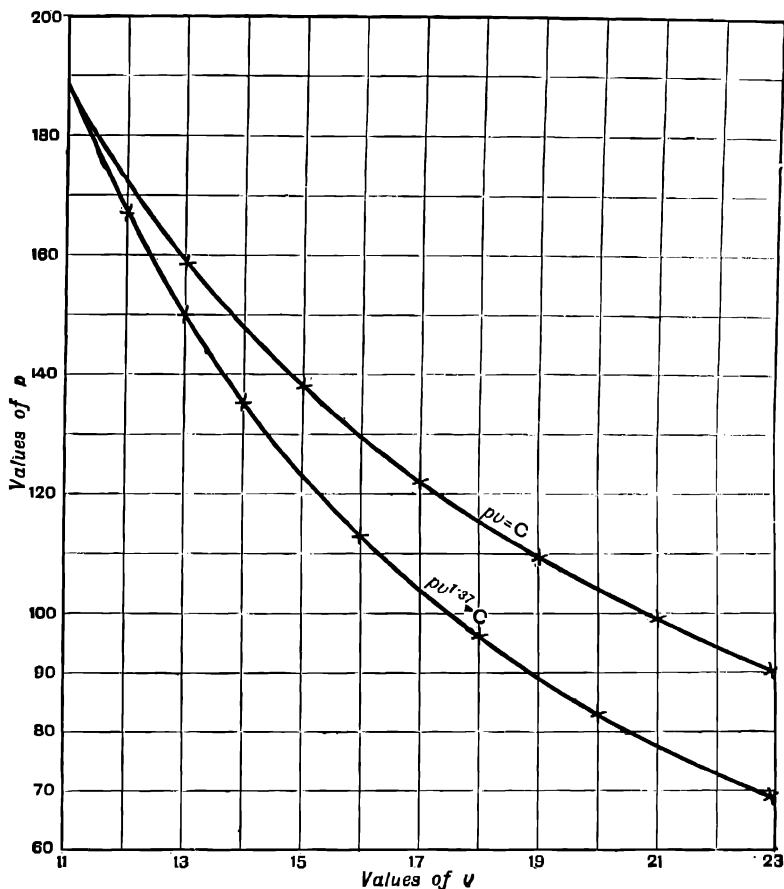

FIG. 51.

The following example is of special interest to students of chemistry and physics.

EXAMPLE (3).—Boyle's law states that a gas at constant temperature expands according to the law $pv = C$, or, if we choose suitable units, $pv = 1$. When the gas is near to the liquid state this equation ceases to be sufficiently accurate. According to van der Waals, a more exact law is

$$\left(p + \frac{a}{v^2}\right)(v - b) = 1 + \frac{t}{273}$$

where a and b are small constants and t is the temperature centigrade.

For carbon dioxide $a = 0.00874$, $b = 0.0023$.

Plot a curve showing the relation between p and v from $v = 0.004$ to $v = 0.03$ for the case $t = 0$.

Also plot the curve $pv = 1$ on the same paper, and compare.

$$\text{We have } \left(p + \frac{0.00874}{v^2} \right) (v - 0.0023) = 1$$

$$p = \frac{1}{v - 0.0023} - \frac{0.00874}{v^2}$$

Values of p are calculated as follows:—

v .	$\frac{1}{v - 0.0023}$	$\frac{0.00874}{v^2}$	$\frac{1}{v - 0.0023} - \frac{0.00874}{v^2} = p$
0.004	588.3	546.2	42.1
0.030	36.1	9.71	26.39
0.005	370.3	349.6	20.7
0.006	270.2	243.0	27.2
0.008	175.4	136.6	38.8
0.010	129.8	87.4	42.4
0.015	78.7	38.4	40.3
0.020	56.5	21.8	34.7
0.025	44.05	13.98	30.07

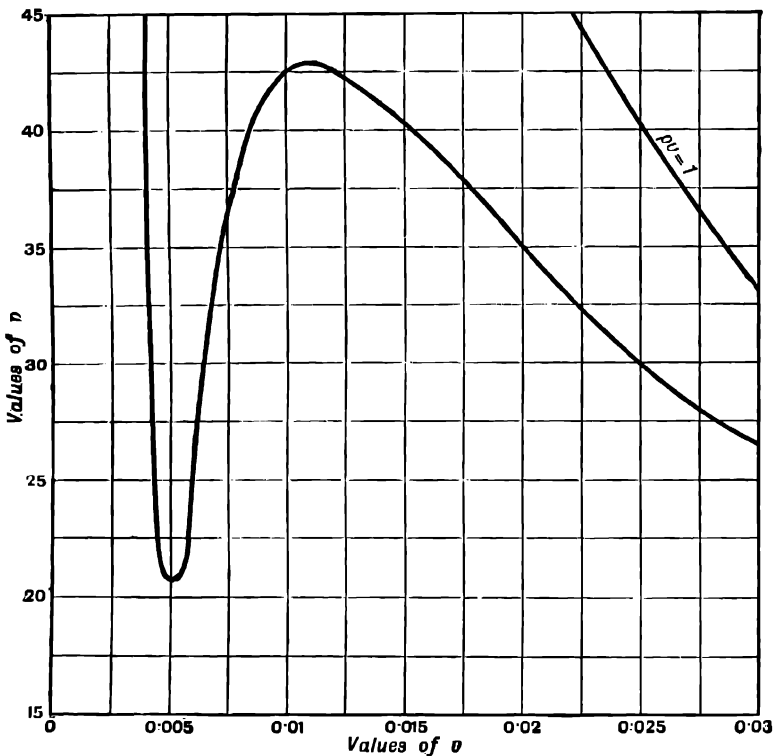

FIG. 52.

The curve obtained by plotting these values, and also a portion of the curve $pv = 1$, is shown in Fig. 52.

EXAMPLE (4).—A wrought-iron tube of 1-in. radius inside, and 3-in. radius outside is subjected to a fluid pressure of 6000 lbs. per square inch inside. If the pressure

on the outside is 0, draw a curve showing the tensile stress ($-q$) at all points within the material of the tube. Given $p = a + \frac{b}{r^2}$, $q = a - \frac{b}{r^2}$, where a and b are constants, r is the distance from the centre of the tube, and p is the pressure on the inside or outside of the tube.

To find a and b , we have

when $r = 1$, $p = 6000$; when $r = 3$, $p = 0$

$$\therefore \text{substituting } 6000 = a + b; 0 = a + \frac{b}{9}$$

$$\therefore \frac{8}{9}b = 6000; b = 6750$$

$$a = -750$$

We can now calculate the values of $-q$ for different values of r from the formula

$$-q = 750 + \frac{6750}{r^2}$$

r .	$\frac{6750}{r^2}$	$750 + \frac{6750}{r^2} = -q$
1	6750	7500
2	1687.5	2437.5
3	750	1500
1.3	3990	4740
1.7	2340	3090
1.5	3000	3750
1.1	5580	6330
2.5	1080	1830

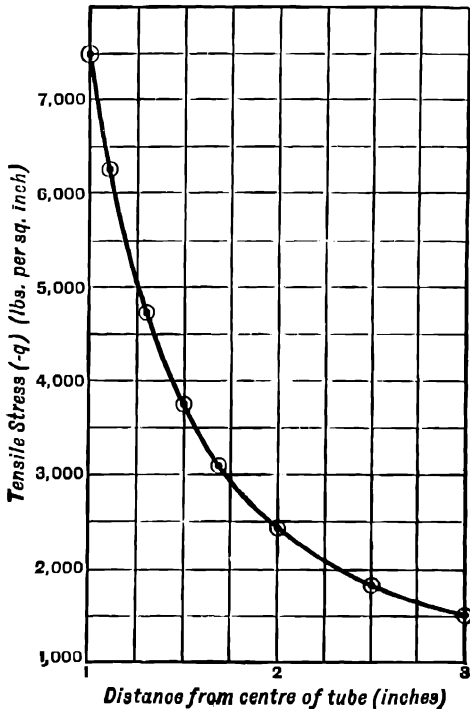

FIG. 22.

EXAMPLES.—XXXIX.

1. Plot the following curves together on the same sheet of paper, from $v = 1$ to $v = 10$, taking values of v as abscissæ and values of p as ordinates:—

$pv^{1.41} = C_1$, $pv^{1.3} = C_2$, $pv^{0.9} = C_3$, $pv = C_4$, where C_1, C_2, C_3, C_4 , are constants.

In every case it is given that $p = 3000$ when $v = 1$.

2. The relation between the pressure in pounds per square inch and the volume in cubic feet of one pound of saturated steam is given by the equation $pv^{1.0640} = 479$.

Plot a curve to show the pressure for any volume from $v = 4.57$ to $v = 25.87$.

3. If t is the absolute temperature, and v the volume of a gas, then in adiabatic expansion, $tv^{\gamma-1} = \text{constant}$.

Plot a curve showing how v depends upon t for air ($\gamma = 1.41$) from $t = 300$ to $t = 400$, having given that $v = 1$ when $t = 400$.

4. If p is the pressure and t the absolute temperature of a gas in adiabatic expansion, then $t^{\frac{\gamma}{1-\gamma}}p = \text{constant}$.

Plot a curve to show how p depends upon t for air from $t = 300$ to $t = 400$, having given that $p = 3500$ when $t = 400$; $\gamma = 1.41$.

5. D is the diameter of a wrought-iron shaft to transmit indicated horse-power H at N revolutions per minute.

$$D = \sqrt[3]{\frac{65H}{N}}$$

Plot a curve showing the relation between D and H , from $H = 10$ to $H = 80$, when N is 100 revolutions per minute. From your curve find the diameters for horse-powers of 27 and 63.

6. The British Association rule for pitch and diameter of screw threads for instruments is $d = 6p^{\frac{5}{8}}$, where d is the diameter and p the pitch.

Plot a curve to show the diameter for any pitch from 0.004 to 0.02.

7. The tensile stress ($-q$) in a certain cylinder is given by $-q = 4680 + \frac{117,000}{r^2}$.

Plot a curve showing the value of $-q$ for any value of r from 3 to 5.

8. A tube 3 ins. internal and 8 ins. external diameter is subjected to a collapsing pressure of 5 tons per square inch; show by curves the radial and circular stresses everywhere.

Given that, at a point distant r inches from the axis of the cylinder,

$$\text{the radial stress } p = A + \frac{B}{r^2}$$

$$\text{the circular stress } q = A - \frac{B}{r^2}$$

Note that p is 5 tons per square inch when $r = 4$ ins., and $p = 0$ when $r = 1.5$ ins. (*Board of Education Examination in Applied Mechanics, 1901.*)

9. In the case of a uniform beam of length l fixed at one end, and carrying a uniformly distributed load w per unit length, the deflection y at the distance x from the fixed end is given by

$$y = \frac{w}{24EI} (6l^2x^2 - 4lx^3 + x^4)$$

Draw a curve to show the deflection at any point of a beam 10 ft. long which is deflected 1 ft. at the free end.

10. The deflection y at a distance x from the middle of a uniformly loaded beam supported at the two ends is given by

$$y = \frac{w}{48EI} (3l^2x^2 - 2x^4)$$

y is measured upwards from the level of the middle of the beam.

Plot a curve to show the shape of the beam, given $l = 10$ ft., deflection at the middle = 1 ft.

11. The equation to a parabola is $y^2 = 4ax$.

Plot this between $x = 0$ and $x = 4$, for the cases where $a = 1$, $a = 2$, $a = 3$.

12. The equation to an ellipse is $\frac{x^2}{a^2} + \frac{y^2}{b^2} = 1$.

Plot the whole curve for the following cases: $a = 3$, $b = 2$; $a = 3$, $b = 1$; $a = 4$, $b = 3$; $a = 1$, $b = 1$.

13. The equation to a hyperbola is $\frac{x^2}{a^2} - \frac{y^2}{b^2} = 1$.

Plot the curve from $x = -12$ to $x = +12$ for the same values of a and b , as in example 12.

14. Calculate the amount of £100 at 3 per cent. compound interest in 5, 10, 15, and 20 years.

Plot a curve from these values to show the amount for any number of years from 1 to 20. From your curve find (1) the amounts of £100 in 3 and 7 years respectively, (2) in how many years would £520 amount to £611 10s.

15. The present value of an annuity of £P per annum for n years, with interest at r per cent., is given by

$$V = \left\{ 1 - \left(\frac{100 + r}{100} \right)^{-n} \right\} \frac{100P}{r}$$

Plot curves showing the present value of an annuity of £1 (a) at 3 per cent. per annum, for periods varying from 1 year to 50 years; (b) for 30 years at rates varying from 1 to 5 per cent.

16. The velocity v ft. per second at which water will flow through a pipe of diameter d ft. with a fall of 1 in 10 is given by the empirical formula

$$v = 140 \left(\frac{d}{40} \right)^{\frac{1}{2}} - 11 \left(\frac{d}{40} \right)^{\frac{3}{2}}$$

Plot a curve to show the value of v for pipes from 1 in. to 12 ins. diameter. From your curve read off the velocity for a pipe of 2.5 ins. diameter.

17. The following formulæ have been given for the shape of high dams in masonry for reservoirs:

$$y = \sqrt{\frac{0.05x^3}{P + 0.03x}} \quad z = \left(\frac{0.09x}{P} \right)^{\frac{1}{4}}$$

x is the vertical depth below the surface of the water in feet.

y is the horizontal distance of a point on the outer face from a vertical line through the top of the inner face.

z is the vertical distance of a point on the inner face from the same vertical line.

P = maximum pressure allowed in tons per square foot.

Plot curves to show the cross-section of the inner and outer faces of the dam from $x = 40$ to $x = 160$. Maximum pressure allowed = 7 tons per square foot.

18. e is the commercial efficiency of an electric motor when the current is I amperes

$$e = \frac{EI - I^2r - P_0}{EI}$$

For a certain motor $E = 122.4$; $r = 0.024$; $P_0 = 2887$.

Plot a curve to show the efficiency for all values of I from 40 amperes to 160 amperes. By means of your curve find the efficiency for a current of 86 amperes.

19. The current I amperes required by a motor of the same type as in the last question for a load P_s watts is given by the formula

$$I = \frac{E - \sqrt{E^2 - 4r_a(P_s + P_0)}}{2r_a}$$

For a particular motor the full load is 746×15 watts, $E = 125$, $r_a = 0.024$, $P_s = 2000$.

Plot a curve to show the current taken for any load from one quarter of the full load to $1\frac{1}{2}$ times the full load. What current would be taken for $\frac{3}{4}$ load and for $1\frac{1}{2}$ load?

20. T is the rise in temperature in degrees Fahrenheit of an electric transformer when m watts are wasted per square inch of cooling surfaces.

For an air-cooled transformer $T = 300m^{\frac{2}{3}}$.

For an oil-cooled transformer $T = 225m^{\frac{2}{3}}$.

Plot on the same sheet two curves to show the value of T in air and oil-cooled transformers respectively, for any value of m between $m = 0$, and $m = 0.4$.

What is the waste in watts per square inch for a rise in temperature of 60° for an oil-cooled transformer? (W. B. Woodhouse, *Electrician*, Feb. 15, 1901.)

21. w is a certain linear dimension used to determine the size of a transformer core. S is the corresponding area of the cooling surface.

The outside breadth of the core = $3.2w + 1$ in.

The outside length of the core = $4.6w + 4$ ins.

$$S = 145.5w^2 + 120w$$

$$\text{weight of iron} = 2.07w^3 + 1.78w^2$$

On the same sheet plot curves to show the cooling surface and the weight for all values of w from 0 to 6 ins.

By means of your curve find the length and breadth of a core, and the weight of iron, to give a cooling surface of 2140 sq. ins.

(W. B. Woodhouse, *Electrician*, March 1, 1901.)

66. **Compound Interest Law** $y = ae^{bx}$.—In nature we often meet with related pairs of quantities which obey a law of the form $y = ae^{bx}$.

a and b are constants, and the quantity e , which is the base of Napierian logarithms, is numerically equal to 2.7183 The nature and importance of this quantity e will be more fully explained in Chapter XXIX. It can be shown that when y and x are related by the above law, the rate of increase of y per unit increase of x is proportional to y , so that y increases relatively to x , like a sum of money at compound interest if the interest is added to the principal continuously instead of once a year.

The law $y = ae^{bx}$ is called the **compound interest law**.

We shall first take the case where $a = 1$, $b = 1$.

EXAMPLE (1).—Plot the curve $y = e^x$ from $x = -4$ to $x = 2$.

Taking logs of both sides of the equation $y = e^x$

$$\text{we have } \log_{10} y = x \log_{10} e = 0.4343x$$

x .	$0.4343x = \log y$.	y .
0	—	1.0
1	—	2.718
2	0.8686	7.390
-4	2.2628	0.018
-1	—	0.368
-2	—	0.135
-3	2.6971	0.0498
0.4	0.1737	1.490
1.4	0.608	4.050
-0.4	—	0.670

Plotting these values, we get the curve **A** (Fig. 54).

NOTE 1.—Since $e^{-x} = \frac{1}{e^x}$, the values of y when $x = -1$, $x = -2$, and $x = -0.4$ in the above table, need not be calculated directly by logarithms, but are the reciprocals of the values of y for $x = 1$, $x = 2$, and $x = 0.4$. Similarly in any case the values of y for negative values of x are the reciprocals of the values of y for positive values of x .

NOTE 2.—The value of a in the equation $y = ae^{bx}$ only affects the vertical scale on which the curve is plotted.

NOTE 3.—When we have plotted the curve $y = e^{bx}$ for any value of x , the curve $y = e^{-bx}$ may easily be obtained from it. The equation may be written $y = e^{b(-x)}$, and may be obtained from the equation $y = e^{bx}$ by substituting $-x$ for x . Therefore,

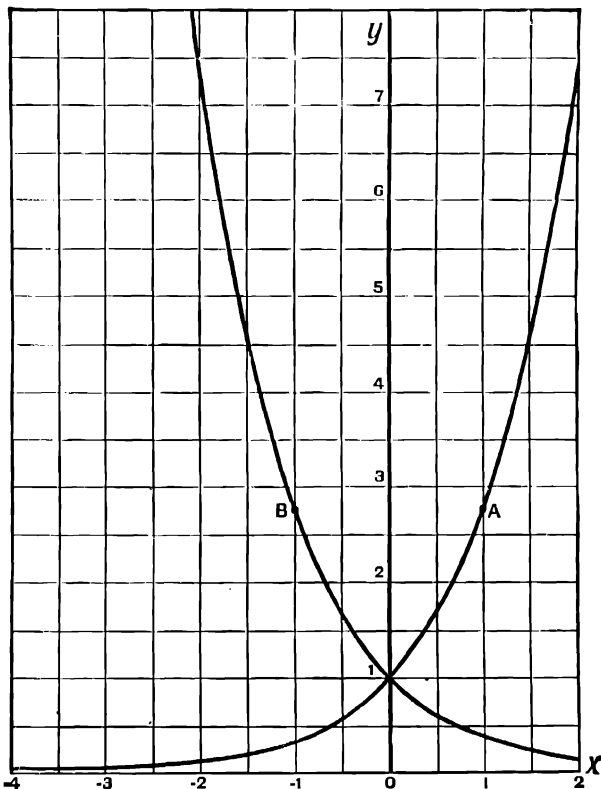

FIG. 54.

if for every ordinate we mark off abscissæ equal in numerical magnitude, but in the opposite direction to the abscissæ of the curve $y = e^{bx}$, we shall obtain the curve $y = e^{-bx}$.

The curve $y = e^{-x}$ is given in Fig. 54, e.g. we found that, in the curve $y = e^x$, when $y = 2.718$, $x = 1$. Therefore, in the curve $y = e^{-x}$, when $y = 2.718$, $x = -1$.

We thus obtain the point B in the second curve from the point A in the first curve, and so on.

Note that the curve $y = e^{-bx}$ is the reflection of $y = e^{bx}$ in a mirror. The two curves are symmetrical about the axis of y . They are related in the same way as a piece of writing and its imprint on blotting paper.

Also since $e^{-bx} = \frac{1}{e^{bx}}$ we might plot the curve $y = e^{-bx}$ by finding the reciprocals of the ordinates of $y = e^{bx}$.

NOTE 4.—When $y = e^x$ we have, by the definition of a logarithm, $x = \log_e y$, so that the curve $y = e^x$ may also be used to find logarithms to base e , e.g., to find $\log_e 3$; we see by inspection of Fig. 54 that when $y = 3$, $x = 1.1$, therefore $\log_e 3 = 1.1$. Similarly we find $\log_e 1.5 = 0.4$. These values are correct to two places of decimals, the true values being 1.098 and 0.405.

By drawing a portion of this curve on a large scale we might use it to find logarithms to base e to any desired degree of accuracy. This is merely given as an illustration; it is not, of course, an independent way of calculating logarithms to base e , as we have used a table of logs to construct the curve.

EXAMPLE (2).—Plot the curves $y = e^{\frac{1}{3}x}$, $y = e^{-\frac{1}{3}x}$, $y = e^{3x}$, $y = e^{-3x}$, between $x = -3$ and $x = +3$ on the same paper, and compare.

$$(a) y = e^{\frac{1}{3}x}$$

Taking logs

$$\log y = \frac{1}{3}x \log e = \frac{0.4343}{3}x = 0.1448x$$

x .	$0.1448x = \log y$.	y .
0	—	1.0
3	—	2.718
-3	—	0.368
1	0.1448	1.396
2	0.2896	1.948
-1	0.1448	0.716
-2	0.2896	0.513

Note that there are always three points in the curve $y = e^{bx}$ which may be found very easily. When $x = 0$, $y = 1$; when $x = \frac{1}{b}$, $y = e = 2.718$; when $x = -\frac{1}{b}$, $y = e^{-1} = \frac{1}{2.718} = 0.368$.

These points should be plotted first, to gain a general idea of the shape of the curve.

The reflection of $y = e^{\frac{1}{3}x}$ gives $y = e^{-\frac{1}{3}x}$.

$$(b) y = e^{-\frac{1}{3}x}$$

Taking logs,

$$\log y = -\frac{1}{3}x \log e = -0.1448x$$

x .	$-0.1448x = \log y$.	y .
0	—	1.0
3	—	2.718
-3	—	0.368
1	0.1448	20.1
0.1	0.1448	1.35
-0.1	0.1448	0.7408
-1	0.1448	0.05
-2	0.2896	0.0025
0.7	0.1014	8.168
-0.7	0.1014	0.122
0.5	0.0724	4.472
-0.5	0.0724	0.223

The reflection of the curve thus obtained is the curve $y = e^{-3x}$.

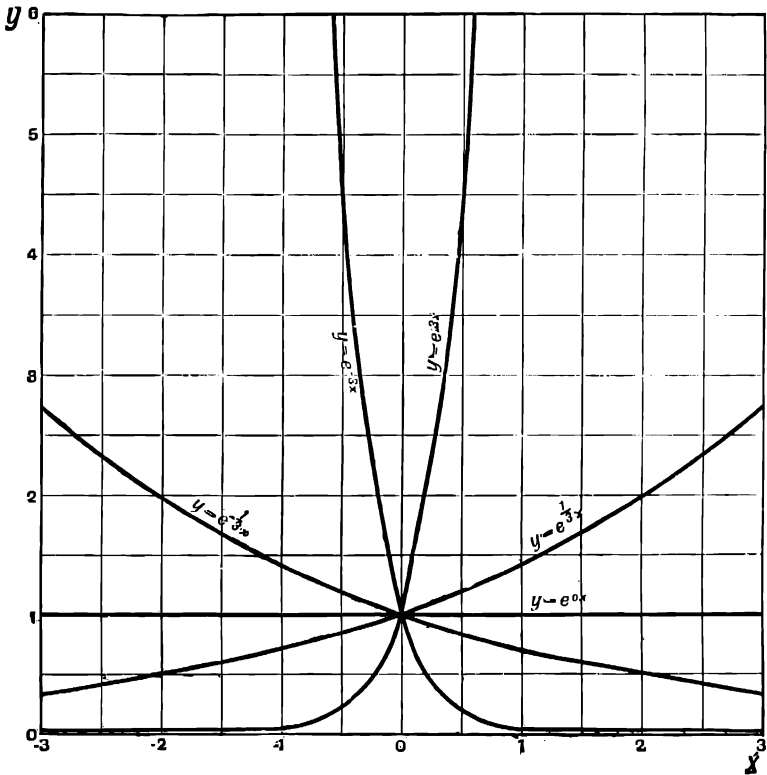

FIG. 55.

Ø7. Any curve whose equation is of the form $y = c^x$ where c is any number, belongs to the class here considered; for, by the definition of a logarithm, $e^{\log_e c} = c$.

$$\therefore c = e^{(\log_e c)x}$$

and the equation $y = c^x$ may be written $y = e^{(\log_e c)x}$, which is of the form $y = e^{bx}$ if $b = \log_e c$.

For example, $\log_e 10 = 2.3026$; i.e. $e^{2.3026} = 10$, so that the equation $y = 10^x$ may be written $y = e^{2.3026x}$.

Thus the curve $y = 10^x$ is the same as $y = e^{bx}$ for the case when $b = 2.3026$.

In the curve $y = 10^x$, $x = \log_{10} y$, and the curve may be used to find common logs if drawn on a sufficiently large scale.

EXAMPLES.—XL.

1. Plot the curves $y = e^{2x}$ and $y = e^{-2x}$ between $x = -1$ and $x = +1$.
2. Plot the curves $y = e^{\frac{1}{2}x}$ and $y = e^{-\frac{1}{2}x}$ between $x = -4$ and $x = +4$, and on the same paper plot the curve $y = e^{bx}$ for the case when $b = 0$.

3. Plot the curves $y = e^{10x}$, $y = e^{-10x}$, $y = e^{10^x}$, $y = e^{-10^x}$, between $x = -1.1$ and $x = +1.1$.

4. Plot the curves $y = e^{4x}$, $y = e^{4.5x}$, $y = e^{5x}$, on the same paper between $x = 0$ and $x = 1$.

5. Plot the curves $y = e^{2x}$, $y = 2e^{2x}$, $y = 3e^{2x}$, on the same scale between $x = 0$ and $x = 2$.

6. Find the values of $10^{\frac{1}{2}}$, $10^{\frac{1}{4}}$, $10^{\frac{1}{8}}$, $10^{\frac{1}{16}}$, by finding square roots in succession without using logs. By multiplying these values obtain $10^{\frac{3}{8}}$, $10^{\frac{5}{8}}$, $10^{\frac{7}{8}}$, etc. . . . Using these values plot the curve $y = 10^x$ from $x = 0$ to $x = 1$. From your curve find the common logarithms of 2, 3, 4, 5, 6, 7, 8, 9; and compare them with the values given in the tables.

88. We shall now give some examples of curves of type $y = ae^{bx}$, which occur in physical science.

EXAMPLE.—*Newton's law of cooling.*

A body is heated to a temperature θ_1 above the surrounding bodies, and suspended in air. Its excess of temperature θ at any time t seconds afterwards is given by $\theta = \theta_1 e^{-at}$, where a is a constant. For a certain thermometer bulb suspended in air, it was found that $a = 0.0155$, $\theta_1 = 19.32^\circ$. Plot a curve showing the temperature at any time t .

$$\text{We have } \theta = \theta_1 e^{-at} = 19.32e^{-0.0155t}$$

$$\begin{aligned} \therefore \log_{10} \theta &= -0.0155t \times \log_{10} e + \log_{10} 19.32 \\ &= -0.00673t + 1.2860 \end{aligned}$$

t .	$-0.00673t$.	$-0.00673t + 1.2860 = \log \theta$.	θ .
0			19.32
10	-0.0673	1.287	16.55
20	-0.1350	1.151	14.16
30	-0.2025	1.0835	12.12
40	-0.2700	1.0160	10.38
60	-0.4050	0.881	7.59
80	-0.5400	0.746	5.57
100	-0.675	0.611	4.08
120	-0.810	0.476	2.99

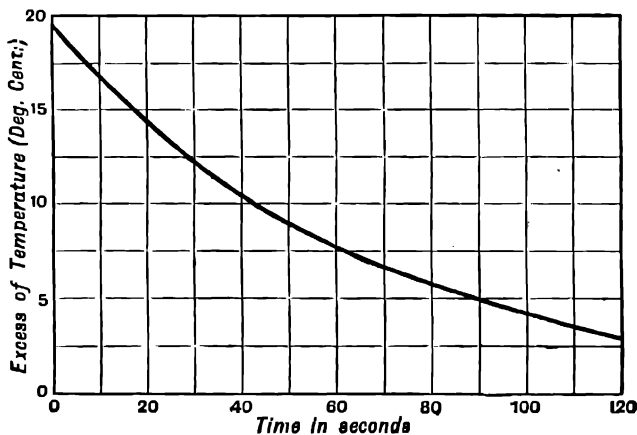

FIG. 56.

69. The Catenary.—The form of a uniform flexible cord or wire, such as a telegraph or trolley wire suspended between two fixed points, is given by the equation

$$\frac{y}{c} = \frac{e^{\frac{x}{c}} + e^{-\frac{x}{c}}}{2}$$

where $c = \frac{\text{horizontal tension}}{\text{weight per unit length of wire}}$

This curve is called the catenary.

EXAMPLE.—A copper wire, weighing 0.405 lbs. per yard, is suspended between two points, 20 yds. apart, under a tension of 5.06 lbs. Plot a curve to show its shape.

$$\text{Here } c = \frac{5.06}{0.405} = 12.5$$

We shall first plot the curve

$$y = \frac{e^x + e^{-x}}{2}$$

in which $c = 1$.

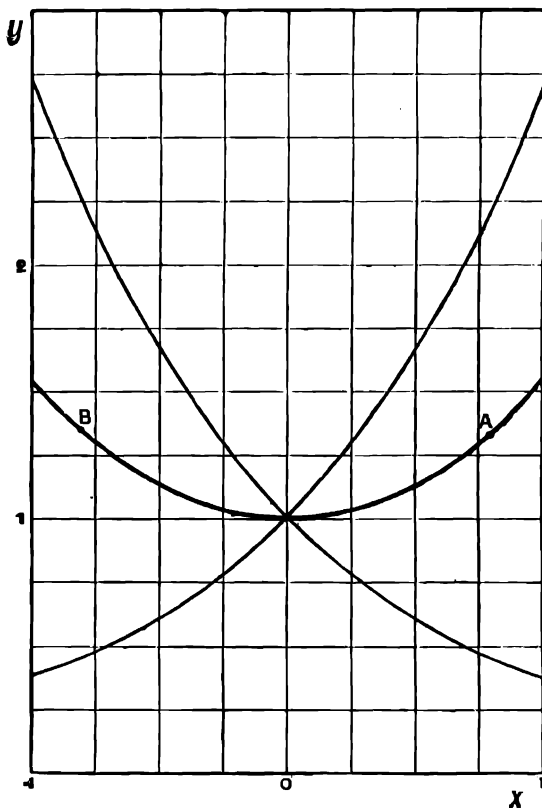

FIG. 57.

In this case y is the arithmetic mean of the ordinates of the curves $y = e^x$ and $y = e^{-x}$. Accordingly, we plot these two curves as in example 1, p. 104, and, by bisecting the ordinates intercepted between them, obtain points on the required catenary. We shall only require the portions of these curves between $x = \pm 1$, which we plot on a large scale.

If we suppose that the unit length on the axes of x and y in Fig. 57 now represents 2 instead of 1, then, for any point on the curve, the value of y measured on the old scale is half of the value of y on the new scale, and similarly for x .

But the values of x and y on the old scale were connected by the equation

$$y = \frac{1}{2}(e^x + e^{-x})$$

therefore, if measured on the new scale, they satisfy the equation

$$\frac{y}{2} = \frac{1}{2}(e^{\frac{x}{2}} + e^{-\frac{x}{2}})$$

Similarly, if we suppose that the unit length on the axis in Fig. 57 represents a length c , the equation to the curve is now

$$\frac{y}{c} = \frac{1}{2}(e^{\frac{x}{c}} + e^{-\frac{x}{c}})$$

In the given case, $c = 12.5$, and therefore the unit on the axes must represent 12.5 yds.

The span of 20 yds. is represented by $AB = \frac{20}{12.5} = 1.6$ units, and the shape of the wire is shown by the portion of the curve between **A** and **B**.

To represent a practical case, such as that of telegraph wire, having a span of 100 yds., and tension 506 lbs., we should have $c = 1250$; and therefore the span would be represented by $\frac{100}{12.50} = 0.08$ unit in Fig. 57. To show this we should have to draw on a large scale a small portion of the curve where it crosses the axis of y .

EXAMPLES.—XLI.

1. The excess θ of the temperature of a body above that of its surroundings at time t seconds is given by the equation $\theta = \theta_1 e^{-at}$, where θ_1 and a are constants.

If $\theta = 26^\circ$ when $t = 0$, and $\theta = 9^\circ$ when $t = 10$ secs., plot a curve to show the temperature at any time from $t = 0$ to $t = 20$ secs.

2. A wire is stretched to a tension of 10 lbs., and weighs 2.27 lbs. per foot. Draw a curve showing the form of the wire.

3. A long thin bar is heated at one end. If t be the excess of its temperature above that of the surrounding air at a distance x from the heated end, it can be proved that $t = A e^{-bx}$ where A and b are constants.

Given that $t = 65^\circ$ where $x = 0$, and $t = 60^\circ$ where $x = 30$ cm.; plot a curve to show the temperature at every point of the bar to a distance of 1 metre from the heated end.

4. It is found by experiment that on the C.G.S. system of units, the viscosity μ of olive oil at temperature θ° C. is given by $\mu = 3.2653e^{-0.0123\theta}$. Plot a curve to show the viscosity at any temperature from 16° C. to 49° C.

5. If s is the relative viscosity of common salt solution when its concentration is the fraction x of that of the normal salt solution, then $s = 1.0986^x$. Plot a curve to show the relative viscosity of salt solution for values of x varying from 0 to 1.

6. If the impressed electro-motive force is suddenly removed from an electrical circuit containing resistance and self-induction, the current dies down gradually in a way given by the equation $i = i_0 e^{-\frac{Rt}{L}}$, where i is the current at time t after the E.M.F. has been removed, R is the resistance, and L the coefficient of self-induction. Plot a curve to show the current at any time from 0 to 0.1 sec. for a circuit in which $i_0 = 20$ amps., $R = 0.2$ ohm, $L = 0.005$ henry.

7. A condenser is discharging through a circuit containing self-induction and resistance. The potential v at time t is given by $v = 1145e^{-1.125 \times 10^4 t} - 145e^{-8.975 \times 10^4 t}$.

Plot a curve to show the value of v at any time from $t = 0$ to $t = 2 \times 10^{-4}$.

B. The entropy of 1 lb. of air at pressure p lbs. per sq. foot, volume v cu. feet, and absolute temperature t° (Fahr.) is given by

$$\phi = 0.1688 \log_e \frac{p}{2116} + 0.2375 \log_e \frac{v}{12.39} \dots \dots \dots (a)$$

$$\phi = 0.2375 \log_e \frac{t}{493} - 0.0687 \log_e \frac{p}{2116} \dots \dots \dots (b)$$

$$\phi = 0.1688 \log_e \frac{t}{493} + 0.0687 \log_e \frac{v}{12.39} \dots \dots \dots (c)$$

(a) A pound of air is heated from absolute temperature 493° (Fahr.) to absolute temperature 673° (Fahr.), at constant pressure 2116 (atmospheric). Plot a curve to show the entropy for any temperature throughout the above range. (Use equation b.)

(b) During the above change of temperature the volume changes from 12.39 to 16.9. Plot a curve to show the entropy for any volume throughout this range. (Use equation a.) Note that this curve is of the same shape as the curve in a, but has a different scale for the abscissæ. This is because the volume of a perfect gas at constant pressure is proportional to the temperature.

(c) A pound of air, at volume 12.39 cu. ft., atmospheric pressure 2116, temperature 493, is kept in a closed vessel, and heated till its pressure is 4232 (two atmospheres). Plot a curve to show its entropy for any pressure between 2116 and 4232.

(d) The temperature becomes 986 during the above change of pressure. Plot a curve to show the entropy for any temperature during this change.

(e) The temperature is kept constant, and the pressure is increased to 4232. Plot a curve to show the entropy as a function of the pressure from $p = 2116$ to $p = 4232$. Note that this curve is quite different from that of example c.

(f) While the pressure is doubled in the last example, the volume becomes 6.195 cu. ft. Plot a curve to show the entropy for any volume between 12.39 and 6.195.

B. From the equation (c) above, plot t , ϕ , curves having values of t as ordinates, and values of ϕ as abscissæ, from $t = 493$ to $t = 673$,

- (1) when v is constant and equal to 12.39;
- (2) " " " " 24.78;
- (3) " " " " 6.195.

10. The entropy ϕ of 1 lb. of dry saturated steam is given by

$$\phi = \log_e \frac{t}{274} + \frac{797}{t} - 0.695$$

where t is the absolute temperature Centigrade. Plot a curve having values of t as ordinates and values of ϕ as abscissæ from $t = 274$ to $t = 474$.

70. Curves represented by the Equation $y = a \sin (cx + d)$.

We shall consider separately the three constants a , c , and d in this equation.

(I.) **Period.**—To find the meaning of the constant c in the equation $y = a \sin (cx + d)$.

We shall plot curves whose equations have different values of c , but are the same in other respects.

Take $a = 1$, $d = 0$. Then $y = \sin cx$.

(a) Let $c = 1$.

The equation is now

$$y = \sin x$$

The values of y for different values of x may here be read off directly from the tables so long as the angle is in the first quadrant.

In Chapter II. we have seen that as the generating line of the angle x passes through the second quadrant with increasing x , $\sin x$ passes back through the same positive values from 1 to 0. In the third and fourth quadrants we have the same numerical values but with negative signs.

When x reaches the value 360° its generating line has passed through the

four quadrants, and $\sin x$ begins again at 0 and passes through the same values in the same order as before. Thus the curve repeats itself indefinitely.

We here take x in degrees. When the curve is required so that the angle is expressed in radians, the necessary change may be made in the scale of the axis of x .

We get the curve *a*, Fig. 58.

(*b*) Let $c = 2$.

The equation is now

$$y = \sin 2x$$

Values of y as x increases from 0° to 90° are given in the following table:—

x degrees .	0	9	18	27	36	45
$\sin 2x = y$	0	0.309	0.588	0.809	0.951	1
x degrees .	90	81	72	63	54	45

When two values of x , such as 18° and 72° in the above table, are complementary, the values of $2x$ are supplementary, and have the same sine.

As x increases from 90° to 180° , $2x$ increases from 180° to 360° , and its generating line passes through the third and fourth quadrants; therefore we get the same numerical values for $\sin 2x$ as in the table, but with negative signs.

We thus get the curve *b*, Fig. 58. The curve repeats itself indefinitely.

(*c*) Let $c = \frac{1}{2}$.

The equation is now

$$y = \sin \frac{1}{2}x.$$

Values of y as x increases from 0° to 360° are given in the following table:—

x degrees	0	18	36	54	72	90	108	126	144	162	180
$\sin \frac{1}{2}x$.	0	0.156	0.309	0.454	0.588	0.707	0.809	0.891	0.951	0.988	1
x degrees	360	342	324	306	288	270	252	234	216	198	180

When two values of x , such as 108° and 252° in the above table, are together equal to 360° , the values of $\frac{1}{2}x$ are supplementary, and have the same sine.

As x increases from 360° to 720° the angle $\frac{1}{2}x$ increases from 180° to 360° , and its generating line passes through the third and fourth quadrants. Its sine will therefore pass through the same numerical values as in the above table, but with negative signs.

We thus get the curve *c*, Fig. 58. The curve repeats itself indefinitely.

Comparing these three curves, whose equations are of the form $y = \sin cx$

with different values of c , we see that they are all of the form of waves of the same unit, height, and starting at the same point (0, 0), but of different lengths.

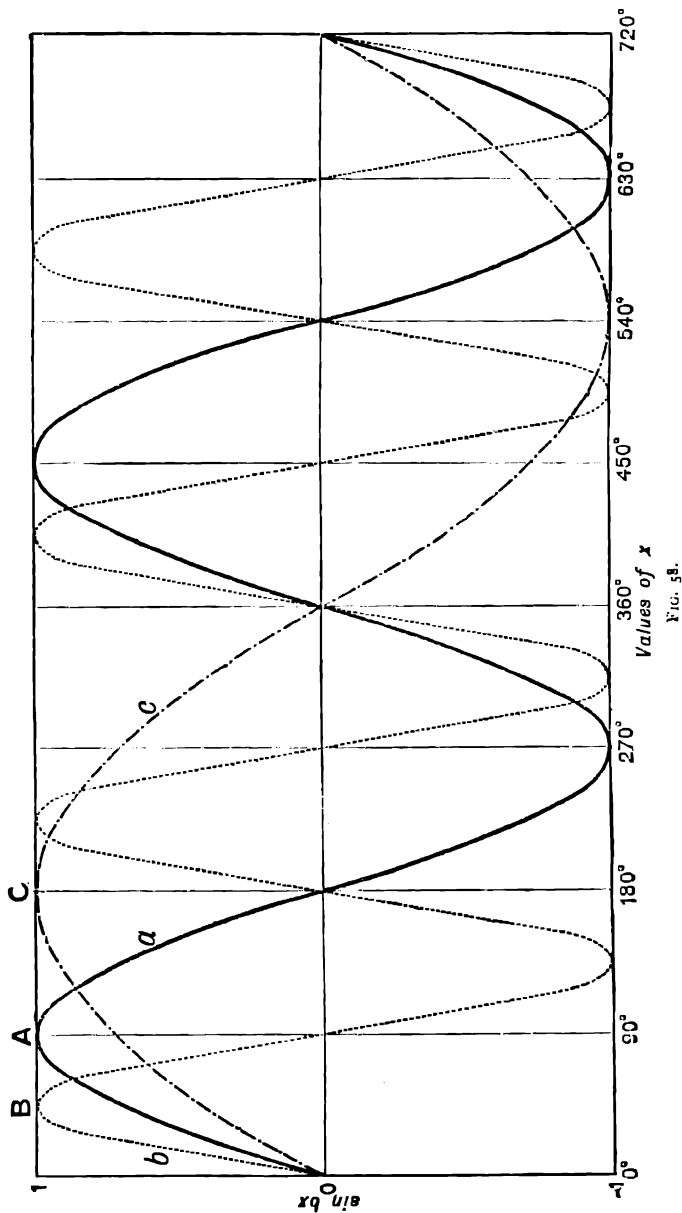

FIG. 5B.

Sine curves, such as these or combinations of different sine curves, may be made to represent a great number of cases in nature, by choosing various meanings of y and x .

If y and x are both lengths, the curves may be used to represent such cases as the form of waves or of a vibrating string. If y denotes length and x time, the curves may be used to represent periodic oscillations, such as those of a spring or pendulum, the motion of a crank, sound waves, etc.

If y denotes the intensity of the electric current through a conductor, and x denotes time, the curves may be used to represent an alternating electric current.

In most practical cases where we meet with the curve $y = a \sin (cx + d)$, the value of the angle $(cx + d)$ is expressed in radians.

71. Wave Length—Periodic Time.—We define the wave length of the curve represented by the equation $y = a \sin (cx + d)$, as the distance between two points where it crosses the axis of x in the same direction. It is understood that the value of $(cx + d)$ is expressed in radians.

E.g. the wave length of the wave represented by $y = \sin x$, where $c = 1$ is 2π , Fig. 58.

If we change c to 2 we get the curve (*b*), whose wave length is $\pi = \frac{2\pi}{2}$.

If we change c to $\frac{1}{2}$ we get the curve (*c*), whose wave length is 4π or $\frac{2\pi}{\frac{1}{2}}$.

In general, we find, in the same way, that the wave length of the curve $y = \sin cx$ is $\frac{2\pi}{c}$.

Let us consider the physical meaning of this in the important case when the abscissa represents time; *e.g.* let the ordinate represent, on a suitable scale, the small displacement of the end of a vibrating spring, and let the abscissa represent the time t . The motion of the spring may be represented by the equation $y = \sin ct$. An oscillation of this kind is a case of **simple periodic** or **simple harmonic** motion.

The time of an oscillation is the time corresponding to a complete wave length of the curve $y = \sin ct$, *i.e.* the time in which the angle ct increases by the amount 2π . After this time has elapsed from the instant $t = 0$, the value of $\sin ct$ goes through the same series of values again, and another oscillation takes place; and so on.

While ct increases by 2π , the time t increases by $\frac{2\pi}{c}$.

I.e. the time of a complete oscillation is $\frac{2\pi}{c}$. This is called the **periodic time** of the simple periodic oscillation.

The **frequency** of an oscillation is the number of complete oscillations which take place in a unit of time.

In the case of the above simple periodic oscillation the frequency is $\frac{c}{2\pi}$.

For example, if the current in a conductor at time t seconds is I ampere, and we know that $I = I_0 \sin (600)t$ where I_0 is constant, then the angle $600t$ increases from 0 to 2π , while t increases by $\frac{2\pi}{600}$ seconds. This is the periodic time.

Frequency = number of oscillations per second

$$= \frac{600}{2\pi} = 96 \text{ nearly}$$

72. (II.) Amplitude.—To find the meaning of the constant a in the curve $y = a \sin (cx + d)$.

In the three curves plotted in Fig. 58 we had a equal to unity. The effect of changing the value of a to 2 or $\frac{1}{2}$ would evidently be to multiply every ordinate in Fig. 58 by 2 or $\frac{1}{2}$ respectively, *i.e.* the curves would still be wave curves of the same length as before, but of twice or one-half the height.

Similarly, in every case a is the height of the wave crest above the axis of x .

When the wave curve represents an oscillation, a is the **amplitude** of the oscillation; *e.g.* in the simple periodic oscillation of a spring the amplitude is the maximum distance to which the spring moves on either side of its equilibrium position.

73. (III.) To find the meaning of the constant d in the curve

$$y = a \sin (cx + d)$$

To trace the curve $y = \sin \left(x + \frac{\pi}{2} \right)$ we may add a right angle to every value of x in the table of sines, so that when $x = 0$, $y = \sin \frac{\pi}{2} = 1$, and so on.

This is equivalent to moving the curve (a), Fig. 58, back through a distance equal to one right angle on the scale on which x is measured, so that the point **A** is on the axis of y .

Similarly, if we change $y = \sin 2x$ to $y = \sin \left(2x + \frac{\pi}{2} \right)$ the curve is of the same shape as before, but begins at $y = \sin \frac{\pi}{2} = 1$. This is equivalent to moving the curve back so that **B** is on the axis of y .

Similarly, $y = \sin \left(\frac{1}{2}x + \frac{\pi}{2} \right)$ is of the same shape as $y = \sin \left(\frac{1}{2}x \right)$, but begins at the point (0, 1), and, in the general case, $y = a \sin (cx + d)$ is of the same shape as $y = a \sin cx$, but begins at $y = a \sin d$ instead of at $y = 0$.

The effect of introducing the constant d is to move the curve back through a distance $\frac{d}{c}$ parallel to the axis of x .

Thus the value of the constant d does not affect the shape of the curve $y = a \sin (cx + d)$, but only its starting-point.

EXAMPLES.—XLII.

1. Plot the curve $y = a \sin cx$ from $x = 0$ to $x = \pi$ radians for the cases when $a = 4$, and c has the values 2, 4, 6 respectively.

2. Plot the curve $y = a \sin cx$ from $x = 0$ to $x = \pi$ for the cases when $c = 2$, and has the values 2, 3, and 4 respectively.

3. Plot the curve $y = a \sin cx$ from $x = 0$ to $x = 10\pi$ when $a = 4$, and c has the values $\frac{1}{2}$, $\frac{1}{4}$, $\frac{1}{5}$ respectively.

4. Plot the curve $y = a \sin (cx + d)$ for the cases when $a = 2$, $c = 2$, and d has the values 0 , $\frac{\pi}{3}$, $\frac{2\pi}{3}$, and π respectively.

74 Simple Periodic Motion.—Simple periodic or simple harmonic motion is the projection on a straight line of uniform circular motion.

If the point **P** moves round a circle in a counter-clockwise direction at a

uniform rate, its projections **M** and **N** on two perpendicular diameters will move backwards and forwards along those diameters with a simple periodic motion.

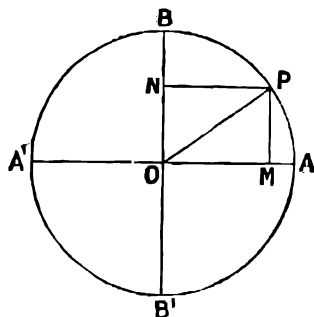

FIG. 59.

EXAMPLE.—A point **P** moves round a vertical circle so that the radius **OP** starts in a horizontal position, and moves with a uniform angular velocity of 0.6981 radian per second. **OP** is of unit length. Plot a curve showing the distance from **O** at any time of the projection of **P** on the vertical diameter.

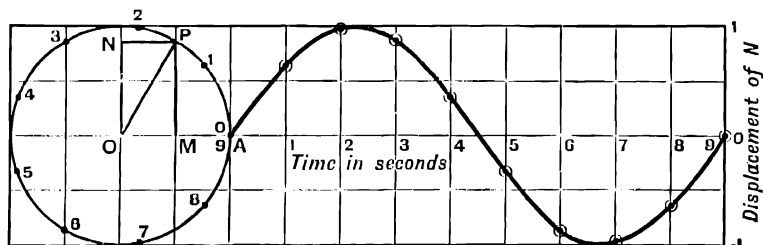

FIG. 60.

Describe a circle of unit radius. In the figure the point **P** starts at **A**. After 1 sec. **OP** has turned through 0.6981 radian = 40° , after 2 secs. through 80° , and so on.

Mark off along the circumference points to show the position of **P** at the end of each second, and number them to show the instant when **P** passes through each point. Then the corresponding positions of **N** are the projections of these points on the vertical diameter.

Take the horizontal diameter **OA** produced as the axis of x , and, starting from **A**, mark off along it a scale of times long enough to show the time taken by **OP** to make a complete revolution.

At the end of each second, plot points whose ordinates are the corresponding distances of **N** from **O**. These points give a curve for which the ordinate s is the displacement of **N**, measured from the mid point of its path, at time t , represented by the abscissa.

The curve evidently repeats itself indefinitely. Since **OP** turns through 0.6981 radian per second, the angle **AOP** is equal to $0.6981t$ radians at time t seconds from starting.

$$\therefore s = \text{ON} = \text{MP} = \text{OP} \sin \text{AOP} = \text{OP} \sin (0.6981t).$$

\therefore for the numerical case taken in this example, where **OP** = 1, the equation to the curve is $s = \sin (0.6981t)$.

In the same way we see, in general, that if a straight line of length a , such as a crank, starts in a horizontal position when $t = 0$, and revolves in a vertical plane round one end at the uniform rate of q radians per second, the projection of the free end on a vertical straight line has a motion which is represented by the equation $s = a \sin qt$.

In the same way $OM = OP \cos AOP = a \cos qt$.

∴ the projection of P on a straight line parallel to the starting-position of OP , oscillates so as to satisfy the law $s = a \cos qt$.

The student will find a simple periodic motion represented sometimes by a sine formula and sometimes by a cosine formula. The motion is evidently the same in the two cases, the difference in the equations only depending on the instant from which we measure the time. If we measure the time from the instant when OP is in the line of the simple periodic motion, we get an equation of the form $s = a \cos qt$; if we measure the time from the instant when OP is perpendicular to the simple periodic motion, we get an equation of the form $s = a \sin qt$.

If OP represents the crank of a vertical engine with a connecting-rod which is very long compared with OP , the motion of the cross-head may be approximately represented by that of N , and, therefore, by the equation $s = a \sin qt$.

If we are given the number n of revolutions per minute instead of the angular velocity, then the crank evidently turns through $\frac{2\pi n}{60}$ radians per second. Therefore, $q = \frac{2\pi n}{60}$ and the equation representing the motion becomes $s = a \sin \frac{2\pi n t}{60}$.

EXAMPLE.—A crank OP of length 5" starts from a position making an angle of 59° with the horizontal line OA at time $t = 0$, and rotates in a vertical plane at a uniform rate of 120 revolutions per minute in a counter-clockwise direction. Plot a curve showing the motion of the projection of P on a vertical line OB .

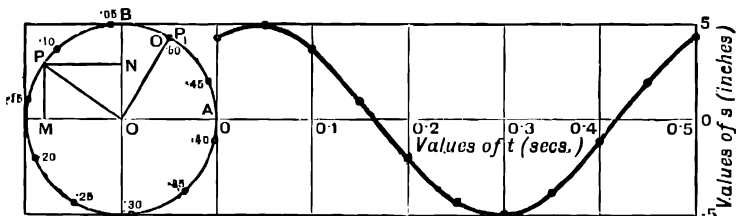

FIG. 61.

Draw a circle of radius to represent 5" on some suitable scale. Draw the horizontal and vertical diameters $A'A$ and $B'B$.

Set off the angle $AOP_1 = 59^\circ$. Then OP_1 is the position of P when $t = 0$.

The crank turns through $120 \times 2\pi$ radians per minute, or 4π radians = 720° per second.

When, as in this case, the positions of P at the ends of successive seconds are too far apart to be used for plotting a curve, set off the positions of P at intervals of any convenient fraction of a second.

In this case OP moves through 36° in 0.05 sec. Starting from P_1 set off points showing the position of P at intervals of 0.05 sec. The table of chords is useful for this purpose. Set off a scale of times along OA produced, extending

from 0 to 0.5 sec., so as to show a complete oscillation of N , and plot the curve as before.

To find the equation of this curve we note that OP turns through $4\pi t$ radians in time t starting from OP_1 .

$$\begin{aligned} \therefore \text{ at time } t, \text{ angle } AOP &= AOP_1 + P_1OP \\ &= 59^\circ + 4\pi t \\ &= (12.566t + 1.030) \text{ radians} \\ \text{and } s = ON &= PM = OP \sin AOP \\ &= 5 \sin (12.566t + 1.03) \end{aligned}$$

Similarly, any equation of the form

$$s = a \sin (gt + \alpha)$$

represents the simple periodic motion of the projection of P on a vertical diameter, when

a = the radius OP = the amplitude of the motion,

g = the angular velocity of OP ;

α = the angle which OP makes with the horizontal diameter when $t = 0$.

The ratio which the angle $gt = P_1OP$ in Fig. 61, through which OP has turned at any instant since $t = 0$, bears to the angle 2π , through which it turns in a whole revolution, is called the **phase** of the vibration when the time = t seconds.

The angle BOP_1 between the revolving arm OP , at the instant when $t = 0$, and the axis, along which the periodic motion takes place, is called the **epoch** of the vibration.

EXAMPLES.—XI.III.

Plot the following curves between $t = 0$ and $t = 2\pi$:—

1. $y = 2 \sin t$.

2. $y = \frac{1}{2} \sin 2t$.

3. $y = \frac{1}{2} \sin 3t$.

4. $y = \frac{1}{2} \sin 4t$.

5. $y = \frac{1}{2} \sin 5t$.

6. A crank, 1 ft. long, starts in a horizontal position, and rotates in a counter-clockwise direction in a vertical plane at the rate of 1.2043 radians per second, so that the projection of the moving end of the crank on a vertical line oscillates with a simple periodic motion. Construct a curve to show the distance of the projection from the centre of its path at any time. Write down the equation to this curve.

7. Construct the corresponding curve when the crank in the last example starts in the same position, and rotates at the same rate in a clockwise direction. Write down the equation to this curve.

8. A crank, 6 ins. long, starts at an angle of 45° with the horizontal, and turns through 30° per second in a counter-clockwise direction in a vertical plane. Construct a curve to represent the simple periodic motion of the projection of the free end of the crank on a vertical line. Write down the equation of this curve. Construct the corresponding curve when the same crank starts in the same position, and rotates in a clockwise direction. Write down its equation.

9. A crank 9 ins. long starts in a position making an angle of 13° with the axis of x , and rotates in a counter-clockwise direction at the rate of 10 revolutions a minute. Draw a curve to show the motion of the projection of the end of the crank on Oy . Write down the equation of this curve.

10. A straight line OP of length 1.8 ins. starts in a position such that $xOP = -42^\circ$, and rotates in a counter-clockwise direction about O at the rate of 1200 revolutions per minute. M is the projection of P on Ox . Construct a curve to show the value s of OM at any time t , and write down the equation connecting s and t .

Plot curves to represent the following motions :—

11. $s = 2.5 \sin (1.117t - 0.7156)$.

12. $s = 4.2 \sin (1.2217 - 0.4363t)$.

13. $s = 2.5 \sin (1.885 - 1.4661t)$.

14. $s = 1.5 \sin (200t + 1.5)$.

15. $s = 1.5 \cos \left(\frac{\pi}{36}t + \frac{\pi}{12} \right)$.

16. Plot the curve

$$y = 3 \sin (2\pi ft + 1'5708)$$

where $f = 10$, and t is measured in seconds.

17. Plot the curve

$$y = A \sin (qx + g)$$

where $A = 2'4$, $q = 0'7854$, $g = -1'3090$.

18. Plot $s = A \sin (2\pi ft + c)$, for the case when $A = 5'6$, $c = -0'7$, and $f = 140$, so as to show a complete period.

19. If i is the value of an alternating electric current at time t and $i = 3'5 \sin 800t$, plot a curve to show the value of i at any time throughout a complete period.

20. V is the voltage in a certain circuit at time t and $V = RA \sin qt$. Plot a curve to show the value of V at any time throughout a complete oscillation if $R = 0'25$, $A = 3'1$, $q = 2000\pi$.

75. $y = ac^{bx} \sin (cx + d)$.

Consider the case

$$y = e^{-\frac{1}{2}x} \sin 2x$$

The curve $y = e^{-\frac{1}{2}x}$ is plotted in Fig. 55, and $y = \sin 2x$ in Fig. 58.

Plot these two curves together with the same axes, measuring x in radians for the curve $y = \sin 2x$ (Fig. 62, a and b).

For various values of x multiply the corresponding ordinates together, thus getting ordinates of the curve

$$y = e^{-\frac{1}{2}x} \sin 2x$$

This is the curve c in Fig. 62.

Note that this is a wave curve in which the amplitude of the successive waves gets smaller and smaller, while the wave length remains the same.

If y represents distance moved in time x , curves of this type may be used to represent such cases as the oscillations of a stiff spring, the damped

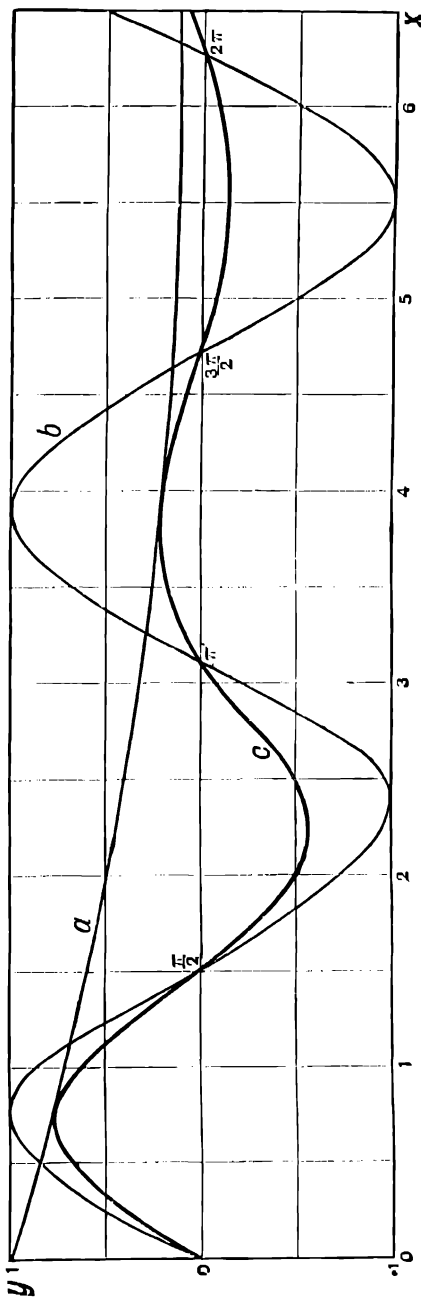

FIG. 62.

oscillations of a galvanometer needle, or the oscillations of a disc suspended by a wire in a liquid, such as is used to compare the viscosities of different liquids.

If y represents the electric current passing at time x , curves of this type may be used to represent the oscillatory discharge of a condenser.

In the case of a damped oscillation the curve (b) represents the oscillation which would take place if there were no friction, while the curve (a) represents the effect of the resistance, such as the stiffness of the spring or the viscosity of the air or liquid in which the oscillation takes place.

In the oscillation represented by $y = ae^{-kt} \sin(ct + d)$ the quantity k may be taken as a measure of the effect of the resistance, and is called the **logarithmic decrement** of the oscillation.

EXAMPLES. --XLIV.

1. Plot the curve

$$y = e^{-\frac{1}{2}x} \sin 6x$$

between $x = 0$ and $x = 4\pi$.

2. Plot the curve

$$s = 20e^{-0.6t} \sin \frac{2\pi}{2.3} t$$

between $t = 0$ and $t = 4\pi$.

3. s is the displacement of the end of a stiff spring from its position of equilibrium at time t seconds.

$$s = ae^{-bt} \sin \frac{2\pi}{T_1} t$$

a is the amplitude which the oscillation would have if there were no friction; T_1 is the period; b represents the effect of the stiffness of the spring. If $a = 10$, $T_1 = 0.9$, $b = 0.75$, plot a curve to show the value of s at any time during the first four complete oscillations.

4. The oscillatory discharge of a certain condenser through a circuit containing resistance and self-induction is given by the equation

$$v = 1414e^{-10^4 t} \sin(10,000t + 0.7854)$$

Plot a curve to show the value of the potential v at any time between $t = 0$ and $t = 10^{-2}$ seconds.

76. Curves representing Compound Periodic Oscillations.—An equation of the form $y = a \sin(ct + d)$ represents the simplest form of periodic oscillation, such as the small oscillation of a pendulum.

We often meet with more complicated oscillations, which may be represented by equations of the form

$$y = a_1 \sin(ct + d_1) + a_2 \sin(2ct + d_2) + a_3 \sin(3ct + d_3) + \dots$$

The note of a musical instrument, for example, consists of a fundamental tone represented by the first term on the right-hand side of the equation, and its overtones represented by terms such as the second and third. The second and third terms represent the first and second harmonics respectively, and so on.

In the study of alternating electric currents, also we meet with functions of the form

$$i = a_1 \sin(\phi t - \theta_1) + a_2 \sin(3\phi t - \theta_2) + a_3 \sin(5\phi t - \theta_3)$$

In problems on valve motion we usually meet with oscillations composed of the fundamental and the first harmonic, such as

$$y = 3 \sin (\theta + 36^\circ) + 0.3 \sin (2\theta + 90^\circ)$$

EXAMPLE.—Plot the curve

$$y = 2 \sin t + \frac{1}{2} \sin 3t$$

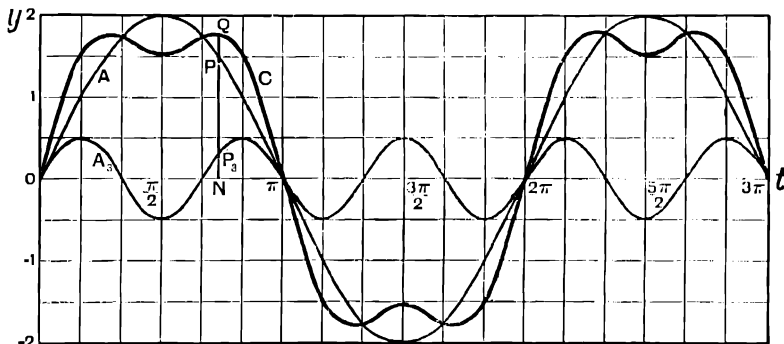

FIG. 63.

Plot the curves $y = 2 \sin t$, (A), and $y = \frac{1}{2} \sin 3t$, (A_2). A represents the fundamental, and A_2 the second harmonic.

The required curve C is obtained from these two curves by adding together the two ordinates which correspond to any given value of x .

E.g. if PN and P_2N be the ordinates of the fundamental, and of the second harmonic corresponding to any given value ON of x , then the ordinate QN of the required curve is equal to $NP + NP_2$. The addition should be carried out mechanically by means of dividers, and not arithmetically. From P mark off PQ equal to NP_2 , and so on.

We thus obtain the curve C representing the combination of the fundamental and the second harmonic.

The curve C might also have been obtained by direct calculation of each value of y , but it is more instructive to plot the harmonics separately, as above.

EXAMPLES.—XLV.

Plot the following curves from $t = 0$ to $t = 2\pi$:—

1. $y = 2 \sin t + \frac{1}{2} \sin 2t$.
2. $y = 2 \sin t + \frac{1}{2} \sin 4t$.
3. $y = 2 \sin t + \frac{1}{2} \sin 5t$.
4. $y = 2 \sin t + \frac{1}{2} \sin 2t + \frac{1}{3} \sin 3t$.
5. Plot $y = \sin qt + \frac{1}{2} \sin 5qt$ for the case $q = 600$, from $t = 0$ to $t = \frac{2\pi}{q}$.

Plot the following from $t = 0$ to $t = 2\pi$:—

6. $y = 2 \sin (t + 1.0123) + \frac{1}{2} \sin 3t$.
7. $y = 2 \sin (t - 0.6807) + \frac{1}{2} \sin 4t$.
8. $y = 2 \sin (t + 0.4014) + \frac{1}{2} \sin (2t - 0.5061)$.

9. Plot $y = \frac{1}{\sqrt{2}} \sin x + \frac{1}{\sqrt{2}} \cos x$ by constructing the two curves separately and

adding the ordinates ; also plot the curve $y = \sin \left(x + \frac{\pi}{4} \right)$ and verify the formula for $\sin (A + B)$ by showing that the two curves are the same.

10. Plot $y = 0.342 \sin x - 0.940 \cos x$, and verify the formula for $\sin(A - B)$ by showing that this is the same as

$$y = \sin(x - 70^\circ)$$

11. The value of an alternating electric current i amps. is given at time t seconds by the equation

$$i = 50 \sin 600t + 20 \sin 1800t$$

Plot a curve to show the connection between i and t . Take t on a large scale and plot to show two complete alternations.

12. The voltage V in an alternating current circuit at time t is given by

$$V = RA \sin qt + LAq \cos qt$$

Plot a curve to show V as a function of t for two complete periods, having given that

$$R = 0.5, A = 5, q = 1000, L = 0.0005$$

13. If x is the distance of a piston from a fixed point on its path at time t ,

$$x = r \sin qt + \frac{r^2}{4l} \cos 2qt - \frac{r^2}{4l}$$

where q = angular velocity of crank, r = length of crank, l = length of connecting-rod. Plot a curve to show x as a function of t when $r = \frac{1}{2}$, $l = 3$, $q = 2\pi$.

14. OAB is a crank capable of revolving in a counter-clockwise direction in the vertical plane OAB , about an axis through O . It is bent at right angles at A . OA is 3 ins. long, AB is 2 ins. long. OY is a fixed vertical straight line; M and N are the projections of A and B on OY . The crank starts in a position such that OA makes an angle 45° with OY , and AB points towards OY , and moves towards OY at the rate of 120 revolutions per minute. Let $ON = y$; plot a curve to show the value of y for any value of t from $t = 0$ to $t = 1$ sec. Write down the equation, giving y in terms of t .

15. The force F on the piston of an engine, when the crank makes an angle θ with a fixed direction, is given by

$$F = M\omega^2 r \{ \cos \theta + 0.29 \cos 2\theta - 0.006 \cos 4\theta \}$$

for the case where the connecting-rod is three and a half times as long as the crank. Plot a curve, as accurately as your scale will allow, to show the value of F for any value of θ from $\theta = 0$ to $\theta = 360^\circ$, taking $M = 40$, $\omega = 6\pi$, $r = 0.5$.

(Electrician, Feb. 13, 1903, p. 670.)

77. **Graphic Solution of Equations.**—To solve an equation, we require to find the values of x which make a given function of x equal to zero. If we plot a curve in which the ordinates are the values of this function for various values of x , the points where this curve crosses the axis of x give the required values of x for which $y = 0$.

EXAMPLE (1).—Solve the equation

$$x^2 - 4.31x + 3.93 = 0$$

Let $y = x^2 - 4.31x + 3.93$.

Calculate the values of y for various values of x , such as 0, 1, 2, etc., for which the calculations can be rapidly made.

We find

$$\begin{aligned} \text{when } x = 0, y &= 3.93 \\ \text{,, } x = 1, y &= 0.62 \\ \text{,, } x = 2, y &= -0.69 \\ \text{,, } x = 3, y &= 0 \end{aligned}$$

Thus one root of the equation has been found by trial.

If we plot a curve representing y as a function of x , this curve is above the axis of x at $x = 1$, and below it at $x = 2$, therefore it must cross the axis of x between $x = 1$ and $x = 2$.

When $x = 1.5$, we find $y = -0.285$.

The student should plot the curve.

Plot the values of y for the values $x = 1$, $x = 1.5$, and $x = 2$. The curve obtained crosses the axis of x at the point $x = 1.3$. By trial we find that the value $x = 1.3$ is a root of the equation. Thus the required roots are 3 and 1.3.

EXAMPLE (2).—To find a value of x between 0 and 2, which satisfies the equation

$$x^3 + 2x^2 - 3.26x - 0.3127 = 0$$

Let y denote the expression on the left-hand side of this equation.

We find by calculation

$$\begin{aligned} \text{when } x = 0, y &= -0.3127 \\ \text{,, } x = 1, y &= -0.5727 \\ \text{,, } x = 2, y &= +9.1673 \end{aligned}$$

therefore, if we plot a curve representing y as a function of x , this curve is below the axis of x at $x = 1$, and above the axis of x at $x = 2$, and therefore it must cross the axis of x between $x = 1$ and $x = 2$.

For $x = 1.5$ we find $y = 2.562$, therefore a root lies between $x = 1$ and $x = 1.5$.

Plotting the points whose co-ordinates have been calculated, we get the curve, Fig. 64.

This crosses the axis of x between $x = 1.1$ and $x = 1.2$.

By calculation we find

$$\begin{aligned} \text{when } x = 1.1, y &= -0.1477 \\ \text{,, } x = 1.2, y &= +0.3833 \end{aligned}$$

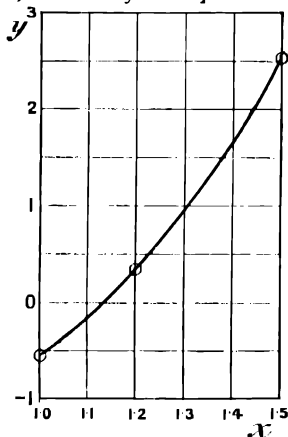

FIG. 64.

Plotting these points on a large scale, and joining by a straight line, we see that 1.13 is approximately a value of x , for which $y = 0$.

By calculation, when $x = 1.13$, $y = 0$, to 5 places of decimals.

To secure still greater accuracy, if necessary, we might calculate y for the values $x = 1.12$, and $x = 1.14$, and plot on a still larger scale; and so on.

EXAMPLE (3).—Solve the simultaneous equations

$$\begin{aligned} y &= x^3 - 0.6x^2 + 0.2x - 1.4 \\ y &= 1 + x - 0.4x^2 \end{aligned}$$

Here we require to find a pair of values of x and y to satisfy both these equations simultaneously. If we plot the curves represented by the two equations, the points of intersection lie on both curves, and therefore their co-ordinates satisfy both equations, and give the required roots.

$$\begin{aligned} \text{Let } y_1 &= x^3 - 0.6x^2 + 0.2x - 1.4 \\ y_2 &= -0.4x^2 + x + 1 \end{aligned}$$

Then by calculation we find the following pairs of corresponding values :—

x .	y_1 .	y_2 .
0	-1.4	1.0
1	-0.8	1.6
2	4.6	1.4
-1	-3.2	-0.4
-2	-12.2	-2.6

On plotting these points we see that the curves cross between $x = 1$, and $x = 2$, and from their general shape this appears to be their only point of intersection.

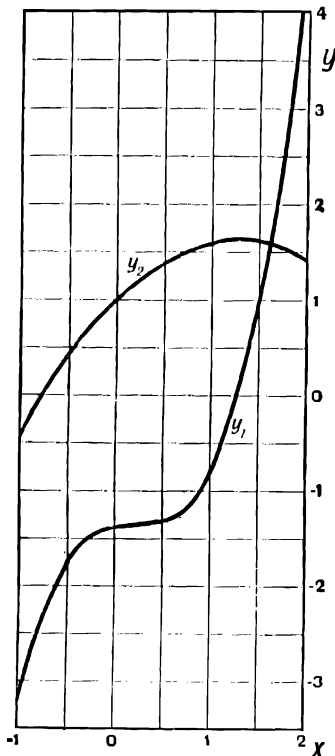

FIG. 65.

Accordingly we calculate the following values of y_1 and y_2 in the neighbourhood of the point of intersection :—

x .	y_1 .	y_2 .
1.5	0.925	1.6
1.6	1.48	1.58
1.7	2.019	1.544

These curves evidently cross between $x = 1.6$ and $x = 1.7$.

Plotting these points on a larger scale, we see that the curves cross, and therefore the equations are satisfied, for the values $x = 1.62$, $y = 1.57$.

EXAMPLE (4).—To find the values of x between 0 and 3.1416 which satisfy the equation $e^x \sin x = 1$.

The most instructive method is the following :—

If $e^x \sin x = 1$, we have $\sin x = e^{-x}$.

Plot the curves $y = \sin x$ and $y = e^{-x}$. Then at the points where these curves

cross, $\sin x$ and e^{-x} are equal, and the required values of x are therefore the abscissae of these points of intersection.

NOTE.— x must be measured in radians.

$y = \sin x.$		$y = e^{-x}.$	
$x.$	$y.$	$x.$	$y.$
0	0	0	1
0.7854	0.7071	1	0.3679
1.5708	1	2	0.1353
3.1416	0	3	0.0498

On plotting these values we see that the two curves cross in the neighbourhood of $x = 0.6$ and $x = 3$.

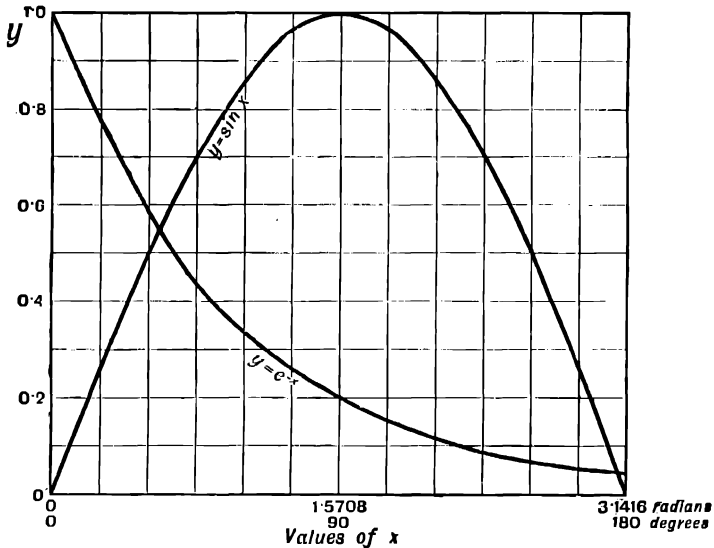

FIG. 66.

Calculating the values more accurately in the neighbourhood of these points, we find

$y = \sin x.$		$y = e^{-x}.$	
$x.$	$y.$	$x.$	$y.$
$27^\circ = 0.4712$	0.4540	0.4712	0.6242
$30^\circ = 0.5236$	0.5000	0.5236	0.5916
$33^\circ = 0.5760$	0.5446	0.5760	0.5622
$36^\circ = 0.6283$	0.5878	0.6283	0.5333

and

x .	y .	x .	y .
$360^\circ = 3\cdot1416$	0	$3\cdot1416$	$0\cdot0432$
$354^\circ = 3\cdot0369$	$0\cdot1045$	3	$0\cdot0498$
$357^\circ = 3\cdot0892$	$0\cdot0523$	—	—
$358^\circ = 3\cdot1067$	$0\cdot0349$	—	—

Plotting the corresponding portions of the two curves on a large scale, we find that, at the points where they cross,

$$x = 0\cdot5885 \text{ and } 3\cdot0965$$

The student should verify this by plotting the above values himself.

These are, therefore, the required roots of the equation

$$e^x \sin x = 1$$

EXAMPLES.—XLVI.

Solve the following equations by the graphic method :—

1. $x^2 + 0\cdot8x - 2\cdot73 = 0$.

2. $x^2 - 0\cdot83x + 0\cdot1612 = 0$.

3. $x^3 - x - 6 = 0$.

4. $x^3 - 6x^2 + 11x - 6 = 0$.

5. $x^3 - 0\cdot7x^2 - 0\cdot6x + 2\cdot6 = 0$.

6. $x^3 + x^4 - 6x^3 - 13x^2 - 13x - 6 = 0$.

7. $2x^4 - 7\cdot6x^3 - 4\cdot06x^2 + 4\cdot16x + 9\cdot84 = 0$.

8. $e^{2x} = 7$.

9. $e^{-12x} = 2\cdot5$.

10. $x \log_{10} x = 1$.

Find values of x between 0 and 5 to satisfy each of the following equations :—

11. $2x^{1\cdot3} + x - 3e^{0\cdot275x} - 2 = 0$.

12. $3\cdot1x^{3\cdot5} - 1\cdot9x^{2\cdot0} - x - 8 + 4e^{0\cdot195x} = 0$.

13. $2\cdot5e^{0\cdot22x} \cos x - 1\cdot31x^{2\cdot3} \sin(0\cdot6x) + 0\cdot788 = 0$.

14. $e^{1\cdot6x} \tan 0\cdot3x - 2\cdot6 \cos 1\cdot8x - 5x^{1\cdot3} + 2\cdot8343 = 0$.

15. The equation $x \tan x = a$ occurs in finding the proper tones of the vibration of a loaded string.

Find a value of x between 0 and $\frac{\pi}{2}$ to satisfy this equation (1) when $a = 0\cdot1$,

(2) when $a = 1$, (3) when $a = 10$.

16. In calculating the strength of a long column fixed at one end and held by a horizontal force at the other, we require to solve the equation $\tan x = x$. Find the value of x between π and $\frac{3\pi}{2}$ which satisfies this equation.

17. Find a value of t to satisfy the equation

$$\log_e \frac{t}{274} + \frac{7\cdot07}{t} - 0\cdot695 = 1\cdot78$$

CHAPTER VIII

DETERMINATION OF THE LAWS FOLLOWED BY THE RESULTS OF EXPERIMENTS

78. IN most quantitative experiments we have two varying quantities, such as the pressure and volume of a certain quantity of gas, or the length and temperature of a metal bar. We take various values of one of these quantities, and observe the corresponding values of the other. If we plot these two sets of values on squared paper, we usually find, if they really depend on each other, that the points obtained lie approximately on some continuous curve. We often wish to find a formula connecting the two quantities, so that when one is known we may be able to calculate the other. To do this we must find the equation of the curve.

79. Straight line laws:—

We have seen that any straight line is represented by an equation of the first degree, $y = mx + c$, and that m denotes the slope of the line, and c the intercept on the axis of x .

Thus if the observed quantities give points lying on a straight line, we can at once find the equation connecting them, as in the example on p. 90.

EXAMPLE.—A restaurant keeper finds that if he has G guests a day his total daily expenditure is E pounds, and his total daily receipts are R pounds. The following numbers are averages obtained from the books:—

G.	E.	R.
210	16·7	15·8
270	19·4	21·2
320	21·6	26·4
360	23·4	29·8

Find the simple algebraical laws which seem to connect E and R with the number of guests G .
(Board of Education Examination, 1901.)

Plotting these values, we get the straight lines **AB** and **CD** (Fig. 67).

Let $R = m_1 G + c_1$, be the equation of the line **AB**. To find m_1 and c_1 take two points, **A** and **B**, on the line at considerable distance apart.

Co-ordinates of **A** are (210, 15·7)
 „ „ **B** are (350, 29)

Since these points are on the straight line

$$R = m_1 G + c_1$$

their co-ordinates satisfy this equation, and we have

$$15.7 = 210m_1 + c_1$$

$$29 = 350m_1 + c_1$$

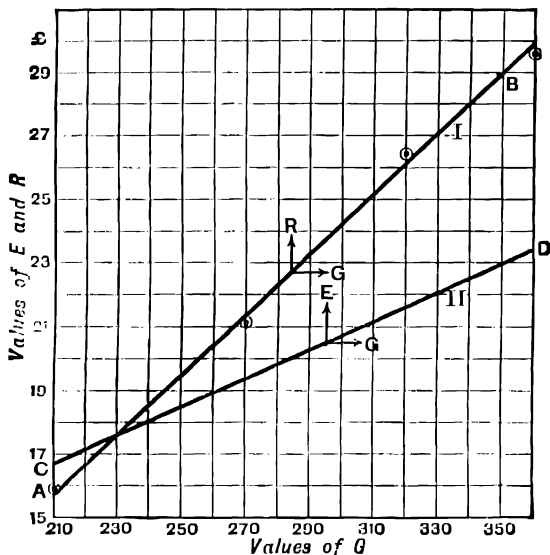

FIG. 67.

Solving these as simultaneous equations for m_1 and c_1 , we get

$$m_1 = 0.095; \quad c_1 = -4.25$$

∴ the required law connecting R and G is

$$R = 0.095G - 4.25$$

Similarly, if $E = m_2G + c_2$ is the equation of the straight line CD, we take points C and D on the line, and substitute their co-ordinates in the equation,

$$\text{we get } 16.7 = 210m_2 + c_2$$

$$23.4 = 360m_2 + c_2$$

we get $m_2 = 0.0447$, $c_2 = 7.32$, and $E = 0.0447G + 7.32$.

EXAMPLES.—XLVII.

In the following examples the expression "the law connecting y and x " is understood to mean a formula arranged so that y can be readily calculated when x is known, such as $y = mx + c$, *i.e.* a formula giving y explicitly in terms of x .

Find the law connecting y and x when the following corresponding values are given:—

1.

x	10	25	54	72
y	17	47	105	141

2.

x	12	15.3	17.8	19
y	24.4	29	32.6	34.2

3.

x	50	62.4	80.5	97
y	7.5	6.5	5.05	3.75

4. L is the latent heat of steam at temperature θ° C. Find a simple formula giving L in terms of θ .

θ	75	90	100	115	125
L	554	544	536	526	519

5. II is the total heat of a pound of steam at temperature θ° C. Find a formula giving II in terms of θ .

θ	65	85	100	110	120
II	626.3	632.4	637.0	640.1	643.1

6. V c.c. is the volume of a certain quantity of gas at temperature t° C, the pressure being constant. Find the law connecting V and t .

t	27	33	40	55	68
V	109.9	112.0	114.7	120.1	125

7. l ft. is the length of an iron bar under a stress of W tons. Find the law connecting l and W .

W	0	1	1.8	3.2	4.3	6
l	10	10.005	10.010	10.0175	10.0225	10.0325

8. V is the volume of a certain quantity of mercury at temperature $\theta^\circ \text{C}$. Find the law connecting V and θ .

$\theta^\circ \text{C}$.	18	36	60	72	90
$V \text{ cc}$	100.32	100.65	101.07	101.30	101.61

9. The following table gives the specific heat s of water at temperature $\theta^\circ \text{C}$:—

θ	0°	2°	4°	6°	8°
s	1.00664	1.00543	1.00435	1.00331	1.00233

Find an approximately correct simple algebraic law connecting s and θ .

10. S is the specific heat of mercury at temperature $t^\circ \text{C}$. Find the law connecting S and t .

t	79°	100°	119°	130°
S	0.0325392	0.0323460	0.0321712	0.0320700

11. S is the weight of sodium nitrate dissolved by 100 grms. of water at temperature $t^\circ \text{C}$. Find the law connecting S and t .

S	68.8	72.9	87.5	102
t	-6	0	20	40

12. S is the weight of potassium bromide, which will dissolve in 100 grms. of water at temperature $t^\circ \text{C}$.

t	0	20	40	60	80
S	53.4	64.6	74.6	84.7	93.5

13. The following table gives the amount $\text{£}A$ of a certain sum of money at simple interest for n years. Find a simple algebraical law connecting A and n , and by means of this law calculate the amount in 7 years.

n	2	5	8	10
A	318.6	354	389.4	413

14. The following is taken from the price-list of Marshall's horizontal engines. H denotes the horse-power of an engine, and P its price in pounds.

H	6½	10	14	19	21	26	33	40	48	56
P	31	37	46·5	57·5	67	83	104	124	145	162

Find a simple algebraic law connecting P and H . Also find an approximate law connecting the cost C per unit $H.P.$, and the total $H.P.$ of an engine; and plot a curve to show the value of C for any value of H from 6½ to 56.

15. The following table is taken from the price list of Tangye's horizontal air-pump condensers.

d is the diameter in inches, P is the price in pounds.

d	6	7	8	9	10	12	14	16	18	20	22	24	26	30
P	25	27	30	33	35	40	50	55	60	70	75	85	90	100

What would you expect the price to be for a diameter of 28 ins. ? Find a simple approximately correct algebraic law connecting the price and the diameter. Test the accuracy of your result by calculating from it the price for a diameter of 16 ins., and comparing with the table.

16. The following are corresponding values of the speed and induced volts in an arc light dynamo. Find the law connecting the volts, and the revolutions per minute.

Revolutions per minute n	200	320	495	621	744
Volts induced v	165	270	410	525	625

17. In the following results of Willans' engine trials, W is the weight of steam per hour; I the indicated horse-power. For each set of results find an approximate linear law connecting W and I .

I	31·63	27·24	21·87	16·11	11·50	9·06
W	811·80	686·1	583·6	465·26	345·4	266·22

18.

I	40·14	33·25	25·61	18·69	10·81
W	671·44	564·2	443·22	336·13	219·1

19.

I	33'19	27'11	22'09	11'86	11'66
W	492'12	411'47	349'73	216'50	212'60

20. The following table is obtained from the results of experiments to find how the pull exerted at the draw-bar by an electric locomotive depends upon the current. P is the pull in pounds, A the current in amperes.

P	400	880	1370	1600	2080	2400
A	65	86	106	116	137	150

Find the current required for a pull of 2000 lbs. Find a simple approximately correct algebraic formula giving A for any value of P within the limits of the experiments.

21. The following are corresponding values of the torque and current in the armature of an Edison Bipolar Dynamo.

Torque inch-lbs.	76	145	290	380	500	575
Current amperes	11	20	40	52	68	78

Find a simple algebraic law connecting the torque and the current in the armature.

22. P is the pull required to lift a weight W by means of a differential pulley block. Find the law connecting P and W.

W	56	112	168	224	340
P	10	17	24	28	42

If h is the distance moved by P to lift W 1 ft. the efficiency is $\frac{W}{Ph}$. Find the law connecting the efficiency and the weight, having given $h = 27.2$ ft.

80. Other Forms reduced to Straight Line Laws.—If we have a number of corresponding values of x and y which are connected by a law of the form $y = a + bx^2$, then, if we plot x and y , we shall get a parabola which is not easily identified. If, however, we plot y and x^2 , we get a straight line, because the equation $y = a + b(x^2)$ is of the first degree in the two variables y and x^2 .

EXAMPLE.—The following values of x and y are supposed to follow a law of the form $y = a + bx^2$. Test this, and find the values of the constants.

x	19	25	31	38	44
y	1900	3230	4900	7330	9780

Calculate the values of x^2 , and then plot y and x^2 .

x^2	361	625	961	1444	1936
-------	-----	-----	-----	------	------

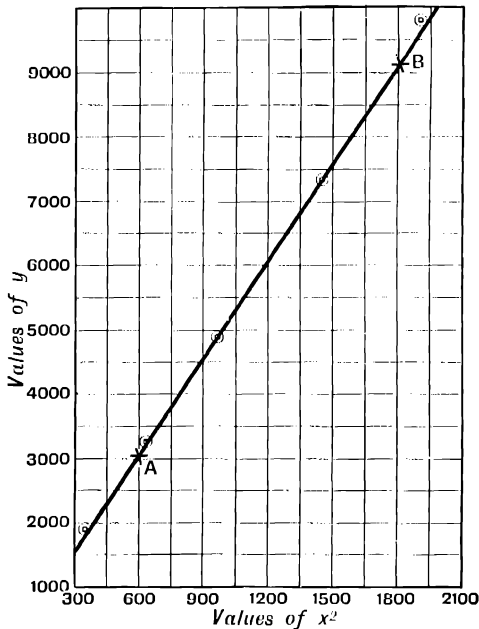

FIG. 68.

The result is the straight line AB, Fig. 68. To find the values of a and b , take any two points A and B on the straight line, and substitute the co-ordinates of the points A and B in the equation $y = a + bx^2$.

We get two simultaneous equations to find a and b .

$$\begin{aligned} 3045 &= a + 600b \\ 9155 &= a + 1800b \\ \therefore b &= 5.092; a = -10 \end{aligned}$$

and the required law is

$$y = 5.09x^2 - 10$$

81. Similarly, many other algebraical laws may be represented by straight line laws by plotting suitable powers or products of the variables.

E.g. if $y = axy + b$, we get a straight line by plotting y and xy , because the equation is of the first degree in y and xy .

If $xy = ax + by$ we have, dividing by x , $y = a + b\left(\frac{y}{x}\right)$. This is of the first degree in y and $\frac{y}{x}$, and therefore we get a straight line by plotting these quantities.

EXAMPLE (1).—The following values of x and y are supposed to follow a law of the form $y = bx + c$. Test this, and find the law.

x	3	4.6	5.2	6.9
y	0.75	0.416	0.357	0.253

Calculating the values of xy , we get

xy	2.25	1.914	1.856	1.749
------	------	-------	-------	-------

Plotting y and xy we get a straight line, and therefore the law is of the above form. The student should draw the figure for himself. Taking two points on the line, and substituting their co-ordinates in the equation $y = bx + c$, we obtain two simultaneous equations to find b and c .

Solving these we get $b = 1$, $c = -1.5$, and the law connecting xy and x is

$$y = xy - 1.5$$

EXAMPLE (2).—The following are results of Mrs. Ayrtton's experiments to find the relation between the potential difference V and the current A in the electric arc.

Length of arc = 2 mm.

A amperes	1.96	2.46	2.97	3.45	3.96	4.97	5.97	6.97	7.97	9.0
V volts	50.25	48.7	47.9	47.5	46.8	45.7	45.0	44.0	43.6	43.5
W = VA watts calculated	98.49	118.7	147.7	163.9	185.3	227.2	268.7	306.7	346.7	391.3

It was required to find an equation connecting V and A . On plotting V and A a curve was obtained whose equation was not at once evident.

When the power in watts, W equal to VA , and the amperes were plotted the result was a straight line (Fig. 69).

The calculated values of W are given in the third line above.

Let the equation to this straight line be

$$W = aA + b. \dots \dots \dots I$$

By measurement from the figure we find,

$$\begin{aligned} \text{when } A = 1, W &= 63 \\ \therefore A = 10, W &= 434 \end{aligned}$$

∴ substituting in I,

$$\begin{aligned} 63 &= a + b \\ 434 &= 10a + b \end{aligned}$$

Solving we get $a = 41.22$, $b = 21.8$.

$$\therefore W = VA = 41.2A + 21.8$$

$$\therefore V = 41.2 + \frac{21.8}{A}$$

This is the law connecting V and A, and is the equation to the curve II shown in the figure.

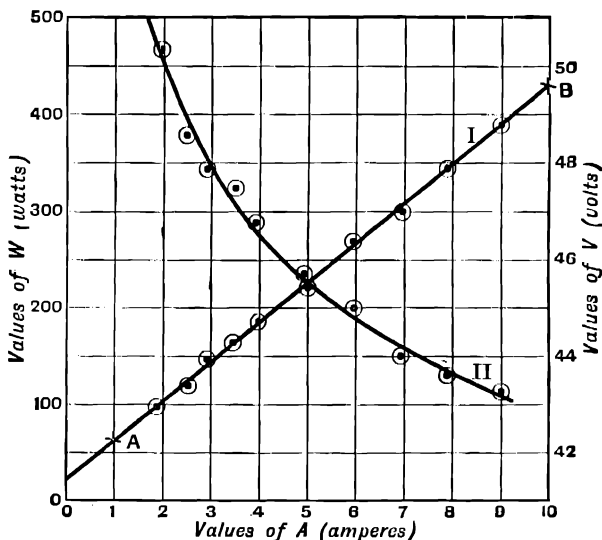

FIG. 69.

It will be seen that some of the points are above and some below the line. After plotting the results of any experiment in this way, the distance of the plotted points above or below the curve enables us to form an estimate of the most probable degree of error in each reading in so far as it is not due to some permanent cause such as a defect in the apparatus, to see which are the best results, and what is the most probable average degree of accuracy in the whole series of observations.

It should be remembered that, in a case like the curve II (Fig. 69), where the vertical scale does not begin at zero, the divergence of the various readings from the curve must be reckoned on the whole value of the quantity represented by the ordinate in estimating the accuracy of the experiments, and not only on the part actually shown in the figure.

EXAMPLES.—XLVIII.

In examples I to II, y and x are connected by one or other of the laws $y = a + bx^2$, $y = a + bxy$, $xy = ax + by$.

Find the law and the values of the constants in each case.

1.

x	39.5	57.6	70.8	88.5
y	333	685	1061	1587

2.

x	19	25	31	38	44
y	1908	3228	4908	7323	9783

3.

x	2.05	4.31	5.62	7.84
y	2.8	1.43	1.12	0.816

4.

x	1.3	3.4	6.2	8.3	12.2
y	0.56	0.91	1.11	1.18	1.27

5.

x	6.1	9.3	13.5	17.6
y	44.4	40.96	33.75	25.3

6.

x	0.45	0.97	1.3	2.5
y	6.48	7.9	9.17	22.4

7.

x	3	4.6	5.2	6.9	7.1
y	0.75	0.416	0.357	0.253	0.246

8.

x	31	47	63	85
y	8.35	9.41	10.1	10.7

9.

x	2.1	5.4	6.7	9.3	10.2
y	1.825	0.885	0.832	0.778	0.767

10.

x	6	6.93	7.48	8.66	9.22
y	7.5	11.5	13.8	20.5	23.5

11.

x	65.5	76.2	82.7	92.6	97.7
y	55	63	67.7	81	87

12. The following table gives the horse-power required to drive a certain vessel at a speed of V knots :—

H.P.	290	560	1144	1810	2300
V	5	7	9	11	12

It is supposed that the H.P. is connected with the speed by a law of the form $H.P. = kV^3 + C$ where k and C are constants. Test this, and find the approximate values of the constants.

13. The following are results of Westinghouse and Galton's experiments on the friction of steel rails on steel tyres.

Velocity in miles per hour = V . . .	25	38	45	50
Coefficient of friction = μ	0.080	0.051	0.047	0.040

Find the law connecting V and μ .

14. R is the resistance in pounds per ton to the motion of a train at V miles per hour. Find the law connecting R and V.

V	10	20	30	40	50
R	7	9.1	14.5	20	29

15. The following is taken from the price-list of Clyburn's adjustable spanners. S is the size, and P the price in shillings.

S inches	$\frac{1}{2}$	$\frac{3}{4}$	1	$1\frac{1}{4}$	$1\frac{1}{2}$	$1\frac{3}{4}$	2	$2\frac{1}{4}$	$2\frac{1}{2}$
P	3.5	4.5	6	7.5	9.5	12	15	18	21

Find an approximately correct algebraical law connecting P and S.

16. The following is taken from the price-list of Tangye's gun-metal plug-taps S is the size in inches, and P the price.

S	$\frac{1}{4}$	$\frac{1}{2}$	$\frac{3}{4}$	1	$1\frac{1}{4}$	$1\frac{1}{2}$	2	
P	2	2.75	3.5	5	7.5	10.75	13.75	22.5

Find an approximately correct algebraical law connecting P and S.

17. The average power sent out by an electrical company is P. x pence is the charge per horse-power hour which will just cover the cost of this. Find a simple algebraical law connecting x and P.

P	1000	750	500	250	100
x	1.1	1.3	1.5	2.4	4.9

18. The data in examples 18, 19, 20, are results of Mrs. Ayrton's experiments on the resistance of the electric arc. As in the worked example above, find for each case the formula, giving V in terms of A.

Length of arc = 3 mm.

A (amps.)	1.96	2.46	2.97	3.45	3.96	4.97	5.97	6.97	7.97
V (volts.)	67.0	62.75	59.75	58.5	56.0	53.5	52.0	51.4	50.6

19. Length of arc = 4 mm.

A	2'46	2'97	3'45	3'96	4'97	5'97	6'97	7'97
V	67'7	65'0	63'0	61'0	58'25	56'25	55'1	54'3

20. Length of arc = 2 mm.

A	1'96	2'46	2'97	3'45	3'96	4'97	5'97	6'97	7'97
V	60'0	55'75	53'5	52'0	51'2	49'8	49'0	48'1	47'4

21. A hydrometer is found to give the following readings r when immersed in liquids of density D . Find the law connecting D and r for this hydrometer, and from this law draw the calibration curve showing D as ordinate for any value of r between 10 and 40 as abscissa.

D	0'91	0'90	0'88	0'86
r	24'3	26	29'7	33'5

22. r is the reading of a hydrometer intended for measuring the densities of liquids heavier than water, when immersed in a liquid of known density D . Find a formula to give D for any value of r from $r = 0$ to $r = 50$. What is the density of a liquid for which the reading is 30.

r	0	13'9	40	43	50
D	1	1'1	1'38	1'42	1'53

23. v is the viscosity of water at temperature θ° C. Find the law connecting v and θ .

θ	3	5	8	10
v	0'0142	0'0134	0'0122	0'0116

24. E is the thermo-electric E.M.F. at the junction of copper and lead at a temperature t° C. when the other junction is at 10° C.

t	- 210	- 5	120	350
E (10 ⁻⁶ volts)	- 558	- 14	357	1122

Find a law of the form $E = at + bt^2$ connecting E and t .

82. General Formula connecting Two Variables.—It may happen that on plotting two variables y and x we get a regular curve after allowing for errors of observation, but that we can find no simple algebraic law connecting y and x .

Also we may sometimes require a more exact formula than the approximate algebraic laws found by one of the above methods.

In this case we may assume

$$y = a + bx + cx^2$$

Taking the co-ordinates of three points from the curve and substituting, we obtain three simultaneous equations to find the three constants a , b , and c .

If this law is not sufficiently exact, we may assume

$$y = a + bx + cx^2 + dx^3$$

and find the constants by substituting the co-ordinates of four points on the curve.

We shall usually find that the constants get smaller as we proceed to higher powers of x , and that the assumed law can be made as exact as we please by carrying the series to a sufficiently high power of x .

EXAMPLE.—The following table gives the modulus of torsion T of steel at various temperatures θ . Find a formula to calculate T when θ is known.

θ degrees c	0	20	40	60	80	100
T kilogrammes per sq. mm.	8290	8253	8215	8176	8136	8094

Plotting T and θ , we get a series of points which lie on a regular curve, which is nearly, but not quite, a straight line.

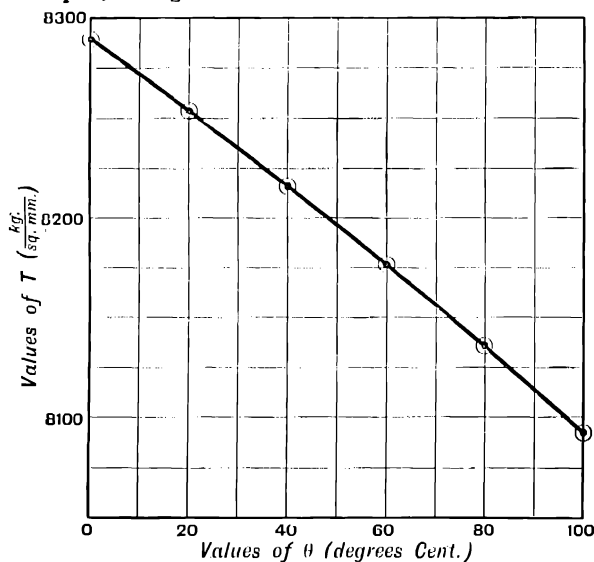

FIG. 22

The student should plot this curve for himself on a large scale.

It is evident from the figure that the variation from a straight line law is not due to errors of observation, and if we assume a straight line law the resulting formula will be less accurate than the given data.

There is nothing to lead us to assume any special form for the law connecting T and θ , and accordingly we assume

$$T = a + b\theta + c\theta^2$$

In this case, since the points representing the given data lie exactly on the curve to as high a degree of accuracy as we can plot them, we may take three of the given values for the purpose of calculating the constants.

In cases of this sort the points which are plotted from the given data will not usually lie exactly on the curve, owing to small errors of observation. The values for calculating the constants must then be taken from the curve, and not from three of the given pairs of values, because the curve has been drawn so as to compensate for small errors of observation.

Substituting the pairs of values of T and θ , for which $\theta = 0^\circ$, 60° and 100° respectively, we get

$$\begin{aligned} 8290 &= a \\ 8176 &= a + 60b + 3600c \\ 8094 &= a + 100b + 10000c \end{aligned}$$

Solving these simultaneous equations in a , b , and c , we get

$$a = 8290; \quad b = -1.81; \quad c = -0.0015$$

\therefore the required law connecting T and θ is

$$T = 8290 - 1.81\theta - 0.0015\theta^2$$

To test this formula we have, substituting

$$\begin{aligned} \theta &= 80^\circ \\ T &= 8290 - 1.81 \times 80 - 0.0015 \times 6400 \\ &= 8135.6 \end{aligned}$$

The value of t given above for $\theta = 80^\circ$ is 8136; this agrees with the formula to the degree of accuracy with which the data are given.

EXAMPLES.—XLIX.

1. Find a law of the form $y = a + bx + cx^2$, connecting the following values of y and x :—

x	1	3	5	7
y	5.5	5.9	5.5	4.3

2. θ is the melting-point of an alloy of lead and tin containing x per cent. of lead.

x	87.5	84.0	77.8	63.7	46.7	36.9
$\theta^\circ \text{C.}$	292	283	270	235	197	181

Find a formula giving the melting-point of an alloy containing any known percentage of lead from 90 to 40 per cent.

3. E is the modulus of elasticity of steel in kilogrammes per square millimetre at temperature $t^{\circ} \text{C}$.

t	0	50	100	200
E	21,483	21,364	21,212	20,458

Find a formula to calculate E in terms of t .

4. γ is the mean coefficient of expansion of mercury between temperatures 0° and $t^{\circ} \text{C}$., according to the results of Regnault's experiments.

t	0	100	150	200	250	300	360
γ	0'00018179	0'00018216	0'00018261	0'00018323	0'00018403	0'00018500	0'00018641

Find the law connecting γ and t .

83. Substitution of Linear for More Complex Laws.—We have seen that when y and x can be represented by the co-ordinates of points which lie on a regular curve, we can usually find a formula

$$y = a + bx + cx^2 + \dots$$

which will represent the law connecting y and x to any desired degree of accuracy, according to the number of terms taken.

When c is small it is sufficiently accurate for many purposes to take the law $y = a + bx$ as a sufficiently close approximation, *i.e.* when the curve is nearly straight we take a straight line as representing the curve with sufficient accuracy.

E.g. in the example, p. 140, we obtained the formula

$$T = 8290 - 1'81\theta - 0'0015\theta^2$$

So long as θ is not greater than 100, the error caused by neglecting the third term is not greater than 15, *i.e.* about 0'2 per cent. Thus we might take the linear law

$$T = 8290 - 1'81\theta$$

as an approximation to the required law.

This suggests that when the connection between y and x is given by a complicated formula, we may represent this complicated formula by a simpler linear formula to a sufficient degree of accuracy, between certain definite limiting values.

EXAMPLE.—There is a function $y = 5 \log_{10} x + 6 \sin \frac{1}{10} x + 0'084 (x - 3'5)^2$. Find a much simpler function of x , which does not differ from it in value more than 2 per cent. between $x = 3$ and $x = 6$. The angle $\frac{1}{10} x$ is in radians.

(Board of Education Examination, 1902.)

By calculation we find the following values :—

x	3	4	5	6
y	4.182	5.365	6.560	7.805

Plotting these values, we get a curve which is very nearly straight. It is seen from inspection of the curve that a straight line can be drawn so that the value of the ordinate y for the straight line differs by less than 2 per cent. from the ordinate for the curve.

Draw this straight line, and let its equation be $y = mx + c$.

The student should draw the figure for himself. We find by inspection of the line that

$$\begin{aligned} &\text{when } x = 3; y = 4.2 \\ &\text{and when } x = 6; y = 7.8 \end{aligned}$$

Substituting, we get

$$\begin{aligned} 4.2 &= 3m + c \\ 7.8 &= 6m + c \end{aligned}$$

Solving these simultaneous equations in m and c , we get

$$m = 1.2; c = 0.6$$

∴ the formula $y = 1.2x + 0.6$ may be used instead of the given formula to the required degree of accuracy.

EXAMPLES.—L.

1. Find a simple linear formula, which gives the same values of y as the formula $y = x + \sqrt{1 + x^2}$ between $x = 8$, and $x = 12$, correct to 0.2 per cent.

2. There is a function

$$y = 10e^{\frac{x}{10}} + 5 \log_{10} x + x$$

Find a simpler formula which will give the same value of y correct to less than 2 per cent. between $x = 1$ and $x = 7$.

3. Find a simpler formula which will give the same values of y as the formula

$$y = 25 \log_{10} x + 10 \cos \frac{x}{10} + 0.08x^2$$

between $x = 5$, and $x = 10$, with an accuracy of at least 1.5 per cent.

4. Find a simple formula to give the same values of y as the formula

$$y = 2 \log_{10} 5x + 100 \sin 0.05x + \frac{30}{x+2} + \sqrt{x+2}$$

correct to at least 2 per cent. between $x = 2$ and $x = 6$.

84. Laws of the Form $y = ax^n$.—If the observed values of two variables y and x are connected by a law of the form $y = ax^n$, we get, on taking logs of both sides of this equation,

$$(\log y) = n(\log x) + \log a$$

This is an equation of the first degree in $(\log y)$ and $(\log x)$, and therefore, if we plot values of $(\log y)$ as ordinates and values of $(\log x)$ as abscissæ, we get a straight line.

Accordingly, when such a law is suspected, we plot the logarithms of the two variables. If a straight line is obtained it follows that the above law is satisfied, and the values of n and $\log a$ may be found by substituting the co-ordinates of any two points on the line, and solving the resulting simultaneous equations.

EXAMPLE (1).—*The following quantities are supposed to follow a law of the form $y = ax^n$. Test this, and find the values of a and n .*

x	4	7	11	15	21
y	28.6	79.4	182	318	589

Taking logs, we get

Log x	0.602	0.845	1.041	1.176	1.322
Log y	1.456	1.900	2.260	2.502	2.770

Plotting $\log y$ and $\log x$ as ordinate and abscissa respectively, we get the straight line **AB**, Fig. 71.

\therefore $\log y$ and $\log x$ are connected by an equation of the first degree, and y and x are connected by a law of the form $y = ax^n$.

The equation to this straight line is

$$(\log y) = n(\log x) + \log a$$

Reading off from the figure the co-ordinates of **A** and **B** on this line, we get

$$\begin{aligned} \text{at A } \log x &= 0.64; \log y = 1.525 \\ \text{at B } \log x &= 1.24; \log y = 2.62 \end{aligned}$$

Substituting in the equation to the line

$$\begin{aligned} 1.525 &= 0.64n + \log a \\ 2.62 &= 1.24n + \log a \\ \therefore n &= 1.82; \log a = 0.357 \\ \text{and } \therefore a &= 2.27 \end{aligned}$$

$\therefore y$ and x are connected by the law $y = 2.3x^{1.82}$.

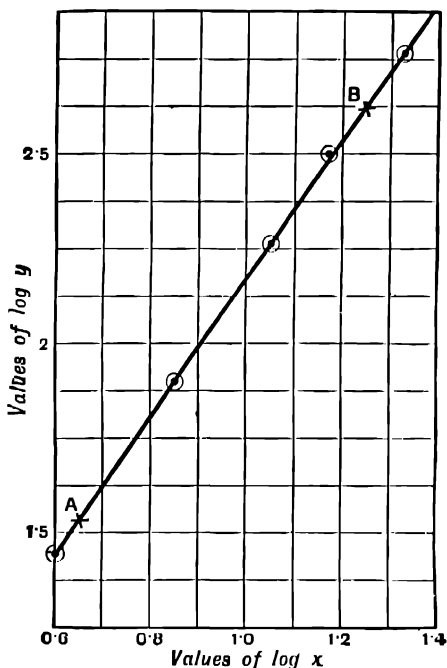

FIG. 71.

EXAMPLE (2).—*I* is the indicated horse-power required to drive a vessel of a certain type, of displacement *D* tons, at a speed of 10 knots. Find the law connecting *I* and *D*.

<i>D</i>	1720	2300	3200	4100
<i>I</i>	655	789	1000	1164

To try whether a law of the form $I = aD^n$ is satisfied, we plot the logs of *I* and *D*.

Log <i>D</i>	3.2355	3.3617	3.5051	3.6128
Log <i>I</i>	2.816	2.897	3.000	3.066

Plotting these values, we get a straight line *AB*, Fig. 72, and therefore *I* and *D* satisfy an equation of the form $I = aD^n$.

The equation of this line is

$$(\log I) = n(\log D) + \log a$$

We find that at **A**

$$\log I = 2.83; \log D = 3.256$$

and at **B** $\log I = 3.06; \log D = 3.60$

\therefore substituting

$$2.83 = 3.256n + \log a$$

$$3.06 = 3.60n + \log a$$

Solving, we get $n = 0.67; \log a = 0.65$

and $\therefore a = 4.47$

\therefore I and D are connected by the law

$$I = 4.47D^{0.67}$$

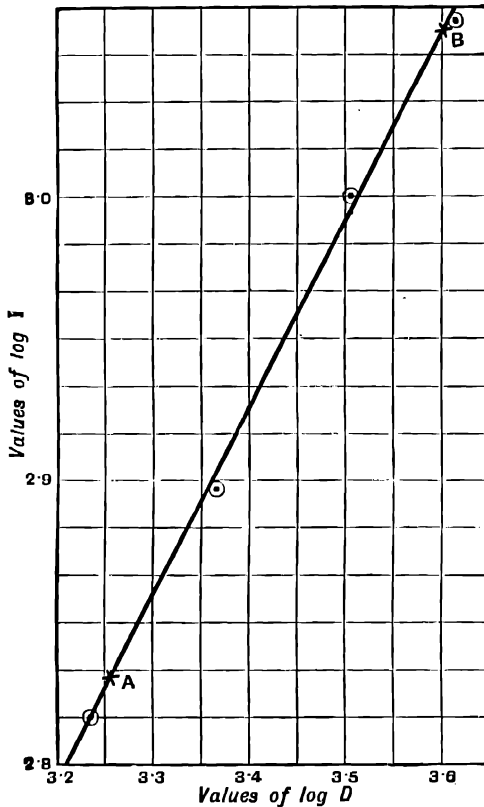

FIG. 72.

EXAMPLE (3).—The following table gives the loss of power E due to magnetic hysteresis, for different values of the magnetic induction B in a transformer core built up of a certain quality of thin sheet iron:—

Maximum B . .	2000	4000	6000	8000	10,000
Hysteresis loss E .	2869	8700	16,660	26,370	37,660

It is supposed that a law of the form $E = kB^n$ connects E and B. Test this, and find the actual law.

We have the following corresponding values of log E and log B :—

Log B	3'3010	3'6021	3'7782	3'9031	4'0000
Log E	3'4578	3'9395	4'2217	4'4211	4'5759

Plotting log E and log B we get a straight line, whose equation must be

$$\log E = n \log B + \log k$$

The student should plot the figure for himself, and verify the following measurements. We find, from the figure, that

$$\begin{aligned} \text{when } \log E = 3'8, \quad \log B = 3'51 \\ \text{,, } \log E = 4'325, \quad \log B = 3'84 \end{aligned}$$

Substituting these values and solving the resulting simultaneous equations, we get

$$n = 1'59, \log k = - 1'79, \text{ and } \therefore k = 0'016$$

\therefore the required law is $E = 0'016B^{1'59}$.

EXAMPLE (4).—*In the following table u is the volume in cubic feet of 1 lb. of saturated steam at a pressure of p lbs. per square inch. Find the law of the form $u^n = C$, connecting p and u .*

u	26'43	22'40	19'08	16'32	14'04	12'12	10'51	9'147	7'995
p	14'7	17'53	20'80	24'54	28'83	33'71	39'25	45'49	52'52

Taking logs, we get

Log u	1'4221	1'3502	1'2806	1'2127	1'1473	1'0835	1'0216	0'9612	0'9028
Log p	1'1673	1'2430	1'3181	1'3900	1'4599	1'5277	1'5938	1'6580	1'7204

and, taking logs, If $pu^n = C$, we have $p = Cu^{-n}$ (1)

$$\log p = - n \log u + \log C \text{ (2)}$$

herefore, if we plot log p and log u , we shall obtain a straight line whose slope to the axis of log u is $-n$.

Plotting the values of log u and log p above, we obtain the straight line AB (Fig. 73).

We find by inspection of the figure, that at the

$$\begin{aligned} \text{point A, where } \log u = 0'9, \log p = 1'722 \\ \text{and at B, where } \log u = 1'4, \log p = 1'190 \end{aligned}$$

∴ substituting in equation (2), we get

$$\begin{aligned} 1.722 &= -n \times 0.9 + \log C \\ 1.190 &= -n \times 1.4 + \log C \end{aligned}$$

Solving these simultaneous equations in n and $\log C$, we get

$$n = 1.064, \log C = 2.6796, \text{ and } \therefore C = 478.2$$

∴ the required law connecting p and u is $p u^{1.064} = 478.2$.

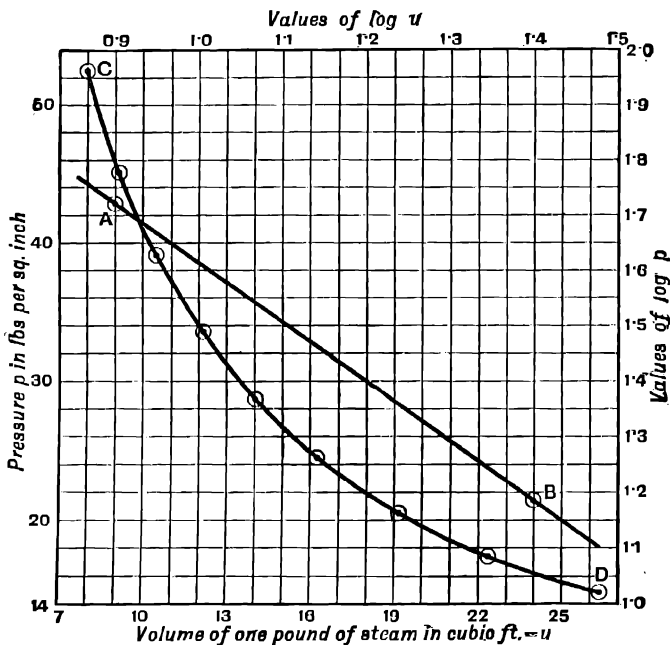

FIG. 73.

This is, therefore, the equation of the curve CD, which is obtained by plotting the values of p and u .

EXAMPLES.—LI.

Find the law connecting y and x when the following corresponding values are given:—

1

x	2.5	3	3.7	4.8
y	9.9	15.65	26.4	50.8

2.

x	10	17	23	28	35
y	41·8	98·5	162	221·5	316

3.

x	132	154	165	181
y	32·7	40	44	50

4.

x	4·5	5·7	7·3	8·9
y	227	464	976	1770

5.

x	2	3·5	4·2	7	9·1
y	20·8	195	407	3120	8960

6.

x	253	270	305	360
y	137	194	370	895

7.

x	5	7·3	8·2	9·6
y	2·4	0·769	0·543	0·337

8.

x	1·5	2·8	5·6	8·3
y	0·573	0·243	0·094	0·055

9.

x	0'00155	0'00316	0'00631	0'040	0'144	0'316
y	67'6	39'8	23'4	7'1	3'5	2'0

In the following examples p and v are corresponding values of the pressure and volume of steam and various gases in adiabatic expansion. Find whether they are connected by a law of the form $p v^n = C$; and, if they are, find the value of n in each case.

10. Steam.

v	2	4	6	8	10
p	68'7	31'3	19'8	14'3	11'5

11. Steam.

v	4	5	6	8	10
p	71'7	58'7	49'6	38'5	31'5

12. Superheated steam.

v	2	4	6	8	10
p	105	42'7	25'3	16'7	13

13. Mixture in cylinder of a gas-engine.

v	0'8	2	4	6	9
p	200	57	22	12'6	7'2

14. Air.

v	2	4	6	8	10
p	18'8	7'07	4	2'66	1'95

15. Air is compressed without gain or loss of heat. The following table gives the absolute temperature (Fahr.) at different pressures. Find the law connecting t and p .

Absolute temp. t° Fahr. . .	521	637	779	876
Pressure p lbs. per sq. inch.	15	30	60	90

16. F is the force between two magnetic poles at distance d cms. apart. Find the law connecting F and d .

d cms.	1'2	1'9	2'3	3'2	4'5
F dynes	4'44	1'77	1'21	0'625	0'316

17. D is the diameter in inches of wrought-iron shafting required to transmit H horse-power at 70 revolutions per minute. Find the law connecting D and H .

H	10	20	30	40	50	60	70	80
D	2'11	2'67	3'04	3'36	3'61	3'82	4'02	4'22

18. D is the diameter in inches of wrought-iron shafting required to transmit 50 horse-power at N revolutions per minute. Find the law connecting D and N .

N	20	40	60	80
D	5'46	4'34	3'80	3'45

19. At the following draughts a particular vessel has the following displacements:—

Draught h feet	18	13	11	9'5
Displacement V cubic feet	107200	65800	51200	41100

Plot $\log V$ and $\log h$, and find a law connecting V and h .

20. I is the indicated horse-power needed for the propulsion of ships of a certain class at 10 knots. D is the displacement in tons. Plot $\log I$ and $\log D$, and find an approximate law connecting I and D .

D	1100	1530	1820	2500	3130
I	440	550	620	770	890

21. The following are results of Hodgkinson's experiments on the strength of cast-iron pillars. W is the breaking weight of a pillar 10 ft. long, and of diameter d inches.

It is known from many similar experiments that W and d are connected by a law of the form $W = kd^n$. Find this law as given by the mean of the first two and the mean of the second two results.

d	2.511	2.496	1.530	1.541
W	63500	58325	11200	10870

(*Phil. Trans.*, 1841.)

22. A steamship at the following speeds (v knots) uses the following indicated horse-power (P):—

v	10	12	14	16	18	20
P	1066	1912	3216	4951	7361	10,355

Find if there is a law of the form $P = av^n$, and if so what are the most probably correct values of a and n . There are experimental errors in the observed values of v and P .
(Board of Education Examination.)

23. The following table gives the loss of power E due to magnetic hysteresis for different values of the magnetic induction B in a transformer core of ordinary sheet iron. Find the law connecting E and B .

B	1000	3000	5000	7000	9000
E	1262	7380	16600	28400	42400

24. The following data are taken from the wiring rules of the Institution of Electrical Engineers. C is the maximum current in amperes for rubber-covered wires, exposed to high external temperatures, of cross-sectional area A square inches. Find the law connecting C and A .

C	3.2	5.9	9.0	22.0	42.0	68.0	84	102
A	0.001810	0.004072	0.007052	0.02227	0.05	0.09442	0.125	0.1595

25. In the following, C and A have the same meaning with reference to wires exposed to ordinary external temperatures. Find the law connecting C and A .

C	113	237	354	425	493	624	688	750
A	0.1	0.2455	0.4	0.5	0.6	0.8	0.9	1.0

26. The following are results of Beauchamp-Tower's experiments on friction. μ is the coefficient of friction in a certain bearing running at a velocity of V feet per minute.

V	105	157	209	262	314	366	419	471
μ	0.0018	0.0021	0.0025	0.0028	0.003	0.0033	0.0036	0.004

Find the law connecting μ and V .

(Proceedings of the Institution of Mechanical Engineers, 1883, pp. 633-653.)

27. μ is the coefficient of friction in a bearing revolving at a speed of 20 ft. per minute under a normal load L lbs. Find the law connecting μ and L .

L	443	333	211	89
μ	0.00132	0.00168	0.00247	0.0044

85. **Compound Interest Law** $y = ae^{bx}$.—If $y = ae^{bx}$, we have, taking logs to base 10,

$$\begin{aligned} \log_{10} y &= bx \log_{10} e + \log_{10} a \\ &= 0.4343b \cdot x + \log_{10} a \end{aligned}$$

This equation is of the first degree in $\log_{10} y$ and x , and therefore, if we plot $\log_{10} y$ and x we get a straight line whose slope to the axis of x is $0.4343b$.

EXAMPLE (1).—Test the following values of x and y for a law of the form $y = ae^{bx}$, and find the values of the constants.

y	3.86	4.2	5.1	6.3	7
x	2.701	2.870	3.258	3.681	3.892

We have the following values of $\log_{10} y$:—

log ₁₀ y	0.587	0.623	0.708	0.799	0.845
---------------------	-------	-------	-------	-------	-------

On plotting $\log_{10} y$ and x we get the straight line **AB**, Fig. 74.

The equation of this line is

$$\log_{10} y = 0.4343bx + \log_{10} a$$

At A, $\log y = 0.576$, $x = 2.625$

at B, $\log y = 0.8355$, $x = 3.850$

Substituting in the equation, and solving the resulting two simultaneous equations in b and $\log a$, we get

$$b = 0.488, \log a = 0.02$$

$$\text{and } \therefore a = 1.047$$

\therefore the required law connecting y and x is

$$y = 1.047e^{0.488x}$$

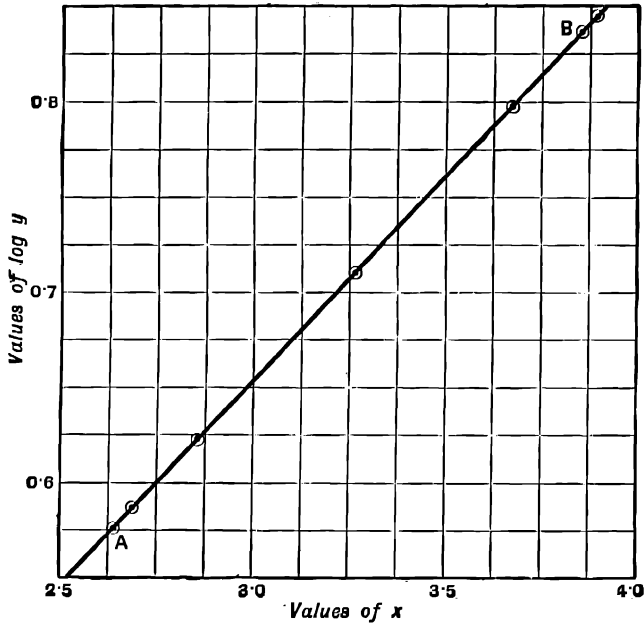

FIG. 74.

EXAMPLE (2).—The following are the results of an experiment to find the law governing the friction of a string wrapped round a metal bar.

A weight of 2 oz. was hung at one end of the string, and weights W at the other, so as to counterbalance the weight of 2 oz., and the friction, and to cause slipping. The extent of the string in contact with the bar was measured by the angle θ , which is subtended at the centre of the cross-section of the bar, e.g. when the string is wrapped once round $\theta = 2\pi$ radians. It is required to find the law connecting W and θ .

θ radians .	0.5π	π	1.5π	2π	2.5π	3π	3.5π	4π	4.5π	5π	5.5π	6π
W oz. . .	2.875	4.000	5.706	8.901	12.437	14.700	19.062	26.5	33.75	40.00	52.00	76.00

On plotting the values of θ and W we obtain the curve AB , Fig. 75. The theory of the subject suggests that the law is

$$W = we^{\mu\theta}$$

where μ is the coefficient of friction, and $w = 2$ oz., is the constant weight hung at one end of the string.

Taking logs, we get

$$\begin{aligned} \log_{10} W &= \mu\theta \log_{10} e + \log_{10} w \\ &= 0.4343\mu \cdot \theta + \log w \end{aligned}$$

To try whether a law of this form is satisfied, we plot $\log W$ and θ . We obtain the straight line CD , as representing the results best on the whole, thus verifying that the law is of the form $W = ae^{\mu\theta}$.

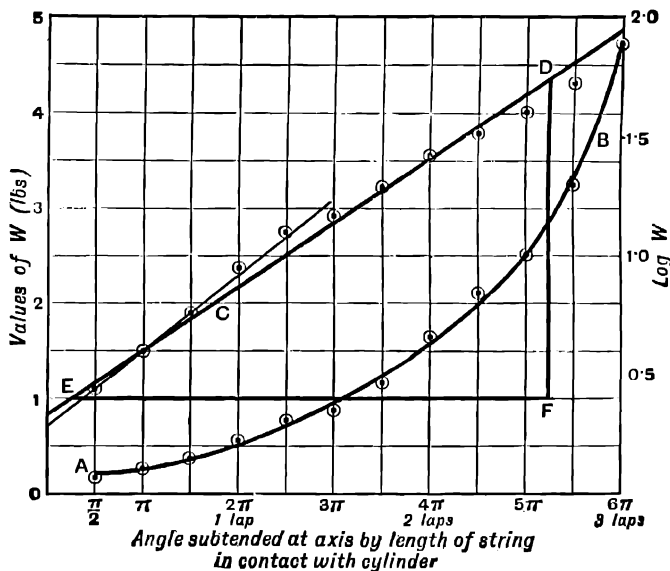

FIG. 75.

By substituting the co-ordinates of the points D and E on this line, and solving the resulting simultaneous equations, we get

$$\mu = 0.196, a = 2.1$$

and the law is $W = 2.1e^{0.196\theta}$.

The theory suggests that we should find $a = w = 2$ oz., and it is found that this value is given very accurately by a straight line representing the first five results. This is a good example of the advantage of the graphic method of treating experimental results.

By working out algebraically the values of a and μ for each pair of results taken two at a time, and taking averages, we should obtain results nearly as above, but there would be nothing to show the cause of the difference between the value of a found by experiment and the value to be expected from the theory. We can see at once, however, from the plotted values in Fig. 75, that the law $W = we^{\mu\theta}$ is

followed very closely by the first five observations, but that, as the weight increases, the same law is not so accurately followed.

EXAMPLE (3).—*Newton's law of cooling.* The following are the results of Winkelmann's experiments to find the law which governs the rate of cooling of a heated body suspended in air. θ is the excess in temperature of the body over the temperature of its surroundings, at time t seconds from the beginning of the experiment.

θ	19.9	18.9	16.9	14.9	12.9	10.9	8.9	6.9
t	0	3.45	10.85	19.30	28.80	40.10	53.75	70.95

According to Newton's law of cooling we should have

$$\theta = \theta_1 e^{-at}$$

where a is constant and θ_1 = the temperature when t is $0 = 19.9$.

To test how far the above results follow this law, we have, taking logs of θ —

$\log \theta$	1.2989	1.2765	1.2279	1.1732	1.1106	1.0374	0.9494	0.8388
---------------	--------	--------	--------	--------	--------	--------	--------	--------

Plotting $\log \theta$ and t we get a straight line sloping downwards as t increases, thus verifying that θ and t follow a law of the form $\theta = \theta_1 e^{-at}$.

Taking logs, we get

$$\log_{10} \theta = -at \log_{10} e + \log_{10} \theta_1 = -0.4343a \cdot t + \log_{10} \theta_1$$

as the equation to this straight line.

Substituting the co-ordinates of two points on the line, and solving the resulting simultaneous equations, we get

$$a = 0.015, \theta_1 = 19.9$$

\therefore the temperature and the time are connected by the law $\theta = 19.9e^{-0.015t}$.

The student should draw the figure from the above data, and verify this result.

EXAMPLES.—LII.

Find the law connecting y and x in the following cases:—

1.

x	0.4	0.72	1.1	1.5	2
y	3.32	8.7	27.3	91	407

2.

x	2.4	3.6	4.8	5.3	6.9
y	1.16	2.06	3.75	4.9	10.7

3.

x	0.5	0.8	1.3	2.8	3.2
y	99	54	20	1.0	0.49

4.

x	0	2.1	5.6	9.3	11.5
y	20	18.92	17.34	15.8	14.96

5.

x	1.5	2.3	4.1	5.8	6.2
y	1459	3250	19600	108000	161000

6.

x	1.7	2.8	3.9	4.7	5.5
y	502	167	55.4	24.9	11.2

7.

x	4.0	8.4	12.8	14.6	16.0
y	1.5	2.3	3.6	4.3	5.0

8.

x	9	31.5	43.5	55.0	60
y	12	20	24	30	33

9.

x	31.5	52.4	68.8	72.8
y	6.6	11.1	16.7	18.5

10. θ and W have the same meaning as in Example 2, p. 154. Show that W and θ are connected by a law of the form $W = we^{\mu\theta}$, and find the coefficient of friction, μ .

θ radians .	0.5π	π	1.5π	2π	2.5π	3π	3.5π
W ozs. .	5.35	7.15	9.55	12.8	17.12	22.9	30.8

11. Find the coefficient of friction μ from the following data, as in the last example. θ must be found from the number of laps. 1 lap = 2π radians.

No. of times cord laps round	$\frac{1}{2}$	$\frac{1}{2}$	$\frac{3}{4}$	1	$1\frac{1}{2}$	$1\frac{1}{2}$	$1\frac{3}{4}$	2
W	2.61	3.40	4.44	5.78	7.55	9.85	12.8	16.7

12. The following are results of experiments on lubrication. μ is the coefficient of viscosity of olive oil at temperature t° Fahrenheit. Find the law connecting μ and t .

t	61	81	94	120
$\frac{\mu}{107}$	130	84	63	36

13. The following is taken from a work on ballooning. It is an estimate of the volume V which a balloon of a certain known weight filled with hydrogen must have so that it may be raised to a height z .

V cu. metres	1.25	10	640	80,000	1,250,000
z metres . .	12,900	18,400	29,500	42,300	49,700

Find a formula to calculate the volume required to rise to any height z .

14. The following table gives the pressure p in inches of mercury, as measured by the barometer at various heights h above the sea, when the pressure at the sea-level is 30 inches :—

h feet . .	0	886	2753	4763	6942	10593
p inches . .	30	29	27	25	23	20

Show that a law of the form $p = Ae^{kh}$ connects p and h , and find A and k .

The following three examples give results of Winkelmann's experiments to find the rate of cooling of a body in air. θ is the excess in temperature of the body over the temperature of its surroundings at time t seconds from the beginning of the experiment. According to Newton's law of cooling $\theta = \theta_1 e^{-at}$. Test this for each case, and if the law applies find the values of the constants θ_1 and a .

15.

$\theta^\circ \text{C.}$	19'32	18'32	16'32	14'32	12'32	10'32	8'32
t seconds	0	10	31'7	56'4	84'2	117'6	158'7

16.

θ	20'65	18'65	16'65	14'65	12'65	10'65	8'65
t	0	16'9	35'3	55'9	80'1	108'6	143'1

17.

θ	118'97	116'97	114'97	112'97	110'97	108'97	106'97
t	0	12'1	25'8	41'7	59'7	82'0	109'0

In this case we find that the values of $\log \theta$ and t do not give a straight line when plotted, but lie on a regular curve of small curvature. Find an approximate law of the form

$$\log \theta = a + bt + ct^2$$

18. s is the weight of potassium chromate which will dissolve in 100 parts by weight of water at temperature $t^\circ \text{C.}$ Find an approximate law of the form $s = ae^{bt}$, connecting s and t .

t	0	10	27'4	42'1
s	61'5	62'1	66'3	70'3

The values of $\log s$ and t do not give points lying exactly on a straight line but on a regular curve. Find a law of the form

$$\log s = a + bt + ct^2$$

which will fit this curve better than the compound interest law found above.

19. The following are results of Beauchamp-Tower's experiments. μ is the coefficient of friction of a certain bearing in a bath of lard oil, at temperature $t^\circ \text{F.}$ and speed 209 ft. per minute.

t	120	110	100	90	80	70	60
μ	0.0035	0.0039	0.0045	0.0052	0.0063	0.0080	0.0103

Find a roughly approximate law of the form $\mu = ae^{bt}$ connecting μ and t .
 (Beauchamp-Tower, *Proceedings of the Institute of Mechanical Engineers*, 1883, pp. 633-653.)

20. The following results were obtained with the same bearing, running at 419 ft. per minute. Find a law connecting μ and t .

t	120	110	100	90	80	70	60
μ	0.0051	0.0059	0.0071	0.0085	0.0102	0.0124	0.0148

CHAPTER IX

DETERMINATION OF MEAN VALUES AND AREAS

86. THE student is already familiar with the arithmetical method of finding the mean or average value of a number of separate values of a quantity. The values are added together, and the sum is divided by the number of values taken.

For example, if we have four rectangles on equal bases of 1" and of heights 2", 5", 7", 6" respectively, their mean height is $\frac{2+5+7+6}{4} = 5''$.

If they are placed side by side so that their bases are in a straight line, as in the figure, then their mean height is the height of a rectangle on the same base, and having the same area as the four given rectangles together.

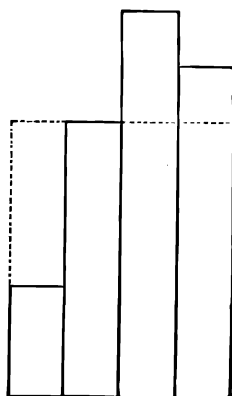

FIG. 76.

87. Mean Value of a Variable.—It often happens in physical science that, instead of having given a number of isolated values of a quantity, we know the way in which one quantity varies continuously with respect to another, and we require to find the mean value of the first with respect to the second: for example, we may know the way in which the speed of a train varies between any two definite instants, and we may require to find its average speed during that interval, *i.e.* the constant speed with which it would describe the same distance in the same time; or we may know the pressure on the piston of a steam-engine at any point of the stroke, and require to find the average pressure throughout the stroke, *i.e.* the constant pressure which would do the same amount of work in acting through the same stroke.

We shall define the mean value of a variable quantity by reference to a graphic construction as follows:—

Let y and x be two variables, such that y is known when x is known.

Plot a curve having values of y as ordinates and values of x as abscissæ. Then the mean value of y with respect to x between any two values a and b of x is the height of a rectangle having the same area as that enclosed by the curve, and the axis of x between the two ordinates at $x = a$ and $x = b$, and standing on the same base $b - a$.

E.g. in Fig. 77 the ordinate represents the velocity v of a point at any time t , and the line AB shows the relation between v and t . The mean value of v with respect to t is represented by the height of the rectangle $CDGF$, which stands on the same base CD as, and whose area is equal to the area of, $CABD$.

In explaining practical methods of finding mean values, we shall first consider the simple case when the curve showing the connection between the two variable quantities is a straight line.

EXAMPLE (1).—*A point moves along a straight line, so that its velocity v at time t is given by the following table:—*

v feet per second .	8.5	14.25	20.1	23
t seconds . . .	0	2	4	5

Find the time average of the velocity from $t = 0$ to $t = 5$ seconds.

On plotting the given values of v and t we obtain the straight line AB (Fig. 77).

We require to construct a rectangle on the same base CD , and having its area equal to the area $ABDC$.

Bisect AB at E , draw FEG parallel to CD and complete the rectangle $CFGD$. Then CF represents the required time average of the velocity.

For the triangles AFE and BGE are equal, and the rectangle $CFGD$ can be

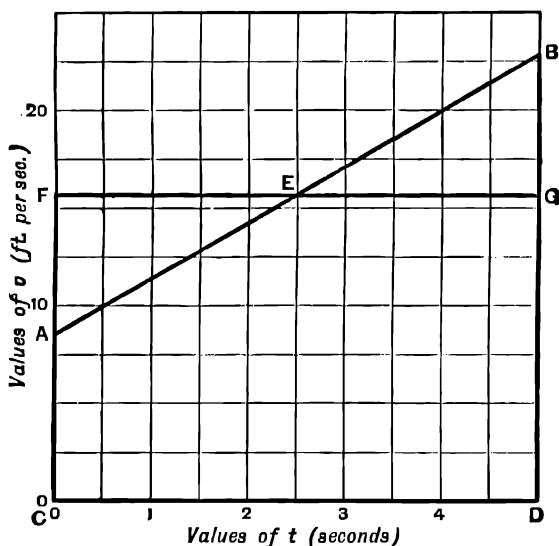

FIG. 77.

formed from the figure $CABD$ by cutting off the triangle BGE and adding the equal triangle AFE . Thus the rectangle $CFGD$ is equal to the figure $CABD$.

We find that CF measures 15.75, and therefore the average velocity is 15.75 ft. per second.

When the curve is a straight line we see that the mean value of the ordinate is equal to the ordinate at the middle point of the base CD , and is the arithmetic mean of the ordinates at the extremities C and D . When the portion of the curve considered is nearly but not quite a straight line, it is evident that we shall get an approximation to the mean value by taking the ordinate at the mid-point of the portion of the base considered.

We use this principle to find approximately the mean value of any variable quantity which can be represented by a continuous curve.

EXAMPLE (2).—A point moves along a straight line so that its velocity v at any time t is given by the following table:—

v ft. per second	8.5	9.8	11.6	17.8	23
t seconds	0	1	2	4	5

Find the time average of the velocity from $t = 0$ to $t = 5$ seconds.

On plotting the given values of v and t we obtain the curve AB (Fig. 78).

We require to find the mean height of the figure $ABDC$.

We divide the figure into any given number, usually 10, of strips of equal width,

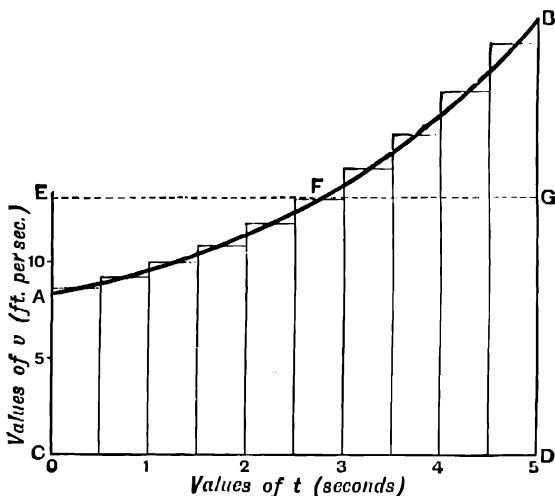

FIG. 78.

and assume that the portion of the curve AB at the top of each strip may be treated as if it were a straight line; accordingly we take the mean height of each strip as equal to the height at the mid point of its base.

This is equivalent to substituting a number of rectangles on equal bases for the strips of the area $ABDC$.

The height of each rectangle is equal to the ordinate to the curve AB at the mid point of the base of the corresponding strip.

The average value of the heights of these rectangles is the mean height of the curve AB , being the height of a rectangle on the base CD , having its area equal to the sum of the areas of the smaller rectangles, *i.e.* equal to the area $ABDC$ (see § 86).

We find the mean heights of the respective strips of the area $ABDC$ to be 8.75, 9.4, 10.2, 11.1, 12.2, 13.4, 15.0, 16.75, 19.0, 21.5. The mean value of these is 13.73.

This is the height of the rectangle $ECDG$ in the figure. This rectangle may be supposed formed by cutting off the area FGB from the original figure, and fitting it into the space EAF , which must be of the same area, but not necessarily of the same shape.

Note that EG does not in this case bisect AB , and that the mean ordinate is not the arithmetic mean of the two extreme values.

Note also that the mean value of a variable is always equal to the actual value at some point within the interval considered.

We thus get the following rule for finding the mean ordinate of any curve. Consider a curve having values of y as ordinates and values of x as abscissæ. Divide the area between the curve and the axis of x into any number of strips of equal width. If the top of each strip is nearly straight, take the height of each strip at the mid point of its base as the mean height of the strip.

Then the average value of the mean heights of the strips is the mean ordinate of the whole curve.

NOTE.—If the curve is so irregular that the strips would have to be made very narrow before we could take the height in the middle of each strip as its mean height, we can estimate the mean height of any strip by the eye. If $ABCD$ in Fig. 79 represents one of the strips into which an irregular area is divided, it is evident that the height of the horizontal line EF gives a more accurate value of its mean height than would be obtained by measuring the height at the mid point of AB . We estimate the position of EF so that the area cut off by EF from the strip $ABCD$, appears equal to the area which would have to be added at the corners to form the rectangle $ABFE$. Considerable accuracy in estimating mean ordinates by this method can be attained by practice. The student of the steam-engine will find it useful to bear in mind this note when finding the mean pressure from an indicator diagram, especially with respect to the two outer strips into which this diagram is divided.

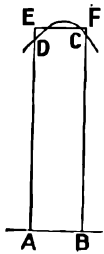

FIG. 79.

More advanced methods of finding mean values will be treated in Chapter XIX.

88. Area of an Irregular Figure—(I.) Mean Ordinate Method.—If we agree to measure the length and breadth of an irregular figure in two

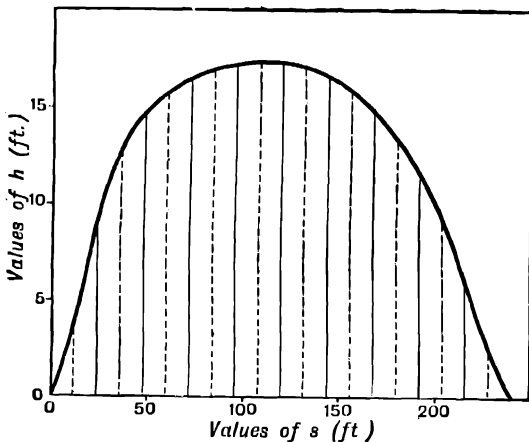

FIG. 80.

fixed directions at right angles to each other, then the area of the figure is the product of its length into its mean breadth.

To find the area of an irregular figure we find the mean breadth by the method of the last paragraph and multiply the result by the length of the figure.

EXAMPLE.—The following table gives the half-width h of a horizontal section of a ship at different distances s from one end:—

s ft.	0	20	40	80	120	160	200	220	240
h ft.	0·1	6·7	13·5	16·7	17·1	15·4	10·7	5·0	0·1

Find the area of the section.

Plotting the values of h and s , we get the curve (Fig. 80). To find the mean value of h , we divide the area between this curve and the axis of s into ten strips of equal width. The values of h at the mid-point of the base of each strip are 3·7, 12·5, 15·6, 16·8, 17·2, 16·8, 15·7, 13·5, 9·8, 2·5. The mean of these is 12·41.

$$\therefore \text{the area of the section} = (\text{mean value of } h) \times \text{length} \\ = 12\cdot41 \times 240 = 2978 \text{ sq. ft.}$$

80. Simpson's Rule.—The following method is more accurate than the foregoing in certain cases determined by the assumption mentioned below.

Draw ordinates dividing the area into an even number of strips of equal width.

Thus there will be an odd number of ordinates, including the first and last, which are drawn at the boundaries of the figure.

Number the ordinates y_1, y_2, y_3, \dots

Add together the first and last ordinates, twice the sum of the other odd ordinates, and four times the sum of the even ordinates; multiply the result by one-third of the distance between two adjacent ordinates. The result is the area of the figure.

For example, if the area is divided into ten strips there are eleven ordinates, and the area is equal to

$$\frac{h}{3} \{y_1 + y_{11} + 2(y_3 + y_5 + y_7 + y_9) + 4(y_2 + y_4 + y_6 + y_8 + y_{10})\}$$

where h is the distance between two adjacent ordinates.

This method is based on the assumption that we can draw arcs of parabolas, to fit the curve approximately, through the tops of the ordinates taken three at a time, but the student will not be in a position to follow the proof until a later stage (see § 137)

EXAMPLE.—To find the area of the section of a ship in the last example by Simpson's rule.

In Fig. 80 there are eleven ordinates, and therefore the area is

$$\frac{h}{3} \{y_1 + y_{11} + 2(y_3 + y_5 + y_7 + y_9) + 4(y_2 + y_4 + y_6 + y_8 + y_{10})\} \\ = 8\{0\cdot1 + 0\cdot1 + 2(14\cdot5 + 17\cdot1 + 16\cdot3 + 12\cdot1) + 4(8\cdot5 + 16\cdot3 + 17\cdot1 + 14\cdot6 + 6\cdot1)\} \\ = 2965$$

Note that this result is about 1 per cent. smaller than the former. The result obtained by Simpson's rule is more likely to be correct.

EXAMPLES.—LIII.

1. There are two variables y and x , which are connected together so that they have the following pairs of corresponding values.

x	0	1	2	3	4
y	5	2	1	2	5

Find the mean value of y with respect to x between $x = 0$ and $x = 4$.

2. A quantity of steam expands from volume 2 to volume 10. The value of the pressure p when the volume is v is given by the following table:—

v	2	4	6	8	10
p	68·7	31·3	19·8	14·3	11·5

Find the average pressure between $v = 2$ and $v = 10$.

3. v is the volume of the gas in the cylinder of a gas-engine when its pressure is p . Find the average pressure as v changes from 1 to 9.

v	0·8	2	4	6	9
p	200	57	22	12·6	7·2

4. The following table gives the pull P lbs. at the drawbar of an electric locomotive at time t seconds from starting.

P	1150	1450	1320	1350	1040	1300
t	0	12·5	25	37·5	43	50

Deduct 300 lbs. for friction, and find the time average of the remaining force, $P - 300$, which causes the motion of the train.

5. The following table gives the draw-bar pull P lbs. exerted by an electric locomotive, at distance s feet from rest.

P	930	1000	930	835	1000	1225	1325	1300	1230	1000	800	650
s	0	15	30	45	80	110	160	180	200	227	260	300

Find the space average of the force P from $s = 0$ to $s = 300$.

6. v is speed of a car at time t from rest. Find the time average of the speed.

t seconds . . .	0	5	10	15	20	25	30
v ft. per second .	0	3.7	7.5	10.85	12.95	13.7	14

7. h is the height above the sea-level of various points on a certain road; s is the distance, measured along the road, of the respective points from a fixed point on the road. Find the average height of the road above the sea-level.

h ft.	100	135	156	184	160	148	160
s miles	1	1.5	2	2.5	3	3.5	4

NOTE.—Since h is small compared with s , the distances s may be taken as if they were measured in a horizontal plane.

8. Draw a circle of 2 ins. radius, and find its average width measured parallel to a fixed diameter.

9. Find the mean value of x^2 between $x = 0$ and $x = 1$. (Plot the curve $y = x^2$, and find its mean ordinate.)

10. Find the mean value of the sine of an angle when the angle has all values between 0 and $\frac{\pi}{2}$ radians.

NOTE.—The values of the angle must be plotted in radians.

11. Plot the curve $y = \sin x$ from $x = 0$ to $x = 2\pi$ radians. By squaring the ordinates of this, and plotting on the same axis of x , obtain the curve $y = \sin^2 x$. Find the mean value of $\sin^2 x$, taking x in radians. Note that the mean value of $\sin^2 x$ is not the same as the square of the mean value of $\sin x$. The result of this example is important in the theory of alternating electric currents.

12. A gas expands from volume 2 to volume 10, so that its pressure p and volume v satisfy the equation $pv = 100$. Find the average pressure between $v = 2$ and $v = 10$.

13. A body weighing 500 lbs. moves along a straight line without rotating, so that its velocity v at time t is given by the following table:—

t seconds . . .	1	5	9	13
v ft. per second .	1.53	1.65	1.77	1.89

Its kinetic energy is equal to one-half the product of the mass into the square of the velocity. Find the mean value of the kinetic energy from $t = 1$ to $t = 13$.

NOTE.—To obtain the energy in foot-pounds take 32.2 lbs. as the unit of mass.

14. Find the area between the curve given by the following values, and the axis of x , from $x = 2$ to $x = 4$.

x	2.0	2.6	3.0	3.25	3.6	3.8	4.0
y	3.03	4.61	5.80	6.59	7.76	8.46	9.19

15. Find the area between the curve given by the following values, and the axis of x from $x = 3.10$ to $x = 5.20$:—

x	3.10	3.56	4.1	4.85	5.20
y	22.47	19.19	15.97	12.85	11.72

16. Find the area between the following curve, and the axis of x from $x = 0$ to $x = 96$:—

x	0	12	24	48	72	84	96
y	1.2	61.2	86.0	121.0	96.6	76.8	1.2

17. Find the area between the curve given by the following data, and the axis of x from $x = 0$ to $x = 5$:—

x inches.	0	1.0	2.0	2.5	3.3	4.0	4.4	5.0
y inches.	1	2.05	2.54	2.61	2.40	2.03	1.94	2.25

18. Find the area lying between the following curve, and the axis of x from $x = 0.5$ to $x = 5.3$:—

x	0.5	1.2	2.5	3.6	4.5	5.3
y	3.42	3.6	4.34	4.25	3.75	3.27

19. Find the area of a half-section of a ship at the water-level, of which the curved form is defined by the following equi-distant ordinates spaced 12 ft. apart :—
Ordinates (feet)—

0.1, 5.1, 7.17, 8.75, 10.1, 9.17, 8.05, 6.4, 0.1.

(Board of Education Examination in Naval Architecture, 1902.)

20. The numbers given below refer to horizontal sections of the same ship at different distances above the keel. h is the half-width across the section at distance s from the stern. Find the area of the half-section in each case, by Simpson's rule.

	<i>s</i> feet	0	20	40	80	120	160	200	220	240
1 ft. above keel	<i>h</i>	0·1	1·4	5·6	11·1	13·1	10·5	5·7	1·7	0·1
2 ft. above keel	<i>h</i>	0·1	2·6	8·2	13·7	15·6	12·6	7·5	2·7	0·1
4 ft. above keel	<i>h</i>	0·1	4·6	11·5	15·9	17·1	14·6	9·5	4·1	0·1
8 ft. above keel	<i>h</i>	0·1	9·0	14·7	17·0	17·4	15·8	11·6	6·0	0·1
10 ft. above keel	<i>h</i>	0·1	11·1	15·3	16·9	17·4	16·0	12·5	9·1	0·1

(Board of Education Examination in Naval Architecture, 1902.)

21. The following are values of x and y for a certain curve:—

x	1	1·8	2·5	3·15	4	4·6	5·4	6·3	6·8	7·0
y	0	1·06	1·71	2·10	2·36	2·39	2·30	1·80	1·2	0·8

Find the area enclosed by this curve, the axis of x and the ordinates at $x = 1$ and $x = 7$, by Simpson's rule, using (1) 5 ordinates, (2) 7 ordinates, (3) 9 ordinates, (4) 11 ordinates, (5) 13 ordinates, (6) 21 ordinates, respectively.

Observe and record the time taken to obtain each of the above 6 results. Taking the last result as accurate calculate the percentage error in each of the others. Take the reciprocal of the percentage error as an index of the accuracy of each method.

Compare the accuracy of the different results, and also the time occupied. In which of the above results do you obtain the highest accuracy per minute occupied. Also find the area by means of a planimeter if you have the opportunity.

22. Find the area in the last example by mean ordinates, dividing the base into 4, 6, 8, 10, 12, 20 divisions respectively.

Compare accuracy obtained and time occupied as before.

23. Plot the curve which passes through the following points in the order given, and find the area which it encloses:—

x	0·9	1·9	2·6	3·4	4·1	4·7	5·55	6	6·4	6·46	6·3
y	0·6	0·2	0·25	0·38	0·25	0·16	0·3	0·6	1·35	1·8	2·59

x	5·9	5·4	4·5	3·5	3·1	2·1	1·4	0·7	0·42	0·21	0·5	0·9
y	2·9	2·7	2·51	2·8	3·19	3·56	3·46	3	2·6	1·9	0·99	0·6

CHAPTER X

RATE OF INCREASE

90. The plotting of curves from their equations or from tabulated lists of values will already have made the student familiar with the conception of two mutually dependent variables. We regarded y and x as two quantities, such that definite changes in x were accompanied by definite changes in y , and the nature of these changes was exhibited to the eye by a curve.

We shall now consider more fully the rate of change of one quantity with respect to another.

Consider the following cases:—

(a) The following table shows the average height at different ages of a boy in Great Britain:

Age t years . . .	5	6	12	13	19	20
Height h inches .	41'03	44'00	54'99	56'91	67'29	67'52

From these numbers we infer that the mean rate of growth between the ages of 5 and 6 is 2'97 inches per annum, between 12 and 13 it is 1'92 inches per annum, between 19 and 20 it is 0'23 inches per annum.

If t represents the age measured in years and h the height in inches, we use the symbol $\frac{dh}{dt}$ to represent the rate at which h is increasing per unit increase of t .

Thus the above statement may be expressed in another way by saying that the mean value of $\frac{dh}{dt}$ is 2'97 between the ages of 5 and 6 years, 1'92 between 12 and 13, and 0'23 between 19 and 20.

For the present the student should regard the symbol $\frac{dh}{dt}$ simply as an abbreviation for "the rate of increase of h with respect to t ."

(b) The population of England and Wales in 1881 was 25'974 millions, in 1891 it was 29'002 millions. The increase was 3,028,000 in 10 years, an average increase of 302,800 per annum. If P denotes the population and t the time in years, the mean value of $\frac{dP}{dt}$ is thus 302,800 between the values, 1881 and 1891, of t .

(c) A bar of zinc, which is 10 ins. long at temperature 0° C., measures 10'03 ins. at 100° C., so that the length increases 0'03 in. while the temperature increases 100° . Thus the mean rate of increase of the length is

0.0003 in. per degree, or, if l is the length in inches and θ the temperature in degrees, the mean value of $\frac{dl}{d\theta}$ is 0.0003.

(d) If the same bar of zinc is 1 sq. in. in cross-section, and is subjected to a tension of one ton, it will stretch 0.02 in. Therefore, if W is the tension in pounds the mean value of $\frac{dl}{dW}$ is $\frac{0.02}{2240} = 0.000008925$.

(e) A train passes a point **A** distant 12 miles beyond a certain station at 1.50, and a point **B** ten miles further on at 2.20. It has travelled 10 miles in 30 minutes, and its average speed is therefore 20 miles an hour, or, if s is the distance in miles traversed along the line from the station at time t hours, the mean value of $\frac{ds}{dt}$ is 20.

On considering the above cases, we notice that in every case two quantities have to be specified: (a) the quantity, such as height, population, length of a bar, distance, whose rate of increase is being measured, and (b) a second quantity, such as time, temperature, or tension, with respect to which that rate of increase is measured. The first of these quantities is called the **dependent**, and the second the **independent variable**.

In example (a) above, h is the dependent and t the independent variable; in example (c) l is the dependent and θ the independent variable.

Note that it is always necessary to specify both variables before the meaning of the rate of increase can be understood.

For example, in cases (c) and (d) above, the dependent variable l , the length of a bar of zinc, is the same in both cases, but the rate of increase of its length l has a very different meaning, according as we mean the rate of increase $\frac{dl}{d\theta}$ with respect to the temperature of the bar when heated, or the rate of increase $\frac{dl}{dW}$ with respect to its tension when stretched.

In general, if y is the dependent and x the independent variable, the symbol $\frac{dy}{dx}$ denotes the rate of increase of y per unit increase of x .

EXAMPLES.—I.IV.

1. If $y = 12$ when $x = 5$, and $y = 17$ when $x = 7$, what is the mean value of $\frac{dy}{dx}$?

2. An electric tramcar passes one trolley pole at a certain instant, and the next trolley pole 8 seconds afterwards. The distance between the trolley poles is 120 ft. If s denotes the distance moved in time t , what is the mean value of $\frac{ds}{dt}$?

3. The speed v of a falling stone, after falling 2 seconds from rest, is 64.4 ft. per second. At $2\frac{1}{2}$ seconds from rest it is 80.5 ft. per second. If t denotes the time, find the value of the acceleration $\frac{dv}{dt}$.

4. If $y = 520$ when $x = 12$, and $y = 340$ when $x = 15$, what is the mean value of $\frac{dy}{dx}$?

5. When the volume v of a certain quantity of gas is 2 cu. ft. the pressure p is 60 lbs. per square inch. When the volume is 4 cu. ft. the pressure is 35 lbs. per square inch. Find the mean value of $\frac{dp}{dv}$.

6. The volume v of a certain quantity of gas at temperature $\theta = 17^\circ \text{C}$. is 341 cc. The volume at temperature 25°C . is 350.5 cc. What is the mean value of $\frac{dv}{d\theta}$?

7. The pressure p of saturated steam at temperature $\theta = 193.3^\circ \text{F}$. is 10 lbs. per square inch. At 197.8°F . the pressure is 11 lbs. per square inch. What is the mean value of $\frac{dp}{d\theta}$?

8. The unstretched length l of a wrought-iron bar is 10 ins. When it is subjected to a pull F of 3 tons, its length is 10.033 ins. What is the mean value of $\frac{dl}{dF}$ in inches per pound?

9. The current i in a conductor is 1.3 amperes when the time $t = 21.3$ secs. At time 33 secs. the current is 3.4 amperes. What is the mean value of $\frac{di}{dt}$?

10. When x is 42.1, we find from the tables that $\log_{10} x$ is 1.6243. When x is 42.2, $\log_{10} x$ is 1.6253. What is the mean value of $\frac{d(\log_{10} x)}{dx}$ between $x = 42.1$ and $x = 42.2$?

11. When $x = 0.3840$ radian, $\sin x = 0.3746$; when $x = 0.4014$ radian, $\sin x = 0.3907$. What is the mean value of $\frac{d(\sin x)}{dx}$ between $x = 0.3840$ and $x = 0.4014$?

12. When $x = 0.9076$ radian, $\cos x = 0.6157$; when $x = 0.9250$ radian, $\cos x = 0.6018$. What is the mean value of $\frac{d(\cos x)}{dx}$ in this interval?

91. Variable Rates of Increase.—In all the cases considered in the last paragraph we spoke of the **mean** value of the rate of increase throughout a definite interval. In the first case (a), for example, we found this by considering the growth in a whole year and treating it as if it were quite steady and uniform.

If, however, we consider this case more closely, we find that the rate of growth is not uniform throughout the year, it is not the same in winter, for instance, as it is in the summer. This is the reason why we called our previous result the **mean** value of the rate of growth $\frac{dh}{dt}$ for a year.

If we make very exact measurements from week to week we shall obtain results which will be nearer to the true value of the rate of growth $\frac{dh}{dt}$ at any time than the results which were obtained by taking the total growth in a year. Even these values, however, are only mean values for the respective weeks over which they are taken. It is supposed that the rate of growth is different at different times of the day and night, so that if we could consider the growth for periods of one hour we should get even nearer to the actual value of the rate of growth $\frac{dh}{dt}$ at any instant.

Thus we see that, as we consider smaller and smaller intervals, we get values of the mean rate of growth which are nearer and nearer to the actual rate of growth at some time within the intervals considered, and we can get as near as we please to this actual rate of growth by taking the interval small enough.

Another example of a variable rate of increase is afforded by the case (e) above.

The train travels a distance **AB** equal to 10 miles in 30 minutes, and we infer that its average speed throughout that half-hour, or the average value of $\frac{ds}{dt}$, is 20 miles an hour.

There may, however, be varying gradients between **A** and **B**, and the train may be brought to a stop at **B**, so that its actual speed will be sometimes greater and sometimes less than 20 miles an hour at different times between 1.50 and 2.20.

We shall evidently get a closer approximation to the actual speed at some particular time, say 2 o'clock, by measuring the distance travelled between 1.55 and 2.5 and dividing by the time taken, *i.e.* by 10 minutes expressed in hours.

We shall get even closer to the actual value of $\frac{ds}{dt}$ at 2 o'clock by finding the mean speed between 1.59 and 2.1, and closer still by finding the mean speed between 1 hr. - 59 mins. - 59 secs. and 2 hrs. - 0 min. - 1 sec., and so on. Thus we can get as near as we please to the actual speed at 2 o'clock by taking the interval of time small enough.

In mathematical language, we may say in general that the mean value of the rate of increase of y with respect to x , in all the cases which we shall consider, approaches a definite limiting value as the total increase of x considered is made smaller and smaller so as to include some definite value of x .

This limiting value defines the actual value of the rate of increase of y with respect to x for any particular value of x , and is denoted by the symbol $\frac{dy}{dx}$.

Thus in the case (a) above, the actual rate of growth $\frac{dh}{dt}$ at any age, say $5\frac{1}{2}$ years, may be defined as the limit of the average rate of growth taken over an interval including the age $5\frac{1}{2}$ years, when that interval is made smaller and smaller.

Similarly in case (e), the actual value of $\frac{ds}{dt}$ at 2 o'clock may be defined as the limit of the average velocity taken over an interval, including 2 o'clock when this interval is made smaller and smaller.

Q2. We may express the statements of the last paragraph as follows:—

If δx represents a definite increase in x and δy the corresponding increase in y , then $\frac{\delta y}{\delta x}$ is the mean value of $\frac{dy}{dx}$ throughout the interval δx .

As δx is made smaller and smaller, so as always to include some particular value of x , $\frac{\delta y}{\delta x}$ approaches a definite limiting value, which is the actual value of $\frac{dy}{dx}$ for that value of x . We can make $\frac{\delta y}{\delta x}$ as near as we please to the actual value of $\frac{dy}{dx}$ by taking δx small enough.

For example, in the case (a),

$$\begin{aligned} \text{when } \delta t &= 1 \text{ year between } 5 \text{ and } 6 \\ \delta h &= 44.00 - 41.03 = 2.97 \\ \text{and } \frac{\delta h}{\delta t} &= 2.97 \end{aligned}$$

This is the mean value of $\frac{dh}{dt}$ for the year between 5 and 6 years of age.

We saw that if δt were diminished, first to a week and then to an hour we should get values of $\frac{\delta h}{\delta t}$ which would continually approach the actual value of $\frac{dh}{dt}$ at some instant within the interval δt .

Similarly in the case (e), $\delta t = 30$ minutes = $\frac{1}{2}$ hour, $\delta s = 10$ miles, $\frac{\delta s}{\delta t} = \frac{10}{\frac{1}{2}} = 20$ miles per hour.

This is the mean value of $\frac{ds}{dt}$ for the half-hour from 1.50 to 2.20. To get the actual value of $\frac{ds}{dt}$ at 2 o'clock, we continually diminish δt , first to 10 minutes, then to 2 minutes, then to 2 seconds, and so on, so as always to include the instant 2 o'clock.

In some cases we find that the value of $\frac{\delta y}{\delta x}$ is the same, whatever value of δx is taken.

In case (d), for instance, it is found that, provided δW is not made too great, the value of $\frac{\delta l}{\delta W}$ is always the same, whatever value of δW is taken.

The rate of increase of the length with respect to the tension is therefore said to be **uniform**, and $\frac{\delta l}{\delta W}$ is equal to the actual value of $\frac{dl}{dW}$ for every value of W considered.

So also, in general, if $\frac{\delta y}{\delta x}$ is the same for all values of δx , the rate of increase of y with respect to x is said to be **uniform**, and $\frac{\delta y}{\delta x} = \frac{dy}{dx}$ for all values of x considered.

The cases considered in § 90 may be set down as follows :—

(a)

t years	h inches.	δh .	δt .	$\frac{\delta h}{\delta t}$.
12 . .	54'99}	. .	1'92 . .	1 . .
13 . .	56'91}	. .	1'92 . .	1'92 = mean value of $\frac{dh}{dt}$

(c)

θ C.	l inches.	δl .	$\delta \theta$.	$\frac{\delta l}{\delta \theta}$.
0 . .	10'00}	. .	0'03 . .	100 . .
100 . .	10'03}	. .	0'0003 . .	0'0003 = mean value of $\frac{dl}{d\theta}$

(e)

t hours.	s miles.	δs .	δt .	$\frac{\delta s}{\delta t}$.
$1\frac{5}{8}$	12}	10	0'5
$2\frac{1}{3}$	22}	10	20 = mean value of $\frac{ds}{dt}$

The student should state the other cases considered in the same way.

93. EXAMPLE (1).—The following values of s in feet show the distance of the centre of gravity (as measured in a skeleton drawing) of a piece of mechanism from some point in

its straight path at the time t seconds from some era of reckoning. Find its mean velocity during the interval between each pair of measurements.

(Board of Education Examination, 1901.)

s	t	δs	δt	$\frac{\delta s}{\delta t}$	
0'3090	2'00	0'1841	0'02	9'205	} Mean values of $\frac{\delta s}{\delta t}$ throughout each interval
0'4931	2'02	0'1868	0'02	9'34	
0'6799	2'04	0'1902	0'02	9'51	
0'8701	2'06	0'1942	0'02	9'71	
1'0643	2'08	0'1988	0'02	9'94	
1'2631	2'10				

By subtracting each value of s from the following value we obtain the values of δs in the third column. Similarly the values of δt in the fourth column are obtained by subtracting each value of t from the next value.

Then each value of δs represents the increase in s , or the distance moved during the corresponding interval of time δt . Therefore the mean *rate* of increase of s , or the mean velocity throughout each interval, is obtained by dividing each value of δs by the corresponding value of δt .

The results are placed in the fifth column. $\frac{\delta s}{\delta t}$ is always equal to the exact value of the velocity $\frac{ds}{dt}$ at some instant within the corresponding interval, and, if δt is small enough, we may take $\frac{\delta s}{\delta t}$ as an approximation to the actual velocity $\frac{ds}{dt}$ at the middle of the interval (see § 87).

Thus in the above example the velocity at time 2'05 secs. is 9'51 ft. per second.

EXAMPLE (2).—*To show that, with the data in example 1, the mean velocity $\frac{\delta s}{\delta t}$ approaches nearer and nearer to the actual velocity when $t = 2'05$, as the interval δt is taken smaller and smaller, so as always to include the instant when $t = 2'05$.*

We calculate the values of $\frac{\delta s}{\delta t}$, first for the interval between the first and sixth measurements, second for the interval between the second and fifth measurements, and so on. The calculations are given in the following table :—

δt	δs	$\frac{\delta s}{\delta t}$
0'10	0'9541	9'541
0'06	0'5712	9'520
0'02	0'1902	9'510

Thus we see that as the interval δt is made smaller and smaller the average velocity $\frac{\delta s}{\delta t}$ approaches nearer to the value 9'51, which we have taken as the velocity when $t = 2'05$.

EXAMPLE (3).—*In example 1 we have found a series of values of the velocity $\frac{ds}{dt} = v$. The acceleration is the rate of increase of the velocity with respect to the time. Find the mean acceleration between each pair of values of the velocity. What is the probable acceleration at time $t = 2'05$ seconds.*

We have from example 1—

t	v	δv	δt	$\frac{\delta v}{\delta t}$
2'00	—	—	—	$\left. \begin{array}{l} 6'75 \\ \text{—} \\ 8'5 \\ \text{—} \\ 10'0 \\ \text{—} \\ 11'5 \end{array} \right\} \begin{array}{l} \text{Mean value of} \\ \text{acceleration} \\ = \frac{dv}{dt} = \frac{d^2s}{dt^2} \\ \text{throughout} \\ \text{each interval} \end{array}$
2'01	9'205	—	—	
2'02	—	0'135	0'02	
2'03	9'34	—	—	
2'04	—	0'17	0'02	
2'05	9'51	—	—	
2'06	—	0'20	0'02	
2'07	9'71	—	—	
2'08	—	0'23	0'02	
2'09	9'94	—	—	
2'10	—	—	—	

As explained in example 1, we have taken the mean value of the velocity as found for each interval in example 1, as being equal to the exact value of the velocity at the middle of that interval.

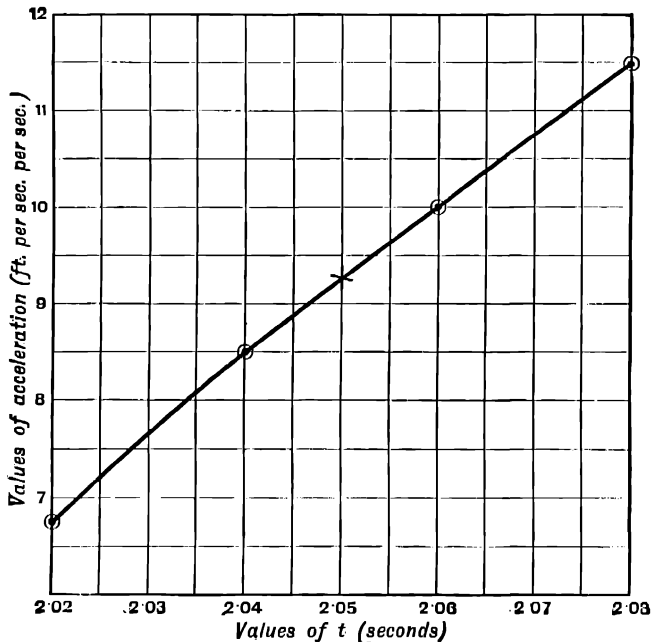

FIG. 81.

Thus the value 9'34 of the mean velocity found in example 1 for the interval between $t = 2'02$ and $t = 2'04$ has been taken as the actual velocity when $t = 2'03$.

Subtracting each value of v from the next, we obtain the values of δv given in the third column. Dividing by the value of δt , we obtain the value $\frac{\delta v}{\delta t}$ of the average

acceleration for each interval as given in the fifth column. As before, we have taken each value of the average acceleration to correspond to the middle of the corresponding interval of time. Thus we find that the mean acceleration between $t = 2.03$ and $t = 2.05$ is 8.5 . We take this as the actual acceleration when $t = 2.04$.

The acceleration when $t = 2.05$ is approximately equal to the mean of the values when $t = 2.04$ and $t = 2.06$, i.e. the acceleration for $t = 2.05$ is 9.25 .

A probably more accurate value may be obtained by the graphic method of interpolation described on p. 80.

Plotting the values of the acceleration and the time, we obtain the curve (Fig. 81). From the curve we find that the acceleration when $t = 2.05$ is 9.25 .

It may happen that the values of s and t are not given with sufficient accuracy to give values of the acceleration which will lie on a regular curve when plotted. In this case we could draw the regular curve which seems to represent the values of the acceleration best on the whole, and take intermediate values of the acceleration from this curve.

There are other more accurate methods of interpolation which the student is not yet in a position to understand, but the graphic method will usually be found to give values as accurate as the experimental results will allow.

94. The acceleration $\frac{d^2s}{dt^2}$ may also be written $\frac{d^2s}{dt^2}$. This denotes the result of performing the operation of finding the rate of increase with respect to t twice in succession.

Similarly, in the general case,

$\frac{dy}{dx}$ denotes the result of finding the rate of increase of y with respect to x .

$\frac{d^2y}{dx^2}$ denotes the result of finding the rate of increase of $\frac{dy}{dx}$ with respect to x .

$\frac{d^3y}{dx^3}$ denotes the result of finding the rate of increase of $\frac{d^2y}{dx^2}$ with respect to x .

95. Geometrical Representation.—If we take the two variables in any of the cases already considered as co-ordinates of a point, we may represent the rate of increase by a graphical method.

In case (a), p. 170, for instance, we may take values of the age t measured in years as abscissæ, and values of the height h measured in inches as ordinates.

Plot a point A (Fig. 82) whose abscissa is 5 and ordinate 41.03, and a point B whose abscissa is 6 and ordinate 44.00.

Then NB represents the increase in h which takes place, while t increases by the amount AN, or

$$NB = \delta h, AN = \delta t$$

Then the mean rate of increase of h with respect to t between $t = 5$ and $t = 6$ is

$$\frac{\delta h}{\delta t} = \frac{NB}{AN} = 2.97$$

This is the slope of the straight line AB to the axis of t when h and t are measured on the same scale, as in the figure.

If we measure NB and AN each on its proper scale, and use the numerical values obtained to find $\frac{NB}{AN}$, and if we agree to call this result the slope of

AB, we may still say that $\frac{\delta h}{\delta t}$ is the slope of **AB**, even if h and t are not plotted on the same scale.

Similarly, if in case (*b*) we plot points **A** and **B** with values of population as ordinates and values of time in years as abscissæ, the slope of **AB** will represent the mean rate of growth of population, *i.e.* the mean value of $\frac{dP}{dt}$ between 1881 and 1891.

We thus obtain the very important result that, if we are given two pairs

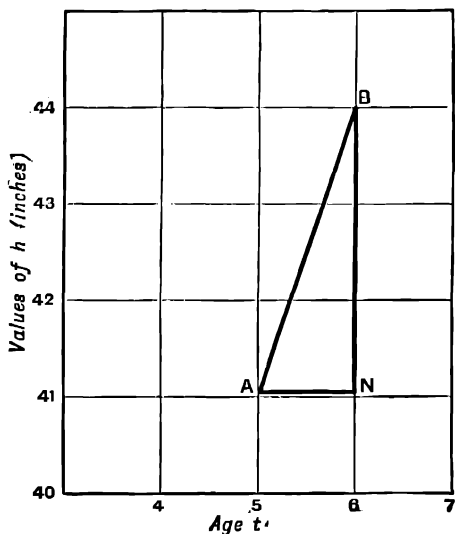

FIG. 82.

of corresponding values of the independent variable x and the dependent variable y , and plot two points to represent them, then the value of $\frac{\delta y}{\delta x}$, or the mean value of the rate of increase $\frac{dy}{dx}$, between **A** and **B** is the slope of **AB** to the axis of x .

The student should plot the cases given in Examples LIV., showing that the rate of increase in each case is given by the slope of a line.

86. Variable Rate of Increase—Geometrical Representation.—The following table gives the time taken by the projectile of a 38-ton gun to travel to various points throughout the first 8 ft. of the bore.

s feet, travel through bore	0	0·1	0·5	1·0	2·0	3·0	4·0
t seconds, time of travel	0·000	0·00143	0·00273	0·00360	0·00490	0·00598	0·00695

s	5.0	6.0	7.0	8.0
t	0.00785	0.00871	0.00953	0.01032

Taking values of s as ordinates and values of t as abscissæ, and plotting these values we obtain the curve **OCA** in Fig. 83.

While t increases from 0.00143 to 0.01032, s increases from 0.1 to 8.

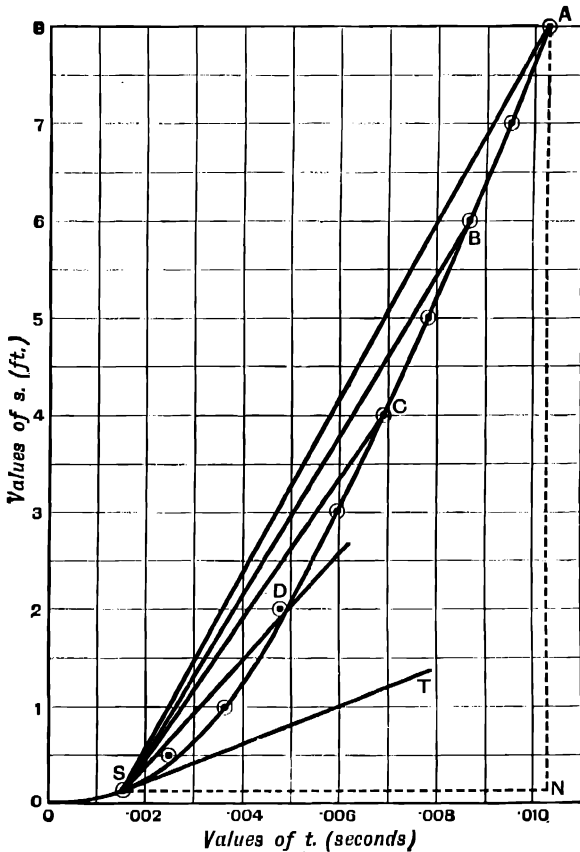

FIG. 83.

I.e. while δt is 0.00889, δs is 7.9, and the mean value of the velocity $\frac{ds}{dt}$ throughout the interval considered is $\frac{\delta s}{\delta t} = \frac{7.9}{0.00889} = 888$ ft. per second.

98. Rate of Decrease—Negative Rate of Increase.—It sometimes happens that, as the independent variable x becomes greater, the dependent variable y becomes less, so that the curve slopes downwards as x increases.

If, for example, we plot the pressure and volume of a given quantity of a gas at constant temperature (see Fig. 52), p decreases as v increases, i.e. δp is negative when δv is positive. The value of $\frac{\delta p}{\delta v}$ and therefore of $\frac{dp}{dv}$ is now negative, and the curve slopes downwards as v increases. Thus a negative value of $\frac{dy}{dx}$ denotes a rate of decrease, and is represented graphically by the case of a curve which slopes downwards to the axis of x as x increases.

98a. Interpolation Formula for Rate of Increase.—To find the value of $\frac{dy}{dx}$ from a table of values of y and x when the values of x are equidistant we may proceed as shown in the following example :—

x .	y .	δy .	$\delta^2 y$.	$\delta^3 y$.	$\delta^4 y$.	$\delta^5 y$.	δx .
110	1593						
115	1703	110	11				
120	1824	121	16	5			
125	1961	137	25	9	4	1	
130	2123	162	39	14	5	1	5
135	2324	201	59	20	6		
140	2584	260					

The column of second differences $\delta^2 y$ is obtained by subtracting each value of δy from the next, and so on.

Then the value of $\frac{dy}{dx}$ for $x = 125$ is given by the formula

$$\frac{dy}{dx} = \frac{1}{\delta x} \left(\delta_m y - \frac{1}{6} \delta^3_m y + \frac{1}{30} \delta^5_m y \right)$$

where $\delta_m y$ denotes the mean of the two values of δy lying immediately above and below a horizontal line through the value 125 of x .

Thus we have, as accurately as is possible from the number of values given above,

$$\begin{aligned} \frac{dy}{dx_{x=125}} &= \frac{1}{5} \left(\frac{137 + 162}{2} - \frac{1}{6} \cdot \frac{9 + 14}{2} + \frac{1}{30} \cdot \frac{1 + 1}{2} \right) \\ &= \frac{1}{5} (149.5 - 1.917 + 0.033) = 29.523. \end{aligned}$$

So also the value of $\frac{d^2 y}{dx^2}$ for $x = 125$ is given by $\frac{d^2 y}{dx^2} = \frac{1}{(\delta x)^2} \left(\delta^2 y - \frac{1}{12} \delta^4 y + \frac{1}{90} \delta^6 y \right)$

where $\delta^2 y = 25$ is the value on the horizontal line through the value 125 of x . The student is not yet in a position to follow the proof of these formulæ.

EXAMPLES.—LV.

1. Tabulate the mean values of $\frac{dy}{dx}$ for the intervals between each of the given values of x in the following. What is the value of $\frac{dy}{dx}$ when $x = 13.50$?

x	13.25	13.35	13.45	13.55	13.65
y	1.52	1.83	2.16	2.51	2.88

2. Tabulate the values of $\frac{dy}{dx}$ from the following. Plot curves showing the values of (a) y , (b) $\frac{dy}{dx}$, for any value of x throughout the above range.

x	16.75	17.27	17.76	18.22	18.65	19.05
y	3.41	3.43	3.45	3.47	3.49	3.51

What is the value of $\frac{dy}{dx}$ when $x = 17.99$?

3. s is the distance moved by a piece of mechanism in a straight line in time t . Tabulate the values of the velocity $\frac{ds}{dt}$.

s .	t .
0.4502	1.00
0.6218	1.02
0.7930	1.04
0.9639	1.06
1.1345	1.08
1.3048	1.10

4. Tabulate the values of the velocity from the following data. s and t have the same meaning as in the last example.

s .	t .
1.6762	1.02
1.3078	1.05
0.9386	1.08
0.5688	1.11
0.1983	1.14

5. If the chronograph records of the time at which a shot flying horizontally cuts three equidistant screens 150 ft. apart are 0.48907, 0.56331, 0.63865 seconds, find the velocity of the shot at the middle screen.

6. Tabulate the values of $\frac{d^2y}{dx^2}$ from the following values of x and y :—

x .	y .
781	152490
783	153272
785	154056
787	154842
789	155630
791	156420

7. Tabulate the values of $\frac{dy}{dx}$ and $\frac{d^2y}{dx^2}$ from the following corresponding values of y and x . What is the value of $\frac{d^2y}{dx^2}$ when $x = 7.2$?

Plot three curves showing the values of (a) y , (b) $\frac{dy}{dx}$, and (c) $\frac{d^2y}{dx^2}$, for every value of x . Verify by measurement that the slope of (a) is equal to the ordinate of (b), and that the slope of (b) is equal to the ordinate of (c).

x .	y .
6.8	11.431
7.0	11.957
7.2	12.567
7.4	13.305
7.6	14.215
7.8	15.341

8. From the following list of corresponding values of y and x , find the value of $\frac{d^2y}{dx^2}$ when $x = 4.0$:—

x .	y .
3.5	12.30100
3.7	13.37300
3.9	14.65024
4.1	16.13376
4.3	17.82476
4.5	19.72460

9. s feet is the distance moved in a straight line by a portion of a machine in time t seconds. Find its acceleration when $t = 3.04$. The force acting upon it is equal to its mass multiplied by its acceleration. Its weight is 400 lbs. The unit of mass is taken as 32.2 lbs. in order to obtain the force in pounds. Find the force acting upon it when $t = 3.04$.

t .	s .
3.02	1.2534
3.03	1.3859
3.04	1.5194
3.05	1.6540
3.06	1.7898

10. In the same way find the acceleration, when $t = 6.14$, from the following data :—

t seconds.	s feet.
6·12	4·2691
6·13	4·3992
6·14	4·5349
6·15	4·6765
6·16	4·8243

11. s gives the distance at time t of the piston of an engine from some fixed point on its stroke, as measured on a large scale drawing. Construct a table to show the velocity and acceleration at any time between 3·01 and 3·11 secs. Also plot two curves to show (a) the value of s at any time, (b) the velocity at any time, and verify by measurement that the ordinate of (b) is equal to the slope of (a).

t seconds.	s feet.
3·01	0·0065
3·03	0·0373
3·05	0·0922
3·07	0·1692
3·09	0·2663
3·11	0·3815

12. In the following table s is the distance in feet which the projectile of a gun travels along the bore in t seconds.

Make a table showing the velocity v and the acceleration a for different values of s from 0 to 14 ft.

Plot curves showing how v and a depend upon s assuming that each value of the speed corresponds to the middle point of the corresponding interval δs .

s feet.	t seconds.	s feet.	t seconds.
0·0	0·00000	7·0	0·00953
0·1	0·00143	8·0	0·01032
0·5	0·00273	9·0	0·01109
1·0	0·00360	10·0	0·01184
2·0	0·00490	11·0	0·01258
3·0	0·00598	12·0	0·01331
4·0	0·00695	13·0	0·01404
5·0	0·00785	14·0	0·01476
6·0	0·00871		

It will be found that the above values of s are not given with sufficient accuracy to obtain values of the acceleration lying exactly on a regular curve when plotted. Draw the curve representing the results best on the whole.

13. In the following table P is the population of England and Wales in millions as enumerated at each decennial census. Make a table showing the average rate of increase of population per annum throughout each ten years. Plot curves to show the connection (a) between the population and the time (b) between the rate of growth of population and the time.

Year . . .	1801	1811	1821	1831	1841	1851	1861	1871	1881	1891	1901
Population .	8'89	10'16	12'00	14'16	15'91	17'93	20'07	22'71	25'97	29'00	32'53

14. The table shows the average height of boys at different ages in Great Britain. Construct a table showing the average rate of growth in inches per annum for every year of age between 4 and 21. Plot two curves showing (a) the height at any age, (b) the rate of growth at any age.

Age (years) . .	4	5	6	7	8	9	10	11	12	13
Height (inches) .	38'46	41'03	44'00	45'97	47'05	49'70	51'84	53'50	54'99	56'91

Age (years) . . .	14	15	16	17	18	19	20	21
Height (inches) .	59'33	62'24	64'31	66'24	66'96	67'29	67'52	67'63

(British Association Report, 1883.)

15. The following table shows the average strength as measured by the drawing power of boys at different ages.

Make a table showing the rate of increase of strength per annum at all ages between 11 and 19. Plot two curves as in the last example.

Age (years) . .	11	12	13	14	15	16	17	18	19
Strength (lbs.) .	37'5	38'7	44'2	47'0	52'2	58'2	67'8	74'2	76'4

16. From the following data construct a table showing the rate of increase of weight of boys at any age between 10 and 20. Plot two curves as before.

Age . . .	10	11	12	13	14	15	16	17	18	19	20
Weight (lbs.)	67'5	72'0	76'7	82'6	92'0	102'7	119'0	130'9	137'4	139'6	143'3

17. The following is part of the record of a rough survey with a level.

A number of stations are fixed along a road, so that each station is 5 ft. higher than the one before it.

No. of station.	Distance to next station (yards).
1	30
2	70
3	27
4	20
5	23
6	35
7	30

The stations are in the same vertical plane.

Plot a curve to show the contour, *i.e.* the shape of a vertical section of the road between stations 1 and 7. Also plot a curve having as ordinate the slope of the road at any point, and as abscissa the distance along the road.

18. A body weighing 150 lbs. moves along a straight line, so that its velocity v at distance s from a fixed point on the line is given by the following table:—

s feet . . .	0	1	2	3	4	5
v ft. per second	5.2	6.5	10.4	16.9	26.0	37.7

The kinetic energy is equal to $\frac{1}{2}mv^2$, where m is the mass, and the force on the body is equal to the rate of increase of the kinetic energy with respect to the distance. Construct tables and plot curves showing the kinetic energy of the body and the force upon it throughout the above range of values of s .

19. ϕ is the entropy of 1 lb. of water at temperature t° F. Make a table to show the values of the mean rate of increase of ϕ per degree rise in temperature for the intervals between each of the given values of t .

t	200	210	220	230	240	250
ϕ	0.2949	0.3101	0.3251	0.3399	0.3545	0.3690

Plot a curve to show the value of $\frac{d\phi}{dt}$ throughout the above range of temperature.

20. p is the pressure in pounds per square inch of saturated steam at temperature θ° F.

Make a table showing the values of $\frac{dp}{d\theta}$ throughout the given range of temperature.

p	70	75	80	85	90	95	100	105	110	115
θ	302.7	307.4	311.8	316.0	320.0	323.9	327.6	331.1	334.5	337.8

Plot two curves showing the values of p and of $\frac{d^2p}{d\theta^2}$ for any value of θ throughout the above range.

21. The following are results of the experiments of Bartoli and Stracciati to find the specific heat of water. Q is the quantity of heat required to raise the temperature of 1 gm. of water from 0° C. to θ° C.

The specific heat s is the rate of increase of the quantity of heat per unit rise in temperature, i.e. $s = \frac{dQ}{dt}$. Construct a table and a curve to show the specific heat of water at any temperature throughout the above range. What is the specific heat at temperatures of 5° and 7° respectively?

θ .	Q .
3	3'01719
4	4'02180
5	5'02590
6	6'02946
7	7'03255
8	8'03512

22. From the tables make out a list of the values of $\frac{d(\sin \theta)}{d\theta}$ between $\theta = 0.7156$ radian and $\theta = 0.8378$ radian. Note that the value of $\frac{d(\sin \theta)}{d\theta}$ between any two values of θ is equal to some value of $\cos \theta$ between the same values of θ .

23. Make out a list of values of $\frac{d(\cos \theta)}{d\theta}$ between $\theta = 0.6981$ radian, and $\theta = 0.7854$ radian. Note that each is equal to a value of $-\sin \theta$ within the corresponding interval.

24. Make out a list of values of $\frac{d(\tan \theta)}{d\theta}$ from $\theta = 0.4363$ radian to $\theta = 0.5236$.

25. From the data given in Ex. XXXV. 14, plot a curve to show the rate of increase in the returns per £1 increase in the capital and labour expended for different values of the amount already invested in the farm, i.e. plot $\frac{dr}{dC}$ and C .

The farmer finds that he can get 5 per cent. for his money elsewhere with equal safety. How much will it be profitable to invest in the land?

NOTE.—As soon as $\frac{dr}{dC}$ becomes less than the rate of profit which he could obtain elsewhere, it is not worth his while to invest any more in the land.

CHAPTER XI

DIFFERENTIATION

99. Differential Coefficient of a Function.—We have shown how to find the rate of increase of y with respect to x from a list of corresponding values at small intervals.

If y is given as a function of x by means of an equation, we can calculate the value of δy corresponding to any value of δx from the equation, and thus obtain a formula for the rate of increase.

The process will be understood from the following example :—

EXAMPLE.—Let $y = 5x$ be the function whose rate of increase with respect to x we require to find.

If x increases by the amount δx , so as to become $x + \delta x$, y becomes

$$5(x + \delta x) = 5x + 5\delta x$$

\therefore if δy denotes the corresponding increase in y ,

$$y + \delta y = 5x + 5\delta x$$

$$\text{and since } y = 5x$$

$$\therefore \text{ subtracting, } \delta y = 5\delta x$$

$$\text{and } \frac{\delta y}{\delta x} = 5$$

Since this does not contain δx , it is unaltered when δx and δy are indefinitely diminished to obtain the limiting value $\frac{dy}{dx}$.

$$\therefore \frac{dy}{dx} = 5$$

The value of $\frac{dy}{dx}$ is called the **differential coefficient** of y with respect to x .

The process of finding $\frac{dy}{dx}$ is called **differentiating** y with respect to x .

If y is expressed as a function of x in the form $F(x)$, we may write its differential coefficient in the form $\frac{d}{dx}\{F(x)\}$, where the symbol $\frac{d}{dx}$ denotes the operation of differentiating with respect to x .

In the same way $\frac{d^2y}{dx^2}$ denotes the result of performing the operation $\frac{d}{dx}$ twice in succession upon the function y , and is called the **second differential coefficient** of y .

$\frac{d^ny}{dx^n}$ is called the n^{th} differential coefficient of y with respect to x , and denotes the result of performing the operation $\frac{d}{dx}$ n times in succession.

100. Geometrical Illustration.—Consider the geometrical meaning of the process in the above example.

The function $y = 5x$ is represented by the straight line OA , whose slope is 5.

Let OB be any value of x and BC the corresponding value of y . Then, if x is increased to OD , y increases to DE .

Thus, in the figure, $BD = CF = \delta x$ and $FE = \delta y$.

Thus $\frac{\delta y}{\delta x} = \frac{EF}{FC} = 5 = \text{slope of line } OA$.

This is the mean rate of increase of y from C to E .

For this case of the straight line it is evident that as D moves back to B , and F and E to C , the triangle EFC remains always the same shape, however small δx may be.

\therefore in the limit, as E moves to C , the value of $\frac{\delta y}{\delta x}$ remains equal to 5.

\therefore 5 is the value of the actual rate of increase of y at the point C or $\frac{dy}{dx} = 5$.

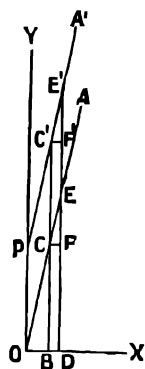

FIG. 84.

Note that for a straight line $\frac{\delta y}{\delta x}$ is the slope of the line, and is the same however large the interval CE is taken.

It follows that $\frac{dy}{dx}$ is the slope of the line, and is the same for all values of x .

The same method evidently applies to any equation $y = ax$ where a is a constant.

$$\therefore \text{ if } y = ax, \frac{dy}{dx} = a$$

Next consider a function of x , such as $5x + 2$. Here the line representing $y = 5x + 2$ is obtained from the straight line OA in the previous figure by increasing every value of y by 2; *i.e.* by moving the line parallel to itself upwards, through a distance of 2 units parallel to Oy .

We thus obtain the straight line PA' in the figure parallel to OA . If we proceed as before to find $\frac{dy}{dx}$, the triangle $E'F'C'$, from which we obtain

$\frac{\delta y}{\delta x}$ is equal in every respect to EFC .

$$\therefore \frac{\delta y}{\delta x} = \frac{E'F'}{F'C'} = 5 \text{ as before}$$

and $\therefore \frac{dy}{dx} = 5$ for every point on PA' as it is for every point on OA ; or, otherwise, since the slope of PA' is the same as the slope of OA , the value of $\frac{dy}{dx}$ must be the same, for

$$y = 5x + 2 \text{ and } y = 5x$$

So also, in general, the effect of adding a constant b to ax is simply to move the line $y = ax$ up through a distance b without altering its slope.

Thus $\frac{dy}{dx}$ is not altered, and it follows that

$$\frac{d}{dx}(ax + b) = \frac{d}{dx}(ax) = a$$

Similarly, it follows that the addition of a constant c to any function of x moves the whole curve upwards through a distance c , but does not alter the slope of the curve for any value of x .

Therefore the value of $\frac{dy}{dx}$ is not changed when y is increased by a constant, or

$$\frac{d}{dx}\{F(x) + c\} = \frac{d}{dx}\{F(x)\}$$

If y is a constant it does not change when x changes, and consequently its rate of increase is zero, or $\frac{dc}{dx} = 0$.

Geometrically, the equation $y = c$ represents a straight line parallel to the axis of x , and at a distance c from it, and the slope of this line is 0.

Note that if $y = ax + b$, then, since $\frac{dy}{dx} = a$, which is a constant, $\frac{d^2y}{dx^2}$ and all higher differential coefficients are zero.

EXAMPLES.—LVI.

Differentiate the following functions of x . Also plot the straight lines which represent them, and verify that in each case the slope of the line is equal to the differential coefficient.

1. $3x$.

2. $\frac{1}{2}x$.

3. $-2x$.

4. $-\frac{1}{4}x$.

5. $3x + 2$.

6. $4x - 3$.

7. $-3x + 1$.

8. $-0.6x + 2.1$.

9. $-0.13x - 2.5$.

10. $0.253x - 6.21$.

Find the values of —

11. $\frac{d}{dt}(at + b)$;

12. $\frac{d}{dz}(z - 3z)$;

13. $\frac{d}{dt}(\frac{1}{2}t - \frac{1}{4})$;

14. $\frac{d}{d\theta}(3 - 1.2\theta)$;

15. $\frac{d}{ds}(c - 3s)$;

16. $\frac{d}{du}(2u + 5)$;

where a , b , and c are constants.

17. If V_t is the volume at temperature $t^\circ\text{C}$. of a quantity of gas which occupies volume V_0 at 0°C ., and at the same pressure, then

$$V_t = V_0(1 + 0.00366t)$$

What is the rate of increase of the volume per degree rise in temperature? Illustrate by plotting V_t and t for the case $V_0 = 100$.

18. The current C amperes in a conductor of resistance R ohms, under an electro-motive force E volts, is given by $C = \frac{E}{R}$.

Find the rate of increase $\frac{dC}{dE}$ of the current with respect to the electro-motive force.

19. If we find by experiment that the speed v of a falling body and the time t from rest are connected by a straight line law; prove that the acceleration must be constant.

20. A point moves along a straight line so that its distance s from a fixed point on the line at time t is given by the equation

$$s = 1.3t + 2.6t^2$$

Find its velocity and acceleration.

21. The length l' of a stretched wire of unstretched length l is given by the formula

$$l' = l + \frac{lW}{AE}$$

where A and E are constants, and W is the stretching force. Find the rate at which the length increases per unit increase in the stretching force.

22. The length l of a copper cable at temperature $\theta^\circ \text{F}$ is given by the formula

$$l = 1560 \{1 + 0.0018(\theta - 32)\}$$

What is the rate of increase of its length per degree rise in temperature?

101. Differentiation of ax^2 .—Next consider the function $y = ax^2$.

Let x increase to $x + \delta x$.

Then the new value of y which we denote by

$$y + \delta y = a(x + \delta x)^2 = ax^2 + 2ax\delta x + a(\delta x)^2$$

Also we have $y = ax^2$.

We have here a pair of values of x and the corresponding values of y , and we proceed to find δy by subtraction, as in the previous paragraph.

\therefore subtracting

$$\delta y = 2ax\delta x + a(\delta x)^2$$

$$\therefore \frac{\delta y}{\delta x} = 2ax + a\delta x$$

In the limit when $\delta x = 0$ this becomes

$$\frac{dy}{dx} = 2ax$$

102. Geometrical Illustration.—We shall now illustrate the geometrical meaning of the above process as applied to the graphic representation of the equation $y = ax^2$.

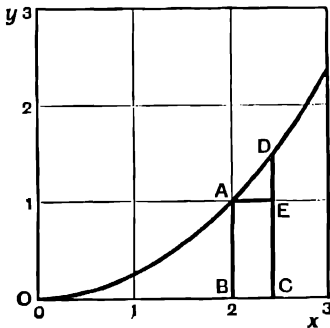

FIG. 85.

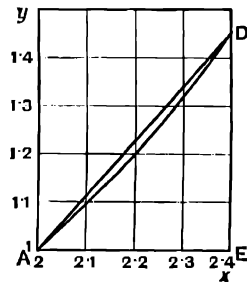

FIG. 86.

Take the case where $a = \frac{1}{4}$.
Plot the curve $y = \frac{1}{4}x^2$.

Consider the point **A** on the curve when $x = OB = 2$, and $y = BA = 1$.

Let x increase to $x + \delta x = OC = 2.4$, so that $\delta x = BC = 0.4$.

We thus get the point **D** on the curve, and if **AE** be drawn parallel to **OD**, $\delta y = ED = 0.44$.

Then the mean rate of increase of y with respect to x throughout the interval δx is

$$\frac{\delta y}{\delta x} = \frac{ED}{AE} = \frac{0.44}{0.4} = 1.1$$

This is equal to the slope of the line **AD**, and measures the mean slope of the curve from **A** to **D**.

As δx is diminished **C** moves back to **B**, and **E** and **D** to **A**, and $\frac{\delta y}{\delta x}$ approaches its limiting value $\frac{dy}{dx}$, which is equal to the slope of the tangent to the curve at **A**.

We find that

$$\begin{aligned} \text{when } \delta x = 0.3, \quad \frac{\delta y}{\delta x} &= \frac{0.3225}{0.3} = 1.075 \\ \text{,, } \delta x = 0.2, \quad \frac{\delta y}{\delta x} &= \frac{0.21}{0.2} = 1.05 \\ \text{,, } \delta x = 0.1, \quad \frac{\delta y}{\delta x} &= \frac{0.1025}{0.1} = 1.025 \\ \text{,, } \delta x = 0.05, \quad \frac{\delta y}{\delta x} &= \frac{0.0506}{0.05} = 1.0125 \\ \text{,, } \delta x = 0.01, \quad \frac{\delta y}{\delta x} &= \frac{0.010025}{0.01} = 1.0025 \end{aligned}$$

Thus $\frac{\delta y}{\delta x}$ may be made as near to the value 1 as we please by making δx sufficiently small, and is never less than 1.

\therefore the value of $\frac{dy}{dx}$ at **A**, which is the limit of $\frac{\delta y}{\delta x}$ as **C** approaches **B**, is equal to 1.

This agrees with the result of the last paragraph, where we found that, when $y = \frac{1}{4}x^2$, $\frac{dy}{dx} = 2 \times \frac{1}{4} \times x = \frac{x}{2}$, and when $x = OB = 2$ this becomes equal to 1.

103. Differentiation of ax^n .—The two cases $y = ax$ and $y = ax^2$ have been very fully treated to enable the student to get a clear idea of the method of obtaining a formula for the rate of increase of a function. These are special cases of the more general class $y = ax^n$.

We shall now find the rate of increase of ax^n .

$$\text{Let } y = x^n$$

$$\text{Then } y + \delta y = (x + \delta x)^n$$

$$= x^n + nx^{n-1}\delta x + \dots \text{ terms of higher degree in } \delta x \text{ (see § 45)}$$

\therefore subtracting

$$\delta y = nx^{n-1}\delta x + \text{ terms of higher degree in } \delta x$$

$$\therefore \frac{\delta y}{\delta x} = nx^{n-1} + \text{ terms containing } \delta x$$

In the limit when δx becomes indefinitely small, it can be proved that the sum of all the terms containing δx vanishes.

We thus get

$$\therefore \frac{dy}{dx} = nx^{n-1}, \text{ or } \frac{d}{dx}(x^n) = nx^{n-1}$$

In the same way, if a is any constant, it follows that

$$\frac{d}{dx}(ax^n) = nax^{n-1}$$

As before, the addition of a constant to the value of y does not affect the differential coefficient, or

$$\frac{d}{dx}(ax^n + b) = nax^{n-1} \text{ where } b \text{ is a constant}$$

EXAMPLE.—To verify numerically the above result for the differential coefficient of x^n for the case when $n = 3$.

By calculation we get the following values :—

x.	x ³ = y.	dy.	dx.	dy/dx.
1000·1	1000300030'001			
1000·2	1000600120'008	300090'007	0·1	3000900'07
1000·3	1000900270'027	300150'019	0·1	3001500'19

Mean of above values of $\frac{dy}{dx} = 3001200'13 = \text{probable value of } \frac{dy}{dx} \text{ for } x = 1000'2.$

By the rule proved above for differentiating x^n we get

$$\frac{dy}{dx} = 3x^2 = 3(1000'2)^2 = 3001200'12 \text{ for } x = 1000'2$$

This agrees with the numerical result obtained above to 8 significant figures.

The slight error in the second decimal place is due to the assumption that $\frac{dy}{dx}$ is exactly equal to the mean value of $\frac{dy}{dx}$ as found above.

EXAMPLES.—

(1.) If $y = 4x^3$, $\frac{dy}{dx} = 4 \times 3x^2 = 12x^2$.

(2.) If $y = \sqrt{x}$, $\frac{dy}{dx} = \frac{d}{dx}(x^{\frac{1}{2}}) = \frac{1}{2}x^{\frac{1}{2}-1} = \frac{1}{2}x^{-\frac{1}{2}} = \frac{1}{2\sqrt{x}}$.

(3.) $\frac{d}{du}(6u^{\frac{1}{2}}) = 6 \times \frac{1}{2}u^{-\frac{1}{2}} = \frac{3}{\sqrt{u}}$.

(4.) $\frac{d}{dx}\left(\frac{1}{x}\right) = \frac{d}{dx}(x^{-1}) = -1 \times x^{-2} = -\frac{1}{x^2}$.

(5.) $\frac{d}{dx}\left(\frac{1}{\sqrt{x}}\right) = \frac{d}{dx}(x^{-\frac{1}{2}}) = -\frac{1}{2}x^{-\frac{3}{2}} = -\frac{1}{2x\sqrt{x}}$.

(6.) $\frac{d}{dv}(v^{-1.32}) = -1.32v^{-2.32}$.

EXAMPLES.—LVII.

Write down the values of $\frac{dy}{dx}$ for the following cases :—

1. $y = x^2$. 2. $y = x^4$. 3. $y = (\sqrt{x})^3$. 4. $y = \frac{1}{x}$.
 5. $y = \frac{1}{x^2}$. 6. $y = x^{1.32}$. 7. $y = \frac{1}{x^{1.5}}$.

Find the value of the following :—

8. $\frac{d}{du} u^{1.28}$. 9. $\frac{d\sqrt{u}}{du}$. 10. $\frac{d}{dt}(5 \cdot 2t^3)$.
 11. $\frac{d}{ds}(s^{0.3})$. 12. $\frac{d}{dv}\left(\frac{576}{v^2}\right)$. 13. $\frac{d}{d\rho}\left(\frac{C}{\rho}\right)$ where C is a constant.
 14. $\frac{d}{dt}(at^2 + b)$ where a and b are constants.

104. To differentiate the Sum of a Number of Terms.

Let $y = u_1 + u_2 + u_3 \dots$ where $u_1, u_2, u_3 \dots$ are functions of x , which we can differentiate.

Let x increase to $x + \delta x$, $u_1, u_2, u_3 \dots$ to $u_1 + \delta u_1, u_2 + \delta u_2, u_3 + \delta u_3 \dots$ and y to $y + \delta y$.

$$\text{Then } \delta y = \delta u_1 + \delta u_2 + \delta u_3 + \dots$$

$$\text{and } \frac{\delta y}{\delta x} = \frac{\delta u_1}{\delta x} + \frac{\delta u_2}{\delta x} + \frac{\delta u_3}{\delta x} + \dots$$

and in the limit as δx and therefore $\delta u_1, \delta u_2 \dots$ and δy are indefinitely diminished,

$$\frac{dy}{dx} = \frac{du_1}{dx} + \frac{du_2}{dx} + \frac{du_3}{dx} + \dots$$

\therefore the differential coefficient of the sum of a number of terms is equal to the sum of their differential coefficients, or the sum of a number of terms can be differentiated term by term.

EXAMPLES.—

- (1.) $\frac{d}{dx}(3x - 5x^2 + 6x^3 + 8x^4) = 3 - 10x + 18x^2 + 32x^3$.
 (2.) $\frac{d}{ds}(5 \cdot 3 - 6 \cdot 2 s^{1.5} + 2s^2) = -6 \cdot 2 \times 1 \cdot 5 s^{0.5} + 4s$
 $= -9 \cdot 3 s^{0.5} + 4s$.

105. Velocity and Acceleration.

EXAMPLE.—A point moves along a straight line so that its distance s feet from some fixed point on the line at time t seconds from some definite instant is given by the formula

$$s = 4t^2 - 5t + 3$$

Find expressions for its velocity and acceleration at any time. Calculate the velocity at time 5 seconds.

We have

$$\text{velocity} = \frac{ds}{dt} = 8t - 5$$

∴ velocity when $t = 5$ is $40 - 5 = 35$ ft. per second

To find the acceleration we have, if v be the velocity at time t ,

acceleration = rate of increase of velocity with respect to time

$$= \frac{dv}{dt}$$

and since $v = 8t - 5$

$$\frac{dv}{dt} = 8$$

i.e. the acceleration is constant, and equal to 8 ft. per second per second.

100. EXAMPLE.—If the pressure and volume of a gas are connected by the relation $p v^\gamma = C$, where γ and C are constants, find the volumetric elasticity $e_v = -v \frac{dp}{dv}$.

We have

$$p v^\gamma = C, \text{ and } \therefore p = C v^{-\gamma}$$

$$\therefore e_v = -v \frac{dp}{dv} = -v(-\gamma \cdot C v^{-\gamma-1}) = v\gamma \frac{C v^{-\gamma}}{v} = \gamma \cdot C v^{-\gamma} = \gamma p.$$

EXAMPLES.—I.VIII.

Differentiate with respect to x .

- | | |
|---|-------------------------------|
| 1. $3x^2 - 2x + 1.$ | 2. $2 - 5x - 6x^2.$ |
| 3. $4x^6 - 3x^3 + 7x^4 - x^3 + 2x^2 - x - 3.$ | |
| 4. $3x^2 - 21x^4 + 6x^3 - x.$ | 5. $3x^3 - 2x^2 + x^5 - x^9.$ |

Find the value of the following :—

- | | |
|---|---|
| 6. $\frac{d}{dt}(3 + 5t + 6t^2).$ | |
| 7. $\frac{d}{dt}(a + bt + ct^2)$ where $a, b,$ and c are constants. | |
| 8. $\frac{d}{dx}\left(x^3 - \frac{a}{bx^2} + C\right).$ | 9. $\frac{d}{dx}(1 \cdot 3x^{1.21} - 2x^{2.3} + 3x^{4.6} - x).$ |
| 10. $\frac{d}{dx}\left(\frac{1 \cdot 3}{x^{2.1}} - 2\sqrt{x} - 2 \cdot 5x^{-\frac{3}{2}}\right).$ | 11. $\frac{d}{dx}\left(3x^{1.3} - 7x^{-3.6} + \sqrt{\frac{5}{x}} - \frac{6}{x^{2.3}}\right).$ |
| 12. $\frac{d}{dx}(x^{2.5} - x^{1.36} + 3x^{2.9} - x^{0.013} + 2 \cdot 1).$ | |
| 13. $\frac{d}{dx}\left(x^{1.9} - \frac{1}{x^{2.6}} + x^7 - \frac{1}{x^3} + 3\right).$ | 14. $\frac{d}{du}\left(u^{1.5} - \frac{2}{u^{2.3}} + \frac{1}{2\sqrt{u}} - 6\right).$ |
| 15. $\frac{d}{du}\left(\sqrt{u} + \frac{1}{u} + u + 1\right).$ | 16. $\frac{d}{dx}\left(x^{1.7} - \frac{1}{x^{0.3}} + 2x^{3.5}\right).$ |
| 17. $\frac{d}{dx}\left(\sqrt{x} + \frac{1}{2\sqrt{x}} - \frac{x^3}{\sqrt{x}}\right).$ | 18. $\frac{d}{dx}\left(\frac{1}{x^4} - \frac{x^4}{x^3} + \frac{3}{x^3} - \frac{2}{x}\right).$ |
| 19. $\frac{d}{dx}\left(3x^2 - 3x + \frac{1}{\sqrt[3]{x}} - \frac{1}{\sqrt[3]{x}}\right).$ | 20. $\frac{d}{ds}(s^3 - 3s^3 + 4 + \sqrt[3]{s}).$ |
| 21. $\frac{d^2}{dt^2}\left(t^3 - \frac{1}{t^2} - \frac{2}{t} + 3 + \sqrt{2t}\right).$ | 22. $\frac{d}{dv}\left(v^{-2.364} + \frac{1}{v^{2.721}} - 3v^3 + 18\right).$ |

$$23. \frac{d}{dz} \frac{x^3 - 3z^2 + 2z - 5}{z^2} \qquad 24. \frac{d}{dx} \frac{x^{17} + 2x^{27} - x^{61} + 15}{x^{15}}$$

$$25. \frac{d}{du} \left(\frac{479}{u^{1.0646}} \right) \qquad 26. \frac{d}{dv} \left(\frac{k}{v} \right) \text{ and } \frac{d}{dp} \left(\frac{k}{p} \right) \qquad 27. \frac{d}{dp} \left(\frac{479}{p} \right)^{\frac{1}{1.0646}}$$

28. Find the 1st, 2nd, 3rd, 4th, and 5th differential coefficients of x^3 .

29. Show that $\frac{d^n}{dx^n} (x^n)$ is a constant, and that any higher differential coefficient is zero.

30. From the following data verify the rule for differentiating x^2 :—

x .	x^2 .
966	933156
967	935089
968	937024
969	938961

31. Calculate the values of $3x^2$ when x has the values 121.1, 121.2, 121.3, and thence verify numerically the rule for differentiating ax^u for the case when $a = 3$, $u = 2$.

32. Verify the rule for differentiating \sqrt{x} from the following :—

x .	\sqrt{x} .
966	31.081
967	31.097
968	31.113
969	31.129

33. Verify the rule for differentiating \sqrt{x} from the following :—

x .	\sqrt{x} .
406	20.1494
410	20.2485
414	20.3470
418	20.4450

Plot two curves showing (a) the value of \sqrt{x} for any value of x , (b) the value of $\frac{d\sqrt{x}}{dx}$ for any value of x . Verify by measurement that the ordinate of (b) is equal to the slope of (a).

34. From the following numbers tabulate the values of $\frac{dy}{dx}$, and compare with the result of differentiating $\frac{1}{x}$. Plot curves showing the values of y and $\frac{dy}{dx}$ for any value of x within this range.

x .	$y = \frac{1}{x}$
8·81	0·11351
8·82	0·11338
8·83	0·11325
8·84	0·11312
8·85	0·11299
8·86	0·11287

Plot two curves showing (a) the value of y , (b) the value of $\frac{dy}{dx}$ for any value of x within the given range.

35. Do the same for $y = x^{\frac{3}{2}}$ having the following values given :—

x .	$y = x^{\frac{3}{2}}$.
91	20·231
92	20·379
93	20·527
94	20·674

36. Calculate the values of x^3 for the cases when $x = 1000, 1001, \text{ and } 1002$. From your results find the mean rate of increase of x^3 between each successive pair of the above values of x , and compare with the result of differentiating x^3 .

37. Calculate the values of $\frac{1}{x^2}$ for the cases $x = 1000, 1001, \text{ and } 1002$ respectively, and, as above, find the rate of increase of $\frac{1}{x^2}$ for the given intervals, and compare with the result obtained by differentiation.

In the four following examples the curves should be drawn on a large scale between the given values :—

38. Draw the curve $y = x^2 - 3x + 2$ from $x = 2\cdot8$ to $x = 3\cdot2$, and measure its slope at the point where $x = 3$. Compare this value with the value of $\frac{dy}{dx}$ obtained by differentiation.

NOTE.—This and the following examples will serve to give the student an idea of the accuracy which he can attain in measuring the slope of a curve.

39. Draw the curve $y = 2 + 2x - x^2$ from $x = 1\cdot8$ to $x = 2\cdot2$. Find its slope at $x = 2$, and compare with the value of $\frac{dy}{dx}$ obtained by differentiation.

40. Draw the curve $y = x - \frac{1}{x}$ from $x = 0\cdot9$ to $x = 1\cdot1$. Find its slope at $x = 1$, and compare with the value of $\frac{dy}{dx}$ obtained by differentiation.

41. Draw the curve $y = x^{-3\cdot2} + 2x^{1\cdot6}$ from $x = 0\cdot9$ to $x = 1\cdot1$. Find its slope at $x = 1$, and compare with the value of $\frac{dy}{dx}$ obtained by differentiation.

42. If a point moves along a straight line so that its distance s feet from one end at time t seconds always satisfies the equation $s = 3\cdot1 - 5t + 6t^2$, find its velocity and acceleration at the end of 5 seconds.

43. Similarly, if $s = \frac{1}{2}t^2$, find the velocity and acceleration at the end of 6 seconds.

Plot curves showing the values of (a) the distance moved, (b) the velocity, (c) the acceleration, at any time from $t = 1$ to $t = 7$.

44. The distance s feet travelled by a falling body from rest in time t seconds, neglecting the resistance of the air, is given approximately by the formula $s = 16 \cdot 1t^2$. Find an expression for its speed at any time. Plot the curve $s = 16 \cdot 1t^2$, and by measuring its slope to the axis of t at the points $t = 1, t = 2, t = 3, t = 4$, obtain the velocity after falling 1, 2, 3 and 4 seconds respectively. Compare with the values found by differentiation. Also find the acceleration.

45. The distance s feet fallen by a stone in t seconds is given by $s = 16 \cdot 1t^2 - 200t + 5$. Find expressions for the velocity and acceleration at any time.

46. A point moves in a straight line, so that its distance from a fixed point on the line at time t is given by the formula $s = a + bt + ct^2$. Find formulæ for its velocity and acceleration at any time.

47. A mass of 200 units moves along a straight line, so that its distance s from a fixed point on the line at time t is given by the equation

$$s = 1 \cdot 3 + 2 \cdot 5t + 4 \cdot 2t^2$$

Let v be its velocity. Then its kinetic energy is $\frac{1}{2}mv^2$, and its momentum is mv , where m is the mass. Find expressions for its kinetic energy and momentum at any time.

48. The pressure and volume of a gas at constant temperature are connected by the equation $p\nu = C$. Find an expression for the rate of increase of the pressure with respect to the volume. Plot the curve $p\nu = 1$, and verify your result by measuring its slope at the point where $\nu = 1$.

49. The volumetric elasticity of a fluid is equal to $e = -\nu \frac{dp}{d\nu}$. If a gas expands at constant temperature, so as to obey the law $p\nu = C$, find an expression for the volumetric elasticity e , and show that $e = p$.

50. It was found from Regnault's experiments that the total heat Q required to raise the temperature of 1 gram. of water from 0° C. to θ° C. between $\theta = 0$ and $\theta = 200$ is given by the equation

$$Q = \theta + 2 \times 10^{-3} \cdot \theta^2 + 3 \times 10^{-7} \theta^3$$

The specific heat at temperature θ is the rate of increase of the quantity of heat per unit rise in temperature. Find a formula for the specific heat s of water at any temperature.

51. It was found by Weber that the quantity Q of heat required to raise the temperature of unit mass of diamond from 0° C. to θ° C. was given by the equation

$$Q = 0 \cdot 0947\theta + 0 \cdot 000497\theta^2 - 0 \cdot 00000012\theta^3$$

Find a formula for the specific heat s at any temperature, and plot curves to show the values of s and Q for all values of θ between 0° and 200° .

52. This and the following examples refer to beams loaded in various ways (see pp. 97, 102). y is the deflection at a distance x from a fixed point on the beam. W , w , l , I , and E are constant.

$$y = \frac{W}{EI} \left(\frac{1}{2}lx^2 - \frac{1}{6}x^3 \right)$$

$$\text{find } \frac{dy}{dx}, \frac{d^2y}{dx^2}, \text{ and } \frac{d^3y}{dx^3}$$

53.

$$y = \frac{w}{24EI} (6l^2x^2 - 4lx^3 + x^4)$$

$$\text{find } \frac{dy}{dx}, \frac{d^2y}{dx^2}, \frac{d^3y}{dx^3}, \frac{d^4y}{dx^4}$$

54.

$$y = \frac{w}{48EI} (3l^2x^2 - 2x^4)$$

$$\text{find } \frac{dy}{dx}, \frac{d^2y}{dx^2}, \frac{d^3y}{dx^3}, \frac{d^4y}{dx^4}$$

107. Differentiation of e^x .

If e is defined as in § 7, it can be shown that

$$e^x = 1 + x + \frac{x^2}{1 \cdot 2} + \frac{x^3}{1 \cdot 2 \cdot 3} + \frac{x^4}{1 \cdot 2 \cdot 3 \cdot 4} + \dots$$

where the sum of the series continually approaches a definite limiting value as the number of terms is indefinitely increased.

It can be shown that such a series can be differentiated term by term, and that the result is the differential coefficient of the sum.

Differentiating term by term, we find that

$$\begin{aligned} \frac{d}{dx}(e^x) &= 0 + 1 + \frac{2 \cdot x}{1 \cdot 2} + \frac{3x^2}{1 \cdot 2 \cdot 3} + \frac{4x^3}{1 \cdot 2 \cdot 3 \cdot 4} + \dots \\ &= 1 + x + \frac{x^2}{1 \cdot 2} + \frac{x^3}{1 \cdot 2 \cdot 3} + \frac{x^4}{1 \cdot 2 \cdot 3 \cdot 4} + \dots \\ &= e^x \end{aligned}$$

Thus e^x is a function whose rate of increase with respect to x is equal to the function itself.

This result shows that if we plot the curve $y = e^x$ the slope of the curve at any point is equal to the ordinate at that point.

EXAMPLE (1).—Plot the curve $y = e^x$ from $x = 0$ to $x = 2$, measure its slope at the points where $x = 0.5, 1, 1.5$, and compare with the values of y .

EXAMPLE (2).—Plot the curve $y = e^x$ on a large scale from $x = 0.99$ to $x = 1.01$, and measure its slope at the point $x = 1$.

The differential coefficient of ae^{bx} may be obtained in the same way. We have

$$ae^{bx} = a + abx + a \frac{b^2x^2}{1 \cdot 2} + a \frac{b^3x^3}{1 \cdot 2 \cdot 3} + \dots$$

Differentiating term by term, we get

$$\frac{d}{dx}(ae^{bx}) = ab + ab \cdot bx + ab \frac{b^2x^2}{1 \cdot 2} + \dots$$

Note that the rate of increase of ae^{bx} is proportional to the function ae^{bx} itself.

EXAMPLES.—

(1.) $\frac{d}{dx}(3e^{4x}) = 12e^{4x}$

(2.) $\frac{d}{dx}\left(\frac{3}{e^{2x}}\right) = \frac{d}{dx}(3e^{-2x}) = -6e^{-2x}$

(3.) $\frac{d}{dx}(\sqrt{e^x}) = \frac{d}{dx}e^{\frac{1}{2}x} = \frac{1}{2}e^{\frac{1}{2}x}$.

We may extend this method to the differentiation of a^x ; for, by the definition of a logarithm,

$$a = e^{\log_e a} \text{ and } \therefore a^x = e^{x \cdot \log_e a}$$

$$\therefore \frac{d}{dx}(a^x) = (\log_e a)e^{x(\log_e a)} = a^x \cdot \log_e a$$

EXAMPLE.—

$$\begin{aligned}\frac{d}{dx}(2.1)^x &= 2.1^x \cdot \log_e 2.1. \\ &= 0.742 \times 2.1^x.\end{aligned}$$

EXAMPLES.—LIX.

1. Plot the curve $y = e^{2x}$ from $x = -1$ to $x = +1$; then by the result just proved the slope of this curve at any point should be equal to $\frac{d}{dx}(e^{2x}) = 2e^{2x} = 2y$. Verify this by measuring the slope at the points $x = -0.5$, $x = 0.25$, and $x = 0.7$.

2. Tabulate the values of $\frac{dy}{dx}$ from the data given in the following table. Note that in each case the value of $\frac{dy}{dx}$ is equal to some value of y within the corresponding interval.

x .	$e^x = y$.
1.50	4.48169
1.51	4.52673
1.52	4.57223
1.53	4.61818
1.54	4.66459

Find the value of—

3. $\frac{d}{dx}(26e^{1.3x})$.

4. $\frac{d}{dx}(4.2e^{-3.1x})$.

5. $\frac{d}{dx}\left(\frac{32}{e^{1.5x}}\right)$.

6. $\frac{d}{dt}(1.6e^{-2.5t})$.

7. $\frac{d}{du}(e^{1.3u} + 5)$.

8. $\frac{d}{du}(e^{1.3u + 5})$.

9. $\frac{d}{dx}\{3.7e^{1.2} - 2e^{0.2x} + 3.1x^{5.2}\}$.

10. $\frac{d}{du}\{ae^{-bu} + ce^{2bu} - 3e^{bu}\}$.

 a , b , and c are constants.

11. $\frac{d}{dx}\{x^{1.3} - 2.6x^{4.2} + 5.1e^{-2x} - 3e^{5.1}\}$.

12. If $\sinh x = \frac{e^x - e^{-x}}{2}$, and $\cosh x = \frac{e^x + e^{-x}}{2}$, show that $\frac{d}{dx}(\sinh x) = \cosh x$, and

$\frac{d}{dx}(\cosh x) = \sinh x$.

13. $\frac{d}{dx}(4.81)^{2x}$.

14. $\frac{d}{dx}(2.3)^{2x}$.

15. $\frac{d}{dt}(2.85)^t$.

16. $\frac{d^2}{dt^2}(2.5)^t$.

17. $\frac{d^2}{dx^2}(e^x)$, $\frac{d^2}{dx^2}(e^{3x})$, $\frac{d^2}{dx^2}(e^{ax})$.

18. If $s = 7e^{-3t} + 5e^{2t}$, prove that $\frac{d^2s}{dt^2} = 9s$.

19. If $y = ae^{2x}$, find the value of $\frac{d^2y}{dx^2} - b^2y$.

20. If $y = Ae^{2x} + Be^{3x}$, find the value of $\frac{d^2y}{dx^2} - 5\frac{dy}{dx} + 6y$.

21. If $y = Ae^{-a_1x} + Be^{-a_2x}$, find the values of C and D so that

$\frac{d^2y}{dx^2} + C\frac{dy}{dx} + Dy$ may be equal to 0 for all values of x .

22. If $v = Ae^{\lambda_1 t} + Be^{\lambda_2 t}$ where λ_1, λ_2 are the roots of the quadratic equation in λ

$$L\lambda^2 + R\lambda + \frac{1}{K} = 0,$$

prove that $L \frac{d^2 v}{dt^2} + R \frac{dv}{dt} + \frac{v}{K} = 0$.

23. If a body is heated to a temperature θ_1° and then allowed to cool by radiation, its temperature at time t seconds is given by the equation $\theta = \theta_1 e^{-at}$ where a is a constant. Prove that the rate of cooling in degrees per second is proportional to the temperature.

24. If V is the difference of potential at time t between the plates of a condenser discharging through a resistance R , it can be shown that $\frac{dV}{dt} = -\frac{V}{KR}$. Show that

this equation is satisfied if $V = V_0 e^{-\frac{t}{KR}}$ where V_0 is constant. What is the value of V when $t = 0$?

108. Differentiation of $\sin x$.

Let $y = \sin x$ where x is measured in radians.

Let x increase to $x + \delta x$, and y to $y + \delta y$.

$$\begin{aligned} \text{Then } y + \delta y &= \sin(x + \delta x) \\ \therefore \delta y &= \sin(x + \delta x) - \sin x \\ &= 2 \cos\left(x + \frac{\delta x}{2}\right) \sin \frac{\delta x}{2} \end{aligned}$$

\therefore mean rate of increase of y is

$$\begin{aligned} \frac{\delta y}{\delta x} &= 2 \cos\left(x + \frac{\delta x}{2}\right) \frac{\sin \frac{\delta x}{2}}{\delta x} \\ &= \cos\left(x + \frac{\delta x}{2}\right) \frac{\sin \frac{\delta x}{2}}{\frac{\delta x}{2}} \end{aligned}$$

We notice from the tables that as the angle $\frac{\delta x}{2}$ is made smaller and smaller the values of $\sin \frac{\delta x}{2}$ and of $\frac{\delta x}{2}$ become more and more nearly equal.

It may be rigorously proved that the fraction $\frac{\sin \frac{\delta x}{2}}{\frac{\delta x}{2}}$ becomes equal to 1

in the limit, as the angle $\frac{\delta x}{2}$ is indefinitely diminished.

$$\therefore \frac{dy}{dx} = \left(\text{limit of } \frac{\delta y}{\delta x} \text{ when } \delta x = 0\right) = \cos x$$

109. Differentiation of $\cos x$.

Let $y = \cos x$.

Let x increase to $x + \delta x$, and y to $y + \delta y$.

$$\begin{aligned} \text{Then } y + \delta y &= \cos(x + \delta x) \\ \delta y &= \cos(x + \delta x) - \cos x \\ &= -2 \sin\left(x + \frac{\delta x}{2}\right) \sin \frac{\delta x}{2} \\ \frac{\delta y}{\delta x} &= -\sin\left(x + \frac{\delta x}{2}\right) \frac{\sin \frac{\delta x}{2}}{\frac{\delta x}{2}} \end{aligned}$$

In the limit, as $\cos \delta x$ vanishes, this becomes

$$\frac{dy}{dx} = -\sin x$$

This result may also be obtained from the previous one by writing $x + \frac{\pi}{2}$ for x .

110. EXAMPLE.—To verify from the tables that $\frac{d}{dx}(\sin x) = \cos x$.

We have.

	$y = \sin x$.	δy .	δx .	$\frac{\delta y}{\delta x}$.	Mean value of $\frac{dy}{dx}$.
$23^\circ 0'$	0'3907311	0'0002669	} $1' = 0'0002909$ radian	0'9177	} 0'9205
$23^\circ 1'$	0'3909980	0'0002686		0'9234	
$23^\circ 2'$	0'3912666				

$\frac{\delta y}{\delta x}$ is equal to the mean value of $\frac{dy}{dx}$ throughout each interval of $1'$ for which it is measured, and the mean of the two values of $\frac{\delta y}{\delta x}$ is approximately equal to the value of $\frac{dy}{dx}$ when $x = 23^\circ 1'$.

From the tables we find that the value of $\cos 23^\circ 1'$ is 0'9204.

$\therefore \frac{d}{dx}(\sin x) = \cos x$ for the value $x = 23^\circ 1'$ within the limits of accuracy of the above method.

NOTE.— δx must be expressed in radians because, in proving that $\frac{d}{dx}(\sin x) = \cos x$, it is assumed that x is measured in radians.

111. Geometrical Illustration.—Plot the curves $y = \sin x$, **ABC**, and $y = \cos x$, **A'B'C'**, measuring x in radians.

Then the result of § 108 shows that the slope of the sine curve at any point **P** is given by the corresponding ordinate **NP'** of the cosine curve.

In particular, the slope of the sine curve at **A** is equal to **AA'** or unity. Note, however, that the slope is measured as in § 95.

From **A** to **B** the sine curve becomes less and less steep, until at **B** the

slope is zero, corresponding to the point B' where the cosine curve cuts the axis of x .

From B to C the sine curve slopes downwards and increases in steepness;

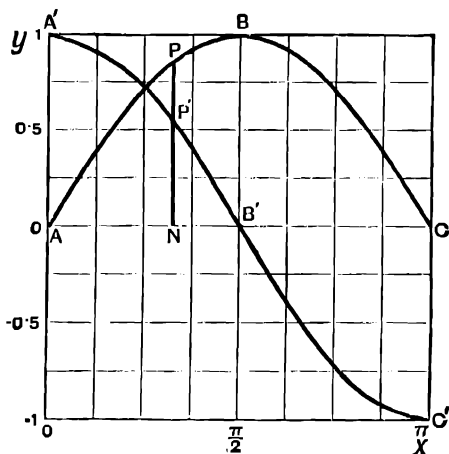

FIG. 87.

until at C its slope is -1 , corresponding to the point C' on the cosine curve, and so on.

If we consider the slope of the cosine curve we see that, since the curve slopes downwards from A' to B' , $\frac{dy}{dx}$ must be negative, and pass from 0 at A to -1 at B' as the ordinate of the sine curve changes from 0 at A to $+1$ at B .

This agrees with the result $\frac{d}{dx}(\cos x) = -\sin x$, and gives a geometrical explanation of the minus sign.

112. By a similar method to that used to differentiate $\sin x$ and $\cos x$ we may show that

$$\frac{d}{dx}\{a \sin (bx + c)\} = ab \cos (bx + c)$$

$$\frac{d}{dx}\{a \cos (bx + c)\} = -ab \sin (bx + c)$$

Thus

$$\frac{d}{dx} \sin 2x = 2 \cos 2x$$

$$\frac{d}{dx} \sin (2x + 1) = 2 \cos (2x + 1)$$

$$\frac{d}{dx} 3 \sin (2x + 1) = 6 \cos (2x + 1)$$

$$\frac{d}{dx} \sin (1 - x) = -\cos (1 - x)$$

$$\frac{d}{dx} \cos 4x = -4 \sin 4x$$

$$\frac{d}{dx} 2 \cos (5x - 2) = -10 \sin (5x - 2)$$

$$\frac{d}{dx} \cos (3 - 4x) = 4 \sin (3 - 4x)$$

EXAMPLES.—LX.

Differentiate the following with respect to x :—

1. $\sin 3x$. 2. $\cos 2x$. 3. $\sin \frac{1}{2}x$. 4. $\cos \frac{x}{5}$.
 5. $\cos (-3x)$. 6. $3 \sin (-\frac{1}{3}x)$. 7. $4 \cos (-2.35x)$.
 8. $2 \sin (2x - 4)$. 9. $-3 \cos (2 + 3x)$. 10. $5 \sin (2.5 + 3.1x)$.
 11. $-2 \cos (1 - 3x)$. 12. $6 \sin (2 - 5x)$. 13. $\frac{1}{25} \cos (\frac{1}{3} - \frac{1}{4}x)$.
 14. $1.002 \sin (0.351x + 0.273)$. 15. $2.56 \cos (3.71 - 1.52x)$.

Find the value of the following :—

16. $\frac{d}{dt} a \sin (nt + \epsilon)$. 17. $\frac{d}{dt} A \sin (pt + a)$. 18. $\frac{d}{dt} A \cos (pt + a)$.
 19. $\frac{d}{dt} \{A \sin (ct + a) + B \sin (ct - a)\}$. 20. $\frac{d}{dt} A \sin (\theta + c)$.
 21. $\frac{d}{dt} 3 \sin (1.03t + 2.5t)$. 22. $\frac{d}{dt} \sin (2\pi ft + g)$.

23. From the following values of x and $\sin x$ find the value of $\frac{d}{dx} \sin x$ for $x = 20^\circ$ and verify that it is equal to $\cos 20^\circ$.

NOTE.— δx must be measured in radians, $1' = 0.0002909$ radian.

x .	$\sin x$.
$19^\circ 59'$	0.3417468
$20^\circ 0'$	0.3420201
$20^\circ 1'$	0.3422935

24. From the following values of x and $\cos x$ verify that $\frac{d}{dx} \cos x = -\sin x$ for the case $x = 30^\circ$.

x .	$\cos x$.
$29^\circ 59'$	0.8661708
$30^\circ 0'$	0.8660254
$30^\circ 1'$	0.8658799

25. Verify that $\frac{d}{dx} \cos x = -\sin x$ for the case $x = 74^\circ$.

x .	$\cos x$.
$73^\circ 59'$	0.2759170
$74^\circ 0'$	0.2756374
$74^\circ 1'$	0.2753577

26. Draw the portions of the curves

$$y = \sin x, \text{ and } y = \sin 3x$$

between $x = 0.1745$ radian = 10° and $x = 0.3491$ radian = 20° , plotting the values of x in radians. Measure the slope of both curves when $x = 0.2618$, radian = 15° , and compare the measured values of the slope with the values $\cos x$ and $3 \cos 3x$ given by differentiation.

27. Give the proof, as in § 108, that

$$\frac{d}{dx} a \sin (bx + c) = ab \cos (bx + c)$$

28. Find the first eight differential coefficients of $\sin x$ and $\cos x$.

Find the value of—

29. $\frac{d^2}{dt^2} a \sin (qt + g)$.

30. $\frac{d^2}{dx^2} 3 \sin (2x + 4)$.

31. $\frac{d^2}{dx^2} \{1.2 \sin (2.6x - 4.1)\}$.

32. If $s = 4 \sin 2t + 8 \cos 2t$, prove that s satisfies the equation $\frac{d^2s}{dt^2} + 4s = 0$.

33. If $y = A \sin (4x + B)$, find the value of $\frac{d^2y}{dx^2} + 16y$.

34. If $y = A \sin (nt + g)$, find the value of $\frac{d^2y}{dt^2} + n^2y$.

35. $y = a \sin pt + b \cos pt$. Find the value of $\frac{dy}{dt}$. Express $\frac{dy}{dt}$ in the form $A \sin (pt + g)$. (See § 37.)

36. If a piece of mechanism moves with a simple harmonic motion, its distance s from a fixed point on its path at time t is given by the equation

$$s = a \sin (2\pi nt + g),$$

where a , g and n are constants. Find expressions for the velocity and acceleration at any time. Show that the acceleration is proportional to s .

37. In the last example, take $g = 0$, $a = 0.458$ ft., $n = \frac{135}{60}$, and plot curves to show (a) the distance s , (b) the velocity, (c) the acceleration at any time from $t = 0$ to $t = 0.44$ seconds.

38. A mass M moves in a straight line with a simple harmonic motion given by the equation $s = a \sin gt$, where s is the distance of its centre of gravity from the mid point of its path at time t . If v is its velocity find expressions for its kinetic energy $\frac{1}{2} Mv^2$, and its momentum Mv at any time t . The force on the body at any time is measured by the mass multiplied by the acceleration. Find an expression for the force at any time, and show that it is equal to the rate of increase of the momentum with respect to the time.

39. A closed plane circuit of wire enclosing an area A square centimetres is rotating with angular velocity q radians per second in a magnetic field of intensity H . If t is measured from the instant when the plane of the circuit is parallel to the field, the magnetic induction through the circuit is $I = AH \sin qt$.

The electromotive force V in the wire, expressed in volts, is the rate of increase of the magnetic induction per second multiplied by 10^{-8} . Find an expression for the electromotive force at any time. In the case when $A = 550$ sq. cms., $q = \frac{1100 \times 2\pi}{60}$, $H = 7500$, plot a curve to show the electromotive force at any time from $t = 0$ to $t = 0.0545$ secs.

40. The equation $\frac{d^2u}{dx^2} = m^2u$ occurs in the theory of the whirling of shafts. m is a constant. Show that this equation is satisfied by putting

$$u = Ae^{mx} + Be^{-mx} + C \cos mx + D \sin mx.$$

41. The equation

$$\frac{d^2u}{dx^2} + \frac{Pu}{EI} + \frac{WL}{8EI} \cos \frac{\pi x}{L} = 0$$

occurs in finding the shape of a strut which carries a thrust at the end, and also a lateral load. Show that it is satisfied by putting

$$u = \frac{\frac{1}{8}WL \cos \frac{\pi x}{L}}{EI \frac{\pi^2}{L^2} - P}$$

All the letters except u and x represent constants.

42. If $s = a \sin t + b \sin 2t + c \sin 3t$, find the value of $\frac{ds}{dt}$ and $\frac{d^2s}{dt^2}$.

43. If $x = r \sin qt + \frac{r^2}{4l} \cos 2qt - \frac{r^2}{4l}$, where x is the displacement at time t of the piston of a steam-engine from the middle of its stroke, r = length of crank, l = length of connecting rod, find expressions for the velocity and acceleration.

What are the values of the acceleration when $t = 0, \frac{\pi}{2q}$ and $\frac{\pi}{q}$?

44. A point moves along a straight line so that its distance s from a fixed point on the line is given by $s = a \sin (2\pi ft + g) + b \sin (3\pi ft + h)$; $a, b, f, g,$ and h are constants. Write down expressions for the velocity and acceleration at any time. Plot a curve to show the value of s for any value of t when $a = 1.5, b = 0.6, g = 0.733, h = 0.951, f = \frac{11}{6}$.

113. Differentiation of log x .

If y is a function of x , and δy and δx are simultaneous increments of y and x , then

$$\frac{\delta y}{\delta x} = \frac{1}{\frac{\delta x}{\delta y}}$$

This remains true as δy and δx are made smaller and smaller, and $\frac{\delta y}{\delta x}$ approaches the limiting value $\frac{dy}{dx}$.

$$\therefore \frac{dy}{dx} = \frac{1}{\frac{dx}{dy}}$$

Let $y = \log_e x$

Then $x = e^y$

and $\frac{dx}{dy} = e^y = x$

$$\therefore \frac{dy}{dx} = \frac{1}{\frac{dx}{dy}} = \frac{1}{x}$$

It follows in the same way that

$$\frac{d}{dx} \{A \log_e (Bx + C)\} = \frac{AB}{Bx + C}$$

where A, B, and C are constants.

Since $\log_{10} x = 0.4343 \log_e x$, we have as a special case

$$\frac{d}{dx}(\log_{10} x) = \frac{0.4343}{x}$$

We may verify this result numerically as follows :—

From the tables we have

x.	log _e x = y.	δy.	δx.	$\frac{\delta y}{\delta x}$.	$\frac{dy}{dx}$ (mean).
5.40	1.6863989	0.0018502	0.01	0.18502	0.18484
5.41	1.6882491	0.0018467	0.01	0.18467	
5.42	1.6900958				

We have by differentiation

$$\frac{d}{dx}(\log_e x) = \frac{1}{x} = \frac{1}{5.41} = 0.18484, \text{ for } x = 5.41$$

which agrees to 5 significant figures.

EXAMPLES.—LXI.

Find the value of the following :—

- | | | |
|---------------------------------------|---------------------------------------|--|
| 1. $\frac{d}{dx}(\log_e 5x)$. | 2. $\frac{d}{dx}\{\log_e(4x+3)\}$. | 3. $\frac{d}{dx}\{\log_e 4x+3\}$. |
| 4. $\frac{d}{dx}\{6 \log_e(1-2x)\}$. | 5. $\frac{d}{dt}\{3 \log_e(5t+4)\}$. | 6. $\frac{d}{ds}\{6 \log_{10}(7s+3)\}$. |
| 7. $\frac{d}{du}(\log_{10} 5u)$. | 8. $\frac{d^2}{dx^2}(\log_e x)$. | 9. $\frac{d^2}{dx^2}(\log_e x)$. |
| 10. $\frac{d^2}{dx^2}(\log_e 3x)$. | 11. $\frac{d^2}{dx^2}(\log_e 3x+2)$. | |

12. Verify the result of differentiating $\log_e x$ from the following values :—

x.	log _e x.
8.60	2.1517622
8.61	2.1529243
8.62	2.1540851
8.63	2.1552445

Plot two curves showing the values of (a) $\log_e x$, (b) $\frac{1}{x}$, for the above values of x, and verify that the ordinate of b at any point measures the slope of a.

13. Find the value of $\frac{d}{dx} \log_{10} x$, when $x = 4.1735$, from the following values, and compare with the result obtained by differentiating :—

x .	$\log_{10} x$.
4'1734	0'6204900
4'1735	0'6205004
4'1736	0'6205108

14. Plot the curves (a) $y = \log_e x$, (b) $y = \log_{10} x$, between $x = 2$ and $x = 2.5$. Verify by measurement at three places on each curve that the slope of (b) is 0'4343 of the slope of (a) for the same value of x .

15. Find the value of $\frac{d}{dx} \{ \log_e(x+2) \}$, when $x = 6.23$, from the following values, and compare with the result of differentiating:—

x .	$y = \log_e(x+2)$.
6'20	2'1041341
6'22	2'1065720
6'24	2'1089998
6'26	2'1114243

16. If $\phi_x = \log_e \frac{t}{273.7} + \frac{797}{t} - 0.695$, find an expression for $\frac{d\phi_x}{dt}$.

17. If $\phi = 0.737 \log_e \frac{t}{273.7} + 2.875 \cdot 10^{-4}(t^2 - 1096t) + 0.648$, find $\frac{d\phi}{dt}$.

EXAMPLES.—LXII

Miscellaneous Examples in Differentiation.

Find the value of the following:—

- $\frac{d}{dx} \{ x^3 - e^{\frac{1}{2}x} + \sin x \}$.
- $\frac{d}{dx} \left\{ x^{11} + \frac{1}{e^{3x}} - \cos 2x \right\}$.
- $\frac{d}{dx} \left\{ x^{-17} + \frac{1}{\sqrt{e^x}} + \sin(3x+2) \right\}$.
- $\frac{d}{dx} \{ e^{-2.35x} + \sqrt{x^2} + \cos(2x-1) \}$.
- $\frac{d}{dx} \{ e^{-1.2x} + \sqrt{x^{1.3}} - 5 \sin(3x+4) + 6 \cos(2x-1) \}$.
- $\frac{d}{dt} \left\{ e^{-2.3t} + \frac{1}{\sqrt{t}} - \frac{1}{t^2} - 4 \cos(1-3t) \right\}$.
- $\frac{d}{dx} \left\{ 2x^{1.3} - \frac{1}{x^{2.1}} + 3e^{2x} - \frac{2}{e^{3x}} + \sin(2x+1) \right\}$.
- $\frac{d}{du} \left\{ 4.3u^{2.7} - \frac{1.3}{u^{0.5}} + 2.3e^{1.1u} - 5.73 \right\}$.
- $\frac{d}{du} \{ 3.1u^{6.9} - 2.1 \sin(1-3u) - 5 \cos(2-4.3u) + 1.9e^{5.3} - 6\sqrt{u} \}$.
- $\frac{d}{dt} \{ t^2 - t + \frac{1}{t} - t^{1.3} - t^{-2.0} + 1 \}$.
- $\frac{d}{du} \{ u^6 - 3e^{2u} - \frac{4}{e^{3u}} + 6e^{-u} - \sqrt{e^u} + 3e^{2u} - e^2 \}$.
- $\frac{d}{dt} \{ e^{2t} - 3 \sin(2t+1) + 4 \cos(3t-2) + \sin(1-4t) - 2 \cos(1-t) + 3 \cos(0.7854) \}$.

CHAPTER XII

DIFFERENTIATION OF A PRODUCT, QUOTIENT, AND FUNCTION OF A FUNCTION

114. Differentiation of a Product.

Let $y = uv$, where u and v are functions of x which can be differentiated.
Let x increase to $x + \delta x$, so that, in consequence,

$$\begin{array}{lcl} u & \text{becomes} & u + \delta u \\ v & \text{,,} & v + \delta v \\ y & \text{,,} & y + \delta y \end{array}$$

$$\begin{aligned} \text{Then } y + \delta y &= (u + \delta u)(v + \delta v) \\ &= uv + u\delta v + v\delta u + \delta u \cdot \delta v \\ \text{and since } y &= uv \end{aligned}$$

subtracting, we get,

$$\begin{aligned} \delta y &= u\delta v + v\delta u + \delta u\delta v \\ \therefore \frac{\delta y}{\delta x} &= u \frac{\delta v}{\delta x} + v \frac{\delta u}{\delta x} + \delta u \frac{\delta v}{\delta x} \end{aligned}$$

In the limit, when δx diminishes indefinitely, $\frac{\delta y}{\delta x}$, $\frac{\delta u}{\delta x}$, $\frac{\delta v}{\delta x}$ become $\frac{dy}{dx}$, $\frac{du}{dx}$, $\frac{dv}{dx}$ respectively, and the term $\delta u \frac{\delta v}{\delta x}$ becomes $0 \times \frac{dv}{dx} = 0$.

$$\therefore \frac{dy}{dx} = u \frac{dv}{dx} + v \frac{du}{dx}$$

EXAMPLES—(1.)—Let $y = x^2 e^{2x}$.

$$\begin{aligned} \text{Take } u &= x^2, v = e^{2x}; \\ \text{then } \frac{dy}{dx} &= u \frac{dv}{dx} + v \frac{du}{dx} = x^2 \cdot \frac{d}{dx}(e^{2x}) + e^{2x} \frac{d}{dx}(x^2) \\ &= 5x^2 e^{2x} + 3x^2 e^{2x} = (5x + 3)x^2 e^{2x} \end{aligned}$$

(2.)—Let $y = x^4 \sin(2x + 1)$.

$$\begin{aligned} \text{Take } u &= x^4, v = \sin(2x + 1) \\ \frac{dy}{dx} &= u \frac{dv}{dx} + v \frac{du}{dx} \\ &= x^4 \frac{d}{dx} \{\sin(2x + 1)\} + \{\sin(2x + 1)\} \times \frac{d}{dx}(x^4) \\ &= 2x^4 \cos(2x + 1) + 4x^3 \sin(2x + 1) \end{aligned}$$

(3.) Let $y = 2e^{2x} \sin(3x + 1)$.

Let $u = 2e^{2x}$; $v = \sin(3x + 1)$.

$$\begin{aligned} \frac{dy}{dx} &= 2e^{2x} \frac{d}{dx} \{\sin(3x + 1)\} + \{\sin(3x + 1)\} \times \frac{d}{dx} (2e^{2x}) \\ &= 6e^{2x} \cos(3x + 1) + 4e^{2x} \sin(3x + 1) \end{aligned}$$

(4.) Let $y = \frac{\log_e(x-3)}{\sqrt{x}}$.

Take $u = \log_e(x-3)$; $v = \frac{1}{\sqrt{x}} = x^{-\frac{1}{2}}$.

$$\begin{aligned} \frac{dy}{dx} &= \log_e(x-3) \frac{d}{dx} \cdot x^{-\frac{1}{2}} + x^{-\frac{1}{2}} \frac{d}{dx} \log_e(x-3) \\ &= -\frac{1}{2x^{\frac{3}{2}}} \log_e(x-3) + \frac{1}{\sqrt{x}(x-3)} \end{aligned}$$

(5.) To prove the rule for differentiating x^n by means of the rule for differentiating a product for the case when n is a positive whole number.

It follows from the definition of a differential coefficient that $\frac{dx}{dx} = 1$.

Then $\frac{d(x^2)}{dx} = \frac{d(x \times x)}{dx} = x \frac{dx}{dx} + x \frac{dx}{dx} = 2x$.

$$\frac{dx^3}{dx} = \frac{d(x \times x^2)}{dx} = x^2 \frac{dx}{dx} + x \frac{dx^2}{dx} = x^2 + 2x \cdot x = 3x^2.$$

$$\frac{dx^4}{dx} = \frac{d(x \times x^3)}{dx} = x^3 \frac{dx}{dx} + x \frac{dx^3}{dx} = x^3 + 3x^2 = 4x^3.$$

In the same way, it evidently follows that as we proceed to higher powers of x the effect of each addition of one to the power of x is to add $\frac{dx}{dx} = 1$ to the numerical coefficient, and to raise the power of the differential coefficient by unity, and therefore if n is a positive whole number $\frac{d(x^n)}{dx} = nx^{n-1}$.

EXAMPLES.—LXIII.

Find the value of—

- | | | |
|--|---------------------------------------|--|
| 1. $\frac{d}{dx} e^{-2x} \cos x$. | 2. $\frac{d}{dx} e^{-3x} \sin(x-1)$. | 3. $\frac{d}{dx} e^{-5x} \sin(3-2x)$. |
| 4. $\frac{d}{dx} (\sin 2x) \log_e(x+1)$. | | 5. $\frac{d}{dx} \sin 3x \cos 5x$. |
| 6. $\frac{d}{dx} 7 \sin 4x \cos 6x$. | | 7. $\frac{d}{dx} 10 \sin 3x \sin 7x$. |
| 8. $\frac{d}{dx} 15 \cos 6x \cos 5x$. | | 8. $\frac{d}{dx} \sin(2x+1) \cos(3x+2)$. |
| 10. $\frac{d}{dx} \cos(3x+1) \cos(4x-5)$. | | 11. $\frac{d}{dx} \sin(2x+1) \sin(2x+3)$. |
| 12. $\frac{d}{dx} \sin(ax+b) \sin(ax+d)$. | | 13. $\frac{d}{dx} \cos(ax+b) \cos(bx+c)$. |
| 14. $\frac{d}{dx} \sin(ax+b) \cos(cx+d)$. | | 15. $\frac{d}{dx} x^3 \sin x$. |
| 16. $\frac{d}{dx} x^{131} \sin(2x+1)$. | 17. $\frac{d}{dx} x^2 e^{2x}$. | 18. $\frac{d}{dx} x^n e^{bx}$. |

19. If $y = Ae^{-2x} \sin(x + B)$, find the value of $\frac{d^2y}{dx^2} + 4\frac{dy}{dx} + 5y$.

20. If $y = (A + Bx)e^{-2x}$, find the value of $\frac{d^2y}{dx^2} + 4\frac{dy}{dx} + 4y$.

21. If $y = Ae^{-x} \sin(\sqrt{2}x + B)$, find the value of $\frac{d^2y}{dx^2} + 2\frac{dy}{dx} + 3y$.

22. If $v = Ae^{-\frac{ht}{2L}} \sin\left(\sqrt{\frac{1}{KL} - \frac{R^2}{4L^2}} \cdot t + B\right)$, where all the letters except v and t represent constants, show that

$$L\frac{d^2v}{dt^2} + R\frac{dv}{dt} + \frac{v}{K} = 0.$$

115. Differentiation of a Quotient.

Let $y = \frac{u}{v}$ where u and v are functions of x which can be differentiated.

Then, if $\delta x, \delta u, \delta v, \delta y$ are simultaneous increments of $x, u, v,$ and $y,$

$$y + \delta y = \frac{u + \delta u}{v + \delta v}$$

$$y = \frac{u}{v}$$

Subtracting

$$\delta y = \frac{u + \delta u}{v + \delta v} - \frac{u}{v} = \frac{uv + v\delta u - uv - u\delta v}{(v + \delta v)v}$$

Dividing by δx we get

$$\frac{\delta y}{\delta x} = \frac{v \frac{\delta u}{\delta x} - u \frac{\delta v}{\delta x}}{(v + \delta v)v}$$

In the limit, when δx diminishes indefinitely, $\frac{\delta y}{\delta x}, \frac{\delta u}{\delta x}, \frac{\delta v}{\delta x}$ become $\frac{dy}{dx}, \frac{du}{dx}, \frac{dv}{dx}$

respectively, and we get $\frac{dy}{dx} = \frac{v \frac{du}{dx} - u \frac{dv}{dx}}{v^2}$

EXAMPLE (1).—To differentiate $\tan x$.

$$\text{Let } y = \tan x = \frac{\sin x}{\cos x} = \frac{u}{v}$$

where $u = \sin x$ and $v = \cos x$.

$$\begin{aligned} \text{Then } \frac{dy}{dx} &= \frac{v \frac{du}{dx} - u \frac{dv}{dx}}{v^2} \\ &= \frac{\cos x \cdot \cos x - \sin x (-\sin x)}{\cos^2 x} = \frac{\cos^2 x + \sin^2 x}{\cos^2 x} \\ &= \sec^2 x \end{aligned}$$

This is an important result, and should be remembered.

EXAMPLE (2).—Let $y = \frac{e^x}{\sin x} = \frac{u}{v}$, where $u = e^x$, $v = \sin x$.

$$\begin{aligned} \text{Then } \frac{dy}{dx} &= \frac{v \frac{du}{dx} - u \frac{dv}{dx}}{v^2} = \frac{\sin x \cdot e^x - e^x \cos x}{\sin^2 x} \\ &= e^x \frac{\sin x - \cos x}{\sin^2 x}. \end{aligned}$$

EXAMPLE (3).—To verify the rule for differentiating a quotient for the case $y = \frac{x^6}{x^2} = \frac{u}{v}$ where $u = x^3$, $v = x^2$.

$$\text{Then } \frac{dy}{dx} = \frac{v \frac{du}{dx} - u \frac{dv}{dx}}{v^2} = \frac{x^2 \cdot 6x^3 - x^6 \cdot 2x}{x^4} = 4x^3.$$

But we may also take $y = x^3$, and $\therefore \frac{dy}{dx} = 4x^3$ by the previous method for differentiating x^n .

EXAMPLES.—LXIV.

Find the value of the following:—

- | | | |
|--|--|---|
| 1. $\frac{d}{dx} \frac{\cos 3x}{x^2}$. | 2. $\frac{d}{dx} \frac{\sin(1-3x)}{x}$. | 3. $\frac{d}{dx} \left(\frac{e^{-3x}}{\sqrt{x}} \right)$. |
| 4. $\frac{d}{dx} (x^{15})$. | 5. $\frac{d}{dx} \left(\frac{\sin x}{\log_e x} \right)$. | 6. $\frac{d}{dx} \left(\frac{\cos x}{e^x} \right)$. |
| 7. $\frac{d}{dx} (\sec x)$. | 8. $\frac{d}{dx} (\operatorname{cosec} x)$. | 9. $\frac{d}{dx} (\cot x)$. |
| 10. $\frac{d}{dx} \left(\frac{1}{\log_e x} \right)$. | | |

11. If $\sinh x = \frac{e^x - e^{-x}}{2}$, $\cosh x = \frac{e^x + e^{-x}}{2}$, and $\tanh x = \frac{\sinh x}{\cosh x}$. Find the value of $\frac{d}{dx} (\tanh x)$.

12. Show that $\frac{d}{dx} (x \log_e x - x) = \log_e x$. This result is important.

13. Prove the rule for differentiating x^n for the case where n is a negative whole number by using the rule for differentiating a quotient.

- | | | |
|---|--|--|
| 14. $\frac{d}{dx} \cdot \frac{2 \sin(2x-3)}{5e^{3x}}$. | 15. $\frac{d}{dx} \cdot \frac{\sin(3x-1)}{\cos(2x+3)}$. | 16. $\frac{d}{dx} \cdot \frac{e^{-2x}}{\cos(2x+3)}$. |
| 17. $\frac{d}{dx} \cdot \frac{2e^{3x}}{\log_e(x-1)}$. | 18. $\frac{d}{dx} \cdot \frac{x-3}{(x+5)^2}$. | 19. $\frac{d}{dx} \cdot \frac{\sin 2x}{\log_e(x-3)}$. |
| 20. $\frac{d}{dx} \cdot \frac{3e^{2x}}{\cos(2x-1)}$. | 21. $\frac{d}{dx} \cdot \frac{\log_e(x-4)}{\cos(31x+7)}$. | |

116. Function of a Function.—We may require to differentiate such a function as $\sin(x^4)$ where we already know how to differentiate the functions $\sin u$ and x^4 separately.

Let $y = F(u)$ where u is a function, $f(x)$, of x and F and f are functions, which we can differentiate.

Let x increase by the increment δx , and at the same time let u increase by δu and y by δy .

Then $\frac{\delta y}{\delta x} = \frac{\delta y}{\delta u} \times \frac{\delta u}{\delta x}$ by algebra, since $\frac{\delta y}{\delta u}$ and $\frac{\delta u}{\delta x}$ are algebraical fractions.

Now let δx and consequently δu and δy be indefinitely diminished.

Then, in the limit, $\frac{\delta y}{\delta x}, \frac{\delta y}{\delta u}, \frac{\delta u}{\delta x}$ become $\frac{dy}{dx}, \frac{dy}{du},$ and $\frac{du}{dx}$ respectively.

$$\therefore \frac{dy}{dx} = \frac{dy}{du} \times \frac{du}{dx}$$

Note that, since $\frac{dy}{du}$ and $\frac{du}{dx}$ are no longer fractions, this does *not* follow at once by cancelling du .

EXAMPLE (1).—Let $y = \sin(x^4)$.

This is a sine of a fourth power and both of these are functions which we can already differentiate.

Let $u = x^4$; then $y = \sin u$

$$\frac{dy}{dx} = \frac{dy}{du} \times \frac{du}{dx} = \frac{d(\sin u)}{du} \times \frac{d(x^4)}{dx} = (\cos u) \times 4x^3 = 4x^3 \cos x^4.$$

EXAMPLE (2).— $y = \log_e(\sin x)$.

Let $\sin x = u$; then $y = \log_e u$

$$\frac{dy}{dx} = \frac{dy}{du} \times \frac{du}{dx} = \frac{d(\log_e u)}{du} \times \frac{d(\sin x)}{dx} = \frac{1}{u} \times \cos x = \frac{\cos x}{\sin x} = \cot x.$$

EXAMPLE (3).—Let $y = (1 - x)^n$.

Let $u = 1 - x$; then $y = u^n$

$$\text{and } \frac{dy}{dx} = \frac{dy}{du} \times \frac{du}{dx} = \frac{d(u^n)}{du} \times \frac{d(1 - x)}{dx} = 6u^5 \times (-1) = -6(1 - x)^6$$

Similarly $\frac{d}{dx}(ax + b)^n = an(ax + b)^{n-1}$ where a and b are any constants.

EXAMPLE (4).— $y = \log_e \frac{x-3}{\sqrt{2x+1}}$.

We must here combine the various methods of this chapter.

Let $\frac{x-3}{\sqrt{2x+1}} = w$; then $y = \log w$

$$\text{and } \frac{dy}{dx} = \frac{dy}{dw} \times \frac{dw}{dx} = \frac{1}{w} \times \frac{dw}{dx}$$

To find $\frac{dw}{dx}$, let $w = \frac{u}{v}$ where $u = x - 3$, $v = \sqrt{2x + 1}$.

$$\text{Then } \frac{dw}{dx} = \frac{v \frac{du}{dx} - u \frac{dv}{dx}}{v^2}$$

$$= \frac{\sqrt{2x+1} - (x-3) \frac{d}{dx} \sqrt{2x+1}}{2x+1}$$

$$= \frac{\sqrt{2x+1} - \frac{x-3}{\sqrt{2x+1}}}{2x+1} \quad (\text{see example 3})$$

$$= \frac{x+4}{(2x+1)^{\frac{3}{2}}}$$

∴ substituting and simplifying

$$\frac{dy}{dx} = \frac{x+4}{(x-3)(2x+1)}$$

EXAMPLE (5).—To find an expression for the slope of the tangent to a circle at any point.

Take the centre of the circle as origin of rectangular co-ordinates. Let the radius = a , and let x and y be the co-ordinates of any point P on the circle.

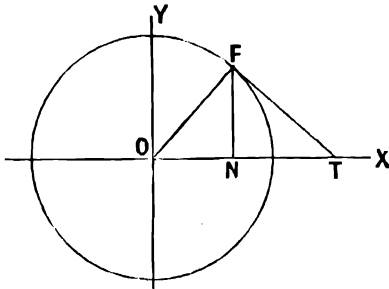

FIG. 88.

$$\text{Then } x^2 + y^2 = a^2; \quad y = \sqrt{a^2 - x^2}.$$

We require to find $\frac{dy}{dx}$.

Let $u = a^2 - x^2$; then $y = \sqrt{u}$, and the slope of the tangent to the circle at P is

$$\begin{aligned} \frac{dy}{dx} &= \frac{dy}{du} \times \frac{du}{dx} = \frac{d\sqrt{u}}{du} \times \frac{d(a^2 - x^2)}{dx} \\ &= \frac{1}{2\sqrt{u}} \times (-2x) = \frac{-x}{\sqrt{a^2 - x^2}} = -\frac{x}{y} \end{aligned}$$

Note that in the figure, $\frac{x}{y} = \tan NPO$, and slope of $PT = -\tan NTP$.

Thus the above result proves that $NPO = NTP$, and therefore $NPT = NOP$, and OPT is a right angle, or the tangent to a circle is perpendicular to the radius at the point of contact.

EXAMPLE (6).— OP is a crank of length a , revolving with constant angular velocity ω , in a counter-clockwise direction. PQ is a connecting-rod of length l . Q moves backwards and forwards in the straight line OQ . OR is perpendicular to OQ , PN to OR , and PM to OQ .

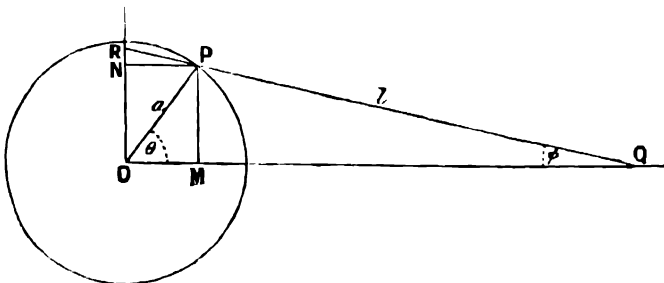

FIG. 89.

Prove that PR represents on some scale the angular velocity of the connecting-rod PQ .

Let $\angle POQ = \theta$, $\angle PQO = \phi$.

Then $PM = a \sin \theta = l \sin \phi$.

Differentiate both sides of this equation with respect to t .

$$\frac{d}{dt}(a \sin \theta) = a \frac{d}{d\theta}(\sin \theta) \times \frac{d\theta}{dt} = a \cos \theta \frac{d\theta}{dt}$$

$$\frac{d}{dt}(l \sin \phi) = l \cos \phi \frac{d\phi}{dt}$$

Now $\frac{d\phi}{dt}$ is the angular velocity of the connecting-rod PQ, and $\frac{d\theta}{dt}$ is the angular velocity of the crank OP, and is constant and equal to ω .

$$\therefore \omega a \cos \theta = l \cos \phi \frac{d\phi}{dt}$$

$$\frac{d\phi}{dt} = \omega \frac{a \cos \theta}{l \cos \phi}$$

$$\text{Now PR} = \frac{\text{PN}}{\cos \text{NPR}} = \frac{\text{OM}}{\cos \phi} = a \frac{\cos \theta}{\cos \phi}$$

$$\therefore \frac{d\phi}{dt} = \frac{\omega}{l} \cdot \text{PR}$$

i.e. PR is proportional to the angular velocity of the connecting-rod PQ.

EXAMPLES.—LXV.

Find the value of—

- | | | |
|--|--|---|
| 1. $\frac{d}{dx}(2-x)^4.$ | 2. $\frac{d}{dx} \cdot \frac{1}{1-x}.$ | 3. $\frac{d}{dx} \cdot \frac{1}{2+3x}.$ |
| 4. $\frac{d}{dx} \cdot \frac{1}{2-3x}.$ | 5. $\frac{d}{dx} \sqrt{4-3x}.$ | 6. $\frac{d}{dx} \sqrt{2x+1}.$ |
| 7. $\frac{d}{dx} \cdot \frac{1}{\sqrt{5-2x}}.$ | 8. $\frac{d}{dx} \sqrt{2x^2+4x-1}.$ | 9. $\frac{d}{dx} \sqrt{a^2+x^2}.$ |
| 10. $\frac{d}{dx} \sqrt{x^2-3x+5}.$ | 11. $\frac{d}{dx} \sqrt{ax^2+bx+c}.$ | 12. $\frac{d}{dx} \log_e(2x+1).$ |
| 13. $\frac{d}{dx} \cdot \log_e(3-4x).$ | 14. $\frac{d}{dx} \cdot \log_e(1-x).$ | 15. $\frac{d}{dx} \log_e(x^2-2x+5)$ |
| 16. $\frac{d}{dx} \cdot \log_e(2x^2-3x+4).$ | 17. $\frac{d}{dx} \log_e(ax^2+bx+c).$ | |

18. We have $\log_e(x^2+x-12) = \log_e(x-3) + \log_e(x+4)$. Differentiate both sides of this equation separately, and verify that the result is the same in both cases.

Differentiate with respect to x —

- | | | | |
|--|--------------------------------|--|----------------------------|
| 19. $\text{Sin}^3 x.$ | 20. $\text{Sin } x^3.$ | 21. $\text{Log}_e(x^3).$ | 22. $(\log_e x)^3.$ |
| 23. $e^{(x^3)}.$ | 24. $(e^x)^3.$ | 25. $\text{Sin}^3 x.$ | 26. $\text{Log}_e \cos x.$ |
| 27. $e^{\ln 2x}.$ | 28. $\text{Cos}(e^x).$ | 29. $\text{Log}_e(e^x).$ | 30. $\text{Cos}^3(2x-1).$ |
| 31. $\text{Log}_e \sin(3x+2).$ | 32. $\text{Log} \tan x.$ | 33. $\text{Sin}^2 x \cos^3 x.$ | |
| 34. $\frac{1}{\cos^3 x}.$ | 35. $\text{Sin}^m x \cos^n x.$ | 36. Show that $\frac{d}{dx} e^{ax+b} = ae^{ax+b}.$ | |
| 37. Show that $\frac{d}{d(x+a)} \cdot x^n = nx^{n-1}.$ (Put $x+a = z$, and $x = z-a$.) | | | |
| 38. Find $\frac{d}{dx} \log_e ax$, where a is any constant. | | | |

Find the value of—

39. $\frac{d}{dx} \log_e (x + \sqrt{x^2 + a^2})$.

40. $\frac{d}{dx} \cdot \frac{1}{2a} \log_e \frac{x-a}{x+a}$.

41. $\frac{d}{dx} \log_e \frac{2x+3}{x+2}$.

42. $\frac{d}{dx} \log_e \frac{x-4}{\sqrt{2x-3}}$.

43. Prove that **OR** in Fig. 89 represents on some scale the linear velocity of the point **Q**.

CHAPTER XIII

CALCULATION OF SMALL CORRECTIONS

117. LET **A** and **B** be two neighbouring points on a curve representing y as a function of x . Let (x_1, y_1) be the co-ordinates of **A**, and $(x_1 + \delta x, y_1 + \delta y)$ the co-ordinates of **B**.

Then, if **AN** and **NB** are parallel to the axes of x and y , **AN** = δx , **NB** = δy .

Then $\frac{\delta y}{\delta x}$ is the slope of the chord **AB**.

It appears evident from the figure, and can also be proved analytically, that **AB** is parallel to the tangent to the curve at some point **C** between **A** and **B**.

Now $\frac{dy}{dx}$ measures the slope of the tangent to the curve.

$\therefore \frac{\delta y}{\delta x}$ = slope of chord **AB** = value of $\frac{dy}{dx}$, corresponding to some point **C** between **A** and **B**.

$\therefore \delta y = \frac{dy}{dx} \delta x$ where the value of $\frac{dy}{dx}$ is taken for some value of x between x_1 and $x_1 + \delta x$.

If δx is sufficiently small, we may take the value of $\frac{dy}{dx}$ at **A** instead of at **C** in the above equation, with an error which is, in general, small compared with δx .

Thus, if a small variation δx occurs in the value of x , the corresponding variation in y is $\frac{dy}{dx} \delta x$.

EXAMPLE (1).—The radius of a circle is found by measurement to be 3.26 inches, and the area is calculated from this value.

If there may be an error of 2 per cent. in the observed value of the radius, what is the possible error in the calculated value of the area?

Let x = the radius, y the area;

$$\text{then } y = \pi x^2$$

But if there is an error δx in the observed value of x , it has just been shown that the consequent error in y is $\delta y = \frac{dy}{dx} \delta x = 2\pi x \delta x$.

$$\therefore \text{if } \delta x = (2 \text{ per cent. of } x) = \frac{x}{50}$$

$$\delta y = 2\pi x \delta x = \frac{\pi x^2}{25}$$

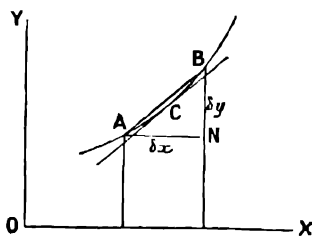

FIG. 90.

And the percentage error in y is $\frac{100 \cdot \delta y}{y} = \frac{\pi x^2 \cdot 100}{25 \cdot \pi x^2} = 4$ per cent.

EXAMPLE (2).—An electrical resistance y is measured by balancing it against a known resistance ω by means of a slide wire bridge. $l - x$ and x are the resistances of the proportional arms of the bridge corresponding to y and ω respectively.

It is required to find the error in the value obtained for y , due to a known small error a in the value of x .

It is known that

$$\begin{aligned}\frac{y}{\omega} &= \frac{l-x}{x} = \frac{l}{x} - 1 \\ y &= \frac{l\omega}{x} - \omega \\ \therefore \delta y &= \frac{dy}{dx} \delta x = -\frac{l\omega}{x^2} \delta x\end{aligned}$$

We have $\delta x = a$

$$\therefore \text{percentage error in } y = 100 \frac{\delta y}{y} = -\frac{l}{x(l-x)} \times 100 \cdot a$$

EXAMPLE (3).—The angle A of a triangle is found by measurement to be 63° , and the area is calculated by the formula $\frac{1}{2} bc \sin A$.

Find the percentage error in the calculated value of the area, due to an error of 1° in the observed value of A .

Let S = the area.

$$\text{Then } S = \frac{1}{2} bc \sin A$$

$$\delta S = \frac{dS}{dA} \delta A = \frac{1}{2} bc \cos A \cdot \delta A$$

$$\therefore \text{percentage error in } S = 100 \frac{\delta S}{S} = 100 \cot A \cdot \delta A$$

$$\text{Now } \delta A = 1^\circ = 0.0175 \text{ radian}$$

$$\therefore \text{percentage error in the area} = 100 \times \cot 63^\circ \times 0.0175 = 0.89 \text{ per cent.}$$

EXAMPLE (4).—An error equal to 1 in the fourth decimal place is made in obtaining the logarithm of a number as the result of a calculation with four-figure log tables. To find the consequent error in the number.

Let x be the logarithm obtained, and y its antilogarithm. Then we require to find the error in y due to an error of 0.0001 in x .

We have—

$$x = \log_{10} y$$

$$\delta x = \frac{dx}{dy} \cdot \delta y = \frac{0.4343}{y} \cdot \delta y$$

$$\therefore \delta y = \frac{y \delta x}{0.4343} = \frac{y}{4343} \text{ when } \delta x = 0.0001.$$

Thus the difference in a number corresponding to a difference of 1 in the fourth decimal place of its log is $\frac{1}{4343}$ of the number. This enables us to calculate the table of differences for antilogarithms.

EXAMPLES.—LXVI.

1. The radius of a sphere is found by measurement to be 5 ins. Find, by the methods of this chapter, the error caused in the calculated volume by an error of 1 per cent. in the measured value of the radius.

2. An error of 0.1° is made in measuring the value of an angle θ . What is the

consequent error in the value of the sine of the angle? Estimate the numerical value of this error (1) when θ is small, (2) when θ is nearly 89° .

3. The side a of a triangle is calculated from the formula $a^2 = b^2 + c^2 - 2bc \cos A$. Obtain expressions for the error in the value of a , consequent upon a known small error, (1) in the value of the angle A , (2) in the value of the side c .

4. The value of g , the acceleration due to gravity, is found to be 32.2 by calculation from the formula $T = 2\pi\sqrt{\frac{l}{g}}$, where T is the time of a complete oscillation of a pendulum of length l . What will be the calculated value of g if the value of T is measured 1 per cent. too large?

5. If V cubic feet is the volume of water displaced by a ship when drawing h feet of water, and if for a certain vessel $V = 1200h^{1.5}$, find an expression for the change produced in V , at any given draught h , by a change of 1 inch in h . Hence find an expression for the cross-sectional area A at the water-line for any value of h .

6. If x° is the reading of a tangent galvanometer when a current y passes through it, then $y = C \tan x$ where C is a constant. Find the percentage error in the estimated value of the current due to an error of 1° in the observed value of x , (1) when $x = 20^\circ$; (2) when $x = 45^\circ$; (3) when $x = 70^\circ$.

CHAPTER XIV

EXPANSION OF CERTAIN FUNCTIONS IN SERIES

118. IN Chapter VIII. it was seen that when the values of two variables y and x give points lying on a regular curve when plotted, and the equation to this curve does not seem to take any simple form, the law connecting y and x can be found in the form

$$y = a + bx + cx^2 + dx^3 + \dots$$

We found that the coefficients $a, b, c, d,$ etc., are in general smaller and smaller as the series is continued to higher powers of x ; and that we can usually obtain as close an approximation as we please to the actual law connecting y and x , by taking a sufficient number of terms.

When y is given as a function of x , it is often possible to find an equivalent series of the above form, by which the value of the function can be calculated.

119. Sin x and cos x .

EXAMPLE (1).—*To find a series for sin x in ascending powers of x .*
Assume that there is such a series,

$$\text{Let } \sin x = a + bx + cx^2 + dx^3 + \dots \quad (1)$$

Since this equation is assumed to be true for any value of x , we may substitute $x = 0$.

$$\text{We get } 0 = a + 0 + 0 + \dots$$

$\therefore a = 0$, the sum of all the remaining terms vanishing since we have assumed that the sum of the series is not infinite, however many terms are taken.

Differentiate both sides of the equation (1).

$$\cos x = b + 2cx + 3dx^2 + \dots \quad (2)$$

We here assume that an infinite series can be differentiated term by term, and that the result is the differential coefficient of the sum.

Putting $x = 0$ in equation (2), we get

$$\begin{aligned} 1 &= b + 0 + 0 \dots \\ \therefore b &= 1 \end{aligned}$$

Differentiating both sides of equation (2), we get

$$-\sin x = 2 \cdot c + 2 \cdot 3 \cdot d \cdot x + 3 \cdot 4 \cdot e \cdot x^2 + \dots$$

Putting $x = 0$, we get

$$0 = 2c \quad \therefore c = 0$$

Differentiating again, and putting $x = 0$, we get

$$d = -\frac{1}{1 \cdot 2 \cdot 3}$$

Similarly, we may find the values of the constants e, f, g, \dots to as many terms as we please by differentiating any number of times, and substituting $x = 0$ after differentiation.

We find that the coefficients of all the even powers of x vanish, and that the series is

$$\sin x = x - \frac{x^3}{1 \cdot 2 \cdot 3} + \frac{x^5}{1 \cdot 2 \cdot 3 \cdot 4 \cdot 5} - \frac{x^7}{1 \cdot 2 \cdot 3 \cdot 4 \cdot 5 \cdot 6 \cdot 7} + \dots$$

We may use this series to calculate the value of $\sin x$ when x is known.

It is, of course, assumed in the differentiation of the above series that x is measured in radians.

EXAMPLE (2).—Show in the same way that

$$\cos x = 1 - \frac{x^2}{1 \cdot 2} + \frac{x^4}{1 \cdot 2 \cdot 3 \cdot 4} - \frac{x^6}{1 \cdot 2 \cdot 3 \cdot 4 \cdot 5 \cdot 6} + \dots$$

EXAMPLE (3).—To calculate the value of $\sin 10^\circ$ correct to four decimal places.

We have $10^\circ = 0.1745$ radian

\therefore in the series

$$\sin x = x - \frac{x^3}{1 \cdot 2 \cdot 3} + \frac{x^5}{1 \cdot 2 \cdot 3 \cdot 4 \cdot 5} \dots$$

we must take $x = 0.1745$.

It is most convenient to arrange the work as follows, so that each term can be calculated from the preceding:—

	Positive terms.	Negative terms.
$x = 0.1745$	$= 0.1745$	
$x^2 = 0.03044$		
$\frac{x^3}{1 \cdot 2 \cdot 3} = \frac{x \times x^2}{6} = 0.1745 \times 0.005073$	$=$	0.000884
$\frac{x^5}{1 \cdot 2 \cdot 3 \cdot 4 \cdot 5} = \frac{x^3}{1 \cdot 2 \cdot 3} \times \frac{x^2}{20} = \frac{x^3}{1 \cdot 2 \cdot 3} \times 0.001522$	$=$	0.0000013
$\frac{x^7}{1 \cdot 2 \cdot 3 \cdot 4 \cdot 5 \cdot 6 \cdot 7} = \frac{x^5}{1 \cdot 2 \cdot 3 \cdot 4 \cdot 5} \times \frac{x^2}{42} = \frac{x^5}{1 \cdot 2 \cdot 3 \cdot 4 \cdot 5} \times 0.00072 =$		0.00000010
$\therefore \sin 10^\circ$	$= 0.1745$	$- 0.00088$
	$= 0.1736$	
	to four decimal places.	

We find from the tables that $\sin 10^\circ = 0.1736$. We see that the successive terms in the series for $\sin x$ get smaller and smaller. We have omitted all terms beyond $\frac{x^7}{1 \cdot 2 \cdot 3 \cdot 4 \cdot 5 \cdot 6 \cdot 7}$, assuming that their sum will not affect the fourth decimal place; this may be formally proved.

EXAMPLES.—LXVII.

1. Calculate the value of $\cos 10^\circ$, correct to four decimal places, and compare with the tables.
2. Calculate the value of $\sin 5^\circ$ correct to four decimal places, and compare with the tables.

3. Calculate the value of $\sin 20^\circ$ correct to four decimal places, and compare with the tables.

Note that as the angle becomes larger we require to take more terms of the series to obtain a value of the sine correct to any desired degree of accuracy, and that as x becomes smaller and smaller $\sin x$ becomes more and more nearly equal to x .

120. $\text{Log}_e(1+x)$.

EXAMPLE (1).—To find a series for $\log_e(1+x)$.

Assume $\log_e(1+x) = a + bx + cx^2 + dx^3 + ex^4 + \dots$

Putting $x = 0$ we have $a = \log_e(1) = 0$.

Differentiating with respect to x we have

$$\frac{1}{1+x} = b + 2cx + 3dx^2 + 4ex^3 \dots$$

Substituting $x = 0$ we have $b = 1$.

Differentiating again, we get

$$\frac{-1}{(1+x)^2} = 2c + 2 \cdot 3dx + 3 \cdot 4ex^2 + \dots$$

Substituting $x = 0$ we have $c = -\frac{1}{2}$.

Differentiating again,

$$\frac{-1 \cdot -2}{(1+x)^3} = 2 \cdot 3d + 2 \cdot 3 \cdot 4ex + \dots$$

Substituting $x = 0$, we have $d = \frac{1}{3}$.

Similarly, $e = -\frac{1}{4}$, and so on, and the series is

$$\log_e(1+x) = x - \frac{x^2}{2} + \frac{x^3}{3} - \frac{x^4}{4} + \frac{x^5}{5} - \dots$$

It can be shown that the assumptions involved in this proof are permissible when x is numerically less than 1.

EXAMPLE (2).—To calculate $\log_{10} 1.05$ correct to four decimal places.

We shall first find $\log_e(1.05)$ by putting $x = 0.05$ in the above series.

$$\log_e(1.05) = 0.05 - \frac{(0.05)^2}{2} + \frac{(0.05)^3}{3} - \dots$$

	Positive terms.	Negative terms.
$x =$	0.05	
$\frac{x^2}{2} =$	$\frac{0.0025}{2}$	= 0.00125
$\frac{x^3}{3} =$	$\frac{0.000125}{3}$	= 0.0000417
$\frac{x^4}{4} =$	$\frac{0.00000625}{4}$	= 0.00000156
$\log_e(1+x) =$	0.05004	- 0.0012516
	= 0.04879	
$\therefore \log_{10} 1.05 =$	0.04879 \times 0.4343	
	= 0.0212	

The value given in the tables is 0.0212 to four decimal places.

We do not here consider the question of how far the assumptions involved in the proofs of the series of this chapter are allowable. The student may

satisfy himself by numerical examples, like the above, that the results obtained are correct for the series which we treat of here.

At the present stage, he will not meet with any series where these assumptions cannot be allowed.

EXAMPLES.—I.XVIII.

1. Calculate $\log_{10} 1.01$, $\log_{10} 1.1$, $\log_{10} 1.2$, $\log_{10} 1.3$, correct to four places of decimals, and compare with the tables.

Note that more terms are required as x becomes larger.

2. If $x = \frac{1}{n}$ we have

$$\log(1 + x) = \log \frac{(n + 1)}{n} = \log(n + 1) - \log n$$

Thus if $\log n$ is known we can calculate $\log(n + 1)$ by using the series for $\log(1 + x)$. Calculate $\log_{10} 3$ having given that $\log_{10} 2 = 0.3010$.

3. An important property of the function e^x in its physical applications is that its rate of increase with respect to x is equal to the function itself (p. 199). If we define y as a function of x such that $\frac{dy}{dx}$ is always equal to y , show that if there is a series for y in ascending powers of x it must be

$$y = 1 + x + \frac{x^2}{1.2} + \frac{x^3}{1.2.3} + \dots$$

given that $y = 1$ when $x = 0$.

Note that this is the series for e^x given on p. 199.

4. We have $\frac{1 + \frac{x-1}{x+1}}{1 - \frac{x-1}{x+1}} = x$. Hence prove that

$$\log_e x = 2 \left\{ \frac{x-1}{x+1} + \frac{1}{3} \left(\frac{x-1}{x+1} \right)^3 + \frac{1}{5} \left(\frac{x-1}{x+1} \right)^5 + \dots \right\}$$

and calculate $\log_e 2$ and $\log_e 3$.

121. Exponential Values of Circular Functions.

We have shown that

$$\begin{aligned} \sin x &= x - \frac{x^3}{1.2.3} + \frac{x^5}{1.2.3.4} - \dots \\ \cos x &= 1 - \frac{x^2}{1.2} + \frac{x^4}{1.2.3.4} - \dots \end{aligned}$$

Comparing these series with the series

$$e^x = 1 + x + \frac{x^2}{1.2} + \frac{x^3}{1.2.3} + \frac{x^4}{1.2.3.4} + \frac{x^5}{1.2.3.4.5} + \dots$$

we see that it appears probable that there is some close relation between the exponential function e^x and the circular functions $\sin x$ and $\cos x$. The difficulty is that the signs are alternately positive and negative in the series for $\sin x$ and $\cos x$, while they are all positive in the series for e^x .

To remove this difficulty we may introduce the imaginary quantity $\sqrt{-1}$. If we use this quantity as if it were real in algebraical work, of which the result is real and can be tested, we find that the result is correct. It is usual to write $\sqrt{-1} = i$, so that $i^2 = -1$, $i^3 = -1 \times i = -i$, $i^4 = (-1)^2 = +1$, $i^5 = i$, and so on, all even powers of i being real.

If we substitute ix for x in the series for e^x , we get

$$\begin{aligned} e^{ix} &= 1 + ix - \frac{x^2}{1 \cdot 2} - \frac{ix^3}{1 \cdot 2 \cdot 3} + \frac{x^4}{1 \cdot 2 \cdot 3 \cdot 4} + \frac{ix^5}{1 \cdot 2 \cdot 3 \cdot 4 \cdot 5} - \dots \\ &= \left(1 - \frac{x^2}{1 \cdot 2} + \frac{x^4}{1 \cdot 2 \cdot 3 \cdot 4} - \dots\right) + i \left(x - \frac{x^3}{1 \cdot 2 \cdot 3} + \frac{x^5}{1 \cdot 2 \cdot 3 \cdot 4} - \dots\right) \\ &= \cos x + i \sin x \end{aligned}$$

Similarly $e^{-ix} = \cos x - i \sin x$.

From these equations we get

$$\cos x = \frac{e^{ix} + e^{-ix}}{2}$$

$$\sin x = \frac{e^{ix} - e^{-ix}}{2i}$$

EXAMPLE.—By means of these expressions for $\cos x$ and $\sin x$, show that $\sin 2x = 2 \sin x \cos x$.

121a. Complex numbers.—A number of the form $a + ib$ where a and b are any real numbers is called a complex number.

Since $\rho e^{i\alpha} = \rho \cos \alpha + i\rho \sin \alpha$, we may express any complex number in the form $\rho e^{i\alpha}$ by choosing ρ and α so that $\rho \cos \alpha = a$, $\rho \sin \alpha = b$, *i.e.* so that $\rho = \sqrt{a^2 + b^2}$, $\tan \alpha = \frac{b}{a}$ (p. 42).

EXAMPLE.—To express $3 + 7i$ in the form $\rho e^{i\alpha}$.

We have $\rho = 7.616$, $\alpha = 66.8^\circ = 1.166$ radian (Ex. 2, p. 42);

$$\therefore 3 + 7i = 7.616e^{1.166i}.$$

We are thus enabled to perform various arithmetical operations with complex numbers. The complete theory must be deferred to a later stage, but the student may note the following example:—

EXAMPLE.—Evaluate $\sqrt{3 + 7i}$.

We have as above $\sqrt{3 + 7i} = \sqrt{7.616e^{1.166i}} = \sqrt{7.616}e^{0.583i}$

$= 2.76 (\cos 0.583 + i \sin 0.583)$, taking the positive value of the square root,

$= 2.76 (\cos 33^\circ 24' + i \sin 33^\circ 24') = 2.76 (0.8348 + i \cdot 0.5505)$

$$= 2.301 + 1.52i$$

The student should verify by multiplication that the square of this expression is $3 + 7i$.

CHAPTER XV

MAXIMA AND MINIMA

(1.) Graphic Method.

122. The following table gives the density and the volume in cubic centimetres of 1 gm. of water at temperatures ranging from 0° C. to 100° C. :—

t° C.	Density.	Volume of 1 gm. in c.c.
0	0'999874	1'000127
1	0'999930	1'000070
2	0'999970	1'000030
3	0'999993	1'000007
4	1'000000	1'000000
5	0'999992	1'000008
6	0'999969	1'000032
7	0'999931	1'000069
8	0'999878	1'000122

We see that as t increases from 0° C., the density increases until $t = 4°$ C., and then diminishes, while the volume decreases until $t = 4°$ C. and then increases.

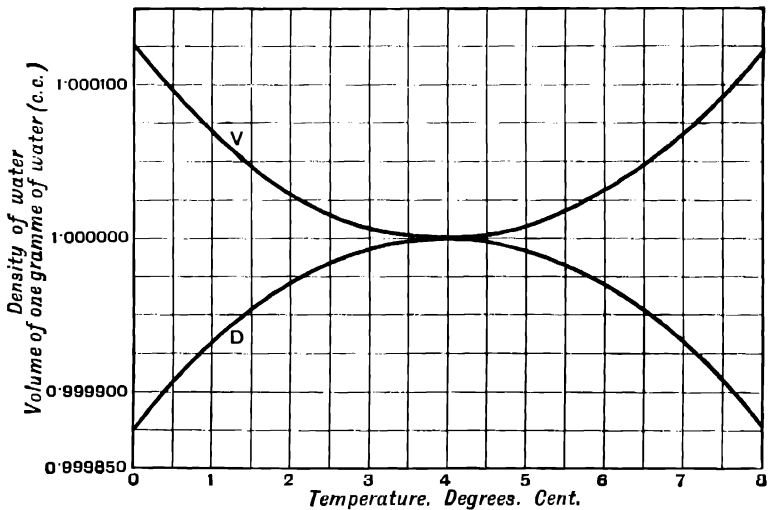

FIG. 91.

Plotting the curves **D** and **V** (Fig. 91) to represent the density and volume as functions of the temperature, we see that for the value 4° C. of t there is a point on **D** which is further from the axis of t than any point on the curve in its immediate neighbourhood. Similarly, for the same value of t there is a point on **V** which is nearer to the axis of t than any point on the curve in its immediate neighbourhood. We express this by saying that for the value 4° C. of t there is a maximum value 1.000000 of the density and a minimum value 1.000000 of the volume.

If y and x are two quantities connected in such a way that as x increases there is a value of x for which y stops increasing and begins to decrease, that value of y is called a **maximum** value.

If there is a value of x for which as x increases y stops decreasing and begins to increase, that value of y is called a **minimum** value.

When the values of y and x are found by experiment, as in the above example, we can sometimes detect the maximum and minimum values without plotting the curve, but the method of plotting has the following advantages:—

(1) When the maximum or minimum value is between two tabulated values the shape of the curve in the neighbourhood may indicate the position of the maximum or minimum value.

(2) It shows by the slope of the curve, near the maximum or minimum value, whether y approaches that value rapidly or slowly, and consequently what error will be made by taking a value of x , which is slightly greater or less than the true value.

123. Instead of having a tabulated list of values of y and x , found by experiment, we may have y expressed as a function of x by an equation.

If we plot a curve having values of y as ordinates, and values of x as abscissæ, we can find the maximum or minimum values by inspection of the curve.

EXAMPLE (1).—*To divide 16 into two parts so that their product is a maximum.*

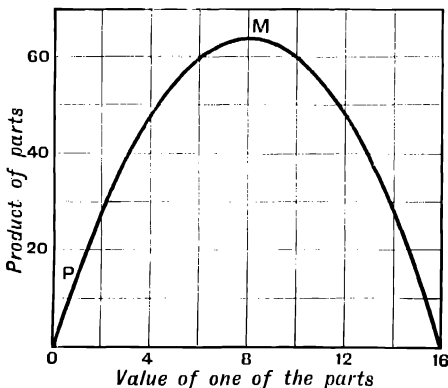

FIG. 9a.

Plot a curve for which values of one of the parts are abscissæ, and values of the product are ordinates. We see that the maximum product is 64, given by the point **M**, for which the two parts are each equal to 8.

EXAMPLE (2).—When is the sum of a number and the square of its reciprocal a minimum?

Let x be the number. Then we require a minimum value of $y = x + \frac{1}{x^2}$.

Plotting the curve to represent this equation, we see that y is a minimum, where $x = 1.46$.

The student should plot the curve.

EXAMPLE (3).—Find the maximum and minimum values of $x^3 - 6x^2 + 9x + 5$.

Plot the curve $y = x^3 - 6x^2 + 9x + 5$.

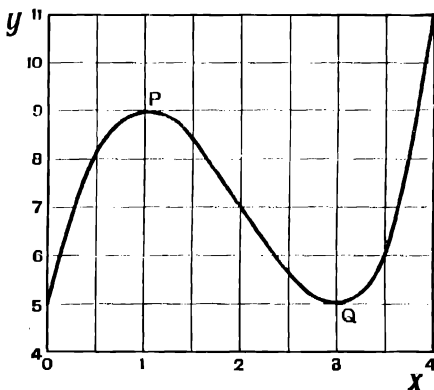

FIG. 93.

We see that there is a maximum value 9 where $x = 1$, and a minimum value 5 where $x = 3$.

Note that the maximum value of y is not the greatest possible value, but merely the greatest in the immediate neighbourhood on the curve; there are, of course, greater values when x is very large. Similarly, the minimum value 5 of y is not the least possible value.

EXAMPLE (4).—Find the maximum and minimum values of $y = 2 \sin t + \frac{1}{2} \sin 3t$ between $t = 0$ and $t = \pi$.

The curve representing y as a function of t has been drawn in Fig. 63.

We see that for the first half undulation, from $t = 0$ to $t = \pi$, there are two maximum values 1.8, where $t = 0.837$ radian and where $t = 2.204$ radians, and a minimum value 1.5, where $t = 1.57$ radians.

EXAMPLE (5).—If there are n voltaic cells each of EMF e volts and internal resistance r ohms, and if x cells are arranged in series and $\frac{n}{x}$ rows in parallel, the current that the battery will send through an external resistance R is given by

$$C = \frac{xe}{\frac{n^2}{x^2}r + R} \text{ amperes}$$

If there are 20 cells, $e = 1.9$ volts, $r = 0.2$ ohms, $R = 0.25$ ohms; how many cells must be in series to give the greatest possible current?

We have, substituting, $C = \frac{1.9x}{0.01x^2 + 0.25}$

By calculation we find the following corresponding values of C and x :—

x	1	20	10	4	7	5	6
C	7.31	8.93	15.2	18.52	17.97	19	18.68

We first calculate the positions of a few points to get a general idea of the shape of the curve, and then calculate values closer together in the neighbourhood of the maximum.

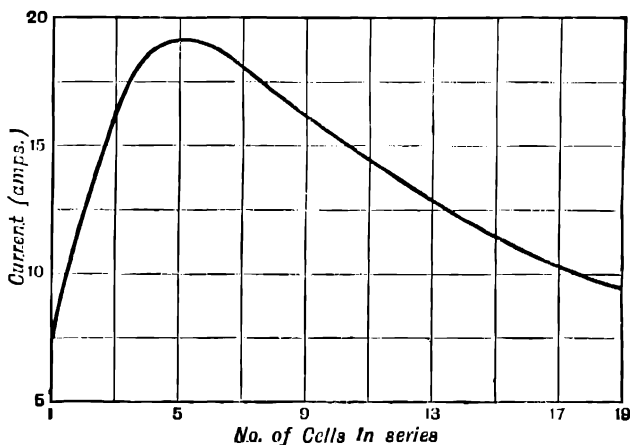

FIG. 94.

Plotting the above values of C and x , we get the curve, Fig. 94.

From the curve we see that the greatest current of 19 amperes is obtained when 5 cells are in series.

We may here note an advantage of the graphic method. We may wish to know, not only how many cells in series will give the maximum current, but also whether it will make more difference to have too many cells in series, or too few.

As the curve falls away from the maximum much more rapidly when x is diminished from the value 5 than it does when x is increased, we can see that it will make more difference if there are too few cells in series than it will if there are too many, as compared with the arrangement which gives the maximum current.

This method is valid, although there are only a few points on the above curve which correspond to any possible physical arrangement.

EXAMPLES.—LXIX.

1. Find a number such that the sum of the number and its reciprocal is a minimum.
2. The square of a number is added to 54 times the reciprocal of the number. Find the number so that the result may be a minimum.
3. Divide 1 into two parts so that twice the cube of one part together with 3 times the other part shall be a minimum.
4. A straight line 10 inches long is to be divided into two parts so that the cube of the length of one part together with three times the square of the length of the other part shall be a minimum. What are the lengths of the two parts?
5. The log of a number to base 10 is subtracted from the square of the number. For what number is the result a minimum?

6. Find the values of x for which the expression $2x^3 - 21x^2 + 60x + 5$ is a maximum or minimum.

7. Find the values of x for which the expression $x^3 - 3x^2 - 9x + 8$ is a maximum or minimum.

8. Find a value of x between 0 and 1.5 for which the expression $5.624 - 0.7935x - 1.21 \cos x$ is a minimum. In calculating take x in radians.

9. Find a value of θ between 0 and π for which the expression $r \sin \theta - \frac{r^2}{l} \cos 2\theta$ is a maximum for the case when $r = 0.5$, $l = 3.5$.

10. An open tank is to be constructed of sheet iron with a square base and vertical sides so as to contain 4 cubic ft. of water. Find the width and depth so that the least possible quantity of sheet iron may be used.

11. A circular filter paper is of diameter 11 cms. It is required to fold it into a cone. Find the height and cubic contents of this cone so that the latter may be the greatest possible.

12. An open cylindrical can is to be made to contain 255 cubic ins. Plot a curve to show the total area of tin plate that will be used for different values of the diameter of the base. Find the ratio of the height to the diameter of the base so that the least possible quantity of material may be used.

13. A rectangular sheet of tin 24 ins. by 18 ins. has four equal squares cut out at the corners, and the sides are then turned up so as to form a rectangular box. What must be the size of the squares cut out so that the cubical contents of the box may be as great as possible?

14. Describe a circle of radius 3 ins. Inscribe rectangles in this, having their sides in various ratios. Plot the areas of the rectangles and the length of one side. Show that the greatest rectangle which can be inscribed in the circle is a square.

15. It is known that the weight of coal in tons consumed per hour in a certain vessel is $0.3 + 0.001v^2$ where v is the speed in knots. The wages, interest on cost of vessel, etc., are represented by the value of 1 ton of coal per hour. What value of v makes the total cost of a voyage of 1000 nautical miles a minimum?

(Board of Education Examination, 1902.)

16. The strength of a rectangular beam of given length, loaded and supported in a given way, is proportional to the breadth of its cross-section multiplied by the square of the depth.

Find the breadth and depth of the cross-section of the strongest rectangular beam which can be cut out of a cylindrical tree trunk 1 foot in diameter.

Take various values of the breadth, and measure the corresponding depth of the beam from a figure drawn to scale. Plot a curve to show the corresponding values of the strength. Then find more exactly by calculation the values of the breadth, depth, and strength, near the case of maximum strength; and plot the corresponding portion of the curve on a larger scale.

17. The stiffness of a beam varies as the breadth and the cube of the depth. Find in the same way as in the last example the breadth which gives maximum stiffness.

18. As in example 5 worked out in full above, find the maximum current and the number of cells in series when there are 48 cells each of E.M.F. 1.4 volt and 3 ohms resistance, and the external resistance is 16 ohms.

19. A battery of internal resistance r and E.M.F. ϵ sends a current through an external resistance R . The power given to the external circuit is

$$W = \frac{R\epsilon^2}{(R+r)^2}$$

If $\epsilon = 3.3$, and $r = 1.5$, with what value of R will the greatest power be given to the external circuit.

20. The power given to an external circuit by a generator of internal resistance r , and E.M.F. ϵ , when the current is C , is $W = C\epsilon - C^2r$. Find for what current this is a maximum for the case when $\epsilon = 20$ volts, $r = 1.8$ ohms.

21. A and B are two points on the same side of a plane mirror CD . A, B, C , and D are in a plane perpendicular to the surface of the mirror. A ray of light starts from A , is reflected by the mirror at P , and passes to B . Plot a curve to show the total length of the path of the ray of light for different positions of P in CD , and show by

means of this curve that the path is the shortest possible when **AP** and **PB** make equal angles with the mirror. **AN**, **BM** are perpendicular to **CD**. In your figure take **AN** = 25 units, **BM** = 15, **MN** = 30. Draw the figure on squared paper, and erect ordinates from each supposed position of **P** in **CD** to represent the total length of the path of the ray corresponding to that position.

22. Light passes from a point **A** in air to a point **B** in glass. **A** and **B** are in a plane perpendicular to the surface of the glass, cutting the surface in a straight line **CD**. A ray of light passes through the air with a velocity of 300,000 kms. per second, and through glass with a velocity of 182,000 kms. per second, crossing **CD** at the point **P**.

Plot a curve to show the time taken by the light to pass from **A** to **B** for different positions of **P** in **CD**.

AN and **BM** are perpendiculars drawn from **A** and **B** to **CD**. Take **AN** = 10 cms., **BM** = 15 cms., **MN** = 20 cms. Verify that the least possible time is occupied by the ray of light in passing from **A** to **B** when $\sin \text{PAN} : \sin \text{PBM} = \text{velocity in air} ; \text{velocity in glass}$.

23. A weight **W** is being pulled along a rough horizontal surface by means of a rope inclined at an angle θ to the surface. The pull required is equal to $\frac{\mu W}{\cos \theta + \mu \sin \theta}$ where μ is the coefficient of friction. Find the angle for which the pull required is a minimum in the case where $\mu = 0.6$.

24. A certain patented article costs 1s. 6d. to make. The following table gives the number sold at different prices :—

Price . . .	2s. 0d.	2s. 6d.	3s. 0d.	3s. 6d.	4s. 0d.	4s. 6d.
No. sold .	3600	3100	2640	2080	1300	700

Find the price at which it must be sold so that the total profit may be a maximum.

124. (II.) **Maxima and Minima by Differentiation.**—The maxima and minima values of a function may be found by means of the differential calculus.

Consider the curve, Fig. 93, p. 227, representing the function $y = x^3 - 6x^2 + 9x + 5$.

Imagine a point (x, y) to move along the curve in the direction of increasing x . Then, as the point passes through the maximum **P**, y stops increasing and begins to diminish, i.e. $\frac{dy}{dx}$, which measures the rate of increase of y , changes from positive to negative by passing through the value 0.

Similarly, $\frac{dy}{dx} = 0$ at the minimum **Q**, changing from negative to positive.

Otherwise, we have seen that $\frac{dy}{dx}$ measures the slope of the tangent to the curve measured with respect to the axis of x . At the points **P** and **Q** the tangent is parallel to **Ox**, and its slope is zero, i.e. $\frac{dy}{dx} = 0$.

We thus get the following method to find the maximum and minimum values of y when expressed as a function of x .

Find $\frac{dy}{dx}$. Then the equation $\frac{dy}{dx} = 0$ gives values of x for which y is a maximum or a minimum.

To distinguish between maximum and minimum values: Suppose a

point (x, y) to move along the curve in the direction of increasing x , through a maximum such as P , where $\frac{dy}{dx} = 0$. Then the tangent to the curve drawn through this moving point is turning round the point in the same direction as the hands of a clock, and the angle which this tangent makes with Ox is decreasing.

Therefore $\frac{dy}{dx}$ is decreasing, and $\frac{d^2y}{dx^2}$, which measures the rate of increase of $\frac{dy}{dx}$, is negative. Similarly at a minimum, such as Q , the tangent is turning in the opposite direction to the hands of a clock, the angle which it makes with Ox is increasing, and therefore $\frac{dy}{dx}$ is increasing and $\frac{d^2y}{dx^2}$ is positive.

Thus, to tell whether a value of x , found by putting $\frac{dy}{dx} = 0$, gives a maximum or a minimum, differentiate again the expression for $\frac{dy}{dx}$ so as to get $\frac{d^2y}{dx^2}$ and substitute the value of x found.

If the result is negative y is a maximum, if it is positive y is a minimum for that value of x .

In the special case, when $\frac{d^2y}{dx^2} = 0$, y is neither a maximum nor a minimum, but this case need not be considered at the present stage.

We shall now consider some of the examples already solved by the graphic method in § 123.

EXAMPLE (1).—To divide 16 into two parts so that their product is a maximum.

Let x be one part, then $10 - x$ is the other part, and their product $y = x(16 - x) = 16x - x^2$.

$$\frac{dy}{dx} = 16 - 2x$$

For a maximum or minimum $\frac{dy}{dx} = 0$

$$\therefore 16 - 2x = 0, x = 8$$

Also $\frac{d^2y}{dx^2} = -2$, and since this is negative for all values of x , y can only have a maximum value.

Comparing this result with the curve Fig. 92, we see that the condition that $\frac{d^2y}{dx^2}$ is negative expresses that the slope is always decreasing as we pass along the curve in the direction of increasing x .

EXAMPLE (2).—For what number is the sum of the number and the square of its reciprocal a minimum?

$$\text{As before } y = x + \frac{1}{x^2}$$

$$\frac{dy}{dx} = 1 - \frac{2}{x^3}$$

For a maximum or minimum value $\frac{dy}{dx} = 0$

$$\therefore 1 - \frac{2}{x^3} = 0, x = \sqrt[3]{2} = 1.26$$

which is the same as the value found from the curve.

EXAMPLE (3).—To find the maximum and minimum values of

$$y = x^3 - 6x^2 + 9x + 5$$

$$\frac{dy}{dx} = 3x^2 - 12x + 9$$

∴ for a maximum or minimum value

$$3x^2 - 12x + 9 = 0$$

$$\therefore x = 3 \text{ or } 1$$

$$\text{Also } \frac{d^2y}{dx^2} = 6x - 12$$

For $x = 3$, $\frac{d^2y}{dx^2}$ is positive, and therefore y is a minimum.

For $x = 1$, $\frac{d^2y}{dx^2}$ is negative, and therefore y is a maximum.

Substituting the values 3 and 1 for x , we get 5 as the minimum, and 9 as the maximum, value of y .

These results agree with those already obtained by plotting.

In this case we might have distinguished between the maximum and minimum values by substitution, but the above method is more general.

EXAMPLE (4).—We shall use the method of this paragraph to find the arrangement of a number of cells to give the maximum current with the data given in example 5, p. 227.

$$\text{We have } C = \frac{1.9x}{0.01x^2 + 0.25} = \frac{1.9}{0.01x + \frac{0.25}{x}}$$

The value of this fraction will be a maximum when its denominator is a minimum.

$$\text{Let } y = 0.01x + \frac{0.25}{x}$$

$$\frac{dy}{dx} = 0.01 - \frac{0.25}{x^2}$$

∴ for a minimum value

$$0.01 - \frac{0.25}{x^2} = 0$$

$$\therefore x^2 = 25, \text{ and } x = 5$$

i.e. there are 5 cells in series, and $C = 19$, as we find by the graphic method.

It is evident from the physical conditions that this value of C is a maximum and not a minimum.

EXAMPLE (5).—The following case occurs in studying the flow of air through a small opening.

For what value of x is $x^{\frac{2}{7}} - x^{1+\frac{1}{7}}$ a maximum, γ being 1.4. Plot the values near the maximum value.
(Board of Education Examination, 1902.)

$$\text{We have } y = x^{\frac{2}{7}} - x^{1+\frac{1}{7}} = x^{\frac{2}{7}} - x^{\frac{8}{7}} = x^{\frac{2}{7}} - x^{\frac{10}{7}} - x^{\frac{12}{7}}$$

$$\frac{dy}{dx} = \frac{10}{7}x^{\frac{5}{7}} - \frac{12}{7}x^{\frac{6}{7}} = \frac{1}{7}x^{\frac{5}{7}}(10 - 12x^{\frac{1}{7}})$$

For a maximum or minimum value of y , $\frac{dy}{dx} = 0$

$$\therefore x = 0, \text{ or } 10 - 12x^2 = 0$$

The case $x = 0$ is evidently not a maximum value.

$$\text{When } 10 - 12x^2 = 0, \quad x = \left(\frac{10}{12}\right)^{\frac{1}{2}} = 0.528$$

We know from physical reasons that this value of x gives a maximum value of y .

The student should satisfy himself that this is so by plotting the value of y for $x = 0.528$, and for two values of x respectively a little greater and a little less than 0.528.

EXAMPLES.—LXX.

Find the values of x for which the following expressions have their maximum and minimum values:—

1. $2x^3 - 13x^2 + 24x + 18$.

2. $2x^3 - 9x^2 - 24x + 12$.

3. $x^4 - 12x^3 + 28x^2 + 40$.

4. $3x^4 - 16x^3 - 6x^2 + 48x + 17$.

Work Examples LXIX., with the exception of numbers 21, 22, and 24, by the method of this chapter.

5. It was shown in example 2, p. 218, that in measuring an electrical resistance by means of a bridge wire the percentage error in the result due to a given small error in the position of the sliding key is proportional to $\frac{l}{x(l-x)}$, where x is the variable distance of the key from one end of the wire, and l the length of the wire.

Show that the percentage error is a minimum when the proportional arms are equal, *i.e.* when the key is in the middle of the bridge wire.

Plot a curve to illustrate your result, taking $l = 120$ cms., $\omega = 5$ ohms, and x varying from 0 to 120 cms.

6. In measuring an electric current by means of a tangent galvanometer, the percentage error due to a given small error in the reading is proportional to $\tan x + \frac{1}{\tan x}$. Show that this is a minimum when $x = 45^\circ$.

CHAPTER XVI

INDEFINITE INTEGRALS

125. WE have already shown how to find the rate of increase of various functions of a variable.

We often require to perform the converse operation, *i.e.* having given the rate of increase of a function to find the function. The function of x whose rate of increase is equal to y , is called the indefinite integral of y with respect to x , and is denoted by the symbol $\int y dx$.

For example, we know that the rate of increase of x^6 with respect to x is $6x^5$, and therefore the integral of $6x^5$ with respect to x is x^6 , or $\int 6x^5 dx = x^6$.

The two equations $\frac{d}{dx} \cdot x^6 = 6x^5$ and $\int 6x^5 dx = x^6$ are two different ways of expressing the same thing.

We know that $\frac{d}{dx} e^{3x} = 3e^{3x}$, and $\therefore \int 3e^{3x} dx = e^{3x}$.

We know that $\frac{d}{dx} \{\sin(2x + 1)\} = 2 \cos(2x + 1)$, $\therefore \int 2 \cos(2x + 1) dx = \sin(2x + 1)$.

In the same way it follows

$$\int x^5 dx = \frac{1}{6} x^6$$

because x^6 is the result of differentiating $\frac{1}{6} x^6$.

So also

$$\int e^{3x} dx = \frac{1}{3} e^{3x}$$

$$\int \cos(2x + 1) dx = \frac{1}{2} \sin(2x + 1)$$

Thus we see that every result in differentiation gives a corresponding result in integration.

EXAMPLES.—LXXI.

Find the values of the following expressions, and prove by differentiation that your results are correct:—

- | | | | |
|-------------------------------|-------------------------------|---------------------------------|-------------------------------|
| 1. $\int 3x^2 dx.$ | 2. $\int x^2 dx.$ | 3. $\int x^4 dx.$ | 4. $\int x^n dx.$ |
| 5. $\int 5e^{3x} dx.$ | 6. $\int e^{3x} dx.$ | 7. $\int 3e^{3x} dx.$ | 8. $\int ae^{bx} dx.$ |
| 9. $\int \cos x dx.$ | 10. $\int 3 \cos(3x + 1) dx.$ | 11. $\int \cos(3x + 1) dx.$ | 12. $\int 2 \cos(3x + 1) dx.$ |
| 12. $\int 2 \cos(3x + 1) dx.$ | 13. $\int a \cos(bx + c) dx.$ | 14. $\int (-\sin x) dx.$ | 15. $\int \sin x dx.$ |
| 15. $\int \sin x dx.$ | 16. $\int 2 \sin(2x - 3) dx.$ | 17. $\int \sin(2x - 3) dx.$ | 18. $\int 5 \sin(2x - 3) dx.$ |
| 18. $\int 5 \sin(2x - 3) dx.$ | 19. $\int a \sin(bx + c) dx.$ | 20. $\frac{d}{dx} \log(x + 5).$ | |

21. $\int \frac{1}{x+5} dx$, which is usually written $\int \frac{dx}{x+5}$.

22. $\int \frac{dx}{x}$.

23. $\int \frac{A dx}{x+b}$.

126. In working through the above examples the student has obtained number of standard integrals corresponding to the differential coefficients previously obtained. We may here collect them for reference.

$$\int x^n dx = \frac{x^{n+1}}{n+1} \text{ except when } n = -1$$

$$\int a e^{bx} dx = \frac{a}{b} e^{bx}$$

$$\int a \sin (bx + c) dx = -\frac{a}{b} \cos (bx + c)$$

$$\int a \cos (bx + c) dx = \frac{a}{b} \sin (bx + c)$$

$$\int \frac{dx}{x} = \log_e x$$

$$\int \frac{A dx}{x+b} = A \log_e (x+b)$$

127. Arbitrary Constant.

We have $\frac{d}{dx} x^7 = 7x^6$, $\frac{d}{dx} (x^7 + 5) = 7x^6$, $\frac{d}{dx} (x^7 - 3) = 7x^6$.

Thus $\int 7x^6 dx = x^7$, or $x^7 + 5$, or $x^7 - 6$, or, in general, $x^7 + C$

where C is any constant, because all expressions of the form $x^7 + C$ have the same differential coefficient $7x^6$.

In the same way, each of the integrals in the above list is intermediate to the extent of an arbitrary constant. Thus the full expression for $\int x^n dx$ is $\frac{x^{n+1}}{n+1} + C$. We usually omit the constant, but it sometimes has to be taken into account.

128. EXAMPLES.—

$$\int 3x^{1.6} dx = \frac{3}{2.5} x^{2.6} = 1.2x^{2.6}.$$

$$\int \frac{6}{x^3} dx = \int 6x^{-3} dx = -\frac{6}{2} x^{-2} = -\frac{3}{x^2}.$$

$$\int \frac{dv}{v^{1.37}} = \int v^{-1.37} dv = \frac{v^{-0.37}}{-0.37} = -\frac{2.7}{v^{0.37}}.$$

$$\begin{aligned} \int 2 \sin (600t + 0.5236) dt &= -\frac{2}{600} \cos (600t + 0.5236) \\ &= -0.0033 \cos (600t + 0.5236). \end{aligned}$$

$$\int 3e^{2u} du = 1.5e^{2u}.$$

$$\int 3.2 \cos (2\theta - 1.7) d\theta = 1.6 \sin (2\theta - 1.7).$$

$$\int cx^m dx = \frac{cx^{m+1}}{m+1}.$$

$$\int a \sin (bt + cx) dt = -\frac{a}{b} \cos (bt + cx),$$

$$\int a \sin (bt + cx) dx = -\frac{a}{c} \cos (bt + cx).$$

The symbols dx and dt in the last two examples show whether x or t is considered as variable.

EXAMPLE.—Find $\int p dv$ having given that $p v^{10} = C$.

$$\text{We have } p = \frac{C}{v^{10}}$$

$$\therefore \int p dv = \int \frac{C}{v^{10}} dv = \frac{C v^{-9}}{-9} = -\frac{10C}{9} v^{-9}$$

We have already shown that a sum or difference can be differentiated term by term. It follows that a sum or difference can be integrated term by term. Thus—

$$\int (5x^2 - 3x + 2) dx = \frac{5}{3} x^3 - \frac{3}{2} x^2 + 2x$$

$$\int \{a \sin (bt + c) + kt + g\} dt = -\frac{a}{b} \cos (bt + c) + \frac{k}{2} t^2 + gt$$

EXAMPLES.—LXXII.

Evaluate the following :—

1. $\int x^3 dx.$

2. $\int x^{10} dx.$

3. $\int \frac{dx}{x^2}.$

4. $\int \frac{dx}{x^5}.$

5. $\int \sqrt{x} dx.$

6. $\int x^{1/6} dx.$

7. $\int \frac{dx}{x^{9/10}}.$

8. $\int \frac{dx}{x^{1/12}}.$

9. $\int 3^x dx.$

10. $\int dx.$

11. $\int c dx.$

12. $\int u^6 du.$

13. $\int \frac{3^x dy}{y^3}.$

14. $\int \frac{du}{u}.$

15. $\int \frac{du}{u^4}.$

16. $\int 4u^7 du.$

17. $\int \frac{du}{u^{1.004}}.$

18. $\int \sqrt{u}.$

19. $\int \frac{dv}{v^{1/14}}.$

20. $\int \frac{dy}{y^{3/2}}.$

21. $\int \frac{5dv}{v}.$

22. $\int ct^6 dt.$

23. $\int 2e^{3x} dx.$

24. $\int e^{2x} dx.$

25. $\int 3e^x dt.$

26. $\int 1.36e^{-1.2u} dy.$

27. $\int ae^{-\frac{k}{2}t} dt.$

28. $\int \sin (x - 3) dx.$

29. $\int \cos (x - 2) dx.$

30. $\int 2 \cos (1 - x) dx.$

31. $\int 2 \sin u du.$

32. $\int 3 \cos y dy.$

33. $\int 4 \cos (3x + 2) dx.$

34. $\int 3 \sin (2x - 1) dx.$

35. $\int 1.3 \sin (2.7t - 1.5708) dt.$

36. $\int 1.3 \sin (2.5\theta + 6) d\theta.$

37. $\int 2.3 \cos (1 - 3\theta) d\theta.$

38. $\int A \sin (2\pi ft + e) dt.$

39. $\int A r \cos (\gamma t + e) dt.$

40. $\int \pi y^2 dx$ when $y = mx$, and also when $y^2 = 4ax$.

41. $\int mx^2 dy$ where $m = \frac{k}{y}$ and $x = by$.

42. $\int a \sin (bt + cx) dx$ where $t = 5x + 2$.

43. $\int \frac{\rho_1 v_1 \gamma dv}{v^7}$ where ρ_1, v_1, γ are constants.

44. $\int xy dx$ when $y = bx + c$.

45. $\int x^2 y dx$ when $y = mx + c$.

46. $\int p dv$ when $pv^\gamma = C$.

47. $\int p dv$ when $pv^2 = C$
 (1) when $s = 1.37$, (2) when $s = 1$, (3) when $s = 0.8$.
48. $\int \frac{Ax dx}{A dx^2}$ where $A = \pi y^2$, and $y = mx$.
49. If $\frac{dy}{dx} = 3x^2 + 2x - 1$, find y . 50. If $\frac{dy}{dx} = 2 \sin 2x + 4$, find y .
51. $\frac{dy}{dx} = 3e^{2x} + 5$, find y .
52. $\frac{dy}{dx} = \frac{1}{1+x} + 1.2x^3 + \sin(3x+1) + 2.6$, find y .

Evaluate the following :—

53. $\int (3x^2 - 2x + 4) dx$. 54. $\int (4t^2 - 3t^2 + 2t - 1) dt$.
55. $\int (3t^2 + 4t - 5) dt$. 56. $\int (x^2 + 3x - 4x^{1/3} - 2) dx$.
57. $\int (s^3 - s^{0.3} - 3.1s^2 - \frac{2}{s^2} - 5) ds$. 58. $\int (x^{1/3} - ax^2 + b\sqrt{x} + c) dx$.
59. $\int (5u^3 - a \sin(c + du) + b \cos(a + cu) + 3e^{1/3u} - e^{5a}) du$.
60. $\int \left\{ 6a \sin(b - 3ct) - 5ce^{-2.6bt} - \frac{1.3c}{bt} - c^{\frac{1}{2}} t^{\frac{1}{2}} \right\} dt$.
61. $\int \pi y^2 x dx$ given $x^2 + y^2 = a^2$.
62. If $y = u^3 - 3u^2 + 2e^{3u}$, find $\frac{dy}{du}$ and $\int y du$.
63. If $\frac{d^2y}{dx^2} = x^3 + 5$, find $\frac{dy}{dx}$ and y .
64. If $\frac{d^2p}{dv^2} = -\frac{Cv}{v^{3+1}}$, find the equation connecting p and v .

65. If y is the deflection at distance x from the fixed end of a uniform beam of length l , fixed at one end and loaded with a weight W at the other; then, if we neglect the weight of the beam

$$\frac{d^2y}{dx^2} = (l - x) \frac{W}{EI}$$

E and I are constants depending on the material and shape of the beam. It is known that the deflection y and slope $\frac{dy}{dx}$ are zero at the fixed end where $x = 0$. Find an expression for y in terms of x .

NOTE.—The arbitrary constants of integration may be found from the given conditions at the fixed end.

66. For a beam carrying a uniformly distributed load w per unit length, and fixed at one end,

$$\frac{d^2y}{dx^2} = -\frac{w}{2EI}(l - x)^2$$

Find y in terms of x .

67. Find the equation to a curve whose slope at any point is equal to the value of x^2 for that point. Verify by plotting the curve from the equation for the case when the curve passes through the point $(1, 2)$ and measuring the slope.

CHAPTER XVII

DEFINITE INTEGRALS—GRAPHIC METHOD

129. An Area as the Limit of a Sum.

Let AB be a portion of a curve representing y as a function of x ; AM and BN the extreme ordinates, and let $OM = a$, $ON = b$.

Then, to find the area $ABNM$ by the mean ordinate method, we divide the interval MN into any number of parts and thus divide the figure into strips. Although it is not essential, we shall take the strips as being of equal width. Let δx be the width of one of the strips. Then we multiply the width δx of each strip by the ordinate y at its mid-point, and thus obtain an approximation to the whole area $ABNM$ as the sum of a number of terms $y\delta x$ from $x = a$ to $x = b$. We denote this sum by the symbol $\sum_a^b y\delta x$.

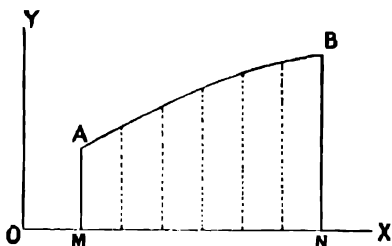

FIG. 95.

In working examples on the graphic method of finding areas we found that we got more and more accurate results as we divided MN into a greater and greater number of intervals δx , and consequently diminished the size of δx .

The result can be made as accurate as we please by dividing MN up with sufficient fineness into equal intervals δx .

We express this in mathematical language by saying that the sum $\sum_a^b y\delta x$ approaches a definite limiting value as δx approaches the value 0. This limiting value defines the true area of the figure $ABNM$.

130. Definite Integral as the Limit of a Sum.—We use the symbol $\int_a^b ydx$ to denote the limit of the sum $\sum_a^b y\delta x$ as δx approaches the value 0.

If we have given a series of corresponding values of y and x between $x = a$ and $x = b$, we may find the approximate value of $\int_a^b ydx$ as follows:—

Plot a curve from the given values of y and x . Then the area enclosed by this curve, the axis of x , and the ordinates at $x = a$ and $x = b$ is equal to $\int_a^b ydx$, and may be found approximately by any of the practical methods for finding areas.

$\int_a^b ydx$ is called the definite integral of y with respect to x between the limits a and b .

The connection between the definite integral and the indefinite integral already treated, will be shown in the following chapter.

NOTE.—The student may find some difficulty in understanding the reasoning of these two paragraphs; but he will probably find the difficulty removed in the following worked examples. In reading these he should draw all figures for himself, and verify all measurements and calculations.

EXAMPLE (1).—The following are corresponding values of y and x . Find the value of $\int_1^6 y dx$:—

x	1	2	2.7	3.8	4.7	5.1	5.7	6
y	0	1.87	2.89	3.2	2.85	2.23	1.7	1

Plotting the given values of x and y , we get the curve, Fig. 96.

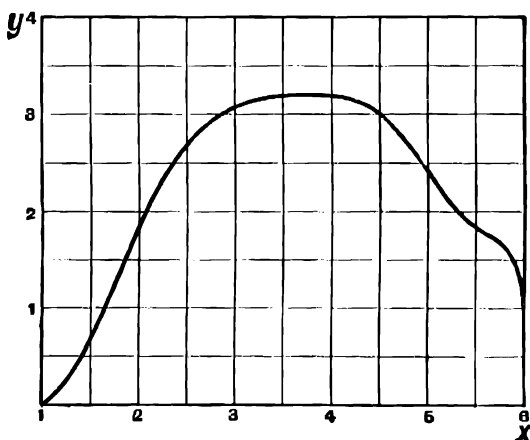

FIG. 96.

The area enclosed by this curve, the axis of x , and the limiting ordinates at $x = 1$ and $x = 6$ is found to be 11.3.

We have shown that $\int_1^6 y dx$ is equal to this area,

$$\therefore \int_1^6 y dx = 11.3$$

EXAMPLE (2).—The following are corresponding values of x and y . Find the value of $\int_2^8 \pi y^2 dx$.

x	2	3	3.5	4.3	5.3	6.4	8
y	0.77	1.2	1.26	1.18	0.8	0.33	0.1
πy^2	1.86	4.52	4.99	4.38	2.02	0.34	0.03

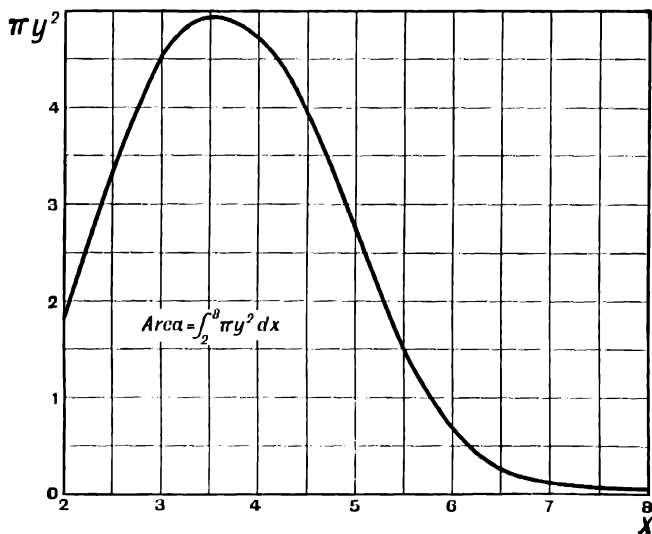

FIG. 97.

By calculation we find the values of πy^2 given in the third line.
 Plotting πy^2 and x we get the curve (Fig. 97).
 The area under this curve is found by Simpson's rule to be 13.85,

$$\therefore \int_2^8 \pi y^2 dx = 13.85$$

EXAMPLES.—LXXIII.

1. The following are corresponding values of y and x . Find the value of $\int_{1.2}^{6.2} y dx$.

x	1.2	1.6	1.9	2.5	3.5	4.2	4.9	5.9	6.2
y	5.00	4.24	3.80	3.34	3.06	3.14	3.34	3.75	3.91

2.

x	4	6	8	10
y	64	214	508	994

Find the values of $\int_4^{10} y dx$ and $\int_4^8 y dx$.

3.

x	1	3	6	8	10
y	5	29	215	509	995

Find the values of $\int_1^2 y dx$, $\int_1^3 y dx$, $\int_1^6 y dx$, $\int_1^8 y dx$, $\int_1^{10} y dx$.

Plot a curve to show the value of $\int_1^x y dx$ for any value of the upper limit x from $x = 1$ to $x = 10$.

The following are corresponding values of y and x :—

x	2.80	3.57	4.13	4.77	5.31	5.90
y	8.365	9.445	10.160	10.920	11.520	12.145

Find the values of the following integrals :—

4. $\int_{2.8}^{5.9} y^2 dx.$

5. $\int_{2.8}^{5.9} xy dx.$

6. $\int_{2.8}^{5.9} xy^2 dx.$

7. $\int_{2.8}^{5.9} y \cdot x^2 dx.$

8. $\int_{2.8}^{5.9} (1.2x^2 + 2.3x - 3) dx.$

131. Work done by a Variable Force.—We know that if a constant force F moves a body through a distance s in its own direction the work done is equal to $F \cdot s$.

Consider now a body, such as the piston of a steam-engine, which is pushed forwards by a force which varies gradually throughout the stroke.

As the force is not the same in two successive portions of the stroke, we cannot now find the work done by multiplying the force by the total distance moved.

If, however, we suppose the force, instead of changing gradually, to change by short steps; in other words, if we divide the stroke s into a number of small portions each equal to δs , and suppose the force during each step δs to remain constant and equal to its actual value F at some point of that step, then the work done in moving through any step δs is $F \delta s$.

We obtain an approximation to the value of the work done in the whole

stroke by adding together the values of $F\delta s$ for all the steps; i.e. if s_1 and s_2 are the distances of the piston from some fixed point on the line of its motion at the beginning and end of the stroke, $\sum_{s_1}^{s_2} F\delta s$ is approximately equal to the work done in the stroke from s_1 to s_2 .

As in finding an irregular area, we get a more and more accurate result by imagining the stroke cut up into smaller and smaller steps, and we may say as before that the work done in the stroke from s_1 to s_2 , when the force F is variable, is the limit which $\sum_{s_1}^{s_2} F\delta s$ approaches as δs approaches the value 0.

Now we have used the symbol $\int_{s_1}^{s_2} F ds$ to denote the limit of the sum $\sum_{s_1}^{s_2} F\delta s$.

$$\therefore \text{the work done} = \int_{s_1}^{s_2} F ds$$

We may find the value of this integral by plotting a curve in which the ordinate and abscissa are corresponding values of F and s from $s = s_1$ to $s = s_2$. The area under this curve then gives the value of $\int_{s_1}^{s_2} F ds$, which is equal to the work done.

This is the principle of the use of the indicator diagram of a steam or gas engine to find the work done in the stroke and the average pressure. By mechanical means the engine is made to trace automatically the curve showing the value of the pressure in the cylinder at different parts of the stroke.

From the area of this diagram the work done during the stroke can be found.

Similarly, if the connection between the force F and the time t is given, $F\delta t$ is the impulse or gain in momentum during the short interval of time δt , and $\int_{t_1}^{t_2} F dt$ is the total gain in momentum between the times t_1 and t_2 .

EXAMPLE (1).— P is the resultant pressure on the piston of a steam-engine at distance s from the beginning of the stroke. Find the work done as the piston moves forwards through the stroke of 20".

s inches	0	1	4	6	8	11.5	15	19	20
P lbs.	38000	38500	38500	35500	27500	19000	15700	11000	3850

$$\text{Work done} = \int_0^{20} P ds \text{ ft. lbs.}$$

Plotting P and s we get the curve **BC** (Fig. 98).
The area **ABCD** is found to be 494600.

$$\therefore \int_0^{20} P ds = 494600$$

$$\text{and the work done} = \int_0^{20} P ds = 41200 \text{ ft. lbs.}$$

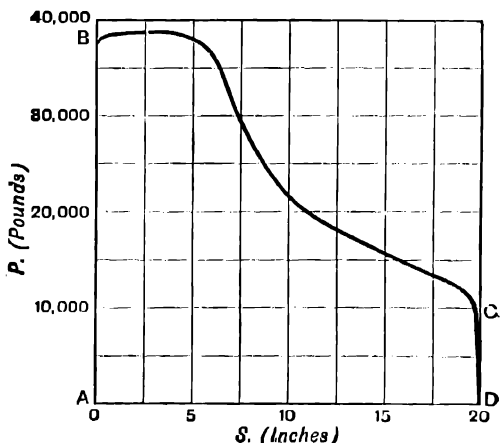

FIG. 98.

EXAMPLE (2).—A car weighs 10 tons. It is drawn by the pull P lbs., varying in the following way, t being the time in seconds from starting.

P	1020	980	882	720	702	650	713	722	805
t	0	2	5	8	10	13	16	19	22

The retarding force of friction is constant, and equal to 410 lbs. Find the speed of the car at the time 22 seconds from rest.

(Board of Education Examination in Applied Mechanics, 1902.)

A force of 410 lbs. is required to overcome the friction. The remaining force $P - 410$ is available for getting up the speed of the car.

The total impulse or gain of momentum from rest is equal to $\int_0^{22} (P - 410)dt$

Plotting the values of $P - 410$ and t , we get the curve shown in the figure.

Note that, although we require the whole area between the curve and the axis for which $P - 410 = 0$, we need not include the whole of this area in the figure. In finding the area we may reckon the whole ordinates from the axis $P - 410 = 0$, although only their upper portions are actually shown in the figure; e.g. at the point A we reckon the ordinate in calculating the area to be 472.

The value of $\int_0^{22} (P - 410)dt$ is found by Simpson's Rule to be 8100.

This is the momentum at 22 seconds from rest.

$$\text{Mass of car} = \frac{22400}{32 \cdot 2}$$

$$\text{speed} = \frac{\text{momentum}}{\text{mass}} = \frac{8100 \times 32 \cdot 2}{22400} = 11 \cdot 7 \text{ ft. per sec.}$$

NOTE.— We use the system of engineering units in which 32·2 lbs. is taken as the unit of mass.

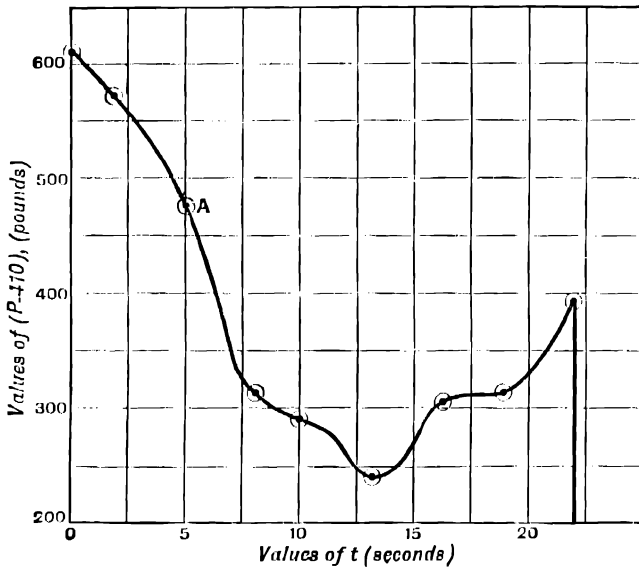

FIG. 99.

EXAMPLES.—LXXIV.

1. P lbs. is the resultant pressure on the piston of an engine at distance s from the beginning of its stroke.

Find the work done as s increases from 0 to 10.

P	23000	23000	15500	8400	5500	3700
s	0	1·4	4	6	8	10

2. p is the pressure of a gas at volume v . The work done in expansion from volume v_1 to volume v_2 is $\int_{v_1}^{v_2} p dv$. Find the work done as the gas expands from volume 1 to volume 9.

p	200	57	22	12·6	7·2
v	0·8	2	4	6	9

3. p is the pressure of a quantity of steam at volume v .

p	65.7	31.3	19.8	14.3	11.5
v	2	4	6	8	10

Find the work done as the steam expands from volume 2 to volume 10.

4. From the following data find the work done in expansion from volume 4 to volume 10.

v	4	5	6	8	10
p	71.7	49.6	38.5	31.5	28.7

5. A force moves a body along a straight line in its own direction. F is the value of the force at a distance s from the starting-point.

Find the work done in moving the body a distance of 1.85 ft.

F lbs.	7	90	207	290	225	180	0
s feet	0	0.25	0.5	0.9	1.2	1.5	1.85

6. P is the resultant force at time t on a portion of a machine which moves along a straight line. Its weight is 270 lbs. If it has a velocity of 2 ft. per second at time $t = 0$, what is its velocity at time $t = 0.3$ seconds.

t seconds	0	0.05	0.1	0.125	0.15	0.20	0.25	0.3
P lbs.	0	307	428	440	425	330	175	0

7. v is the speed of a car at time t from rest.

t seconds	0	5	10	15	20	25	30
v ft. per sec.	0	3.7	7.5	10.85	12.95	13.7	14

Find the distance s travelled from rest in 30 seconds

$$s = \int_0^{30} v dt.$$

Also find the distance travelled from rest in 16.5 seconds.

8. The following table gives the acceleration a of the reciprocating parts of a large gas-engine for different values of the time t . The velocity gained between times t_1 and t_2 is $\int_{t_1}^{t_2} a dt$. The velocity is 0 when $t = 0$. Find the velocity (1) when $t = 0.087$ seconds, (2) when $t = 0.1333$ seconds.

t seconds	0	0.0167	0.0333	0.0500	0.0667	0.0833	0.1000	0.1167	0.1333
a ft. per sec. per sec.	453.2	429.5	362.1	261.9	143.8	24.1	-82.8	-167.5	-226.6

9. The shearing force across a beam at a point A is 300 lbs. w is the load per foot at a distance x feet from A . The shearing force at a distance x from A is obtained by subtracting $\int_0^x w/x$ from the shearing force at A . Find the shearing force (1) 6.5 ft. from A , (2) 3 ft. from A .

x	0	1	2	3	4.1	4.6	5.3	5.8	6.5
w	10	10	11.75	17	22.4	23.2	22	19.1	10.4

10. If s is the specific heat of a body at temperature θ° , the total heat given to unit mass of the body in raising its temperature from θ_1 to θ_2 is $\int_{\theta_1}^{\theta_2} s d\theta$. The following table gives the specific heat of water at temperature θ . Find the total heat required to raise the temperature of a gram of water from 0° C. to 20° C.

θ° C.	s .
0	1.00664
2	1.00543
4	1.00435
6	1.00331
8	1.00233
10	1.00149
12	1.00078
15	1.00000
16	0.99983
18	0.99959
20	0.99947

11. Find the total heat required to raise the temperature of a gram of water from 4° to 31° . The values of s up to 20° are given in example 10. Beyond 20° we have—

θ° C.	x .
22	0.99955
24	0.99983
25	1.00005
26	1.00031
28	1.00098
31	1.00241

192. Definite Integral of a Function.—Instead of having corresponding values of y and x given in a tabulated list, we may have y , expressed as a function of x . From this we may calculate a series of values of y and proceed as before.

In general, if $F(x)$ is any function of x which can be represented by a curve between the limits a and b of x , we can find the value of $\int_a^b F(x)dx$ by a graphic method.

EXAMPLE (1).—Find the value of $\int_2^3 x^3 dx$.

Calculate the values of x^3 for a number of values of x between 2 and 3.

x	2.0	2.2	2.4	2.6	2.8	3.0
x^3	8.0	10.65	13.82	17.58	21.95	27.0

From these values plot the curve $y = x^3$ from $x = 2$ to $x = 3$.

We get the curve AB.

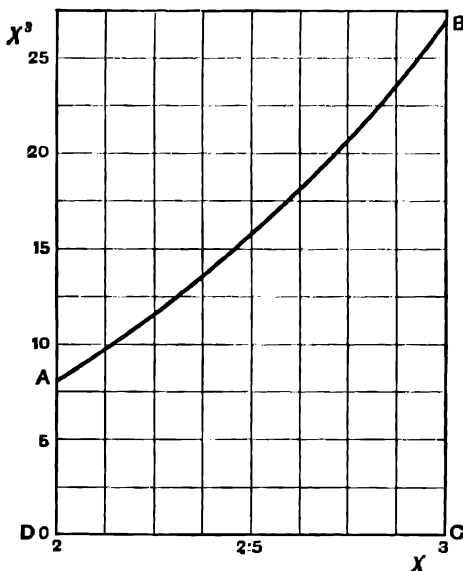

FIG. 100.

The value of $\int_2^3 x^3 dx$ is then given by the area **ABCD** enclosed by this curve, the ordinates at its extremities, and the axis of x . This area is found to be 16.24.

$$\therefore \int_2^3 x^3 dx = 16.24$$

EXAMPLE (2).—Find the value of $\int_0^{\frac{\pi}{2}} \sin^2 \theta d\theta$.

Calculate the values of $\sin^2 \theta$ for a number of values of θ between 0 and $\frac{\pi}{2}$, taking θ in radians.

θ degrees .	0	18	36	54	72	90
θ radians .	0	0.3142	0.6283	0.9425	1.2566	1.5708
$\sin \theta$. .	0	0.3090	0.5878	0.8090	0.9511	1.0
$\sin^2 \theta$. .	0	0.0955	0.345	0.654	0.904	1.0

Plotting $\sin^2 \theta$ and θ , we get the curve shown.

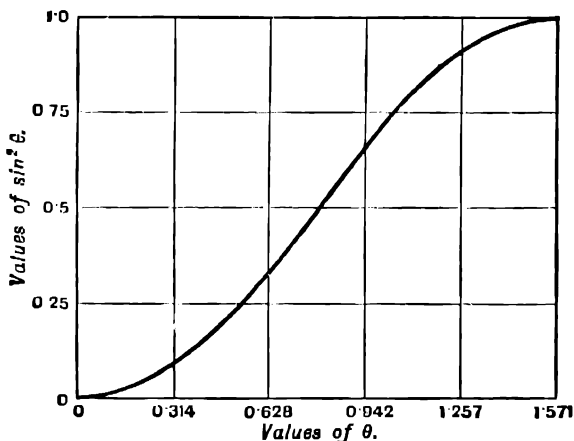

FIG. 101.

By Simpson's Rule the area between this curve and the axis of θ is found to be 0.785.

$$\therefore \int_0^{\frac{\pi}{2}} \sin^2 \theta d\theta = 0.785$$

Note that, although it is convenient to take θ in degrees when plotting the curve, we measure θ in radians when finding the area.

EXAMPLE (3).—In finding the perimeter of an ellipse of major axis 2 and eccentricity 0.5, we require to find the value of the expression $\int_0^{\frac{\pi}{2}} \sqrt{1 - 0.25 \sin^2 \phi} d\phi$.

To find the value of this integral by a graphic method.

Plot the curve $y = \sqrt{1 - 0.25 \sin^2 \phi}$ between the limits $\phi = 0$ and $\phi = \frac{\pi}{2} = 1.5708$.

Set down the work as follows :—

ϕ radians.	$\sin \phi$.	$\sin^2 \phi$.	$0.25 \sin^2 \phi$.	$1 - 0.25 \sin^2 \phi$.	$\sqrt{1 - 0.25 \sin^2 \phi}$.
0.0	0.0	0.0	0.0	1.0	1.0
0.5236	0.5	0.25	0.0625	0.9375	0.968
1.5708	1.0	1.0	0.25	0.75	0.866
1.0472	0.866	0.75	0.1875	0.8125	0.9014
0.7854	0.7071	0.5	0.125	0.875	0.9353
0.3491	0.342	0.11696	0.02924	0.97076	0.985
1.2566	0.951	0.9044	0.2261	0.7739	0.88
0.1745	0.1736	0.0302	0.00755	0.99245	0.996

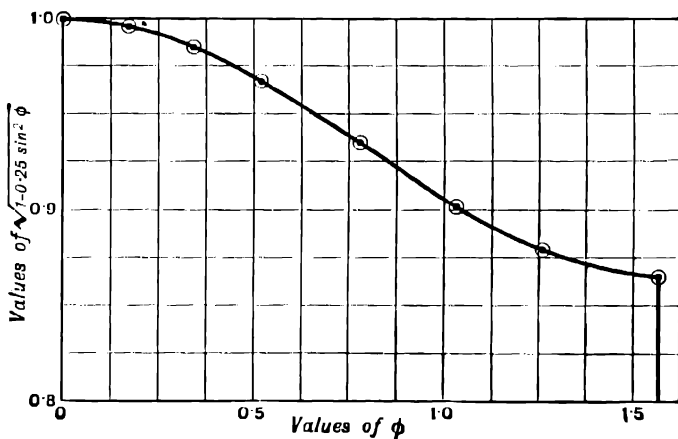

FIG. 102.

On plotting these values we get the curve shown.

The area enclosed by this curve, the line $y = 0$, and the ordinates for which $\phi = 0$ and $\phi = 1.5708 = \frac{\pi}{2}$ is found to be 1.47.

$$\therefore \int_0^{\frac{\pi}{2}} \sqrt{1 - 0.25 \sin^2 \phi} d\phi = 1.47$$

EXAMPLE (4).—A gas expands so as to follow the law $pv = C$. When the volume is 1 cub. ft. the pressure is 2116 lbs. per square foot. Find the work done as the gas expands to fill a volume of 3 cub. ft.

We know that the work done in expanding from volume v_1 to volume v_2 is $\int_{v_1}^{v_2} p \, dv$.

We have $p v = C$, and therefore $p = \frac{C}{v}$.

To find C we have, when $v = 1$, $p = 2116$.

$$\therefore C = 2116, \text{ and } p = \frac{2116}{v}$$

Calculating values of p , we get—

v	1	1.25	1.5	2	2.5	3
p	2116	1690	1411	1058	846	705

Plotting these values we get the curve shown.

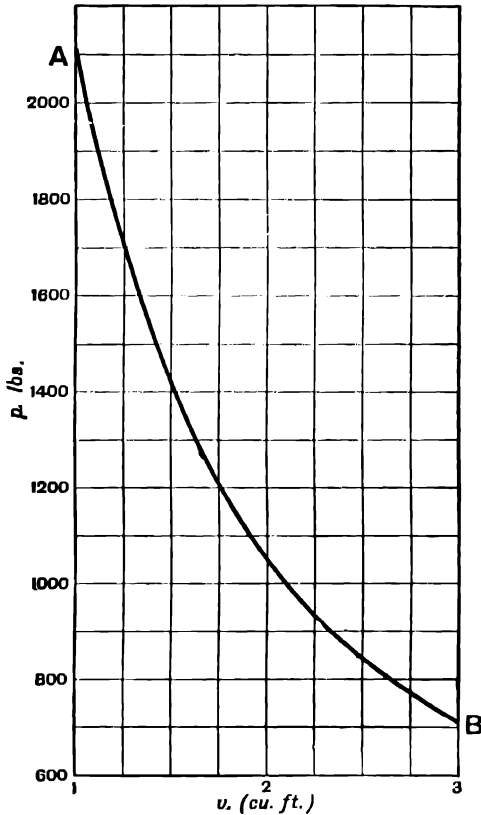

FIG. 103.

The area under this curve is found to be 2321.

$$\therefore \text{work done} = \int_1^3 p \, dv = 2321 \text{ ft.-lbs.}$$

EXAMPLES.—LXXV.

Find the value of the following integrals by a graphic method :—

- | | | |
|---|--|---|
| 1. $\int_1^3 x^4 dx.$ | 2. $\int_1^{10} \frac{dx}{x}.$ | 3. $\int_0^{\pi} \sin \theta \, d\theta.$ |
| 4. $\int_0^3 e^{1/2} dx.$ | 5. $\int_0^1 \frac{dx}{1+x^2}.$ | 6. $\int_0^2 \sqrt{4-x^2} dx.$ |
| 7. $\int_3^{10} \frac{252}{v} dv.$ | 8. $\int_0^3 x\sqrt{9-x^2} dx.$ | 9. $\int_0^1 x^{0.5}(1-x)^{0.5} dx.$ |
| 10. $\int_0^1 x^{1.5}(1-x)^{1.5} dx.$ | 11. $\int_0^{0.09} \frac{dx}{\sqrt{1-x^2}}.$ | |
| 12. $\int_0^{\pi} \sin^3 \theta d\theta.$ | 13. $\int_0^{0.8727} \sqrt{1-0.25 \sin^2 \phi} d\phi.$ | |

14. A quantity of steam expands so as to follow the law $pv^{0.9} = 8000$, where v is the volume at pressure p . Find the work done as the steam expands from volume 1 to volume 10.

15. A quantity of air expands so as to follow the law $pv^{1.41} = C$. $p = 21160$ when $v = 1$. Find the work done in expansion from volume 2 to volume 5.

16. In a paper by Lord Kelvin, on motion in an elastic solid, it was required to find the value of $\int_0^1 (p-1)r^2 dr$, when the following values were given :—

r	0.00	0.02	0.04	0.06	0.08	0.10	0.20	0.30	0.40	0.50	0.60	0.70	0.80	0.90	1.00
p	101.1	78.5	64.4	49.6	39.5	31.8	11.8	5.00	2.46	1.34	0.82	0.53	0.38	0.36	1.00

Find the value of this integral.

133. Variable Limit of Integration.

Consider the definite integral $\int_a^x y dx$, where the lower limit a is fixed and the upper limit x starts from the value a and gradually increases.

Let AB be the curve representing y as a function of x .

Let $OM = a$ and $ON =$ the upper limit x .

Then $\int_a^x y dx$, which we shall denote by I , is equal to the area $ABNM$, and, as the upper limit x increases, N starts at M and moves along Ox through the positions N, N', N'' , while B moves along the curve AB . At the same time the value of I continually increases in the case shown in the figure.

Thus for every value ON of x there is a definite value of I equal to the area $ABNM$, and I is a function of x . When N moves to N' an amount equal to $BB'N'N$ is added to I , and so on.

If at various points on Ox we erect ordinates to represent on some convenient scale the value of the area under the curve AB from AM to the

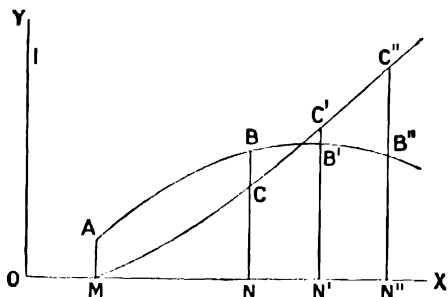

FIG. 104.

respective points CD , we obtain a curve representing the definite integral I as a function of x .

In the figure the curve $MCC'C''$ is drawn so that any ordinate $N'C'$ represents the area $AB'N'M$ between AM and $C'N'$ on some convenient scale.

This curve represents I , or $\int_a^x y dx$ as a function of x .

EXAMPLE (1).—Plot a curve representing $\int_2^x x^3 dx$ as a function of x from $x = 2$ to $x = 6$.

$$\text{Let } I = \int_2^x x^3 dx$$

We have already (example 1, p. 247) found the value of I when $x = 3$. We must now find the value of I for other values of x between 2 and 6, and plot a curve in which the ordinates shall represent the values of I , and the abscissae the corresponding values of x .

First draw the curve $y = x^3$ from $x = 2$ to $x = 6$. This is the curve AB (Fig. 105). To get the curve CD representing I , proceed as follows. Divide the area into any number of strips of equal width. In the figure we have taken 8 strips each of width 0.5 .

$$\text{When } x = 2, I = \int_2^2 x^3 dx = 0 \quad \therefore C \text{ is on the required curve}$$

$$\begin{aligned} \text{When } x = 2.5, I &= \int_2^{2.5} x^3 dx = \text{area ACFE} \\ &= CF \times (\text{ordinate of curve AE at point } x = 2.25) \\ &= 0.5 \times 11.4 = 5.7 \end{aligned}$$

Set off FG equal to 5.7 on the scale for I . Then G is a point on the required curve.

To get the value of I when $x = 3$, add the area of the next strip $EFHK$, which is $0.5 \times 20.8 = 10.4$. This gives the point L on the curve CD . Similarly, successive points on the curve CD are obtained by adding in succession the areas of the strips into which the area under the curve AB is divided.

Finally, the ordinate at **D** represents the whole area **ABMC**, which is equal to $\int_2^6 x^2 dx$.

The scales on which I and x are represented need not be the same. The student

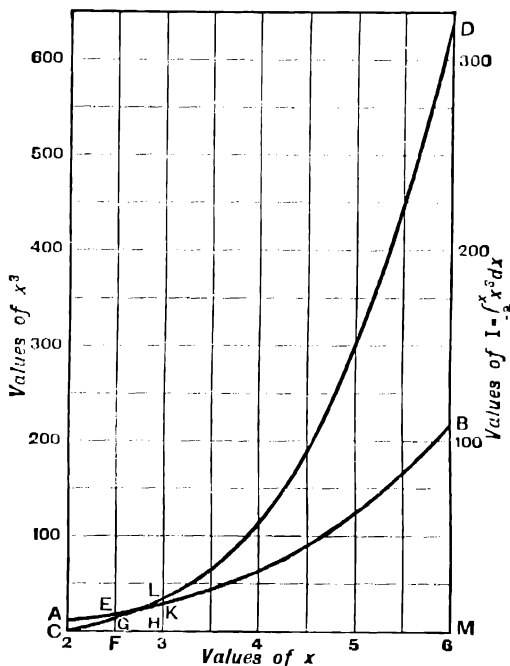

FIG. 105.

should form an estimate of the greatest value of I that will be required before choosing the scale on which I is to be represented.

The area of each strip is equal to its base multiplied by its mean height, and may be represented by that height if a suitable scale be chosen for I . Thus the addition of the areas of successive strips may be very rapidly performed with a pair of dividers, by marking off lengths equal to the mean heights of the successive strips.

In the above example the width of each strip is 0.5, and its area is therefore numerically equal to one-half its mean height. We choose the scale of I so that the mean height may represent the area, *i.e.* we take the scale for I equal to twice the scale for x^2 . Thus the curve **CD** may be rapidly constructed with dividers. The area of the first strip **AEFC** is 5.7, and 5.7 on the scale for I is equal to the ordinate 11.4 at the mid point of **CF** on the scale for x^2 , and the point **G** is obtained by marking off, on the ordinate **FE**, a length equal to the ordinate to **AB** at the mid point of **CF**. Similarly, **L** is obtained by adding to this length on the ordinate **HK** a length equal to the ordinate to **AB** at the mid point of **FH**, and so on.

EXAMPLE (2).—A car weighs 10 tons, and is drawn by the pull P lbs., varying in the following way, t being the time in seconds from starting.

P	1020	980	882	720	702	650	713	722	805
t	0	2	5	8	10	13	16	19	22

The retarding force of friction is constant and equal to 410 lbs. Plot P - 410 and the time t, and from this obtain a curve showing speed and time.
 (Board of Education Examination in Applied Mechanics, 1902.)

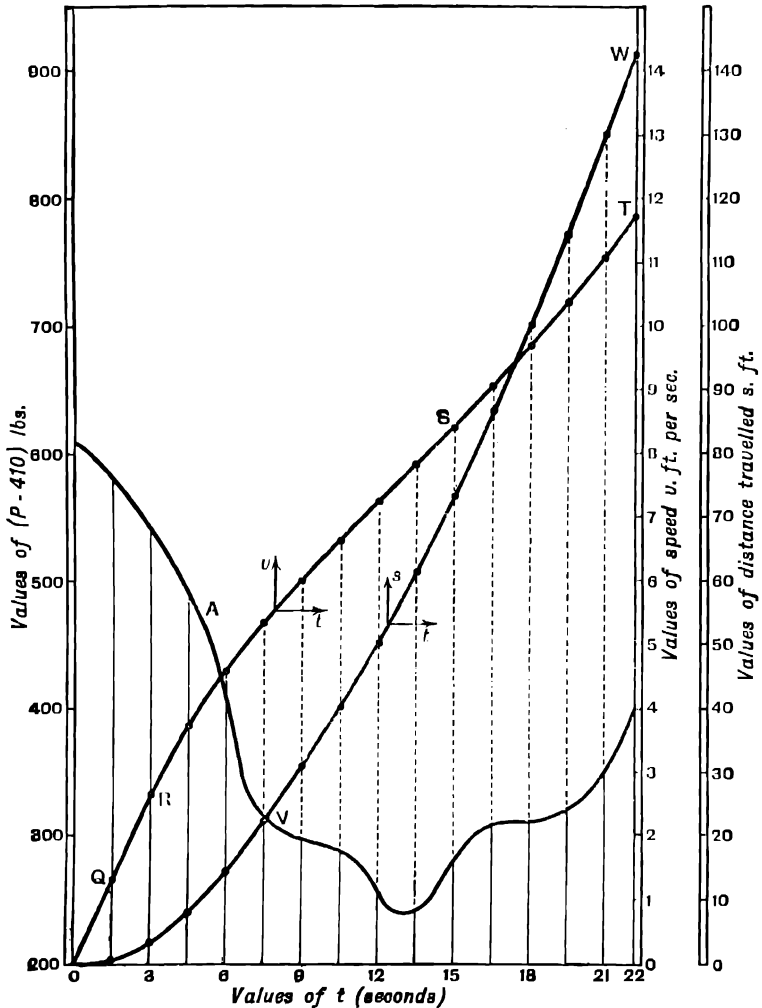

FIG. 106.

We have already seen (p. 243) that the momentum of the car when $t = 22$ seconds is $\int_0^{22} (P - 410)dt$, and its speed when $t = 22$ seconds is equal to its momentum divided by its mass $= \frac{32 \cdot 2}{22400} \int_0^{22} (P - 410)dt = 0\cdot001437 \int_0^{22} (P - 410)dt$ feet per second.

In the same way, its speed at any time t seconds from starting is

$$0\cdot001437 \int_0^t (P - 410)dt$$

and we shall first plot a curve showing the speed as a function of t .

The curve showing $P - 410$ and t has already been plotted (p. 244), and is here reproduced.

Divide the area under this curve into strips by ordinates drawn as in the figure. The width of the first strip is 1.5, and its mean height, reckoned from the axis $P - 410 = 0$, which is not shown in the figure, is 595.

$$\therefore \int_0^{1.5} (P - 410)dt = 1.5 \times 595 = 892.5$$

and the speed at the end of 1.5 seconds is $0\cdot001437 \times 892.5 = 1.29$ ft. per second.

Accordingly we plot the point **Q**, whose ordinate is 1.29, on a suitable scale to represent the speed when $t = 1.5$. Similarly the ordinate at **R** which represents the speed at the end of 3 seconds from rest is obtained by adding to the ordinate of **Q** a length equal to the area of the second strip multiplied by 0.001437.

Proceeding thus we obtain the curve **QRST**, which gives the speed at any time, the final speed being 11.7 ft. per second, as in example 2, p. 243.

EXAMPLES.—LXXVI.

1. Plot a curve showing the value of $\int_0^x x^2 dx$ for all values of x from $x = 0$ to $x = 5$.
2. Plot $\int_1^x (2x + 1)dx$ for all values of x from $x = 1$ to $x = 10$.
3. Plot $\int_1^x (1 + x^2)dx$ from $x = 1$ to $x = 10$. From your curve read off the value of the integral when $x = 4$.
4. Plot $\int_0^x (3x^2 + 2x - 4)dx$ from $x = 0$ to $x = 6$.
5. Plot $\int_0^\theta \sin \theta d\theta$ from $\theta = 0$ to $\theta = \frac{\pi}{2}$.
6. Plot $\int_{0.1}^x \frac{dx}{x}$, from $x = 0.1$ to $x = 3$.
7. Plot $\int_0^x \frac{dx}{\sqrt{1-x^2}}$ from $x = 0$ to $x = 0.9$.
8. Plot $\int_0^x \frac{dy}{dx}$, where $y = x^2 + 2x + 1$, from $x = 1$ to $x = 2$.
9. The following table gives the pull P at the drawbar of an electromotor at time t seconds from starting :—

P lbs. . .	1150	1450	1320	1350	1040	1300	1150	1370	1120	750
<i>t</i> seconds .	0	12.5	25	37.5	43	50	55	62.5	75	83

Deduct 300 lbs. for friction, air resistance, etc., which are taken as constant, and plot a curve to show the value of $P - 300$ for any value of t from 0 to 83. The train weighs 21 tons. Obtain a curve to show the speed at any time from $t = 0$ to $t = 83$ secs.

10. P is the resultant pressure on the piston of a bull engine when the weight has been raised to a height h feet. The work done in raising the weight to the height h is $\int_0^h P dh$ ft.-lbs. Plot a curve to show the work done in raising the weight to any height from 0 to 8 ft.

h feet	0	0.5	1	1.5	2	3	4	5	6	7	8
P lbs.	110	110	110	110	100	73	54	44	38	34	30

11. The following table gives the drawbar pull exerted by an electric locomotive at distance s from rest :—

P lbs.	930	1000	930	835	1000	1225	1325	1300	1230	1000	800	650
s feet	0	15	30	45	80	110	160	180	200	227	260	300

The work done in drawing the train from rest to a distance s is $\int_0^s P ds$. Plot a curve to show the work done for any value of s from 0 to 300 ft.

Examples 9 and 11 are adapted from a paper by P. V. MacMahon, in the *Electrician* for June, 1899, p. 227, where the student will find additional material for examples. The data refer to the City and S. London Railway.

12. A body weighing 1610 lbs. is lifted vertically by a rope, there being a damped spring balance to indicate the pulling force F lbs. of the rope. When the body had been lifted x feet from its position of rest, the pulling force was recorded automatically as follows :—

x	0	11	20	34	45	55	66	76
F	4010	3915	3763	3532	3366	3208	3100	3007

Draw a curve showing the probable value of the velocity v feet per second for all values of x up to 80.

NOTE.—The resultant upward force on the body is $F - 1610$ lbs. The work done

in increasing the kinetic energy of the body is equal to $\int_0^x (F - 1610)dx$. Since the body starts from rest this is also equal to the kinetic energy $\frac{1}{2}mv^2$, where m is the mass of the body = $\frac{1610}{32 \cdot 2}$. Thus the value of v can be obtained for any value of x .
(Board of Education Examination in Applied Mechanics.)

13. The following table gives the force F producing the acceleration of the reciprocating parts weighing 2080 lbs. of a 400 H.P. Crossley gas-engine at intervals of $\frac{1}{10}$ second.

t seconds	0	0'0167	0'0333	0'0500	0'0667	0'0833	0'1000
F lbs.	29270	27740	23390	16920	9287	1560	- 5349

t seconds	0'1167	0'1333	0'1500	0'1667	0'1833	0'2000	
F lbs.	- 10820	- 14640	- 16920	- 18010	- 18180	- 18580	

Construct a curve to show the velocity at any time from $t = 0$ to $t = 0.2$ second. Given, velocity = 0 when $t = 0$.

14. The following table gives the resultant turning moment M exerted on the crank of a 500 H.P. Crossley gas-engine for different values of the angle θ through which the crank turns. It can be shown that $\int_0^\theta M d\theta$ varies as the square of the angular velocity ω for any value of θ , so that an ordinate equal to this integral will represent ω^2 on a suitable scale.

Construct a curve to show how the angular velocity ω varies for different values of θ . The scale for ω need not be shown.

θ degrees	0	14	28	46	72	100	131	180	218	243	270	302	327	350	355	360
M ft.-lbs. per sq. in. of piston	-41	34	109	129	115	109	59	-41	-91	-107	-91	-41	31	-41	-43	-41

NOTE.—Since the scale of the resulting curve is not determined, θ may be taken in degrees.

Examples 13, 14 are adapted from a paper by Mr. Humphrey (*Proceedings Institute Mechanical Engineers*, Jan., 1901, p. 67), where a number of curves are given.

134. Construction of Curves from a given Law of Slope.

With the same notation as before (§ 133), let x increase by a small amount δx , so that N moves through a short distance NN' .

Then I is increased by the area $BB'N'N$, which is equal to NN' multiplied by a value ST of y between NB and $N'B'$.

$$i.e. \delta I = ST \times \delta x$$

$$\frac{\delta I}{\delta x} = ST$$

To find $\frac{dI}{dx}$ we must find the limiting value of $\frac{\delta I}{\delta x}$ as δx approaches the value 0.

In this case N' moves back to N and B' to B , and thus ST , which must

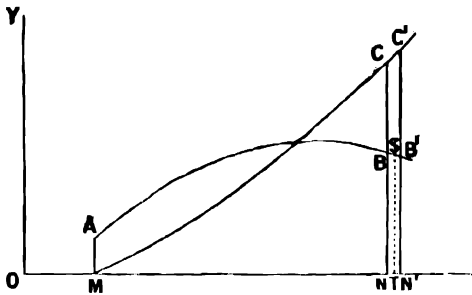

FIG. 107.

always lie between NB and $N'B'$, moves back to and ultimately coincides with NB .

$$\therefore \frac{dI}{dx} = NB = y \quad \dots \dots \dots (1)$$

Now the ordinate of the curve MCC' is equal to the value of I , and therefore $\frac{dI}{dx}$ measures the slope of the curve MCC' .

Thus equation (1) states that the slope of the curve MCC' is equal to the ordinate of the curve AB , and we have shown how to construct the curve MCC' when its law of slope is given by the ordinate of the curve AB .

For example, in example 1, p. 252, we showed how to draw the curve CD , representing $\int_2^x x^3 dx$, when its law of slope $\frac{dI}{dx} = x^3$ was given by the curve AB .

In example 2, p. 255, we showed how to draw a curve, representing $\int_0^t (P - 4t) dt$, when its slope $P - 4t$ at any point was given on a suitable scale by the curve A .

EXAMPLE (1).—The following table gives the value of the slope $\frac{dy}{dx}$ of a certain curve for different values of x :—

x	1.2	1.9	2.7	4	5.2	6
$\frac{dy}{dx}$	0.55	1.1	1.4	0.32	0.4	0.65

Construct the curve between $x = 1.2$ and $x = 6$, having given that $y = 2$ when $x = 1.2$.

There are evidently an Infinite number of curves having the given law of slope, for

if one be constructed it may be supposed moved in a direction parallel to the axis of y without changing its shape, and thus we may obtain as many more curves as we please, all having the same law of slope. We require to choose that particular curve in which $y = 2$, when $x = 1.2$.

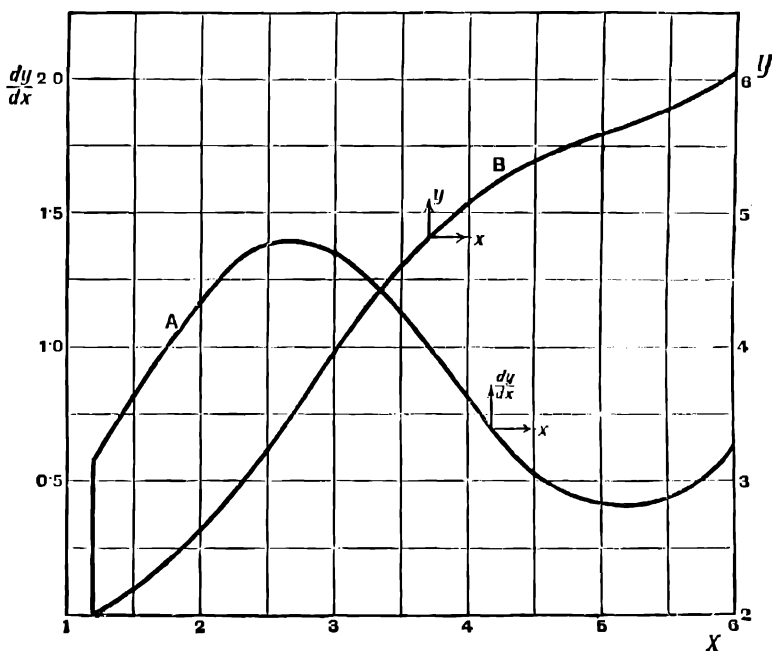

FIG. 108.

First construct the curve **A**, Fig. 108, whose ordinates represent values of $\frac{dy}{dx}$ given in the table.

From this obtain, by the method of p. 251, the curve **B**, whose ordinate for any value of x is equal to the area under the curve **A** from $x = 1.2$ to that value of x .

This gives the value of $\int_{1.2}^x \frac{dy}{dx} dx$ which, as has been shown above, is equal to the value of y in the required curve if measured from a suitable point. We then adjust the scale for y so that $y = 2$ when $x = 1.2$, and **B** is the required curve.

EXAMPLE (2).—In example 2, p. 254, we obtained a curve giving the value of the speed v of a car at any time between 0 and 22 seconds from starting. To construct a curve to show the distance s moved by the car from rest at any time between 0 and 22 seconds.

We know that $v = \frac{ds}{dt}$ and therefore the velocity curve already obtained represents the slope at any value of t of the required curve representing s .

We therefore obtain the s curve from the v curve by plotting the values of $\int_0^t v dt$ in the same way as the velocity curve was obtained from the curve **A** representing the force, and therefore also the acceleration. The initial value of s is evidently zero.

The resulting curve **VW** is given in Fig. 106.

EXAMPLE.—LXXVII.

1. The following table gives the slope of a certain curve for various values of x . It is known that $y = 3.5$ when $x = 2$. Construct the curve between $x = 2$ and $x = 8.5$. From your curve read off the values of y when $x = 5$ and when $x = 8$.

Value of x	2	2.3	2.6	3	3.6	4.3	5
Slope of curve	0	0.48	0.78	1.025	1.15	0.97	0.44
Value of x	5.44	5.90	6.3	6.9	7.5	8.1	8.5
Slope of curve	0	-0.47	-0.80	-0.93	-0.8	-0.4	0

2. Let $y = x^2$. Plot the curve $y = x^2$ on a large scale from $x = 0$ to $x = 3$. Plot also $y = 2x$ from $x = 0$ to $x = 3$. Then, since $\frac{d}{dx}x^2 = 2x$, the ordinate of the second curve measures the slope of the first for any value of x . Measure the area between the second curve and the axis of x from $x = 0$ to $x = 3$, and verify that it is equal to the ordinate of the first curve at $x = 3$.

3. A curve is such that its slope at any point is equal to twice the abscissa at that point. Construct the curve. It is given that the curve passes through the point (1, 2).

4. The slope of a curve at any point is equal to $2x - 1$, where x is the abscissa of that point. Construct the curve, having given that $y = 8$ when $x = 3$.

5. Construct a curve in which the relation between y and x is such that the equation

$$2\frac{dy}{dx} + 3x - 4 = 0$$

is satisfied at every point of the curve. It is given that $y = 0$ when $x = 0$.

6. The following table gives the speed v in feet per second of a train in the City and South London Electric Railway at time t seconds from starting. Plot a curve to show the speed at any instant from $t = 0$ to $t = 174$ seconds.

If s is the distance moved in t seconds we know that $v = \frac{ds}{dt}$, and therefore the ordinate of the speed curve gives the slope of the distance curve for any value of t . Hence construct a curve to show the distance s travelled at any time t from $t = 0$ to $t = 174$ seconds.

t seconds	0	25	30	40	50	70	75
v ft. per sec.	0	12.45	14.65	18.31	19.35	20.96	20.22
t seconds	90	105	125	145	160	174	
v ft. per sec.	18.90	17.87	19.42	20.51	16.1	0	

7. From the data given in example 7, p. 245, construct a curve to show the distance travelled by the car from rest at $t = 0$ to any time from 0 to 30 secs. From your curve read off the distance travelled in 16.5 secs.

8. In the following table v is the velocity of the projectile in the bore of a gun at time t seconds from the beginning of the explosion :—

t seconds .	0'00490	0'00598	0'00695	0'00785	0'00871	0'00953	0'01032	0'01109	0'01184
v ft. per sec.	869	987	1074	1142	1195	1242	1277	1309	1335

Plot a curve to show the distance s described by the shot for all values of t from 0'00490 to 0'01184, having given that $s = 2$ ft. when $t = 0'00490$.

9. a is the acceleration of an electric tramcar at time t from starting.

a ft. per sec. per sec.	2'4	3'25	3'52	3'45	3'21	2'63	1'70	1'12	0'64	0'27	0
t seconds	0	1	2	3	4	5	6	7	8	9	10

Find its velocity (a) after 3 secs. from starting, (b) after 7 secs. from starting, (c) after 10 secs. from starting. Construct a curve to show the velocity at any time from $t = 0$ to $t = 10$ secs.

10. From the curve of velocities obtained in example 9, find the distance travelled by the car (a) in 3 secs., (b) in 7 secs., (c) in 10 secs. from starting. Construct a curve to show the distance travelled from starting at any time from $t = 0$ to $t = 10$ secs.

11. P is the pull in pounds exerted by an electric locomotive at time t seconds from starting. Take the tractive resistance as constant and equal to 881 lbs. Then the acceleration is proportional to $P - 881$, and it is found that the acceleration is 1'46 ft. per second per second when $P = 5750$ lbs. Plot curves to show (a) the acceleration, (b) the velocity, (c) the distance passed over, at any time from 0 to 130 seconds.

P	7125	6100	5690	5625	5650	5725	5750	881 constant	0
t	0	2	5	8	10	14	16	16 to 114	114 to 130

(Adapted from P. V. MacMahon, *Electrician*, June 16, 1899.)

12. P is the pressure on the base of the projectile of a gun at time t seconds from the beginning of the explosion.

Time of travel, seconds.	P tons.
0'00000	2000'0
0'00143	2221'3
0'00273	3320'5
0'00360	2060'6
0'00490	1394'1
0'00598	1095'0
0'00695	908'8
0'00785	746'4
0'00871	668'3
0'00953	592'8
0'01032	499'4
0'01109	421'9
0'01184	355'6

The weight of the projectile is 78 lbs.

Assuming that the sides of bore and the air in front exert no retarding force on the projectile, the acceleration is obtained by dividing P in lbs. by the mass $\frac{78}{32 \cdot 2}$.

Plot curves to show the acceleration, velocity and distance travelled at any instant throughout the period considered.

It will be found that the given values do not lie exactly on a regular curve when plotted. A more reliable result will be obtained by drawing a smooth curve, lying as evenly as possible among the plotted points than by making the curve pass exactly through the points plotted from the given data.

13. The following table gives the acceleration a of the reciprocating parts of a 500 H.P. Crossley gas-engine for different values of the time t . Construct a curve to show the velocity at any time from $t = 0$ to $t = 0 \cdot 48$, given that the velocity is zero when $t = 6$.

t seconds	0	0'02	0'04	0'06	0'08	0'10	0'12
a ft. per sec. per sec.	258'7	245'4	207'7	151'4	84'75	16'78	-44'60
t seconds	0'48	0'46	0'44	0'42	0'40	0'38	0'36

t seconds	0'14	0'16	0'18	0'20	0'22	0'24
a ft. per sec. per sec.	-94'03	-129'3	-151'4	-163'1	-168'1	-169'5
t seconds	0'34	0'32	0'30	0'28	0'26	0'24

From $t = 0 \cdot 24$ to $t = 0 \cdot 48$, a passes back through the same values as from $t = 0$ to $t = 0 \cdot 24$.

14. I_1 is the magnetic induction through a coil of an induction motor at time t . The values of $\frac{dI_1}{dt}$ are observed and given in the following table. Construct a curve to show the induction I_1 for all values of t throughout the period considered. Take $I_1 = 0$ when $t = 0$.

t secs.	0	0'05	0'10	0'15	0'20	0'25	0'30	0'35	0'40	0'45	0'50
$\frac{dI_1}{dt}$ volts	1'286	1'233	0'949	0'774	0'556	0'108	0'026	-0'429	-0'864	-1'049	-1'286

15. The following table gives particulars of another test of the same motor as in the last example. Construct a curve to show the induction I_1 for all values of t as before, taking $I_1 = 0$ when $t = 0$.

<i>t</i> secs.	0	0'05	0'10	0'15	0'20	0'25	0'30	0'35	0'40	0'45	0'50
$\frac{dI_1}{dt}$ volts	2'44	2'34	1'88	1'51	1'05	0'25	-0'59	-1'28	-1'63	-2'01	-2'44

16. A horizontal bar, 12 ins. long, is fixed at one end, and is loaded in such a way that the weight *w* per unit length at various points is given by the following table. *x* is the distance from the free end.

<i>x</i> inches . .	0	4	8	10	11
<i>w</i> lbs. per in.	4	5'2	8'3	12'2	20

Plot a curve to show the value of *w* at any point. Note that the load varies continuously. The expression "weight per unit length" does not imply that the load is uniform for a unit length of the bar at any place.

It is known that $w = \frac{dS}{dx}$, where *S* is the shearing force at distance *x* from the free end, also *S* = 0 at the free end.

Construct a curve to show the value of *S* at any point. What is the shearing force at the fixed end?

17. In the last example, if *M* is the bending moment, then $S = \frac{dM}{dx}$ at distance *x* from the free end. Construct a curve to show the bending moment at any point. *M* = 0 at the free end.

18. A beam 10 ft. long is loaded in the manner given in the following table. *w* and *x* have the same meanings as in examples 16, 17. Plot curves to show (1) the load per unit length, (2) the shearing force, (3) the bending moment at any point. What is the shearing force at the fixed end?

<i>x</i>	0	1	2	3	4	5	6	7	8	9	10
<i>w</i>	2	2'5	3'7	5'5	7'7	9'7	11'2	12'2	11'8	10'2	7'2

19. A horizontal bar 10 ins. long is fixed at one end. The other end carries a weight of 1000 lbs. The bar is also uniformly loaded with 200 lbs. per inch throughout its length. Plot a curve to show the shearing force at any point.

Note that *S* = 1000 when *x* = 0. What is the shearing force at the fixed end?

20. Plot a curve to show the bending moment at any point of the bar. *M* = 0 at *x* = 0. What is the bending moment at the fixed end?

21. Let *y* inches be the downward displacement of a point on the bar at a distance *x* inches from the free end. Then it is known that at any point the slope of the bar

$$= \frac{dy}{dx} = \int_0^x \frac{M}{EI} dx + C$$

where *M* is the bending moment, *E* and *I* are constants depending on the material and shape of the bar, and *C* is the slope of the beam where *x* = 0.

In this case, for a wrought-iron bar of rectangular section 3 ins. wide by 4 ins. deep, *E* = 25 × 10⁶, *I* = 16, and $\frac{dy}{dx}$ = 0 at the fixed end where *x* = 10.

Construct a curve having as its ordinate the slope of the bar at any point.

NOTE.—It is not necessary to know C . Construct the curve as though C were zero, and afterwards move the scale for $\frac{dy}{dx}$ so that the slope is shown as 0 at the fixed end where $x = 10$.

22. Construct a curve to show the displacement y of each point in the bar. The curve obtained in example 21 gives the law of slope of the required curve, and the required curve can therefore be constructed.

NOTE.—The displacement is evidently 0 at the fixed end, and the scale for y must therefore be moved so as to give this value. What is the displacement at the free end?

CHAPTER XVIII

DEFINITE INTEGRALS

135. Connection between Definite and Indefinite Integrals.

We have now shown that if I is the definite integral $\int_a^x y dx$

$$\text{then } \frac{dI}{dx} = y$$

But the indefinite integral $\int y dx$ has been defined as that function of x whose differential coefficient is equal to y .

\therefore the definite integral $\int_a^x y dx$, as defined in the last chapter, is identical with the indefinite integral $\int y dx$ as defined in Chapter XVI.

It is to be remembered, however, that the indefinite integral may have an added arbitrary constant.

The exact connection between these two ways of defining an integral will be made clearer by the following examples:—

EXAMPLE.—*Suppose it is given that, for a certain curve between $x = a$ and $x = b$, $\frac{dy}{dx} = 4x^2 - 2x$, and that $y = 0$ when $x = a$.*

To find the curve we may proceed in two ways.

I. We may plot the curve **AB**, whose ordinate is equal to $4x^2 - 2x$ for every value of x between a and b . This gives the law of slope of the required curve, which may now be obtained by plotting areas, as in the examples of the last chapter.

The ordinate y of the curve so obtained is equal to $\int_a^x \frac{dy}{dx} dx = \int_a^x (4x^2 - 2x) dx$,

and the final ordinate at $x = b$ is equal to $\int_a^b (4x^2 - 2x) dx$.

In the figure we have taken $a = 2$, $b = 8$, and **CD** is the curve obtained by this method.

II. But when $\frac{dy}{dx}$ is given by the expression $4x^2 - 2x$, y may be obtained from this by indefinite integration, as in Chapter XVI.

\therefore for the required curve

$$y = \int \frac{dy}{dx} dx = \int (4x^2 - 2x) dx = \frac{4}{3}x^3 - x^2 + C$$

where C is some constant.

We must choose C so that $y = 0$ when $x = a$.

Substituting, we have $0 = \frac{4}{3}a^3 - a^2 + C$

$$\therefore C = -\left(\frac{4}{3}a^3 - a^2\right)$$

for any value of x

$$y = \frac{4}{3}x^3 - x^2 - \left(\frac{4}{3}a^3 - a^2\right)$$

In particular when $x = b$

$$y = \left(\frac{4}{3}b^3 - b^2\right) - \left(\frac{4}{3}a^3 - a^2\right)$$

We have thus obtained an expression for the ordinate of the required curve for any value of x between $x = a$ and $x = b$, and the curve may be plotted directly from this expression. We find by substitution that in the case taken above, where $a = 2$, $b = 8$, the values of y obtained from this equation are equal to the corresponding ordinates of the curve **CD** in the figure ;

e.g. taking $x = 5$, $y = \left(\frac{4}{3}5^3 - 5^2\right) - \left(\frac{4}{3}2^3 - 2^2\right) = 135.7$

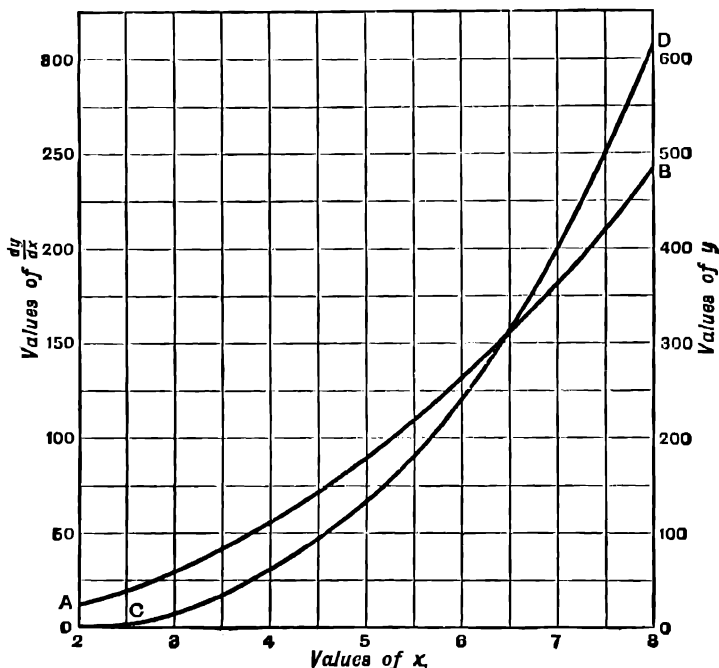

FIG. 109.

Thus we have found two different expressions for the ordinate of **CD**—one a definite integral, defined as in the last chapter, and the other an indefinite integral.

∴ equating these two expressions, we get

$$\int_a^x (4x^2 - 2x)dx = \frac{4}{3}x^3 - x^2 - \left(\frac{4}{3}a^3 - a^2\right)$$

In the special case where $x = b$, we get

$$\int_a^b (4x^2 - 2x)dx = \left(\frac{4}{3}b^3 - b^2\right) - \left(\frac{4}{3}a^3 - a^2\right)$$

= {value of indefinite integral $\left(\frac{4}{3}x^3 - x^2\right)$ when x is put equal to b after integration}
 - {value of indefinite integral when x is put equal to a after integration}.

196. Evaluation of a Definite Integral.

The same reasoning evidently holds good when $\frac{dy}{dx}$ is given equal to any function $F(x)$ of x of which the indefinite integral is known.

If $f(x)$ is the indefinite integral of $F(x)$, we have in general

$$\int_a^b F(x) dx = f(b) - f(a)$$

The right-hand side of this equation is written $[f(x)]_a^b$

This gives a method of calculating the value of the definite integral of any function when the indefinite integral is known.

To calculate the value of $\int_a^b y dx$.

First find the indefinite integral $\int y dx$. Find the value of this when x is equal to the upper limit b , and from the result subtract its value when x is equal to the lower limit a .

EXAMPLE (1).—

$$\int_2^3 x^3 dx = \left[\frac{x^4}{4} \right]_2^3 = \frac{3^4}{4} - \frac{2^4}{4} = 16.25$$

The value of this integral as found by the graphic method, p. 247, was 16.24.

EXAMPLE (2).—

$$\int_3^5 e^{0.2x} dx = \left[\frac{1}{0.2} e^{0.2x} \right]_3^5 = \frac{1}{2}(e^{1.0} - e^{0.6}) = 10.810$$

EXAMPLE (3).—Find the area between the curve $y = \sin x$ and the axis of x from $x = 0$ to $x = 1.5708$ radian = 90° . Also find the mean value of $\sin x$ between 0 and one right angle.

We have

$$\begin{aligned} \text{area} &= \int_0^{\frac{\pi}{2}} \sin x dx = \left[-\cos x \right]_0^{\frac{\pi}{2}} \\ &= \left(-\cos \frac{\pi}{2} \right) - (-\cos 0) = 0 + 1 = 1 \end{aligned}$$

The curve $y = \sin x$ is shown in Fig. 58.

The student should verify the above result, that the area between 0 and $\frac{\pi}{2}$ is 1, by actual measurement.

The mean value of $\sin x$ is the height of a rectangle on the same base, having an area equal to that between the portion of the curve considered and the axis of x .

If h is the mean value, we have

$$\begin{aligned} h \times 1.5708 &= \text{area} = 1 \\ \therefore h &= 0.637 \end{aligned}$$

EXAMPLE (4).—To find $\int_1^3 p dv$ having given that $pv = 2116$.

$$\begin{aligned} \int_1^3 p dv &= \int_1^3 \frac{2116}{v} dv = \left[2116 \log_e v \right]_1^3 \\ &= 2116 (\log_e 3 - \log_e 1) \\ &= 2116 \times 2.3026 \times 0.4771 = 2321 \end{aligned}$$

On page 251 we obtained the value 2321 by the graphic method.

EXAMPLE (5).—

$$\begin{aligned}\int_0^{\pi} \sin^2 \theta d\theta &= \frac{1}{2} \int_0^{\pi} (1 - \cos 2\theta) d\theta \\ &= \frac{1}{2} \left[\theta - \frac{1}{2} \sin 2\theta \right]_0^{\pi} \\ &= \frac{\pi}{4} - \frac{1}{2} \sin \pi = \frac{\pi}{4} = 0.7854\end{aligned}$$

The value of this integral found by the graphic method was 0.785, p. 248.

EXAMPLE (6).—Calculate the area enclosed by the curve $y = ax^n$, the ordinate at $x = b$ and the portion of the axis of x between the origin and the point $x = b$.

$$\begin{aligned}\text{Area} &= \int_0^b y dx = \int_0^b ax^n dx \\ &= \left[\frac{ax^{n+1}}{n+1} \right]_0^b = \frac{ab^{n+1}}{n+1}\end{aligned}$$

EXAMPLES.—LXXVIII.

Evaluate the following definite integrals :—

- | | | | |
|---|--|---|------------------------------------|
| 1. $\int_0^4 x^2 dx.$ | 2. $\int_1^5 x^3 dx.$ | 3. $\int_4^1 x dx.$ | 4. $\int_2^5 dx.$ |
| 5. $\int_5^2 dx.$ | 6. $\int_0^4 \sqrt{x} dx.$ | 7. $\int_3^5 2\sqrt{x} dx.$ | 8. $\int_2^3 (x^3 - 2x^2 + 3) dx.$ |
| 9. $\int_1^9 \frac{dx}{x^3}.$ | 10. $\int_2^8 \frac{dx}{x^2}.$ | 11. $\int_2^4 x^{17} dx.$ | 12. $\int_9^{10} x^{2.1} dx.$ |
| 13. $\int_{2.5}^{4.6} x^{0.92} dx.$ | 14. $\int_{2.3}^{0.5} x^{-1.37} dx.$ | 15. $\int_0^1 e^x dx.$ | |
| 16. $\int_1^2 e^x dx.$ | 17. $\int_{-1.2}^{-0.3} e^x dx.$ | 18. $\int_0^{\frac{1}{2}} e^{2x} dx.$ | |
| 19. $\int_0^1 e^{2x} dx.$ | 20. $\int_0^3 e^{\frac{1}{2}x} dx.$ | 21. $\int_1^2 e^{\frac{1}{2}x} dx.$ | |
| 22. $\int_0^4 e^{\frac{1}{2}x} dx.$ | 23. $\int_0^1 e^{\frac{1}{2}x} dx.$ | 24. $\int_0^1 \frac{dx}{e^{2x}}.$ | 25. $\int_0^{-1} e^{-2x} dx.$ |
| 26. $\int_0^{-1} e^{2x} dx.$ | 27. $\int_1^2 e^{0.82x} dx.$ | 28. $\int_1^3 \frac{3 dx}{e^{1.2x}}.$ | |
| 29. $\int_5^{10} \frac{5 dx}{e^{0.5x}}.$ | 30. $\int_0^{2.3562} \sin x dx.$ | 31. $\int_{1.5708}^{2.0044} \cos x dx.$ | |
| 32. $\int_{0.6109}^{1.4187} \sin x dx.$ | 33. $\int_{2.1817}^{4.7124} \cos x dx.$ | 34. $\int_0^{0.0286} \cos x dx.$ | |
| 35. $\int_0^{0.7854} \sin x dx.$ | 36. $\int_0^{\frac{\pi}{6}} \cos 3x dx.$ | 37. $\int_{\frac{\pi}{2}}^{\pi} \cos \frac{1}{2} x dx.$ | |
| 38. $\int_0^{\frac{\pi}{2}} \sin \frac{1}{2} x dx.$ | 39. $\int_0^{\pi} \cos 3x dx.$ | 40. $\int_0^{\frac{\pi}{2}} \sin (2x - 1) dx.$ | |

41. $\int_0^{\pi} 2 \sin(2x + 1) dx$. 42. $\int_0^{\pi} 2 \sin(1 - 4x) dx$. 43. $\int_0^{\pi} \sin 2\theta / \theta$.

44. $\int_{0.9142}^{0.9236} \sin(0.5\theta + 0.1745) d\theta$. 45. $\int_{0.1020}^{1.0309} \cos\left(1.3614 - \frac{t}{11}\right) dt$.

46. $\int_0^f \sin(2\pi ft + g) dt$. 47. $\int_0^{\frac{2\pi}{q}} \sin(qt - g) dt$.

48. $\int_1^8 \frac{10}{x} dx$. 49. $\int_1^8 \frac{100}{v} dv$. 50. $\int_2^3 \frac{150}{v} dv$.

51. $\int_2^3 \frac{dx}{x-1}$. 52. $\int_2^4 \frac{dx}{2x+1}$. 53. $\int_{-1}^0 (1-x)^{-4} dx$.

54. $\int_{-3}^{-4} \frac{dx}{1-x}$. 55. $\int_0^8 \frac{dx}{2x+1}$. 56. $\int_1^3 \frac{dx}{x+2}$.

57. $\int_1^3 v^{-1.43} dv$. 58. $\int_2^4 \frac{1000}{v^{1.414}} dv$.

59. Plot the straight line $y = \frac{1}{2}x + 1$ from $x = 0$ to $x = 4$. Verify by integration that the area of the figure formed by this straight line, the axes of x and y , and the ordinate at $x = 4$, is equal to the length of the base multiplied by the arithmetic mean of the lengths of the two parallel sides.

60. Find the area enclosed by the curve $y = 3x^3$, the axis of x , and the ordinate at $x = 5$. What is the mean value of y ?

61. Find the area enclosed by the curve $y = 2\sqrt{x}$ from $x = 0$ to $x = 1$, the axis of x , and the ordinate at $x = 1$. Verify by plotting and approximate measurement of the area.

62. Find the area between the curve $y = 5x - 4 - x^2$ and the axis of x from $x = 1$ to $x = 4$. Plot on a large scale, and verify by measurement.

63. Find the area between the curve $y = x^2 - 3x + 2$ and the axis of x from $x = 1$ to $x = 2$. Verify by plotting and measurement. Note the geometrical meaning of a negative value of the definite integral.

64. Find the area between the curve $y = 8x - x^4$ from $x = 0$ to $x = 2$, and the axis of x . Verify by plotting and measurement.

65. Find the area between the curve $y = \sin 2x$ and the axis of x from $x = 0$ to $x = \frac{\pi}{2}$.

66. We know that $\int_1^x \frac{1}{x} dx = \log_e x$. This gives a graphic method of calculating logarithms. Plot on a large scale the curve $y = \frac{1}{x}$, and from this construct by the graphic method the curve $y = \int_1^x \frac{1}{x} dx$. Verify by trial at various points that the ordinate of this curve is equal to $\log_e x = 2.303 \log_{10} x$.

67. Find the area between the curve $y = 2e^{3x}$ and the axis of x from $x = 0$ to $x = 2$.

68. Find the area between the curve $y = \frac{1}{x^2}$ and the axis of x from $x = 1$ to $x = 2$.

69. Find the area between the curve $y = \sin 4x$ and the axis of x from $x = 0$ to $x = 0.5236$ radians.

70. A quantity of gas expands so as to satisfy the law $pv = C$. Find the work done in expansion from $v = 1$ cub. ft. to $v = 10$ cub. ft. Given $p = 700$ lbs. per square foot when $v = 1$ cub. ft.

71. A quantity of steam expands so as to satisfy the law $pv^{1.13} = C$. Find the work done in expansion from $v = 3$ to $v = 10$. Given $P = 8000$ lbs. per square foot when $v = 1$ cub. ft.

72. Find the work done in the expansion of a quantity of steam from 2 cub. ft. at 4000 lbs. per square foot pressure to 8 cub. ft. The steam expands so as to satisfy the law $pv^{0.9} = C$.

73. A point starts from rest and moves along a straight line so that its velocity v feet per second is always numerically equal to one-third of the time in seconds which it has taken since starting. How far will it move in 4 secs. from rest?

74. A body of mass 10 units moves in a straight line so that the force acting on it at time t is

$$F = -3t^2 + 2t + 1$$

The acceleration is obtained by dividing the force by the mass. Find an expression for its velocity v at any time, having given that $v = 0$ when $t = 0$. Calculate the velocity when $t = 0.5$ and when $t = 1$.

75. Plot a curve to show the acceleration of the body in example 74 at any time from $t = 0$ to $t = 1$, and from this obtain by the graphic method the curve showing the velocity at any time. Compare with the calculated velocities for $t = 0.5$ and $t = 1$, and estimate the percentage error of your results obtained by the graphic method.

76. The shearing force S at any distance x from the free end of the bar in example 19, p. 263, is given by the formula

$$S = 200x + 1000$$

Obtain an expression for the bending moment in terms of x , and apply it to calculate the bending moment at the fixed end. Compare with the result obtained by the graphic method.

77. Obtain an expression for the slope of the bar in example 21, p. 263, at any point.

78. From the expression for $\frac{dy}{dx}$ obtained in the last example, find an expression for the displacement y at any point of the beam. Given $y = 0$ when $x = 10$. Calculate the value of y when $x = 0$, and compare with the results obtained by the graphic method.

79.—If $\phi_x = \log_e \frac{t}{273.7} + \frac{797}{t} - 0.695$, find formulæ for

$$\int_{t_1}^{t_2} t \frac{d\phi}{dt} dt \text{ and } \int_{t_1}^{t_2} (t - t_3) \frac{d\phi}{dt} dt.$$

137. Simpson's Rule.—We may now prove Simpson's rule for finding an area.

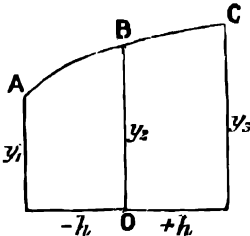

FIG. 110.

Let y_1, y_2, y_3 be three successive equidistant ordinates drawn to a curve and meeting it in A, B, and C. Let h be the distance between two successive ordinates.

Take the foot of the middle ordinate as origin, and assume, as on p. 140, that the portion ABC of the curve can be represented with sufficient accuracy by the equation

$$y = a + bx + cx^2$$

where $a, b,$ and c are constants to be determined.

To find the constants we have the condition that the curve passes through the three known points A, B, and C.

At A, $x = -h, y = y_1,$

$$\therefore \text{substituting, } y_1 = a - bh + ch^2 \quad \dots \quad (1)$$

At B, $x = 0, y = y_2,$

$$\therefore y_2 = a \quad \dots \quad (2)$$

At C, $x = h, y = y_3,$

$$\therefore y_3 = a + bh + ch^2 \quad \dots \quad (3)$$

Adding (1) and (3) we get

$$y_1 + y_3 = 2a + 2ch^2 = 2y_2 + 2ch^2$$

$$\therefore ch^2 = \frac{y_1 + y_3}{2} - y_2$$

Now the area enclosed by the curve **ABC**, the ordinates y_1 and y_3 , and the axis of x is

$$\int_{-h}^{+h} y dx = \int_{-h}^{+h} (a + bx + cx^2) dx$$

$$= 2ah + \frac{2}{3}ch^3$$

$$= \frac{h}{3} \{6y_2 + y_1 + y_3 - 2y_2\}$$

$$= \frac{h}{3} (y_1 + y_3 + 4y_2) \dots \dots \dots (4)$$

This is Simpson's rule for the case when there are 3 ordinates.

We get the form of Simpson's rule for any odd number of ordinates by making use of the result (4) to find the area between the 1st and 3rd ordinates, the 3rd and 5th, the 5th and 7th, and so on, and then adding the results.

For example, if there are 11 ordinates, the result (4) gives

$$\text{Area} = \frac{h}{3} \{y_1 + 4y_2 + y_3 + y_3 + 4y_4 + y_5 + y_5 + 4y_6 + y_7 + y_7 + 4y_8 + y_9 + y_9 + 4y_{10} + y_{11}\}$$

$$= \frac{h}{3} \{y_1 + y_{11} + 2(y_3 + y_5 + y_7 + y_9) + 4(y_2 + y_4 + y_6 + y_8 + y_{10})\}$$

In the same way Simpson's rule evidently follows for any odd number of ordinates.

Since we take the spaces between the ordinates two at a time in obtaining this rule, it is evident that it does not apply unless there is an even number of spaces, and therefore an odd number of ordinates.

In finding the area of a figure, such as the section of a ship (Fig. 80), we may increase the accuracy of our result by inserting intermediate ordinates where the curve is steepest. We may, for example, divide the area to be considered, in the first instance, into six spaces by seven equidistant ordinates, and then insert intermediate ordinates in the middle of the spaces at the two ends, as in the values given in the example, p. 165. We must substitute $\frac{h}{2}$ for h in the corresponding parts of the expression for the area.

We get

$$\text{Area} = \frac{h}{3} \{ \frac{1}{2}y_1 + 2y_2 + \frac{1}{2}y_3 + y_3 + 4y_4 + y_5 + y_5 + 4y_6 + y_7 + \frac{1}{2}y_7 + 2y_8 + \frac{1}{2}y_9 \}$$

$$= \frac{h}{3} \{ \frac{1}{2}y_1 + 2y_2 + 1\frac{1}{2}y_3 + 4y_4 + 2y_5 + 4y_6 + 1\frac{1}{2}y_7 + 2y_8 + \frac{1}{2}y_9 \}$$

In the same way we may insert intermediate ordinates at any part of curve, provided the total number of ordinates is odd.

CHAPTER XIX

MEAN VALUES BY INTEGRATION

138. IN Chapter IX. we have shown how to find the mean value of one variable with respect to another.

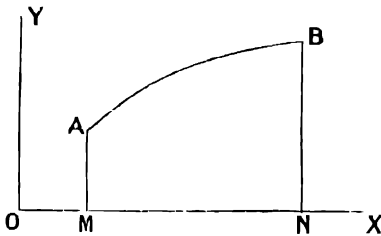

FIG. 111.

If we plot a curve **AB**, Fig. 111, representing the variable y as a function of x , then the mean value of y with respect to x is the height of a rectangle standing on the base **MN** of the same area as the area **ABNM** between the curve and the axis of x .

But the area enclosed by the curve **AB**, the axis of x , and the ordinates at $x = a$ and $x = b$ is equal to $\int_a^b y dx$, and the base **MN** is equal to $b - a$.

\therefore the mean value of y between $x = a$ and $x = b$ is

$$\frac{\int_a^b y dx}{b - a}$$

Thus, if we know and can integrate the expression for y in terms of x , the mean value of y can be calculated.

EXAMPLE (1).—Find the mean value of $3\sqrt{x}$ from $x = 0$ to $x = 4$.

In the figure, **OP** is the curve $y = 3\sqrt{x}$ from $x = 0$ to $x = 4$.

The area **OPM** = $\int_0^4 3\sqrt{x} dx$

$$= \left[x^{\frac{3}{2}} \right]_0^4 = 16.$$

\therefore mean value of $3\sqrt{x}$ = (height of a rectangle of area 16 and base 4) = 4.

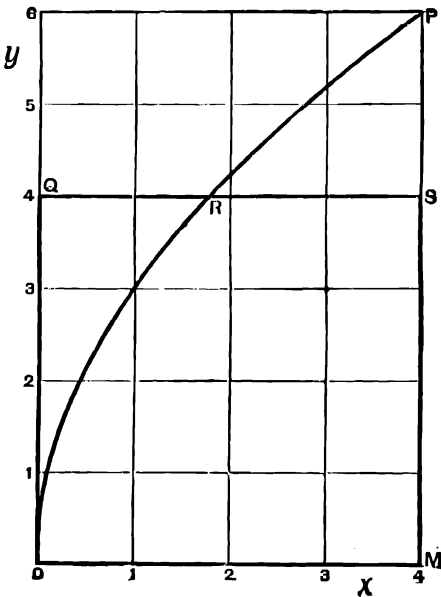

FIG. 112.

EXAMPLE (2).—Find the mean value of $\sin x$.

Here the curve is of a regular wave form, so that if we consider a complete period there is as much of the area positive as negative, and the mean value over a complete period is zero.

We may get the mean numerical value of $\sin x$ by considering half a period from $x = 0$ to $x = \pi$ radians.

$$\begin{aligned} \text{Area} &= \int_0^{\pi} \sin x dx = 2 \\ \text{base} &= \pi \\ \therefore \text{mean value} &= \frac{2}{\pi} = 0.637 \end{aligned}$$

This was obtained by the graphic method in example 10, p. 167.

EXAMPLE (3).—Find the average pressure in example 12, p. 167, by integration.

$$\begin{aligned} \text{We have } pv &= 100 \quad \therefore p = \frac{100}{v} \\ \text{The average pressure} &= \frac{\int_2^{10} p dv}{8} = 12.5 \int_2^{10} \frac{dv}{v} \\ &= 12.5 (\log_e 10 - \log_e 2) \\ &= 12.5 (\log_5 10) = 20.11 \end{aligned}$$

EXAMPLE (4).—In a simple periodic motion the distance s from a fixed point on the path at time t is given by the equation $s = a \sin nt$. Find the mean values of the velocity and acceleration from $t = 0$ to $t = \frac{\pi}{2n}$.

$$\begin{aligned} \text{We have velocity} &= \frac{ds}{dt} = an \cos nt \\ \therefore \text{mean velocity} &= \frac{\int_0^{\frac{\pi}{2n}} an \cos nt dt}{\frac{\pi}{2n}} \\ &= \frac{2n}{\pi} \left[a \sin nt \right]_0^{\frac{\pi}{2n}} \\ &= \frac{2na}{\pi} \\ \text{acceleration} &= \frac{d^2s}{dt^2} = -an^2 \sin nt \\ \therefore \text{mean acceleration} &= \frac{\int_0^{\frac{\pi}{2n}} (-an^2 \sin nt) dt}{\frac{\pi}{2n}} = -\frac{2n^2a}{\pi} \end{aligned}$$

This is the time average of the acceleration; to find the space average of the acceleration we have

$$\text{Acceleration} = -an^2 \sin nt = -n^2s$$

Also as t increases from 0 to $\frac{\pi}{2n}$, s increases from 0 to a .

$$\begin{aligned} \therefore \text{mean acceleration} &= \frac{\int_0^a -n^2 s \, ds}{a} \\ &= -\frac{n^2}{a} \cdot \left[\frac{s^2}{2} \right]_0^a = -\frac{n^2 a}{2} \\ &= \text{half the value of the acceleration when } s \text{ has its maximum} \\ &\quad \text{value } a. \end{aligned}$$

139. Root Mean Square Values.—In taking measurements of alternating electric currents and electro-motive forces, instruments are used of which the readings depend upon the "Root Mean Square" of the value of the current or electro-motive force.

If i is the current regarded as a function of the time t , the root mean square value of i is the square root of the mean value of i^2 taken over one period or any exact multiple of one period.

The abbreviation R.M.S. is often used for root mean square.

EXAMPLE.—Find the R.M.S. value of the current $i = 100 \sin 240 \pi t$, where i amps. is the current at time t seconds.

i goes through a complete period when $240\pi t$ increases by 2π , i.e. when $120t$ increases by 1, and $\therefore t$ increases by $\frac{1}{120}$ second.

\therefore mean value of i for one period

$$\begin{aligned} &= \frac{\int_0^{\frac{1}{120}} 100^2 \sin^2 240\pi t \, dt}{\frac{1}{120}} \\ &= 120 \times 10^4 \times \frac{1}{2} \int_0^{\frac{1}{120}} (1 - \cos 480\pi t) \, dt \\ &= 6 \times 10^4 \left[t - \frac{\sin 480\pi t}{480\pi} \right]_0^{\frac{1}{120}} \\ &= 6 \times 10^4 \times \frac{1}{120} = \frac{1}{2} \times 100^2 \end{aligned}$$

$$\therefore \text{R.M.S. value} = \sqrt{\frac{1}{2} \times 100^2} = \frac{100}{\sqrt{2}}$$

Note that this is equal to the maximum value of the current divided by $\sqrt{2}$.

Similarly it can be shown in general that the R.M.S. value of $A \sin pt$ is $\frac{A}{\sqrt{2}}$.

EXAMPLES.—LXXIX.

Find the mean values of the following:—

1. x^2 between $x = 0$ and $x = 2$.
2. $x^{\frac{1}{2}}$ between $x = 0$ and $x = 3$.
3. x^{-2} between $x = 1$ and $x = 2$.
4. $x^{\frac{1}{3}}$ between $x = 0$ and $x = 2$.
5. e^x between $x = -1$ and $x = 0$.
6. e^{3x} between $x = -\frac{1}{3}$ and $x = +\frac{1}{3}$.
7. $e^{\frac{1}{2}x}$ between $x = -3$ and $x = +3$.
8. e^{2x} between $x = 0$ and $x = \frac{1}{2}$.
9. $A \sin x$ between $x = 0$ and $x = \frac{\pi}{2}$.

10. If a body falls vertically from rest, its velocity v at the end of t seconds is given by the equation $v = 32 \cdot 2t$. Find the average velocity (a) for the first second, (b) for the first six seconds of its motion.

11. Find the mean value of $\sin pt$ from $t = 0$ to $t = \frac{\pi}{p}$.
12. Find the mean value of $\cos pt$ from $t = 0$ to $t = \frac{\pi}{p}$.

Find the mean values of the following expressions in which p and q are whole numbers :—

13. $(A \sin pt)(V \sin qt)$ from $t = 0$ to $t = 2\pi$.

14. $(A \sin pt)(V \sin qt)$ from $t = 0$ to $t = 2\pi$.

15. $(A \cos pt)(\cos qt)$ from $t = 0$ to $t = 2\pi$.

16. v cub. ft. is the volume of a quantity of gas at pressure p lbs. per square inch. If the gas expands so as to follow the law $pv = 100$, find the average pressure between volumes 1 cub. ft. and 3 cub. ft.

17. A quantity of steam expands so as to follow the law $pv^{1.3} = 200$, p being measured in lbs. to the square inch. Find the average pressure between volumes 2 and 4.

18. A quantity of steam expands so as to follow the law $pv^{1.13} = 4000$ p being measured in lbs. to the square foot. Find the mean pressure from $v = 1$ to $v = 10$.

19. A spring oscillates so that the force F lbs. which it exerts on a weight at the end of time t seconds is given by the equation $F = 2 \sin 3t$. Find the mean value of the force from $t = 0$ to $t = \frac{\pi}{3}$.

20. A particle moves along the axis of x so that the force upon it at a distance x from the origin is equal to ax where a is a constant. Find the mean value of the force as x increases from 0 to s .

21. The electric current C in a conductor at time t is given by the equation $C = 4 \sin 200t$. Find the mean value of C throughout the following intervals of time :—

(1) $t = 0$ to $t = 0.031416$ secs. $= \frac{\pi}{100}$.

(2) $t = 2.5$ to $t = 2.531416$ secs.

(3) $t = 0$ to $t = 0.015708$ secs. $= \frac{\pi}{200}$.

22. The voltage V at time t in an alternating current circuit is equal to $100 \sin 300t$. The current is equal to $2 \sin (300t - \alpha)$ amps. The power in watts is the mean value of the product of the current and the voltage. Find the power (1) when $\alpha = 0$, (2) when $\alpha = 45^\circ = 0.7854$ radian, (3) when $\alpha = 90^\circ = 1.5708$ radian.

23. Prove that if $C = C_0 \sin qt$ and $V = V_0 \sin (qt - \alpha)$ then the mean value of $CV = \frac{1}{2} C_0 V_0 \cos \alpha$.

Find the R.M.S. values of the following :—

24. $2 \sin 3t$.

25. $5 \cos 2t$.

26. $3 \sin (2t + 1)$.

27. $\sin pt$.

28. $\cos pt$.

29. $A \sin (pt + a)$.

30. An alternating E.M.F. of e volts is given by the equation $e = 100 \sin 1000t$, where t is the time in seconds. Find the R.M.S. value of e , and verify by the graphic method.

31. If $i = \frac{E}{R} + a \sin qt$, where E , R , a , and q are constants, find the R.M.S. value of i .

32. Find the R.M.S. value of $A \sin pt + B \sin qt$. A , B , p , and q are constants.

33. Find the R.M.S. value of $A \sin (pt + \alpha) + B \sin (qt + \beta)$. A , B , p , q , α and β are constants.

CHAPTER XX

VECTOR ALGEBRA—ADDITION OF VECTORS

140. Scalar and Vector Quantities.—Consider the point **A** in the figure as capable of being moved about the paper.

We shall speak of the operation of moving the point **A** from one position to another as a **displacement of A**. In order to give complete directions for any displacement of the point **A**, we must evidently specify (1) the distance through which the point **A** is to be moved ; (2) the direction of that motion.

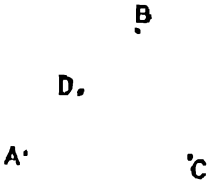

FIG. 113.

Thus we cannot say that we perform the same operation in moving **A** to **B** as in moving **A** to **C**, because, although the distances **AB** and **AC** are equal, the directions of the two displacements are not the same.

Also, the displacement of **A** to **D** is not the same operation as the displacement of **A** to **B**, because, though the directions of the two displacements are the same, the distances are different. Thus a displacement is a different kind of magnitude from such quantities as the area of a figure, the mass of a body, the work done by a force, the temperature of a body, the electrical resistance of a conductor, etc.

The area of a body is completely known when we know how many units of area it contains : the work done by a force is completely known when we know the number of foot-pounds by which it is measured, and so on.

We find that any one of the latter class of quantities can be expressed by a single arithmetical number.

On the other hand, we find that there is a class of quantities such as velocity, acceleration, force, momentum, impulse, electric current, etc., which resemble a displacement in that we require to know not only the numerical magnitude, but also the direction in order to describe them completely.

Quantities which can be completely described by means of an arithmetical number expressing the number of times they contain a single unit are called **scalar quantities**.

Quantities which have direction as well as numerical magnitude, and can only be completely specified by stating *both size or numerical magnitude and direction*, are called **vector quantities**.

The numerical magnitude of a vector, such as, for example, the number of feet or centimetres in a displacement, is sometimes called its **tensor**, and the direction is sometimes called the **ort** of the vector.

We shall speak of the **size** and **direction** of the vector.

All kinds of vectors can be completely represented by displacement vectors, the length of the displacement representing the size, and its direction representing the direction of the vector.

In what follows we shall speak with direct reference to displacement vectors ; these will be represented by straight lines, an arrow-head being

used to show the direction of the displacement along the straight line which represents it; we shall speak of the straight line itself as a vector, regarding the operation of drawing it as a displacement.

Thus in the figure, \overline{AB} represents a displacement from A to B , \overline{CD} a displacement from C to D . \overline{BA} is used to denote a displacement from B to A .

In this book we shall follow Mr. Heaviside in using *clarendon* type to denote that a letter is intended to represent a vector; thus \mathbf{a} means a certain vector having a definite size and direction.

a means a number used as in ordinary arithmetic and algebra, expressing the size of the vector \mathbf{a} , and has no reference to direction.

In written work it will be found convenient to underline a letter when it represents a vector. Thus, in his own work, the student should underline all letters which would be printed in *clarendon* type on the system followed in this book.

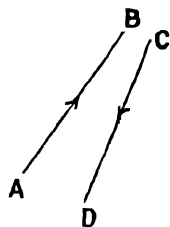

FIG. 114.

141. Specification of Vectors.—We shall employ the following method of specifying the size and direction of vectors in a plane.

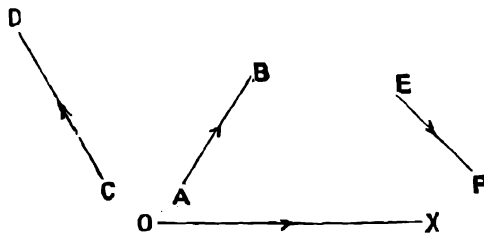

FIG. 115.

Suppose a base line OX to be drawn from left to right, as in specifying the rectangular co-ordinates of a point on a plane. Then the direction of any vector is specified by the angle which it makes with OX . The angle is understood to be positive, *i.e.* it is the angle through which OX would have to be turned about O , in a direction opposite to the motion of the hands of a clock in order to make its direction the same as that of the vector.

The angle expressing the direction is written after and below the number expressing the size of the vector.

Thus, 3_{57° represents a vector of size 3 units, whose direction makes an angle of 57° with OX . This is represented by the straight line AB in Fig. 115.

The straight line CD represents the vector 4_{120° .

Note that attention must be paid to the direction of the arrow-head on the straight line representing the vector, and this must always be inserted; *e.g.* it might seem that EF makes an angle of 45° with OX , but OX could only be brought to the direction EF by a positive rotation of 315° , and the symbol for the vector EF is $2'5_{315^\circ}$.

We might also specify the directions of vectors by reference to the points of the compass, representing these on the paper as they are usually represented on a map.

Thus AB in Fig. 115 is a vector of 3 units in a direction 57° N. of E. EF is a vector of 2'5 units in a direction S.E.

EXAMPLES.—LXXX.

Draw straight lines to represent the following vectors, and specify the direction of each by reference to the points of the compass :—

1. $5 \cdot 2_{72^\circ}$. 2. $3 \cdot 4_{134^\circ}$. 3. $5 \cdot 6_{211^\circ}$. 4. $2 \cdot 3_{280^\circ}$. 5. $3 \cdot 4_{321^\circ}$.

142. Equal Vectors.—Two vectors are said to be equal when they have the same sign and direction, although their positions may be different.

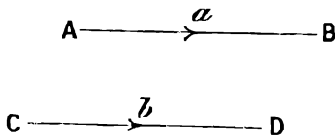

FIG. 116.

Thus two equal vectors are represented by equal and parallel straight lines, and the equation

$$a = b$$

in vector algebra means that the straight lines representing a and b are not only of equal length but are also parallel.

It follows by elementary geometry that with this meaning of the sign “ = ” if $a = b$ and $c = b$, then $a = c$.

Thus the sign “ = ” in vector algebra obeys the same law as in ordinary scalar algebra.

143. Addition of Vectors.—Consider the case of a yacht sailing against the wind from a point **A** to a point **B**, the distance **AB** being 7 miles in a direction due E.

Then, when the vessel reaches **B**, there is evidently a sense in which we may say that she has sailed 7 miles in an easterly direction, although, owing

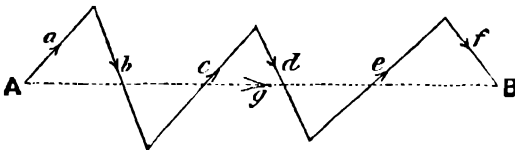

FIG. 117.

to the necessity of tacking, the straight line **AB** does not represent her actual course, which is represented by a, b, c, d, e, f in the figure.

Then, although the vessel has undergone a series of displacements a, b, c, d, e, f , her “nett” displacement is the vector g from **A** to **B**.

A single displacement equal to g would have carried her from her starting-point to the point where her course ended.

In vector algebra the vector g is said to be the sum of the vectors a, b, c, d, e, f , and the sign + is used to express this kind of addition.

Thus the equation

$$a + b + c + d + e + f = g$$

means that if we draw a straight line to represent the vector a , and from the end of this a straight line to represent b , and so on ; then g is the vector represented by a straight line drawn from the beginning of a to the end of f .

Note that the sign “ + ” between two vectors is not a direction to add their numerical magnitudes together.

EXAMPLE.—To find the value of $3_{40^\circ} + 4_{253^\circ} + 3_{330^\circ}$.

Draw the straight lines $AB = 3_{40^\circ}$, $BC = 4_{253^\circ}$, $CD = 3_{330^\circ}$ as in Fig. 118. Join **AD**.

Then by measurement we find that the length of AD is 4.85 , and that it makes an angle of 330° with OX ,

$$\therefore \text{the required vector sum is } 3_{100} + 4_{235} + 3_{350} = 4.85_{330}$$

We should of course get a very different result if the sign $+$ in the above equation had the same meaning as in arithmetic.

144. Zero.—Note in particular that the sum of a number of displacement vectors which form a closed figure is zero, for the point which is supposed to undergo the displacements comes back to its starting position, and its nett displacement is zero.

EXAMPLE.—To find the value of $3_{100} + 4_{235} + 3_{350} + 4.85_{150}$.

These are represented by the straight lines AB, BC, CD, DA in Fig. 118, so that when the tracing point has undergone the above four displacements in succession it has returned to A , and its nett displacement has been the same as if it had not been displaced at all, *i.e.* $3_{100} + 4_{235} + 3_{350} + 4.85_{150} = 0$. This defines the meaning of the symbol "0" in vector algebra.

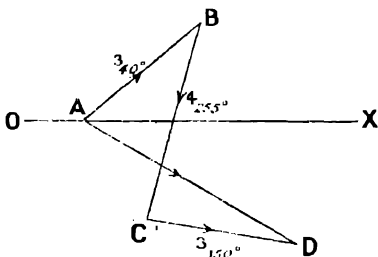

FIG. 118.

145. Composition of Velocities, Accelerations, etc.—We here take it as self-evident that displacement vectors are added by the method explained above.

A velocity is the rate of change of a displacement with respect to the time, and therefore this method of addition also holds good for velocities.

If a point has several simultaneous velocities in different directions, their vector sum is the resultant velocity of the point. In the same way it follows, since an acceleration is the rate of change of a velocity vector with respect to the time, that this method of addition also holds good for accelerations. Since a force is measured by the acceleration which it tends to cause, it follows that the same method also holds good for force vectors. Other vectors quantities, such as Momentum, Impulse, Magnetic Induction, etc., can be derived from displacement or force vectors by multiplying them by scalar quantities, and thus the same law of addition holds for all vector quantities.

We see that the law of vector addition includes, as special cases, the propositions known as the Parallelogram of Velocities, the Parallelogram of Accelerations, the Parallelogram of Forces, etc. In particular, the statement that when a number of vectors taken in order form a closed figure their sum is zero, is equivalent to the polygon of velocities when the vectors are velocities, and to the polygon of forces when they are forces.

EXAMPLES. — LXXXI.

In the following examples give the angular measurements in the results correct to one-half of a degree. Find the following vector sums:—

1. $3_{30} + 5_{135}$. 2. $3_{30} + 5_{135} + 4_{150}$. 3. $7_{07} + 9_{70} + 5_{280}$.

4. $8.01_{27} + 9.4_{100} + 7.95_{225}$. 5. $3_{20} + 5_{150} + 4_{300}$.

6. $5_{110} + 10_{160} + 5.85_{325}$. 7. $3_{10} + 5_{115} + 4_{71}$.

8. $6_{0} + 4_{135} + 8_{225} + 7_{90}$. 9. $7_{0} + 3_{90} + 3_{180} + 8_{270} + 4_{180}$.

10. A ship sails the following course: 3 miles in direction N.E., then 3 miles in direction 30° S. of E., then 5 miles in direction due N., then 2 miles in direction

30° S. of E. At the end of her course how far, and in what direction, does the vessel lie from her starting point?

11. The following forces act at a point. Find the numerical magnitude and direction of their resultant.

15 lbs.	making an angle of 48°	with ox	
20	"	"	162° " ox
33	"	"	202° " ox
14	"	"	300° " ox

12. Find the resultant of the following forces:—

15 lbs.	making an angle of 25°	with ox	
12	"	"	141° " ox
10	"	"	250° " ox

13. A cricket ball is travelling in a direction **AB** with a momentum of 125 units. It receives a blow in a direction **BC**, which gives to it a momentum of 100 units. The angle **ABC** is 42°. In what direction will it move after the blow? What is the numerical magnitude of its momentum after the blow?

NOTE.—The momentum of a body is equal to its mass multiplied by its velocity, and has therefore the same direction as the velocity. The final momentum is the vector sum of the momentum before the blow, and the momentum given to the ball by the blow.

146. Rules governing the Use of the Sign "+."

Let a and b be any two vectors.

Construct a parallelogram **ABCD**, so that $AB = DC = a$ and $AD = BC = b$.

$$\begin{aligned} \text{Then } a + b &= AB + BC = AC \\ \text{and also } b + a &= AD + DC = AC \\ \therefore a + b &= b + a \end{aligned}$$

i.e. the sum of two vectors does not depend on the order in which they are taken.

This is the **Commutative Law of Addition**. We already know that

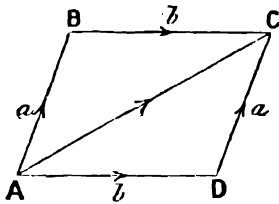

FIG. 119.

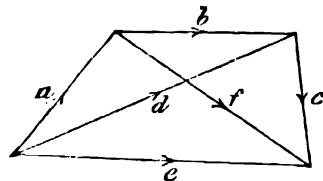

FIG. 120.

it holds for ordinary arithmetical addition, and we have here shown that it is also true when the sign + has the special meaning given to it in vector addition.

Brackets are used as in ordinary algebra to indicate that the terms which they contain are to be taken together. Thus, in the expression $(a + b) + c$, the bracket indicates that $a + b$ is considered as one vector to which the vector c is added.

If a, b, c, d, e, f are vectors, as shown in Fig. 120, the expression $(a + b) + c$ denotes $d + c$, which is equal to e , and is the same as $a + b + c$.

Similarly, $a + (b + c) = a + f = e = a + b + c$.

$$\therefore a + (b + c) = a + b + c = (a + b) + c$$

Similarly, in adding together any number of vectors we may take any two or more together in a bracket without altering the sum.

This is the **Associative Law of Addition**. We have here shown that it holds for vector addition as well as for arithmetical addition.

To show that the commutative law holds for more than two vectors, we have

$$\begin{aligned} a + b + c &= a + (b + c) \\ &= (b + c) + a \text{ by the commutative law for two vectors} \\ &= b + c + a \end{aligned}$$

Similarly, we can show that

$$a + b + c = b + a + c = c + a + b, \text{ etc.}$$

And that the commutative law holds for the addition of any number of vectors.

EXAMPLES.—LXXXII.

1. Starting at the same point o , find by construction on the same paper the following vector sums. Verify that they are all equal.

$$\begin{aligned} 3_{15^\circ} + 5_{90} + 3_{200^\circ} + 7_{90} \\ 5_{90} + 3_{15^\circ} + 7_{90} + 3_{200^\circ} \\ 3_{200^\circ} + 5_{90} + 7_{90} + 3_{15^\circ} \\ 7_{90} + 3_{200^\circ} + 5_{90} + 3_{15^\circ} \end{aligned}$$

2. $a = 4_{30^\circ}$, $b = 2 \cdot 7_{200^\circ}$, $c = 3 \cdot 3_{18^\circ}$, $d = 3 \cdot 7_{200^\circ}$.

Find by three separate constructions the values of

$$(a + b), (c + d) \text{ and } (a + b) + (c + d).$$

Find in the same way the values of

$$(a + c), (b + d) \text{ and } (a + c) + (b + d), \text{ and of } (c + d + a) \text{ and } (c + d + a) + b.$$

Verify that $(a + b) + (c + d) = (a + c) + (b + d) = (c + d + a) + b$.

3. Find the values of

$$\begin{aligned} 26_{30^\circ} + 37_{115^\circ} + 41_{200^\circ} \\ \text{and } 26_{30^\circ} + 41_{200^\circ} + 37_{115^\circ} \end{aligned}$$

and verify that they are the same.

147. Use of the Sign “-.”

The sign “-” before a vector indicates that its direction is reversed.

For example, $-a$ is a vector of the same numerical magnitude as the vector $+a$, but in the opposite direction.

-5_{69° is a vector of 5 units in a direction opposite to that of the vector 5_{69° .

Evidently it is the same as a positive vector 5_{249° .

If a and b are two displacement vectors, $a - b$ is the nett displacement of a point which is moved along the vector a , and then for a distance b in a direction opposite to that of the vector b .

In the figure $c = a - b$.

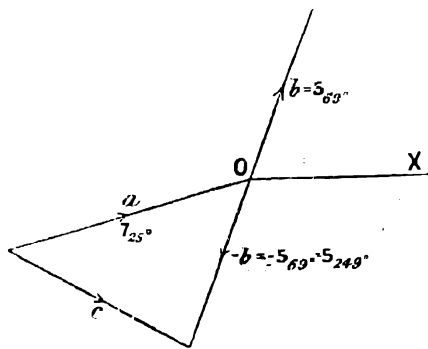

FIG. 121.

$$\begin{aligned} \text{If } a &= 7_{25^\circ} \text{ and } b = 5_{69^\circ} \\ \text{Then } -b &= 5_{249^\circ} \\ \text{and } a - b &= 7_{25^\circ} - 5_{69^\circ} = 7_{25^\circ} + 5_{249^\circ} \end{aligned}$$

Thus, in any expression a vector with the $-$ sign before it may always be replaced by an equal and opposite vector with the $+$ sign before it.

It follows that the laws shown, in § 146, to hold for the $+$ sign, also hold for the $-$ sign.

Note in particular that

$$-(a + b + c + d + e + f) = -a - b - c - d - e - f$$

For in Fig. 117 the expression on the right-hand side of this equation would be represented by reversing all the arrow-heads, and would represent the case where the ship sails back over the same courses from B to A.

Evidently the resulting nett displacement is

$$-g = -(a + b + c + d + e + f)$$

In ordinary algebra, if it is given that $a = b$ and $c = d$, we take it as self-evident that $a \pm c = b \pm d$.

Consider the corresponding case when a, b, c, d are displacement vectors.

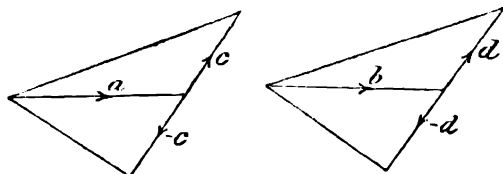

FIG. 122.

If a and b are equal displacements, and also c and d , it is evident that the double displacement $a \pm c$ has the same effect in changing the position of a point as the double displacement $b \pm d$; *i.e.*

$$a \pm c = b \pm d$$

Note that this is equivalent to the proposition (Euclid I, 4) that two triangles are equal when two sides and the included angle of one are respectively equal to two sides and the included angle of the other.

We have now shown that the signs $+$, $-$, and $=$ obey the same rules in vector algebra as in ordinary algebra.

It follows that in vector equations we may transfer a term from one side to the other provided we change its sign.

The fundamental laws of vector addition and subtraction have been treated with some fulness to enable the student to realize the actual meaning of the symbols he uses as representing the vectors themselves. The student should be careful to avoid the habit of dealing mechanically with the expressions and processes of vector algebra as if he were dealing with mere symbols.

EXAMPLE (1).—If $a = 6_{90^\circ}$, $b = 7_{45^\circ}$, $c = 4_{30^\circ}$, find the values of $a + b - c$ and $a - b + c$.

$-b$ is the same as the positive vector 7_{225°

$-c$ is the same as the positive vector 4_{210°

Thus in the figure

$$P = a + b - c \text{ and } Q = a - b + c.$$

We find by measurement that

$$P = 7.16_{21^\circ}, \quad Q = 5.4_{328^\circ}$$

measuring the angles to the nearest degree.

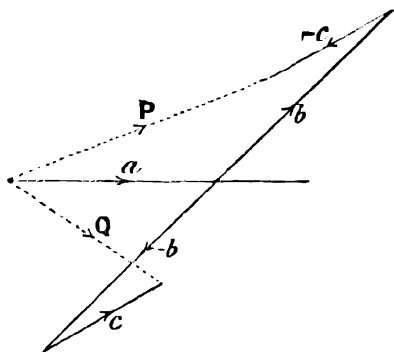

FIG. 123.

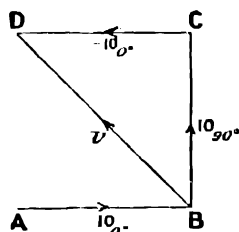

FIG. 124.

EXAMPLE (2).—Water is flowing at 10 feet per second along a pipe having a right-angled bend. What is the vector change of the velocity at the bend?

(Board of Education Examination in Applied Mechanics.)

In the figure (Fig. 124), velocity along AB before reaching bend = 10_{0° ,
velocity along BC after passing bend = 10_{90° ,

$$\therefore \text{change of velocity } v = 10_{90^\circ} - 10_{0^\circ}$$

where the $-$ sign has the meaning given to it in vector algebra.

In the figure AB represents 10_{0° , BC represents 10_{90° . To find v draw CD to represent -10_{0° . Then $v = 10_{90^\circ} - 10_{0^\circ} = BC + CD = BD$. By measurement or calculation $BD = 14.14$ and the angle $ABD = 45^\circ$,

$$\therefore v = 14.14_{135^\circ}.$$

The required vector change of velocity at the bend is therefore a velocity of 14.14 feet per second in a direction bisecting the angle at the bend.

148. Relative Velocity.

If a point A moves with velocity u , and a point B moves with velocity v , then the velocity of A relative to B, i.e. the velocity which A would appear to have to a person moving with B and facing in a constant direction, is $u - v$, where u and v are regarded as vectors, and the sign $-$ has, of course, the meaning given to it in vector algebra.

EXAMPLE.—A vessel A is sailing at a speed of 10 knots in a direction N.E., and a vessel B is sailing at 12 knots in a direction 20° W. of S. Find the velocity which A appears to have to a person on B.

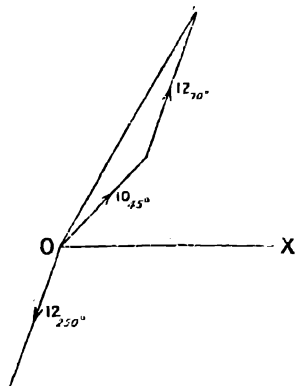

FIG. 125.

We may write

velocity of **A** = $u = 10_{45}^{\circ}$

velocity of **B** = $v = 12_{25}^{\circ}$

$$\begin{aligned} \therefore \text{velocity of A relative to B} &= u - v \\ &= 10_{45}^{\circ} - 12_{25}^{\circ} \\ &= 10_{45}^{\circ} + 12_{70}^{\circ} \\ &= 21'47_{58.50} \end{aligned}$$

by construction and measurement.

EXAMPLES.—LXXXIII.

Find by construction the values of—

1. $3_{25}^{\circ} - 5_{35}^{\circ} + 4_{30}^{\circ}$. 2. $7_{87}^{\circ} + 9'7_{90}^{\circ} - 5_{100}^{\circ}$. 3. $8'01_{27}^{\circ} - 9'4_{310}^{\circ} - 7'95_{203}^{\circ}$.

4. If $a = 3_{34}^{\circ}$, $b = 2_{11}^{\circ}$, $c = 3_{23}^{\circ}$, find the values of $a + b + c$ and $a - b + c$.

5. $a = 3_{48}^{\circ}$, $b = 2_{12}^{\circ}$, $c = 4_{31}^{\circ}$, find the values of $a + b + c$ and $a + b - c$.

6. A point **A** has a velocity 135_{15}° , a point **B** has a velocity 210_{28}° . Find the velocity of **B** relative to **A**.

7. A vessel **A** is sailing at 11 knots in a direction S.E., and a second vessel **B** is sailing at 13 knots in a direction 10° E. of N. Find the velocity of **A** relative to **B**.

8. A body is moving at a speed of 150 ft. per second in a direction **AB**. It strikes an obstacle and rebounds at a speed of 110 ft. per second in a direction **BC**. The angle **ABC** is 125° . What is the magnitude and direction of the velocity which is given to the body by the blow?

149. Multiplication of a Vector by a Scalar Quantity.—If a be any vector and n any number, an or na denotes a vector in the same direction as a , but n times as large; e.g. if $a = 2_{60}^{\circ}$, $3a$ denotes a displacement of 6 units in a direction making 59° with **OX**.

Let a, b, c be three vectors, and let

$$a + b + c = f$$

Draw the construction to find the sum $a + b + c$.

Then the sum $2a + 2b + 2c$ will be found by drawing a similar and similarly situated figure on twice the scale.

By elementary geometry the resulting vector sum will be parallel to f and of twice the length, i.e.

$$2a + 2b + 2c = 2f = 2(a + b + c)$$

and, in general, when n is any scalar number

$$na + nb + nc + \dots = n(a + b + c \dots)$$

Thus we may "multiply out" each term in a bracket by a scalar quantity as in ordinary algebra.

This is the **Distributive Law of Multiplication**.

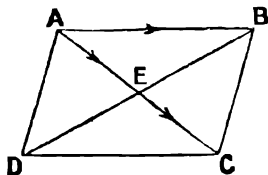

FIG. 126.

EXAMPLE.—To prove that the diagonals of a parallelogram bisect one another.

Let the diagonals **AC**, **BD** of the parallelogram **ABCD** intersect at **E**. Then the vector $\overrightarrow{AB} = \overrightarrow{DC}$, the sign = here expressing equality of direction as well as equality of numerical magnitude. But the vector sum

$$\overrightarrow{AE} + \overrightarrow{EB} = \overrightarrow{AB}, \quad \text{and } \overrightarrow{DE} + \overrightarrow{EC} = \overrightarrow{DC}$$

$$\therefore \overrightarrow{AE} + \overrightarrow{EB} = \overrightarrow{DE} + \overrightarrow{EC}$$

$$\overrightarrow{AE} - \overrightarrow{EC} = \overrightarrow{DE} - \overrightarrow{EB} \quad (\text{see } \S 147)$$

But the vector differences on each side of this equation are vectors having different directions, and therefore cannot be equal unless they are both equal to zero,

$\therefore AE - EC = 0$, and $AE = EC$; $DE - EB = 0$, and $DE = EB$

which proves the proposition.

EXAMPLES.—LXXXIV.

1. **AC** and **BD** are two straight lines bisecting one another at **E**. Prove that **AB** is equal and parallel to **DC**.

2. If **AB** is equal and parallel to **CD**, prove by vector algebra that **AC** is equal and parallel to **BD**.

3. **D** is the mid-point of the side **BC** of a triangle **ABC**. A point **G** is taken on **AD** so that $AG = 2GD$. Prove by vector algebra that **CG** and **BG** when produced bisect **AB** and **AC**.

4. Prove that the figure formed by joining the mid-points of the sides of any quadrilateral is a parallelogram.

150. To find the Resultant of two Like Parallel Forces.

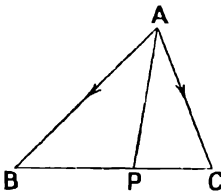

FIG. 127.

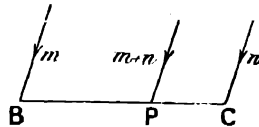

FIG. 128.

Let forces represented by $m\mathbf{AB}$, $n\mathbf{AC}$ act at **A**.

AB and **AC** are linear displacement vectors, and m and n are scalar quantities.

Join **BC**. Divide **BC** at **P**, so that $BP : PC = n : m$.

$$\therefore m \cdot BP = n \cdot PC \dots \dots \dots (1)$$

Now in vector notation $m\mathbf{AB} = m(\mathbf{AP} + \mathbf{PB}) = m\mathbf{AP} + m\mathbf{PB} = m\mathbf{AP} - m\mathbf{BP}$

and $n\mathbf{AC} = n(\mathbf{AP} + \mathbf{PC}) = n\mathbf{AP} + n\mathbf{PC}$

$$\therefore \text{adding, } m\mathbf{AB} + n\mathbf{AC} = (m + n)\mathbf{AP} - m\mathbf{BP} + n\mathbf{PC} = (m + n)\mathbf{AP} \text{ by (1)}$$

The sum of two force vectors is their resultant; \therefore the resultant of forces $m\mathbf{AB}$ along **AB**, and $n\mathbf{AC}$ along **AC**, is $(m + n)\mathbf{AP}$ along **AP**.

The position of **P** is evidently independent of the position of **A** so long as the ratio $m : n$ remains the same, so that **A** may be moved as far away from **BC** as we please.

As **A** moves to a greater and greater distance from **BC**, the three lengths **AB**, **AP**, **AC** become more and more nearly equal and parallel.

Choose the scale so that **AP** represents the unit force.

Then, in the limit, as **A** moves to infinity, Fig. 127 becomes Fig. 128, and **AB** and **AC** become equal to **AP**, and the resultant of two like parallel forces m and n at **B** and **C** is $m + n$ at **P**, where **P** divides **BC** so that $BP : PC = n : m$.

151. Centre of a System of Parallel Forces.—Similarly, to find the resultant of the three forces

$$m_1\mathbf{AB}, m_2\mathbf{AC}, m_3\mathbf{AD}$$

We have, in vector notation,

$$m_1\mathbf{AB} + m_2\mathbf{AC} = (m_1 + m_2)\mathbf{AP} \text{ where } BP : PC = m_2 : m_1$$

∴ the vector sum

$$\begin{aligned} m_1\mathbf{AB} + m_2\mathbf{AC} + m_3\mathbf{AD} &= (m_1 + m_2)\mathbf{AP} + m_3\mathbf{AD} \\ &= (m_1 + m_2 + m_3)\mathbf{AG} \text{ by the last paragraph} \\ \text{where } \mathbf{PG} : \mathbf{GD} &= m_3 : (m_1 + m_2) \end{aligned}$$

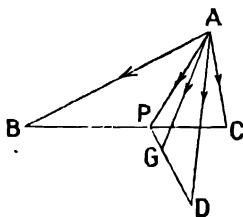

FIG. 129.

i.e. the resultant of forces $m_1\mathbf{AB}$, $m_2\mathbf{AC}$, $m_3\mathbf{AD}$ along \mathbf{AB} , \mathbf{AC} , and \mathbf{AD} is

$$(m_1 + m_2 + m_3)\mathbf{AG} \text{ along } \mathbf{AG}$$

When \mathbf{A} is taken to infinity the vectors \mathbf{AB} , \mathbf{AC} , \mathbf{AD} , \mathbf{AG} become equal and parallel.

Taking \mathbf{AG} to represent the unit force, we get the theorem that the resultant of parallel forces m_1 at \mathbf{B} , m_2 at \mathbf{C} , and m_3 at \mathbf{D} is $(m_1 + m_2 + m_3)$ at \mathbf{G} . It is evident that the position of \mathbf{G} does not depend upon the direction in which \mathbf{A} is taken to infinity, and therefore the parallel forces at \mathbf{B} , \mathbf{C} , and \mathbf{D} may act in any direction, but their resultant will still act at the same point \mathbf{G} . \mathbf{G} is called the centre of the system of parallel forces. If the parallel forces are weights, \mathbf{G} is the centre of gravity of the weights m_1 at \mathbf{B} , m_2 at \mathbf{C} , and m_3 at \mathbf{D} .

We may evidently extend this to the case of any number of parallel forces. Thus, if we have weights m_1 at \mathbf{P}_1 , m_2 at \mathbf{P}_2 , m_3 at \mathbf{P}_3 , m_4 at \mathbf{P}_4 , and so on, the centre of gravity of the system of weights is at \mathbf{G} where \mathbf{G} is a point whose position is given by the vector equation

$$(m_1 + m_2 + m_3 + m_4 + \dots)\mathbf{OG} = m_1\mathbf{OP}_1 + m_2\mathbf{OP}_2 + m_3\mathbf{OP}_3 + m_4\mathbf{OP}_4 + \dots$$

where \mathbf{O} is any point, the lines \mathbf{OP}_1 , \mathbf{OP}_2 , ... \mathbf{OG} are understood to be vectors, and the signs + and = have the meaning which we have given to them in vector algebra.

This vector equation may be taken as a definition of the centre of gravity of a number of particles.

EXAMPLE.—Find by a graphic construction the position of the centre of gravity of the following weights:—

3 lbs.	at the point	\mathbf{P}_1	whose polar co-ordinates are	(5, 42°)
2	" "	\mathbf{P}_2	" "	(2, 25°)
4	" "	\mathbf{P}_3	" "	(3, 120°)
1	" "	\mathbf{P}_4	" "	(2, 70°)

The position of the points is shown in the figure. Consider the lines \mathbf{OP}_1 , \mathbf{OP}_2 , \mathbf{OP}_3 , \mathbf{OP}_4 as vectors. Then, if \mathbf{G} is the centre of gravity, we have shown that

$$10\mathbf{OG} = 3\mathbf{OP}_1 + 2\mathbf{OP}_2 + 4\mathbf{OP}_3 + \mathbf{OP}_4.$$

Find by construction the vector sum

$$3\mathbf{OP}_1 + 2\mathbf{OP}_2 + 4\mathbf{OP}_3 + \mathbf{OP}_4 = 10\mathbf{OG}.$$

Then $OP = 10 \cdot OG$.

$\therefore G$ is on OP at a distance OG equal to $\frac{1}{10}OP$ from O . We find by measurement that the polar co-ordinates of G are

$$r = 25.8, \theta = 60^\circ.$$

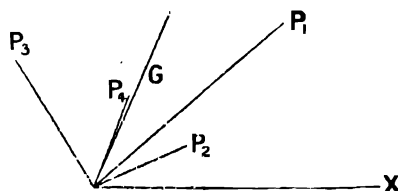

FIG. 130.

This method is given chiefly for its interest as an example in vector addition. In practice we use a more convenient method which is derived from this (see § 162).

EXAMPLES.—LXXXV.

1. Find the polar co-ordinates of the centre of gravity of the following weights:—

3	lbs.	at the point	whose polar co-ordinates are	$(2.24, 26.5^\circ)$.
1	"	"	"	$(2.06, 76^\circ)$.
2	"	"	"	$(1.12, 153.5^\circ)$.
10	"	"	"	$(1, 270^\circ)$.

2. Find the polar co-ordinates of the centre of gravity of:—

1	lb	at the point	whose polar co-ordinates are	$(5.83, 149^\circ)$.
4	"	"	"	$(9.43, 58^\circ)$.
5	"	"	"	$(13.45, 42^\circ)$.
3	"	"	"	$(21.5, 22^\circ)$.

3. Draw an equilateral triangle ABC having its sides two inches long. Find by construction the vector sum of forces proportional to $3AB$ along AB and $2AC$ along AC , and verify by measurement the theorem of § 150 that the resultant of the forces is $5AP$ along AP , where P divides BC so that $BP : PC = 2 : 3$.

4. Three equal weights are placed at the angular points $A, B,$ and $C,$ of a triangle $ABC.$ D is the mid-point of $BC.$ Prove that the centre of gravity G of the weights is on $AD,$ and that $AG = \frac{2}{3} AD.$

5. Prove by vector algebra that the centre of gravity of 4 equal weights at the corners A, B, C and D of a triangular pyramid is at a point G on the straight line AE joining the vertex to the centre of gravity E of the three weights at $B, C,$ and $D,$ and such that $AG = \frac{1}{4} AE.$

CHAPTER XXI

MULTIPLICATION OF VECTORS

152. Scalar Product of Two Vectors.—The scalar product of two vectors is defined as the product of their numerical magnitudes into the cosine of the angle between them.

If a and b are the two vectors and θ the angle between them, the scalar product is written ab , and we have

$$ab = ab \cos \theta$$

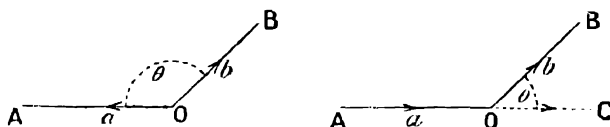

FIG. 131.

Note that the angle θ is taken between the directions of the two vectors a and b , measured both from or both towards the point where they meet.

E.g. if the vectors are in the directions OA and OB in the figure, θ is taken as the angle AOB ; if the vectors are in the directions AO and OB , however, the angle θ is the angle COB between AO produced and OB , and not the angle AOB .

As its name implies, the scalar product of two vectors is a scalar quantity and not a vector.

The physical meaning which it has and the units in which it is measured, depend on the original vectors which are multiplied together.

If two displacement vectors are multiplied together the resulting scalar product has the dimensions of an area which, of course, is a scalar quantity having no direction.

If a force F causes a displacement s in its own direction, the product Fs is the work done. We now extend this statement, and say that when F and s are vectors in any two directions, the scalar product Fs is the work done by the force F acting through the displacement s and remaining parallel to its original direction throughout the displacement. The work Fs is measured in foot-lbs. or similar units, and is a scalar quantity having numerical magnitude but no direction.

If a force F is moving a point with a velocity v in its own direction, the product Fv is the rate at which the force is doing work, and is called the **power** or **activity** of the force.

As before, we now extend this to the case where F and v are vectors in any two directions.

If a force F is moving a point with velocity v , then the rate at which it is doing work is equal to the scalar product Fv . If F is in pounds, and v in feet per second, the power Fv is given in foot-lbs. per second. This is a scalar quantity having no direction.

153. Commutative Law.—Since $\cos \theta = \cos (-\theta)$, it does not matter whether the angle θ in the scalar product is measured from a to b , or from b to a ; *i.e.* we get the same result by taking $\theta = \text{AOB}$ as by taking $\theta = \text{BOA}$ in Fig. 131, or $ab = ab \cos \theta = ba \cos (-\theta) = ba$.

Thus, in finding the scalar product of two vectors, the order of multiplication does not affect the result. In this respect scalar products resemble ordinary arithmetical products. This is the *commutative law* for scalar products.

154. Perpendicular and Parallel Vectors.—If the vectors a and b are at right angles $\theta = 90^\circ$, and $ab = ab \cos 90^\circ = 0$.

Thus, the scalar product of two perpendicular vectors is zero.

E.g. if the force F and the displacement s of its point of application are at right angles, the work done $= Fs = Fs \cos 90^\circ = 0$.

If the two vectors have the same direction, $\theta = 0$, and the scalar product $ab = ab \cos 0 = ab$, *i.e.* the scalar product is equal to the ordinary algebraical product.

E.g. if the force F produces a displacement s along its own direction, we know that the work done is the ordinary algebraical product Fs , and we now see that this is also the scalar product when the directions of the force and the displacement are the same. Thus the definition given above of the work done by a force as a scalar product is general, and includes as a special case the ordinary definition as the product of the force into the displacement in its own direction.

If a vector a be multiplied by itself the resulting scalar product is written a^2 . Since the angle $\theta = 0$,

$$a^2 = a \cdot a \cdot \cos 0 = a^2$$

or, the square of a vector is equal to the algebraical square of its numerical magnitude, and, being a scalar product, has, of course, no direction.

155. Rule of Signs.—The vector $-b$ is the vector b reversed.

The angle between a and $-b$ is the supplement of θ or $180^\circ - \theta$

$$\begin{aligned} \therefore \text{the scalar product } a(-b) &= ab \cos (180^\circ - \theta) \\ &= -ab \cos \theta = -ab \end{aligned}$$

$$\text{Similarly } (-a)(-b) = +ab$$

i.e. the rule of signs in scalar algebra also holds for scalar products of two vectors.

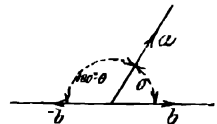

FIG. 132.

156. Consider two vectors a and b , both starting from the same point O in the same direction, and let a remain fixed while b rotates about O until it is in the opposite direction to a .

The numerical magnitudes a and b remain the same, so that the scalar product $ab \cos \theta$ follows the variations of $\cos \theta$.

The scalar product has its greatest value ab when a and b are in the same direction. As θ increases to a right angle the scalar product diminishes to 0.

As θ increases from a right angle to two right angles the scalar product is negative, and changes from 0 to $-ab$.

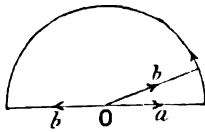

FIG. 133.

If b is made to rotate further the scalar product passes back through the same series of values to the value ab when b has turned through 360° .

We see that the scalar product of two vectors is a maximum when they are in the same direction, and a minimum when they are in opposite directions.

EXAMPLE (1).—Find the scalar product of the two vectors 12_{135° and 10_{100° .

Here $\theta = 55^\circ$ and the scalar product.

$$12_{135^\circ} \cdot 10_{100^\circ} = 10 \times 12 \times \cos 55^\circ \\ = 68.83$$

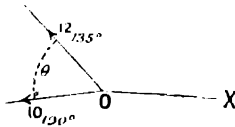

FIG. 134

EXAMPLE (2).—Calculate the scalar product of 6_{80° and 5_{230° .

Here $\theta = 150^\circ$ and the scalar product

$$6_{80^\circ} \cdot 5_{230^\circ} = 6 \times 5 \times \cos 150^\circ = -25.98$$

EXAMPLE (3).—A horse pulls a canal barge at the rate of $5\frac{1}{2}$ ft. per second with a force of 85 lbs. The rope makes an angle of 25° with the direction in which the barge is moving. Find the work done in pulling the boat 100 ft., and the horse-power.

The work done is given by the scalar product of a force vector of 85 lbs. along the direction of the rope, and a displacement vector of 100 ft. along the direction of motion of the boat.

$$\therefore \text{work done} = 85 \times 100 \times \cos 25^\circ \text{ ft.-lbs.} \\ = 7703 \text{ ft.-lbs.}$$

The power is equal to the scalar product of vectors of 85 lbs. and $5\frac{1}{2}$ ft. per second, making an angle of 25° with each other.

$$\therefore \text{Power} = 85 \times 5.5 \times \cos 25^\circ \text{ ft.-lbs. per second} \\ = \frac{85 \times 5.5 \times 0.9063}{55^\circ} \text{ H.P.} \\ = 0.770 \text{ H.P.}$$

EXAMPLES.—LXXXVI.

Calculate the following scalar products:—

- | | | | |
|---|--|---|--|
| 1. $5_{30^\circ} \cdot 1_0^\circ$. | 2. $5_{150^\circ} \cdot 1_0^\circ$. | 3. $5_{210^\circ} \cdot 1_0^\circ$. | 4. $5_{330^\circ} \cdot 1_0^\circ$. |
| 5. $5_{30^\circ} \cdot 1_{90^\circ}$. | 6. $5_{150^\circ} \cdot 1_{90^\circ}$. | 7. $5_{210^\circ} \cdot 1_{90^\circ}$. | 8. $5_{330^\circ} \cdot 1_{90^\circ}$. |
| 9. $5_{20^\circ} \cdot 3_{40^\circ}$. | 10. $3'1_{22^\circ} \cdot 2'3_{112^\circ}$. | 11. $(2'3_{202^\circ})^2$. | 12. $2'6_{22^\circ} \cdot 3'3_{213^\circ}$. |
| 13. $3'1'_{111^\circ} \cdot 4'2'_{203^\circ}$. | 14. $3'4'_{323^\circ} \cdot 2'9'_{39^\circ}$. | 15. $3'7'_{139^\circ} \cdot 2'5'_{229^\circ}$. | |
| 16. $4'3'_{323^\circ} \cdot 2'9'_{338^\circ}$. | 17. If $a = 5_{27^\circ}$; $b = 6_{30^\circ}$, find ab . | | |

18. Given $a = 2'5_{62^\circ}$; $b = 3'1_{141^\circ}$, calculate the value of ab . Also draw lines to represent the vectors $-a$ and $-b$, calculate the values of the scalar products

$$a(-b), (-a)b, (-a)(-b)$$

and verify that the rule of signs of ordinary algebraical multiplication also holds good for the scalar products of two vectors.

19. Find the scalar products of the following pairs of vectors in a horizontal plane: 15 N.W. and 10 E.; 12 S.E. and 15, 30° E. of N.; 350 S. and 7 W.; 12 in direction 25° N. of E.; and 13·1 in direction 16° N. of W.

20. A horse pulls a canal boat with a force of 364 lbs. If the rope makes an angle of 23° with the direction in which the boat moves, find the work done in pulling the boat 100 ft.

21. If the force in the last question is 500 lbs., and the boat moves with a velocity of 1 ft. per second; find the power. The angle between the rope and the direction of motion is 25°.

22. A truck is pulled at a speed of 8·8 ft. per second along a line of rails by a rope passed round a revolving drum at the side of the rails. If the angle between the rope and the direction of the rails is 28°, and the force in the rope is 512 lbs., find the power. What is the power when the truck is passing the drum, so that the rope is at right angles to the rails?

23. An electric tramcar is travelling at a speed of 14 $\frac{2}{3}$ ft. per second. The wind is blowing against the car at an angle of 40° to the track with a force of 155 lbs. Find the power exerted in overcoming the resistance of the wind.

24. *OB* is the crank, and *BA* the connecting-rod of an engine. *B* is moving round a circle at the rate of 6·3 ft. per second. *OB* = 6 ins., *BA* = 3 ft. Find the power at the instant when *OA* = 3·2 ft., and the thrust along *AB* is 1200 lbs.

157. Orthogonal Projection.

Let *OP* be any linear vector *r*, and *OX* a straight line in any other direction. Draw *PN* perpendicular to *OX*. Then *ON* is called the orthogonal projection of *OP* on *OX*, and the point *N* is called the projection of the point *P* on *OX*. In what follows we shall use the word projection to mean orthogonal projection.

If we regard *OP* as the displacement of a point, *ON* is the distance which the point moves in the direction *OX*, while it is displaced from *O* to *P*.

If *OP* is regarded as representing a velocity, acceleration or force, *ON* represents the component of that velocity, acceleration, or force in the direction *OX*.

Take a vector *OI* of unit length along *OX*. Let *i* denote this vector.

Then the scalar product of *OP* and *i* and $i \cdot r = r \cdot i = r \cdot \cos \text{NOP} = \text{ON}$.

∴ the orthogonal projection of a displacement vector *r* upon a direction *OX* is the scalar product of *r*, and a unit vector *i* in the direction *OX*.

The relation between the rectangular and polar coordinates of a point may now be expressed in the language of vector algebra.

Take rectangular axes *OX* and *OY* through *O*.

Let *x*, *y*, be the rectangular and *r*, *θ* the polar co-ordinates of *P*, and consider *r* as a vector in the direction *OP*.

Take unit vectors *OI* = *i* and *OJ* = *j* along *OX* and *OY*.

Then *x* and *y* are the projections of *r* on *OX* and *OY*.

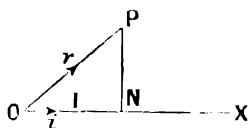

FIG. 136.

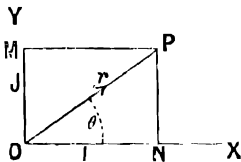

FIG. 137.

$$x = r \cdot i = r \cdot \text{I} \cdot \cos \text{XOP} = r \cos \theta$$

$$y = r \cdot j = r \cdot \text{I} \cdot \cos \text{POY} = r \cos (90^\circ - \theta) = r \sin \theta$$

Thus we may calculate *x* and *y* when *r* and *θ* are given.

EXAMPLE.—To find the projections of the vector 5₂₂₀ on the axes *OX* and *OY*.

In this and the following examples we shall take the base line *OX*, with reference

to which the directions of vectors are specified to be the same as the axis OX of rectangular ordinates.

If i and j are unit vectors along OX and OY (Fig. 137),

$$\begin{aligned} \text{Projection of } 5_{32^\circ} \text{ on } OX &= ON = 5 \cdot i = 5 \cdot 1 \cdot \cos 32^\circ = 4.24 \\ \text{,, } 5_{32^\circ} \text{ on } OY &= OM = 5 \cdot j = 5 \cdot 1 \cdot \cos 58^\circ = 2.6495 \end{aligned}$$

If the projections of a vector on two fixed straight lines are given, the vector is determined.

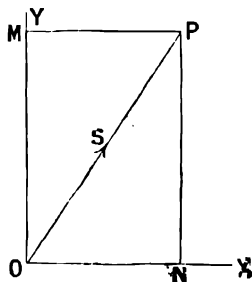

FIG. 138.

EXAMPLE.—The projections of a certain vector S on two fixed perpendicular straight lines OX and OY are 1.5 and 2.3. Find the numerical magnitude and the direction of S .

In the figure we have

$$ON = 1.5, \quad OM = 2.3 = NP$$

$$\therefore OP = \sqrt{1.5^2 + 2.3^2} = 2.745$$

$$\text{and } \tan NOP = \frac{2.3}{1.5} = 1.533 = \tan 57^\circ$$

$$\therefore NOP = 57^\circ$$

and S is the vector 2.745_{57° .

EXAMPLES.—LXXXVII.

Draw two axes OX and OY at right angles. Take OX as base line from which to measure the directions of the vectors. Find the projections of the following vectors on OX and OY :—

- | | | | | |
|-----------------------|-----------------------|-----------------------|-----------------------|------------------------|
| 1. 21_{23° . | 2. 21_{87° . | 3. 32_{43° . | 4. 19_{90° . | 5. 63_{102° . |
| 6. 63_{168° . | 7. 24_{213° . | 8. 37_{290° . | 9. 37_{310° . | 10. 29_{315° . |

Find the numerical magnitude and direction of the vector S in the following cases :—

	Projection of S on OX .	Projection of S on OY .
11.	2.7	1.1
12.	1.35	-2.74
13.	-3.46	2.95
14.	-4.7	-3.2
15.	4.5	-5.2

158. Resolution of Forces and Velocities.

EXAMPLE (1).—A boat is moving at the rate of 7 miles an hour in a direction $40^\circ E. of N.$ At what rates is it moving east and north?

If we take a straight line drawn from W. to E. as a base line, we have to find the projections of a vector 7_{50° on the directions OX and OY .

\therefore required velocity in direction E

$$= 7_{50^\circ} \times i = 7 \cos 50^\circ = 4.4996 \text{ miles per hour}$$

Velocity in direction N

$$= 7_{50^\circ} \times j = 7 \cos 40^\circ = 5.3620 \text{ miles per hour}$$

These velocities are called the rectangular components of the velocity 7_{50° in the directions E. and N.

EXAMPLE (2).—In Ex. 3, p. 290, find the component of the pulling force along the rope in the direction in which the boat is moving.

The magnitude of the required component force is the scalar product of a vector of 85 lbs. in the direction of the rope, and a unit vector making an angle of 25° with it,

$$= 85 \cdot 1 \cdot \cos 25^\circ = 77.03 \text{ lbs.}$$

Note that the work done in pulling the boat 100 ft. was found to be 7703 ft.-lbs.; i.e. it is the product of the displacement into the component of the force in the direction of the displacement.

EXAMPLES.—LXXXVIII.

In the following examples find the components of the given forces along **OX** and **OY**. The angle given in each case is the angle which the direction of the force makes with **OX**.

1. 35_{37° lbs. 2. 35_{135° lbs. 3. 35_{107° lbs. 4. 35_{213° lbs.

5. The components of a force along **OX** and **OY** are 35 lbs. and 24 lbs. Find the magnitude and direction of the force.

6. The components of a force are 156 lbs. in direction **N**. and 142 lbs. in direction **E**. Find the magnitude and direction of the force.

7. A truck weighing 7 tons is being pulled up a gradient of 1 in 35. What is the component of its weight which tends to pull it down the track?

8. A ship is sailing in direction **N.E.** at 15 miles an hour. How many miles per hour is it travelling in a direction due **E**?

9. A truck is running at 28 ft. per second down a gradient of 1 in 56. At what rate in feet per second is it moving vertically downwards?

10. A projectile is fired from a gun at a speed of 1800 ft. per second in a direction making an angle of 15° with the horizontal. Find its horizontal and vertical velocities.

11. A truck is drawn along a line of rails by means of a rope passing round a revolving drum at the side of the line. If the rope makes an angle of 17° with the rails, what must be the pull along the rope in order to give a force of 500 lbs. in the direction of the rails?

159. Projections of the Sides of a Closed Polygon.

Let **OABCDE** be any closed polygon. Consider the sides **OA**, **AB**, **BC**,

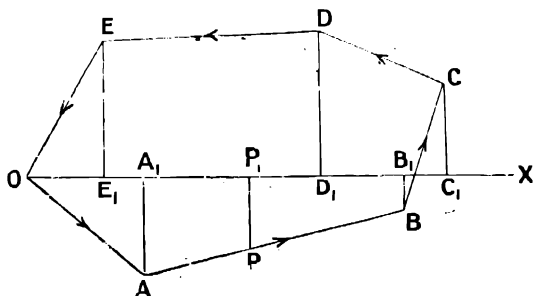

FIG. 139.

CD, **DE**, **EO** as vectors, whose directions all pass the same way round the figure.

Then the sum of the projections on any straight line **OX** of **OA**, **AB**, etc., taken with their proper signs is zero.

For, let A_1, B_1, C_1, \dots be the projections of **A**, **B**, **C** . . . and consider

the vectors $OA, AB, BC \dots$ as the displacements of a point P as it moves round the figure. Then, as the point P moves through A, B, C , etc., in succession, its projection P_1 moves through A_1, B_1, C_1 , etc. When the moving point P comes back to O its projection P_1 also comes back to O , and the total displacement of P_1 along OX has been zero.

I.e. the sum of the projections of $OA, AB, BC \dots$ on OX is zero.

The same reasoning applies if the projections are taken on a line which does not pass through an angular point of the polygon.

The vectors $OA, AB, BC \dots$ above need not be supposed actually to form a polygon. It is sufficient that their magnitudes and directions are such that they could be moved parallel to themselves, so as to form a closed polygon, *i.e.* their sum must be zero whatever their positions.

We may state the above theorem as follows:—

If the sum of a number of linear vectors is zero, the sum of their projections on any line is zero.

If the vectors OA, AB, BC , etc., represent forces acting at a point, they are in equilibrium since their vector sum, which is equal to their resultant, is zero. Thus the theorem of this paragraph leads to the important theorem in mechanics that the sum of the components in any direction of a system of forces in equilibrium is zero.

180. Distributive Law for Scalar Products.

Next consider a number of vectors OA, AB, BC, CD, DE whose sum is OE .

As before, whilst a point P passes from O to E , along the vectors OA, AB, BC, CD, DE , its projection P_1 on OX passes through A_1, B_1, C_1, D_1, E_1 , and P_1 has altogether been displaced for a net distance OE_1 , which is the projection of OE .

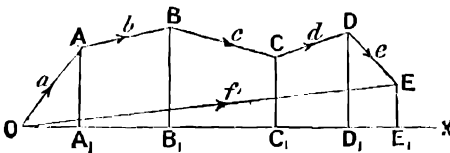

FIG. 140.

\therefore the sum of the projections of a number of vectors $OA, AB, \dots DE$ is

equal to the projection of their sum OE .

As before, this result holds good whatever the position of the vectors considered.

In the figure let a, b, c, d, e, f be the vectors OA, AB, BC, CD, DE, OE respectively.

We have $a + b + c + d + e = f$.

Then, if i be a unit vector along OX , the projection of any vector a on OX is the scalar product $i \cdot a$, and we have shown that the sum of the projections of a, b, c, d, e is equal to the projection of their sum f .

$$\therefore i(a + b + c + d + e) = if = ia + ib + ic + id + ie$$

Let p be a vector of any size along OX . Then, since i is of unit length, $pi = p$, and multiplying both sides of the above equation by p , we get

$$p(a + b + c + d + e) = pa + pb + pc + pd + pe$$

This is the Distributive Law for scalar products of two vectors. We have already pointed out that this law holds when the sum of a number of vectors is multiplied by a scalar quantity, we have now shown that it also holds when the sum of a number of vectors is multiplied by another vector so as to form a scalar product.

EXAMPLES.—LXXXIX.

1. If $a = 3_{40^\circ}$, $b = 5_{115^\circ}$, $c = 4_{71^\circ}$, find the vector sum $a + b$, and the scalar products $c(a + b)$, ca , and cb , and verify that $c(a + b) = ca + cb$.

2. Verify in the same way that $c(a - b) = ca - cb$ for the case when $a = 2'7_{11^\circ}$, $b = 3'1_{135^\circ}$, $c = 1'9_{205^\circ}$.

161. Calculation of the Sum of a Number of Vectors.—The distributive law for scalar products gives a method of calculating the sum of any number of vectors.

Let the vector S be the sum of the vectors a, b, c, d . We have

$$a + b + c + d = S$$

Taking unit vectors i and j along the axes of x and y , we have by the distributive law

$$ai + bi + ci + di = Si$$

Or, in words, the projection of S on the axis of x is equal to the sum of the projections a, b, c , and d on the axis of x .

So also

$$aj + bj + cj + dj = Sj$$

Or, the projection of S on the axis of y is equal to the sum of the projections of a, b, c , and d on the axis of y .

We thus calculate the projections of the required vector sum on the two axes.

The numerical magnitude of S is equal to the square root of the sum of the squares of Si and Sj . Also the tangent of the angle which S makes with $OX = \frac{Sj}{Si}$, and thus the direction of S is found.

EXAMPLE.—Let $a = 3_{62^\circ}$, $b = 4_{165^\circ}$, $c = 2_{280^\circ}$. Calculate the value of the vector sum $S = a + b + c$.

Take the base line from which the given angles are measured as the axis of x , and a straight line OY perpendicular to it as the axis of y .

Then we have seen that the sum of the projections of a, b, c on OX is equal to the projection of S on OX ; *i.e.* in the figure, $OA_1 + A_1B_1 + B_1C_1 = OC_1$, each projection being taken with its proper sign.

Therefore, if i be a unit vector in the direction OX ,

sum of projections of a, b , and c on OX

$$\begin{aligned} &= ai + bi + ci = 3 \cos 62^\circ + 4 \cos 165^\circ \\ &\quad + 2 \cos 280^\circ \\ &= 3 \times 0.4695 - 4 \times 0.9659 + 2 \times 0.1736 \\ &= -2.1079 = \text{projection of } S \text{ on } OX \\ &= Si = OC_1 \end{aligned}$$

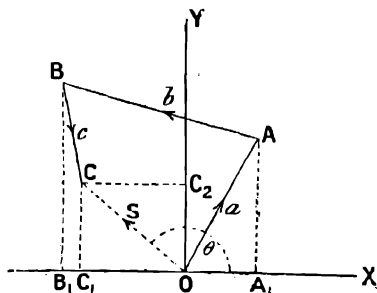

FIG. 142.

Similarly, if j is a unit vector in direction OY ,

sum of projections of a, b , and c on OY

$$\begin{aligned} &= aj + bj + cj = 3 \sin 62^\circ + 4 \sin 165^\circ + 2 \sin 280^\circ \\ &= 3 \times 0.8829 + 4 \times 0.2588 - 2 \times 0.9848 \\ &= 1.7143 = \text{projection of } S \text{ on } OY = Sj = OC_2 \end{aligned}$$

$$\begin{aligned}\therefore S^2 &= OC_1^2 + C_1C_2^2 = (Si)^2 + (Sj)^2 \\ &= (-2\cdot108)^2 + (1\cdot714)^2 = 7\cdot38 \\ \therefore S &= \sqrt{7\cdot38} = 2\cdot717\end{aligned}$$

To find the direction of S , we have, if θ be the angle which S makes with OX ,

$$\begin{aligned}\tan \theta &= \frac{C_1C_2}{OC_1} = \frac{Sj}{Si} = -\frac{1\cdot714}{2\cdot108} = -0\cdot814 = -\tan 39^\circ \\ \therefore \theta &= (180^\circ - 39^\circ) = 141^\circ \\ \therefore S &= 2\cdot717_{141^\circ}\end{aligned}$$

The student should compare this value of S with the value obtained by construction and measurement.

Similarly, to calculate the value of $S = a - b + c$, we find the values of $ai - bi + ci$ and $aj - bj + cj$, which are the projections of S on the axes, and thus the value of S may be calculated.

The same method may, of course, be used when the vectors are forces, in order to find their resultant.

EXAMPLES.—XC.

Work Examples LXXXI., Nos. 1 to θ , by calculation, and compare with the results previously obtained by construction.

11. The following forces act at a point O :—

$$530^\circ, 703^\circ, 3140^\circ, 5225^\circ, 4200^\circ.$$

The magnitude of each force is given in pounds, and the given angles are the angles which the respective forces make with a straight line OX . Find the magnitude and direction of the resultant of the given forces both by calculation and construction.

12. The following forces act at a point. Find their resultant by calculation and construction.

$$681^\circ, 8100^\circ, 3170^\circ, 4200^\circ, 9240^\circ.$$

13. $AB, BC, CD \dots$ are straight passages, called drifts, in a mine in the same horizontal plane. Their lengths and the angles which they make, with a straight line running from S . to N ., are measured as follows :—

Drift.	Length (links).	Angle with meridian.
AB	265	180°
BC	128	92°
CD	104	142°
DE	71	$67\cdot5^\circ$
EF	292	156°
FG	633	260°

What would be the length and direction of a drift bored from B to G ? Work both by calculation and construction, and compare results.

14. With the same data as in the last example, it is required to bore from some point in the drift FG a drift which shall come out at B , and be in the same straight line with BA . Calculate the distance from F of the point from which the new boring must start, the angle between the new boring and FG , and the length of the new boring. Verify by construction.

NOTE.—If K be the required point on FG , the sum of the projections of BC, CD, DE, EF, FK , on an axis at right angles to AB is zero.

15. A drift is to be bored from D to G . What is its length, and what angle does it make with CD ?

162. **Centre of Gravity of a Number of Particles.**—The distributive law gives a proof of the method of finding the rectangular co-ordinates of

the centre of gravity of a number of weights at points whose co-ordinates are known.

It was proved in p. 286 that if G is the centre of gravity of weights m_1 at P_1 , m_2 at P_2 , m_3 at P_3 . . . and O is any point, then, in the notation of vector algebra,

$$(m_1 + m_2 + m_3 + \dots) \mathbf{OG} = m_1 \mathbf{OP}_1 + m_2 \mathbf{OP}_2 + m_3 \mathbf{OP}_3 + \dots$$

Take two rectangular axes \mathbf{OX} and \mathbf{OY} . Let (x_1, y_1) , (x_2, y_2) . . . be the co-ordinates of P_1, P_2, \dots and let (\bar{x}, \bar{y}) be the co-ordinates of G .

Form the scalar product of each side of the above equation with the unit vector i along \mathbf{OX} .

Then, by the distributive law,

$$(m_1 + m_2 + m_3 + \dots) \mathbf{OG}i = m_1 \cdot \mathbf{OP}_1 \cdot i + m_2 \cdot \mathbf{OP}_2 \cdot i + m_3 \cdot \mathbf{OP}_3 \cdot i + \dots$$

But $\mathbf{OG} \cdot i = \bar{x}$; $\mathbf{OP}_1 i = x_1$; $\mathbf{OP}_2 i = x_2$. . .

$$\therefore (m_1 + m_2 + m_3 + \dots) \bar{x} = m_1 x_1 + m_2 x_2 + m_3 x_3 + \dots$$

Or, as it is usually written,

$$\bar{x} = \frac{\Sigma(mx)}{\Sigma(m)}$$

where $\Sigma(mx)$ denotes the sum of all the terms of the form mx .

Similarly, by multiplying by a unit vector j along \mathbf{OY} , we get

$$\bar{y} = \frac{\Sigma(my)}{\Sigma(m)}$$

EXAMPLE.—Find the co-ordinates of the centre of gravity of the following weights: 1 lb. at the point (1, 2.5); 2 lbs. at (0.5, 1); 3 lbs. at (1.6, 1.5); 4 lbs. at (1.9, 0.5); 6 lbs. at (2.5, 2.5); 3 lbs. at (3.2, 1.9).

We have

$$\begin{aligned} \bar{x} &= \frac{\Sigma(mx)}{\Sigma(m)} = \frac{(1 \times 1) + (2 \times 0.5) + (3 \times 1.6) + (4 \times 1.9) + (6 \times 2.5) + (3 \times 3.2)}{1 + 2 + 3 + 4 + 6 + 3} \\ &= \frac{39.0}{19} = 2.053 \end{aligned}$$

Similarly

$$\begin{aligned} \bar{y} &= \frac{\Sigma(my)}{\Sigma(m)} = \frac{(1 \times 2.5) + (2 \times 1) + (3 \times 1.5) + (4 \times 0.5) + (6 \times 2.5) + (3 \times 1.9)}{1 + 2 + 3 + 4 + 6 + 3} \\ &= \frac{31.7}{19} = 1.67 \end{aligned}$$

\therefore the centre of gravity is a point G whose co-ordinates are (2.053, 1.67).

EXAMPLE.—Find and show in a figure the position of the centre of gravity of the following weights at the points given by the corresponding values of x and y .

Weights	4	3	6	2	3
x	2	4.2	2.5	1.2	3
y	3.5	2.3	4.5	3.1	2

$$\text{Answer } \bar{x} = 2.61.$$

$$\bar{y} = 3.34.$$

163. Principles of Virtual Work and Virtual Velocity.—If the vectors a, b, c, d, e are forces acting at a point, and a displacement p is given to their point of application, while their directions remain unchanged, the scalar products in the equation

$$pa + pb + pc + pd + pe = p(a + b + c + d + e) = pf$$

give the work done by each force and by the resultant f , and the distributive law expresses the theorem that the sum of the work done by all the forces is equal to the work done by their resultant.

If the forces are in equilibrium their resultant is zero, and the sum of the work done by all the forces is zero.

This is the principle of **Virtual Work** in mechanics.

Similarly, if p is the velocity of the point of application of the forces, the scalar products are the powers, or rates of doing work of the respective forces and of their resultant.

The distributive law then expresses that if the point of application of the forces be supposed to have any velocity, the sum of the powers of the various forces is equal to the power of their resultant. Or, if they are in equilibrium, the sum of their powers is zero. This is the principle of **Virtual Velocities** in mechanics.

164. Use of Brackets.—We may now extend the distributive law to the multiplication of two expressions in brackets.

Consider the scalar product

$$(a + b)(c + d)$$

$(a + b)$ denotes a single vector, which is the vector sum of a and b .

∴ by the distributive law, as shown in § 160,

$$(a + b)(c + d) = (a + b)c + (a + b)d$$

We now get the sum of two separate products $(a + b)c$ and $(a + b)d$, and, applying the distributive law to each of these, we get

$$(a + b)(c + d) = ac + bc + ad + bd$$

This may be extended to the scalar product of two brackets containing any number of terms connected by plus or minus signs, since, for any vector having a minus sign, we may substitute a positive vector in the opposite direction.

We have previously shown that the commutative law $ab = ba$ holds good for the scalar products of two vectors. Since each bracket denotes a single vector, this law also holds good for the scalar product of two brackets containing vectors connected by the plus or minus signs.

All the operations of ordinary scalar algebra involving the use of brackets and the multiplication of not more than two quantities, can be shown to depend on these two laws, the distributive law and the commutative law.

It follows that we may proceed with the scalar products of two vector expressions of the first degree, exactly as with products of two scalar quantities in ordinary algebra. *E.g.* the result

$$(a + b)^2 = a^2 + 2ab + b^2$$

holds good when a and b are vectors; $a + b$ means their vector sum, ab means the scalar product of a and b , and the squares as shown in § 154 are the squares of the numerical magnitudes of the vectors $a + b$, a , and b : for the proof of this result in ordinary scalar algebra only depends on the distributive law, and therefore holds equally well for vector algebra.

EXAMPLE.—To prove that the sum of the squares on the two sides containing the right angle of a right-angled triangle is equal to the square on the hypotenuse.

Let BC , CA be two vectors a and b at right angles, and let the vector $BA = c$. Then, by vector addition, $c = a + b$.

Squaring, we get

$$c^2 = a^2 + 2ab + b^2$$

or, since $a^2 = a^2$, $b^2 = b^2$, $ab = ab \cos \text{BCA}$, $c^2 = c^2$

$$\begin{aligned} c^2 &= a^2 + 2ab \cos 90^\circ + b^2 \\ &= a^2 + b^2 \end{aligned}$$

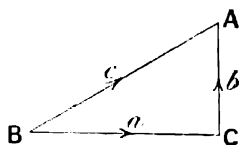

FIG. 142.

i.e. the sum of the squares on BC and CA is equal to the square on AB .

105. General Proof of the Formula

$$\cos(\theta_1 - \theta_2) = \cos \theta_1 \cos \theta_2 + \sin \theta_1 \sin \theta_2$$

This formula has already been proved in Chapter IV., for the case where θ_1 and θ_2 are acute angles. We can now prove it for the case when θ_1 and θ_2 are angles of any magnitude.

Take two points, P_1 and P_2 , whose polar co-ordinates are (r_1, θ_1) and (r_2, θ_2) . Let (x_1, y_1) and (x_2, y_2) be the rectangular co-ordinates of P_1 and P_2 .

Regard x_1, y_1, r_1 as vectors in directions ON_1, N_1P_1, OP_1 , so that by vector addition

$$r_1 = x_1 + y_1$$

and similarly

$$r_2 = x_2 + y_2$$

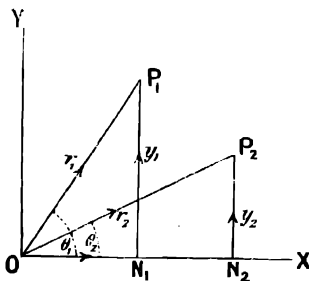

FIG. 143.

Forming the scalar product of r_1 and

r_2 , we get

$$\begin{aligned} r_1 r_2 &= (x_1 + y_1)(x_2 + y_2) \\ &= x_1 x_2 + x_1 y_2 + y_1 x_2 + y_1 y_2 \end{aligned}$$

by the distributive law,

$$= x_1 x_2 + y_1 y_2$$

since the scalar product of two perpendicular vectors is zero.

∴ putting in the values of the scalar products, we get

$$\begin{aligned} r_1 r_2 \cos \text{P}_2 \text{OP}_1 &= x_1 x_2 \cos 0^\circ + y_1 y_2 \cos 0^\circ \\ r_1 r_2 \cos(\theta_1 - \theta_2) &= x_1 x_2 + y_1 y_2 \end{aligned}$$

$$\begin{aligned} \therefore \cos(\theta_1 - \theta_2) &= \frac{x_1}{r_1} \cdot \frac{x_2}{r_2} + \frac{y_1}{r_1} \cdot \frac{y_2}{r_2} \\ &= \cos \theta_1 \cos \theta_2 + \sin \theta_1 \sin \theta_2 \end{aligned}$$

This proof holds for any values of θ_1 and θ_2 . We may therefore write $-\theta_2$ for θ_2 , and we get

$$\cos(\theta_1 + \theta_2) = \cos \theta_1 \cos \theta_2 - \sin \theta_1 \sin \theta_2$$

By changing θ_1 to $\theta_1 + \frac{\pi}{2}$, we get, since

$$\cos\left(\theta_1 + \theta_2 + \frac{\pi}{2}\right) = -\sin(\theta_1 + \theta_2)$$

$$\cos\left(\theta_1 + \frac{\pi}{2}\right) = -\sin \theta_1, \quad \sin\left(\theta_1 + \frac{\pi}{2}\right) = \cos \theta_1$$

$$\therefore \sin(\theta_1 + \theta_2) = \sin \theta_1 \cos \theta_2 + \cos \theta_1 \sin \theta_2$$

and, changing the sign of θ_2 , we get

$$\sin(\theta_1 - \theta_2) = \sin \theta_1 \cos \theta_2 - \cos \theta_1 \sin \theta_2$$

EXAMPLES.—XCI.

1. Prove the formula in trigonometry,

$$a^2 = b^2 + c^2 - 2bc \cos A$$

by vector algebra.

2. If \mathbf{R} is the resultant of two forces, \mathbf{P} and \mathbf{Q} , acting at a point so that θ is the angle between \mathbf{P} and \mathbf{Q} , prove that

$$R^2 = P^2 + Q^2 + 2PQ \cos \theta.$$

3. \mathbf{ABC} is a triangle, and \mathbf{D} is the mid point of \mathbf{BC} . Prove that

$$\mathbf{AB}^2 + \mathbf{AC}^2 = 2\mathbf{AD}^2 + 2\mathbf{DB}^2.$$

4. With the same figure as in question 3, prove that

$$\mathbf{AD}^2 - \mathbf{DC}^2 = \mathbf{AB} \cdot \mathbf{AC} \cos A.$$

5. Prove that the sum of the squares of the distances of the two ends of a diameter of a given sphere from a given point is the same whatever diameter be taken.

6. Explain the physical meaning of the commutative law for scalar products when the two vectors are a force and a displacement respectively.

7. a, b, c , and d are the sides of a quadrilateral, none of whose angles are greater than 180° . α and β are the angles between a, b and b, c respectively; γ is the angle between a and c when they are produced to meet. α, β , and γ are taken as the angles which face towards d at each point of intersection. Prove that

$$d^2 = a^2 + b^2 + c^2 - 2ab \cos \alpha - 2bc \cos \beta - 2ca \cos \gamma.$$

106. Field of a Vector.—This section is chiefly intended for students of electricity.

Consider the case of a stream of water in steady motion. At every point in the interior of the stream the velocity of the water is a vector having a definite magnitude and direction.

If any vector satisfies this condition throughout any region of space, that region is called the **field** of the vector. In the above example the region of space occupied by the stream is the field of the velocity of the water regarded as a vector.

Consider any limited space on the earth's surface, such as the interior of a room.

The weight of a given mass is a vector, which has the same magnitude and direction at every point in the room. The interior of the room is, therefore, the field of a vector, and when, as in this case, the vector is the same at every point, the field is called a **uniform field**.

At every point in the space near the poles of a magnet the magnetic force is a vector which has a definite value, and changes continuously as we pass from point to point. This space may, therefore, be regarded as the field of the magnetic force, and is usually spoken of as a **magnetic field**.

The conception of a magnetic field is of great importance in electricity.

It is usual to represent the direction of the magnetic force vector by lines, called **lines of force**, supposed to pass through the field so that at every point their direction is the same as that of the force.

The magnitude of the force is represented by the number of lines which cross a square centimetre of a surface at right angles to the direction of the field. Thus in air we may have 8000 lines to the square centimetre, and in iron 18,000 lines of induction per square centimetre.

187. Flow or Flux of a Vector across a Surface.—Consider the case of a stream flowing with uniform velocity v feet per second at every point, and suppose a plane surface is drawn in the fluid, making an angle θ with the direction of flow. Then we may require to find the amount of fluid which flows across a unit area of the surface in one second.

Let $ABCD$ be a square of one foot side perpendicular to the direction of flow, and having the side AB in the given surface. Let the lines of flow through C and D meet the given surface in E and F , and complete the rectangle $ABEF$.

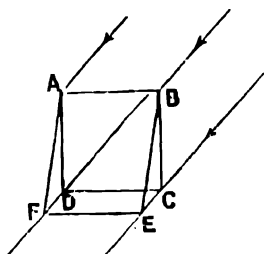

FIG. 144.

$$\text{Then } \angle BEC = \theta \text{ and } BE = \frac{BC}{\sin \theta} = \frac{1}{\sin \theta} \text{ ft.}$$

$$\therefore \text{area } ABEF = AB \cdot BE = \frac{1}{\sin \theta} \text{ sq. ft.}$$

Now, since $ABCD$ is one square foot in area, and the fluid flows through this square at the rate of v feet per second, it follows that v cubic feet of the fluid flow through $ABCD$, and therefore through $ABEF$, in one second.

Therefore the volume of the fluid flowing through one square foot of the surface in each second is

$$\frac{v}{\sin \theta} = v \sin \theta \text{ cu. ft.}$$

$\sin \theta$ is the cosine of the angle between the vector v and a unit normal n drawn from the surface $ABEF$ on that side to which the stream is flowing, and thus we may also state the above result as follows:—

The volume of fluid flowing through one square foot of the surface in each second is equal to the scalar product of the vector v and a unit normal drawn from the surface on the side to which the stream is flowing.

For example, in a stream flowing uniformly at 10 ft. per second, the flow per square foot across a surface making an angle of 40° with the stream lines is

$$10 \sin 40^\circ = 6.428 \text{ cu. ft. per second}$$

Similarly, we may say that in any vector field the flow or flux of the vector across unit area of a surface is the scalar product of the vector and a unit normal drawn from the surface on the side to which the vector passes. An important example of this occurs in the case of the magnetic field where the flow of the magnetic induction vector across a surface in the field is spoken of as the magnetic flux per unit area across that surface.

EXAMPLE.—In a magnetic field of 6000 lines per square centimetre, to find the flux per square centimetre across a surface making an angle of 35° with the field.

Here the angle between the normal and the field is 55° , and therefore the flux across the surface is $6000 \times 1 \times \cos 55^\circ = 3442$ lines per sq. cm.

EXAMPLES.—XCII.

1. If the intensity of a magnetic field in air is 8000 lines per square centimetre, find the flux across surfaces inclined at angles of (a) 85° , (b) 45° , (c) 5° , to the direction of the field.

2. The intensity of a magnetic field in iron is 18,000 lines of induction per square centimetre. Find the flux per square centimetre across surfaces inclined at angles of (a) 77° , (b) 61° , (c) 43° , (d) 2° , to the field.

3. Find the flux per square centimetre across a surface inclined at an angle of 61° to the direction of a field of 12,400 lines per square centimetre.

4. 0.525 inches of rain fell on a certain day. How many cubic feet of water fell on a roof 252 sq. yds. in area, and inclined at an angle of 40° to the vertical? The rain is supposed to fall vertically.

NOTE.—The expression "one inch of rain" means that if the rain which falls on a horizontal surface is not allowed to escape, it will cover the surface to a depth of one inch.

5. A stream is flowing at 7.3 miles per hour. Find the flow per square foot per hour across a surface making an angle of 30° with the stream.

6. A valley runs east and west, and its sides have a mean slope of 20° to the horizontal. Compare the quantities of sunshine received per square yard by the two sides of the valley when the sun is due south at an elevation of 70° .

168. Vector Products.

Definition.—The vector product of two vectors a and b is a vector c , whose numerical magnitude is $ab \sin \theta$, where θ is the angle included between a and b . Its direction is perpendicular to the plane of a and b , and is such that to a person facing in the direction of c a clockwise rotation passes from a to b .

The vector product is written Vab .

We may state the direction in another way, by saying that if the angle θ is always measured from a to b in a counter-clockwise direction, then a positive value of the vector product $ab \sin \theta$ indicates that it is directed towards the spectator; a negative value, that it is directed from the spectator.

The rule for direction is most easily remembered by imagining that an ordinary right-handed screw is being turned from a to b in the direction in which θ is measured. Then the screw will move forward in the direction of the vector product c

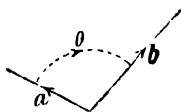

FIG. 145.

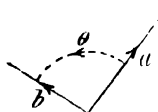

FIG. 146.

E.g., in Fig. 145, if a right-handed screw is turned from a to b it will pass down into the paper, and accordingly the direction of the vector product Vab is down into the paper and perpendicular to it.

In Fig. 146, if a right-handed screw is turned from a to b it will move forward from the paper towards the spectator, and, therefore, the direction of Vab is towards the spectator.

169. Geometrical Representation of the Vector Product.—Let a

and b be two displacement vectors, and construct a parallelogram of which they are two adjacent sides. Then $ab \sin \theta$ is equal to the area of this parallelogram. We may thus obtain a way of looking at the vector multiplication of two vectors as a process in the geometry of motion.

We may say that, to form the vector product Vab of a multiplied by b , we move the vector a parallel to itself through a displacement equal to the vector b . Then draw a line at right angles to the plane of the parallelogram thus traced out, in the direction given by the above rule, and mark off along it a length numerically equal to the area of the parallelogram. Then this line of definite length is the vector product of a and b .

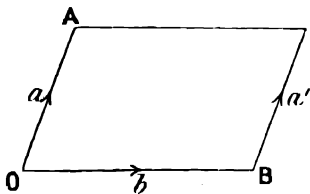

FIG. 147.

Students familiar with the working of Amsler's planimeter will note that if a is the free arm carrying the roller, the instrument registers the numerical magnitude of the total vector product of the length of the arm a regarded as a vector, and the vector displacement of the tracing point.

It can be shown that areas swept out by rotation of the free arm cancel each other in passing round a closed curve, and that the area enclosed in the curve is equal to the total vector product as registered by the rolling wheel.

We may now express the rule for the direction of the vector product in another way. If the paper is held facing the observer, so that a points upwards, then, if a is moved to the right through the displacement b , the vector product Vab is directed away from the observer; while, if a is moved to the left, Vab is directed towards the observer.

170. Commutative Law.—In multiplying two numbers together it does not matter which we take first, *i.e.* $ab = ba$, and we have shown that the same law is true of scalar products. Vector products, however, do not obey this commutative law.

In the figure, the direction of the vector product Vab is found by imagining that a right-handed screw is turned from a to b . It will pass down into the paper so that the direction of Vab is away from the observer.

To find the direction of Vba we suppose a right-handed screw to turn in the opposite direction from b to a ; in this case it will move up through the paper towards the observer. Thus the direction of Vba is opposite to that of Vab .

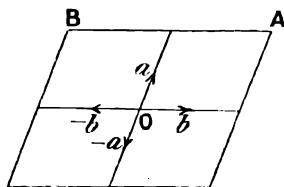

FIG. 148.

The two products Vba and Vab have the same numerical magnitude $ab \sin \theta = ba \sin \theta$.

$\therefore Vab$ and Vba are equal in numerical magnitude, but opposite in direction or sign.

We get the law

$$Vab = -Vba$$

This is an important difference between vector products and scalar products, which, as we have seen, satisfy the corresponding law

$$ab = ba$$

We get the same result by taking into account the direction in which θ is measured in calculating the magnitude of the vector product, for, if $ab \sin \theta$

is positive when θ is measured from a to b , it will be negative when θ is measured from b to a , *i.e.* when the sign of θ is changed.

171. Rule of Signs.—Vector products obey the same rule of signs as the products of scalar quantities.

For consider the effects of a change of sign in a or b , or both, on the vector product Vab . (Fig. 148.)

If a screw passes downwards when turned from a to b at O , it will pass upwards when turned from a to $-b$,

$$\therefore V(ab) = -V(a, -b)$$

So also, if turned from $-a$ to $-b$ at O , the screw will move forwards in the same direction as when turned from a to b .

$$\therefore Vab = V(-a, -b)$$

Thus the "rule of signs" of ordinary scalar algebra also applies to vector products.

The working of an Amsler's planimeter affords an illustration of the rule of signs as applied to vector products. The wheel registers positive vector products by rolling one way, and negative vector products by rolling the opposite way, thus automatically adding the products up with their proper signs. The student who is accustomed to use a planimeter is probably familiar with the fact that if the tracing point is taken the wrong way round the area to be measured, the result is measured backwards from the zero point, *i.e.* with a negative sign.

EXAMPLE (1).—Find the vector products $V(3_{46^\circ} \cdot 5_{122^\circ})$ and $V(6_{232^\circ} \cdot 5_{100^\circ})$.

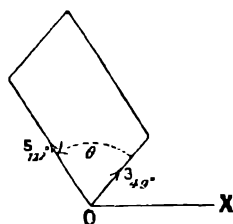

FIG. 149.

The angle θ between 3_{46° and 5_{122° is 73° .

$$\therefore V(3_{10^\circ} \cdot 5_{122^\circ}) = 3 \times 5 \times \sin 73^\circ = 14'34$$

in a direction perpendicular to the plane of the paper, and towards the observer.

Similarly $V(5_{122^\circ} \cdot 3_{46^\circ})$ is a vector $14'34$ directed away from the spectator.

The angle between 6_{232° and 5_{100° is 152° .

$$\therefore V(6_{232^\circ} \cdot 5_{100^\circ}) = 6 \times 5 \times \sin 152^\circ = 14'08_5$$

in a direction away from the observer.

172. Magnetic Field.

EXAMPLE (2).—If a straight conductor, carrying a current of C amperes, is placed in a uniform magnetic field of intensity B lines per square centimetre, it experiences a force of F dynes per unit length. The value and direction of F are given by the equation

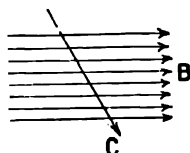

FIG. 150.

$$F = \frac{1}{10} V(CB)$$

Note that F , C , and B are vectors.

Find the force experienced by a straight wire, carrying a current of 3 amps., in a field of intensity 5000 lines per square centimetre. The direction of the current makes an angle of 60° with the magnetic field.

$$\begin{aligned} \text{We have } F &= \frac{1}{10} V(CB) \\ &= \frac{1}{10} \cdot 3 \cdot 5000 \cdot \sin 60^\circ = 1300 \text{ dynes} \end{aligned}$$

∴ the wire experiences a force of 1300 dynes per centimetre of its length in a direction perpendicular to the plane of *C* and *B*, and towards the observer if the directions of *C* and *B* are as shown in Fig. 150.

EXAMPLE (3).—If a straight conductor be moved through a magnetic field of intensity *B* lines per square centimetre, with a velocity *q* cm. per second, an E.M.F. of *E* volts. per unit length will be induced. The value and direction of *E* are given by the equation

$$E = V(q \cdot B) \cdot 10^{-8} \text{ volts.}$$

E, *q*, and *B* are vectors.

A straight wire in the armature of a dynamo is being moved at right angles to itself with a velocity of 2400 cms. per second through a magnetic field of 6000 lines per square centimetre. The direction of the wire is at right angles to the field and to the motion. Find the E.M.F. induced in the wire.

$$\begin{aligned} E &= 10^{-8} \cdot V \cdot (qB) = \frac{2400 \cdot 6000 \cdot \sin 90^\circ}{10^8} \\ &= 0.144 \text{ volt. per cm. length} \end{aligned}$$

If the wire is supposed to be perpendicular to the plane of the paper, and to be moved in the direction of the arrow, the induced E.M.F. is directed from the observer.

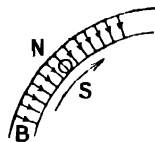

FIG. 151

EXAMPLES.—XCIII.

Find the following vector products ; specify the direction of each by reference to a figure.

- | | | |
|--|---------------------------------------|--|
| 1. $V_{527^\circ} \cdot 639^\circ$. | 2. $V_{558^\circ} \cdot 7134^\circ$. | 3. $V_{6120^\circ} \cdot 7230^\circ$. |
| 4. $V_{7250^\circ} \cdot 6120^\circ$. | 5. $V_{350^\circ} \cdot 487^\circ$. | 6. $V(350^\circ)(-487^\circ)$. |
| 7. $V(-350^\circ)(-487^\circ)$. | 8. $V(-350^\circ)(487^\circ)$. | |

9. A wire is moved with a velocity of 1320 cms. per second at right angles to its length, across a magnetic field of 5000 lines per square centimetre, in a direction making an angle of 81° with the direction of the field. What E.M.F. will be developed per unit length of the wire? Explain its direction by means of a figure.

10. Find the force on a wire carrying a current of 4 amps. in a magnetic field of intensity 5525 lines per square centimetre, the current making an angle of 65° with the direction of the field. If the direction of the field be taken from left to right, and the angle 65° as being measured in a counter-clockwise direction from the field to the current, state the direction of the force.

173. Distributive Law.—To prove that vector products satisfy the equation

$$Va(b + c) = Vab + Vac$$

where the sign + of course denotes vector addition.

We shall here confine ourselves to the case where *a*, *b*, and *c* are in the same plane.

In the figure let *AB* = *a*, *AC* = *b*, and *CD* = *c*.

Then *AD* = *b* + *c*.

We shall consider the vector products as the result of a geometrical process, as explained in § 169.

1. Let *b* and *c* be both directed to the same side of *a*, as in Fig. 152.

To form *Va(b + c)* we move *AB* parallel to itself along *AD*, thus tracing out the parallelogram *ABED*. Similarly *Vab* is given by the area *ABFC*.

And, since $CF = a$, Vac is given by the area $CFED$.

And since the three parallelograms, AF , CE , and AE , have equal bases, and the sum of the heights of AF and CE is equal to the height of AE , it follows by elementary geometry that

$$ABED = ABFC + CFED$$

i.e. the vector a traces out the same area if moved through the displacements b and c in succession, as it does if moved through the displacement $b + c$.

Since, in the figure, the three vector products which occur are all directed towards the observer, and perpendicular to the plane of the paper, Vab and

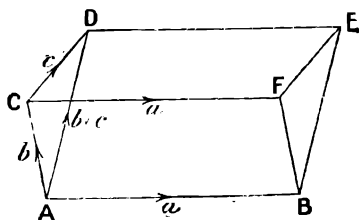

FIG. 152.

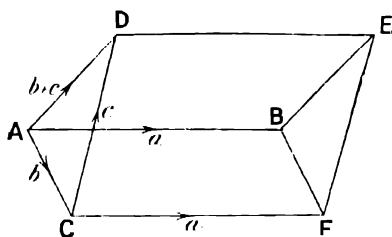

FIG. 153.

Vac are both in the same direction, and their sum may be found by adding the areas of the corresponding parallelograms by ordinary arithmetical addition,

$$\therefore Va(b + c) = Vab + Vac$$

II. Let b and c be directed to opposite sides of a , as in Fig. 153.

Then the vector a traces out the same area if it is moved parallel to itself through the displacements CA and AD in succession, as it does if it receives the displacement CD .

$$\therefore V(a)(-b) + Va(b + c) = Vac$$

but by the rule of signs for vector products, § 171,

$$\begin{aligned} V(a)(-b) &= -Vab \\ \therefore Va(b + c) &= Vab + Vac \end{aligned}$$

Similarly, if we suppose the same displacement a is given to b , c , and $b + c$, we obtain the equation

$$V(b + c)a = Vba + Vca$$

which can also be proved from the former case by reversing the order of multiplication, and consequently the sign of each vector product.

We may now extend the distributive law to the case of the vector product of any two factors, each of which is regarded as the sum of two or more vectors.

Let $a = d + e$.

Then by the above result

$$\begin{aligned} V(d + e)(b + c) &= V(d + e)b + V(d + e)c \\ &= Vdb + Veb + Vdc + Vec \end{aligned}$$

This may, similarly, be extended to the case where the two factors contain any number of terms with either plus or minus signs.

EXAMPLE.—Prove the formula

$$\sin(\theta_1 - \theta_2) = \sin \theta_1 \cos \theta_2 - \cos \theta_1 \sin \theta_2$$

directly, by a similar method to that of § 165, using vector products instead of scalar products.

170. Note on the Theory of Multiplication.—Students often feel the difficulty that the definitions of scalar and vector products seem to be chosen in an arbitrary way. Why are these called products? Why is the process of forming them called multiplication? The following note will make this point clearer:—

In arithmetic the product of the two integral numbers 3 and 5 is defined as the result of taking 3 five times over. But even in arithmetic we already extend the notion of a product to cases where we cannot proceed in this way.

E.g., in finding the value of $2 \times \sqrt{3}$ we cannot take two $\sqrt{3}$ times over, since $\sqrt{3}$ cannot be measured exactly in terms of any unit; *i.e.* it is incommensurable. Similarly, a definition of the above form does not apply to such products as $3 \times \frac{1}{6}$, 2×-5 , -2×-3 .

We notice, however, that if a and b are two integral numbers, the product ab satisfies two important laws:—

(1) The commutative law, $ab = ba$;

$$e.g. 3 \times 8 = 24 = 8 \times 3$$

(2) The distributive law, $a(b + c) = ab + ac$;

$$e.g. 3 \times 7 = 3 \times 3 + 3 \times 4$$

We take these two laws together as the definition of multiplication when applied to any two algebraical quantities, whether integral numbers or fractions, positive or negative, commensurable or incommensurable.

The product ab of any two algebraical quantities a and b is defined as a method of combining them which satisfies the above two laws. By repeated use of these two laws, together with laws for addition and subtraction previously found, we obtain all the results of ordinary scalar algebra involving products of the second degree.

When we seek to apply the process of multiplication to vectors we find the important difference that vectors have direction as well as numerical magnitude, and we have to take this into account in multiplying them.

The scalar product of two vectors is defined in such a way as to satisfy both of the above laws. For the vector product of two vectors the second law is the same, while the law $Vab = -Vba$ takes the place of the first of the above laws. The algebra which is developed from the laws which govern these two species of products supplies a powerful method of treating many physical problems.

CHAPTER XXII

SOLID GEOMETRY—POINTS AND STRAIGHT LINES

177. Rectangular Co-ordinates of a Point.—We have seen that the position of a point in a plane is specified by two rectangular co-ordinates x and y , which are its distances from two perpendicular axes. If these two co-ordinates are known, the point is fixed in the plane. If, however, the point is not confined to one plane, but may be anywhere in space, two co-ordinates are not sufficient to define its position, for, even if x and y are known, we may suppose the plane containing the co-ordinates x and y to move up and down a third perpendicular axis Oz , remaining parallel to the original plane of the axes x and y .

In order to fix the position of the point, we require to know a third co-ordinate z , which fixes the position on Oz of this plane containing the point P and its co-ordinates x and y . Thus *three* co-ordinates are required to fix the position of a point in space.

For example, the position of a point in a room is defined when we know its distances from two adjacent walls and the floor.

Accordingly, the position of a point in space is defined as follows:—

Take three axes Ox , Oy , Oz at right angles to each other.

The position of any point P is defined by

- (1) its distance x measured parallel to Ox from the plane Oyz ,
- (2) its distance y measured parallel to Oy from the plane Ozx ,
- (3) its distance z measured parallel to Oz from the plane Oxy .

We may construct a figure to show the position of the point P as follows:—

Measure off lengths equal to x , y , and z along the axes of Ox , Oy , and Oz respectively. Construct a rectangular block or parallelepiped having these three lines as adjacent edges, then the point P is at the corner of the block opposite to O .

The point P , whose co-ordinates are x , y , and z , is known as the point (x, y, z) .

EXAMPLE.—To find the position of the point $(2, 1, 3)$, set off distances 2 along Ox , 1 along Oy , 3 along Oz , and construct a rectangular block having these three lines as edges.

The point $(2, 1, 3)$ is at P in figure 157. We shall represent the position of points and lines in this subject by parallel oblique projection, as in the figure.

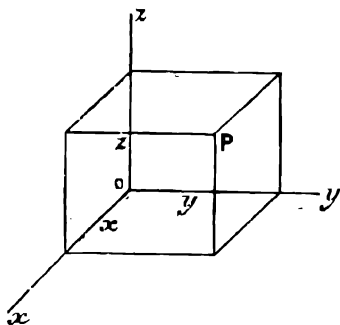

FIG. 156.

The plane of y and z is supposed to be parallel to the paper and facing the reader. The lengths of the co-ordinates y and z will therefore be drawn correctly to scale.

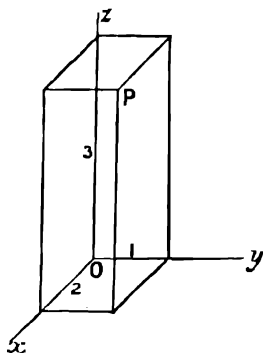

FIG. 157.

The axes of y and z are taken in the direction of the ruling, and all lines parallel to Ox are drawn along or parallel to the diagonals of the squares.

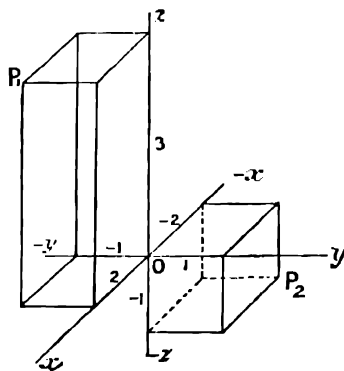

FIG. 158.

178. Signs of the Co-ordinates.

If any co-ordinate is measured from O in the direction shown in Fig. 156, it is positive; if measured in the opposite direction parallel to the corresponding axis produced backward, it is negative.

E.g., the point $(2, -1, 3)$ is shown by measuring the distance 1 along yO produced, and 2 and 3 on the proper scales along Ox and Oz ; on completing the rectangular block as before, we get the point P_1 in Fig. 158.

The co-ordinates of P_2 in Fig. 158 are $(-2, 1, -1)$.

In this case x is measured away from the spectator behind the plane of yOz , and z is measured below the plane xOy .

EXAMPLES.—XCIV.

Draw figures showing clearly the position of each of the following points:—

- | | | |
|--|--------------------|--|
| 1. $(8, 2, 6)$. | 2. $(10, 3, 5)$. | 3. $(1, 1, 0)$; $(1, 0, 1)$; $(0, 1, 1)$. |
| 4. $(1, 0, 0)$; $(0, 1, 0)$; $(0, 0, 1)$. | 5. $(-6, 5, 3)$. | |
| 6. $(7, 4, -2)$. | 7. $(5, -6, -2)$. | |

179. Polar Co-ordinates of a Point.—Consider the case of a point near the door of a room. Its position might be defined as follows. Suppose the door to be opened till it passes through the point. Draw a line from the lower fixed corner of the door to the point. Then if we know the length of this line, and the angle it makes with a line through the hinges, the position of the point is fixed in the door.

These two quantities are the polar co-ordinates, r and θ , of the point in the plane of the door. If in addition we know the angle through which the door is opened the position of the point is fixed in space. We distinguish this angle by the letter ϕ , and the three quantities r , θ , ϕ are the polar co-ordinates of the point in space.

Thus we may define the polar co-ordinates of the point P as follows:—

Take three rectangular axes as before. Let P be the point and join OP . Let a plane through OP and Oz cut the plane Oxy in ON .

Draw PN perpendicular to the plane Oxy , and PM perpendicular to Oz .

The rectangular block whose edges are the rectangular co-ordinates x , y and z of P is thus cut by a diagonal plane in a section which is the rectangle $ONPM$.

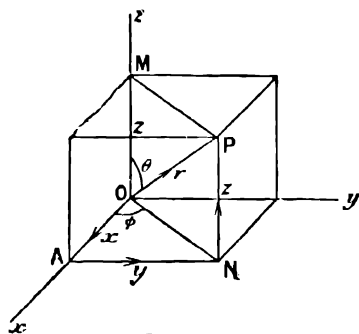

FIG. 159.

The polar co-ordinates of P are—

- (1) The distance r of P from the origin.
- (2) The angle θ between OP and the axis of z .
- (3) The angle ϕ between the plane OPN and the axis of x .

NOTE.—The angle between a straight line and a plane is measured by the angle between the line and its projection on the given plane.

The point P is known as the point (r, θ, ϕ) . Note that in the figure none of the three co-ordinates r , θ , ϕ is drawn with its true value.

180. To find the Rectangular Co-ordinates of a Point when the Polar Co-ordinates are given.

The angle OMP is a right angle, and therefore

$$\frac{OM}{OP} = \frac{z}{r} = \cos \theta, \text{ and } z = r \cos \theta$$

Also $\frac{MP}{r} = \sin \theta$ and $MP = r \sin \theta = ON$.

Also, since OAN is a right angle, $\frac{x}{ON} = \cos \phi$,

$$\text{and } x = ON \cos \phi = r \sin \theta \cos \phi.$$

So also $\frac{y}{ON} = \sin \phi$,

$$\text{and } y = ON \sin \phi = r \sin \theta \sin \phi.$$

Thus, to convert polar to rectangular co-ordinates, we have

$$\begin{aligned} z &= r \cos \theta \\ x &= r \sin \theta \cos \phi \\ y &= r \sin \theta \sin \phi \end{aligned}$$

EXAMPLE.—Find the rectangular co-ordinates of the point whose polar co-ordinates are $(2, 15^\circ, 40^\circ)$, and draw a figure showing its position.

We have

$$\begin{aligned} z &= r \cos \theta = 2 \cos 15^\circ = 2 \times 0.9659 = 1.932 \\ x &= r \sin \theta \cos \phi = 2 \sin 15^\circ \cos 40^\circ \\ &= 2 \times 0.2588 \times 0.7660 \\ &= 0.396 \\ y &= r \sin \theta \sin \phi = 2 \sin 15^\circ \sin 40^\circ \\ &= 0.333 \end{aligned}$$

\therefore the rectangular co-ordinates are —

$$\begin{aligned} x &= 0.396 \\ y &= 0.333 \\ z &= 1.932 \end{aligned}$$

The figure may now be drawn in parallel projection from these values of x , y , and z .

EXAMPLES.—XCV.

Find the rectangular co-ordinates of the points whose polar co-ordinates are given as follows, and draw figures to scale :—

- | | | |
|-------------------------------------|-------------------------------------|-------------------------------------|
| 1. (4, 55° , 44°). | 2. (3, 37° , 51°). | 3. (3, 45° , 120°). |
| 4. (4, 35° , 42°). | 5. (3.2, 52° , 16°). | 6. (2, 31° , 59°). |
| 7. (2, 40° , 56°). | 8. (3, 30° , 45°). | 9. (2, 38° , 52°). |
| 10. (1, 120° , 52°). | 11. (1, 270° , 90°). | 12. (3, 62° , 122°). |

181. To find the Polar Co-ordinates of a Point when the Rectangular Co-ordinates are given.

Let x , y , z , and r be regarded as vectors in the directions shown by the arrows in Fig. 159.

We have, by vector addition,

$$x + y + z = r$$

Squaring

$$(x + y + z)^2 = r^2$$

$$x^2 + y^2 + z^2 + 2xy + 2yz + 2zx = r^2$$

where the products are scalar products.

$$\therefore x^2 + y^2 + z^2 + 2xy \cos 90^\circ + 2yz \cos 90^\circ + 2zx \cos 90^\circ = r^2$$

But $\cos 90^\circ = 0$.

$$\therefore x^2 + y^2 + z^2 = r^2$$

This gives $r = \sqrt{x^2 + y^2 + z^2}$.

$$\cos \theta = \frac{z}{r} = \frac{z}{\sqrt{x^2 + y^2 + z^2}}$$

$$\tan \phi = \frac{NA}{AO} = \frac{y}{x}$$

These equations give r , θ , and ϕ .

EXAMPLE.—Find the polar co-ordinates of the point whose rectangular co-ordinates are (4, 3, 2).

NOTE.—In examples such as this the student should always draw the figure, and obtain the results directly from the geometry of the case, and not from the formulæ alone.

He should form a definite mental picture of the co-ordinates in space, and should

not form the habit of simply working from the formulæ alone, if he does so the examples will become mere practice in arithmetic, and not in geometry.

In the figure

$$ON^2 = 3^2 + 4^2 = 25$$

$$\therefore ON = 5$$

$$r^2 = ON^2 + NP^2 = 25 + 4 = 29$$

$$\therefore r = \sqrt{29} = 5.38$$

$$\cos \theta = \frac{z}{r} = \frac{2}{5.38} = 0.372$$

$$\therefore \theta = 68^\circ$$

$$\tan \phi = \frac{y}{x} = 0.75$$

$$\therefore \phi = 37^\circ$$

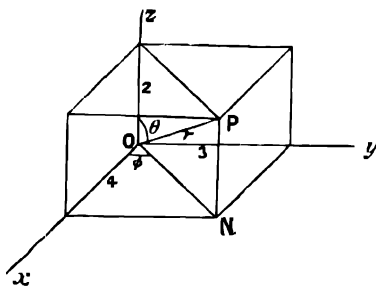

FIG. 160.

and the polar co-ordinates are $(5.38, 68^\circ, 37^\circ)$.

EXAMPLES.—XCVI.

Find the polar co-ordinates of the points whose rectangular co-ordinates are given as follows:—

Give the values of θ and ϕ to the nearest degree. Draw a figure to scale in each case.

1. $x = 8, y = 4, z = 5.$

3. $x = 4, y = 2, z = -2.$

5. $x = 6, y = 4, z = 8.$

7. $x = 3, y = -2, z = 1.$

9. $x = 18, y = 10, z = 15.$

11. $x = 12, y = -3, z = -4.$

12. Prove that $x^2 + y^2 + z^2 = r^2$ without using vector algebra.

2. $x = 10, y = 5, z = 4.$

4. $x = 8, y = 2, z = 5.$

6. $x = 1, y = 1, z = 1.$

8. $x = 6, y = 4, z = 3.$

10. $x = 8, y = -2, z = 3.$

182. Direction of a Straight Line in Space.—The direction of a straight line in space may be specified by the three angles $\alpha, \beta,$ and $\gamma,$ which it makes with the three axes of x, y and z respectively.

If the line does not pass through the origin we can specify the direction by considering the case of a line parallel to it through the origin, so that we need only consider the case of a straight line through the origin.

Take any point P on this line and complete the rectangular block, having the co-ordinates of P as its edges.

Then, with the same notation as before, PMO is a right-angled triangle, and

$$\cos \gamma = \frac{OM}{OP} = \frac{z}{r}$$

Similarly, if we join PA, PAO is a right-angled triangle, and

$$\cos \alpha = \frac{OA}{OP} = \frac{x}{r}$$

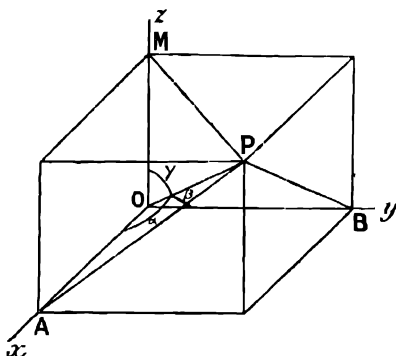

FIG. 161.

Similarly, joining **PB**, we get $\cos \beta = \frac{y}{r}$

$\cos \alpha$, $\cos \beta$, and $\cos \gamma$, are called the **direction cosines** of the line **OP**.

We write $\cos \alpha = l$, $\cos \beta = m$, $\cos \gamma = n$, and use the direction cosines l , m , n , to specify the direction of the straight line **OP**.

Note that the angle γ is the same as the polar co-ordinate θ of the point **P**.

EXAMPLE.—The rectangular co-ordinates of a point **P** are 6, 3, 3. Find the angles which **OP** makes with the three axes **Ox**, **Oy**, and **Oz**.

We have

$$r = \sqrt{x^2 + y^2 + z^2} = \sqrt{36 + 9 + 9} = 7.35$$

$$\cos \alpha = \frac{x}{r} = \frac{6}{7.35} = 0.828 ; \therefore \alpha = 34^\circ$$

$$\cos \beta = \frac{y}{r} = \frac{3}{7.35} = 0.414 ; \therefore \beta = 65.5^\circ$$

$$\cos \gamma = \frac{z}{r} = \frac{3}{7.35} = 0.414 ; \therefore \gamma = 65.5^\circ$$

and the required angles are

$$\alpha = 34^\circ, \beta = 65.5^\circ, \gamma = 65.5^\circ$$

183. $l^2 + m^2 + n^2 = 1$.—Considering the case where the position of **P** is such that all its co-ordinates are positive, we see that any two of the angles α , β , γ would be sufficient to fix the direction of the line **OP**. There must, therefore, be some relation connecting α , β , and γ so that the third angle may be determined when any two are given.

With the same notation as before, we have

$$\cos \alpha = \frac{x}{r} = \frac{x}{\sqrt{x^2 + y^2 + z^2}}$$

$$\cos \beta = \frac{y}{r} = \frac{y}{\sqrt{x^2 + y^2 + z^2}}$$

$$\cos \gamma = \frac{z}{r} = \frac{z}{\sqrt{x^2 + y^2 + z^2}}$$

Squaring and adding, we get

$$\cos^2 \alpha + \cos^2 \beta + \cos^2 \gamma = \frac{x^2 + y^2 + z^2}{x^2 + y^2 + z^2} = 1$$

$$\text{i.e. } l^2 + m^2 + n^2 = 1$$

This corresponds to the relation $\cos^2 \theta + \sin^2 \theta = 1$ in plane geometry.

If we have two of the angles α , β , and γ given, we may now find the third angle.

EXAMPLE.—A straight line makes angles of 60° and 70° with the axes of x and z respectively. Find the angle which it makes with the axis of y .

We have $\alpha = 60^\circ$, $\gamma = 70^\circ$.

We require to find β .

$$\cos^2 \alpha + \cos^2 \beta + \cos^2 \gamma = 1$$

$$\cos^2 \beta = 1 - \cos^2 \alpha - \cos^2 \gamma$$

$$= 1 - \cos^2 60^\circ - \cos^2 70^\circ$$

$$= 1 - (0.5)^2 - (0.342)^2$$

$$= 1 - 0.25 - 0.1170$$

$$= 1 - 0.3670 = 0.6330$$

$$\cos \beta = \sqrt{0.6330} = 0.796$$

$$\therefore \beta = 37.25^\circ$$

184. Angle between a Straight Line and each of the Co-ordinate Planes.—The angle which a straight line makes with a plane is defined as the angle which the straight line makes with its projection on the plane.

In Fig. 160 the angle between OP and the plane Oxy is

$$NOP = 90^\circ - POM = 90^\circ - \gamma$$

Similarly, the angle between OP and the plane Oyz is $90^\circ - \alpha$; and the angle between OP and the plane Ozx is $90^\circ - \beta$.

The angle between a given straight line and any co-ordinate plane is the complement of the angle between the line and the axis, which is perpendicular to that plane.

E.g. in example, § 183.

$$\alpha = 60^\circ, \beta = 37^\circ, \gamma = 70^\circ$$

$\therefore OP$ makes angles of 30° with the plane Oyz , 53° with the plane Ozx , and 20° with the plane Oxy .

185. Representation on a Sphere.—Consider a sphere of unit radius with its centre at the origin.

Let the axes cut the surface of this sphere in the points x, y , and z , and let OP cut the surface in P .

Then, since the radius of the sphere is unity, the planes POx , POy , and POz will cut the surface of the sphere in arcs whose lengths are numerically equal to the values of α, β , and γ .

Thus the angles which OP makes with the three axes may be represented on the surface of a sphere, as shown in Fig. 162.

Thus the arc zPn in the figure is equal to $\frac{\pi}{2}$, the arc $zP = \gamma$, and the arc Pn which measures the angle between OP and the plane

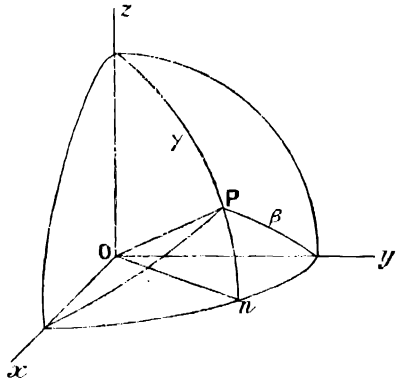

FIG. 162.

Oxy , is equal to $\frac{\pi}{2} - \gamma$.

186. EXAMPLE (1).—The rectangular co-ordinates of a point P are $(10, 4, 3)$; find the angles which OP makes with the three axes of co-ordinates.

We have

$$OP = r = \sqrt{x^2 + y^2 + z^2} = \sqrt{125} = 11.18$$

$$\cos \alpha = \frac{x}{r} = \frac{10}{11.18} = 0.895 = \cos 26.5^\circ; \therefore \alpha = 26.5^\circ$$

$$\cos \beta = \frac{y}{r} = \frac{4}{11.18} = 0.358 = \cos 69^\circ; \therefore \beta = 69^\circ$$

$$\cos \gamma = \frac{z}{r} = \frac{3}{11.18} = 0.2685 = \cos 74.4^\circ; \therefore \gamma = 74.4^\circ$$

EXAMPLE (2).—The polar co-ordinates of a point P are $(5, 36^\circ, 42^\circ)$; find the angles between OP and the three axes of rectangular co-ordinates.

We have

$$\begin{aligned}\gamma &= \theta = 36^\circ \\ \cos \alpha &= \frac{x}{r} = \frac{r \sin \theta \cos \phi}{r} = \sin \theta \cos \phi \\ &= \sin 36^\circ \cos 42^\circ = 0.588 \times 0.743 = 0.437 = \cos 64^\circ \\ \therefore \alpha &= 64^\circ \\ \cos \beta &= \frac{y}{r} = \frac{r \sin \theta \sin \phi}{r} = \sin \theta \sin \phi \\ &= \sin 36^\circ \sin 42^\circ = 0.588 \times 0.669 = 0.393 = \cos 67^\circ \\ \therefore \beta &= 67^\circ\end{aligned}$$

and the three angles which **OP** makes with the axes are

$$\alpha = 64^\circ, \beta = 67^\circ, \gamma = 36^\circ$$

EXAMPLES.—XCVII.

1. The rectangular co-ordinates of a point **P** are (8, 3, 2). Draw a figure to scale to show its position, and calculate the direction cosines of **OP**, and the angles which it makes with the axes of co-ordinates.

2. The rectangular co-ordinates of **P** are (5, 2, 3). Find the angles which **OP** makes with the co-ordinate planes, and the projection of **OP** on the plane **Oyz**.

3. The rectangular co-ordinates of **P** are (3, 4, 6). Find the direction cosines of **OP**.

4. A rectangular block has its edges 3, 4, and 7 in. long. Find the length of its diagonal and the angles which its diagonal makes with each of the three edges.

5. The polar co-ordinates of a point **P** are (3, 57°, 39°). Find the direction cosines of **OP**.

6. The polar co-ordinates of **P** are (3.2, 52°, 16°). Find the angles which **OP** makes with the three axes of rectangular co-ordinates.

7. The polar co-ordinates of **P** are (2, 31°, 59°). Find the angles which **OP** makes with the three co-ordinate axes.

8. The polar co-ordinates of **P** are (5, 48°, 60°). Find the projection of **OP** on the plane **Oxz**.

9. A straight line **OP**, 3 in. long, is drawn from the origin so as to make angles of 52° and 65° with the axes of **x** and **z** respectively. Find the rectangular co-ordinates of the point **P**.

10. A straight line, 3.52 in. long, makes angles of 59° and 67° with **Ox** and **Oy** respectively. Find the lengths of its projections on the three axes.

11. A straight line makes angles of 40° and 60° with the axes of **y** and **x** respectively. What angle does it make with the axis of **z**?

12. A straight line makes angles of 59° and 73° with **Oz** and **Ox** respectively. What angle does it make with **Oy**?

13. For a certain straight line $\alpha = 52^\circ, \gamma = 65^\circ$. Find β .

14. If $\alpha = 59^\circ, \beta = 67^\circ$. Find γ .

15. A straight line makes angles of 55° with **Ox** and 71° with **Oy**. What angle does it make with the plane **Oxy**?

187. To find the Length and Direction of the Line joining two given Points.

EXAMPLE.—The rectangular co-ordinates of a point **A** are (4, 3, 2), and of a point **B** (8, 5, 3). Find the length and direction cosines of the straight line **AB**.

Construct the rectangular blocks formed by the co-ordinates of **A** and **B**.

Then, if we produce the edges of the block formed by the co-ordinates of **A** until they meet the faces of the block formed by the co-ordinates of **B**, we obtain a third rectangular block, having **AB** as its diagonal. The edges of this block are

$$\begin{array}{rcl} 8 - 4 = 4 & \text{parallel to} & \mathbf{Ox} \\ 5 - 3 = 2 & \text{,,} & \mathbf{Oy} \\ 3 - 2 = 1 & \text{,,} & \mathbf{Oz} \end{array}$$

∴ the problem is the same as if **A** were the origin, and the co-ordinates of **B** were (4, 2, 1).

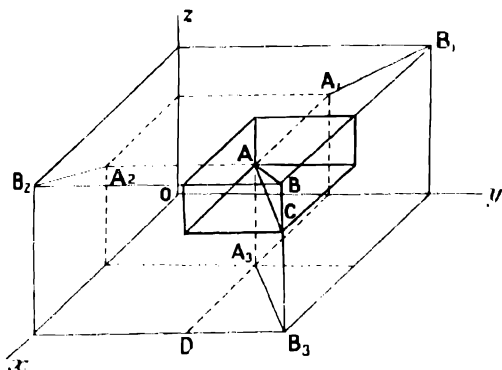

FIG. 163.

$$\begin{aligned} \therefore AB &= \sqrt{16 + 4 + 1} = 4.583 \\ l = \cos \alpha &= \frac{4}{4.583} = 0.874 \\ m = \cos \beta &= \frac{2}{4.583} = 0.437 \\ n = \cos \gamma &= \frac{1}{4.583} = 0.2185 \end{aligned}$$

EXAMPLES.—XCVIII.

Find the length and direction cosines of the line **AB** when the co-ordinates of **A** and **B** are given as follows. Draw a figure in each case.

- | | |
|---|--|
| 1. A (1, 1, 1); B (3, 4, 3). | 2. A (2, 2, 2); B (6, 4, 5). |
| 3. A (8, 2, 4); B (10, 3, 3). | 4. A (4, 2, 1); B (7, 3, 4). |
| 5. A (2, 2, 3); B (4, 3, 5). | |

6. A straight line **AB** makes angles of 42° with **Ox**, and 53° with **Oz**; what angle does it make with **Oy**? If the line is 4 inches long, and is placed so that the end **A** is at the origin, what are the co-ordinates of the other end **B**?

7. If the end **A** of the line **AB** in example 6 is placed at the point (1, 1, 1), and its direction remains the same, what are the rectangular co-ordinates of **B**? Draw a figure to scale.

8. **A** is a point whose co-ordinates are (9, 3, 4). A straight line **AB** 5 units long is drawn through **A** in a direction making an angle of 59° with **Oy**, and 44° with the plane **Oxy**. Find the rectangular co-ordinates of **B**.

188. Projections of a Line on the Three Co-ordinate Planes.—In Fig. 163, **A₁B₁**, **A₂B₂**, **A₃B₃** are the projections of **AB** on the planes **Oyz**, **Oxz**, **Oxy** respectively.

As an example we shall consider the case where the co-ordinates of **A** are (4, 3, 2), and of **B** (8, 5, 3), as in Fig. 163.

To find the length of the projection **A₃B₃** of **AB** on the plane **Oxy**, we have co-ordinates of **A₃** are $x = 4, y = 3$; co-ordinates of **B₃** are $x = 8, y = 5$.

$$\therefore A_3D = 8 - 4 = 4$$

$$DB_3 = 5 - 3 = 2$$

$$\text{and } A_3B_3 = \sqrt{20} = 4.47$$

$$\text{Similarly } A_1B_1 = \sqrt{4 + 1} = 2.24$$

$$\text{and } A_2B_2 = \sqrt{16 + 1} = 4.12$$

When the length and direction cosines l, m, n of AB are known, its projections on the three co-ordinate planes may also be found as follows:—

$$\text{We have angle } ABC = \gamma; A_3B_3 = AC = AB \sin \gamma = AB \sqrt{1 - n^2}.$$

$$\text{Similarly } A_1B_1 = AB \sin \alpha = AB \sqrt{1 - l^2}$$

$$A_2B_2 = AB \sin \beta = AB \sqrt{1 - m^2}$$

189. To find the Length and Position of a Straight Line when its Projections on Two Perpendicular Planes are given.—On reference to Fig. 163, it is seen that a straight line is determined by its projections on any two of the co-ordinate planes, for if A_2B_2 and A_3B_3 are given, a plane through A_2B_2 perpendicular to the plane Ozx and a plane through A_3B_3 perpendicular to the plane Oxy will intersect in the required line AB .

The co-ordinates of A are the same as the corresponding co-ordinates of A_2 and A_3 , viz.—

the x co-ordinate of A = the x co-ordinate of A_2 and A_3

“ y “ “ “ A = “ y “ “ A_3

“ z “ “ “ A = “ z “ “ A_2

Similarly, the co-ordinates of B are the same as the corresponding co-ordinates of B_2 and B_3 .

The co-ordinates of A and B are now known, and the length and direction cosines of AB may be found.

EXAMPLE.—The projections A_1B_1 and A_3B_3 of AB on the planes Oyz and Oxy respectively are given as follows:—

The co-ordinates of A_1 are (0, 4, 2) of B_1 (0, 7, 4)

“ “ A_3 are (5, 4, 0) of B_3 (8, 7, 0)

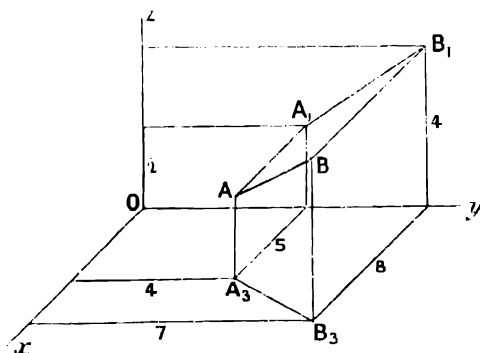

FIG. 164.

Draw a figure showing the position of AB , and calculate its length and the angles which it makes with the axes of co-ordinates.

From the figure the co-ordinates of **A** and **B** are (5, 4, 2) and (8, 7, 4) respectively. The length and direction cosines of **AB** may now be found

$$AB = \sqrt{9 + 9 + 4} = 4.69$$

To find the angle which **AB** makes with the axis of *z*, we have

$$\begin{aligned} A_z B_z &= \sqrt{9 + 9} = 4.24 \\ \therefore \sin \gamma &= \frac{A_z B_z}{AB} = 0.905 \\ \therefore \gamma &= 64.8^\circ \end{aligned}$$

Similarly, α and β may be found.

EXAMPLES.—XCIX

1. Write down the values of the angles which **AB** makes with each of the three co-ordinate planes in Examples XCVIII., 1-4.

2. Draw figures to show the projections of **AB** on the three co-ordinate planes in Examples XCVIII., 1-4. Calculate the length of the projection on the plane **Oxy** in each case.

3. Find the distance between the points (1, 2, 1) and (3, 3, -2), draw a figure to show the position of the points and the line joining them, and find the angle which the joining line makes with the plane **Oxy**.

$A_1 B_1, A_2 B_2, A_3 B_3$ are the projections of a straight line **AB** on the planes **Oyz, Ozx, Oxy** respectively. Draw figures to show the position of **AB**, and calculate its length when the co-ordinates of the following points are given:—

- | | |
|--|--|
| <p>4. $A_1(0, 4, 2); B_1(0, 6, 5).$
 $A_3(5, 4, 0); B_3(7, 6, 0).$</p> | <p>5. $A_2(4, 0, 5); B_2(7, 0, 5).$
 $A_3(4, 8, 0); B_3(7, 4, 0).$</p> |
| <p>6. $A_1(0, 1, 3); B_1(0, 4, 5).$
 $A_2(5, 0, 3); B_2(6, 0, 5).$</p> | |

7. Find the angles which **AB** in example 4 makes with the planes **Oxy** and **Oyz**.

8. Find the angle which **AB** in example 4 makes with the plane **Ozx**, draw a figure to show the projection $A_2 B_2$ of **AB** on the plane **Ozx**, and calculate the length of $A_2 B_2$.

9. A straight line **PQ**, 5 inches long, makes angles of 45° with **Ox** and 55° with **Oz**. Find the lengths of its projections on the three co-ordinate planes.

190. Angle between Two given Straight Lines.—Let **OP** and **OQ** be two given lines whose direction cosines are (l_1, m_1, n_1) and (l_2, m_2, n_2) respectively. We require to find the angle $POQ = \theta$ between **OP** and **OQ**.

Let **OP** = r_1 , **OQ** = r_2 , and let the co-ordinates of **P** and **Q** be (x_1, y_1, z_1) and (x_2, y_2, z_2) respectively.

$$\begin{aligned} \text{Then } l_1 &= \frac{x_1}{r_1}, m_1 = \frac{y_1}{r_1}, n_1 = \frac{z_1}{r_1} \\ l_2 &= \frac{x_2}{r_2}, m_2 = \frac{y_2}{r_2}, n_2 = \frac{z_2}{r_2} \end{aligned}$$

Consider x_1, y_1, z_1, r_1 and x_2, y_2, z_2, r_2 as vectors. Then, by vector addition,

$$\begin{aligned} r_1 &= x_1 + y_1 + z_1 \\ r_2 &= x_2 + y_2 + z_2 \end{aligned}$$

By multiplication, we get the scalar product

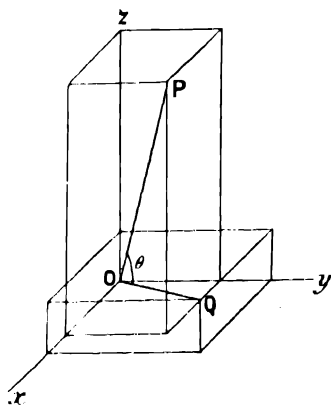

FIG. 165.

$$\begin{aligned} r_1 r_2 &= (x_1 + y_1 + z_1)(x_2 + y_2 + z_2) \\ &= x_1 x_2 + y_1 y_2 + z_1 z_2 + x_1 y_2 + x_1 z_2 + y_1 z_2 \\ &\quad + y_1 x_2 + z_1 x_2 + z_1 y_2 \quad (\text{p. 298}) \end{aligned}$$

Since the scalar product of two linear vectors is the product of their lengths into the cosine of the angle between them, the last 6 terms in this expression vanish, being the scalar products of pairs of perpendicular vectors.

∴ we have

$$\begin{aligned} r_1 r_2 \cos \theta &= x_1 x_2 \cos 0^\circ + y_1 y_2 \cos 0^\circ \\ &\quad + z_1 z_2 \cos 0^\circ \\ &= x_1 x_2 + y_1 y_2 + z_1 z_2 \end{aligned}$$

$$\begin{aligned} \therefore \cos \theta &= \frac{x_1 x_2}{r_1 r_2} + \frac{y_1 y_2}{r_1 r_2} + \frac{z_1 z_2}{r_1 r_2} \\ &= l_1 l_2 + m_1 m_2 + n_1 n_2 \end{aligned}$$

EXAMPLE (1).—Find to the nearest degree the angle θ between the straight lines OP and OQ, when the co-ordinates of P and Q are (3, 2, 5), and (4, 3, 1) respectively.

This case is shown in Fig. 165.

Let the direction cosines of OP and OQ be (l_1, m_1, n_1) , and (l_2, m_2, n_2) respectively.

We have

$$OP = \sqrt{9 + 4 + 25} = \sqrt{38}$$

$$OQ = \sqrt{16 + 9 + 1} = \sqrt{26}$$

$$l_1 = \cos x OP = \frac{3}{\sqrt{38}}, \quad l_2 = \cos x OQ = \frac{4}{\sqrt{26}}$$

$$m_1 = \cos y OP = \frac{2}{\sqrt{38}}, \quad m_2 = \cos y OQ = \frac{3}{\sqrt{26}}$$

$$n_1 = \cos z OP = \frac{5}{\sqrt{38}}, \quad n_2 = \cos z OQ = \frac{1}{\sqrt{26}}$$

$$\begin{aligned} \therefore \cos \theta &= l_1 l_2 + m_1 m_2 + n_1 n_2 \\ &= \frac{12}{\sqrt{38} \sqrt{26}} + \frac{6}{\sqrt{38} \sqrt{26}} + \frac{5}{\sqrt{38} \sqrt{26}} \\ &= \frac{23}{\sqrt{988}} = 0.732 = \cos 43^\circ \end{aligned}$$

$$\therefore \text{POQ} = \theta = 43^\circ$$

EXAMPLE (2).—The polar co-ordinates of two points P and Q are $(2, 15^\circ, 45^\circ)$, and $(3, 56^\circ, 60^\circ)$ respectively. Find the angle θ between OP and OQ.

With the same notation as before, we have

$$l_1 = \frac{x_1}{r_1} = \frac{2 \sin 15^\circ \cos 45^\circ}{2} = 0.2588 \times 0.7071 = 0.1832$$

$$m_1 = \frac{y_1}{r_1} = \frac{2 \sin 15^\circ \sin 45^\circ}{2} = 0.1832$$

$$n_1 = \frac{z_1}{r_1} = \frac{2 \cos 15^\circ}{2} = 0.9659$$

$$l_2 = \frac{3 \sin 56^\circ \cos 60^\circ}{3} = 0.8290 \times 0.5 = 0.4145$$

$$m_2 = \frac{3 \sin 56^\circ \sin 60^\circ}{3} = 0.8290 \times 0.866 = 0.7175$$

$$n_2 = \frac{3 \cos 56^\circ}{3} = 0.5592$$

$$\therefore \cos \theta = l_1 l_2 + m_1 m_2 + n_1 n_2 = 0.076 + 0.132 + 0.540 = 0.748 = \cos 41.5^\circ$$

$$\therefore \text{POQ} = \theta = 41.5^\circ$$

Since the direction cosines of a line from **O** are proportional to the rectangular co-ordinates of any point on it, the figure may be drawn in parallel projection when the direction cosines of the two lines are known.

EXAMPLES.—C.

1. The straight line **AB** makes angles of 50° and 40° with **Ox** and **Oy** respectively. **AC** makes angles 43° and 61° with **Ox** and **Oy**. Calculate the angle **BAC**.

2. **OA** makes 32° with **Ox** and 74° with **Oy**.

OB „ 67° „ **Ox** „ 60° „ **Oy**.

Find the angle **AOB**.

3. **OP** makes 45° with **Ox** and 50° with **Oy**.

OQ „ 60° „ **Ox** „ 70° „ **Oy**.

Find the angle **POQ** and the length of the line **PQ**, taking **OP** = 1 and **OQ** = 1.

4. The rectangular co-ordinates of **P** are (3, 4, 1), of **Q** (2, 4, 3). Find the angle between **OP** and **OQ** correct to the nearest degree.

5. Co-ordinates of **P** are (4, 2, 1) and of **Q** (2.5, 2, 3). Find the angle **POQ**, and draw a figure to scale in oblique parallel projection.

6. Co-ordinates of **P** are (5, 1, 5) and of **Q** (1, 6, 2). Find the angle **POQ**, and draw a figure.

7. Co-ordinates of **P** are (1.5, 0.8, 1.2) and of **Q** (1.2, 2.8, 1.7). Find the angle **POQ**, the length of **PQ**, and the angles which it makes with the three axes.

8. Co-ordinates of **P** are (3, 4, 1) and of **Q** (-3, 4, 1). Find the angle **POQ**, and draw a figure.

9. The polar co-ordinates of **P** are (3, 45° , 30°) and of **Q** (3, 60° , 50°). Find the angle **POQ**.

10. Verify that the relation

$$\cos \theta = l_1 l_2 + m_1 m_2 + n_1 n_2$$

holds good when the two straight lines are **Ox** and **Oy**, and also when the two straight lines are in the directions **Ox** and **yO**.

CHAPTER XXIII

SOLID GEOMETRY—PLANES

191. Traces of a Plane.—Any plane cuts the three co-ordinate planes in three straight lines, called its traces, forming a triangle.

Any two of the traces are sufficient to determine the plane.

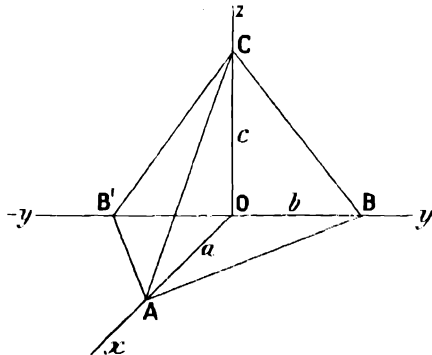

FIG. 166.

Thus, in Fig. 116, AB, BC, and CA are the traces of the plane ABC. We shall denote the lengths OA, OB, OC which the plane cuts off from the axes by a , b , c , taken positive when measured in the positive direction along the axes.

We shall use a , b , c with this meaning to specify the position of a plane by means of its traces.

Thus, in Fig. 116, for the plane ABC

$$a = 3, b = 1.7, c = 2.1,$$

and for the plane AB'C

$$a = 3, b = -1.6, c = 2.1$$

To find the lengths of the traces we have

$$AB = \sqrt{a^2 + b^2}, BC = \sqrt{b^2 + c^2}, CA = \sqrt{c^2 + a^2}$$

192. Measurement of Angles between Straight Lines and Planes.—A straight line is said to be perpendicular to a plane when it is perpendicular to every straight line in that plane.

The angle between two planes is measured by the angle between two

lines drawn one in each plane perpendicular to the line of intersection of the two planes.

In Fig. 167 $OPQR$ is a rectangle; OP and Oy' are perpendicular to the line of intersection Ox of the two planes $OPQR$ and Oxy ; the angle between the two planes is yOP or POy' .

Draw OT perpendicular to the plane $OPQR$.

Then, if we suppose the plane $OPQR$ to lie originally in the plane Oxy , so that OT coincides with Oz , and to rotate about Ox to its present position, OT evidently turns through the same angle as OP , and therefore the angle $zOT = yOP =$ angle between the planes $OPQR$ and Oxy .

Thus the angle between any two planes is equal to the angle between two perpendiculars to the respective planes.

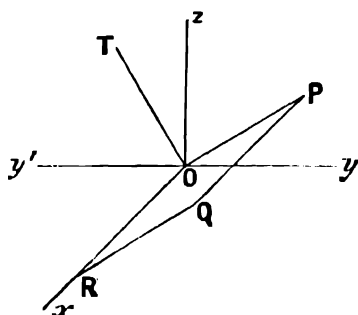

FIG. 167.

193. Length and Direction of the Perpendicular from the Origin to a given Plane.—Let OP be the perpendicular from the origin to the plane ABC , p its length, and (l, m, n) its direction cosines.

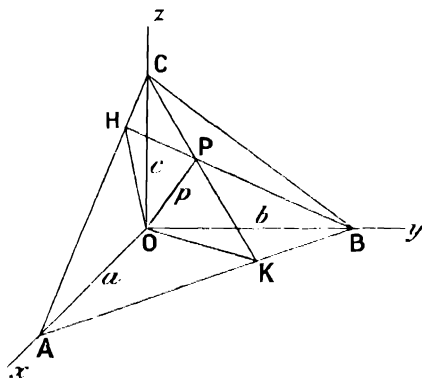

FIG. 168.

In the figure BPO is a right angle, and

$$m = \cos yOP = \frac{p}{b}, n = \cos zOP = \frac{p}{c}, l = \cos xOP = \frac{p}{a}$$

$$\therefore \frac{p^2}{a^2} + \frac{p^2}{b^2} + \frac{p^2}{c^2} = l^2 + m^2 + n^2 = 1 \quad (\text{p. 314})$$

$$p^2 \left(\frac{1}{a^2} + \frac{1}{b^2} + \frac{1}{c^2} \right) = 1$$

$$\therefore p = \frac{1}{\sqrt{\frac{1}{a^2} + \frac{1}{b^2} + \frac{1}{c^2}}}$$

$$\text{and } l = \frac{p}{a} = \frac{\frac{1}{a}}{\sqrt{\frac{1}{a^2} + \frac{1}{b^2} + \frac{1}{c^2}}}$$

$$m = \frac{p}{b} = \frac{\frac{1}{b}}{\sqrt{\frac{1}{a^2} + \frac{1}{b^2} + \frac{1}{c^2}}}$$

$$n = \frac{p}{c} = \frac{\frac{1}{c}}{\sqrt{\frac{1}{a^2} + \frac{1}{b^2} + \frac{1}{c^2}}}$$

EXAMPLE.—A plane, **ABC**, cuts off lengths $a = 6$, $b = 4$, $c = 3$, from the axes of x , y , and z . Find the length and direction cosines of the perpendicular from **O** to this plane.

These values are taken in Fig. 168.

We have

$$\frac{1}{p} = \sqrt{\frac{1}{a^2} + \frac{1}{b^2} + \frac{1}{c^2}} = \sqrt{\frac{1}{36} + \frac{1}{16} + \frac{1}{9}} = \frac{\sqrt{29}}{12}$$

$$\therefore p = \frac{12}{\sqrt{29}} = 2.23$$

$$l = \frac{p}{a} = \frac{2.23}{6} = 0.37$$

$$m = \frac{p}{b} = \frac{2.23}{4} = 0.56$$

$$n = \frac{p}{c} = \frac{2.23}{3} = 0.74$$

To find the position of **P** in the figure, drawn in parallel projection, we note that, if **BP** and **CP** are produced to meet the opposite traces in **H** and **K**, it may be shown by plane geometry that in the right-angled triangle **OCA**,

$$\text{AH} : \text{HC} = a^2 : c^2$$

So also

$$\text{AK} : \text{KB} = a^2 : b^2$$

Accordingly, to draw the figure, we first find the points **H** and **K**; then the intersection of **BH** and **CK** gives the position of **P** in the plane.

104. Inclination of a given Plane to the Axes and to the Co-ordinate Planes.—In Fig. 168 **PB** is the projection of **OB** on the plane **ABC**, and the angle **OBP** or its supplement measures the angle between the plane **ABC** and the axis of y . But

$$\sin \text{OBP} = \frac{p}{b} = \frac{\frac{1}{b}}{\sqrt{\frac{1}{a^2} + \frac{1}{b^2} + \frac{1}{c^2}}}$$

This gives the angle between the plane and the axis of y . Similarly, the angles between the plane and the axes of z and x may be found.

The angles between the plane **ABC** and the co-ordinate planes are the complements of the angles between **ABC** and the axes.

Thus the angle between **ABC** and **Ozx** is measured by the angle **OHB** = complement of **OBP**, which has been found.

EXAMPLE.—A plane, **ABC**, cuts off lengths of 8, 4, 5 from **Ox**, **Oy**, and **Oz**, respectively. Find the angles (1) between the plane **ABC** and the axis of *y*; (2) between **ABC** and the plane **Oxy**.

We have

$$p = \frac{1}{\sqrt{\frac{1}{a^2} + \frac{1}{b^2} + \frac{1}{c^2}}} = \frac{1}{\sqrt{\frac{1}{64} + \frac{1}{16} + \frac{1}{25}}} = 2.907$$

$$\sin \text{OBP} = \frac{p}{b} = \frac{2.907}{4} = 0.727 = \sin 46.6^\circ$$

$$\therefore \text{OBP} = 46.6^\circ$$

The angle between the planes **ABC** and **Oxy** = **OKC** = **COP**, and

$$\cos \text{COP} = \frac{p}{c} = \frac{2.907}{5} = 0.5816 = \cos 54.4^\circ$$

Thus the plane **ABC** makes angles of 46.6° with the axis of *y*, and 54.4° with the plane **Oxy**.

EXAMPLES.—CI.

1. The traces of a plane on the three co-ordinate planes join the points (10, 0, 0), (0, 7, 0), (0, 0, 6). Draw a figure to scale to show the positions of the plane, and of the foot of the perpendicular drawn from the origin to the plane.

2. *a*, *b*, *c* are the lengths cut off from the three axes of co-ordinates by the plane **ABC**.

Draw figures to scale to show the position of the plane **ABC** in the following cases:—

$$\begin{aligned} a &= 20, b = 16, c = 12 \\ a &= 20, b = -10, c = 15 \\ a &= -26, b = 12, c = -14 \end{aligned}$$

3. The traces of a plane **ABC** join the points (3, 0, 0), (0, 2, 0), (0, 0, 4). Find (1) the length of the perpendicular **OP** from **O** to the plane **ABC**, (2) the angles between the plane **ABC** and the axes of *x* and *y*, (3) the angles which the plane **ABC** makes with the planes **Oyz** and **Ozx**.

4. A plane **ABC** cuts off lengths, *a* = 8, *b* = 5, *c* = 3, from the axes of *x*, *y*, and *z* respectively. Draw a figure and find (1) the length of the perpendicular **OP** from the origin to the plane **ABC**, (2) the angles which **OP** makes with the three axes, (3) the angles which the plane **ABC** makes with the axis of *z* and the plane **Ozx**.

195. Line of Intersection of Two Planes.

The intersection of two planes is a straight line which must pass through the intersections of each pair of traces, produced if necessary.

In the figure **QPR** is the intersection of the planes **ABC** and **A₁B₁C₁**, which cut off lengths (10, 5, 3) and (3, 4, 5) from the axes.

Note that in the figure the three points of intersection **Q**, **P**, **R** must lie in a straight line.

To find the projection of QPR on the plane Oxy , we already have one point R where QPR crosses the plane Oxy .

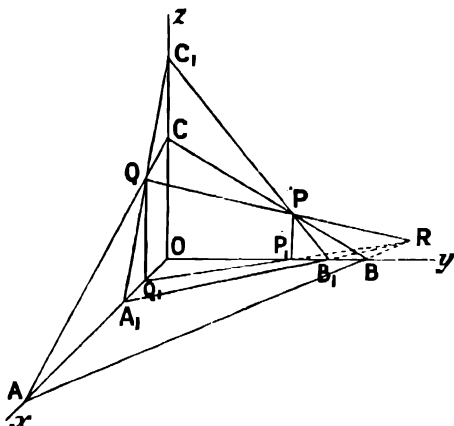

FIG. 169.

Another point on the required projection will be given by the projection of Q or P on the axis of x or y . In the figure Q_1P_1R is the projection of QPR on the plane Oxy .

EXAMPLES.—CII.

1. Two planes cut off lengths (a, b, c) and (a_1, b_1, c_1) from the axes of $x, y,$ and z respectively. Draw figures to show their line of intersection by means of its traces on the three co-ordinate planes, and the projection of this line of intersection on the plane Oxy .

$$(a) \ a = 1, \ b = 2, \ c = 1; \ a_1 = 2, \ b_1 = 2.5, \ c_1 = 3$$

$$(b) \ a = 2, \ b = 3, \ c = 1; \ a_1 = -3, \ b_1 = 2, \ c_1 = 2$$

$$(c) \ a = 3, \ b = 3, \ c = 3; \ a_1 = -3, \ b_1 = -3, \ c_1 = 4$$

Note that in γ the line is parallel to the plane Oxy , and the trace in that plane is at infinity.

2. If $a = 5, b = 3, c = 3, a_1 = 3, b_1 = 4, c_1 = 6$, find by construction and measurement the co-ordinates of the points $P, Q,$ and R , in which the line of intersection of the two planes cuts the three co-ordinate planes.

196. **Angle between Two given Planes.**—To find the angle between two planes whose traces are given.

Let ABC and $A_1B_1C_1$ (Fig. 170) be the given planes, and let OP and OP_1 be perpendiculars from the origin to these planes. Then the required angle θ between ABC and $A_1B_1C_1$ is equal to the angle POP_1 between the perpendiculars. To calculate it we first find the direction cosines (l, m, n) and (l_1, m_1, n_1) of OP and OP_1 .

Then $\cos \theta = ll_1 + mm_1 + nn_1$, and hence θ may be found.

EXAMPLE.—Find the angle between the two planes A, B, C , and A_1, B_1, C_1 , where, with the usual notation,

$$a = 2, b = 1, c = 1; a_1 = 2.5, b_1 = 2, c_1 = 3$$

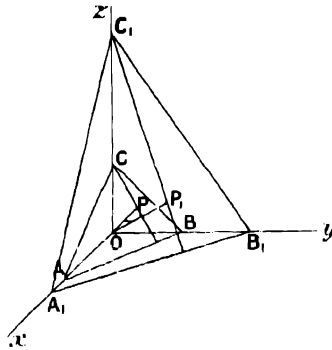

FIG. 170.

We have

$$OP = p = \frac{1}{\sqrt{\frac{1}{a^2} + \frac{1}{b^2} + \frac{1}{c^2}}} = \frac{2}{3}$$

$$l = \frac{p}{a} = \frac{1}{3}, m = \frac{p}{b} = \frac{2}{3}, n = \frac{p}{c} = \frac{2}{3}$$

$$OP_1 = p_1 = \frac{1}{\sqrt{\frac{1}{a_1^2} + \frac{1}{b_1^2} + \frac{1}{c_1^2}}} = 1.386$$

$$l_1 = \frac{p_1}{a_1} = \frac{1.386}{2.5} = 0.554, m_1 = \frac{p_1}{b_1} = 0.693, n_1 = \frac{p_1}{c_1} = 0.462$$

$$\therefore \cos \theta = ll_1 + mm_1 + nn_1 = 0.185 + 0.462 + 0.308 = 0.955 = \cos 17.4^\circ$$

\therefore angle between the planes = $POP_1 = 17.4^\circ$.

EXAMPLES.—CIII.

1. With the same notation as before,

$$a = 8, b = 3, c = 4; a_1 = 9, b_1 = 6, c_1 = 9$$

Find the angle between the two planes. Draw a figure in parallel projection to scale.

2.

$$a = 10, b = 5, c = 6; a_1 = 4, b_1 = 5, c_1 = 3$$

Find the angle between the two planes, and draw a figure to scale.

CHAPTER XXIV

VOLUMES OF SOLIDS

197. Volume of any Solid.—Consider the case of a solid in which the cross-sectional area perpendicular to a fixed axis in the solid follows some known law, as we pass from point to point along that axis.

We may, for instance, know the way in which the area of the horizontal section or water-plane of a ship varies from point to point along an axis drawn vertically from the keel.

Let A be the area of the water-plane of a ship when the keel is x feet below the surface, and let V be the displacement, *i.e.* the volume under water.

Suppose the ship to sink deeper into the water by a further small distance δx .

Then the displacement is increased by a thin plane layer of water of area A and thickness δx ; *i.e.* if δV is the increase in the displacement

$$\delta V = A\delta x$$

But we may imagine that the whole displacement V to any draught h is made up of a number of such thin layers of volume $\delta V = A\delta x$, and, therefore, the whole displacement V is the sum of the terms $A\delta x$ from $x = 0$ to $x = h$.

In the limit, as x is made smaller and smaller, this sum becomes $\int_0^h A dx$.

$$\therefore V = \int_0^h A dx$$

In the same way it can be shown in the general case that, if A is the cross-sectional area of any solid measured perpendicular to a fixed axis in the solid and at distance x from a fixed point on that axis, then the volume of the solid enclosed between two sections at $x = a$ and $x = b$ is $\int_a^b A dx$.

In order to find this integral we must know the law connecting A and x .

This law may be given by an equation, or by an empirical series of corresponding values. In the latter case the integral must be found by the graphic method.

EXAMPLE.—*The following table gives the area A of cross sections perpendicular to the length of a piece of timber at distances x from one end. Find the volume of the timber as accurately as you can from the given data.* ♡

x feet . .	0	6	15	23	30
A square feet	4.17	6.15	7.96	8.47	8.75

We have shown that the volume $V = \int_0^{30} A dx$.
 Plotting A and x we get the curve PQ .

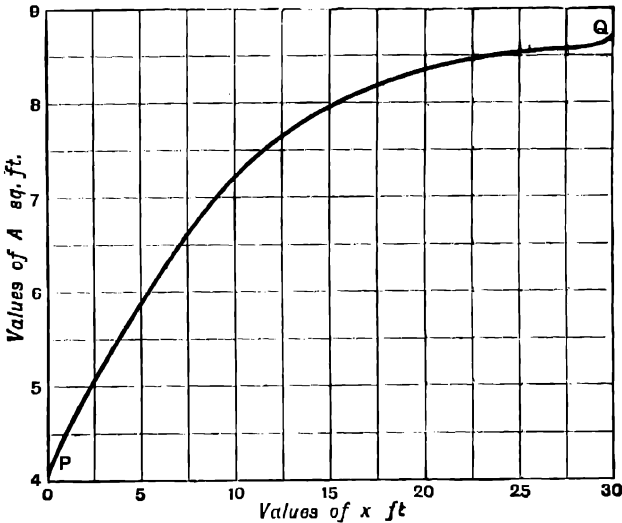

FIG. 171.

The required definite integral is the area between this curve and the axis of x . This is found to be 222.3.

$$\therefore V = 222.3 \text{ cub. ft.}$$

EXAMPLES.—CIV.

1. The following are values of the area in square yards of the cross section of a railway cutting taken at intervals of 6 ft. How many cubic feet of earth must be removed in making the cutting between the two end sections given?

70, 88, 94, 93, 87, 76

2. A is the cross-sectional area of a piece of oak at distance x from one end. Find its weight. One cubic foot of oak weighs 48 lbs.

x feet . .	0	2	4	6	8	10
A square feet	1.7	2.3	2.9	3.7	4.9	5.5

3. h is the height in feet of the surface of the water in a reservoir above the lowest point at the bottom. The reservoir is filled to various heights, and the area A measured as follows:—

h feet	0	14	24	36	76	96	110	120
A sq. ft.	0	21000	33000	36700	42000	44500	52500	60500

How many gallons of water does the reservoir hold when full to a depth of 120 ft.? Also, how much water leaves the reservoir when the surface level changes from 120 ft. to 60 ft.? 1 gallon = 0.16046 cub. ft.

4. A is the area of the surface of the water in a reservoir when full to a depth h .

h feet	60	50	40	30
A , square feet	37100	25900	16700	9500

The depth is originally 60 ft.; water is pumped out of the reservoir to a height of 100 ft. above the bottom until the depth is 30 ft.

Find the work done = $\int_{60}^{30} wA(100 - h)dh$; where w = weight of 1 cub. ft. of water = 62.3 lbs.

5. A is the area of the surface of the water in a reservoir when full to a depth h .

h feet	0	15	25	35	45
A square feet	2000	4500	20000	30000	50000

How much water does the reservoir hold when full? Construct a table showing the supply of water in the reservoir for different values of the depth at intervals of 5 ft. from 20 ft. to 45 ft.

6. A is the area of the water plane of a vessel at a distance x above the keel.

x feet	2	4	6	8	10
A square feet	2690	3635	4320	4900	5400

Find the total displacement of the vessel for a draught of 10 ft.

The displacement in tons is equal to the weight of the vessel; what weight is put into the vessel when the draught increases from 7 ft. to 10 ft. 1 ton of sea water measures 35 cub. ft.

7. The area of the water-plane of a certain vessel is found to vary as $h^{1.02}$, where h is the distance above the keel. When h is 20 ft. the area of the water-plane is 4810 sq. ft. Find the total displacement in cubic feet for a draught of 20 ft.

198. A surface of revolution is generated when a plane figure rotates about an axis in its plane.

E.g. a cone or cylinder is formed when a straight line rotates about an axis in its plane ; a sphere when a circle rotates about a diameter ; a paraboloid of revolution when a parabola rotates about its axis.

The rotating curve which traces out the surface is called the generating curve.

The section of a surface of revolution by any plane perpendicular to its axis is a circle.

199. Volume of a Solid of Revolution.—Let the curve PQ represent y as a function of x from $x = OA = a$ to $x = OB = b$.

Let PQ and the ordinates AP, BQ, rotate about the axis of x , so as to generate a surface of revolution whose section by the plane OXY is PQSR.

To find the volume of the solid enclosed by this surface, suppose the solid cut into thin circular discs by planes perpendicular to OX.

The area of any section is πy^2 , and its volume $\pi y^2 \delta x$, where δx is the thickness of the disc, and y the ordinate at some point within it.

The whole volume of the solid is thus the sum of a number of terms of the form $\pi y^2 \delta x$, which we write

$$\sum_a^b \pi y^2 \delta x$$

Now suppose the number of sections into which the solid is cut up to be indefinitely increased, and the thickness δx of each section to be indefinitely diminished. Then the limit of the sum $\sum_a^b \pi y^2 \delta x$ is

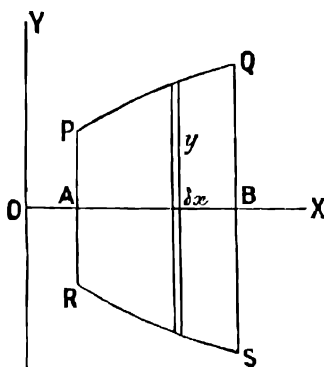

FIG. 17a.

$$\int_a^b \pi y^2 dx \quad (\S 130)$$

Thus, if a curve representing y as a function of x rotates about the axis of x , so to trace out a surface of revolution, the volume enclosed by this surface between the sections at $x = a$ and $x = b$ is

$$\int_a^b \pi y^2 dx$$

If the equation connecting y and x is known, the volume may in many cases be found by integration ; and if the form of the curve is known, the volume may always be found by graphic integration by the method of Chapter XVII.

200. We shall first consider examples of solids of revolution where the equation to the generating curve is known.

EXAMPLE (1).—To find the volume of a right circular cone, having given the height h and the radius a of the base.

The cone is formed by the revolution of a straight line OA about an axis OH . In the figure, $OH = h$, $HA = a$.

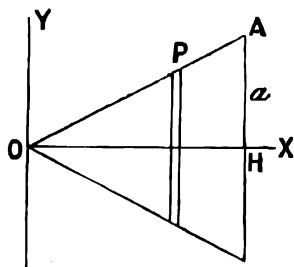

FIG. 173.

Take OH as axis of x . Then, if (x, y) are the co-ordinates of any point P on OA ,

$$\frac{y}{x} = \frac{a}{h} \text{ and } y = \frac{ax}{h}$$

The volume of a circular disc of thickness δx and radius y is $\pi y^2 \delta x$.

\therefore volume of cone = limit of the sum of such discs as δx is made smaller and smaller.

$$\begin{aligned} &= \int_0^h \pi y^2 dx = \int_0^h \pi \frac{a^2 x^2}{h^2} dx \\ &= \frac{\pi a^2}{h^2} \left[\frac{x^3}{3} \right]_0^h = \frac{1}{3} \pi a^2 h \\ &= \frac{1}{3} (\text{area of base}) \times (\text{height}) \end{aligned}$$

EXAMPLE (2).—The curve $y = \frac{1}{3}x^3$ revolves about the axis of y . Find the volume of the solid thus formed between the sections where $y = 1$ and $y = 3$.

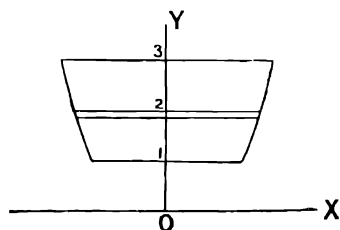

FIG. 174.

We here suppose the solid divided into circular elements of thickness δy and radius x by planes perpendicular to the axis of y .

We have $y = \frac{1}{3}x^3$, $x = (3y)^{\frac{1}{3}}$.

Then the volume of an element = $\pi x^2 \delta y$, and the whole volume of the figure =

$$\begin{aligned} &\int_1^3 \pi x^2 dy \\ &= \int_1^3 \pi (3y)^{\frac{2}{3}} dy \\ &= \pi \cdot 3^{\frac{2}{3}} \cdot \frac{3}{5} \left[y^{\frac{5}{3}} \right]_1^3 \\ &= \frac{3^{\frac{5}{3}} \pi}{5} \{ 3^{\frac{5}{3}} - 1 \} \\ &= 20'55 \end{aligned}$$

EXAMPLE (3).—Find the volume of a sphere of radius a .

Take two perpendicular diameters, OA and OB , as axes.

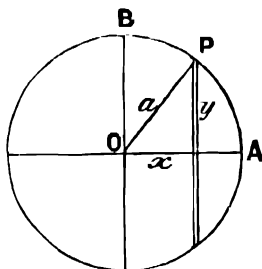

FIG. 175.

Then the sphere is generated by the revolution of the circle **APB** about the axis of x .

If (x, y) are the co-ordinates of any point **P**, on the circle, $x^2 + y^2 = a^2$.

Divide the sphere into thin circular elements of thickness, δx and radius y by planes perpendicular to the axis of x .

Then the volume of an element = $\pi y^2 \delta x$.

$$\begin{aligned} \text{Volume of sphere} &= \int_{-a}^{+a} \pi y^2 dx \\ &= \int_{-a}^{+a} \pi (a^2 - x^2) dx \\ &= \pi \left[a^2 x - \frac{x^3}{3} \right]_{-a}^{+a} \\ &= \pi \left(2a^3 - \frac{2a^3}{3} \right) = \frac{4}{3} \pi a^3 \end{aligned}$$

EXAMPLE (4).— Find the volume of the frustum of a sphere of radius 3 inches lying between two parallel planes on opposite sides of the centre, and at distances 1 and 2 inches respectively from the centre.

Take the centre as origin, the diameter perpendicular to the two end sections as axis of x , and any diameter perpendicular to this as axis of y .

Then the frustum is formed by the revolution of an arc of a circle about Ox .

The limiting values of x are -1 and 2 , and it follows, as in the previous example, that

$$\begin{aligned} \text{Volume} &= \int_{-1}^{+2} \pi y^2 dx \\ &= \int_{-1}^{+2} \pi (9 - x^2) dx \\ &= 9\pi \int_{-1}^{+2} dx - \pi \int_{-1}^{+2} x^2 dx \\ &= 27\pi - 3\pi \\ &= 75.4 \text{ cubic inches} \end{aligned}$$

EXAMPLE (5).— Prove the formula for the volume of the frustum of a cone.

$$\frac{\pi}{3} \cdot h(a^2 + ab + b^2)$$

Let the trapezium **ABCD** rotate about **AB**, so as to generate a frustum of a cone.

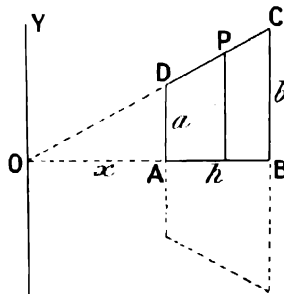

• FIG. 176.

Produce **CD** and **BA** to meet at **O**.

Take **O** as origin, **OA** as axis of x , and a straight line parallel to **BC** as axis of y .

Let **OB** = h_1 , **OA** = h_2 , **BC** = b , **AD** = a , **AB** = h .

Then at any point **P** (x, y) on **CD**

$$\frac{y}{x} = \frac{b}{h_1}, \text{ and } y = \frac{bx}{h_1}$$

$$\text{also } a = \frac{bh_2}{h_1}$$

$$\begin{aligned} \text{Volume of frustum} &= \int_{h_2}^{h_1} \pi y^2 dx \\ &= \int_{h_2}^{h_1} \pi \frac{b^2 x^2}{h_1^2} dx = \frac{\pi b^2}{h_1^2} \left(\frac{h_1^3 - h_2^3}{3} \right) \\ &= \frac{\pi}{3} (h_1 - h_2) \left(\frac{b^2 h_2^2}{h_1^2} + \frac{b^2 h_1 h_2}{h_1^2} + \frac{b^2 h_1^2}{h_1^2} \right) \\ &= \frac{\pi}{3} \cdot h \cdot (a^2 + ab + b^2) \end{aligned}$$

EXAMPLES.—CV.

1. Find by integration the volume of a cone having radius of base 3 ins., height 4 ins.

2. Find by integration the volume of the frustum of a cone, the radii of the two ends being 2 ins. and 4 ins. respectively, and the height 3 ins.

3. The curve $y = \frac{1}{3}x^3$ rotates about the axis of x . Find the volume of the portion of the solid of revolution generated which lies between the origin and the section at $x = 3$.

4. The parabola $y = 2\sqrt{x}$ rotates about the axis of x . Find the volume of the paraboloid of revolution generated between the origin and the section at $x = 4$.

5. A sphere of radius 6 ins. is cut by two parallel planes on opposite sides of the centre at distances 4 ins. and 1 in. from the centre. Find the volumes of the frustum between the two sections, and of the smaller segment cut off from the sphere by the plane at a distance of 4 ins. from the centre.

NOTE.—Do not use the formula, but perform the integration in full.

6. Find the volume of a frustum of a sphere of radius 4 ins., which is cut off by two parallel planes on opposite sides of the centre, and distant 3 ins. from the centre.

7. Prove the formula, given in § 44, for the volume of a zone of a sphere.

8. The ellipse $\frac{x^2}{16} + \frac{y^2}{9} = 1$ rotates about the axis of x . Find the volume of the ellipsoid of revolution which it generates.

9. The curve $y = x^2 - 2x + 2$ rotates about the axis of x . Find the volume of the solid of revolution generated between the sections at $x = 0$ and $x = 2$.

10. The curve $y = ce^{mx}$ rotates about the axis of x . Find the volume enclosed by the surface of revolution generated and the sections at $x = a$ and $x = b$. Given $y = m$ when $x = a$; a, b, m , and n are known constants.

11. The figure formed by the curve $y = 4x^2$, the axis of y , and the straight line $y = 4$ rotates about the axis of y . Find the volume of the solid of revolution generated.

201. Graphic Determination of Volumes enclosed by Surfaces of Revolution.—Instead of having the equation to the generating curve given as in the above examples, we may have the form of the curve given by a list of tabulated values.

The volume enclosed by the surface $= \int_a^b \pi y^2 dx$ may then be found by a graphic method.

EXAMPLE.—The following are corresponding values of y and x for a certain curve. This curve rotates about the axis of x so as to generate a surface of revolution. Find the volume enclosed by this surface and the two end sections, where $x = 2.4$ and $x = 10.6$.

x inches	2.4	4.6	7	9.4	10.6
y inches	1.55	2.13	2.32	1.65	0

Plotting these values of y and x , we get the curve PQ.

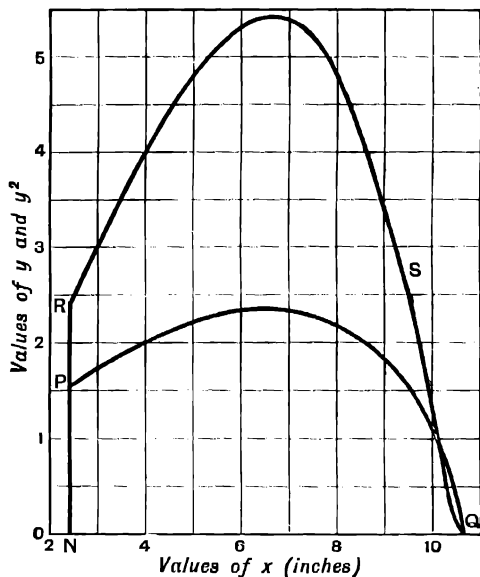

FIG. 177.

The volume enclosed by the surface of revolution generated by the rotation of this curve and the ordinate NP about the axis of x is $\int_{2.4}^{10.6} \pi y^2 dx$

$$= \pi \int_{2.4}^{10.6} y^2 dx$$

Taking values of y from the curve PQ, squaring them, and plotting, we get the curve RS representing y^2 as a function of x . The area between this curve and the axis of x from $x = 2.4$ to $x = 10.6$ is found by Simpson's rule to be 32.16. This is the value of $\int_{2.4}^{10.6} y^2 dx$.

∴ the required volume of the surface of revolution is

$$\pi \int_{2.4}^{10.6} y^2 dx = \pi \times 32.16 = 101 \text{ cub. ins.}$$

In practice it is not necessary actually to draw the curve **RS**. In the formula for Simpson's rule we may substitute the values of the squares of the ordinates taken from the curve **PQ** at the proper intervals. The result will give the area under the curve **RS**, which is equal to $\int y^2 dx$.

The student should, however, in working the first few examples, draw both curves as in the above examples, until he has become familiar with the method.

EXAMPLES.—CVI.

The curves given by the following lists of values of x and y rotate about the axis of x . Find the volumes of the solids of revolution which they generate between the specified limits.

1.

x inches	2	3	4	5	6	7	8
y inches	5'15	5'54	5'63	5'46	4'80	3'86	3'16

Between $x = 2$ and $x = 8$.

2.

x inches . .	0	10	15	20	25
y inches . .	10	6'93	7'21	9'80	15'03

Between $x = 0$ and $x = 25$.

3.

x inches	0	1	1'5	2	2'5	3	3'5	4'0
y inches	0'5	0'9	1'05	1'17	1'24	1'2	1'05	0'8

Between $x = 0$ and $x = 4$.

4.

x inches . .	1'99	2'80	3'412	3'919	4'359	4'75
y inches . .	1'8	1'6	1'4	1'2	1	0'8

Between $x = 2$ and $x = 4'5$.

5.

x feet .	0'5	1'4	2	2'7	3'5	4'2	4'6	5'3	6
y inches	12'37	12'78	12'62	11'78	10'89	10'56	10'45	10'69	12'04

Between $x = 0'5$ and $x = 6$.

6. A buoy is in the form of a solid of revolution floating with its axis vertical, d is its diameter at depth h below the surface of the water. Find the weight of water displaced by the buoy. One cubic foot of sea water weighs 64·11 lbs.

Depth below water-line (feet)	0	0·6	0·9	1·25	1·50	1·80	2
Diameter (feet)	6	5·90	5·8	5·55	5·25	4·70	4·20

The bottom of the buoy is flat, and at a depth of 2 ft.

CHAPTER XXV

CENTRES OF GRAVITY

202. IN Chapter XXI. we defined the centre of gravity of a number of weights supposed concentrated at isolated points, and obtained expressions for its position.

If (\bar{x}, \bar{y}) are the co-ordinates of the centre of gravity of weights m_1, m_2, m_3, \dots situated at the points $(x_1, y_1), (x_2, y_2), (x_3, y_3), \dots$ then

$$\bar{x} = \frac{m_1x_1 + m_2x_2 + m_3x_3 + \dots}{m_1 + m_2 + m_3 + \dots} = \frac{\Sigma(mx)}{\Sigma(m)}$$

$$\bar{y} = \frac{m_1y_1 + m_2y_2 + m_3y_3 + \dots}{m_1 + m_2 + m_3 + \dots} = \frac{\Sigma(my)}{\Sigma(m)}$$

203. Centre of Gravity of Distributed Masses.—If any figure is cut out in a thin stiff uniform material, such as sheet metal or cardboard, there is a certain point in the plane of the figure through which its resultant weight always acts so that the figure will balance if supported only at this point.

In this sense we speak of the centre of gravity, or centre of mass, of a plane area. The position of the centre of gravity will evidently depend only on the shape of the figure, and not on its material, so that in finding the centre of gravity of a figure we may take the area of any portion as equal to its weight.

The centre of gravity of a figure is also known as the **centre of area**, or **centroid**.

In the same way every solid body has a centre of gravity through which the resultant weight always acts.

We may suppose the number of isolated masses enclosed in a given space to be indefinitely increased, and at the same time the magnitude of each mass to be diminished so that in the limit a continuous solid body is formed. Then the definition of the centre of gravity of a number of isolated weights may be extended to the case of a continuous solid body.

EXAMPLE.—Find the abscissa of the centre of gravity of the area given in the figure.

Divide the area into ten strips of equal width by straight lines parallel to the axis of y .

Take the weight of each strip as numerically equal to its area, and assume this weight to act at the centre of gravity of the strip.

If the strips are sufficiently narrow, the centre of gravity of each strip may be supposed to lie on the ordinate drawn at the mid point of the base of that strip; e.g. in the figure the centre of gravity of the second strip is at G.

We now have, if (\bar{x}, \bar{y}) are the co-ordinates of the centre of gravity,

$$\bar{x} = \frac{\Sigma(mx)}{\Sigma(m)} \text{ approximately}$$

where m is the area of a strip, and x the abscissa of the mid point of its base.

$\Sigma(mx)$ is obtained by multiplying the base of each strip by its mean height to get the area, and then multiplying the result by the abscissa of the mid point of the base, and adding the results.

$\Sigma(m)$ is the whole area of the figure.

$$\therefore \Sigma(mx) = \frac{62.96}{30.64} = 2.05$$

\therefore the centre of gravity lies in the ordinate AB.

Similarly, the ordinate y of the centre of gravity may be found by dividing the area into strips parallel to Ov .

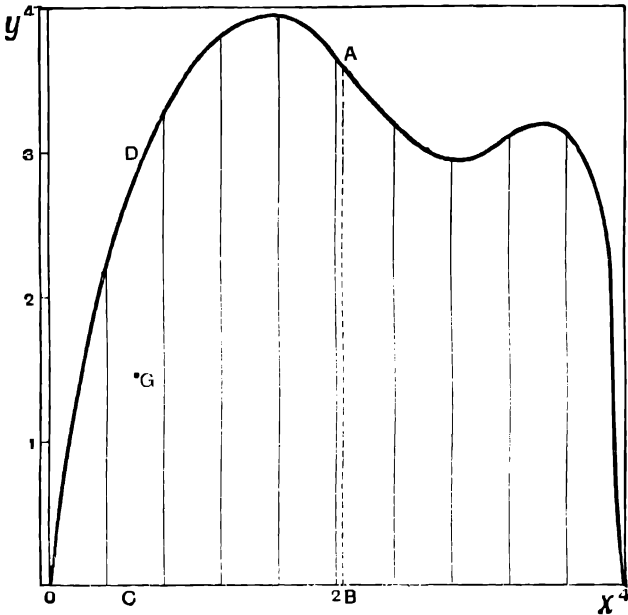

FIG. 178.

204. Centre of Gravity of an Area by Integration.—The accuracy of the method described in the last paragraph depends on the number of strips into which we divide the area. If the area is divided into 20 parts instead of into 10, the resulting value of \bar{x} will be nearer to the exact value of the abscissa of the centre of gravity, and so on.

If δx is the width and y the mean height of a strip, then the area of that strip, which is proportional to its mass, is $y\delta x$, and

$$\bar{x} = \frac{\Sigma(xy\delta x)}{\Sigma(y\delta x)} \text{ approximately}$$

The exact value of \bar{x} is the limiting value of this expression, as the number of divisions is indefinitely increased, *i.e.* when δx is indefinitely diminished.

$$\therefore \bar{x} = \frac{\int_a^b xy dx}{\int_a^b y dx}$$

where a and b are the limiting values of x for the area considered.

Similarly, since the ordinate of the centre of gravity of a strip is $\frac{y}{2}$, we have

$$\bar{y} = \frac{\sum\left(\frac{y}{2} \cdot y \cdot \delta x\right)}{\sum(y \delta x)}$$

and in the limit

$$\bar{y} = \frac{\frac{1}{2} \int_a^b y^2 dx}{\int_a^b y dx}$$

Thus, if the equation to the bounding curve is known, we may be able to evaluate these integrals, and so find the position of the centre of gravity.

EXAMPLE (1).—Find the centre of gravity of a triangle.

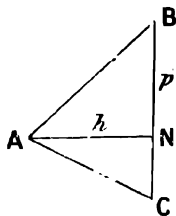

FIG. 179.

In the triangle ABC draw AN perpendicular to BC . Take A as origin of rectangular co-ordinates, and AN as axis of x .

Let $AN = h$, $BN = p$.

First find the centre of gravity of the triangle ANB .

Then the equation to the straight line AB is $\frac{y}{x} = \frac{p}{h}$.

$$\begin{aligned} \therefore \bar{x} &= \frac{\int_0^h xy dx}{\int_0^h y dx} = \frac{\int_0^h \frac{px^2}{h} dx}{\int_0^h \frac{px}{h} dx} \\ &= \frac{\int_0^h x^2 dx}{\int_0^h x dx}, \text{ since } p \text{ and } h \text{ are constants,} \\ &= \frac{\frac{h^3}{3}}{\frac{h^2}{2}} \\ &= \frac{3}{h^2} \cdot \frac{h^3}{2} = \frac{3}{2}h \end{aligned}$$

Similarly, for the triangle ANC , $\bar{x} = \frac{2}{3}h$. It follows that $\bar{x} = \frac{2}{3}h$ for the whole triangle.

Similarly, the centre of gravity is at a distance of $\frac{2}{3}$ of the height measured from any other side of the triangle, and its position is completely determined.

EXAMPLE (2).—Find the centre of gravity of the area bounded by the parabola $y = 0.2x^2 + 1$, the axis of x , and the ordinates at $x = 3$ and $x = 5$.

We have

$$\begin{aligned}\bar{x} &= \frac{\int_3^5 xy dx}{\int_3^5 y dx} \\ &= \frac{\int_3^5 (0.2x^3 + x) dx}{\int_3^5 (0.2x^2 + 1) dx} \\ &= \frac{\left[\frac{x^4}{20} + \frac{x^2}{2} \right]_3^5}{\left[\frac{x^3}{15} + x \right]_3^5} = \frac{35.2}{8.53} = 4.125 \\ \bar{y} &= \frac{\frac{1}{2} \int_3^5 y^2 dx}{\int_3^5 y dx} \\ &= \frac{\frac{1}{2} \int_3^5 \left(\frac{x^4}{25} + \frac{2}{5}x^2 + 1 \right) dx}{8.53} \\ &= \frac{1}{17.06} \left[\frac{x^5}{125} + \frac{2}{15}x^3 + x \right]_3^5 = \frac{38.16}{17.06} = 2.24\end{aligned}$$

∴ the centre of gravity is at the point (4.125, 2.24).

The student should draw the figure to illustrate this example.

EXAMPLES.—CVII.

1. Find by integration the centre of gravity of an isosceles triangle, having its base 6 inches, and height 4 inches.

Find the centres of gravity of the areas bounded by the following curves, the axis of x , and the ordinates at the points specified:—

2. $y = x^{\frac{1}{2}}$ between $x = 0$ and $x = 1$.

3. $y = 2x^{\frac{1}{2}}$ between $x = 1$ and $x = 4$.

4. $y = x^{\frac{1}{3}}$ between $x = 0$ and $x = 1$.

5. $y = x^{\frac{1}{3}}$ between $x = 1$ and $x = 2$.

6. $y = \frac{1}{3}x^{\frac{1}{3}}$ between $x = 0$ and $x = 27$.

7. A trapezium is bounded by the ordinates h_1 at $x = a$, and h_2 at $x = b$, the axis of x , and the straight line joining the heads of the ordinates h_1 and h_2 . Find the co-ordinates of its centre of gravity by integration.

Find the abscissæ of the centres of gravity of the areas bounded by the following curves, the axis of x , and the ordinates at the points specified:—

8. $y = x + \sqrt{x}$ between $x = 0$ and $x = 1$.

9. $y = x^2 - 2x + 2$ between $x = 0$ and $x = 3$. Plot the curve.

10. Find the position of the centre of gravity of a semi-circle of radius a .

11. Find the position of the centre of gravity of the parabolic spandril bounded by the parabola $5 - y = 2\sqrt{x}$, and the axes of x and y .

205. Centre of Gravity of an Area—Graphic Method.—The graphic method may now be put into a more concise and accurate form than in § 203.

With the same notation as before, we have shown that

$$\bar{x} = \frac{\int_a^b xy dx}{\int_a^b y dx}, \quad \bar{y} = \frac{\int_a^b y^2 dx}{2 \int_a^b y dx}$$

If we do not know the equation of the bounding curve or cannot evaluate the above integrals, we may find their values by the graphic method.

EXAMPLE.—The following are corresponding values of x and y for a certain curve, find the abscissa of the centre of gravity of the area enclosed by this curve, the ordinates at $x = 1$ and $x = 5.3$, and the axis of x .

x	1	1.5	2	2.5	3	3.5	4	4.5	5	5.3
y	3.52	3.45	3.16	2.67	2.00	1.56	1.40	1.40	1.65	2.00

Plotting the given values of x and y we get the curve PQ.

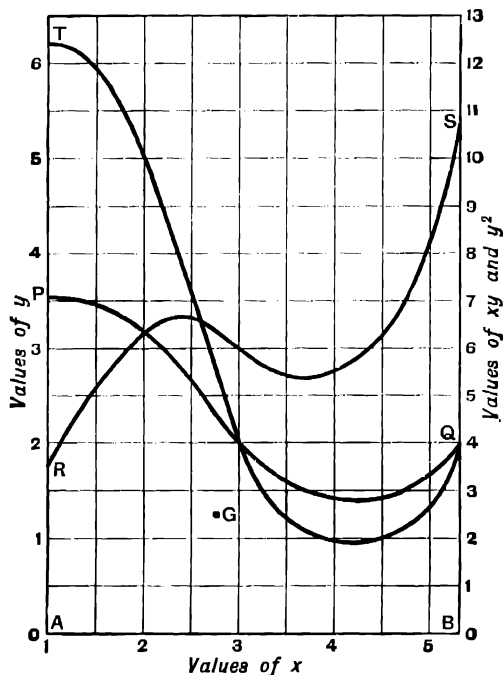

FIG. 18a.

We know that

$$\bar{x} = \frac{\int_1^{5.3} xy dx}{\int_1^{5.3} y dx}$$

The denominator is equal to the area PQBA, which is found to be 9.64.

To find the numerator we require to plot the values of xy .

Multiplying the given corresponding pairs of values of x and y we obtain the following values:—

xy	3.52	5.18	6.32	6.675	6.00	5.46	5.60	6.30	8.25	10.6
y^2	12.39	11.90	9.99	7.13	4.00	2.43	1.96	1.96	2.72	4.00

Plotting these values of xy we get the curve RS.

The area RSBA is found to be 26.44.

$$\therefore \int_1^{5.3} xy dx = 26.44$$

$$\text{and } \bar{x} = \frac{26.44}{9.64} = 2.74$$

Also we have

$$\bar{y} = \frac{\int_1^{5.3} y^2 dx}{\int_1^{5.3} y dx}$$

To find $\int_1^{5.3} y^2 dx$ we require to plot the values of y^2 . Calculating these as shown above, and plotting, we get the curve TQ.

The area TQBA is found to be 24.44

$$\therefore \bar{y} = \frac{24.44}{9.64} = 2.54$$

\therefore the centre of gravity is at the point G whose co-ordinates are 2.74, 2.54.

In practice the curves RS and TQ need not be drawn; the values of xy and y^2 necessary for the calculation of the integrals may be found from the curve PQ.

Note that this method of finding \bar{y} has only been shown to apply when the base of the area considered is the axis of x . To find \bar{y} in other cases we may divide the area into elements parallel to the axis of x ; \bar{y} is then given by the relation

$$\bar{y} = \frac{\int_c^d xy dy}{\int_c^d x dy}$$

where c and d are the limiting values of y , and x denotes the width of the figure measured parallel to the axis of x .

EXAMPLES.—CVIII.

1. A curve passes through the following points. Find the abscissa of the centre of gravity of the area enclosed by this curve, the ordinates at $x = 0.5$ and $x = 6.5$, and the axis of x .

x	0·5	1·2	2·3	3·2	4·5	5·4	6·1	6·5
y	5·0	3·6	2·7	2·45	2·34	2·43	2·6	2·75

2. The height of a certain figure is measured at different points along the axis of x , as given in the following table. Find the abscissa of its centre of gravity.

x	0·3	1	1·5	2·0	2·6	3·2	3·5	4·0	4·4	5·0	5·3
y	0	0·42	0·585	0·76	1·055	1·53	2·4	2·19	1·92	1·15	0

3. Plot a curve from the following values of x and y . Find the abscissa of the centre of gravity of the area enclosed by this curve, the line $y = 10$, and the ordinates $x = 20$ and $x = 40$.

x	20	26	30	32·5	36	38	40
y	30·3	46·1	58	65·9	77·6	84·6	91·9

4. Find the co-ordinates of the centre of gravity of the area enclosed by the curve given by the following values, the ordinates at $x = 3·1$ and $x = 5·2$, and the axis of x :—

x	3·10	3·56	4·1	4·85	5·20
y	22·47	19·19	15·97	12·85	11·72

5. Find the co-ordinates of the centre of gravity of the area within the closed curve, which passes through the following points in the order given :—

x	1·1	1·8	2·6	3·8	4·4	5·2	5·35	5·1	4·3	3·1	2·0	1·2	0·7	0·6	1·1
y	1·0	0·3	0·08	0·40	0·7	1·7	2·6	3·75	5·17	5·83	5·5	4·6	3·25	2·1	1·0

6. Find by the graphic method the position of the centre of gravity of the quadrant of a circle of radius 4 ins. Also find the centre of gravity by experiment, and compare the results.

7. The equation to half of an ellipse is $y = \sqrt{1 - 0·25x^2}$. Plot this curve, and find by the graphic method the centre of gravity of the area enclosed between this curve and the axis of x .

8. ABCD is the section of a bar. AB, BC, CD are three adjacent sides of a regular hexagon. AD measures 1 ft. Find by the graphic method the position of the centre of gravity of the section.

206. Centre of Gravity of a Curve.

EXAMPLE.—The curve shown in the figure represents a thin uniform wire. Find the position of its centre of gravity.

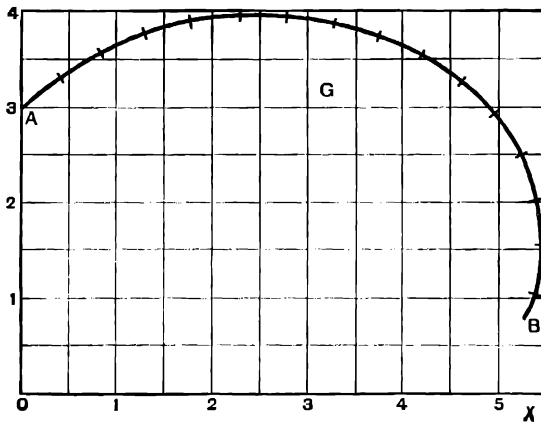

FIG. 231.

Divide the curve into small elements of some convenient length. Then each element is approximately a short straight rod, and its centre of gravity is situated at its mid point.

In this case we divide the curve into elements $\frac{1}{4}$ in. long. Take the mass of each $\frac{1}{4}$ in. element as the unit of mass. The length of the last element at B is 0.115 in., and its mass is therefore 0.46.

Take any convenient axes of x and y . Then, since

$$\bar{x} = \frac{\Sigma(mx)}{\Sigma(m)}, \quad \bar{y} = \frac{\Sigma(my)}{\Sigma(m)}$$

We shall obtain the approximate position of the centre of gravity by the following method:—

Multiply the mass of each element by the value of x at its mid point, and add the products obtained. Divide the sum by the total mass of the curve. The result is the abscissa of the centre of gravity. In the same way the ordinate of the centre of gravity may be found.

Substituting the values from the curve, we find

$$\begin{aligned} \bar{x} &= \frac{\Sigma(mx)}{\Sigma(m)} = \frac{51.28}{15.46} = 3.32 \\ \bar{y} &= \frac{\Sigma(my)}{\Sigma(m)} = \frac{48.26}{15.46} = 3.12 \end{aligned}$$

Thus the centre of gravity is at the point G (3.32, 3.12) in the figure.

EXAMPLES.—CIX.

1. Plot a curve from the following values of x and y . Find the co-ordinates of the centre of gravity of a uniform wire bent into this shape, the ends of the wire being at the points (0.7, 3.54) and (5, 6).

x	0.7	1.3	2.0	2.6	3.4	4.0	5.0
y	3.54	4.35	5.0	5.4	5.75	5.91	6.0

2. A curve passes through the following points in the order given. Find the position of its centre of gravity.

x	19	17	17	21	26	36	45	48	50	53	62.6	66	67.7	61
y	10	20	29	38	43	45	38.5	33.5	27	18	15	18	24	31

3. Find the position of the centre of gravity of the perimeter of the figure in example cviii. 5.

4. Find by the graphic method the position of the centre of gravity of the arc of a semicircle of radius 4 inches.

5. Draw an arc of a circle of radius 10 inches, subtending a chord of length 5 inches. Find the distance of the centre of gravity of the arc from the curve.

207. Centre of Gravity of a Solid of Uniform Density.

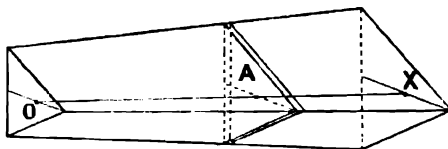

FIG. 18a.

Take a fixed axis of x in the body. Divide the body into thin plates by a series of planes perpendicular to the axis of x .

Let δx be the thickness of any plate and A its area. Then its volume, which is proportional to its mass, is $A\delta x$. And

$$\bar{x} = \frac{\sum(Ax\delta x)}{\sum(A\delta x)} \text{ approximately}$$

the values of x in the numerator being measured to some point within the corresponding thin plate.

In the limit, as δx is diminished and the number of divisions increased, this becomes

$$\bar{x} = \frac{\int_a^b Ax dx}{\int_a^b A dx}$$

where a and b are the values of x for the two end sections.

The law connecting A and x may be given by means of an equation or by an empirical series of values obtained by measurement at various points along the axis. In the latter case the above integrals may be found by a graphic method.

EXAMPLE.—The cross-sectional area A of a certain body of uniform density is measured at right angles to a fixed axis in the body, x is the distance of a section from a fixed point on this axis.

The following table gives corresponding values of A and x . Find the value of \bar{x} at the centre of gravity of the body.

x	1	1.4	2	3	4	5	6	7
A	0	2.5	4.25	5	5	4.8	4.33	3.86

We have
$$\bar{x} = \frac{\int_1^7 Ax dx}{\int_1^7 A dx}$$

Plotting A and x we get the curve PQ.

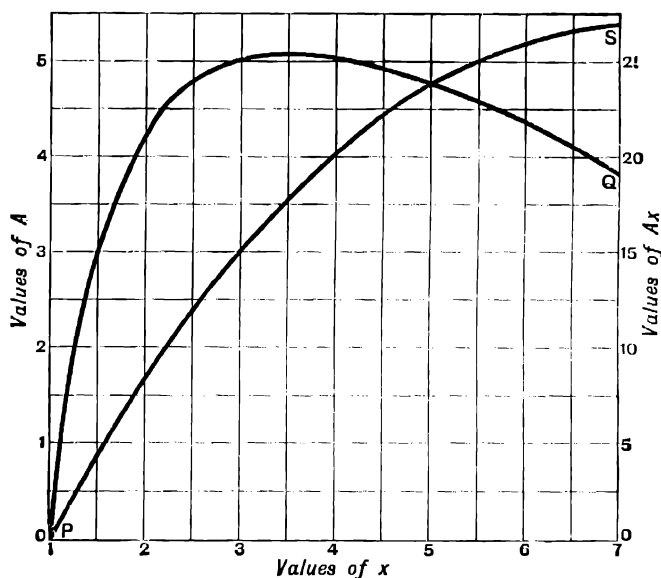

FIG. 183.

The value of $\int_1^7 A dx$ is the area between this curve and the axis of x .

This is found to be 26.2.

To find the value of the numerator we require to plot the values of Ax and x .

Multiplying the given values of A and x in pairs we get the values of Ax as follows:—

x	1	1.4	2	3	4	5	6	7
Ax	0	3.5	8.5	15	20	24	26	27

Plotting these values we get the curve **PS**.

Then the value of $\int_1^7 Ax dx$ is the area between **PS** and the axis of x .

This is found to be 107.7.

$$\therefore \bar{x} = \frac{107.7}{26.2} = 4.11$$

i.e. the centre of gravity is situated in that section of the solid for which $x = 4.11$.

208. Centre of Gravity of a Solid of Revolution.—This is a special case of the last method.

The sections of the solid by planes perpendicular to the axis of revolution are circles. Let the solid be cut by such planes into thin circular discs of thickness δx and radius y , then $A = \pi y^2$, and we have

$$\bar{x} = \frac{\int_a^b Ax dx}{\int_a^b A dx} = \frac{\int_a^b y^2 x dx}{\int_a^b y^2 dx}$$

EXAMPLE (1).—Find the centre of gravity of a solid hemisphere.

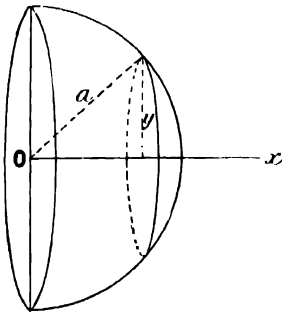

FIG. 184.

Let a be the radius of the hemisphere. Take the centre as origin and the radius perpendicular to the plane surface as axis of x .

Then the hemisphere is a solid of revolution formed when the quadrant of a circle of radius a revolves about the axis of x .

$$\therefore \bar{x} = \frac{\int_0^a y^2 x dx}{\int_0^a y^2 dx}$$

where (x, y) are the co-ordinates of any point on the generating curve.

But we have $x^2 + y^2 = a^2$, and \therefore , substituting $y^2 = a^2 - x^2$ in the above,

$$\begin{aligned} \bar{x} &= \frac{\int_0^a (a^2 x - x^3) dx}{\int_0^a (a^2 - x^2) dx} \\ &= \frac{\left[\frac{a^2 x^2}{2} - \frac{x^4}{4} \right]_0^a}{\left[a^2 x - \frac{x^3}{3} \right]_0^a} = \frac{\frac{a^4}{2} - \frac{a^4}{4}}{\frac{2a^3}{3}} \\ &= \frac{3}{8} a \end{aligned}$$

The centre of gravity of a solid hemisphere is on the axis at a distance of $\frac{3}{8}$ of the radius from the centre.

EXAMPLE (2).—The curve $y = 3 + \frac{4}{x}$ revolves about the axis of x so as to generate a solid of revolution. Find the centre of gravity of the portion of this solid which lies between the sections at $x = 2$ and $x = 4.8$.

We have

$$\begin{aligned} \bar{x} &= \frac{\int_2^{4.8} xy^2 dx}{\int_2^{4.8} y^2 dx} \\ &= \frac{\int_2^{4.8} \left(9x + 24 + \frac{16}{x}\right) dx}{\int_2^{4.8} \left(9 + \frac{24}{x} + \frac{16}{x^2}\right) dx} \\ &= \frac{\left[9 \cdot \frac{x^2}{2} + 24x + 16 \log_e x\right]_2^{4.8}}{\left[9x + 24 \log_e x - \frac{16}{x}\right]_2^{4.8}} \\ &= \frac{165.9}{31.97} = 5.19 \end{aligned}$$

Since the body is symmetrical with respect to the axis of x , we also know that the centre of gravity lies on the axis of x , and its position has been completely determined.

EXAMPLES.—CX.

1. Find the centre of gravity of the cone formed by the straight line $y = \frac{1}{2}x$ rotating about the axis of x , the base of the cone being a plane perpendicular to Ox at the point $x = 6$.

2. Find the centre of gravity of the frustum of the cone in example 1, which lies between the sections at $x = 3$ and $x = 6$.

3. Prove that the centre of gravity of a right circular cone of height h lies at a distance $\frac{3}{4}h$ from the vertex.

4. The radii of the ends of a frustum of a cone are 3 and 7 ins. respectively, and its height is 9 ins. Find the distance of its centre of gravity from the smaller end.

5. Find the position of the centre of gravity of the frustum of a sphere of radius 5 ins. The radii of the plane faces are 4 and 3 ins.

6. The curve $y = x^2 - 2x + 2$ rotates about the axis of x . Find the centre of gravity of the solid of revolution generated between the sections at $x = 0$ and $x = 3$.

7. The parabola $y = 16\sqrt{x}$ rotates about the axis of x . Find the position of the centre of gravity of the paraboloid of revolution which is generated between $x = 0$ and $x = 16$.

8. Find the centre of gravity of the portion of the same paraboloid lying between sections at $x = 4$ and $x = 9$.

209. Centre of Gravity of a Solid of Revolution—Graphic Method.

EXAMPLE.—The curve given by the following values of x and y revolves about the axis of x . Find the centre of gravity of the solid of revolution which it generates between the end sections at $x = 3$ and $x = 9$.

x	3	3.7	4.3	5	5.5	6.3	7	7.5	8	8.6	9
y	1	1.10	1.19	1.30	1.395	1.60	1.85	2.10	2.43	2.925	3.35
y^2	1	1.21	1.42	1.69	1.95	2.56	3.42	4.41	5.90	8.55	11.22
xy^2	3	4.5	6.1	8.4	10.7	16.1	23.9	33.0	47.2	73.6	101

We have

$$\bar{x} = \frac{\int_3^9 xy^2 dx}{\int_3^9 y^2 dx}$$

Calculating the values of y^2 , as shown in the third line above, and plotting, we get the curve PQ.

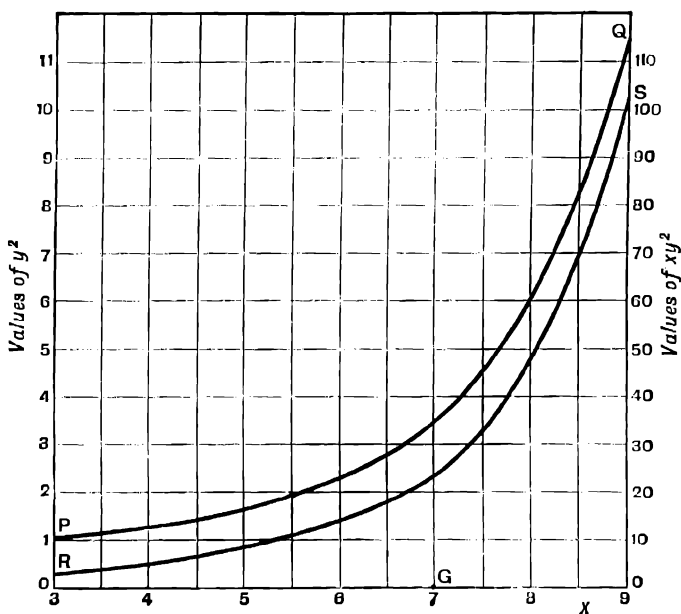

FIG. 185.

The area between this curve and the axis of x is found to be 20.1.

$$\therefore \int_3^9 y^2 dx = 20.1$$

Multiplying in pairs the corresponding numbers in the first and third lines, we get the values of xy^2 given in the fourth line.

Plotting these, we get the curve RS.

The area between this curve and the axis of x is found to be 142.5.

$$\therefore \int_3^9 xy^2 dx = 142.5$$

$$\therefore \bar{x} = \frac{142.5}{20.1} = 7.1$$

EXAMPLES.—CXI.

1. The curve given by the following values of y and x rotates about the axis of x . Find the position of the centre of gravity of the solid of revolution which it generates.

x	2	2.8	3.5	4.5	5.5	6.4	7.3	8.0
y	1	2.06	2.71	3.25	3.39	3.30	2.80	1.80

2. Find the position of the centre of gravity of the solid of revolution specified in Examples CVI., 1.

3. Find the position of the centre of gravity of a solid hemisphere of 5 inches radius by the graphic method, and compare with the result obtained by direct integration.

4. A is the area of the vertical cross-section of a solid at distance x from one end. Find the distance of the centre of gravity from that end.

x ft.	0	25	50	100	150	206	230	240	250
A sq. ft.	1	145	214	260	277	250	188	140	1

5. Find the centre of gravity of the water displaced by the buoy whose dimensions are given in Example CVI., 6.

210. Theorem of Pappus for the Volume of a Ring.—A closed figure rotates about an axis in its plane so as to generate a ring. To find the volume of the ring.

Divide the total area A of the rotating figure into small elements of area δA , and let x be the distance of any element from the axis of rotation PQ.

Then the element δA traces out a thin circular ring of radius x .

The volume of this ring is $2\pi x \delta A$, and the volume of the ring generated by the whole area A is the sum of the terms $2\pi x \delta A$ for all the elements δA .

But if we divide an area A into small elements and multiply each element by its distance x from an axis, the sum of the products is in the limit equal to $\bar{x} \cdot A$ (vide p. 297) where \bar{x} is the distance of the centre of gravity of the area from PQ.

\therefore the volume of the ring = $2\pi \bar{x} \cdot A$; i.e. it is equal to the area of the rotating figure multiplied by the circumference of the circle traced out by its centre of gravity.

In the same way it follows that if the area A does not rotate through a whole circle, the volume traced out is equal to the area A multiplied by the length of the path of its centre of gravity.

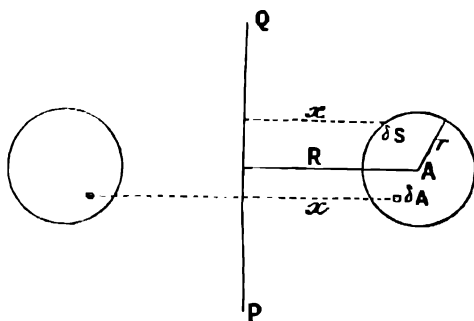

FIG. 186.

If A rotates through an angle θ radians, then the volume of the solid traced out is $\theta \cdot \bar{x} \cdot A$.

211. Theorem of Pappus for the Area of the Surface of a Ring.—

Let a closed curve of perimeter S rotate about an axis in its plane so as to generate a ring. To find the area of the surface of the ring.

Divide the perimeter S into small elements δS (Fig. 186).

Let x be the distance of δS from the axis of rotation PQ . Then δS traces out a ring whose area is $2\pi x \delta S$.

The whole area is therefore

$$2\pi \sum x \delta S = 2\pi \bar{x} S$$

where \bar{x} now refers to the centre of gravity of the perimeter S and not to the centre of gravity of the area A of the figure.

Thus the area of the surface of a ring is equal to the length of the generating curve multiplied by the length of the path traced out by its centre of gravity.

If S is not a closed curve this method gives the area of one side of the surface of revolution which it traces out.

NOTE.—These theorems are sometimes attributed to Guldin, who published them in the sixteenth century. They had, however, been previously discovered by Pappus in the third century, A.D.

EXAMPLE (1).—Find an expression for the volume and area of the surface of an anchor ring.

An anchor ring is generated when a circle rotates about an axis in its plane. Let r be the radius of the rotating circle, and R the radius of the circle traced out by its centre (Fig. 186).

$$\begin{aligned} \text{Then the area of the rotating circle} &= \pi r^2 \\ \text{Length of path of its centre of gravity} &= 2\pi R \\ \therefore \text{volume of anchor ring} &= 2\pi^2 R r^2 \end{aligned}$$

To find the area of the surface we have

$$\begin{aligned} \text{Perimeter of rotating curve} &= 2\pi r \\ \text{Length of path of its centre of gravity} &= 2\pi R \\ \therefore \text{area of surface of anchor ring} &= 4\pi^2 R \cdot r \end{aligned}$$

EXAMPLE (2).—*The curve whose centre of gravity was found in § 206, revolves about the axis of x so as to generate a surface of revolution. Find the area of this surface.*

We found that the length of the curve was 3·865 inches, and the ordinate of its centre of gravity was 3·12 half-inch units = 1·56 inches.

\therefore the centre of gravity traces out a circular path of radius 1·56 inches.
The area of the surface is

$$3\cdot865 \times 2\pi \times 1\cdot56 = 38\cdot5 \text{ square inches}$$

This is, of course, the area of one side only of the surface.

EXAMPLE (3).—*Find the centre of gravity of the arc of a semicircle, having given that the area of the surface of a sphere of radius r is $4\pi r^2$, and that the circumference of a circle of radius r is $2\pi r$.*

The sphere may be regarded as being generated by the revolution of a semicircle about a diameter.

If \bar{x} be the distance of the centre of gravity of the curve from the axis, the length of the path of the centre of gravity is $2\pi\bar{x}$.

Also length of curve = πr .

$$\begin{aligned} \therefore \text{Area of surface of sphere} &= \pi r \cdot 2\pi\bar{x} \\ \therefore 2\pi^2 r \bar{x} &= 4\pi r^2 \\ x &= \frac{2r}{\pi} = 0\cdot636r \end{aligned}$$

\therefore the centre of gravity of a semicircle is on the middle radius at a distance $\frac{2}{\pi}r = 0\cdot636r$ from the centre.

EXAMPLES.—CXII.

1. The mean radius of the rim of a cast-iron flywheel is 3 ft., width 9 ins., thickness, measured in direction of radius, 6 ins. Find its weight. 1 cub. in. of cast iron weighs 0·26 lb.

2. The cross-section of an anchor ring is an ellipse, of which the principal diameters are 3 ins. and 1·5 ins. The mean diameter of the ring is 18 ins. Find its volume.

3. Verify by the theorem of Pappus that the volume of a cone is one-third of the volume of a cylinder of the same height on the same base.

4. The mean diameter of a pneumatic tyre is 28 ins. The inside diameter of the air tube when the tyre is inflated in position is 1·3 ins. What volume of air will it hold? How many square inches of indiarubber are needed to make the inner tube?

5. Find the weight of a wrought-iron ring whose cross-section is an ellipse. Radius of ring measured to centre of ellipse = 13 ins. Principal diameters of ellipse 3 ins. and 2 ins. 1 cub. in. of wrought iron weighs 0·28 lb.

6. A bend in a wrought-iron pipe is in the form of the quadrant of a circle of mean radius 6½ ins. The bore is 2 ins., and the thickness of the metal 0·176 in. Find the weight of the bend.

CHAPTER XXVI

MOMENTS OF INERTIA

212. If a mass m moves along a straight line with uniform velocity v and without rotating, we know that its kinetic energy is equal to $\frac{1}{2}mv^2$. This quantity measures the amount of work which the body will do against a resistance before coming to rest.

We may, however, wish to know the kinetic energy of a rotating body, such as a flywheel. In this case the different parts of the body are moving with different velocities, and there is no single value of v for the whole body as in the former instance.

We require to find some method of calculating the kinetic energy of a rotating body.

First consider a simple case, such as the following :—

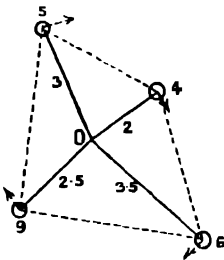

FIG. 187.

Masses of 5, 4, 6, and 9 units are fixed on a light rigid framework, whose mass may be neglected, at distances of 3, 2, 3.5, and 2.5 ft. from an axis about which the whole framework rotates at the uniform rate of ω radians per second.

Find the total kinetic energy of the four masses.

The mass of 5 units is tracing out an arc of 3ω per second, *i.e.* at any instant the linear velocity of the mass of 5 units is 3ω ft. per second. Therefore its kinetic energy is $\frac{1}{2} \cdot 5 \cdot 3^2 \cdot \omega^2$.

Similarly the kinetic energy of the mass of 4 units is $\frac{1}{2} \cdot 4 \cdot 2^2 \cdot \omega^2$, and so on.

The whole kinetic energy is

$$\frac{1}{2}(5 \times 3^2 + 4 \times 2^2 + 6 \times 3.5^2 + 9 \times 2.5^2)\omega^2 = \frac{1}{2} \cdot 190.75 \times \omega^2$$

The whole mass is 24, and

$$190.75 = 24 \times 8.25 = 24 \times (2.82)^2$$

\therefore the total kinetic energy is $\frac{1}{2} \cdot 24 \cdot (2.82)^2 \cdot \omega^2$.

This is the same as if the whole mass of 24 units were concentrated in a ring at a distance of 2.82 ft. from the axis.

The radius 2.82 ft. is called the **radius of gyration**. It is the root mean square of the distances of all the separate units of mass from the axis.

If we have any number of masses m at various distances r from the axis, and if M is the total mass and k the radius of gyration, then, as in the above example,

$$Mk^2 = \Sigma(mr^2) \bullet$$

where $\Sigma(mr^2)$ denotes the result of multiplying each mass by the square of its distance from the axis and adding the results.

The quantity $\Sigma(mr^2) = Mk^2$ is called the **moment of inertia** of the whole mass about the axis.

213. Moment of Inertia of a Continuous Rigid Body.—In actual cases, however, which occur in experience, we have to deal with the rotation of bodies whose mass is not collected at a few isolated points, as in the above example, but is spread throughout the whole of the body. In such cases we can find the moment of inertia by integration.

EXAMPLE (1).—Find the moment of inertia of a solid wheel, of uniform density and thickness, about an axis, through its centre and perpendicular to its plane.

Let a be the radius of the wheel, m the mass of a portion 1 sq. ft. in area, and of thickness equal to the thickness of the wheel, and M the mass of the whole wheel.

Divide the wheel into thin concentric rings of radius r and radial thickness δr .

Then the mass of any one ring is $m \cdot 2\pi r \delta r$.

The moment of inertia of one ring is $m \cdot 2\pi r \delta r \cdot r^2 = 2\pi r^3 \cdot m \delta r$.

The moment of inertia of the whole wheel is the limit of the sum of the terms $2\pi r^3 m \delta r$ for all the rings from $r = 0$ to $r = a$, when δr is taken smaller and smaller.

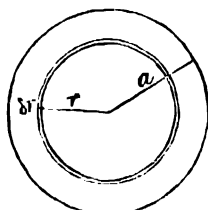

FIG. 188.

$$\therefore \text{the moment of inertia} = \int_0^a 2\pi r^3 m \delta r = \frac{\pi a^4 m}{2}$$

The mass of the whole wheel is $\pi a^2 m$

$$\therefore \text{moment of inertia} = \pi a^2 m \cdot \frac{a^2}{2} = M \frac{a^2}{2}, \text{ and } k^2 = \frac{a^2}{2}$$

i.e. the energy of the rotating wheel is the same as if its whole mass were concentrated in a ring of radius $\frac{a}{\sqrt{2}} = 0.707a$.

EXAMPLE (2).—Find the moment of inertia of a uniform rectangle, of length a and breadth b , about an axis through its centre parallel to the side b .

In speaking of the moment of inertia of an area, we shall take the mass of unit area as the unit of mass, so that the mass of any portion of the figure may be taken as numerically equal to its area.

Take the mid point of the side $DC = a$ as origin and axes along and perpendicular to DC .

Divide the rectangle into thin strips of breadth δx and length b by lines parallel to Oy . Then mass of one strip = $b\delta x$.

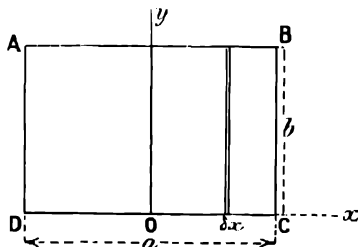

FIG. 189.

$$\therefore \text{moment of inertia of one strip about } Oy = b\delta x \cdot x^2 = bx^2\delta x.$$

Moment of inertia of whole rectangle = limit of sum of terms $bx^2\delta x$, when δx is indefinitely diminished

$$\begin{aligned}
 &= \int_{-\frac{a}{2}}^{+\frac{a}{2}} bx^2 dx \\
 &= b \left[\frac{x^3}{3} \right]_{-\frac{a}{2}}^{+\frac{a}{2}} \\
 &= \frac{ba^3}{12} = ab \frac{a^2}{12} = M \frac{a^2}{12} \\
 \therefore k^2 &= \frac{a^2}{12}
 \end{aligned}$$

EXAMPLE (3).—Find the moment of inertia and radius of gyration of a triangle ABC about an axis through A and parallel to BC.

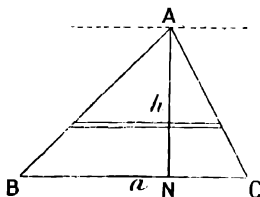

FIG. 190.

Draw AN perpendicular to BC, and take AN as axis of x ; let AN = h . Divide the triangle into thin strips parallel to BC.

Let x be the distance of any strip from A, and δx its width.

Then its length = $\frac{a}{h} \cdot x$, and its mass = $\frac{a}{h} x \delta x$.

$$\therefore \text{moment of inertia of the strip} = \frac{a}{h} \cdot x^3 \delta x$$

$$\text{Moment of inertia of whole triangle} = \int_0^h \frac{a}{h} x^3 dx = \frac{a}{h} \cdot \frac{h^4}{4} = \frac{ah^3}{4} = \frac{ah}{2} \cdot \frac{h^2}{2} = M \cdot \frac{h^2}{2}$$

$$\text{and } k^2 = \frac{h^2}{2}$$

EXAMPLES.—CXIII.

1. Weights of 5, 7, 12, and 14 lbs. are fixed to a light rigid framework at distances of 3, 4, 7, and 2 ins. respectively from a fixed axis. If the whole framework revolves about the axis at 300 revolutions per minute, what is the total kinetic energy of the weights? At what distance from the axis should they all be placed together so as to have the same total kinetic energy?

NOTE.—To get the kinetic energy in foot-pounds, take 32.2 lbs. as the unit of mass, and 1 ft. as the unit of length.

2. Find the moment of inertia about its axis of a hollow cylinder of mass M , inner radius b , outer radius a .

3. Find the moment of inertia of a thin bar, 3 ft. long, and weighing 3.5 lbs., about an axis through one end and perpendicular to its length. What is its kinetic energy when it is rotating about this axis at the rate of 100 revolutions per minute?

4. Find the moment of inertia of a uniform rectangular sheet of metal, 3 ft. by 4 ft., weighing 6 lbs., about an axis through one of the shorter sides.

214. Moment of Inertia about Two Perpendicular Axes.—If we know the moment of inertia of an area about two perpendicular axes in its plane, we can find its moment of inertia about a third axis perpendicular to its plane.

Let (x, y) be the co-ordinates of a point P in the area. Then the moment of inertia of a small mass δM at P about the axis of x is $y^2\delta M$, and its moment of inertia about the axis of y is $x^2\delta M$. But the moment of inertia about an axis through O and perpendicular to the plane of the area is $r^2\delta M = x^2\delta M + y^2\delta M$; *i.e.* the moment of inertia of each element of mass δM about an axis through O and perpendicular to OX and OY is equal to the sum of its moments of inertia about OX and OY . It follows by addition that this is also the case for the moment of inertia of the whole area, or, if I_1 and I_2 are the moments of inertia of the area about OX and OY , and I is the moment of inertia about OZ , which is perpendicular to OX and OY , then

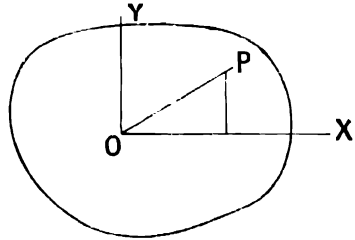

FIG. 191.

$$I = I_1 + I_2$$

EXAMPLE.—To find the moment of inertia of a circular disc about a diameter.

We have seen that the moment of inertia about an axis through the centre, and perpendicular to the plane of the circle, is $M\frac{a^2}{2}$. This is the sum of the moments of inertia about two diameters at right angles by the above theorem.

By symmetry these moments of inertia are equal, and therefore each of them is equal to $M\frac{a^2}{4}$.

215. Principle of Parallel Axes.—Given the moment of inertia of a body about an axis through its centre of gravity, to find its moment of inertia about a parallel axis at a distance h from the former.

Let P be any point in the body, and let a plane through P perpendicular to the two axes cut the axis through the centre of gravity in G and the other axis in O . Then $OG = h$.

Produce OG to N , and draw PN perpendicular to ON . Let $PG = r$, $GN = x$, and let there be a small element of mass δM at P . Then the moment of inertia of δM about the axis through O is

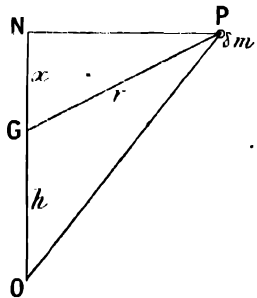

FIG. 192.

$$OP^2 \cdot \delta M = h^2 + r^2 + 2hx \dots (\S 27)$$

The moment of inertia of the whole body about the axis through O is therefore

$$\begin{aligned} I_1 &= \sum(h^2 + r^2 + 2hx)\delta M \\ &= h^2\sum\delta M + \sum(r^2\delta M) + 2h\sum(x\delta M) \end{aligned}$$

But $\sum\delta M = M$, the whole mass of the body
 $\sum(r^2\delta M) =$ moment of inertia of the body about the axis through $G = I$
 $\sum(x\delta M) = Mx = 0 \dots \dots \dots (\S 202)$

where \bar{x} is the value of x at the centre of gravity, and is zero, since the axis at G passes through the centre of gravity.

$$\therefore I_1 = I + M \cdot h^2$$

Or, in words, the moment of inertia about any axis is equal to the moment of inertia about a parallel axis through the centre of gravity, together with the moment of inertia about the former axis of the whole mass supposed concentrated at the centre of gravity.

It follows that the moment of inertia about an axis through the centre of gravity is less than about any other parallel axis.

EXAMPLE.—To find the moment of inertia of a rectangle about one edge.

Let a and b be the length and breadth of the rectangle.

We have shown that the moment of inertia about an axis through the centre of gravity, and parallel to the edge b , is $M \frac{a^2}{12}$.

We require the moment of inertia about an axis parallel to this, and at a distance $\frac{a}{2}$ from it.

$$h = \frac{a}{2}$$

$$\therefore I_1 = M \frac{a^2}{12} + M \frac{a^2}{4} = M \frac{a^2}{3}$$

EXAMPLES.—CXIV.

1. Find the radius of gyration about one side, of an equilateral triangle whose sides are 6 ins. long.

2. Find the radius of gyration of a circle of radius a about a tangent.

3. The section of a T-iron is in the form shown in the figure. $BC = 4''$, $AB = 0.5''$, $DE = 3.5''$, $EF = 0.5''$. Find the moment of inertia of the area of the section about an axis through its centre of gravity parallel to BC .

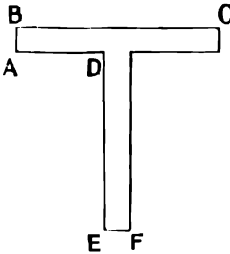

FIG. 193.

4. In the section of a T-iron, $BC = 4''$, $AB = EF = 0.5''$, $ED = 2.5''$. Find the moment of inertia of the area of the section about an axis through the centre of gravity parallel to BC .

5. A girder is formed of four equal rectangular plates 5" wide and 0.5" thick. In section they enclose a rectangle 5" by 3.5", the top and bottom plates overlapping the side plates by 0.25" on each side. Find the moment of inertia of the area of the section about an axis through the centre of gravity, and parallel to the top and bottom plates.

6. A solid wheel of 1 ft. radius and uniform thickness and density weighs 50 lbs. Find its kinetic energy in foot-pounds, 1st when it rotates about an axis through its centre and perpendicular to its plane, 2nd when it rotates about a parallel axis 0.5 in. from the former. It makes 20 revolutions per second in both cases.

7. What is the moment of inertia about a diameter of the cross-section of a hollow cylindrical tube, 1 in. in outside diameter and $\frac{1}{10}$ in. thick?

210. Moment of Inertia of an Area about an Axis in its Plane.

In general, to find the moment of inertia, of the area, bounded by the

curve $y = f(x)$ and the axis of x , about the axis of y , we divide the area into thin strips of thickness δx and parallel to Oy .

Then the mass of each strip is $y\delta x$, and x is its distance from Oy .

\therefore its moment of inertia about Oy is $x^2y\delta x$, and the moment of inertia

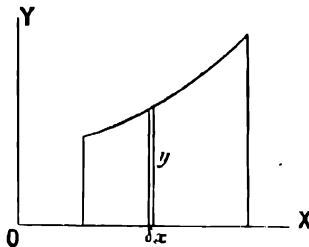

FIG. 194.

of the whole area about Oy is the limit of $\Sigma(x^2y\delta x)$ as δx is indefinitely diminished.

$$\therefore \text{moment of inertia about } Oy = \int_a^b x^2 y dx$$

where a and b are the limiting values of x for the area considered.

Similarly, moment of inertia about Ox of the area between a curve and the axis of $y = \int_c^d y^2 x dy$, where c and d are the limiting values of y .

If we know the relation between y and x , and can evaluate the above integrals, the moments of inertia can be calculated directly. If not, we can find the values of the integrals for any particular case by the graphic method.

EXAMPLE.—The shape of the quarter section of a hollow pillar is given by the following table: The axes of x and y are the shortest and longest diameters. The other three quarter sections are equal and symmetrically placed to the one shown. Find the moment of inertia of the section about the axes of x and y .

x ins. . . .	0	1	1.5	2.0	2.2	2.3	3.0	3.2	3.3
Outside y_1 ins.	6	5.76	5.44	4.99	4.75	4.64	3.0	2.0	0
Inside y_2 ins. .	5	4.47	3.86	2.80	1.90	0	—	—	—

Plotting these values we get the form of the quarter section $ABCD$.

The moment of inertia about Oy is $\int_0^{3.3} yx^2 dx$, where y is the height of a strip of

the area parallel to Oy , i.e. $y = y_1 - y_2$.

Accordingly we measure a number of values of y at suitable intervals, multiply each by the corresponding value of x^2 , and plot the curve so obtained.

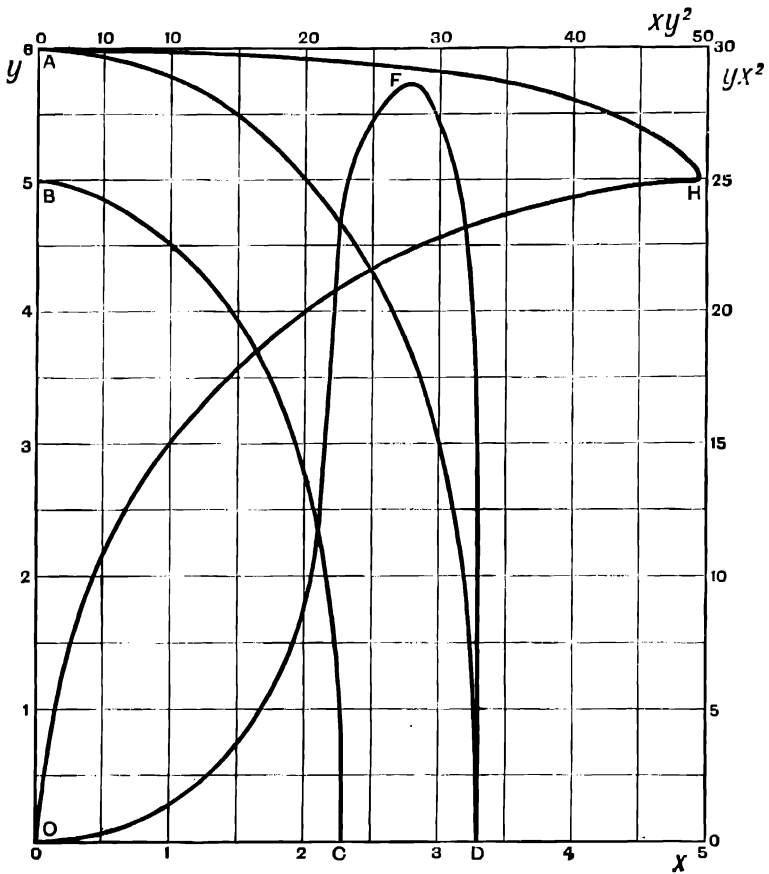

FIG. 195.

<i>x</i>	0	0.5	1	1.5	2.0	2.1	2.2	2.3	2.5	2.8	3.0	3.1	3.2	3.3
<i>y</i>	1	1.1	1.29	1.59	2.17	2.42	3.85	4.64	4.33	3.65	3.0	2.60	2.0	0
<i>yx²</i>	0	0.275	1.29	3.89	8.68	10.62	18.63	24.5	27.07	28.6	27	24.95	20.48	0

Plotting the calculated values of yx^2 as ordinates, and the values of x as abscissæ, we get the curve OFD.

Then moment of inertia of quarter section about Oy

$$= \int_0^{3.3} yx^2 dx = \text{area OFD}$$

$$= 35.45$$

and the moment of inertia of the whole section about $\overset{\bullet}{O}y$ is $4 \times 35.45 = 141.8$.

To find the moment of inertia about the axis of x , we require to find the value of $\int_0^6 xy^2 dy$, where x denotes the width of the area **ABCD** measured parallel to Ox .

Calculating the values of xy^2 and plotting, we get the curve **AHO**. Then moment of inertia of quarter section about

$$Ox = \int_0^6 xy^2 dy = \text{area AHO} = 93.7$$

and the moment of inertia of the whole section about Ox is $4 \times 93.7 = 374.8$.

EXAMPLES.—CXV.

1. The section of a solid pillar is a regular hexagon, whose sides measure 6 ins. Find the moment of inertia of this section about a diameter by the graphic method, and verify your result by integration.

2. The quarter section of a solid beam is given by the following ordinates and abscissæ. The axes of x and y are the shortest and longest diameters of the section which is symmetrical with respect to these axes. Find the moment of inertia of the whole section about Oy .

x	0	1	1.6	2	2.2	2.6	3	3.4	4
y	7	6.76	6.4	6	5.8	5.27	4.6	3.6	0

CHAPTER XXVII

PARTIAL DIFFERENTIATION

217. Function of Two or more Variables.—We have already met with many instances in which there were two variable quantities connected in such a way that if the value of one was fixed the value of the other was determined. In such a case the second variable was called a function of the first.

It is also possible for a variable to be a function of two or more other variables.

Suppose, for instance, that a point **P** can move about on a fixed surface such as that of a sphere (Fig. 196). Let its position be denoted by its rectangular co-ordinates (x, y, z) with respect to fixed rectangular axes through the centre of the sphere.

Then the co-ordinate z is a function of the two co-ordinates x and y .

For, if y alone is known, the point **P** may lie anywhere on a line such as **AB**, and the value of z is not determined.

Similarly, if x alone is known, the point may be anywhere on a line such as **CD**, and the value of z is not determined.

If both x and y are known, **P** can only lie where two definite lines such as **AB** and **CB** intersect, and the value of z is determined.

We express this by saying that z is a function of both x and y , or $z = f(x, y)$.

An equation of the form $z = f(x, y)$ can evidently be represented by a surface in the same way as equations of the form $y = f(x)$ are represented by curves in plane geometry. As another example, consider the case of a definite quantity of a gas enclosed in a vessel. We can alter its state by changing its pressure, its volume, or its temperature. It is found that if any two of these are fixed, the third is determined, *e.g.* if the pressure and temperature of a certain definite quantity of a gas are known, its volume is determined, or v is a function of p and t .

The intrinsic energy **E** of a definite quantity of a substance is determined when its pressure and volume, or its volume and temperature, or its temperature and pressure are known, *i.e.* **E** is a function of p and v , or of v and t , or of t and p .

Similarly, the potential **V** at any point **P** in a field of force is only determined when we know the three co-ordinates (x, y, z) of **P**, or

$$\mathbf{V} = f(x, y, z)$$

218. Partial Differential Co-efficients.—Let $x = f(x, y)$; then, if we suppose y to remain constant while x changes, z will in general change in a definite way.

The rate of increase of z with respect to x while y remains constant

is called the partial differential coefficient of z with respect to x , and is written $\frac{\partial z}{\partial x}$ or $\left(\frac{dz}{dx}\right)_y$.

Similarly, $\frac{\partial z}{\partial y}$ or $\left(\frac{dz}{dy}\right)_x$ denotes the rate of increase of z with respect to y while x is constant.

The suffix denoting the variable, which is supposed to remain constant, is usually omitted unless there is some special reason for inserting it to prevent misconception; the brackets are also often omitted when it is obvious that the differentiation is partial.

In the same way, if u is a function of three variables x, y , and z , $\frac{\partial u}{\partial x}$ or $\left(\frac{du}{dx}\right)_{yz}$ denotes the rate of increase of u with respect to x , while y and z are supposed to remain constant.

To find $\frac{\partial z}{\partial x}$ when z is given as a function of x and y by means of an equation, we differentiate z with respect to x alone, treating y as a constant.

EXAMPLE (1).—Let $z = x^2 - 2xy + y^2$.

$$\begin{aligned}\frac{\partial z}{\partial x} &= \left(\frac{dz}{dx}\right)_y = 2x - 2y \\ \frac{\partial z}{\partial y} &= \left(\frac{dz}{dy}\right)_x = -2x + 2y\end{aligned}$$

EXAMPLE (2).—Let $y = \sin(ct - x)$ where c is a constant.

$$\begin{aligned}\text{Then } \left(\frac{dy}{dx}\right)_t &= -\cos(ct - x) \\ \left(\frac{dy}{dt}\right)_x &= c \cos(ct - x)\end{aligned}$$

EXAMPLE (3).—Let $z = x^4 - 4x^2y + xy^3 + \sin(x - 2y) + 3 \cos(2x - y) + e^{2xy}$.

$$\begin{aligned}\left(\frac{dz}{dx}\right)_y &= 4x^3 - 8xy + y^3 + \cos(x - 2y) - 6 \sin(2x - y) + 2ye^{2xy} \\ \left(\frac{dz}{dy}\right)_x &= -4x^2 + 3xy^2 - 2 \cos(x - 2y) + 3 \sin(2x - y) + 2xe^{2xy}\end{aligned}$$

219. Geometrical Illustration.—Let the three co-ordinates (x, y, z) of a point P be connected by the equation $z = f(x, y)$.

Then, if we take a number of pairs of values of x and y , and calculate the corresponding values of z by means of the above equation, we shall find in general that the points whose three co-ordinates are thus found lie on a surface. $z = f(x, y)$ is known as the equation to this surface.

If we suppose the point P to move along the surface so as to keep the value of y constant, it will move along a section AB of the surface by a plane parallel to zx . $\frac{\partial z}{\partial x}$ is then equal to the slope of the curve AB to the plane Oxy , or the tangent of the angle which the tangent PM to the curve AB makes with a line parallel to the axis of x .

In the figure

$$\begin{aligned}\frac{\partial z}{\partial x} &= \text{tangent of angle between } QM \text{ and } PM \\ &= -\tan PMQ\end{aligned}$$

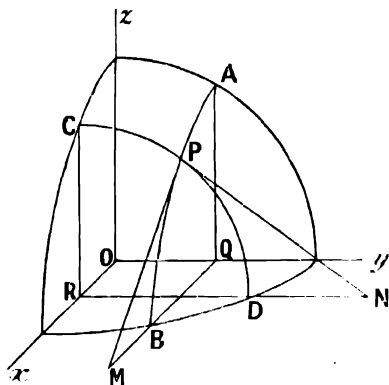

FIG. 196.

Similarly, if we suppose x to remain constant, P is restricted to a curve such as CD , and $\frac{\partial z}{\partial y}$ is equal to the slope of the curve CD to the plane Oxy .

In the figure

$$\frac{\partial z}{\partial y} = -\tan PNR$$

EXAMPLES. CXVI.

Find the values of the following :—

1. $\frac{\partial}{\partial x}(ax^ny^m)$, $\frac{\partial}{\partial y}(ax^ny^m)$, where a is a constant.
2. $\frac{\partial}{\partial x}(ae^{bx})$, $\frac{\partial}{\partial y}(ae^{bx})$, $\frac{\partial}{\partial x}(ae^{bx+cy})$, $\frac{\partial}{\partial y}(ae^{bx+cy})$, where a , b , and c are constants.
3. $\frac{\partial}{\partial x}\{a \sin(bx + cy)\}$, $\frac{\partial}{\partial y}\{a \sin(bx + cy)\}$, $\frac{\partial}{\partial x}\{a \cos(bx + cy)\}$, $\frac{\partial}{\partial y}\{a \cos(bx + cy)\}$.
4. Let $z = 3x^2 - 2xy$.

Find $\frac{\partial z}{\partial x}$ and $\frac{\partial z}{\partial y}$ by differentiation.

Then take $x = 10$, $y = 12$; increase x by the amount $\delta x = 0.1$, y remaining constant and equal to 12, and calculate the resulting increase δz in z . Thence find $\left(\frac{\delta z}{\delta x}\right)$ arithmetically, and compare with the value of $\frac{\partial z}{\partial x}$ already found.

Similarly, find $\left(\frac{\delta z}{\delta y}\right)$ by the arithmetical method, and compare.

5. If (r, θ) are the polar and (x, y) the rectangular co-ordinates of the same point on a plane prove that

$$\frac{\partial r}{\partial x} = \cos \theta, \quad \frac{\partial r}{\partial y} = \sin \theta$$

6. If $y = A \sin \frac{n\pi x}{l} \cos \left(\frac{n\pi ct}{l} + \alpha \right)$, find $\left(\frac{dy}{dx} \right)_t$ and $\left(\frac{dy}{dt} \right)_x$

A, n, l, c, α are constants.

7. If the pressure p , volume v , and absolute temperature T of a gas are connected by the equation $pv = RT$, where R is constant, find the values of

$$\left(\frac{dp}{dv} \right)_T; \quad \left(\frac{dp}{dT} \right)_v; \quad \left(\frac{dv}{dT} \right)_p; \quad \left(\frac{dT}{dv} \right)_p$$

Note the physical meaning of the sign of each of these quantities.

8. If $r = \sqrt{x^2 + y^2 + z^2}$, find $\frac{\partial r}{\partial x}, \frac{\partial r}{\partial y}, \frac{\partial r}{\partial z}$.

220. Small Variations.—Let z be a function of x and y , and let x, y , and z be represented by the co-ordinates of a point P .

Suppose P to move into a new position Q close to its former position on the surface representing the function z .

Then we may suppose P to reach Q by first moving to P_1 on the surface so that x alone increases by a small amount δx , while y remains constant, and then moving from P_1 to Q so that x remains constant while y increases by a small amount δy .

In the figure $PM = \delta x, P_1N = \delta y$.

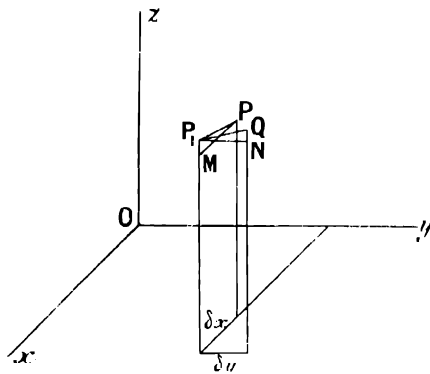

FIG. 197.

During the first movement from P to P_1 , z increases by the amount MP_1 in the figure, while x increases by the amount $PM = \delta x$. Thus

$$\begin{aligned} P_1M &= \delta x \times \tan \angle MPP_1 \\ &= \delta x \times (\text{mean value of } \frac{\partial z}{\partial x} \text{ on the surface between } P \text{ and } P_1) \end{aligned}$$

Similarly, during the second part of the movement the change in z is NQ . And

$$\begin{aligned} NQ &= \delta y \times \tan NP_1Q \\ &= \delta y \times (\text{mean value of } \frac{\partial z}{\partial y} \text{ on the surface between } P_1 \text{ and } Q) \end{aligned}$$

The whole change δz in z during the movement from P to Q is made up of the two parts MP_1 and NQ . MP_1 is the change in z , which would take place if x alone changed by the same amount as it actually does while y remained constant, and NQ is the change in z which would take place if y alone changed and x remained constant.

As δx , δy , δz are made smaller and smaller the points P , P_1 , Q move nearer together, and the mean values of $\frac{\partial z}{\partial x}$ and $\frac{\partial z}{\partial y}$ become more and more nearly equal to the exact values at P .

Thus, if δx , δy , δz are sufficiently small

$$\begin{aligned} \delta z &= MP_1 + NQ \\ &= \frac{\partial z}{\partial x} \delta x + \frac{\partial z}{\partial y} \delta y \end{aligned}$$

EXAMPLE (1).—The side a of a triangle is calculated from the following observed values:—

$$A = 27^\circ, B = 54^\circ, b = 235 \text{ ft.}$$

If the correct values are $A = 26.5^\circ$, $B = 54.9^\circ$, what is the error in the calculated value of a due to the errors in the observed values of A and B ?

We have

$$a = b \frac{\sin A}{\sin B}$$

If there are small errors δA , δB , in the values of A and B , the consequent error in a is

$$\delta a = \left(\frac{da}{dA} \right)_B \delta A + \left(\frac{da}{dB} \right)_A \delta B$$

We have

$$\begin{aligned} \delta A &= 0.5^\circ = 0.00873 \text{ radian} \\ \delta B &= -0.9^\circ = -0.01571 \text{ radian} \end{aligned}$$

$$\text{Also } \left(\frac{da}{dA} \right)_B = \frac{b \cos A}{\sin B} = \frac{235 \cos 27^\circ}{\sin 54^\circ} = 259$$

$$\left(\frac{da}{dB} \right)_A = -\frac{b \sin A \cos B}{\sin^2 B} = -\frac{235 \sin 27^\circ \cos 54^\circ}{\sin^2 54^\circ} = -95.8$$

\therefore The error in the value of $a = \delta a = 259 \times 0.00873 + 95.8 \times 0.01571 = 3.8 \text{ ft.}$

EXAMPLE (2).—A certain quantity of air at pressure 2000 lbs. per square foot and temperature 10° C. occupies 12 cubic feet. What change in volume will be produced if the pressure is increased by 2 lbs. per square foot and the temperature by 1° C. It is given that $pv = RT$, where p is the pressure, v the volume, and T the absolute temperature of the air and R is a constant.

By substituting the given values, we find $R = 84.5$.

We have

$$\begin{aligned} \delta v &= \frac{\partial v}{\partial p} \delta p + \frac{\partial v}{\partial T} \delta T \\ v &= \frac{RT}{p} \\ \therefore \frac{\partial v}{\partial p} &= -\frac{RT}{p^2} = -0.006 \end{aligned}$$

with the given values of p , v , and T .

$$\begin{aligned} \frac{\partial v}{\partial T} &= \frac{R}{p} = 0.0425 \\ \delta p &= 2, \quad \delta T = 1 \end{aligned}$$

$$\begin{aligned} \therefore \text{Substituting, the increase in volume} &= \delta v = -0.012 + 0.042 \\ &= 0.03 \text{ cub. ft.} \end{aligned}$$

EXAMPLES.—CXVII.

1. A certain quantity of air occupies 10 cub. ft. at pressure 2116 lbs. per square foot, and absolute temperature 250° C. Find the change in pressure when the volume is diminished by 0.1 cub. ft., and the temperature increased by 2° .

2. With the same data as in example 1, find the change in temperature when the volume is diminished by 0.2 cub. ft., and the pressure increased by 5 lbs. per square foot.

3. With the same data, find the change in volume when the temperature increases by 2° , and the pressure by 2 lbs. per square foot.

4. (r, θ, ϕ) are the polar, and (x, y, z) the rectangular co-ordinates of the same point P. What change is produced in x by given changes $\delta\theta$ in θ and $\delta\phi$ in ϕ ?

221. **Successive Partial Differentiation.**—Let z be a function of x and y . Then we have seen that $\frac{\partial z}{\partial x}$ denotes the result of differentiating z with respect to x , y being treated as a constant. The result of this operation is, in general, itself a function of x and y .

If it is differentiated again with respect to x , y being still treated as a constant, the result is $\frac{\partial}{\partial x} \left(\frac{\partial z}{\partial x} \right)$, which is written $\frac{\partial^2 z}{\partial x^2}$ or $\left(\frac{d^2 z}{dx^2} \right)$.

If $\frac{\partial z}{\partial x}$ is differentiated with respect to y , x being treated as a constant, the result is $\frac{\partial}{\partial y} \left(\frac{\partial z}{\partial x} \right)$, which is written $\frac{\partial^2 z}{\partial y \partial x}$ or $\left(\frac{d^2 z}{dy dx} \right)$.

Similarly, $\frac{\partial^2 z}{\partial x \partial y}$ denotes the result of first differentiating z with respect to y , treating x as a constant, and then differentiating the result with respect to x , treating y as a constant.

$\frac{\partial^2 z}{\partial y^2}$ denotes the result of differentiating z twice in succession with respect to y , treating x as a constant.

In the same way, we may proceed to partial differential coefficients of a higher order.

EXAMPLE (1).—

$$\begin{aligned}
 z &= x^4 - 3x^2y + 3xy^2 + y^4 \\
 \frac{\partial z}{\partial x} &= 4x^3 - 6xy + 3y^2. \\
 \frac{\partial^2 z}{\partial x^2} &= 12x^2 - 6y. \\
 \frac{\partial^2 z}{\partial y \partial x} &= -6x + 6y. \\
 \frac{\partial z}{\partial y} &= -3x^2 + 6xy + 4y^3. \\
 \frac{\partial^2 z}{\partial y^2} &= 6x + 12y^2. \\
 \frac{\partial^2 z}{\partial x \partial y} &= -6x + 6y.
 \end{aligned}$$

Note that

$$\frac{\partial^2 z}{\partial x \partial y} = \frac{\partial^2 z}{\partial y \partial x}$$

or, the order in which we differentiate with respect to x and y does not affect the result. We shall find that this is the case for all the functions with which we deal in this book.

EXAMPLE (2).—If V is the potential at any point (x, y, z) in a field of force, then it can be shown from the definition of potential that the component X parallel to the axis of x of the force at any point in the field is equal to the rate of decrease of the potential per unit increase of x at that point.

$$\begin{aligned}
 \text{Or } X &= -\left(\frac{dV}{dx}\right) \\
 \text{Similarly } Y &= -\left(\frac{dV}{dy}\right), \quad Z = -\left(\frac{dV}{dz}\right)
 \end{aligned}$$

where Y and Z are the components of the force parallel to Oy and Oz .

Show that if the potential at any point varies inversely as its distance from O , then the resultant force at any point varies inversely as the square of its distance from O .

Let F be the resultant force at a point $P(x, y, z)$, and X, Y, Z its components parallel to Ox, Oy, Oz respectively.

$$\text{Then } F^2 = X^2 + Y^2 + Z^2.$$

Also we have

$$X = -\left(\frac{dV}{dx}\right), \quad Y = -\left(\frac{dV}{dy}\right), \quad Z = -\left(\frac{dV}{dz}\right)$$

We have

$$V = \frac{C}{r} = \frac{C}{\sqrt{x^2 + y^2 + z^2}}$$

where c is constant.

$$\begin{aligned}
 \text{Then } X &= -\left(\frac{dV}{dx}\right) = \frac{Cx}{(x^2 + y^2 + z^2)^{\frac{3}{2}}} \\
 Y &= -\left(\frac{dV}{dy}\right) = \frac{Cy}{(x^2 + y^2 + z^2)^{\frac{3}{2}}} \\
 Z &= -\left(\frac{dV}{dz}\right) = \frac{Cz}{(x^2 + y^2 + z^2)^{\frac{3}{2}}}
 \end{aligned}$$

∴ squaring and adding,

$$F^2 = \frac{C^2(x^2 + y^2 + z^2)}{(x^2 + y^2 + z^2)^2} = \frac{C^2}{(x^2 + y^2 + z^2)^2} = \frac{C^2}{r^4}$$

$$\therefore F = \frac{C}{r^2}$$

or the force varies inversely as the square of the distance from **O**.

EXAMPLES.—CXVIII.

1. If $z = x^3 - 3x^2y^2 - 3x^2y + y^4$, find the values of

$$\frac{\partial z}{\partial x}, \frac{\partial z}{\partial y}, \frac{\partial^2 z}{\partial x^2}, \frac{\partial^2 z}{\partial y^2}, \frac{\partial^2 z}{\partial x \partial y}, \frac{\partial^2 z}{\partial y \partial x},$$

and verify that the last two are equal.

2. If $z = 3 \sin(2x + 3y) - 2e^{xy}$, find

$$\frac{\partial z}{\partial x}, \frac{\partial z}{\partial y}, \frac{\partial^2 z}{\partial x^2}, \frac{\partial^2 z}{\partial y^2}, \frac{\partial^2 z}{\partial x \partial y}, \frac{\partial^2 z}{\partial y \partial x}$$

3. Verify that $\frac{\partial^2 z}{\partial y \partial x} = \frac{\partial^2 z}{\partial x \partial y}$ in the following cases :—

$$z = ax^ny^m, \quad z = ae^{bxy}, \quad z = a^{bx+cy}$$

$$z = a \sin(bx + cy), \quad z = a \cos(bx + cy)$$

$$z = ae^{bxy} \sin(cx + dy)$$

4. If the potential V at a point **P** (x, y, z) varies inversely as the distance of **P** from the origin **O**, show that V satisfies the equation

$$\frac{\partial^2 V}{\partial x^2} + \frac{\partial^2 V}{\partial y^2} + \frac{\partial^2 V}{\partial z^2} = 0$$

5. y is the displacement at time t of a point on a vibrating stretched string at distance x from one end. It is known that $\left(\frac{d^2 y}{dt^2}\right)_x = c^2 \left(\frac{d^2 y}{dx^2}\right)$. Show that this equation is satisfied if

$$y = A \sin \frac{\phi x}{c} \sin(\rho t + \alpha)$$

where A, ϕ, c, α are constants.

CHAPTER XXVIII

MISCELLANEOUS METHODS OF INTEGRATION

222. WE shall here give examples of some methods of integration somewhat more difficult than those treated in Chapter XVI.

EXAMPLE (1).— $\int \sin^2 x dx$.

We have

$$\begin{aligned}\int \sin^2 x dx &= \int \frac{1}{2}(1 - \cos 2x) dx \\ &= \frac{x}{2} - \frac{1}{4} \sin 2x\end{aligned}$$

EXAMPLE (2).— $\int \tan^2 x dx = \int (\sec^2 x - 1) dx = \tan x - x$.

EXAMPLE (3).— $\int a^x dx$.

We have

$$\begin{aligned}a &= e^{\log_e a} \\ \therefore \int a^x dx &= \int e^{(\log_e a)x} dx = \frac{1}{\log_e a} e^{x \log_e a} \\ &= \frac{a^x}{\log_e a}\end{aligned}$$

EXAMPLE (4).— $\int \frac{dx}{x^2 - a^2}$.

We have

$$\begin{aligned}\frac{1}{x^2 - a^2} &= \frac{1}{2a} \left\{ \frac{1}{x - a} - \frac{1}{x + a} \right\} \\ \therefore \int \frac{dx}{x^2 - a^2} &= \frac{1}{2a} \left\{ \int \frac{dx}{x - a} - \int \frac{dx}{x + a} \right\} \\ &= \frac{1}{2a} \{ \log_e (x - a) - \log_e (x + a) \} \\ &= \frac{1}{2a} \log_e \frac{x - a}{x + a}\end{aligned}$$

Similarly

$$\int \frac{dx}{(x + a)^2 - b^2} = \frac{1}{2b} \log_e \frac{x + a - b}{x + a + b}$$

EXAMPLE (5).— $\int \frac{dx}{x^2 + 3x - 5}$.

We have $x^2 + 3x - 5 = x^2 + 3x + \frac{9}{4} - 5 - \frac{9}{4}$
 $= (x + \frac{3}{2})^2 - \frac{29}{4}$
 $= (x + \frac{3}{2})^2 - \left(\frac{\sqrt{29}}{2}\right)^2$

$\therefore \int \frac{dx}{x^2 + 3x - 5} = \frac{1}{\sqrt{29}} \log_e \frac{x + \frac{3}{2} - \frac{\sqrt{29}}{2}}{x + \frac{3}{2} + \frac{\sqrt{29}}{2}}$ by example (4)
 $= \frac{1}{\sqrt{29}} \log_e \frac{2x + 3 - \sqrt{29}}{2x + 3 + \sqrt{29}}$

EXAMPLE (6).— $\int \frac{dx}{x^2 + a^2}$.

Let $x = a \tan y$.

Differentiating with respect to y , we have

$$\frac{dx}{dy} = a \sec^2 y = a(1 + \tan^2 y) = a \left(1 + \frac{x^2}{a^2}\right)$$

Now $\frac{dy}{dx} = \frac{1}{\frac{dx}{dy}}$

$\therefore \frac{dy}{dx} = \frac{a}{x^2 + a^2}$

and $\int \frac{dx}{x^2 + a^2} = \frac{1}{a} \int \frac{dy}{dx} dx = \frac{y}{a}$ by the definition of an indefinite integral
 $= \frac{1}{a} \tan^{-1} \frac{x}{a}$

Similarly

$$\int \frac{dx}{(x + a)^2 + b^2} = \frac{1}{b} \tan^{-1} \frac{x + a}{b}$$

EXAMPLE (7).— $\int \frac{dx}{x^2 + 3x + 5}$.

We have

$$x^2 + 3x + 5 = (x^2 + 3x + \frac{9}{4}) + 5 - \frac{9}{4}$$

$$= (x + \frac{3}{2})^2 + \left(\frac{\sqrt{11}}{2}\right)^2 \text{ by example (6)}$$

$\therefore \int \frac{dx}{x^2 + 3x + 5} = \frac{2}{\sqrt{11}} \tan^{-1} \frac{x + \frac{3}{2}}{\frac{\sqrt{11}}{2}}$
 $= \frac{2}{\sqrt{11}} \tan^{-1} \frac{2x + 3}{\sqrt{11}}$

EXAMPLES.—CXIX.

Evaluate the following integrals:—

1. $\int \cos^2 x dx$.

2. $\int_1^2 10^x dx$.

3. $\int \frac{dx}{x^2 - 4x + 7}$.

4. $\int \frac{dx}{2x^2 + 6x - 10}$.

5. $\int \frac{dx}{x^2 - 2x + 5}$.

6. $\int \frac{dx}{x^2 - 2x - 8}$.

223. Integration by Substitution.—Consider a function such as $y = (\log_e x)^2$.

Let $\log_e x = u$, then we may also write $y = u^2$.

Thus we may regard y as a function either of x or of u .

Let u increase by the amount δu while x increases by δx .

$$\text{Then } \delta u = \frac{\delta u}{\delta x} \cdot \delta x$$

$$\begin{aligned} \text{and } \int_c^a y du &= \text{limit of sum of terms } y \delta u \\ &= \text{ " " } y \frac{\delta u}{\delta x} \delta x \\ &= \int_a^b y \frac{du}{dx} dx \end{aligned}$$

where u changes from c to d , while x changes from a to b .

If we regard the upper limit as variable it follows that the indefinite integral

$$\int y du = \int y \frac{du}{dx} dx \quad \dots \dots \dots (\S 135)$$

In the case considered above, this result gives

$$\begin{aligned} \int \frac{(\log_e x)^2}{x} dx &= \int (\log_e x)^2 \cdot \frac{du}{dx} \cdot dx = \int u^2 du \\ &= \frac{u^3}{3} = \frac{1}{3} (\log_e x)^3 \end{aligned}$$

We have here shown that in an indefinite integral du may be substituted for $\frac{du}{dx} dx$ when it occurs *in the integral*, just as if du and dx were separate quantities and $\frac{du}{dx}$ were a fraction. It must be remembered, however, that no meaning has been given to du and dx standing alone, and when we use them as if they were separate terms it is understood that they occur in the expression of an integral.

EXAMPLE (1).—Integrate $\int \sin x \cos^3 x dx$.

Let $u = \cos x$.

Then du may be written for $\frac{du}{dx} dx$, i.e. for $-\sin x dx$.

$$\therefore \int \sin x \cos^3 x dx = -\int u^3 du = -\frac{u^4}{4} = -\frac{\cos^4 x}{4}$$

EXAMPLE (2).—To find $\int \frac{2x+3}{x^2+3x+4} dx$.

Let $u = x^2 + 3x + 4$.

Then $du = \frac{du}{dx} dx = (2x + 3) dx$.

$$\therefore \int \frac{2x+3}{x^2+3x+4} dx = \int \frac{du}{u} = \log_e u = \log_e (x^2 + 3x + 4).$$

EXAMPLE (3).—By an extension of the method of Example (2) we may integrate any expression of the form $\frac{ax + b}{x^2 + cx + d}$

E.g. to find $\int \frac{4x + 5}{x^2 + 3x + 7} dx$.

Let $u = x^2 + 3x + 7$.

Arrange the numerator in the form $\frac{du}{dx} \pm c$, where c is a constant, dividing out by whatever coefficient is necessary.

In this case we write the integral.

$$\int \frac{2(2x + 3) - 1}{x^2 + 3x + 7} dx$$

$$= 2 \int \frac{2x + 3}{x^2 + 3x + 7} dx - \int \frac{dx}{x^2 + 3x + 7}$$

The first of these integrals falls into the class treated in Example (2) above, and the second is of the type treated in Example (7), p. 371, and we find that the required integral

$$= 2 \log_e (x^2 + 3x + 7) - \frac{2}{\sqrt{19}} \tan^{-1} \frac{2x + 3}{\sqrt{19}}$$

EXAMPLE (4).—Find the position of the centre of gravity of the area of a semicircle of radius a .

Take axes of co-ordinates as shown in the figure, and divide the area into thin strips parallel to the axis of y . Then the mass of an element = $2y\delta x$.

We have $x^2 + y^2 = a^2$.

$$\bar{x} = \frac{\int_0^a xy dx}{\int_0^a y dx} = \frac{\int_0^a x \sqrt{a^2 - x^2} dx}{\frac{\pi}{4} a^2}$$

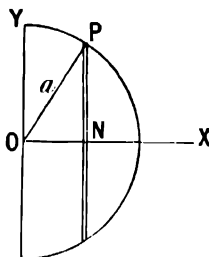

FIG. 198.

To find this integral let $x = a \sin u$.

Then $dx = \frac{dx}{du} du = a \cos u du$, and $\sqrt{a^2 - x^2} = a \cos u$.

$$\therefore \bar{x} = \frac{4}{\pi a^2} \int_0^{\frac{\pi}{2}} a \sin u \cdot a \cos u \cdot a \cos u du$$

$$= \frac{4}{\pi a^2} \int_0^{\frac{\pi}{2}} a^3 \cos^2 u \sin u du$$

the limits being chosen as shown, because $u = 0$ when $x = 0$, and $u = \frac{\pi}{2}$ when $x = a$.

Let $\cos u = v$.

Then $dv = \frac{dv}{du} du = -\sin u du$.

$$\therefore \bar{x} = -\frac{4a}{\pi} \int_1^0 v^2 dv = \frac{4a}{\pi} \cdot \frac{1}{3} = 0.424a$$

EXAMPLE (5).—Find $\int \frac{dx}{\sqrt{a^2 - x^2}}$.

Let $x = a \sin \theta$.

$$\text{Then } dx = \frac{dx}{d\theta} d\theta = a \cos \theta d\theta$$

$$\sqrt{a^2 - x^2} = a \cos \theta$$

$$\therefore \int \frac{dx}{\sqrt{a^2 - x^2}} = \int \frac{a \cos \theta d\theta}{a \cos \theta} = \int d\theta = \theta = \sin^{-1} \frac{x}{a}$$

EXAMPLE (6).—Find $\int \frac{dx}{\sin x}$.

We have $\sin x = 2 \sin \frac{1}{2}x \cos \frac{1}{2}x$.

$$\begin{aligned} \therefore \int \frac{dx}{\sin x} &= \frac{1}{2} \int \frac{dx}{\sin \frac{1}{2}x \cos \frac{1}{2}x} \\ &= \int \frac{\frac{1}{2} \sec^2 \frac{1}{2}x dx}{\tan \frac{1}{2}x} \end{aligned}$$

dividing numerator and denominator by $\cos^2 \frac{1}{2}x$

Let $\tan \frac{1}{2}x = u$.

$$\text{Then } du = \frac{du}{dx} dx = \frac{1}{2} \sec^2 \frac{1}{2}x dx.$$

$$\therefore \int \frac{dx}{\sin x} = \int \frac{du}{u} = \log u = \log \tan \frac{1}{2}x$$

No general rule can be given to find the proper substitutions and changes of variable to use in applying the method of this paragraph; it is largely a matter of practice.

A few examples for practice are given below, but the student who wishes to pursue the subject further should consult works on the integral calculus.

EXAMPLES.—CXX.

Find the following integrals:—

1. $\int \tan x dx$ (take $u = \cos x$).
2. $\int \cot x dx$.
3. $\int \frac{dx}{\cos x}$
4. $\int \frac{(2x+1)dx}{x^2+x+5}$.
5. $\int \frac{(6x+5)dx}{x^2+x+5}$.
6. $\int \frac{(5x-4)dx}{x^2+x+5}$.
7. $\int \frac{\sin x}{\cos^4 x} dx$.
8. $\int \cos x \sin^6 x dx$.
9. $\int \frac{\tan^3 x}{\cos^2 x} dx$.
10. $\int_0^a \sqrt{a^2 - x^2} dx$ (take $x = a \sin u$, as in Example (4) above).

11. Verify by integration that the area of a circle of radius a is equal to πa^2 .

NOTE.—This is not really a proof since the result is implicitly assumed in the value of π , which is taken as a limit of integration.

224. Integration by Partial Fractions.—In Chapter VI. we showed how to resolve into partial fractions a fraction of the form $\frac{ax^2 + bx + c}{dx^3 + ex^2 + fx + g}$ where the denominator is of higher degree than the numerator.

The partial fractions can be integrated separately by one or other of the methods already given.

EXAMPLE (1).—To find $\int \frac{2x-5}{2x^2+3x-2} dx$.

Resolving into partial fractions we get

$$\frac{2x-5}{2x^2+3x-2} = \frac{9}{5(x+2)} - \frac{8}{5(2x-1)} \quad (\text{Example (1), p. 76.})$$

$$\therefore \int \frac{2x-5}{2x^2+3x-2} dx = \frac{9}{5} \int \frac{dx}{x+2} - \frac{8}{5} \int \frac{dx}{2x-1}$$

$$= \frac{9}{5} \log(x+2) - \frac{4}{5} \log(2x-1)$$

EXAMPLE (2).—

$$\int \frac{dx}{(x-1)(x+2)(x-5)} = -\frac{1}{2} \int \frac{dx}{x-1} + \frac{1}{21} \int \frac{dx}{x+2} + \frac{1}{21} \int \frac{dx}{x-5} \quad (\text{Ex. (2), p. 76})$$

$$= -\frac{1}{2} \log(x-1) + \frac{1}{21} \log(x+2) + \frac{1}{21} \log(x-5)$$

EXAMPLE (3).—

$$\int \frac{dx}{(x-1)^2(x+2)(x-5)} = \frac{1}{10} \int \frac{dx}{x-1} - \frac{1}{2} \int \frac{dx}{(x-1)^2} - \frac{1}{6} \int \frac{dx}{x+2} + \frac{1}{12} \int \frac{dx}{x-5}$$

(Example (3), p. 76.)

$$= \frac{1}{10} \log(x-1) + \frac{1}{12(x-1)} - \frac{1}{6} \log(x+2) + \frac{1}{12} \log(x-5)$$

EXAMPLE (4).—

$$\int \frac{(3x+5)dx}{(x^2+x+1)(x-6)} = \frac{2}{3} \int \frac{dx}{x-6} - \frac{1}{43} \int \frac{32+23x}{x^2+x+1} \quad (\text{Example (4), p. 77.})$$

$$= \frac{2}{3} \log(x-6) - \frac{2}{43} \int \frac{2x+1}{x^2+x+1} - \frac{41}{43} \int \frac{dx}{x^2+x+1}$$

$$= \frac{2}{3} \log(x-6) - \frac{2}{43} \log(x^2+x+1) - \frac{41}{43\sqrt{3}} \tan^{-1} \frac{2x+1}{\sqrt{3}}$$

EXAMPLES.—CXXI.

Find the following integrals :—

1. $\int \frac{4x}{x^2-4} dx$. Verify by the graphic method.
2. $\int \frac{2dx}{x^2+8x+15}$.
3. $\int \frac{3x+8}{x^2+7x+6} dx$.
4. $\int \frac{5x+7}{(x-1)(x+2)(x+3)} dx$.
5. $\int \frac{4x+23}{(2x+1)(x-3)(x+2)} dx$.
6. $\int \frac{3x^2+4x-2}{(x+1)^2(x-2)} dx$.
7. $\int \frac{7x^3-24x^2+8x-5}{(x-1)^2(x-4)(x+3)} dx$.
8. $\int \frac{7x^2+13x+9}{(2x-1)(x^2+3x+4)} dx$.
9. $\int \frac{8x+11}{(x^2+x+3)(x-2)} dx$.

225. Integration by Parts.—It has been shown that, if u and v are two functions of x ,

$$\frac{d}{dx}(uv) = u \frac{dv}{dx} + v \frac{du}{dx}$$

Solving we get

$$\int e^{bx} \sin (cx + d) dx = \frac{b \sin (cx + d) - c \cos (cx + d)}{b^2 + c^2} e^{bx}$$

$$\int e^{bx} \cos (cx + d) dx = \frac{c \sin (cx + d) + b \cos (cx + d)}{b^2 + c^2} e^{bx}$$

226. It is sometimes possible to reduce an integral to a form which we can integrate by applying the process of integration by parts several times in succession.

EXAMPLE.—To find $\int x^4 e^x dx$.

Let $u = x^4$, $v = e^x$. Then $dv = e^x dx$, $du = 4x^3 dx$.

$$\therefore \int x^4 e^x dx = x^4 e^x - 4 \int x^3 e^x dx$$

The integral $\int x^3 e^x dx$ may now be reduced in the same way.

$$\begin{aligned} 4 \int x^3 e^x dx &= 4x^3 e^x - 12 \int x^2 e^x dx \\ &= 4x^3 e^x - 12x^2 e^x + 24 \int x e^x dx \\ &= 4x^3 e^x - 12x^2 e^x + 24x e^x - 24 \int e^x dx \end{aligned}$$

$$\therefore \int x^4 e^x dx = x^4 e^x - 4x^3 e^x + 12x^2 e^x - 24x e^x + 24 e^x$$

EXAMPLES.—CXXII.

Find the values of the following integrals :—

1. $\int x \cos x dx$.

2. $\int x e^{-x} dx$.

3. $\int x \log x dx$.

4. Find the mean value of $\log_{10} x$ from $x = 1$ to $x = 10$.

5. $\int x^4 \log_e x dx$.

6. $\int x^2 e^x dx$.

7. Find the mean value of $e^{-\frac{1}{2}t} \sin qt$ from $t = 0$ to $t = \frac{2\pi}{q}$.

8. Find the abscissa of the centre of gravity of the area lying between the curve $y = \sin x$ and the axis of x from $x = 0$ to $x = \frac{\pi}{2}$.

CHAPTER XXIX

SOME DIFFERENTIAL EQUATIONS OF APPLIED PHYSICS

227. IN Chapter XVII. we met with problems in which $\frac{dy}{dx}$ or $\frac{d^2y}{dx^2}$ was given as a function of x , either by means of a curve to be drawn from a number of tabulated results or by an algebraical equation.

We showed how to find the corresponding relation between y and x , and to represent it by a curve. These were examples of the solution of differential equations.

Equations involving a dependent and one or more independent variables and their differential coefficients are called Differential Equations.

The solution or integration of a differential equation consists in finding the relation between y and x which it implies.

We shall treat certain forms of differential equations which occur in applied physics.

228. I. Compound Interest Law.—There is a large class of cases in nature in which the rate of increase of a variable is proportional to the variable itself. Examples of some of these have been given in Chapter VII., § 66.

This law may be expressed by an equation in the form $\frac{dy}{dx} = by$, where b is a constant.

Now we have seen that when $y = ae^{bx}$, $\frac{dy}{dx} = abe^{bx} = by$, and therefore $y = ae^{bx}$ is a relation between y and x , which always satisfies the equation $\frac{dy}{dx} = by$.

Otherwise, we have

$$\frac{1}{y} \cdot \frac{dy}{dx} = b$$

In integrating we may separate the variables (§ 223).

$$\begin{aligned} \therefore \int \frac{dy}{y} &= \int b dx \\ \therefore \log_e y &= bx + C \end{aligned}$$

where C is the arbitrary constant of integration.

$$\therefore y = ae^{bx} \text{ where } C = \log_e a$$

The variables y and x are said to follow the Compound Interest Law for a reason which will be evident from the following considerations :—

When a sum of money is invested at compound interest payable annually, the interest for each year is added to the principal at the end of that year and proceeds to bear interest for the following year, and so on.

Thus the rate at which the interest accrues is proportional to the total amount at the end of the preceding year.

By making the interest payable more frequently we could approximate more closely to the cases of the Compound Interest Law which occur in nature.

Suppose the time to increase by a succession of small increments δt , and that the interest is added to the principal P at the end of each of these intervals. Then, if r is the rate per cent. per annum, the interest gained in time δt is $\frac{r}{100} P \delta t$, where δt is expressed as a fraction of a year and P is the total amount at the beginning of the interval δt . This is now added to the principal, and may be denoted by δP .

$$\begin{aligned} \therefore \delta P &= \frac{r}{100} P \delta t \\ \text{or } \frac{\delta P}{\delta t} &= \frac{r}{100} \cdot P \end{aligned}$$

If now the time δt is continually diminished so that in the limit we may consider the interest as continuously added to the principal, $\frac{\delta P}{\delta t}$ continually approaches a limiting value, which is the value of $\frac{dP}{dt}$ for the case where the interest is added on continuously.

$$\therefore \frac{dP}{dt} = \frac{r}{100} P$$

Comparing this with the equation given above to express the Compound Interest Law, we see that we may write P for y , t for x , $\frac{r}{100}$ for b , and the relation between P and t is therefore

$$P = a e^{\frac{r}{100} t}$$

where a is a constant.

To find a put $t = 0$, then $P = a$; *i.e.* a is the principal originally invested when $t = 0$. Writing P_0 for this, we get

$$P = P_0 e^{\frac{r}{100} t}$$

229. The exponential e^x is defined algebraically as the limiting value of $\left(1 + \frac{x}{n}\right)^n$ when n is infinite.

The student sometimes finds difficulty in understanding the connection between this definition of e^x and its use to express the Compound Interest Law, which is more important in physical applications.

It is easy to show that, if compound interest is payable m times per annum, the amount in t years at r per cent. per annum is

$$P = P_0 \left(1 + \frac{r}{100m}\right)^{mt}$$

Now write $n = \frac{100m}{r}$; then $m = \frac{nr}{100}$

and
$$P = P_0 \left(1 + \frac{r}{n} \right)^n \cdot \frac{rt}{100}$$

If we continually increase the value of m until the interest is payable continuously, m , and therefore n also, approaches the value infinity.

We have shown above that in this case $P = P_0 e^{\frac{rt}{100}}$, and therefore $e^{\frac{rt}{100}}$ is the limiting value of $\left(1 + \frac{r}{n} \right)^n$ when n is infinite.

If we write $\frac{rt}{100} = x$ we get the algebraical definition that e^x is the limiting value of $\left(1 + \frac{x}{n} \right)^n$ when n is infinite.

Thus the algebraical definition of e^x implies also its capability of expressing the Compound Interest Law.

230. The following are examples of natural phenomena which obey the Compound Interest Law :—

(1) The case of a belt or rope passing round a pulley. It can be shown that at any point on the belt in contact with the pulley the rate of increase of the tension in passing through that point along the belt from the slack to the taut side is proportional to the tension at that point. Thus the tension follows the Compound Interest Law. The results of an experimental proof of this are given on p. 154.

(2) The Compound Interest Law is also extended to include the case where the rate of decrease of a variable is proportional to that variable itself.

Newton's Law of Cooling is an instance in point. The rate of cooling of a body is under certain conditions proportional to the excess of its temperature above the temperature of its surroundings; *i.e.* the rate of decrease of the temperature θ per unit time t is proportional to the temperature, or

$$\frac{d\theta}{dt} = -a\theta$$

and therefore $\theta = \theta_0 e^{-at}$, where θ_0 is the temperature when $t = 0$ and a is a constant. For experimental results, see p. 108.

(3) If the two sides of a charged electric condenser are connected through a large resistance, the discharge takes place rapidly at first and then more slowly, the rate of decrease of the voltage at any instant being proportional to the voltage to which the condenser remains charged at that instant. Thus the Compound Interest Law connects the voltage and the time.

$$V = V_0 e^{-\frac{1}{KR}t}$$

where V is the voltage at time t , V_0 the voltage at time $t = 0$, K the capacity of the condenser, and R the resistance in the circuit.

The student may be familiar with the method of testing the insulation resistance of a cable, which depends on this law.

(4) As we pass upwards from the earth's surface into the atmosphere, the

density and pressure of the atmosphere at any height diminish; the rate of decrease of the pressure per unit rise in height is proportional to the density, and, therefore, if the temperature is constant, to the pressure at that height. Thus the pressure, regarded as a function of the height, follows the Compound Interest Law.

EXAMPLES.—CXXIII.

1. Find an expression for y in terms of x , if it is given that $\frac{dy}{dx} = 3y$, and $y = 5$ when $x = 1$.

2. What is the equation to a curve whose slope is everywhere numerically equal to one-half of its ordinate, and whose ordinate is 1 when $x = 0$?

3. A point starts at **A** and moves along a straight line **AB**, so that its velocity in feet per second is always numerically equal to its distance in feet from **B**. If **AB** is 100 ft., how long will the point take to get halfway from **A** to **B**?

4. Find the amount of £100 in 3 years at 4 per cent. per annum compound interest

- | | | |
|-----|------------------------------|--------|
| (1) | when the interest is payable | yearly |
| (2) | “ | “ |
| (3) | “ | “ |
| (4) | “ | “ |
- yearly
 half-yearly
 quarterly
 continuously

5. If θ is the temperature of a certain body at time t , it is known that the rate of cooling is equal to 0.006θ , and that when $t = 0$ the temperature is 20° C. Find an expression for θ in terms of t .

6. A rope passes round a drum. T is the tension of the rope at a distance s , measured along the rope from one end of the portion of the rope which is in contact with the drum. It can be shown that $\frac{dT}{ds} = \frac{\mu T}{r}$, where r is the radius of the drum, and μ the coefficient of friction. Find an expression for T in terms of s for the case when $\mu = 0.5$, $r = 9''$, and $T = 25$ lbs. where $s = 0$.

7. q is the quantity of the charge at time t in a condenser of capacity K , discharging through a resistance R . It can be proved that $\frac{dq}{dt} + \frac{q}{KR} = 0$. Find an expression for q in terms of t . Taking the initial charge when $t = 0$ as 0.0005 , plot a curve to show the value of q for any value of t from 0 to 0.03 secs., given $R = 5000 \times 10^9$, $K = 3 \times 10^{-12}$. In what time is the charge reduced to $\frac{1}{2}$ of its original value?

8. If i is the current at time t in a circuit of resistance R , and coefficient of self-induction L , and the impressed electro-motive force has been removed, then $L \frac{di}{dt} + Ri = 0$. Find i in terms of t , taking R and L as constants.

If $R = 0.5$ ohm, $L = 0.05$ henry, and $i = 15$ amps when $t = 0$, plot a curve to show the value of the current at any time from $t = 0$ to $t = 0.2$ secs.

231. The following is an extension of the Compound Interest Law :—

$$\text{Let } \frac{dy}{dx} + ay = b$$

where a and b are constants.

To find the law connecting y and x , we have

$$\frac{dy}{dx} = b - ay$$

∴ separating the variables and integrating

$$\int \frac{dy}{b - ay} = \int dx$$

$$\therefore -\frac{1}{a} \log_e (b - ay) = x + C$$

where C is any constant.

$$\begin{aligned} \therefore \log_e (b - ay) &= -ax - aC \\ b - ay &= e^{-ax - aC} \\ y &= Ae^{-ax} + \frac{b}{a} \end{aligned}$$

where the constant A is equal to $-\frac{e^{-aC}}{a}$

EXAMPLE.—If $\frac{dy}{dx} + 3y = 5$; find an expression for y in terms of x .

Following the above process we get

$$y = Ae^{-3x} + \frac{5}{3}$$

To verify, we find

$$\begin{aligned} \frac{dy}{dx} &= -3Ae^{-3x} \\ \therefore \frac{dy}{dx} + 3y &= -3Ae^{-3x} + 3Ae^{-3x} + 5 = 5 \end{aligned}$$

and thus the given differential equation is satisfied by this solution.

EXAMPLES.—CXXIV.

1. Take $A = 1$ in the above example, and plot the curve $y = e^{-3x} + \frac{5}{3}$ from $x = 0$ to $x = \frac{1}{3}$. Measure as accurately as possible the values of $\frac{dy}{dx}$ and y for this curve at the point where $x = 0.1$, and verify by substitution that they satisfy the equation

$$\frac{dy}{dx} + 3y = 5$$

Find the value of y in terms of x so as to satisfy the following differential equations:—

2. $\frac{dy}{dx} = y + 3.$

3. $\frac{dy}{dx} - 3y = 9.$

4. $\frac{dy}{dx} + 4y + 3 = 0.$

5. $\frac{dy}{dx} - 6y + 7 = 0.$

6. If a constant electro-motive force E be impressed on a circuit of resistance R and co-efficient of self-induction L , the current i at time t satisfies the equation

$$L \frac{di}{dt} + Ri = E$$

Find an expression for i in terms of t , choosing the constant of integration so that $i = 0$ when $t = 0$.

If $R = 0.5$ ohm, $L = 0.05$ henry, and $E = 7$ volts, plot a curve to show the value of the current at any time from $t = 0$ to $t = 0.3$ secs.

From the shape of the curve deduce the probable value of the current at the end of 5 seconds. Measure the slope of your curve at $t = 0.1$, and verify that i and $\frac{di}{dt}$ at this instant satisfy the given differential equation.

7. In an electric circuit of resistance R , and coefficient of self-induction L , there is a simple harmonic impressed electro-motive force $E \sin qt$.

Then it is known that the current i at time t satisfies the equation

$$L \frac{di}{dt} + Ri = E \sin qt$$

where L , R , and E are constants.

Show that this equation is satisfied if

$$i = \frac{E}{\sqrt{R^2 + L^2 q^2}} \sin (qt - \alpha) + C e^{-\frac{Rt}{L}}$$

where C is a constant and $\tan \alpha = \frac{Lq}{R}$.

If $i = 0$ when $t = 0$, find the value of C , and plot a curve to show the value of i at any time from $t = 0$ to $t = 0.05$.

Given $R = 25$, $L = 0.1$, $E = 100$, $q = 600$.

232. The following differential equation may also be considered :—

$$\text{Let } \frac{dy}{dx} = n \frac{y}{x}$$

Find the law connecting y and x . We have, separating the variables and integrating

$$\int \frac{dy}{y} = n \int \frac{dx}{x}$$

$$\log_e y = n \log_e x + C$$

$$\therefore y = ax^n \text{ where } a = e^C$$

and may therefore have any arbitrary constant value.

EXAMPLE.—If a gas expands without gain or loss of heat it can be shown that

$$\frac{dp}{dv} = -\gamma \frac{p}{v}$$

Find the law connecting p and v .

As above, we have

$$\frac{1}{p} \cdot dp = -\gamma \frac{dv}{v}$$

\therefore integrating

$$\log_e p = -\gamma \log_e v + c$$

$$\therefore p = kv^{-\gamma} \text{ where } k \text{ is a constant}$$

$$\text{or } pv^\gamma = k$$

233. More General Case, where $\frac{dy}{dx}$ is given as a Function of y .—
Consider such an example as the following :—

$$\frac{dy}{dx} = y^2$$

$$\text{Then } \frac{dx}{dy} = \frac{1}{y^2}$$

$$\text{and } x = \int dx = \int \frac{dx}{dy} dy = \int \frac{dy}{y^2} = -\frac{1}{y} + C$$

So, in general, if

$$\begin{aligned} \frac{dy}{dx} &= f(y) \\ \frac{dx}{dy} &= \frac{1}{f(y)} \\ \therefore \int dx &= \int \frac{dy}{f(y)} \end{aligned}$$

and x can be found in terms of y if the function $\frac{1}{f(y)}$ can be integrated with respect to y .

If $\int \frac{dy}{f(y)}$ cannot be integrated directly, or if the connection between $\frac{dy}{dx}$ and y is given by means of a number of experimental results, we may obtain a solution by the graphic method.

EXAMPLE.—Let

$$\frac{dy}{dx} = \sqrt{(1-y^2)(1-0.25y^2)}$$

Construct a curve showing the relation between x and y from $y = 0$ to $y = \frac{1}{2}$, having given that $x = 0$ when $y = 0$.

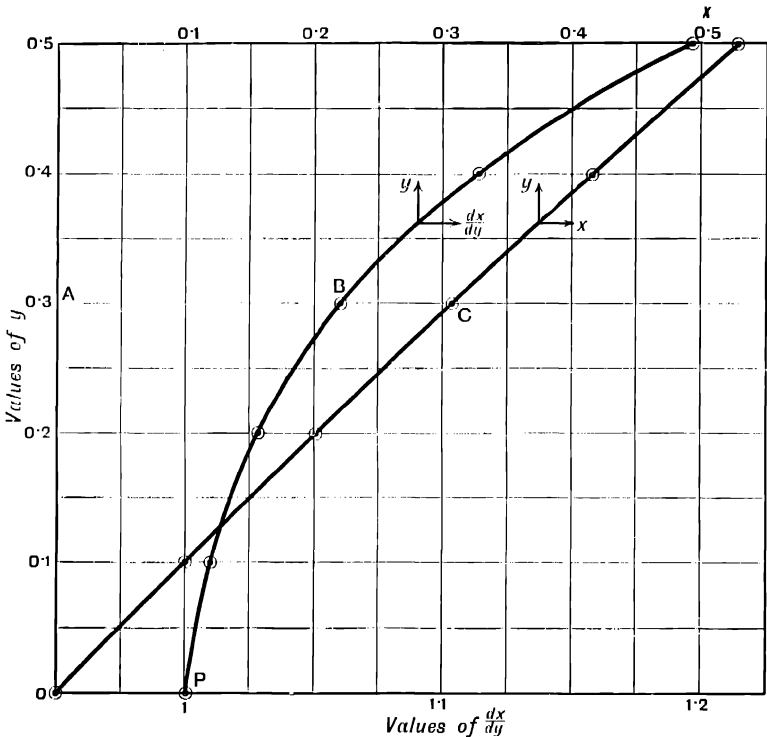

FIG. 199.

We have

$$\frac{dx}{dy} = \frac{1}{\sqrt{(1-y^2)(1-0.25y^2)}}$$

and $x = \int_0^x dx = \int_0^y \frac{dx}{dy} dy$ since $y = 0$ when $x = 0$

To find this integral we plot a curve in which values of y are ordinates and values of $\frac{dx}{dy}$ abscissæ by choosing a number of values of y and thence calculating the corresponding values of $\frac{dx}{dy}$.

This is the curve **PB** in the figure.

The value of $\int_0^y \frac{dx}{dy} dy$ for any value of y is the area lying between this curve and the axis of y from $y = 0$ to the value of y which is being considered.

E.g. the area **OABP** gives the value of $\int_0^y \frac{dx}{dy} dy$, and therefore of x when $y = \text{OA}$.

This is found to be 0.307, which is therefore the value of x when $y = \text{OA}$.

Setting off **AC** equal to 0.307, we get a point **C** on the required curve connecting x and y .

Proceeding in this way for a series of values of y we construct the curve **OC** in the figure, which shows the relation between x and y , so that the given differential equation may be satisfied.

234. We may also have the relation between $\frac{dy}{dx}$ and y given by means of the results of experiments as in the following example.

EXAMPLE.—The accelerating torque of an induction motor can be found when the speed is known. The following are values of the torque t_a available for acceleration at speeds v of a car on the City and South London Electric Railway.

v ft. per sec. . .	0	16	16.95	18.55	20	21.2
t_a inch-lbs. . .	7520	7520	5400	3000	1200	0

The torque is constant from $v = 0$ to $v = 16$, and then decreases.

The acceleration is proportional to the torque, and it is known that the acceleration is 0.463 ft. per sec. per sec. when t_a is 7520 inch-lbs.

Construct a curve to show the relation between speed and time from starting.

(Carus-Wilson, *Electro-Dynamics*, p. 163.)

Let a be the acceleration. Then, since the acceleration is proportional to the torque, and $a = 0.463$ when $t_a = 7520$, we have

$$a = \frac{0.463}{7520} t_a = 6.15 \times 10^{-5} t_a$$

and the values of a , which is equal to $\frac{dv}{dt}$, may be calculated. Hence we get the values of $\frac{dt}{dv}$ as follows:—

EXAMPLES.—CXXV.

1. The speed v of a car at a distance x from its starting-point is given by the following table:—

x feet . .	0	40	80	130	200	300
v ft. per sec.	0	7·2	12·2	18·8	25	29·5

In what time does the car get from $x = 100$ to $x = 300$?

NOTE.—The required time $= \int_{100}^{300} \frac{dt}{dx} dx = \int_{100}^{300} \frac{1}{v} dx$, which can be found by the graphic method from the above data.

2. The following table gives the acceleration a of an electric locomotive when the speed is v feet per second.

v ft. per sec.	0 to 26·28	27	29	32	34
a f. s. s. . .	Constant and = 0·73	0·495	0·285	0·090	0

Construct a curve to show the velocity at any time after starting.

3. The following data refer to a similar case:—

v ft. per sec.	0 to 37·4	38	39	40	42
a f. s. s. . .	0·417	0·300	0·190	0·105	0

Construct curves to show the relation between velocity and time from starting, and also between distance traversed and time.

4. P is the pull in pounds exerted at the tread of an electric locomotive at speed v feet per second after tractive resistance has been allowed for. The mass to be drawn is 3360 engineering units. Construct a curve to show the relation between velocity and time from starting.

v ft. per sec.	0 to 28·6	29	30	32	35·4
P lbs. . .	1960	1713	1273	605	0

5. The following table gives the speed of a car at various distances s from starting. Construct a curve showing the relation between the distance and the time from starting.

Velocity ft. per sec.	0	5	7.5	9.9	12.5	16.9
s ft.	0	35	70	120	180	300

(P. V. MacMahon, *Electrician*, June, 1899, p. 227.)

235. Linear Equations of the Second Order.—We shall first consider and compare the three differential equations.

$$\frac{d^2y}{dx^2} + 2\frac{dy}{dx} - 3y = 0 \dots\dots\dots (1)$$

$$\frac{d^2y}{dx^2} + 2\frac{dy}{dx} + 3y = 0 \dots\dots\dots (2)$$

$$\frac{d^2y}{dx^2} + 2\frac{dy}{dx} + y = 0 \dots\dots\dots (3)$$

We note that the equation

$$\frac{dy}{dx} - by = 0$$

has been shown to be satisfied by putting

$$y = Ae^{bx}$$

The equations which we are now considering are similar to equations of this type, but contain an additional term $\frac{d^2y}{dx^2}$ of higher order.

(1) We shall try whether a value of y of the form $y = Ae^{\lambda x}$, where A and λ are constants, can be made to satisfy the equations (1), (2), (3).

We have, if $y = Ae^{\lambda x}$,

$$\frac{dy}{dx} = A\lambda e^{\lambda x}; \quad \frac{d^2y}{dx^2} = A\lambda^2 e^{\lambda x} \dots\dots\dots (4)$$

Substituting in equation (1), we get

$$(\lambda^2 + 2\lambda - 3)Ae^{\lambda x} = 0$$

This is evidently satisfied if

$$\lambda^2 + 2\lambda - 3 = 0, \text{ and } \therefore \lambda = 1 \text{ or } -3$$

Therefore equation (1) is satisfied if we put

$$y = A_1e^x \text{ or } y = A_2e^{-3x}$$

where A_1 and A_2 are any constants.

$$\therefore y = A_1e^x + A_2e^{-3x} \dots\dots\dots (5)$$

also satisfies equation (1), since the sum of two functions can be differentiated one term at a time.

It can be shown that all possible solutions of equation (1) can be put into this form by giving different values to the constants A_1 and A_2 .

(2) If we attempt to solve equation (2) by the same process, we get on substituting from (4)

$$(\lambda^2 + 2\lambda + 3)\lambda e^{\lambda x} = 0$$

The equation $\lambda^2 + 2\lambda + 3 = 0$ has no real roots, so that in this case we cannot find two real values of λ to give a solution of the form (5).

If, however, we introduce the imaginary $\sqrt{-1} = i$ as in p. 66, we find, solving the quadratic in λ ,

$$\lambda = \frac{-2 \pm \sqrt{-8}}{2} = -1 \pm i\sqrt{2}$$

∴ the general solution is

$$\begin{aligned} y &= A_1 e^{-x+i\sqrt{2}x} + A_2 e^{-x-i\sqrt{2}x} \\ &= e^{-x}(A_1 e^{i\sqrt{2}x} + A_2 e^{-i\sqrt{2}x}) \\ &= e^{-x}(A_1 \cos \sqrt{2}x + A_1 i \sin \sqrt{2}x + A_2 \cos \sqrt{2}x \\ &\quad - A_2 i \sin \sqrt{2}x) \quad (\text{see p. 223}) \\ &= (C \sin \sqrt{2}x + D \cos \sqrt{2}x)e^{-x} \end{aligned}$$

where $D = A_1 + A_2$, $C = A_1 i - A_2 i$.

Note that as A_1, A_2 may have any values, real or imaginary, C may be real, and C and D are constants.

We have shown (p. 42) that

$$C \sin \sqrt{2}x + D \cos \sqrt{2}x$$

may be expressed in the form $A \sin(\sqrt{2}x + B)$.

Therefore the general solution of the equation (2) is

$$y = A e^{-x} \sin(\sqrt{2}x + B) \dots \dots \dots (6)$$

where A and B are constants.

(3) In equation (3) we get, on substituting $y = A e^{\lambda x}$,

$$(\lambda^2 + 2\lambda + 1)\lambda e^{\lambda x} = 0$$

This is satisfied if $\lambda^2 + 2\lambda + 1 = 0$

$$\text{i.e. } (\lambda + 1)^2 = 0; \lambda = -1$$

Thus $y = A e^{-x}$ will satisfy the equation, but this solution only contains one arbitrary constant A instead of two, as in cases (1) and (2).

It can be shown that the complete solution of a differential equation containing $\frac{d^2y}{dx^2}$ must contain two arbitrary constants.

We find that the equation is satisfied by putting

$$y = (A + Bx)e^{-x} \dots \dots \dots (7)$$

For $\frac{dy}{dx} = -Ae^{-x} + Be^{-x} - Bxe^{-x}$

$$\frac{d^2y}{dx^2} = (A - 2B)e^{-x} + Bxe^{-x}$$

$$\therefore \frac{d^2y}{dx^2} + 2\frac{dy}{dx} + y = (A - 2B - 2A + 2B + A)e^{-x} + (B - 2B + B)xe^{-x} = 0$$

236. The equations (1), (2), (3) are all of the form

$$\frac{d^2y}{dx^2} + a\frac{dy}{dx} + by = 0. \dots \dots \dots (8)$$

where a and b are constants.

We thus find that there are three forms of the solution.

If the quadratic

$$\lambda^2 + a\lambda + b = 0$$

has two unequal roots λ_1, λ_2 , the solution is in the form

$$y = A_1e^{\lambda_1x} + A_2e^{\lambda_2x} \text{ as in (5)}$$

If the quadratic has imaginary roots the solution takes the form

$$y = Ae^{px} \sin(qx + l) \text{ as in (6)}$$

where the roots of the quadratic are

$$\lambda = p \pm iq = \frac{-a \pm i\sqrt{4b - a^2}}{2}$$

and therefore the solution is

$$y = Ae^{-\frac{a}{2}x} \sin\left(\sqrt{b - \frac{a^2}{4}}x + B\right) \dots \dots \dots (9)$$

If the quadratic has equal roots λ , the solution is $y = (A + Bx)e^{\lambda x}$.

The student is advised not to use the general formulae, but to work out each case separately as has been done for equations (1), (2), (3) above.

237. Simple Harmonic Motion.—An important special case arises when $a = 0$ in equation (8).

We get

$$\frac{d^2y}{dx^2} + by = 0$$

The solution (9) becomes

$$y = A \sin(\sqrt{bx} + B)$$

The case of simple harmonic motion is represented by a differential equation of this form.

Let a point move along a straight line so that its acceleration towards a fixed point O is proportional to its distance from that point.

Let x be the distance of the moving point from O at any time t .

Then the above condition gives

$$\frac{d^2x}{dt^2} = -q^2x \text{ where } q \text{ is a constant}$$

$$\text{or } \frac{d^2x}{dt^2} + q^2x = 0$$

The solution of this differential equation is

$$x = A \sin(qt + g)$$

where g is a constant.

This gives the distance x described in time t in simple harmonic motion.

This is the same as the equation obtained to represent simple harmonic

motion in the graphic treatment in Chapter VII., where simple harmonic motion was defined as the projection of uniform circular motion.

We thus see that the definition of simple harmonic motion by means of the property that the acceleration varies as the distance from the centre leads to the same result as its definition as the projection on a straight line of uniform circular motion.

238. EXAMPLE.—*A condenser of capacity K is discharging through a circuit of resistance R and coefficient of self-induction L ; its potential v at any time t satisfies the differential equation*

$$L \frac{d^2v}{dt^2} + R \frac{dv}{dt} + \frac{v}{K} = 0 \quad \dots \dots \dots (1)$$

Find an expression for the potential at any time.

We have seen that the solution of this equation depends upon that of the quadratic

$$L\lambda^2 + R\lambda + \frac{1}{K} = 0 \quad \dots \dots \dots (2)$$

If $R^2 > \frac{4L}{K}$; i.e. if $4L < R^2K$, this quadratic has real roots, and the differential equation is of the same type as equation (1), p. 388.

Let λ_1, λ_2 be the roots of the quadratic equation (2).

Then the solution of the differential equation (1) is

$$v = A_1 e^{\lambda_1 t} + A_2 e^{\lambda_2 t}$$

If $R^2 < \frac{4L}{K}$; i.e. if $4L > R^2K$, the quadratic has imaginary roots, and the equation is of the same type as equation (2), p. 388.

Its solution is

$$v = A e^{-\frac{R}{2L}t} \sin\left(\sqrt{\frac{1}{KL} - \frac{R^2}{4L^2}}t + B\right)$$

If $4L = R^2K$ we have equal roots as in equation (3), p. 388, and

$$v = (A + Bt)e^{-\frac{R}{2L}t}$$

239. The constants in any actual case are found from the known initial conditions.

Consider the case where $R = 200$ ohms and $K = 0.5$ microfarad = 0.5×10^{-6} farad.

First take $L = 0.002$ henry.

Then the differential equation becomes

$$0.002 \frac{d^2v}{dt^2} + 200 \frac{dv}{dt} + 2 \times 10^6 v = 0$$

Substitute $v = A e^{\lambda t}$.

We get, as the condition that the differential equation may be satisfied

$$\begin{aligned} & 0.002\lambda^2 + 200\lambda + 2 \times 10^6 = 0 \\ \lambda &= \frac{-200 \pm \sqrt{4 \cdot 10^4 - 1.6 \cdot 10^8}}{4 \times 10^{-3}} \\ &= -10^4(5 \pm 3.875) = -8.875 \cdot 10^4 \text{ or } -1.125 \cdot 10^4 \end{aligned}$$

\therefore the potential to which the condenser is charged at any time t is given by

$$v = A_1 e^{-8.875 \cdot 10^4 t} + A_2 e^{-1.125 \cdot 10^4 t}$$

To find the values of the constants A_1 and A_2 the initial conditions must be given. Suppose the condenser is charged to 1000 volts when $t = 0$.

Substituting, we have

$$1000 = A_1 + A_2$$

We also know that the current and therefore $\frac{dv}{dt} = 0$ when $t = 0$.

We have

$$\frac{dv}{dt} = -8.875 \cdot 10^4 \cdot A_1 e^{-8.875 \cdot 10^4 t} - 1.125 \cdot 10^4 \cdot A_2 e^{-1.125 \cdot 10^4 t}$$

\therefore substituting $t = 0$ and $\frac{dv}{dt} = 0$, and simplifying, we get

$$0 = -71A_1 - 9A_2$$

$$\therefore A_1 = -\frac{9 \cdot 0.02}{6.2} = -145, A_2 = 1145$$

\therefore the solution is

$$v = 1145 e^{-1.125 \cdot 10^4 t} - 145 e^{-8.875 \cdot 10^4 t}$$

The curve representing this equation has been plotted as an example in Example 7, p. 110.

Next suppose R and K have the same values as before, but $L = 0.01$. The quadratic in λ becomes

$$0.01\lambda^2 + 200\lambda + 2 \times 10^0 = 0$$

$$\lambda = \frac{-200 \pm \sqrt{4 \cdot 10^4 - 8 \cdot 10^1}}{0.02}$$

$$= -10^4(1 \pm i)$$

\therefore the potential at any time is given by

$$v = A e^{-10^4 t} \sin(10^4 t + B)$$

To find the constants, we have

$$v = 1000 \text{ when } t = 0$$

$$\therefore 1000 = A \sin B$$

Also, as before, $\frac{dv}{dt} = 0$ when $t = 0$.

$$\frac{dv}{dt} = -10^4 A e^{-10^4 t} \sin(10^4 t + B) + 10^4 A e^{-10^4 t} \cos(10^4 t + B)$$

Substituting $\frac{dv}{dt} = 0$ and $t = 0$, we get

$$0 = 10^4 A \cos B - 10^4 A \sin B$$

$$\therefore \sin B = \cos B \text{ and } \tan B = 1$$

$$\therefore B = \frac{\pi}{4} = 0.7854$$

$$\text{and } 1000 = A \sin \frac{\pi}{4} = \frac{A}{\sqrt{2}} \quad \therefore A = 1414$$

∴ the value of v at any time is given by

$$z = 1414e^{-10^4 t} \sin(10^4 t + 0.7854)$$

The curve representing this solution was given as an example in Example 4, p. 120.

As an example the student should work out the solution numerically and plot the curve for the case when $L = 0.005 = \frac{R^2 K}{4}$, the initial conditions being the same as in the above examples.

EXAMPLES.—CXXVI.

Find the relations between y and x , so that the following equations may be satisfied:—

1. $\frac{d^2 y}{dx^2} + 5\frac{dy}{dx} + 4y = 0$. Taking each of the constants equal to unity, plot a curve to show the relation between y and x from $x = 0$ to $x = 2$.

2. $\frac{d^2 y}{dx^2} - 5\frac{dy}{dx} + 4y = 0$.

3. $\frac{d^2 y}{dx^2} + \frac{dy}{dx} - 6y = 0$.

4. $\frac{d^2 y}{dx^2} + 4\frac{dy}{dx} + 4y = 0$.

5. $\frac{d^2 y}{dx^2} + 4\frac{dy}{dx} + 5y = 0$.

6. $\frac{d^2 y}{dx^2} + 16y = 0$.

7. A mass m is supported by a vertical spring which will stretch a length h when supporting 1 lb. Then, if we neglect the stiffness of the spring and the resistance of the air, the motion is given by

$$m\frac{d^2 x}{dt^2} + \frac{x}{h} = 0$$

where m is obtained by dividing the weight in pounds by 32.2 , and x feet is the distance of the weight from its position of equilibrium at time t seconds. Find an expression for x in terms of t , having given that $x = 0$ when $t = 0$. Taking the weight equal to $\frac{1}{4}$ lb., $h = 0.5$ ft., and the greatest value of x 9 ins., plot a curve to show the displacement at any time from $t = 0$ to $t = 1$ sec. How long does it take the weight to make a complete oscillation in the numerical case?

8. If the stiffness of the spring and the resistance of the air in Example 7 have the effect of retarding the motion with a force proportional to the velocity, the motion is given by

$$m\frac{d^2 x}{dt^2} + k\frac{dx}{dt} + \frac{x}{h} = 0$$

k is the retarding force when the velocity is unity. Find an expression for x in terms of t for the case where the weight = $\frac{1}{4}$ lb., $h = 0.5$ ft., and $k = 0.02$ lb. Sketch a curve to show roughly the character of the motion.

9. I is the moment of inertia of a ballistic galvanometer needle round its axis of rotation. h is the twisting moment per unit angular displacement due to the torsion of the fibre and the controlling magnetic field, k is the moment of retarding force per unit angular velocity of the oil bath used to damp the motion. The motion is given by

$$I\frac{d^2 \theta}{dt^2} + k\frac{d\theta}{dt} + h\theta = 0$$

where θ is the angle through which the needle is displaced from its equilibrium position at time t .

Find an expression for θ in terms of t

1st, when $k^2 < 4lh$; 2nd, when $k^2 > 4lh$

Sketch figures to illustrate the character of the motion in each case.

Note that in the second case the motion is "dead-beat," i.e. the needle does not swing back past its equilibrium position, while in the first case the motion is oscillatory.

240. Next consider a differential equation of the type

$$\frac{d^2y}{dx^2} + a\frac{dy}{dx} + by = C \quad \dots \dots \dots (1)$$

where C is a constant.

Compare this with the equation

$$\frac{d^2y}{dx^2} + a\frac{dy}{dx} + by = 0 \quad \dots \dots \dots (2)$$

which has already been considered.

If $y = u$ is a solution of equation (2), then $y = u + \frac{C}{b}$ is a solution of (1).

For if $y = u + \frac{C}{b}$

$$\text{we have } \frac{dy}{dx} = \frac{du}{dx}, \quad \frac{d^2y}{dx^2} = \frac{d^2u}{dx^2}$$

and, on substitution,

$$\begin{aligned} \frac{d^2y}{dx^2} + a\frac{dy}{dx} + by &= \frac{d^2u}{dx^2} + a\frac{du}{dx} + bu + C \\ &= C \end{aligned}$$

since $y = u$ is a solution of (2)

EXAMPLE.—

$$\frac{d^2y}{dx^2} + 2\frac{dy}{dx} - 3y = 9$$

We have shown, p. 388, that the solution of

$$\frac{d^2y}{dx^2} + 2\frac{dy}{dx} - 3y = 0$$

$$\text{is } y = A_1e^x + A_2e^{-3x}$$

Therefore the solution of the given equation is

$$y = A_1e^x + A_2e^{-3x} - 3$$

This may be verified by finding $\frac{dy}{dx}$ and $\frac{d^2y}{dx^2}$ and substituting.

EXAMPLES.—CXXVII.

1. Find the relation between y and t which satisfies the differential equation

$$5\frac{d^2y}{dt^2} + 4\frac{dy}{dt} + 4y = 16$$

Verify by finding $\frac{dy}{dt}$ and $\frac{d^2y}{dt^2}$, and substituting.

2. If a constant electromotive force of 1000 volts is applied to a circuit containing a self-induction L , a resistance R , and a condenser of capacity K , then the quantity q of the charge in the condenser at time t satisfies the equation

$$L\frac{d^2q}{dt^2} + R\frac{dq}{dt} + \frac{q}{K} = 1000$$

Giving R and K the same numerical values as in § 239, find expressions for q in terms of the time for the two cases when $L = 0.002$ henry and $L = 0.01$ henry, having given that $q = 0$ when $t = 0$, and $\frac{dq}{dt} = 0$ when $t = 0$.

NOTE.—With the data as given the result will give the value of q in coulombs.

BOARD OF EDUCATION EXAMINATION PAPERS

ADVANCED STAGE.

1901.

1. Compute $30.56 \div 4.105$, 0.03056×0.4105 , $4.105^{1.23}$, $0.04105^{-2.3}$.

The answers must be right to three significant figures.

Why do we multiply $\log a$ by b to obtain the logarithm of a^b ? (20)

2. If $a = 5$, $b = 200$, $c = 600$, $g = -0.1745$ radian, find the value of $ae^{-bt} \sin(ct + g)$
- (i) when $t = 0.001$
 - (ii) when $t = 0.01$
 - (iii) when $t = 0.1$.

Of course the angle is in radians. (20)

3. The keeper of a restaurant finds, when he has G guests in a day, his total daily expenditure is E pounds (for rent, taxes, wages, wear and tear, food and drink), and his total daily receipt is R pounds. The following numbers are averages obtained by examination of his books on many days :—

G	E	R
210	16.7	15.8
270	19.4	21.2
320	21.6	26.4
360	23.4	29.8

Using squared paper, find E and R and the day's profits if he has 340 guests.

What number of guests per day just gives him no profit?

What simple algebraic laws seem to connect E , R , P the profit, and G ?

Two of the marks will be given for a correct answer to the following :—

If he finds that he has almost too many guests from, say, 1 to 2 o'clock, and from, say, 6 to 7 o'clock, and almost none at other times of the day, what expedient might he adopt to increase his profits? (25)

4. The following quantities are thought to follow a law like $pv^n = \text{constant}$. Try if they do so; find the most probable value of n :—

v	1	2	3	4	5
p	205	114	80	63	52

5. There is a curve whose shape may be drawn from the following values of x and y

x in feet . .	3	3.5	4.2	4.8
y in inches .	10.1	12.2	13.1	11.9

Imagine this curve to rotate about the axis of x describing a surface of revolution. What is the volume enclosed by this surface and the two end sections where $x = 3$ and $x = 4.8$? (25)

6. If $x = a \sin pt + b \cos pt$ for any value of t where a , b , and p are mere numbers; show that this is the same as $x = A \sin (pt + c)$ if A and c are properly evaluated. (25)
7. Let a closed curve rotate round a straight line in its own plane and generate a ring; state and prove the two rules for finding the volume and surface of the ring. (25)
8. Two sides of a triangle are measured and found to be 32.5 and 24.2 ins.; the included angle being 57° , find the area of the triangle. Prove the rule used by you. If the true lengths of the sides are really 32.6 and 24.1, what is the percentage error in the answer? (20)
9. The polar co-ordinates of a point are $r = 5$ ft., $\theta = 52^\circ$; $\phi = 70^\circ$, find the x , y , and z co-ordinates; also find the angles made by r with the axes of co-ordinates. (25)
10. Define carefully what is meant by the Scalar Product of two vectors and by the Vector Product of two vectors, giving one useful example of each. (30)
11. There is a piece of a mechanism whose weight is 200 lbs. The following values of s in feet show the distance of its centre of gravity (as measured on a skeleton drawing) from some point in its straight path at the time t seconds from some era of reckoning. Find its acceleration at the time $t = 2.05$, and the force in pounds which is giving this acceleration to it.

s	t
0.3090	2.00
0.4931	2.02
0.6799	2.04
0.8701	2.06
1.0643	2.08
1.2631	2.10

(25)

12. What is meant by the symbol $\frac{dy}{dx}$? Explain how it may be represented by the slope of a curve. State its value in the cases

$$y = ax^n, y = ae^{bx}, y = a \sin (bx + c), y = a \cos (bx + c), y = \log_e (x + b). \quad (30)$$

13. Find

$$\int p \cdot dv, \text{ if } pv^n = c, \text{ a constant}$$

- (1) when $n = 0.8$,
- (2) when $n = 1$.

(25)

14. In the curve $y = cx^{\frac{1}{2}}$, find c if $y = m$ when $x = b$. Let this curve rotate about the axis of x ; find the volume enclosed by the surface of revolution between the two sections at $x = a$ and $x = b$. Of course m , b , and a are given distances. (25)

15. The rate (per unit increase of volume) of reception of heat by a gas is h , p is its pressure, and v its volume; γ is a known constant.

If $p v^{\gamma} = c$, γ and c being constants, find h if

$$h = \frac{1}{\gamma - 1} \left\{ v \frac{dp}{dv} + \gamma p \right\}.$$

Full marks will be given only when the answer is stated in its simplest form.

If h is always 0, find what γ must be. (25)

16. At the following draughts in sea water a particular vessel has the following displacements:—

Draught h feet . . .	15	12	9	6.3
Displacement T tons .	2098	1512	1018	586

Plot $\log T$ and $\log h$ on squared paper, and try to get a simple rule connecting T and h . If one ton of sea water measures 35 cub. ft., find the rule connecting V and h , if V is the displacement in cubic feet. (25)

17. Preferably to be answered by a Candidate who has already answered Question 16. Find how A the horizontal sectional area of the vessel at the water line depends upon h . At any draught h , what change of displacement V or T is produced by one *inch* difference in h ? (20)

18. In any class of turbine if P is power of the waterfall and H the height of the fall, n the rate of revolution, and R is the average radius at the place where water enters the wheel, then it is known that for any particular class of turbines of all sizes,

$$n \propto H^{1.25}, P^{-0.5}$$

$$R \propto P^{0.5}, H^{-0.75}$$

In the list of a particular maker I take a turbine at random for a fall of 6 feet, 100 horse-power, 50 revolutions per minute, 2.51 ft. radius. By means of this I find I can calculate n and R for all the other turbines of the list. Find n and R for a fall of 20 ft. and 75 horse-power. (20)

ADVANCED STAGE.

1902.

1. Compute by contracted methods, without using logarithms,

$$23.07 \times 0.1354, 2307 \div 1.354$$

Compute $2.307^{0.65}$ and $23.07^{-1.25}$ using logarithms. The answers to consist of four significant figures.

Why do we add logarithms to obtain the logarithm of a product?

Suppose we have a scale on a slide rule on which, as usual, the distance to any mark n is $\log n$; and there is another scale on which the distance to any mark m is $\log(\log m)$; show that we can at once read off m^n and also the logarithm of any number to any base. (20)

2. Write in a table the values of the sine, cosine, and tangent of the following angles :—

$$23^\circ, 123^\circ, 233^\circ, 312^\circ, 383^\circ \quad (20)$$

3. What is meant by the symbol $\frac{dy}{dx}$?

Explain how it may be represented by the slope of a curve.

If $y = 2.4 - 1.2x + 0.2x^2$ find $\frac{dy}{dx}$ and plot two curves from $x = 0$ to $x = 4$, showing how y and $\frac{dy}{dx}$ depend upon x . (20)

4. Work the following three exercises as if in each case one were alone given, taking in each case the simplest supposition which your information permits :—
 (a) The total yearly expense in keeping a school of 100 boys is £2,100; what is the expense when the number of boys is 175?
 (b) The expense is £2100 for 100 boys, £3050 for 200 boys; what is it for 175 boys?
 (c) The expenses for three cases are known as follows :—

£2100 for 100 boys
 £2650 for 150 boys
 £3050 for 200 boys

What is the probable expense for 175 boys?

If you use a squared paper method, show all three solutions together. (25)

5. For the years 1896–1900, the following average numbers are taken from the accounts of the 34 most important electric companies of the United Kingdom. U means millions of units of electric energy sold to customers. C means the total cost in millions of pence, and includes interest (7 per cent.) on capital, maintenance, rent, taxes, salaries, wages, coal, etc.

U	0.67	1.00	1.366	1.46	2.49
C	4.84	6.25	8.60	9.11	14.25

Is there any simple approximately correct law connecting U and C? If so, what is it? Assume that from the beginning there was the idea of, at some time, reaching a maximum output of 13.9, so that $U \div 13.9$ is called f , a certain kind of *load factor*. Let $C \div U$ be called c the total cost per unit; is there any law connecting c and f ? You need not plot c and f ; it is better to use the law already found. (30)

6. In some experiments in towing a canal boat the following observations were made; P being the pull in pounds and v the speed of the boat in miles per hour.

v	1.68	2.43	3.18	3.60	4.03
P	76	160	240	320	370

Plot $\log v$ and $\log P$ upon squared paper, and give an approximate formula connecting P and v . (20)

7. What is the idea on which compound interest is calculated? Explain, as if to a beginner, how it is that

$$A = P \left(1 + \frac{r}{100} \right)^n$$

where P is the money lent and A is what it amounts to in n years at r per cent. per annum. If A is 130 and P is 100 and n is 7.5, find r .

What does the above equation become when we imagine interest to be added on to principal every instant? State two natural phenomena which follow the compound interest law. (30)

8. Only one of the following, (a) or (b), is to be attempted:—

(a) The inside diameter of a hollow sphere of cast-iron is the fraction 0.57 of its outside diameter. Find these diameters if the weight is 60 lbs. Take 1 cub. in. of cast iron as weighing 0.26 lb.

If the outside diameter is made 1 per cent. smaller, the inside not being altered, what is the percentage diminution in weight?

(b) The cross-section of a ring is an ellipse whose principal diameters are 2 ins. and $1\frac{1}{2}$ ins.; the middle of this section is at 3 ins. from the axis of the ring. What is the volume of the ring?

Prove the rule you use for finding the volume of any ring. (20)

9. If pv^k is constant, and if $p = 1$ when $v = 1$, find for what value of v , p is 0.2. Do this for the following values of k : 0.8, 0.9, 1.0, 1.1. Tabulate your answers. (25)

10. Define carefully what is meant by the Scalar Product and by the Vector Product of two vectors, giving one useful example of each. (25)

11. There is a point P whose x , y , and z co-ordinates are 2, 1.5, and 3. Find its r , θ , ϕ co-ordinates. If O is the origin, find the angles made by OP with the axes of co-ordinates. (20)

12. When is $x^\gamma - x^{1+\frac{1}{\gamma}}$ a maximum, γ being 1.4? Plot the values near the maximum value. For this purpose you need only calculate the maximum value and two others. (25)

13. If the current C amperes in a circuit follows the law $C = 10 \sin 600t$; if t is in seconds; and if

$$V = RC + L \frac{dC}{dt},$$

where R is 0.3 and L is 4×10^{-4} , what is V ?

Show by a sketch how C and V depend upon time, and particularly how one lags behind the other, and also state their highest and lowest values. (30)

14. There is a function

$$y = 5 \log_{10} x + 6 \sin \frac{1}{10} x + 0.084(x - 3.5)^2$$

Find a much simpler function of x which does not differ from it in value more than 2 per cent. between $x = 3$ and $x = 6$. Remember that the angle $\frac{1}{10}x$ is in radians. (25)

ADVANCED STAGE.

1903.

1. Compute by contracted methods to four significant figures only, and without using logarithms or slide rule

$$8.102 \times 35.14, 254.3 \div 0.09027$$

State the logarithms of 37240, 37·24, 0·03724.
 Compute, using logarithms,

$$\sqrt[3]{37\cdot24} \qquad \sqrt[3]{3\cdot724}$$

$$372\cdot4^{2\cdot43} \qquad 0\cdot3724^{-2\cdot43}$$

Explain why it is that logarithms are multiplied in computing the powers of numbers.

In using your four-figure logarithm table have you observed that there is more chance of error at some places than at others? How is this? Can you suggest an improvement in such tables? (30)

2. The three parts (a), (b), and (c) must be all answered to get full marks.

(a) If $\theta = 0\cdot8\pi$, $\mu = 0\cdot3$, and $N = Me^{\mu\theta}$;

$$\text{if } (N - M) V = 33000 P ;$$

$$\text{if } P \text{ is } 30 \text{ and } V \text{ is } 520 ;$$

find N .

(b) Find the value of $10e^{-0\cdot2t} \sin(2\pi f t + 0\cdot6)$, where f is 225 and t is 0·003.
 Observe that the angle is stated in *radians*.

(c) If

$$A = P \left(1 + \frac{r}{100} \right)^n,$$

and if

$$A = 3P \text{ when } r = 3\frac{1}{2}$$

find n .

(30)

3. $y = a + bx^n$ is the equation to a curve which passes through these three points,

$$x = 0, y = 1\cdot24; \quad x = 2\cdot2, y = 5\cdot07; \quad x = 3\cdot5, y = 12\cdot64$$

find a , b , and n .

When we say that $\frac{dy}{dx}$ is shown by the slope of the curve, what exactly do we mean? Find $\frac{dy}{dx}$, when $x = 2$. (30)

4. The following are the areas of cross-section of a body at right angles to its straight axis:—

A in sq. ins. . . .	250	292	310	273	215	180	135	120
x inches from one end	0	22	41	70	84	102	130	145

What is the whole volume from $x = 0$ to $x = 145$?

At $x = 50$, if a cross-sectional slice of small thickness δx has the volume δv ,

find $\frac{\delta v}{\delta x}$. (30)

5. Find accurately to three significant figures a value of x to satisfy the equation

$$0\cdot5x^{1\cdot3} - 12 \log_{10} x + 2 \sin 2x = 0\cdot921$$

Notice in $\sin 2x$ that the angle is in radians.

(42)

6. The population of a country was 4.35×10^6 in 1820, 7.5×10^6 in 1860, 11.26×10^6 in 1890. Test if the population follows the compound interest law of increase. What is the probable population in 1910? (30)
7. The following table records the growth in stature of a girl A (born January, 1890), and a boy B (born May, 1894). Plot these records. Heights were measured at intervals of four months.

TABLE OF HEIGHTS IN INCHES.

Year	1900	1901			1902			1903
Month	Sept.	Jan.	May	Sept.	Jan.	May	Sept.	Jan.
A	54.75	55.55	56.6	57.95	59.2	60.2	60.9	61.3
B	48.25	49.0	49.75	50.6	51.5	52.3	53.1	53.9

Find in inches per annum, the average rates of growth of A. and B. during the whole period of tabulation. What will be the probable heights of A. and B. at the end of another four months? Plot the *rate* of growth of A. at all times throughout the period. At about what age was A. growing most rapidly and what was her quickest rate of growth? (30)

8. The New Zealand Pension law for a person who has already lived from the age of 40 to 65 in the colony is:—

If the private income I is not more than £34 a year, the pension P is £18 a year. If the private income is anything from 34 to 52, the pension is such that the total income is just made up to 52. If the private income is 52 or more there is no pension.

Show on squared paper, for any income I the value of P , and also the value of the total income. If a person's private income is say £50, how much of it has he an inducement to give away before he applies for a pension? Show on the same paper the total income, if the pension were regulated according to the rule

$$P = 18 - \frac{9}{26}I \quad (30)$$

9. The following table gives corresponding values of two quantities x and y :—

y	10.16	12.26	14.70	20.80	24.54	28.83
x	37.36	31.34	26.43	19.08	16.33	14.04

Try whether x and y are connected by a law of the form $yx^n = c$, and if so, determine as nearly as you can the values of n and c .

What is the value of x when $y = 17.53$? (30)

10. Both parts (a) and (b) must be answered to get full marks.

(a) Prove the rules used in finding the volume and area of a ring. The mean radius of a ring is 2 feet. The cross section of the ring is an ellipse

whose major and minor diameters are 0.8 and 0.5 ft. : what is its volume?

- (b) The length of a plane closed curve is divided into 24 elements, each 1 in. long. The middles of successive elements are at the distances x from a line in the plane, as follows (in inches) :—10, 10.5, 10.91, 11.24, 11.49, 11.67, 12.57, 11.67, 11.49, 11.24, 10.91, 10.5, 10, 10.5, 10.91, 11.24, 11.49, 11.67, 12.57, 11.67, 11.49, 11.24, 10.91, 10.5.

If the curve rotates about the line as an axis describing a ring, find approximately the area of the ring. (42)

11. Three planes of reference, mutually perpendicular, meet at O. The distances of a point P from the three planes are $x = 1.2$, $y = 2.7$, $z = 0.9$. The distances of a point Q are $x = 0.8$, $y = 1.8$, $z = 1.5$.

Find 1st, the distances OP and OQ ;

2nd, the distance PQ ;

3rd, the angle between OP and OQ. (30)

12. Find the moment of inertia of a hollow right circular cylinder, internal radius R_1 , external R_2 , length l , about the axis of figure.

Prove the rule by which, when we know the moment of inertia of a body about an axis through its centre of mass we find its moment of inertia about any parallel axis.

What is the moment of inertia of our hollow cylinder about an axis lying in its interior surface? (42)

13. If the current C amperes in a circuit follows the law

$$C = 10 \sin 600t$$

where t is in seconds. If

$$V = RC + L \frac{dC}{dt}$$

where $R = 0.3$, $L = 4 \times 10^{-4}$, find V .

Show by a sketch how C and V vary with the time t , and particularly how one lags behind the other, and also state their highest and lowest value. (42)

14. The entropy ϕ ranks of a quantity of stuff at the absolute temperature t degrees is known to vary in the following way :—

t	443	403	373	343
ϕ	1.584	1.668	1.749	1.850

Plot ϕ horizontally and t vertically.

A rectangle whose dimension horizontally represents 0.1 rank, and whose vertical dimension represents 10 degrees, has an area which represents 0.1 \times 10 or 1 unit of heat, what heat does each square inch of your diagram represent? The total heat received from beginning to end of the above set of changes is represented by the total area between the curve, the two end verticals and the zero line of temperature ; state the amount of it.

You need not, of course, plot the whole of ϕ ; you may subtract, say, 1.5 from each of the ϕ -values. Also, if you want greater accuracy and can estimate areas of rectangles not actually drawn, you need not plot the whole value of t . (42)

1904.

STAGE 2.

Answer Questions No. 1, No. 2, and No. 3, and five others.

1. The four parts (a), (b), (c), and (d) must all be answered to get full marks.
 (a) Compute by contracted methods to four significant figures only, and without using logarithms,

$$34'05 \times 0'009123; \text{ and } 3'405 \div 0'09123.$$

- (b) Compute, using logarithms, $\sqrt[3]{0'2354 \times 16'07}$; $(32'15)^{0'152}$; $(32'15)^{-0'162}$.
 (c) Explain why we add logarithms when we wish to multiply numbers.
 (d) Write down the value of $\sin 23^\circ$ and $\cos 23^\circ$. What is the sum of the squares of these? Explain why you would get the same answer whatever the angle. (20)

2. The two parts (a) and (b) must both be answered to get full marks.

- (a) Express the angle $0'3$ radians in degrees; find from the tables its sine. If x is in radians and if

$$\sin x = x - \frac{x^3}{3} + \frac{x^5}{5} - \frac{x^7}{7} + \text{etc.}$$

calculate the sine of this angle to four significant figures. After how many terms are more of them useless in this case when we only need four figures?

[Note that $\underline{5}$ means $1 \times 2 \times 3 \times 4 \times 5$.]

- (b) It has been found that if P is the horse-power wasted in air friction when a disc d feet diameter is revolving at n revolutions per minute,

$$P = c d^{5.5} n^{3.5}.$$

If P is $0'1$ when $d = 4$ and $n = 500$, find the constant c .

What is the diameter of a disc which wastes 10 horse-power in air friction when revolving at 580 revolutions per minute? (20)

3. The four parts (a), (b), (c), and (d) must all be answered to get full marks.

- (a) A hollow circular cylinder of length l , inside radius r , outside radius R , write out a formula for its volume V .

If $V = 182$ cubic inches, $l = 7'23$ inches, $r = 2'11$ inches, find R .

- (b) The sum of the areas of two squares is $92'14$ square inches, the sum of their sides is 13 inches; find these sides.

- (c) ABC is a triangle, C being a right angle. AB is $9'82$ inches, the angle A is 28° . Find the sides BC and AC, using the tables.

- (d) The area of cross-section * of a prism is $92'30$ square inches; what is the area of a section making an angle of 25° with the cross-section?

* The cross-section is the smallest section. (20)

4. Find accurately to three significant figures the value of x which satisfies the equation

$$3x^2 - 20 \log_{10} x - 7'077 = 0.$$

Use squared paper.

(30)

5. At corresponding high speeds of modern ships of the same class if v is the speed in knots, D the displacement in tons, P the indicated horse-power, T the time spent in a particular passage, and C the coal consumed,

$$v \propto D^{\frac{1}{2}}, P \propto D^{\frac{3}{2}}, T \propto D^{-\frac{1}{2}}, C \propto D.$$

A cross-Atlantic steamer of 10,000 tons at 20 knots crosses in 6 days, its power being 20,000, using 2520 tons of coal ; what must be the displacement, the speed, the power, and the coal for a vessel which makes the passage in 5 days? (20)

6. There is a district in which the surface of the ground may be regarded as a sloping plane ; its actual area is 3.246 square miles ; it is shown on the map as an area of 2.875 square miles ; at what angle is it inclined to the horizontal? Prove the truth of the rule which you use. (20)

7. At the following draughts h feet, a particular vessel has the following tonnage T in the salt-water :—

h	15	12	9	6.3
T	2100	1510	1020	590

Try if there is an approximate connection of the form

$$T = ch^n$$

and if so find c and n .

If a cubic foot of salt water weighs 64 lbs., find a formula connecting D , the displacement in cubic feet, and h . (30)

8. If

$$y = 2x + \frac{1.5}{x},$$

state what value of x will make y less than any other. An approximate answer, using squared paper, will gain as many marks as the correct answer. (20)

9. The following tests were made upon a condensing steam-turbine-electric-generator. There are probably some errors of observation, as the measurement of the steam is troublesome.

Output in Kilowatts K .	Weight W lb. of steam consumed per hour.
1190	23,120
995	20,040
745	16,630
498	12,560
247	8,320
0	4,065

Find if there is a simple approximate law connecting K and W , and state what it is algebraically.

State in words what $\frac{W}{K}$ means. Call this w . Express w in terms of K .

Calculate w for $K = 1000$ and $K = 300$.

(30)

10. At the time t seconds a body has moved x feet along its path from some fixed point in it. These positions have been found from a skeleton drawing of

a mechanism. Find the average speed in each interval. Find also the acceleration in the path at each instant approximately.

t	0	0.1	0.2	0.3	0.4	0.5	0.6
x	0	4	8.175	12.558	17.187	22.074	27.306

(20)

11. Assuming the earth to be a sphere, if its circumference is 360×60 nautical miles, what is the circumference of the parallel of latitude 50° ? What is the length there of a degree of longitude? If a small map is to be drawn in this latitude, with north and south and east and west distances to the same scale, and if a degree of latitude (which is of course 60 miles) is shown as 10 inches, what distance will represent a degree of longitude? (20)
12. There is curve $y = 2 + 0.15x^2$.

Prove that for any value of x the slope of the curve or $\frac{dy}{dx}$ is $0.3x$. (30)

STAGE 3.

Answer Questions No. 1, No. 2, and No. 3, and five others.

1. The three parts (a), (b), and (c) must all be answered to get full marks:—

(a) Compute by contracted methods to four significant figures only, and without using logarithms,

$$0.03405 \times 0.9123, \text{ and } 34.05 \div 0.09123.$$

(b) Compute, using logarithms,

$$(2.354 \times 1.607)^{0.315}; \text{ and } (32.15)^{-0.152}.$$

(c) Write down the values of

$$\sin 107^\circ; \cos 148^\circ; \tan 250^\circ. \quad (30)$$

2. There are two formulæ used to calculate ϕ :

$$\phi = \log_e \frac{t}{273},$$

which is only approximate;

$$\phi = 1.0565 \log_e \frac{t}{273} + 9 \times 10^{-7} \left(\frac{t^2}{2} - 503t \right) + 0.0902,$$

which is correct.

If $t = \theta + 273$ when $\theta = 53$, find the two answers; what is the percentage error in using the approximate formula? (30)

3. The three parts (a), (b), and (c) must all be answered to get full marks:—

(a) Prove that

$$\sin(A + B) = \sin A \cos B + \cos A \sin B.$$

You may take the simplest case, where $A + B$ is less than a right angle. Illustrate the truth of this arithmetically when $A = 35^\circ$ and $B = 27^\circ$, using your tables.

- (b) Prove that in a triangle whose sides a, b contain between them the angle C the area is

$$\frac{1}{2} ab \sin C.$$

There is a quadrilateral ABCD ; A and C being opposite corners. If AB is 16.23 feet, AC 25.4 feet, AD 12.09 feet ; if the angle BAC is 41° , and the angle CAD is 35° , find the area of the quadrilateral.

- (c) If P is the present value of an annuity A , the first payment being due 1 year from now, the last at the end of the n th year from now, the rate of interest on money being at r per cent. per annum ; then

$$P = 100 \frac{A}{r} \left\{ 1 - \left(1 + \frac{r}{100} \right)^{-n} \right\}$$

If the present value of an annuity of £65 is £627 and r is $3\frac{1}{2}$ per cent. per annum, what is the supposed number of years' duration of the annuity ? (30)

4. Find accurately to three significant figures the value of x which satisfies the equation

$$x^2 - \frac{20}{3} \log_{10} x = 2.359. \quad (30)$$

5. At corresponding high speeds of modern ships of the same class, if v is the speed in knots, D the displacement in tons, P the indicated horse-power, T the time spent in a particular passage, and C the coal consumed,

$$v \propto D^{\frac{1}{2}}, P \propto D^{\frac{3}{2}} v^3, C \propto PT,$$

show how $P, T,$ and C depend upon D alone.

A cross-Atlantic steamer of 10,000 tons at 20 knots crosses in 6 days, its power being 20,000, using 2520 tons of coal ; what must be the displacement, the speed, the power, and the coal for a vessel which makes the passage in 5 days ? (30)

6. Three planes of reference mutually perpendicular meet in the lines OX, OY, OZ . The line OP is 6.2 inches long ; it makes an angle of 62° with OX and 43° with OY . Call the projections of OP upon $OX, OY,$ and OZ by the names $x, y,$ and z and calculate their amounts, taking the positive value in the case of z . What angle does OP make with OZ ?

The plane containing OZ and OP makes an angle ϕ with the plane containing OZ and OX , what is this angle ? (30)

7. In a certain vessel it happens to be true, within certain limits, that

$$V = 1200h^{1.5}$$

where h is the vertical draught in feet and V is the displacement in cubic feet. If A is the area in square feet of a horizontal section on the water-level, express A in terms of h .

If l and b are the length and greatest breadth of the section and if $A = mb$ where n is a constant fraction, show that $V = mlbh$ where m is a constant fraction. (40)

8. The following tests were made upon a condensing-steam-turbine-electric-generator. There are probably some errors of observation, as the measurement of the steam is troublesome :

Output in Kilowatts K	1190	995	745	498	247	0
Weight W lb. of steam consumed per hour .	23,120	20,040	16,630	12,560	8320	4065

Find if there is a simple approximate law connecting K and W .

The electric power goes some distance to drive a factory, and it is found by trial that when Y yards of stuff are being woven per hour

$$K = 48 + 0.45 Y.$$

Express W in terms of Y .

State the meaning of W/Y in words, and find its values when Y is 2000 and when Y is 500. What lesson ought to be drawn from this? (30)

9. A quantity y is a function of x , what do we mean by $\frac{dy}{dx}$? Illustrate your meaning, using a curve. Illustrate your meaning by considering a body which has moved through the space s in the time t . What is $\frac{dy}{dx}$ in the following cases:—

$$y = a + bx + cx^2 + gx^n, \quad y = a \log x, \quad y = ae^{bx}, \quad y = a \sin (bx + c). \quad (40)$$

10. Find the area of the curve

$$y = a + bx^n$$

from the ordinate at $x = 0$ to the ordinate at $x = m$. If n is 2.5, and a is 0, and if the curve passes through the point ($x = 5$, $y = 4$), find b . What is the area of the curve from the ordinate at $x = 0$ to the ordinate $x = 5$? (40)

11. Divide a number a into two parts so that twice the square of one part plus three times the square of the other shall be a minimum.

How do you know that you have found a minimum value? (30)

12. In the atmosphere, if p is pressure and h height above datum level, if

$$w = cp^{1/\gamma}$$

where c and γ are constants, and if

$$\frac{dp}{dh} = -w,$$

find an equation connecting p and h .

What is the above c if $p = \rho R$? Assume $p = p_0$ and $h = h_0$ where $h = 0$. R is a known constant for air.

Find the equation connecting h and t . (50)

13. The following values of y and x being given, tabulate $\frac{\delta y}{\delta x}$ and $y \cdot \delta x$ in each interval, and A or the sum of such terms as $y \cdot \delta x$. Of course A is the approximate area of the curve whose ordinate is y .

y	0	0.1	0.2	0.3	0.4	0.5	0.6	0.7	0.8	0.9
x	0	0.1736	0.3420	0.5000	0.6428	0.7660	0.8660	0.9397	0.9848	1.0000

1905.

STAGE 2.

Answer Questions No. 1, No. 2, No. 3, and five others.

1. The four parts (a), (b), (c), and (d) must all be answered to get full marks.
 (a) Compute by contracted methods to four significant figures only, and without using logarithms,

$$0\cdot01239 \times 5\cdot024 \text{ and } 0\cdot5024 \div 0\cdot01239,$$

- (b) Compute, using logarithms,

$$\sqrt{0\cdot2607}; 26\cdot07^{1\cdot13}; 26\cdot07^{-1\cdot13}$$

- (c) Explain why we subtract logarithms when we wish to divide numbers.
 (d) Write down the values of the sine, cosine, and tangent of 37° . Explain, from the definitions, why $\sin 37^\circ \div \cos 37^\circ = \tan 37^\circ$. Try by division if this is so. (20)

2. The four parts (a), (b), (c), and (d) must all be answered to get full marks.

- (a) Using the tables, find the number of which $0\cdot2$ is the Napierian logarithm.
 If

$$e^x = 1 + x + \frac{x^2}{2} + \frac{x^3}{3} + \text{etc.},$$

calculate e^x when $x = 0\cdot2$, to three decimal places.

After how many terms are more of them useless in this case where we only need three decimal places?

[Note that $\underline{5}$ means $1 \times 2 \times 3 \times 4 \times 5$.]

- (b) Express

$$\frac{0\cdot5x + 14\cdot09}{x^2 - 3\cdot5x - 10\cdot26}$$

as the sum of two simpler fractions.

- (c) The sum of two numbers is $12\cdot54$, and the sum of their squares is $81\cdot56$: find the numbers.
 (d) ABC is a triangle, C being a right angle. The side BC is $12\cdot4$ feet, and the angle A is 65° : find the other sides and angle, using the Tables. (20)

3. x and t are the distance in miles and the time in hours of a train from a railway station. Plot on squared paper. Describe clearly why it is that the slope of the curve shows the speed. Where is the speed greatest, and where is it least?

x	0	0\cdot12	0\cdot5	1\cdot52	2\cdot50	2\cdot92	3\cdot05	3\cdot05	3\cdot17	3\cdot50	3\cdot82
t	0	0\cdot05	0\cdot10	0\cdot15	0\cdot20	0\cdot25	0\cdot30	0\cdot35	0\cdot40	0\cdot45	0\cdot50

(20)

4. Find x in degrees approximately if

$$3 \sin x + 2 \cos x = 3\cdot4.$$

For what value of x is

$$3 \sin x + 2 \cos x$$

a maximum? You may use squared paper.

(28)

5. The net yearly profit P of a railway may be represented by

$$P = bx + cy$$

where x is the gross yearly receipt from passengers, and y from goods; b and c being constant numbers.

When $x = 520000$ and $y = 220000$, P was 330000.

And at a later period

when $x = 902000$ and $y = 700000$, P was 603000.

What will probably be the value of P when $x = 1000000$ and when $y = 800000$? (20)

6. In steamships, $c = D^{\frac{2}{3}}v + I$, where D is the displacement in tons, v the speed in knots, I the indicated horse-power. Now c is not the same for a ship at all speeds, but it is nearly the same for two similar ships at corresponding speeds. Corresponding speeds are as the sixth root of the displacements. Find c from each of the following actual measurements made on a ship of 9764 tons. Tabulate the corresponding speeds for a ship of 12000 tons, and calculate and tabulate the horse-power at each speed.

Speed in knots	10.8	14.33
Indicated horse-power . .	1830	4720

(28)

7. State Simpson's rule. An area is divided into ten equal parts by eleven equidistant parallel lines 0.2 inch apart, the first and last touching the bounding curve; the lengths of these lines or ordinates or breadths are, in inches:—

0, 1.24, 2.37, 4.10, 5.28, 4.76, 4.60, 4.36, 2.45, 1.62, 0.

Find the area in square inches.

(20)

- 8.

$$x = a(\phi - \sin \phi)$$

$$y = a(1 - \sin \phi)$$

Take $a = 10$. Calculate the values of x and y for the following values of ϕ :—

$$0, \frac{\pi}{6}, \frac{\pi}{4}, \frac{\pi}{3}$$

Plot points whose co-ordinates are these values of x and y , on squared paper, and draw a curve. (28)

9. When Q cubic feet of water flows per second through a sharp-edged rectangular notch L feet long, the height of nearly still water above the sill being H feet,

$$Q \propto (L - \frac{1}{2}H)H^{\frac{3}{2}}$$

Now, a bad formula is sometimes used which assumes

$$Q \propto LH^{\frac{3}{2}}$$

Show that for a given L , although a constant may be used to give a correct answer for one value of H , it must give incorrect answers for other values of H . (28)

10. A vessel is shaped like the frustum of a cone; the circular base is 10 inches diameter; the top is 5 inches diameter; the vertical height is 8 inches. What

is the height of the imaginary vertex? If x is the height of the surface of a liquid from the bottom, plot a curve showing for any value of x the area of the horizontal section there.

Find from this the whole volume of the vessel in cubic inches.

[Candidates will notice that if d is the diameter of the circular area, it is only necessary to plot d^2 .] (28)

11. There is a curve

$$y = 1.5 + 0.05x^3$$

Prove that for any value of x , the slope of the curve or $\frac{dy}{dx}$ is $0.1x$. (28)

12. Find accurately to three significant figures one value of x for which

$$5 \log_{10} x + \frac{2}{x} - 2.70 = 0. \quad (28)$$

13. The total cost C of a ship per hour (including interest and depreciation on capital, wages, coal, etc.) is, in pounds,

$$C = 4 + \frac{s^3}{1000}$$

where s is the speed in knots (or nautical miles per hour).

The time in hours spent in a passage of, say, 3000 miles is

$$3000 \div s$$

so that the total cost of the passage is this time multiplied by C . Express this algebraically in terms of s .

Find what this amounts to for various speeds. For what speed is it a minimum? (28)

14. The model of a ship, when being drawn at the following speeds v (in feet per minute), offered the following resistances R (in pounds) to motion:—

V	233	287	347	406	466	525	588	646
R	1.08	1.76	2.93	4.26	6.33	9.52	12.74	15.16

It is to be remembered that there are small errors in such measurements.

If we assume a law like $R = av^n$, find n for the smallest and highest speeds. For what value of v does n seem at its greatest?

[Suggestion, plot $\log R$ and $\log v$ on squared paper.] (28)

STAGE 3.

Answer Questions No. 1, No. 2, No. 3, and five others.

1. The four parts (a), (b), (c), and (d) must all be answered to get full marks:—
(a) Compute by contracted methods to four significant figures only,

$$0.01239 \times 0.5024$$

and $0.1239 \div 50.24$

- (b) Compute, using logarithms,

$$(0.9415 \times 2.304)^{1.72}$$

and $(0.9415 \times 2.304)^{0.172}$.

- (c) Why do we multiply the logarithm of a by b to find the logarithm of a^b ?
 (d) Write down the values of

$$\sin 254^\circ, \cos 124^\circ, \tan 193^\circ, \sin^{-1}(0.2250), \cos^{-1}(-0.8192), \\ \tan^{-1}(-4.0108).$$

Only one value to be given in each of the last three cases. (30)

2. The three parts, (a), (b), and (c) must all be answered to get full marks:—
 (a) A quantity y is a function of x : what do we mean by

$$\frac{dy}{dx}?$$

Illustrate your meaning, using a curve.

Illustrate your meaning by considering the speed of a body which has passed through the space s in the time t .

- (b) Show that if A is the area of a curve from some standard ordinate to the ordinate y corresponding to the co-ordinate x , then

$$y = \frac{dA}{dx}.$$

Hence to find A we merely find that function of x of which y is the differential coefficient.

- (c) If A is the area of the surface of water in a pond when the depth on a given vertical is x , and if v is the volume of water, then

$$A = \frac{dv}{dx}.$$

Prove this.

(30)

3. Define the scalar product and the vector product of two vectors. Give an illustration of each of these from any part of physical science. (30)
 4. The cost C of a ship per hour (including interest and depreciation on capital, wages, coal, etc.) is in pounds

$$C = 4 + \frac{s^3}{1000}$$

where s is its speed in knots relatively to the water.

Going up a river whose current runs at 5 knots, what is the speed which causes least total cost of a passage? (42)

5. In the curve

$$y = a + bx^{\frac{3}{2}}$$

$$\text{If } y = 1.62 \text{ when } x = 1$$

$$\text{and } y = 5.32 \text{ when } x = 4$$

find a and b .

Let this curve rotate about the axis of x .

Find the volume enclosed by the surface of revolution between the two sections at $x = 1$ and $x = 4$. (42)

6. The following values of y and x being given, tabulate $\frac{\delta y}{\delta x}$ and $y \cdot \delta x$ in each interval. If $y \cdot \delta x$ be called δA , tabulate the values of A if A is 0 where $x = 0$.

x	0	0.1	0.2	0.3	0.4	0.5	0.6	0.7	0.8	0.9
y	1.428	1.561	1.691	1.820	1.947	2.071	2.193	2.314	2.431	2.547

(42)

To facilitate tabulation, it will be found convenient to change these rows into columns.

7. What is Simpson's rule? A circle is drawn of 8 inches diameter. The diameter is divided into eight equal parts, and ordinates are drawn at right angles to the diameter. Calculate the lengths of these ordinates, using the tables, and tabulate them. Using Simpson's rule, find the area of the circle.

This answer is in error: what is the percentage error? (42)

8. Find x in degrees if

$$3 \sin x + 2 \cos x = 3.4$$

x is supposed to be an acute angle. How many answers are there?

Find, using the Calculus, for what value of x is

$$3 \sin x + 2 \cos x$$

a maximum?

(42)

9. The following values of ρ and θ being given, find

$$\frac{d\rho}{d\theta} \text{ when } \theta = 115.$$

θ	ρ
100	14.70
105	17.53
110	20.80
115	24.54
120	28.83
125	33.71
130	39.25

(42)

10. If

$$x = a \sin pt + b \cos pt$$

for any value of t where a , b , and p are mere numbers, show that this is the same as

$$x = A \sin (pt + e)$$

if A and e are properly evaluated.

If

$$V = RC + L \frac{dC}{dt}$$

and if

$$C = 100 \sin 600t$$

R being 2 and L being 0.005, find V .

What is the lag of C in degrees behind V ?

(42)

11. A vessel is shaped like the frustum of a cone; the circular base is 10 inches diameter; the top is 5 inches diameter; the vertical height is 8 inches. If x is the height of the surface of a liquid from the bottom, express d the diameter there in terms of x ; express A the horizontal area there in terms of x ; express V the volume of the liquid in cubic inches, in terms of x . (42)

12. Water leaves a circular basin very slowly by a hole at the bottom, every particle describing a spiral which is very nearly circular. Let v be the speed at a point

whose distance from the axis is r , and height above some datum level h . Assume no "rotation" or "spin," that is

$$\frac{1}{r} \left(v + \frac{dv}{dr} \right) = 0$$

and show that this means

$$v = \frac{c}{r}$$

where c is some constant.

Now, at the atmospheric surface

$$\frac{v^2}{2g} + h = C$$

where C is a constant.

Find from this the shape of the surface, that is the law connecting r and h . (42)

13. The model of a ship, when being drawn at the following speeds v (in feet per minute), offered the following resistances R (in pounds) to motion :—

V	179	220	259	301	321	341	361
R	1.78	2.76	4.01	5.69	6.39	8.19	11.39

There are small errors in such measurements.

Assume a law $R \propto v^n$, and describe how n changes. What is its greatest value? Show that when v increases by a small percentage, R increases by n times this percentage. (42)

14. The indicated horse-powers of the engines of similar ships similarly loaded may be taken to be proportional to the 1/6th power of the displacements at corresponding speeds.

Corresponding speeds are as the sixth roots of the displacements. The following measurements were made at different speeds of a vessel of 1000 tons (the United States s. *Manning*). Find the horse-power at the corresponding speeds of a vessel of 5000 tons : state and tabulate these speeds.

Speed in knots	6	11	16
Indicated horse-power	100	486	2181

(42)

1908.

STAGE 2.

You must not attempt more than *eight* questions in all, and of these Nos. 1, 2, and 3 must be three; that is to say, you are allowed to take not more than five questions in addition to Nos. 1, 2, and 3.

1. The four parts (a), (b), (c), and (d) must all be answered to get full marks:—

(a) Without using logarithms, compute by contracted methods to four significant figures

$$9\cdot325 \times 0\cdot02056 \text{ and } 9\cdot325 \div 0\cdot02056.$$

(b) Using logarithms, compute

$$(6\cdot345 \times 0\cdot1075)^{2\cdot5} \div (0\cdot00374 \times 96\cdot37)^3.$$

(c) Extract the cube roots of

$$20760, 207\cdot6, 0\cdot02076, 0\cdot002076.$$

(d) The side of a square is 3 yards 1 foot $9\frac{1}{2}$ inches; find the area of the square in square feet. (22)

2. The four parts (a), (b), (c), and (d) must all be answered to get full marks:—

(a) The difference of x and y is $3\cdot14$; the sum of x^2 and y^2 is 140 ; find x and y .

(b) The inside of a hollow copper sphere is filled with water whose weight is 10 lbs.; what is the inside radius? If the weight of the copper is 30 lbs., what is its thickness? A cubic inch of copper weighs $0\cdot32$ lb.

(c) ABD is a right-angled triangle, B being the right angle. BC is perpendicular to the side AC. The angle A is 56° , BC is 10 inches; find the lengths of AC and CD.

(d) What are the factors of $x^2 - 8\cdot92x + 18\cdot37$? (22)

3. The three parts (a), (b), and (c) must all be answered to get full marks:—

(a) If $y = ax^{1\cdot10} + bx^{2\cdot3}$; if $y = 6\cdot3$ when $x = 1$, and if $y = 133$ when $x = 2$, find a and b .

(b) 20 lbs. of bronze contains 87 per cent. of copper, 13 per cent. of tin. With how much copper must it be melted to obtain a bronze containing 10 per cent. of tin?

(c) If $\frac{x}{y} = e^{\mu\theta}$ and if $\mu = 0\cdot25$, $\theta = 3$, find x/y . It is known that $x - y = 1000$, find x and y . (22)

4. If i means $\sqrt{-1}$, write down the values of i^2, i^3, i^4, i^5, i^6 . Find $\sqrt{17 + 30i}$, \sqrt{i} , $1 \div \sqrt{i}$. Each of the answers is like $a + bi$ where a and b are numbers. (28)

5. x is distance measured along a straight line AB from the point A; the values of y are offsets or distances in links measured at right angles to AB to the border of a field. Find the average breadth from AB to the border of the field between the first and last offset. Notice that the intervals in x are not equal.

x	0	1\cdot50	3\cdot00	5\cdot00	7\cdot50	9\cdot00
y	0\cdot53	0\cdot47	0\cdot40	0\cdot42	0\cdot46	0\cdot52

(26)

6. There is a root of $x^3 - 10x^2 + 40x - 35 = 0$ which lies between 1 and 2; find it, correct to three significant figures. (26)

7. The following numbers give x feet the distance of a sliding piece measured along its path from a certain point to the place where it is at the time t seconds: what (approximately) is its acceleration at all the tabulated times except the first and last? Show in a curve how the acceleration depends upon t .

x	1'000	2'736	4'420	6'000	7'428	8'660	9'660	10'397	10'848	11'000
t	0	0'1	0'2	0'3	0'4	0'5	0'6	0'7	0'8	0'9

(26)

8. The following numbers give v the speed of a train in miles per hour at the time t hours since leaving a railway station. In each interval of time, what is the distance passed over by the train?

v	0	2'4	4'7	7'2	9'6	12'0	14'3
t	0'00	0'4	0'8	0'12	0'16	0'20	0'24

Continued.

v	16'9	18'9	20'7	22'2	23'4	24'3	24'9
t	0'28	0'32	0'36	0'40	0'44	0'48	0'52

At each of the times tabulated, what is x the distance from the station? Tabulate your answers.

(26)

9. Find the area of the parabola $y = a + bx + cx^2$ between the ordinate at $x = a$ and the ordinate at $x = \beta$. If $a = -h$ and $\beta = h$, what is the answer? (22)
10. The parabola $y = a + bx + cx^2$ passes through three points whose co-ordinates are $-h, y_1$; $0, y_2$; h, y_3 . Insert these values, and find a, b , and c in terms of the quantities, y_1, y_2, y_3 and h . (22)
11. The following quantities measured in a laboratory are thought to follow the law $y = ab^{-x}$. Try if this is so, and, if so, find the most probable values of a and b . There are errors of observation.

x	0'1	0'2	0'4	0'6	1'0	1'5	2'0
y	350	316	120	63	12'86	2'57	0'425

(26)

12. The equilibrium position for a certain governor is that a ball should be at a certain distance r from an axis about which it revolves, when the centrifugal force is equal to

$$\frac{200 + 80h}{h}r$$

where $h = \sqrt{2'25 - r^2}$.

Now a certain mathematical investigation becomes too complex if this law is used, whereas it is known that, if the centrifugal force were equal to $br - a$ where a and b are mere numbers, the investigation would be easy. Find if there is approximately such a law within the limits $r = 0'5$ and $r = 0'7$, and what is the maximum error in making such an assumption? (26)

13. One of the three premium systems used in workshops is this :—

If II is the number of hours usually allowed for a job ; the man does it in less time, say, h hours. The usual pay in the shop is p pence per hour ; the premium paid to the man is

$$P = \frac{(II - h)p}{2},$$

and he is also paid hp .

If r pence per hour is the cost of tools and share of total shop charges, the master would have paid $II(p + r)$ for the job. He now pays $P + h(p + r)$.

If II is 20 and p is 10 and r is 4, find the total payment to the man for the job and by the hour, and also the saving to the master on the job ; tabulate your answers for the following values of h : 20, 15, 10. (28)

STAGE 3.

You must not attempt more than eight questions in all, and of these No. 1 must be one ; that is to say, you are allowed to take not more than seven questions in addition to No. 1.

1. The four parts (a), (b), (c), and (d) must all be answered to get full marks.

(a) Without using logarithms, compute by contracted methods so that four significant figures shall be correct, 9.325×0.02056 and $9.325 \div 0.02056$.

(b) Using logarithms, compute

$$(5.603 \times 0.05723)^{-3.457}.$$

(c) Write down the values of

$$\sin 207^\circ, \cos 123^\circ, \tan 325^\circ.$$

(d) Express

$$(2x + 1.38)/(x^2 + 1.38x - 24.6)$$

as the sum of two simpler fractions.

(33)

2. Find, with three significant figures accurate, a root of

$$5x^3 + x \log_{10} x - 4.82 = 0.$$

(33)

3. The following tests were made on a steam electric-generator ; W is weight of steam in pounds used per hour ; K is the output in kilowatts :—

K	3942	3105	1907	910
W	80,400	68,100	50,200	35,100

Find if there is a simple approximate law connecting W and K . State the meaning of W/K in words ; call it w . Express w in terms of K .

(33)

4. By tabulation give, approximately, a table of values of

$$\frac{dy}{dx} \text{ and } \int y \cdot dx$$

if the following values of x and y are given :—

x	0	0.01	0.02	0.03	0.04	0.05	0.06	0.07	0.08	0.09
y	1.2679	1.3640	1.4663	1.5774	1.7002	1.8391	2.0000	2.1918	2.4281	2.7321

(33)

5. If r is the radius of a heavenly body E , l the distance of another heavenly body M , of mass m , from E 's centre. Then $m/(l+r)^2$ and $m/(l-r)^2$ are the accelerations towards M at points on E farthest from and nearest to M . The tide producing actions at these points are their differences from m/l^2 which is the acceleration at E 's centre ; prove that the tide producing effect of M is inversely proportional to the cube of the distance when l is large compared with r . (33)

6. If

$$\frac{M}{c} = \frac{d^2y}{dx^2}, \text{ and } \frac{dM}{dx} = S, \text{ and } \frac{dS}{dx} = \tau\omega.$$

Let $\tau\omega$ be a constant. Find S . Let $S = W$, a constant, when $x = l$. Find M and let $M = 0$ when $x = l$.
 c is a given constant. Find

$$\frac{dy}{dx},$$

and let its value be 0 when $x = 0$. Find y and let its value be 0 when $x = 0$. (33)

7. If

$$\frac{d\rho}{dh} = -\tau\omega$$

and if $\tau\omega \propto \rho$ where c is a constant. Find ρ in terms of h . If $\rho \propto \omega t$, express t in terms of h introducing constant. (33)

8. The total cost C of a ship per hour (including interest, depreciation, wages, coal, etc.) is in pounds

$$C = 3 \cdot 2 + \frac{s^3}{2200}$$

where s is the speed of the ship in knots.

Express the total cost of a passage of 3000 miles in terms of s . What value of s will make this total cost a minimum? At speeds 10 per cent. less and greater than this, compare the total cost with its minimum value. (33)

9. The curve $y = a + bc^x$ passes through the three points $x = 0, y = 26 \cdot 62$; $x = 1, y = 35 \cdot 70$; $x = 2, y = 49 \cdot 81$; find $a, b,$ and c . What is the area of the curve from the ordinate at $x = 0$ to the ordinate at $x = 2$? (42)10. Describe a method of finding whether a given curve follows, approximately, the law $y = a + bx^n$ or $y = b(x + a)^n$ or $y = a + bc^{nx}$. Logarithmic paper must not be used; the work can be done on ordinary drawing paper using T'ec and set squares. (42)11. If $y = a \sin qt$ and $x = b \sin (qt - c)$ where t is time and a, q, b, c are constants; if $q = 2\pi/T$ where T is the periodic time. Find the average value of xy during the time T . (42)12. Q being the rate of flow of water per second over a sharp-edged notch of length l , the height of the surface of nearly still water (some distance back) above the sill being h ; it has been proved that the empirical formula obtained by Dr. Francis is also a rational formula; it is

$$Q \propto (l - \frac{1}{3}h)h^{3/2}.$$

Now an incorrect formula is sometimes used

$$Q = ch^{3/2}.$$

Show that for a given l , although a constant c may be found which will give a correct answer for one value of h , it must give incorrect answers for all other values of h . (33)

13. If i is $\sqrt{-1}$, write down the values of i^2, i^3, i^4, i^5 . Find $\sqrt{17 + 30i}, \sqrt{i}, 1 \div \sqrt{i}$ each in the shape $a + bi$.

If $a + bi$ operating upon $\sin qt$ (where t is the variable and q is a constant) gives $a \sin qt + b \cos qt$, find three answers, the effects of operating with $\sqrt{17 + 30i}, \sqrt{i},$ and $1 \div \sqrt{i}$ upon $\sin qt$. (33)

14. Get instructions from Ques. 13.

The voltage applied at the sending end of a long telephone line being $v_0 \sin qt$, the current entering the line is

$$v_0 \sqrt{\frac{s + ikq}{r + ilq}} \sin qt$$

where, per unit length of cable, r is resistance, l is inductance, s is leakage, and k is permittance, or capacity.

If $r = 6$ ohms, $l = 0 \cdot 003$ Henries, $k = 5 \times 10^{-8}$ farads, $s = 3 \times 10^{-6}$ Mho, and if $q = 6000$, find the current. (42)

NOTE.—There is a quicker method of working than what is indicated in Ques. 13, using DeMoivre. You may use it if you please.

ANSWERS TO THE EXAMPLES

EXAMPLES.—I. (Page 2.)

- | | |
|---|---|
| 1. 2, 3, 2, 3, 12, 31, 3. | 2. 8, 512, 27, 81, 10,000,000. |
| 3. $\frac{1}{16}$, $\frac{1}{8}$, $\frac{1}{25}$, $\frac{1}{10}$, $\frac{1}{25}$, $\frac{1}{17}$. | 4. 0·1, 0·3162, 1, 3·162, 10, 31·62, 100. |

EXAMPLES.—II. (Page 2.)

- | | | | | | |
|--------------------|--------------------|--------------------|----------|-----------|--------|
| 1. $\frac{1}{6}$. | 2. $\frac{1}{2}$. | 3. $\frac{1}{6}$. | 4. 2·25. | 5. 3·5. | 6. -2. |
| 7. -1. | 8. 0. | 9. 0·5. | 10. 1·5. | 11. -0·5. | |

EXAMPLES.—III. (Page 5.)

1. 2·3010; 1·3010; 0·3010; $\bar{4}$ ·3010.
2. 3·8942; $\bar{2}$ ·8942; 1·8942; 0·8942; $\bar{1}$ ·8942; $\bar{2}$ ·8942; $\bar{3}$ ·8942.
3. 6·3336; $\bar{4}$ ·3336; 7·3336.
4. 0·4972; 1·4720; 1·6695; 0·8956; 1·0538; 1·0689; $\bar{2}$ ·1954; 3·3755.
5. 1433; 200; 30; 3·657; 0·1887; 0·002316; 0·05820.
6. 0·8372; 1·2726; 1·5304; 2·1815.

EXAMPLES.—IV. (Page 7.)

- | | | | |
|--------------|---------------|--------------------------------|--------------|
| 1. 918·1. | 2. 2·090. | 3. 40430. | 4. 34·18. |
| 5. 581·5. | 6. 269100. | 7. 0·003856. | 8. 410·7. |
| 9. 8·076. | 10. 0·002468. | 11. 11880. | 12. 601300. |
| 13. 15·84. | 14. 0·5944. | 15. 15·35. | 16. 3·307. |
| 17. 0·3307. | 18. 0·4872. | 19. 4·658. | 20. 1·473. |
| 21. 13·59. | 22. 6·310. | 23. 2·929. | 24. 1·359. |
| 25. 57530. | 26. 0·01902. | 27. 1·017. | 28. 6056. |
| 29. 54·8. | 30. 1·005. | 31. 1·838 × 10 ¹⁸ . | 32. 0·01645. |
| 33. 10810. | 34. 1135. | 35. 0·1370. | 36. 0·7945. |
| 37. 0·01176. | 38. 0·5338. | 39. 1·079. | 40. 13·75. |
| 41. 1·035. | 42. 0·8228. | 43. 0·2133. | 44. 0·9833. |
| 45. 16·88. | 46. 0·7025. | 47. 0·5504. | 48. 31780. |
| 49. 3220. | 50. 4·000. | 51. 837·1. | 52. 3542. |
| 53. 37390. | | | |

EXAMPLES.—V. (Page 10.)

- | | |
|---|---|
| 1. 2·65; 3·58; -4·7; 5·24; -14·65; 23·56. | 4. 74·5°; 166·2°. |
| 5. 7·872 ft. | 6. 81·7 ft. per sec. |
| 7. 18·5. | 8. 0·000072; 1522. |
| 9. 57·6 ft. per sec. | 10. -1170°; -97·5° and -5682°; -473·5°. |
| 11. 308·5°; 235°; 232·5°; 227·5°. | |

Answers to the Examples

EXAMPLES.—VI. (Page 11.)

3. ($3\cdot606, 56\cdot3^\circ$); ($5\cdot38, 21\cdot8^\circ$); ($3\cdot16, 18\cdot4^\circ$); ($3\cdot606, 113\cdot7^\circ$); ($5\cdot83, 211^\circ$); ($5, 143\cdot1^\circ$).
 4. ($0\cdot966, 0\cdot259$); ($1\cdot732, 1$); ($0\cdot877, 1\cdot80$); ($-0\cdot684, 1\cdot88$); ($-1\cdot53, -1\cdot29$); ($1, -1\cdot732$).

EXAMPLES.—VII. (Page 12.)

2. See tables, p. 438. 3. $23^\circ, 62\cdot9^\circ, 53\cdot1^\circ, 31\cdot8^\circ, 21\cdot8^\circ, 35^\circ, 60^\circ, 78\cdot7^\circ$.

EXAMPLES.—VIII. (Page 14.)

- | | |
|--|--|
| 2. $0\cdot643$; $-0\cdot766$; $-0\cdot839$. | 3. $-0\cdot643$; $-0\cdot766$; $0\cdot839$. |
| 4. $-0\cdot766$; $0\cdot643$; $-1\cdot192$. | 5. $0\cdot8$; $0\cdot75$ |
| 6. $-0\cdot8$; $-0\cdot75$. | 7. $-0\cdot8$; $0\cdot75$. |
| | 8. $0\cdot8$; $-0\cdot75$. |

EXAMPLES.—IX. (Page 18.)

1. 8. The numerical values are given in the tables, p. 438; the signs may be verified from the figures.
 9. $0\cdot4493$; $0\cdot8934$; $0\cdot5029$. 10. $0\cdot7278$; $-0\cdot6858$; $-1\cdot0612$.
 11. $-0\cdot6613$; $-0\cdot7501$; $0\cdot8816$. 12. -7524 ; $0\cdot6587$; $-1\cdot1423$.
 13. $0\cdot8554$; $-0\cdot5388$; $-0\cdot9903$. 14. $12\cdot4^\circ$; $59\cdot7^\circ$; $67\cdot3^\circ$; $52\cdot4^\circ$.
 15. $-0\cdot5774$; $0\cdot574$; $0\cdot282$; $-0\cdot961$; -1 ; $0\cdot966$.
 16. $-0\cdot4162$; $0\cdot1357$. 17. $-0\cdot1392$.
 18. $-0\cdot9191$. 19. $0\cdot909$; $-0\cdot416$; $-2\cdot184$; $0\cdot141$; $-0\cdot990$; $-0\cdot142$.

EXAMPLES.—X. (Page 23.)

- | | | |
|--|---|---|
| 6. $0\cdot954$; $0\cdot314$. | 7. $0\cdot968$; $3\cdot871$. | 8. $0\cdot894$; $0\cdot447$. |
| 9. $0\cdot8454$; $0\cdot6318$. | 10. $0\cdot8802$; $1\cdot855$ | 11. $0\cdot9920$; $0\cdot1256$; $7\cdot897$. |
| 12. $0\cdot6$; $0\cdot8$. | 13. $0\cdot937$; $0\cdot374$. | 14. $\frac{1}{3}$; $\frac{1}{2}$. |
| 15. $\frac{2}{3}$; $\frac{4}{5}$. | 16. $\frac{3}{5}$; $\frac{1}{3}$; $\frac{2}{5}$. | 17. $\frac{8}{11}$; $\frac{6}{11}$. |
| 18. $\frac{2}{3}$; $\frac{7}{5}$. | 19. $\frac{4}{11}$; $\frac{9}{11}$. | 20. $\frac{y}{\sqrt{x^2+y^2}}$; $\frac{x}{\sqrt{x^2+y^2}}$. |
| 21. $\sin \theta = \frac{\sqrt{x^2+y^2}}{\sqrt{x^2+y^2+z^2}}$; $\tan \theta = \frac{\sqrt{x^2+y^2}}{z}$. | | |

EXAMPLES.—XI. (Page 26.)

- | | |
|--|---|
| 1. $b = 2\cdot72$; $c = 3\cdot21$; $B = 58^\circ$. | 2. $B = 34^\circ$; $a = 5\cdot635$; $c = 6\cdot79$. |
| 3. $A = 41^\circ$; $a = 1\cdot77$; $b = 2\cdot04$. | 4. $c = 4\cdot34$; $A = 38\cdot4^\circ$; $B = 51\cdot6^\circ$. |
| 5. $a = 158$; $A = 70\cdot8^\circ$; $B = 19\cdot2^\circ$. | 6. $b = 92\cdot6$; $A = 19\cdot05^\circ$; $B = 70\cdot95^\circ$. |

EXAMPLES.—XII. (Page 30.)

- | | |
|---|---|
| 1. $a = 3\cdot161$; $b = 3\cdot863$; $C = 117^\circ$. | 2. $C = 49^\circ$; $a = 3\cdot03$; $c = 2\cdot70^\circ$. |
| 3. $a = 7736$ yds.; $c = 7073$ yds.; $C = 62^\circ$. | 4. $C = 53^\circ$; $b = 3\cdot123$; $c = 3\cdot727$. |
| 5. $C = 37\cdot92^\circ$. | 6. $A = 110\cdot2^\circ$; $C = 30\cdot75^\circ$. |
| 7. $B = 24\cdot25^\circ$ or $155\cdot75^\circ$; $C = 132\cdot75^\circ$ or $1\cdot25^\circ$. | |
| 8. $C = 126\cdot94^\circ$ or $1\cdot06^\circ$; $B = 27\cdot06^\circ$ or $152\cdot94^\circ$. | |

9. $B = 56.15^\circ$ or 123.85° ; $C = 84.85^\circ$ or 17.15° .
 10. $B = 16.1^\circ$; $C = 142.9^\circ$; $c = 5.84$.
 11. $A = 38.6^\circ$ or 141.4° ; $C = 110.4^\circ$ or 7.6° ; $c = 4.82$ or 0.672 .
 12. $b = 146.7$ ft.; $c = 283.7$ ft.
 13. $B = 44.95^\circ$ or 135.05° ; $C = 103.05^\circ$ or 12.95° ; $c = 5.514$ or 1.27 .
 14. $C = 56.7^\circ$ or 123.3° ; $B = 82.3^\circ$ or 15.7° ; $b = 3.869$ or 1.054 .
 15. $B = 31^\circ$; $c = 237.2$ yds.; $a = 423.7$ yds.
 16. $A = 38.2^\circ$; $C = 86.8^\circ$; $c = 57.5$.
 17. $b = 3.70$; $A = 40.5^\circ$.
 18. $B = 59.1^\circ$ or 120.9° ; $C = 88.9^\circ$ or 27.1° .
 19. $A = 54^\circ$; $B = 85^\circ$.

EXAMPLES.—XIII. (Page 32.)

1. $c = 3.65$.
 2. $c = 3.421$; $A = 35.95^\circ$; $B = 102.05^\circ$.
 3. $A = 5^\circ$; $c = 5.72$.
 4. $c = 2.903$.
 5. $c = 3.877$.
 6. $c = 4.18$.
 7. $b = 5.307$.
 8. $a = 300.9$.
 9. $a = 2.84$.
 10. $c = 5.265$.
 11. $a = 264$ yds.
 12. $a = 583$ yds.
 13. $B = 49.4^\circ$; $A = 71.6^\circ$.
 14. $C = 105.2^\circ$; $A = 44.9^\circ$; $B = 29.9^\circ$.
 15. $A = 33.6^\circ$.
 16. $c = 67$ yds.
 17. $A = 29^\circ$; $B = 46.6^\circ$; $C = 104.4^\circ$.
 18. $A = 81.8^\circ$; $B = 54.2^\circ$; $C = 44^\circ$.
 19. $c = 38.75$ ft.

EXAMPLES.—XIV. (Page 34.)

1. 7074000 sq. ft.
 2. 5078000 sq. ft.
 3. 92.51 sq. ft.
 4. 91050 sq. yds.
 5. 87340 sq. ft.
 6. 1504 sq. yds.
 7. 17.4.
 8. 4.718.
 9. $B = 104.5$; area = 2.783 sq. ft.
 10. $C = 113.6^\circ$; area = 13.28.
 11. $C = 51.3^\circ$; $A = 18.2^\circ$; $B = 110.5^\circ$; area = 1.170.
 12. $A = 44.4^\circ$; area = 14.7.

EXAMPLES.—XV. (Page 36.)

1. 34.4 ft.
 2. 1390 ft.
 3. 335 ft.
 4. 30 ft.
 5. 58.6 ft.
 6. 89.6 ft.
 7. 381.7 ft.
 8. 5863 ft.
 9. 3962 yds.; 4023 yds.
 10. 27.6°.

EXAMPLES.—XVI. (Page 38.)

1. 1680 yds.; 1248 yds.; 175.8 ft.
 2. 349.9 ft.
 3. 54.73 ft.
 4. 1944 ft.
 5. 3753 ft.
 6. 5189 ft.
 7. 5599 ft.
 8. 1321 ft.
 9. 144 yds.; 194.2 yds.
 10. 122.5 miles; 113 miles.
 11. 141.4 yds.
 12. 3.005 miles.

EXAMPLES.—XVII. (Page 43.)

1. 0.75.
 2. 0.981.
 3. $\frac{2}{3} \frac{1}{11} \frac{1}{11}$; $-\frac{1}{3} \frac{1}{11} \frac{1}{11}$.
 4. $\frac{1}{11} \frac{1}{11}$.
 5. $\frac{1}{11} \frac{1}{11}$.
 6. 0.673; 0.909.
 7. $\frac{1}{11} \frac{1}{11}$.
 8. $3.6 \sin(2t + 0.983)$.
 9. $3.6 \sin(2t - 0.588)$.
 10. $53 \sin(2\pi t + 0.557)$.
 11. $37 \left(\frac{2\pi t}{p} - 0.330 \right)$.
 12. 17°.
 13. 0.25.

Answers to the Examples

EXAMPLES.—XVIII. (Page 44.)

3. $-0\cdot679$. 4. $0\cdot574$. 5. $\frac{2}{3}$; $\frac{7}{8}$; $\frac{2}{3}$.
 6. $\frac{840}{1081} = 0\cdot777$. 7. $\frac{1}{15} = 0\cdot533$. 8. $-0\cdot446$; $0\cdot895$.
 10. $0\cdot994$; $0\cdot111$; $8\cdot944$. 11. $0\cdot960$; $-0\cdot279$.
 12. $2b \cos^2(2\pi nt) + a \cos 2\pi nt - b$. 14. $0\cdot8$.
 15. $0\cdot4$. 16. $0\cdot274$; $0\cdot962$.

EXAMPLES.—XX. (Page 47.)

11. $-\frac{ab}{2} \cos\left(2ft + \pi\right)$. 12. $\frac{1}{2}(\cos g - \cos(4\pi nt + g))$.

EXAMPLES.—XXI. (Page 51.)

1. 81 lbs. 2. 7·3 ins. 3. 3·34 ohms.
 4. 1·225 dynes. 5. 22050; 0·417. 6. 17.
 7. 2·43 lbs. 8. H.P. = 0·0091. $\sqrt{\frac{T^3}{W}}$. 9. 1·04 ins.
 10. 14×10^6 . 11. 356 cub. ft. 12. 2·5 ins. of water.
 13. 0·9982. 14. 6·756. 15. 1·712.
 16. 1·946. 17. $-0\cdot274$. 18. 1·060.
 19. $-0\cdot097$; 2·57. 20. 373·1 lbs.; 5553 lbs. 21. 2·54.
 22. 3·47. 23. 55·158. 24. 3215; 2232; 1723.
 25. 45·7; 28·9; 20·9. 26. 19·72; 4·356; 1·55.
 27. 96·5; 93·7; 70·0; 38·5; 20·0. 28. 97; 94·3; 72; 41·4; 22·5.
 29. 2·16; 2; 1·85; 1·66. 30. 96·4; 93·4; 68·7; 36·9; 18·6.
 31. 199·2. 32. 31·13. 33. 8847·3.
 34. 8·3. 35. 0·00000750. 36. 0·233.
 37. 0; 0·104; 0·199; 0·285. 38. 1·644.
 39. 0·2345. 40. 0·0208.

EXAMPLES.—XXII. (Page 55.)

1. £37 14s. 2. £1722. 3. £21 8s.
 4. 1·1 per cent. 5. 16·48 yrs. 6. 1·6 per cent.
 7. 2 yrs. (1·96). 8. A loss, £5294. 9. $A = P\left(1 + \frac{rn}{100}\right)$.
 10. $\frac{100r}{n}$ per cent. 11. $D = \frac{nrA}{1200 + nr}$. 12. $x = \frac{n^2 r^2 A}{(1200 + nr)1200}$.
 13. £772. 14. £2090. 15. £93·1. 16. £1096. 17. £549.

EXAMPLES.—XXIII. (Page 58.)

1. 136 yds. 2. 6484 sq. yds. 3. 4·4 sq. ft.
 4. 5·37 sq. ft. 5. 20 cub. ins. 6. 194 cub. ft.
 7. 5·17 ins. 8. 50266 sq. ft. 9. 772 cu. ins.
 10. 0·029 in. 11. Cross-section = 0·0353 sq. in.; diameter = 0·212 in.
 12. 4·936 lbs. 13. $\frac{1}{8}$ in. 14. 0·19 in.
 15. 1588 lbs. 16. 0·26 lb. 17. 555 lbs.
 18. 4·35 ins. 19. 1224. 20. 3010 lbs.

21. 2010. 22. 245 lbs. ; 3 ins. 23. 1'59 mm.
 24. 1'004 in. ; 2'56 lbs. 25. 198'1 lbs. 26. 8'8 ins.
 27. 10'1 ins. ; 6'67 ins. 28. 207'3 sq. ins. 29. 76'33.
 30. 3'67 ins. 31. 62400 cub. ft.

EXAMPLES.—XXIV. (Page 61.)

3. 0'9998. 4. 0'994. 5. 1'006. 6. 0'988. 7. 0'9991.
 8. 0'9933. 9. 1'01. 10. 10'099. 11. 15'937. 12. 27'019.
 13. 14'967. 14. 6'0092. 15. 8'9959. 16. 0'0102. 17. 0'00198.
 18. 0'9911. 19. 0'3 per cent. deficit. 20. 0'35 per cent.
 21. 43 secs. 22. 15'7 cub. ins. 23. 2 per cent.
 24. (a) the ratio is diminished by 15 per cent. ; (b) it is diminished by 25 per cent. nearly.
 25. 4 per cent. ; 1 per cent. ; -1 per cent. 26. 2 per cent. deficit.

EXAMPLES.—XXV. (Page 64.)

1. $1'356 \times 10^7$. 2. 445000 dynes. 3. 5240. 4. 981 cm. per sec. per sec.

EXAMPLES.—XXVI. (Page 66.)

1. 1 ; 0'5. 2. - 3'12 ; - 0'21. 3. 1'566 ; - 0'766.
 4. 1 ; - 2'3. 5. - 1'15 ; 0'65. 6. $0'3 \pm 0'843i$.
 7. $\frac{1 \pm 6'86i}{6}$. 8. $\frac{-13 \pm 29'03i}{46}$. 9. $\frac{2'5 \pm 4'945i}{2'6}$.
 10. $-0'55 \times 10^3$; $-0'29 \times 10^4$. 11. $-0'4 \times 10^4$ equal. 12. $\frac{-1'9 \pm 0'62i}{5} 10^5$.

EXAMPLES.—XXVII. (Page 67.)

1. - 2 ; - 1. 2. - 3 ; 1. 3. - 1 ; - 1. 4. - 3 ; - 2.
 5. 2 ; - 5. 6. 6 ; $\frac{1}{3}$. 7. 2'5 ; - 3. 8. 2 ; 0'4.
 9. $\frac{6}{11}$; - $\frac{7}{11}$. 10. 2 ; 4. 11. $\pm iq$. 12. $\pm m$; $\pm im$
 13. The roots are real and unequal, equal or imaginary according as L is less than equal to or greater than $\frac{1}{4}R^2K$.
 14. (a) $-1\frac{1}{3}10^4$, $-8\frac{2}{3}10^4$; (b) $-(1 \pm i)10^4$; (c) -2×10^4 .
 15. $\pm \frac{i}{\sqrt{mh}}$. 16. $K^2 = \frac{4W}{gh}$. 17. $-1'29 \pm 15'75i$.

EXAMPLES.—XXVIII. (Page 69.)

1. 1 ; 2 ; - 4. 2. 3 ; 5 ; - 1. 3. 1 ; $\frac{-1 \pm 2'65i}{2}$.
 4. - 2 ; $\frac{-3 \pm 4'8i}{4}$. 5. 1 ; - 1 ; 2 ; 3.

EXAMPLES.—XXIX. (Page 69.)

1. 2'255. 2. 1'77. 3. 0'750. 4. 0'0702.
 5. 47'5. 6. 2'5. 7. 18'2. 8. c ; 0'527.

EXAMPLES.—XXX. (Page 72.)

1. 3·6; 3·8. 2. $m = 1·2$; $c = 2·2$. 3. $-19·5$. 4. $y = 9 - 3x$.
 5. $x = 8$; $y = 5$; $z = 11$.
 6. $x = -1·848$, or $0·648$; $y = -3·544$, or $3·944$.
 7. $x = 2·396$, or $0·046$; $y = 6·188$, or $-0·862$.
 8. $c = \frac{a}{m}$. 9. 2; 5. 10. 5·44 11. 82·4
 12. $a = 21$; $b = 36$; $c = 1·2$. 13. $y = 4·2x^{1·8}$.
 14. $y = 2·8x^{-1·4}$. 15. 42·66.
 16. $P = 125 + 1·3V^2$. 17. $n = 1·25$; $C = 7550$.
 18. $n = 1·37$; $C = 550$. 19. 0·55. 20. $-1·483$.
 21. $b = 36$; $a = 3·102 \times 10^{-10}$. 22. 23·62.
 23. $t^{\gamma} p^{1-\gamma} = c_1^{\gamma} c_2^{1-\gamma}$. 24. 262·5.
 25. $\phi = K \log_e \frac{t}{t_0} - R \log_e \frac{p}{p_0}$; $\phi = k \log_e \frac{t}{t_0} + R \log_e \frac{v}{v_0}$.
 26. $a = 3·8$; $b = 0·15$. 27. $a = 56·5$; $b = -0·23$.
 28. 0·308. 29. $a = 0·0455$; $b = -0·01856$. 30. $9·03 \times 10^8$.
 31. $A = 6·101$; $B = 1520$; $C = 123000$. 32. 0·0947.
 33. 0·08265. 34. $a = 1·552$; $b = 0·0105$; $c = 0·0319$.

EXAMPLES.—XXXI. (Page 75.)

1. $\frac{12}{x^2 - 4}$. 2. $\frac{10x^2 - 22x - 6}{(x^2 - 9)(x - 2)}$. 3. $\frac{2x^2 + 21x + 13}{(x+1)(x+2)(x-5)}$.
 4. $\frac{-17x^2 + 25x + 348}{(2x+9)(3x-1)(x+7)}$. 5. $\frac{5x^2 + 13x + 16}{(x^2 + 2x + 5)(x-3)}$.
 6. $\frac{-x^2 + 15x - 41}{(x^2 - 4x + 9)(x-2)}$. 7. $\frac{5x^2 - 13x + 10}{(x-2)^2(x-1)}$.
 8. $\frac{13x^2 + 74x + 132}{(x+5)^2(x+2)}$. 9. $\frac{8x^2 + 22x + 19}{(x+2)^2(x+1)}$.
 10. $\frac{2x-5}{(x+2)(2x-1)}$. 11. $\frac{1}{(x-1)(x+2)(x-5)}$.

EXAMPLES.—XXXII. (Page 77.)

1. $\frac{1}{x-2} - \frac{1}{x+2}$. 2. $\frac{1}{x+3} - \frac{1}{x+5}$. 3. $\frac{1}{x+1} + \frac{2}{x+6}$.
 4. $\frac{1}{x+3} + \frac{1}{x+2}$. 5. $\frac{5}{9(x-5)} + \frac{4}{9(x+4)}$. 6. $\frac{1}{x-1} + \frac{1}{x+2} - \frac{2}{x+3}$.
 7. $\frac{1}{x-3} + \frac{1}{x+2} - \frac{4}{2x+1}$. 8. $\frac{1}{x+1} + \frac{1}{(x+1)^2} + \frac{2}{x-2}$.
 9. $\frac{4}{15(x-2)} + \frac{7}{5(x+3)} - \frac{2}{3(x+1)}$. 10. $\frac{1}{9(x-4)} + \frac{8}{45(2x+1)} - \frac{1}{5(x+3)}$.
 11. $\frac{5}{6(x-1)} + \frac{1}{2(x+1)} - \frac{4}{3(x+2)}$.
 12. $\frac{1}{70(x-4)} + \frac{1}{30(x+1)} - \frac{1}{30(x-2)} - \frac{1}{7(x+3)}$.
 13. $\frac{2}{7(x-4)} - \frac{1}{6(x-3)} - \frac{5}{42(x+3)}$. 14. $\frac{9}{5(x+4)} - \frac{1}{x+3} + \frac{1}{5(x-1)}$.

15. $\frac{1}{49(x-3)} + \frac{1}{49(x+4)} - \frac{4}{49(2x+1)}$
 16. $\frac{2}{(x-1)} + \frac{3}{(x-1)^2} + \frac{1}{(x-4)} + \frac{4}{x+3}$
 17. $\frac{2x+3}{x^2+3x+4} + \frac{3}{2x-1}$
 18. $\frac{3}{x-2} - \frac{3x+1}{x^2+x+3}$
 19. $\frac{11x-23}{64(x^2+x+2)} - \frac{11}{64(x-2)} + \frac{7}{8(x-2)^2}$
 20. $\frac{1}{b-a} \left(\frac{1}{\theta+a} - \frac{1}{\theta+b} \right)$

EXAMPLES.—XXXIII. (Page 81.)

- | | |
|-----------------------------------|------------------------------------|
| 1. 0'4609; 0'4664; 27'47°; 27'2°. | 2. 0'9483; 0'9473; 71'8°; 71'48°. |
| 3. 0'5358; 0'5314; 57'75°; 57'2°. | 4. 0'6644; 0'6556; 33'11°; 33'43°. |
| 5. 0'00785; 0'0253; 0'04275. | 6. 0'5978; 0'6056; 34'38°. |
| 7. 68'47°; 137'5°. | 8. 1'110162. |
| 9. 1'030810. | 10. -0'7146; 135'78°. |

EXAMPLES.—XXXIV. (Page 82.)

- | | | |
|--------------------|---------------------------|--------------------|
| 1. 6214'2; 6290'1. | 2. 0'0024713; 0'00246214. | 3. 5'076; 14'907. |
| 4. 0'9871; 0'8873. | 5. 82'9; 188'3. | 6. 1'8420; 2'0108. |
| 7. 2'7386; 2'8723. | | |

EXAMPLES.—XXXV. (Page 85.)

- | | |
|---|---|
| 1. £118'87; £180'87. | 2. 135 yds.; 275 yds. |
| 3. 7400 lbs. steam per hour; 540 I.H.P. | 4. 21364; 20895; 19871. |
| 5. 32'8; 40. | 6. 4'5 ins.; 2450 lbs. |
| 7. 2880; 121'2°. | 8. 6'17 cub.ft.; 5'45 cub. ft.; 4'83 cub. ft. |
| 9. 186; 198. | 10. 4 - 3; 4 - 25. |
| 11. 49'77; 44'26; 42'58; 23'35. | 12. 665000; 870. |
| 13. 117; 161; 213. | 14. £101, about. |
| 15. 1450. | 16. 29s. 10d. |

EXAMPLES.—XXXVI. (Page 90.)

- | | | |
|--|-------------------------|-------------------------|
| 9. $y = \frac{3}{2}x + 7\frac{1}{2}$. | 10. $y = 2x - 7$. | 11. $y = -5x + 3$. |
| 12. $3y + 4x + 1 = 0$. | 13. $y = -0.6x + 2.2$. | 14. $5y + 8x + 1 = 0$. |
| 15. $11y + x - 39 = 0$. | 16. $y = -3x + 8$. | 17. $y = 0.1x - 2.3$. |

EXAMPLES.—XXXIX. (Page 102.)

- | | |
|------------------------------------|---|
| 5. 2'60; 3'45. | 14. £109 5s. 5d.; £122 19s. 9½d.; 5½ years. |
| 16. 8'2 ft. per second. | 18. 0'71. |
| 19. 86 amps; 126 amps. | 20. 0'14. |
| 21. 20'1 ins.; 12'2 ins.; 110 lbs. | |

EXAMPLES.—XLI. (Page 118.)

- | | |
|--|--|
| 6. $s = \sin(1'2043t)$; values of t are taken as abscissæ. | |
| 7. $s = \sin(-1'2043t)$. | |
| 8. $s = 6 \sin(0'5236t + 0'7854)$ ins.; $s = 6 \sin(0'7854 - 0'5236t)$. | |
| 9. $y = 9(1'0472x + 0'2269)$. | 10. $s = 1'8 \cos(240\pi t - 0'733)$. |

EXAMPLES.—XLV. (Page 121.)

14. $y = 3 \sin(4\pi t + 0.7854) + 2 \sin(4\pi t + 2.356)$.

EXAMPLES.—XLVI. (Page 126.)

- | | | | |
|---------------|----------------|------------------------|-------------|
| 1. 1.3; -2.1. | 2. 0.31; 0.52. | 3. 2. | 4. 1; 2; 3. |
| 5. -1.3. | 6. 3; -2; -1. | 7. 1.2; 4.1. | 8. 0.649. |
| 9. -0.763. | 10. 2.506. | 11. 2.1. | 12. 1.31. |
| 13. 0.384. | 14. 0.13. | 15. 0.31; 0.86; 1.429. | |
| 16. 4.49. | 17. 363.7. | | |

EXAMPLES.—XLVII. (Page 128.)

- | | | |
|--|---------------------------------------|-------------------------------------|
| 1. $y = 2x - 3$. | 2. $y = 1.4x + 7.6$. | 3. $y = -0.08x + 11.5$. |
| 4. $I = 606.5 - 0.695\theta$. | 5. $II = 606.5 + 0.305\theta$. | 6. $V = 100 + 0.367t$. |
| 7. $l = 10 + 0.00534W$. | 8. $V = 100 + 0.018\theta$. | 9. $s = 1.00664 - 0.000557\theta$. |
| 10. $S = 0.033266 - 0.000092t$. | | 11. $S = 73 + 0.73t$. |
| 12. $S = 54.2 + 0.5t$. | 13. $\Lambda = 295 + 11.8n$. | £377.6. |
| 14. $P = 2.7511 + 10.04$; $C = \frac{10.04}{11} + 2.75$. | | 15. £95; $P = 3.32t + 2.23$. |
| 16. $v = 0.844u$. | 17. $W = 60 + 23.75I$. | 18. $W = 43 + 16I$. |
| 19. $W = 62 + 13I$. | 20. 133 amps.; $A = 0.0423P + 48.5$. | |
| 21. Torque = $7.3 \times$ current. | | |
| 22. $P = 0.12W + 2.4$; efficiency = $\frac{W}{3.3W + 65}$. | | |

EXAMPLES.—XLVIII. (Page 135.)

- | | | |
|---------------------------------------|--|---------------------------------|
| 1. $y = 21 + 0.2x^2$. | 2. $y = 103 + 5x^2$. | 3. $y = 20 - 3xy$. |
| 4. $xy = 1.5x - 2.2y$. | 5. $y = 47 - 0.07x^2$. | 6. $y = 5.6 + 0.3xy$. |
| 7. $y = xy - 1.5$. | 8. $xy = 12.6x - 15.9y$. | 9. $xy = 0.67x + 1.33y$. |
| 10. $y = 6.32 + 0.326x^2$. | 11. $y = 31 + 0.0065xy$. | 12. H.P. = $1.26V^2 + 125$. |
| 13. $V = \frac{2}{\mu}$. | 14. $R = 6 + 0.009V^2$. | 15. $P = 2.8S^2 + 3.1$. |
| 16. $P = 5.1S^2 + 2.2$. | 17. $x = 0.7 + \frac{420}{P}$. | 18. $V = 45 + \frac{43}{A}$. |
| 19. $V = 47.5 + \frac{54}{A}$. | 20. $V = 42 + \frac{33}{A}$. | 21. $D = \frac{144}{134 + r}$. |
| 22. $D = \frac{144}{144 - r}$; 1.26. | 23. $v = \frac{0.0157}{1 + 0.035\theta}$. | 24. $E = 2.86t + 0.001t^2$. |

EXAMPLES.—XLIX. (Page 141.)

- | | |
|--|--|
| 1. $y = 5 + 0.6x - 0.1x^2$. | 2. $\theta = 132 + 0.875x + 0.01125x^2$. |
| 3. $E = 21483 - 0.295t - 0.02415t^2$. | 4. $\gamma = 10^{-9}(182,000 + 0.175t + 0.035t^2)$. |

EXAMPLES.—L. (Page 143.)

- | | | |
|------------------------|---------------------|----------------------|
| 1. $y = 2x + 0.05$. | 2. $y = 3.2x + 9$. | 3. $y = 2x + 18.3$. |
| 4. $y = 4.3x + 12.7$. | | |

EXAMPLES.—LI. (Page 148.)

- | | | |
|-------------------------------|---------------------------------|---------------------------------------|
| 1. $y = x^{2.5}$. | 2. $y = x^{-1.02}$. | 3. $y = 0.0447x^{1.35}$. |
| 4. $y = 2.5x^3$. | 5. $y = 1.3x^4$. | 6. $y = 2.5x^{3.3} \times 10^{-11}$. |
| 7. $y = 300x^{-3}$. | 8. $y = x^{-1.37}$. | 9. $y = 1.05x^{-0.634}$. |
| 10. $n = 1.13$. | 11. $n = 0.9$. | 12. $n = 1.3$. |
| 13. $n = 1.37$. | 14. $n = 1.41$. | 15. $t = 237\theta^{0.29}$. |
| 16. $F = \frac{6.4}{d^2}$. | 17. $D = 0.98H^{\frac{1}{3}}$. | 18. $D = 14.8N^{-\frac{1}{3}}$. |
| 19. $V = 1400k^{1.5}$. | 20. $I = 4.171\theta^{0.07}$. | 21. $W = 2350d^{3.63}$. |
| 22. $P = 0.57\pi^{0.25}$. | 23. $E = 0.0213^{1.6}$. | 24. $C = 420\Lambda^{0.77}$. |
| 25. $C = 750\Lambda^{0.82}$. | 26. $\mu = 0.00014V^{0.54}$. | 27. $\mu = 0.15L^{-0.775}$. |

EXAMPLES.—LII. (Page 156.)

- | | | |
|--|---|--------------------------------|
| 1. $y = e^{1x}$. | 2. $y = 0.34e^{0.5x}$. | 3. $y = 270e^{-2x}$. |
| 4. $y = 20e^{-0.036x}$. | 5. $y = 325e^x$. | 6. $y = 2750e^{-x}$. |
| 7. $y = e^{0.1x}$. | 8. $y = 10e^{0.02x}$. | 9. $y = 3e^{0.025x}$. |
| 10. $\mu = 0.185$. | 11. $\mu = 0.172$. | 12. $\mu = 53500e^{-0.022t}$. |
| 13. $V = 0.01e^{0.000375t}$. | 14. $\Lambda = 30$; $\kappa = -0.000038$. | |
| 15. $\theta = 19.3e^{-0.0053t}$. | 16. $\theta = 20.65e^{-0.0003t}$. | |
| 17. $\log \theta = 2.07548 - 0.0006135t + 0.000001745t^2$. | | |
| 18. $s = 60e^{0.004t}$; $\log S = 1.78 + 0.17\frac{t}{100} - 0.044\left(\frac{t}{100}\right)^2$. | | |
| 19. $\mu = 0.028e^{-0.018t}$. | 20. $\mu = 0.043e^{-0.018t}$. | |

EXAMPLES.—LIII. (Page 166.)

- | | | | |
|-----------------------------------|---------------------|-----------------|--------------|
| 1. 2.33. | 2. 24.9. | 3. 27.65. | 4. 1005 lbs. |
| 5. 1041 lbs. | 6. 9.3 ft. per sec. | 7. 152 ft. | 8. 3.14 ins. |
| 9. 0.333. | 10. 0.637. | 11. 0.5. | 12. 20.11. |
| 13. 22.5 ft.-lbs. | 14. 11.8. | 15. 34.75. | 16. 8150. |
| 17. 10.8 sq. ins. | 18. 18.8. | 19. 674 sq. ft. | |
| 20. 1820, 2305, 2740, 3150, 3310. | 21. 10.7. | 23. 16.01. | |

EXAMPLES.—LIV. (Page 171.)

- | | | | |
|------------|--------------------|-------------------------------|---------------|
| 1. 2.5. | 2. 15 ft. per sec. | 3. 32.2 ft. per sec. per sec. | 4. -60. |
| 5. -12.5. | 6. 1.187. | 7. 0.222. | 8. 0.0000049. |
| 9. 0.1795. | 10. 0.010. | 11. 0.925. | 12. -0.799. |

EXAMPLES.—LV. (Page 181.)

- | | | | | |
|---|------------------------------|----------------------|---------|----------|
| 1. 3.5. | 2. 0.0435. | 5. 2005 ft. per sec. | 7. 3.2. | 8. 0.15. |
| 9. 11 ft. per sec. per sec.; 136.7 lbs. | 10. 59 ft. per sec. per sec. | 25. About £290. | | |
| 21. 1.00383; 1.00283. | | | | |

EXAMPLES.—LVI. (Page 190.)

- | | | | | |
|-------|---------|----------|-----------|------------|
| 1. 3. | 2. 0.5. | 3. -2. | 4. -0.75. | 5. 3. |
| 6. 4. | 7. -3. | 8. -0.6. | 9. -0.13. | 10. 0.253. |

11. a . 12. -3 . 13. $0\cdot5$. 14. $-1\cdot2$. 15. -3 .
 16. z . 17. $0\cdot00366V_0$. 18. $\frac{1}{R}$. 20. $2\cdot6$; 0 . 21. $\frac{l}{AE}$. 22. $2\cdot81$.

EXAMPLES.—LVII. (Page 194.)

1. $2x$. 2. $4x^2$. 3. $\frac{3\sqrt{x}}{2}$. 4. $-\frac{1}{x^2}$. 5. $-\frac{2}{x^3}$.
 6. $1\cdot324^{0\cdot32}$. 7. $\frac{-1\cdot5}{x^{2\cdot5}}$. 8. $1\cdot2516^{0\cdot25}$. 9. $\frac{1}{2\sqrt{u}}$. 10. $8\cdot33^{0\cdot8}$
 11. $0\cdot3^{1-0\cdot7}$. 12. $-\frac{1152}{v^3}$. 13. $-\frac{c}{p^2}$. 14. $2at$.

EXAMPLES.—LVIII. (Page 195.)

1. $6x - 2$. 2. $-5 - 12x$.
 3. $24x^3 - 15x^4 + 28x^2 - 3x^2 + 4x - 1$. 4. $21x^6 - 81x^3 + 30x^4 - 1$.
 5. $9x^2 - 4x + 5x^4$. 6. $5 + 12t$.
 7. $b + 2ct$. 8. $3z^2 + \frac{2t}{b_2^3}$.
 9. $1\cdot57x^{0\cdot21} - 4\cdot6x^{1\cdot3} + 13\cdot8x^{2\cdot6} - 1$. 10. $-\frac{2\cdot73}{x^{1\cdot1}} - \frac{1}{\sqrt{x}} + 3\cdot75x^{-\frac{1}{2}}$.
 11. $3\cdot9x^{0\cdot3} - 25\cdot2x^{-4\cdot6} - \frac{5}{2x\sqrt{x}} + \frac{13\cdot8}{x^{2\cdot3}}$.
 12. $2\cdot5x^{1\cdot5} - 1\cdot36x^{0\cdot36} + 8\cdot7x^{1\cdot9} - 0\cdot013x^{-0\cdot937}$.
 13. $1\cdot3x^{0\cdot3} + \frac{2\cdot6}{x^{3\cdot6}} + 7x^a + \frac{3}{x^4}$. 14. $1\cdot5u^{0\cdot5} + \frac{4\cdot6}{u^{3\cdot3}} - \frac{1}{4u^{\frac{1}{3}}}$.
 15. $\frac{1}{2\sqrt{u}} - \frac{1}{u^2} + 1$. 16. $1\cdot7x^{0\cdot7} + \frac{0\cdot3}{x^{1\cdot3}} + 5x^{1\cdot8}$.
 17. $\frac{1}{2\sqrt{x}} - \frac{1}{4x^{\frac{2}{3}}} - \frac{5x^{\frac{2}{3}}}{2}$. 18. $\frac{-4}{x^3} + \frac{1}{x^2} - \frac{9}{x^4} + \frac{2}{x^5}$.
 19. $6x - 3 - \frac{1}{3x^{\frac{1}{3}}} + \frac{1}{5x^{\frac{6}{5}}}$. 20. $5r^4 - 9r^2 + \frac{1}{8}r^{-\frac{1}{2}}$.
 21. $42t^3 - \frac{6}{t^4} - \frac{4}{t^2} - \frac{1}{2\sqrt{2t^{\frac{2}{3}}}}$. 22. $-2\cdot364v^{-3\cdot364} - \frac{2\cdot731}{2^{\frac{1}{2}\cdot731}} - 15v^a$.
 23. $1 - \frac{2}{z^2} + \frac{10}{z^3}$. 24. $0\cdot2x^{-0\cdot8} + 1\cdot6x^{-0\cdot2} - 4\cdot6x^{3\cdot6} - 22\cdot5x^{-2\cdot5}$.
 25. $-\frac{510}{u^{2\cdot0648}}$. 26. $-\frac{\kappa}{v^2}$; $-\frac{\kappa}{p^2}$. 27. $-308\cdot5\rho^{-1\cdot939}$. 28. $3x^2$, $6x$, 6 , 0 , 0 .
 29. 55 ft. per sec. ; 12 ft. per sec. per sec. 30. $10\frac{1}{8}$ f.s. ; $21\frac{1}{8}$ f.s.s.
 31. $32\cdot2$ f.s. ; $64\cdot4$ f.s. ; $96\cdot6$ f.s. ; $128\cdot8$ f.s. ; $32\cdot2$ f.s.s.
 32. Velocity = $32\cdot2t - 200$ ft. per sec. ; acceleration = $32\cdot2$ ft. per sec. per sec.
 33. Velocity = $2ct + b$; acceleration = $2c$.
 34. Momentum = $500 + 1680t$; kinetic energy = $625 + 4200t + 7056t^2$.
 35. $-\frac{C}{v^2}$. 36. $s = 1 + 4\cdot10^{-3}\theta + 9\cdot10^{-7}\theta^2$.
 37. $s = 0\cdot0947 + 0\cdot000994\theta - 0\cdot00000036\theta^2$.
 38. $\frac{dy}{dx} = \frac{W}{El}(lx - \frac{1}{2}x^2)$; $\frac{d^2y}{dx^2} = \frac{W}{El}(l - x)$; $\frac{d^3y}{dx^3} = -\frac{W}{El}$.

53. $\frac{w}{2EI}(l^2x - lx^2 + \frac{1}{3}x^3)$; $\frac{w}{2EI}(l^2 - 2lx + x^2)$; $\frac{w}{EI}(x - l)$; $\frac{w}{EI}$.
 54. $\frac{w}{2EI}\left(\frac{l^2x}{4} - \frac{x^3}{3}\right)$; $\frac{w}{2EI}\left(\frac{l^2}{4} - x^2\right)$; $-\frac{wx}{EI}$; $-\frac{w}{EI}$.

EXAMPLES.—LIX. (Page 200.)

3. $33 \cdot 8e^{13x}$. 4. $-13 \cdot 02e^{-3 \cdot 1x}$. 5. $-\frac{48}{e^{1 \cdot 5x}}$. 6. $-4e^{-2 \cdot 0x}$.
 7. $1 \cdot 3e^{1 \cdot 3u}$. 8. $1 \cdot 3e^{1 \cdot 3u+5}$. 9. $16 \cdot 1x^{4 \cdot 2} - 10 \cdot 4e^{5 \cdot 2x}$.
 10. $-bae^{-bu} + 2be^{2bu}$. 11. $1 \cdot 3e^{0 \cdot 3} - 10 \cdot 92x^{3 \cdot 2} - 10 \cdot 2e^{-2x}$.
 13. $1 \cdot 571 \times 4 \cdot 81x^2$. 14. $1 \cdot 666 \times 2 \cdot 3^{2x}$. 15. $1 \cdot 047 \times 2 \cdot 85^x$.
 16. $0 \cdot 839 \times 2 \cdot 5^t$. 17. e^x ; $9e^{3x}$; $a^{n \cdot a^x}$. 19. 0.
 20. 0. 21. $C = a_1 + a_2$; $D = a_1 a_2$. 24. V_1 .

EXAMPLES.—LX. (Page 204.)

1. $3 \cos 3x$. 2. $-2 \sin 2x$. 3. $\frac{1}{2} \cos \frac{1}{2}x$.
 4. $-\frac{1}{5} \sin \frac{x}{5}$. 5. $3 \sin(-3x)$. 6. $-\cos(-\frac{1}{3}x)$.
 7. $9 \cdot 4 \sin(-2 \cdot 35x)$. 8. $4 \cos(2x - 4)$. 9. $9 \sin(2 + 3x)$.
 10. $15 \cdot 5 \cos(2 \cdot 5 + 3 \cdot 1x)$. 11. $-6 \sin(1 - 3x)$. 12. $-30 \cos(2 - 5x)$.
 13. $0 \cdot 01 \sin(\frac{1}{3} - \frac{1}{4}x)$. 14. $0 \cdot 3517 \cos(0 \cdot 351x + 0 \cdot 273)$.
 15. $3 \cdot 89 \sin(3 \cdot 71 - 1 \cdot 52x)$. 16. $an \cos(nt + \epsilon)$.
 17. $A \rho \cos(\rho t + a)$. 18. $-A \rho \sin(\rho t + a)$.
 19. $A \epsilon \cos(\epsilon t + a) + B \epsilon \cos(\epsilon t - a)$. 20. $A \cos(\theta + \epsilon)$.
 21. $3 \cdot 09 \cos(1 \cdot 03t + 2 \cdot 51)$. 22. $2\pi f \cos(2\pi t / g)$.
 28. $\cos x, -\sin x, -\cos x, \sin x, \cos x$, and so on;
 $-\sin x, -\cos x, \sin x, \cos x, -\sin x, \dots$
 29. $-aq^2 \sin(qt + g)$. 30. $-12 \sin(2x + 4)$.
 31. $-21 \cdot 1 \cos(2 \cdot 6x - 4 \cdot 1)$. 33. 0. 34. 0.
 35. $\frac{dy}{dt} = ap \cos pt - bp \sin pt = -p\sqrt{a^2 + b^2} \sin(pt - a)$, where $\tan a = \frac{a}{b}$.
 36. Velocity = $2\pi na \cos(2\pi nt + g)$; acceleration = $-4\pi^2 n^2 a \sin(2\pi nt + g)$.
 38. Kinetic energy = $\frac{1}{2}Ma^2q^2 \cos^2 qt$; momentum = $Maq \cos qt$;
 force = $-Maq^2 \sin qt$.
 39. $10^{-8}AHq \cos qt$ volts.
 42. $a \cos t + 2b \cos 2t + 3c \cos 3t$; $-a \sin t - 4b \sin 2t - 9c \sin 3t$.
 43. Velocity = $rq \cos qt - \frac{r^2q}{2l} \sin 2qt$;
 acceleration = $-rq^2 \sin qt - \frac{r^2q^2}{l} \cos 2qt$; $-\frac{r^2q^2}{l}$; $-rq^2 + \frac{r^2q^2}{l}$; $-\frac{r^2q^2}{l}$.
 44. Velocity = $2\pi fa \cos(2\pi ft + g) + 3\pi fb \cos(3\pi ft + h)$;
 acceleration = $-4\pi^2 f^2 a \sin(2\pi ft + g) - 9\pi^2 f^2 b \sin(3\pi ft + h)$.

EXAMPLES.—LXI. (Page 207.)

1. $\frac{1}{x}$. 2. $\frac{4}{4x + 3}$. 3. $\frac{1}{x}$. 4. $\frac{-12}{1 - 2x}$.
 5. $\frac{15}{5x + 4}$. 6. $\frac{18 \cdot 2}{7x + 3}$. 7. $\frac{0 \cdot 4343}{u}$. 8. $-\frac{1}{x^2}$.

9. $\frac{2}{x^3}$. 10. $\frac{2}{x^2}$. 11. $\frac{2}{x^3}$. 16. $\frac{1}{t} - \frac{797}{t^2}$.
17. $\frac{0.737}{t} + 5.75 \cdot 10^{-4} \cdot t - 3150 \cdot 10^{-4}$.

EXAMPLES.—LXII. (Page 208.)

1. $5x^4 - \frac{1}{2}e^{\frac{1}{2}x} + \cos x$. 2. $11x^{10} - \frac{3}{e^{2x}} + 2 \sin 2x$.
3. $-1.7x^{-2.7} - \frac{1}{2}e^{-\frac{1}{2}x} + 3 \cos(3x + 2)$. 4. $-2.35e^{-2.35x} + 3.5x^{2.5} - 2 \sin(2x - 1)$.
5. $-1.2e^{-1.2x} + 0.6x^{-0.4} - 15 \cos(3x + 4) - 12 \sin(2x - 1)$.
6. $-2.3e^{-2.3t} - \frac{1}{2}t^{-\frac{3}{2}} + 5t^{-8} - 12 \sin(1 - 3t)$.
7. $2.6x^{0.3} + 2.1x^{-3.1} + 6e^{2x} + 6e^{-3x} + 2 \cos(2x + 1)$.
8. $11.6u^{1.7} + \frac{7.02}{u^{6.4}} + 2.53e^{1.1u}$.
9. $21.4u^{5.9} + 6.5 \cos(1 - 3u) - 21.5 \sin(2 - 4.3u) - \frac{3}{\sqrt{u}}$.
10. $3t^2 - 1 - \frac{1}{t^2} - 1.3t^{0.3} + 2.6t^{-3.6}$.
11. $5u^4 - 6e^{2u} + \frac{12}{e^{2u}} - 6e^{-u} - \frac{1}{2}\sqrt{e^u} + 3.6e^{1.2u}$.
12. $2e^{2t} - 6 \cos(2t + 1) - 12 \sin(3t - 2) - 4 \cos(1 - 4t) - 2 \sin(1 - t)$.

EXAMPLES.—LXIII. (Page 210.)

1. $-e^{-2x}(\sin x + 2 \cos x)$. 2. $e^{-3x}\{\cos(x - 1) - 3 \sin(x - 1)\}$.
3. $-e^{-6x}\{2 \cos(3 - 2x) + 5 \sin(3 - 2x)\}$. 4. $\frac{\sin 2x}{x + 1} + 2 \cos 2x \log_0(x + 1)$.
5. $3 \cos 3x \cos 5x - 5 \sin 3x \sin 5x$. 6. $28 \cos 4x \cos 6x - 42 \sin 4x \sin 6x$.
7. $70 \sin 3x \cos 7x + 30 \cos 3x \sin 7x$. 8. $-75 \cos 6x \sin 5x - 90 \sin 6x \cos 5x$.
9. $-3 \sin(2x + 1) \sin(3x + 2) + 2 \cos(2x + 1) \cos(3x + 2)$.
10. $-3 \sin(3x + 1) \cos(4x - 5) - 4 \cos(3x + 1) \sin(4x - 5)$.
11. $2 \sin(2x + 1) \cos(2x + 3) + 2 \cos(2x + 1) \sin(2x + 3)$.
12. $a \sin(ax + b) \cos(ax + d) + a \cos(ax + b) \sin(ax + d)$.
13. $-b \cos(ax + b) \sin(bx + c) - a \sin(ax + b) \cos(bx + c)$.
14. $-c \sin(ax + b) \sin(cx + d) + a \cos(ax + b) \cos(cx + d)$.
15. $x^3 \cos x + 3x^2 \sin x$. 16. $2x^{1.31} \cos(2x + 1) + 1.31x^{0.31} \sin(2x + 1)$.
17. $x^2 e^{2x}(2x + 3)$. 18. $x^{n-1} e^{bx}(bx + n)$. 19. o. 20. o. 21. o.

EXAMPLES.—LXIV. (Page 212.)

1. $-\frac{2 \cos 3x}{x^3} - \frac{3 \sin 3x}{x^2}$. 2. $-\frac{\sin(1 - 3x)}{x^2} - \frac{3 \cos(1 - 3x)}{x}$.
3. $-\frac{e^{-8x}}{2x\sqrt{x}} - \frac{3e^{-8x}}{\sqrt{x}}$. 4. $-\frac{2x^{1.5}}{e^{2x}} + \frac{1.5x^{0.5}}{e^{2x}}$.
5. $\frac{\cos x}{\log x} - \frac{\sin x}{x(\log x)^2}$. 6. $-\frac{\sin x + \cos x}{e^x}$.
7. $\frac{\sin x}{\cos^2 x}$. 8. $-\frac{\cos x}{\sin^2 x}$. 9. $-\frac{1}{\sin^2 x}$.
10. $-\frac{1}{x(\log x)^2}$. 11. $\frac{1}{\cosh^2 x}$. 14. $\frac{2}{e} \frac{2 \cos(2x - 3) - 3 \sin(2x - 3)}{e^{3x}}$.

15. $\frac{3 \cos(2x+3) \cos(3x-1) + 2 \sin(2x+3) \sin(3x-1)}{\cos^2(2x+3)}$.
16. $2e^{-2x} \frac{\sin(2x+3) - \cos(2x+3)}{\cos^2(2x+3)}$.
17. $\frac{6e^{3x}}{\log_e(x-1)} - \frac{2e^{3x}}{(x-1)\{\log_e(x-1)\}^2}$.
18. $\frac{11-x}{(x+5)^2}$.
19. $\frac{2 \cos 2x}{\log(x-3)} - \frac{\sin 2x}{(x-3)\{\log(x-3)\}^2}$.
20. $6e^{2x} \frac{\sin(2x-1) + \cos(2x-1)}{\cos^2(2x-1)}$.
21. $\frac{\cos(31x+7) + 31(x-4) \sin(31x+7) \cdot \log(x-4)}{(x-4) \cos^2(31x+7)}$.

EXAMPLES.—LXV. (Page 215.)

- | | | |
|---|---|-----------------------------------|
| 1. $-4(2-x)^2$. | 2. $\frac{1}{(1-x)^2}$. | 3. $\frac{-3}{(2+3x)^2}$. |
| 4. $\frac{3}{(2-3x)^2}$. | 5. $\frac{-3}{2\sqrt{4-3x}}$. | 6. $\frac{1}{\sqrt{2x+1}}$. |
| 7. $\frac{1}{(5-2x)^2}$. | 8. $\frac{2x+2}{\sqrt{2x^2+4x-1}}$. | 9. $\frac{x}{\sqrt{a^2+x^2}}$. |
| 10. $\frac{2x-3}{2\sqrt{x^2-3x+5}}$. | 11. $\frac{2ax+b}{2\sqrt{ax^2+bx+c}}$. | 12. $\frac{2}{2x+1}$. |
| 13. $\frac{-4}{3-4x}$. | 14. $\frac{-1}{1-x}$. | 15. $\frac{2x-2}{x^2-2x+5}$. |
| 16. $\frac{4x-3}{2x^2-3x+4}$. | 17. $\frac{2ax+b}{ax^2+bx+c}$. | 19. $3 \sin^2 x \cos x$. |
| 20. $3x^2 \cos x^2$. | 21. $\frac{3}{x}$. | 22. $\frac{3}{x}(\log_e x)^2$. |
| 23. $3x^2 e^{x^3}$. | 24. $3e^{3x}$. | 25. $5 \sin^4 x \cos x$. |
| 26. $-\tan x$. | 27. $2 \cos 2x \cdot e^{\sin 2x}$. | 28. $-e^{\sin^2}$. |
| 29. 1. | 30. $-6 \cos^2(2x-1) \sin(2x-1)$. | |
| 31. $\frac{3 \cos(3x+2)}{\sin(3x+2)}$. | 32. $\frac{1}{\sin x \cos x}$. | |
| 33. $2 \sin x \cos^4 x - 3 \cos^2 x \sin^3 x$. | | 34. $\frac{3 \sin x}{\cos^4 x}$. |
| 35. $m \sin^{m-1} x \cos^{n+1} x - n \sin^{m+1} x \cos^{n-1} x$. | | 38. $\frac{1}{x}$. |
| 39. $\frac{1}{\sqrt{x^2+a^2}}$. | 40. $\frac{1}{x^2-a^2}$. | 41. $\frac{1}{(x+2)(2x+3)}$. |
| 42. $\frac{x+1}{(x-4)(2x-3)}$. | | |

EXAMPLES.—LXVI. (Page 218.)

- | | |
|---|---|
| 1. 15'71 cub. ins. | 2. 0'00175 cos θ ; 0'00175; 0'0000306. |
| 3. $\delta a = \frac{bc \sin A}{a} \delta A$, $\delta a = \frac{c-b \cos A}{a} \delta c$. | |
| 4. 31'56. | 5. $150\sqrt{h}$; $A = 1800\sqrt{h}$. sq. ft. |
| 6. 5'43; 3'49; 5'43. | |

Answers to the Examples

EXAMPLES.—LXIX. (Page 228.)

1. 1. 2. 3. 3. 0.7071. 4. 3.58; 6.42. 5. 0.466.
 6. 2; 5. 7. -1; 3. 8. 0.716. 9. $\theta = \frac{\pi}{2}$
 10. Width = 2 ft.; depth = 1 ft. 11. Height = 3.175 cms.; volume = 67.1 cc.
 12. 1; 2. 13. 3.4 ins. 15. 8.66 knots.
 16. Breadth = 0.577 ft. 17. Breadth = 6 ins.
 18. 16 in series; current = 6.93 amperes. 19. 1.5 ohms.
 20. 5.55 amperes. 23. 31°. 24. 3r. 4d.

EXAMPLES.—LXX. (Page 233.)

1. 3 minimum, $\frac{4}{3}$ maximum. 2. 4 minimum, -1 maximum.
 3. 2 maximum, 7, 0 minima. 4. 1 maximum, -1, 4 minima.

EXAMPLES.—LXXI. (Page 234.)

1. x^3 . 2. $\frac{x^3}{3}$. 3. $\frac{x^3}{5}$. 4. $\frac{x^{n+1}}{n+1}$.
 5. e^{ax} . 6. $\frac{1}{5}e^{5x}$. 7. $\frac{3}{8}e^{8x}$. 8. $\frac{a}{b}e^{bx}$.
 9. $\sin x$. 10. $\sin(3x+1)$. 11. $\frac{1}{3}\sin(3x+1)$.
 12. $\frac{2}{3}\sin(3x+1)$. 13. $\frac{a}{b}\sin(bx+c)$. 14. $\cos x$.
 15. $-\cos x$. 16. $-\cos(2x-3)$. 17. $-\frac{1}{2}\cos(2x-3)$.
 18. $-\frac{5}{2}\cos(2x-3)$. 19. $-\frac{a}{b}\cos(bx+c)$. 20. $\frac{1}{x+5}$.
 21. $\log_e(x+5)$. 22. $\log_e x$. 23. $\Lambda \log_e(x+b)$.

EXAMPLES.—LXXII. (Page 236.)

1. $\frac{x^4}{4}$. 2. $\frac{x^{11}}{11}$. 3. $-\frac{1}{x}$. 4. $-\frac{1}{4x^4}$. 5. $\frac{2}{3}x^{\frac{2}{3}}$.
 6. $\frac{x^{2.6}}{2.6}$. 7. $10x^{0.1}$. 8. $-\frac{1}{0.13x^{0.13}}$. 9. $3x$. 10. x .
 11. cx . 12. $\frac{u^7}{7}$. 13. $-\frac{3}{2y^2}$. 14. $\log_e u$. 15. $-\frac{1}{3u^2}$.
 16. $\frac{1}{2}u^4$. 17. $-\frac{1}{0.064u^{0.064}}$. 18. $2\sqrt{u}$. 19. $-\frac{1}{0.14v^{0.14}}$.
 20. $-\frac{2}{\sqrt{y}}$. 21. $5 \log_e v$. 22. $\frac{c^{b+1}}{b+1}$. 23. $\frac{2}{3}e^{2x}$.
 24. $-\frac{3}{2e^{2x}}$. 25. $\frac{3}{4}e^{4t}$. 26. $-1.13e^{-1.2u}$.
 27. $-\frac{2t}{k}e^{-\frac{k}{2}t}$. 28. $-\cos(x-3)$. 29. $\sin(x-2)$.
 30. $-2 \sin(1-x)$. 31. $-2 \cos u$. 32. $3 \sin y$.
 33. $\frac{4}{3}\sin(3x+2)$. 34. $-\frac{3}{2}\cos(2x-1)$. 35. $-0.482 \cos(2.7t - 1.5708)$.
 36. $-0.52 \cos(2.5\theta + 6)$. 37. $-0.77 \sin(1-3\theta)$.
 38. $-\frac{A}{2\pi f} \cos(2\pi ft + c)$. 39. $\frac{A}{\pi} \sin(\pi ft + c)$.

40. $\frac{\pi m^2 x^3}{3}; 2\pi a x^2.$ 41. $\frac{k b^2 y^2}{2}.$ 42. $-\frac{a}{c+5b} \cos(\theta t + cx).$
 43. $\frac{\rho_1 v_1 \gamma}{(1-\gamma)v_1^{-1}}.$ 44. $\frac{bx^3}{3} + \frac{cx^2}{2}.$ 45. $\frac{mx^4}{4} + \frac{cx^3}{3}.$
 46. $\frac{C}{(1-\gamma)v^{\gamma-1}} = \frac{\rho v}{1-\gamma}.$ 47. $-\frac{\rho v}{0.37}; \rho v \log_e v; 5\rho v.$
 48. $\frac{3}{4}x.$ 49. $x^3 + x^2 - x + C.$ 50. $-\cos 2x + 4x + C.$
 51. $e^{2x} + 5x + C.$ 52. $\log_e(1+x) + 0.3x^4 - \frac{1}{3} \cos(3x+1) + 2.6x + C.$
 53. $x^3 - x^2 + 4x.$ 54. $t^4 - t^3 + t^2 - t.$
 55. $t^3 + 2t^2 - 5t.$ 56. $0.33x^3 + 1.5x^2 - 1.74x^{2.3} - 2x.$
 57. $\frac{s^4}{4} - \frac{s^{1.3}}{1.3} - 1.03s^3 + \frac{1}{s^2} - 5s.$ 58. $0.435s^{2.3} - \frac{as^3}{3} + \frac{2b}{3} \cdot s^{\frac{3}{2}} + cx.$
 59. $\frac{5}{6}u^n + \frac{a}{d} \cos(c+du) + \frac{b}{c} \sin(a+cu) + 2.31e^{2.3u} - e^{5u}.$
 60. $\frac{2a}{c} \cos(b-3ct) + \frac{1.925}{b} ce^{-2.6ct} - \frac{1.3c}{b} \log_e t - \frac{1}{8} c^{\frac{1}{2}} t^{\frac{5}{2}}.$ 61. $\pi \left(\frac{a^2 x^2}{2} - \frac{x^4}{4} \right).$
 62. $\frac{dy}{du} = 3u^2 - 6u + 6e^{3u}, \int y^u du = \frac{u^4}{4} - u^3 + \frac{2}{3} e^{3u}.$
 63. $\frac{dy}{dx} = \frac{1}{8} x^8 + 5x + C; y = \frac{1}{4} x^7 + \frac{5}{2} x^2 + Cx + D.$
 64. $\rho v^u = C.$ 65. $y = \frac{W}{EI} \left(\frac{1}{2} l x^2 - \frac{x^3}{6} \right).$
 66. $y = \frac{w}{24EI} (6l^2 x^2 - 4lx^3 + x^4).$ 67. $y = \frac{x^3}{3} + C$ where C is any constant.

EXAMPLES LXXIII. (Page 240.)

NOTE.—The accuracy attained in graphic integration varies with the character of the data and the scale used.

1. 17.45. 2. 2418, 860. 3. 8, 80, 360, 1050, 2550. 4. 337.
 5. 142.9. 6. 1528. 7. 660.4. 8. 426.

EXAMPLES LXXIV. (Page 244.)

1. 129,500 ft.-lbs. 2. 221. 3. 199.
 4. 235. 5. 337 ft.-lbs. 6. 12.3 ft. per sec.
 7. 280 ft.; 100 ft. 8. 24.2 ft. per sec; 18.25 ft. per sec.
 9. 194.5 lbs.; 265 lbs. 10. 20.0406. 11. 27.0238.

EXAMPLES LXXV. (Page 251.)

1. 48.4. 2. 2.303. 3. 1. 4. 5.16.
 5. 0.7854. 6. 3.1416. 7. 303. 8. 9.
 9. 0.3927. 10. 0.0737. 11. 1.571. 12. 0.667.
 13. 0.848. 14. 20,720. 15. 12,300. 16. 0.

EXAMPLES LXXVI. (Page 255.)

3. 24.

EXAMPLES.—LXXVII. (Page 260.)

1. 6.09; 4.40. 7. 100 ft.
 9. (a) 9.7 ft. per sec.; (b) 20 ft. per sec.; (c) 21.4 ft. per sec.

10. 13'9 ft. ; 78 ft. ; 140 ft. 16. 79'5 lbs. 18. 79'5 lbs.
 19. 3000 lbs. 20. 20,000 in.-lbs. 21. $1'45 \times 10^{-2}$ in.

EXAMPLES.—LXXVIII. (Page 268.)

1. 21'33. 2. 156. 3. -7'5. 4. 3. 5. -3.
 6. $5\frac{1}{3}$. 7. 7'98. 8. 6'583. 9. 0'48. 10. $\frac{1}{6}$.
 11. 13'22. 12. 396. 13. 4'05. 14. 0'81. 15. 1'718.
 16. 4'671. 17. 0'468. 18. 0'4295. 19. 3'1945. 20. 5'154.
 21. 1'656. 22. 12'778. 23. 1'298. 24. 0'4323. 25. -3'1945.
 26. -0'4323. 27. 1'62. 28. 0'6847. 29. 2'175. 30. 1'7071.
 31. -0'134. 32. 0'6628. 33. -1'8192. 34. 0'5. 35. 0'2929.
 36. $\frac{1}{3}$. 37. 0'5858. 38. 0'402. 39. 0. 40. 0'5402.
 41. 1'382. 42. 0. 43. 1. 44. 0'0784. 45. 0'3817.
 46. 0. 47. 0. 48. 20'794. 49. 51'0. 50. 60'825.
 51. 0'6931. 52. 0'1256. 53. $\frac{7}{24}$. 54. -0'223. 55. 0'0835.
 56. 0'5110. 57. 0'599. 58. 452'5. 61. $\frac{4}{3}$. 62. 4'5.
 60. 7812'5 ; mean value = 1562'5. 63. - $\frac{1}{3}$. 64. 9'6. 65. 1. 67. 268'2. 68. 0'5.
 69. 0'375. 70. 1612 ft.-lbs. 71. 7730 ft.-lbs.
 72. 11880 ft.-lbs. 73. 2'67 ft. 74. Velocity = $0'1(t + t^2 - t^3)$; 0'0625 ; 0'1.
 76. Bending moment = $1000x + 100x^2$.
 77. $\frac{dy}{dx} = 0'25 \cdot 10^{-n} \left(\frac{x^3}{3} + 5x^2 - \frac{5000}{6} \right)$
 78. $y = 0'25 \cdot 10^{-n} \left(\frac{x^4}{12} + \frac{5x^3}{3} - \frac{5000x}{6} + \frac{70000}{12} \right)$; $1'45 \cdot 10^{-i}$.
 79. $797 \log_5 \frac{t_1}{t_2} - (t_1 - t_2)$; $(t_2 + 797) \log_5 \frac{t_1}{t_2} - \left(1 - \frac{t_2}{t_1} \right) (t_1 + 797)$.

EXAMPLES.—LXXIX. (Page 274.)

1. 1'33. 2. 1'15. 3. 0'5. 4. 0'945.
 5. 0'632. 6. 1'175. 7. 1'175. 8. 1'718.
 9. $\frac{2A}{\pi}$. 10. 16'1 ft. per sec. ; 96'6 ft. per sec. 11. $\frac{2}{\pi}$.
 12. 0. 13. $\frac{AV}{2}$. 14. 0. 15. 0.
 16. 54'9. 17. 85 lbs. per sq. inch. 18. 884 lbs. per sq. foot.
 19. 1'27 lbs. 20. $\frac{ar}{2}$. 21. 0, 0, 2'545. 22. 100, 70'71, 0.
 24. 1'41. 25. 3'53. 26. 2'12. 27. 0'707.
 28. 0'707. 29. $\frac{A}{\sqrt{2}}$. 30. 70'7.
 31. $\sqrt{\frac{E^2 + a^2}{R^2} + \frac{a^2}{2}}$. 32. $\sqrt{\frac{A^2 + B^2}{2}}$. 33. $\sqrt{\frac{A^2 + B^2}{2}}$.

EXAMPLES.—LXXX. (Page 278.)

- | | | |
|---------------------------------------|---------------------------------------|---------------------------------------|
| 1. $5^{\circ}2', 18^{\circ}$ E. of N. | 2. $3^{\circ}4', 26^{\circ}$ N. of W. | 3. $5^{\circ}6', 31^{\circ}$ S. of W. |
| 4. $2^{\circ}3', 10^{\circ}$ E. of S. | 5. $3^{\circ}4', 39^{\circ}$ S. of E. | |

EXAMPLES LXXXI. (Page 279.)

- | | | | |
|-----------------------------|---|-------------------------------|--------------------------------|
| 1. $5^{\circ}12'_{100}''$. | 2. $8^{\circ}09'_{76}''$. | 3. $13^{\circ}96''$. | 4. $10^{\circ}5'_{60}''$. |
| 5. $0^{\circ}2'_{337}''$. | 6. 0. | 7. $10^{\circ}25'_{81}''$. | 8. $4^{\circ}875'_{120}''$. |
| 9. $53^{\circ}0''$. | 10. $7^{\circ}945', 35^{\circ}6^{\circ}$ N. of E. | 11. $32^{\circ}72'_{192}''$. | 12. $4^{\circ}57^{\circ}9''$. |
13. $51^{\circ}7'$ with AB; $83^{\circ}9$ units.

EXAMPLES.—LXXXIII. (Page 284.)

- | | | | |
|---|-------------------------|-----------------------------|--|
| 1. $0^{\circ}2'_{337}''$. | 2. $13^{\circ}96''$. | 3. $10^{\circ}5'_{60}''$. | 4. $1^{\circ}195'_{131}''7''$, $2^{\circ}8'_{322}''6''$. |
| 5. $4^{\circ}08'_{14}''5''$, $6^{\circ}89'_{104}''5''$. | 6. $259^{\circ}249''$. | 7. $21^{\circ}3'_{235}''$. | |
8. $125^{\circ}2$ ft. per sec. at an angle of 46° with BA.

EXAMPLES.—LXXXV. (Page 287.)

- | | |
|--|-----------------------------------|
| 1. $(0^{\circ}376', 318^{\circ}5^{\circ})$. | 2. $(12^{\circ}5', 40^{\circ})$. |
|--|-----------------------------------|

EXAMPLES.—LXXXVI. (Page 290.)

- | | | | |
|------------------------|----------------------------|--|-----------------------|
| 1. $4^{\circ}33'$. | 2. $-4^{\circ}33'$. | 3. $-4^{\circ}33'$. | 4. $4^{\circ}33'$. |
| 5. $2^{\circ}5'$. | 6. $2^{\circ}5'$. | 7. $-2^{\circ}5'$. | 8. $-2^{\circ}5'$. |
| 9. $14^{\circ}09'$. | 10. 0. | 11. $5^{\circ}29'$. | 12. $-8^{\circ}11'$. |
| 13. $-9^{\circ}36'$. | 14. $-7^{\circ}1'$. | 15. 0. | 16. $12^{\circ}47'$. |
| 17. $29^{\circ}343'$. | 18. $148, -148, -148, 148$ | 19. $-106^{\circ}1'; -46^{\circ}6'; 0; -118^{\circ}6'$. | |
| 20. 33506 ft.-lbs. | 21. $0^{\circ}824$ H.P. | 22. $7^{\circ}23$ H.P.; 0. | |
| 23. $3^{\circ}17'$. | 24. $12^{\circ}96'$. | | |

EXAMPLES.—LXXXVII. (Page 292.)

- | | | |
|---------------------------------------|--------------------------------------|--------------------------------------|
| 1. $19^{\circ}35'; 8^{\circ}2'$. | 2. $8^{\circ}2'; 19^{\circ}35'$. | 3. $22^{\circ}62'$. |
| 4. 0; 19° . | 5. $-13^{\circ}1'; 61^{\circ}6'$. | 6. $-61^{\circ}6'; 13^{\circ}1'$. |
| 7. $-19^{\circ}65'; -13^{\circ}77'$. | 8. $12^{\circ}66'; -34^{\circ}79'$. | 9. $34^{\circ}79'; -12^{\circ}66'$. |
| 10. $-26^{\circ}3'; 12^{\circ}25'$. | 11. $2^{\circ}92'_{22}''$. | 12. $3^{\circ}05'_{280}''28''$. |
| 13. $4^{\circ}55'_{130}''$. | 14. $5^{\circ}69'_{214}''$. | 15. $6^{\circ}88'_{310}''$. |

EXAMPLES.—LXXXVIII. (Page 293.)

- | | | |
|--|---|---------------|
| 1. $27^{\circ}9$ lbs., $21^{\circ}06$ lbs. | 2. $-31^{\circ}7$ lbs., $14^{\circ}8$ lbs. | |
| 3. $-33^{\circ}45$ lbs., $-10^{\circ}3$ lbs. | 4. $23^{\circ}85$ lbs., $-25^{\circ}6$ lbs. | |
| 5. $42^{\circ}434'_{45}''$ lbs. | 6. $210^{\circ}942'_{3}''$ lbs. | 7. 448 lbs. |
| 8. $10^{\circ}6$ miles an hour. | 9. $0^{\circ}5$ ft. per sec. | |
| 10. 1739 ft. per sec.; 466 ft. per sec. | 11. 523 lbs. | |

EXAMPLES.—LXXXIX. (Page 295.)

1. $a + b = 6.46$; $c(a + b) = 24.7$.

EXAMPLES.—XC. (Page 296.)

11. 5.75_{100}° lbs.

12. 8.73_{50}° .

13. 500_{200}° .

14. Length, 390 links; angle 80° ; distance from F = 380.

15. 560 links; 90° .

EXAMPLES.—XCII. (Page 302.)

1. (a) 7970; (b) 5657; (c) 697.6. 2. (a) 17,540; (b) 15,740; (c) 12,280; (d) 628.2.

3. 108.45.

4. 63.77.

5. 19272.

6. 1 : 0.77.

EXAMPLES.—XCIII. (Page 305.)

1. 6.237.

2. 34.25.

3-4. 32.2.

5-8. 7.22.

9. 0.0652 volt.

10. 2003 dynes.

EXAMPLES.—XCV. (Page 312.)

1. 2.36; 2.28; 2.29.

2. 1.13; 1.40; 2.40.

3. - 1.06; 1.84; 2.12.

4. 1.705; 1.53; 3.28

5. 2.42; 0.695; 1.97.

6. 0.530; 0.883; 1.71.

7. 0.719; 1.06; 1.53.

8. 1.06; 1.06; 2.60.

9. 0.758; 0.970; 1.58.

10. 0.533; 0.682; - 0.500.

11. 0; - 1; 0.

12. - 1.40; 2.25; 1.41.

EXAMPLES.—XCVI. (Page 313.)

1. 10.247 ; 60.8° ; 26.5° .

2. 11.88 ; 70.3° ; 26.5° .

3. 4.9 ; 114° ; 26.5° .

4. 9.64 ; 58.8° ; 14.1° .

5. 10.77 ; 42° ; 33.7° .

6. 1.73 ; 54.7° ; 45° .

7. 3.74 ; 74.5 ; - 33.7° .

8. 7.81 ; 67.1° ; 33.7° .

9. 25.475 ; 54° ; 29° .

10. 8.775 ; 70° ; - 14° .

11. 13; 108° ; - 14° .

EXAMPLES.—XCVII. (Page 316.)

1. $l = 0.912$, $m = 0.342$, $n = 0.228$; $\alpha = 24.2^{\circ}$, $\beta = 70^{\circ}$, $\gamma = 76.8^{\circ}$.

2. 54.2° with Oyz ; 18.9° with Ozx ; 29° with Oxy ; 3.61.

3. 0.384; 0.512; 0.768.

4. 8.60 ins.; 69.5° ; 62.3° ; 35.5° .

5. $l = 0.652$; $m = 0.528$; $n = 0.545$.

6. $\alpha = 40.7^{\circ}$; $\beta = 77.5^{\circ}$; $\gamma = 52^{\circ}$.

7. $\alpha = 74.6^{\circ}$; $\beta = 63.8^{\circ}$; $\gamma = 31^{\circ}$.

8. 3.83.

9. 1.85; 1.99; 1.27.

10. 1.812; 1.375; 2.685.

11. 66.2° .

12. 36.3° .

13. 48.3° .

14. 40.3° .

15. 38.7° .

EXAMPLES.—XCVIII. (Page 317.)

- | | |
|---------------------------------|-------------------------------|
| 1. 4'12; 0'485; 0'728; 0'485. | 2. 5'38; 0'744; 0'372; 0'558. |
| 3. 2'45; 0'817; 0'408; - 0'408. | 4. 4'36; 0'688; 0'229; 0'688. |
| 5. 3; 0'667; 0'333; 0'667. | 6. 73°; 2'97; 1'17; 2'41. |
| 7. 3'97; 2'17; 3'41. | 8. 11'51; 5'57; 7'47. |

EXAMPLES.—XCIX. (Page 319.)

- | | | | |
|---|------------------|------------------|-------|
| 1. 61°; 43'25°; 61°; 41'9°; 68'15°; 57'45°; 35'2°; 65'9°; 65'9°; 46'5; 76'75°; 46'5°. | 3. 3'742; 53°. | 4. 4'123. | 5. 5. |
| 2. 3'605; 4'54; 2'237; 3'161. | 7. 46'7°; 29'0°. | 8. 29'0°; 3'605. | |
| 6. 3'742. | | | |
| 9. 3'54 on Oyz; 4'55 on Ozx; 4'10 on Oxy. | | | |

EXAMPLES.—C. (Page 321.)

- | | | | | |
|-----------|---------------------------------------|----------------|-----------|-----------|
| 1. 21°. | 2. 35°. | 3. 36°; 0'620. | 4. 25°. | 5. 32'3°. |
| 6. 62'7°. | 7. 33'3°; 2'08; 98'3°; 16'25°; 76'1°. | 8. 72. | 9. 21'7°. | |

EXAMPLES.—CI. (Page 325.)

- | | |
|-------------------------------|---|
| 3. 1'537; 31°; 50°; 59°; 40°. | 4. 2'45; 72'2°; 60'7°; 35'2°; 54'8°; 60'7°. |
|-------------------------------|---|

EXAMPLES.—CII. (Page 326.)

2. In Oxy $x = 1'36$, $y = 2'19$; in Oyz $y = 6$, $z = -3$; in Ozx $z = 1'71$; $x = 2'14$.

EXAMPLES.—CIII. (Page 327.)

- | | |
|-----------|---------|
| 1. 12'3°. | 2. 21°. |
|-----------|---------|

EXAMPLES.—CIV. (Page 329.)

- | | | |
|------------------------------------|--------------|----------------------------|
| 1. 23,570 cub. ft. | 2. 1656 lbs. | 3. 28,250,000; 17,200,000. |
| 4. 2'12 × 10 ⁹ ft. lbs. | | 5. 4,900,000 gallons. |
| 6. 38,500 cub. ft.; 430 tons. | | 7. 38,100 cub. ft. |

EXAMPLES.—CV. (Page 334.)

- | | | | |
|--|--------------------|-----------|-----------|
| 1. 37'7 cub. ins. | 2. 88 cub. ins. | 3. 109'1. | 4. 100'5. |
| 5. 498; 67. | 6. 245'1 cub. ins. | 8. 151. | 9. 11'6. |
| 10. $\frac{\pi n^2}{2n} \{e^{2n(b-a)} - 1\}$. | 11. 6'28. | | |

EXAMPLES.—CVI. (Page 336.)

1. 470 cub. ins. 2. 6230 cub. ins. 3. 13·3 cub. ins.
 4. 15·4. 5. 16·3 cub. ft. 6. 3110 lbs.

EXAMPLES.—CVII. (Page 341.)

1. $1\frac{1}{3}$ in. from base. 2. $\bar{x} = 0\cdot6$; $\bar{y} = 0\cdot375$. 3. $\bar{x} = 2\cdot657$; $\bar{y} = 1\cdot607$.
 4. $\bar{x} = \frac{4}{7}$; $\bar{y} = \frac{2}{5}$. 5. $\bar{x} = 1\cdot518$; $\bar{y} = 0\cdot565$. 6. $\bar{x} = 15\cdot43$; $\bar{y} = 0\cdot4$.
 7. $\bar{x} = \frac{a(h_2 + 2h_1) + b(2h_2 + h_1)}{3(h_1 + h_2)}$; $\bar{y} = \frac{h_1^2 + h_1h_2 + h_2^2}{3(h_1 + h_2)}$.
 8. 0·628. 9. 1·875.
 10. On the middle radius at distance $\frac{2}{3}\pi$ from the centre.
 11. $\bar{x} = 1\cdot875$; $\bar{y} = 1\cdot25$.

EXAMPLES.—CVIII. (Page 343.)

1. $\bar{x} = 3\cdot23$. 2. 3·425. 3. 32·15. 4. 4·039.
 5. 2·95; 2·88. 6. 1·7 ins. from bounding radii. 7. $\bar{x} = 0$; $\bar{y} = \frac{4}{3\pi}$.
 8. On the line joining mid points of **BC** and **AD**, and distant 0·192 ft. from **AD**.

EXAMPLES.—CIX. (Page 345.)

1. 2·62; 5·13. 2. 40·9; 28·9. 3. 44·3; 28·9.
 4. On the middle radius at distance 2·55 ins. from the centre. 5. 0·11 in.

EXAMPLES.—CX. (Page 349.)

1. 4·5 from vertex. 2. 4·821 from vertex. 4. 5·64 in. 5. 3·44 in.
 6. $\bar{x} = 2\cdot249$. 7. $\bar{x} = 10\frac{2}{3}$. 8. $\bar{x} = 6\cdot82$.

EXAMPLES.—CXI. (Page 351.)

1. $\bar{x} = 5\cdot28$. 2. $\bar{x} = 4\cdot56$; 1·875 in. from centre. 4. 133 ft.
 5. 91 ft. from water level.

EXAMPLES.—CXII. (Page 353.)

1. 3175 lbs. 2. 200 cub. ins. 4. 359 sq. ins.; 116·5 cub. ins.
 5. 107·8 lbs. 6. 3·43 lbs.

EXAMPLES.—CXIII. (Page 356.)

1. 85·2 ft.-lbs.; 4·59 ins. 2. $M\frac{a^2 + b^2}{2}$.
 3. 0·326, taking engineering unit of mass; 17·88 ft.-lbs. 4. 0·994.

EXAMPLES.—CXIV. (Page 358.)

1. 2.12 ins. 2. $\frac{5}{4}a^2$. 3. 5.55. 4. 2.42. 5. 48.33. 6. 6130 ft.-lbs.;
1650 ft.-lbs. 7. 0.0203.

EXAMPLES.—CXV. (Page 361.)

1. 702. 2. 330.

EXAMPLES.—CXVI. (Page 364.)

1. $axx^{n-1}y^m$; $amx^n y^{m-1}$. 2. $abyc^{bxy}$; $abxc^{bxy}$; $ab^{.bx+cy}$; ace^{b1+cy} .
3. $ab \cos (bx + cy)$; $ac \cos (bx + cy)$; $-ab \sin (bx + cy)$; $-ac \sin (bx + cy)$.
4. $\frac{\partial z}{\partial x} = 6x - 2y$; $\frac{\partial z}{\partial y} = -2x$.
6. $\frac{\Lambda n \pi}{l} \cos \left(\frac{n \pi x}{l} \right) \cos \left(\frac{n \pi ct}{l} + a \right)$; $-\frac{\Lambda n \pi c}{l} \sin \left(\frac{n \pi x}{l} \right) \sin \left(\frac{n \pi ct}{l} + a \right)$.
7. $-\frac{RT}{v^2}$; $\frac{R}{v}$; $\frac{R}{\rho}$; $\frac{p}{K}$. 8. $\frac{x}{r}$; $\frac{y}{r}$; $\frac{z}{r}$.

EXAMPLES.—CXVII. (Page 367.)

1. 38.08 lbs. per sq. ft. 2. -4.41° . 3. -0.0705 cub. ft.
4. $\delta x = r \cos \theta \cos \phi \delta \theta - r \sin \theta \sin \phi \delta \phi$.

EXAMPLES.—CXVIII. (Page 369.)

1. $5x^4 - 9x^2y^2 - 6xy^3$; $-6x^3y - 3x^2 + 4y^3$; $20a^3 - 18xy^2 - 6y$; $-6a^3 + 12y^3$;
 $-18x^2y - 6x$.
2. $6 \cos (2x + 3y) - 2ye^{xy}$; $9 \cos (2x + 3y) - 2xe^{xy}$; $-12 \sin (2x + 3y) - 2y^2e^{xy}$;
 $-27 \sin (2x + 3y) - 2x^2e^{xy}$; $-18 \sin (2x + 3y) - 2xy^2e^{xy}$.

EXAMPLES.—CXIX. (Page 371.)

1. $\frac{x}{2} + \frac{\sin 2x}{4}$. 2. 39.09. 3. $\frac{1}{\sqrt{3}} \tan^{-1} \frac{x-2}{\sqrt{3}}$.
4. $\frac{1}{2\sqrt{29}} \log \frac{2x+3-\sqrt{29}}{2x+3+\sqrt{29}}$. 5. $\frac{1}{2} \tan^{-1} \frac{(x-1)}{2}$ 6. $\frac{1}{2} \log \frac{x-4}{x-2}$.

EXAMPLES.—CXX. (Page 374.)

1. $-\log \cos x$. 2. $\log \sin x$. 3. $\log \tan \left(\frac{x}{2} + \frac{\pi}{4} \right)$.
4. $\log (x^2 + x + 5)$. 5. $3 \log (x^2 + x + 5) + \frac{4}{\sqrt{19}} \tan^{-1} \frac{2x+1}{\sqrt{19}}$.
6. $\frac{5}{2} \log (x^2 + x + 5) - \frac{13}{\sqrt{19}} \tan^{-1} \frac{2x+1}{\sqrt{19}}$. 7. $\frac{1}{3} \cos^3 x$.
8. $\frac{1}{6} \sin^6 x$. 9. $\frac{1}{4} \tan^4 x$. 10. $\frac{\pi x^2}{4}$.

EXAMPLES.—CXXI. (Page 375.)

1. 0.507. 2. $\log_e \frac{x+3}{x+5}$. 3. $\log_e (x+1)(x+6)^2$.
4. $\log (x-1) + \log (x+2) - 2 \log (x+3)$.
5. $\log (x-3)(x+2) - 2 \log (2x+1)$.
6. $\log (x+1) + 2 \log (x-2) - \frac{1}{x+1}$.
7. $2 \log (x-1) + \log (x-4) + 4 \log (x+3) - \frac{3}{x-1}$.
8. $1.5 \log (2x-1) + \log (x^2+3x+4)$.
9. $3 \log (x-2) + \frac{3}{2} \log (x^2+x+3) - \frac{1}{\sqrt{11}} \tan^{-1} \frac{2x+1}{\sqrt{11}}$.

EXAMPLES.—CXXII. (Page 377.)

1. $x \sin x + \cos x$. 2. $-e^{-x}(1+x)$. 3. $\frac{x^2}{2} \log x - \frac{x^3}{4}$.
4. 0.675. 5. $\frac{x^3 \log x}{5} - \frac{x^3}{25}$. 6. $(x^2 - 2x + 2)e^x$.
7. $\frac{2\eta^2}{(k^2 + 4\eta^2)\pi} \left(1 - e^{-\frac{k\pi}{\eta}}\right)$. 8. $\bar{x} = 1$.

EXAMPLES.—CXXIII. (Page 381.)

1. $y = 0.25e^{12x}$. 2. $y = e^{12x}$. 3. 0.69 secs.
4. $\mathcal{L} 112.49$; $\mathcal{L} 112.616$; $\mathcal{L} 112.678$; $\mathcal{L} 112.75$. 5. $\theta = 20.7^{-0.006t}$.
6. $T = 25e^{0.085 \cdot 2t}$. 7. $q = q_0 e^{-\frac{t}{KR}}$, where q_0 is the initial charge; in $15 \cdot 10^{-3}$ secs.
8. $i = i_0 e^{-\frac{Rt}{L}}$, where i_0 is the current when $t = 0$.

EXAMPLES.—CXXIV. (Page 382.)

2. $y = Ae^{2x} - 3$. 3. $y = Ae^{2x} - 3$. 4. $y = Ae^{-12x} - \frac{3}{4}$.
5. $y = Ae^{2x} + 1\frac{1}{6}$. 6. $i = \frac{E}{R} \left(1 - e^{-\frac{Rt}{L}}\right)$; 14 amps.
7. $C = \frac{ELq}{\sqrt{R^2 + L^2}g}$.

EXAMPLES.—CXXV. (Page 387.)

1. 8.6 secs.

EXAMPLES.—CXXVI. (Page 393.)

1. $y = A_1 e^{-x} + A_2 e^{-4x}$. 2. $y = A_1 e^x + A_2 e^{4x}$. 3. $y = A_1 e^{-2x} + A_2 e^{2x}$.
4. $y = (A + Bx)e^{-2x}$. 5. $y = Ae^{-2x} \sin (x + B)$. 6. $y = A \sin (4x + B)$.
7. $x = a \sin \frac{t}{\sqrt{mh}}$; 0.39 sec. 8. $x = Ae^{-1.29t} \sin (15.75t + B)$.
9. (1) $\theta = Ae^{-\frac{t}{2I}} \sin \left(\sqrt{\frac{h}{I}} - \frac{k^2}{4I^2} t + B \right)$.
- (2) $\theta = A_1 e^{-\left(\frac{h}{2I} + \sqrt{\frac{k^2}{4I^2} - \frac{h}{I}}\right)t} + A_2 e^{-\left(\frac{h}{2I} - \sqrt{\frac{k^2}{4I^2} - \frac{h}{I}}\right)t}$.

EXAMPLES.—CXXVII. (Page 394.)

1. $y = Ae^{-0.4t} \sin(0.8t + B) + 4$.
2. $q = 0.0005 + 7.25 \cdot 10^{-5} e^{-8.875 \cdot 10^4 t} - 57.25 \cdot 10^{-5} e^{-1.125 \cdot 10^4 t}$ coulombs.
 $q = 0.0005 - 0.000707 e^{-10^4 t} \sin(10^4 t + B)$ coulombs.

EXAMINATION PAPERS.

1901. (Page 396.)

1. 7.44; 0.01255; 5.68; 1546.
2. 1.69; -0.299; -1.43. 10^{-9} .
3. See p. 127.
4. $n = 0.87$.
5. 10,360 cub. ins.; 6 cub. ft.
8. 329.8 sq. ins.; 0.1 per cent.
9. $x = 1.35$; $y = 3.70$; $z = 3.08$; $\alpha = 74.4^\circ$; $\beta = 47.2^\circ$; $\gamma = 52^\circ$.
11. See p. 174; 57.5 lbs.
13. $5Cv^{0.2}$; $C \log_e v$.
14. $\frac{\pi m^2(b^2 - a^2)}{2b}$.
15. $h = \frac{\gamma - s}{\gamma - 1} \rho$; $s = \gamma$.
16. $T = 40h^{1.46}$; $V = 1400h^{1.46}$.
17. $A = 2044h^{0.46}$; $\delta V = 170.3h^{0.46}$.
18. $n = 260$; $R = 0.882$.

1902. (Page 398.)

1. 3.123; 1704; 1.722; 0.0198.
3. -1.2 + 0.4x.
4. 3675; 2810; 2870
5. $U = 0.19C - 0.22$; $c = 5.265 + 0.0833\frac{1}{f}$.
6. $P = 31v^{1.77}$.
7. $3\frac{1}{2}$ per cent.
8. 8.15 ins.; 4.65 ins.; 3.68 per cent.; 44.5 cub. ins.
9. 7.477; 5.98; 5.0; 4.319.
11. $r = 3.904$; $\theta = 39.8^\circ$; $\phi = 36.8^\circ$; $\alpha = 59.1^\circ$; $\beta = 67.4^\circ$; $\gamma = 39.8^\circ$.
12. See p. 232.
13. $V = 3 \sin(600t) + 2.4 \cos(600t)$; ± 10 ; ± 3.84 .
14. See p. 142.

1903. (Page 400.)

1. 284.65; 2817; 4.5710; 1.5710; $\bar{2}$.5710; 3.339; 1.930; 1768000; 11.03.
2. (a) 3595; (b) -9.808; (c) 32.
3. 1.24; 0.604; 2.348; 3.579.
4. 33600 cub. ins.; 305 sq. ins.
5. 1.221.
6. Yes; 14.8×10^6 .
7. 4.35 ins. per annum; $10\frac{1}{2}$.
8. Anything up to £16.
9. $yx^{1.065} = 480$; 22.4.
10. 3.94 cub. ft.; 1687 sq. ins.
11. OP = 3.09, OQ = 2.47, PQ = 1.15; angle POQ = 20.1° .
12. See Chapter XXVI.
14. 106.2.

1904.

(Stage 2.) (Page 404.)

1. 0.3106 ; 37.32 ; 1.558 ; 1.694 ; 0.5900 .
2. 17.2 ; 0.2960 ; 1.7465×10^{-11} ; 8.41 .
3. 3.531 ; 8.454 ; 4.546 ; 8.67 ; 4.61 ; 101.8 .
5. $D = 29860$; $C = 7526$; $V = 24$; $P = 71680$.
7. $T = 40h^{1.46}$; $D = 1400h^{1.46}$.
9. $W = 16K + 4300$; $w = \frac{4300}{K} + 16$; 20.3 ; 30.3 .
11. 13880 ; 38.568 ; 6.428 .

(Stage 3.) (Page 406.)

1. 0.03106 ; 373.2 ; 1.521 ; 0.5900 ; 0.9563 ; -0.8480 ; 2.7475 .
2. 0.1774 ; 0.1777 ; 0.2 per cent.
3. 223.3 ; 12 yrs.
6. 2.91 ; 4.535 ; 3.067 ; 60.3° ; 57.3° .
7. $A = 1800h^{0.06}$.
8. $W = 5070 + 7.2Y$.
10. $am + \frac{bm^{n+1}}{n+1}$; 0.0718 ; 5.72 .
11. $\frac{2}{3}a$; $\frac{3}{2}a$.
12. $\rho \frac{\gamma^{-1}}{\gamma} = \frac{1-\gamma}{\gamma} \rho_0 c h + \rho_0 \frac{\gamma^{-1}}{\gamma}$; $c = \rho_0 \frac{1-\frac{1}{\gamma}}{\rho_0 K}$; $t = \frac{1-\gamma}{\gamma K} h + t_0$.
13. $\Lambda = 0.32850$ when $x = 1$.

1905.

(Stage 2.) (Page 409.)

1. (a) 0.06225 ; 40.55 . (b) 0.5105 ; 39.83 ; 0.02511 .
2. (a) 1.221 ; 1.221 ; 4 terms. (b) $\frac{2.3}{x-5.4} - \frac{1.8}{x+1.9}$.
- (c) 5.06 ; 7.48 . (d) 25° ; 13.69 ft.; 5.78 ft.
3. At 1 and 3.05 miles respectively.
4. 36.8° ; 75.7° ; 56.3° .
5. $670,000$.
6. 2.696 ; 1.387 ; 11.18 ; 14.83 ; 2173 ; 5604 .
7. 6.248 sq. ins.
10. 16 ins.; 366.5 cub. ins.
12. 2.35 .
13. $\frac{12000}{s} + 3s^2$; 12.6 knots.
14. 2.3 ; 2.8 ; 500 ft. per minute.

(Stage 3.) (Page 411.)

1. (a) 0.006225 ; 0.002466 ; (b) 3.857 ; 0.8753 ; (d) -0.9613 ; -0.5592 ; 0.2308 ; 13° ; 145° ; 104° .
4. 15.7 knots relative to the water.
5. 1.0914 ; 0.5286 ; 112.3 .
7. 50.26 sq. ins.
9. 0.801 (see p. 181).
10. $360.6 \sin(600t + 0.983)$; 56.3° .
11. $d = 10 - \frac{5}{8}x$; $\pi(25 - \frac{2}{3}x + \frac{2}{5}x^2)$; $\pi(25x - \frac{2}{3}x^2 + \frac{2}{5}x^3)$.
12. $h = C - \frac{c^2}{2gr^2}$.
13. 2.2 for first four observations; 4.3 for last three.
14. 654 ; 3180 ; 14270 ; 7.85 ; 14.4 ; 20.9 .

1908.

(Stage 2.) (Page 415.)

1. (a) 0·1917; 453·5; (b) 0·8212; (c) 27·49; 5·923; 0·2749; 0·1276; (d) 116·5.
2. (a) 9·78; 6·54; (b) 4·04 inches; 0·41 inches; (c) 6·74 inches; 14·84 inches;
- (d) $(x - 5·69)(x - 3·23)$.
3. (a) -33·6; 39·9; (b) 6 lbs.; (c) 2·25; 1800; 800.
4. *v*. Question 13, Stage 3. 5. 0·45. 6. 1·18.
9. $a(\beta - \alpha) + \frac{b(\beta^3 - \alpha^3)}{2} + \frac{c(\beta^3 - \alpha^3)}{3}$; $2h\left(\alpha + \frac{ch^2}{3}\right)$.
10. $a = y_2$; $b = \frac{y_3 - y_1}{2h}$; $c = \frac{y_1 + y_3 - 2y_2}{2h^2}$.
11. 2·6; 30·2. 12. $F = 260r - 20$; Error 0·5.
13. $5(20 + h)$; $\frac{5(20 + h)}{h}$; 180 - 9*h*.

(Stage 3.) (Page 417.)

1. (b) 49·85; (c) -0·4540; -0·5446; -0·7002; (d) $\frac{1}{x - 4·32} + \frac{1}{x + 5·70}$.
2. 0·977. 3. $W = 153K + 208,000$; $w = 153 + \frac{208,000}{k}$.
6. $S = wx + W - wl$; $M = w\frac{x^2}{2} + (W - wl)x + \left(\frac{wl^2}{2} - Wl\right)$.
 $\frac{dy}{dx} = \frac{wx^3}{6c} + \frac{W - wl}{2c}x^2 + \left(\frac{wl^2}{2} - wl\right)\frac{x}{c}$; $y = \frac{wx^4}{24c} + \frac{W - wl}{6c}x^3 + \left(\frac{wl^2}{2} - Wl\right)\frac{x^2}{2c}$.
7. $p = \left(\frac{1 - c}{c}kk + \Lambda\right)^{\frac{c}{2}-1}$, where *k* and Λ are constant; $t = \frac{1 - c}{c}k + \frac{\Lambda}{k}$.
8. 15 knots. 9. $a = 10·24$; $b = 16·38$; $c = 1·554$; area = 30·7.
11. $\frac{ab}{2} \cos c$.
13. (*v* p. 224) -1; -*i*; +1; *i*; 5·07 + 2·95*i*; 0·707 + 0·707*i*; 0·707 - 0·707*i*;
 5·87 sin(*qt* + 0·528); (*v*. Ex. 1, p. 42) sin(*qt* + 0·7854); sin(*qt* - 0·7854).
14. 0·00129*v*₀ sin(*qt* + 0·1108).

MATHEMATICAL TABLES

(A copy of these Tables is supplied to each candidate at the Examinations of the Board of Education in Practical Mathematics, Applied Mechanics, and Steam).

USEFUL CONSTANTS.

1 inch = 25·4 millimetres.

1 gallon = 0·1604 cubic foot = 10 lbs. of water at 62° F.

1 knot = 6080 feet per hour.

Weight of 1 lb. in London = 445,000 dynes.

One pound avoirdupois = 7000 grains = 453·6 grammes.

1 cubic foot of water weighs 62·3 lbs.

1 cubic foot of air at 0° C. and 1 atmosphere, weighs 0·0807 lb.

1 cubic foot of hydrogen at 0° C. and 1 atmosphere, weighs 0·00559 lb.

1 foot-pound = 1·3562 × 10⁷ ergs.

1 horse-power-hour = 33,000 × 60 foot-pounds.

1 electrical unit = 1000 watt-hours.

Joule's equivalent to suit Regnault's H, is $\begin{cases} 774 \text{ foot-pounds} = 1 \text{ Fahr. unit.} \\ 1393 \text{ foot-pounds} = 1 \text{ Cent. } \end{cases}$..

1 horse-power = 33,000 foot-pounds per minute = 746 watts.

Volts × amperes = watts.

1 atmosphere = 14·7 lbs. per sq. inch = 2116 lbs. per sq. foot = 760 mms. of mercury = 10⁶ dynes per sq. cm. nearly.

A column of water 2·3 feet high corresponds to a pressure of 1 lb. per sq. inch.

Absolute temp., $t = \theta^{\circ} \text{C.} + 273\cdot7^{\circ}$.

Regnault's H = 606·5 + 0·305 $\theta^{\circ} \text{C.} = 1082 + 0\cdot305 \theta^{\circ} \text{F.}$

$\rho u^{1\cdot0648} = 479$.

$\log_{10} \rho = 6\cdot1007 - \frac{B}{t} - \frac{C}{t^2}$,

where $\log_{10} B = 3\cdot1812$, $\log_{10} C = 5\cdot0882$.

ρ is in pounds per sq. inch, t is absolute temperature Centigrade.

u is the volume in cubic feet per pound of steam.

$\pi = 3\cdot1416$.

1 radian = 57·3°.

To convert common into Napierian logarithms, multiply by 2·3026.

The base of the Napierian logarithms is $e = 2\cdot7183$.

The value of g at London = 32·182 feet per sec. per sec.

	0	1	2	3	4	5	6	7	8	9	1	2	3	4	5	6	7	8	9	
10	0000	0043	0086	0128	0170						4 9 13	17 21 25	30 34 39							
						0212	0253	0294	0334	0374	4 8 12	16 20 24	23 27 37							
11	0414	0453	0492	0531	0569						4 8 12	15 19 23	27 31 35							
						0607	0645	0682	0719	0755	4 7 11	15 19 22	26 30 33							
12	0792	0828	0864	0899	0934						3 7 11	14 18 21	25 28 32							
						1004	1038	1072	1106		3 7 10	14 17 20	24 27 31							
13	1139	1173	1206	1239	1271						3 7 10	13 16 20	23 26 30							
						1303	1335	1367	1399	1430	3 7 10	12 16 19	22 25 29							
14	1461	1492	1523	1553							3 6 9	12 15 18	21 24 28							
					1584	1614	1644	1673	1703	1732	3 6 9	12 15 17	20 23 26							
15	1761	1790	1818	1847	1875	1903					3 6 9	11 14 17	20 23 26							
						1931	1959	1987	2014		3 5 8	11 14 16	19 22 25							
16	2041	2068	2095	2122	2148						3 5 8	11 14 16	19 22 21							
						2175	2201	2227	2253	2279	3 5 8	10 13 15	18 21 23							
17	2304	2330	2355	2380	2405	2430					3 5 8	10 13 15	18 20 23							
						2455	2480	2504	2529		2 5 7	10 12 15	17 19 22							
18	2553	2577	2601	2625	2648						2 5 7	9 12 14	16 19 21							
						2672	2695	2718	2742	2765	2 5 7	9 11 14	16 18 21							
19	2788	2810	2833	2856	2879						2 4 7	9 11 13	16 18 20							
						2900	2923	2945	2967	2989	2 4 6	8 11 13	15 17 19							
20	3010	3032	3054	3075	3096	3118	3139	3160	3181	3201	2 4 6		15 17 19							
						3160	3181	3201	3221	3241	2 4 6	8 10 12	14 16 18							
21	3222	3243	3263	3284	3304	3324	3345	3365	3385	3404	2 4 6	8 10 12	14 15 17							
22	3424	3444	3464	3483	3502	3522	3541	3560	3579	3598	2 4 6	8 10 12	14 15 17							
23	3617	3636	3655	3674	3692	3711	3729	3747	3765	3784	2 4 6	7 9 11								
24	3802	3820	3838	3856	3874	3892	3909	3927	3945	3962	2 4 5	7 9 11	12 14 16							
25	3979	3997	4014	4031	4048	4065	4082	4099	4116	4133	2 3 5	7 9 10	12 14 15							
26	4150	4167	4183	4200	4216	4232	4249	4265	4281	4298	2 3 5	7 8 10	11 13 15							
27	4314	4330	4346	4362	4378	4393	4409	4425	4440	4456	2 3 5	6 8 9	11 13 14							
28	4472	4487	4502	4518	4533	4548	4564	4579	4594	4609	2 3 5	6 8 9	11 12 14							
29	4624	4639	4654	4669	4683	4698	4713	4728	4742	4757	1 3 4	6 7 9	10 12 13							
30	4771	4786	4800	4814	4829	4843	4857	4871	4886	4900	1 3 4	6 7 9	10 11 13							
31	4914	4928	4942	4955	4969	4983	4997	5011	5024	5038	1 3 4	6 7 8	10 11 12							
32	5051	5065	5079	5092	5105	5119	5132	5145	5159	5172	1 3 4	5 7 8	9 11 12							
33	5185	5198	5211	5224	5237	5250	5263	5276	5289	5302	1 3 4	5 6 8	9 10 12							
34	5315	5328	5340	5353	5366	5378	5391	5403	5416	5428	1 3 4	5 6 8	9 10 11							
35	5441	5453	5465	5478	5490	5502	5514	5527	5539	5551	1 2 4	5 6 7	9 10 11							
36	5563	5575	5587	5599	5611	5623	5635	5647	5658	5670	1 2 4	5 6 7	8 10 11							
37	5682	5694	5705	5717	5729	5740	5752	5763	5775	5786	1 2 3	5 6 7	8 9 10							
38	5798	5809	5821	5832	5843	5855	5866	5877	5888	5899	1 2 3	5 6 7	8 9 10							
39	5911	5922	5933	5944	5955	5966	5977	5988	5999	6010	1 2 3	4 5 7	8 9 10							
40	6021	6031	6042	6053	6064	6075	6085	6096	6107	6117	1 2 3	4 5 6	8 9 10							
41	6128	6138	6149	6160	6170	6180	6191	6201	6212	6222	1 2 3	4 5 6	7 8 9							
42	6232	6243	6253	6263	6274	6284	6294	6304	6314	6325	1 2 3	4 5 6	7 8 9							
43	6335	6345	6355	6365	6375	6385	6395	6405	6415	6425	1 2 3	4 5 6	7 8 9							
44	6435	6444	6454	6464	6474	6484	6493	6503	6513	6522	1 2 3	4 5 6	7 8 9							
45	6532	6542	6551	6561	6571	6580	6590	6599	6609	6618	1 2 3	4 5 6	7 8 9							
46	6628	6637	6646	6656	6665	6675	6684	6693	6702	6712	1 2 3	4 5 6	7 7 8							
47	6721	6730	6739	6749	6758	6767	6776	6785	6794	6803	1 2 3	4 5 5	6 7 8							
48	6812	6821	6830	6839	6848	6857	6866	6875	6884	6893	1 2 3	4 4 5	6 7 8							
49	6902	6911	6920	6928	6937	6946	6955	6964	6972	6981	1 2 3	4 4 5	6 7 8							
50	6990	6998	7007	7016	7024	7033	7042	7050	7059	7067	1 2 3	3 4 5	6 7 8							
51	7076	7084	7093	7101	7110	7118	7126	7135	7143	7152	1 2 3	3 4 5	6 7 8							
52	7160	7168	7177	7185	7193	7202	7210	7218	7226	7235	1 2 2	3 4 5	6 7 7							
53	7243	7251	7259	7267	7275	7284	7292	7300	7308	7316	1 2 2	3 4 5	6 6 7							
54	7324	7332	7340	7348	7356	7364	7372	7380	7388	7396	1 2 2	3 4 5	6 6 7							

	0	1	2	3	4	5	6	7	8	9	1 2 3	4 5 6	7 8 9
55	7401	7412	7419	7427	7435	7443	7451	7459	7466	7474	1 2 2	3 4 5	5 6 7
56	7482	7490	7497	7505	7513	7520	7528	7536	7543	7551	1 2 2	3 4 5	5 6 7
57	7559	7566	7574	7582	7589	7597	7604	7612	7619	7627	1 2 2	3 4 5	5 6 7
58	7631	7642	7649	7657	7664	7672	7679	7686	7694	7701	1 1 2	3 4 4	5 6 7
59	7709	7716	7723	7731	7738	7745	7752	7760	7767	7774	1 1 2	3 4 4	5 6 7
60	7782	7789	7796	7803	7810	7818	7825	7832	7839	7846	1 1 2	3 4 4	5 6 6
61	7853	7860	7868	7875	7882	7889	7896	7903	7910	7917	1 1 2	3 4 4	5 6 6
62	7924	7931	7939	7945	7952	7959	7966	7973	7980	7987	1 1 2	3 3 4	5 6 6
63	7993	8000	8007	8014	8021	8028	8036	8041	8048	8055	1 1 2	3 3 4	5 5 6
64	8062	8069	8075	8082	8089	8096	8102	8109	8116	8122	1 1 2	3 3 4	5 5 6
65	8129	8136	8142	8149	8156	8162	8169	8176	8182	8189	1 1 2	3 3 4	5 5 6
66	8195	8202	8209	8215	8222	8228	8235	8241	8248	8254	1 1 2	3 3 4	5 5 6
67	8261	8267	8274	8280	8287	8293	8299	8306	8312	8319	1 1 2	3 3 4	5 5 6
68	8325	8331	8338	8344	8351	8357	8363	8370	8376	8382	1 1 2	3 3 4	4 5 6
69	8388	8395	8401	8407	8414	8420	8426	8432	8439	8445	1 1 2	2 3 4	4 5 6
70	8451	8457	8463	8470	8476	8482	8488	8494	8500	8506	1 1 2	2 3 4	4 5 6
71	8513	8519	8525	8531	8537	8543	8549	8555	8561	8567	1 1 2	2 3 4	4 5 5
72	8573	8579	8585	8591	8597	8603	8609	8615	8621	8627	1 1 2	2 3 4	4 5 5
73	8633	8639	8645	8651	8657	8663	8669	8675	8681	8686	1 1 2	2 3 4	4 5 5
74	8692	8698	8704	8710	8716	8722	8727	8733	8739	8745	1 1 2	2 3 4	4 5 5
75	8751	8756	8762	8768	8774	8779	8785	8791	8797	8802	1 1 2	2 3 3	4 5 5
76	8808	8814	8820	8825	8831	8837	8842	8848	8854	8859	1 1 2	2 3 3	4 5 5
77	8865	8871	8876	8882	8887	8893	8899	8904	8910	8915	1 1 2	2 3 3	4 4 5
78	8921	8927	8932	8938	8943	8949	8954	8960	8965	8971	1 1 2	2 3 3	4 4 5
79	8976	8982	8987	8993	8998	9004	9009	9015	9020	9025	1 1 2	2 3 3	4 4 5
80	9031	9036	9042	9047	9053	9058	9063	9069	9074	9079	1 1 2	2 3 3	4 4 5
81	9085	9090	9096	9101	9106	9112	9117	9122	9128	9133	1 1 2	2 3 3	4 4 5
82	9138	9143	9149	9154	9159	9165	9170	9175	9180	9186	1 1 2	2 3 3	4 4 5
83	9191	9196	9201	9206	9212	9217	9222	9227	9232	9238	1 1 2	2 3 3	4 4 5
84	9243	9248	9253	9258	9263	9269	9274	9279	9284	9289	1 1 2	2 3 3	4 4 5
85	9294	9299	9304	9309	9315	9320	9325	9330	9335	9340	1 1 2	2 3 3	4 4 5
86	9346	9350	9355	9360	9365	9370	9375	9380	9385	9390	1 1 2	2 3 3	4 4 5
87	9395	9400	9405	9410	9415	9420	9425	9430	9435	9440	0 1 1	2 2 3	3 4 4
88	9445	9450	9455	9460	9465	9469	9474	9479	9484	9489	0 1 1	2 2 3	3 4 4
89	9494	9499	9504	9509	9513	9518	9523	9528	9533	9538	0 1 1	2 2 3	3 4 4
90	9542	9547	9552	9557	9562	9566	9571	9576	9581	9586	0 1 1	2 2 3	3 4 4
91	9590	9595	9600	9605	9609	9614	9619	9624	9629	9633	0 1 1	2 2 3	3 4 4
92	9638	9643	9647	9652	9657	9661	9666	9671	9675	9680	0 1 1	2 2 3	3 4 4
93	9685	9689	9694	9699	9703	9708	9713	9717	9722	9727	0 1 1	2 2 3	3 4 4
94	9731	9736	9741	9745	9750	9754	9759	9763	9768	9773	0 1 1	2 2 3	3 4 4
95	9777	9782	9786	9791	9795	9800	9805	9809	9814	9818	0 1 1	2 2 3	3 4 4
96	9823	9827	9832	9836	9841	9845	9850	9854	9859	9863	0 1 1	2 2 3	3 4 4
97	9868	9872	9877	9881	9886	9890	9894	9899	9903	9908	0 1 1	2 2 3	3 4 4
98	9912	9917	9921	9926	9930	9934	9939	9943	9948	9952	0 1 1	2 2 3	3 4 4
99	9956	9961	9965	9969	9974	9978	9983	9987	9991	9996	0 1 1	2 2 3	3 3 4

	0	1	2	3	4	5	6	7	8	9	1 2 3	4 5 6	7 8 9
·00	1000	1002	1005	1007	1009	1012	1014	1016	1019	1021	0 0 1	1 1 1	2 2 2
·01	1023	1026	1028	1030	1033	1035	1038	1040	1042	1045	0 0 1	1 1 1	2 2 2
·02	1047	1050	1052	1054	1057	1059	1062	1064	1067	1069	0 0 1	1 1 1	2 2 2
·03	1072	1074	1076	1079	1081	1084	1086	1089	1091	1094	0 0 1	1 1 1	2 2 2
·04	1096	1099	1102	1104	1107	1109	1112	1114	1117	1119	0 1 1	1 1 2	2 2 2
·05	1122	1125	1127	1130	1132	1135	1138	1140	1143	1146	0 1 1	1 1 2	2 2 2
·06	1148	1151	1153	1156	1159	1161	1164	1167	1169	1172	0 1 1	1 1 2	2 2 2
·07	1175	1178	1180	1183	1186	1189	1191	1194	1197	1199	0 1 1	1 1 2	2 2 2
·08	1202	1205	1208	1211	1213	1216	1219	1222	1225	1227	0 1 1	1 1 2	2 2 3
·09	1230	1233	1236	1239	1242	1245	1247	1250	1253	1256	0 1 1	1 1 2	2 2 3
·10	1259	1262	1265	1268	1271	1274	1276	1279	1282	1285	0 1 1	1 1 2	2 2 3
·11	1288	1291	1294	1297	1300	1303	1306	1309	1312	1315	0 1 1	1 2 2	2 2 3
·12	1318	1321	1324	1327	1330	1334	1337	1340	1343	1346	0 1 1	1 2 2	2 2 3
·13	1349	1352	1355	1358	1361	1365	1368	1371	1374	1377	0 1 1	1 2 2	2 3 3
·14	1380	1384	1387	1390	1393	1396	1400	1403	1406	1409	0 1 1	1 2 2	2 3 3
·15	1413	1416	1419	1422	1426	1429	1432	1435	1439	1442	0 1 1	1 2 2	2 3 3
·16	1445	1449	1452	1455	1459	1462	1466	1469	1472	1476	0 1 1	1 2 2	2 3 3
·17	1479	1483	1486	1489	1493	1496	1500	1503	1507	1510	0 1 1	1 2 2	2 3 3
·18	1514	1517	1521	1524	1528	1531	1535	1538	1542	1545	0 1 1	1 2 2	2 3 3
·19	1549	1552	1556	1560	1563	1567	1570	1574	1578	1581	0 1 1	1 2 2	3 3 3
·20	1585	1589	1592	1596	1600	1603	1607	1611	1614	1618	0 1 1	1 2 2	3 3 3
·21	1622	1626	1629	1633	1637	1641	1644	1648	1652	1656	0 1 1	2 2 2	3 3 3
·22	1660	1663	1667	1671	1675	1679	1683	1687	1690	1694	0 1 1	2 2 2	3 3 3
·23	1698	1702	1706	1710	1714	1718	1722	1726	1730	1734	0 1 1	2 2 2	3 3 4
·24	1738	1742	1746	1750	1754	1758	1762	1766	1770	1774	0 1 1	2 2 2	3 3 4
·25	1778	1782	1786	1791	1795	1799	1803	1807	1811	1816	0 1 1	2 2 2	3 3 4
·26	1820	1824	1828	1832	1837	1841	1845	1849	1854	1858	0 1 1	2 2 3	3 3 4
·27	1862	1866	1871	1875	1879	1884	1888	1892	1897	1901	0 1 1	2 2 3	3 3 4
·28	1905	1910	1914	1919	1923	1928	1932	1936	1941	1945	0 1 1	2 2 3	3 4 4
·29	1950	1954	1959	1963	1968	1972	1977	1982	1986	1991	0 1 1	2 2 3	3 4 4
·30	1995	2000	2004	2009	2014	2018	2023	2028	2032	2037	0 1 1	2 2 3	3 4 4
·31	2042	2046	2051	2056	2061	2065	2070	2075	2080	2084	0 1 1	2 2 3	3 4 4
·32	2089	2094	2099	2104	2109	2113	2118	2123	2128	2133	0 1 1	2 2 3	3 4 4
·33	2138	2143	2148	2153	2158	2163	2168	2173	2178	2183	0 1 1	2 2 3	3 4 4
·34	2188	2193	2198	2203	2208	2213	2218	2223	2228	2234	1 1 2	2 3 3	4 4 5
·35	2239	2244	2249	2254	2259	2265	2270	2275	2280	2286	1 1 2	2 3 3	4 4 5
·36	2291	2296	2301	2307	2312	2317	2323	2328	2333	2339	1 1 2	2 3 3	4 4 5
·37	2344	2350	2355	2360	2366	2371	2377	2382	2388	2393	1 1 2	2 3 3	4 4 5
·38	2399	2404	2410	2415	2421	2427	2432	2438	2443	2449	1 1 2	2 3 3	4 4 5
·39	2455	2460	2466	2472	2477	2483	2489	2495	2500	2506	1 1 2	2 3 3	4 5 5
·40	2512	2518	2523	2529	2535	2541	2547	2553	2559	2564	1 1 2	2 3 4	4 5 5
·41	2570	2576	2582	2588	2594	2600	2606	2612	2618	2624	1 1 2	2 3 4	4 5 5
·42	2630	2636	2642	2649	2655	2661	2667	2673	2679	2685	1 1 2	2 3 4	4 5 6
·43	2692	2698	2704	2710	2716	2723	2729	2735	2742	2748	1 1 2	3 3 4	4 5 6
·44	2754	2761	2767	2773	2780	2786	2793	2799	2805	2812	1 1 2	3 3 4	4 5 6
·45	2818	2825	2831	2838	2844	2851	2858	2864	2871	2877	1 1 2	3 3 4	5 5 6
·46	2884	2891	2897	2904	2911	2917	2924	2931	2938	2944	1 1 2	3 3 4	5 5 6
·47	2951	2958	2965	2972	2979	2985	2992	2999	3006	3013	1 1 2	3 3 4	5 5 6
·48	3020	3027	3034	3041	3048	3055	3062	3069	3076	3083	1 1 2	3 4 4	5 5 6
·49	3090	3097	3105	3112	3119	3126	3133	3141	3148	3155	1 1 2	3 4 4	5 6 6

	0	1	2	3	4	5	6	7	8	9	1 2 3	4 5 6	7 8 9
.50	3162	3170	3177	3184	3192	3199	3206	3214	3221	3228	1 1 2	3 4 4	5 6 7
.51	3236	3243	3251	3258	3266	3273	3281	3289	3296	3304	1 2 2	3 4 6	5 6 7
.52	3311	3319	3327	3334	3342	3350	3357	3365	3373	3381	1 2 2	3 4 5	5 6 7
.53	3388	3396	3404	3412	3420	3428	3436	3443	3451	3459	1 2 2	3 4 5	6 6 7
.54	3467	3475	3483	3491	3499	3508	3516	3524	3532	3540	1 2 2	3 4 5	6 6 7
.55	3548	3556	3565	3573	3581	3589	3597	3606	3614	3622	1 2 2	3 4 5	6 7 7
.56	3631	3639	3648	3656	3664	3673	3681	3690	3698	3707	1 2 3	3 4 5	6 7 8
.57	3716	3724	3733	3741	3750	3758	3767	3776	3784	3793	1 2 3	3 4 5	6 7 8
.58	3802	3811	3819	3828	3837	3846	3855	3864	3873	3882	1 2 3	4 4 5	6 7 8
.59	3890	3899	3908	3917	3926	3936	3945	3954	3963	3972	1 2 3	4 5 5	6 7 8
.60	3981	3990	3999	4009	4018	4027	4036	4046	4055	4064	1 2 3	4 5 6	6 7 8
.61	4074	4083	4093	4102	4111	4121	4130	4140	4150	4159	1 2 3	4 5 6	7 8 9
.62	4169	4178	4188	4198	4207	4217	4227	4236	4246	4256	1 2 3	4 5 6	7 8 9
.63	4266	4276	4285	4295	4305	4315	4325	4335	4345	4355	1 2 3	4 5 6	7 8 9
.64	4365	4375	4385	4395	4406	4416	4426	4436	4446	4457	1 2 3	4 5 6	7 8 9
.65	4467	4477	4487	4498	4508	4519	4529	4539	4550	4560	1 2 3	4 5 6	7 8 9
.66	4571	4581	4592	4603	4613	4624	4634	4645	4656	4667	1 2 3	4 5 6	7 9 10
.67	4677	4688	4699	4710	4721	4732	4742	4753	4764	4775	1 2 3	4 5 7	8 9 10
.68	4786	4797	4808	4819	4831	4842	4853	4864	4875	4887	1 2 3	4 6 7	8 9 10
.69	4898	4909	4920	4932	4943	4955	4966	4977	4989	5000	1 2 3	5 6 7	8 9 10
.70	5012	5023	5035	5047	5058	5070	5082	5093	5105	5117	1 2 4	5 6 7	8 9 11
.71	5129	5140	5152	5164	5176	5188	5200	5212	5224	5236	1 2 4	5 6 7	8 10 11
.72	5248	5260	5272	5284	5297	5309	5321	5333	5346	5358	1 2 4	5 6 7	9 10 11
.73	5370	5383	5395	5408	5420	5433	5445	5458	5470	5483	1 3 4	5 6 8	9 10 11
.74	5495	5508	5521	5534	5546	5559	5572	5585	5598	5610	1 3 4	5 6 8	9 10 12
.75	5623	5636	5649	5662	5675	5689	5702	5715	5728	5741	1 3 4	5 7 8	9 10 12
.76	5754	5768	5781	5794	5808	5821	5834	5848	5861	5875	1 3 4	5 7 8	9 11 12
.77	5888	5902	5916	5929	5943	5957	5970	5984	5998	6012	1 3 4	5 7 8	10 11 12
.78	6026	6039	6053	6067	6081	6095	6109	6124	6138	6152	1 3 4	6 7 8	10 11 13
.79	6166	6180	6194	6209	6223	6237	6252	6266	6281	6295	1 3 4	6 7 9	10 11 13
.80	6310	6324	6339	6353	6368	6383	6397	6412	6427	6442	1 3 4	6 7 9	10 12 13
.81	6457	6471	6486	6501	6516	6531	6546	6561	6577	6592	2 3 5	6 8 9	11 12 14
.82	6607	6622	6637	6653	6668	6683	6699	6714	6730	6745	2 3 5	6 8 9	11 12 14
.83	6761	6776	6792	6808	6823	6839	6855	6871	6887	6902	2 3 5	6 8 9	11 13 14
.84	6918	6934	6950	6966	6982	6998	7015	7031	7047	7063	2 3 5	6 8 10	11 13 15
.85	7079	7096	7112	7129	7145	7161	7178	7194	7211	7228	2 3 5	7 8 10	12 13 15
.86	7244	7261	7278	7295	7311	7328	7345	7362	7379	7396	2 3 5	7 8 10	12 13 15
.87	7413	7430	7447	7464	7483	7499	7516	7534	7551	7568	2 3 5	7 9 10	12 14 16
.88	7586	7603	7621	7639	7656	7674	7691	7709	7727	7745	2 4 5	7 9 11	12 14 16
.89	7762	7780	7798	7816	7834	7852	7870	7889	7907	7925	2 4 5	7 9 11	13 14 16
.90	7943	7962	7980	7999	8017	8035	8054	8072	8091	8110	2 4 6	7 9 11	13 15 17
.91	8128	8147	8166	8185	8204	8222	8241	8260	8279	8299	2 4 6	8 9 11	13 15 17
.92	8318	8337	8356	8375	8395	8414	8433	8453	8472	8492	2 4 6	8 10 12	14 15 17
.93	8511	8531	8551	8570	8590	8610	8630	8650	8670	8690	2 4 6	8 10 12	14 16 18
.94	8710	8730	8750	8770	8790	8810	8831	8851	8872	8892	2 4 6	8 10 12	14 16 18
.95	8913	8933	8954	8974	8995	9016	9036	9057	9078	9099	2 4 6	8 10 12	15 17 19
.96	9120	9141	9162	9183	9204	9226	9247	9268	9290	9311	2 4 6	8 11 13	15 17 19
.97	9333	9354	9376	9397	9419	9441	9462	9484	9506	9528	2 4 7	9 11 13	15 17 20
.98	9550	9572	9594	9616	9638	9661	9683	9705	9727	9750	2 4 7	9 11 13	16 18 20
.99	9772	9795	9817	9840	9863	9886	9908	9931	9954	9977	2 5 7	9 11 14	16 18 20

Mathematical Tables

Degrees.	Radians.	Chord.	Sine.	Tangent.	Cotangent.	Cosine.			
0°	0	0	0	0	∞	1	1·414	1·5708	90°
1	·0175	·017	·0175	·0175	57·2900	·9998	1·402	1·5533	89
2	·0349	·035	·0319	·0319	28·6363	·9994	1·389	1·5359	88
3	·0524	·052	·0523	·0524	19·0811	·9986	1·377	1·5184	87
4	·0698	·070	·0698	·0699	14·3007	·9976	1·364	1·5010	86
5	·0873	·087	·0872	·0875	11·4301	·9962	1·351	1·4835	85
6	·1047	·105	·1045	·1051	9·5144	·9945	1·338	1·4661	84
7	·1222	·122	·1219	·1228	8·1443	·9925	1·325	1·4486	83
8	·1396	·140	·1392	·1405	7·1154	·9903	1·312	1·4312	82
9	·1571	·157	·1564	·1584	6·3138	·9877	1·299	1·4137	81
10	·1745	·174	·1736	·1763	5·6713	·9848	1·286	1·3963	80
11	·1920	·192	·1908	·1914	5·1446	·9816	1·272	1·3789	79
12	·2094	·209	·2079	·2126	4·7046	·9781	1·259	1·3614	78
13	·2269	·226	·2250	·2309	4·3315	·9744	1·245	1·3439	77
14	·2442	·244	·2419	·2493	4·0108	·9703	1·231	1·3265	76
15	·2618	·261	·2588	·2679	3·7321	·9659	1·218	1·3090	75
16	·2794	·278	·2756	·2867	3·4874	·9613	1·204	1·2915	74
17	·2967	·296	·2924	·3057	3·2709	·9563	1·190	1·2741	73
18	·3142	·313	·3090	·3249	3·0777	·9511	1·176	1·2566	72
19	·3316	·330	·3256	·3443	2·9042	·9455	1·161	1·2392	71
20	·3491	·347	·3420	·3640	2·7475	·9397	1·147	1·2217	70
21	·3665	·364	·3581	·3839	2·6051	·9336	1·133	1·2043	69
22	·3840	·382	·3716	·4040	2·4751	·9272	1·118	1·1868	68
23	·4014	·399	·3907	·4245	2·3559	·9205	1·104	1·1694	67
24	·4189	·416	·4067	·4452	2·2460	·9135	1·089	1·1519	66
25	·4363	·433	·4226	·4663	2·1445	·9063	1·075	1·1345	65
26	·4538	·450	·4384	·4877	2·0503	·8988	1·060	1·1170	64
27	·4712	·467	·4540	·5095	1·9626	·8910	1·045	1·0996	63
28	·4887	·484	·4695	·5317	1·8807	·8829	1·030	1·0821	62
29	·5061	·501	·4848	·5543	1·8040	·8746	1·015	1·0647	61
30	·5236	·518	·5000	·5774	1·7321	·8660	1·000	1·0472	60
31	·5411	·531	·5150	·6009	1·6643	·8572	·985	1·0297	59
32	·5585	·551	·5299	·6249	1·6003	·8480	·970	1·0123	58
33	·5760	·568	·5446	·6494	1·5399	·8387	·954	·9948	57
34	·5934	·585	·5592	·6745	1·4826	·8290	·939	·9774	56
35	·6109	·601	·5736	·7002	1·4281	·8192	·923	·9599	55
36	·6283	·618	·5878	·7265	1·3764	·8090	·908	·9425	54
37	·6458	·635	·6018	·7536	1·3270	·7986	·892	·9250	53
38	·6632	·651	·6157	·7813	1·2799	·7880	·877	·9076	52
39	·6807	·668	·6293	·8098	1·2349	·7771	·861	·8901	51
40	·6981	·684	·6428	·8391	1·1918	·7660	·845	·8727	50
41	·7156	·700	·6561	·8693	1·1504	·7547	·829	·8552	49
42	·7330	·717	·6691	·9004	1·1106	·7431	·813	·8378	48
43	·7505	·733	·6820	·9325	1·0724	·7314	·797	·8203	47
44	·7679	·749	·6947	·9657	1·0355	·7193	·781	·8029	46
45	·7854	·765	·7071	1·0000	1·0000	·7071	·765	·7854	45
			Cosine.	Cotangent.	Tangent.	Sine.	Chord.	Radians.	Degrees.

