

UNIVERSAL  
LIBRARY

**OU\_154445**

UNIVERSAL  
LIBRARY





OSMANIA UNIVERSITY LIBRARY

Call No. 604 / RS2P

Accession No. 21872

Author Richardson, E.G.

Title Physical Science in art and industry, 1940

This book should be returned on or before the date last marked below.



**PHYSICAL SCIENCE IN ART  
AND INDUSTRY**



# PHYSICAL SCIENCE IN ART AND INDUSTRY

*By*

**E. G. RICHARDSON**

B.A., Ph.D., D.Sc.



THE ENGLISH UNIVERSITIES PRESS LTD  
LONDON

FIRST PRINTED . . . . . 1940

*Made and Printed in Great Britain by  
Hazell, Watson & Viney Ltd., London and Aylesbury.*

## CONTENTS

CHAPTER	PAGE
I. THE PHYSICS OF LOCOMOTION: VEHICLES . . . . .	1
II. THE PHYSICS OF LOCOMOTION: SHIPS . . . . .	21
III. THE PHYSICS OF LOCOMOTION: AEROPLANES . . . . .	44
IV. COMMUNICATION PHYSICS . . . . .	65
V. PHYSICS AND POTTERY . . . . .	85
VI. PHYSICS AND THE CULINARY ARTS . . . . .	104
VII. PHYSICS ON THE FARM . . . . .	125
VIII. RIVER HYDROLOGY . . . . .	145
IX. PHYSICS DOWN THE MINE . . . . .	167
X. PHYSICS IN FINE ART AND ARCHÆOLOGY . . . . .	183
XI. PHYSICS OF BUILDING MATERIALS . . . . .	202
XII. ARCHITECTURAL PHYSICS . . . . .	221
XIII. SCIENCE AND THE MUSICIAN . . . . .	241
XIV. TEXTILE PHYSICS . . . . .	261
XV. PHYSICS AND THE ART OF WAR . . . . .	279



## PREFACE

ENCOURAGED by the reception accorded to *Physical Science in Modern Life*, I have ventured to inflict on a long-suffering public a second volume on applied physics to show how physics has aided the recent developments in art and industry. While it may be found more serious reading than the first book, it follows on from it, in a sense, and I hope that no one with a stomach robust enough for the first course will experience any discomfort over the somewhat stronger meat in this, the second. While I have not blessed this book with the title of textbook of applied physics, I hope it will appeal to those professional physicists—whether research workers or teachers—to whom the earlier one would appear puerile. It is, indeed, surprising how little the scientific workers in one industry know of what goes on in another; and yet many industries are faced with a number of basic physical problems which are dealt with as they arise by the research personnel. They are often blissfully unconscious of the fact that the same problem has already been fully worked out in another industry and merely demands a little adaptation on their part of authenticated results. Such similarities account for the intrusion of the same piece of research or of apparatus in several of my chapters; such, for instance, as the measurement of particle size, the use of hot-wire detectors and the estimation of colour. These have been described in detail at what seemed the most relevant appropriate place and are elsewhere given a cursory description. Apart from such instances, I have tried to avoid irritating cross-references either to other chapters of the present work or to the preceding one.

Each chapter concludes with a short bibliography of the principal sources from which I have derived my information and a list of prominent journals (in English) in which papers on the physical aspects of the particular art or industry often

appear. A perusal of these will lead the reader to other books, papers, and journals, if he wishes to read further on any particular point. I would also refer him to the general series "Physics in Industry," reports of lectures given before the Institute of Physics in the past two decades.

I wish to proffer my best thanks to those who have helped me by allowing me to reproduce drawings and photographs. Their names are given after the figure captions and in the sources at the end of the chapter. Where no such acknowledgment appears, I must be held responsible for any defects of presentation. Especially do I owe a debt to Messrs. Arnold and the Editors of *Science Progress* for allowing me to quote freely from articles of mine which have appeared therein; and to Dr. H. L. Penman for reading the manuscript and making helpful suggestions, particularly in respect of Chapters VII and XIV.

E. G. RICHARDSON.

## LIST OF ILLUSTRATIONS

FIG.	PAGE
1. Racing Car with Rocket Propulsion . . . . .	11
2. Layout of Curves and Camber for Bend in Road . . . . .	15
3. Streamlined Locomotive (Plate I) . . . . .	20
4. Types of Noise Insulation on Ship Frames . . . . .	31
5. Engine Noise in Cabins before and after Insulation at various Engine Speeds, M.V. <i>Ulster Queen</i> . . . . .	32
6. Echo-sounding Apparatus . . . . .	39
7. Wind Tunnel, Closed Type . . . . .	45
8. Wind Tunnel, Open-jet Type . . . . .	47
9. Lift and Drag for typical Aerofoil, Unslotted and with Slot Open . . . . .	49
10. Contours of Equal Velocity round an Aerofoil at 9.5° Incidence . . . . .	56
11. Lift and Drag Coefficients and Lift/Drag Ratio for a Rotating Cylinder in a Steady Wind . . . . .	60
12. Schneider Trophy Aeroplane (Plate I) . . . . .	20
13. Records of Speech Wave Forms of Vowel <i>a</i> before and after Transmission through Telephone Line with Distortion (Plate II) . . . . .	74
14. Microphone and Cathode-ray Oscillograph Recording Unit for Transmission Characteristics of Systems of Speech Communication (Plate II) . . . . .	74
15. Scales of Loudness . . . . .	77
16. Apparatus for Measurement of Impedance of Ear . . . . .	81
17. Sedimentation of a Poly-disperse System . . . . .	86
18. Photo-electric Particle Size Meter . . . . .	89
19. Coaxial Cylinder Apparatus for Shearing Liquids and Pastes . . . . .	92
20. Torque: Rate of Shear Curves for Pure Liquids and Clay Pastes . . . . .	94
21. Rigidity and Critical Stress of Clay Pastes . . . . .	95
22. Concentric Cylinder Apparatus with Hot-wire Attachment for measuring Velocity Gradients . . . . .	97
23. Velocity Gradients at Various Speeds of Outer Cylinder in Clay Paste . . . . .	98

FIG.	PAGE
24. Apparatus for Recording Extension of Dough . . . . .	106
25. Apparatus for Recording Compression of Dough and Clay . . . . .	107
26. Strain and Relaxation of Plastic Substance . . . . .	108
27. Viscosity of Emulsions; Benzene in Water; Water in Benzene . . . . .	114
28. Disc oscillating in Gelatine Solution during Cooling; showing (a) Time-period of Swing, (b) Temperature, (c) Damping Factor . . . . .	119
29. Change in Deceleration of Disc in Gelatine Solution during Cooling . . . . .	121
30. Mechanical Analysis of Typical Soil . . . . .	126
31. Moisture Meter for Soil . . . . .	135
32. Moisture: Vapour Pressure Curves for Drying and Wetting of Soil . . . . .	137
33. Submerged Orifice Fish Pass (in Section) . . . . .	147
34. Water Channel for Erosion Experiments . . . . .	154
35. Velocities and Silt Concentrations above Bed of Artificial Channel at three different Outflows . . . . .	155
36. Size Distribution of Silt Samples . . . . .	157
37. Light Intensity: Depth Curve and Velocity; Depth Curve in a Natural River . . . . .	158
38. Silt Run-off Meter and Experimental Plots, New Jersey (Plate III) . . . . .	160
39. Check Dams in River to prevent Erosion of Bed, Switzer- land (Plate III) . . . . .	160
40. Photo-electric Relay Circuit . . . . .	168
41. Flicker Warning Device . . . . .	170
42. Echo-prospecting . . . . .	176
43. Seismograph . . . . .	177
44. Diagram of Eötvös Torsion Balance . . . . .	179
45. Results of Magnetic Traverse of a Dike . . . . .	180
46. Schematic Diagram of Lovibond-Schofield Tintometer . . . . .	188
47. Italian Painting under Ordinary Light (Plate IV) . . . . .	193
48. Italian Painting under X-rays (Plate IV) . . . . .	193
49. Pressure required to extrude Plastic at Constant Rate . . . . .	195
50. Use of Seismic Waves in Archæology . . . . .	198
51. Apparatus for Measurement of Compression of Wood parallel to Grain . . . . .	204

## LIST OF ILLUSTRATIONS

xi

FIG.	PAGE
52. Apparatus for Measurement of Sound Absorption of Small Specimens . . . . .	211
53. Acoustical Laboratory; Absorption of Large Specimens (Plate V) . . . . .	236
54. Absorption and Weight Factor . . . . .	218
55. Intensity of Illumination round Lamp with and without Silvered Glass Reflector . . . . .	225
56. Effect of Illumination on Compositors' Output . . . . .	226
57. Rise and Decay of Loudness in an Auditorium . . . . .	230
58. Spark Photography Apparatus . . . . .	235
59. Spark Photograph to illustrate Sound Propagation in Auditorium (Plate V) . . . . .	236
60. Flue Organ Pipe . . . . .	243
61. Reed Organ Pipe . . . . .	244
62. Acoustic Spectra of 'Cello before and after Change in Positions of Bridge and Sound-post . . . . .	250
63. Electrical Production of Tone, Electro-magnetic Type . . . . .	255
64. Electrical Production of Tone, Electrostatic Type . . . . .	256
65. Extension of Cellulose Textiles at various Relative Humidities (R.H.) . . . . .	264
66. Change of Dimensions of Cotton Fibre on Mercerisation . . . . .	265
67. Viscosity and Relative Strength of Two Viscose Solutions . . . . .	268
68. Extension of Wool Fibre at various Relative Humidities compared to that of Silk . . . . .	270
69, 70. X-ray Photographs of Unstretched and Stretched Wool (Plate VI) . . . . .	275
71. Shock Waves from Projectile at Supersonic Speeds . . . . .	283
72. Hot-wire Microphone . . . . .	285
73. Trumpet Sound Locator (Plate VI) . . . . .	275



## CHAPTER I

# THE PHYSICS OF LOCOMOTION: VEHICLES

THE origin of the wheel may be lost in the mists of antiquity, but few would refuse to admit it as one of the landmarks of civilisation. While walking is not the only means of travel without wheels—there are less common ones to be seen on the high Alps, or even in the main street of Devon's Clovelly—yet it would be difficult to imagine our present-day transport unassisted by the wheel. As the lumbering barouche of the sixteenth century gave place to the comparatively swift phaeton of the eighteenth, the necessity for maintained roads made itself felt, and with the satisfaction of that need appeared the first sign of the roadmaker's indifference to natural beauty or antiquity. The construction of a military road out of materials 'won' from the Roman Wall that separates England from Scotland may be cited as an early instance of that vandalism which permitted a later age to construct arterial roads lined with red brick bungalows and garish petrol stations; one of the 'prices of progress' which we are asked to pay—unnecessarily—to-day.

After the coming of the railway there elapsed a long period during which the roads and coaching inns were deserted and the science of roadmaking almost forgotten, until the advent of the bicycle and that of the motor-car which followed it transformed the face of the country. Indeed, the state of the roads had fallen so low in the eighteen-seventies that the then newly-founded Cyclists' Touring Club issued gratuitous pamphlets to the local surveyors on the construction and maintenance of the roads. They even instituted legal proceedings against those authorities who neglected their duties in this respect, though, admittedly, the duties in question had to be carried

out on a county rate which the present-day highway engineer would swallow up in office expenses. Meanwhile, improvements in speed and permanent way had gone on without intermission on the railways except for the period of the European War, so that now, under an all-embracing Ministry of Transport, experience gained on the rails is being applied to the construction of motor roads.

That genie—now benevolent, now malevolent—of friction plays a star rôle in all forms of locomotion. There is a perceptible difference in the tractive effort required to propel a vehicle on a level road with change in the nature of the surface. The general practice up to a year or two ago has been to smooth the road surface, ease the curves and iron out the gradients in undulating country. This has resulted in a progressive increase in average vehicular speeds. Of course, some of this increase of speed is to be put to the credit of the motor-car manufacturer, but there remains a considerable increment of traffic speed outside the towns which is directly due to road improvements. This is shown by the progressive advance in the speed of cyclists riding against the clock since 'time trials' for cyclists were instituted; their vehicle has remained substantially as it was thirty years ago, while the human physique has presumably changed little in the interim. For reasons on which we shall expatiate shortly, the tendency is now a reversion to a somewhat rougher road, so that it seems probable that the limit to engineless speed on the road has now been reached.

The other invention which has revolutionised road transport, and of which the jubilee is being celebrated at the time of writing (1938), is that of the pneumatic tyre. In spite of its undoubted usefulness the air-filled tyre was probably of more service in its early days than now, for its great virtue is the resilience that it shows to shock. A vehicle shod with such a tyre can therefore pass over inequalities in the ground without undue waste of energy. In the year 1887 J. B. Dunlop, a retired veterinary surgeon, put an air tube round a disc of wood, wrapped canvas round the tube and tacked the edges

of the canvas to the wood. This, the first pneumatic tyre, inflated by a football pump, he tested by impelling it along the ground, comparing its progress with that of a solid-tyred wheel taken from his son's toy tricycle. The solid-tyred wheel stopped within a yard, but the pneumatic when started with the same impetus continued the length of the court and rebounded from the door at the far end. Convinced by this experiment that the new tyre required much less tractive effort than the type which was universal at the time, Dunlop proceeded to fit the tyre to bicycles and tricycles. The public were persuaded of the usefulness of the invention when a racing cyclist riding the new pneumatics romped away with a race against solid-tyred competitors at Belfast in 1889. The subsequent history of the pneumatic tyre does not concern us, but we may usefully inquire into the origin of the lessened tractive resistance. A large part of this must be ascribed to the reduction in vibration. When the pneumatic tube is subjected to a blow, the stress is quickly distributed throughout the air sac before the local affected portion has had time to relax, so that the axle of the wheel is raised and lowered but a small amount compared to the depth of the 'pot-hole.' Moreover, it is quite an exceptional jolt which can either raise the tyre out of contact with the ground or make it hit the rim. A vehicle shod with a rigid tyre wastes much energy in this way when passing over a bumpy road. Not only is the engine or human propellant subjected to vibration which lowers its efficiency, but in an extreme case the load on it is ever changing. Apart from this, every miniature hillock on the surface requires work to be done against gravity on the part of the driving force to raise the machine over it, which is never completely regained or stored up in the fall down the ensuing declivity. (Here has been a happy hunting-ground for inventors, who have to their credit several patents for bicycles with spring frames in which the energy stored up on compression is supposed to be made available to help the rider down the other side of the excrescence on the road!)

The resilient properties of the pneumatic tyre are closely

#### 4 PHYSICAL SCIENCE IN ART AND INDUSTRY

allied to that more familiar physical concept of elasticity. In other words, it is the speed with which the tyre can recover from a compression that matters most. On a level road not cut up by pot-holes, the axle of the wheel continues on a level, undisturbed course, the work done, apart from that required to overcome friction in the mechanism, being expended in flattening and reflexing that part of the tread which comes successively in contact with the road. When inequalities are met, a certain amount of 'irreversible work' in changing the pressure of the air in the tube is demanded. The resilience of the tyre, and therefore its efficiency in the engineering sense of the ratio of useful work to the total expenditure, depends on the speed with which the processes of reflexing and restoration of normal working pressure take place, and this in turn depends on the quality of the rubber and width of its tread on the one hand and on the resistance offered by the surface on the other. During the recovery, the tyre must have something hard to push against. The two desiderata of easy riding over the bumps and good speed are here antagonistic. The rider or driver who wants an easy passage over rough and soft roads fits wide low-pressure or 'balloon' tyres. The racing cyclist on a hard cement track fits high-pressure tyres with a tread which leaves little more than a pencil line on the track where it has passed over it. Again, roadster tyres are heavily rubbered on the sides to secure freedom from punctures though at the expense of resilience, while track-racing tyres have thin canvas sides and a bare half-inch width of rubber on the tread. (Incidentally, wheel diameter also affects the proneness to vibration, as the reader may deduce for himself by applying elementary mechanical principles.)

From these aspects it might be thought that on a hard track a very rigid tyre would be preferable to the pneumatic tyre. We do in fact find these very conditions on the railroad and tram track, but this does not free the locomotive or tram from outlay of effort on the level. The track gives under the weight transmitted through the axles to that part of the rim in

momentary contact with the rails, so that the leading wheels are constantly being driven up a little gradient which the machine makes in its course in the erstwhile level track. Alternatively, one may think of the work of propulsion as being expended in depressing and raising the 'road' into its foundations of ballast as the train passes. The road on a main line is in fact far from inflexible at the present time as it is found that excessive rigidity results in vibration at high speeds. So, by elaborate cushioning on ballast, the rails are permitted to give at the passage of the train.

Friction finds its useful sphere in the acceleration and braking of vehicles. Consider a train starting on the level from a station. The tractive effort is exerted through the circumference of the driving-wheels against the rails. As long as this action is balanced by an equal reaction on the part of the rail, its leverage can turn the wheel against the point of contact acting as a temporary fulcrum and drive the locomotive forward. There is however a limit to the reaction which the rail can proffer, dependent on the grip between wheel and rail. If this be exceeded the surplus of effort transmitted to the rim of the wheel is available for driving the point of contact of the rim backwards relative to the rail, and slipping occurs. This is aggravated by the fact that once slip has started, the friction preventing relative motion drops to a value less than that which obtained just before slipping commenced. The frictional resistance is thus further reduced and the wheel gathers speed in skimming over the rail without propelling the train forward. The driver's remedy for this state of affairs is to shut off steam and re-open the regulator more gently after the driving wheels have stopped spinning and have regained their grip. The re-establishment of contact can be hastened—at the same time that it allows of somewhat more rapid acceleration without slip—if a blast of sand be directed between wheel and rail. On the other hand, any condition which lessens the coefficient of friction between wheel and rail will naturally exaggerate the tendency to slip. A thin film of water after a light 'dagging' rain or, worse still,

a layer of oil on the track may reduce the frictional reaction to such a value that the locomotive lacks the adhesion necessary to propel the train. An accident on a British railway in the last century was attributed to the passage of a train of leaky fish wagons on an upgrade having so lubricated the rails that a following passenger train was unable to make the grade but, with brakes hard on, slid backwards and collided with another train halted at the preceding station.

It therefore becomes evident that to increase the power of the engine propelling a vehicle is useless unless at the same time due consideration is given to the provision of sufficient adhesion to road or track on the part of the wheels through which the propulsive force is exerted. To a certain extent this condition is automatically looked after by the fact that the frictional force is directly proportional to the load on the axles and that in putting in a more powerful engine you usually, *ipso facto*, increase the load. If, however, the weight of an engine increased also in direct proportion to its power, there would be little advantage in building more powerful locomotives, for then, on a gradient, there would be little reserve for load haulage or speed. If the load is distributed over a number of axles, as it invariably is, the question arises whether it is best to have the drive working through one axle only or shared by a number of pairs of coupled wheels. On locomotives and heavy lorries the latter is the common practice; the engine driving through coupling rods or gearing to two or more axles. This has a considerable advantage in preventing slipping or skidding of the wheels, because the ease with which a wheel will accelerate its rate of rotation is inversely proportional to its inertia in respect of rotary forces. Thus a large and heavy rimmed wheel is less easily set spinning than a light one of small diameter. The former is therefore less likely to slip when the driver opens the throttle than the latter. When two or more wheels are coupled their respective inertias must be added. With the light loads which constituted the usual express trains up to the beginning of the present century, single driving wheels of seven to nine feet in

diameter were the practice on two important main lines in this country. They had the disadvantage that, like a high-geared bicycle, they were difficult to start but, once under way, speeds of sixty or seventy miles an hour were easily maintained on the level. With the introduction of heavier and longer coaches, this practice had to be abandoned in favour of smaller driving wheels, two or three pairs coupled. The resistance to slip is maintained since one wheel cannot slide without its fellows and the drive is distributed over several points of contact with the rail, but easier acceleration is afforded since the locomotive is geared with a wheel of five or six instead of nine feet. Goods locomotives have still smaller wheels, eight or ten coupled, to enable them to get away with their heavier loads.

The reader does not need to be told that all motor-cars and some bicycles are fitted with change-speed devices. That is to say, that by suitable gearing the motor or human engine has the choice of a number of (effective) wheel diameters through which to transmit the effort to the road. This is because these two types of engine work most efficiently at one set speed. When the machine comes to a hill, if there are a sufficient number of gears available, the machine can maintain its rate of revolution, but in virtue of a lower gear the rate of progress up the hill is less than it was on the level. With the infinitely variable gear, such as has been tried on certain automobiles, this inexorable engine speed will always be permissible, but the greatest number of gears that we have encountered on a bicycle is eight! It may be interesting at this point to discuss the question of what horse-power the human being can attain. By estimating the power expended by a racing cyclist in a hill climb, Mr. A. C. Davison estimates that a strong cyclist can exert from one-half to five-eighths of a horse-power for the two or three minutes required to climb a typical steep bank. (One horse-power is equivalent to lifting one pound vertically through 33,000 ft. every minute.) The work done in the vertical displacement of man and machine is, of course, easy to work out; the work against frictional and

wind resistance on the level which has to be added to this is a little more problematical, but is estimated at about one-sixteenth of a horse-power at ten miles per hour. On the modern cycle, adhesion should be greater in climbing a steep hill than on the level since the weight is thrown further back on to the driver. In the days of the large ungeared wheel which was the driving wheel of the 'ordinary' bicycle, the reverse was the case.

On the railway variable gearing is unnecessary. Both the steam engine and the electric motor can take steam from the boiler or current from the mains respectively up to the limit of their resources and still work efficiently. Again, for steep hills the rolling wheel may provide inadequate adhesion. Then a rack rail must be provided with which the engine engages through a cog wheel.

In order to secure the adhesion of motor-car wheels to the road special devices, other than corrugated treads to the tyres to reduce the danger of skidding, are not common, as the dead weight is usually sufficient for the purpose. Exceptionally large racing motor-cars are provided with inverted aerofoils projecting from each side of the chassis. They are inverted in the sense that the convex surface of the aerofoil is below instead of on top, as in the aeroplane wing. (One such can be seen in Fig. 1.) As the car is driven along, the force of the wind acting on these wings produces a component directed downwards and so holds the car on the ground against its tendency to leap at high speeds over inequalities in the track. Of course, the resistance of these aerofoils also has a component directed against the line of propulsion, which has to be overcome by the expenditure of some energy on the part of the motor, but this resistance may be kept within bounds by choosing an aerofoil with a high lift/drag ratio and setting it at such an angle of incidence that this ratio is a maximum for the aerofoil in question. A further advantage to be found in this method of securing the grip between the tyres and the road is that the force of depression increases as the square of the speed of the vehicle. It is, in fact, an expedient scarcely worth while below motor-racing speeds.

Of course, there yet remain other ways of dodging the adhesion bogey of a more direct type, in which the vehicle is not driven through the wheels. Although a number of devices of a rather freakish nature falling within this category have been tried at various times none of them has reached the stage of commercial adoption. One of these—the ‘atmospheric railway’—dates from the earliest days of railway history. This contrivance required the laying down of an airtight tube in the centre of the ‘four-foot way’ into which compressed air was pumped from a stationary engine at one terminus. There were no locomotives, but one wagon or coach of each train had a bar projecting beneath it, passing into the air conduit through a sleeve valve at the top and terminating in a well-fitting piston. Condensation of the air into the tube had the effect of driving the train away from the pumping station; a rarefaction drew it back. An atmospheric line was opened between London and Croydon in 1845 and in fact relics of it can be in parts traced alongside the present main London and Brighton line. But it was short-lived. While the theory was quite sound, a practicable valve several miles long to open at the passage of the train and close neatly behind it was not. Mayhap the inventor in this age of rubber would have made a better job of it, but the leather valves required constant greasing and were seriously affected by rain, so that very soon leaks developed faster than the repair gang could stop them, and the scheme had to be abandoned. Another idea of that era, based on the same principles, involved placing the whole train in the atmospheric conduit with a piston at one end big enough to fill the whole tube. This might have been feasible on a tube railway without intermediate stations, such as those in capital cities which replace the ferry crossings of rivers, but was, in fact, never carried out. The idea survives in the pneumatic tubes conveying bills and cash in department stores and on a larger scale in the parcels pneumatic tube which connects the General Post Office in London with the distributing office at Mount Pleasant.

The Kearney Tube is another form of tube railway which,

while it does not rely on unorthodox means of propulsion, aims at reducing the energy losses in rolling friction by using a mono-rail. Actually there are two rails in the tube, but the second one is overhead instead of in the conventional position and the vehicles only engage it when at rest. At speed they remain upright under the action of revolving gyroscopes and make contact with the foundations through the lower rail only. It is too early to say what saving in running costs and wear will follow the use of this system, but at the time of writing a Kearney Tube is projected to connect North and South Shields beneath the River Tyne.

For motor-cars, designed to 'cruise' at a high speed, there remain the possibilities of adapting one or other of the types of propeller used on aircraft. The conventional propeller of an aeroplane—the airscrew—cannot work efficiently except when it is advancing at a considerable velocity through the air. An airscrew on a stationary machine expends most of its effort in swirling the air round in a huge vortex, at least in the early stages of its action before it has set up a good draught past itself. So the airscrew is not a good type of propeller for a vehicle which has frequently to start and stop. Nevertheless, experimental cars with large aeroplane propellers mounted above them have been built by optimistic inventors, which were driven over the ground in the same fashion that an aeroplane 'taxies' at taking-off and landing. Another source of loss of efficiency is the 'interference' which the ground offers to the action of the airscrew, which requires to be free to exercise its action on the air without having to overcome the additional burden of dragging the air along the ground against frictional resistance. That is the reason why the propeller is placed high above the chassis of such 'terraplanes' and this again makes the craft awkward to steer. The other type—the reaction or jet propeller—has aroused more interest since the development of liquid fuel has indicated the possibility of the continuous firing of a batch of ignited jets. At the beginning of the present century the Peruvian Paulet constructed a rocket with a conical hull of vanadium steel which

## THE PHYSICS OF LOCOMOTION: VEHICLES II

had two conduits closed by valves containing benzene and nitrogen peroxide respectively. Portions of these reagents were allowed to mix and then ignited by an electric spark. The rocket was not allowed to escape, but the propulsive force was measured and found to exceed by far the power attainable from a rocket filled with gunpowder. It is reckoned that rockets equipped with properly designed combustion chambers and fed with liquid fuel burning at a suitable rate could attain a jet velocity of 4,000 metres per second. The first to drive a car by gas-jet reaction was an Austrian, Max Valier, but in the subsequent experiments he lost his life by the premature

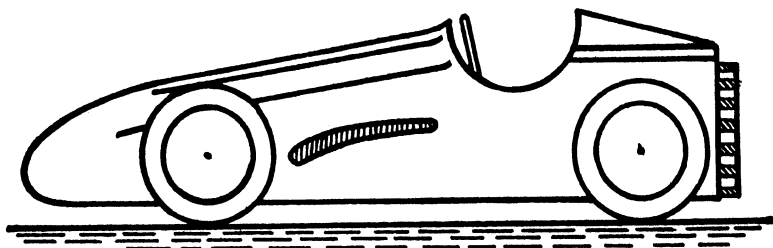

FIG. 1.—RACING CAR WITH ROCKET PROPULSION

explosion of a rocket. A previous attempt to drive a boat on the Seine by rocket in 1886 led to the death of another inventor at the first trial. Valier was able to interest Fritz von Opel, head of the famous German motor firm, in his project, and together with the pyrotechnician Sander they ran the first rocket car at Rüsselsheim in 1928. This was an ordinary motor-car with a couple of powder rockets attached to the back. At the first attempt from a standing start they attained a speed of three miles an hour and the rockets were spent in half a minute. The second time the car was first run up to twenty miles per hour under its own motor, from which it reached forty-five miles per hour in one and a half seconds, an acceleration equal to half that of gravity. (This aptly brings out the point about these propellers, that they are more powerful at high rates of travel.) After this, three special rocket cars were built (Fig. 1) with wings to keep the front

wheel from leaping at speed. The twenty-four rockets were arranged in racks behind the driver, who in addition to using the steering wheel had a control to let off the rockets in turn, corresponding to the accelerator of a conventional motor-car. On the Avus racing track at Berlin a speed of one hundred and twenty miles an hour was reached in one of these, but the experiments appear to have been dropped after the death of Valier, though one occasionally hears of rocket cars being built in America.

In discussing the advantages of jet propulsion as compared with the internal combustion engine, the essential difference between their functions must be appreciated. The work done by the former is calculated in terms of the product: gas pressure times piston stroke; for the latter the criterion is the product: mass of gas expelled per second times velocity of gas. As soon as the relative velocity of rocket and jet changes, as it does when the car goes faster or more slowly, the rate of working changes in the same sense. One cannot then specify the horse-power of a vehicle with a reaction motor, since it is a function of the speed. Again, as an internal combustion engine gains speed, the propulsive force falls until a balance between it and the resistance is struck. As a rocket car using fuel at a constant rate accelerates, the instantaneous value of the horse-power grows with the translatory velocity while the propulsive effort remains constant. The former is therefore suited to traction at a moderate speed but with quick acceleration up to the cruising speed; the latter to the maintenance of a high speed but not to rapid acceleration from rest.

Much has been done both on rail and road in the past decade to improve the comfort of travellers. The loosely bound roads of macadam in the era before the introduction of asphalt and bitumen covering required a steep camber at either side in order to let the water drain off after a shower and to prevent the formation of too frequent puddles. The rain carried with it the loose top-dressing to the edges of the road, so that the chief employment of the road-mender was to carry dislodged debris from the verges to fill up the pot-holes in the centre of the road

in the hope that traffic would consolidate it. The excessive camber caused horse-drawn vehicles to hug the centre of the road and in extreme cases of lack of attention to the surface made one or two pairs of deep ruts which acted like grooved rails for vehicles. Moreover, the chosen camber was invariable, whether the road ran straight or curved; not that this mattered very much when speeds were low. Bends were often very sudden, S bends being common, since the roads were originally boundary tracks between fields, and where these belonged to different farmers they were not aligned. (Exception must be made of roads built over those left by the Romans, which were invariably forthright from Camp to Camp unless their line intersected a steep hill.)

The necessity for inclining the road towards the inside of a curve was first recognised by railway engineers. The 'super-elevation' of the outer rail on a curve is now a recognised practice. It arises from the necessity for providing a component of the reaction which the rails exercise on the train to counteract the centrifugal force on the vehicles which comes into play when they pursue a curved trajectory. This centrifugal force is in this case horizontal, directly proportional to the square of the velocity and inversely as the radius of the curve. It is consequently the high-speed vehicle moving round a sharp curve which requires to lean most towards the centre of the curve and which must be provided with a steeply banked track. Cycle and motor racing tracks exhibit this banking on curves clearly. On the former the angle of bank is about thirty degrees but on the latter banks of twice this angle are not uncommon. The same applies to indoor cycle tracks where the steepness is necessitated by the small curvature of the track rather than by abnormal speed. In virtue of the rigid law connecting velocity, radius of curvature and angle of bank, such a track is really suited to one speed only; speeds in excess or defect of this critical speed give rise to a tendency on the part of the vehicle to slither up or down the bank respectively. It is therefore a common practice to increase the angle of bank of a cement track in saucer fashion from

the inside to the outer rim. A slow-moving vehicle will then be running near the inside while the faster ones can career round the outside of the bowl. In cycle racing in relays or with pacers, it permits those machines which are 'resting' to circulate slowly on the inner flat portion of the track until wanted. On a railway track an allowance for variable speed of this kind cannot be made, but the speed at which the curve should be taken is published to the driver. To prevent excessive speed round a curve derailing a train—due to the centrifugal force being possibly much in excess of the component of reaction supplied by the obliquity—check rails are provided running just inside the inner rail to take the outward pressure of the flanges, if any, which accompanies the centrifugal force. Too slow a passage round the curve is not so dangerous but is often made manifest to the passengers by the noise of grinding of the flanges against the rails.

The shock to the passengers and vehicles which accompanies the entry to and exit from a banked curve at speed due to the sudden change of direction and inclination of the vehicle has led to the design of transition curves on modern roads (whether of cement or of iron) on which the canting can be graduated and the wheels be gradually set on the arc proper till the road is ready to take up a fresh straight course. The favourite entry curve of the modern surveyor is part of the 'lemniscate' of Bernoulli (a curve shaped somewhat like one side of a laurel leaf) which has no curvature at the base—in other words it is straight there—but whose curvature increases at a rate proportional to its distance from this point, until it grows to the value required on the arc proper, where, of course, being part of a circle it retains a constant curvature until it is necessary to commence the exit curve, which is another portion of the same lemniscate. Over the transition curves the outer edge is continually rising, while the inner edge falls correspondingly. A layout for a right-angled bend is shown in Fig. 2.

If a junction occurs on a curve, the correct canting may have to be abandoned partially for both routes or completely for the less important track, while the main line is allowed to

retain its correct banking, it being assumed that the vehicle or train on the branch road will slow down for the junction.

On a curved road the camber is discarded as far as the outer section is concerned and the road made to slope constantly

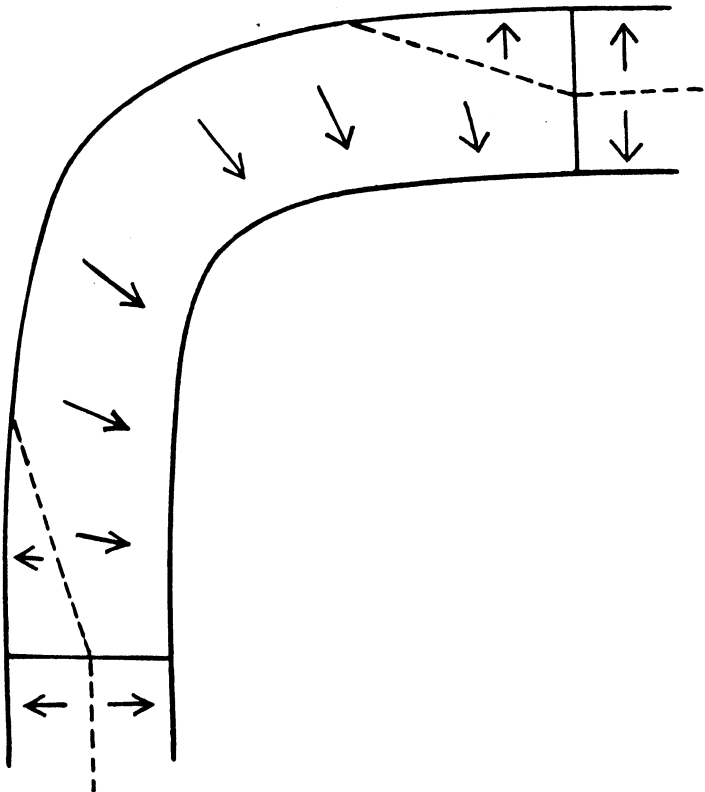

FIG. 2.—LAYOUT OF CURVES AND CAMBER FOR BEND IN ROAD; CENTRE-LINE OF CAMBER SHOWN AS BROKEN LINE

towards the inner edge, so that traffic on this portion must suffer a reversal from an outward to an inward cant and back again when it enters the following straight. It is also customary to allow a greater width to an arterial road on a curve to give long vehicles room to swing round without taking more than their share of the road width.

A number of improvements in the running of express trains are now being introduced in the interests of efficiency and the comfort of the passengers. The first of these concerns reductions in the tendency to roll and execute fore-and-aft oscillation. A certain amount of the former is bound to occur as the train passes over curves, but some damping of the lateral motion can be assured by attention to the wheel flanges. On the invention of the tramway—horse-drawn, of course—in the seventeenth century, the wheels were given deep flanges and virtually ran in grooves. It was soon found that wear was less if the rim of the wheel ran on the top of the rail and the flange used merely as a guide to prevent derailment. This was the form of rail which became standard on the steam railway from its inception (in spite of the misapprehension of the young poet Tennyson who in his inaugural poem on the occasion of the opening of the Manchester and Liverpool Railway implied that the trains ran in grooves!). To aid the train to keep to the track, the wheel rims were made conical, that is to say, the diameter was somewhat less on the outside than on the inside where it met the flange, the top of the rail being likewise sloped inwards to correspond. Recent experiments have shown, however, that a cylindrical rim, i.e. one having the same diameter overall, gives a more regular motion to the vehicle, and the wagon builders favour a coning of only one in a hundred, which is practically flat.

Early in the history of the railway carriage it was found that the bogie provided a means of traversing curves and inequalities of the track with less jolting than wheels running in axle boxes fixed to the frames. If, for instance, one wheel is lowered suddenly by an inch in passing over points, while the others retain, for the moment, their level course, the jolt communicated to the coach through the bogie pin is only one-quarter of an inch as against half an inch if the wheel is on a separate axle. They are worth while even for short coaches, and the practice then is to provide three bogies to a pair of coaches, one end of each being supported on the central bogie, which in this wise articulates the pair of vehicles. A

bogie does, however, tend to 'hunt' from side to side if it is too well sprung, but hunting is also reduced by the use of cylindrical wheels, possibly because a coned wheel will run up and down the rail a little as it proceeds. It is also found that the running on curves is improved if each wheel is capable of independent rotation on the axle. This independence of movement of two wheels on the same axle is, of course, an absolute necessity on vehicles capable of taking sharp turns, and is used in the form of a differential gear on tricycles and motor-cars, though occasionally one of the driving wheels may be fixed on the axle while the other rotates idly at the other end. The function of the leading bogie on express locomotives is to ease the machine round curves and reduce wear on the rims of the leading drivers.

The buffers between coaches should communicate without jolting the forward pull of the locomotive to the rest of the train. If the couplings are too slack, there will be a fore-and-aft surging of the carriages during acceleration, which reaches the extreme case of the longitudinal wave transmitted in shunting to a train of loose-coupled goods wagons. To measure the pull exerted on a train by a locomotive during its trials, a dynamometer may be attached between it and the first coach. Virtually this device consists of a style attached to the coupling spring which writes upon a rotating drum of paper anchored in the coach, and, in so doing records the contractions and extensions communicated to the spring during the run.

Other instruments record the vibrations of higher frequency experienced by the coaches in running over points and the joints between rail sections. Improvements in the axle springing may be noted in this way. (Incidentally, the rail joints are responsible for the major portion of the noise on tube railways, and to reduce this, sections 180 ft. long and welded in one piece are now being tried. The equable temperature which is maintained underground makes it unnecessary to allow for expansion to the extent that is necessary on surface railways.) To damp out such vibrations, the axles

are carried partly on laminated cantilever springs and partly on spiral springs into which the ends of the former are stepped. The axle-box itself runs in guides, as it is attached to the centre of the arc of the laminated spring.

The subject of the insulation of noise will be more fully discussed in the succeeding chapters.

Another subject, consideration of whose niceties must be deferred to a later chapter, is the measurement of wind resistance. We can, however, usefully describe the general considerations which govern the subject of streamlining here and now in so far as they concern trains and motor-cars. Streamlined trains are now common on British railways, though inasmuch as British locomotive practice has never favoured the multitude of 'gadgets' which seem to hang on to every available part of the body of Continental and American locomotives, the reduction in wind resistance achieved by such designs is not so striking. The principles which govern the streamlining of engines and cars are delightfully simple; one simply has to avoid all bluff curves and protuberances, particularly at the front and rear, while the gaps between coaches must be filled up with flexible or jointed screens. It is merely a question of how much of the driver's freedom to get quickly at the vital parts and the induced draught through the fire-box initiated by the free passage of the air over the smokestack are to be sacrificed to secure low resistance. It is interesting, in this connection, to recall that the modern stumpy chimney did not evolve from this aspect, but because the top of the boiler gradually rose to meet it! Though streamlining may reduce the fire draught a little, it usually improves the crew's view of the track ahead because it induces less turbulence in the flow of the smoke over and about the boiler; a not unimportant aspect of the problem.

Pioneer work was carried out on the resistance of a locomotive by the Canadian National Research Council in their laboratories a few years ago. A scale model of a C.N.R. express standing on a model 'ground' was suspended by a system of cords in a horizontal position like the seat of a swing

and a powerful draught blown upon it. The force of the wind pushed the model back and at the same time lifted it a little as when one pushes on a person in a swing. The extent to which the model swayed back was a measure of the force of the wind on it, i.e. of its resistance at that particular relative speed of locomotive and air. The shape of the model was then improved by putting a cowling over the domes, the cowling extended to cover the tender, and metal curtains placed over the wheels and reversing gear until only the smokestack and the bell stood out from the rest (Fig. 3, Plate I). The cow-catcher which prairie locomotives carry was also brought into the streamlining of the front of the machine. The importance of this work is brought out by the estimate that at sixty miles per hour on the level a train of ten coaches requires four hundred horse-power (one-quarter of the total) to be used in overcoming wind resistance. Of this the locomotive contributes about thirty per cent., the last coach ten, and the remainder about seven.

The motor-car manufacturers are not oblivious to the importance of streamlining, and a marked improvement has taken place in the past decade. The general layout of the present-day car limits the improvement that can be made in two respects: it usually has the engine in front, and the draught created by the car is used to help cool the engine. The wind-screen must be vertical so there ensues a marked discontinuity in contour where the engine joins the coach portion. With an engine at the rear a much better shape is possible, but the ideal car should resemble a section of an aeroplane wing as closely as possible.

#### SOURCES

- "Dunlop Jubilee Volume," 1938.  
 Anon.: "Research and the Amenities of Railway Travel" (Nature, **142**, 218, 1938).  
 H. E. Goldsmith: "Road Engineering," 1925.  
 J. J. Green: "Resistance of Locomotives" (Canadian J. Research, **8**, 27, 1933).

20 PHYSICAL SCIENCE IN ART AND INDUSTRY

- R. H. Heald: "Resistance of Automobiles" (Bur. Standards J. Research, **11**, 285, 1933).  
C. G. Jackson: "From Track to Highway," 1933.  
B. H. Knight: "Modern Road Construction," 1938.  
J. T. Lightwood: "Evolution of the Bicycle," 1938.  
C. F. D. Marshall: "Resistance of Express Trains," 1925.  
E. G. Richardson: "The Streamlined Locomotive" (Railway Mag., **75**, 85, 1934).

JOURNALS

Railway Magazine; Trans. Inst. Civil Engineers; Repts. Road Research Board.

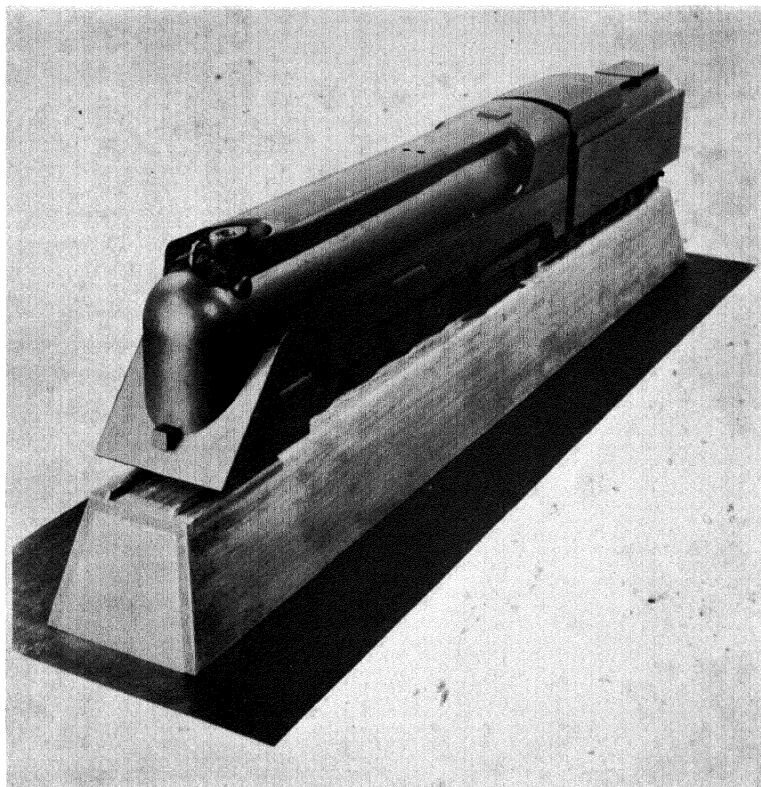

FIG. 3.—STREAMLINED LOCOMOTIVE (*Canadian National Railway*)

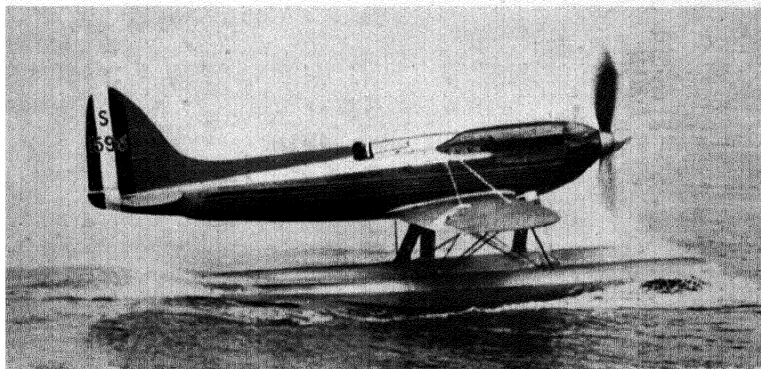

FIG. 12.—SCHNEIDER TROPHY AEROPLANE (*Royal Aeronautical Society*)



THE PHYSICS OF LOCOMOTION:  
SHIPS

LOCOMOTION on and in the sea takes more varied forms than it does on land and more energy must be expended to propel a ship at speeds comparable with those of a motor-car or railway train—making exceptions of the hydroplane and speed-boat, which merely skim the surface of the water and whose mode of motion is rather like that of the aeroplane.

Though the science of rowing has been carefully studied in both its physical and biological aspects, it cannot be said to be an efficient method of propelling a boat. Much water slips past the blade of the oar to form a local turbulent wake. The paddle wheel actually works on the same principle, though it converts the reciprocating action of the skuller into a more efficient—from the engineering point of view—rotary one and lacks the advantage of 'feathering' on the returning blade, which reduces to a considerable extent the resistance on the blade in its motion through the air. At the low speeds common to this form of propulsion, however, this wind resistance is but a small proportion of the total force to be overcome. The sailing vessel in a simple square rig with one sail square-on to the wind employed by primitive peoples is not much better, but in racing cutters the propulsion reaches a high degree of efficiency, mainly on account of a well-groomed hull and the practice of sailing close to the wind. Under the latter conditions, given enough wind to belly the canvas out into a moderate concave tautness, the horizontal section of the sail approaches that of a thin aerofoil set at a small angle of incidence to the wind, save that the surface in the case of the sail has the same curvature on both sides. In spite of this equality of curvature there remains sufficient difference in air velocity on

the two sides to give rise to a *cross force* which replaces the *lift* on the aerofoil and drives the yacht along without the waste of overmuch energy in turbulence. If the vessel is driving before the wind, the sail and tiller may be so set that this cross force moves it continuously along the set course, but should the wind blow dead on, tacking across the course becomes necessary. At the end of each tack the sail-aerofoil is turned over, by the help of the tiller and the wind, which now fills the other side. During this change-over or 'jib' a-certain amount of way is lost, which makes the sailing vessel unsuited for locomotion when speed or reliability is the main object.

A few years ago a new idea in sailing vessels was put out by a German inventor, Herr Flettner, employing vertical rotating cylinders to initiate the necessary cross force from the wind. When a steady wind strikes a *stationary* cylinder in a direction perpendicular to the axis, the resisting force is of course directed in a line exactly contrary to the wind, but when the cylinder is rotated an additional component comes into being directed at right angles to the wind. Under favourable conditions this cross force may amount to six times the *drag*, i.e. the component in the line of the wind. A vertical cylinder erected on the deck and capable of rotation by engines in the hold can therefore act as a sail in the sense that the vessel can be tacked into the wind, and that with more facility than the real sail, since the cylinder, force for force, presents a much smaller surface to the wind than a sheet of canvas and is consequently easier to manœuvre. Actually the rotor ship has two cylinders capable of being turned either in the same or opposite directions. When the latter conditions are operative, the ship of course can be swung round as the cross forces on the cylinders point opposite ways. A vessel constructed on these lines actually sailed from Hamburg to the Wear and back in 1924 but apparently did not justify the expected superiority—in the economic sense—over a sailing ship (requiring no fuel) or a screw ship (requiring an equal amount of fuel), though it was said to be superior to both in respect of ease of navigation.

It should be added that the experimental rotor ship carried an auxiliary propeller of the conventional type, as the inventor was not taking a chance of being becalmed without means of locomotion!

Yet another outlandish type of propulsion was adopted by Barnaby in the 'eighties for two experimental ships built for the British Navy. These employed the same principle as that used by the rocket, viz. the reaction of a jet. From the stern of the vessels, above the water-line, jets of steam were impelled towards the rear, giving them the appearance and sound of monster ginger beer bottles, so much so that this novel method of propulsion was too much for the dignity of the Service and they were broken up. They were followed by others on the same principle, but of different design, in which water was taken up by a scoop in the bows—somewhat in the fashion that a locomotive takes up water from a trough between the rails—and passed through a tube, inside which an ordinary screw propeller accelerated the water and drove it out towards the stern but beneath the water-line. Both types were intended for service in weed-infested rivers, but, we believe, the latter were also given up because of the impossibility of preventing weeds fouling the entry, in spite of grids placed in the scoop, so that their usefulness rapidly deteriorated in service. It is interesting that, in the two designs, jet propulsions both above and below the water were found equally efficacious in spite of the fact that the one jet was working into air while the other was working into a much heavier medium, water. This illustrates the point we have stressed elsewhere, that the jet propeller functions in virtue of the reaction on the vessel which, by Newton's third law of motion, balances the action exerted by the jet, and not—as some would put it—by pressing on the air or water that it strikes in its path. You do not get more reaction with the under-water jet, because the more dense water resists the action more than does the air.

Coming at length to the screw propeller which is found on the vast majority of craft to-day, we observe first that the modern propeller has developed out of the rotating pair of flat

inclined blades, which windmill-like constitute the archetype of this apparatus, into a carefully graded screw having the following characteristics:

(a) Blades of aerofoil section, instead of spar section.

(b) Section graduated from boss to blade tip, both in respect of size of section and angle of incidence, though the section remains similar throughout except near the boss and the tip.

The object of this highly specialised and carefully calculated form is that each part of the blade shall fulfil its purpose, which is to provide adequate thrust and to enable neighbouring portions to exert their share of the thrust without mutual interference. The force on an aerofoil section moving through air or water is usually divided into two rectangular components, one in the direction of the relative wind and the other perpendicular to this direction, and producing the lift. When the aerofoil forms a section of a propeller, these two components participate respectively in the forward thrust and the torque about the axis. The former drives the vessel forward while the latter balances the turning effect of the engine working through the shaft.

As the vessel travels the blade tips trace out spiral paths usually made apparent in the water by the stream of air bubbles which they drive out of the water as they thrash their way through it. To a certain extent each blade disturbs the medium through which its fellows have to pass and reduces the thrust which they could exert if they were isolated aerofoils. This limits the number of blades which can usefully be given to a propeller. In fact, three is the limit for ships and four for aircraft, though two are more common on aeroplanes. There is a story current among propeller designers of a vessel provided by its makers with a four-bladed screw which had one accidentally knocked off in berthing and thereafter travelled at a superior speed with less expenditure of fuel.

One source of wear and tear in ships' propellers which does not afflict the airscrew is corrosion, caused partly by chemical action in salt water and partly through purely physical wear

under the continuous series of shocks which are given and received as the blades force their way through the water. The exact nature of this corrosive force is not yet appreciated, but it is the case that with certain propellers it has proved so severe as to entail replacement after a voyage of a few months duration. Until a few years ago propellers were nearly always made of cast iron, but recently bronze propellers have been introduced owing to their superior tensile strength and decreased liability to corrode. Bronze is, however, a metal much more easily set in continuous vibration than iron—as witness its employment for bell founding—and its adoption has brought in its train a new phenomenon to beset the harassed ship engineer, called, for want of a more trenchant name, the ‘singing propeller.’

An uncanny feature of these cases is that the trouble often does not develop until the ship goes to sea, the basin trials with the propeller submerged to different depths not leading the owners to suspect anything wrong, while of propellers made to identical patterns and as far as instruments can detect of equal size, one may become a singer and the other remain forever dumb.

The acoustic features of the phenomenon may be summarised as follows:

(1) The sound is rather difficult to describe but is somewhat like that which would be expected if the blade received a blow with a moderately hard hammer once in each revolution. The low-pitched components of the ‘grouching’ noise thus resulting are rapidly damped, but the high-pitched components remain as a metallic ringing from one impulse to the next.

(2) The noise is only blatant over a certain range of engine speeds, reaching a maximum and then waning as the revolutions per minute are increased through the noisy range.

(3) The pitch of the continuous ringing may be identified with one or other of the torsional vibrations of the blade. The pitch of the most favoured partial tone changes with the speed of revolution.

(4) The noise is only important when an alloy of suitable

elastic properties, such as bronze or stainless steel, is used. Secular changes in the structure of the alloy may abate or aggravate it.

(5) The same effect may be produced by a change of helm or of physical properties of the water.

In the minds of many naval engineers the singing of a propeller is closely bound up with the corrosion which it often experiences in use. To the extent that corrosion changes the physical properties and configuration of a propeller, it is bound to have an influence on its acoustic properties, but it is not yet proven that the noise is due to the same cause as the corrosion, i.e. the liberation of dissolved gas as the blades lash the water. There is also the difficulty of explaining fact (3) on these lines, since one cannot conceive an obvious reason why the frequency of degassing should be a function of the speed. A more likely cause is to be found in the æolian vortices formed behind the blades and which trace out helical paths in the wake as the blades rotate. The vibrations so forced on the blades would be considerably enhanced if they happened to coincide with one of the natural frequencies of the blade in a transverse or flexural mode, and the collapsing of the liberated gas into these vortices might further add to the energy available for exciting noise. In this connection some experiments of Messrs. Stowell and Deming are pertinent. They idealised a propeller into a uniform rod of circular section, pierced at its mid-point by an axle about which it was revolved by an electric motor, while they picked up the sound produced on a microphone. The sound spectra so obtained illustrate clearly how the pitch of the hum shifts from one set of partial tones to another as the revolutions per minute of the rod is increased. The highest component in each case corresponds to the frequency of production of vortices at the fastest-moving portion of the rod, i.e. the tips. This would account for the possibility of exciting vibrations at quite a range of speeds. At the same time, disturbances from upstream of the propeller, e.g. those produced at the stern post, which preserve for a time their relative positions, produce additional impulses on

the screw co-periodic with the revolutions. Such probably give rise to the highly damped vibrations at low revolutions. In the view of the writer, the phenomenon of the singing propeller comes within the scope of relaxation oscillations. These are produced whenever a system receives regular impulses sufficiently detached to allow it to oscillate in one or other of its degrees of freedom with diminishing amplitude between each impetus. This would account for (1). The permissible vibrations of the blades of a scale model flat-bladed propeller have been studied by Hunter in the familiar method of Chladni dust figures used in studying the modes of vibration of metal plates, bowing at various places to exhibit the modes of vibration when the real propeller is excited at corresponding points. These model experiments were done in air and the working stresses were absent, so that, as the author points out, the sound was far more musical and tolerable than that which occurs at sea; under no conditions was the distressing grinding or grating of noisy propellers set up in the model.

It will be appropriate at this point to discuss the transmission of sound and vibration in general and in its application to ships in particular, since it is a matter of great importance on passenger liners. Before one can properly discuss this question units of measurement must be agreed upon. Noises are complex sound made up of a number of tones of varied pitch and intensity. The noise can be analysed by suitable instruments into constituent frequencies and the strength of the components measured. Unfortunately, such an analysis is not very helpful for present purposes, as attempts to deal with each constituent separately would be impractical. Moreover, the 'spectrum' of a noise may change from one second to the next. The ear, even if it cannot perform the analysis into constituents of such a complex sound as a noise, does have a sense of the general quality of a noise and of its loudness. In respect of both pitch and loudness the ear, like the other sense organs, estimates relative and not absolute values of the stimulus. Thus, we can tell when the pitch of a note is double

that of a previously heard one or when the sound is doubled in intensity while the pitch remains constant, but we cannot, save as a feat of memory, tell how many vibrations per second a sounding body is giving or what is the amplitude of the pressure fluctuations produced by it on the ear drum. Intensity must therefore be measured on a geometric scale, whose starting-point is the intensity of the barely audible sound at that particular pitch. The logarithm of the ratio of the actual intensity to the minimum is the intensity, reckoned in units called, after the telephone pioneer, 'bels.' One-tenth of this unit is more convenient in practice, and is called the 'decibel.' The table below gives some typical noise levels in order to show how this scale applies in practice:

In close proximity to aeroplane engine	. . . . .	100 decibels
"    "    "    pneumatic drill	. . . . .	90     "
City traffic in noisy street	. . . . .	70     "
Thunder	. . . . .	60     "
Ship's siren at a distance of 100 yards	. . . . .	60     "
Quiet residential street	. . . . .	40     "
Ordinary speech at 4 feet	. . . . .	25     "
Whisper at 4 feet	. . . . .	10     "
Inaudible	. . . . .	0     "

As the ear is not equally sensitive over the whole audible gamut of frequencies (about 20 to 20,000 vibrations per second) the standard 'minimum audibility' does not represent the same amount of acoustic energy over the whole pitch range. Thus the normal ear is more sensitive to the middle of the musical scale, which means that the minimum audibility is lower in this region than it is in the treble or bass. This complication, together with the difficulty of making precise estimates of the least perceptible intensity for the normal ear over a scope of several octaves, has led to the adoption of an alternative unit, the 'phon,' which is of the same nature as the decibel but takes as standpoint the minimum audibility of a tone of one thousand vibrations per second. The standard pitch and intensity is thus a constant one no matter what the

reference pitch may be, and only the one threshold of intensity for a normal ear has to be defined. From the point of view of the physicist and the engineer this is an advantage, indeed they would be satisfied with a purely artificial standard provided it could readily be reproduced, for example by putting the ear at a specified distance from a thousand-cycle tuning-fork having a measured amplitude of vibration. Nevertheless measurement in terms of the bel gives a better picture of how the ear estimates noise. It is, of course, fairly easy to convert one set of units into the other at any given pitch.

We shall describe later (Chapter IV) the way in which noise can be measured, but we must now indicate what can be done if, in a given location, an undesirably high noise level is found. Of course, much can be done by treatment at the source. Machines must be mounted on supports which are not set into resonant vibration and, even if subject to forced vibrations from the engine, have properties that initiate some damping of the noise or vibration. Pads of rubber may be interposed between the base of the machine and its foundation so that these two are coupled only through the rubber, i.e. no rigid bolts should pass directly from machine to foundation. This will not be possible when the machine in question is the main driving engine of the ship, but even when the engineer is restricted to rigid coupling of moving parts much may be done in noise reduction by paying attention to such matters as (1) prevention of moving contact between hard unyielding surfaces, (2) prevention of sudden discontinuities or accelerations in the motion, the chattering of valves, the sudden exhaust of high-pressure gases into the atmosphere (to be obviated by the gradual lowering of pressure through a silencer), (3) oiling of moving parts to prevent squeaks induced by friction, (4) balancing the machinery so that as far as possible moving parts have equal inertia.

Whenever sound in transmission strikes a medium of different physical properties a certain amount of reflection occurs. The rest of the energy passes on and is either absorbed or transmitted by the second medium. The factor which characterises

the behaviour of a medium in this respect is the product of the velocity of sound in it and its density. If two neighbouring media have identical values for this transmission factor, then sound will pass freely from one to the other without reflection; but if the values differ very much, then a considerable portion of the energy is sent back at the boundary and little is transmitted into the second structure. A knowledge of the reflection and transmission coefficients of building materials to sound is thus of great importance, but we shall defer consideration of the methods by which such information is obtained until a later chapter, confining our attention at present to the application of the general principles to the noise reduction in ships. From the foregoing theoretical considerations, the conditions for the isolation of sounds may be summarised as follows:

(a) Structure-borne sounds. Discontinuities in the structure should be introduced so as to produce a marked diminution in the acoustic energy penetrating each new panel of the composite partition. Damping should be a feature of the intervening strata whenever feasible.

(b) Air-borne sounds. The use of more or less porous materials permits the sound incident upon them to be absorbed by dissipation in the pores.

Methods of application present some difficulty on board ship inasmuch as there are various regulations to be met which were established in the days before acoustic treatment was thought of. The use of constructions which would be possible from the practical standpoint on land are often impracticable on seagoing vessels. The presence of so many angles and stiffeners on the surfaces to be dealt with makes it difficult to satisfy these theoretical requirements of isolation through the construction. If the angles are left uncovered they tend to conduct sound and nullify the work done on the plane portion of the surface. The acoustic engineer is left with two alternatives in carrying out his work, these being:

(1) To carry the insulation directly against the plates forming the walls and work round each stiffener, or

(2) To work over a dummy wall formed by a plane over the ends of the stiffeners, leaving an air space between this and the main plates. The latter construction would in fact add to the efficacy of the isolation but is often forbidden on technical grounds. Fig. 4 shows how the cabin walls of the M.V.

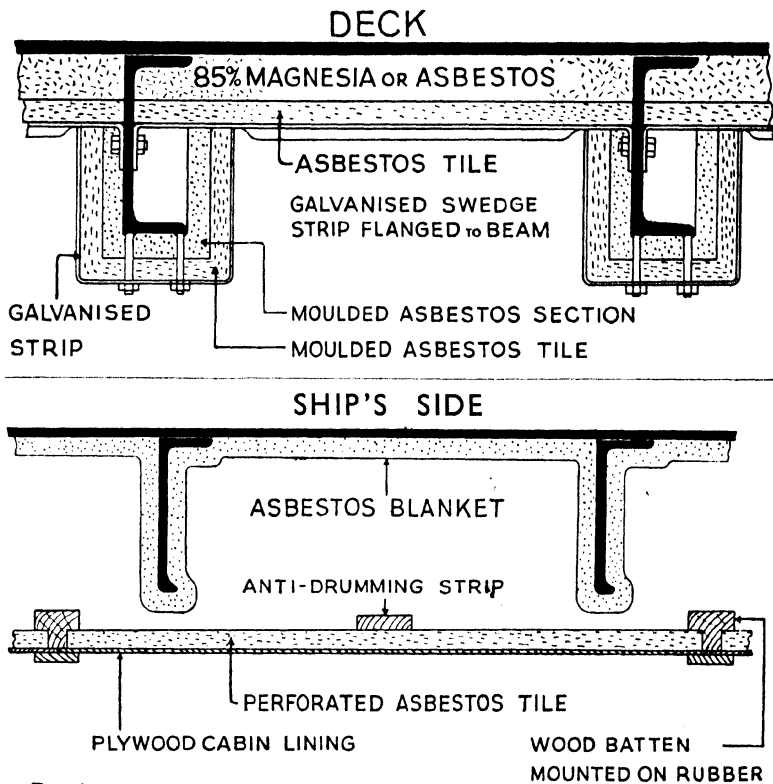

FIG. 4.—TYPES OF NOISE INSULATION ON SHIP FRAMES (*Newall's Insulation Co.*)

*Ulster Queen* were treated, (*above*) following the first method, and (*below*) the second method. The partitions also were isolated by rubber padding from the main walls. The wave form of the transmitted noise from the engines was recorded before and after the work was carried out, the results at four likely cruising speeds being shown on Fig. 5, from which it is evident that a considerable reduction was effected. It usually happens

that as the engines are speeded up the noise level in any part of the ship rises rapidly at first—rather irregularly as the engine revolutions strike one or other of the resonances proper to components in the structure—but more slowly eventually until a maximum is reached, beyond which an increase in revolutions scarcely affects the noise. The mounting of the prime movers to the seatings or main girders across the bottom of the engine, in the fashion indicated earlier, does not offer much practical scope, for, although so desirable from an

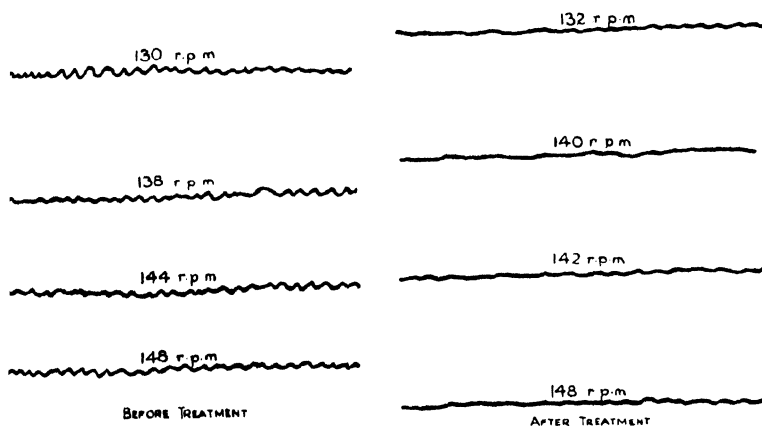

FIG. 5.—ENGINE NOISE IN CABINS BEFORE AND AFTER INSULATION AT VARIOUS ENGINE SPEEDS, M.V. "ULSTER QUEEN" (*Newall's Insulation Co.*).

acoustical point of view, the requirements of rigidity and accurate alignment here outweigh all other considerations. Auxiliary units such as ventilator fans, battery charging units, etc., can be mounted on rubber pads to great advantage, thus cutting off important structure-borne noises at their source.

Since seagoing vessels are for the most part travelling through a very turbulent medium it might be thought unnecessary for the designer to worry about niceties of form. This is not so, however, and much research has been prosecuted in recent years into the best shape for a ship to produce the minimum of resistance. Streamlining below and—as far as the larger protuberances are concerned—above the water-line is resorted

to. Besides the usual skin friction and eddy-making resistance to which every object traversing a fluid medium is subject, a surface vessel experiences another waste of energy in respect of the waves which its passage sets up. Large boats at high speeds originate quite high crests both at the bows and the stern, and work is done by the engines in lifting up the water against the force of gravity to form these diverging waves. It is also harmful to the banks of canals when the craft is so confined, and the speed must then be kept quite low to avoid erosion.

The wave-making resistance can be kept down by suitable shaping of the fore-part of the vessel and the avoidance of certain critical speeds. The angle with which the stem meets the water and the rate at which the water-line diverges from the stem to meet the parallel part of the ship's sides are modified in cut-and-try methods until the best model shape at the scale speed appropriate to the test is reached. Critical speeds arise in this way; the bow wave and the stern wave travel out—like most wave systems—in all directions continuously from the point at which these sudden changes in form make contact with the water. The envelope of the diverging crests from these centres of disturbance forms the arrow-head bow wave and stern wave respectively from whose angle the pilot of an aeroplane overhead can judge the speed of the ship relative to the sea. More important from the point of view of the resistance is the fact that the two systems, passing alongside the hull, the one back and the other forward, with velocities compounded of the speed of propagation and that of the boat, interfere; that is to say, produce a resultant series of crests and troughs whose height is the algebraic sum of the separate disturbances. At certain speeds of the vessel the combination will give rise to 'standing waves' which move along unchanged in position relative to the ship and appear stationary to a person on deck. These critical speeds will obviously depend on the velocity of propagation of the waves and on the distance between the sources of disturbance, i.e. on the length of the vessel. At low speeds conditions

with several 'nodes' in the standing waves may occur, but the crests and the increment of resistance are then slight. It is when a single large crest near the bows followed by a deep depression (corresponding to the length of the ship being nearly a whole number of wave-lengths in the pseudo stationary waves) is set up that the resistance increases enormously. In practice the vessel must cruise at values below this ultimate critical speed.

As the vessel may not be equally loaded on all occasions, the midships section must be watched as well as the longitudinal plan at the water-line. Endeavour must be made to damp out that part of the wave which, formed at the bow, travels along the hull of the ship. This can be assured to a certain extent by bulging the hull amidships just above the normal water-line. Attempts have been made to improve the flow by giving the water-line on either side a constant curvature instead of the more usual diminishing radius of curvature near the stem and stern with a stretch of 'parallel body' between. Up to the present there is little evidence to show that this 'arc form' is any improvement on the old.

Models of boats carefully made in wax are first tested in a long water tank, such as that named after the pioneer Froude at the National Physical Laboratory. The resistance of the model can therein be determined at a number of scale speeds. The earliest experiments of this type were those carried out in 1775 by d'Alembert and Bossut on a piece of water belonging to the *École Militaire* at Versailles. They attached a string to the model, passed it under a pulley at one end of the pond, over another in the branches of a tree, and hung a weight on the free end. As the weight fell the model shortly attained a limiting speed at which the resistance (which naturally increases with velocity) balanced the tugging force of the weight. Using different weights, it was thus possible to determine the resistance corresponding to a number of speeds. Nowadays, a machine tows the model along the tank while a balance fixed to the tow rope records the tractive effort exerted.

Physics plays an important part in the navigation of a ship.

It would be difficult to conceive how the journeys of men like Marco Polo and Columbus could have been brought to a successful conclusion without the aid of the magnetic compass; although in its absence other ways of taking a bearing—apart altogether from astronomical information—would be available to the navigator in this Year of Grace. The earliest types were nothing more than a piece of card, to which a piece of magnetic material had been attached, made to float on a liquid surface, but at the present time more elaborate arrangements, usually dependent on the gyroscopic principle, are made to ensure that the compass preserves an even keel in spite of the rolling or pitching of the craft. Since the compass is affected by neighbouring masses of iron, it is usual to let the ship, on commission, swing round its anchor in port with change of tide to disclose such actions. As the earth's magnetic action is constant during the short time that these evolutions take, any change in apparent bearing, other than that due to swinging the ship, is to be ascribed to disturbing influences on board ship and is to be counteracted by fixed pieces of iron set up near the compass until the spurious effect has been neutralised.

Navigation in shallow and obscured waters has been much facilitated in recent years by the invention of a number of pieces of apparatus based on the propagation of sound waves either through the atmosphere or through the sea. If the vessel is equipped with submarine microphones, a surer indication can be derived from sounds traversing the sea than from those in the air above it, subject as these are to deflection by wind or absorption by fog. It is the practice to send out from important lighthouse stations simultaneous sound and wireless signals, both of which can be picked up by ships in the vicinity. The arrival of the latter being practically instantaneous, the time which elapses until the submarine sound is picked up gives an accurate indication of the ship's distance from the lighthouse. If there are two microphones, one on each side of the ship, the bearing of the source of sound can also be obtained. If the ship is steering directly towards the source and the micro-

phones have been adjusted for equal sensitivity they will be equally excited. Otherwise the signal picked up will appear louder on that side of the hull which faces the direction from which the sound is coming and the pilot having a stethoscope connecting the microphones severally to his ears will be able to lay a course accordingly. In one type of apparatus the currents from the two microphones are, after amplification, fed to loud-speakers which can be moved along respective tubes, one connected to each ear of the pilot. If, when the loud-speakers are at equal distances from the two ears, one sounds louder than the other, the pilot moves this one farther down the tube until equality has been attained. This is done by a handle working over a dial on which the bearing of the source of sound is read directly.

Alternatively, a single microphone furnished with a baffle may be employed. This is turned in the water until the sound picked up is a maximum, in which position the baffle is directly facing the source. In the 'light-body hydrophone' developed by the British Navy during the war of 1914-18, the baffle was a lens-shaped case, while the microphone itself was placed in a boss in the centre of the case, consisting of a volume of air in a glass vessel. The case being less dense than the surrounding water vibrated with a greater amplitude than the water through which the sounds came. The principle of this device is, in fact, that when a body is set in forced vibration by sounds coming through the surrounding medium, the relative amplitudes of the two vibrations are inversely as the respective densities. (In the same way, light sand grains on a steel telephone diaphragm dance to considerable heights when the diaphragm is given a feeble oscillation of weak amplitude.) This light body thus gave good amplification in detection in the days before the development of amplifiers employing thermionic valves.

In taking soundings, two physical methods depending on sound propagation are available, more elaborate than the still very common line and sinker and less subject to error.

We have already outlined the sound and light or wireless

signal method for determining the distance of a ship from a signal station. When the sound signal is given by a submerged bell, the value of the velocity in water is obviously necessary to determine the required distance. There is, however, another important application in which this quantity is involved and that is the determination of the depth to the bottom of the sea or channel in which a vessel floats, by noting the time for a sound to travel to the bottom, to be reflected and to return to the vessel. The idea of this 'echo-sounding' goes back to the middle of the nineteenth century, but has been brought into practical use only within the last few years, not without contesting a number of difficulties which presented themselves. The earlier photographic apparatus of Behm involved the projection of the light from a small lamp by a rotating mirror on to a sensitised film. In the absence of disturbance the beam of light drew a straight line on the film, but at the instant of firing a cartridge in the water to one side of the vessel, a second mirror in the path of the beam of light and connected mechanically to the diaphragm of the microphone on the opposite side of the vessel was disturbed, causing the trace to follow an unevenly sinuous track, which continued until the sound returned from the bottom of the sea and struck the microphone, causing a second and more violent agitation. The first disturbance was found to be due to direct propagation of sound through the iron hull of the vessel (at about 5,000 metres per second) and was continued by waves diffracted round the hull through the water. The time of passage of the sound to the bottom and back was given by that between the first disturbance and the later more vigorous one, when the time of transit through the hull could be neglected. The echo time was found by comparison with a trace from a tuning-fork of frequency 1,440 side-by-side with the trace from the microphone on the film. Since the velocity of sound was nearly 1,440 metres per second, every complete vibration on the fork represented one-half metre of depth—remembering the double path of the sound.

This apparatus had two defects—the 'lag' in registering the

sending out of the pulse, the delay in developing the traces—the latter rendering it useless as a sounding device for the use of the ordinary ship's personnel. Behm himself has devised a dial instrument, in which the action of firing the cartridge starts a disc in motion at a constant and fixed speed; the arrival of the sound at the microphone brings a brake into action, which instantly stops the wheel. A pointer moving with the disc gives the sounding directly on a scale graduated in metres. This instrument requires careful screening of the microphone from the direct transmission through or round the hull.

The instrument used by the British and U.S. Navies based on Fessenden's Principle is superior in this respect, and more compact, as source, microphone, and registering device are incorporated in one instrument. A drum rotating at a constant slow speed carries two pairs of contacts. The first pair actuate electrically a submerged bell or hammer, every time they pass two (fixed) brushes. The second pair periodically pass under two other brushes, which connect telephones (on the bridge) to submerged microphones close to the bell. These brushes can be moved round the disc relative to the first pair. If both sets of brushes are together, the sound of the direct transmission over the negligible distance between bell and microphone will be heard. If the second brushes be now displaced so that the microphone contact lags behind the bell contact, no sound will be heard in the microphone, until the lag has been so far increased that the noise in the microphone caused by the sound returned from the sea-bottom is caught. The scale showing the angular displacement of the brushes is graduated to read the depth in feet.

An interesting application of the 'Behm-lot,' as the inventor styles it, has been made to the determination of the height of air-vessels, and of the nature of the earth or water surface over which they lie, when in fog or darkness.

The principle of this apparatus is a combination of that of the photographic type with that of the revolving wheel. The sounding is indicated to the pilot by movement of a spot of light along a ground glass scale in place of the sensitised film.

The beam of light is again given two displacements, one a transverse oscillation actuated by the microphone which receives the echo, and the other a vertical movement at constant speed started by the firing of the cartridge. At this instant the spot of light begins to travel, more or less in a straight line, vertically up and down the scale, until the return of the sound throws it into violent oscillation, in which it continues with diminishing amplitude until it disappears from view. The oscillations are presumably the natural vibrations of the diaphragm of the microphone since the source of sound is a sharp pulse. The vertical distance traversed by the spot of light

before the disturbance strikes it gives the pilot his height in metres. The scale of such an instrument is shown in Fig. 6, with a typical trace as it would appear to the pilot. These echo altimeters are designed for sounding at low altitudes, for landing by night or in fog, since they cannot compete with the barometer for convenience at greater heights.

But the instrument is designed to give more information than the mere height. The *intensity* of the echo will depend not only on the distance from the surface below (this will fall off as the square of the distance), but also on the form of the surface. Water—as everyone must have noticed at the seaside—is a good reflector of aerial sound waves, hard ground rather less, soft or snow-covered ground still less. It is therefore possible, to a certain extent, to distinguish at a particular altitude what type of country is causing the reflection. Alongside the vertical scale in Fig. 6

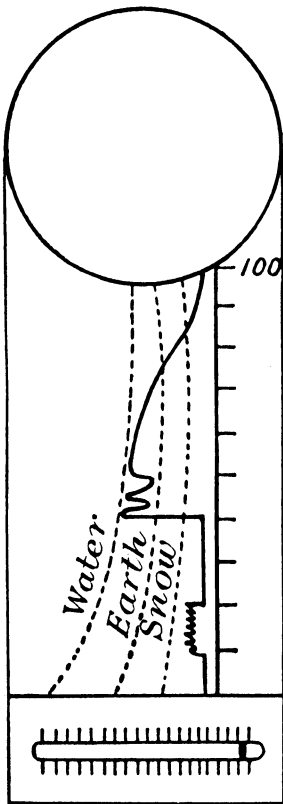

FIG. 6.—ECHO-SOUNDING APPARATUS (Behm)

will be noticed three dotted lines, which give, from an empirical calibration, the intensity of the echo returned by the three typical surfaces, from a source of standard intensity, i.e. the average produced by the cartridges employed. To allow for possible variations of the intensity of the pulse given by the latter, another microphone measures this intensity by the horizontal deflection of another beam of light at the base of the instrument—rather a lot for the poor pilot to observe at once, perhaps, but indicative of the possibilities of echo-sounding, which will be improved and developed as time goes on.

A further possibility of the method is suggested by a sounding taken over a surface with a table placed on it. With the instrument at an altitude of some three metres, the record showed, beside an echo from the table, a less intense disturbance from the floor below. In view of this experiment it is claimed that a pilot could distinguish between flat and broken ground, and choose his landing-place accordingly. Larger inequalities such as hills, or islands in the sea, could be detected by repeated soundings from a greater height.

It is obvious that when the Behm apparatus, with its source and receiver on opposite sides of the vessel, is applied to an aeroplane, the screening of the direct sound-ray through the vessel is more difficult to accomplish than when the bulk of a large ship lies between them; and, moreover, the direct distance between source and microphone becomes comparable with the sounding to be taken at the slight altitude for which the air sounder is intended. To effectually screen the microphone from the direct ray, it has been found necessary to direct the initial impulse downwards, and to 'cut out' the receiving microphone at the instant of firing.

It is essential to remember that the energy reflected by a surface when the source gives out a single or a limited train of waves separated by a considerable period will depend on the angle subtended by the surface at the source, so that the echo sent back by a surface of limited extent will diminish in intensity as its distance from the source is increased; in fact, the energy reflected will vary inversely as the square of the distance.

The same applies to a source which gives a continuous tone of low frequency, with the additional fact that bending of the sound round the object will take place to an extent which increases with the tenuity of the obstacle and the wave-length of sound. Remembering, again, that on account of the increased velocity the wave-length of a given tone in water is 4.3 times that of the same tone in air, we see that an attempt to locate an iceberg, for example, or another ship on the sea, must fail if echo-detectors of the type at present described were used, except at distances within which their presence would be obvious.

The problem is analogous to that of a lantern and a small mirror at a distance by which we hope to reflect light back to the lantern. The amount of light reflected will be negligible, unless we concentrate the light of the lantern upon it in the form of a beam.

If we attempt to make a beam of sound by allowing the waves to pass through an aperture, we are faced with the difficulty that the apertures we meet with in practice are large, or at any rate of the same order as the wave-length of sound (the wave-length of 'middle C' is 5.7 metres in water), and in such cases we know from optical analogies that the radiation is not propagated in straight lines through the aperture but spreads in every direction. To concentrate the sound energy into a beam by passing it through an aperture of reasonable size it becomes necessary to employ wave-lengths of a few centimetres; the beam can then be focused on the reflecting surface.

It occurred to Prof. Langevin during the 1914-18 war to employ the vibrations of a quartz crystal excited piezo-electrically. What may be called the static piezo-electric phenomenon has been known a long time. If two metallic plates are fixed to opposite faces of a quartz crystal and a current passed between them in a direction perpendicular to one of the 'electric axes' of the crystal, a slight elongation takes place in a direction perpendicular to both electric current and optic axis. On turning off the current the crystal contracts again. If intermittent or alternating current be supplied to the crystal, oscillations of the crystal will take place owing to the rapid elongations and con-

tractions, but the movements excited by this dynamical piezo-electric effect will be of very small amplitude, unless the frequency of the intermittent current coincides with one of those—either fundamental or harmonic—natural to the crystal, i.e. when the crystal and current are in resonance. Since the slices of quartz employed are of quite small dimensions, the fundamental vibration is of very high frequency, usually above the audible limit—about 40,000 per second; hence their suitability for transmitting waves of short wave-length into the surrounding medium. It is not feasible to produce alternating currents of this frequency by the ordinary means, but the thermionic valve supplies the solution. It is known that oscillations taking place in the grid circuit of a valve are magnified in the plate circuit, and these again react upon the former, tending, under suitable conditions, to maintain them.

Accordingly the crystal with its connecting electrodes is placed in the grid circuit, with sufficient capacity and inductance to excite and maintain the fundamental vibration of the quartz 'resonator.' Then supersonic waves, a few centimetres long, if sent out through a small hole, will be concentrated into a beam without appreciable spreading on either side of the hole, owing to the small wave-length compared to the aperture, herein differing from the sounds of the normal speech range. Actually an *ad hoc* aperture is not needed, the confines of the crystal and electrodes being sufficient to compress the energy into a beam of practically plane waves in a direction parallel to the electric axis. If the waves strike a solid surface lying normal to their course, they will be reflected and will strike the crystal again.

With this energy available, it is possible to send a beam upon the sea bed 450 metres down, in spite of the damping of amplitude suffered by the waves in their transit, and still obtain a 'readable' echo. Ultrasonic soundings have the advantage of a certain amount of secrecy, since the waves are inaudible. It is not to be supposed on that account that they are without action on the aural or other organs of the body; the fishes which happened to be in the experimental tank were killed by the action of the ultrasonic waves!

SOURCES

- Baker: "Ship Wake" (Trans. N.E. Coast Inst. Eng. & Shipbuilders, **46**, 83, 1930, and **51**, 303, 1933.)
- H. Hunter: "Singing Propellers" (Trans. N.E. Coast Inst. Eng. & Shipbuilders, **53**, 189, 1937).
- E. G. Richardson: "The Rocket as Means of Locomotion" (Science Progress, **26**, 109, 1931).
- "Insulation and Prevention of Noise" (Trans. N.E. Coast Inst. Eng. & Shipbuilders, **48**, 181, 1932).
- "Singing Propellers" (Engineering, **144**, 170, 1937).
- R. S. Robinson: "Noise Reduction in Ships" (Trans. Inst. Marine Eng., **50**, 259, 1938).

JOURNALS

Trans. N.E. Coast Inst. Eng. & Shipbuilders; Trans. Inst. Marine Engin.

### CHAPTER III

## THE PHYSICS OF LOCOMOTION: AEROPLANES

THE aeroplane is such a common sight to us that it is a little staggering to realise that only forty years separate us from the day that the Wright brothers made their first epoch-making flight in an engined heavier-than-air machine in the United States. This, of course, does not mean to say that voyages through the air were previously unknown, but that hitherto the intrepid aeronauts had been more or less at the mercy of the wind. Aeronautical research in this country began with the home work of Sir George Cayley a century ago, was continued by Stringfellow and Henson on model gliders, flown in an empty lace factory since they found out-of-doors too boisterous for fundamental research, as well as being destructive of the fragile models. Two factors contributed to the rather long delay which followed these experiments before man conquered the air. The one was the need to discover a suitable lifting surface having a small drag resistance. This was accomplished by Lanchester, who evolved the aerofoil section as a body possessing circulation—and, therefore, lift—like the rotating circular cylinder. The other was an engineering rather than a physical lack, though more serious than the former, i.e. the absence of light motive power before the internal combustion engine came along. Some of the early models were driven by small steam engines, but they did little more than lift themselves for a few seconds into the air at their first—and often last—hop. Nowadays, models are still used—in advance of the construction of the full-size 'plane—and are tested in a wind tunnel to aid the designer in his task and to predict, as far as possible, the characteristics of the prototype.

Broadly speaking, there are three types of wind tunnel.

The original one, designed by the French engineer, Eiffel, of Tower fame, for measuring the wind resistance of various simple shapes as well as complete models, was of the open jet type (Fig. 8). In most tunnels, however, the wind is aspirated through a long box (Fig. 7). The section may be anything from eighteen inches up to seven feet square, with two conical attachments at either end. The entry is rounded off to induce a flow free from large disturbances (although some small-scale turbulence cannot be excluded, this does not upset the results). At the exit the section must change gradually from square to round to meet the circumference of the imaginary disc swept out by the blades of the fan. Each end of the box has therefore a cone attached to it; obtuse at the suction end, more

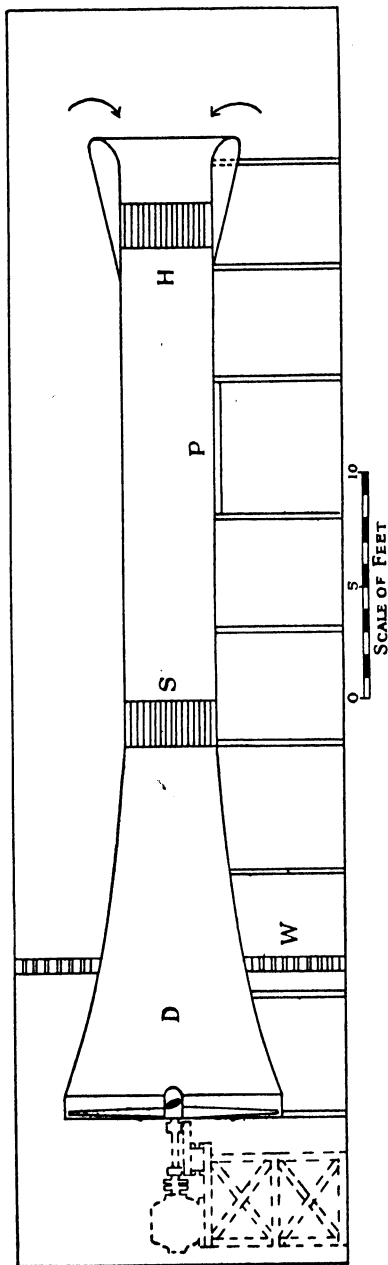

FIG. 7.—WIND TUNNEL, CLOSED TYPE (Piercy)

H, inlet honeycomb; P, plane table; S, guard grid (which need not be a honeycomb); D, regenerative cone; W, honeycomb wall.

acute at the exhaust end. Further, to prevent undue swirling of the air on the part of the fan, honeycombs are placed at each end of the square section. These consist of sheets of tinfoil placed criss-cross fashion and look rather like the interior partitions of egg-boxes. The model must be placed at such a distance from the throat of the tunnel that conditions in the wind stream have more or less settled down, say at about half a dozen diameters and some two-thirds of the total length. This limitation makes the total length, including entrance and exit cones of a four-foot-square tunnel (an average laboratory size), to be fifty feet. The power required from the motor driving the fan and the total amount of material used in the construction naturally rise very rapidly with the cross-section of the channel, placing the seven-foot tunnel in a class by itself as a monopoly of state testing laboratories. Windows are provided at the testing section for adjustment of the models and for noting their behaviour.

When the open jet is used, continuous circulation of the air in a sealed chamber usually takes place. This necessitates the provision of guiding vanes (Fig. 8) to get the air neatly round the corners of the circus. The jet is totally enclosed save for the experimental space, where the model is set up, both edges of the metal case being faired off at this point and so arranged that the jet suffers a slight expansion. This is because it is found that a contraction just before the open portion is reached steadies the air somewhat. Although in this type one avoids any corrections to the forces measured on the models for the friction suffered by the air stream in riding along the walls, it is naturally easier to secure uniformity of flow over the jet when it is perfectly straight.

Recently the totally enclosed roundabout tunnel of the Eiffel type has been further developed. The whole chamber enclosing the tunnel is hermetically sealed and raised to a high pressure (up to twenty-five atmospheres); in fact, the chamber consists of a large steel shell able to withstand the pressure. In the one erected at the National Physical Laboratory, the experimental portion is formed of a central tube six feet in

diameter along which the compressed air is aspirated to be returned to the suction end through the annular space between this tube and the outer shell. The object of using air under pressure will appear in what follows.

The force balance which measures the effect of the draught



SECTION OF CASCADE VANE

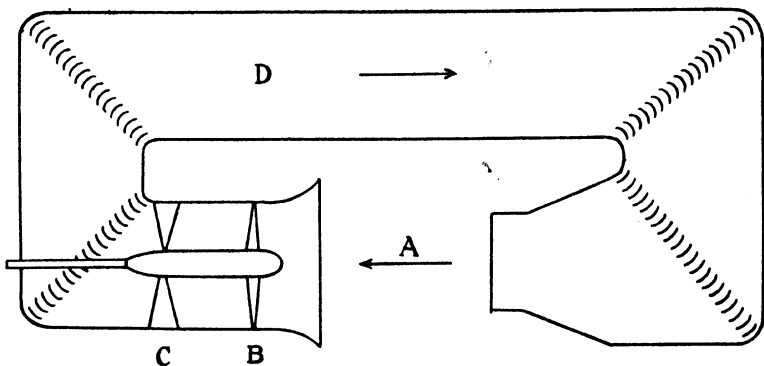
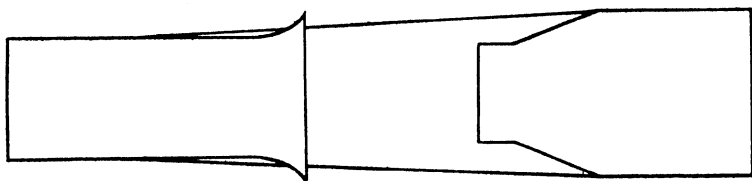

FIG. 8.—WIND TUNNEL, OPEN-JET TYPE (*Piercy*)

A, jet; B, airscrew; C, ring of straighteners; D, divergent diffuser.

on the model consists essentially of a lever pivoted in one of the side walls of the tunnel by a joint which, if not 'universal,' should be capable of movement in at least two azimuths, one in a line parallel to the axis of the tunnel and one perpendicular to this. The best arrangement uses for a pivot a thin steel diaphragm through which the balance arm passes and to

which it is bolted. The diaphragm is clamped round its circumference to the wall of the tunnel and so obviates the leakage of pressure which accompanies the free passage of the beam through a simple hole, an alternative device. The forces transmitted from the model to the lever may be measured by the shifting of weights, suitably disposed, along the beam, after the fashion familiar on the weighbridges of markets and railway goods stations, or the deflection of the beam may be opposed by compensating electrical attractions between coils carrying currents, one on the beam and one fixed to the channel supports. In a totally enclosed tunnel this second alternative or some similar apparatus is a necessity. Thus, in the compressed-air tunnel to which we have just referred, once the model is in position and the air compressed, one cannot get at the model or its supports to measure the aerodynamic forces. Accordingly, the model is mounted on a ring frame which can be made to pivot (by electric circuits operated through external switches) alternately about a vertical and a horizontal axis, and the force on the frame in each case is measured by applying compensating electric forces until the ring frame rides in the same position as in the absence of draught. As this condition is also signalled to the operator by electric contacts, the whole operation can be carried out 'blindfold.' If, on any model in a tunnel, there is a turning moment tending to twist the balance beam, the twist is taken out by a corresponding and measurable turning moment on the outer end of the beam.

If the axis of the tube (and therefore of the model) is horizontal, the force on the model is resolved into two components, one horizontal, known as the 'drag,' and the other a vertical constituent, or 'lift.' The designer naturally aims at producing a design for which the lift/drag ratio is high. This ratio is accordingly plotted (after the tests) on a graph for a number of reasonable angles of incidence of the wind upon the plane. On Fig. 9 the separate graphs of lift and drag for a typical aerofoil are shown.

When the aeroplane is moving horizontally through the air

at constant speed, the propulsive force of the engine acting through the airscrew balances the drag, while the lift equals the weight of the machine. If, however, the pilot tries to climb too steeply so that the angle of incidence of the relative

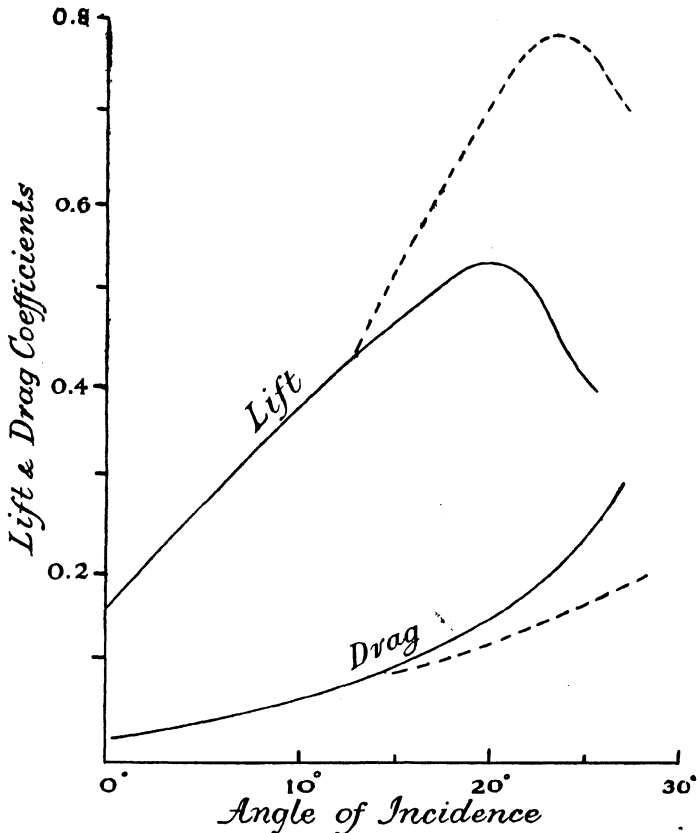

FIG. 9.—LIFT AND DRAG FOR TYPICAL AEROFOIL, UNSLOTTED (FULL LINE) AND WITH SLOT OPEN (BROKEN LINE)

wind on the wings rises to such a value that the lift falls off (cf. Fig. 9) to a value insufficient to sustain the weight of the load, while the engine is unable to overcome the increasing drag, the aeroplane stalls, i.e. falls back to earth and probably crashes before the pilot can right it. Evidently under these

circumstances an aerofoil section is demanded that has a large lift/drag ratio at high angles of incidence if stalling is to be prevented. This is the advantage of the slotted aerofoil. On opening a slot near the leading edge of the wing, air passes from the underside to join the sluggish air on the top, giving it sufficient kinetic energy to carry it to the trailing edge without breaking away into eddying, the prime cause of drag and small lift in an unslotted aerofoil at these angles of incidence. The dotted curve on our figure gives the lift curve for the same aerofoil when the slot is open, to show the increased lift/drag ratio above an incidence of twenty degrees. Below this its curve is not so favourable, but to offset this the slot may be closed for normal horizontal flight. In fact, the slot is normally shut by springs, but when a stall is imminent pressure of the air on the lower side of the wing opens the slot and automatically wards off the danger, or at least postpones it until the pilot has had time to reset the machine on an even keel.

The slot—although it is the most successful and widely used—is not the only invention in which a knowledge of the physics of air flow has been applied to reduce drag in the aeroplane. The German experimenter Schrenk was the inventor and most persistent advocate of devices which aimed at the inhibition of the breakdown of streamline flow round sharp corners or behind the bluff portions of models by means of apparatus involving the sucking of some of the air into the rear portions of wings. In his earliest experiments he used a sphere one foot in diameter, mounted in a wind tunnel and having ring-shaped slots contrived in the rear half through which air was sucked into the interior, to pass through the hollow tube of the force balance and finally through the aspirating pump into the atmosphere outside the tunnel once more. Under favourable conditions of suction, the resistance could be reduced to one-quarter of its value for the untouched sphere. By mixing smoke with the air passing near the sphere, he was able to demonstrate that the suction did in fact cut down the erstwhile turbulent wake behind the model.

We have now reached the stage at which we must consider

in some detail the validity of applying model results obtained in the laboratory to full-scale design and to the prediction of the behaviour of the actual machine or part when constructed. For this we must go back a little way in the history of hydrodynamics to some fundamental experiments, which—all unbeknown to their author—were to play a major part in the evolution of aeronautical research. In the year 1883 Osborne Reynolds carried out some experiments on the initiation of turbulence in the flow of water along glass tubes, whereby he gradually increased the speed until streamline motion broke down. To indicate the change of régime he allowed a fillet of ink from a siphon to pass along the axis of the tube. As long as the motion remained smooth the ink 'kept itself to itself' as a thin thread stretching along the tube from end to end; but when a certain critical value of the velocity was exceeded, the ink swirled round and round in spirals until the whole of the water in the tube was coloured by it except for a short length near the entry, which, being a convergent funnel, prevented turbulence *ab initio*. He found that this critical velocity was a constant factor for a given tube under the conditions of the experiment, but that if he changed the tube for a similar one of different diameter, the critical velocity changed in such a way that the product of it and the diameter remained constant. The only other relevant factor appeared to be one which was peculiar to the fluid in the pipe, viz. its 'kinematic viscosity,' which is descriptive of the specific resistance which the fluid offers to movement. If the kinematic viscosity of water were lowered by heating it, the critical velocity was lowered in like proportion. Summing up his results, he decided that turbulence would commence whenever the quantity, velocity  $\times$  diameter/kinematic viscosity, exceeded a certain number, roughly one thousand. (It may be remarked in parenthesis that the units in which these three factors are measured does not matter provided they are at least consistent, for this ratio has no dimensions.) This quantity has since come to be known as Reynolds' Number or Criterion. It is now known that every type of flow has a characteristic

Reynolds' Number, which determines when a change of régime will take place. But we can go further yet. If we have a model of an aircraft in the wind tunnel, not only will turbulence set in at the same value of the criterion for the model as for the prototype, but at any stage the flow round each will be similar—so that smoke pictures of the flow round each will look identical when reduced to the same size—if the Reynolds' Numbers for the flow round each are equal. Then all the aerodynamic forces on the one can be derived from the other. It appears, then, that we have only to secure equivalence in this respect for our model and full-size work to get all the information we wish in the wind tunnel. But this is not so easy in practice, for in the nature of things the model has a smaller diameter than its parent, so that it ought to be tested at a proportionally higher speed if both are to be tested in atmospheric air. With present-day cruising speeds of aeroplanes this is impossible, and so, willy-nilly, the practice has been to accept model tests at lower Reynolds' Numbers and to extrapolate to full scale. Fortunately over a considerable range of Reynolds' Numbers this scale factor is small, evidenced by tests on cylinders and spheres. Between  $R = 500$  and  $R = 500,000$  the régime is practically invariable. Only below this range, where the transition from streamline flow is taking place, and above it, where speeds approaching the velocity of sound make it so that compressibility of the air is no longer negligible, are marked changes apparent. The former range scarcely concerns aircraft, nor did the latter until recently.

In order to test models in channels at higher Reynolds' Numbers we must perforce change the viscosity of the fluid medium. The only liquid available in sufficient amounts for tunnel work is water, which has a kinematic viscosity about one-tenth of that of air, and so will raise the Reynolds' scale of any model by ten times. It is, unfortunately, so much more dense than air that much more power on the part of the actuating fan is required to move it along the tunnel at the same speed. It was suggested by Margoulis in 1920 that an enclosed wind tunnel might be filled with carbon dioxide which has a viscosity

two-thirds that of air, but actually the variable density tunnel as realised contains merely air whose pressure can be varied, since it is airtight, as we have already indicated. The kinematic viscosity of air decreases nearly in inverse proportion as the pressure increases, and in practice a compression of 25 : 1 is attainable. Thus, assuming that the wind speed in the tunnel can be kept the same as that in actual flight—a condition only reached with light aeroplanes—the model may be built to one-twenty-fifth scale and still retain full-scale Reynolds' Number.

At other laboratories attempts are being made to test an aeroplane at natural size in a wind channel of the open jet type. That at Chalais-Meudon in France has a working section six metres square. Even so, parts of the wings must of necessity project beyond the confines of the jet, and corrections to the observed forces must be made for this. The whole tunnel is an immense enclosed aerodrome, and since it would be impossible to construct a single fan of the size required to aspirate air over such an area, six separate fans are mounted side by side in the entrance cone of the jet which embouches directly from out-of-doors in the park housing the tunnel.

Some information on the forces acting on the different parts of an aeroplane may be obtained in actual flight, if self-recording dynamometers are fitted. For instance, one British monoplane has had springs fitted between its wings and the chassis to make records of the forces on the wings at different steady flight speeds in order to correlate these with similar observations on the same wings alone in a large tunnel and to obtain factors for the scale effect, if any.

It must not be supposed that model research is entirely taken up with the measurement of aerodynamic forces. Another important service which it affords is connected with the examination of the flow round models. It is often desirable to have knowledge of the distribution of velocity and pressure round a model aerofoil at various Reynolds' Numbers. The older instrument employed for this purpose is the Pitot tube. If a narrow tube is bent at a right angle near its open end so that this embouchure experiences the full force of the air

current—this means pointing it directly into the local wind at this point—an excess pressure is built up inside it (if the other end is plugged) whose value depends on the equivalence of the kinetic energy of the stream at the mouth and the potential energy of the air within the tube. The pressure built up inside is therefore a measure of the square of the velocity just outside the open end. The French engineer Pitot used this principle in 1730 to measure the speed with which a boat was being tugged along the Seine. He actually used a tube open at both ends. One end pointed upstream beneath the water, the other stood vertically out of the surface. The water rose in the vertical limb above the general level of the surface of the river by an amount proportional to the square of the speed of the boat. In aeronautical practice the pressure excess over the atmosphere (static pressure) is measured by connecting the Pitot tube and another tube (static tube) studded with holes set *sideways* to the direction of flow, one to each side of a gauge suitable for measuring small differences of pressure. In its simplest form this manometer can be a glass U-tube having a bubble of liquid which is pushed to and fro with the difference of pressure between its ends, somewhat in the fashion of a spirit-level. The same device, with a dial recording the difference of pressure, is used for measuring the velocity of the aeroplane itself through the air, the Pitot tube usually protruding above one of the wings.

Velocity is not the only indication which the Pitot tube can give. It can be shown by mathematics, which we shall not reproduce, that, if the variation of static pressure round a model be ignored altogether, the readings of the total pressure head from point to point round the model give a measure of the distribution of the vorticity or rotation of the air round the model. Thus, if one Pitot tube be placed well upstream while another is traversed across the stream behind an obstacle, the difference of pressure between the two tubes when connected through a gauge depends on the amount of eddying to be found at the embouchure of the latter Pitot tube. With a well-streamlined strut stretched across the channel, negligible

differences of total pressure head are to be found, but behind a bluff obstacle the pressure head falls to a low value and may be negative in some spots, i.e. less than atmospheric.

The use of the Pitot tube in a confined space or close to the surface of the model raises difficulties, for it can neither be made sufficiently small to record velocities in the crannies and boundary layers of models, nor can it be relied on not to upset the flow which it purports to measure in such a case—although ‘disappearing Pitot tubes’ which protrude, trap-door fashion, from the model itself have been tried with some success. When one wishes to measure such local velocities it is better to employ the cooling of an electrically heated wire, since such a detector can be made quite small—say a quarter of an inch of platinum wire one-thousandth of an inch in diameter. Further, it need not be heated so much above the surrounding air as to disturb the flow. The cooling effect of a given draught on the wire is usually ascertained in terms of the change of electrical resistance, measured in a Wheatstone bridge circuit. The calibration of the hot-wire is effected by exposing it to the unmodified draught in the centre of the empty wind tunnel, the velocity being at the same time measured with the usual Pitot and static tube. The relation between velocity and change of temperature (or of electrical resistance) of the wire is not a linear one. It is, however, possible to connect the wire in the grid circuit of a suitable valve amplifier so that the current in the plate circuit is directly proportional to the velocity, at any rate over a moderate range of speeds.

Fig. 10 shows a typical set of velocity results in the neighbourhood of an aerofoil set at a usual angle of incidence to the wind. The curves are actually contours of equal mean velocity and the number attached to each gives its value relative to the undisturbed stream velocity remote from the obstacle. For ease in drawing the scale of distances outwards from the aerofoil has been exaggerated eight times relative to the scale of distances along the surface. This distorts the actual pattern somewhat. In spite of this, the enhancement of velocity over the upper surface and reduction below it is self-evident; like-

wise the breakaway of flow over the back leaving a 'stagnant' region of reduced velocity in the wake.

The hot-wire readings are unfortunately subject to a correction when the wire is located in the boundary layer of air close to the surface of the model. The error arises in this wise. The wire is cooled partly by convection in the draught and

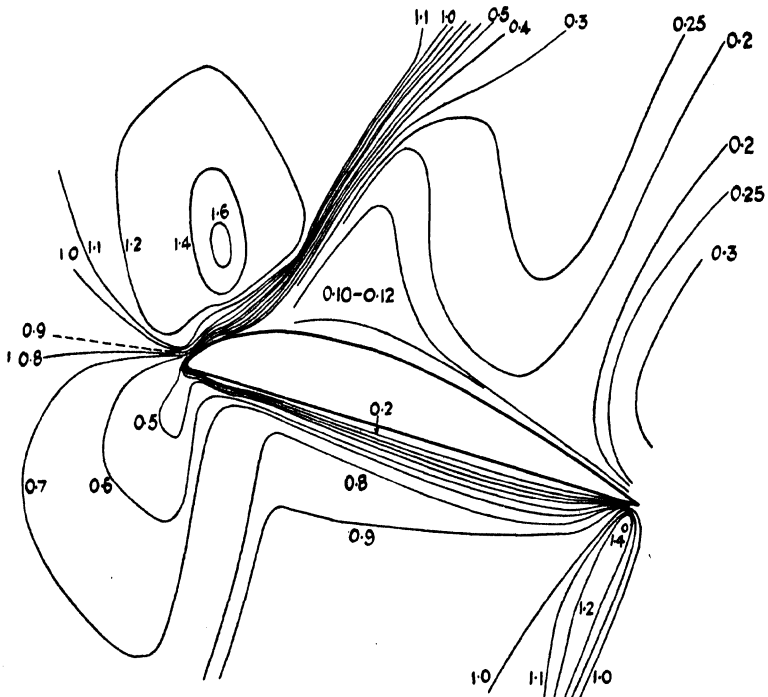

FIG. 10.—CONTOURS OF EQUAL VELOCITY ROUND AN AEROFOIL AT  $9.5^\circ$  INCIDENCE

The linear scale normal to the aerofoil is magnified eight times relative to that along the surface (*Piercy and Richardson*).

partly by conduction to neighbouring solid surfaces. The regular laws of cooling by convection, on which the calibration of the apparatus is established, apply only when the conduction loss is negligible, i.e. well away from the model and the tunnel walls. The nearer that the wire approaches one or other of these and the slower the air current in which it accordingly finds itself, the greater becomes the conduction loss in relation

to the convection, and the reading gives an apparent local velocity much exaggerated. Experiments have, however, established the magnitude of the necessary correction, and when this is applied to the readings of the hot-wire close to the surface of the model, one can always check the validity of its application by observing whether the velocity goes, as it should, to zero where the surface itself is attained. The results of Fig. 10 have been so corrected.

The hot-wire is equally suited to the detection of turbulent as of steady flow. In particular, when an aeroplane is in or near the stalled condition—which occurs when the wings meet the relative wind at a large angle of incidence—it is important to be able to tell at what point over the upper surface of the wings the breakaway of the air takes place. Over the forepart, where the air is being accelerated along the upward curving contour, the motion is usually steady, except for a small region enclosing the front ‘stagnation point’ (where the two fluid streams divide to pass one each side of the obstruction). At large angles of incidence, the fluid is unable to continue much beyond the maximum chord of the wing, but recedes from the surface, leaving a wake which is the seat of the eddying to which the large increase of drag just before a stall is due. When using a hot-wire to detect the extent of the eddying, the electric current which feeds it is passed through the primary coil of a transformer, whose secondary winding is connected in series with a rectifier or thermo-junction in order to record the mean value of the alternating current induced in the secondary by fluctuations in the primary current, which are in turn inaugurated by eddies or similar unsteady conditions in the air flow over the hot-wire. While an induced current in the secondary coil is a sure indication of unsteadiness in the local wind in which the wire finds itself, its magnitude is not a true measure of the mean value of the turbulence at that point unless the secondary coil forms part of a special circuit to compensate for the thermal lag of the hot-wire. Suffice it to say that a heated wire exposed to a vacillating wind responds rapidly when cooled by a gust but does not warm up so quickly

when the gust subsides to the prevailing wind velocity. One can best see what happens if the wire is mounted on the prongs of a vibrating tuning-fork. The effect is twofold. There is a general lowering of the resistance as though the wire were permanently cooled, and superposed on this general lowering is a ripple of resistance fluctuation. The amplitude of this ripple diminishes as the frequency of the oscillation increases until at very high frequencies the wire acquires a practically steady resistance, which, however, is lower than that which it assumes when stationary in still air. Of the casual fluctuations which take place in an exposed position out-of-doors or in a natural river in spate—the nearest approach to complete turbulence one can cite—the hot-wire detector pays undue attention to low frequency oscillations in the stream at the expense of the high frequency ones. It is the function of the compensating circuits to restore the balance as far as possible.

Finally in this connection, we may mention that the two instruments for recording turbulence and breakaway, viz. the Pitot head and the hot-wire, have been applied not only to models in the wind tunnel but to full-size aircraft in actual flight. A series of one or other of these two instruments is arranged over the upper surface of a wing, one behind the other, connected to a set of indicators which record continuously on a moving strip, while the pilot endeavours to stall the 'plane—of course, at sufficient height above the ground to allow plenty of room for recovery. The data so obtained are valuable adjuncts to wind-tunnel research into the nature of the instability of airflow which befalls when control of the aeroplane is jeopardised.

We have already mentioned the importance of the concept of the 'boundary layer' in determining when the breakaway shall take place. Some physicists speak of the 'local Reynolds' Number of the boundary layer,' and opine that critical conditions in the flow at a point on the model surface connote the accretion of a critical local Reynolds' Number. Of course, it is difficult if not impossible to specify the 'thickness of the boundary layer' for the purpose of stating a value for the

Reynolds' Number of the boundary layer; the most that one can say is that it is that height reckoned from the surface outwards in which the major drop in velocity from its external mid-stream value to zero at the solid boundary is experienced. Various devices have been tried to prevent or delay this secession of the boundary layer from the body. Besides the aforementioned suction or compression slots, whose purpose is to confine the depth of the boundary layer to small dimensions, we may keep down the local Reynolds' Number below the critical value by a suitable *increase* in the viscosity of the fluid within the layer, since this factor intervenes in the denominator of the expression. The obvious way to accomplish this in aeronautics is to heat the air in proximity to the model. This is tantamount to lubricating the surface in the same way that a fish's body is greased by the mucus which covers its scaly flanks, though there is no positive evidence that a fish glides faster through the water on that account.

The writer has carried out some experiments on the drag of some cylinders in a wind tunnel when they were heated internally by spiral coils carrying large electric currents. It was found that the drag of the hot cylinders remained low up to higher speeds than the cold ones, but that above a certain value of Reynolds' Number (calculated in terms of the diameter of the whole cylinder) the advantage was lost. It has also been found that flexible bodies whose surfaces are given a sinuous motion like that of a flag or a fish can under certain conditions experience less resistance than a corresponding rigid one. The subject of boundary layer manipulation by this or other means is, however, in the experimental stage, and more must be done both on the physical and mathematical sides before one can say whether such manipulation is profitable.

We may conclude this rapid survey of the place of physics in aeronautics by drawing attention to a number of special types of aircraft which have evolved out of a study on the part of their inventors of the application of physical precepts to the science of flight. In the last chapter we described an experi-

mental ship in which the place of the conventional sails was taken by a pair of rotating cylinders. This—the Magnus effect—has likewise been tried on aeroplanes. The rotor has usually an appendage in the form of a streamlined tail mounted on the same frame as the cylinder but fixed to it, the rotor and appendage together forming a wing. To a certain extent the presence of the tail diminishes the lift that one can derive from the Magnus effect, but since it reduces the drag by an even greater amount below that of the cylinder without fin, the

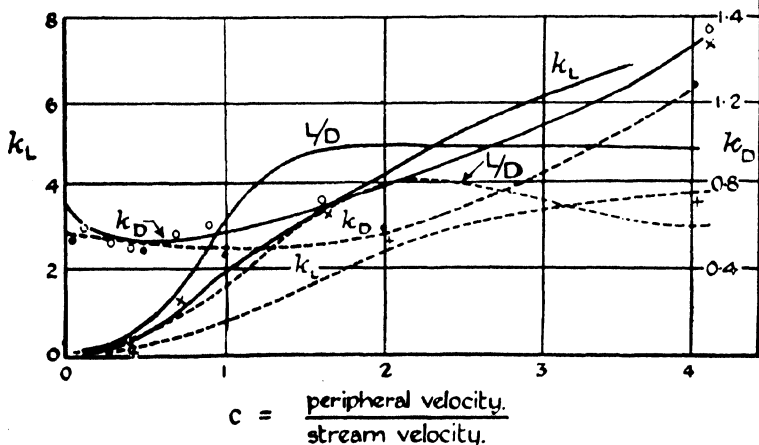

FIG. 11.—LIFT AND DRAG COEFFICIENTS ( $k_L$  and  $k_D$ ) AND LIFT/DRAG RATIO FOR A ROTATING CYLINDER IN A STEADY WIND; DOTTED LINES WITHOUT AND FULL LINES WITH END DISCS

sacrifice of some of the lift is generally considered worth while. Fig. 11 shows the lift ( $k_L$ ) and drag ( $k_D$ ) coefficients for a circular cylinder at various speeds of rotation relative to the steady wind, together with the resulting lift/drag curve. Considerable enhancement of the lift is obtainable as the rotor speeds up, but one must remember to take into account the energy used by the engine in turning the cylinder before one compares the efficiency of this aerofoil with one of the same shape but with immobile parts of orthodox design. An experimental aeroplane fitted with such wings was built in

Germany a few years ago, but, as far as the writer knows, the results of its trials were never published. There are probably not a few constructional difficulties to be overcome before the device can safely be appropriated to general practice even if its efficiency should satisfy its engineering and commercial sponsors.

An apparatus to rise vertically from the ground is known as a helicopter, but no such arrangement has yet been perfected. The principal reason for this is that an airscrew does not function in a stagnant or limited supply of air with reasonable efficiency, so that when set with its axis vertical a short distance above the ground in the manner that most designers of such machines have chosen, it merely creates large whirling motions of the air without making any upward progress; or if it does succeed in lifting the craft to which it is attached from the ground, the latter merely performs a few inelegant and unsteady hops. More hopeful is a design for an aeroplane with the usual forward-acting propeller, but having the wings replaced by a large slow-running airscrew with its axis set nearly vertical.

This is the principle of the auto-gyro invented by the late Señor M. da Cierva. The large airscrew possesses such a considerable inertia and presents, too, such an effective area of lifting surface when in rotation, that the auto-gyro offers two outstanding distinctions to the fixed wing aircraft. In the first place it can rise from and return to the ground at a very steep angle (something like a bee settling on a flower), and secondly, it shows no tendency to stall at these steep angles of climb. Hence it is at its best when required to land on or take off from a very small field and in training a learner. Perhaps the easiest way to regard its flight in a horizontal path is to visualise it as continually tending to fall through the air and so setting the large windmill in motion, whereupon the motion of the sails acts as a brake to prevent its falling farther. The pilot counteracts the falling tendency by driving the machine forward with the propeller. As the axis of the 'windmill' is set back slightly from the vertical, this forward

motion brings into play a draught which has a component acting along the axis of the supporting airscrew and keeping it in rotation. If the machine climbs, this rate of revolution should diminish; on the contrary when it sinks. But the inertia of the huge blades is too considerable to allow of a sudden stall at either extreme.

When taking off from the ground, the large screw must first be set in operation and then the machine 'taxies' under its propeller along the ground until the horizontal blades have sufficient impetus to lift the aeroplane off the ground, the speed of rotation increasing as the aeroplane accelerates for the reason just given. In the early auto-gyros the preliminary rotation was obtained by groundsmen pulling on a rope round a pulley on the windmill axis, but now the starting up is usually carried out by the engines working through suitable gearing.

The blades of the supporting airscrew are not fixed rigidly to their axle as is the case with a conventional propeller screw, for the following reason. As the blade comes forward its velocity relative to the wind is greater than when it recedes; consequently the lift on the advancing blade is greater than that on the recessional blade on the opposite side of the axle, the maximum and minimum forces occurring when the blades stick out perpendicular to the chassis axis of the aeroplane. If the blades were fixed to their axle, this alternating rise and fall in lift would cause an unpleasant rocking of the craft, or, at the very least, an ungainly list to one side. By setting them on the boss so that they are free to move in a vertical plane, the varying lift on them can make them flap up and down slightly as they go round, while leaving the chassis on an even keel. Actually, there is a lag between this lift and the position taken up by the wing so that the wing tip does not reach its highest position in the orbit until it is pointing straight ahead and its lowest when it is pointing directly astern. This flapping can be seen if one watches an auto-gyro in flight from the side or on photographs taken from such an angle. It is then apparent as a tilting back of the 'disc' of the airscrew from its normal position at right angles to the axle.

This aspect of the auto-gyro brings us to consider the problem of flapping flight in the usual sense of the word, i.e. an imitation of the flight of a bird. Up to the present this problem has remained insoluble by man, although it was the natural method for him to copy. Until recently, no progress has been made beyond a series of catastrophes, of which the origin is to be found in the legendary exploits of Icarus. Even in these enlightened times there are not wanting fanatics who will risk their lives in emulation of the Icarus exploit, without preliminary experiment or calculation. The niceties of control required for flapping flight baffle the experimenter, though, of course, they are instinctive in the young bird. There have, nevertheless, been some wind-tunnel tests on aerofoils which either moved up and down in rhythmic motion or had a sinuous movement passed along their flanks after the manner of locomotion of fishes. Actually the former arrangement does give an increase of lift in certain circumstances over that to be gained from the corresponding aerofoil when held steady in the wind. The effect is named after its discoverer, Katzmayr. As the aerofoil moves up and down the angle of incidence of the relative wind on it varies; indeed, the same effect may be got by fixing an axis through the centre of the aerofoil and oscillating it to and fro through a small angle instead of lifting it bodily up and down, so letting the air attack it now at a larger, now at a smaller angle. In terms of our Fig. 9 we may imagine the aerofoil taken through a cycle of lift/drag values, say from an angle of incidence of 5 to one of 10 degrees about the mean value 7.5 degrees. Now although the lift is actually varying, yet the average value is for most aerofoils greater than that of a steady aerofoil kept at a position corresponding to the angle 7.5, and the same thing is probably true of the bird's wing. The Katzmayr effect has never, so far as the writer knows, been applied to full-scale aircraft owing to engineering difficulties, and it is doubtful, even if these were overcome, whether its efficiency would warrant such application. It has, however, been cited to explain why certain aeroplanes appeared to gain efficiency when the fabric on the wing became accident-

ally loose and so free to oscillate. Naturally this condition was contrary to safety regulations and the fabric was forthwith made taut again with recovery of the former (less advantageous, so it was alleged) lift and drag.

The only other excursion into the mysteries of flapping flight of which the author knows consists of some tests of a machine recently made in the Chalais-Meudon wind tunnel for complete aeroplanes. This freak has two pairs of slowly flapping wings fixed to the chassis in tandem, one pair being up while the other is down, and looks from the front like a monstrous insect resuscitated from the neolithic age. Results of the tests are not yet published.

Although not the last word in aeroplane design, the successful aeroplane in the last Schneider Trophy Race, which we have chosen for our illustration (Fig. 12, Plate I) as companion to the streamlined locomotive, probably represents nearly perfection in the application of streamlining to aircraft.

#### SOURCES

- M. da Cierva: "Auto-gyro" (J. Aero. Soc., **30**, 8, 1926).  
 Lockwood Marsh and E. C. Vivian: "History of Aeronautics," 1920.  
 E. Ower: "Measurement of Air Flow," 1933.  
 N. A. V. Piercy: "Aerodynamics," 1937.  
 N. A. V. Piercy and E. G. Richardson: "Flow of Air adjacent to an Aerofoil" (Aero. Res. Comm. R. & M. **1224**, 1928).  
 E. F. Relf: "Compressed Air Tunnel at the National Physical Laboratory" (J. Aero. Soc., **30**, 20, 1935).  
 E. G. Richardson: "Flow of Air adjacent to a Rotating Cylinder in a Stream" (Aero. Res. Comm. R. & M. **1368**, 1930).  
 — "Recent Model Experiments in Aerodynamics" (J. Aero. Soc., **31**, 810, 1927).  
 — "Manipulation of the Boundary Layer" (J. Aero. Soc., **42**, 816, 1938).

#### JOURNALS

Journ. Aero. Soc.; Journ. Aero. Science (Amer.); Aircraft Eng.; Reports and Memoranda of Aero. Research Comm.; Technical Reports of National Aero. Research Coun. (Amer.).

## COMMUNICATION PHYSICS

THE earliest signalling over a distance was by beacon fires. Readers of Carlyle will remember his vivid description of the chain of beacons which announced the sighting of the Armada. Though these beacons are no longer fired except at coronations and jubilees, they have left their marks upon the ordnance survey maps in the frequent occurrence of the name Beacon Hill between London and the South Coast. Later a system of semaphores took the place of the beacons over routes which required frequent messages, such as that between the Court and the Naval Dockyards at Portsmouth and Plymouth. There are still Telegraph Hills in the South of England. In their heyday, before the coming of electricity, this system could transmit a signal from London to Portsmouth in 15 minutes. Visual signalling still holds its own on the railway. In the early years of the railway age it was a copy of the semaphore or flag telegraph. It is rather surprising to reflect that a clever engineer like Brunel should have been so ignorant of physics—or perhaps one should say of the British climate—as to equip what is now part of the Great Western Railway with signals working on the fashion of a roller blind; a red square of material was exposed for ‘danger’ and rolled up for ‘line clear.’ The wind soon disposed of these. About the same time the familiar board type of semaphore was introduced and has remained standard practice on British and Colonial lines, save that nowadays the semaphore is more often inclined upwards than down for ‘go ahead.’ This upward deflection has an advantage over the old ‘nodding,’ which again finds its explanation in meteorological physics, viz. that the weight of snow resting on the upper edge of the board cannot cause an erroneous indication of ‘line clear.’ In fact, an accident

at Abbots Ripton in the closing years of the last century was attributed to snow setting the signals at clear. As a result of the inquiry into this, the former Great Northern Railway introduced a semaphore balanced at its centre of gravity, which earned the name of 'somersault signal' and of which not a few are still to be found on the L.N.E.R. system south of Doncaster. Another company seems not yet to have learnt this simple lesson in physics, for, curiously enough, the Castlecary accident in 1936, at which a driver failed to receive warning of a stationary train in front of him, was attributed to snow having set a distant signal in the off position. On the French railways, another signal, less susceptible to interference on the part of nature, became standard. This was the disc signal, a coloured board which presents its broadside to the driver for 'danger' and is set edge-on for 'line clear.' The signal is more definitive, in that the two settings are given unequivocally, whereas sagging of the wire connecting the semaphore to the cabin may make the indication uncertain, if the board merely gives a passing nod to the driver. Miniature disc signals are used in this country to indicate the position of points. The railwaymen call them, for some obscure reason, "Tommy Dodds."

The introduction of red and green flags and lights first drew the attention of industrial psychologists to the defect of colour blindness. Since the railway companies demanded that their operating staff should be free from this affliction a body was set up to inquire into the tests which should be made to determine to what extent a man suffered from colour blindness. Some interesting variations in colour vision were found and the affliction proved to be more common than had heretofore been suspected, for the reason that such a person learns from intercourse with his fellows what colours to associate with common sights such as trees and sunsets, but is at a loss when confronted with a colour without context, such as a coloured token. One guard who was completely colour blind but never made a mistake with his flags was found to have a secret notch cut in the red one for its identification! Others who could

not name a green or red flag when it was presented alone could distinguish them when side by side, one apparently seeming a darker shade of grey than the other. Nowadays tests of sight and hearing are routine for recruits to the railway service, since they will probably spend a lifetime therein, though it was of less importance in the early days when the personnel was both casual and impermanent; witness poor Bramwell Brontë's brief employment as booking clerk at Bank Foot Station on the Lancashire and Yorkshire Railway.

The test of colour blindness is usually carried out on the Eldridge-Green apparatus, consisting of a lantern in front of which tinted glasses are exposed in succession. These the candidate has to identify. It is also possible to dilute the primary colours of the spectrum with various amounts of whiteness or blackness to see if this affects the ease of identification. If the subject mistakes a red for a green, or either of these for white or grey, he is usually rejected out of hand. Other rarer cases suffer from a falling off in sensitivity at one end of the spectrum, especially the red end, resulting in difficulty in separating purple from crimson. Unless this defect is serious, it does not result in the candidate's rejection from the signalling service. Similar tests are applied to would-be signallers in the Navy.

The electric telegraph followed close on the heels of Oersted's and Ampère's famous experiments on the deflection of magnetic needles by the action of an electric current passing through a neighbouring coil. With a single needle, three indications were possible: zero, leftward deflection, and rightward deflection on reversal of the current. This led to its use by the railways for the block system of telegraphing the passage of an impending train from one signal cabin to the next. The three positions of the needle then stand for: 'line clear,' 'train accepted,' 'train on line,' and are worked in conjunction with an electric bell for audible warning. The bells for the 'up' and 'down' lines have different pitch. The necessity in Post Office messages of getting more indications than these three led to official adoption of the Morse code, whereby the dots and

dashes making up the alphabetical signals were transmitted as deflections of the needle to left and right respectively. Before this became established a number of weird and wonderful systems for giving each letter a separate indication appeared. Some of these involved successive movements of the needle by steps round a dial until it stopped at one of the twenty-six letters marked on the dial, something in the fashion of a barrel typewriter. Others had fearsome arrays of needles, each operated by a separate circuit, so arranged that one set pair pointed to a letter on a diamond frame. A number of these relics can be seen in scientific museums.

The telephone originated only about sixty years ago. It was the invention of Graham Bell, who conceived the idea of turning the mechanical vibrations of a steel diaphragm into electrical ones in the telephone line and back again into mechanical vibrations in the receiving end of the system. Actually, the telephone no more than the telegraph necessitates the intervention of an electric current, at least over short distances. A telephone can be rigged up by stretching a wire between the vertices of two taut cones of bladder. On speaking into one trumpet, the sound can be heard in the other. Presumably the flexural vibrations of the bladders are transformed to and from longitudinal sound waves in the wire.

The original sender for the electric telephone worked on a different principle from the receiver. The electric current from a voltaic battery was varied in intensity through the intermediary of a loose carbon resistance. A thin steel diaphragm was stretched across a capsule containing granules of carbon. As the diaphragm vibrated under the action of the voice it shook up and so altered the resistance of the carbon in series with the battery that pulsations of the current in synchronism with the voice passed along the wire to the far end, where they traversed a miniature electro-magnet mounted under another steel diaphragm. This thereupon emitted sound waves which were a more or less faithful replica of the voice at the sending end.

Edison replaced the carbon microphone with an electro-

magnetic sender identical with Bell's receiver. The telephone then no longer required a battery, for the sender transformed acoustic into induced electric waves in the line which were retransformed into sound waves in the receiver. Yet another type of sender-receiver was invented about the same time, though it was not used extensively until years later. This was the condenser microphone in which an electric condenser was set up between the vibrating diaphragm and the back wall of the metal case, which was in turn connected to the line. Transient changes in the electrical capacity of the condenser initiated by changes in the separation of the plates as the diaphragm responded to the voice caused surges of electric charge along the line which in turn set up corresponding changes in the attractions of the plates in the condenser of identical pattern housed in the receiver. The condenser transmitter gives better distortion-free reproduction of the initial sound, but because its sensitivity is much lower than that of the carbon transmitter, it had to await the invention of the thermionic valve amplifier to overcome this deficiency. It is now used whenever exact measurement of sound intensity or close reproduction of sound waves is demanded in the laboratory.

The telephone remained a fashionable toy for short-distance transmission for some years after its inception. Attempts to use it over greater space intervals, however, soon disclosed one of the fundamental stumbling-blocks to long-distance telephony, i.e. that of the attenuation of the signals, and the variation of attenuation with frequency which produces distortion of the speech. The latter weakness is not so damaging to telegraphic communication, and the early attempts at tele-messages confined themselves to the Morse code. A submarine cable was laid across the English Channel in 1851, and later, after much loss of cable, between Valencia and Newfoundland under the Atlantic Ocean, through which it became possible to send signals which could deflect a sensitive mirror galvanometer. (This mirror galvanometer was, in fact, devised by Lord Kelvin for this very purpose, though nowadays it is more familiar in physical laboratories than in

the offices of cable companies.) In those days, before valve amplifiers were known, the feeble current would have been insufficient to operate a telephone receiver even had the distortion of speech sounds introduced by such a long line not rendered the intelligibility nil. The current along such a cable does not reach the further end instantaneously but travels at a definite velocity. If a sinusoidal variation of electric potential is applied to one end, a damped wave passes along the cable so that at every point there is an oscillation of potential copying the initial one but having a smaller amplitude and with a lag of phase becoming progressively greater along the cable the farther the point from the sending end. The rate of attenuation naturally depends on the resistance of the cable per mile, but both the damping factor and the velocity of propagation depend on the distribution of inductance and capacity along the cable, and even a simple copper wire possesses a certain modicum of both these factors. The armoured submarine cable having a gutta-percha and hemp insulation between the copper cable and the metal sheath is, in fact, a long condenser of coaxial plates in a gutta-percha sheath, 'earthed' on the outside through the conducting sea-water. The damping factor becomes greater as the frequency of the sine wave goes up. This latter point is less important in telegraphy than in the transmission of speech, but it does limit the rate at which the 'dot-dash' variation of potential can be applied at the sending station if the signal is to be clearly perceived at the remote end and not to become a meaningless and more or less continuous blurr. It was Kelvin again who realised that the line must be treated as a condenser, charged and discharged at each application of potential and that the capacity limited the rate at which Morse signals could be applied to the system. Before this, an Atlantic cable had been ruined by engineers who thought that all they had to do to get a detectable signal through was to apply a sufficiently high potential at one end. It is the rate at which messages can be sent through rather than the power which must be considered in regard to successful transmission.

But since the sounds of speech are made up of various admixtures of sine waves—forming the vowels—and of stopping and starting noises—forming the consonants, it becomes important that this attenuation shall be diminished or, at any rate, evened out for all those frequencies which govern the intelligibility of speech. This was accomplished by the French engineer Pupin, who invented the loaded line. A Pupin line has inductances set along it at regular intervals, or—in later modifications—inductance uniformly loaded along it, between the cable and the earth or sea, whichever is the local habitation of ‘zero potential.’ By this means the damping may be made uniform for all sine waves up to a limiting frequency which can be set fairly high in the treble so that in practice all speech sounds except those characterised by high frequency components such as the *s* sound may pass through a long line without becoming unrecognisable. Pupin at the same time showed how to construct an ‘artificial line’ consisting of a series of lumped inductances and capacities which can simulate the transmission of a real cable yet take up much less space.

Artificial lines are valuable for both teaching and testing purposes, since a complete trunk cable can be built up by sections in a small laboratory. These shadow lines are also used in duplex telegraphy, that is, the sending of simultaneous messages in opposite directions along one and the same pair of cables. It again rests on the fundamental wave theory of transmission along cables. If along two parallel cables of different characteristics and therefore different phase velocities, sine waves are being propagated, there will be places where waves in the nearby cables are in phase, and others where they are in dead opposition of phase. A suitable current measuring instrument connected across the two cables will record the signal at the ‘in-phase’ points but be deaf to the message when tapped across ‘out-of-phase’ points. If we so send the waves that each pair of ends are out of phase with regard to sending but in phase with regard to arriving signals, both sending and receiving can be carried on simultaneously, thus doubling the

usefulness of the line. In practice, the earth is used for the return circuit so that the second 'shadow cable' consists of a stratum of soil to which is appended an artificial line at either end. This, in conjunction with the real cable, can then be used for two-way signalling. An extension of the system enables several pairs of subscribers to use the same telephone cable, though not all simultaneously.

We have said that there is a limit to the pitch at which sine waves are transmitted without abnormal degradation. Above a certain frequency, in fact, the loaded line rapidly becomes opaque to signals. We find the same effect in mechanical analogues of the loaded line. A stretched string loaded by equal weights at regular intervals forms a good analogue to the electric cable loaded by inductances, the mechanical inertia of the masses taking the place of the electrical inductance of the coils. If one end of such a string is oscillated to and fro after the manner of a person sending waves along a rope, it will be found that the system shows a marked preference to transmitting the low frequencies of agitation. If the end is vibrated sufficiently fast, little except an uncouth and erratic disturbance will reach the far end, provided the string is long enough to allow the inertia of the masses to exert their full influence; whereas at a low frequency waves pass to the far end and are reflected without let or hindrance. It is, in fact, a 'low pass filter.' All such filters must comprise a fairly large number of elements—whether of mass, inductance, or capacity—for their operation to be effective, since the mathematical formulæ on which their design is based apply, strictly speaking, to an 'infinite line.'

In the acoustical sphere we find similar devices. The air in an orifice or embouchure of a pipe supplies inertance (mostly), while that in a reservoir or nearly closed cavity acts as a spring, the acoustical analogue of the electrical condenser, whose size determines its capacity. Thus a low pass acoustic filter can be made out of a long tube with equidistant side holes, like a never-ending flute. If a telephone or loud-speaker transmitter be applied to one end and supplied with

alternating current of rising frequency, while the listener puts his ear to the far end, he will notice a marked fall in the amplitude of the sound signals above a certain critical frequency. The threshold value depends on the size and spacing of the side holes. The cut-off is never so sharp as in the corresponding electrical filter, because every acoustic 'inertance' carries with it a certain amount of ineradicable 'capacity' and vice versa. Such filters have occasionally been tried between the tone arm and horn of gramophones to remove the scratch noise of the needle, which is of high pitch. Of course, such an expedient removes the same part of the gamut from the whole of the reproduced music. It is usually easier, if electrical pick-up is used, to take the offending sound out of the electrical waves before reconverting them to sound waves in the loud-speaker. It remains to remark that high pass, band pass, and band reject filters can be constructed both in the electrical and acoustic form by suitably reiterated arrangements of elements in the 'main line' and its 'branches.'

When distortion in the line has been corrected the troubles of the telephone engineer are not yet over. It is then necessary to check the conditions at the two ends. Do the transmitter and receiver—in which we must include the listener's ear—faithfully copy the speech sounds picked up by the system?

We have in an earlier chapter described the place which resonance plays in determining the response of a vibrating system to the forced vibrations impressed upon it. In microphones and telephone transmitters it is important that the response shall be uniform over as wide a range of speech frequencies as possible. If there are marked resonances to certain isolated frequencies, the sounds transmitted will be distorted, since any component in the voice which happens to fall with one of those resonances will be magnified out of proportion to the rest. A poor transmitter and receiver coupled to an uncorrected line can give but a poor imitation of the speech sounds injected into the line at the issuing station. To verify the trustworthiness of the transmitted signal, records may be made of the signal picked up on a good microphone

first when it is near the person speaking through the air directly and then after the same words have passed through the telephone line. Fig. 13 shows such records of the vowel 'a' before and after transmission, while Fig. 14 is a photograph of the microphone, amplifier, and cathode-ray oscillograph on which the records were made (Plate II).

We have already cited the condenser microphone as being one of the best of its class from the point of view of uniformity of response; it can be made to have this property for all frequencies between 20 and 5,000 cycles per second, but unfortunately it is not very sensitive. To get a more serviceable instrument it is better to make application of the electromagnetic principle and make up for non-linearity in the response by grouping the resonances throughout the scale, so that over that part of the range which is most important for the understanding of speech, i.e. between 150 and 3,000 cycles per second, no considerable hills and dales in the response characteristic curve exist. The levelling of the response curve can be done by the introduction of additional resonances, by shaping and adjusting the size of the capsule which carries the diaphragm, and by the shape of the throat and little conical horn which usually finishes off the mouthpiece. The natural frequencies of the diaphragm can be manipulated by grading its thickness from boss to edge. Incidentally, this fact was known in India long before the telephone era. Certain Indian drums were treated in the same way by enclosing iron filings between the drum skin and a dummy skin placed behind it in such a way that the effective thickness was greater in the centre than at the edges.

A fairly cheap transmitter which is finding favour, particularly for broadcasting, is the ribbon microphone. It requires a certain amount of amplification but has a good characteristic. The diaphragm consists of a very thin aluminium plate tightly stretched in the gap between the coils of an electric magnet in which it induces currents as it vibrates.

Owing to its tenuity and tautness, its fundamental frequency can be placed high in the treble and the response below made

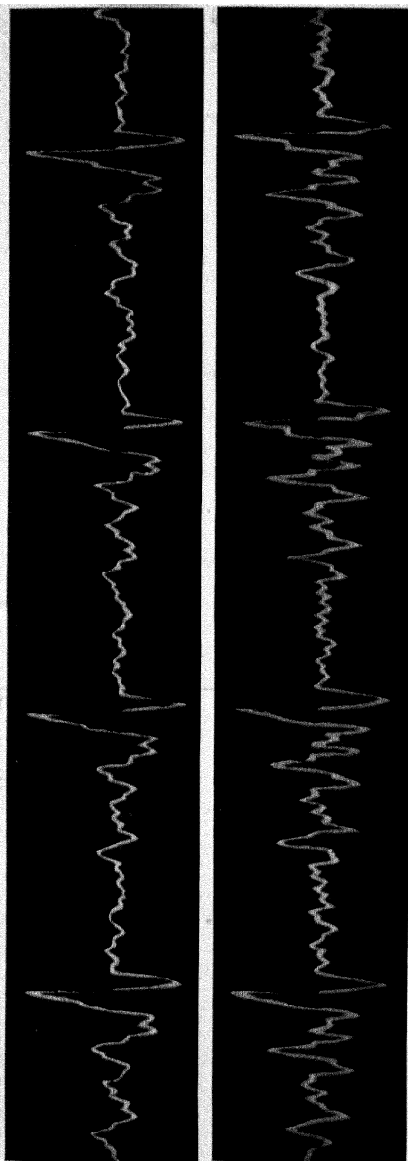

FIG. 13.—RECORDS OF SPEECH WAVE FORMS OF VOWEL *a* BEFORE AND AFTER TRANSMISSION THROUGH TELEPHONE LINE WITH DISTORTION

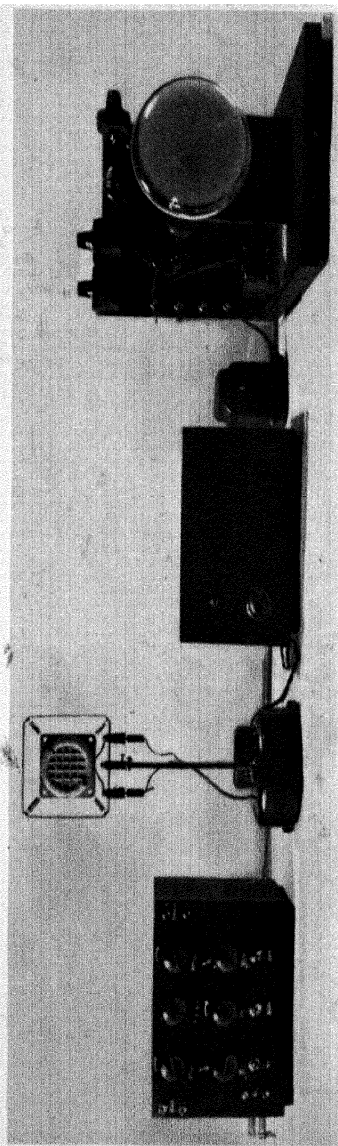

FIG. 14.—MICROPHONE AND CATHODE-RAY OSCILLOGRAPH RECORDING UNIT FOR TRANSMISSION CHARACTERISTICS OF SYSTEMS OF SPEECH COMMUNICATION



fairly uniform. It has another desideratum, though this is of more moment in broadcasting than in wire telephony, that it can pick up sounds from oblique directions, instead of merely in a straight ahead direction as most capsuled microphones do.

Even if one could build the ideal telephone system from the purely physical point of view, i.e. one in which each component received the same amplification whatever its frequency, this would not have solved the problem of communication from a distance, for we should have omitted one important constituent of human intercourse, the ear. The ear differs in several respects from a piece of physical apparatus. In some respects, indeed, it is superior to artificial receivers, but it also suffers from a number of 'defects,' regarded from the aspect of the telephone engineer. The most important point to be grasped is that loudness as judged by the ear is not the same as intensity of sound measured on a man-made instrument. This aspect was realised by the compilers of a scale of loudness when they made the decibel and the phon to be logarithmic units, and is also expressed in the Weber-Fechner law which says of the senses that as the stimulus (in this case, the sound intensity) increases according to a geometric progression the sensation (in this case, the loudness) rises in arithmetic progression. An electrical or mechanical detector such as we have in the physical laboratory will indicate the former, whereas aural judgment is based on the latter. If this law were exactly true under any circumstances and for any simple tone or conglomerate of tones, no matter what the pitch, the scale of loudness would go up by degrees proportional to the logarithm of the physical intensity of the sound.

Although as far as our present knowledge goes, the logarithmic or decibel scale is adequate for commercial purposes, it is by no means certain that it conforms precisely to the physiological and psychological facts. Look first at the difficulties which beset the investigator who attempts to measure loudness without recourse to a physical instrument. Who can say when one sound is exactly twice as loud as another? How far can such estimates agree, as between different listeners? Will the

answers be the same whether the listeners are trained to this type of response or not; whether they are fresh or tired; and whether the comparison tones are presented in slow alternation or in rapid succession?

A critical survey of the scope of such determinations was recently made by the staff of the Bell Telephone Laboratories in New York. The experiments in essence involve a subjective judgment of 'twice as loud.' The first set of experiments deal with monaural versus binaural hearing. If the observer having normal hearing hears a sound with one ear only and then with both ears, it is assumed that the effective loudness to him is doubled. If  $p_1$  represents the intensity heard with the one ear, and  $p_2$  is the intensity to which it is necessary to raise it before the loudness is the same as it is with both ears open, corresponding values of  $p_1$  and  $p_2$  for a number of persons are measured and the results plotted on a graph as circles on Fig. 15, A. In the second experiment a pure tone of frequency 1,000 cycles per second is sounded in sequence to a pure tone of another pitch at intensity  $p_1$  until both sound equally loud. They are then sounded together, and again it is assumed that the loudness is doubled. The reference tone is now raised to intensity  $p_2$  until it sounds as loud as the combination. Points so obtained appear as crosses on the figure. Finally the standard tone alone is sounded at pressure  $p_1$  and then at  $p_2$  so that it sounds twice as loud; these data (for three subjects) are also shown. The consistency of the results obtained by the three very different methods is considered to justify the construction of a loudness scale based on successive doubling. This has been done and exhibited on Fig. 15, B, where  $n$  indicates the number of times the loudness has been doubled, while  $p$  is the corresponding sound pressure recorded on a physical instrument. The scales of both the factors plotted have been reckoned logarithmically, and the fact that a straight line is obtained—at least over the range which matters in telephony and broadcasting—justifies the choice of the logarithmic scale of loudness.

Another factor with which we must reckon is the varying

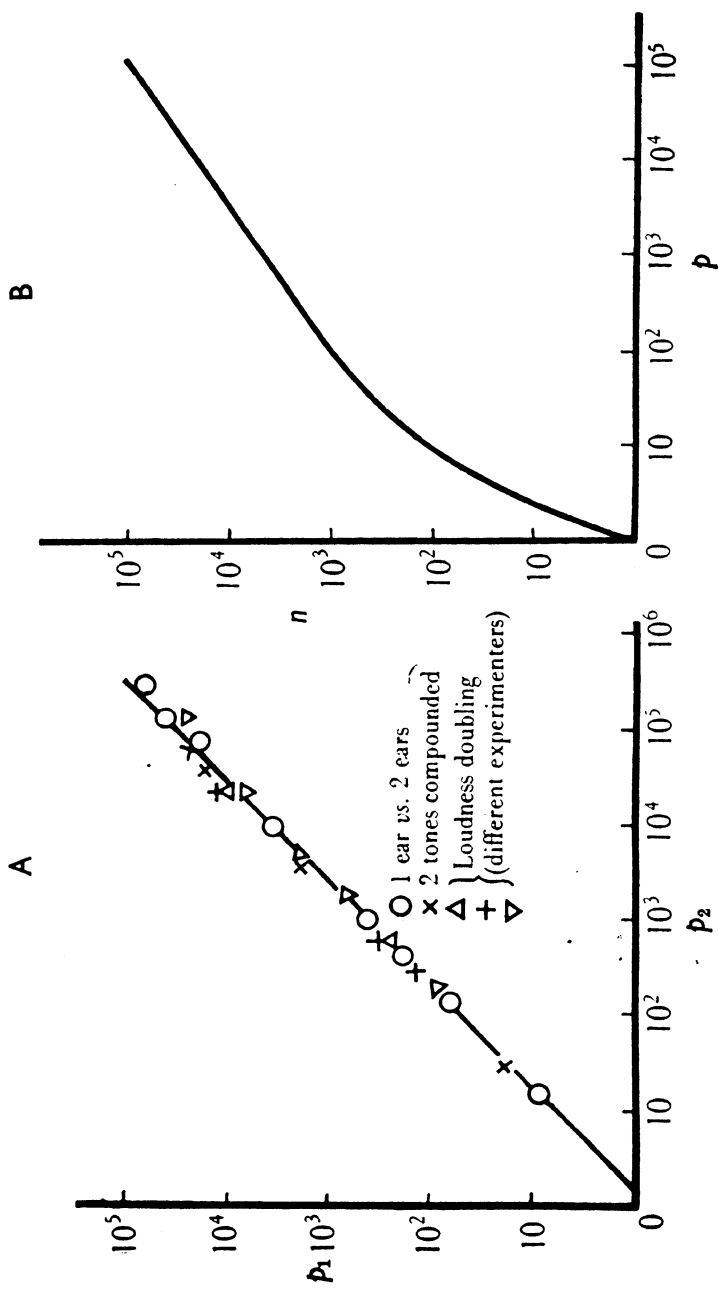

FIG. 15.—SCALES OF LOUDNESS (Fletcher)

sensitivity of the ear in different parts of the audible pitch range. The threshold of minimum audibility is lowest at about 1,000 cycles per second (hence, the choice of this frequency for reference tone) but rises on either side of it. This means that the ear is most sensitive to a tone of 1,000 cycles per second but less so if the pitch is higher or lower, since it takes a greater sound pressure to excite any sensation of hearing in the upper treble and in the bass. To a certain extent a variation of this nature is found in artificial receivers. At any rate, it is not difficult to make one which will simulate the ear in this respect. The falling off in sensitivity in the bass is the probable explanation of a significant experiment due to Dr. Harvey Fletcher. He found that if a complex note like that of an organ pipe having a low fundamental were presented to an auditor, listening through a telephone or loud-speaker, and the fundamental suddenly removed by means of filters in the amplifying circuits, the opinion was expressed that only the quality and not the pitch of the note had been altered by the change. Imagination evidently supplied the missing fundamental. At the time this conclusion was favourable to the makers of loud-speakers and gramophones who were not able adequately to represent the bass within the compass of a modern reproducing instrument.

While it is possible, with some practice, for an individual to evolve his own scale of loudness where a single and simple tone is concerned, it is another matter to estimate the relative loudness of two notes which differ markedly in timbre and pitch. When this has to be done the masking principle is employed. The sound whose loudness has to be estimated is presented to the listener at the same time as a pure tone of fixed frequency (usually the 1,000 cycle standard) whose intensity is gradually raised from minimum audibility. When the comparison tone is just audible above the other noise, the listener makes a sign. The procedure of the test is now reversed. Starting with the standard much louder, it is reduced in loudness until it is just masked by the constant noise. A meter now records the limiting intensity in terms of the minimum. If the meter has a

logarithmic scale, the level of the sound under test can be read off directly in phons.

There are a number of ways in which the masking test may be carried out. The two sounds may be presented simultaneously to both ears in the open, or one sound may be heard by an uncovered ear while the comparison tone is conveyed to the other ear through a telephone earpiece clamped to the head, so that this ear remains unaffected by extraneous sounds except in so far as a certain amount of conduction of sound takes place through the bones of the head. When this second method is used—and it corresponds more closely to conditions in actual telephoning than the first—the interference between the tones is less. Thus one can tolerate much more noise in the left ear, while listening to a message received in the right ear without the sense of message being masked than one can if message and undesired noise are mixed before reaching both ears together. The comparison tone is often produced from an electrically maintained tuning-fork in a sealed box, where the electrical energy is picked up by a coil, purified if need be by filters, amplified to a determined level by valve circuits, and fed to the ear capsule. In the final stage, the voltage applied to the earpiece coils is read on a meter, which can be calibrated to read the sound level directly in decibels. Such an apparatus is known as a noise meter. It was by means of such an apparatus that the table of noise levels quoted in the last chapter was drawn up.

Even if the physicist is not equipped with an electrically maintained standard of frequency and a sound-level meter, he can still estimate masking with a simple technique. All that is required is a 1,000-cycle pocket tuning-fork with a little clamp to compress the prongs placed between the jaws to a specified position, and a stop watch. While listening to the noise, the fork is held at a fixed distance from the ear, the clamp suddenly removed and the watch started. The fork commences to vibrate, but having no independent supply of energy, its amplitude begins to fall from the initial value on release at a constant rate, until it ceases to be audible above the other

noise, when the watch is stopped. The experiment is now repeated in the absence of the noise in question, preferably in a sound-proof room. The second recorded time will, of course, be longer than the first. Now it is a well-known fact about damped vibrations, that their amplitude falls off according to a logarithmic law, the same as that we are assuming for our scale of loudness. Thus the loudness of the fork drops by the same number of decibels for each second that it continues, reaching zero level at the instant it ceases to be audible in the quiet room. Therefore the difference between this time and the shorter one recorded while the noise was on is a measure of the loudness of the said noise, although the units of the operator's loudness scale will be arbitrary ones. Though the scale in this simple technique will not be an absolute one, it will be particular to that experimenter and his fork, which he can compare when he has the opportunity, with a calibrated noise-level meter. After a little training, he will find himself well equipped with this simple apparatus for the comparison of noise levels.

This principle of masking is an important one for the telephone engineer, since the operation of a telephone system is beset with many unwanted noises which seep in from external sources. These comprise noises picked up at the microphone due to inadequate sound insulation or complete lack of a kiosk to house the sender; noises reaching the disengaged ear of the person receiving the message, from similar causes; electromagnetic noises—currents induced in the line by the passage of currents along a neighbouring line. All these faults must be sedulously sorted out and eradicated if the line is to work well. The last-mentioned—'cross-talk effect'—is the most difficult to trace.

We have spoken of the necessity for adjusting the capacity and inductance of unit length of a telephone line, that is, giving it a characteristic impedance of such a value that it exercises no distortion on the signals transmitted, or perhaps, one should say more precisely, exerts the same distortion on all frequencies. In such a scheme the receiving apparatus must not be

neglected. Though we have discussed the effect of the shape of the sending and receiving capsules on their acoustic impedance, we ought not to overlook the external ear (*meatus*) itself since it forms part of the impedance at the receiving end. Fig. 16 shows an apparatus by which the impedance of the ear may be determined. C is a telephone unit working into a long tube T, terminating in an adjustable volume  $V_2$  (which communicates with T through the hole H) and the volume  $V_1$  formed between the rest of the tube and the ear drum D. The pressure on D is proportional to the current in the telephone C and its impedance. The total impedance of the system of tubes is mainly due to the combined effect of  $V_1$  and  $V_2$ . The impedance of the source may be expressed in terms of this and

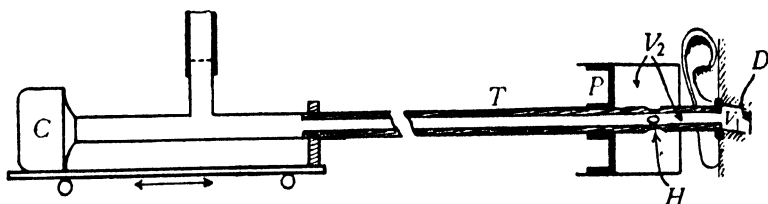

FIG. 16.—APPARATUS FOR MEASUREMENT OF IMPEDANCE OF EAR (*Sivian and White*)

the impedance of the ear drum, which is calculated in terms of the other pair. An alternating current of fixed frequency and amplitude is supplied to C and its impedance measured electrically while the volume  $V_2$  is made to assume a series of values in turn. From a series of experiments of this nature, the equivalent capacity and inductance of the ear are found.

There are certain other characteristics of the ear which we may mention although they do not affect ordinary telephony to an appreciable extent; but they are to be reckoned with when loud-speakers are used to radiate the message to a large audience. If the ear is subjected to great intensity of sound, intelligibility may disappear because the ear itself introduces adventitious sounds called 'subjective tones' since they are not present in the sound which strikes the ear drum and cannot therefore be picked up from the air by any physical resonators

or recording device. Such are the subjective combination tones, built up inside the ear as frequencies equal to the sum and difference of two simple tones loudly presented to the ear. Even if a single pure tone is presented at a sufficiently high sound level to the ear, it is accompanied when perceived by the brain with the octave and higher harmonics, superposed on the original by some inherent structure of the organ which causes it to distort sounds when overloaded, in the same way that some loud-speakers do. In order to estimate—for the purposes of measuring the intelligibility of messages—the extent to which a line is subject to noise interference, the practice has grown of conducting a series of standard articulation tests over the line. The operator at one end enunciates a series of meaningless syllables with pauses between them, while the listener at the other end writes them down to the best of his ability to understand them. Recently, the tendency has been to replace the nonsense syllables by a phrase-intelligibility test, short phrases having no connected context being read by the examiner at a specified rate. A great deal depends, of course, on the listener. A person who is familiar with and tolerant to one particular line is likely to stomach a higher degree of masking thereon than one who uses the telephone but rarely.

With the development of repeater circuits, listening on a trunk call may be less subject to interference than on a local line. This is because every time the signal is amplified, opportunity is taken to purify it. But there is now a different system in vogue for long-distance transmission; with or without wires. This consists in using a 'carrier wave' and modulating it with the audible signals in such a way that the audio frequency wave makes beats with the transmission wave after the fashion adopted for broadcast wireless telephony. The carrier frequency for the wire systems lies usually below 100,000 cycles per second, but a cable is now being made which can carry up to 1 million cycles per second without loss. Suppose now that a pure tone of 500 cycles per second is being sent along the wire. This will beat with the carrier current and give rise to sidebands having frequencies  $100,000 \pm 500$

and 100,000 — 500 respectively. At the receiving end these two combination tones of frequencies 100,500 and 99,500 cycles per second are dealt with in the same way as they would be in a wireless receiving set, that is, an oscillating valve circuit tuned to the carrier frequency experiences surges of amplitude up and down at the original rate of 500 per second, which in the earpiece reproduces a pure tone of this frequency, provided that overloading has not been permitted to distort. The advantage of this scheme over the old Bell system is that a number of carrier waves, each with its own modulated message, can be passed simultaneously along the same wire, and each picked up by an appropriately tuned oscillator which is deaf to the rest; just as the æther can be shared by a large number of broadcasting stations provided the frequencies of their carrier waves do not jostle each other too closely. The same limit circumscribes the wire and the broadcast systems, i.e. that the possible sidebands formed by beats with reasonable audio frequencies—say, up to 5,000 cycles per second—shall not overlap.

Naturally, a good deal of message telephony takes place through the intermediary of short æther waves radiated as beams across the sea from island to mainland and between distant countries.™ For these the virtue of secrecy cannot be claimed since it would be easy for an amateur having a short-wave receiver of the correct range and amplification situated in the path of the beam to tune in to the oncoming signal. This would not be the case if supersonic sources were employed to send a beam of (mechanical) high-frequency sound waves, either through the air (for short distances) or along a solid transmission channel, since the receptor would have to be a mechanical oscillator—piezo-electric or magneto-strictive—cut to the precise length to have a frequency exactly the same as the source. In other words, a variable tuning system would be impossible, since there is at present no means known of tuning piezo-electric quartz crystals or magneto-striction rods, short of removing them from the receiver and paring them down to raise their natural frequency. Listening to the message would

be virtually impossible for an eavesdropper who did not know the carrier frequency and had not provided himself with an oscillator of exactly this frequency. The audio-frequency message would be imposed on the supersonic carrier as in the corresponding electrical system. Patents for such supersonic communication have been taken out in the United States; although it is unlikely that the process will receive general adoption until considerable technical difficulties have been surmounted. It is suggested that it may find application in military and naval services.

#### SOURCES

- R. Appleyard: "Pioneers of Electrical Communication," 1930.  
 J. Mills: "Fugue in Cycles and Bels," 1936.  
 E. G. Richardson: "Acoustics of Telephony" (P.O. Tech. Publication **25**, 1935).  
 L. J. Sivian and S. D. White: "Measurement of Ear Impedance" (J. Acoust. Soc. Amer., **4**, 288, 1932).  
 M. G. Tweedie and T. S. Lascelles: "Modern Railway Signalling," 1929.  
 H. Fletcher: "Loudness" (J. Franklin Inst., **220**, 405, 1935).

#### JOURNALS

- J. P.O. Elect. Eng.; J. Acoust. Soc. (Amer.); Bell System Tech. J. (Amer.); Railway Signalling.

## CHAPTER V

# PHYSICS AND POTTERY

THE ceramic industries have evolved through centuries of more or less empirical methods to a high state of craftsmanship. In so far as they have sought the advice of pure science in this development, it has been mainly to the chemist that they have taken their problems. While chemistry plays a considerable part in the processes which take place during the firing and glazing of pottery, the writer thinks that there is still plenty of scope for physical research in the processes which precede the firing, i.e. in the preparation of the clay, its moulding and the earlier changes through which it passes in the drying and firing ovens, which are predominantly physical ones. This is now being recognised by the pottery trade, using these words to cover in a very general sense the marketing of all moulded articles whether of glass or of earthenware, and the manufacturer is not now content to take his materials without some information as to their composition and behaviour in the mould.

The substances which comprise the solid inorganic materials of the soil are of rather widely differing characteristics, at least to the eye, but, the author believes, are not so variable in chemical composition. A certain amount of calcium carbonate (under the forms of chalk or limestone) and silica comprises the bulk of the surface soils in this country, together with the oxides of aluminium, iron, calcium, magnesium, etc., to which the varying colour of the soil is mainly due. The mean particle size is perhaps the most important physical characteristic differentiating one specimen of soil from another. The subdivision of size can range from actual pebbles down to the minutest fragments of the abrasion of rocks, so fine as to float in permanent suspension in the atmosphere as dust.

As a rough calculation it is usual in pedology—the science which treats of the classification of soils—to call those particles with diameters between 2 and 0.2 mm. ‘coarse sand,’ those down to 0.02 mm. ‘fine sand,’ down to 0.002 mm. ‘silt,’ while all less than this last size are ‘clay.’ The names and divisions are, of course, quite arbitrary. (The micron is a convenient unit in which to measure the size of microscopic materials. Its value is one-thousandth part of a millimetre and its symbol  $\mu$ .) When a system contains discrete particles

(whether solid, liquid, or gaseous) finer than one micron distributed through a coarser structure, or in suspension in a fluid, it is called colloidal as opposed to homogeneous systems like air and water. So the fine clay fraction is often called the colloidal fraction, since it has these very fine particles within its structure conferring on it peculiar properties, of which more anon.

The best way to make the analysis in terms of the relative numbers or masses of particles comprised within narrow limits of diameter is to stir up the clay, deprived of any soluble or organic matter by successive washing with hydrogen peroxide in water or some other suitable liquid in a tall tank, and allow the particles to settle under gravity (Fig. 17). The settlement

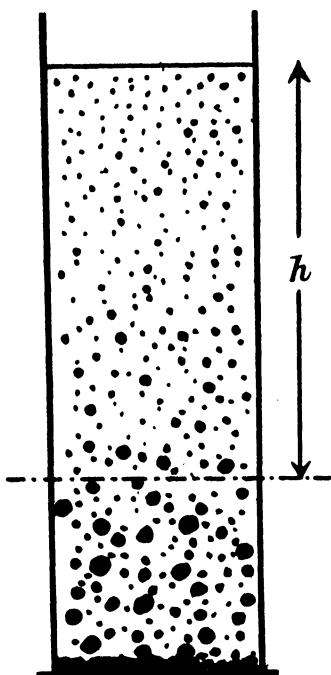

FIG. 17.—SEDIMENTATION OF A POLY-DISPERSE SYSTEM

takes place at a rate dependent on the difference between the specific gravity of the clay and that of the liquid directly and on the viscosity of the liquid inversely. It is not the same for all particles, varying directly as the square of their respec-

tive diameters; that is as their superficial areas if they can be assumed all to have the same shape. Thus at a given depth,  $h$ , below the surface of the liquid, if samples are taken at various times after the initial dispersion of the clay, the early samples will be fairly representative of the whole suspension; but as time goes on they will become progressively deficient in the larger particles which will have settled more quickly, until eventually samples will only contain those small enough to be supported permanently by their Brownian motion and unable to sink. Then if we take samples in water at  $17^{\circ}$  C. at a depth of 30 cm., soil particles of  $10\mu$  will be all clear past this point in 20 mins., those of half this size in 80 mins., etc., whereas all smaller than  $5\mu$  still remain in both samples with their original relative concentrations unchanged. Thus the difference between the weights of the two samples represents a decrease due to all particles between 10 and  $5\mu$ , and so on for the other sizes. (One can appreciate this more readily if one conceives a suspension containing *only* these two sizes. Then the top of the cloud of the  $10\mu$  individuals will be passing the observation post in 20 mins., thereafter a sample would contain always the same amount of the  $5\mu$  ones alone until 80 mins. had elapsed, when we should merely take up pure water.)

In the author's instrument, the sampling is done by means of a narrow horizontal beam of light traversing the tank at the required depth and falling on a photo-electric cell, coupled to a sensitive galvanometer. The photo-electric current at any instant gauges the amount of light which gets through the tank. At first the current is low, but as the heavy grains settle, the liquid begins to clear and the current gradually rises to approach its ultimate 'clear water' value. Before proceeding further it is essential to establish a relationship between the number and size of the particles and the light which they cut off. Provided the concentration is small—in practice, a one per cent. suspension is used—it has been found that the light extinguished is directly proportional to the surface area of the particles, at least for sizes down to one micron.

This is what one would expect if they acted as obstacles of a certain area each casting independent shadows on the photo-electric cell. The test in question was made by comparing the effects of continuously stirred suspensions of grains of uniform size, such as the spores of fungi, in the light beam.

Fig. 18 gives a sketch of the actual apparatus in the pattern marketed by Messrs. Gallenkamp, of London. The tank is about fifteen inches high and two inches broad. It is made of glass and blackened. Vertical strips of thin glass inside the tank prevent the measurements being upset by convection. The beam of light passes horizontally through a slit to the photo-electric cell, connected through a dry high-tension battery to a sensitive galvanometer which records the amount of light falling on the cell. The extent to which this current differs from that which passes when there is merely clear liquid in the cell is a measure of the 'weight' of the sample at the instant in question. The galvanometer is of the mirror type and may be arranged to show its deflections on a transparent scale, in which case the operator must note with the aid of a stop-watch the reading from time to time while the grains settle, or its deflections may be recorded continuously by a spot of light reflected from its mirror into a box camera having a film in motion through it at constant speed. The measurements are made without any of the interference to the sedimentation which results from introducing pipettes or hydrometers into the tank.

Two other features of the instrument may be noted. A small motor at the top of the case operates a stirrer to disperse the particles throughout the liquid evenly before a 'run' is commenced. The zero of time is reckoned from the instant that the stirrer stops. A thick plate of glass intervenes between lamp and tank which prevents heat-rays from the lamp getting into the liquid and setting up convection currents. Even so, when the apparatus has to be run for long periods at a stretch, it is necessary to enclose the whole thing in a thermostat and to take pains that the voltage across the lamp does not vary. When a large range of particle size in the specimen is antici-

pated, it is better to make the determination in two stages: first, in a fairly dense and viscous medium for the larger grains; second, in a light, less viscous liquid in which the smaller particles will sink fairly rapidly. This obviates the need for a thermostat.

For many commercial purposes a step-by-step method of performing this 'mechanical analysis' is desirable, but it is

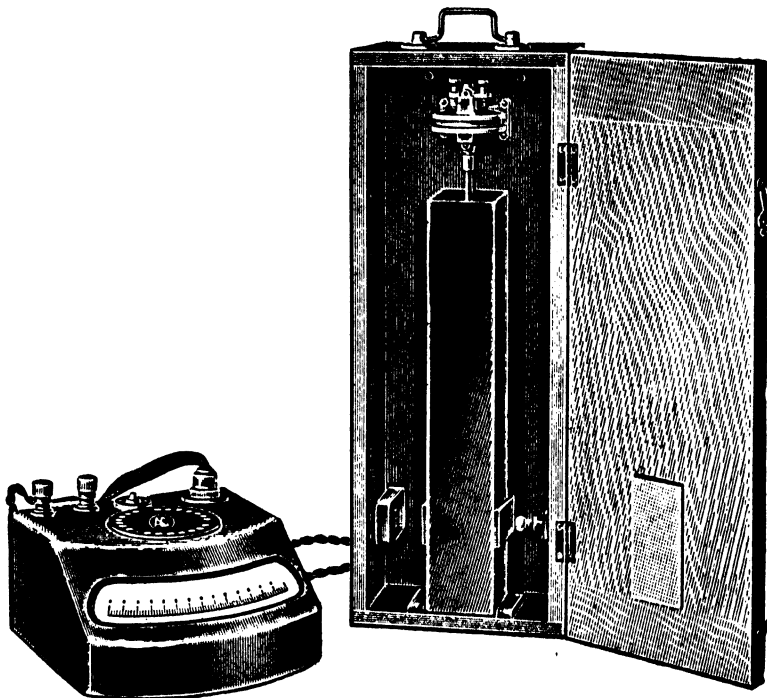

FIG. 18.—PHOTO-ELECTRIC PARTICLE SIZE METER (*Gallenkamp & Co.*)

possible from a continuous photo-electric record to derive an unbroken analysis of the specimen. This happens because the record is really a 'summation curve,' in the sense that the height of any ordinate corresponding to a certain time of sampling, i.e. to a certain particle size, represents the surface area of all particles *less than* that specific size. If one wants to get the 'distribution curve,' i.e. one giving the masses

of each size, one needs to draw a series of tangents to this curve and to plot them against the same abscissæ as before. This gives the distribution in respect of superficial area; to get that for relative mass we increase each ordinate in the ratio of the abscissa over which it stands, since mass or volume is proportional to superficial area multiplied by diameter. To return to our fictitious suspension of a soil having but two sizes: the photo-electric record of the summation curve for such a specimen would obviously be shaped like a short staircase with two steps, at the times when the two sets of grains were clearing the observation post. The distribution curve would contain nothing but two very sharp summits at the diameters corresponding to the risers of the steps. A typical summation curve with its corresponding distribution curve will be discussed in a later chapter (cf. Fig. 30, p. 126).

The author is now experimenting with an apparatus for detecting the smaller particles (less than  $3\mu$ ) in which the sedimentation is hastened by centrifuging, as in the well-known molecular weight apparatus of Prof. Svedberg. The whole apparatus with small tank, lamp, and cell will be whirled rapidly round, while leads to the galvanometer—the latter naturally steady—will be assured through the axis of the centrifuge and mercury ring contacts. In this way it should be possible to measure particles down to half a micron within a reasonable sedimentation time.

Beside the photo-electric method, the only other which can give a continuous record in the form of a summation curve is that of Oden, in which the solid gradually piles up on a balance pan hanging near the bottom of the tank in which settling is taking place. The increment in weight of the pan can be continuously recorded and gives the summation curve directly. It has, however, been found to be open to a serious error in that as the clay falls away from beneath the balance pan in the confined space between it and the floor of the tank, it leaves the liquid below the pan with an effective density less than that on top where there is a large concentration of clay particles. This reduces the buoyancy of the pan as time goes

on and makes the collected sediment appear heavier than it really is.

There is also another optical method, developed by the staff of Imperial Chemical Industries, which deserves mention on account of its extreme accuracy. In this the paths of falling particles are recorded as streaks on a photographic plate which is given a time exposure. The respective sizes can be identified by the lengths of the streaks on the photographic plate and counted. The author has been able to make comparisons of analyses of the same specimen in his own and in the I.C.I. method and has found good agreement, though he suspects that the I.C.I. method is more accurate. It has, however, the compensating disadvantages of expense, large operating space, and labour in measuring the considerable number of plates required for a single analysis.

For some purposes it is more convenient to use a photographic method to record the rate of settling, rather than to take continuous galvanometer readings. When this alternative is to be adopted, a smaller tank about four inches high is filled with the suspension and *the whole* placed in a parallel beam of light so that a shadow is cast on a photographic plate behind and an exposure made after a given time. The negative so obtained will appear black at the top but progressively clearer towards the bottom where less light has been able to penetrate. Now a narrow slit is set up in front of a source of light with the photo-electric cell on the other side of the slit. The plate is now passed slowly between the slit and the cell, galvanometer readings being taken every few millimetres. A resulting plot of photo-electric current against depth is of the familiar summation curve type and may be interpreted in the usual fashion.

Some of the most important physical properties of a clay paste are those which concern its behaviour under stress, since it has to undergo stress in the process of moulding, while other less concentrated forms under the name of slips are used for the glaze and are required to flow evenly over the casting, whereas the stiffer pastes used for the moulding process

must show plasticity and resist the stress to the extent of retaining their shape when moulded and not run away downhill. There are a number of ways by which one can study the behaviour of a lump of clay under stress. One of these is to put it into a cylinder provided with a hole and to extrude it by pressure on a piston introduced at the opposite end. If the original lump consisted of alternate layers of red and yellow clay, the extruded lump, cut in two down the centre along the axis, will show the pattern of flow under stress. For studying the behaviour of a clay paste under shearing stress it is enclosed in the space between a pair of coaxial cylinders, the outer of which is rotated at constant speed while

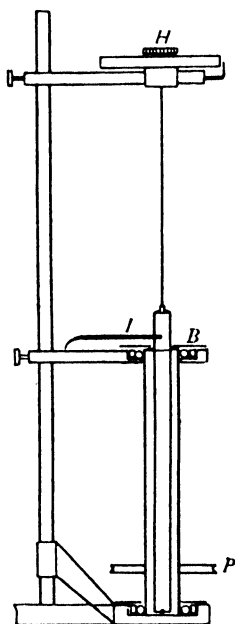

FIG. 19.—COAXIAL CYLINDER APPARATUS FOR SHEARING LIQUIDS AND PASTES

the resulting torque or twisting moment on the inner one, communicated through the clay paste, is measured. In this type of instrument the plug of clay is submitted to a simple shear, that is to say, that while the inside of the mass is held stationary, the outside is moved parallel to itself. Of course, this is not the only type of stress to which the clay may be submitted in filling the mould or applying the slip, but it is one of the simplest known to physics, which is sufficient reason for choosing it as representative. Actually, experiments in which other kinds of deforming stresses have been employed lead to similar results, so that we are not losing generality by fixing our attention on this one.

The apparatus used by the author for the purpose is shown in Fig. 19. The main support of the apparatus is a vertical steel rod carrying three carefully aligned horizontal brackets. Two of these, the lower ones, contain the ball bearings in which the outer cylinder rotates.

This is worked from an electric motor through the pulley P. The upper bracket holds the torsion head H, from which is suspended by a copper wire the inner cylinder. The latter carries a pointer I which stands over a horizontal circular scale fixed to the middle bracket. To prevent the inner cylinder from leaving its central position, the disc B serving as dust cover for the central bearing has a hole which just clears it and a poppet at the bottom protrudes into a somewhat larger hole in the centre of the base of the outer cylinder.

When in use the inner cylinder must ride clear of these guides, but if it should accidentally engage them, warning is given by a sudden change in the torque readings. As with all instruments of this type, there is an 'end effect' at the base, which must be allowed for if absolute measurements of viscosity are required. This is generally done by taking readings with two different volumes of the liquid under observation.

The torque on the inner cylinder when the outer is rotating at constant speed can be measured in two ways, viz.: (a) by the movement of the pointer over the circular scale, or (b) counterbalancing this twist by turning the torsion head until the pointer is brought back to zero. For absolute measurements, the torque required to produce unit twist on the inner rod must be found by applying a small couple to it. If a homogeneous liquid such as paraffin were put in the apparatus, the law connecting the torque on the inner cylinder with the speed of the outer cylinder would be found to be direct proportionality, for such a liquid has a viscosity independent of the applied shear, which means that the strain on it (shown by the torque on the inner cylinder) is always proportional to the applied stress (in this case represented by the speed of revolution of the outer cylinder) (Fig. 20). On plotting torque against rate of revolution of the outer, the slope of the resulting straight line is a measure of the viscosity of the enclosed liquid. But a clay paste possesses plasticity and cohesion in the sense that a critical stress must be applied before any motion takes place and that thereafter the strain does not increase uniformly with the shear. This one can see from the curves of Fig. 21

for a number of mixtures of clay and water, the percentage of solid matter being attached to each curve, together with the critical stress (C.S.) for initiating motion. For the thinnest slip (one part clay to three of water) used, motion started at once and the fluid behaved nearly as a pure oil would, but with

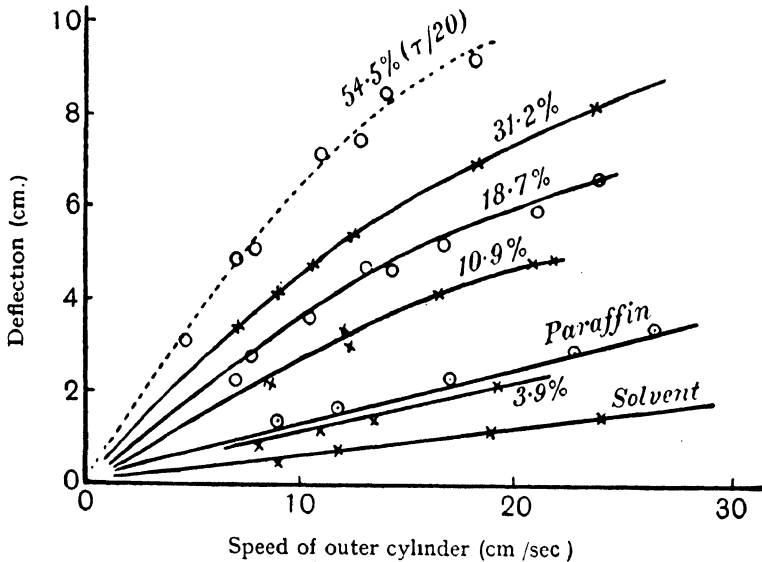

FIG. 20.—TORQUE: RATE OF SHEAR CURVES FOR PURE LIQUIDS AND CLAY PASTES

increasing concentration, a rise in the critical stress to produce motion appeared, and a decreasing viscosity—shown by the curve turning over to the horizontal—as the rate of revolution of the outer cylinder increased. The occurrence of a critical stress is, of course, a necessity if the stuff is to stay put when cast. It will be further noticed that there are kinks in the curves at low speeds. This instability is evidently due to a breakdown of the quasi-solid friction which subsists at low rates of shear and the commencement (at a lower torque value) of suspensoid flow. The break occurs at about the same velocity of the outer cylinder at every concentration, but when the inner rod is replaced by one of half the diameter it happens at a proportionally lower speed. It may be added that the kink in

the curves is only shown during an *increase* of the stress; as the outer cylinder slows down, the torque results follow the dotted curve and progress steadily towards zero.

There are therefore three stages in the flow as the paste is

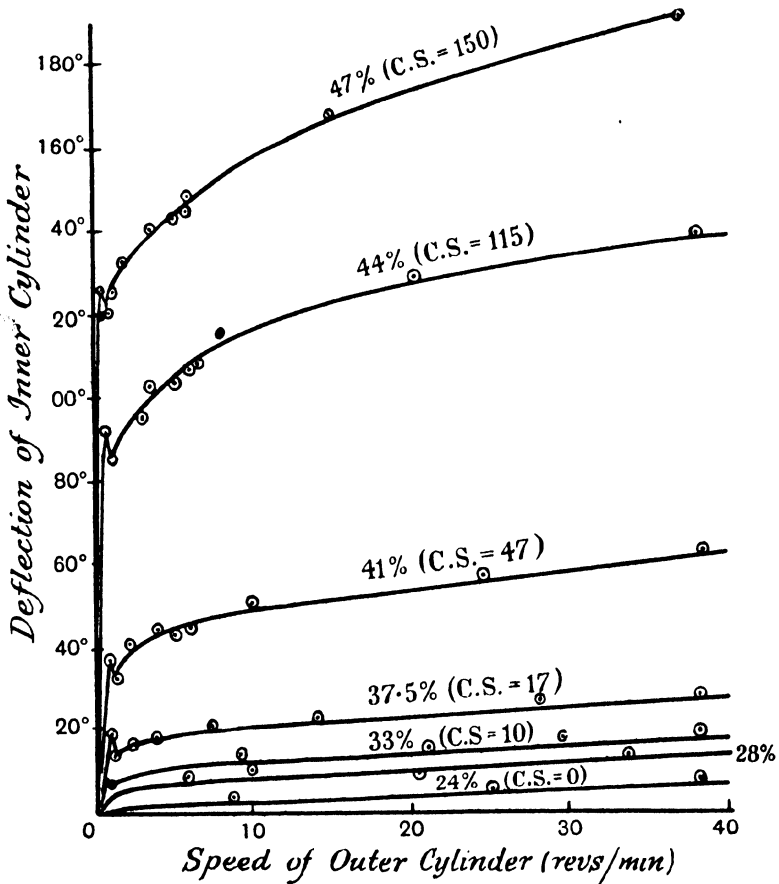

FIG. 21.—RIGIDITY AND CRITICAL STRESS OF CLAY PASTES

stressed: (a) rigid resistance, during which the material behaves largely as though it were an unyielding solid; (b) quasi-solid friction, in which the substance 'gives' under the action of the stress until the latter becomes more than it can bear without rupture, whereupon it slips back something like

a violin string under the action of the bow; (c) viscous flow during which it behaves like a liquid, except that the viscosity diminishes as the rate of shear increases, a behaviour typical of colloidal flow.

A closer insight into the flow characteristic of a clay paste is to be had if one measures the velocity from point to point across the annular space between the cylinders, since the viscosity is a function of the velocity gradient. In the apparatus constructed by Dr. E. Tyler and the author, the change in the electrical resistance of a thin platinum wire is used to measure the velocity of the fluid past it. The actual apparatus is shown in Fig. 22. The hot-wire W, 1.5 cm. long, is carried vertically on the ends of two fine needles inserted through ebonite bushes in the outer brass cylinder which is rotated through the pulley P below. Electrical connection to the fork blades is assured by dippers working in the fixed annular rings of mercury GG mounted on the case of the instrument. The speed of this cylinder is observed by means of a neon lamp N illuminating the stroboscopic disc D, and the flashing of the lamp is controlled by a standard tuning-fork. The hot-wire can be traversed across the space between the two cylinders by turning the micrometer head M. The torque communicated to the inner cylinder is taken up by the suspension wire (not shown in the drawing) in the same way as in the former apparatus. With the outer cylinder revolving at constant speed, measurements of the resistance of the wire at various points across the paste-filled space are made and converted into velocities by the use of the previously obtained calibration curve. Fig. 23 shows gradients in a fifty per cent. paste. Each curve refers to a different speed of outer cylinder. In the stiff paste, the whole mass moves with the same angular velocity as the outer cylinder, except for a thin ring near the inner one, wherein most of the shearing effect is felt. This plug-like flow is typical of pasty substances. If the paste is removed and a pure oil put in its place the angular velocity increases steadily from the inner to the outer cylinder (broken line). It is then possible by mathematical analysis to obtain

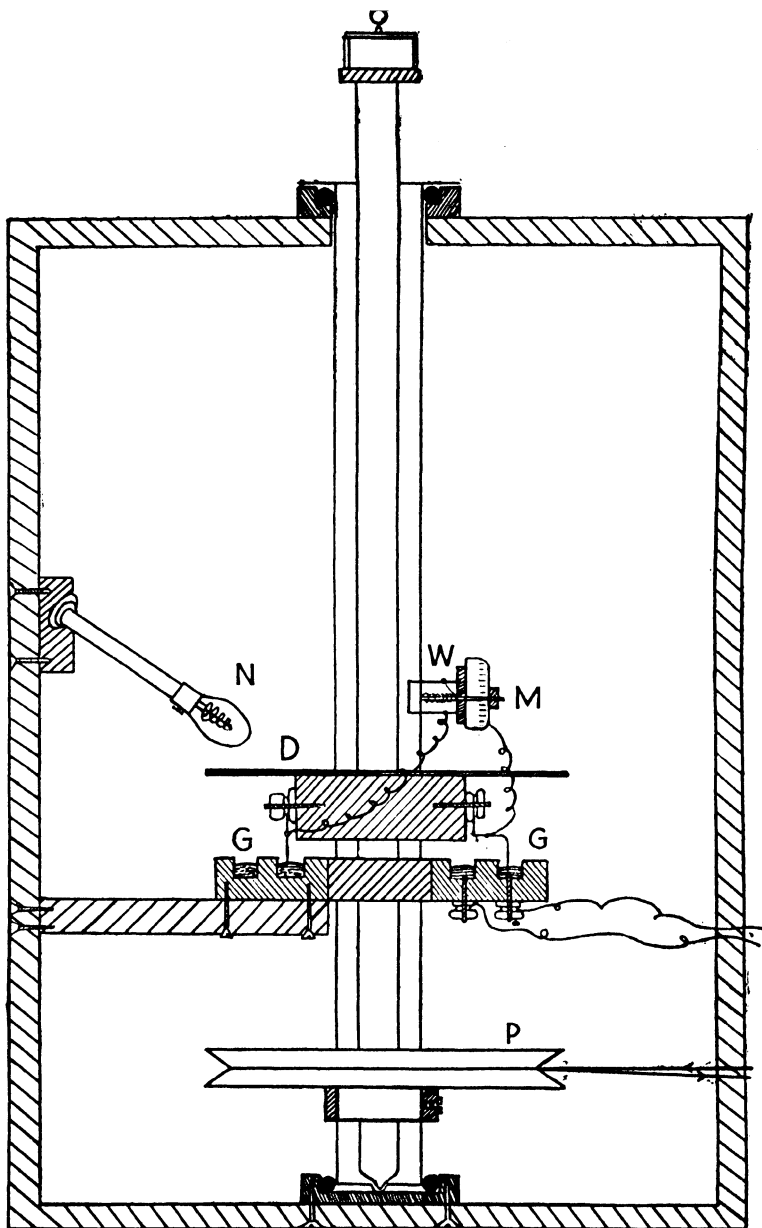

FIG. 22.—CONCENTRIC CYLINDER APPARATUS WITH HOT-WIRE ATTACHMENT FOR MEASURING VELOCITY GRADIENTS (*Richardson and Tyler*)

data from Fig. 23 relating viscosity to velocity gradient for the paste. They show that as the rate of shear (or velocity gradient) increases, the viscosity falls asymptotically towards

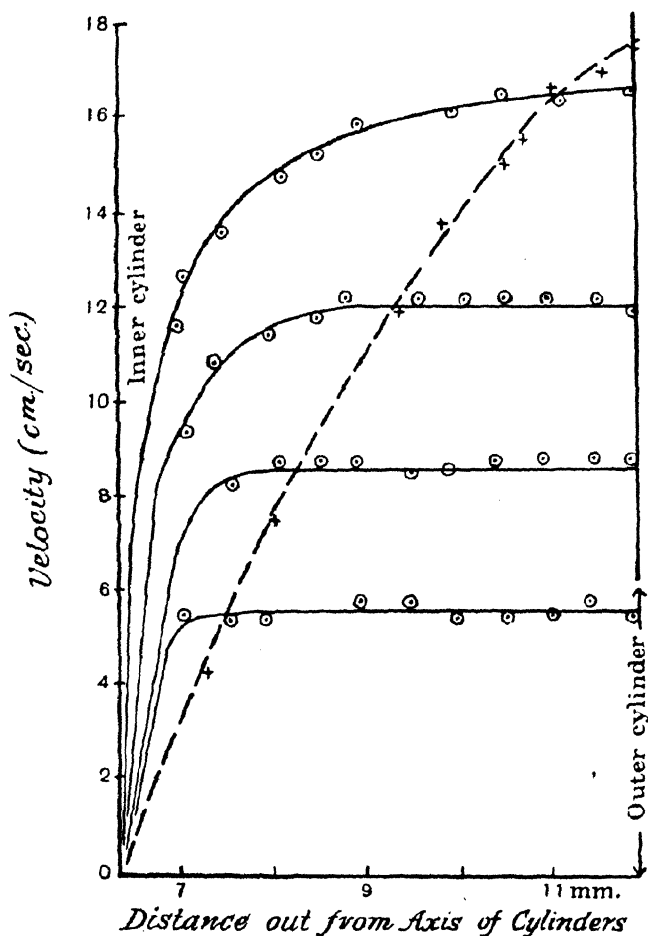

FIG. 23.—VELOCITY GRADIENTS AT VARIOUS SPEEDS OF OUTER CYLINDER IN CLAY PASTE; BROKEN LINE SHOWS GRADIENT IN PURE SOLVENT

that of the solvent, and that over a large part of the range covered by the experiments the viscosity is proportional to an inverse power of the gradient of velocity, which varies from one-half to one as the liquid proportion is reduced.

The rigidity which a clay slip exhibits when a small shearing stress is applied to it means that the paste possesses a considerable amount of cohesion as well as plasticity. It is generally believed that the small colloidal particles in the clay are the binding influence, and that their attractions are gradually overcome as the rate of shear is intensified, hence the greater mobility shown at high rates of shear. (The mobility can be measured by the slope of the rate of flow: stress curves; in a pure liquid this would be the reciprocal of the viscosity.) The critical stress required to initiate flow in a stiff semi-solid paste not only helps it to take a moulding, but makes it resist tearing in the way that a dry non-colloidal clay could not do. These two properties are still more apparent when oil is used as a binder, as in the modelling clay called Plasticine. Oil, of course, is only of use as binder for temporary casts and is of no use in ceramics. A ceramic should have a reasonably high critical stress after enough liquid has been added to give it sufficient mobility for working. A less plastic clay can be made to have the same critical stress by using a smaller quantity of water, but it would then be too stiff to work; on the other hand, if one tried to give it the desired mobility by extra water, the critical stress would fall off, resulting in inability to retain shape after casting. For equal water contents, china clay has the lowest and ball clay the highest critical stress.

The part that particle size plays in the plastic deformation of the clay and in the resulting product of the kiln is still a matter for research. Generally speaking, we find that the pastes containing the finer particles exhibit more cohesion and rigidity and so adapt themselves to the mould more perfectly. But it is impossible to generalise since wide differences in behaviour are shown to varying stresses and in different concentrations. The fact remains that from long experience the ceramic industries have learnt to keep the finest china clay such as is especially found in parts of Worcestershire for porcelain, Cornish clay for ordinary glazed pottery, the coarser clays for earthenware and brick making, the average granular-

ity of the clays increasing in that order. For the clay 'slips' used to supply the glaze, when suitably baked, again a fine clay is desirable in order to provide a smooth finish, a coarser clay resulting in a rough speckled finish occasionally used for special effects. Now that accurate methods of measuring particle size are available, doubtless further work will be done on the undoubted influence which it has on the quality and strength of the ware it produces.

Other physical problems arise when the ware is dried and fired. It is not easy, in spite of the use of up-to-date instruments for measuring temperature (pyrometers and the like), to secure uniformity of temperature in the kiln. Even if this desideratum could be secured, it would not be a guarantee of the casts being uniformly baked. Water evaporates from the surface and new supplies of moisture diffuse from the interior towards the surface. This makes the material contract more on the outer layers than in the interior and strains are set up leading to the opening of fissures. The only cure for this is a very slow rate of drying, and this is economically unsound. One way of preventing losses by cracking is to bake the ware in an atmosphere whose humidity is fairly high, so as to slow down the rate of evaporation from the surface to correspond more closely with the diffusion of moisture from the interior of the mass towards the exterior. Analogous strains may be set up in the firing, so that the designer must avoid certain shapes and thicknesses of pottery which would favour the formation of cracks. The degree of firing is often tested by the overseer sounding the ware by hammering to see whether it gives out a good resonant ring. Both the velocity of sound and the amount of damping in a material change with its elastic properties, so that sounding it with a hammer from time to time is an indication of structural change. The sonority depends, too, on the chemical constitution, so that it is not safe to say of two bricks made of different materials that the one that rings better or gives the higher pitch is necessarily of better quality.

In glazing, when, as often happens, the clay slip is painted

on the vessel beforehand and they are then fired together, the coefficients of thermal expansion of the glaze and the body must closely approximate, otherwise the glaze will peel off or run into blobs according as it expands less or more than the vessel beneath. Since part of the clay of the body may pass into solution or suspension in the glaze when the latter melts, a mere determination of their separate rates of expansion is not enough.

The physicist is also called upon to effect the removal of impurities from the clay slip, like iron and copper filings or grains of the ores of these materials, found naturally with the clay, which if allowed to remain would cause blemishes. Iron filings can be removed by magnets in the puddling machines, but the removal of other mineral fragments is not an easy matter.

The insulation of high-temperature plant, like furnaces and kilns, against loss of heat is a matter to which the potter must direct his attention if he is to avoid large running costs. The usual form which the insulation takes is a brick of specially low conductivity and the use of special mortars for jointing of similar properties. Insulating concrete is used for foundations and furnace doors, and insulating powders for filling in hollow spaces. Though low conductivity must be the prime consideration in the choice of material, ability to stand stresses must not be overlooked. Another point is that furnaces have to be reconstructed at fairly frequent intervals, and therefore the proportion of dismantled bricks which can be used again should have an influence on the grade selected. There are other bricks known as refractories which have to stand the great heat developed inside the furnace without cracking. These must not be confused with the outer bricks whose function is to conserve heat.

Over the top of the kiln there will also be an arch of refractory and insulating bricks which, if well arranged, can reduce the temperature of the outside of the top of the furnace to such a low degree that a coating of bitumen can be put over it for weather protection. The effect of wind on such surfaces will

be greater as the temperature of the outer walls is allowed to rise. This gives an added impetus to the desire of the manufacturer to provide low conducting walls, since these can take up a steep gradient of temperature whereby the outside is raised but a few degrees above that of the air.

The crying need in this direction is a material which combines insulating and refractory properties with as much mechanical strength as possible. A considerable amount of research work has already been carried out to this end, both in Britain and in America, but its development is still in its infancy. In the end a compromise has to be made. For a good refractory one requires a close texture; for a bad conductor one wants rather porous properties or at any rate low density. The size and disposition of the pores are also important at high temperatures.

One of the petty annoyances which beset the person who attempts to make a casting by compressing a plastic substance into a mould, whether by heat treatment as in pottery or by cold or chemical action as in metal casting, is to prevent during the process the formation of bubbles of gas which remain hidden within the structure and cause weakness or, as happens at times in the kilns, come to the surface and remain embedded in the glaze, spoiling the appearance and, if present in sufficient numbers, giving the ware a rough-cast finish; in fact, vitiating the purpose of the glaze. If the gas has been produced during the firing, it is difficult to suggest a remedy; if, on the other hand, the bubbles have been occluded in the clay slip during the action of puddling and have been turned out of the mass by heat, it is possible to remove the dissolved air by agitation.

To effect this, the potter might well take a leaf out of the book of the metal worker, who has lately been using with some success supersonic agitation to de-gas the melt prior to its being poured into the mould. When these high-frequency mechanical vibrations were first produced by piezo-electric quartz oscillators working beneath oil—put there primarily to preserve the electrical insulation—it was soon noticed that any gas dissolved in the oil was rapidly driven out by intense high-

frequency agitation. If the molten metal is allowed to pass over the upper electrode of the oscillator while it is in action, any gas within the mass is driven out as bubbles to a greater extent than is possible by the application of low-frequency agitation or any other known process. The resulting cast on setting is free from brittleness or weakness due to hidden gas bubbles which, set free in the cooling, have been unable to reach the surface. A similar remedy could probably be employed in the ceramic industry, although it would certainly prove expensive if it had to be applied to every clay-mixing machine. An experimental equipment would show whether the saving in defective casts warranted the initial expense. Once that has been got over, the running costs of these supersonic sets is quite low, as they use quite a small amount of electric power compared to an industrial machine employing electric motors.

#### SOURCES

E. Bourry: "Treatise on Ceramic Industries," 1920.

J. S. F. Gard: "Thermal Insulation in Clay Industry" (Trans. Ceramic Soc., **38**, 401, 1939).

E. Hatschek: "Viscosity of Liquids," Chap. XII, 1928.

E. S. Hedges: "Colloids," 1931.

E. G. Richardson: "Physical Properties of Clays" (Trans. Ceramic Soc., **38**, 359, 1939).

#### JOURNALS

Trans. Ceramic Soc.; Trans. Amer. Ceramic Soc.; British Clayworker; Sands, Clays and Minerals.

## CHAPTER VI

# PHYSICS AND THE CULINARY ARTS

EVEN if we set aside problems of food preservation and refrigeration, there is still much that physics can say in regard to the preparation of foodstuffs for the palate. Here again chemistry has been first in the field, though as a chemist dabbling in the kitchen is looked at askance by the epicure, his work is not bruited abroad by the food trade. The physicist, on the other hand, is not so regarded, or at any rate is looked upon as harmless when he appears disguised in chef's clothing, and there is a great deal of physics in cookery, though it is not generally recognised as such.

We will start with cereal physics and see what physics has to do with the manufacture of the staff of life. Let us briefly run through the processes to which the grain is submitted. It must first be ground in a mill to a sufficient degree of fineness; then mixed with water to form dough; yeast or baking powder is added so that by fermentation or chemical action a gas is liberated to lighten the structure; follows the baking.

Flour consists largely of starch granules, interspersed with fat in the form of gluten. The fat content has an important influence on the physical properties of the dough formed from the flour, as we shall see. While it is known that the mean particle size of the starch grains determines the type of bread or cake in the end, its exact influence on the properties of the dough is only now becoming a subject for research. Empirically, the flour is divided into two principal grades, bread flour and cake flour, the former having the coarser particles, while the latter, being finer, has usually been ground for a longer period. On the average the particles range in size from 125 to 5 microns, the smaller ones having been removed by the

winnowing action of currents of air in the mill. The type of wheat also influences granularity. For instance, flour made from Irish wheat, being softer, is less granular. The strong imported Canadian flours have more of the finer grains in their texture than home-milled flours. A study of granularity at different stages in the grinding is very useful to the miller, as it enables him to assess the efficacy of the various processes and sieves. It can also be used to compare the output of two millers working on samples of the same flour.

In order to measure granularity we may use the photo-electric apparatus described in the preceding chapter, save that water cannot be used for the liquid in which sedimentation takes place, as it causes the starch grains to swell. Further, the specific gravity of flour is much less than that of clay, so that, even if there were no swelling, the smaller particles would take an inordinately long time to settle. A number of liquids have been tried, mostly mineral oils. These probably dissolve the fat in the flour, but that the removal of the fat does not alter the rate of settling of the starch grains has been proved by taking a specimen of flour and extracting all the fat by a solvent which is drawn off by suction. The results of a subsequent mechanical analysis tally with a previous one on the untreated specimen. It is usual to make the analysis of flour in two parts: one in petrol for the fine particles and another in palatinol or a mixture of carbon tetrachloride and paraffin oil for the larger granules.

During the mixing of flour and water, the mass acquires a plastic structure as the gluten imbibes up to one hundred and fifty per cent. water and is dispersed among the starch granules. If the amount of water added to the flour is insufficient, the mix becomes lumpy. The energy used in the electric mixing machines now commonly used is an indication of the efficiency of the mixing process. The work done on the dough (indicated by the electric current taken by the machine) at first rises for several minutes and thereafter falls until it reaches a level value. The rise is attributed to the formation of a gel (*vide infra*) by the gluten and water and the fall to some break-

down of the colloidal structure. The mixing is usually completed in about ten minutes. In making comparative tests of flours by their behaviour in the machine, it is difficult to ensure that all receive the same treatment and so to standardise the mixing process that data of this type are comparable. Dough is plastic, but it should also be to a certain extent elastic, that is, it should recover on being stretched or compressed and then released. This test the baker can make in some measure by feeling the dough in his fingers; but since this method of test is a subjective one, it is preferable to use a physical apparatus for a purely physical property.

There are a number of forms of extensometer or compression meter suited to this task, which bring out the peculiar nature of dough very well. In one instrument a length of dough

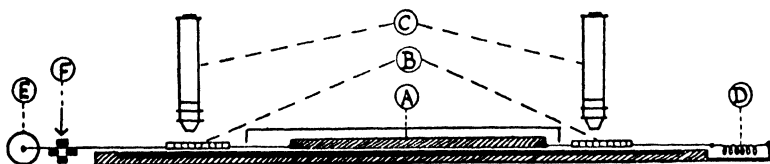

FIG. 24.—APPARATUS FOR RECORDING EXTENSION OF DOUGH (*Halton and Scott-Blair*)

about one centimetre thick by ten centimetres in length is forced out of a gun in the shape of a little syringe on to a pool of mercury in a trough. Incidentally, the elasticity of the substance is well seen in the way that it swells out after leaving the nozzle of the gun, which needs to have a diameter only half that of the extruded piece. When the specimen has been forced out, metal caps are deftly fixed to each end and each cap has attached to it a light spring whose extension can be read on paper scales B, fixed to the sides of the trough (Fig. 24). The end of one spring D is fixed while the other passes over a peg E, which can be twisted in order to tighten up this spring—violin fashion—and the increase in the spring's length acts as a measure of the stress applied to the dough. The difference in reading through the microscopes, C, of the pointers attached to the caps on the scale gives the new length of the baton of dough,

so that the strain on it (in this case the extension) can be determined. This is the apparatus used by Halton and Scott-Blair in their work on the plasticity of dough.

The author uses the simpler apparatus shown in Fig. 25. Here it is a compression which is applied to the dough. A vertical cylinder about one inch diameter and six inches long

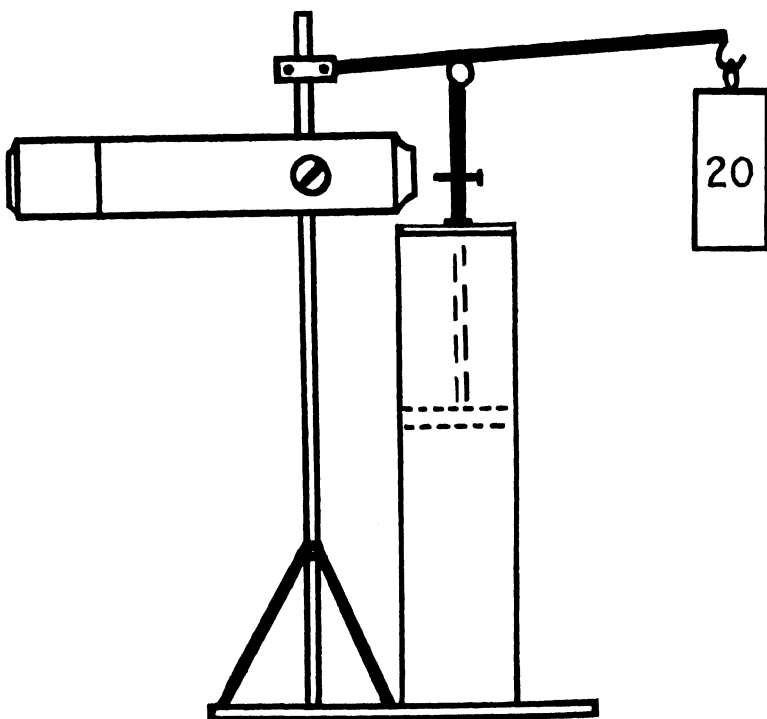

FIG. 25.—APPARATUS FOR RECORDING COMPRESSION OF DOUGH AND CLAY

is filled with the plastic material to be examined, care being taken to see that no air is occluded in the mass. The same precaution is observed when the rubber-washed piston is applied. The piston rod carries a pin, the head of which can be observed through a vertically travelling microscope of low power. The course of events in this apparatus is similar to that in the dilatometer already described, except that, of course, in this one the application of sufficient stress causes a diminution

of size, while in the former the application of tension causes an extension. A load of about twenty pounds is put on the arm and the motion of the mark on the piston followed up with the microscope, the operator taking readings at a quick succession of time intervals. At first the motion is rapid, but after a few minutes there is little further movement. The load is now suddenly removed by a tripping action and the dough relaxes, the extension being again followed with the microscope. Recovery is rapid at first but afterwards slows down. If the

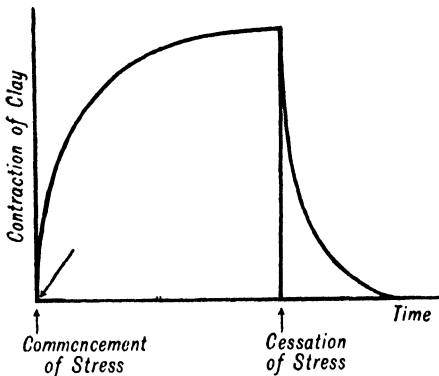

FIG. 26.—STRAIN AND RELAXATION OF PLASTIC SUBSTANCE

material is perfectly elastic, it will recover its original size. The difference between any two substances which possess different degrees of plasticity is simply that of shapes and areas of the strain and relaxation curves. Fig. 26 shows a typical pair of curves. (Results for clay and dough differ principally in the mag-

nitude of the stress required to produce a given strain and in the time taken to relax.)

Too much extension will cause the baton to break. While the possession of great tensile strength (resistance to rupture on extension) is not a matter of first importance in dough as such, there are other food processes in which it is desirable that the preparation should possess it. In making some kinds of toffee, for example, before cooking strands of the confection are pulled and interwoven by a machine which secures adequate blending and working of the ingredients. This process would fail were the mix to break up easily into lumps. Similar considerations apply to the uniform spreading of honey on bread if lumpiness is to be avoided.

The plasticity and elasticity are of fundamental importance

in the rising of the dough after the ferment is added. The two pieces of apparatus just described are not so well adapted to investigations of these properties during the rising as that of Chopin. In this apparatus a thin pat of dough closes one end of a cylinder into which air is blown at a constant rate so that a bubble is blown with the material of the dough. The bubble may be blown until it bursts and the pressure change inside it recorded during the process, or the pressure may be released at a moderate value and the dough allowed to relax. The usual indication of this instrument is rather like the curves obtained with the compression meter. At first the pressure rises rapidly, then more slowly as the dough begins to yield, and the bubble swells until finally it swells faster than the influx of air. During this stage the pressure inside the bubble falls. The pressure at the point of rupture is a measure of the tensile strength of the dough film. The whole area between the pressure curve and the time axis is a measure of the work done on the pat of dough. The more elastic it is, the less work has to be done on it. To a certain extent, then, measurements on the Chopin machine link up with those on the compression meter and on kneading machines in which the work done is continuously recorded. In all cases the general shape of the curves is the same, as we have already remarked.

It should be added that rubber, clay, and even metals show analogous behaviour under stress, but the latter require much greater stresses and show a proportionately smaller change of size. It is doubtless the cellular structure of rubber and dough which causes them to give way to comparatively small tensions. When a soft metal such as aluminium is being extruded from a die with the object of forming a thin wire, it does in fact show the same elastic swelling which we have remarked when dough is extruded from a syringe; but whereas flour demands pressures of the order of ten pounds per square inch, the metal may need a force of some tons per square inch.

When dough is made to flow in this manner, in what way, then, does the flow differ from that of a true liquid or from a

clay paste? The difference is only one of degree. Clerk-Maxwell many years ago sought to express the viscosity of a substance as the product of its elasticity and a period of time which he called the relaxation time. An ordinary liquid is difficult to compress; that is the same as saying that it has a high degree of elasticity. But the time of relaxation is immeasurably short, so that the product of the two is a finite and usually small quantity. If a substance has a moderate viscosity, it may be that it has a small elasticity and a large time of relaxation or a small relaxation time and a large amount of elasticity. The former would be the case with a dough specimen which exhibited a long flowing slope in the compression and relaxation parts of its characteristic curves (in any of the three types of apparatus described above) but no considerable maximum. The latter type of dough would show a rapid rise and fall to and from a sharp peak.

Halton and Scott-Blair consider that the time of relaxation of the dough is characteristic of its structure and should therefore act as a measure of the quality of the flour (for bread-making purposes) from which it is made. Unfortunately, both it and the viscosity vary with the applied stress on a given specimen, so that if this criterion were generally adopted, it would be necessary to specify the conditions under which the measurement was to be made. Good bread-making quality is associated with a high viscosity and a low elasticity, i.e. a long period of relaxation. The low elasticity of the gluten makes it easily deformable so that the rise is large and a big loaf results. If the relaxation is small on the other hand, the dough may collapse during the rising process.

During the baking process, watch has to be kept on temperature and humidity. The baker talks of 'baking strength,' but this is a concept impossible to express in physical quantities. The present practice is to use a large quantity of yeast and allow it to attack the bread for a short time before baking. In testing the relative values of flours for bread-making purposes, specimen loaves are rolled and baked under constant humidity and temperature and the resulting loaves compared for texture

and elasticity by touch. A loaf should have a moderate tensile strength in order not to crumble easily.

Let us now pass on to some other aspects of food preparation. A large and important branch of confectionery is concerned with the formation of emulsions and jellies. An emulsion differs from the systems we have been considering in that both the continuous and the discrete phases are liquid. A salad dressing is a good example of an emulsion in which an oil is dispersed in an aqueous solution of vinegar as droplets. To get a good emulsion, that is, one in which the one phase is well dispersed as more or less regular and regularly distributed spheres in the other, a number of conditions are necessary. A makeshift emulsion can often be formed merely by shaking the ingredients together, but more complete dispersion is assured if an 'atomiser' is used. This consists of a nozzle having a narrow orifice dipping into what is to be the continuous medium. The second liquid is injected under pressure through the orifice. The size of the droplets which result depends in a rather uncertain manner upon the size of the orifice, the surface tension between the liquids, and the speed of injection, but one can make the fairly general statement that the longer the process is continued—by returning the emulsion to the pressure chamber and respraying through the nozzle—the finer the degree of dispersion becomes.

The breaking-up of the liquid jet into drops can be followed in an instantaneous photograph of any fine jet whether falling into another liquid or into air. It is the result of a tug-of-war between the conservative force of surface tension which would make the jet 'keep itself to itself' and the viscous force which would encourage the jet to spread out and lose its identity in general spray. What usually happens is that a casual disturbance at the jet initiates radial swellings and constrictions. As these pass down the jet they grow in amplitude and eventually nick off the swellings as distinct droplets, which after a certain amount of oscillation settle down to a spherical form and are dispersed as such in the remaining liquid. If the interfacial tension between the phases is large—this

generally implies a large difference in density—and if, in addition, the viscosity is large (so that turbulence is only set up at high velocities), then the jet will be difficult to disperse into drops. On the other hand, if the viscosity of the injected liquid is small as well as the tension between it and the other liquid, dispersion will readily take place. It is therefore easier to make an emulsion of water in oil than of oil in water by atomisation, because the water has a lower viscosity than most oils. Of course, nothing like atomic dimensions of the droplets is ever attained, nor does ease of manufacture imply that the emulsion will remain for long periods.

An alternative and effective method of producing an emulsion of oil in water is to use a supersonic vibrator. A layer of oil is poured over the quartz oscillator to a sufficient depth to cover it and the water above that. On operating the circuit which drives the oscillator, the oil rises in the form of a mound into the water into which it is dispersed as fine drops in a short time.

Whether the emulsion, once formed, remains stable depends on a number of factors. Naturally gravitation is one of the strongest of these. There will be a tendency for the drops to pass to the top or bottom of the vessel and coalesce by collision if the liquid of which they are formed has a specific gravity smaller or greater than that of its surroundings. Mere difference of density will not induce coalescence unless it is assisted by other factors. If, for instance, droplets possess opposite electric charges, the emulsion will soon vanish. It is more probable that they will possess like charges, perhaps acquired by friction in the atomiser, in which case they will not readily unite on collision. If they have adsorbed protective sheaths of electric charge, they are not even likely to come in close contact, but will rebound like a couple of toy balloons.

Surface tension also plays a rôle in preventing the breakdown of an emulsion. It is known that there is a pressure inside a liquid drop greater than that outside by an amount directly proportional to the surface tension between the liquid in the drop and its environment and inversely proportional to the

radius of the drop. Thus when a small drop collides with a big one it tries to relieve this excess pressure by joining up with its fellow and making a single large drop (in the absence of conflicting electrical forces). On the other hand, it resists any tendency to divide into two smaller droplets, as this would increase the total potential energy in the system. Such tendencies are most likely to be introduced by the shearing forces set up when one tries to pull a globule into a lozenge or lens shape. This sort of force can be imitated in the laboratory by floating the drop on its companion liquid in the space between four vertical rollers. The rollers are set in motion so that each one is rotating in the opposite sense to its immediate neighbours. This pulls out the drop sideways until it breaks into two or more fragments. The ease of disruption depends on the size of the drop and the nature of the liquids concerned.

It has long been known that the addition of certain substances to one or other of the two phases promotes the stability of the emulsion and even decides which is going to be the disperse phase. Such substances are called emulsifying agents. The agent is usually a substance soluble in the continuous phase only, or at any rate more soluble in the continuous than in the discrete medium. Soaps are efficient emulsifiers. Thus, if one wants to get benzene emulsified as droplets in water one adds sodium oleate to the latter; on the other hand, the admixture of magnesium oleate with the benzene gives on atomisation an emulsion of water in (continuous) benzene, though this will not persist if the concentration of water is made too high (see Fig. 27). Solids in finely divided form, like natural clay, will also emulsify a two-phase system.

The action of the emulsifying agent is even yet not properly understood, but it is generally agreed amongst physical chemists that it promotes some change in the conditions at the interface, probably a lowering of the surface tension between drops and external liquid. According to the ideas developed by Langmuir, Harkins, and others, the emulsifier is able to bring about a change in the arrangement of the molecules at the interface whereby the adsorbed molecules on

the outside of the drop within the continuous phase fit more snugly to the curvature and so encourage an overall lowering of the surface energy. Certainly when the interfacial tension is low the emulsion is stable and *vice versa*. To adventure further in this line of thought would take us out of physics into surface chemistry.

The next point about an emulsion is its behaviour under

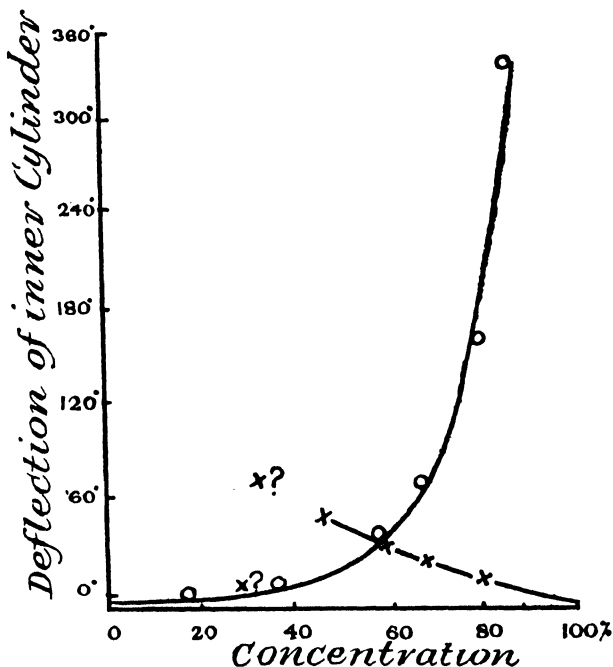

FIG. 27.—VISCOSITY OF EMULSIONS; (CIRCLES) BENZENE IN WATER; (CROSSES) WATER IN BENZENE

stress. This concerns more particularly those emulsions in which the discrete globules are closely packed. The limiting concentration is that determined by the condition that all the drops shall be in contact and so only able to move by rolling over each other like a pile of cannon balls. Naturally, to reach this stage very strong forces resisting coagulation must be in existence, and before it is reached the emulsion is quasi-

solid like butter and the viscosity has reached a very high value. As typical of the change of viscosity with concentration we may take Fig. 27, which shows some results of the author's on emulsions of benzene and water in a concentric cylinder apparatus (*vide* Fig. 19). The benzene is dispersed in water as continuous phase with the addition of a little soft soap to the water to act as stabiliser (these are shown as circles). *Per contra*, the water may be emulsified in the benzene by squirting it through a nozzle, if a little magnesium oleate is put in the latter (these are shown as crosses). The latter does not persist at high concentrations of water. This accounts for the shorter trace of this curve.

At first the viscosity increases directly in proportion to the concentration of the dispersed phase—as theory indicates that it should—but when the concentration of benzene becomes so great that the little spheres interfere with each other's movements and still more when the overcrowding is so serious that they squeeze each other out of spherical shape, the viscosity rises very steeply. The rise in viscosity is such that the logarithm of the viscosity is proportional to the concentration of the disperse phase, another law which can be justified on theoretical grounds. The factor which relates the two is dependent on the 'interphasal compressibility,' or, in plainer language, on the extent to which the discrete medium can crowd out the continuous one. In an emulsion of oil and water considerable overcrowding is possible, but with, say, mercury in water the mercury drops act as rigid spheres, so the viscosity does not rise to such a high value before the increasing concentration of mercury is too much for the inter-liquid barriers and the heavier constituent separates out *en masse* to the bottom of the vessel. A liquid confection may be made to 'stay put' without running away, then, if it can be formed as a fine-grained stable emulsion of high viscosity. This is well seen in the manufacture of cream, which is merely a highly atomised viscous emulsion of milk fat in a small quantity of water. Cream is often now made artificially by injecting butter through a fine vent into milk. Both butter

and milk are themselves emulsions, but the former consists of comparatively coarse drops of fat and very little continuous phase. Salt butter cannot be used for making cream in such an apparatus, partly because it spoils the taste but also because the addition of salt to the water renders the cream emulsion unstable. Of course, all such emulsions have their fluidity much reduced by low temperature. If their continuous phase is frozen out, they become solid, cf. ice cream. A similar effect is produced by scalding cream; this reduces the relative volume of water by evaporation and so immobilises the structure.

Freedom from fluidity, if only temporary, may often be secured by making a froth out of a pure liquid or out of an emulsion. Thus the object of whipping cream is to introduce air bubbles into the mass. If the viscosity was originally fairly high the air bubbles will be held prisoner and be able to rise but slowly into the atmosphere. Further, the film of oil round them will resist puncture. Heather honey—so-called because the bees are taken in their hives to the moors in autumn at the time when the heather is in bloom—has a high viscosity and usually holds air bubbles in it. These do not affect the taste but tickle the æsthetic sense of the purchaser, if not his palate, and as he is willing to pay indirectly for both this and the transport of the bees to the moors, the seller must give the honey a high viscosity by keeping up the sugar content. Perhaps there is some point in the insistence on the permanent occlusion of air bubbles after all, since this indicates that the product has not been watered down!

When the relative volume of air bubbles to liquid becomes very great, a froth results. In certain instances the froth has considerable viscosity and therefore stability, due to the tensile strength of the oil or fatty films enclosing the air like soap bubbles. It is curious that while occluded air bubbles in bars of chocolate were and still are regarded as a defect so that the manufacturer is willing to use sound or even super-sonic vibrations to get rid of them (*vide* previous chapter), he makes up chocolate foams with a large amount of air and is

able to sell them under the name of 'crunches' after the continuous phase has solidified on cooling.

Another instance of a commercial froth not appertaining to confectionery manufacture is to be found in the soapy froths used for foam baths. Sibree has shown that both emulsions and foams show anomalous viscosity of the type we have already discussed in connection with clays. The coefficient of viscosity decreases as the colloidal solution is sheared at faster and faster rates tending towards an ultimate steady value. The viscosity of a froth usually grows progressively less than that of the pure liquid as the gas content is increased.

Temperature also has a potent influence on the fluidity and stability of both emulsions and froths, for warming most liquids reduces both their viscosity and surface tension. Not only, then, is the continuous phase enabled to pass more freely between the obstructing globules, but these in turn find their coagulation encouraged, and the two phases settle out fairly quickly.

In the formation and dissolution of a jelly we perceive a process of great technical importance and that not confined to the kitchen. We shall accordingly consider the process of gelation in some detail. When a substance in solid form such as gelatine leaf is dissolved in water, to all appearance it forms an aqueous solution of moderate fluidity (according to the concentration). The fact that it is a colloidal and not a true solution may be established by passing a beam of light through it and looking at the beam from one side. In a true solution the track of the beam viewed thus askance would be invisible provided no motes were afloat in it, but in the gelatine solution the track is clearly visible, though it has blurred edges, for the colloidal particles scatter the light out of the direct bundle of rays. The beam may even look coloured if the size of the nuclei is of the same order as the wave-length of the light. Such a fluid is called a 'sol' and shows the same anomalies in viscous flow that other colloids do. When gelatine solution is placed in the concentric cylinder viscometer with the hot-wire attachment, the velocity gradients turn out to be of the same

abnormal type which characterised the clay suspensions (cf. Fig. 23, p. 98). As long as it remains in the state of sol it possesses neither rigidity nor elasticity. If a cylinder hung from one end by a wire is held submerged in it, any movement of the upper end of the wire is immediately followed by the cylinder itself until it reaches a new position of equilibrium. Wire and cylinder turn ultimately through equal angles. On the other hand, if the sol turns to a jelly, or 'gel' as it is called in technical practice, a twist of the upper end of the suspension wire is followed up by the cylinder, but *through a smaller angle*, so that the wire remains twisted for some time until the gel slowly relaxes in the same fashion as a lump of dough and the cylinder takes up its initial setting relative to the torsion head, maybe several hours later. Indeed, the gluten in flour gives gel-like properties to the dough made from it.

Much may be learnt about the physical properties accompanying the sol-gel transformation by hanging such a cylinder—or preferably a disc—in the sol formed by dissolving leaf gelatine, such as a cook uses, in warm water and letting it cool. At first, if the disc is given a twist and let go it oscillates to and fro with amplitude diminishing at a rate which depends partly on the constraint which the wire exercises and on the viscosity of the fluid in which it is submerged. The apparatus is used to measure the viscosity of a liquid in terms of the rate of damping of the motion of the disc. The *time* of each swing—which remains constant as long as the properties of the liquid do not change—is a measure of the elasticity of the system: disc plus circumambient fluid. Accordingly, in the present instance, three observations are made simultaneously: (A) the time to execute, say ten swings; (B) the temperature; (C) the time to fall to a given amplitude when the disc is given a rotation of twenty degrees and let go. These observations are repeated every half-hour until the temperature has fallen so far that the sol is set to a firm jelly (Fig. 28). Now the ordinates of (C) on the graph are inversely proportional to the viscosity ( $\mu$ ), or directly proportional to the fluidity, while

those of (A) are inversely as the square root of the elastic factor ( $k$ ). It will be noticed that down to the setting point ( $17^{\circ}$  C.) the fluidity decreases gradually, while the period of swing is practically unchanged (being, in fact, entirely determined by the inertia of the disc ( $m$ ) and the rigidity of the suspending wire), since the sol is devoid of elasticity. When this

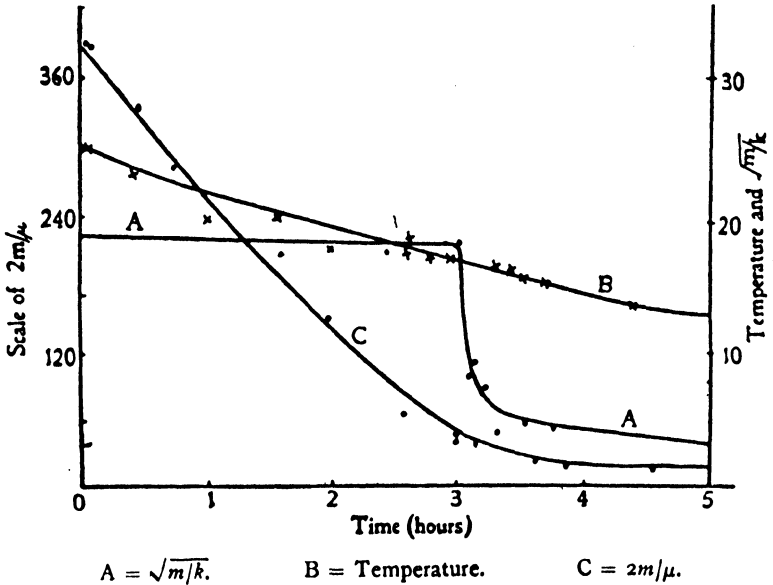

FIG. 28.—DISC OSCILLATING IN GELATINE SOLUTION DURING COOLING; SHOWING (A) TIME-PERIOD OF SWING, (B) TEMPERATURE, (C) FLUIDITY

point is reached (three hours from the making) the solution quite suddenly acquires rigidity, as evidenced by the sudden drop in time of swing of the disc. After that both rigidity and viscosity change slowly, the one increasing while the other decreases with temperature. The elasticity of a successfully made jelly is indicated by its characteristic ‘shimmy’ when newly turned out on to a plate.

This is the usual transmutation of a jelly made in the kitchen, namely, that gelation follows the cooling of the sol. Increase of viscosity is not, however, the paramount factor

which decides when a sol sets to a gel. There are certain sols which can be transformed to a gel by heat. An example is the sol formed by heating nitro-cellulose in benzene. During this time the viscosity is continually decreasing until suddenly at about  $40^{\circ}$  C. the nitro-cellulose suddenly disperses in the benzene to form a gel. The time of swing of the disc suddenly changes but its decrement of amplitude remains unaltered. We conclude, then, that increase of viscosity is not the predominant factor in the setting of a jelly; rather is it the acquirement of elasticity and a definite time of relaxation.

In order to get more detailed information about the behaviour of gelatine to shearing forces during the process of gelation the disc apparatus was modified in the following manner. The suspension wire of the disc was removed and replaced by bearings through which the vertical axle of the disc passed. The upper end of the axle had a horizontal pulley screwed on to it so that by a thread, passing over another pulley on top of the containing vessel, and attached weights the disc could be set spinning in the same way that a child spins a top. This action introduced a shear on the sol surrounding the disc, and cinematograph photos of the subsequent motion of a bright point on the axle enabled one to calculate the velocity and hence the deceleration as the disc was brought to rest by the reaction of the fluid upon it. A control experiment was afterwards performed in the empty vessel to allow for the natural decrement of the disc in its bearings. Results in the form of deceleration : time graphs are shown in Fig. 29 at various epochs during the cooling of the gelatine solution, prepared in warm water. One notices that while the sol remains, the deceleration during the few seconds necessary to bring the disc to rest remains constant, but its value decreases slightly from hour to hour until at ten hours the deceleration varies over quite a range of values in a few seconds. In other words, the gelatine is beginning to get rigid and to make the disc swing a bit before it comes to rest. At ten hours the jelly has definitely set and makes the disc to which it has stuck swing several times to and fro before it stops. This is shown

by the wavy line, from which we can also read off the time of swing, about three-quarters of a second.

Finally an electric motor was coupled to the axle so as to apply a continuous and constant shearing force and, by means of a little hot-wire anemometer attached to the disc, the relative velocity of disc and jelly was measured at several distances from the disc so as to obtain the gradient of velocity going out from the disc. This was also done at several epochs

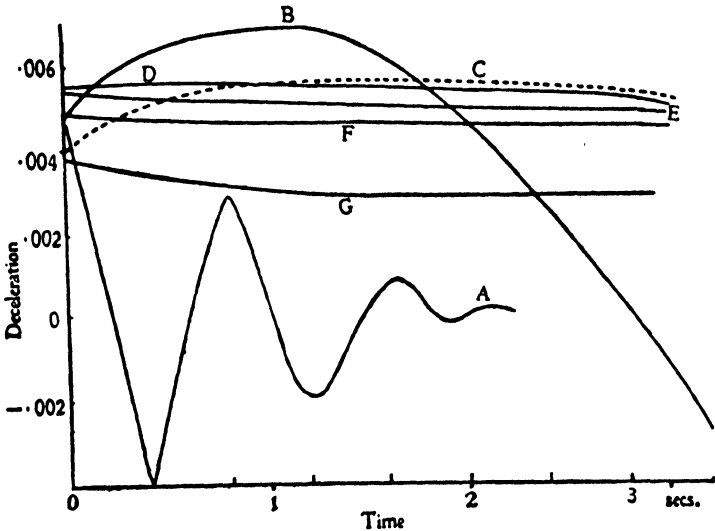

G = Air. F = Start. E = 2 hrs. D = 4 hrs. C = 6 hrs. B = 8 hrs. A = 10 hrs.

FIG. 29.—CHANGE IN DECELERATION OF DISC IN GELATINE SOLUTION DURING COOLING

after the making of the sol as it cooled. At first the sol behaves like any other colloidal suspension. The velocity gradients near the solid boundary are not proportional to the speed of the disc (as they would be in a pure liquid), but are curved in the sense that the faster the disc is rotated the less is the effective viscosity of the 'solution.' Only when the gel sets and moves *en bloc* with the disc is the relative velocity of disc and adhering fluid zero at all speeds. It may be added that the velocity gradients in the last stages were difficult to

measure with the hot-wire. The mass would move as a rigid whole with the disc just before setting, and after a few revolutions a sudden relaxation would occur, often tearing away the hot-wire.

Our conclusion as to the structural changes involved in this process is that a sol resembles a suspension of which the disperse phase is continually increasing in size and occupying a greater proportion of the total volume. When the gel appears, these aggregates link together throughout the structure in such a way that rigidity is acquired.

An old test for the consistency of eggs has recently been put on a quantitative basis for the American poultry trade. If one takes a fresh egg and spins it for a while on a smooth table, touches it momentarily to bring it to rest, and removes the finger, it will start spinning again for a short time of its own accord. A hard-boiled egg will not do this. The reason for this is that the natural egg—like a sol—has fluidity. You do not stop the contents from rotating, merely the shell is held by your finger. On release the liquid begins to drag the shell with it again. The hard egg, on the other hand, has rigidity, like a gel. To compare the consistency of eggs, the egg is made to take the place of the bob of a torsion pendulum (a mass at the end of a suspension wire given a twist and let go). From the rate at which torsional oscillations of the egg die away, as compared with the corresponding factor when the solid bob replaces the egg, the consistency of the contents of the egg may be deduced without breaking the shell. The same thing may be done, but less precisely, by looking at a strong light through the mass of the egg.

Change of temperature is not the only physical factor which can bring about the sol to gel transformation or its reversal. Agitation has a salient influence on the matter. It can delay the formation of a gel in a cooling sol below the proper temperature. It can help to break a jelly up, and in certain instances has such a profound influence on the structure that the sol so formed can never revert to the gel under any circumstances. To illustrate the effect of agitation in inhibiting

gelation the following experiment was carried out. A dipper at the free end of an electro-magnetically maintained vibrating reed—after the fashion of the striker of an electric bell—was kept working at the surface of some warm gelatine solution in such a fashion that ripples were produced on its surface. When the surface was illuminated by the intermittent light of a neon lamp working at the same frequency as the reed the ripples appeared stationary and the distance to which they attained before the crests were so attenuated that they were invisible was noted. This distance is evidently inversely proportional to the viscosity of the fluid, provided the amplitude of the reed's vibration is maintained constant. The distance continually diminished, as was natural, but it was observed that the solution remained liquid at temperatures well below the usual gelation point for this sol when undisturbed ( $18^{\circ}$  C.). In fact the waves did not entirely cease until the temperature was  $10^{\circ}$  C. If the agitation was stopped at any point between these two temperatures, the sol immediately set. Similar results were obtained if the low-frequency vibrator was replaced by a supersonic quartz oscillator working at high frequency under the surface of the fluid. There is no reason to suppose that there is any special effect of this nature due to the high frequency, as we have shown that a frequency of twenty vibrations a second is equally effective as one of twenty thousand in this respect. There is, however, a special effect, which has nothing to do with the physical ones we have been discussing, of supersonics on milk or any similar organic product which is likely to house bacteria. On these, supersonics have a lethal effect, though it is doubtful whether sterilisation by supersonics will ever become a commercial process.

#### SOURCES

- W. Clayton: "Emulsions," 1928.  
F. Halton and G. W. Scott-Blair: "Physical Properties of Flour Doughs" (J. Phys. Chem., **40**, 561, 1936).  
R. Houwink: "Elasticity and Plasticity," 1937.  
D. W. Kent-Jones: "Cereal Chemistry," 1938.

- D. W. Kent-Jones, E. G. Richardson, and R. C. Spalding: "Flour Granularity" (J. Soc. Chem. Ind., **58**, 261, 1939).
- E. G. Richardson: "Viscosity of Emulsions" (Koll. Zeits., **65**, 32, 1933).
- "Mechanics of Gelation" (Trans. Farad. Soc., **19**, 494, 1932).
- N. F. Scarborough: "Sweet Manufacture," 1933.
- G. W. Scott-Blair: "Introduction to Rheology," 1938.
- E. D. Simon: "Physical Science and Flour Milling," 1930.

#### JOURNALS

J. Soc. Chem. Ind. (Food Sec.); Amer. Food J.

## CHAPTER VII

### PHYSICS ON THE FARM

TILTH and conservation of soil fertility are allied to several of the subjects we have had under consideration in the last two chapters. It is essentially a problem in colloid physics, but one more complicated than those which have gone before, principally because one is here dealing with the processes of Nature herself, and these allow of but a moderate interference on the part of man. Much must be taken as one finds it. Even so, there is a lot for the physicist to do, as we shall endeavour to show.

The material in our open-air laboratory consists of a heterogeneous collection of particles, largely silicious or chalky in chemical nature and of all sizes from large rocks down to minute clay granules. The rest of the inorganic matter is composed of metallic salts and oxides and need not greatly concern us while we are thinking of the physical properties of the soil. Along with this inorganic detritus there is a colony of organic matter, large in number if not in size, of which the most important agriculturally are the humus and the bacteria. Last but not least must be included air and water, which penetrate the soil from above and, occasionally, from below.

The soil crumbs have mainly derived from the attrition of rocks, especially the softer ones, some of which may remain *in situ* while the rest is carried by the processes of erosion to cover distant fields. Successive stages in the process of breaking down and washing away can often be traced in the soil profiles exposed by excavation, for example, of road or railway cuttings. In the intimate study of such soil histories mechanical analysis of samples taken at different depths into particle size groups plays a major part. Indeed, apparatus for this purpose was developed primarily to fulfil the needs of the soil surveyor,

who classifies soil types largely through its means. Before making a mechanical analysis of a soil specimen it is dried and weighed. Then it is heated still further to ignite all the combustible matter and reweighed, the difference being equal to the humus content. The carbonates are estimated by extraction with acid, when the soil is ready to be dispersed in the sedi-

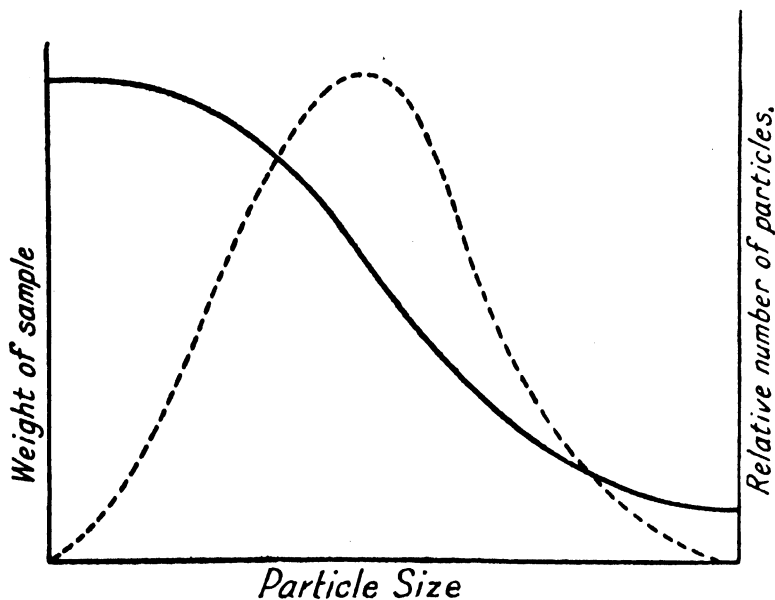

FIG. 30.—MECHANICAL ANALYSIS OF TYPICAL SOIL

Full line: Summation Curve (height proportional to number of particles greater than a given diameter).

Broken line: Distribution Curve (height proportional to number of particles having a given diameter).

mentation tank. (Particles larger than 0.2 mm. (200 microns) are usually taken out by sieving.) As the soil often contains ingredients which promote the formation of aggregates when the soil crumbs come into aqueous suspension, it is usual to disperse these by the addition of a little hydrogen peroxide to the already acid suspension and to stir vigorously before allowing it to settle. The particles are fairly evenly distributed as between the upper limit chosen and sub-microscopic size, as

one would expect in a natural product, but in each specimen the maximum number is found to correspond to a certain size with fairly regular tailing off on either side. When an analysis by sedimentation is made, shallow S-shaped curves such as that shown by the full line in Fig. 30 are obtained with the steepest part of the S occurring at a certain size, which is rather characteristic of the soil type. Thus while a soil of average texture has the regular S for its summation curve with the steepest gradient at  $50\mu$ , a heavy loam will have the maximum shifted to  $100\mu$  and a soil derived from abraded slate such as occurs in Wales will have the up beat of the S removed in the other direction to about  $20\mu$ . When a less precise analysis of particle size is desired, the soil is graded into fractions corresponding to the following limits: 2 mm. to 0.2 mm. ('coarse sand'), 200 to 20 microns ('fine sand'), 20 to 2 microns ('silt'), less than 2 microns ('clay').

All that we have said in Chapter V with regard to the fluidity and cohesion of clays applies with equal force when the clay is on its native heath. Ploughing is one of the major operations performed on the soil either with the object of turning it over to allow the air free access for the subsequent breaking up into smaller crumbs when the frosts come, or to plough in stubble or weeds to increase the organic content, or again to make furrows for planting seeds. Work is done by the plough partly against gravity since the clods have to be lifted out of the earth even if the plough is not actually going uphill. Much research has been done on the best shape to be given to the mouldboard of the plough for accomplishing this object with the minimum expenditure of energy on the part of horse or motor. The plough also has to cleave the soil before it lifts it out of the furrow, and this work is done to overcome viscous forces. Except that it is not the same soil which is sheared all the time, the reaction of the soil to the plough is very similar to that of the clay paste to the walls of a viscometer, particularly perhaps to one of the concentric cylinder type as pictured in Fig. 19, p. 92. The cohesion of the soil may vary a great deal over a small distance due to differences in texture

and in water content. With this and the notoriously fickle British climate, a considerable variation in plough draft can be found in a single field at different locations and seasons. Anyone who has occasion to walk over a ploughed field in all kinds of weather will be well aware of this. In spite of this inconstancy it is worth the agricultural engineer's time to compile data on the work done by the plough in traversing a field. The instrument which does this is the dynamometer, which we have already described in use on railway tracks, and in principle is an extensible spring in the drawbar between coulter and horses (or tractor). As the plough cuts a furrow, a continuous record of the effort exerted by the propelling agent is given by the extension of the spring, which will be greater at the difficult portions of the terrain. As far as possible the plough should be pulled at constant speed across the field, so that this sort of experiment is best carried out with a powerful tractor rather than with horse propulsion. This is repeated on a number of parallel furrows until the whole field has been ploughed. Although, as we have noted, the tractive effort is by no means constant along a furrow, the ups and downs of the record being far more frequent than on train dynamometer records, when the whole series of traces is analysed it can be seen that these indentations are not fortuitous but have a significance for the whole plot; in the same way that measurements of the height above sea-level would when made over a tilted field. One can in fact sketch over a map of the plot contours of equal drawbar pull, which can be correlated with measurements of grain size and moisture distribution taken at corresponding points in the surface soil.

The other operations apart from ploughing on an arable farm are those concerned with further reducing the size of the soil crumbs after weathering and in making the crumb size uniform and in securing adequate pore space after rain or the treading of men and animals have consolidated the soil once more. The forces acting on a soil particle while it is passing over the mouldboard of the plough have been classified as follows : (1) a force acting outwards from the board in a direc-

tion perpendicular to its surface at every point, (2) gravity, (3) the weight of the soil above the particle, (4) friction between the particle and the surface of the board, (5) actions due to the relative motion of the particle and its neighbours resulting in shearing forces, compressions, and tensions. It may be remarked that none of these forces except gravity remains constant during the process. They vary from time to time and from point to point in a given furrow. In particular the varying water and clay contents of the soil in different parts of the same field may change one of these—the friction between the board and the surface layer of the furrow—by as much as one hundred per cent. It is therefore not to be wondered at that the effort exerted by the horse or tractor may change considerably in different parts of the same field and that dynamometer records on ploughed fields are by no means as steady as those gained on the railways.

The shape of the mouldboard can be developed from first principles, having regard to the work which it has to do. A slice of the furrow is first cut by the coulter and ploughshare and is turned about one corner until it reaches a vertical position. It is then carried beyond this position through a further angle and laid to rest against the preceding slice that was turned. The forepart of the mouldboard is therefore given a helical form to carry out the turning motion, but thereafter this twist is combined with a lateral displacement of the upper portion of the slice while the corner about which the turning has taken place remains at the bottom of the furrow.

In addition the tail is prolonged or spread out to press the slice into position against its predecessor. In Great Britain a gently curving convex mouldboard is preferred to the sharply curved concave form which, under the name of 'digger,' is common in the United States, because it gives neater and smoother furrows. Both on the European and American continents, sowing usually follows hard on the heels of ploughing, so that it is necessary to have more breaking up of the furrow clods than in this country where the latter work is left to the weather to do during the winter. When ploughing

is to be done on a larger scale so as to cut several furrows at a time, rotary discs are employed, mounted on a horizontal axis set at an angle somewhat less than 90 degrees to the direction in which the machine is pulled so that the discs tear up furrows as they cleave their way through the soil.

If the speed of ploughing is increased, the work done in cutting a furrow is not the same; it, in fact, increases, as we should expect from our knowledge of the plasticity of clay and other pastes in the laboratory. We observed that the apparent viscosity of a clay and water mixture in the concentric cylinder viscometer diminished as the speed of the outer one increased. In other words, the work done in shearing a given quantity of soil can bear a smaller ratio to the work done by the tractor if it is done faster.

Dynamometer measurements of the resistance offered by the soil to the ploughshare show a similar variation with regard to speed as the torque: speed curves of Fig. 20, p. 94, at least in the final stage. For instance, experiments have shown that a doubling of the speed of the plough from two to four miles per hour increases the resisting force in the ratio 10 : 11 only, so that for an equal length of furrow the work done by the tractor is increased in the same ratio. The extra fuel cost may be more than compensated by the saving in operating time and in soils which can only be ploughed in a very limited range of optimum soil conditions, the success or failure of the crop may depend on the extent to which the occurrence of these conditions has been utilised.

Research is yet wanting on the effect of particle size on viscosity, and hence on the resistance of the soil to cleavage, but it is known that, speaking generally, the existence of fine particles below two microns in diameter among the soil crumbs acts as an effective lubricant to the mass. Indeed, some chemists hold that such a soil becomes in effect a thixotropic gel. In repose, the soil is consolidated, or glued together, as it were by this filling of fine colloidal material, but the imposition of pressure or shear on it breaks down the gel and gives freedom to the passage of the plough. In this way a heavy-looking soil

may in practice prove easier to plough up than its appearance would lead one to expect. In this way, too, an apparently firm sandy foreshore may prove treacherous to walk on. It has indeed been demonstrated in the laboratory that if the fine clay particles are removed from a sample of quicksand it is capable of supporting loads which formerly sank incontinently through it.

Although the intimate admixture of fine silt to stubborn soils is not practicable on a large scale, other attempts have been made to increase the fluidity of the soil in the immediate vicinity of the cutting edge and so to reduce the work of ploughing. Some research was carried out at Rothamsted Experimental Station some years ago to see whether electrification of the soil would be a worth-while proposition in terms of ploughing costs.

When insoluble colloid particles are in suspension they are usually found to be negatively charged with respect to the water molecules. If then a negatively charged plough were driven through the soil, it ought to pick up a film of positive water molecules while the solid soil granules would be driven away. The film would lubricate the cutting edge like the film of water under an ice skate, and reduce the resistance to its passage. Laboratory tests were made with a model plough in which the mouldboard was connected to the negative pole of a battery while the coulter—the knife which runs in front to divide the earth—was made positive. Considerable reduction in drawbar pull was found when the electrical connections were made, but when an actual plough was used in the field a disappointingly small improvement of a few per cent. was registered.

We come next to the important matter of the percolation of water through the soil and its retention therein. There are a number of ways of regarding these soil-water relationships, based on analogues derived from problems better known in the physical laboratory, where the soil is an infrequent intruder. If we are thinking more of the static conditions in the ground, it is useful to think of the problem as one in surface tension; but

when conditions are changing, an analogy with the flow of heat or of electricity in a conductor is more illuminating. The true conditions are anything but simple, and both likenesses must be treated with a certain amount of reserve. The vapour pressure of the moisture in the atmosphere and the evaporation which is activated by it must also be taken into account.

To the former mode of attack, the soil consists of a solid mass, honeycombed with a myriad interconnected pores, which taken together are assimilated to a large number of vertical capillary tubes whose average size depends on the mean size of the particles themselves and the closeness of their packing. (This is because the mathematical physicist is used to dealing with the 'capillary attraction' of water in tubes, but finds himself at a loss when other configurations are presented to him.) If the grains are packed together as tightly as possible, the size of these pores will obviously be proportional to the size of the grains themselves. Let us now suppose that rain has fallen and has seeped through the soil down to the impervious rock on which the water would, in the absence of surface tension, lie in a pool. Just as in dipping a fine tube in a liquid, the soil water now rises by capillary attraction to a certain height in the pore space which is inversely proportional to the mean pore width, or diameter of the imaginary nest of uniform capillary tubes which is to replace them. If the distance from the water table to the top surface of the soil is less than this capillary rise proper to the mean pore width, the soil will remain waterlogged until evaporation at the surface has reduced the volume of water on the rock table below that necessary to saturate the wholestratum. While this equilibrium condition is being attained there is accordingly a continual transfer of water from the rock beneath to the atmosphere above.

This suffices to give a crude picture of the conditions in the ground while there is no considerable affluence or rapid removal of water. At any rate, it explains why a clayey soil is more often waterlogged than a sandy one, but it fails to explain what happens during and just after a heavy shower. It must also be remembered that the conception of a 'mean capillary

diameter' for the soil above the water table is merely a convenient figment.

The second analogue is more convincing since it covers all states, whether equilibrium has been reached or not. It is again a ramification of capillaries that one thinks of, but viscosity as well as surface tension is recognised as a controlling factor. The former comes into the process wherever there is a difference of pressure promoting the flow of water. Part of this pressure gradient arises from the natural tendency of water to find a lower level and the rest from the suction of the water into the interstices of the soil structure, and may act in any direction. When rain falls on the surface of the ground it is urged downward under the action of gravity, but surface tension sets a restraint on this motion since it urges the soil to retain some of this water in spite of the force of gravity. The extent to which the soil can resist the percolation of water to lower levels depends on the texture of the soil and on the depth that the water table lies below; the distance from the point where the water is passing at any moment to the level of stagnant water is, in fact, a measure of the downward hydrostatic tension exerted by gravity on the water in the soil. The extent of retention of the new-fallen rain-water by the soil also depends on how nearly the soil is already saturated by earlier rain and on the amount of evaporation into the atmosphere, but for the present we shall suppose that the atmosphere is saturated as it would be just after a heavy fall of rain, so that there is no loss by evaporation.

To measure the amount of water retained by the soil, an apparatus due to Rogers may be used. It consists of a porous pot containing some water, and to the upper end of the pot is attached a tube leading to a manometer. The pot is buried in the soil to the depth of a few feet, and the tube led up above ground to the manometer which measures the pressure inside the pot. (Initially, this may be set at any suitable value by squeezing in or removing air from the system when the bulb is connected to the main tube.) As the moisture content outside the pot changes, water is drawn out or driven in by capillary

tension, and the reading of the manometer changes. As long as the instrument is kept at the same place, the readings will depend solely on the moisture content, and the apparatus can be calibrated by taking samples of the soil corresponding to different readings of the pressure gauge and determining the water content of the specimens by weighing them wet and dried. In other types of soil a new calibration will be necessary as the pressures depend on the pore space.

To illustrate the behaviour of the soil when subjected to forces tending to dry it, the apparatus shown in Fig. 31 due to Haines may be used. It consists of a porcelain trough, pierced at the bottom with a series of small holes, in which the specimen is placed as far as possible without disturbing its natural texture. The sample is taken by pushing a sharp-edged tin of the same diameter as the trough, but with a hole at the top to admit air, into the ground, cleaning off the soil from outside and cutting the superfluity off level with the base. So one removes a divot of soil in its natural state. Below the trough, an air-tight tube leads down and is bent round upon itself to form a U-tube. The soil in the desiccated state is now given a known amount of water and the U-tube filled with mercury until it just reaches to the bottom of the trough and stands at A in the opposite limb. An airtight top is now fitted on the trough and a tension put upon the soil by lowering the level of the mercury in the stand pipe to B, the tap below being opened for this purpose. A head of mercury equal to the height AB now acts to draw water out of the soil, and the water moves at a rate dependent on this pressure and the resistance offered by the soil, which is a function of the pore space. Eventually, if the head AB is kept constant, an equilibrium will be reached at which the moisture content of the soil remains fixed, but naturally less than that at the start. The resulting moisture content can be found by removing and reweighing the specimen. In this way, increasing the height AB by steps, a series of equilibrium moisture contents, corresponding to a series of drying-out tensions, may be obtained. It will be found, however, that

there is a limiting water content below which one cannot remove further moisture, no matter how great the tension. (Incidentally, this sets a lower limit to the range of moisture meters which work on this principle.) This water which the soil holds so tenaciously is of great importance for the life of plants. An interesting observation is this, that if one reduces the tension  $AB$  step-by-step to zero, taking equilibrium readings of water content meanwhile, the course followed by the results is not exactly the same as that followed by the first set. The curve for re-wetting lies below that for drying-out. The results are shown on Fig. 32, in which for convenience the drying or wetting potential (tension head,  $AB$ ) is expressed in logarithmic units, as so many centimetres of water, and labelled  $\rho F$ , imitating the device for recording electrical potentials in solutions in terms of acid strengths ( $\rho H$ ). Thus atmospheric pressure corresponds to a column of water 1,000 cm. high, and its logarithm is 3; consequently  $\rho F = 3$  on this scale marks the normal atmospheric pressure. The water concentration for equilibrium is then about one-quarter of the soil weight for this particular soil. Oven dryness corresponds to a  $\rho F$  of 7—the pull of a water column higher than Mount Everest would be required to produce this degree of desiccation. At the other extreme when the pore spaces are completely soaked they hold about 45 per cent. of their total weight in water, and

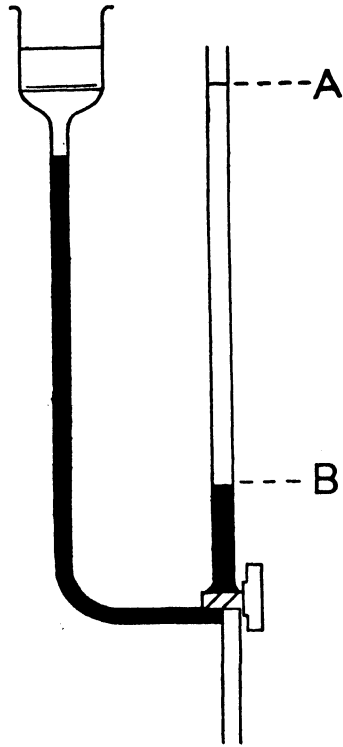

FIG. 31.—MOISTURE METER FOR SOIL (*Haines*)

this occurs at a  $pF$  of zero. The high points on the curves, in equilibrium with very tall pressure columns, must be determined by indirect means as weighing is not accurate enough, and as well the parts of the curve beyond 40 per cent. moisture must be regarded as ideal. One of these involves measuring the heat of re-wetting of the specimen. When water is added to a fairly dry specimen there is a certain amount of chemical action and heat is evolved to an extent which is a known function of the pre-existing humidity. This heat is determined for the specimen, after it has come to equilibrium with the necessary tall column of mercury, by the usual method adopted in the physical laboratory for heats of fusion or solution. The water is added to the soil in a calorimeter, and the heat evolved determined from the rise of temperature produced in the calorimeter and its contents. Thus, the heat of wetting for one gram is known and hence the original moisture content.

Another technique for these low moisture contents depends on the fact that when water is adulterated with other substances the freezing-point of the mixture is lower than that of pure water by an amount dependent on the relative concentration. In the same way, if the temperature of the soil sample is gradually lowered, the water in the interstices will freeze at a temperature lower than the normal freezing-point of water by a fraction of a degree and the remelting on warming occurs at the same lowered temperature. The amount of this lowering of freezing-point, read on a sensitive thermometer, can be correlated with the amount of water in the soil.

A third but indirect method for obtaining a reading corresponding to the lower humidities, not requiring the use of physical apparatus other than a balance, is based on a fact that we have already hinted at, namely, that a certain proportion of the moisture is held so tenaciously that it cannot be removed by moderate suction. It is therefore held by most botanists that this water is not available for the use of plants. One must remember that the plant exerting osmotic pressure through the cellular membrane of its roots is able to do

naturally what we can do with the suction apparatus artificially, that is, to draw water out of the soil. When the soil is so dry that the maximum osmotic pressure that the plant can exert

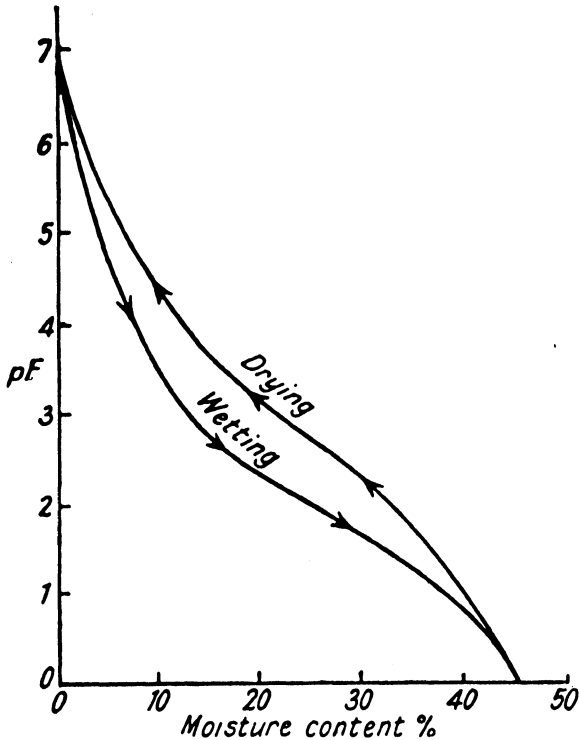

—Height of Water Column (plotted logarithmically as  $pF$ ) in equilibrium with soil at various moisture contents (after Schofield).

FIG. 32.—MOISTURE: VAPOUR PRESSURE CURVES FOR DRYING AND WETTING OF SOIL

does not suffice to draw any more water, it wilts and at length dies. The remaining water can then be estimated by ignition and weighing a specimen and gives a point on the curve, if the maximum osmotic pressure which the plant exerts is known.

As long as water can move quickly from the water table

to the surface evaporation will proceed steadily, but if, as in summer, the evaporation rate is high, the water movement from below cannot make good the loss and the soil surface becomes drier and the rate of evaporation decreases rapidly from its initial high value. Similarly, plants dry out the soil during growth and in drought movement of water will depend on the hydrostatic head above the water table and the texture of the soil. The texture determines the limiting value of the hydrostatic head and the rate at which it is reached. Thus a sandy soil drains more rapidly than a clay soil, a condition generally favourable to plant growth. In wet weather the sand drains more rapidly, in dry weather the clay retains more water in the root zone. The happy medium—a loam—possesses both advantages.

The shape of the hysteresis loop of Fig. 32 is typical of the soil nature. For instance, if it has a very uniform pore size, the initial suction necessary to fill or empty the pores will cause a large amount of water to enter or leave the soil so that the curves will be nearly parallel to the moisture axis, the value of the critical suction increasing as the pore size decreases. Thus for a coarse sand, the majority of the pores fill when  $pF$  equals 2, but for a uniform clay fraction when  $pF$  equals 5. As the range of pore size increases these flat portions of the curves become less obvious, and the S loop reverts to a straight diagonal line. The shape of the curve does, in fact, closely follow the shape of the summation curve in the mechanical analysis of the same soil.

The pore space, by the way, is readily estimated if a known volume of dry soil is taken in a measuring vessel and soaked with water to repletion. In the absence of swelling, the volume of water added represents the total pore space in the original volume of solid.

Reverting to the looped curves; these are of the greatest importance for an assessment of the behaviour of the soil in relation to plant growth. The slow response of the moisture content to change of hydrostatic pressure is of advantage to the plant in this way that when, in a drought,

the water table is falling, the humidity does not at once fall but takes time to reach the new equilibrium moisture content. Even when the water table falls slowly, increasing the suction tension, enough water remains to keep the plant alive for a considerable time; whereas when the drought breaks, the first excess falls freely to the water table—'to fill up the tanks,' so to speak—while that held in the soil rises in volume more slowly. In this 'refuelling' process much depends on the nature of the topsoil. Through a sandy or light loam the water percolates freely. It turns off the surface of a sunbaked clay to run to the brooks, without penetration except in so far as there are cracks to enter.

Coming now to the upper end of the 'soil laboratory' we must examine the relationship between the soil and its atmosphere. Pore space will again be the criterion to establish the aeration of the soil. Similar considerations may be applied to gaseous penetration to those which we brought to bear on the water relationships, save that surface tension cannot enter here; it is purely the problem of the flow of a fluid of small viscosity into a multi-cellular mass. Neither does gravity have such a big say. Diffusion is more potent than gravity in directing air movements. The micro-organisms in the soil and the roots of plants continually produce carbon dioxide, which diffuses more slowly into the atmosphere than the air enters in, on account of its superior density, so that in the absence of free circulation, the composition of this bound atmosphere tends to be different from the free one in the air above. Nitrogen is removed from the soil crumb gaseous atmosphere and 'fixed' in the form of soluble salts by other bacteria.

The amount of water vapour in the soil atmosphere naturally changes with the wetness of the soil itself. The water vapour pressure in samples of the air aspirated therefrom is indicative of the amount of the condensed water therein; but the pressure also depends on the general humidity prevailing in the air above. If the free atmosphere is dry while that below ground is moist, water vapour will pass up and out, and this causes

evaporation of the soil moisture so that a process of distillation is set up. The reverse process takes place where we find a saturated atmosphere over a dry soil bed.

All these air and water movements are accompanied by changes of temperature. Evaporation cannot take place without a supply of latent heat, and this will usually come from the ground itself, so lowering the soil temperature. Conversely, condensation will tend to warm the soil. These two tendencies on the whole keep the soil from suffering undue changes of temperature, for evaporation will take place, other things being equal, when the surface is being warmed by the rising sun and condensation will ensue in the cool of the evening. Another factor which limits such changes as do occur to the top few inches of the ground is the poor conductivity of the dry earth. The conductivity rises, however, very rapidly with moisture content, being nearly doubled for a moisture rise from 0 to 15 per cent., afterwards rising more slowly and eventually approximating to the value proper to pure water. Even so, this is small compared to that of most solid bodies, provided the air is inhibited from convection, as it is by the granular obstacles. At many agricultural experiment stations, records of the temperature at various depths down to several feet are maintained, so as to correlate temperature with plant growth. Naturally, ordinary mercury in glass thermometers are useless for this work. Thermo-couples are sunk into the ground through insulating cables to the requisite depth and connected to galvanometers above ground to give continuous records of the temperature by day and night. On a record taken near the surface the diurnal variation of hot and cold is apparent though its amplitude is not so great as in the air above. Lower down the maximum day temperatures depart less and less from the mean and, moreover, occur progressively later than the early afternoon which is the hottest time in the atmosphere. This lag and diminution in the amplitude is a feature of attenuated wave motion. Such we have here, but the waves passing into the ground are waves of heat and not the more common sound waves. Deep down the daily inter-

change of hot and cold has vanished, but there is still a very gradual trend up—in spring—or down—in autumn—corresponding to the slow annual alternation of seasons. The degradation of amplitude and lag in temperature maximum are related to the thermal properties of the soil. It results that the roots of a large plant are but little affected by casual changes in the air temperature unless these are very severe and protracted. This is of the greatest importance for the maintenance of plant life, since it means that hard frosts cannot do the damage to a plant through its roots which they could do if the earth were a good conductor of heat.

All that we have said with regard to the relation between the soil and its air and moisture respectively is most significant to what the farmer and the gardener call 'tilth.' This is a manipulation of the soil to secure that roots are kept aerated and watered. Of course, in a very fertile soil under good climatic conditions such manual interference may not be required, but in proportion as the soil is sterile and the climate arid, so work of this kind becomes a necessity. As we have seen, the rainfall, unless it runs straight off, will finally descend to the local water table, and in attaining equilibrium conditions it will reach the roots by capillary attraction. Evidently then, compactness below the roots is needed to promote a large capillary tension and to draw water up from the impervious stratum or rock below. The surface soil down to root level, on the other hand, should be broken up into larger crumbs in order to let in the rain, and—once entered—to prevent it climbing back by capillary attraction to the surface, where it would suffer loss by evaporation. Physically, the ground will then resemble a nest of vertical capillary tubes widening out at the top. Too compact a surface brings another fault: excessive run-off during rainfall and evaporation subsequently. Breaking it up will assist the aeration of the roots.

The principal functions of soil tillage are therefore (1) by deep ploughing or digging to bring new divots—with their colonies of bacteria unexhausted by crop cultivation—to the

top; these are subsequently broken up and recompactd in smaller units by frost and trampling of cattle, (2) by light digging or harrowing to aerate the ground for the reception of seed, and (3) by hoeing to maintain the crumbly nature of the soil above root level, since heavy rain may increase the granularity to a finer dispersion than is desirable.

In northern climes, it is desirable that for certain crops the soil temperature should be raised above that ordained by nature. Formerly—and still to a certain extent—hot-beds were constructed of natural manure, which by its decomposition supplied the heat of the reaction that it underwent to the plants. As the fermentation proceeds the temperature falls, and unless the supply of manure is replenished the hot-bed becomes cold in a few weeks. In an effort to maintain the temperature at the will of the grower, steam pipes have been used, but the installation requires constant attention at the boiler fires. In Oslo about ten years ago electrical heating of the soil was tried and met with instant success. Insulated resistance wire in a lead casing was used. Electrical heating is now becoming *de rigueur* for hot-beds; also in greenhouses near the plant roots. The frame containing the soil is best insulated against heat losses below and at the sides with a layer of coke, an inexpensive insulator. A layer of sand is set above the bottom layer of coke and in this the cables are laid, or they may be passed through earthenware pipes which permit the tracing and repair of a fault without dismantling the whole bed. With a moderate output of electrical power the temperature rises rapidly and may then be maintained at about 60° F. with very little further expenditure of energy. The rate at which the soil warms up depends on its thermal properties and the conservation of the heat depends on how well the frame has been insulated. If the earth is wet, the rise is less rapid, while sandy loam having about twice the conductivity of heavy clay also takes a long time to warm up.

To the market gardener it is the cost and results that matter. For tomatoes in England it is well worth while from both aspects, provided the price of electricity per unit is not too

high. (In many districts the farmer can obtain an economical rate by using the current only at night, leaving the sun to maintain the temperature during the day.) To save keeping a constant watch on the apparatus, the temperature may be left under the automatic control of a thermostat.

While we are dealing with modern uses of electricity on the farm we might mention that wire fences, whose metallic portions are given a slight electric potential over the earth, are in use to prevent cattle leaning on or rubbing their bodies against them. The interesting thing about these electric fences is that once the cattle have received a slight shock by contact they will avoid the fence, so that it is no longer necessary to connect the battery until a new herd uses the field! But this is leading us out of physics into psychology.

Another process on the farm which involves thermal physics is ensilage, the preservation of the summer harvest—usually of root crops—against winter deterioration and action of mould by storing in an air-tight enclosure maintained at an even temperature despite frost. This actually is a very ancient practice. During the past century pounds were built by stacking swedes, etc., and covering all round with straw and earth to insulate the contents of the pounds until they were required for winter cattle food. Nowadays such a store is made more efficient by building tall concrete towers to act as silos. Instead of stacking hay into ricks after it has been cut and dried in the fields, it is now thought worth while to dry the swathes in a sort of wind tunnel through which hot air from a heating plant passes. Drying then takes place in a very short time and the artificially cooked hay may be carried straight to the silo almost as fast as it is cut, thus eliminating the vexatious delay between the two operations, during which the farmer may see his hay spoilt by rain in the field, or—if he be too hasty—see his ricks given up to internal combustion.

#### SOURCES

N. M. Comber: "Introduction to Science of Soil," 1937.

W. B. Haines: "Hysteresis in Capillary Properties of Soil" (J. Agric. Sci., **20**, 97, 1930).

## 144 PHYSICAL SCIENCE IN ART AND INDUSTRY

B. A. Keen: "Physical Properties of Soil," 1931.

E. G. Richardson: "Cohesion and Viscosity of Clays" (J. Agric. Sci., **23**, 176, 1933).

— "Optical Method for Mechanical Analysis" (J. Agric. Sci., **24**, 457, 1934).

— "Physical Properties of Disperse Systems" (Science Progress, **31**, 426, 1936).

G. W. Robinson: "Soils," 1932.

R. K. Schofield: "The  $\rho F$  of Water in Soil" (Trans. 3rd Congress Soil Sci., **1**, 90, 1935).

### JOURNALS

J. Agric. Science; Soil Science (Amer.); Tropical Agriculture: Rep. Inter. Congresses of Soil Science.

## RIVER HYDROLOGY

PROBLEMS rather similar to those which we have discussed in the preceding chapter are raised by studies of the large movements of water whether in natural or artificial channels or in the sea. The science of hydrology is not of recent origin. The Ancient Romans with their marvellous system of water-supply had a good empirical knowledge of the laws governing the size and slope of an aqueduct in relation to the 'head' of water and its rate of flow. One of the most fundamental of these, and the earliest to be given theoretical confirmation, is that which determines, in the absence of frictional losses, the outflow from an orifice at a given depth below the free surface of a reservoir. The Romans thought that the velocity of outflow was directly proportional to this depth, but Torricelli—an Italian engineer of the seventeenth century—showed by considering the energy changes involved that the velocity was more truly proportional to the square root of the depth. Of course, it was recognised that friction, either at the sides of the hole or along the walls of the exit conduit if the reservoir fed an aqueduct, reduced the practical outflow below the value indicated by Torricelli's law, but it remained a useful guide to water engineers for many years after. The first engineer to give useful consideration to the effects of friction was D'Arcy, who pointed out that if the flow in a river remains constant from place to place, as it must do if it is neither heaped up in its channel nor allowed to spread over the surrounding valley, the potential energy which it loses on its downward course must be exactly equal to that dissipated in friction, either in the water itself, if it becomes turbulent, or against the banks and bed where the gradient of velocity sets up a shearing force. If, then, a river is to be carried without flooding down

a channel of a certain slope, it must travel at such a mean speed that the loss of potential energy balances the viscous dissipation. This problem is one of the most serious that confronts the river engineer; to get sufficient energy dissipation to enable the river to get down to the sea-level within the permitted slope. If this is insufficient, the river will be liable to flood whenever its head waters rise; if it is too great, the bed and banks will be eroded extensively and—if the river is open to traffic—navigation will be impeded.

The same problem confronts the builders of hydro-electric stations. On many such systems the outlet for the water after it has passed through the turbines is by a natural river in which fishing is preserved. In Scotland, for example, the construction of such stations, collecting as they do quantities of water from a considerable watershed to pour down an erstwhile sluggish stream, has so increased the speed and volume of the water passing down as to interfere seriously with the normal life of the salmon which require to penetrate to the upper reaches periodically for spawning. The difficulty may be overcome by giving the fish a ladder consisting of a series of shallow waterfalls at the steep pitches. This, however, is tiring for the fish and may shut off a number of the weaker ones from their natural breeding grounds. A better device ensures the necessary energy dissipation in the water while leaving 'passes' for the fish in which the current is weaker and against which the fish may prevail. One type of fish pass in a steep channel involves a series of plates leaning upstream and out of which rectangular notches have been cut. The object is to slow down the water in the neighbourhood of the walls and floor of the channel, up which the fish can creep, while preserving a good fast flow in the main unobstructed part of the stream. The weirs themselves dissipate energy by setting up circulating eddies between the obstacles and diminish erosion on the channel walls. It is necessary that they shall be close together, otherwise waterfalls will form over each instead of the water shooting straight down the centre of the channel in the desired way. A similar construction may be

used for water runways to float timber down to railhead or port.

Yet another type of fish pass consists of a number of pools connected by drowned orifices which, instead of leading directly from one pool to the next are staggered in respect to the general direction of flow, so that as the submerged jet embouches from one pool to the next it sets up a circulation in the pool as well as intense energy dissipation along the surface

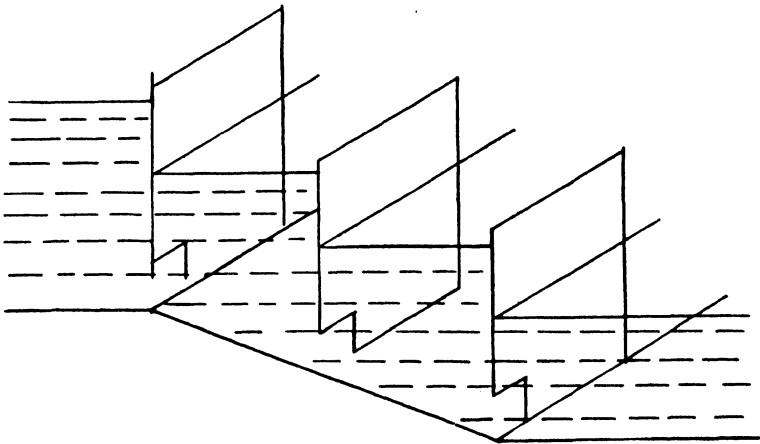

FIG. 33.—SUBMERGED ORIFICE FISH PASS (IN SECTION)

of discontinuity formed between the diverted jet and the dead water on either side. This reduces the general current in spite of the steep grade—reckoned from pool to pool—and lets the water down gently, while fish are able to make their way from pool to pool against the current through the orifice. A schematic diagram of such a fish pass is shown in Fig. 33. This type of pass is expensive to construct and is only adopted where a very steep fall in the river channel has to be surmounted, as, for instance, in the spillway of a hydro-electric station from the dam at the end of the reservoir. The fish pass will then form a by-pass to the main stream and at its outlet to the stream will have guide vanes to direct the fish into and up it. Further, since the volume of the main stream may vary quite a deal with the seasons, some control—

manually operated or automatic—must be exercised to divert sufficient water into the pass to keep the orifices ‘drowned’ under all conditions.

Other problems of a physical nature which confront the river engineer concern the tendency of a river to meander and the cutting off of such divagations by means of canals. A meander starts where a river travelling through an alluvial plain is diverted a little from its straight way, possibly by encountering a harder resisting rock, so that it makes a curve to pass the obstruction. At every such divarication the current round the outside of the bend tends to move faster and erode the bank, while on the inside any silt carried tends to settle at the lower average speed. The result of this process is a gradual increase in the length and curvature of each bend with a curve in the opposite sense following the first formed and so on until the river leaves the plain and perhaps finds an outlet through a gorge to another plain or into the sea. This sinuous course, besides being a nuisance to navigation, holds up the water in flood so that attempts will be made to shorten the course by a deep cut, confining the water in a track determined by man (in the shape of the River Commission). Before embarking on an improvement of this nature, which may involve the release of immense forces and change the whole feature of the navigation and irrigation lower down, the engineers will construct a model of the affected portion and, by studying the behaviour of water in the model, try to predict the full-scale effects which the project will initiate.

Even if possibilities of silting and erosion are entirely left out of account, the engineer will perforce have to ignore in the construction and operation of such a model some of the niceties of scale effect which the ‘aeronautical and naval engineers, faced with a smaller number of variable factors, can include in their model work. Omitting factors involving time, it is still impossible to simulate the true geometric scale of the project. Thus, suppose that the project covers ten miles of the actual river and in the laboratory is to be represented by a channel ten feet long. The width of the real river may be two hundred

feet, the depth twenty-five, and the mean current five miles per hour. Simple calculation will show that on a true scale the model canal must be about two-thirds of an inch wide and one-ninth of an inch deep, while to get equality of Reynolds' Numbers in the two régimes the water in the model must travel at nearly nine thousand miles an hour! In actual model work the lateral section of the channel is misrepresented. Its width is made considerably greater than the longitudinal dimension would warrant and the depth may be still more exaggerated. A convenient cross-section for the model in the case we have cited would be nine inches wide by six inches deep, while the head of water initiating flow from one end to the other would be possibly one-eighth of the expected full-scale value. Even so, the model Reynolds' Number falls far below the real one, but since the flow is usually completely turbulent in both cases and the engineer will be satisfied with rough agreement in the behaviour of the two systems, the disparity in Reynolds' Number is not viewed with such gravity as a comparable amount in aeronautical testing would be by an aircraft designer.

If the river or canal which is being studied in the hydraulic laboratory is subject to tidal influence, then a suitable alternation of head at the two ends of the model, operating in simple harmonic fashion, must be ensured. This period, too, must be scaled down so that tides occur in the model at a higher frequency than one or two per diem. Thus in a model constructed to study the effect of enlarging the Cape Cod canal in Massachusetts to enable liners to save a considerable distance in travelling between New York and Boston, the tidal period is completed in twenty-four minutes instead of as many hours, water being carried through a pipe under the model from the 'Buszard's Bay' outflow tank to the 'Cape Cod' inflow tank, with the precision of the lunar variations of head at the two ends of the real canal. Among characteristics of the widened canal which such a model can predict in advance of the engineering works are existence of circulating currents at the embouchures of the canal, differences of level at various states of

tide between places within the canal and its affluents, and amplitude of the tidal fluctuation at any point, due regard being had to scale effects. Bridge piers and abutments must naturally be included at the proper locations and scale, since these affect the flow. The actual forces upon them are best found by separate model experiments in which the forces on submerged obstacles can be measured under proper scale considerations in water tanks such as we have described in the chapter on shipping.

The major problems which harass the hydraulic and the agricultural engineer in these days are those of erosion, the transport of eroded materials by streams and the silting up of estuaries and lower reaches where the soil is redeposited. The subject seems to have first engaged the attention of scientists some fifty years ago when Du Bois, a French engineer, found that the mass of silt carried by a stream could be expressed in terms of the shear exerted by the stream on its bed, which he equated empirically to the product of the specific weight of the fluid ( $= 1$ , on the metric system, for water), the depth of the stream, and the slope of its bed. A number of investigators have followed up this idea, but it really gives far too simple a picture of the processes going on. No two rivers give the same Du Bois coefficient—the factor relating shear to silt load—while in a single stream the factor varies from time to time.

To get a true picture of the dynamics of the phenomenon we need to delve more deeply into the mechanism by which individual particles are carried up from the bed into the stream. On the bed itself there is, of course, a frictional force exerted through the boundary layer of fluid which bathes it. The value of this force on unit area is determined by the viscosity of the fluid times the gradient of velocity at the bed. The extent to which the shearing force can shift an individual particle depends on the cohesion which subsists between that particle and its fellows, and on the pore space in the soil, for this latter largely decides the ease with which the fluid can permeate the soil. Once the fluid has invested the particle

in this way, it stands a much greater chance of overcoming its immobility, since the force then becomes a more direct push on the particle instead of a rubbing of its top surface. If the current can adequately penetrate beneath the grain, another effect, the Magnus effect, comes into play, tending to lift the particle into the main stream. Thus, suppose there is a large grain resting above the general level of the bed but supported by it. This is undermined by the current, but owing to the restricted space beneath and the prevailing velocity gradient the speed of the fluid below the grain is less than that which passes over it. It is well known that in such a situation a cross-force originates directed towards that side of the obstacle where the speed is high, that is, there is now a tendency to lift the grain into the current. If this lift exceeds the weight of the grain in the fluid, it will rise until it comes to a place where the diminishing velocity gradient and consequent reduced lift balances the force of gravitation on it. All the time it is being impelled downstream. In a static equilibrium, it would remain at this level as long as the velocity gradient there remained constant, but in fact it overshoots this position, and falls again to repeat the evolution *ad inf.* While, then, the largest pebbles are rolled along the bottom, the moderate-sized ones execute a series of long or short hops. (Still smaller ones remain in suspension all the time in a turbulent stream through a process to be described shortly.) The height and length of these jumps naturally depend on the specific gravity and size of the grains so that when they are all more or less of a size, the height of this 'saltation zone,' as it is called (from Fr. '*sauter*'), is fairly definite. In a river or on the desert it does not often amount to much, but over snow-covered terrain the light snow flakes readily hop to a height of several feet. Arctic explorers relate that in a wind a dog team at a short distance may be invisible while the driver's head and shoulders may be seen emerging above the wraith of driving snow. Often, too, this leaping by well-graded sand grains leads to the formation of regular ripples on a mobile bed, for they tend to rise and fall at definite places. Once these are established they act as jump-

ing-off and landing-places for all succeeding grains as long as the stream or wind speed does not vary.

If the stream is running above the critical Reynolds' Number, all the finer grains are held in permanent suspension by turbulent mixing. On the mixing theory the particles in a given stratum travel on the average a certain horizontal distance, called 'mixing-length,' before merging their identity in the stratum next above or below. (This division into strata is quite arbitrary, but, in the theory, is carried to infinitesimal limits.) This mixing length is an inverse measure of the degree of turbulence, and obviously depends on the vertical components of velocity fluctuations such as subsist in turbulent flow. The theory is formally similar to that of molecular diffusion. A dye let into the bed of the stream would gradually infuse the whole fluid if it were kept stationary or moving at such a slow speed that streamline flow persisted. In such a case the diffusing agency would be the kinetic or Brownian motion of the molecules themselves and would be interminably slow compared to that in turbulence. Only very light microscopic particles can be visibly affected by Brownian motion, but when turbulence sets in, the fluctuations of velocity transverse to the stream can carry fair-sized grains to considerable heights above the bed. In both cases, the force which limits their upward excursions is gravity. Eventually they reach a mean distribution such that the concentration of particles varies exponentially with height above the bed, at least over that part of the stream wherein the mixing length is constant. This was first shown for turbulence by Dr. Hurst. It had been demonstrated for molecular distribution earlier in the classical experiments of Perrin on colloidal suspensions. Hurst used, not a channel, but a suspension of graded sand in water contained in a tall cylinder. The sand was kept in suspension by a stirrer which agitated the water into rotary and at the same time turbulent motion. He found by removing pipette samples at different levels in the tank that the logarithm of the sand concentration was actually proportional to distance above the floor of the vessel, as theory demanded, and that the degree

of turbulence was roughly represented by the square of the speed of stirring. The author has repeated Hurst's measurements with a mixed sand in a rectangular glass tank and shown by mechanical analysis of the samples that the logarithmic distribution for *each* size still holds for the type of sand one would find in a natural river, but, of course, the coefficient connecting the two variables (log. conc. and height) is not the same for each size, the heavier ones congregating more in the lower strata of the river. It was also shown by passing thin beams of light athwart the tank to fall on a photo-electric cell on the far side that the light cut off by the suspension could act as a measure of the silt load carried in suspension at the level of the beam. This was an important conclusion from the point of view of the channel experiments to be described next.

The hydraulic engineer is, of course, concerned with the total quantity of silt carried in suspension. This will depend largely on conditions near the bed, and we may group the relevant influences as follows:

- (a) The velocity gradient perpendicular to the stream, and, in particular, its value at the bed.
- (b) The degree of turbulence.
- (c) The silt carried; the size, shape, and specific gravity of the grains.
- (d) The configuration of the bed, its slope and roughness.

In a natural stream all these factors intervene in a way which does not allow of the sorting out of their respective contributions. The author therefore proposed to study the transport of a loosely compacted sediment formed into a bed of as nearly as possible spherical grains of the same size and specific gravity before passing on to natural silt. The Reynolds' Number of the flow was to start from below the critical value and eventually exceed it. Apart from this, only the first factor would vary in a given experiment. The velocity gradient was to be measured by a calibrated hot-wire anemometer and the distribution of the silt across vertical sections of the channel was to be measured by the turbidimeter just mentioned, i.e. by the use of a narrow horizontal beam of light and a photo-electric cell.

The channel was constructed with plate glass sides 6 ft. long extending between two reservoirs of 10 cu. ft. capacity. The experimental portion was 1 ft. wide and allowed a maximum water depth of the same value. The two reservoirs were connected through a 3-in. pipe and a 2-h.p. centrifugal pump so that the water after spilling over a weir in the downstream reservoir was returned to the upstream one where it again passed over a weir before entering the channel. For the mounting of the lamp and photo-electric cell it was essential

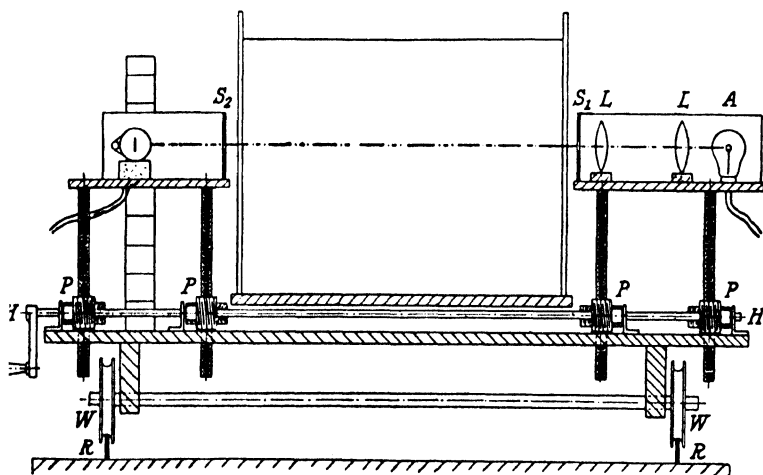

FIG. 34.—WATER CHANNEL FOR EROSION EXPERIMENTS

that they could be adjusted both vertically and horizontally without losing orientation. Fig. 34 shows a transverse section of the channel with the beam of light (chain line) for measuring silt concentrations. Light from the lamp, A, passes through the circular and cylindrical lenses L, L, and the adjustable slit  $S_1$  and crosses the channel as a narrow beam to fall on the cell after passing a second slit,  $S_2$ . By means of wheels rolling on rails, R, R, the whole apparatus could be moved along parallel to the axis of the channel. A handle rotating a long screw, H, H, served to raise or lower the pillars, P, P, P, P, through worm gears and so change the level of the light beam relative to the water without loss of orientation of beam and cell.

It had previously been shown that the extinction of light by silt and hence the defect of photo-electric current was proportional to the total projected area of the intervening particles, provided the concentration of the silt were not too great. This calibration was carried out by interposing a glass-walled tank containing various numbers of uniform particles, maintained in suspension by continual stirring into the beam of light.

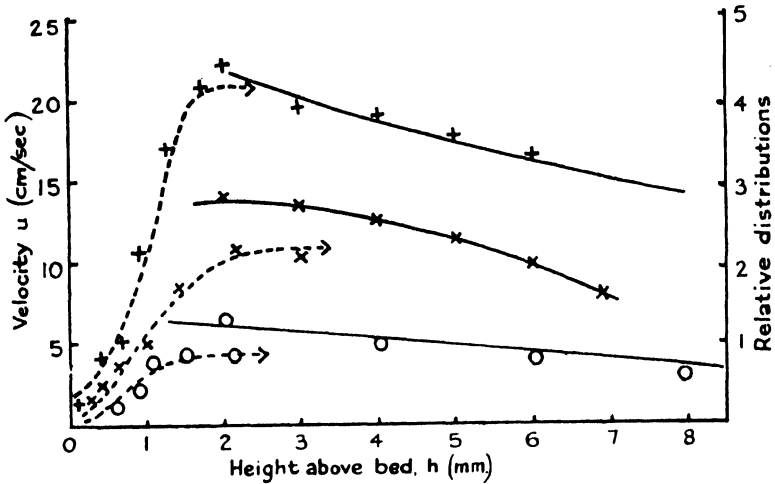

FIG. 35.—VELOCITIES (BROKEN LINES) AND SILT CONCENTRATIONS (FULL LINES) ABOVE BED OF ARTIFICIAL CHANNEL AT THREE DIFFERENT OUTFLOWS

A typical set of results showing the silt concentrations and velocity gradients for several mean channel speeds is shown in Fig. 35, with a bed formed of loosely compacted soil laid on the floor of the channel. In this particular case, the water readily penetrates the original bed. Within the saltation zone, the velocity gradient changes from a positive to a negative slope, indicating that within the mobile part of the bed the grains are rolling and jumping over each other in a manner that befits the action of a shear on a quasi-solid substance.

As far as silt concentration measurements in the channel go they confirm the logarithmic distribution of theory except within a centimetre of the bed, where, owing to the steep velocity gradient, the mixing length is not constant. It is, in

fact, well known from aerodynamic investigations that a thin stratum of fluid in contact with a solid boundary is in streamline flow even when the main flow outside is turbulent. This non-turbulent boundary layer still persists when the 'solid boundary' is changeable as it is in a river bed. Outside this region, which is barely penetrable by our instruments owing to its tenuity, there is another of extreme turbulence which eventually decreases in intensity to that characteristic of the main stream. Data deduced from measurements of the silt concentration in close proximity to the bed indicate that in the first few millimetres above the saltation zone, the mixing length rises in approximately linear fashion until it reaches a value which remains nearly constant until the free surface of the stream is approached.

The author has also carried out an investigation of the velocity and silt distribution in a section of a natural river, to wit, the Tyne at Newcastle, where it is tidal and is not only very turbulent at the half ebb but carries a measurable quantity of material—practically all inorganic—in suspension. A vertical traverse of the stream was made beside the piers of the Swing Bridge. The velocity was measured by an Amsler meter. This is of the torpedo form, the revolutions of the pusher screw when exposed to the current of the river being communicated to a counter on the dock above. For silt estimation a sampling bottle in a loaded can was let down at the same spot to various prescribed depths. The can filled from the top through an opening from which the cork was drawn by a cord when the bottle had reached the desired depth. To let the water with its suspended silt into the bottle with the least possible disturbance the air could only escape slowly through a vent as the water entered to take its place. The samples were submitted to mechanical analysis in the photo-electric apparatus which has been already described (p. 88) and the masses corresponding to each size ( $r$ ) plotted against depth (Fig. 36). It will be observed that these plots are nearly straight lines.

In a second experiment, an attempt was made to determine

the silt concentration *in situ*, using a photo-electric turbidimeter. To a piece of wood was fixed at one end a 6-volt lamp in a focusing tube—an ordinary galvanometer lamp and lens unit rendered watertight with a covering of pitch at the joints—

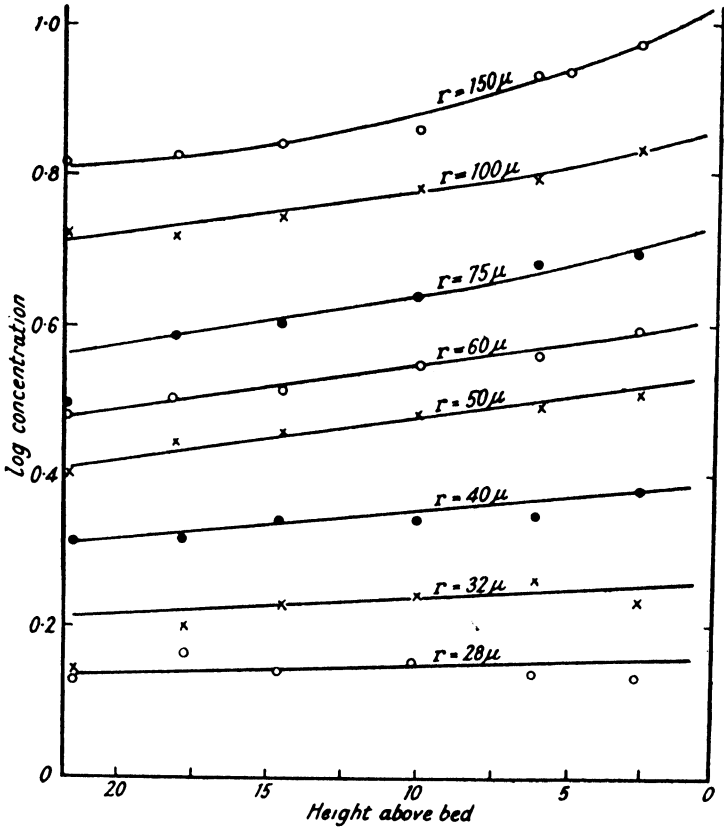

FIG. 36.—SIZE DISTRIBUTION OF SILT SAMPLES

and at the other end a photo-electric cell in a watertight case. To the centre of this wooden bar was fixed another at right angles to the first with a heavy weight on the end. When this T-piece was lowered into the water the sinker kept it in a vertical position with the aid of guy ropes to counteract the force of the current which tended to deflect the apparatus. In this

way the beam of light and the cross-bar remained horizontal. Connections led to a battery for the lamp supply and to a sensitive microammeter for the photo-electric current on *terra firma*. (The research was not completed without the usual vicissitudes which seem to accompany most excursions of the physicist outside his laboratory. A series of results would have to be given up to withdraw the apparatus from the river at the warning of the approach of a vessel; on one occasion

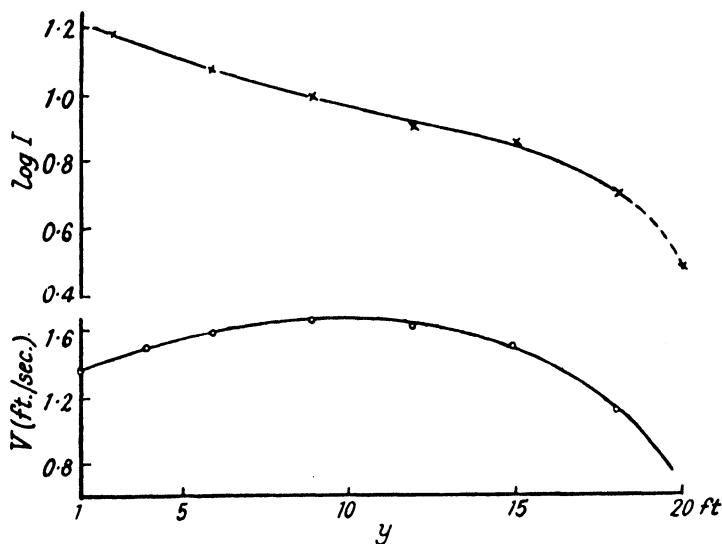

FIG. 37.—LIGHT INTENSITY: DEPTH CURVE (ABOVE) AND VELOCITY; DEPTH CURVE (BELOW) IN A NATURAL RIVER

neglect to take this precaution in time led to the apparatus being driven by the wash of a steamer beneath the piers of the bridge from which it could not be rescued—minus cell—until low tide; but eventually some uninterrupted series were obtained.) Measurements with this apparatus, correlated with velocity measurements on the same traverse, appear on Fig. 37. Again the logarithmic law is approximately upheld to within a few feet of the bed of the river, which was 20 ft. deep at the time. The values very close to the surface are not included, as they were affected by scattered daylight entering the apparatus.

The work of the engineer demands rather a knowledge of the total silt load carried by a stream past a certain point from time to time. This information can be derived with sufficient approximation for his purpose by the use of the two pieces of apparatus just cited, viz. (a) a current meter set where it is likely to record the mean current, and (b) a pair of turbidimeters set at two levels in the stream, say, at depths of one-third and two-thirds of the total depth respectively. Two assumptions must be made: (1) that the current meter reads the mean velocity at any time; for this purpose it is probably best to set the meter at one-third of the total depth; (2) that the silt distribution is logarithmic; the coefficient required to derive the total silt load from the reading of one of the turbidimeters is then known. This, multiplied by the mean current, then gives the silt transported past the observation station in unit time. The photo-electric cells will have been previously calibrated so as to read the actual mass of solid within the confines of the light beam at any instant. By the use of a number of such stations in the streams serving a watershed, it should be possible to correlate rainfall and soil conditions on the watershed with the daily amount of material eroded from it.

These points concern not only the river and harbour engineer but also the farmer. It is a matter of common knowledge that large tracts of farming land have been permanently lost to cultivation in Africa and America by over-cultivation and failure to consolidate the land. Manure not only enriches the soil but in the form of organic humus helps it to resist erosion. The extent to which different climatic and soil conditions affect erosion is only now being studied on a quantitative basis. For instance, some agriculturists think that the presence of fine colloidal material among the grosser soil crumbs helps to resist erosion, whereas others claim to find equal losses for soils exposed to the same weather but with widely differing colloid contents. Burning scrub to free an area for subsequent cultivation—a practice among the natives of Africa—is, however, generally agreed to be a pernicious usage. Fortunately,

the problem does not worry the British farmer at the moment, but in the United States work on the measurement of erosion, with or without the exercise of preventative measures, is a pressing need and is being taken up by the Soil Conservation Service of the Dept. of Agriculture in experimental projects all over the country.

These are in the main of two types. In the one the rainfall on straight slopes is correlated with the retained soil moisture and the amount of silt removed by it; in the other the run-off from a specially fashioned terrain is correlated with the rainfall on the whole of a small watershed of which it forms a part, in order that the efficacy of schemes for soil conservation may be studied. One of the most up-to-date of the former stations is to be found at Marlborough, New Jersey. The author had the privilege of inspecting the work there in the summer of 1938. Unfortunately, his visit preceded by one day the arrival of the great hurricane which broke several weeks of low rainfall; a day or two later the run-off would have been more spectacular, though less comfortable to scrutinise!

Here a field is divided up into strips running down a gentle slope to water and soil catchment bins. At the bottom of the slope a 6-in. brick course resting on a metal sill runs right across and leads to a large rectangular tank. At the far side of this tank the upper portion of the water overflows through a Gieb divisor to another circular tank. The divisor is merely a set of vertical slots of equal area and of any odd number between 5 and 11 according to circumstances, of which all but the centre one lead to waste. The silt sample from the remaining slot settles in the second tank where it is collected and weighed after every storm potent enough to cause run-off. Fig. 38, Plate III, shows several strips at the Beemerville Station located at Sussex, N.J., and the apparatus at the bottom of one of them. The object of the first tank is to catch the heavy particles of grit, sand, etc., before the silt passes on, since from the farmer's point of view it is the loss of fine silt and colloidal material that is detrimental to the soil; the grit need not be considered. (One should add

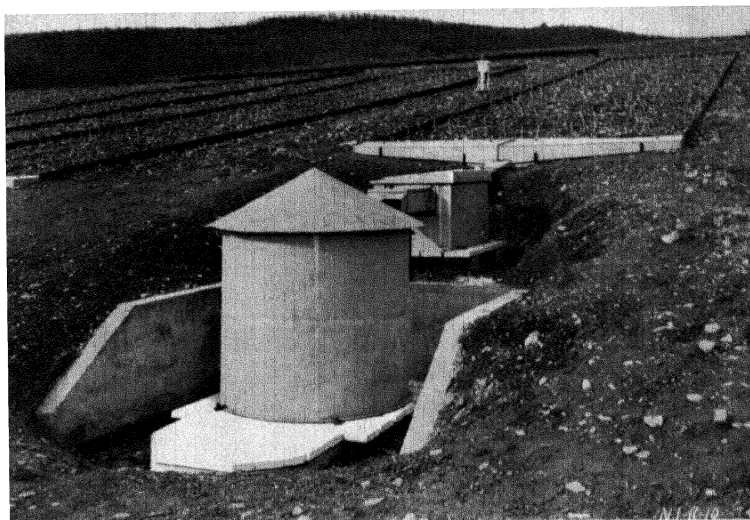

FIG. 38.—SILT RUN-OFF METER AND EXPERIMENTAL PLOTS, NEW JERSEY  
*(U.S. Soil Conservation Service)*



FIG. 39.—CHECK DAMS IN RIVER TO PREVENT EROSION OF BED, SWITZERLAND

PLATE III



that the soil in this part of New Jersey is a friable sandy loam, easily penetrated by rain and becomes a network of little gulleys after a light rainfall wherever it has no crop cover to protect it.)

The strips on the station vary in both length and pre-treatment. Some have been manured, while others are practically virgin soil. Some have had a cover crop, subsequently dug in. Yet others have had both treatments. The acidities of the soils have been reduced to the same value by liming. The experiments are in duplicate, and there are 'dummy' strips left between the experimental ones, which are cut off by low metal barriers from infiltration from the sides (cf. Fig. 38). It must not be assumed that if the length of a plot is doubled, twice as much run-off will ensue. The water falling higher up the slope may sink in and not cause so much erosion as if it had but a short distance to trickle down to the tanks. Naturally, the prevailing moisture content of the soil before the onset of further rain materially influences the amount of damage done. To keep a record of this, moisture meters of the Rogers type are embedded in the soil at the top end of several plots. These consist of 6-in. cups of light porous clay which swell or contract as the surrounding earth changes its moisture content. These tensiometers are connected to pressure gauges above the ground in the form of simple liquid manometers or automatic and continuously recording aneroids. The research has not yet proceeded long enough to enable results to be reported, but it is expected that after a few years' working, such stations will give the first detailed statistics of 'sheet' erosion, such as occurs on gently sloping agricultural land, as opposed to that more persistent erosion encountered in rivers and canals.

The second type of soil conservation project—of which a recent example is to be seen at Freehold, N.J.—is concerned with the measurement of run-off from a number of watersheds of moderate size (*c.* 100 acres). Formerly estimates were made in relation to a large watershed in which a variety of conditions existed, e.g. that of the Missouri, or else from an artificial and

stereotyped plot of laboratory size, just an acre or two. The object of this new research is to measure the effect on the watershed of schemes to improve the water-retaining capacity of the land and to protect it against erosion. All the water running off the land must be made to pass down through a single channel wherein a concrete weir is erected. Some of these weirs have a simple notch with sides inclined at constant angles, but in others the inclination of the sides of the V increases towards the vertex in order to increase the sensitivity of the instruments when recording low rates of flow. On the upstream side of the weir an instrument is housed which gives a continuous record of the position of a float on the surface of the water. A weir of the same shape will have been previously calibrated in a hydraulic laboratory so that the current over the weir corresponding to each position of the float is known. A number of rain gauges are dotted about the watershed in order that run-off may be compared with precipitation. At present only water losses are measured at this station, but it is proposed later to install photo-electric turbidimeters in the stream just above the notches so that silt loss from time to time may be recorded as well.

It is intended to collect data from these stations—which are more natural than the laboratory-like strips of the first projects, though each gives its quota of scientific information—which shall be of use in advising farmers confronted with losses on soils and terrains similar to one or other of the controlled watersheds. Only four amelioration schemes are being studied at the Freehold Project, but large numbers are distributed up and down the States, covering all types and sizes up to that of the largest farm or ranch.

Of the practices adopted to combat sheet erosion on farm land, the chief comprise (1) the planting of covercrops, when the field would otherwise be lying fallow, (2) strip cultivation, (3) ploughing along the contour, with terracing where necessary. Erosion is most active where there is nothing to break the flow of water or the passage of wind, so that the full shearing action of the fluid is felt on the surface of the soil itself. Thickly

sown grass or some similar plant will impede the velocity of flow over the ground itself ; then the paramount fall in velocity which gives rise to the shear is experienced by the upper parts of the stems of the crop where it cannot do much harm. At the same time, the water on the ground itself cannot run away so fast and stands a greater chance of percolating to the roots, which assist the conservation process by holding the soil together. If, however, the plants are tall and form dense undergrowth, the plots may become waterlogged and suffer from a superfluity of moisture. What the engineer requires is a scheme which will keep the shearing force on the ground small and allow moderate percolation while not impeding unduly the run-off above after a heavy storm. In a river this may be done by erecting a series of check dams or shallow weirs at short intervals (cf. Fig. 39, Plate III). In this way the stream is let down a sort of gentle staircase. So the main flow is unobstructed while the water on the bed is almost stagnated. Such devices are employed on a number of alpine rivers on the continent of Europe.

The second palliative for sheet erosion, that of strip farming, is intended to protect land under more open crops such as roots and tubers by interplanting with alternate strips of a better cover such as grass or corn. It has at best but a partial success and certainly is useless on steep fields. In the latter case, it is better to throw up shallow terraces along the contours of the hill and plough in the space between so that the furrows likewise run along the contour. In the latter end of the last century, Priestly Mangum introduced the broad shallow type of terrace which is named after him. It is about twenty feet broad and a foot high in front, being made by throwing up a levée of earth to direct run-off to the ends of the field where what has escaped absorption runs away in drains. Another type of terrace—the Nichols terrace—has a definite ditch on the uphill side of the levée and produces superior drainage but inferior percolation to the Mangum terrace. Both, of course, conserve the soil in preventing rapid drainage directly downhill. The terraces are cut by a special rotary disc plough, which throws all the earth

removed from the ground to one side, thus making mound and ditch in one and the same operation. At the experimental hydrology stations which we have described all effluent from terraces is naturally passed to the single outlet, over the weir.

The economics of the amelioration schemes as carried out in the United States is interesting. The experimental grounds on which the plots are located are not owned by the State in which they lie. A co-operative agreement is drawn up between the State and the farmer, by which he consents to follow a schedule of cultivation for a number of years (at least five), to admit officers of the Soil Conservation Service when they require to attend to the instruments and to use only fertilisers prescribed by the Department. In return he gets the services of their engineers for making terraces, drainage culverts, and every appurtenance of the system of erosion control and measurement which they deem necessary for his land. Most of the unskilled labour for these constructions is supplied from the camps of lads which under the name of Civilian Conservation Corps have been set up in many localities to take on public works and to help to relieve unemployment. Their services are available without charge to the officers of the S.C.S. and apparently are paid for by the Federal Government. The farmer, of course, supplies the necessary seed to fulfil the scheme and reaps the crops himself, but there is often a clause inserted in the contract to prohibit autumn ploughing as erosion is rife at that season and downhill furrows particularly will aggravate it.

In this account of the silt problem we have concentrated mainly on those aspects that concern soil conservation, i.e. sheet and gully erosion, but we must not overlook the fact that the same process is going on at the coast and on the sea bed. At the coast it is mainly wave motion in the breakers that is responsible for undermining cliffs and redepositing the eroded material elsewhere. In a number of places the losses balance the gains over a period of years, but in others the lack of shore protection and the strength of ocean currents causes losses in excess of what is returned. If the force of waves and intensity

of currents are broken by frequent groynes or breakwaters, then the coastline gradually advances towards the sea; indeed, the original groynes may be completely covered with shingle and sand a decade after their erection.

Silt measurement in the ocean is hampered by difficulty in sorting out the inorganic from the living matter. Of course, one can take samples from the sea, evaporate to dryness and ignite, subsequently redispersing the residue in clean water to make a mechanical analysis. Such analyses, together with microscopic observation of the particles in suspension, are valuable to geologists and oceanographers, who are often thus able to ascribe a distant origin to the sediment and so derive information about the trend of ocean currents in the vicinity. The quantity of solid matter carried in suspension in seas and deep lakes bears an important relation to the life therein, since it determines the extent to which daylight can penetrate.

Latterly, measurements have been made of the proportion of light penetrating the sea to various depths below its surface by means of photo-electric cells, sunk face upwards in the water. The photo-electric current so recorded gives an integrated estimate of the extinction of light due to all the solid matter in suspension down to the point at which it is placed, together with that natural to the molecules themselves that make up water. Another kind of variation in the records of the cells is noticed with conditions at the surface, where light is always reflected, but more on a rough day, due to the formation of air bubbles, than when the surface is untroubled. The cell also collects light from quite a wide cone from where it lies up to the surface. With these reservations, the transparency measurements fall into line with those which one would get if a simultaneous set of observations were made with the artificial light beam and *shielded* photo-electric cell, such as we have described earlier in this chapter.

#### SOURCES

W. R. Atkins and H. H. Poole: "Photo-electric Measurement of Light Penetration in the Sea" (Phil. Trans. Roy. Soc., **222B**, 129, 1933).

Q. C. Ayres: "Soil Erosion and its Control," 1936.

Imperial Bureau of Soil Science: "Erosion and Soil Conservation," 1937.

T. E. Pryce-Tannatt: "Fish Passes," 1938.

E. G. Richardson: "Transport of Silt by Turbulent Streams" (Proc. Roy. Soc., **162**, 583, 1937).

— "Erosion and Soil Conservation in Theory and Practice" (Science Progress, **34**, 63, 1939).

### JOURNALS

Trans. Inst. Civil Engineers; Trans. Inst. of Water Engineers;  
Rep. U.S. Soil Conservation Service, Dept. Agric.

## CHAPTER IX

### PHYSICS DOWN THE MINE

THE operations in mining, requiring as they do so many precautions and danger signals, are eminently suited to the employment of relays. These are most conveniently worked by a combination of photo-electric cell and thermionic valve. The general principle of such an apparatus is as follows: a beam of light shines across an open space on to the cell, something comes into the path of the light and this lowers the current through the cell. This current passes through the coil of a small electromagnet, which normally holds a switch in position against a spring. The reduction of current causes the switch to fly over to the other position and this operates the alarm or performs some precautionary duty.

The current from a photo-electric cell in most cases is small, and although relays and alarms using little current are obtainable, some amplification of the current is required if heavy relays are to be operated. A simple amplifying circuit using an ordinary wireless valve is shown in Fig. 40. A is the accumulator feeding the filament F, B is a dry battery connected in series with the photo-electric cell C and the grid G of the valve. A relay R and a high-tension battery H are connected between the plate P and the filament. When the cell is dark it is uncharged and the positive grid bias is sufficient to maintain the ordinary anode current of the valve through R and H; the relay is therefore held in the 'off' position. When light shines on the cell its potential opposes that of the grid battery making the grid negative to an extent sufficient to stop the anode current and the relay flies 'on.' If the cell is normally to be illuminated and darkness is to operate the relay, the connections to the cell terminals are transposed so that the cell current aids the grid battery. Note that in either case

failure of any part of the circuit causes the relay or alarm to work, and in the latter case failure of the lamp works in the same way.

Below we give instances of the simple direct use of such relays.

The counting of tubs coming out of a pit is a straightforward application of the simple circuit. At some point a beam of

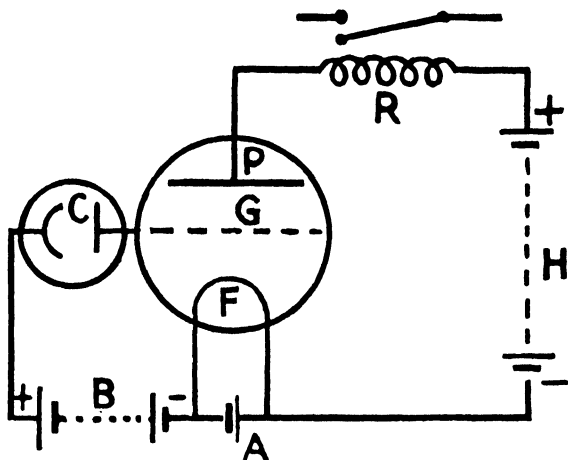

FIG. 40.—PHOTO-ELECTRIC RELAY CIRCUIT

light crosses the rails to fall on the photo-electric cell, so disposed that the relay cannot be operated by diffused daylight but requires the full current due to the bright light from the lamp to work it. Each time a waggon cuts off the beam the relay functions and moves the cog-wheel of a counter. A refinement of this device involves passing the beam of light just across the top of the tub, so that if the mineral were heaped a little above the top the relay would operate, but empty tubs would not be counted.

Overwinding of the steel ropes which hoist the cage containing men and tubs up or down the shaft is dangerous, particularly at the surface end, where the cage has been known to pass through the roof girders, break the ropes and fall to the bottom. Even at the bottom of the shaft men in the cage may be injured

by its stopping with a bump. Normally brakes come into operation before the ends of the run are reached. Prevention of overwinding is easy to arrange if the beam of light passes just over the highest permissible position of the cage. By the use of a relay, sufficient current would be available to trip the engine gear as soon as the beam of light were interrupted.

The winding-ropes themselves could be tested for faults, by making a section pass over pulleys one on each side of a hole through which the beam of light passed on its way to the cell, the device being incorporated in the winding-gear near the drum. If now a frayed section passed the hole, enough light would be let through to operate a warning light or bell. It would naturally be desirable to duplicate this apparatus by passing the rope through two light beams at right angles one above the other. It is conceivable that a fracture in one particular azimuth might not affect one beam, but would scarcely fail to be detected by the other. This apparatus could not of course be applied to that part of the rope which in working was always on the drum, nor would it indicate a defect in the core if the outer strands remained intact.

Devices giving overload and underload warnings are legion. They can be applied to any instrument involving the motion of a hand over a dial. The instrument is pierced by a hole through which the light passes at the maximum—or minimum—permissible value. When the hand reaches this position it cuts off the light. In this way a boiler has been automatically fed with water; when the water in the gauge falls too low the relay turns on a supply.

Finally, smoke from a fire or faulty combustion in a furnace is readily detected by photo-electric means. One disadvantage here is that the glass covering the cell may itself become coated with soot. This can be overcome by the use of mechanical wipers. In this connection—smoke detection—the flicker arrangement shown in Fig. 41 is useful. By means of a system of mirrors, light from a source L passes by one of two paths (shown dotted) on to the photo-electric cell S. One of these paths lies almost entirely through the unadulterated air in the

tube, TT. The other is exposed to the atmosphere of the mine, AA. Each path is opened and shut alternately by the disc D which is driven by the motor M and has equi-spaced slits and stops round its circumference. As long as the air in the mine is the same as that in the protected tube the light received by the cell remains constant, but if the outer atmosphere is murky or dusty, less light will fall on the cell when the path AA is open than when TT is open. A fluctuating current then passes through the circuit of the cell, and this—after being amplified—is passed into a loud-speaker which gives out a note whose intensity is a rough measure of the smoke opacity or dustiness of the atmosphere in the pit. Thus this ingenious

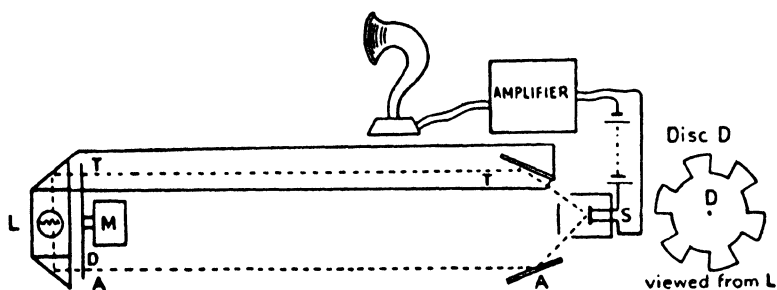

FIG. 41.—FLICKER WARNING DEVICE

instrument gives its own audible warning, the pitch of the note being determined by the rate of revolution of the disc and the number of slits. This is the same principle as that by which talking films are reproduced.

Photometers for the testing of electric lamps are now operated on the photo-electric principle (*vide infra*, p. 223). Not only are miners' lamps tested in this way as they come 'out-by,' but all types of workers can have their local illumination tested with such an apparatus to see if it is adequate for the work they have to do.

The reader will be wondering whether the versatile photo-electric cell can be used for the detection of poison-gas. This is possible provided that colourless gases can be made to change the colour of solutions in open vessels or painted

patches from which light is reflected on to the cell. Carbon monoxide would not raise difficulties, as the black coloration which it produces in ammoniacal silver hydrate or in an iron peroxide solution would serve to interrupt the beam of light and ring an alarm provided the concentration of the gas were sufficient. Sulphuretted hydrogen liberated in certain industrial processes may also be detected by the blackening of a lead salt in conjunction with a photo-electric cell. Methane or fire-damp is a more difficult customer, as it is so inert. One cannot readily think of a reagent that it could be made to act on. For this work the Thornton gas-detector is better suited.

This is a simple accessory to the electric lamps, which—complete with battery—is usually carried by the pitman. The old miner's lamp (due to Sir Humphry Davy) is well known. An oil-burning flame was totally enclosed by a piece of fine-mesh gauze and the airtight structure of the lamp itself. The gauze, in virtue of its good heat conductivity, failed to allow the dangerous mixture of air and methane which might come to the lamp from outside to reach ignition temperature, in spite of the exposed flame. At the same time a rise in the percentage of methane in the mine atmosphere above safety level was indicated by its slow combustion in the lamp turning the flame blue. The Davy lamp is obsolescent. It would have been replaced by electricity sooner had not the Government inspectorate been afraid of the dangerous possibility of sparking at open contacts. In Professor Thornton's device a shielded filament electrically heated inside the case of the lamp, to which the mine atmosphere can penetrate, is looked at through a glass window. If methane or carbon dioxide is present, the electrical resistance of the filament is lower and higher respectively, consequently it takes a different current and changes colour. In making an estimation of the noxious gas content of his surroundings in the pit, the miner matches the colour of the filament with a standard one, whose atmosphere does not vary since it is shielded from outside, but whose appearance can be changed by interposing a series of colour filters between it and the eye until the best match is found. When this has

been done the approximate proportions of adulterant can be read off on the filter disc. It will be noted that the basic principle is the same as that of the katharometer, the instrument by which a gaseous mixture is analysed in respect of the change of resistance of a heated platinum wire. In the latter case the change of resistance is found by noting the deflection of a galvanometer in the circuit. The katharometer has, in fact, been used in a mine for estimating the hazard in gas contamination to be expected at a distant point in the workings, the galvanometer then being set up at the bottom of the main shaft and connected by leads to the distant instrument.

Another pregnant source of accident in a mine is to be traced to the cloud of dust set up by the coal-getting and which may be carried in suspension by draughts. The danger is partly one of explosion, partly one to the health of the workers. The latter achieves its most deadly form in the disease of silicosis, a form of consumption which attacks miners in certain areas and is ascribed to fine particles (less than one-tenth of a micron) of silica, which are drawn with the air into the lungs. Outbreaks of fire in mines are said to be due to floating particles of coal dust in which the larger particles are concerned, up to twenty microns. Both these hypotheses are by no means surely proven, since research has not gone far enough into these regions yet. The usual method adopted in the pit for precipitating dust is by injecting fine sprays of water into the atmosphere. This does not tackle the job too effectively; moreover, it increases the humidity of an already overheated atmosphere to the degree at which it seriously inconveniences the men working in the vicinity.

Dust may also be laid by electrical means. If an electrical potential between two metal plates is set up, any dust particles floating between them become charged and are then driven by the electrical field towards one or other of the charged plates. This method, invented by Sir Oliver Lodge, is used in cement works and a number of chemical factories for the precipitation of dust. In particular, it finds a use in smokestacks in areas where the operating company is forbidden by law to

permit noxious smokes to pollute the atmosphere. The potential is so applied that the smoke particles driven to the charged plates either fall to the bottom of the chimney when a sufficient quantity has caked together, or are periodically brushed off when that particular chimney is idle. The Lodge method could not, however, be employed in coal mines owing to the risk of explosions being initiated by the electric charges or of sparks jumping between the plates.

To study the size distribution of mine dusts or to test the efficacy of such precipitation methods the ubiquitous sedimentation meter may be used, with the proviso that the sedimentation takes place in air; for the rate of settling in water is too tedious to follow. Settling in air could well be followed by photo-electric means, but convection is much more difficult to inhibit in a gas than in a liquid. The table below gives the times taken by silica particles of the sizes specified to fall through one foot in air and in water respectively at a temperature of 60° F.

<i>Size in Microns</i>	<i>Air</i>	<i>Water</i>
10	36 secs.	20 mins.
1	54 mins.	33.3 hrs.
0.1	90 hrs.	140 days

The only hope of getting particles less than one micron to record themselves by sedimentation in a liquid is to enhance the gravitational acceleration towards the base of the tank. This can be done by having the specimen of dust in a glass-walled cell and whirling it round in a high-speed centrifuge, stopping from time to time to make a photo-electric turbidity measurement at a fixed depth in the cell. Professor Svedberg, in his well-known apparatus for measuring the molecular weight of protein and other large molecules from their rate of sedimentation, is able to accelerate them at a rate one hundred thousand times that of gravity, such is the power and precision of construction of his centrifuge. For these grosser dust and smoke particles an acceleration one hundred times that of gravity would suffice.

In taking samples of dust from a mine for examination, a few cubic centimetres of the mine atmosphere are sucked into a glass-walled chamber and driven by the force of the aspirating air current against one of the glass windows, where an observer tries to count the number on a reticule, made of a hundred little squares, based on one-tenth of a millimetre as side, ruled on the object glass of the microscope.

A new type of sampler has recently been sanctioned by the British Government for obtaining mine-dust specimens. A thin wire, electrically heated, is stretched between two vertical and parallel microscope cover slips. The dust in the air drawn through it is repelled from the hot wire and deposited on the cold glass strips, where it may be examined. The instrument has this advantage over the one just described—that it catches practically all the dust particles between 5 and 0.1 microns in the air passing through it, whereas the former one favours the larger ones to the detriment of the smaller and disease-causing motes. (The origin of the effect, by which dust and smoke particles are repelled from a hot to a cold surface, is still obscure. The same effect may be seen in operation where a black smudge collects on a wall over a radiator.)

Investigations of the propagation of compressional waves through the upper strata of the earth, both for locating a distant source of such disturbances and for gaining information by the use of such a source of the formation and properties of the upper strata of the earth, have run parallel to submarine and aerial researches. In order to locate the position of enemy saps relative to the trenches, the engineers of the French Army evolved a special type of microphone called the geophone.

This is constructed on the same principle as the seismographs for registering earthquakes. A cylindrical leaden weight (about two inches diameter, half an inch deep) is connected by its circumferential edge to a case, airtight save for a stethoscope connection to the user's ears, confronting one face of the lead weight. The case is embedded in the soil or placed with one face against the rock. Disturbances coming

through the ground cause the more or less elastic case to move with them, but the inner lead weight remains comparatively unmoved, because of its large mass and because it is, as it were, suspended within the case. This relative motion of the lead and the case causes compressions and rarefactions of the enclosed air, which are apparent to the ear at the end of the stethoscope tube. The apparatus can also be made self-recording. For direction-finding purposes, a pair of geophones a few feet apart are employed on the binaural principle, each having a connection to one ear, so that the listener can tell with fair certainty whether the subterranean source lies to the right or left of a line at right angles to that joining the two geophones, provided that the stratum between source and receiver is homogeneous, or at least that no refraction of the waves in their path has taken place.

This instrument is now being used in connection with sound propagation for mine rescue work. Should miners be entombed alive by a fall of earth, the direction in which rescue operations are to work is determined by finding the direction from which tapping by the entombed men appears to come. For this purpose, the sufferers in the mishap have been instructed to deal successive blows on some hard object, as the coal, rails, or pipe-line. Discontinuities, either in the form of 'rooms' in the mine containing air, or faults, or veins of clay, considerably reduce the distance to which blows on the ore are propagated, besides impeding direction-finding by refraction of the sound.

A suspended pipe-line is one of the best media for transmitting such sounds in a mine, but its conductivity to sound is hampered if a considerable length has been covered by a fall of soft earth. Under these circumstances, the contents of the pipe, gaseous or liquid, used in speaking-tube fashion, offer superior conductivity to sound. Incidentally, if the fall has ruptured such a pipe or other metallic conductor, the position can be approximately located from the 'safe' end by timing the echo from the break after tapping the metal—another application of sound propagation which goes back to the early

days of the pneumatic post. The geophone is also used for finding the bearings of water leaks in disused galleries, or of other water percolating in a mine, or even from a street main, if the latter operation is conducted in the early morning, using the trickling of the water as source of sound.

To turn to the second type of sound employment in the earth; the 'prospecting' of subterranean strata by the echo reflected from their boundaries has been developed by the Erda firm in Göttingen. Details of the method are still trade secrets, but the principle of the method seems to be as follows. Fig. 42 represents two strata, the upper one of soft material and the lower of hard material, in which the velocity of a pulse is

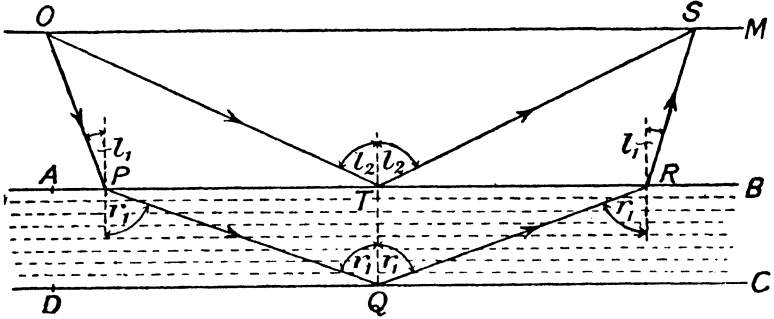

FIG. 42.—ECHO-PROSPECTING

considerably greater than in the upper stratum. Let O be the source of such a pulse, sending out a spherical wave in the upper stratum, and imagine a geophone or similar detector to be placed at S. The disturbance can generally reach S by three paths: (1) directly along the surface OS; (2) by reflection at the boundary between the two strata, e.g. OTS; (3) by refraction at A at the same boundary, and subsequent reflection on the lower boundary of the hard surface and back to the upper stratum, e.g. by OAQRS.

Ignoring the surface wave which arrives first, the second and third waves will in general arrive at S at different instants. If S is close to O the once reflected wave will arrive before that which has penetrated the lower stratum. As S is removed

from O, there will come a position of S for which the latter will arrive before the former, in spite of the longer path it has had to traverse, on account of its considerable course with the greater velocity in the lower stratum. If, then, we gradually move S away from O, and again ignore the first-arriving surface wave, the time of arrival via the bent path will grow regularly with the distance OS, until suddenly it begins to increase faster, indicating that the refracted wave is now gaining on the other. The existence of such a 'kink' in the distance-time curve along the surface is a sure sign of a harder stratum below, maybe of valuable ore. By measuring the times of the two echoes and by binaural direction-finding of

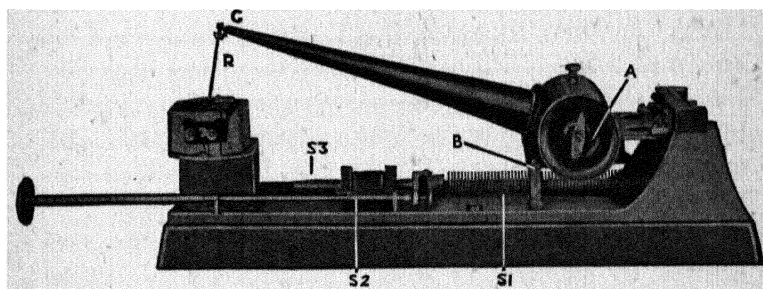

FIG. 43.—SEISMOGRAPH (*Cambridge Scientific Instrument Co.*)

the returned echoes TS and RS, it is possible to estimate the depth and velocity of sound in the hidden stratum, and therefore a guess can be made as to its composition. Such 'echo-prospecting' methods promise to save indiscriminate digging for ore, and are also applicable, with suitable appliances, to prospecting a sea- or lake-bed.

Fig. 43 shows a modern form of seismograph in which considerable magnification of the movement, both mechanical and electrical, set up in the instrument enhances the sensitivity of the instrument to weak earth tremors. The mass A can rotate about the pivot B against springs S1, S2. At the end of the lever arm C is a light rod R whose movement will cause rotation of a coil within the permanent magnet at its lower end, so exciting a proportionate response in the electro-magnet

below R and in a sensitive galvanometer (not shown on the figure). The latter is an Einthoven string galvanometer of the type used in recording heart currents, and the motion of the 'string' therein caused by the momentary current set up by the tremor is again magnified, when it is projected by a powerful source of light on to a viewing screen, or the moving film camera which is used in place of the screen when it is desired to get a continuous record of all shocks picked up by the instrument.

The example of the use of seismographs or geophones which we have given in Fig. 42 is a very simple one. In actual practice the record may be complicated by the strata being inclined in one direction or another and by the presence of 'faults' involving a sudden drop or rise in the level of the unseen rock which is being studied by the echoes it returns. Even so, with a sufficiency of patience and records it is possible to plot out the configuration of the underground stratum with fair accuracy. Such data have in most instances been confirmed by subsequent boring.

While the method of echo-prospecting remains the most accurate for plumbing or probing the hidden depths of the earth's crust, the apparatus is expensive and delicate. A simple and portable apparatus is preferred when it is a matter of finding 'how the land lies' rather than of accurately delineating its subterranean geology. The most favoured of these by oil prospectors at the present time is the gravity balance, which depends on the fact that a suspended mass tends to move in that direction towards which it experiences the strongest attraction. If the balance is placed over a perfectly uniform subsoil, the force of gravity is the same everywhere so that the masses forming the balance arms are unaffected, but if there are inequalities in density in the neighbourhood there will be a gradient of gravitational attraction to or from the denser parts. The masses on the balance arms are placed unsymmetrically with reference to the case, one mass being higher up than the other, consequently there is a force proportional to the gravity gradient tending to deflect the system.

For instance, in prospecting for oil, the problem resolves itself into locating the 'domes' of salt which usually overlie the oil-field. The soil in the dome being less dense than the average soil found in those parts betrays itself to the prospector as a diminution of the strength of gravity in its vicinity. As the surveyor passes with his balance along the surface, making periodic halts for readings of the instrument, he encounters a gradient of gravitational force on approaching the dome from one side and leaving it on the other.

The balance commonly employed for detecting such anomalies in the earth's gravitational attraction is the Eötvös torsion balance. It consists of two

masses of platinum or gold each weighing 25 grams attached to a rigid aluminium rod 40 cm. long, itself suspended in a horizontal position by a thin platinum wire of about the same length from a point at the top of the case. Whereas one mass ( $M_1$ , Fig. 44) is directly attached to one end of the aluminium rod, the other ( $M$ ) is suspended on a wire from the other end of the balance beam so as to hang 60 cm. lower. As long as the gravitational attraction over the balance is truly vertical (as it would be over level and perfectly uniform ground) there is no tendency of the arm to twist, but if the force of gravity is inclined from the vertical, and, moreover, inclined to

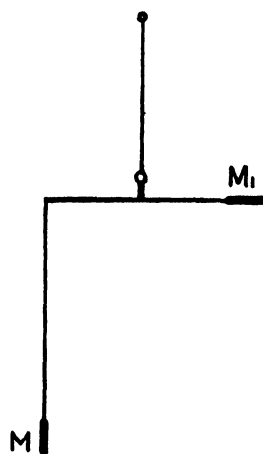

FIG. 44.—DIAGRAM OF EÖTVÖS TORSION BALANCE

different degrees at different levels over the balance case (as it would be, for example, if a large lump of lead were held in the neighbourhood), the horizontal tendency of the earth's attraction is not the same at the respective levels of the two masses and the system will twist a little about the suspension wire. Naturally the instrument must be very carefully levelled and screened from draughts, and as the deflection is small

and the near presence of the surveyor would disturb the setting, he reads the deflection through a telescope.

In an instrument which works in a somewhat similar manner the torsion bar and masses are replaced by a magnetic needle so suspended as to lie horizontal in the earth's magnetic field as generally prevailing in the district in which it is employed.

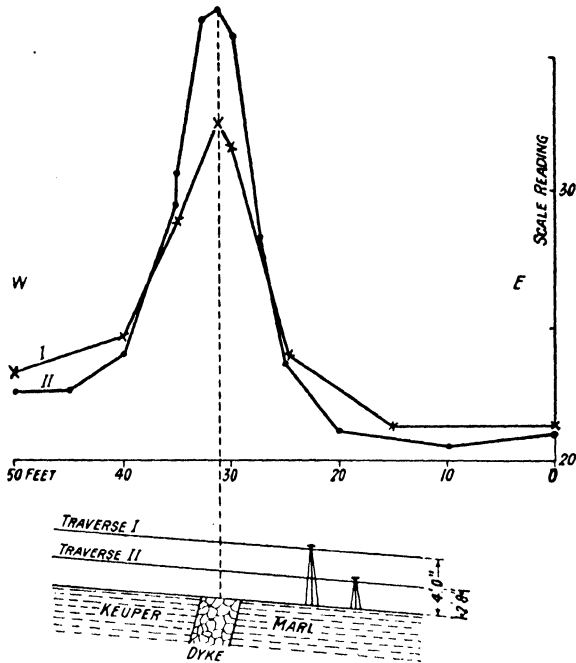

FIG. 45.—RESULTS OF MAGNETIC TRAVERSE OF A DIKE (Whetton)

The instrument is set up and levelled with the zero line on the horizontal scale over which the magnet is suspended turned through a right angle from the magnetic meridian. The magnet swings into equilibrium in the meridian and points to a division on the scale close to  $90^\circ$ . Its actual position on the scale having been read, the case containing the scale is turned half round so that the line of zeros on the scale is now  $90^\circ$  out of the meridian on the other side, and the division over which the needle comes to rest is again read off. In a

perfectly uniform magnetic field, the reading on both occasions would be  $90^\circ$ ; but if the vertical component of the earth's magnetic field—due to iron or other magnetic ores in the neighbourhood—differs locally from the standard value for which the instrument was set, the two readings will not agree. By plotting the 'magnetic anomaly' as a traverse over a mineral field is made with the instrument, the disposition of the ore beneath may be surmised. This method is, of course, best suited to the tracing of veins of magnetic ore such as those of iron. Fig. 45 (after Whetton) shows two traverses with the magnetic apparatus across a visible 'dyke' of ironstone with the needle kept at 2 feet 8 inches and 4 feet respectively above the surface of the ground. The sharp increase in magnetic anomaly as the instrument passed over the dyke is obvious. The inclination or 'hade' of the dyke to the vertical accounts for the difference in shape of the two curves which have been plotted through the observations. If the dyke had been truly vertical, the curves would have been of similar shape on each side of the central line; moreover, one would have been a smaller copy of the other.

The final method to be described is based on measurement of the electrical resistance of portions of the earth's crust comprised between two metal electrodes pushed down into the soil. If the tips only of the electrodes are exposed to the soil while the rest of the posts are insulated, it is possible to make measurements of resistance at different depths below the surface as far as the electrodes can be driven down or sunk in bore holes, a feature not possible with the gravity or magnetic instruments. To avoid 'polarisation' an alternating current must be used and the resistance is conveniently read off on a portable resistance-testing outfit in which some form of Wheatstone bridge is connected with a hand magneto to provide the necessary source of current. The results are a little difficult to interpret without independent witness on the geological side.

Whetton, who has used both electrical and magnetic instruments in the Northumbrian coalfield, finds the latter more exact, although the electrical test is convenient for obtaining

less accurate results over a wide field in a comparatively short space of time. It is particularly useful in locating and tracing coal measures, since the specific resistance of coal shale is much higher than that of the sandy shales or limestone in which it is found inserted. One disability in its use is the fact that water—especially water containing salts in solution—considerably changes the resistance of any soil stratum in which it is present. Even if water is known to be absent, one of the difficulties which still remains is to settle on a figure for the specific resistance of the different types of soil, without which the results cannot be quantitatively interpreted.

The different types of prospecting apparatus thus group themselves according to their respective usefulness as follows: the seismic and gravity methods for oil prospecting; the magnetic for iron and other magnetic ores; the electrical for coal. Enough has been said, it is hoped, to show that geophysical surveying is a rising and important branch of applied science.

### SOURCES

- H. A. Daynes: "Gas Analysis by Thermal Measurements," 1933.  
 H. Louis: "Mineral Dressing," 1908.  
 E. G. Richardson: "Applications of Photoelectric Cells to Mining" (Trans. Inst. Min. Eng., **88**, 265, 1934).  
 W. M. Thornton: "Miners' Gas-measuring Lamp" (Trans. Inst. Min. Eng., **85**, 335, 1933).  
 R. C. Walker and T. M. C. Lance: "Applications of Photoelectric Cells," 1933.  
 J. T. Whetton: "Geophysical Methods of Prospecting" (Armstrong Coll. Min. J., **8**, 91, 1933).  
 E. Witte: "Determining Non-combustible Dust in Samples" (Trans. Inst. Min. Eng., **82**, 20, 1932).

### JOURNALS

Trans. Inst. Min. Eng.; Colliery Guardian.

## CHAPTER X

# PHYSICS IN FINE ART AND ARCHÆOLOGY

THE arts proper have long been a domain into which the scientist dared not trespass, but in the last few years a revolution has come about in artistic circles and the place of scientific research in the technics of art has been recognised by the setting up of physical laboratories annexed to famous museums and art collections such as the National Gallery in London and the Metropolitan Art Museum in New York. The artist more than any other person is inclined to regard the works of physics with suspicion as being of the essence of materialism. If anything, he bears more readily with the chemist, who, he has to admit, is useful in providing new colours and inventing new media such as 'plastics.'

Painting does not lie merely in the choice and apt use of pigments, but the technician must supply the painter with paints that behave properly and leave the artist to express himself in their use; otherwise the latter is placed in the position of a pianist at a concert expected to tune the strings or perform other 'running repairs' during the execution of a solo. The flow and durability of paints is a subject which is a matter for the physicist, though it is often left to his consulting chemist by the colour manufacturer. Though there is as yet no journal devoted solely to paint physics, the Association of Oil and Colour Chemists encourage discussion of these matters in their meetings and lectures.

Paint is a colloidal suspension of a solid (the 'pigment' or 'body') in a liquid (the 'vehicle' or 'medium'). Paints are sometimes classified according to the relative concentration of solid and liquid phase, though with no clear-cut division, into granular (quasi-solid), vehicular (intermediate), and pelli-

cular (nearly all liquid). The third class includes the glazes and varnishes.

Natural earth colours, oxides, ochres, and umbers are dried in a kiln and then pulverised. Other coloured pigments are prepared artificially by chemical action in solution, followed by precipitation. The grinding usually takes place in the oil which is to form the vehicle, but sometimes it is found better to do it in water and then displace the water with oil to which the pigment cleaves while throwing out the former liquid.

Granularity can be measured as described in Chapter V. The zinc whites have particles up to five microns in diameter, but this is exceptional and the majority of pigments lie below two microns. For some purposes it is important to be able to obtain information about the shape as well as the average size of these submicroscopic particles. This is done by means of the electron microscope. The delineation of objects under illumination fails when the size of the object is comparable with the wave-length of the light used. When these are comparable the clear-cut image is replaced by a blurred diffraction pattern, for the common statement that light travels in straight lines is only an apparent truth, valid when the obstacle placed in a beam of light is large compared to the wave-length. With a beam of electrons we have an associated wave-length comparable in length with X-rays and much smaller than the pigment particles which it is desired to photograph. The electrons are produced from a heated filament in an evacuated vessel. They must then be concentrated as a beam upon the powder grains and then refocused upon the sensitive plate which is to record an enlarged picture of the object. The optical arrangement required is just like that for throwing an image of a slide on a screen in the projection lantern, except that there are no actual lenses. In place of glass lenses, magnetic fields set up by coils at suitable positions at the sides of the 'microscope' concentrate and deflect the beam as required to produce a sharp enlarged image. The device is also employed in the detailed examination of fine surfaces.

It is now generally conceded that the purpose of the grind-

ing process is not merely to sever lumps in the material but to break down the small aggregates of pigment particles and to secure the dispersion of individuals into the vehicle. By increasing the total surface the solid gets a greater chance of being properly wetted—using this term in a general sense—by the liquid medium, and this again prevents them settling down as a coagulated mass on the floor of the containing vessel. Good dispersion results, then, from general wetting of the solid particles, and this is found to promote good brushing properties and a glossy film. On the other hand, it is suspected that too high a degree of dispersion makes the paint deteriorate quickly. The paint manufacturer therefore compromises in this particular.

Yet if the pigment does settle, as long as the granules are properly wetted by the vehicle there subsists a sufficient surface tension to make them retain a surface envelope even when they are massed together at the bottom. A little stirring will redisperse such a paint; whereas in a cheap paint it will be found that prodigious efforts are needed to uncake the coagulated mass which is found at the bottom of a clear liquid after a few weeks' disuse. Such cementing together indicates that the wetting that they had in suspension was at most a temporary one. While this accurately describes the known state of affairs as regards the physical side of paint mixing, it is not easy to find a vehicle for each and every pigment which will guarantee permanent wetting, hence the exasperation with which many an amateur house-painter has discarded a pot of colour which he has allowed to stand for some time in the hope—based on the price he paid for it—that it would still be of use for subsequent work. The ability of a suspension to change its properties on stirring or agitation is known as 'thixotropy,' and involves a change from sol to gel and back again purely under the mechanical action and independent of temperature changes (cf. p. 130). When the particles with their liquid envelopes come together at the bottom of the vessel or on the 'ground' of the picture or other article to which the paint is applied, they form a jelly which is disturbed and reverts to a sol when the

pot is stirred or the paint film brushed over anew. When paint is stirred this process can be seen in the change in viscosity, which at once falls and rises again on standing. Structurally it is accompanied by the formation (on settling) and redispersal (on brushing) of loosely bound aggregates. It has also been found, by studies in the electron microscope, that thixotropic materials usually possess an oriented granularity—needle-like, cruciform, or prismatic shapes—whose disposition relative to the direction of shear of the brush is upset as soon as they are left alone. If thixotropy is accompanied by marked plasticity, the sol-gel or gel-sol transformations may, however, be quite slow.

The property known as 'flow' is physically the ability of a paint to form a smooth surface film on the ground to which it is applied and therefore involves both the surface tension and the viscosity of the paint. Plastic and highly thixotropic paints leave an uneven film when brushed out because of their ability to withstand small stresses, even if only temporary ones subsisting until the vehicle has dried. On the other hand, a smooth finish is at once obtained with a more fluid paint, but it may start to run and blob before it has had a chance to dry. It is the power to form aggregates—to flocculate—which lies at the root of a coarse painted surface, for it confers plastic properties which delay flow. With oil paints in which the vehicle does not evaporate at all or but slowly, a certain amount of plasticity is desirable, otherwise the paint would run when applied by the artist to a vertical canvas. The pigment then clots, leaving films of oil which may, under the action of their surface tension, collect into channels. The drainage of the medium into these leaves an intervening plaster-like solid which soon breaks down like a heavy clay soil denuded of water.

The relative concentration of pigment is lower in the gloss paints than in oil paints, so that flocculation is less rarely met in the former and their smaller rigidity enables them to flow more readily. By the addition of suitable chemicals an oil enamel may be made so little plastic that it is impossible to apply it to a vertical plane without sags and runs. The

sagging can be stopped to a certain extent by the addition of volatile 'thinners' which allow the artist to level out brush marks before the decrease of fluidity as they evaporate makes the enamel set in an uneven finish. Volatility, however, is a function of atmospheric conditions so that the expected process may be spoiled by too slow or too rapid convection. In order to increase the levelling properties of gloss finishes the manufacturer allows a coarse finished pigment to mature in the form of a paste and remills and disperses it before dispatch to the customer. The maturing period increases the degree of dispersion so that the levelling powers of the medium can overcome the rigidity imparted by flocculation of the pigment.

The estimation of colour is another field in which the physicist can help the artist. Ultimately, of course, appeal must be made to the eye. A list of recognised tints has been drawn up and names and numbers given to them. The function of the physicist is then to devise an apparatus which will match any artist's colour to one of the standard tints without, if possible, the intervention of the eye as matching agent. Colours may be made up either by mixing different quantities of three arbitrarily chosen hues in the red, blue, and yellow respectively, or by picking out a small region of the complete spectrum of white light.

The former is the older system and is the basis of the Lovibond tintometer, an instrument much used by industry for the measurement and recording of colour. It suffers from the disadvantages that the standard red, blue, and yellow are standard for the instrument only and not universals, though the Lovibond coloured glasses in different instruments agree among themselves very well and do not change with age. The comparison is made by eye between a suitable combination of the standard glasses in various thicknesses and the light diffused by the paint. The glasses are backed by a white block of magnesium carbonate and the combination varied until a match is obtained. If the comparison colour is a transparency such as stained glass this is backed by another white block.

An international commission on illumination has decided

upon three standard sources of illumination. One of these (Standard Illuminant B) corresponds to average daylight in England. The complete spectrum of the source is divided up into narrow strips to each of which is assigned three numbers representing the proportion of standard red, blue, and yellow in the spectral colour of the strip. Any tint can then be represented in terms of these three parameters, but since white light also contains these same primary colours, the given tint can likewise be represented as so much of any pair of these, for example red and yellow, plus a certain amount of white light.

When equal values of the three slides are superposed and viewed against a white background they appear as a neutral grey. Increasing the density of each colour by adding further slides cuts down the brightness of the transmitted light.

In Schofield's modification of the tintometer the brightness control is separated from the colour matching and only two of the series of tinted glasses are needed to match the quality of the specimen. An obturator vane *V* pivoted between the white source (in the form of a glass screen *W* illuminated by daylight reflected from the mirror *M*), and the two samples  $A_1$  and  $A_2$  to be compared allows the relative brightness on either side to be varied as the vane is rotated (Fig. 46). In

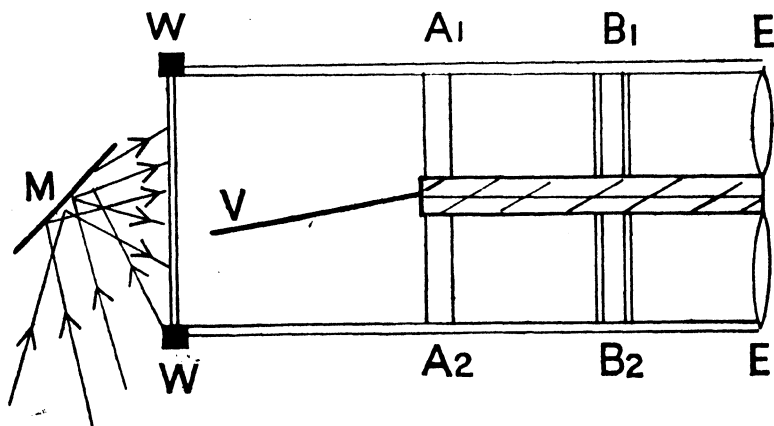

FIG. 46.—SCHEMATIC DIAGRAM OF LOVIBOND-SCHOFIELD TINTOMETER

ordinary working  $A_1$  would be a standard white backed by the coloured slides  $B_1$ , while  $A_2$  would be the coloured specimen backed by an equal thickness of colourless glass,  $B_2$ . E is the eyepiece through which the comparison is made. In the figure we illustrate only the *principle* of the instrument. In practice a reflecting arrangement instead of a transmitting one is employed, but would be more difficult to follow without actually seeing the instrument.

It will be noted that the arbiter in the matching test on the Lovibond-Schofield tintometer is still the human eye, and it is assumed that the person using the apparatus has normal vision. It is likely that in a few years' time matching will be done by a photo-electric cell and be entirely objective. The only obstacle at present is in getting exact correspondence between photo-electric cells so that a number of instruments can be sent out all having like characteristics and a sensitivity approximating to that of the normal eye. Research in this direction is progressing.

Much has been done in the identification of paints on old masters by the use of ultra-violet and infra-red radiations. When it is not desirable to pick off a sample of the paint for chemical analysis these radiations form the only sure tool for identifying the paint material which was used. Ultra-violet light is the easier to use since it may be produced by a mercury vapour lamp with a filter to cut out the visible rays. Most varnishes have a fluorescent spectrum of their own, so that by observing the visible fluorescence under the mercury lamp it is possible to discover where a painting has been retouched or when chemicals have been used in restoration, save in the unlikely case of the restorer having used the same materials as the original artist. Sometimes erasures and alterations on documents, or palimpsests—the use of an old canvas for a new picture after the old picture has been painted over—can be detected by this means. A case is on record in which insurance stamps had been removed from a card by another employé and cleverly imitated by hand; but the difference between the real and the faked stamps was obvious beneath the mercury lamp.

Although inks do not show much variety among themselves in this respect, the nature and age of paper can often be deduced from its fluorescence. Old paper does not contain sulphides, which are a common source of fluorescence in recent documents, while paper from rag shows a stronger spectrum than one of wood pulp. Watermarks show up very nicely. This is the basis of the modern system of secret laundry marks, which become visible to the sorting hand under ultra-violet light. Seals, adhesives, precious stones, etc., likewise show differing fluorescence, but it must be realised that the use of this tool in the examination of objets d'art is limited by the expert's knowledge of the fluorescent spectrum of the substance in question and his capacity to distinguish it from others of a similar type.

The artist has not lost sight of the possibilities of fluorescent light as a new milieu and sometimes paints pictures in fluorescent oils in the hope that they will be hung in a gallery fitted with mercury lighting!

Infra-red rays are more promising in the study of the structure of a painting since they can penetrate beneath the surface covering of varnish and dirt; but one cannot merely look at the picture under these rays; photography must be resorted to. Old books, censored by the Inquisition, have yielded up their secrets under infra-red photography, where the ink used by the censor happened to be more transparent to the radiation than the ink of the original manuscript. In the same way erasures in a document may be pierced through, but the process will not work when the glossing material is equally or more opaque than the original.

In spite of the success which has attended the use of these radiations it is in the microscopic examination of pictures, whether by visible light or by X-rays, that most advance has been made in the study of old pictures, both from the point of view of their identification and of historical studies in bygone painting technique, or again to scrutinise their present state and decide on the best means and time for their restoration. The picture is made up of a series of layers whose 'profile' working upwards consists of, firstly, the support (wood, canvas

or stone); secondly, the ground or priming, the first coat as it were of neutral colour; thirdly, the paint film of the actual picture; and fourthly, the protecting film (varnish). As in a soil profile, these four horizons may each be compound and may interpenetrate more or less, so that, for instance, the varnish becomes mixed up with the paint film. The microscope can show up not only the grain of the support (if of wood or stone) or the warp and weft (if of canvas), but also the degree of dispersion of the pigment granules. This allows one to classify, in the manner we have indicated, and to a certain extent to date the paint colours, since aforetime there were not the machines for inducing a fine degree of dispersion which are available to-day. If a little of the paint can be scraped off near the frame, spectrographic analysis may succeed in dating a paint. It can, for instance, differentiate the modern cobalt blues from the classical pigments. Identification of the vehicle is more difficult by this means.

The microscope tells the expert also the nature of the mechanical link between the film of paint and the ground and enables him to detect discontinuities in the film. A deal of such ageing imperfections arise from excessive relative motion of the strata when the picture has been rolled up or its support damaged. Heat is another source of trouble. Even the nature of the picture itself, whereby a heavily pigmented layer adjoins or underlies a lightly pigmented glaze, may cause flaking due to their differing expansibilities and plasticities. 'Crackle,' which often manifests itself as a series of miniature fissures and volcanoes, is ascribed to warping of the support or over hasty application of the varnish. It has even helped to settle the authenticity of a work.

X-rays, too, are much used in the scientific study of pictures. The results depend very much on voltage and current conditions, which should therefore be stated. Information on the 'whites' is so obtained, the relative densities of the lead salts employed being known from the extent to which they are pervious to X-rays. So it can be surmised whether the whites arise from the ground on which the paint film is applied, from the latter

only, or from both in part. Though lead and mercury pigments absorb the rays fairly well, they are not stopped by other pigments, so that little detail will remain in the X-radiograph if too high a voltage is employed, and the penetrating power so boosted up. As latterly pigments containing carbon compounds (benzene derivatives) have become the rule, whereas they were rare formerly, some inkling of the date of the picture can be derived from the relative clarity of the radiograph in different spots on the picture.

Great strides forward have been made in microphotography, a young science destined to be of great service to the museum curator and librarian. The grain of a photographic emulsion is now so fine that copies of documents may be made page by page on sub-standard cinematograph film (16 mm. wide) and subsequently projected page by page at full scale or larger when required for consultation by a reader in a distant institution to which the library or museum possessing the original does not feel justified in sending it on loan.

Physical studies of paintings by microphotography and radiations fall into two categories. On the one hand it is desirable to make a periodic examination of the structure of the paint and fabric to see how far deterioration is taking place in 'old masters' under atmospheric conditions, heat, light, and humidity. On the other, more stringent examinations may be necessary when it is a question of the detection of fakes and retouchings. In the latter pursuit the physicist finds himself in the invidious position of having to define 'old mastership' in terms of factors that can be tested. Lacking a norm for comparison purposes, he is forced to collect masses of physical data about old and recent pictures in the hope of, say, extracting from them a set peculiar to a Titian and a different set for a Rembrandt; a thing practically impossible to do, for the reason that the technique of an artist defies minute scientific analysis. Again, the laying bare of a palimpsest, to which we have already referred, presupposes that the types of paint and method of application adopted by the successive painters shall differ sufficiently to make them respond unequally to whatever





FIG. 47.—ITALIAN PAINTING UNDER ORDINARY LIGHT



FIG. 48.—ITALIAN PAINTING UNDER X-RAYS (*Rautins*)

PLATE IV

radiation, ultra-violet, infra-red or X which the investigator brings to bear. Fakes in which painting in the style of a well-known master is built up round a genuine old, but worthless, picture are probably the easiest to unmask. In one case the difference in the size of warp and weft threads on an X-ray photograph as compared with the same ones seen on the back of the canvas in visible light showed that two canvases had been stuck together, of which the under one proved to have been stolen from a wood panel.

Figs. 47 and 48, Plate IV, are examples of an Italian painting which Mr. Rawlins at the National Gallery proved to be the work of two artists. The X-ray photograph shows that the earlier artist painted another head at a different inclination. The eyes of the later head are clearly visible in the X-ray photograph.

The art of decorative moulding has been revolutionised in the last few years by the discovery of plastic resins which harden under the action of heat. In wet moulding with materials such as plaster and clay, the material must be sufficiently stable to withstand the force of gravity for at least as long as is necessary to drive off the moisture in a steam oven. This presupposes that the substance cast is in a quasi-solid state, and this means that it is not easy to fit it nicely to a mould of an exacting type, having many little interstices and excrescences. Again, in casting metals the casting must cool in the mould and the contraction which then occurs makes the metal block when removed from the mould only an approximation to the shape required, to which it must be trained by subsequent cold working with tools. The ideal material for modelling purposes is one which can be poured into the mould when cold in a fluid state and then solidified and toughened by heat so that the slight expansion which supervenes is enough to make it fit closely to the mould, but not enough to break it. Such substances now exist and are known to the trade as 'plastics.' The best known and the first to be commonly used is 'bakelite,' named after its inventor, Dr. Baekeland. All are types of synthetic resin of complex chemical form (based on

phenol) and usually incorporate a 'filler' in the form of fine sawdust, which adds strength to the final casting. Before the filler was introduced a certain amount of shrinkage took place in the mould. The wooden core eliminates this and so makes the casting take better to the mould, to which it accommodates itself with an accuracy equal to that of shellac compounds, but in the upshot makes a model far less brittle than shellac. The substance can be stored, prior to use for making castings, in sheets or in a powder paste, provided its temperature is not allowed to rise above  $120^{\circ}\text{C.}$ , at which temperature the hardening process sets in. The powder is put when required into the mould, previously warmed to  $150^{\circ}\text{C.}$ , and pressure applied to squeeze it and make it adapt itself to the shape; this it will do since the first application of heat softens it and makes it flow. The final pressure will amount to several tons to the square inch, held for several minutes during which the chemical action which accompanies the toughening process ensues. The component parts of the mould are then drawn apart to disclose the finished model.

The tests which are made on plastics correspond closely to those on clays (in the softened form) and timber (in the final hardened form). For instance, the flow properties of the raw material must be investigated before it is put into the press. In particular, one wants to know the temperature at which it will become sufficiently fluid to take up a shape. For such a test it is placed in the form of a powder in a small press provided with an outlet and heated up until, under the applied pressure, it extrudes from the hole, the pressure being meanwhile maintained at such a value that the stuff flows out with a constant mean velocity, say, of one foot per minute. As the temperature is further raised and the material hardens, the resistance rises rapidly and more pressure must be applied to maintain the extrusion at the former rate (cf. Fig. 49). From pressure: rate of flow curves of this type at various temperatures, the toughening process can be followed step by step. Of course, the testing of fluidity in such an appliance is not very precise even under ideal conditions, but it is favoured because

it imitates rather well the actual stress and strain which the material will suffer in the mould. In fact, the test is not so satisfactory, as a difference of temperature may be set up between the inside and the outside of the press whereby plastic

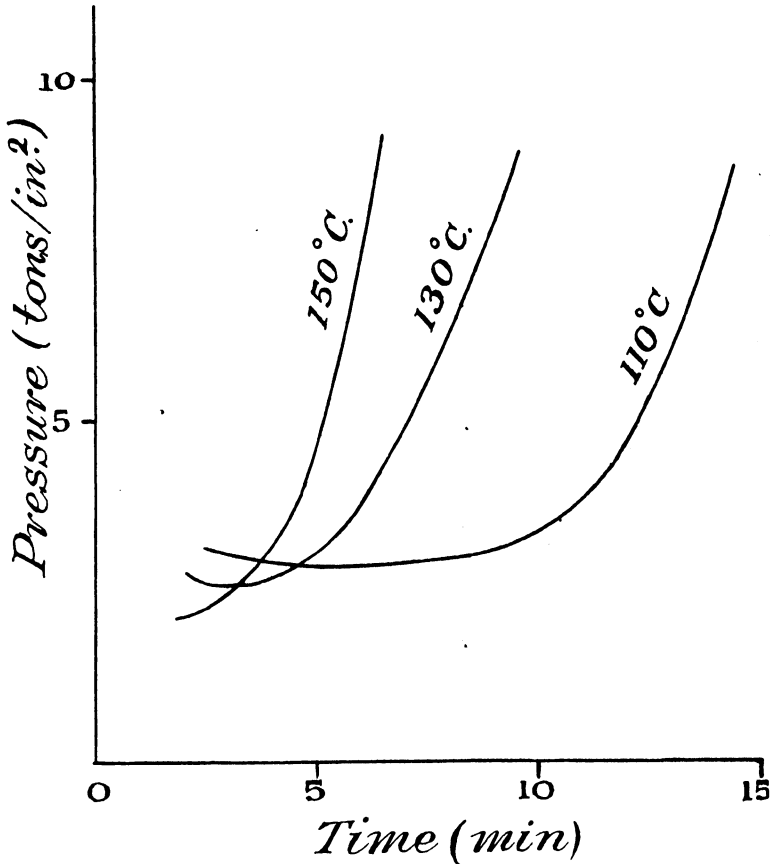

FIG. 49.—PRESSURE REQUIRED TO EXTRUDE PLASTIC AT CONSTANT RATE (after Bell)

sheaths of greater or less tenacity and viscosity than the core may be formed near the walls of the cylindrical body of the press, and again on emergence the cooling extruded billet may assume properties different from those it had inside the cylinder.

We shall not go into the strength tests on the resulting resin after its thermal treatment, since many of them copy those which we shall describe for timber in the next chapter, but there is one property peculiar to a synthetic resin which requires measuring, known as plastic yield. The test made is closely related to that of the crushing strength of timber (*q.v.*), but temperature intervenes. It is, in fact, that temperature at which a moulding will collapse under a given mechanical pressure, measured by the extent to which a loaded pin will penetrate a block from time to time while the temperature is slowly raised over the hardening range. Alternatively, a bar of the material may be supported at the ends and a weight hung in the middle to produce a measurable depression while the whole thing is kept in an oven at a precise temperature. Results of plastic yield with the same material and different modes of applying will not be consistent, for, like all semi-elastic materials, bakelite will behave differently with a given load according as this is placed on all at once or piecemeal and according as it takes the strain continually or intermittently with time to rest.

While the bakelite resins can stand a considerable amount of rough treatment, their natural propensity, in the absence of a filler, is towards brittleness and they do not exhibit flexibility. In this respect cellulose and its compounds are superior. A mixture of nitro-cellulose and camphor, suitably kneaded into a paste and rolled into sheets makes a substance useful for knife handles and pianoforte keys and in thinner sheets for moulding hollow articles like dolls. Celluloid has, of course, the disadvantage of inflammability, but acetate of cellulose has not, and can be moulded, although there is no satisfactory substitute for the camphor employed in celluloid. Its function is to endow the mass with plasticity for moulding and subsequently to be driven off by evaporation, which leaves the casting a little brittle.

A familiar use of cellulose acetate in these days is in a layer between two sheets of glass to form splinter-proof windows, though the early forms tended to take on a yellow tint with age.

The trade name, 'leucon,' is used for a substance like cellulose acetate but of more enduring transparency.

A whole new art, that of the cinematograph, has such substances as its milieu.

Yet a third type of plastic has its origin in milk. Casein plastics are made from the protein in milk after extracting the fat and can be fashioned into a number of transparent articles including lenses and horn substitutes such as buttons and knitting-needles. Its one fault is a tendency to absorb moisture.

Archæology is still regarded almost entirely from the standpoint of art, but there are signs that the archæologist of the future will require more than a knowledge of history and the ability to dig carefully—or to repair the results of indiscriminate digging. While it is true that the experienced sapper can tell from the ring of the spade in the ground whether there are large masses of hard material beneath, the echo-prospecting device which we described in Chapter IX ought to be of avail in directing digging operations. The chief obstacle in its adaptation to this subject lies in the short depth which separates the surface of the ground from the treasure trove and in the—usually—small superficial area presented by these objects; here we except such finds as the floors and pavements of Roman houses. As these were originally at ground level or at the height of a few steps above or below it, only the accumulated silt of centuries separates the investigator from his goal. As a matter of fact, the echo apparatus has been tested on paving-stones buried in modern times a few feet in soft earth and found to work with the following modifications (Fig. 50). The sending device consisted of a small pile driver S (like the pneumatic hammer used on the roads to pound the top soil back into shape after it has been disturbed for pipe laying). The one used in this instance delivered a blow on the ground several times a second. A geophone E (cf. p. 174) lies on the ground a few feet away and picks up first the disturbance that comes directly along the surface SE and, a little later, that reflected from the hidden block of stone via SCE. The electric potentials resulting in the geophone coils are passed to one

pair of plates of a cathode-ray oscillograph O, while the sweep circuit connected to the other pair carries the electron spot across the screen at constant velocity, one traverse of the screen for each blow on the ground. The two miniature seismic waves, direct and reflected, therefore appear on the screen as two sharp jags or peaks in the horizontal line traced

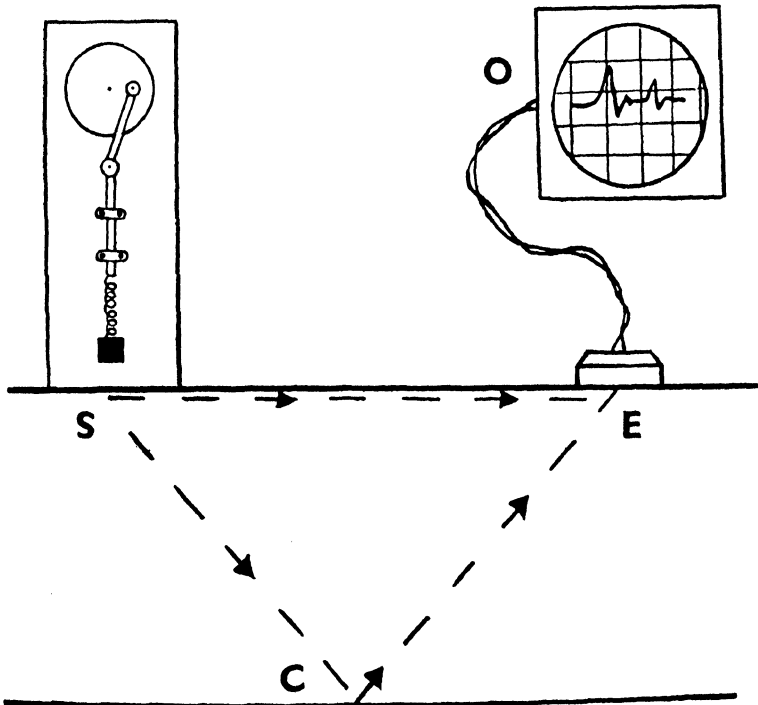

FIG. 50.—USE OF SEISMIC WAVES IN ARCHÆOLOGY

out by the electron beam under the influence of the sweep circuit. Since the latter has the same frequency as the pounding of the soil, these two jags always appear at the same two places on the screen (cf. fig.). From their relative positions on the screen the time taken for the direct and reflected waves can be calculated. The first position, plus the known distance between the source and the pick-up, gives us the velocity of the disturbance through the soil. Armed with

this datum and the time interval corresponding to the arrival of the second shock, the position of the buried stone can be calculated. We have assumed that the reflecting surface lies horizontally in the ground. If it does not, our method is not invalidated, but additional 'shots' must be made with alternative positions of source to find its inclination to ground level.

In the examination of earthworks, much has been achieved in recent years by photography, with or without filters, from aircraft. An aerial survey has now been completed of most of the districts known to have been worked by the ancient peoples of Britain, and not only has it been possible to descry the line of earthworks which could not have been traced at ground level but new camps and the 'lynchets' of ancient terrace cultivation have been established where their existence was formerly unsuspected.

An analysis of the soil on the lines previously described (p. 126) will sometimes add corroborative evidence, though scarcely conclusive on its own. In a case in which the author was concerned, excavations were being made at an earthwork fort near Birdoswald on the Roman Wall that stretches across northern England from Tyne to Solway. (This was in the region where the stone wall gives place to an earthen parapet.) To find whether the foundations of the fort were contemporaneous with the wall, after removing accumulated silt, samples of the earth from the latter were submitted to mechanical analysis and compared with those of the vallum or ditch from which the soil material for the wall had presumably been thrown up, and also with samples from the base of the fort. This last gave a different particle size distribution and was blacker in colour than the other two. This evidence alone is scarcely enough to settle that wall and fort were not built at the same time, as the material for the fort might have been brought up in carts from elsewhere while the parapet was building, but other clues derived from finds in the debris of the fort, which sustained this physical analysis, indicated that the fort was indeed of later date than the wall. It is rather striking that after nearly two thousand years, during most of which the land had

been under grass, soil from the rampart should still bear a physical similarity to soil in what was the bottom of the ditch from which it came. This leads to the hope that the methods of soil analysis may be more widely used in connection with archæology.

Although we have excluded the science of metallurgy from our syllabus, since it is usually regarded as a subject distinct from physics and rightly so, we cannot pass on without a mention of the application which metallurgical analysis has found in the study of the finds of the antiquary. When ancient metallic objects are found in the neighbourhood of camps and forts it is usual to submit a portion for expert examination of its micro-structure. It is perhaps too optimistic to say that one can deduce the date of the manufacture of the specimen from such information, but data are being accumulated which show some correlation between the technique employed in the casting and moulding and the approximate date of manufacture, when this is known from circumstantial evidence. It is known, for instance, that in England between the twentieth and the tenth centuries B.C. brass and bronze alloys were in use whose composition is the same as in certain modern alloys, and that when Roman alloys of tin and lead involving about five per cent. of the former were used, a secular change caused the crumbling of the vessel into powder; this is the so-called tin disease which was prevalent in modern times before it was counteracted by changing the proportion of tin. Microscopic examination of minute portions of the surface of primitive tools shows how far the ancients were able to carry out annealing by alternate heating and quenching to harden the tool edge.

#### SOURCES

- L. M. T. Bell: "Plastics," 1937.
- E. J. Bond: "Flow of Paints" (Trans. Oil & Colour Chem. Assoc., 20, 195, 1937).
- H. W. Melville: "Plastics in Industrial Physics" (Phys. Soc. Progress Rep., 5, 34, 1938).

- J. A. Radley and J. Grant: "Fluorescence Analysis in Ultra-Violet Light," 1935.
- F. I. G. Rawlins: "Chemical Physics of Paintings" (Science Progress, **34**, 263, and **33**, 483, 1939).
- E. G. Richardson: "Flow of Liquids and Liquid Suspensions" (Trans. Oil & Colour Chem. Assoc., **21**, 215, 1938).
- "Physics in Archæology" (Discovery, **21**, 68, 1940).
- P. D. Ritchie: "Science Problems in Fine Art" (Discovery, **16**, 258, 1935).
- R. K. Schofield: "Lovibond Tintometer with Rothamsted Device" (J. Sci. Inst., **16**, 74, 1939).

### JOURNALS

Trans. Oil & Colour Chemists Assoc.

## CHAPTER XI

# PHYSICS OF BUILDING MATERIALS

THE properties which the physicist tests in a substance to be incorporated in a building are first and foremost those which relate to its capability of being fashioned and its durability when in position in the finished structure. This does not, however, complete the knowledge required by the builder, since the inhabitants must be made secure against extremes of hot and cold and, if it is a town house, against noise.

Apart from natural materials such as dressed stone and timber, the artificial ones which are embodied in a building comprise those which are manufactured by some form of heat treatment like bricks and glass or those which after mixing set fast as the result of a chemical action, such as plasters and concrete. Since the problems which arise in the brick, tile and glass industries so closely follow those in the pottery trade, we shall not reiterate them but devote most of this chapter to the physical properties of wood and plaster, though what we shall have to say on the subjects of heat and sound insulation will apply to all building materials.

The naturally occurring woods are distinguished from each other—and selected for diverse uses—in respect of density, moisture content, and behaviour under stress. Wood is made up of cells, and there are in addition fibres or chains of cells which form the grain; save at places where the texture is interrupted by channels for the sap or resin or by knots where the points of insertion of the lateral branches occurred and have been glossed over in the subsequent increase of girth. The timber is not, however, all solid matter. Apart from water, a considerable fraction of the total volume is occupied by included air, or other gas. The greater or smaller pore

space in a cubic inch of wood accounts for the large variation in apparent density between different woods. Whereas the specific gravity of the solid walls of the structure is always close to 1.5, the weight of a foot cube varies from 3 lb. to 83 lb., whereas if the whole material had a specific gravity of 1.5, such a cube would weigh 94 lb. There is also some variation in the wood of an individual tree, the heaviest usually being near the middle of the base, from which point it decreases in density both upwards and toward the circumference.

Density is a practical criterion of strength, since both these factors run hand in hand with cell wall thickness, but it is not thought sufficient in the laboratory to measure density when strength is aimed at. Rather are test pieces of small bulk so selected as to be free from irregularity or blemish and subjected to a number of types of force, corresponding to the ones they may suffer in working, and their behaviour recorded on special machines.

These tests are concerned with the different moduli of elasticity. To every constant stress there corresponds a strain; a change of shape or of size. At first, the wood suffers a gradual change in proportion to the applied stress, but when a critical value of the stress has been exceeded the cell walls give suddenly and break in one direction or another where the resistance is least (save in the case of equal compression in all directions, and this is not a practicable test).

When making trials perpendicular to the grain a direct pull or push can be given to one side of a block while the opposite side is held in a vice, and the change in dimension measured. This is in fact the test we have already described in its application to dough (p. 108), save that the actual stretch or compression is, of course, much smaller for a given load in the instance we are now concerned with. The pull is continually increased until the wood parts; the push is increased until the elastic limit is reached, that is, when the strain is no longer proportional to the stress. The value of the limiting stress is then calculated by dividing the load by the area of the bearing surface.

When the wood is compressed in a direction parallel to the grain it tends to buckle, and the amount of bending must be determined at the time that the load is applied. This is done by means of the apparatus shown in Fig. 51. The sides of the block are in contact with a series of mirrors, so that a ray of light from the telescope on the left falls upon an inclined mirror in contact with the right-hand side of the block, is there reflected

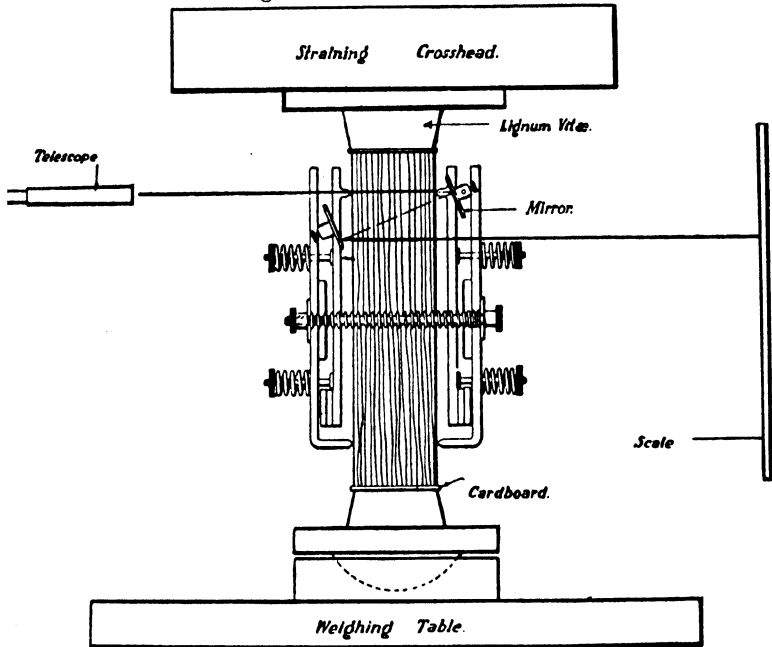

FIG. 51.—APPARATUS FOR MEASUREMENT OF COMPRESSION OF WOOD PARALLEL TO GRAIN (From "Forest Products Research Project 1: Mechanical and Physical Properties of Timbers—Tests of Small Clear Specimens." By permission of the Controller of H.M. Stationery Office)

across to an equally inclined mirror on the left-hand side of the block and thence away to the right of the apparatus to fall at a certain point on the scale. If the test piece buckles under the load, the two mirrors, while conserving their relative positions on the block, do not bear the same angle to the incident beam of light; consequently, the scale reading seen in the telescope changes. From the extent of this displacement the deviation of the grain of the test piece from the vertical may be estimated.

The load is applied with increments at regular intervals and the deformation measured until the breaking load is reached. This test is particularly necessary when the timber is to be used for props or spokes wherein a high resistance to compression along the grain is a *sine qua non*.

Other measurements made are of the shearing strength—the force required to shear off a projecting lip—and of the force required to bend the specimen by a specified amount when the ends are supported and a load applied to the centre. This latter test involves several forms of stress, not readily separated into precise physical types, but it is useful in assessing behaviour when used as a girder or bearing beam. When the beam breaks under such a test, the fracture is characteristic and can be used by the expert to classify the timber. A brittle wood shows a clean fracture often with two projecting spikes, one from each side of the cleavage. If it is fibrous and so more flexible, a large number of little spikes remain; the failure is not clean, in the sense that only one half may break away, the remainder holding together by intermeshed fibre fragments.

Strength is not the only property which a builder demands of his material; in many instances, tractability is equally important, since it has nearly always to be worked before being built in. To test this property, penetration experiments are carried out. In testing hardness, for example, the force needed to embed the hemispherical head of a rod of half an inch diameter to a depth equal to its radius is used as a basis of comparison. While this is the accepted criterion of hardness in the timber trade it is not truly a quantitative standard in respect of sawing, filing, and the like. There are, for example, certain tropical timbers which appear soft when submitted to the penetration test but impose great wear on cutting edges.

It should be added that these strength and hardness tests are usually made both when the wood is in the green and in the seasoned condition or, if necessary, at various stages during the seasoning process. The moisture content must be determined and its value at the time of the test stated or else, by simple calculation, the strength corrected to a standard value

of the humidity may be quoted. The dried wood is usually found to be more brittle than the same wood when green, the sap conferring flexibility.

We have already instanced the importance of the relative space occupied by the cells in the bulk as indicative of strength and density. It will appear in what follows that the same factor decides the acoustic and thermal properties to a large extent. The 'cell space ratio,' in the form of the percentage of solid to total bulk, can be derived from measurements with a microscope or with a photo-electric cell. The former is a tedious process as it involves the traversing of a thin slice cut from the specimen with a powerful microscope and estimating the fraction of the diameter occupied by fibres; and this must be done on several traverses to get a reliable result. In the photo-electric method as developed by Barkas, the section is first stained in methylene blue and then placed in the path of a beam of light from a sodium lamp falling on a vacuum photo-electric cell. The reading on a galvanometer to which the latter is connected is then a measure of the light which has passed through the stain in the portion not occupied by the opaque fibres. A subsequent reading is taken of the amount of light passing through a clear slide of equal area and stained to an equal density by the blue. From these two readings the cell space ratio is directly derived.

The moisture relationships of wood are very similar to those of soil, except in degree. Since water cannot penetrate the cells so readily as it can the pores between soil crumbs and is less easily removed by drought, a loop such as that of Fig. 32, p. 137, for wetting and drying wood will be narrower and have a more restricted scale of water content for a given change of vapour pressure. The point corresponding to the equilibrium condition in the wood when all the free water is removed from the cavities and only the hygroscopic moisture adsorbed by the cells remains is called the 'fibre saturation point.' It has been shown that below this value, which corresponds to a moisture content of about fifteen per cent., the curve of wetting coincides with that of drying, but above this value—in the region of capillary

sorption—the curves are distinct and enclose a loop. To make Fig. 32 serve for wood, we must give the loop a tail by running the two sides together from fifteen per cent. moisture down to absolute dryness. Actually the 'fibre saturation point' is a theoretical state only, since it is impossible to remove all the cavity water without disturbing some of that adsorbed in the fibre.

The shrinkage of a block of wood is a factor closely related to water content, and it has been shown that change of size in such a block may be used to indicate the less readily measured moisture content, at least to the degree of accuracy which will satisfy the builder. There is a considerable difference in the amount of shrinkage and swelling shown by woods of various species, yes even in a single piece of timber, according as the test piece is cut with or across the grain. As in a textile, the latter is always the greater, because the fibres move closer together or farther apart as the quantity of water introduced between them changes, whereas the length of the fibrils is scarcely affected. As gradients of humidity in the ground cause water to move from place to place, so the drying of the exposed surfaces of timber while being seasoned causes movement of moisture outwards until the gradient disappears on the assumption of new equilibrium conditions. The change is, however, very slow and may take months to complete, during which time shrinkage continues. In the laboratory, experiments on wood: water relationships are unnecessarily complicated by such gradients, and it is desirable to eliminate them. This can be done by cutting specimens very thin in the direction of the grain so that the internal cell structure is laid bare. Curves of shrinking and swelling with changing water content can then be followed up and show the same general form as the vapour pressure : water content curves. As at low vapour pressures there is no cycle, i.e. the shrinking and swelling curves coincide, it is believed that when the specimen is nearly dry, the water is held entirely by molecular forces as opposed to surface tension forces.

We have already stated in describing the moisture relation-

ships that woods vary greatly in the hygroscopic property. Treatment of the wood by high temperature and impregnation with certain oils or coating with shellac will reduce this tendency to imbibe water but cannot prevent it entirely. What is perhaps more important than trying to stop the wood taking up or giving out moisture is to acclimatise the timber before it is put into a building by exposing it for long periods to the average humidity that it is likely to encounter on the site. While this acclimatisation is easy to ensure in small pieces, large and thick logs are difficult to season other than superficially. The drying of green wood in a kiln or wind tunnel has the object of hastening the desiccation of the sap, but the process must not be carried to extremes. When wood is put into a new building, the humidity indoors is likely to be around twenty per cent. As the plaster in the house dries, the humidity gradually approaches a permanent value which in temperate regions will average ten per cent. The timber work must be adapted to the equilibrium humidity and should not be fixed in position until the plaster work has been dried, whether naturally or artificially accelerated; though this is a counsel of perfection in these hurried times.

To obtain points on the drying and wetting loop, it is of course necessary, unless the shrinkage criterion is adopted, to measure the moisture contents corresponding to the prevailing atmospheric humidity as these grow or recede. One method is to weigh a small specimen cut straight from the log and to dry in a steam oven until all the moisture is driven out; cool and at once reweigh. This takes at least twenty-four hours. To verify that the sample is really 'oven dry,' the desiccation is continued for a further hour or two and the weighing repeated. Usually the two latter weights differ by less than one per cent., an error which does not signify in relation to the precision of this method. The evaporation method has the serious objection, apart from the expenditure of time, that the loss of weight is small and so liable to uncertainty in the region of low humidities where results are of the greatest significance. For this reason it is now being replaced by an electrical method.

This works on the principle that the electrical resistance of any porous or cellular material depends on the moisture content. All that is needed in an electrical moisture meter is a constant source of electromotive force and a galvanometer to measure the electric current that it can send through a defined length of the substance or else the potential required to drive a specified current through the same. The length is determined by a holder with which two needles are pressed into the specimen. The electrodes thus being set by gauge at a standard distance apart, the instrument may be calibrated to read moisture content directly if the test is made on timber of one species, but a correction will need applying when one passes from one species to another since the resistance of dry timber varies slightly from one kind to another. However, if the instrument is first adjusted to read 'zero moisture,' in terms of current or voltage as the case may be on an oven-dry sample, it will need but a slight correction on actual moisture contents, since up to the fibre saturation point the relation between electrical resistance and moisture is practically linear, which is fortunate, as this is the range which interests the stackyard. If the wood is resinous, there will be an error with the electrical meter; but this remark applies with greater force to the oven method of estimation. Other objections which have been made to the electrical meter are that it measures the average resistance between the probes and that the resistance recorded will depend on the depth to which the needles are pressed in; while a surface film of dew will vitiate the results. To a certain extent these objections are met by pushing the needles in up to the hilt and by placing them a small distance—an inch, say—apart. Indeed, it is claimed for one meter that it can actually measure a gradient of moisture in a log if a cut is made near one end and tests made from outside to the centre of the log across the exposed section, keeping the line of the needles in the holder parallel to the rim of the cross-section. With care in their use, moisture meters of this type are proving very useful in timber yards to examine the stage of drying of logs in the drying shed or to make a quick selection of logs below a

specified moisture content. For this purpose a lamp on the needle-holder may be made to light up whenever the moisture exceeds a pre-set value.

In all laboratory testing of wood from a pile desired to show a good statistical average result, it is, of course, vital to select a representative sample. This can only be done by repeating the tests with specimen logs chosen from different parts of the pile, avoiding extreme cases such as those on the outside of the pile or test pieces cut near the ends of the logs. Some timber merchants, indeed, discount the value of laboratory tests on small specimens clear of imperfections on the ground that the working material of the builder actually comprises large baulks not free from irregularities like knots. For this reason the tests in the machines we have described may be supplemented by corresponding tests on complete beams. Owing to the cost both of construction and operation of the apparatus, such work cannot be repeated often enough to arrive at figures for strength, flexibility, etc., for the logs in a specified stack which would be representative of anything but whole forests of wood. For this reason work on small specimens such as that carried out in the Forest Products Research Laboratory at Princes Risborough in England will remain of the greatest value to the industry as affording comparative data for the many home, empire, and foreign woods now on the market.

The urgency of the noise problem in towns has implemented the study of the acoustical properties of building materials in the past twenty years and has brought in its train the invention of new substances having special properties suited to the insulation of a building against external noise, or the reduction of reverberation in interiors. Before describing the special features of these materials we must give some detail of the methods employed to gauge the acoustic properties of a sample material in respect of its absorption and transmission coefficients.

For the sake of accuracy—though not of economy—large-scale measurements are to be preferred, but when it is merely a question of comparing the acoustic factors of two specimens, a

small-scale method suffices, in which the material is placed at one end of a pipe while a loud-speaker delivers sound into the other at constant pitch. Fig. 52 shows an apparatus of this class in which the pressure amplitude in the stationary wave system set up inside the pipe is recorded by a manometric capsule attached to the side. The capsule, shown to a larger scale, is closed by a rubber membrane to which is stuck a tiny mirror which reflects a beam of light from a lamp on to a

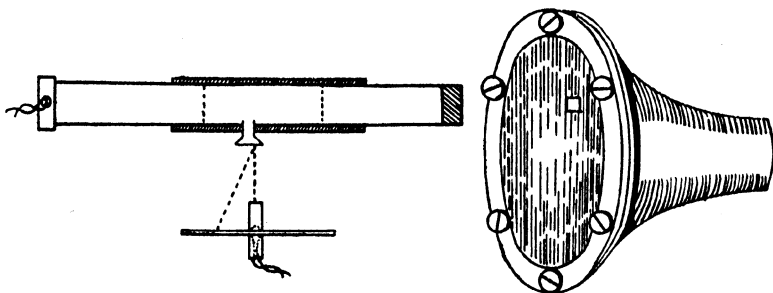

FIG. 52.—APPARATUS FOR MEASUREMENT OF SOUND ABSORPTION OF SMALL SPECIMENS (*Penman and Richardson*)

transparent scale. When the loud-speaker is silent the reflected beam of light is still, but the alternating pressure in the sound-wave causes it to oscillate and makes the spot appear, owing to persistence of vision, to be drawn out into a line whose length is proportional to the amplitude at the point in the pipe where the capsule is inserted. When the material closing the far end of the tube is hard and unyielding—a thick teak stopper may be used for this purpose—and the pitch of the source has been suitably adjusted, standing waves are set up in the pipe with nodes and antinodes each set half a wavelength apart. In true stationary waves the manometer records maxima of pressure amplitude at the nodes and no pressure change at the antinodes. With an imperfect reflector of sound like a porous tile in place of the hard stopper, the nodes show a reduced amplitude while the antinodes now exhibit some pressure movement. In fact, as the absorption of the sound at the end of the tube is made more and more by putting more pervious materials as stoppers, the identity of nodes and anti-

nodes is lost and replaced by uniformity of pressure amplitude along the pipe, such as we should expect if progressive waves passed along it without reflection at the far end. From a knowledge of the relative amplitudes at the pseudo nodes and antinodes when the imperfect reflector is in place, we can calculate what fraction of the sound of that frequency is being absorbed by the specimen. The absorption coefficient is expressed as the fraction of the incident sound energy which fails to be reflected.

As a basis for comparison, let us mention the extreme values for common materials. Whereas very hard wood, panels, marble, and the like have absorption coefficients less than 0.1 per cent., a wide open end with free access to the air is reckoned to be 100 per cent. absorbing.

Another method using small pieces of material, but requiring rather more space, allows one to determine both the amount of sound transmitted by a specimen as well as that reflected. It involves the delivery of a beam of sound from a directional source on to the specimen which is let into a massive wall like the hatch of a dumb waiter. A large parabolic cone collects the sound from the reflected beam (on the same side of the partition as the source) and concentrates it on to a microphone at the focus of the paraboloid. This registers the amplitude in the reflected beam. A similar collector and detector on the far side of the partition records the transmitted amplitude. To estimate the intensity of the original beam where it falls upon the baffle, the latter is taken away and the reading of the second detector, upon which the incident beam now directly bears, taken afresh. If, during this final measurement, the reflection detector registers anything other than zero energy, it is an indication that the sound is not being kept properly within the bounds set for it by the parabolic horns and that some diffraction is afoot and likely to upset the measurements. The absence of spreading is difficult to ensure unless the pitch of the source is high. It is therefore to high-pitched sounds that this—the Watson method—is best adapted. Once values of the incident, reflected, and transmitted sound have been got,

simple division of either of the latter pair by the first gives one respectively the reflection and transmission coefficients of the material.

Results obtained by either of these methods actually depend on the size of stopper (in the pipe) or baffle (in the double chamber). It is for this reason that results so obtained lack the precision of full-scale methods. It is not until the specimen is a yard or two wide that values that can be directly applied to considerable areas of the material without a 'finite area correction' are obtained. For this reason a number of laboratories have been built in which the whole of the walls of a full-sized room can be covered with the test material and the absorption coefficient measured by comparing the time which the sound takes to die away to nothing after the supply of energy to a standard source has been cut off. Such a reverberation room is often combined in the same building with another pair of rooms separated by a wall made of the same material through which transmission tests can be made.

Fig. 53, Plate V, shows a view of the reverberation chamber in the acoustic laboratory of Newall's Acoustic Co. at Washington, Durham. The building has four rooms: two for transmission measurements, one for absorption, and the fourth to contain the instruments and workers, since it is obviously undesirable to have people walking about the test rooms while measurements are being made. The walls above ground are composed of two layers of four-inch brickwork with an air space between, also subdivided to prevent any leakage of sound by any track from room to room other than through the experimental partition. The floors are of thick concrete on a layer of rubble three feet thick and the floors of neighbouring rooms are not contiguous. The ceilings are similarly thick and separated. Double doors are provided to the rooms and they have distinct frames, held together by interposed layers of insulation. When it is desired to simulate open-air conditions, the walls, ceilings, and floors of the rooms of such laboratories must be heavily loaded with absorbent material in order that no sound incident upon them may be returned to circulation. Layers of

rock wool, a silica by-product whose name is sufficiently indicative of its nature, are often used for this purpose, being held in position by wire netting of the type often seen on poultry farms. Duck-boards are provided along certain paths over the floor where the operators may have to walk to adjust the loud-speakers or microphones.

To measure the absorption afforded by a given substance it is fixed on frames which may be set with their backs to the wall of the reverberation chamber, in which both loud-speaker and microphone are set up. The former is then made to give out a pure tone of constant pitch or a 'warble tone.' This is a tone whose frequency fluctuates to and fro over precise limits at a slow rate of two or three periods per second. (The object of this device will appear shortly.) The source is suddenly cut off and the microphone connected in circuit with the voltmeter or other device which records its response. In a perfectly absorbent enclosure the sound will drop dead as the source is turned off, but otherwise the energy is banded about between the walls of the chamber until it falls to a pre-determined value. The stopping of the source may be made to set a chronometer in motion and the fall to this pre-set minimum to stop it, through the intermediary of the microphone and relays. We then have a record of the so-called time of reverberation of the room, and this is related in a simple manner to the volume and absorption afforded by the walls, that is, by a certain area of test material.

In a similar manner—though the working of the results is rather more complex—the transmission afforded by a known area of partition may be calculated if the loud-speaker is on one side of the partition and the microphone on the other, all other boundaries of the two chambers being as nearly as possible perfect absorbents.

The choice of the relative position of source and microphone in these experiments is not without bearing on the results, since the successive reflections between the boundaries, insofar as they are not perfect absorbers, will set up a pattern of diffraction maxima and minima in the room where the phases

of successive reflections conspire and conflict respectively. The result would not be affected if the pattern remained exactly stationary during the decay of sound, but this is not always the case. It is better to ensure that the pattern is thoroughly mixed up and transient rather than to attempt to eliminate it. The warble tone source does the mixing, since the pattern changes with every slight alteration of pitch, so that the nodes and antinodes of sound are constantly shifting about the room during the reverberation period. An alternative 'mixer' is a large vane slowly rotated in the middle of the room, which disturbs the stationary pattern due to a source of constant pitch by its varying angle of attack to sound-waves falling on it. Yet another device used in some laboratories consists in swinging the loud-speaker source of constant pitch slowly on a massive pendulum hung from the ceiling; this is equally effective in stirring up the acoustic ingredients of the energy mix.

While the science of building acoustics was still young, it was customary to use such materials for sound deadening as were to hand. Professor Clement Sabine, for instance, who was a pioneer in this science, used cushions and felt largely in this connection. Where felt would look unsightly he covered it with canvas on which painting was lightly applied to imitate tapestry. As it was the underfelt which was expected to do the real absorption work, care had to be exercised not to lay the paint on 'with a trowel' or the purpose of this palliative to excessive reverberation would have been vitiated. All good absorbents to sound are indeed porous or cellular in structure, and, in fact, their peculiar property arises from the damping which the sound-waves experience within the fabric. An ideal absorbent would, like the soil scientists' idealised soil, consist of a nest of fine tubes, not in the present instance all of the same length or diameter, for this would make them very selective as to pitch. Another type of pseudo absorption of the selective type does arise whenever a panel is so pinned to the wall that it, or the air cavity between it and the wall, is free to vibrate.

At the Bell Telephone Laboratories a room has been

designed to simulate an unlimited acoustic field. The walls of the room are covered all over with a number of layers of flannel and muslin separated by air spaces, varying from one-half to three inches, the floor having a grating supported free of the absorbent for the experimenters to walk on. Measurements of the absorption coefficient of the material both by tube methods and in the complete room showed this to average 97 per cent. above 150 vibrations/sec. Such rooms are, of course, of great interest in the measurements of audition.

Dr. Meyer has tested the frequency characteristics of this type of absorbent, more particularly in the case where the 'membrane' enclosing the air space is not porous. In such a case the natural damped vibrations of the air cell play a large part in its sound-absorbing qualities. The electrical analogue of this system is a resistance in series with an inductance and a condenser. The mass of the membrane fulfils the function of the inductance; the capacitance is that of the cavity; the stiffness of the membrane contributes to the resistance. The absorption is naturally very selective. Damping of the air cavity by introducing cotton-wool increases the absorption but makes the resonance peak sharper; this effect the author ascribes to coupling between membrane and air cell. He suggests that such a system, e.g. a paper membrane 5 cm. from a wall, with the interspace stuffed with cotton-wool, would be useful in technical acoustics when it is desired to absorb the lower frequencies at the expense of the higher.

Constable has also considered the effect of an absorbent lining in the case between *double* partitions both of which may 'drum.' His theoretical treatment is more general than Meyer's, embracing as it does the ricocheting of the sound energy within the cavity between the two panels, some being absorbed by the lining and another fraction being transmitted through the panels at each rebound. In conjunction with Aston, this author has also obtained vibration patterns of glass windows and brick walls. In the former case, the vibrations were excited by a nearby loud-speaker and the amplitude measured by search coils stuck on the glass within

the field of an electro-magnet. For the brick wall a brass rod attached to a moving coil loud-speaker was pressed against the wall. The amplitude contours fall into patterns which have a rather remote resemblance to Chladni sand figures.

But to return to actual acoustic materials; the disadvantage of everyday absorbents like felt is that they have neither durability nor appearance, and these defects make the builder and architect loath to use them. They are indeed not perfect from the purely scientific aspect, their acoustic properties often varying considerably with pitch. Usually the absorption coefficient rises to a maximum and then falls as the pitch of the source runs up the musical scale. The effect is complicated by the trend of the sensitivity of the ear with pitch. The ear is most sensitive in the middle of the scale and consequently parallels in this sense the behaviour of such a material as that which we are discussing. A substance which is perforated possesses another defect; its absorbent characteristics depend on the angle at which the sound impinges on it. Obviously, if the sound hits it square on, it will penetrate the crannies and suffer considerable attenuation before it emerges again; whereas an obliquely incident beam would be in great part reflected straightaway at the front surface and not suffer the ministrations of the dissipating crevices. In spite of this, useful acoustic materials have been fashioned from pulp boards, perforated by drilling patterns of holes about three or four to the square inch. The honeycomb so formed is usually backed by porous plaster or asbestos wool to give the energy a second chance of being dissipated before it re-emerges. The absorption of porous sheets can often be increased by mounting them at a short distance, perhaps one centimetre, from the brick or other hard surface which comprises the main shell of the building, the interspace being either left bare or stuffed with a non-inflammable 'wool.' This is particularly desirable with thin materials. A sheet of canvas mounted at an inch or so from a hard wall has been found to improve the acoustics of the room in which it was placed, without the

intervention of special materials. The difficulty is to render such a system tamper-proof and permanent.

As natural wood panels and ordinary plaster are highly reflecting to sound, a number of substitutes have been patented. We have already mentioned panels made of compressed pulp which are at least twice as efficient as hard wood. Acoustic plasters having a certain amount of porosity can now be made

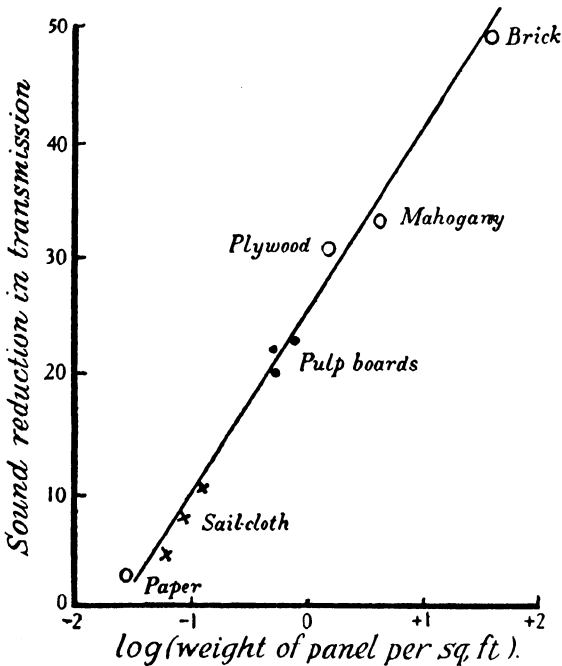

FIG. 54.—ABSORPTION AND WEIGHT FACTOR (Davis)

by incorporating chemical reagents in the mix which will produce bubbles of gas during the manufacture and so riddle the mass with holes which will remain after it has set, like baking-powder mixed with dough to make it rise. Some of these can absorb an average over the whole gamut of 70 per cent. of the incident sound.

As far as one can enumerate any general principles by which the acoustical behaviour of a specimen can be predicted

without recourse to a laboratory, one can say that the two factors to look for are porosity and density. We have already discussed the intention of the former in respect of *reflection* of sound. The latter factor is the most important single criterion to determine the behaviour of the material in *transmitting* sound. Fig. 54 (after the measurements of Dr. A. H. Davis) shows how the weight per square foot of different materials built as partitions between two chambers influenced the amount of sound transmitted. The two properties plotted—weight and transmission coefficient—are directly proportional. Thickness, *per se*, is not so proportional. Like all cases of absorbing energy, the first inch is more effective than the second; the thickness goes with the logarithm of the decrement of energy and is not directly proportional to the reduction of intensity itself.

Before leaving this subject we note an interesting application of microphone technique sponsored by the Forest Products Research Laboratory to the location of destructive larvæ in wood. Unless the experiment is done in a soundproof chamber, the sound-level of the environment is higher than that due to the insects. Even so the gain required in the amplifier is large enough to make background noise obstreperous. In one case, sounds between 1,000 and 5,000 cycles per second were sought for in a piece of wood suspected of harbouring the death-watch beetle. An intermittent rattle which could be brought to loud-speaker intensity was ascribed to the larvæ. Incidentally, the author mentions that in Germany a similar method was used to detect the larvæ of the house long-horn some years ago. It is hoped that it will be possible eventually to apply the method to the suspected timber of buildings, without the need to test piecemeal in a soundproof box.

Substances which are good acoustic insulators are usually good thermal insulators too, since the processes by which heat and sound are conducted through solid bodies are closely related. A cellular material is a bad conductor of heat, for the air enclosed in the little pockets is immobilised and air is an extremely bad conductor of heat as long as convection is inhibited. In wood, for example, the conduction of heat is

almost entirely attributed to the fibre, so that the conductivity along the grain is considerably greater than that across it, while in green wood the conductivity is more than that in hard wood in any direction because the sap carries the heat better than the air which occupies the intercellular space when the moisture has dried out. So good a heat insulator is dry wood that a thick wooden door is said to be a better protection against fire than a steel one—for safes and the like—owing to its lower conductivity. The wooden door fails only when the joints give way and allow the fire to pass through chinks in the joints or between the door and its jambs, so that the flames lick the door on both sides.

#### SOURCES

- W. W. Barkas: "Pore Space in Wood" (Proc. Phys. Soc., **46**, 544, 1934).  
 — "Wood Water Relationships" (Proc. Phys. Soc., **48**, 1 & 576, 1936; **49**, 237, 1937).  
 — "Lustre" (Proc. Phys. Soc., **51**, 274, 1939).  
 A. H. Davis: "Weight Factor and Absorption" (Phil. Mag., **15**, 309, 1933).  
 H. E. Desch: "Timber," 1938.  
 H. L. Penman and E. G. Richardson: "Absorption of Porous Materials" (J. Acoust. Soc. Amer., **4**, 322, 1933).  
 F. R. Watson: "Acoustics of Buildings," 1933.

#### JOURNALS

Reports of Building Research Station and Forest Products Research Station; Builder; J. Acoust. Soc. Amer.

## ARCHITECTURAL PHYSICS

A MAJOR change has come over the motive of architecture in the twentieth century. The architect of a hundred years ago looked to classical models for his inspiration and regarded as his proper function the translation of the art of æsthetics into a practical policy, as shown by the construction of buildings. In design, the appearance of an interior and its conformity to an established æsthetic ideal was of greater importance than such mundane matters as being able to see, hear, or breathe with comfort in the completed edifice, and if an audience were unable to do these things in comfort that was their misfortune and not the fault of the architect, who had given of his best in the medium in which he was entitled to find self-expression, as much as the painter with his palette and brushes. In illumination these exponents revered the candle and the lamp long after such things had ceased to be the stock-in-trade of the illumination engineer. The introduction of gas and electric lighting merely meant that globes, pipes, and cables must be cunningly disguised in chandeliers and lanterns. Electricity, at any rate, lent itself to such deceptions, and this retarded the true course of the development of fittings suited to the new illuminant. In a similar way, the traditionalist with his fondness for domes and alcoves held back the evolution of good acoustic design for interiors. Some of the blame for this must be laid at the door of the mediæval Church. In spite of the undoubted beauty of the Gothic style, it cannot be gainsaid that it does not lend itself to good conditions for seeing or hearing. This did not matter so much in an age when the service was known to the congregation by rote and they did not require to follow it in a book, being for the most part unable to read, but they were as much liable to miss words in

the sermon as present-day cathedral congregations owing to the excessive reverberation.

Nowadays this outlook has changed. Light and, to a less extent, sound are treated for their functional values. The people who use a building must be made comfortable first and foremost, both as to their bodies and mentally in respect of vision and hearing, and the design must be subservient to these primary desiderata. In fact, light may be introduced purely for its psychological effect, to soothe the dweller therein, and not for helping him to see what he is looking at. Sound does not yet seem to have reached this exalted level of service, unless, indeed, the orchestra in a restaurant fulfils this function.

It is from the point of view of getting adequate light and sound for the business in hand that we must consider this question, whether it is being participated in by all persons present or whether the majority are merely 'assisting,' in the French sense of the word. We have not space here to recapitulate the scientific facts regarding the senses of sight and hearing<sup>1</sup> but the reader must realise that the eye and the ear cannot be treated as pieces of physical apparatus. Their response to a given stimulus is not invariable—like that of a healthy galvanometer to an electric current of given magnitude—but depends on adjacent stimuli; adjacent both in respect of space or time. Thus the sensitivity of either organ depends on the background, whether daylight or starlight, whether city noise or country quiet. In addition, our visual acuity for objects directly looked at depends on the amount of glare or oblique illumination from other sources on to the eye. A very bright area projected on one part of the retina reduces one's sharpness of vision over the rest of the field of view. This is a point in favour of uniform or diffused illumination, in which conditions like those out-of-doors on a day when general light cloud covers the firmament are simulated within an interior; a now common régime for lighting except where intense

<sup>1</sup> For once the author breaks his promise and refers the reader to Chapter X of "Physical Science in Modern Life" for this information.

illumination over a smaller area is necessary, as in watch-repairing or fine needlework.

The emission of lamps is measured in candle-power. The standard candle is a candle of a certain size and made of stearine, whose steady flame is compared in brilliance with that of the source under test, by comparing the intensity of illumination which they can severally produce on a white surface at a certain distance. Since all radiation obeys the inverse square law of decline of intensity with distance, the illumination on the card, due to either source acting alone, falls off as the square of the distance as the source is moved away from the card. This fact may then be used to compare the brilliance of the two sources by finding corresponding distances from the white surface such that it appears equally brilliant when either lamp shines upon it. Using this as a measure of intensity of illumination, the unit is defined as the foot-candle, i.e. the intensity of illumination over a surface held at one foot square-on to the light from the standard candle. We can then express the light required by a worker on his bench or by a reader on this book in terms of so many foot-candles.

Formerly, the measurement of intensity of illumination outside the laboratory by a person not equipped with photometric apparatus was difficult to make, and was, in fact, impossible in a confined space except as a matter for guesswork. Now such measurements are facilitated by illumination meters incorporating the ubiquitous photo-electric cell. A portable unit consisting of two such cells in series connected by a coiled lead to a sensitive galvanometer in a case for measuring the photo-electric current is a handy instrument for this purpose. Light falling upon the cells causes the galvanometer needle to deflect over a dial, which can be calibrated directly in foot-candles. By placing the handle containing the photo-electric cells on the work-bench or office desk, the intensity of illumination afforded there can be at once read off, and increased if it falls below that which medical opinion has ordained as the minimum for that particular job. The instruments will measure down to the obscurity represented by one five-

hundredth of a foot-candle, which is the light afforded by a standard candle twenty-two feet away from the place of measurement.

In the laboratory, too, photometry—as the measurement of the luminosity of lamps 'is called—has been brought to a greater stage of precision with the advent of the photo-electric cell. In older photometers it was necessary to adjust the relative positions of lamp and standard candle on opposite sides of a white surface until they produced equality of brightness. This had to be repeated all round the lamp to allow for lack of symmetry in its illuminating power. In the new type of apparatus all the light sent out by the lamp in every direction is caught on the surface of a large white sphere several feet in diameter which completely shuts in the lamp, and of this a specified fraction is reflected upon the photo-electric cell which abuts upon one small patch of the sphere. By this means the power of lamps may be determined almost as fast as they can be put in and out of the integrating sphere, which opens and shuts like a monster Easter egg for this purpose.

Such an apparatus naturally sums up the whole of the light emitted from a lamp. For many purposes it is desirable to have data relating to the output in different directions from the lamp. Most incandescent lamps are symmetrical about a vertical axis, and in such a case the photometric observations may be confined to a single vertical plane through the centre of the lamp. The emission varies over this plane according to the disposition of the filament, arc, or mantle within the lamp. The results are plotted in the form of curves of constant luminosity along radial distances out from a central point in the axis of the lamp. Fig. 55 shows such polar curves for an unshaded electric lamp hung vertically and for the same lamp enclosed in a silvered glass reflector. The distance at which such a curve cuts any radial line gives the candle-power of the light emitted in that particular direction, taking the vertical line to represent the direction vertically down from the lamp. It will be observed how the reflector gives a spot-light effect, concen-

trating the light into regions immediately below the lamp and making it suitable for a reading-desk.

The quantity of light required for doing different jobs of work is a matter for the industrial psychologist rather than for the applied physicist. We may note that poor lighting has been definitely proved to be a source of fatigue and error among industrial workers. An extensive research in the printing industry has been conducted from this point of view by the Industrial Fatigue Research Board in England. They measured the output of compositors in terms of the number of

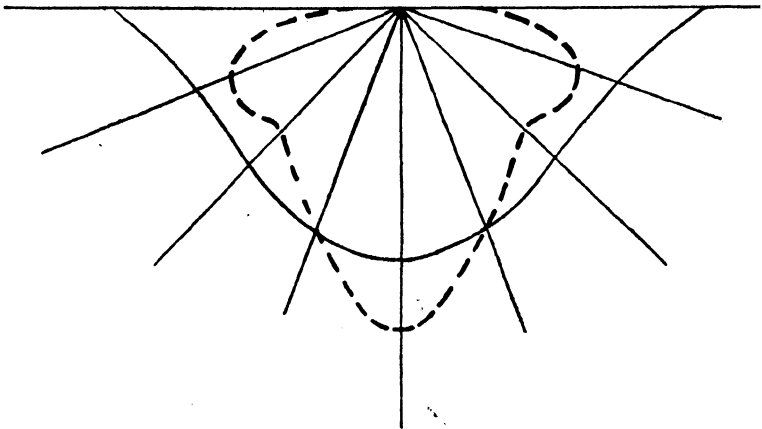

FIG. 55.—INTENSITY OF ILLUMINATION ROUND LAMP WITHOUT (FULL LINE) AND WITH (DOTTED LINE) SILVERED GLASS REFLECTOR

letters that could be set up per minute both in daylight and under artificial light producing intensities of illumination on the founts from 1 to 25 foot-candles. (Diffuse daylight is equivalent to about 300 foot-candles.) The results are shown as percentage of daylight output by the full curve on Fig. 56. The broken line shows how the number of errors—wrong type or inverted type—decreased as the illumination increased. For this particular work an intensity equal to daylight conditions is obviously unnecessary, for the full output is reached at a much lower value. Other work would show results of the same trend, but with a different value for ‘adequate illumination.’

Its value would be low, for example, for coal-getting—and is so, for economic reasons—but would be high for jewel-setting or watch-assembling.

In an ordinary room, or out-of-doors where flood-lighting is employed, the architect is concerned with getting as nearly as may be uniform illumination over a certain area. In flood-lighting this state of affairs is usually brought about by making each lamp feed a limited portion of the total area to be lit up.

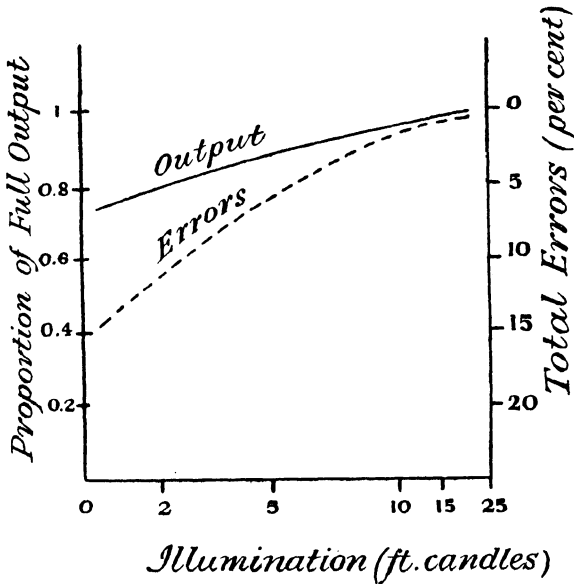

FIG. 56.—EFFECT OF ILLUMINATION ON COMPOSERS' OUTPUT: FULL LINE—OUTPUT; BROKEN LINE—ERRORS (after *Industrial Fatigue Research Board*)

Suitably shaped reflectors round the lamps may be designed to do this, but occasionally an absorber may be used to better advantage, although it must be remembered that absorption means conversion of energy into what is, from the present point of view, useless forms. One desirable place for absorbers is in the mouths of flood-lamps where dark rings of metal are sometimes placed, coaxial with the beam, to absorb any light sent out from the reflector at oblique angles which would stray out of the field of illumination; at the same time they do

not interrupt the direct beam, to whose axis they are tangential.

Inside a building diffusion of the light is often used to produce uniformity of illumination, especially as the glare from direct lights may thus be avoided by fitting a combination of reflecting and diffusing glasses. The lamp is hung under a white or cream ceiling while beneath it is a pendant diffuser of pearl glass, usually a saucer or other shallow shape. If the density of the glass is so chosen that it appears from below about as equally brilliant as the ceiling, then the combination of reflected and partially refracted light will be free from glare throughout the room. Of course, it is possible to have the glass of the lamp bulb itself 'frosted,' but this makeshift does not result in overall equality of illumination.

Other schemes of interior lighting dispense entirely with direct lights. The lamps are then hidden from the view of persons in the room by being set into the jambs of the wall panels where they adjoin the ceiling, which is curved to such a shape above the line of lamps that, in spite of its matt surface, it succeeds in diverting a certain amount of light to floor level according to the recognised laws of reflected light; whereas the flat part of the ceiling scatters the light downwards by less regular reflection. The entire light at reading level is then derived indirectly by reflection from the ceiling. Unless the disposition of the lamps is carefully carried out, the ceiling may have a patchy appearance, which is undesirable even if it does not spoil the uniformity of brightness lower down.

Though the absence of visible lamps is a desired feature of certain types of architectural design, it is naturally more costly to rely entirely on reflected or diffused light, since luminous energy is wasted at every such reflection or refraction. The practice is therefore confined to restaurants and auditoria where reading or needlework is either discouraged or provided for by desk lamps. In particular, cinemas and theatres may be lit effectively on this principle, because daylight does not penetrate. As unshuttered windows constitute secondary sources of light in daytime, their presence does not lend itself

to the scheme of hidden sources of diffuse light, except perhaps in those studios where the whole of the north wall is glazed with frosted panes.

The lighting of theatres and cinemas presents special problems to the illumination engineer. An audience's view of the stage is derived entirely from indirect lighting. Footlights, winglights, and skylights provide local illumination for different parts of the stage while the 'limes' (which nowadays are usually incandescent or arc lamps of high power) in the auditorium can be used as spot-lights or to add to the general illumination and provide such shadows as the producer desires. In some plays use is made of an illuminated back cloth in lieu of the conventional painted scenery, which it may replace with good effect. While the curtain is up, all other lights must be doused or shaded to avoid glare; especially, the musicians' desks should not be lit up in such a way as to distract the attention of the audience.

The screen in a cinema must be a good reflector and yet free from gloss. When coloured films are to be shown it must be truly white and not produce colour distortion by the favoured absorption of certain tints. Because the stark whites and blacks of the original cinema film are rather tiring to the eye, architects attempt to provide visual relief by having soft coloured lighting round the edge of the screen or having transforming coloured beams play upon the screen itself during the short intervals between the showing of pictures.

The modern architect realises that lighting need not be employed purely for functional purposes, that is, to make seeing possible in a darkened room or to relieve the eyes in the way we have just noted. Lights may be used as part of the design itself purely for scenic reasons. One may see, especially in theatres and restaurants, strip lighting used to emphasise the lines of the design; to pick out the line of a proscenium arch or to colour the jet of a fountain. Such lighting, since it is not intended to help people to see clearly but is purely formal, may be provided amply enough by the gas-discharge lamps, neon, etc., which are now so common in towns out-of-doors and

whose running costs are very small in comparison with those of the incandescent lamps or arcs used for authentic lighting.

One of the most important questions which confront architects at the present day is how to ensure that their designs shall have good acoustic properties. For too long this has been a matter of 'hit or miss' on their part, and it is largely due to the pioneer work of the late Professor Sabine that a technique has been evolved, which in its simpler if not in its higher aspects may be followed by an architect with but little training in science. In the classical days of the open-air theatre the problems were simplified, for there was little or no reverberation. Sound from the stage passed over the ears of the audience and then beyond the rear wall of the auditorium never to return. But the modern auditorium is an enclosed space; sounds produced within travel to the walls, are there reflected, and continue to ricochet until damped out of existence like the ripples on a small pond excited by stirring with a stick. The phenomenon is aggravated where the walls are good reflectors. When such a state of affairs subsists the sound from a musical instrument or voice reverberates for long after the actual tone production by the source has ceased. It is this reverberation which, in its excess or deficiency, is the origin of the greater part of the faulty acoustics with which some lecture and concert halls are cursed.

In order that each member of the audience may hear each syllable or note distinctly, it is necessary that the sound in his vicinity should rise to a sufficient intensity and then die away quickly to give place to the next note. The two desiderata of adequate loudness and rapid decay are to a certain extent mutually exclusive, for while one can get rapid decay by having highly absorbent walls or no walls at all, such a remedy reduces the overall loudness. This makes it hard work for a speaker, and, in fact, the actors in the old Roman theatres had to use masks incorporating a speaking trumpet in order to be heard properly in the open. Nowadays one can make up the intensity with loud-speakers. Loud-speakers are not by any means a cure for excessive reverberation, which is overcome

by properly proportioning the total amount of absorption in the hall to its volume. The absorption can be totalled by multiplying the area of each material by its appropriate absorption coefficient and summing the products, with a due allowance of a certain number of units per head for the audience expected to be present. The reason why a large hall demands more absorbent than a small one is apparent when one considers that in the former the sound-waves have to travel

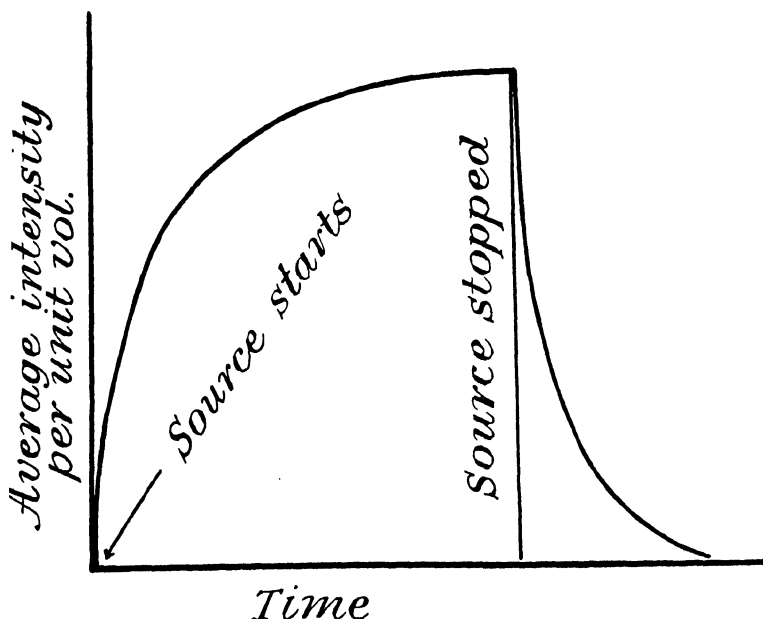

FIG. 57.—RISE AND DECAY OF LOUDNESS IN AN AUDITORIUM

farther between successive reflections than in the latter; the lower frequency of collisions with the absorbing walls must then be compensated by a greater percentage removal of energy at individual collisions.

Fig. 57 indicates the rise and fall of loudness in a room due to the successive starting and stopping of a note of constant pitch or single syllable. The height of the curve at any instant of time represents its loudness as perceived by a listener. The loudness rises rapidly at first, then more slowly

till it reaches a 'level' which persists until the source ceases to emit that particular note; the instant of cessation is shown by the vertical line; thereafter the loudness falls rapidly at first, then more slowly until it cuts the time axis. This is the 'time of reverberation.' It will be obvious that when a rapid succession of notes or syllables is uttered there will be certain time intervals during which the ears of the listener are subjected to sounds originating from two successive syllables. If they are extensive, as they are in an over-reverberant room, hearing will be difficult. In very large bare halls there may be a true echo—that is, an intermission of silence between the direct sound and its reflection from the ceiling or a distant wall, though echoes are more characteristic of outdoor conditions.

To every hall of a certain volume there corresponds an acceptable time of reverberation. This standard time may be assured, if the correct amount of absorption is given by the materials and persons within it. Strictly speaking, the correct reverberation is only attained with a certain number of people present, but extremes of variation in the numbers of audience may be atoned for to some extent by the provision of curtains to be drawn aside when the numbers exceed a certain figure or of upholstered seats to make up some, at any rate, of the absorption yielded by the absent sitter. In the early days of assessment of absorbing characteristics it was usual to provide a slightly higher unit for a female member of the audience than for a mere male on account of the greater surface of clothes presented; but such nice distinctions are not really warranted by the accuracy possible in reverberation adjustment, if indeed the figures would not require reversing at the present time!

Another variation in absorption should be made if the hall is to be used for a lecture or spoken play, as opposed to music. Musicians prefer a more 'resonant' concert hall. This is secured by a slight increase in reverberation time and the provision of wood panels which, by resonant response in the bass, intensify this part of the gamut and increase the general reverberation. Such provision has to be of a permanent

nature; it is not feasible to produce such a profound change in design as a temporary expedient; nothing better than the drawn curtains can be offered as a temporary measure when frequent change in the type of performance is encountered.

Once the reverberation time has been properly adjusted, if the conditions prove tiring to a speaker by reason of the absence of expected reflections from the walls, the source can be put up to any desired level of energy by having him speak softly into a microphone and relaying the amplified voice from suitably placed loud-speakers; this is the so-called 'public address system.' Theory indicates that the power of the source should vary as the square of the cube root of the volume of the room, or as the square of the average linear dimension.

Professor Sabine measured his times of reverberation with a standard organ pipe and a stop-watch, and the absorbent surfaces which he employed to reduce the time by a measured amount consisted of cushions laid on the wooden seats of bare lecture-rooms. His absorption units were therefore estimated in square feet of cushion. He afterwards rated the absorbing power of his cushions against a corresponding area of open window, ascribing to the latter an absorption coefficient of unity, since all the sound falling upon it was dead as far as the interior was concerned. Nowadays there are elaborate reverberation meters consisting of a constant pitch or 'warble tone' to give an automatic record of the time which elapses between the cutting off of the source and its fall to the limit of audibility. Some instruments, indeed, record the instantaneous loudness in the room while the sound decays. It is then seen, as one would expect, that while Fig. 57 gives the general layout of the energy rise and decay curve, actually it fluctuates considerably about a mean curve of this shape. A more precise analysis still, such as one gets from a microphone coupled to a cathode-ray oscillograph, shows that the waves which ricochet from wall to wall during the reverberation period are largely composed of the natural vibrations of the body of air enclosed in the room.

Although the reverberation time is, within limits, indepen-

dent of the shape of the walls in relation to the position of the source, yet the loudness received by auditors in different parts of the hall is not. Large curved surfaces at the back of the hall or in the ceiling tend to focus the sound on certain points, producing greater intensity there to the detriment of less favoured spots. In such a building if an organ pipe be blown at constant pressure at one point, a listener walking about will hear changes in loudness at different points, quite apart from the more localised variations due to the diffraction pattern set up. These undesirable variations occur if there are large and unbroken curved surfaces to act as colossal mirrors, and the remedy adopted is to break up the surface in such a way that the sound is irregularly reflected and so distributed more evenly about the hall. It is, in fact, the same device that is used to secure uniformity of *illumination* by the use of diffusing reflectors, to which we referred earlier in this chapter. Only, the wave-length of sound being so huge in relation to that of light, the roughening of the sound reflectors corresponding to the frosting of glass must be on a correspondingly large scale. It may be done by incorporating cavities, several feet across, ornamental excrescences or large pendent lamp-holders, chandeliers, etc., in the ceiling. If the adjustment of reverberation period indicates the need to apply special absorbent material, the expert looks for such a curved surface for the treatment, with the object of abating its focusing propensity.

Curved surfaces are particularly noisome when found in a high vault or dome, as an echo from such a surface will be enhanced to an unfortunate member of the audience who happens to be near the focus. There is, however, one advantageous position for a curved surface, and that is just behind the source, where it acts like the reflector placed behind the bulb of a driving lamp. The energy reflected follows so closely on the heels of the direct sound that they arrive practically in phase at the ears of members of the audience, contrary to that from more distant reflecting boundaries which makes for hardness of hearing. This is the object of

the shell-shaped alcove in which a small orchestra often plays and of the large parabolic structures placed behind the pulpits in some modern churches; but the flimsy little sound-board of olden days was of little use for this purpose.

As a matter of guiding principle the architect is well advised to make all the possible paths, direct, once or twice reflected, by which the sound can reach an auditor as nearly equal as possible. Churches, and especially cathedrals, have unusually high roofs and, with the choir singing in the chancel, this prevents the adoption of the equal path principle. The usual position of the organ in a church is not one which would commend itself to acoustic theory. It is too frequently tucked away in a side-chapel, so that the majority of the pipes can only be heard by diffraction or by reflection from the opposite wall. As the organ cannot be placed at the east end in most churches, the best position from the acoustic point of view would appear to be the west gallery—with the choir in front—or in its ancient position over the screen that separates chancel from nave. The objection to this has always been that the heavy screen required cuts off the vista down the aisle, but with modern methods of girder construction this objection should fall. If the organ music is electrically produced and relayed to loud-speakers (*vide* next chapter), these problems largely vanish since cumbersome ranks of pipes are replaced by small and light loud-speakers which can be located in the most suitable acoustic positions without regard to spatial considerations.

Before leaving this part of the subject it behoves us to give some account of the means adopted by the physicist to supplement the rather limited information which the architect can get of the acoustic properties of a new design by tracing ray paths in the way we have indicated. The alternative and more precise procedure for spotting undesirable foci, echoes, and dead spots in the design is to construct a rough scale model—both a vertical section and a horizontal section—out of wood, and to trace the course of sound-waves in the model by using the sound of an electric spark as source. Fig. 58 shows a typical apparatus as used at the National Physical

Laboratory for this purpose. It consists of a long wooden box about one foot square and twelve feet long, with the sound spark gap located near the middle. At one end is another spark gap across which a light flash can be produced at will at a fraction of a second after the sound spark has 'gone off.' (Both are initiated by the discharge of condensers, with a circuit timed to produce any desired lag of the light behind the sound.) At the other end of the box is a photographic plate on which a shadow is cast of the projection upon it of the sound-wave at the instant it was 'snapped.' The com-

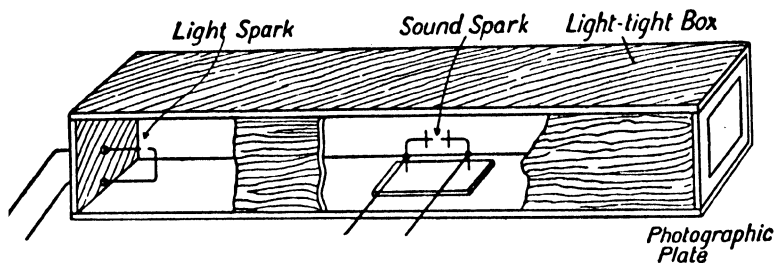

FIG. 58.—SPARK PHOTOGRAPHY APPARATUS (*National Physical Lab.*)

pression produced by the discharge across the spark gap of the charge on the condenser is so intense that over the wave-front the air has abnormal optical properties and refracts the light so that the wave-front appears outlined on the plate as a sharp line, in rather the same fashion that the view seen through hot air appears 'wavy,' except that then it is heat and not sound which gives the air unusual optical properties. If nothing comes in the path of the sound-wave, its wave-front is a sphere whose projection on the photographic plate is a circle, but if the wave has collided with the boundary of the model section which is placed around the spark gap, then, of course, reflection occurs, and the wave-front doubles back upon itself. By taking a series of such photographs at various time intervals of lag between the sound and the light spark the course of the sound-waves in the model may be followed and alterations made in the section in such a way as to promote more even distribution of the sound.

Fig. 58, Plate V, shows a spark photograph of the sound-waves traversing a model vertical section of the County Hall, London, from a 'speaker' represented by the shadow of the large knob which forms one of the electrodes. The boundaries at which the respective reflected waves have arisen are readily traced in the picture.

Another method involves the laying of the model sections on the floor of a sink having a glass bottom and a layer of half an inch of water. Ripples are sent out from a desired point by dropping in a pellet, and the course of the ripples followed by taking a cinematograph film of the motion. The photographs, however, obtained in the ripple tank are not so clear-cut and easy to follow as those which are obtained in the spark camera.

Air conditioning in buildings and public service vehicles is a subject which is receiving increasing attention in this and other countries, though since Great Britain is entirely in the temperate zone and every part of it lies within seventy miles of the sea, air conditioning is not so urgent as in the extreme climates of America or in the centre of other continental massifs. The work to be done may be summarised as follows: (1) removal of spent air and dust, (2) introduction of clean air at a suitable temperature, and (3) endowment of the air with adequate humidity. Since the first two come under the heading of ventilation they can be considered together. The motive power will usually be a fan which exhausts the bad air from the enclosure into the atmosphere and replaces it by fresh air brought to a comfortable temperature by passage over hot plates or ice according as the atmospheric temperature is lower or higher than the desired value (usually about 60° F. for white peoples). The fan produces a certain pressure gradient along the conduit, and this draws a current of air whose mean speed is related to the pressure drop producing it by a factor dependent on the form and diameter of the cross-section of the channel and variously called the conductance or resistance of the channel, according as one thinks of the walls as assisting or retarding the flow. The

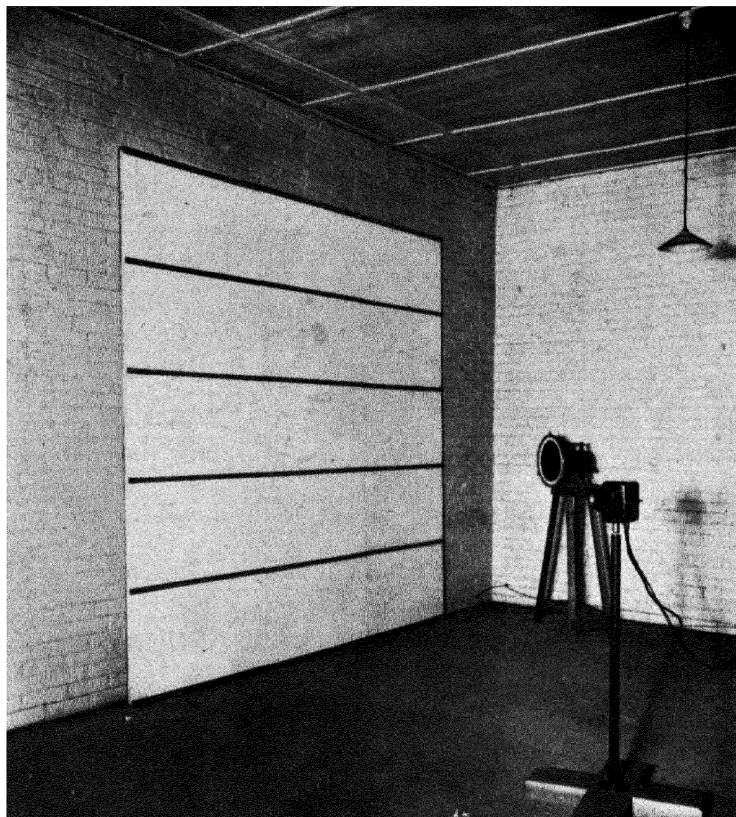

FIG. 53.—ACOUSTICAL LABORATORY; ABSORPTION OF LARGE SPECIMENS  
(*Newall's Insulation Co.*)

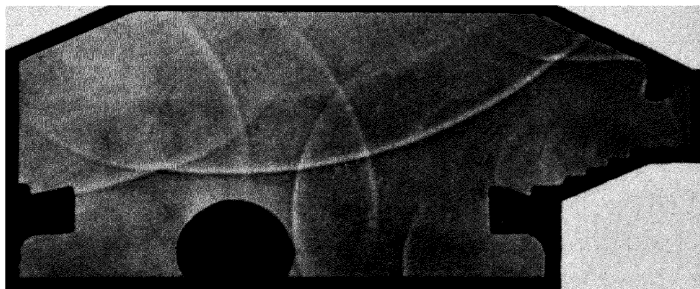

FIG. 59.—SPARK PHOTOGRAPH TO ILLUSTRATE SOUND PROPAGATION IN  
AUDITORIUM (*Davis*)



engineer must put in a fan and motor of such power that, allowing for frictional and turbulent losses, the air in the room is changed at a rate adequate for the number of persons expected to be present. It is usually reckoned that two or three thousand cubic feet of air must be changed every hour for each person in the enclosure.

The air current is estimated from the readings of a meter placed in each of the intake vents to the room in succession and integrated for the whole system by multiplying the velocity of each draught by the area of the trunk at the point of insertion of the meter. Sometimes the Pitot tube (cf. p. 53) is used in this connection, but as this involves making holes in the side of the trunk for the insertion of the static tube, a meter which can just be placed a foot or so inside the vent is preferred. The vane anemometer is most favoured by ventilation engineers. This consists essentially of a little windmill and a revolution counter. If the area of the 'disc' of the mill through which the air passes is known, then every revolution of the blades corresponds to so many cubic inches of air passing through. Knowing this calibration factor, the number of revolutions recorded per minute may be converted into so many feet of air passing through in one minute, which is, in fact, the speed of the draught in feet per minute. There is usually a correction factor to be added to the readings of the instrument. This is given by the manufacturer, who compares the readings of each instrument with the velocity of the same stream indicated by a combination of Pitot and static tube. Further, the readings must be corrected if the density of the air changes from the standard at which the manufacturer performed his calibration, that is, if the temperature and pressure of the air are different. The correction for this cause becomes less important as the speed of the draught goes up.

Another type of anemometer which may sometimes be seen in use in ventilation systems is the deflection plate. This is a small plate of metal pivoted about one edge on a horizontal bearing and having a pin which continues below the pivot in the same vertical plane and terminates in a counterweight which

holds the plate vertical in still air. When the wind blows upon it, the plate deflects back through an angle which can be taken as a measure of the air speed and is measured by the movement of the pin over an angular scale. Generally speaking, the swinging plate is not so accurate as the rotating vane, especially at low speeds.

In elaborate systems, automatic control of the temperature of the air supply is assured by thermostats. When the temperature rises above or falls below a certain tolerance, air is diverted over the cooling or heating pipes as the case may be through the intermediary of relays which operate shutters in the pipe assembly. If all the inlets and outlets of the room are vents for the circulating system, the same fan which draws the air in can drive the exhaust out. To secure efficient circulation the positions of exits and entrances must be so arranged that the air has to pass through the entire room before being liberated. The radiators of the central heating system can be called upon to assist by the convection currents which they set up in their vicinity.

We may remark here, though a little late in the book, that a system of ventilation in mines has to be set up on similar principles to that which we are now discussing for buildings. It is most vital in mines that every working gallery shall be adequately ventilated both for the sake of the health of the pitmen and also for their safety, in case there may be a leakage of explosive gas into the workings. Formerly the necessary draught was induced by lighting a fire at the base of one of the shafts, but, because of the danger of explosion and spreading of the fire into the workings, this is no longer permitted and the draught is induced by powerful fans aided by the proper location of doors, etc., in the galleries to force the air to circulate overall before being exhausted back into the atmosphere.

It is obvious that for such a system of forced ventilation to work efficiently there must be no other places of ingress or exit of the air than those in the official network set up by the engineer. In a room, open doors, windows, and fireplaces

are such disturbing factors. Central heating must therefore be employed in the building in winter to make up for the heat lost by conduction through the walls, although in small rooms and railway carriages the heat supplied to the entrained air may be considered adequate without the use of radiators.

In order that human beings may live comfortably indoors the humidity must be adjusted as well as the temperature. It is well known, for instance, that the body can stand extremes of hot and cold climates—particularly the hot ones—with less discomfort if the climate is very dry than if the air is saturated with moisture. In ordinary living-rooms it is usually reckoned that a humidity of 50 per cent. of saturation is desirable. In cotton mills the humidity has to be much nearer the saturation value; this for the proper treatment of the textile fabrics rather than for the comfort of the textile workers. The criterion of humidity control is then not the absolute value of the moisture content of the air but the humidity relative to the maximum amount which the air will hold at a particular temperature. This maximum varies with temperature. For instance, the pressure of water vapour when it saturates the air at 50° F. is 10 millimetres, whereas at 60° F. it is 15 millimetres. If the actual vapour pressure prevailing in the air is only 5 millimetres, this represents a relative humidity of 50 per cent. at 50° F. but only 33 per cent. at 60° F. The relative humidity is determined in practice by the ‘wet and dry bulb thermometer.’ This is actually a pair of thermometers, one kept dry, but the bulb of the other kept wet by means of a wick dipping into a little well of water. The first one reads the ordinary room temperature but the other reads lower because its bulb is being constantly cooled by evaporation. The rate of evaporation depends on the prevalent humidity of the air, so that the difference of the two readings can be related to this same.

Other hygrometers—as these instruments are called—of a less exact type use the fact that the length of fibrous materials varies with the local moisture content. A strip of paper or a hair is often used. Normally it is coiled up so that its stretch-

ing may be made to push a pointer over a dial. Most desk hygrometers are of this type.

The readings of all hygrometers are affected by local air currents. If, for instance, the wet and dry bulb hygrometer is so carefully shielded from draughts that the wick saturates the air in its vicinity, evaporation will cease and the two thermometers give the same reading. To prevent this the instrument may be placed in a glass cylinder and a constant slow air current aspirated past the bulbs by a clockwork fan; or it may be put on the end of a sling and whirled round in the air at a fixed rate before a reading is taken.

The correct humidity is usually given to the air by fine sprays of water in the ventilation ducts sufficient to saturate the air at such a temperature that when subsequently heated to the correct room temperature what was 100 per cent. humidity at the lower temperature becomes 50 per cent. (or other desired value) at the room temperature. After passing the sprays, excess water in the air falls into a trap and in doing so lays the dust. The spray water ought to be heated before it is injected, otherwise heat is taken at the expense of the air to warm up the water and vaporise it. If this pre-heating is not done, a drop in temperature in the trunk will be evident just beyond the spray chamber.

#### SOURCES

- H. Bagenal and A. Wood: "Planning for Good Acoustics," 1931.  
 A. H. Davis: "Ripple and Spark Photography in Architectural Acoustics" (Proc. Phys. Soc. **40**, 87, 1927).  
 A. H. Davis and G. W. C. Kaye: "Acoustics of Buildings," 1927.  
 J. A. Meyer and R. U. Fittz: "Air Conditioning," 1933.  
 C. G. Paterson and Others: "Symposium on Illumination."  
 E. H. Penwarden: "Architectural Aspects of Illumination" (Parthenon, **13**, 358, 1939).  
 E. G. Richardson: "Introduction to Acoustics of Buildings," 1933.

#### JOURNALS

Architect; Parthenon; J. Roy. Inst. British Architects; J. Optical Soc. Amer.; J. Acoustical Soc. (Amer.).

## CHAPTER XIII

# SCIENCE AND THE MUSICIAN

MUSIC is an art, but the production of music other than unaccompanied singing would be impossible without some science of musical instrument construction, though for centuries this science lay almost unrecognised beneath a heavy load of empiricism. It must be admitted that the scientist has barely caught up with the musical instrument maker with his cut-and-try methods in many fields but is still labouring to set this empirical knowledge, in so far as it concerns established instruments and methods of music making, on a sound scientific basis. Yet already advances have been made with new instruments and possibilities of new forms of music have been evolved as a result of the knowledge so gained by the scientific musician and engineer.

Most of the instruments of ancient and modern times employ either vibrating strings or reeds or vibrating lamellæ of air in combination with resonators in the form of cavities or columns of air in enclosures. In every case there must be a means of excitation and maintenance of the sound once produced. Most musical instruments therefore comprise a coupled system in which one partner acts as a sort of trigger to keep the mechanism going by providing periodic impulses, while the other decides the frequency at which the vibrations shall be maintained.

As a simple example of a coupled system, one may cite that formed by a string pendulum suspended from some point along a cord, one end of which is fixed to a peg. If the free end of the cord be swung to and fro, the pendulum will be forced into vibration at a period corresponding to that of the force applied to the free end. If, however, the period of agitation happens to coincide with the natural period of the pendu-

lum, namely, that at which it would swing if displaced and let go, it builds up a large vibration. The latter case is, in fact, an illustration of resonance. If the period of the vibration forced upon the pendulum be one unnatural to it, the extent of its response depends on how strongly it can conserve its natural vibrations. Thus a pendulum with a light bob can be forced into synchronism with the hand agitating the rope, whereas one with a massive bob will let such influences pass over it unnoticed, unless their frequency happens to march in step with its own. The hand agitating the rope and the pendulum form a coupled system. A very heavy pendulum might force its natural period upon the hand and take control of the frequency. For the successful maintenance of a coupled system it is indeed essential that one of the components shall be capable of overriding the other. If this is not so, they will vibrate at sixes and sevens and soon be brought to a stand. In many musical instruments it is the column of air which decides the frequency, overpowering the exciting mechanism and forcing it into its own frequency. This is the case with organ pipes. On the other hand, in most stringed instruments it is the string which determines the frequency. The resonant cavity or sound-board has to follow suit. In the former class the relation between the components is rather like that between the escapement and the pendulum of a grandfather clock, where the slow fall of a weight working through the escapement keeps the clock going, but the *rate* at which it goes is entirely settled by the natural period of the pendulum.

As an illustration of the first type of system we will take the ordinary flue pipe of an organ as exemplified by the diapason stop, which forms the foundation of organ tone: This (cf. Fig. 60) has the two components: edge tone at the mouth, column of air in the pipe. The edge tone is formed by the air debouching under pressure from a slit at the mouth of the pipe and falling upon the bevelled lip fashioned out of the wood or metal plate out of which the pipe is built. As a result of instability the emergent lamella of air is set into pendulation as vortices become detached alternately on either side of the

slit. In the absence of the resonating column of air this edge tone would have its frequency decided by the height of the mouth—distance from slit to edge—and the wind speed. But the more powerful column of air is able to insist that the frequency at which the system is to vibrate shall be one of the natural frequencies of which it is capable. The result is that the column pulls the feeble edge tone out of its true habitat into whichever of the natural pipe frequencies lies nearest to it. As the frequency of the edge tone rises with blowing speed,

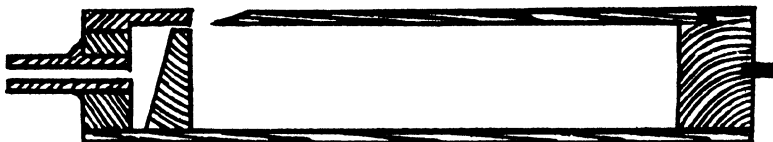

FIG. 60.—FLUE ORGAN PIPE

this means that when the wind is turned on to the pipe and its pressure slowly increased, first the lowest tone (fundamental) of the pipe is elicited, then—if the pipe is open at both ends—the octave of this, later the twelfth, and so on. If, on the other hand, the two partners were equally strong, they could only work together if the wind speed were so nicely adjusted that the frequency of the edge tone exactly equalled one of those proper to the pipe. It is fortunate for the organ builder that it is otherwise. Actually the behaviour of the pipe is a little more complicated than we have represented it to be, since the octave usually appears before the fundamental has vanished, but this fact does not affect the validity of our explanation.

In a number of wind instruments the exciting agency is a reed or a pair of reeds at the mouth of the pipe, excited by the wind from an artificial or (in the orchestra) human chest. The reed as an exciter and maintainer of a column of air is perhaps easier to understand than an eddy system. A vibrating strip of metal or cane clamped at one end has a fundamental frequency determined by its length, thickness, and elasticity. The overtone frequencies bear complex ratios to this fundamental, whereas those of a column of air are har-

monic; that is to say, they are in the ratio of simple whole numbers. When the reed is coupled to the pipe its inharmonic overtones are suppressed because they are not reinforced by the column of air. The working of the reed when blown is somewhat as follows. As the air rushes through the space between the free end of the reed and the bearing upon which it is clamped it tends to widen the space and pushes the end of the reed away from the bearing table, but the reed, being elastic, when deflected is able to slide back past the onrushing air and moves so as to close the gap. It then springs back when the widening of the gap is again promoted by the pressure of the air, and so on.

The relations between the note of the reed and that of the pipe are similar to those between the two members of the

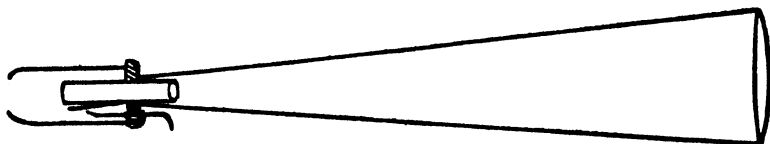

FIG. 61.—REED ORGAN PIPE

flue-pipe system, except that the reed can vibrate only at certain fixed frequencies, whereas the pitch of an edge tone rises continuously with the blowing pressure. If the pipe is in tune with the reed, it is possible to vary the wind pressure over a large range without fear of the note jumping to an overtone. The construction of a typical organ reed pipe is shown in Fig. 61. The wind enters by an orifice on the left into the 'boot,' which forms a short supply-tube to the pipe. This contains the reed, clamped at its upper end to a little tube attached to the roof of the boot. The pipe itself, usually conical in shape, fits tightly over the projecting end of the reed tube. The reed is tuned by a bent wire which presses it against its table at any required point. This shortens the effective length and raises the pitch. Since the supply-tube contains a considerable cavity, it is desirable that it too should be of such a size as to be in tune with the reed and column of

air in the pipe so that all three partners, pipe, reed, and supply-tube, may co-operate harmoniously.

What was said about the pipe forcing its pitch upon the weaker edge tones applies with equal force to reed pipes, with the proviso that the thicker and stiffer the reed is, the less will it be at the mercy of the pipe. Organ reeds are always made of light and elastic metal. On the clarinet the reed is so thick that it is more difficult to hold it in bondage to the column of air in the instrument, but the player can to a certain extent adjust the natural frequency of the reed when he changes the effective length of the column for the production of various notes by pressing the fixed end of the reed more tightly upon the table with his lower lip for the higher notes.

It remains to speak of the third type of pipe maintenance, that peculiar to the orchestral brass. To a certain extent the scheme is an imitation of the mouthpiece of the oboe, a wood-wind instrument employing two light cane reeds of which the two free ends leave a narrow chink which serves the same purpose as the gap between the clarinet reed and its table. On the brass the player's lips perform the functions of such a double reed. The lips are compressed into the circular rim of the cup-shaped mouthpiece and by means of the osculatory muscle the player can alter the tension and vibrating length of these soft reeds to correspond with the frequency of the tone which he wishes to elicit from the column of air within the brass tube. In early brass instruments—still in the post-horn and bugle—the series of possible tones was limited to the fundamental and harmonics of an invariable tube. Modern orchestral brass instruments have a somewhat more extensive compass, for by operating pistons three or four additional lengths may be brought into action so that the player has at his disposal the harmonic series based on three or four different fundamental lengths of pipe. Armed with these alternatives he can bridge within a more limited range as many semitones as are possible to the pianoforte. Exceptionally, the trombone player has a continuously variable length of tube to play upon, the tube being extensible through

the movement of a sliding piece. In practice, however, he uses only a limited number of set positions of the tube—and their harmonics—like his brethren of the horn and trumpet.

A feature of the wood-wind which, until recently, was decided by empirical methods, has now been rationalised by the physicist. We refer to the location of the side holes which determine the scale which the instrument will play. Among primitive peoples it is the custom to bore these holes so that they form a pleasing pattern easy to cover by the fingers, without regard to the scale which the musician may hope to execute. Thus in many instruments made by the North American Indians we often find that six holes are bored into the front of a tube or cane from which the pith has been removed by another heated stick. Three of these holes form an equi-spaced group which the left hand of the player operates. Other three farther down the tube are closed by the right hand. Two holes at the back are worked by the thumbs. The primitive instrument is completed by a whistle or reed mouthpiece fashioned from the same or another piece of wood. The scale of such an instrument is made available by first covering all the holes, which then gives the 'speaking length' corresponding to the complete tube; then shortening the effective length by uncovering them in turn, starting with the one farthest from the mouth. Intermediate notes between the six or eight so available are obtained by 'cross-fingering'; for example, the note when holes 1, 2, 3, and 5 are covered will be intermediate between that when 1, 2, 3, 4 or 1, 2, 3 respectively are closed. Later, keys were added, as in the 'recorder' of Elizabethan times—lately revived—to operate additional note holes too remote or inconveniently placed to be worked by the fingers directly.

The simple theory that the effective length of the tube may be reckoned as running from the mouthpiece to the first open hole is obviously inadequate, as we have shown above by pointing out that the note with holes 1, 2, 3, and 5 covered is flatter than that with 1, 2, and 3 covered; number 4 being the first open hole in both cases. Formerly it was not possible

to calculate the effect of uncovered holes beyond the first open one. The theory of acoustic impedance now permits of the calculation of the position and size of the side holes in such cases, corresponding to a predetermined arrangement of fingering. This can be done in advance of the construction of the instrument, so that one does not need to waste good wood as in the old trial-and-error methods.

A factor which wind instruments exhibit to a greater degree than others is a change of pitch with temperature. This change has its origin in the expansion of the contained air which in turn causes a rise in the velocity of sound in the said air. This is awkward when wind instruments and strings play together in an orchestra. It is a tradition that the oboe shall give the tuning note to the remainder of the instruments, although it is equally affected by temperature with other wind instruments. There seems to be some confusion on this subject. One sees it stated that the rate of change of pitch with temperature is less for an orchestral wind instrument than for a pipe organ. In fact, the same laws govern both, but since the orchestral instrument is largely filled by the expired breath of the player, its temperature naturally varies less than does that of the air in the room, which aspirates the organ pipes, with climatic conditions. Consequently the pitch of the former shows less variation as the temperature *in the room* changes than does the organ. The playing together of pipe organs and orchestras has been one of the stumbling-blocks to the introduction of a standard pitch to which all orchestras and soloists shall tune, but this will be overcome if electrophonic instruments (*vide infra*) replace the pipe organ, though the wood-wind player may still find difficulty in adjusting his instrument to a universal pitch when playing in hot climates.

While the bell or flare at the end of a wood-wind instrument has little effect on the quality, except when the whole length of the tube is being employed, on the brass instruments it does fulfil some important acoustic functions. It is common nowadays to give the section of this expanding end an expo-

nential curve, because—again working on impedance principles—one can show theoretically that this is the best shape to get the sound efficiently radiated from the open end of the tube. The steadily increasing curvature imposed upon the sound-waves as they pass along the tube transforms them gradually from plane into spherical waves, in which form they must expand into the room, whereas the waves travelling along a straight cylindrical or conical tube must have their curvature sharply changed at the end of the tube, which impedes their efficient spreading out beyond the end. In actual manufacture the tube is made slightly conical from the mouthpiece until near the end, where it widens out rather suddenly. If the rate at which the tube bellies out is large, the intensity of the upper overtones in the note is reduced and the quality becomes mellow. For this reason the orchestral horn has a more mellow tone than the trumpet. If the flaring is carried too far, the instrument will lose its resonating characteristics and it will be difficult for the player to elicit the tones natural to the column of air. In the extremity, we have the pronounced exponential flare of the loud-speaker, where the object of the designer is to reduce natural frequencies to a minimum and to get uniform response over the whole musical gamut.

The same requirement is demanded of the sound-board and aerial cavities in stringed instruments. The stretched string is capable of producing the whole series of harmonics based on a fundamental tone whose wave-length is equal to twice the length of the string. Thus the violinist runs up the scale by stopping the vibrating portion of the string short with the finger of the left hand, so that a note of higher pitch is produced. The quality of the note of any stringed instrument is decided by two factors: (*a*) the position and extent of the region of the string over which the excitation takes place; (*b*) the nature of the sound-board or other resonator to which it is coupled and the strength of the coupling. As regards the first of these, we may point out that if one particular harmonic in the complex note of the string demands a node at the point of excitation, that harmonic will be but weakly elicited, if at all;

and that, generally speaking, if the agent which starts the vibration acts on a considerable length of the string, the timbre will be more mellow—that is, high harmonics will be absent—than if the exciting force acts at a single point. Thus the quality of the banjo, in which the strings are plucked either by a piece of horn or the finger-nail, is more incisive than that of the harp, in which the fleshy part of the hand is used to start vibration.

The sound from an unassisted wire is but feeble. All stringed instruments have some form of sounding body of larger surface to which they are coupled to reinforce the sound. This will partake in the vibration but will lend it qualities of its own, derived from its natural resonances. These should be so distributed that all the tones which the player is likely to elicit are equally amplified, a thing more easily said than done. The pianoforte sound-board must vibrate, as far as possible, all in one piece if it is to radiate the sound efficiently. If differences of phase exist over the surface so that parts are moving in while others are moving out, their efforts upon the air will cancel out and much of the reinforcement will be wasted. On the violin, since it has a smaller surface, such bad conditions are less likely to arise. Nevertheless, it is important for this very reason of small radiating surface that the string vibrations shall be well coupled to the belly. This is secured by having a 'sound-post' beneath the bridge, a wooden peg which spans the space between the front and back boards and makes them vibrate in concert. Shifting this post a little is one of the ways in which the maker—and the player, too, if he has an experimental turn of mind—can alter the quality and intensity, since such a movement virtually alters the tightness of coupling between the string and the two radiating surfaces.

The criterion of a good amplifier is that it should give prominence to the fundamental and yet have resonant peaks well distributed over the musical gamut. Poor instruments have an excess of overtones, especially of the fifth harmonic, overshadowing the fundamental. Fig. 62 shows the change in

the disposition of the partials in the acoustic spectrum of a 'cello when the relative positions of sound-post and bridge were changed. (The heights of the triangles represent relative intensities of overtones.) The uppermost is the spectrum of the 'cello originally; the central one shows how a shift of the bridge lowered the amplitude of two peaks between 1,000 and 2,000 vibrations per second; the lowest is the final effect after bridge and sound-post had been set to get a sound most pleasing

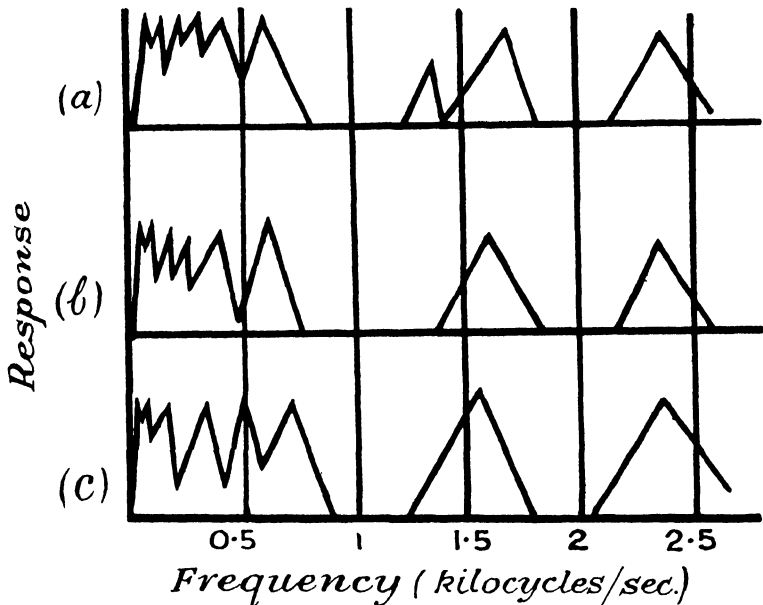

FIG. 62.—ACOUSTIC SPECTRA OF 'CELLO BEFORE AND AFTER CHANGE IN POSITIONS OF BRIDGE AND SOUND-POST

to the ear, all peaks now being of a size. To go from the sublime to the ridiculous: many cheap violins have such prominent and badly distributed resonances that if the player happens to light on one of these by stopping the string to such a length as to bring string and belly exactly in tune, the instrument will set up an excessive and unpleasant vibration, known to players as the 'wolf note' but which often can be traced as a rattling of the whole structure.

That the nature of the material and tension put upon it is one of the salient features in a good sounding instrument has always been recognised. This is one of the factors which distinguish the work of the old Italian masters, though the theory that there was something in the varnish they used to give the excellent quality is rather discounted by scientists. At any rate, X-ray analysis is now being brought to bear upon the structure of the wood of old violins, to see if any unsuspected features of their material may be brought to light.

It is constantly a source of controversy between musician and physicist whether the player can put anything into the playing of an instrument which an efficient machine could not do. Apart from artistic judgment as to when to play fort $\acute{e}$  and when to play piano and such like matters of individual taste, is there, for instance, anything in that mystic quality called 'touch' on the pianoforte which could not be produced mechanically? This has recently been answered by some physicists in the University of Pennsylvania. The question they asked themselves was whether there is any peculiarity of quality which a Paderewski can produce from a given pianoforte which could not be produced from the same instrument by a learner or even by mechanical means. The question was answered in the negative after oscillograph records had been made of the notes produced by two American virtuosi and another set of records of the notes produced when a pendulum on release struck the same key. In every case it was possible to get an exact match of one of the human wave-forms with one of the robot's. In fact, the only factor which a player can vary is the speed with which the hammer hits the string. It is not possible to change the loudness of the sound without also changing its quality. This is the whole science of pianoforte playing.

Considerable attention has been given in recent years to the various commercial methods of producing music electrically. Some of these are modifications of existing instruments and are to be classed as electro-acoustical, while others are more completely electric and have no external similarity with

conventional musical instruments. In America the generic name of 'electronic' is given to them, though this is to be understood as implying no more than that valve amplifiers or oscillators appear somewhere in the equipment.

The least ambitious of these replace the sound-board of a conventional stringed instrument by pick-ups (one or more to each string) whose unmodulated electrical vibrations are amplified and delivered to a loud-speaker. Such is the Neo-Bechstein, a pianoforte without sound-board, and the electric guitar, which have pick-ups behind the strings. On all these instruments a magnetic pick-up may be used: that is to say, as the steel wire vibrates it changes the magnetic induction in a small coil nearby, or it may be an electrostatic principle, in which case the vibrator moves to and from a plate behind the wire. The wire is then charged to a difference of potential over the plate so that the pair make up a condenser of varying capacity which can be connected into the grid circuit of a valve amplifier.

The station of the pick-up along the wire influences the quality of the vibration passed on to the amplifier. Not only this, but the quality of the note of the wire itself exerts a powerful influence, and this in turn, according to well-known acoustical laws, is determined by the position and extent of the agent which sets the wire in vibration. Thus if the string is struck as in the pianoforte there will be a greater number of harmonics in the resulting tone if the hammer is sharply pointed and hard than if it is rounded and resilient. Furthermore, the choice of striking point operates in this way, that to each harmonic in the complex sound of the vibrating string there is a series of nodes and antinodes. If the location of the striking point is such that one or more of the harmonics require a node at that point, then these particular harmonics are absent in the resulting note. Similar principles apply to the situation of the pick-up. Electro-magnetic oscillations which it delivers to the amplifier will be deficient in those harmonics which have a node on the string opposite the pick-up while those with antinodes there will receive preferential

treatment. For this reason some inventors use a number of pick-ups to each wire and mix the resulting tones, though this is an expensive method and it is just as easy to modulate the tone from a single pick-up in any desired way.

Other instruments of the same type use reeds as the acoustic vibrators. Sometimes these are excited by hammers in the manner of a celeste (tuning-fork pianoforte); at other times wind-maintained reeds are employed as on the harmonium.

Next we may group those instruments which derive music directly from tuned circuits in oscillation and have no mechanical vibrators other than the diaphragm in the ultimate loudspeaker, if any. The prototype of these was the singing arc of Duddell. The arc was shunted by a coil and condenser whose inductance and capacity determined the natural frequency of the circuit. By continuously variable or step-by-step changes in inductance it was possible to play tunes on the arc. Since then numerous instruments using valve oscillators ('audions') have been patented, but those with keyboards and one oscillator to each note have proved too expensive both in first cost and upkeep of their numerous valves to gain a footing in the market. There remain the solo instruments of which the Theremin and the Trautonium have reached commercial production. Theremin's instrument, which was demonstrated in this country about ten years ago before a distinguished audience from the artistic world under the ægis of Mr. C. B. Cochran, is a beat frequency oscillator in which the capacity controlling the frequency consists of a copper loop and a baton held in the hand (or sometimes the hand itself). The beat note when the hand is away from the loop is above the audible limit but descends through the musical gamut as the hand approaches the loop in virtue of the increasing capacity, corresponding to the approach of an earthed conductor to an insulated plate in a familiar experiment of elementary physics. With this mode of control the music is confined to a series of single notes with a *glissando* between each which—together with the constant 'feeling' for the note, like a horn-player burbling for the harmonics of his instru-

ment—becomes rather distressing to the musical ear, in spite of the undoubted skill in performance of the inventor.

In the Trautonium, sponsored by the Telefunken Company of Germany, *portamento* playing is still possible, or one may proceed directly from note to note in proper musical style. A grid-glow tube is used as a variable frequency generator. The grid potential which determines the pitch is controlled by the length of resistance wire cut off by the player pressing some point on the wire on to a mark on a metal plate behind the wire, like the frets on a banjo. Another resistance under the plate is varied by the *pressure* of the finger on the plate and so alters the loudness of the sound. It is therefore possible to get as nice a variation in playing as a virtuoso may get from a violin by the mere gradation in the pressure of a single finger on the wire, including effects such as the vibrato and staccato playing. The Telharmonium of Cahill antedated the valve amplifier and loud-speaker. His apparatus, like those of the present day, produced electric currents of varying frequency and intensity from rotating elements. These currents were passed over the United States Telephone System and provided music for the household subscriber in a service very similar to that now available to subscribers in Great Britain to the service operated by the British Broadcasting Corporation in conjunction with the Post Office Telephone System. However, after the equipment had been set up the experiment had to be abandoned owing to interference and inductive effects on other lines in the far from perfect telephone system of those days (1900), though his system of production contained all the essentials of an electrical organ. There are now a number of these instruments to choose from, and at least three in Great Britain of which the Hammond (an American invention) is probably the most widely diffused.

A synchronous motor drives a series of ninety-one tone generators through gears and pinions. One of these is shown in Fig. 63. The tone-wheel is a polygonal plate about the size of half-a-crown rotating near a permanent magnet on which a coil is wound. As a high point on the wheel passes

the magnet it induces a pulse of current in the coil. The speeds of rotation and the number of corners on each wheel are so calculated that each disc produces one of the ninety-one partials used in building up the combination of fundamentals and harmonics to give the required timbre. The latter is assured in the harmonic controller wherein the various frequencies are superimposed and flow as a single complex electrical wave to the preamplifier located in the console. There is, of course, an intensity control for each

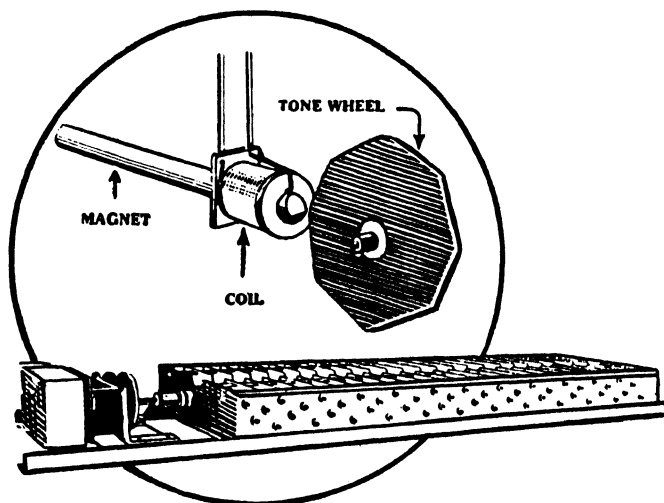

FIG. 63.—ELECTRICAL PRODUCTION OF TONE, ELECTRO-MAGNETIC TYPE (*Hammond*)

stop and a 'swell pedal' which alters the overall intensity between the preamplifier and the loud-speakers.

The other type uses electrostatic production of tone. This is the principle employed in the Compton and the Midgley electrophonic instruments. Two electrodes are spaced a small distance apart in the air, one moving relatively to the other. The two members constitute two plates of a condenser, usually at a fixed distance apart. An undulating variation in capacity between the members is caused by rotating one member, on which sinusoidal grooves are inscribed, while the other is kept fixed. As this system is liable to default due to buckling of one

of the plates or lack of parallelism, Midgley keeps both condenser plates fixed, while varying the dielectric constant. One of the stationary discs of insulating material to the face of which are fixed eight concentric rings of conducting material cut into sine waves is shown on the left of Fig. 64. The number of forms to each ring run in powers of two from the centre to the outer ring, which has 256 undulations. A pair of these stationary discs face each other, while between them another disc of bakelite rotates. The rotating disc is provided with

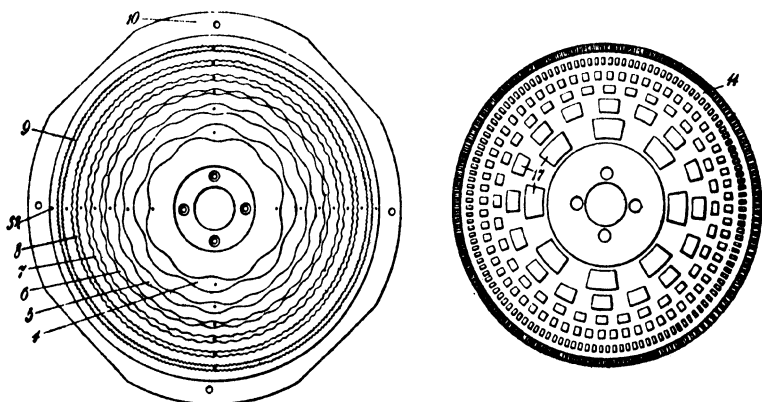

FIG. 64.—ELECTRICAL PRODUCTION OF TONE, ELECTROSTATIC TYPE (*Midgley*)

eight concentric rings of apertures each of which covers a half wave-length of the corresponding sine wave. These condensers of varying capacity are connected in the grid circuits of valves so as to produce the necessary fundamentals and overtones for covering the musical gamut.

On most of these instruments the control of timbre is assured by stops as on the classical organ, in some of which the timbre is preselected to give close imitations of common organ stops or orchestral instruments. Other combinations lie at the choice of the player. Thus on the Hammond organ there is a small manual of seven coloured keys at each end which determine the relative magnitude of the first seven harmonics of the fundamental of each note in the selective stops. Each of these control keys can be depressed through eight stages of intensity.

Thus in the combination 6, 0, 7, 0, 3, 3, in which the numbers denote the relative intensities of the partials on the harmonic scale, the predominance of the odd harmonics points to a clarinet tone. A similar combination with less of the fifth and sixth partials would imitate a stopped flue-pipe.

Although the three organs described normally give tones of fixed intensity, it is not difficult, though, of course, it adds to the elaboration, to introduce circuits which will damp the sound of each note from its inception and so mimic pianoforte, harp, or bell tone, but the artificial wave-form does not vary during attenuation in the same way that it does in some of these instruments. It is not beyond the wit of man to devise circuits which will change the quality at the same time as they make the note die away. Some inventors, indeed, derive both constant and evanescent tones as required from the same damped source, e.g. a struck reed. As soon as the sound has reached maximum intensity the pick-up is switched over to a circuit with a time constant which can be made to give long or short damping at will or to maintain the tone without dissipation as long as the key is held down, in spite of the damping in the acoustic vibrator (this necessitates a negative resistance in the circuit). On the Midgley organ low-pass filters for preventing the high-frequency oscillations produced by the key contacts from reaching the amplifiers produce a lag in both the rise and fall of intensity when the key is depressed and released respectively. The former gives a gratuitous imitation of the slowness of speech of certain organ pipes while the latter provides an artificial reverberation.

We have omitted from our classification those instruments which lie on the border between music producers and music reproducers or gramophones. There are, in fact, types in which the source is a sound film and light beam shining through the film on to a photo-electric cell, in exactly the same fashion as in the 'talking film.' The essential difference is that on the photo-electric organ the wave-forms on endless film comprise a series all having the same fundamental wave-length but differing in complexity. The fundamental pitch is varied by

the player altering the speed of rotation of the glass wheel on which the film is mounted, while the sideways shift of the beam of light alters the quality by bringing in a different trace. Such instruments become exceedingly complicated when adapted for playing more than one note at a time and are scarcely likely to find favour save where talking-film projector equipment is already installed. Even then it may be cheaper to purchase a library of sound-films for the music required than to employ a photo-electric organ and organist.

We have spoken so far of the electrical keyboard instrument as replacing the pianoforte and organ. This it can do quite well since it is the aim of the makers of such instruments to secure uniformity of quality throughout the pianoforte and through each stop of pipes or reeds on the organ. When one considers how far it is feasible to replace an orchestral instrument with an electric tone producer, another problem arises. One must consider what are the characteristic 'formants' of the instrument. A solo instrument of extensive range does not have the same wave-form throughout. That of the clarinet, for example, differs markedly in the upper register from the lower, while the timbre of the violin A played on the G string is not the same as that of the open A string. Each individual instrument has, in fact, characteristic resonances within its structure which reinforce certain partial tones in any note which is played and suppress others. No preset 'mixtures' such as the Hammond organ gives could give a satisfactory imitation of the clarinet or violoncello. To do this would necessitate the addition of elaborate filters having a fine structure of resonances to imitate the complex formants originating in the wooden air cavities of these instruments.

A refinement which Meissner applies to his instruments does not seem to have much point. It is well known that because of the incisive qualities of wind and percussion in the orchestra there is usually one man to each part in these departments, whereas string and voice parts are multiplied for the sake of balance. He claims that there is a distinct choral effect; that ten violins do not sound like ten times the sound of one. The

wave-form is certainly different, for even if all are in tune they will not be exactly in phase; but the ear cannot take cognisance of phase variations, while if the ten violins are not in tune, is this an 'effect' which ought to be incorporated on the electric organ? Similar remarks apply to the transient tones and starting noises which individualise many instruments. The quick speech of the flute, the slow drawl of the saxophone, the scrape of the violin bow before it bites the string, the *ictus* of the brass; all these are difficult to produce on an 'electronic' instrument, though essential if verisimilitude is the goal. But is it? While the inventor is eager to impress on the conservative musician that his product can do all that the older acoustic apparatus is capable of and in less space and at no more expense, the 'advanced' musician is willing to take the apparatus as it stands and either adapt existing music scores to it or write new ones. Already music has appeared for the electrophonic organ in which the timbre is expressed by the numbers corresponding to the requisite partial intensities instead of the stop registering on pipe organ scores. In fact it is a question whether some of the characteristics implicit in the music of some of the older instruments are not retained and tolerated because it is difficult to improve them within the framework of their present form and method of manufacture.

The same point arises in connection with fidelity of reproduction in broadcast music. Acoustic engineers will go into raptures over an amplifier and loud-speaker unit so perfect that the initial scraping of the violin comes out plainly even when they are playing ensemble. But is this really desirable? The point of view of the faithful reproducer becomes ludicrous when, as happened at a recent broadcast of a symphony concert under a corpulent conductor, the grunts of the maestro as he wielded his baton came through plainly in soft passages. This does not mean to say that virtuoso playing on a solo instrument will cease because of the limitations of the medium; there will always be pleasure to be derived from amateur music-making or watching the playing of an expert on a responsive string instrument even in these electro-mechanical days.

The Boat Race is not abandoned because the crews can now go more expeditiously from Mortlake to Putney by motor-boat!

The acoustics of the hall in which a concert is being performed must also be considered in relation to faithful reproduction. High frequencies are generally more rapidly damped in their passage through the air and on reflection at the walls of the room, so that a listener remote from the orchestra loses some of their energy. On the other hand, a position too close to the rostrum often leads to incorrect balance between the various instruments. With modern piezo-electric microphones and loud-speakers it is not difficult to reproduce frequencies up to 10,000 vibrations per second, so that the state of affairs is now being reached in which the concert-goer may hear a more faithful reproduction of the music as it comes from the orchestra if he stays at home in front of a good wireless set than if he books a seat in the concert-hall; though he still may feel disappointed in the radio version because it may not correspond to what he is used to hearing from his usual seat in the concert-hall.

#### SOURCES

- B. F. Meissner: "Electronic Music and Instruments" (Proc. Inst. Radio. Eng., **24**, 1427, 1936).  
 E. G. Richardson: "Wind Instruments in Scientific and Musical Aspects" (J. Roy. Soc. Arts, Cantor Lectures, 1929).  
 — "Acoustics of Orchestral Instruments," 1929.  
 — "Electrical Production and Analysis of Tone" (Proc. Musical Assoc., **66**, 1940).  
 T. C. Young: "Making of Orchestral Instruments," 1938.

#### JOURNALS

Musical Times; Musical Opinion; Proc. Musical Assoc.

## TEXTILE PHYSICS

It has been aptly said that the present time is as much the age of cellulose and rubber as the age of steel and concrete. It is only because we know that fabrics of some kind have been in use since the dawn of civilisation that we are inclined to forget the great strides which have been made in the manufacture of objects based on proteins, cellulose, and their derivatives in the twentieth century.

This is not a book of chemistry and we do not propose to discuss the molecular structure of the cellulose compound. We shall, willy nilly, have to connect up the observed physical properties of the raw materials with some account of what happens to their fundamental build-up when they are stretched, wetted, spun and treated to other elaborate manipulations before the fabric emerges from the loom. The common characteristic of all these substances which distinguishes them from many other commodities of commerce is that they are fibrous. Fibroin is a protein substance which is exuded by the silkworm and of which the molecules occur not as distinct units, as in water or common salt, but as organised groups of molecules (themselves elongated or needle-like) in the form of a long chain called a 'micelle.' It is the presence of these micelles all arranged with their heads and tails pointing in the same direction which gives to silk fibres an elongated or needle-like form, as opposed to the cubes of sugar crystals. These micelles are not peculiar to silk. They form the fundamental unit in wood fibre and so form the starting-point in the manufacture of rayon (artificial silk), as we shall see shortly. Cellulose is found again in the cotton plant, flax, jute and hemp and a number of other weaving materials. The special physical properties of wool and rubber we must leave until later.

Let us consider some of the outstanding physical properties of the silk fibre as typical of this group. The natural silk fibres have a diameter of about 20 microns, though their section is triangular rather than circular. We should expect silk to share with timber many of the specialities of that material, save that being single stranded instead of multi-fibred, it should be a more facile subject for physical research. When a load is applied to it, it stretches. If the extension is not more than two per cent. of its length, it recovers on removing the load. Beyond this elastic limit an increasing load causes a much greater stretching, but when the load is removed it only recovers a little and retains a permanent 'set.' In this behaviour it follows many naturally occurring substances both organic and inorganic. For its slimness the fibre has great tensile strength. A stress of several pounds per square millimetre is necessary to produce even the two per cent. extension corresponding to the elastic limit, while a stress of the order of 30 kilograms per square millimetre is required to break it. It behaves in a similar manner towards torsion. We ascribe this lack of recovery when the elastic limit is overstepped to internal slipping of the molecular chains over each other so that a permanent strain results. Did we say permanent? Not quite, for again imitating a metal, but to a much greater extent, textile fibres show a slow partial recovery after the load has been removed, even when strained well beyond the elastic limit. Evidently, in spite of the slipping of the micelle planes over each other, there remains a little elasticity in the new entanglement set up, whereby some of the forces relieve themselves after removal of the load, though, of course, the fibre does not get back to its initial size.

In view of the remarkable similarity between soil and timber in respect to the imbibing and losing of water in a moist atmosphere, the reader will now expect to be told that textile fibres partake of a similar lag in their wetting and drying-out, so that at a given humidity the water content is higher if the fibre is drying than if it is absorbing water; in fact, Fig. 32 which we drew in relation to clay will serve again for silk.

There are nevertheless some remarkable changes in the elasticities and strengths of fibres when moistened and when treated with alkalis and acids which are of great importance to the industry and to which we must now turn our attention.

When a textile fibre imbibes water it swells. Some of the water can be removed by centrifuging, but ordinary cotton will retain about 50 per cent. of its weight of water after removal of this excess. This 'fixed' water seems to be chemically held between the micelle chains, and as these are arranged roughly parallel to the axis of the cotton hair, the resulting increase in volume appears chiefly as a transverse swelling of the hair and a slight lengthening. In twisted fibres forming a hemp rope, there is an overall contraction when it gets wet—witness the tautening of a clothes line when left out in the rain—but this is because the lateral swelling of the fibres takes place at the expense of an increase in the diameter of the spiral which makes up the rope and a resulting retraction of the head of the rope in respect to the tail. The rope is actually strengthened by the water, probably because the structural elements swell and grip each other. The same is true of cotton yarn which is a twisted strand structure, but not of silk with its straight strands. Here the water acts as a lubricant making the silk easier to stretch, but lowering the ultimate breaking strength by some 15 per cent.

That cotton yarn has a twist in it is familiar to anyone who has tried to suspend a weight from the end of a cotton thread. The weight will go on rotating in one direction apparently without ceasing, whereas if hung on a strand of natural silk it will soon reach a position of equilibrium about which it will oscillate until brought to rest by frictional damping. The difference between the initial shape of the stress : strain curves of various fibres is to be accounted for in terms of the alignment of the micelles of the individual fibres along the axis. Fig. 65 (after Houwink) gives typical extension curves of various cellulose products.

Manifest changes in the structure of silk and cotton are introduced by the process named after its inventor: 'merceri-

sation.' The fibres are dipped in strong caustic alkali. That a chemical action takes place is shown by the liberation of heat when this is done; the fibre length contracts and frequently gains in strength. More important still, the fibre gains in lustre and takes the dye more readily, which is

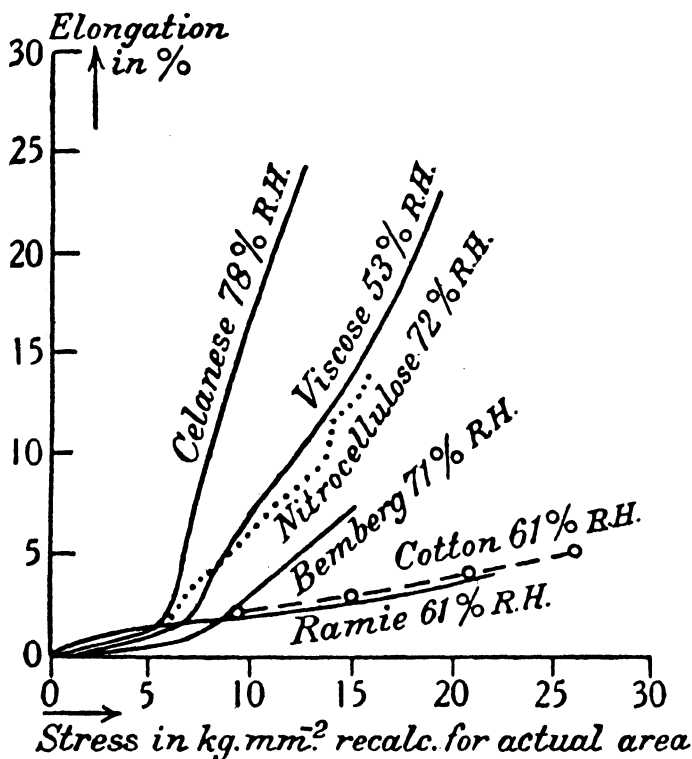

FIG. 65.—EXTENSION OF CELLULOSE TEXTILES AT VARIOUS RELATIVE HUMIDITIES (R.H.) (Howink)

the primary reason for its adoption. On the other hand, soaking the fibre in acid makes the fibre tender (as the textile worker calls it), that is to say, the strength is reduced, the stuff becomes less elastic and breaks at a stress from 40 to 50 per cent. lower than that of the untreated silk or cotton. We do not wish to enter into the vexed question of the chemical changes which accompany this treatment, but we shall have

something to say later about the changes in physical structure which underlie mercerisation.

Changes in both length and cross-sectional area (not always

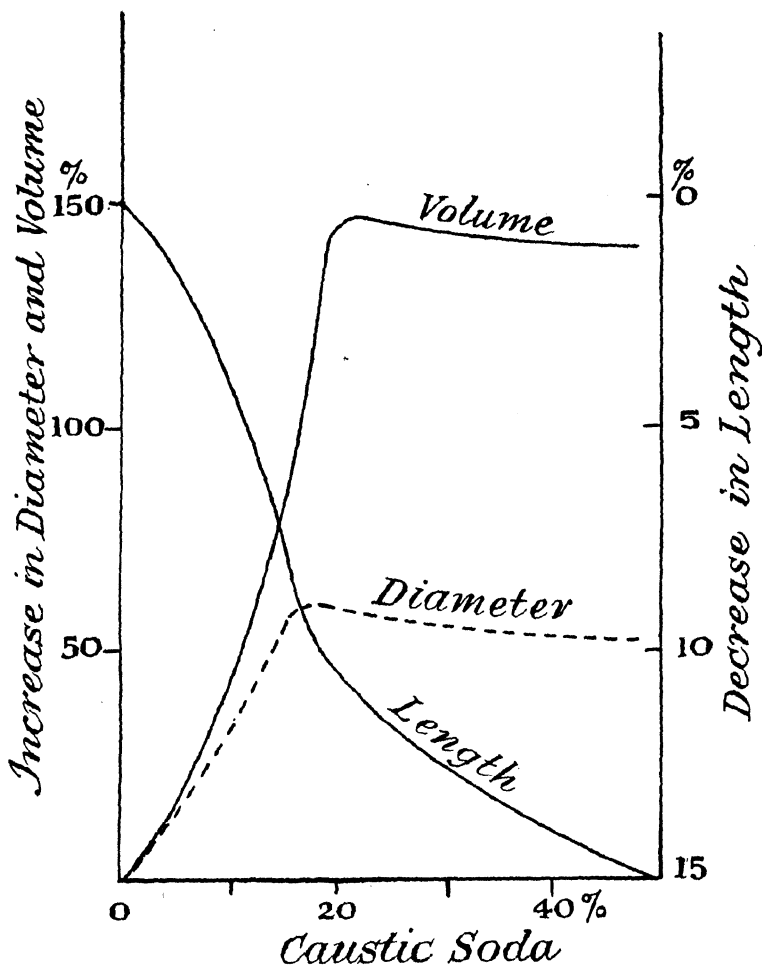

FIG. 66.—CHANGE OF DIMENSIONS OF COTTON FIBRE ON MERCERISATION (Collins and Williams)

self-compensating) occur during mercerisation. These are shown on Fig. 66 (after Collins and Williams). The change in diameter is measured by projecting an enlarged image of the fibre

when immersed in caustic soda on to a screen. In this case the mean diameter increases about five times as fast as the length decreases. It is also apparent from this figure that a concentration of 20 per cent. solution of caustic soda is sufficient to complete the swelling process. Under the microscope it can be observed that the section is no longer circular but often takes up a dumb-bell form as though cellulose were extruded by internal pressure from opposite sides of the section.

We must now pass on to rayon. The fundamental process in the rayon industry is the forcing of a solution of cellulose or one of its derivatives through a minute orifice, called the spinnerette, and the setting or solidification of the thread so spun. The possibility of imitating the action of the silkworm in a machine was suggested by Robert Hooke but first brought to a commercial process by the Comte de Chardonnet, about the beginning of the present century. In the Chardonnet process a solution of nitro-cellulose in alcohol and ether is squirted into water, when it immediately coagulates into the required thread, which is then wound on a spool. It will be noticed that in the coagulation part of the process the manufacturer does not copy the silkworm, which solidifies its thread by evaporation of the liquid which holds the silk in solution. In a variant of the process the cellulose is dissolved in a solution of copper hydroxide in ammonia called 'cuprammonium.' In both processes the thread is stretched as it coagulates to make it finer, again imitating the silkworm. Both these processes are expensive and—except for the best artificial silk—have been replaced by the viscose process. Viscose is a 7 per cent. solution of cellulose—the raw material being wood pulp—in a mixture of caustic soda and carbon disulphide. If it is left for some days, its viscosity gradually diminishes to rise again later. The change in viscosity is associated with a change in the mean particle size of the colloidal suspension of cellulose. When a suitable value of the viscosity is reached, the solution is spun into an acid solution of sodium sulphate to be solidified. A solution of cellulose

acetate in acetone produces 'celanese.' These and other special forms of rayon are noted on Fig. 65.

The differing stress-strain characteristic and tensile strength of cellulose derivatives is due to the relative length of the micelles and their orientation relative to the axis of the fibre. When the micelles are inclined to the axis, if, for instance, they form a closed spiral round it, the tensile strength is low, but the material is fairly elastic; pulling and twisting the fibre (within limits) merely orients them more or less along the axis, and when the stress is removed they can spring back into their old position. But if the micelles are well packed parallel and close together, all pointing along the axis, the application of stress can only make the micelles slide over each other, which, as we have remarked, is an irreversible process. The cohesion between the closely packed structures on the other hand is so great that it takes a great force to break it.

With rayon it is a little more complicated. Its behaviour suggests that while the outer skin of micelles is orientated the inner ones are not. When a piece of artificial silk is bent sharply over an edge the outer layers of micelles are partially deformed but the interior ones are not. So the material cannot recover and a crease remains on removal of the edge. A material in which conditions were reversed, namely, core orientated and sheath chaotic, would be nearly free from this defect. In fact, non-creasable ties can be made up from rayon thread which has been dipped in its matrix solution and allowed to dry. The great mechanical strength of some fibres is associated both with arrangement and length of the micelles. If these be broken down into smaller bodies, as they can be by the addition of acid, or lengthened by the addition of alkalis to the matrix solution, the resulting spun rayon is made weaker or stronger as the case may be. Since this decrease in particle size (in the colloidal suspension) is accompanied by a decrease in viscosity, a measurement of viscosity during the ripening of viscose (*vide supra*) is a necessary test to decide when the moment to spin has arrived. Fig. 67 shows the relation between the viscosity of the spinning solution and the

strength of the resulting rayon thread. It will be realised in the light of what we had to say on colloidal viscosity that these are the apparent values. In the textile trade it is usual to make these determinations by a capillary viscometer, which purports to give the viscosity from measurement of the rate of flow of the liquid through a tube of fine bore. Actually, with a

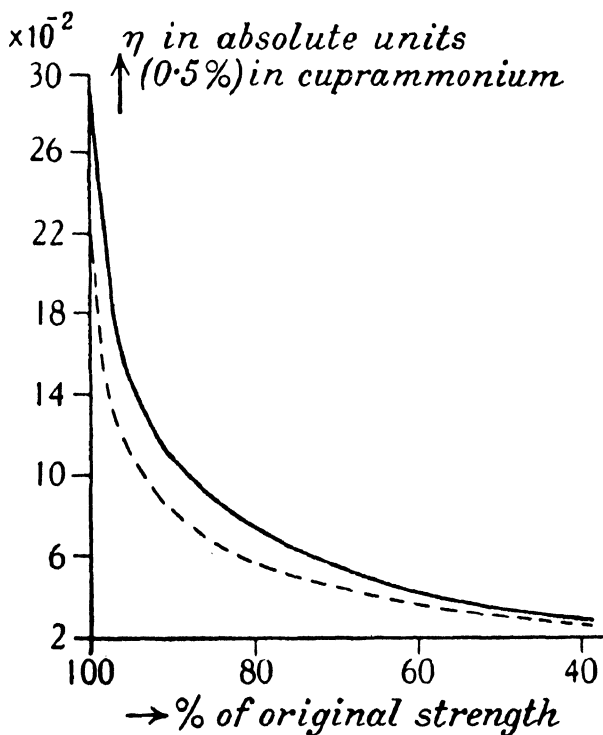

FIG. 67.—VISCOSITY ( $\eta$ ) and RELATIVE STRENGTH OF TWO VISCOSE SOLUTIONS (Howwink)

colloidal solution in the tube, such an apparatus cannot give absolute values; nevertheless, such measurements are useful for studying 'tendering.' Further confirmation of the view that elasticity and rupture in a textile are related to micelle orientation is to be obtained by so rolling out the fibres that the micelles are persuaded to take up positions parallel to the axis and close together. This is not easy to do with viscose,

but the material 'cellophane,' which is regenerated cellulose obtained in sheets by evaporation of the solvent, lends itself to the process of 'calendering' as it is called. The film is squeezed between rollers, which tends to set the micelles in the direction of rolling. If a strip be cut along this direction and loaded by a hanging weight, a larger stress is required to produce a given elongation or to rupture it than if a strip be cut parallel to the rollers. In one case the breaking stress 'along the grain' was four times what it was in a perpendicular direction. That some adjustment of the structure has occurred is shown by the test in which the optical properties of the 'cellophane' film are investigated. The calendered film is shown to polarise light along a plane which is related to the direction of rolling, whereas the original film showed no such preference. Sheet rubber behaves in the same way. Though humidity does not affect the tensile and elastic constants of cotton and natural silk very much (apart from the winding up of the spiral in cotton already noticed), wetting reduces the dry strength and extensibility of rayon to something less than that of natural silk. Silk will stretch more easily when wet, but rayon in this condition does not recover easily. Hence the advantage of using mixed thread in silk stockings. As long as they remain dry, the rayon will confer elasticity on the material and prevent the formation of 'ladders.' When exposed to the rain, it is the natural silk which must bear the brunt of any sudden stress and confer elasticity on the stocking. A ladder in a stocking in which pure silk predominates may be prevented from 'running' by wetting it, but the cure is only temporary until the portion dries again.

When we examine wool in respect to the same properties that we have been discussing for cotton and silk, we find many similarities but some small distinctions, which prove to be of great importance for deciding what the structure of the wool fibre may be like as well as accounting for the difference in behaviour of the textiles when woven into fabrics. The stress : strain curve for wool is generally S-shaped, particularly when the fibre is wet. A short, rather flat portion is shown

at the beginning in which the extension is proportional to the stress and the fibre recovers its original length when unloaded. Follows a steep rise over which the wool behaves as an easily stretched (ductile) body until a point of inflexion is reached in the curve, which now begins to bend over until rupture

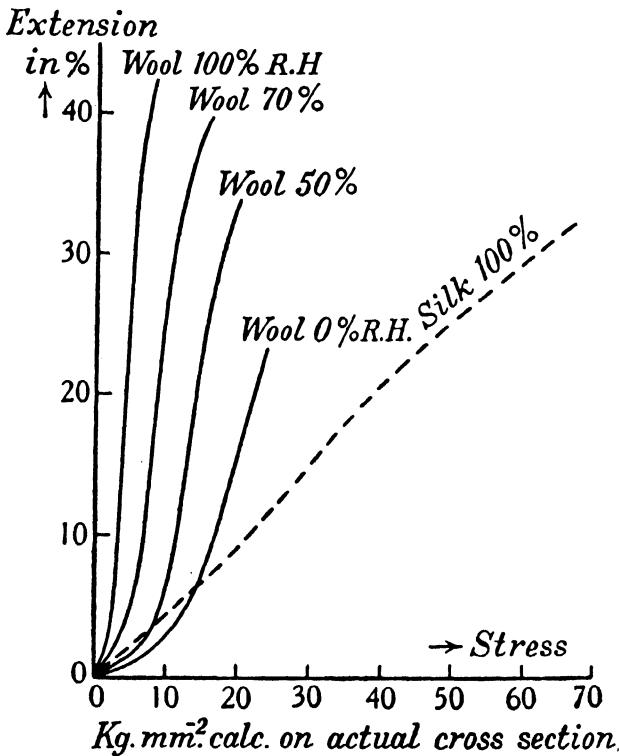

FIG. 68.—EXTENSION OF WOOL FIBRE AT VARIOUS RELATIVE HUMIDITIES (R.H.) COMPARED TO THAT OF SILK (*Howink*)

ensues. The steepness and worm-like shape of the curve becomes more pronounced as the humidity of the local atmosphere is raised (cf. Fig. 68). It is also apparent that for a given load the wool fibre is more easily stretched than silk. There is, in fact, a fundamental difference in the structure ascribed to these two fibres. In wool, the fibres in the unstretched material are supposed to be strongly crimped into

an undulating form which, if pictured in two dimensions, would look like the conventional wavy lines drawn by primitive artists and cartoonists to represent the sea. When the fibres are fully extended, the bundle would be (conventionally) represented as a series of straight parallel lines (like those they would use to represent still water) of the same total length as the wavy lines but, of course, occupying a much longer and narrower space than the first set, in virtue of the inevitable longitudinal extension and lateral contraction which follows an ironing-out process of this type. When rupture finally occurs, the extended molecule chains pull completely apart. If the wool is perfectly dry, it behaves when appreciably stretched as a plastic body, that is, it does not contract, apparently because cohesive forces between the molecules in the straightened-out position are sufficient to inhibit a spring back to the curly position. But when the fibre is moist, forces of attraction between the protein and the water molecules break down this cohesion, and the molecule chains relax a little towards their former position; at first rapidly, but then with decreasing speed until the fibre eventually 'sets' in a new length somewhat greater than the old. As the humidity increases so do both the ductility and the recovery on the removal of load. Finally, at one hundred per cent. humidity, there is sufficient water present to render the cohesive forces in the new position entirely unstable and the fibre returns completely to its initial length. This illuminates a fact about the industrial use of wool which must not be overlooked. If the fibre has been 'set' in a stretched position while dry or nearly dry, the first time it is completely soaked or left out in the rain it will shrink to the fully contracted size.

Fig. 68 tells us another thing of import to the textile worker. Dry wool cannot be stretched by more than one-quarter of its length without breaking, but in a saturated atmosphere with care and lack of haste, extensions up to two-thirds of the original length can be obtained without risk of breakage. For this and another reason the atmosphere of a mill must be moist and a watch kept on it, by means of automatic hygro-

meters. (The other reason is that textiles in the dry state can get highly charged with electricity by friction on the rollers, which are constantly apeing on a large scale the familiar experiment by which one may charge with electricity one's fountain pen by rubbing it in the hair, provided the scalp is dry.)

The peculiar S shape of the extension curve is no doubt due to the fact that attractions are at first upset easily (steep part), afterwards less readily, as the few remaining stubborn linkages are overcome (top of S). The crimps come out in spasms, not all together at the same rate. Another point in favour of conducting the weaving of wool in a wet atmosphere is that its torsional rigidity is many times reduced when wet. In some way the water acts as a lubricant and the yarn is then much easier to twist. If the temperature is raised at the same time as humidity is applied to the wool, for example, by placing the wool in the steam over boiling water, further interesting phenomena result. The fibre stretched under these conditions acquires a permanent set; or if fixed in any desired position in steam at 100° C. and held so for an hour it will retain that position—not, of course, with the complete rigidity of a bent wire. In physical and chemical properties the human hair differs little from that of the sheep. The implications of this experiment on the possibility of putting a permanent wave in human hair are obvious.

This same fact is made use of in shaping a hat on to a block. The crown is sewn up roughly to the shape required, but smaller than the block to which it is to be fitted. It is then stretched over the block after being wetted, and in this condition has a hot iron passed over it.

Under suitable applications of humidity and temperature stretched wool may acquire a length shorter than the one it had before any of these actions took place. For instance, if wool is held under tension in steam at 100° C. for less than half an hour and released while still in the steam, it retains a certain elasticity, so that the fibre recovers some of its extension. If the fibre is held stretched for only ten minutes, it will return

nearly to its original length in the steam, but if tensed for shorter periods than this it will contract to a shorter length than that from which it started.

Much of the peculiar behaviour of textiles under stress has been explained by X-ray studies of the fibre. In an earlier chapter we described how one could gain information about the sub-microscopic structure of a surface by the use of a beam of electrons. A microscope, whether it employs a light beam or an electron beam, can show us the pattern of a surface which is too fine to be distinguished with the naked eye.

If a beam of yellow light from a sodium lamp is passed through a clear atmosphere to fall on a screen, a clear well-marked light spot is, of course, seen on the screen. If now a fine mist is set up between the lamp and the screen, light is scattered by the liquid particles so that the spot becomes less bright and at the same time diffuse rings or haloes are seen to surround the central spot. (A similar effect, in which the screen is replaced by the retina of the eye, can be observed when the moon is looked at on a night on which there is a slight mist in the atmosphere.) The particles causing the diffraction in this case are naturally located in quite a haphazard fashion in the light beam. Now let us replace the mist by a more regular pattern, for instance, two sets of parallel lines ruled at right angles, like a miniature checker board. If the separation of the lines is not too great compared with the wave-length of the light, we shall see beside the central spot two series of yellow spots on the screen, one set parallel to each set of rulings and diminishing in intensity from the centre outwards, while the haloes will have disappeared—unless there is any dust or irregularity in the surface of the glass on which the lines are etched. The characteristic diffraction pattern of an unorientated medium through which the light passes is a set of diffuse circular zones; that of an orientated one a set of spots distributed round the central maximum in directions indicative of the lines of orientation and positions depending on the spacing. An intermediate stage would be characterised by more diffuse spots spreading towards each other and would

be represented in our model by having badly scratched and roughly ruled lines on the glass plate.

Now the same distinctions arise when we probe much deeper into the structure of matter and consider the arrangement of molecules within the crumbs. If this is higgledy-piggledy, the substance is amorphous, a powder; if, on the other hand, the molecules are arranged in definite groups and spacing, the substance on minute examination turns out to be crystalline. The difference between the pattern of the crystal and that of the ruled grating is that the former has three dimensions instead of two in its make up and the molecules producing the pattern are much closer together than any lines we could rule. For this reason we must use as our probing radiation something with a shorter wave-length than visible light, and we choose X-rays. In essentials the making of an X-ray diffraction pattern is exactly like that which we have described for light, save that a photographic plate replaces the screen. At first the investigators only expected to get the spots with a definitely crystalline substance like a crystal of Iceland spar or rock-salt placed in the X-ray beam, but many things have since shown a rudimentary crystal structure where it was least suspected, among them textile fibres.

It is evident that the X-rays form a valuable tool for the exploration of the inside of a textile fibre, both to find to what extent its molecules are orientated, and the size of the unit pattern (from the position of the spots) under various conditions. The work of Dr. Astbury at Leeds in the X-ray analysis of fibre structure has not only underlined the knowledge which we derive from chemical research in this subject but has brought out new features of the structure which were previously unknown. Thus the fact that in all fibres the molecular pattern is longer in the direction of the grain than across it is shown in the X-ray photographs not being completely symmetrical about the central spot, but having the spots longer in one direction than in one at right angles to this. The pictures are in fact symmetrical about one diameter. In some cases, however, the pattern is nearly circular, approxi-



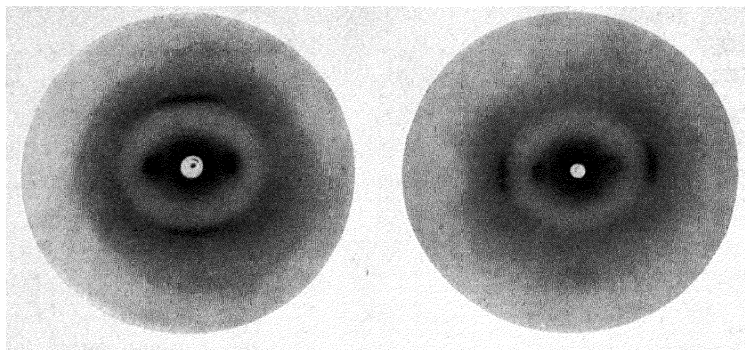

FIGS. 69, 70.—X-RAY PHOTOGRAPHS OF UNSTRETCHED AND STRETCHED WOOL. (*Astbury*)

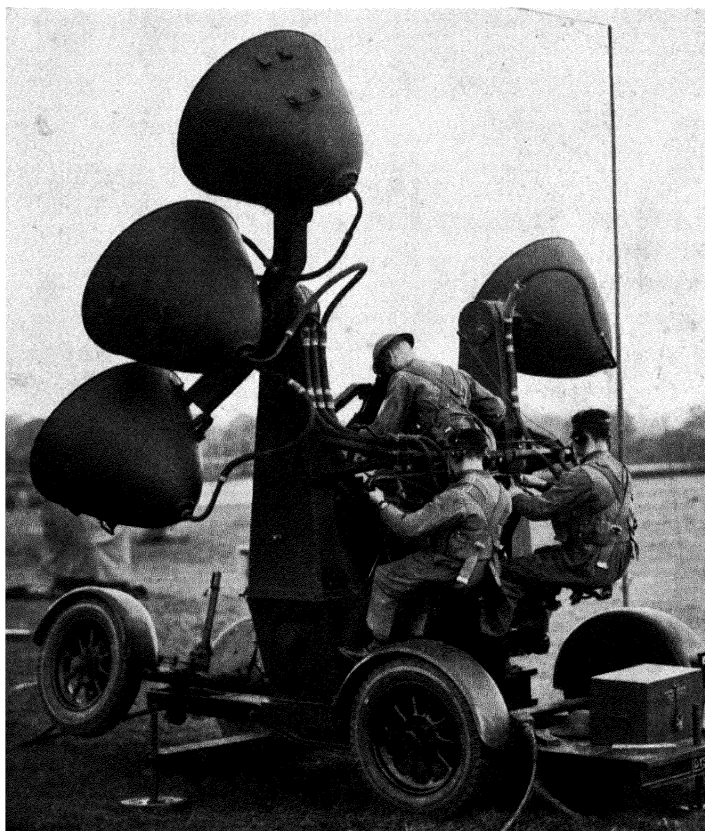

FIG. 73.—TRUMPET SOUND LOCATOR (*London News Agency*)

ming to the haloes that we get when light passes through a mist. This is so in the photographs for unstretched cotton. When the cotton is stretched and the micelles are drawn into line, a spotty photograph is produced. On measuring up the film the physicist is able to deduce that each unit in the cellulose chain occupies a space of  $3\frac{1}{2}$  Angstrom units.<sup>1</sup> It can be shown that the links in the natural silk are already in a well-extended position and further stretching can therefore only take place by the links sliding over each other in plastic deformation. An X-ray photograph in the latter state shows that no change has taken place in the links themselves beyond a slight straightening out, corresponding to the two per cent. elastic extension.

The normal X-ray photograph of wool dry or wet (Fig. 69, Plate VI) shows the typical symmetry of a fibre pattern. The crystals in the material must likewise be long and thin with their axes more or less parallel to the length of the fibre, but calculation indicates that the unit pattern is longer, 5 instead of  $3\frac{1}{2}$  units, than in silk. If, however, the wool fibre is stretched, this photograph is replaced by another (Fig. 70, Plate VI), in which the appearance of spots represents a more orientated arrangement which closely resembles that of silk. Removal of tension and moistening makes the picture revert to that of Fig. 69. Further, the crystalline unit pattern of wool in the extended form as deduced from the position of the spots on Fig. 70 proves to be  $3\frac{1}{2}$  Angstrom units, practically the same as that of silk. It is therefore concluded that, as we have already indicated, the molecular chains in the unstretched wool fibre are crimped (bent up like a rope ladder lying on the ground with the rungs over each other and nearly touching), and that stretching causes a reshuffling of molecule positions, so that the rungs in the straightened chain are closer together. Needless to say, this waviness is purely in the molecular structure in the fibre, it cannot be seen under a microscope like the twist in cotton thread.

Thus as far as structure goes stretched wool is like unstretched

<sup>1</sup> The Angstrom unit is one ten-thousandth of a micron.

silk—or stretched silk for that matter—but stretched wool is really an unstable form, and the chains tend to ‘curl up’ again unless inhibited by some molecule change. Such a change may be brought about by sufficiently prolonged application of water and heat. Again, X-ray studies of this permanent set show that some absorption of the water molecules has actually taken place, whereas the action of water on silk causes no change in the picture. Any water which gets into silk is squeezed in between the chains without altering the underlying molecular structure.

One of the physical properties with which the textile manufacturer is most concerned is that of colour and, particularly in the silk trade, with those features of the light reflected from the material which are usually understood by the terms lustre or gloss. With the measurement and classification of colour we have sufficiently dealt in a preceding chapter, but we deferred any discussion of lustre to this place as being more timely.

When light falls on a polished plate mirror or sheet of water it is regularly reflected, that is to say, the incident and reflected rays make equal angles with the surface, according to a well-known law. It is because of this that we can see clear images in such surfaces or that the sun shining on a cup of water produces a definite bright spot, the jack o’ lantern, on the wall or ceiling of a room. On the other hand, light falling on a roughened irregular surface like a carpet is scattered on reflection and does not form any clear image of objects in the room, though as much light falls on it as on the mirror. Intermediate stages are occasioned by irregularities in the mirror surface. If one breathes on the mirror, objects in the room are seen dimly as in a fog and the thicker the layer of condensed moisture gets the more obscure the picture becomes. If one ruffles the surface of the water in the cup, the jack o’ lantern becomes diffused and dim, though it is still evident that the reflected light favours some particular direction. The latter condition corresponds somewhat to the nature of several textile surfaces. A woollen stocking has no lustre, it scatters light equally in all directions, a silk or rayon one

should show a fairly bright but extended gloss; a line of reflected light following the contours of the leg to which it is shaped. At the other extreme a lacquered metal or varnished surface has a directive effect on the light approaching that of the best silvered mirror.

It is evident that the criterion of lustre is the relative amount of regularly reflected (or 'specular') and diffused light, and this is what the textile physicist sets out to determine. Lustre may be increased, as we have said, by alkalis, which probably give a more symmetrical shape to the fibre, or at the other end by the engraving of line patterns on the fabric where regular reflections are most likely to occur while the article is in use. This process (called 'schreiner'ing') is rather like that by which the engraving of a close series of lines on a piece of glass converts it into an optical grating, throwing the maxima of reflected light into certain directions. The twisting of cotton fibres in making up the yarn modifies the lustre, for this sets the threads at a definite angle to the axis, whose value determines whether the light is reflected more in one direction than another.

One method of comparing the lustre of yarns is to photograph them side by side through a wedge of liquid which absorbs the light to an increasing extent from one end of the yarn to the other. The yarns are illuminated uniformly and photographed by their reflected light. Then specimens which reflect most light in the direction at which the camera has been set will come out on the plate as being luminous for a long distance from the thin end towards the thick end of the wedge; conversely the lustreless ones will give a visible trace on the plate for a short distance only.

To get a quantitative measure of gloss a photometer is used. Light is shone on to the specimen in a beam from a definite angle—for instance,  $45^\circ$ —and an arm recording the reflected light is rotated about the front of it. The arm holds a photoelectric cell shielded from all rays other than those which are reflected from the fabric at the definite angle for which the cell is set to catch the radiation. With a highly glossy fabric,

naturally, the apparatus will record a large influx of light from the same angle on the other side of the normal, i.e.  $45^\circ$ , tailing off rapidly at larger and smaller angles. A dull surface records overall weakness in the reflected beam with perhaps little more at  $45^\circ$  than at any other angle. The lustre is then given a number which represents the relative values of the reflected light at  $45^\circ$  to the average at some larger or smaller angles (for example,  $60^\circ$  and  $30^\circ$ ) to which the angle of incidence is a mean. As an instance of the application of this apparatus, we may refer again to the doubling of cotton threads. At 12 twists per inch of a particular thread the lustre number was 35; at 8 or 16 it was 30, at 0 (straight) or 24 it was 20.

#### SOURCES

- W. T. Astbury: "Fundamentals of Fibre Structure," 1933.  
A. J. Hall: "Cotton Cellulose," 1924.  
R. Houwink: "Elasticity and Plasticity," 1938.  
R. Wheeler; "Artificial Silk," 1920.  
T. Woodhouse: "Artificial Silk Making," 1927.

#### JOURNALS

- Rep. of the Cotton, Silk and Wool Research Associations; J. Textile Inst.

## CHAPTER XV

### PHYSICS AND THE ART OF WAR

MANY problems are raised in the propulsion of projectiles, and in the 'art of war' generally. They embrace most of the branches of physics, setting apart the chemical aspects, but it is the subject of mechanics which is especially called on to supply answers to the majority of them. Indeed, the early treatises on mechanics in mediæval times devote quite a considerable space to this branch of applied physics, which we now know as ballistics. While it is neither desirable nor possible to publish details of processes employed in much of this work which are not, of course, committed to print, there is a certain amount of information which is the common property of all nations. A number of papers appeared in the years following the European War of 1914-18, in which some of the special information gained during its course by both sides was made public, and it is on these and certain standard handbooks on ballistics that this chapter is based.

In firing a gun, there is first the loading of the bullet or shell and its charge of powder in the breach; follows the starting of the ignition of the powder by an impulse or spark at one point and the development of pressure in the chamber; and finally the transfer of momentum from the products of combustion to the missile which is ejected from the muzzle.

The pressure which can be built up in the barrel by the chemical action involved in the combustion of the powder is naturally vital for the impulse transferred to the projectile. As momentum is measured in terms of the product of mass and velocity, in a gun of given calibre this maximum pressure will settle the range. In order to build up a good peak of pressure in the combustion chamber the initial ignition spark must spread rapidly throughout the charge and, to test this, measure-

ments of the velocity of this 'explosion wave' as it travels through the bulk of the powder are required. As unlimited supplies of powder are not available and as the wave travels with great speed, an apparatus is to be constructed to measure the short space of time that elapses between the passage of the wave past two stations set up a few feet apart in a long stick of the caked powder. In principle, the method does not differ from that by which the prisoner records the passage of the flame of combustion along a train of gunpowder laid along the floor to the keg of powder, in the 'thriller' of days gone by. At the two stations contacts are placed so that the passage of the explosive combustion passing over the first causes an electrical condenser, previously charged to a known potential, to lose its charge by the joining of its two plates across a high resistance. When the wave arrives at the second post, it operates another switch which incontinently stops the discharge of the condenser and sends the remnant of its charge through a ballistic galvanometer, where it is measured by the deflection of a coil or needle. Previously, the charge remaining on the condenser after it has been short-circuited through the resistance for given time intervals has been worked out. From the deflection of the galvanometer in the actual experiment, one calculates the charge which it has received and, hence, the time taken by the wave to pass between the two points. So its velocity is calculated.

The maximum pressure actually set up in the breach by the firing of a certain charge of powder is usually measured in an experimental bomb, constructed of strong steel walls able to resist fracture when the charge is fired. The pressure set up can relieve itself in one direction, for the walls are bored in one place to hold a moderately tight-fitting steel piston, which at its other end bears on a copper cylinder so centred that it receives the blow communicated by the steel piston axially and can expand or deform radially under the shock. After the powder is fired, the bomb is taken down and the deformation of the soft copper cylinder measured; from this the pressure communicated through the steel piston from the combustion

chamber is known from a previous calibration in which the copper cylinder was submitted to known impulses.

When it is desirable to have a record of the variation of pressure in the barrel with time and not merely of the total pressure impulse the best type of manometer is a piezo-electric one. A small crystal of quartz or tourmaline is located between two electrodes in the chamber, one electrode being part of the wall and the other a loose plate exposed to the gaseous pressure. As the latter varies, the pressure of the plate on the crystal changes, and the potential difference set up across the electrodes varies in sympathy, in accordance with the usual piezo-electric effect. This varying potential is, after amplification, taken to one pair of plates in the cathode-ray oscillograph, where its variation in respect of time may be followed by taking photographs, or—for visual observation—making use of the sweep circuit. This method is also an improvement on the rather rough-and-ready copper cylinder device in that its inertia is much less. This is shown by the records which reach higher values in the piezo-electric method, sometimes reaching the enormous value of three thousand times atmospheric pressure.

In former times, and still occasionally for guns of small calibre, the ballistic pendulum was used to measure the impulse which the bullet experienced. The latter was fired into a massive block of soft wood suspended so as to form the bob of a heavy pendulum. The impact caused the block to swing back and the principle of conservation of momentum shows that the extent of this sway-back is proportional to the velocity of the impinging bullet and its mass relative to that of the block. The bullet's velocity on striking the block, which is just outside the muzzle, is then calculated from the sway-back.

The ballistic balance being impracticable for modern projectiles, as well as being rather inaccurate, recourse is had to a means of measuring the muzzle velocity of the bullet from the time it takes to cover a measured distance shortly after its ejection from the gun. The shell may in succession break two wires through which it is fired and the time interval measured by a ballistic galvanometer in the way already

described for velocities of combustion. In place of the double wire system, two beams of light may be successively interrupted. To time the interval, the beams of light may be arranged to fall upon photo-electric cells and the interruption of the photo-electric currents made through glow relays to start and stop, respectively, a chronometer. The stations may be further apart than for the powder wave provided the bullet has not lost much speed in the interim and this makes the time a little longer and easier to record, though still of the order of hundredths of a second.

The bullet in its passage sets up aerial sound waves whose features we shall need to discuss in connection with 'sound ranging.' The delineation of these waves whose condensations of the air are sufficiently intense to alter the optical properties of the air along the wave front may be carried out by a procedure very like that which we described in relation to the propagation of sound waves in a model section of an auditorium (pp. 234-5). An intense electric spark is the illuminant of the sound field and is made to 'go off' at such an instant that it casts a shadow of the wave fronts on a photographic plate, placed parallel to but at one side of the trajectory. The bullet itself may be made to set off the light spark by breaking a wire in its passage (in which case the broken ends of the wire appear on the photograph) or, if this should lead to undesirable confusion of the picture, it may work a light relay when it passes in front of a photo-electric cell. A slight delay may occur before the light spark jumps its gap, but this may be allowed for by setting the trigger wire or beam of light a little in advance of the photographic plate and spark gap.

Unless care is taken in the selection of the resistances and condensers in the circuit containing the spark gap, the spark will be oscillatory instead of a single pulse, with the result of double or multiple exposures. The appropriate values of the resistance and capacity to make the discharge 'dead beat' are usually found by trial. The time of exposure may be made as short as one-millionth of a second, giving very clear-cut pictures.

Naturally, quite considerable pressures are set up by the firing of large cannon in the vicinity. These are measured by a baroscope, which is simply a reservoir of air closed on one side by a flexible diaphragm which receives the force of the wave of pressure and deflects inwards causing a momentary rise of pressure inside, which can be measured by the extent to which the diaphragm caves in, on the same principle as the aneroid barometer. The pressure is greatest about ten

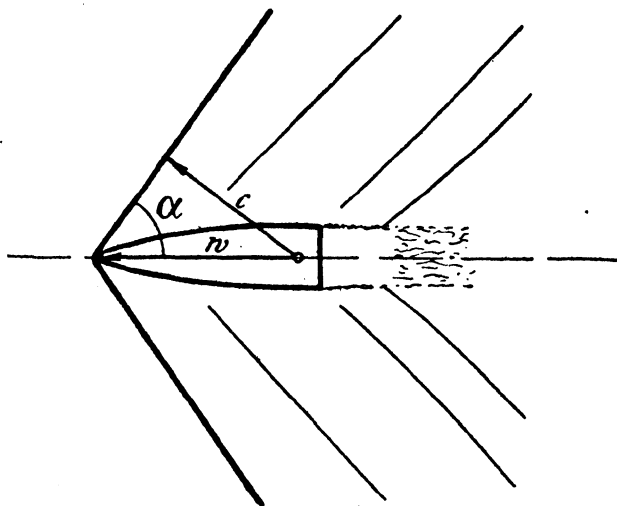

FIG. 71.—SHOCK WAVES FROM PROJECTILE AT SUPERSONIC SPEEDS

feet in front of the muzzle and falls from this point outwards in all directions. The pressure wave expanding from the muzzle takes the form of a cone with the muzzle as apex and the line of the projectile as axis. The first positive pressure impulse is intense and sufficient to crack a window pane, as well as produce painful effects on the ears of listeners, in its neighbourhood. It is, however, of short duration, less than one-fiftieth of a second. It is followed by a prolonged and slow recovery in the form of a negative pressure. This is attested by the fact that the fragments of broken glass from such a window fall outside the building as though sucked out by a return wave.

From the projectile there also speeds a wave system, which is clearly delineated in the spark photographs. As long as its speed is faster than that of sound, the bullet carries its sound with it. Listeners near its path will not hear anything until the projectile passes by, for the disturbance sent out as it cleaves the air is propagated with the speed of sound though its wave front is being developed all along its path. In consequence the spark photographs show a section of a conical wave front in the form of two straight lines, meeting at the nose of the bullet and inclined at an angle  $\alpha$  (Fig. 71) depending on the ratio of the velocities of bullet and sound respectively. This is because the cone is the locus of a series of ever widening and continuously created spheres which the bullet leaves behind it. Another cone of equal angle has its apex at the stern of the bullet where the air collapses into the cavity left by its path. This region is also a seat of turbulence which may often be descried upon the spark photographs. The conical waves have exactly the same origin as the bow wave, which may be seen as two straight lines of crests when a duck swims across a pond at a speed greater than the local speed for such ripples travelling on a water surface (cf. p. 33). When the bullet in deceleration falls in speed below the velocity of sound, or when the duck swims more slowly than the crests are propagated, the waves gain upon the moving object and arrive at an observation-post before the object itself.

In general, then, three sets of waves of low frequency arrive at an observation-post near a gun range: (1) this shock wave set up by the envelope of sound waves from the head of the projectile as it hurtles through the air at a speed exceeding that of sound; (2) the gun wave which left the muzzle when the gun was fired and travelled entirely at the local speed of sound to the post; (3) that of the fall or explosion of the projectile which travels at the speed of sound from another place. In addition, there is the high frequency swish of the turbulent wake left by the projectile in its path. The shock wave and the fall of the shell give rise to transient and nearly singular pulses, as is, in fact, indicated for the former by the clear sharp

wave in front of the spark photographs. On the other hand, the gun wave at this distance consists of several undulations of pressure at a low frequency, which indicates that they might be picked up in a vessel of fairly large capacity by the sympathetic response of the enclosed air; whereas the other two (and the high frequency hiss) would have little effect on it. Since a record of the time of arrival at a number of stations of the gun wave would lead to a ready prediction of the location

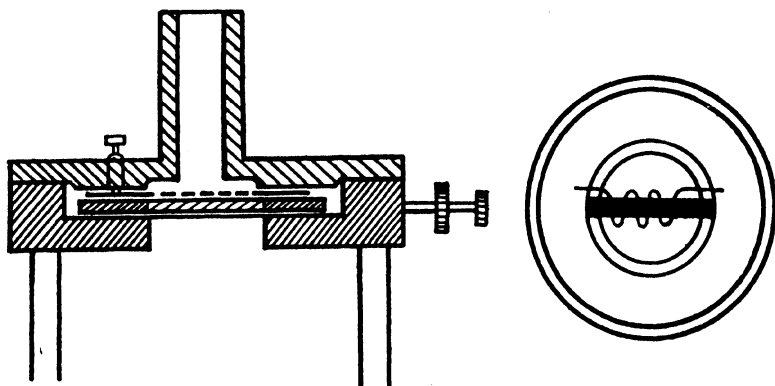

FIG. 72.—HOT-WIRE MICROPHONE (*Tucker and Paris*)

of an enemy gun on active service, apparatus of this type has been developed.

In the European War of 1914–18, the British used the hot-wire microphone of Tucker and Paris for this purpose. The object of this device is simply to indicate the amplitude of aerial motion in the opening of such a manometer, when it is responding to the slow periodic motion of the gun wave. The way in which a little grid, formed of platinum wire less than a thousandth of an inch in diameter, is clamped by a collar into the neck of such a resonator is shown in Fig. 72, where the lower part of the (closed) reservoir of air has been cut away. The grid itself is shown to the right of the same figure. It is wound in a number of loops about a former and the two ends brought to silver foil discs on either side of a mica disc, pierced by a central hole of the same diameter as the neck

of the manometer. Connection is thus assured to the two terminals shown.

In use the platinum wire is heated just below red heat by an electric current. It will be observed that the position of the grid is such as to protect it from casual draughts, at the same time to ensure that response of the manometer to the gun-fire in the form of undulations of the air in the neck will cause the wire to be cooled. The cooling results in a change of electrical resistance of the wire, and this is recorded on a suitable galvanometer, implemented with a drum camera to enable the instant at which the response occurred to be recorded.

The formation of wave fronts when the velocity of a projectile approaches or exceeds that of sound involves the expenditure of energy and so increases its resistance to motion. As far as the eddy-making resistance goes, experiment shows that the resistance coefficient, i.e. ratio of resistance to square of speed of translation, decreases somewhat at these speeds and the spark photographs show the reason why, which is that the turbulent wake becomes more restricted at high speeds. The net effect on the resistance depends on whether the decrease of eddy-making resistance is offset by the increase in wave-making resistance. Experimentally, one may determine the resistance of projectiles from their velocity at different points in their trajectories, or when they are held stationary in a wind tunnel capable of attaining speeds exceeding that of sound.

The bullet often acquires some spin in its flight, if indeed this is not purposely given to it before it leaves the muzzle by rifling the barrel in spiral grooves. This is done to stabilise the trajectory and to prevent wandering from the assigned path; a subject too abstruse to be dealt with without mathematics. That rotation has an effect on resistance cannot be gainsaid, though its precise rôle is not known. Another effect comes in if the shell spins about an axis inclined to its path, to wit, the Magnus effect, to which we referred in the third chapter, by which the projectile is deviated towards that side where the resultant velocity is greatest. This effect is well

known to persons who concern themselves with slower-moving projectiles such as golf and tennis balls.

When a rapid determination of the bearing of a source of sound is needed—either continuous or giving intermittent pulses—a listening instrument on the binaural principle is employed. Such an instrument, originally employed for locating hostile aeroplanes has received much attention in the past decade; other applications of this principle will be noted in what follows.

This principle is merely an application of the human faculty of determining the direction of a sound by listening with the two ears. The possibility of using this faculty, with instrumental aids for the spotting of the emplacement of guns, had been considered by the military towards the end of last century, although it was not until the aeroplane became a potential menace that full use was made of it. Indeed, the late Lord Rayleigh had in 1876 pondered the means by which binaural listening could inform a person of the direction of arrival of sounds at his head, and had separated out the two pertinent effects, viz. the intensity difference at the two ears and the phase difference. He decided that in the lower-frequency range the phase difference must be the discriminating factor. Indeed, when one reflects that the head can only form a considerable shadow over the further ear to sounds which have the half wave-length equal to the diameter of the head, one concludes that it will be only above 800 vibrations per second that the intensity difference can make a notable contribution to the detection of direction. Actually, though the sounds made by an aeroplane have a multiple origin, propeller noises, aeolian tones of struts, exhaust puffs, etc., the important region for listening purposes lies between 300 and 600 vibrations per second. When an electrical circuit intervenes between the artificial ears and the human ones, the rest of the noise spectrum is generally removed in a band-pass filter. The ways in which the detecting apparatus improves on the unaided ears are twofold: (1) trumpets or mirrors collect the sound over a wider area than the human ear and concentrate it on to the

throat or focus of the apparatus as the case may be; (2) the collectors are spaced at a greater distance apart (usually about 12 ft.). The object of the former is obvious. The latter increases the sensitivity of direction fixing. The auditory resolving power is a function of the least time difference between arrival of compressions which the ears can detect. The actual sensitivity can then be increased in proportion to (a) the wavelength of the sound, (b) the separation of the artificial ears. In practice there are four of these arranged in T fashion. The whole apparatus is pivoted on a universal joint at the junction of the arms of the tee. The two collectors at the ends of the horizontal arm serve to determine the bearing on a horizontal projection, and are under the control of one observer. The other finds the elevation, having the trumpets at the end of the upright connected severally to his ears. When they have finished spotting, the plane of the tee framework should lie at right angles to a line joining the apparatus to the sound source, in the absence of refraction *en route*. The observers naturally need training in the use of the binaural faculty, and in working the apparatus without interfering with each other's movements, but with practice, it is said to be possible to detect within 0.1 degree with the British pattern apparatus. At night the movement of a searchlight beam is often co-ordinated with the direction finder. Of course it is important that unwanted noises shall not penetrate the collectors. The sounds set up when the apparatus is exposed to the wind are troublesome, especially æolian tones of supports, and edge tones formed in the trumpets which may excite the air cavities into resonant vibration (cf. the sounds heard in holding a sea-shell to the ear); but these can be minimised by padding the sharp edges of the trumpet frames so that the adventitious noises do not mask the distant source which it is required to detect. The second type of direction finder does not use the binaural faculty. All that it asks of the ear is to judge the loudest of a set of sounds presented in turn to it, and this operation can be performed instrumentally, if it is desired to make the whole operation objective. A single large reflector several metres across

collects the sound and delivers it to a set of some thirty electro-dynamic microphone units disposed about the focal plane. These must be nicely matched in characteristics. Most of the sound energy in a parallel beam incident upon the mirror will then be concentrated in one or two of the pick-ups. Actually the focal plane in the type of mirror employed is a sphere. In the compensator which measures the intensity of the current from each microphone, contacts are similarly disposed about a smaller sphere over which the operator passes a switch to pick out the maximum response; the azimuth of the corresponding contact can then be seen on the sphere. The apparatus, though less mobile than the first type, has this advantage, that the recording instruments can be at a distance from the mirror and in a more protected site. For submarine direction-finding under the sea, it is the only serviceable type, the binaural detector being too subject to casual sounds. In the naval type the microphones are disposed only in a horizontal plane, on half-ellipses, one each side of the vessel which is picking up the noise. The bearing of the source of sound can then be read off directly on a dial in the instrument room.

Optics, too, has important work to do for a fighting force. One need scarcely emphasise the great strides which have been made in the world of the camera and the telescope in the past decade. Prismatic sights for guns and aeroplanes have been improved both in range and accuracy. Whereas a few years ago an anti-aircraft gunner had to guess at the point in advance of a moving aeroplane at which he ought to direct his aim in order that target and projectile should arrive at the same point in the sky at the same time, there is now an apparatus which predicts the correct aim and time for him, based on a system of optical projection of preceding positions of the quarry in flight, provided that the course and speed remain substantially unchanged in the interim.

It is easy to speculate on the use that electro-magnetic radiation might be put to in time of war. One constantly hears of inventions of 'death rays' which eventually turn out to be nothing more lethal than a means of stalling an internal com-

bustion engine by upsetting the regulation of the firing spark and whose range of action is usually an absurdly small one. Others propose clouds of electrified air particles or falling sand which would, they hope, form an invisible barrage in which the electrical equipment of aircraft would be put out of action. Most of these schemes are halting while their inventors bridge the gap between the small-scale laboratory experiment and the application of the ideas to actual warfare and to the 'infection' of large volumes of the atmosphere. This being so, we shall not pursue the subject further, since we have made it our province in this book to describe what has been rather than what might be accomplished in the realms of applied physics.

#### SOURCES

- F. Bashforth: "Ballistic Experiments," 1908.  
J. H. Ingalls: "Interior Ballistics," 1912.  
D. C. Miller: "Sound Waves and their Uses," 1937.  
E. T. Paris: "Binaural Sound Location" (Science Progress, **27**, 437, 1932).  
E. G. Richardson: "Applications of Sound" (Science Progress, **32**, 254, 1928).  
R. S. Tucker: "Sound Reception" (J. Roy. Aero. Soc., **28**, 504, 1924).

# INDEX

- Absorption coefficient to sound, 211, 230  
Acoustic impedance, 80, 247  
    " materials, 215, 217  
Acoustics of buildings, 229, 260  
Aeration, 116, 127, 139  
Aerofoil, 8, 21, 44, 56  
Aeroplane, 44  
Air-conditioning, 236  
Archæology, 197  
Artificial lines, 71  
Atmospheric railway, 9  
Auto-gyro, 61
- Baking, 100, 110  
Ballistics, 279, 281, 289  
Banking on curves, 13  
Bicycle, 1, 7  
Boundary layer, 55, 58, 150  
Bow wave, 33, 284
- Cable trunk, 70, 82  
Celanese, 267  
Cellophane, 269  
Cellulose, 263, 267  
Centrifuge, 90, 173  
Ceramics, 85, 99  
Cereals, 104  
Check dams, 147, 163  
Chocolate, 116  
Clay, 86, 96, 109, 113, 127  
Coagulation, 111, 185  
Colloids, 86, 96, 117, 121, 125, 130, 159, 183  
Colour testing, 66, 187, 276  
Combination tones, 82, 83  
Compressed air tunnel, 47, 53  
Compressibility, 106, 115  
Conservation of soil, 160, 162  
Cotton, 263  
Cream, 115  
Critical speed, 33, 51  
    " stress, 94, 99, 203
- Decibel, 28, 75  
Diffraction, 41, 214  
Diffusion, 139, 152  
Direction finding, 36, 175, 287  
Dough, 104, 109  
Dust detection, 172, 174  
Dynamometer, 17, 53, 128
- Echo prospecting, 176, 197  
    " sounding, 35, 37  
Elasticity, 106, 108, 110, 118, 196, 203, 262, 267, 270  
Electrical production of tone, 252  
    " resistance applications (see also hot-wire anemometer), 172, 181, 209  
Electrification of soil, 131, 142  
Electron microscope, 184, 186  
Emulsion, 111  
Erosion, 146, 148, 150, 164  
Extension, 106, 203  
Extrusion, 106, 109, 195
- Fibre saturation, 206  
Filter for radiation, 72, 171, 258, 288  
Fish pass, 146  
Flapping flight, 63  
Flood lighting, 226  
Flour, 104  
Fluidity and flow phenomena, 93, 116, 118, 122, 127, 186, 195  
Focusing of radiation, 225, 233  
Force balance, 47  
Forced vibration and resonance, 26, 73, 216, 241, 249  
Formant, 258  
Friction, 2, 5, 129, 145  
Froth, 116
- Gas detection, 171  
Gearing, 7  
Gelation, 105, 117, 122, 130, 185  
Geophone, 174, 197  
Glare, 222, 227  
Glaze, 85, 100, 187  
Gravity balance, 178  
Gunfire, 280, 283
- Heat insulation, 101, 219  
Honey, 108, 116  
Hot-wire anemometer, 55, 96, 121, 153, 285  
Humidity, 136, 139, 207, 236, 239, 264, 271
- Illumination, 223  
Impedance, acoustic, 81, 216, 247  
Infra-red applications, 190
- Jet propeller, 10, 23

- Katzmayer effect, 63  
 Kearney tube, 9  
 Kiln firing, 100, 208  
  
 Lift/drag ratio, 8, 48, 63  
 Locomotive, 18  
 Loudness scale, 28, 75, 229  
 Lustre, 264, 276  
  
 Magnetic surveying, 180  
 Magnus effect, 22, 60, 150, 286  
 Masking test, 79  
 Meander, 148  
 Mechanical analysis, 86, 126, 153, 156, 173, 199  
 Mercerisation, 264, 277  
 Micelle, 261, 267  
 Microphone applications, 35, 74, 212, 219, 284, 289  
 Microphotography, 192, 200  
 Minimum audibility, 28, 80, 232  
 Mining warning devices, 168  
 Model research, 34, 44, 51, 53, 148  
 Moisture content, 133, 161, 207, 209, 271  
 Mono-rail, 9  
 Motor car, 10  
 Moulding, 99, 102, 193  
  
 Navigation, 35  
 Noise insulation, 25, 27, 80, 210  
   " measurement, 28, 79  
  
 Organ, 234, 242, 254  
  
 Paint, 183, 190  
 Paper, 190  
 Particle size, 86, 99, 104, 126, 130, 173, 184, 199  
 Phon, 28, 75  
 Photo-electric applications, 87, 153, 158, 165, 168, 189, 206, 223, 257, 277, 282  
 Photo-electric relay, 167, 170  
 Photometer, 223, 277  
 Pianoforte, 251, 257  
 Picture examination, 190  
 Piezo-electric applications, 42, 83, 102, 112, 281  
 Pigments, 183, 191  
 Pitot tube, 53, 237  
 Plasticity, 93, 105, 186, 193  
 Plastics, 193  
 Ploughing, 127, 130, 164  
 Pneumatic tyre, 2  
 Pore space, 132, 138, 150, 203  
 Precipitation of dust, 172, 240  
  
 Railroad, 5  
 Railways, 7, 16, 65  
  
 Rayon, 266  
 Refractory materials, 101  
 Relaxation of materials, 108, 110, 118  
   " oscillations, 27  
 Resistance, hydrodynamic, 8, 18, 21, 33, 50, 131, 236, 286  
 Resonance, 26, 73, 216, 249  
 Reverberation, 214, 229, 257  
 Reynolds' Number, 51, 58, 149, 152  
 Rigidity, 95, 99, 119, 122, 186  
 Road making, 1, 12  
 Rocket car, 11  
 Rotor craft, 22, 60  
 Rowing, 21  
  
 Safety glass, 196  
 Sailing, 21  
 Saltation zone, 151, 155  
 Schreinerling, 277  
 Screw propeller, 10, 23  
 Sedimentation, 86, 105, 126, 173, 185  
 Seismograph, 177  
 Shock wave, 284  
 Signalling, 35, 65  
 Silage, 143  
 Silk, 262, 276  
 Silt, 127, 150, 155, 159, 165  
 Singing propeller, 25  
 Slotted aerofoil, 50  
 Smoke detection, 170  
 Soil, 85, 125 *et seq.*, 174  
 Sol, 117  
 Sound absorption, 30, 123, 211, 230  
   " laboratory, 213, 216  
   " ranging, 287  
 Sound-board, 234, 249  
 Sounding of materials, 100, 197, 248  
 Spark photography, 235, 282  
 Speech sounds, 71, 73  
 Standing waves, 33, 211, 215  
 Streamlining, 18, 32, 50  
 Stringed instruments, 248  
 Supersonics, 41, 83, 102, 112, 116, 122  
  
 Telegraph, 67, 71  
 Telephone, 68, 73, 82  
 Tensile strength, 108, 205, 267  
 Terracing, 163, 199  
 Thixotropy, 130, 185  
 Tidal models, 149  
 Tilth, 125, 141  
 Timber, 202, 219  
 Tintometer, 67, 187  
 Toffee making, 108  
 Transmission of sound, 212, 219  
 Turbidity, 157  
 Turbulence, 18, 51, 57, 152, 284  
  
 Ultrasonics, 41, 83, 102, 112, 116, 122  
 Ultra-violet applications, 189

- Velocity gradients in flow, 96, 121, 150, 155  
Ventilation, 238  
Vibration of aeroplane wings, 63  
    " propellers, 25  
    " ships, 32  
    " trains, 16  
Viscosity, 51, 93, 110, 112, 115, 117, 123, 127, 133, 186, 268  
Vortices in wake, 26, 284  
  
Warble tone, 214, 232  
Warning devices, 168  
Water and soil relationships, 131, 138, 160  
Water and textile relationships, 263, 271  
Water and wood relationships, 206, 262  
Water-channel, 154  
Wave formation, 33, 165, 174, 282, 284  
Wind instruments, 242  
Wind-tunnel, 45, 53, 208  
Wood, 202, 218  
Wool, 269  
  
X-ray applications, 190, 193, 251, 275  
Yield tests, 196, 262















