

TIGHT BINDING BOOK
DRENCHED BOOK

UNIVERSAL
LIBRARY

OU_162259

UNIVERSAL
LIBRARY

UP-881-5-8-74-15.000

OSMANIA UNIVERSITY LIBRARY

Call No. **536**

Accession No. **3052**

Author **585T**

title

Book should be returned on or before the date last marked below

Science Text-Books.

SCIENCE GERMAN COURSE. By C. W. PAGET MOFFATT,
M.A., M.B., B.C. *Second Edition.* 3s. 6d.

SCIENCE FRENCH COURSE. By C. W. PAGET MOFFATT,
M.A., M.B., B.C. 3s. 6d.

THE TUTORIAL CHEMISTRY. By G. H. BAILEY, D.Sc., Ph.D.
Edited by Wm. BRIGGS, LL.D., M.A., B.Sc., F.C.S.
Part I. NON-METALS. *Fourth Edition.* 3s. 6d.
Part II. METALS AND PHYSICAL CHEMISTRY. *Third
Edition.* 4s. 6d.

ELEMENTS OF ORGANIC CHEMISTRY. By E. I. LEWIS,
B.A., B.Sc. 2s. 6d.

QUALITATIVE DETERMINATION OF ORGANIC COM-
POUNDS. By J. W. SHEPHERD, B.Sc. 6s. 6d.

TECHNICAL ELECTRICITY. By H. T. DAVIDGE, B.Sc., and
R. W. HUTCHINSON, M.Sc. *Third Edition.* 5s. 6d.

MATHEMATICAL PHYSICS, ELECTRICITY AND MAG-
NETISM. By C. W. C. BARLOW, M.A., B.Sc. 4s. 6d.

ADVANCED TEXT-BOOK OF MAGNETISM AND ELECTRI-
CITY. By R. W. HUTCHINSON, M.Sc., A.M.I.E.E. Two Vols.
8s. 6d.

PROPERTIES OF MATTER. By C. J. L. WAGSTAFF, M.A.
Third Edition 3s. 6d.

QUANTITATIVE ANALYSIS, ELEMENTARY. By Wm.
BRIGGS, LL.D., M.A., B.Sc., and H. W. BAUSER, M.A. 2s.

BOTANY, TEXT-BOOK OF. By J. M. LOWSON, M.A. B.Sc.,
F.L.S. *Fifth Edition.* 6s. 6d.

ZOOLOGY, TEXT-BOOK OF. By H. G. WELLS, B.Sc.,
and A. M. DAVIES, D.Sc. *Sixth Edition.* Revised by J. T.
CUNNINGHAM, M.A. 6s. 6d.

LONDON: W. B. CLIVE, HIGH ST., NEW OXFORD ST., W.C.

A
TEXT-BOOK OF HEAT

THEORETICAL AND PRACTICAL

BY

R. WALLACE STEWART, D.Sc.

AUTHOR OF "A TEXT-BOOK OF LIGHT," "THE HIGHER TEXT-BOOK OF MAGNETISM
AND ELECTRICITY," ETC.

AND

JOHN SATTERLY, D.Sc., M.A.

ASSISTANT PROFESSOR OF PHYSICS AT THE UNIVERSITY OF TORONTO,
JOINT AUTHOR OF "MATRICULATION MAGNETISM AND ELECTRICITY,"
"PRACTICAL PHYSICS," ETC.

Third Impression



LONDON: W. B. CLIVE

University Tutorial Press Ltd.

HIGH ST., NEW OXFORD ST., W.C.

1917

PREFACE.

THE object of this book is to provide a course on the theory of Heat, of Intermediate University standard, linked up more closely than is usual with the practical side of the work. Accordingly a large number of experiments is included, specially suited for laboratory practice; and where possible the text is based upon them. Also where classical experiments are described they are frequently illustrated by simpler experiments which are well within the students' powers.

Considerable trouble has been expended to insure the inclusion of the most recent methods of work and the description of the most suitable forms of apparatus.

Full accounts have been given of the latest methods in pyrometry, the liquefaction of gases, and the determination of vapour density and of temperature gradient, while the graphical treatment of expansion and conduction of heat deserves mention.

This book is based upon text-books on the subject written by the late Dr. R. Wallace Stewart, but with that exception Dr. John Satterly is solely responsible for its contents and methods of treatment.

CONTENTS.

	PAGE
CHAPTER I. - INTRODUCTORY	1
CHAPTER II. - THE THERMOMETER	9
CHAPTER III. - APPROXIMATIONS	32
CHAPTER IV. - EXPANSION OF SOLIDS	38
CHAPTER V. - EXPANSION OF LIQUIDS	65
CHAPTER VI. - EXPANSION OF GASES	95
CHAPTER VII. - CONVECTION	129
CHAPTER VIII. - CALORIMETRY. SPECIFIC HEAT	143
CHAPTER IX. - THE LOWER CHANGE OF STATE	171
CHAPTER X. - PROPERTIES OF VAPOUR	200
CHAPTER XI. - THE HIGHER CHANGE OF STATE	224
CHAPTER XII. - HYGROMETRY. METEOROLOGY	268
CHAPTER XIII. - CONDUCTION OF HEAT	293
CHAPTER XIV. - RADIATION	322
CHAPTER XV. - FORCE. WORK, POWER, ENERGY	362
CHAPTER XVI. - MECHANICAL EQUIVALENT OF HEAT	378
CHAPTER XVII. - ISOTHERMALS AND ADIABATICS	405
CHAPTER XVIII. - THERMOMETRY AND PYROMETRY	444
CHAPTER XIX. - LIQUEFACTION OF GASES	461
ANSWERS	470
INDEX	475
EXAMINATION QUESTIONS	139, 198, 200, 360, 459
TABLES (<i>see Index under "Tables"</i>).	

HEAT.

CHAPTER I.

INTRODUCTORY.

1. **Heat sensations.** We distinguish in every-day life between "hot" and "cold" bodies by the sense of touch, and we are familiar, in the same way, with the fact that one body may be "hotter" or "colder" than another, or that the same body may become "hotter" or "colder."

When we touch a substance hotter than the hand we experience the sensation of heat, and we say that heat ~~passes~~ ^{flows} from the substance to the hand. In the same way when we touch a substance colder than the hand we experience the sensation of cold, and we say that heat passes from the hand to the substance. In each case the intensity of the sensation depends upon the extent to which transfer of heat between the hand and the substance takes place, and, as will be learnt later, this depends not only upon how hot or cold the substance is, but also upon the nature of the substance.

It must be noted, however, that sensation is not always a safe guide in determining the relative hotness or coldness of bodies. For example, let the right hand be placed in hot water and the left in cold water for a minute or so, and then let both hands be plunged simultaneously into luke-warm water. This water will feel hot to the left hand and cold to the right hand. This shows that in interpreting sensations of heat and cold the previous state of the hand, or other organ of touch, must be considered.

Again, in the hot room of a Turkish bath all the objects are equally hot and hotter than the body. To the sense

of touch, however, all objects made of good conducting material, such as metal, appear to be much hotter than objects made of bad conducting material, such as wood or cloth. This, as explained later, is due to the fact that in the case of good conducting materials the transfer of heat to the hand is greater and more rapid than in the case of bad conducting materials. Similarly, on a cold day an iron bar lying out of doors will appear much colder than a broomstick, owing to the fact that heat is transferred more rapidly from the hand to the iron, which is a good conductor, than to the wood, which is a bad conductor. These illustrations show that in interpreting sensations of heat and cold the nature of the substance touched must be considered as well as the state of the organ of touch.

It should be noted that the sensations referred to in this article are those due to actual contact with a hot or cold body.

The sensations of heat and cold experienced in the neighbourhood of hot and cold bodies are usually due to radiation. This subject is dealt with in Chapter XIV.

2. Temperature. Instead of saying that a body becomes hotter or colder we may say that a body acquires higher or lower degrees of hotness. Degrees of hotness below a certain standard, commonly that of the human body, might perhaps be spoken of as degrees of coldness, but it is more convenient to use one term—hotness—as applicable throughout the whole range of temperature. To speak of degrees of hotness is, however, clumsy and inconvenient. The term temperature is therefore used when we deal with the idea of degree in relation to hotness.) When a body has acquired any particular degree of hotness it is said to be at a particular temperature, and as a body becomes hotter its temperature is said to rise, and as it cools its temperature is said to fall.

3. Difference of temperature. It is a matter of common experience that when a hot body is placed in contact with a colder one, the hotter body becomes colder and the colder body becomes hotter. We say in such a case that "heat"

has passed from the hot body to the cold one. Thus when a kettle containing cold water is placed on the stove-plate, or on a fire, heat passes from the hot plate or fire to the cold water in the kettle. Also if a cold piece of metal is placed in contact with a hot piece heat passes from the hot piece to the cold piece until the two pieces attain the same temperature.

We may therefore define the difference of temperature between two bodies A and B as that condition which is essential for the transfer of heat to take place from A to B or B to A. If two bodies are at different temperatures, then when they are placed in contact heat passes from the body at higher temperature to the body at lower temperature. Or, if two portions of the same body are at different temperatures, heat passes from the portion at higher temperature to the portion at lower temperature. Similarly if two bodies are at the same temperature no heat passes from one to the other when they are placed in contact.

The transfer or exchange of heat between bodies not in contact belongs to the subject of radiation. See Chapter XIV.

4. Nature of heat. When a substance is heated it is said to gain or absorb heat. When it cools it is said to lose or give out heat. A question at once arises as to what may be the nature of what is here called heat. It is evidently not material, for the mass of a body does not change as it loses or gains heat. The question is specially dealt with in Chapter XVI., but it may be stated here, briefly, that whenever heat is produced energy in some form or other is found to disappear, and, in accordance with the theory of transformation of energy, it is recognised that this energy has been transformed into heat—and that heat is therefore a form of energy. Thus when coal burns in air the chemical energy of the products of the combustion is less than that of the original coal and air concerned, and the quantity of chemical energy so lost merely appears as the energy of heat. Similarly when a piece of lead is hammered the energy used by the wielder of the hammer is not lost, but is found as heat in the flattened piece of lead and in the hammer.

Hence, as a body is heated it gains energy in the form of heat, and as it cools it loses energy in the form of heat.

According to modern views of heat, the molecules of any given body are supposed to be vibrating to and fro, at a rate dependent on the temperature, and the sum total of the kinetic energy of its molecules, due to this vibratory motion, determines the **molecular kinetic energy** for any temperature. As the temperature increases this molecular kinetic energy increases, as does also the potential energy of the system of molecules, and the total change in molecular energy accompanying any thermal change is equivalent to the heat generated or absorbed during that change.

The process of combustion is capable of a similar explanation. All chemical change is due to molecular or atomic interaction, and it will be understood that the heat effect attending any chemical change may be due to a change in molecular energy resulting from this interaction.

5. Heat a measurable quantity. A quantity is that which can be expressed in terms of a fixed unit of its own kind, and its measure is the ratio of the given quantity to the chosen unit. Thus, if 2 is the measure of any quantity, the meaning is that the quantity considered is twice as great as the fixed unit—*e.g.* if a foot is chosen as unit of length, a length, the measure of which is 2, is two feet long. Let us now consider if heat is, in this sense, a measurable quantity.

Suppose that we have a hydrogen-gas flame whose rate of burning is absolutely uniform, we may assume that its heating effect is equal for equal intervals of time. If now a fixed quantity of water, at a given temperature, is heated by this flame for a given time, its temperature will be raised to a certain degree, indicating the absorption of a definite quantity of heat. An exactly equal quantity of water will, under the same circumstances, reach the same temperature in the same time, and will therefore absorb the same quantity of heat. Hence, if double the quantity of water is heated under precisely similar circumstances, it will be raised to the same temperature in double the time—

that is, after the absorption of double the quantity of heat. If, therefore, the quantity of heat absorbed in either of the cases first considered is taken as the unit, the measure of the quantity absorbed in this last case is 2.

Heat may thus be considered as a measurable quantity. The unit adopted in its measurement is quite arbitrary. We might, for example, take the unit to be the quantity of heat required to raise one pound of water from one particular temperature to another. Then the measure of the quantity required to raise m pounds through the *same* range of temperature would be m . This subject will be further considered in the chapter on Calorimetry (Ch. VIII.).

6. General effects of heat. When a body is sufficiently heated or cooled various well marked effects are generally produced. The general character of these effects is the same for most substances. The more important are included under the following heads—

- (1) Change of temperature.
- (2) Expansion or contraction, *i.e.* change of volume.
- (3) Change of state.
- (4) Change in physical properties.
- (5) Promotion of chemical action.

7. Change of temperature. This is almost axiomatic, for we have assumed that if the temperature of a body is rising it is absorbing heat. It is, however, only true when a body is not changing its state (Art. 9). When water is boiling its temperature remains constant; extra heat given to the water is used up in changing some of the water to steam, and the temperature of the steam is still the same as that of the water.

Again, when water is being frozen heat is removed from the water, but the mixture of ice and water still remains at the freezing point, and not until all the water has been frozen is it possible for the ice to get colder than this temperature. When, however, a substance remains in one definite state—solid, liquid, or gaseous—gain of heat produces a rise in temperature, loss of heat produces a

fall in temperature. Conversely a rise in temperature indicates a gain in heat, and a fall in temperature a loss of heat.

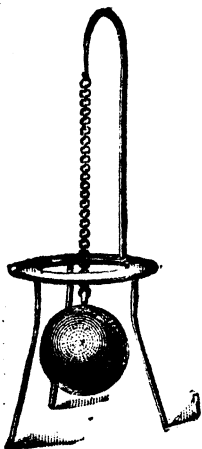

Fig. 1.

8. Change of Volume. It is found that in general* when a body is heated it expands, and will, if allowed to cool to its original temperature, gradually contract to its original volume. This is the same whether a body is a solid, a liquid, or a gas. The amount of contraction is different for different bodies; in general, gases expand more than liquids, and liquids more than solids for the same rise of temperature.

Gravesande's Ring and Ball (Fig. 1) is an historical piece of apparatus which is used to illustrate the change of dimensions which occurs on heating. The ball when cold may be passed through the ring. When heated it refuses to go through the ring. If allowed to rest in position and cool its dimensions in time become smaller than the ring and it falls through.

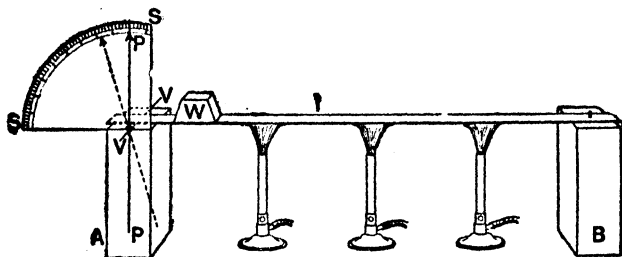

Fig. 2.

Exp. 1. Obtain a flat strip of brass about 18 inches long. Screw down one end on a fixed wooden block, B (Fig. 2), allowing the other

* Exceptions are water below 4°C ., silver iodide, Rose's fusible alloy, and some other alloys.

end to rest freely on a second block, A. If the top of A is not quite even cover it with a piece of finely ground glass or slightly roughened metal. Also, if necessary, roughen the under side of the end of the strip. Take a straight short piece of knitting-needle, V V, and to one end of it fasten by sealing-wax at right angles to its length a piece of straw, P P, six inches long to act as index. Insert the other end of the needle under the end of the strip. If the weight of the strip is not sufficient to keep the needle and pointer in any position in which they are put, a weight, W, sufficient for this purpose should be laid on the strip. Behind the pointer place a graduated circular scale SS. Now heat the strip by Bunsen burners and observe that the pointer slowly moves over the graduated scale, finally taking up a position of rest. Now the motion of the pointer tells us that the needle has rotated, and the cause of this rotation is obviously the expansion of the rod. Now remove the burners. As the rod cools the pointer moves back to its former position, showing that as the temperature falls the rod contracts.



Fig. 3.



Fig. 4.

Exp. 2. Fit a 4-oz. round-bottomed flask (Fig. 3) with a cork through which passes the end of a piece of coarse thermometer tubing about 8 or 9 in. long. Completely fill the flask with alcohol coloured with a little magenta dye. Then insert the cork so as to make the liquid rise a short distance in the tube. Now place the flask in a beaker of hot water. Observe that the liquid rises in the tube.

Exp. 3. Fit a 4-oz. round-bottomed flask (or, better, a bulb with very short neck) with a cork through which a piece of glass *quill* tubing passes nearly to the bottom (Fig. 4). Put in the bottom of the bulb a little coloured alcohol, into which the bottom of the tube is allowed to dip. Now hold the bulb in the hand. The heat thus imparted will, by causing the *air* in the bulb to expand, force some of the alcohol up the tube.

9. Change of State. Bodies may exist in three states—solid, liquid, and gas, and the change from one to the other may always be effected by the application or withdrawal of heat. Thus, for example, if ice is heated it melts into water, and if water is heated sufficiently it boils away and becomes steam. The reverse of the process is the withdrawal of heat from steam, when it condenses

to water, and the withdrawal of heat from water, when ice is formed. Again, air is a gas under usual conditions, but if subjected to intense cold it can be liquefied and even solidified.

10. **Change of physical properties.** It is found that heating and cooling modify in many ways the properties of matter. Iron heated to redness differs materially from iron at ordinary temperatures; zinc at ordinary temperatures is hard and brittle, but when warmed it is soft and flexible; steel may be softened or tempered by heating and cooling, and so on. Again, some bodies change colour on being heated: thus mercuric iodide is red at ordinary temperatures, but changes to yellow when heated.

The elasticity and rigidity of solids, the viscosity of liquids, the ease with which a substance conducts electricity, and, in fact, all the characteristic physical properties of matter change with change of temperature.

11. **Chemical change.** It is well known that heat frequently tends to promote chemical action. Thus coal, wood, sulphur, magnesium wire, and many other substances when heated with free access of air combine vigorously with the oxygen of the air, and we have the phenomenon of *combustion* or burning, which is simply oxidation accompanied by a large output of heat. Also coal, wood, and other compound substances when heated by themselves in a closed space undergo *decomposition*, and give rise to various products; thus coal gives rise to coal-gas and coal-tar.

Again, if calcium carbonate is heated to a high temperature it decomposes or *dissociates* into calcium oxide and carbonic acid gas. If the products of dissociation are cooled together calcium carbonate is again formed.

EXERCISES I.

1. Distinguish between heat and temperature.
2. Enumerate the effects of heat.
3. Describe experiments showing that solids, liquids, and gases expand on heating.

CHAPTER II.

THE THERMOMETER.*

12. Measurement of temperature. When we have said hitherto that an object was *hot*, we meant that when we touched it with the hand heat flowed from it to the hand; and when another object was said to be *cold*, we meant that when we touched it heat flowed from the hand to it. The *criterion*, therefore, was the temperature of the hand, and our judgments were based on *sensations*. To this method of estimating temperature there are three serious objections:—

(1) Our sensations are not sufficiently delicate. (2) They do not admit of numerical measurement. (3) The criterion (the temperature of the hand) is variable.

A reference scale of temperature might evidently be set up by selecting and arranging a series of standard temperatures each defined, as the temperature of melting ice is, as the temperature of some standard substance in a definite physical state. Any required temperature could then be specified loosely by referring it to its position on this scale of standard temperatures, but it is obvious that without some consistent method of comparing and graduating the intervals between the arbitrarily selected fixed points of the scale the exact specification of any temperature intermediate between two points is impossible.

It is, therefore, necessary to have some more certain means of comparing temperatures. Instruments called thermometers have been devised for this purpose.

DEFINITION.—The thermometer is an instrument for the comparison and measurement of temperature.

* Greek, *thermos*, hot; *thermē*, heat; *metron*, a measure.

13. Preliminary idea of a thermometer. We saw in Art. 6 that the effects of heat on matter are very diverse. The one which lends itself most readily to the measure of degree of hotness (or temperature) is that of change of volume (or expansion). So long as no change of state occurs expansion, in most substances, is simultaneous with change of temperature, and change of length or change of volume may therefore be taken to indicate change of temperature. Also, a particular length of any given rod or a particular volume of any given quantity of liquid corresponds to a particular temperature and may be taken as an indication of that temperature.

Exp. 4. Take a flask and tube as set up in Figs. 3 or 4, provide the tube with a graduated paper scale reading upwards, and carry it about to different parts of the building inside and outside. Near the fire it will be observed that the reading is highest. As it is taken to colder parts of the building note that the reading is low and to the hotter parts the reading is high. Suppose now that the reading when in Room A is the same as that when in Room B, what may we say about their temperatures? Proceeding on the above assumptions, obviously they are equal.

With a flask and tube as used in the above experiment the changes in the volume of the liquid are clearly indicated, and with a large bulb and a stem of very narrow bore an instrument capable of indicating very small changes of temperature may be constructed.

In practice a glass, flask, or bulb filled with mercury is found to work most satisfactorily, and such is invariably used if the temperature to be measured is likely to rise nearly as high as that of boiling water. If the indicator be provided with a scale etched on the stem its readings can be more readily noted and compared, and the usefulness of the instrument is greatly increased. The scale adopted may be quite arbitrary. A scale of millimetres, for example, would serve, but it would evidently be an advantage if the scale were arranged to indicate degrees of temperature in accordance with some generally understood and easily realised scale.

Such a scale may be obtained as follows: Let the temperature indicator be placed in melting ice, and when the

position of the liquid column in the stem is steady, let it be marked by a fine mark on the stem. This mark indicates the temperature of melting ice, which experiment teaches us to be a constant, naturally fixed temperature. Then place the indicator in steam from water boiling under the normal atmospheric pressure, and when the liquid column is again steady let its position be marked. This second mark indicates the temperature at which water boils under the normal atmospheric pressure, and this is again by experiment found to be a constant, naturally fixed temperature. These two temperatures are generally known as the *freezing point* and *boiling point* of water, and from these two *fixed points* a scale is readily derived.

14. The principle of graduation of a scale of temperature. The range of temperature between the *freezing point* and the *boiling point* may be divided into any number of steps by dividing the volume of the stem into a corresponding number of equal parts. For example, the range of temperature from freezing point to boiling point may be divided into 100 steps or *degrees* by dividing the volume of the bore of the stem between the two marks corresponding to these temperatures into 100 equal parts.

It should be carefully noticed here that nothing is said about dividing the range of *temperature* into 100 *equal* parts. The volume of the stem bore between the two marks is divided into 100 equal parts, but the corresponding steps or degrees of temperature indicated by these divisions may or may not be equal, and are evidently determined by and vary with the expansibility of the liquid used in the indicator. For example, if two indicators are accurately made and graduated in the way here described they will usually give two different scales of temperature; that is, if both were placed together in a bath where the temperature is gradually raised from freezing point to boiling point, it is probable that the temperature readings would agree exactly only at the fixed points. The question that here arises is not which is right, but which is to be adopted as the standard, that is, which is to be set up as "right" by definition and common convention. Hence, if an indicator of this kind is to be used as a standard instrument for general reference, the liquid and the material of the bulb and stem must be specified.

An instrument constructed and graduated on these principles to indicate temperature with reference to an

arbitrary selected scale is known as a thermometer. Certain substances are better suited than others for the measuring of temperature. A body which changes volume only to a small extent for large variations of temperature is not suitable. Solids are not used as thermometers because their alterations in size even when heated or cooled considerably are minute. Gases change volume very readily when exposed to different temperatures, and for certain purposes an air thermometer is a useful instrument. Liquids are, however, the best adapted for ordinary thermometry.

Of liquids, mercury is the best for all general purposes, because it boils at a very high, and freezes at a very low, temperature. Hence it remains liquid through a long range of temperature. Water has a comparatively small range of temperature between its freezing and boiling points. Alcohol is useful for measuring very low temperatures at which mercury would be frozen, and it is also used in some self-registering minimum thermometers, but it cannot be used for high temperatures because it boils at a lower temperature than the boiling point of water. Mercury has some other advantages. It quickly assumes the temperature of anything in which it is immersed without abstracting much heat from the substance, and it does not soil the glass. Standard thermometers are usually mercury-in-glass thermometers with a scale engraved on the glass stem.

15. Construction and filling of a mercury-in-glass thermometer tube. We now give the usual laboratory method of constructing a student's rough form of thermometer.

A length of thick capillary tubing, having as uniform a bore as can be found, is taken and well washed, first with a solution of potassium bichromate in strong sulphuric acid, then with distilled water, and finally dried by a current of hot air. Before proceeding to construct the instrument, it is well to make a preliminary test of the uniformity of the bore of the tube chosen. For this purpose, a short thread of mercury about an inch long is introduced by suction into the tube.

With a little management, a thread of the desired length may be got into the bore and moved into any part of the tube. This done, the length of the thread is measured by suitable means in a particular position in the tube; the thread is then moved into some other position, and again measured, and so on. If the length remains constant for different positions it is evident that the bore must be perfectly uniform. This is never found to be the case with any tube, and if the differences in length are very great the tube must be rejected and another tried. When finally a suitable tube is obtained, one end is heated till melted, and is then blown into a bulb. The size of the bulb is determined by the purpose the thermometer is intended to serve. The larger the bulb the longer will be the degrees of the scale.

In order to introduce mercury into the bulb a funnel-shaped reservoir is made at the top of the tube,* or a small funnel is attached to the tube by means of an india-rubber joint (Fig. 5), and more than sufficient mercury to fill the bulb is poured into it. The bulb is gently heated, so that the air in it expands, and some of it escapes by bubbling through the mercury. It is then allowed to cool, and as the air contracts a small quantity of the mercury from the reservoir enters the bulb. This process of alternate heating and cooling is continued until the bulb is about half full of mercury.

The bulb is then gently heated until the mercury boils and its vapour expels the air, which bubbles through the mercury in the upper reservoir. All traces of air and moisture are thus removed, and when the tube is allowed to cool the mercury in it forms a continuous column filling the bulb, stem, and part of the funnel. While still warm

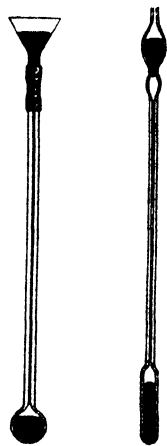

Fig. 5.

* Such thermometer tubes can be bought ready-made from most instrument makers.

the excess of mercury in the funnel is poured off and the tube is heated at a point just below the bulb and then drawn out so as to greatly constrict the bore. The bulb is now heated a little above the highest temperature the thermometer is intended to indicate. The mercury now completely fills the stem, and while it does so a blow-pipe flame is brought to bear upon the constriction and the upper part of the tube is drawn off and the thermometer finally closed.

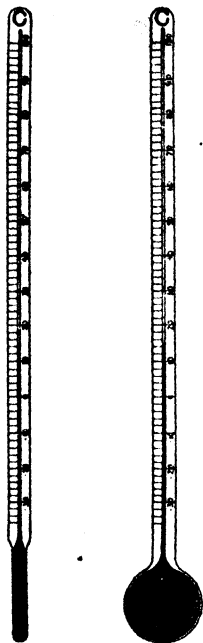

Fig. 6.

The instrument is now ready for graduation, but it is better to keep it from two to three weeks before proceeding with this process, because when glass has been heated to a high temperature it takes a long time (in some cases years) to recover its original volume.

Fig. 6 shows the usual forms of a mercury-in-glass thermometer.

If great accuracy is desired the thermometer should be kept for several months before graduation.

16. Determination of the fixed points of the thermometer scale. As a preliminary to graduation it will be necessary to mark on the stem the position of the thread corresponding to the two standard temperatures referred to above as the freezing point* and boiling point of water.

The freezing point. To determine this point the thermometer is placed in a cylindrical vessel † and the reservoir

* The lower fixed point is always called the *freezing* point, though, in reality, it is the *melting* point of ice, not the freezing point of water. The freezing point of water, in fact, is not constant, but is influenced by several circumstances.

† Sometimes a funnel is recommended for this purpose, but this is unnecessary, for as long as any ice remains in the cylinder the temperature is that of the freezing point.

and the lower part of the stem are completely surrounded by melting ice (Fig. 7). When the level of the mercury becomes perfectly stationary a fine mark is made on the stem at the extremity of the column. This is one of the fixed reference points on the scale and indicates the temperature of melting ice.

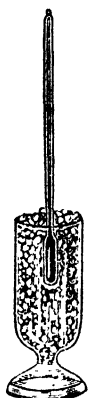

Fig. 7.

The boiling point. In order to mark this second point on the thermometer the apparatus shown in Fig. 8 is used. It is made of copper and the steam from water boiling in the lower part circulates round the double casing of the upper part, and finally escapes by a side tube near the bottom of the outer casing. The thermometer is passed

through a cork, and placed in the apparatus in the position indicated in the figure. After some time the mercury becomes stationary, and the thermometer is adjusted so that the top of the mercury column is just seen above the cork; its position is then marked, and the second reference point on the scale is thus determined. It indicates the temperature of steam from water boiling under the atmospheric pressure indicated by the barometer at the time of the determination. For the present we shall suppose this to be normal.

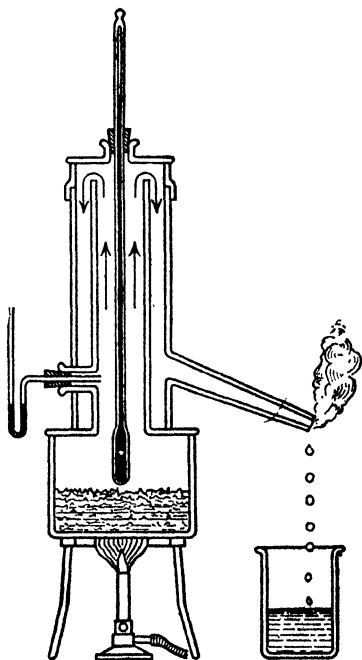

Fig. 8.

If such an apparatus as shown in Fig. 8 is not available—and it is not really necessary, except for the most accurate work—a flask

with a long neck may be used. The thermometer is supported by a clamp so that it hangs centrally down the neck of the flask, as much of the thermometer being in the flask as possible, care, however, being taken that the bulb is well above the boiling water. Figs. 11 and 12 give other suitable forms of apparatus.

It should be noticed that the thermometer is placed in the steam and not in the boiling water. It has been found that the temperature of boiling water depends on a variety of circumstances, whereas the temperature of the steam depends only on the pressure at which boiling takes place.

The distance between the freezing point and the boiling point on any given thermometer is sometimes called the fundamental interval of that thermometer.



Fig. 9.

17. Graduation of the thermometer. The two reference marks being thus obtained, it remains to graduate the space between them, and to continue the division throughout the whole length of the stem. A zero point is then chosen and the divisions below it are marked negative, and those above positive. There are three scales of graduation now in use; and as we may have temperatures expressed in any one of these scales, it will be necessary to consider them. They are called the Centigrade, Fahrenheit, and Réaumur scales (Fig. 9).

For the Centigrade scale we are indebted to Celsius, a Swede. On it the freezing point is taken as zero and marked 0° ; the boiling point is marked 100° . The space between the fixed points is thus divided into 100 equal divisions, called degrees. Graduation on the same scale is extended beyond the reference points; and the divisions below zero—*i.e.* below freezing point—are considered negative, and those above positive. This scale is the one most generally used for scientific purposes.

The Fahrenheit scale was introduced by Fahrenheit, a

German of Dantzic, about the year 1714. On it the freezing point is marked 32° and the boiling point 212° , the space between being divided into 180 equal degrees, and the division extended above and below the fixed points. In this method of division the zero is at a point 32° below the freezing point; it is supposed to indicate the lowest temperature which can be got by mixing snow and salt.* This scale is very generally used in Great Britain for the purposes of ordinary life, and to some extent for those of science, especially in meteorology.

On the scale invented by Réaumur, a Frenchman, the freezing point is taken as zero and marked 0° , and the boiling point is marked 80° . There are thus 80 equal divisions between the fixed points on this scale. It is used in several European countries for medical and domestic purposes, but is never used in England.

Having decided on the scale the thermometer stem is coated with paraffin-wax and the scale scratched thereon. The stem is then exposed to the action of hydrofluoric acid, when the exposed part of the stem is etched. The wax is then melted off.

A degree of temperature on any thermometric scale is the change of temperature corresponding to the expansion of the mercury in the thermometer from one division of the scale to the next.

A particular temperature on any thermometric scale is the temperature indicated by a thermometer when the mercury in the stem stands at a particular division on that scale. For example, the temperature 15°C . is the temperature indicated when the mercury in the stem of a mercury-in-glass thermometer stands at the 15th division above zero on the Centigrade scale.

It is sometimes necessary to convert temperatures expressed in one scale into the corresponding temperatures

* In Fahrenheit's original scale the upper fixed point was the temperature of a human being in normal health, and was taken as 24° . It was later altered to 96. The scale was now extended to the boiling point of water, which was found to be about 211° . The temperature of boiling water was now taken as 212, and on the scale as now amended the temperature of a human being is 98° .

in one of the other scales. To effect this it is also necessary to remember that the range of temperature from freezing point to boiling point is the same on each scale, and that the freezing point on the Fahrenheit scale is 32 degrees above the zero of that scale. Hence 180 degrees on the Fahrenheit scale are equivalent to 100 degrees on the Centigrade scale and 80 degrees on the Réaumur scale, that is 9 degrees Fahrenheit = 5 degrees Centigrade = 4 degrees Réaumur; and a temperature F on the Fahrenheit scale is $(F - 32)$ degrees above the freezing point.

If therefore F , C , and R denote corresponding temperatures on the Fahrenheit, Centigrade, and Réaumur scales we have the relation

$$(F - 32) : C : R :: 9 : 5 : 4 \text{ or } \frac{F - 32}{9} = \frac{C}{5} = \frac{R}{4}.$$

Example. If a Fahrenheit and a Centigrade thermometer are placed in the same liquid, and the Fahrenheit instrument reads 68° , what is the reading of the Centigrade instrument?

The liquid is $(68 - 32) = 36^\circ F.$ above freezing point.

Therefore the distance from the freezing point to the head of the mercury column

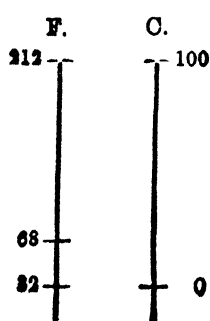

Fig. 10.

$= \frac{36}{180}$ (distance from the freezing to the boiling point)

$= \frac{1}{5}$ (distance from the freezing to the boiling point).

Therefore in the Centigrade thermometer also the distance from the freezing point to the head of the mercury column

$= \frac{1}{5}$ (distance from the freezing to the boiling point)

$= \frac{1}{5} \times 100 = 20.$

Therefore the indication on the Centigrade instrument is 20° .

Note.—In working such problems as this it is as well for beginners to sketch two thermometers side by side as in Fig. 10 in order to understand clearly that it is the tubes between the freezing and the boiling points which are to be divided proportionately.

18. Comparison of mercurial thermometers with one another. From what has been said it is plain that one important thing aimed at in the construction of thermo-

meters is, that the indications given by different but similarly constructed instruments may be comparable with one another, so that a temperature referred to by one experimenter may be reproduced by anyone wishing to do so. If it were possible to make all mercurial thermometers out of the same glass, their indications would be strictly comparable. This is, however, impossible; and it must further be remembered that the construction of a thermometer is a very difficult operation, and that, therefore, errors in construction are almost certain to be made.

For these reasons mercurial thermometers are not, in practice, strictly comparable; and it is usual to compare all thermometers, likely to be used in important experiments, with a standard thermometer. Such a standard is kept at the National Physical Laboratory at Teddington, and any thermometer sent there for comparison is returned with a table of corrections, the application of which will make its indications or *readings* strictly comparable with those of any other instrument similarly compared.

Exp. 5. Test the correctness of the freezing-point mark on a thermometer. Chisel off with a large chisel enough ice from a block of ice to fill a bottle or earthenware pot. Add a little water and insert the thermometer well into the mixture. Wait till the reading is constant, then note it down. The difference between the reading and the freezing point as marked is the error of the thermometer at this temperature. If the reading is above the freezing point the correction is negative, if below it is positive.

Exp. 6. Test the correctness of the boiling-point mark on a thermometer. A flask provided with a side tube and thermometer (Fig. 11) is most suitable for this purpose, or a flask may be fitted up with a side tube as shown in Fig. 12. The thermometer is thrust well down through the cork* until the bulb is about an inch or two above the

* The thermometer may even be supported in a clamp to hang centrally down the neck of the flask. No cork or side tube are then required.

water in the flask. Boil* the water for about five minutes; the mercury column should then be quite steady, and the position of the top of the column can be read. This will be the boiling point. Correct for pressure if necessary,† and then find the correction to be applied to the thermometer at this temperature.

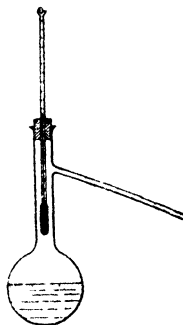

Fig. 11.

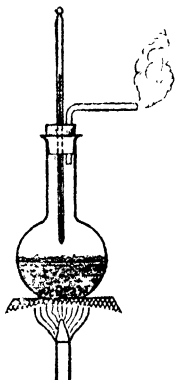

Fig. 12.

Exp. 7. Compare two graduated thermometers. Place the thermometers, A, B, together in a large water bath provided with a stirrer. One of the thermometers, A, is to be considered as the reference or standard thermometer. Warm the bath to definite temperatures as indicated by A, say 0° , 10° , 20° , etc. Note the respective readings of the other thermometer, B. Between the

* To prevent the water bumping as it boils, place a few fragments of unglazed earthenware (broken flowerpot) in the flask. When boiling occurs, a continuous stream of bubbles of steam will come off from these fragments, the boiling being continuous and comparatively gentle.

† The temperature of boiling depends on the atmospheric pressure. By definition (see Chapter XI.) the temperature of steam from boiling water is 100°C. only when the barometer reads 760 mm. at 0°C. at sea level in latitude 45° . If, therefore, great accuracy is required read the barometer. At sea level in the latitude of London the temperature of boiling is approximately $.0367^{\circ}\text{C.}$ below or above 100°C. for each millimetre that the barometer (corrected to 0°C.) is below or above 759.6 mm. (See Art 140.)

temperatures of observation the bath may be heated quickly, but when near to one of them adjust the Bunsen flame so that the temperature changes very slowly and stir well.

Compare a Fahrenheit thermometer with a Centigrade. Plot (i) the readings of the Fahrenheit thermometer with regard to those of the Centigrade, also (ii) Fahrenheit temperatures equivalent to Centigrade. (The latter is a straight line : $50^{\circ}\text{F.} = 10^{\circ}\text{C.}$, $140^{\circ}\text{F.} = 60^{\circ}\text{C.}$)

If the curve obtained in (i) is approximately a straight line, then the bore of B is practically as uniform as the standard. If the curve is definitely above or below the straight line of equivalent temperatures (ii), it is likely that the scale has been badly fixed to the stem.

19. Different forms of thermometers. For special purposes various forms of thermometers are used. The more important of these are described below.

The alcohol thermometer. Alcohol is sometimes used instead of mercury in the construction of thermometers. It has the advantage that it can be employed for very low temperatures: mercury solidifies at -39°C. , whereas alcohol may be exposed to a very much lower temperature (-130°C. without solidifying. It also expands much more (ten times) than mercury for the same rise of temperature. The expansion of alcohol is not uniform with temperature as indicated by a mercury-in-glass thermometer. The expansion increases with the temperature, and for this reason alcohol thermometers are usually graduated by direct comparison with a standard mercurial thermometer.

Another advantage of alcohol is that an alcohol thermometer has a less capacity for heat than a mercury thermometer of equal sensitiveness. A disadvantage, however, of the alcohol thermometer is that if the top of the stem is colder than the bulb the alcohol has a tendency to distil over from the bulb into the top of the stem, thus rendering the graduations temporarily inaccurate.

✓ **Pentane** is another liquid used in low-temperature thermometers.

Exp. 8. Graduate an alcohol thermometer. As alcohol boils at 78°C. , temperatures higher than this (amongst these is the steam-point) cannot be determined. Immerse (see Exp. 7) the ther-

mometer successively in baths at 70°C ., 60°C ., down to 0°C . (ice and water), and -10°C . (obtained by a mixture of ice and salt), as indicated by the standard thermometer. In each case mark the position of the alcohol surface with a piece of cotton tied tightly around the stem of the thermometer. Transfer the position of the cotton rings to a card, and divide the spaces so that the scale may read to degrees. Bind the card to the stem by fine wire.

High temperature thermometers. Mercury boils at 357°C . at normal pressure, and ordinary glass softens at high temperatures. In order to get thermometers which will read to high temperatures, up to 550°C . say, these difficulties are got over by using a very hard glass (borosilicate) for the thermometer and filling the space above the mercury with nitrogen at high pressure (16 atmospheres) to retard the boiling of the mercury. In other forms of high temperature thermometers the mercury is replaced by the liquid alloy of sodium and potassium. This alloy, which looks very much like mercury at ordinary temperatures, has a very high boiling point.

Electrical methods of measuring very high and very low temperatures. The electrical resistance of a metal wire varies with temperature in a simple manner, and as it is an easy matter to measure such resistance very accurately this variation of resistance affords an accurate means of measuring temperature.

Again, the thermoelectric current in a circuit containing two junctions of two different metals depends on the difference of temperature between the junctions, and this variation of current provides a simple means for the measurement of temperature. The advantage of both these methods lies in their applicability to very high and very low temperatures. For a further description see Chapter XVIII.

The air thermometer. When we come to consider what should be the properties of a perfect thermometric substance, we shall find that air (or some similar gas which closely conforms to Boyle's Law) comes nearest the required standard, and is sometimes used when very accurate measurements are required. More usually a mercurial thermometer which has been compared with an

air thermometer is employed. We shall consider the air thermometer when dealing with the expansion of gases.

20. Maximum and minimum thermometers. It is often necessary to know the highest or lowest temperature reached in a given interval of time. For instance, it is usual in making meteorological observations to record the highest (maximum) temperature attained during the day and the lowest (minimum) temperature reached during the night. For these purposes maximum and minimum thermometers are employed.

Six's maximum and minimum thermometer is one of the oldest of its class, and is at once a maximum and minimum thermometer. Its general plan of construction is shown in Fig. 13. The bulb B and part of the stem down to *m* is filled with alcohol. This is the real thermometric part of the instrument: the column of mercury, *m m'*, which occupies the U-shaped part of the tube merely acts as an index. Above *m'* the tube contains alcohol, as also does the lower half of the bulb C. The upper half of C contains alcohol vapour only, thus leaving room for expansion.

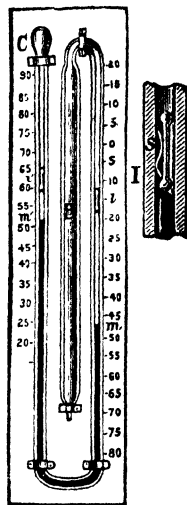

Fig. 13.

As the alcohol in B expands or contracts the extremities, *m* and *m'*, of the mercury column rise or fall as the case may be, and the extreme point reached in each case is indicated by one end of a light steel index, *i* or *i'* (shown on a larger scale at I). This index is pushed before the mercury column, and is prevented from returning by means of a spring, S, which is just strong enough to hold it in its place. The position of the index *i* evidently indicates the minimum temperature reached, and that of *i'* the maximum temperature. When it is required to set the instrument ready for any observation, these indices are brought into contact with the ends *m* and *m'* of the mer-

curial column by means of a small magnet. This instrument is largely used by gardeners and nurserymen.

Rutherford's maximum and minimum thermometers are two separate instruments, but are usually mounted on the same frame, as shown in Fig. 14.

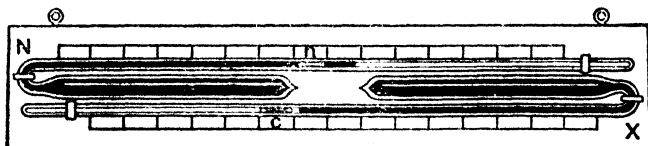

Fig. 14.

The maximum thermometer, X, is a modification of the ordinary mercurial thermometer placed in a horizontal position. The maximum temperature is registered, as in Six's instrument, by means of a steel index *c*. As the thermometer lies horizontally there is no necessity to attach a spring to the index. The maximum temperature will thus be indicated by the position of that end of the index which is nearest the bulb of the thermometer.

The minimum thermometer, N, is an alcohol thermometer, and is the only minimum thermometer in general use. It is placed in a horizontal position, and for registering the minimum temperature there is a small index of glass or enamel *n*, which allows the column of alcohol to expand past it without moving it; but when the alcohol contracts, the index, being wetted by the liquid, is drawn backwards by the surface film at the extremity of the alcohol column. The minimum temperature is thus indicated by the position of that end of the index which is furthest from the bulb.

The instruments are set by inclining the frame in such a way as to cause the indices to slide down to the ends of the liquid columns. They are largely used by meteorologists.

Phillips' maximum thermometer (Fig. 15) is a mercury thermometer with a very fine bore, in which the column of mercury is broken by a small bubble of air which separates a short thread of mercury from the rest of the

column. This thread takes the place of the index in Rutherford's thermometer. The instrument, which usually occupies a horizontal position, is set by placing it in a vertical position and gently tapping it. The bubble of air is thus reduced to its smallest dimensions, the gap in the column being about 1 mm. in length. When the mercury expands the index thread is pushed on so long as expansion continues. When contraction takes place the thread remains stationary, and the graduation is so arranged that the forward end indicates the maximum temperature experienced since the instrument was last set.

The ordinary clinical thermometer (Fig. 16) is a form of maximum thermometer. There is a constriction in the stem (*c*, Fig. 16). When the mercury expands it readily passes through the constriction, but when the mercury is cooling the column breaks at this point, as shown in the figure. The position of the upper end of the column left in the stem can thus be read at leisure. This thermometer is graduated to give a short range of temperature above and below 98.4° F., the normal temperature of the body. If placed in the mouth or armpit for a few minutes until it attains a stationary temperature its maximum reading gives the temperature of the body.

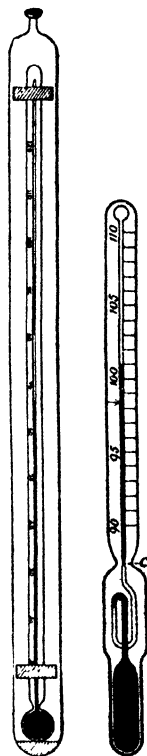

21. **Very sensitive thermometers.** When Fig. 15. Fig. 16. a salt is dissolved in water the temperature of the water is lowered. If the solution is now heated to boiling it will be found that the temperature of boiling is above that of the temperature of boiling of pure water, and if the solution is frozen its freezing point will be lower than the freezing point of pure water. In physical chemistry the measurements of the cooling produced by solution, the elevation of the boiling point and

the depression of the freezing point are of great importance and sensitive thermometers have been devised for the purpose.

It is obvious that if a small difference of temperature is to be measured accurately, the bulb of the thermometer must be large in comparison to the volume of unit length of the bore. If the thermometer is to read actual temperatures over a long range this would necessitate a very long stem. It is, however, not actual temperatures that are required but only differences of temperatures, so that a short-stem thermometer serves the purpose provided there is some means by which the end of the mercury column can always be got to rest within the limits of the scale.



Fig. 17.

Fig. 17 shows a Beckmann's thermometer designed for this work. It will be noted that the stem at the top of the tube is turned over and enlarged into a reservoir into which the excess mercury can be driven. For example, suppose that with the thermometer shown in the figure, whose stem covers a range of 6°C . and which reads to $\frac{1}{100}^{\circ}\text{C}$., we wished to measure the lowering of temperature when common salt is dissolved in water. The thermometer is heated to a temperature a little higher than the water so that the mercury column expands into the reservoir. The thermometer is now placed in the water, and the mercury column will come back to rest just below the upper limits of the scale. The salt is now mixed with the water, the water well stirred, and the cooling observed.

It will be noticed that with these thermometers the stem of the thermometer is quite a fine tube and is protected from outside by an enclosing tube fused on to the bulb of the thermometer. The scale is engraved on a piece of milk glass which fits behind the stem and between it and the outer sheaf. The walls of the bulb are very narrow, in order that the mercury shall soon arrive at the temperature of the bath in which it is

placed. Obviously the scale of such a thermometer must be calibrated by comparison with a standard thermometer. The quantity of mercury in thermometric use differs in different experiments, but the difference is so small that no correction to the size of the degrees is required on this account.

22. Sources of error in a mercurial thermometer. The more important sources of error are :--

(1) *Change of zero.* In many cases, if an ordinary mercurial thermometer, which has been made for some time, is placed in melting ice, it will be found that its indication is a little higher than the freezing point marked on the scale. The reason of this is referred to in Art. 15. If the thermometer tube has not been kept long enough before graduation, the gradual contraction of the bulb after graduation causes its interior volume to decrease, and consequently the volume of the contained mercury at 0° , although constant, appears to increase, and the level of the column corresponding to the freezing point rises. To correct this error, it is only necessary to re-determine the freezing point from time to time, and to deduct the observed error from any reading made. Thus, if zero is found, some months after graduation, to be at 0.1°C. , and the reading of the thermometer when placed in a bath of water is 64.5°C. , the correct temperature of the bath is 64.4°C.

(2) *Recent heating.* This is a temporary source of error arising from the same cause as *change of zero*. If a thermometer is heated to a high temperature and then allowed to cool, the bulb will for some weeks have a larger volume than the normal. Hence, if the thermometer is placed in a liquid of lower temperature, the mercury will not rise to the same graduation as it normally would, and the temperature it indicates will be lower than the real temperature of the liquid. The same thermometer must therefore not be used for determining low temperatures soon after it has been used for high temperatures. The error is merely temporary, and is, after a day or so, quite inappreciable.

It is for the above reason that, in the construction of thermometers, the freezing point is determined before the boiling point; if the latter were determined first, and the former soon after, the zero would be marked too low on the scale and would gradually rise, as explained above, under *change of zero*.

(3) *Temperature of the steam at time of marking the boiling point.* The temperature of steam depends on the atmospheric pressure under which boiling takes place. At 760 mm of mercury at 0° C. at sea level in latitude 45° , it corresponds to 100° C. or 212° F.; but if the pressure is greater or less than this, the boiling point indicates a temperature higher or lower than this temperature.

Tables have been drawn up from experiments by Regnault giving the boiling points corresponding to a wide range of pressures (see Table, p. 236). Hence, if the barometric height is read at the time of determining the boiling point, the temperature corresponding to this height can be obtained from these tables, and the graduation carried out accordingly.

(4) *Temperature of the stem.* When a thermometer is used to determine a temperature, it is often impossible to subject more than the bulb and a small portion of the stem to this temperature. The upper portion of the stem is thus at a different temperature from the rest of the tube, and consequently the reading will be slightly different from what it would be if the whole thermometer took up the temperature it is intended to indicate. If the temperature of the bath is higher than that to which the stem is exposed the reading is too low, and if the temperature of the bath is lower than that of the outside temperature the reading is too high. Approximate calculable corrections can be applied in both cases, and will be dealt with in the chapter on the Expansion of Liquids. In some cases this correction may be considerable.

(5) A thermometer should always be read in the position in which it was graduated; for, if the bore is very fine and the bulb thin, the influence of the pressure due to the contained mercury on the volume of the bulb may

cause an appreciable change of the reading when the position of the instrument is altered. It is obvious that the reading will be lowest when the thermometer is held vertical.

(6) *Inequality of bore.* Ordinary thermometers are graduated by dividing the distance between the two fixed points into a number of equal parts. This method is satisfactory if the bore is exactly uniform, but is obviously incorrect if the bore is larger at some parts than at others. Two methods are available for arranging that the readings shall indicate temperature correctly. One method is to graduate the bore so that the volumes between the marks are equal, the other is to graduate in equal lengths, as stated above, and then test the uniformity of the bore and so find out the correction which has to be applied at each division to give the correct temperature. (Particulars of these methods will be found in practical treatises.)

(7) Theoretically, corrections should be made for the pressure of the air at the time of determining the freezing point, and also for the influence of external pressure on the volume of the bulb; but these sources of error are, under suitable conditions, quite inappreciable.

From what has been said above it is obvious that it is not an easy matter to measure any particular temperature accurately, say to the thousandth of a degree. It is, however, fairly easy to measure accurately difference of temperature to this extent.

SOME COMMON OR IMPORTANT TEMPERATURES.

Centigrade.

7000	...	The sun
3500	...	The electric arc
2800	...	Oxy-hydrogen flame
2230	...	Temperature of Bessemer furnace
1710	...	Platinum melts
1500	...	Iron melts
1400	...	White heat
1200	...	Orange-red heat
1083	...	Copper melts
961	...	Silver melts
700	...	Dull red heat

Centigrade.	
400 ...	Coal ignites at about this temperature
357 ...	Mercury boils
327 ...	Lead melts
232 ...	Tin melts
115 ..	Sulphur melts
100 ...	Water boils (= 212° F.)
79 ..	Alcohol boils
53 ...	Highest shade temperature recorded
36·8 ...	Temperature of human body in health (= 98·4° F.)
17 ...	Mean temperature of sea (= 62° F.)
0 ...	Water freezes (= 32° F.)
-17·7 ...	Mixture of salt and ice (= 0° F.)
-39 ...	Mercury freezes
-61·7 ...	Record natural lowest temperature
-130 ...	Alcohol freezes
-183 ...	Oxygen liquefies
-253 ...	Hydrogen liquefies
-268·6 ...	Helium liquefies (the lowest temperature yet reached)
-273·1 ...	The absolute zero = - 459° F.)

EXERCISES II.

1. What do we mean by the *temperature* of a substance? State what properties of bodies we employ for the purpose of indicating temperatures.

2. What are the freezing and boiling points of a thermometer? They are commonly called fixed points: how do they differ under ordinary circumstances in respect of being fixed points? A temperature is 20° on Fahrenheit's scale: what is it called on the Centigrade scale?

3. Mercury freezes at - 40° C. What is the corresponding temperature on the Fahrenheit scale?

4. To how many Fahrenheit degrees of temperature are 20 Centigrade degrees equal, and what Fahrenheit temperature is the same as 20° C.?

5. Convert the following Centigrade temperatures into their equivalent temperatures in each of the other scales:—

$$850^{\circ}, \quad - 6^{\circ}, \quad - 50^{\circ}.$$

6. Convert the following Fahrenheit temperatures into their equivalents in each of the other scales:—

$$230^{\circ}, \quad 27^{\circ}, \quad - 10^{\circ}, \quad - 49^{\circ}.$$

7. Convert the following Réaumur temperatures into their equivalents in each of the other scales :—

$$116^{\circ}, \quad - 3^{\circ}, \quad - 27^{\circ}.$$

8. Prove the following formula for the conversion of Fahrenheit temperatures into Centigrade temperatures and *vice versa*.

$$C + 40 = \frac{5}{9}(F + 40),$$

or

$$F + 40 = \frac{9}{5}(C + 40).$$

9. A thermometer was calibrated with the following results :—

(a) Assuming the 0°C . and 100°C . points to be correct, the following table gives the corrections at the enumerated temperatures :—

10°	20°	30°	40°	50°	60°	70°	80°	90°
+ .12	+ .24	+ .27	+ .23	+ .12	+ .10	+ .08	+ .06	+ .06

(b) The correction at 0°C . is $- .20^{\circ}\text{C}$., the correction at 100°C . is $- .62^{\circ}\text{C}$.

Plot a curve between correction and temperature and find the corrections at 25° , 45° , 85°C .

CHAPTER III.

APPROXIMATIONS.

23. Every reading of an experimental result obtained in any one of the experimental sciences—Mechanics, Physics, Chemistry, etc.—is only approximate, *i.e.* it is not absolutely true. For example, suppose the length of a straight line is measured by an observer with a scale graduated to tenths of an inch. If he is not a trained observer he will give its length as, say, 7.9 inches and a bit more. A trained observer would estimate by eye what fraction of a tenth of an inch the line was over 7.9 inches. Suppose he gives the result as 7.92 inches. We may then assume that the true length of the line is something between 7.915 and 7.925 inches, *i.e.* we can only trust the result to the third significant figure.

Again, suppose in measuring the sides of a rectangle with a scale graduated to millimetres the readings are 4.34 and 2.76 cm., the fraction of a millimetre being estimated by the eye. Since $\text{area} = \text{length} \times \text{breadth}$, one might be inclined to say $\text{area} = 4.34 \times 2.76 = 11.9784 \text{ sq. cm.}$

It would, however, be wrong to think that such an answer was correct in its entirety, for the sides have not been measured sufficiently accurately to justify this. The longer side may be anything between 4.335 and 4.345, and the shorter side anything between 2.755 and 2.765. Assuming that the lowest estimates are the correct lengths, the area is found to be 11.9429 sq. cm.; and assuming the largest estimates are correct, to be 12.0139 sq. cm. We have now as the area of our rectangle a minimum estimate 11.9429 and a maximum estimate 12.0139, the difference being .071 sq. cm., and their mean is 11.9784. The area may thus be mathematically given as $11.9784 \pm .0355 \text{ sq. cm.}$, or in practical

language as 12.0 sq. cm., placing little reliance on the 0. Of course errors made in estimating one dimension may neutralise errors made in estimating the other dimension, but this cannot be depended on.

Again, suppose the above rectangle to be one face of a rectangular box the third side of which measured as before is 1.52 cm. Working out the volume by the usual rule we get $4.34 \times 2.76 \times 1.52 = 18.207168$ c.c. The volume may, however, be as low as $4.335 \times 2.755 \times 1.515$, i.e. 18.09353 c.c., or as high as $4.345 \times 2.765 \times 1.525$, i.e. 18.32123 c.c.

To be perfectly honest about it we can only give the volume as 18.2 c.c., placing little reliance on the 2; the third figure may be 1 or it may be 3.

It will be noticed that in the above examples the dimensions are measured to three significant figures in each case and the area or volume can only be trusted to three significant figures: hence we get the *general rule* that the result of calculations based upon measurements should only contain as many significant figures as there are in the least accurately measured datum.

Note.—Ciphers do not count as significant figures unless they lie between numbers which are not ciphers. Thus in either of the numbers 3002500 or .030025 there are five significant figures, viz. 30025.

In consequence of the rule above approximate methods of calculation can be used in nearly all physical work, with a great saving of time and trouble, and without sacrificing the accuracy of the work. If the number of factors to be multiplied or divided is large 4-figure logarithms are a great boon. These logarithms are quite accurate enough for most physical calculations. It is a waste of time to use 7-figure logarithms.

24. Small quantities occur frequently in problems on expansion, e.g. small increments of length, and the arithmetic containing these quantities is apt to consume much time unless some artifices are employed.

I. Note that the square or cube (or any higher power) of any very *small* quantity is very small in comparison with that small quantity itself. Thus

$$(0.002)^2 = 0.000004.$$

$$(0.002)^3 = 0.000000008.$$

Also the product of any two small quantities is negligibly small in comparison with either of those quantities. Thus

$$0.002 \times 0.003 = 0.000006.$$

It is evident then that in such an expression as

$$1.031 + 0.002 + (0.002)^2,$$

where the quantities are all derived from measurement, the correct answer is not 1.033004, but simply 1.033, for the third quantity is of much less importance than the possible errors in the first two quantities.

Example. What is the area of a square whose side when measured is found to be 1.003 cm. ?

By direct multiplication $(1.003)^2 = 1.006009$. The datum is accurate to four significant figures, hence this is also the accuracy of the answer, hence the area = 1.006 sq. cm. Using an elementary theorem in Algebra, viz.

$$(a + b)^2 = a^2 + 2ab + b^2,$$

we see that

$$(1 + 0.003)^2 = 1 + 2 \times 0.003 + (0.003)^2$$

$$= 1 + 2 \times 0.003 \text{ by the above}$$

$$= 1.006.$$

Hence, as a general rule, we may say :—When a is small a^2 is negligible in comparison with a , and

$$(1 + a)^2 = 1 + 2a.$$

Similarly $(1 + a)^3 = 1 + 3a + 3a^2 + a^3$ and in practice is equal to $1 + 3a$.

Again $(1 + a)(1 + \beta) = 1 + a + \beta + a\beta$. This when both a and β are negligibly small $= 1 + a + \beta$: for, in comparison with a and β , $a\beta$ is negligible.

Example. The sides of a rectangle are measured and found to be 1·00062 feet and 1·00045 feet. Find the area.

$$\begin{aligned}\text{Area} &= (1\cdot00062)(1\cdot00045) \\ &= 1 + \cdot00062 + \cdot00045 \\ &= 1\cdot00107.\end{aligned}$$

It may, however, be anything between 1·00106 and 1·00108.

II. Again, by actual division, the reciprocal of $1 - a$ where a is less than 1 is given by

$$1 \frac{1}{1-a} = 1 + a + a^2 + a^3 \dots$$

∴ When a is very small $\frac{1}{1-a} = 1 + a$.

Similarly under the same conditions

$$\frac{1}{1+a}, \text{ which } = 1 - a + a^2 - a^3 \dots$$

reduces to $1 - a$.

Also if both a and β are small

$$\begin{aligned}\frac{1+a}{1+\beta} &= (1+a) \left(\frac{1}{1+\beta} \right) = (1+a)(1-\beta) \\ &= 1 + a - \beta.\end{aligned}$$

Example. Divide 1·00038 by 1·00097.

$$\begin{aligned}\frac{1\cdot00038}{1\cdot00097} &= 1 + 00038 - \cdot00097 = 1 - \cdot00059 \\ &= \cdot99941.\end{aligned}$$

III. A summary of the above and some other simple results is here given. Remember that for the results to be true a and β must be very small in comparison with unity.

$$\begin{aligned}(1 \pm a)(1 \pm \beta) &= 1 \pm a \pm \beta \\ (1 \pm a)^2 &= 1 \pm 2a \\ (1 \pm a)^3 &= 1 \pm 3a\end{aligned}$$

$$\frac{1}{1+a} = 1 - a \text{ and } \frac{1}{1-a} = 1 + a$$

$$\frac{1 \pm a}{1 \pm \beta} = 1 \pm a \mp \beta$$

$$\sqrt{1 \pm a} = 1 \pm \frac{a}{2}$$

$$\sqrt[3]{1 \pm a} = 1 \pm \frac{a}{3}$$

IV. In working out numerical problems students will sometimes obtain **recurring decimals**. Now, on thinking of the real meaning of a recurring decimal it is evident that such a thing can have no place in physics. The nearest approximation, decimal or fractional, **must** be given in all cases.

Example. The perimeter of an equilateral triangle is found by measurement to be 25·1 cm. Find the length of the side.

Side = $\frac{1}{3}$ of perimeter = $\frac{1}{3}$ of 25·1 = ·83 $\bar{6}$.

This, however, means 8·36666666 *i.e.* an infinite accuracy is assumed, which is, of course, quite unjustifiable. The result should be stated as 8·37, the 7 even being very doubtful.

Again, working on another method, we say that the length of the perimeter may be anything between 25·05 and 25·15, *i.e.* the length of one side may be anything between 8·35 and 8·38, \therefore the answer given above, *viz.* 8·37, is not far wrong.

V. It is also easy to prove that squaring an inaccurate number doubles the inaccuracy, and cubing it trebles the inaccuracy.

It also follows that if the square root of a slightly inaccurate number be taken the inaccuracy is halved.

Throughout this book students should carefully observe how the above rules are applied. Contracted methods of working should be used whenever possible. "When calculating from observed quantities, it is dishonest to use more figures than we are sure of." (Prof. J. Perry in *Practical Mathematics*.)

EXERCISES III.

1. The numbers 1·312, 9·563, 3·569, 4·213 are known correct to 3 decimal places. Determine their sum and indicate the limits of error.

2. Determine the limits of error in $4\ 213 - 3\ 569$ (correct to 3 places).

3. The numbers 1·7324 and 2·5968 are correct to 4 places of decimals only (*i.e.* correct to 5 significant figures). How far can their product be relied on?

4. A line is measured and found to be 4·32 in. long. Express its length in centimetres given that 1 cm. = ·3937 in.

5. The radius of a circle is found to be 2·46 cm. Find the area.

Find the approximate value of--

6. $(1\cdot000021)(1\cdot000065)$. [*Type*, $(1+a)(1+\beta)$.]

7. $(1\cdot00018)(\cdot99982)$. [*Type*, $(1+a)(1-\beta)$.]

8. $(1\cdot00035)^2$; $(\cdot999987)^3$. [*Type*, $(1+a)^2$, $(1-a)^3$.]

9. $\frac{1}{1\cdot000025}$; $\frac{1}{0\cdot9987}$. [*Type*, $\left(\frac{1}{1+\alpha}\right)$, $\left(\frac{1}{1-\alpha}\right)$.]

10. $\frac{1\cdot00016}{1\cdot00004}$; $\frac{1\cdot00018}{0\cdot99986}$. [*Type*, $\frac{1+\alpha}{1+\beta}$; $\frac{1+\alpha}{1-\beta}$.]

11. $100 \left[\frac{1+10(\cdot000064)}{1-25(\cdot000008)} \right]$; $\frac{100}{1\cdot00016}$. [*Type*, $n \frac{1+\alpha}{1-\alpha}$; $\frac{n}{1+\alpha}$.]

12. $(4\cdot00072)^{\frac{1}{2}}$, $(4\cdot00072)^{\frac{3}{2}}$. [*Type*, $n^{\frac{1}{2}}(1+\alpha)^{\frac{1}{2}}$, $n^{\frac{3}{2}}(1+\alpha)^{\frac{3}{2}}$.]

CHAPTER IV.

EXPANSION OF SOLIDS.

25. In Art. 8, Exp. 1, it was shown that when a solid rod is heated its length increases. The increase of length is, however, very minute, and delicate means have to be devised for measuring it. Before proceeding to quantitative measurements it is well, however, to examine whether all substances expand on heating, and if so whether they all have the same expansibility.

Exp. 9. Take two similar strips of steel and copper

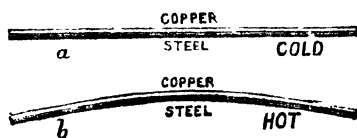

Fig. 18.

each about 10 in. long, $\frac{1}{2}$ in. wide, and $\frac{1}{32}$ in. thick, and solder or rivet them together along their whole length so that they are straight when cold. Heat the compound strip in the flame. Note what happens.

The strip becomes curved with the copper on the convex side, *i.e.* the longer side (Fig. 18). This shows that copper expands more than steel.

Exp. 10. Cut two strips of ebonite and deal each about 10 in. long, $\frac{1}{2}$ in. wide, and $\frac{1}{16}$ in. thick, and glue them together along their whole length. Repeat Exp. 9. Which expands the more when heated, the ebonite or the deal?

Exp. 11. Fuse a piece of copper wire into a glass rod. What happens when the rod cools? The glass fractures, the reason being that the copper contracts more than the glass, thus pulling the glass to which it is stuck away from the rest.

Exp. 12. Repeat the last experiment, substituting platinum for copper. No fracture occurs on cooling, showing that platinum and glass contract (and therefore expand) at about the same rate.

The result of experiments such as the above is to show that all common substances expand on heating and contract on cooling, the rates of expansion being different for different substances.

26. Linear and cubical (or volume) expansion. When a solid is heated it in general expands, and unless the substance is non-isotropic,* such as a crystal, it expands equally in all directions. For example, if a cube of an isotropic substance is heated each edge increases equally in length, each face increases equally in area, and the volume of the cube, as a whole, also increases. Increase of length is spoken of as *linear expansion*, increase in area as *superficial expansion*, and increase in volume as *cubical or volume expansion*.

The study of the amount of expansion may be made by exact measurements of change of length or by exact measurements of change of volume. When length measurements are made linear expansion is directly determined, and the corresponding superficial and cubical (or volume) expansions are deduced from the result. When volume measurements are made volume (or cubical) expansion is determined directly, and the corresponding linear and superficial expansions are deduced from the result. Hence in the measurement of expansion the determination of linear expansion or the determination of volume (or cubical) expansion may be made the starting point.

27. Rate of expansion with temperature. It must be remembered that the thermometric scale of temperature is derived from the expansion of mercury in a glass tube, and that successive degrees of temperature correspond to

* An isotropic body is a body whose properties are the same in all directions. Examples are metals, liquids, gases. The treatment in the text will refer only to isotropic bodies.

successive equal* increments of volume. Hence if we measured the expansion of any body degree by degree and found the same expansion for each degree rise of temperature we might say that the rate of expansion with temperature was uniform, but such a statement would merely mean that the body expands in exactly the same way as mercury in glass appears to expand.

It will be found that as a general rule substances expand in approximately the same way as mercury, that is, the increment of length or volume for each degree rise of temperature is approximately the same, and the expansion for one degree rise of temperature is approximately $1/n^{\text{th}}$ of the expansion for n degrees rise of temperature.

28. Coefficient of linear expansion. The following simple law has been established by experiments:—

► If different bodies of the same material are heated through the same range of temperature their lengths increase *by the same fraction of their lengths at 0° C.*

For example, if the temperature of any body made of copper is raised 1° C. on any part of the scale, then the increase of its length is found to be $\frac{1}{80000}$ of its length at 0° C. The fraction $\frac{1}{80000}$ is called the coefficient of the linear expansion of copper.

DEFINITION.—The coefficient of linear expansion of the substance composing a body is the ratio

$$\frac{\text{increase in length for 1° C. rise in temperature}}{\text{length at 0° C.}}$$

* It should, however, be noticed that the increments of volume for successive degrees of temperature are not strictly equal. In constructing a thermometer the volume of the bore between the fixed points is divided into equal divisions, but in using the instrument the volume of each division increases with the expansion of the glass tube as the temperature rises, so that the increment of volume for each successive degree slightly increases, and the increment of volume from, say, 99° C. to 100° C. is therefore greater than that from 0° C. to 1° C. by the increase in volume of a degree division due to the expansion of the glass tube between 1° C. and 100° C.

Simple problems on linear expansion are therefore easy applications of the Rule of Three. For harder problems it is preferable to employ a formula.

NOTE.—In some cases the solid does not exist at the temperature of 0°C . In that case the denominator can either be the length at some other chosen temperature or the length calculated for 0°C . from some formula. As an example, solid mercury melts at -39°C . and therefore is unknown at 0°C .

29. Formula for linear expansion. Let the length of a body at 0°C . be L_0 and at $t^{\circ}\text{C}$. be L_t , and let l be the coefficient of linear expansion.

Then increase of length when heated $t^{\circ}\text{C}$. = $L_t - L_0$;

\therefore " " " " 1°C . = $(L_t - L_0) \div t$.

Thus coefficient of linear expansion = $\frac{(L_t - L_0) \div t}{L_0}$;

$$\text{i.e. } l = \frac{L_t - L_0}{L_0 t}.$$

Obviously this formula may also be written in the form

$$L_t = L_0 (1 + lt).$$

30. Surface expansion. A body has the same coefficient of expansion whether we consider the expansion in length, breadth, or thickness. Knowing the increase in length and breadth, we can find by ordinary mensuration the increase in area or surface.

DEFINITION.—The coefficient of surface expansion of a body is the ratio

$$\frac{\text{increase in surface for } 1^{\circ}\text{C. rise in temperature}}{\text{surface at } 0^{\circ}\text{C.}}$$

Thus, if

S_0 = area of body at 0°C .,

S_t = " " " $t^{\circ}\text{C}$.,

s = coefficient of surface expansion,

then, arguing as in Art. 29, we obtain

$$s = \frac{S_t - S_0}{S_0 \cdot t},$$

or

$$S_t = S_0 (1 + st).$$

Next consider any portion of the surface in the shape of a square* whose side measures L_0 at 0°C. and L_t at $t^\circ \text{C.}$

$$\begin{aligned} \text{Then increase in area for } t^\circ \text{C. heating} &= L_t^2 - L_0^2 \\ &= L_0^2 (1 + \ell t)^2 - L_0^2 \\ &= L_0^2 (2\ell t + \ell^2 t^2); \end{aligned}$$

$$\therefore \text{increase in area for } 1^\circ \text{C. heating} = L_0^2 (2\ell + \ell^2 t);$$

$$\begin{aligned} \therefore \text{coeff. of surface expansion for this square} &= \frac{L_0^2 (2\ell + \ell^2 t)}{L_0^2} \\ &= 2\ell + \ell^2 t. \end{aligned}$$

But for any solid ℓ is very small, and therefore ℓ^2 is negligible.

Hence the coefficient of surface expansion for this square = 2ℓ .

This coefficient determines the rate of expansion for any square of any size which can be drawn anywhere on the surface. Hence the rate of expansion for the whole surface must be the same. Thus

$$\text{coeff. of surface expansion} = 2 \times \text{coeff. of linear expansion.}$$

Thus, to take an example, the increase in the surface of a copper body per rise of temperature of 1°C. is $\left(2 \times \frac{1}{60000}\right)$ or $\frac{1}{30000}$ of its surface at 0°C. , i.e. the coefficient of surface expansion of copper is $\frac{1}{30000}$.

The above is capable of an easy geometrical interpretation. For let the square

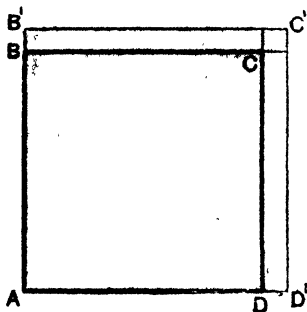

Fig. 19.

ABCD (Fig. 19) of unit side expand for a rise of temperature of 1° to the square $AB'C'D'$, where $BB' = DD' = \ell$, the coefficient of linear expansion. The increase in area equals the sum of the rectangles $B'C$, $D'C$ and the square CC' . The square CC' is of practically negligible area compared with the rectangles $B'C$, $D'C$, and the area of each of these rectangles is $1 \times \ell$,

therefore the increase in area is practically 2ℓ , which is thus the coefficient of superficial expansion.

* In the case of a curved surface, e.g. a sphere, only very small squares can be drawn upon it.

31. Volume expansion.

DEFINITION.—The coefficient of volume expansion (or cubical expansion) is the ratio

$$\frac{\text{increase of volume for } 1^{\circ} \text{ C. rise in temperature}}{\text{volume at } 0^{\circ} \text{ C.}}$$

Thus, if V_0 , V_t are the volumes at 0° C. and $t^{\circ} \text{ C.}$, and c the coefficient of cubical expansion, then

$$c = \frac{V_t - V_0}{V_0 t} \text{ and } V_t = V_0(1 + ct).$$

Next consider any portion of the volume in the shape of a cube, whose side measures L_0 at 0° C. and L_t at $t^{\circ} \text{ C.}$ Then, arguing as in Art. 30, it will be found that

$$\begin{aligned} \text{coeff. of volume expansion for this cube} \\ = 3l + 3l^2 t + l^3 t^2 = 3l, \end{aligned}$$

since l^2 and l^3 are negligible.

This coefficient determines the rate of expansion of any cube of any size taken anywhere within the volume of the body. Hence the rate of expansion for the whole volume must be the same. Thus

coeff. of volume expansion = 3 × coeff. of linear expansion.

Thus, to take an example, the increase in volume of a copper body per rise of temperature of 1° C. is $\left(3 \times \frac{1}{60000}\right)$ or $\frac{1}{20000}$ of its volume at 0° C. , i.e. the coefficient of volume expansion of copper is $\frac{1}{20000}$.

This theorem also admits of an easy geometrical proof. Let the unit cube $ABECFDG$ (Fig. 20) of any material expand to the cube $AB'C'D'E'$ for a rise of temperature 1° , the corner at A remaining fixed. $BB' = CC' = DD' = l$, the coefficient of linear expansion. The increase of volume is made up of three square slabs which stand on the three faces BEG , DFG , CEF of the cube and of height BB' ,

DD' , CC' respectively, three square prisms EH , FK , GL , and the corner cube HKL . Since the increase of

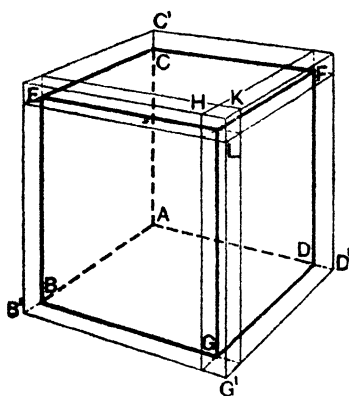

Fig. 20.

edge of the cube $ABCD$ is very small the volumes of the prisms and corner cube are negligible in comparison with the volumes of the three slabs. The volumes of each slab is $1 \times 1 \times l$, *i.e.* l , and thus the coefficient of volume expansion is practically $3l$.

We shall see later that the volume expansion, and consequently the linear expansion, of a solid substance may be obtained indirectly by observing the expansion

of a liquid in a vessel composed of that substance.

32. Lengths and volumes at different temperatures.

Let L_0 , L_t , $L_{t'}$ be the lengths of a rod at 0°C ., $t^\circ\text{C}$., and $t'^\circ\text{C}$., t' being greater than t , and let l be the coefficient of linear expansion of the substance composing the rod.

Then

$$L_t = L_0 (1 + lt)$$

$$L_{t'} = L_0 (1 + lt')$$

$$\therefore \frac{L_{t'}}{L_t} = \frac{1 + lt'}{1 + lt} = (1 + lt')(1 - lt) = 1 + l(t' - t) \text{ approx.}$$

$$\therefore L_{t'} = L_t (1 + l(t' - t)) \dots\dots\dots (1)$$

a very useful relation when the length is given at some temperature other than 0°C .

The student should prove in like manner that

$$V_{t'} = V_t (1 + c(t' - t)) \dots\dots\dots (2)$$

Formulae (1) and (2) are only approximate and should not be used when the coefficients of expansion and the difference of temperature are large. Scarcely any error is obtained when they are applied to solids. In the case of

liquids their application is sufficiently accurate for most purposes, but in the case of gases the expansion is far too great to admit of these approximations.

Examples. In problems on expansion it is better to work from first principles than to calculate mechanically from the formula.

(1) *Having given the length of a solid at one temperature and its coefficient of expansion, to find the length at another temperature.*

The length of a copper rod at 10°C. is $200\cdot34$ in. Find its length at 100°C. , the mean coefficient of expansion being $\cdot0000170$.

Difference of temperatures is $100 - 10 = 90^{\circ}$. A length l at 10°C. increases by $90 \times \cdot0000170$ or $\cdot00153$ when heated to 100°C.

Since 1 increases by $\cdot00153$,
 $\therefore 200\cdot34$ in. increase by $\cdot306$.
i.e. the length at 100°C. is $200\cdot65$ in.

Note.—In working this example it is assumed that the rod expands $\cdot000017$ of its length at 10°C. for each degree of increase of temperature. This is not strictly true. The rod expands $\cdot000017$ of its length at 0°C. ; but, as its length at 10° is very nearly the same as at 0° , no appreciable error is made.

(2) *To find the coefficient of expansion, having given the length, volume, or area at two different temperatures.*

The volume of a piece of glass at 100°C. is $100\cdot258$ c.c., and its volume at 0° is exactly 100 c.c. Find the mean coefficient of cubical expansion.

$$100\cdot258 \text{ c.c.} - 100 \text{ c.c.} = \cdot258 \text{ c.c.}$$

The increase in volume for 100°C. is $\cdot258$ c.c. Hence for 1° it is $\cdot258/100$ or $\cdot00258$.

Hence the coefficient of cubical expansion is

$$\frac{\cdot00258 \text{ c.c.}}{100 \text{ c.c.}} \text{ or } \cdot0000258.$$

The coefficient of linear expansion is $\frac{1}{3}$ of this, or $\cdot0000086$, and that of surface expansion is double this, *i.e.*

$$2 \times \cdot0000086 \text{ or } \cdot0000172.$$

(3) The coefficient of linear expansion of glass is $0\cdot0000083$. Find the volume at 15°C. of a glass flask of exactly 1 litre capacity at 0°C.

In dealing with hollow vessels note that if the space inside was exactly filled up with the same medium as the vessel is composed of, and the vessel and contents were heated, the matter put in would exactly fill the vessel at all temperatures. But the volume of the matter put in is equal to the capacity of the vessel, hence the

increase of volume of a hollow vessel depends upon the volume expansion of the matter composing the vessel.

The coefficient of volume expansion of glass is 0.000025. The increase in capacity of the flask per degree is 0.000025×1000 , and therefore the increase for 15°C .

$$= 0.000025 \times 1000 \times 15 \text{ c.c.}$$

$$= 0.37 \text{ c.c.}$$

Hence capacity at 15°C . = 1000.37 c.c.

33. Mean coefficient of expansion. The fraction $\frac{L_t - L_0}{L_0 t}$ has been defined above as the coefficient of ex-

pansion between 0° and t° . If the expansion is regular the coefficient of expansion between 0° and t° is the same as the coefficient at all temperatures between 0° and t° .

If, however, the expansion is not regular $\frac{L_t - L_0}{L_0 t}$ must be

called the *mean* coefficient of expansion between 0° and t° , and if we wish to determine the true coefficient of expansion at t° we must proceed somewhat differently.

Let L_t = the length at t° and $L_{t'}$ the length at a temperature t'° a little above t° . Then the mean coefficient of expansion between t° and t_1° is evidently $\frac{L_{t'} - L_t}{L_0 (t' - t)}$. If

now t be considered constant and t' be made to approximate nearer and nearer to t , then $(t' - t)$ and consequently $(L_{t'} - L_t)$ become smaller and smaller and the ratio

$\frac{L_{t'} - L_t}{L_0 (t' - t)}$ tends to a certain limiting value* which is the true coefficient of expansion at $t^\circ \text{C}$.

Perhaps this argument may be made easier by considering an analogous problem in dynamics. Suppose that a moving body passes over ten feet in five seconds. The mean or average velocity is two feet per second. If the velocity is uniform, then we may say that, in each second, the body passes over two feet. If, however, the velocity is variable, all we can say is that, on the average, two feet is passed over in each second, though, if we consider

* For a further treatment of the subject of limiting values a text-book of Algebra may be consulted.

any one second, the body may have passed over more or less than two feet. We may then ask, What is the *true velocity*, at any instant, of a body moving with variable velocity?

Suppose S_t to denote the space passed over in t seconds after starting, and $S_{t'}$ the space described in t' seconds from the start (t' being a little greater than t). Then the space $(S_{t'} - S_t)$ is described in $(t' - t)$ seconds, and therefore the mean velocity for this interval of time = $\frac{S_{t'} - S_t}{(t' - t)}$. Now, it is evident that, the smaller the interval $(t' - t)$ is, the more nearly will the ratio $\frac{S_{t'} - S_t}{(t' - t)}$ give the true velocity at a definite instant of time. If, then, t be considered constant, and t' be taken more and more nearly equal to t , the ratio $\frac{S_{t'} - S_t}{(t' - t)}$ tends to a definite limiting value as $(t' - t)$ becomes more nearly equal to zero, by the approach of t' to t ; and this limiting value is the true velocity of the body at an instant t seconds after starting.

34. Graphical representation of expansion problems.

Let OT (Fig. 21) be the axis of temperature and OL the

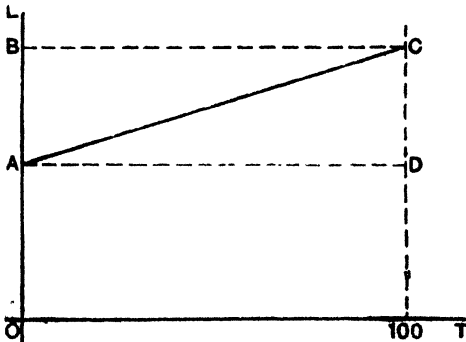

Fig. 21.

axis of length. Let OA represent the length of a rod at 0°C ., and OB the length at 100°C . Then the point C

represents the rod at 100°C . and the mean coefficient of expansion from 0°C . to 100°C . = $\frac{OB - OA}{100 \cdot OA} = \frac{CD}{100 \cdot OA}$.

If the expansion is uniform, i.e. the rod increases by the same amount for every equal rise of temperature, it is obvious that the graph showing the relation between length and temperature is the straight line AC. The equation of this line is $L_t = L_0 (1 + lt)$ where $l = \tan \angle CAD$; the value of l is what we have called the coefficient of linear expansion.

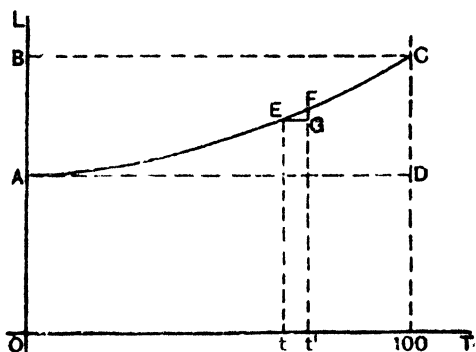

Fig. 22

If the expansion is not uniform the graph showing the relation between length and temperature will be curved. Fig. 22 shows the graph in the case when the coefficient of expansion increases with temperature. The line AC in this case is concave upwards. The mean coefficient of expansion from 0°C . to 100°C . is $\frac{1}{100} \cdot \frac{CD}{OA}$ as before.

To get the coefficient of expansion at an intermediate temperature t take another temperature t' , a little above t , and draw ordinates at t, t' to cut the graph in E and F. Draw EG perpendicular to Ft' . Then for the small elevation of temperature $t' - t$ the expansion is FG, and therefore the coefficient of expansion at t' is equal to the limiting value of $\frac{1}{OA} \cdot \frac{FG}{EG}$ when E and F are indefinitely

close together. Now the line EF is practically the tangent to the graph at E when E and F are close together, and absolutely so when E and F are indefinitely close together. Hence the coeff. of expansion at $t^\circ C$.

$$= \frac{1}{OA} \times \{\text{Tangent of the angle the tangent at } E \text{ makes with } OT\}.$$

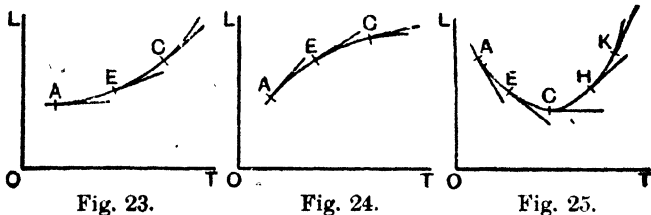

The slope of the curve thus readily affords an indication of the variation of the coefficient of expansion. In the graph shown in Fig. 23 the coefficient of expansion increases as we go from A to C . In Fig. 24 it decreases, and in Fig. 25 the coefficient of expansion is negative and numerically decreasing as we go from A to C , and then positive and increasing as we go from C to K .*

35. Laboratory methods of measuring the coefficient of linear expansion. The expansion of most solid bodies with rise of temperature is so small that delicate means of measurement have to be adopted. In the method usually adopted either a microscope or a micrometer screw is used.

Microscopes suitable for the purpose must be of low power, *i.e.* the field of view should be about 2 mm. diameter. One form is provided with an eyepiece scale, the value of whose divisions in millimetres is easily obtained by focusing the microscope upon a scale graduated to tenths of a millimetre and noting coincidences at both ends of the field. For instance, suppose 32 eyepiece-scale divisions exactly

* In ordinary cases the mean coefficient of expansion between two fairly near temperatures t_1 and t_2 is almost exactly equal to the coefficient at the temperature $\frac{1}{2}(t_1 + t_2)$, halfway between.

cover 8 tenths of a millimetre, then 1 eyepiece-scale division represents 0.0025 cm.

Another form of microscope is provided only with cross wires, but it slides along a slotted base and its position is measured by a very accurate vernier *

Micrometer screws suitable for the purpose may be of either the screw-gauge or spherometer type.* The essential principle in each is an accurately made screw of fine pitch, generally $\frac{1}{2}$ mm., working in a fixed collar. Graduations on the collar indicate the number of complete turns the screw has progressed, while graduations on a disc fixed perpendicularly to the end of the screw indicate the fraction of a complete turn.

Exp. 13. To determine the coefficient of linear expansion of brass. Take a brass tube not less than half a metre in length and about 5 mm. in internal diameter.

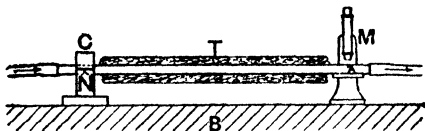

Fig. 26.

Near one end file a deep notch, N (Fig. 26), and near the other scratch a sharp clear line, A. Measure with a millimetre scale the distance between A and N. Mount the tube horizontally, the notch fitting over a knife-edge on which it can be clamped, and the other end resting on the stage of a microscope so that A can be viewed. Work on a large stone bench if possible. Attach rubber tubes to the ends of the brass tube. Pass a current of cold water through the tubes from the supply system.

Take the reading of A on the eyepiece scale. Take the temperature of the water as it leaves the tube. Now pass a current of steam through. Observe—in the microscope—the gradual motion of A outwards from N. When A has

* Full details of these instruments should be obtained either from the instruments themselves or from a book of Practical Physics.

come to rest read its position again. At the same time read the temperature of the steam in the boiler. (This is hardly necessary : if the barometer is near the normal the steam temperature may be assumed to be $100^{\circ}\text{C}.$)

To prevent condensation in the tube and the possibility of its temperature not being that of the steam, the tube may be wrapped around with a layer, T, of cotton-wool. To make sure that the readings are correct, pass cold water again through the tube and see if A returns to its old position.

From the two microscope readings find the distance in millimetres through which A has moved. Divide this by the product of the length, N A, and the difference in temperatures of the cold water and the steam: the result is the coefficient of expansion of brass.

Example. In a certain experiment, when water of temperature of $10^{\circ}\text{C}.$ was passing through the tube the reading of A was 2.4, when steam at $100^{\circ}\text{C}.$ was passing the reading was 43.6. The length of N A was 60.0 cm. and 1 division of the eyepiece scale was equal to 0.0025.

Then the coefficient of expansion = $\frac{(43.6 - 2.4) \times .0025}{60.0 \times 90} = .000019.$

Exp. 14. To determine the coefficient of linear expansion of a brass rod. Mount the rod on corks, C, C,* and place

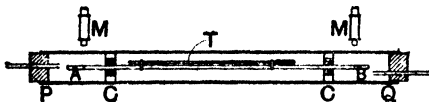

Fig. 27.

it inside a glass tube (as in Fig. 27) through which water and steam can be passed. For the measurement of the change of length use two microscopes, M, M, focussed on two fine lines, A and B, one on each end of the tube. A thermometer may be tied on to the rod itself. Readings at an intermediate temperature, say 50° or 60° , may be

* Holes must be bored through the corks to allow free circulation of the water and steam.

obtained by slowly passing warm water from a large tank through the tube. Put a thermometer in the tank and in the outlet water, and make quite sure that the temperature and the positions of A and B are stationary before reading them. Show from the results obtained that the expansion is proportional to the change of temperature.

Exp. 15. Find the coefficient of expansion of iron. As before, take an iron tube, close up one end by a flat piece of metal, and solder or screw into the tube near it a short tube to act as an outlet. Mount as before, but instead of a microscope take a micrometer screw,* and, by fixing the collar in a clamp, arrange the clamp so that the screw itself can be brought up to the flat cap. Take readings with cold water and steam as before.

There are many other methods in use; they differ chiefly in the devices which are used to measure the small change of length.

36. Historical methods of measuring the coefficient of linear expansion. The most important of these are the indirect method due to Laplace and Lavoisier, and the direct method of Roy and Ramsden.

Laplace and Lavoisier magnified the increase in length by mechanical and optical means. Their results are not very accurate.

37. Roy and Ramsden measured *directly* the expansion of the rod by a micrometer screw. The pitch of the screw was $\frac{1}{50}$ inch and the head was divided into 100 parts, so that measurements could be made as fine as $\frac{1}{5000}$ in. The method, as slightly modified by later experimenters, is shown *diagrammatically* in Fig. 28. Three troughs are placed on a table parallel to one another on props. In each of the two outer troughs is placed a metal rod, A B, E F respectively, and on props in the middle trough is placed the rod C D, whose coefficient of expansion is to be

* A spherometer is useful for this experiment. If one of the legs is fixed in the clamp, the screw can be brought to touch the flat piece, closing the end of the tube. If a screw gauge is used, the flat piece closing the end of the tube must project sideways, so that the butt of the gauge does not come in the way.

measured. The three rods are approximately of the same length and near each extremity is fixed vertically a small upright.

The uprights on AB carry cross wires a and b , as shown in Fig. 29. The uprights on EF carry horizontal rods on which are fixed cross wires e and f and equal lenses

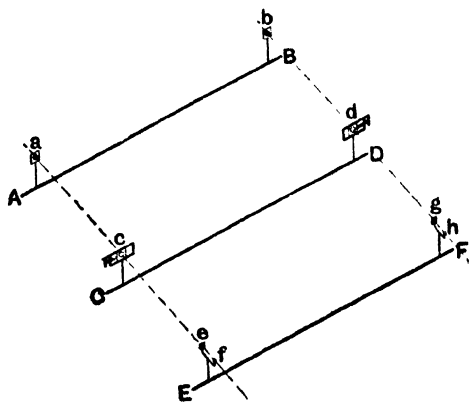

Fig. 28.

f and h . The upright at the C end of CD carries a lens c , the upright at the D end carries a frame in which slides another frame (see Fig. 30) carrying a lens d exactly equal to c . The lens frame can be moved parallel to the



Fig. 29.

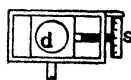

Fig. 30.

length of the bar by means of an attached micrometer screw, s . The system $acef$ forms a telescope in which an image of a formed by c is viewed through f , and its position relative to e observed. The system $bdgh$ forms another exactly similar telescope.

The three troughs are filled with melting ice and the rods adjusted until on placing the eye at f the intersection

of the cross wires e exactly covers the image of the intersection of the cross wires a . Placing the eye at L the micrometer screw is adjusted until the intersection of cross wires g exactly covers the image of the intersection of cross wires b . The reading of the screw is now taken.

The ice in the central trough is now melted and the water heated to boiling. CD expands and most likely c moves to the left of the straight line aeg and d to the right of the straight line bgh . The centre trough is now gently moved until c is brought back into line with aef , and now the micrometer screw is again adjusted until d is brought into line with bgh . The reading is again taken and the difference in the two readings gives the amount lens d has been moved to the left, *i.e.* the amount the length of the rod CD between the uprights has expanded on being heated from 0°C. to 100°C. From this the coefficient of linear expansion is deduced.

This method is interesting, as it was devised by Ramsden and Roy to determine the true lengths of the metal rods used in measuring the base-line on Hounslow Heath when making the first Ordnance Survey of Great Britain.

COEFFICIENTS OF LINEAR EXPANSION OF SOLIDS.

These are *mean coefficients between 0°C. and 100°C.* As they differ slightly for different specimens of the same substance it must be understood that they are only approximate.

Invar (a nickel steel)	·000009
Quartz	·000017
Glass	·000086
Platinum	·000089
Cast Iron	·000011
Steel	·000012
Copper	·000017
Brass	·000019
Silver	·000019
Lead	·000028
Tin	·000023
Ice (between 0°C. and 50°C.) ...	·000053
Oak	·00005
Sulphur	·00006

The coefficients given on the last page refer to the Centigrade scale, but they may be converted to refer to any other scale. The student, for example, should prove that the coefficient of expansion per degree Fahrenheit is equal to five-ninths of the coefficient of expansion per degree Centigrade.

38. Anomalies in the expansion of solids.

(1) If an iron wire is gradually heated it expands until the temperature is approximately that of a dull red heat. It then contracts, and after that expands again. This anomalous contraction occurs at the temperature at which iron loses its magnetic properties. Evidently at this temperature the molecules of the iron suffer some rearrangement.

(2) Dr. Joule discovered that, although the coefficient of expansion of vulcanised caoutchouc is very large, if a rod of this substance be stretched the expansion on heating diminishes, and that if the weights used are sufficiently great it actually contracts when heated. It is sometimes said that the coefficient of expansion of stretched caoutchouc is negative, but what really happens is that the elasticity of caoutchouc increases on heating, so that a larger force is required to cause the same elongation as at lower temperatures.

(3) Iodide of silver when heated contracts until the temperature is 116°C . At this temperature the substance changes into an allotropic modification.

(4) Rose's fusible metal, which consists of two parts bismuth, one part lead, and one part tin, expands from 0°C . to 59°C ., and then contracts up to 96°C ., when it melts.

(5) Crystals expand differently in different directions; they are not isotropic (see Art. 26).

39. Volume expansion of solids. It will be understood after a study of the Expansion of Liquids that the measurement of the volume expansion of solids involves exactly the same methods as those adopted for the measurement of the volume expansion of liquids, and that

the experimental study of the volume expansion of solids and liquids is practically one subject.

In the early stages of research into the expansion of solids and liquids all experimental work on the expansion of liquids was complicated by the expansion of the vessel containing it, and this presented a serious obstacle to the advance of research. The results obtained always involved the coefficients of expansion of a liquid and a solid, and neither could be accurately determined unless the other was known. If the absolute expansion of any one liquid or solid were known this could be taken as a starting point for the determination of other coefficients.

Attempts were made to obtain a starting point of this kind by making exact determinations of linear expansion, but at that time it was found impossible to make determinations of sufficient accuracy. This difficulty was, however, done away with by the discovery of Dulong and Petit's method of determining the absolute expansion of a liquid, and Regnault's determination of the coefficient of absolute volume expansion of mercury gave the starting point of all accurate determinations of coefficients of volume expansion for solids and liquids.

40. Practical precautions necessary on account of expansion of metals by heat. The expansion of metals is very frequently a source of trouble. Thus, in constructing a railway, small spaces have to be left between the metals to allow for expansion due to the extreme yearly range of temperature. Similarly, allowance must be made for expansion in constructing an iron bridge, and it is often difficult to secure rigidity and yet allow each part freedom of expansion. The tubular girders of the Britannia Bridge are mounted on rollers at each end, so that they may be free to expand, without straining the structure. For the same reason, the joints of water pipes and gas mains are made like those of a telescope. If furnace bars are firmly fixed they become bent, owing to the expansion which they undergo on heating; for this reason the ends of the bars should be free to move in the direction of their length.

Metal castings often break in cooling, on account of one part cooling more rapidly than another, and thus producing great strains in the metal. For example, in casting a wheel with a thin rim but massive arms, the rim solidifies and cools much more quickly than the arms, and as a consequence the contraction of the latter is opposed by the rim, and a stress is set up which may fracture the rim or one or more of the arms. To avoid this, the arms are often bent: they then can yield to the strain without breaking.

Exp. 16. Go to a railway station and note how expansion is allowed for in the rods working the "points." Make a careful diagram of the device adopted.

Exp. 17. Pour boiling water into a thick glass bottle. The bottle breaks. Now pour boiling water into a thin glass beaker. The beaker does not break. Explain why there is this difference.

The imperial standard yard is the distance, at 62° F., between two fine lines engraved on gold plugs, which are inserted into a bronze bar kept in the Standards Office, and in all measurements made by metal rods or chains the temperature must be noted, and a correction applied.

In the construction of clocks, chronometers, and watches of the best kind, great precaution has to be taken to obviate the effects of expansion on the time-keeping part of the mechanism. The rate of a clock is generally controlled by a pendulum, whose time of vibration varies as the square root of its length, or, more accurately, as the square root of the distance between two points called respectively "the centre of suspension" and "the centre of oscillation."* If the temperature varies this distance varies, and the clock goes "slow" as the temperature rises and "fast" as the temperature falls. Compensated pendulums are constructed to prevent this change of rate with change of temperature.

Example. The rod of a certain pendulum is made of light wood 45 in. long, and supports on a flange at its lower extremity a heavy metal cylinder, which fits loosely around the rod. What must be

* See Wagstaff's *Properties of Matter*, § 93.

the length of the metal cylinder in order that the rate of the pendulum may not vary with the temperature? The coefficient of linear expansion of the wood is $\cdot 000040$ and of the metal $\cdot 000060$.

Fig. 31 represents the pendulum. The centre of suspension O will be near the top of the wooden rod, and the centre of oscillation P will be practically at the centre of gravity of the zinc cylinder. The length of the metal cylinder must be chosen to make the distance OP invariable with temperature, *i.e.* if A is the bottom of the rod and cylinder, the length OA of rod must expand just as much as the length AP of cylinder.

Therefore $OA \times$ coefficient of linear expansion of rod = $AP \times$ coefficient of linear expansion of metal.

$$\therefore 45 \times \cdot 00004 = AP \times 000060,$$

or

$$AP = 3 \text{ in.}$$

Therefore the length of the metal cylinder must be 6 in.

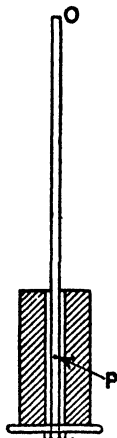

Fig. 31.

41. Harrison's gridiron pendulum (Fig. 32)

is a well-known form of compensated pendulum. It consists of four oblong frames arranged as shown in figure. The vertical rods are alternately of steel (S) and brass (B). The central steel rod passes through holes in the lower horizontal pieces of the frames, and carries the bob at its lower end. The arrangement is such that the steel rods expand downwards, while the brass rods expand upwards; and if the downward and upward expansions be equal, the centre of the bob is neither raised nor lowered.

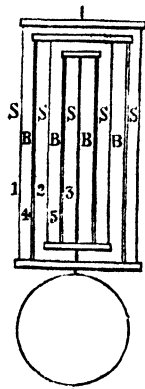

Fig. 32.

If it were possible to have the total length of each set of rods the same, only one metal would be required, but the inner rods must necessarily be shorter than the outer ones, and therefore, if compensation is to be exact, they must be made of the more expansive metal. The condition of compensation therefore requires that the total expansion of one set of rods should be equal to the total expansion

of the other, the rods being so arranged that these expansions take place in opposite directions.

Let L_0 denote the total effective* length at 0°C. of one set of rods, and L'_0 the total effective length of the other set; then—

$$L_t = L_0(1 + \alpha t), \text{ and } L'_t = L'_0(1 + \beta t),$$

where α and β are the corresponding coefficients of linear expansion. Hence, in one case, the expansion is given by—

$$L_t - L_0 = L'_0 \alpha t,$$

and in the other by—

$$L'_t - L'_0 = L'_0 \beta t.$$

For compensation we must have—

$$L_0 \alpha t = L'_0 \beta t, \text{ or } L_0 \alpha = L'_0 \beta, \text{ or } \frac{L_0}{L'_0} = \frac{\beta}{\alpha}.$$

That is, the total effective lengths of the rods in each set must be taken inversely proportional to the mean coefficient of expansion of the metals of which they are made. For steel and brass the ratio $\frac{\beta}{\alpha} = \frac{2}{3}$ nearly.

In some forms of Harrison's pendulum, *e.g.* that in the clock tower at Westminster, the rods are replaced by tubes one inside the other. This form is more compact than the open gridiron form.

42. Graham's mercurial pendulum (Fig. 33). The bob of this pendulum consists of a frame carrying two glass cylinders containing mercury. The principle of compensation is the same as that described above; the rod to which the bob is attached expands downwards, while the mercury expands upwards, and if the quantity is properly adjusted, the final result is

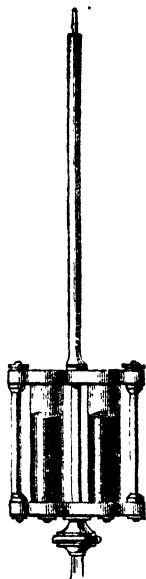

Fig. 33.

* It must be here noticed that the two vertical bars of each frame only effect the same expansion of the frame as one bar of the same length. Hence, in the figure, the effective length of the bars is $(1 + 2 + 3)$ for steel and $(4 + 5)$ for brass.

that the distance between the centres of oscillation and suspension is unchanged, and therefore the rate of the clock is unaffected by changes of temperature.

A calculation of the relative lengths of rod and mercury columns is given on p. 85.

43. In chronometers and watches the rate is controlled by balance wheels, which oscillate under the influence of a steel hair-spring. The time of oscillation increases if the dimensions are increased, and therefore a rise of temperature causes the rate of the watch to diminish. Further, a rise of temperature lessens the stiffness of the hair-spring, and this also tends to increase the time of oscillation, and diminish the rate of the watch.

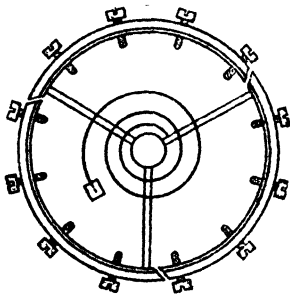

Fig. 34.

In chronometers and the best made watches, compensation is effected by making the circumference of the wheel of two metals, the outer being the more expansible. This double rim is made in three parts, each supported by an arm of the wheel (Fig. 34). The effect of rise of

temperature on this arrangement is, that while the end of segment of the rim nearest the supporting arm is pushed out from the centre by the expansion of that arm, the other end curls in towards the centre of the ring owing to the greater expansion of the outer strip of metal. By properly adjusting the screw weights, carried by each segment, exact compensation can thus be obtained.

44. **Invar.** M. Guillaume, a French metallurgist, has recently invented an alloy of nickel and steel containing 36% of nickel, whose coefficient of expansion (see Table, p. 54) is very nearly zero, whence its name Invar. It is very likely that the use of Invar will render obsolete all methods of compensating pendulums; Invar will also be employed for standards of length and capacity, and in all cases where

the expansion of a metal by rise of temperature introduces complications.

45. Force of expansion and its applications. The force exerted by a metal rod, if prevented from expanding or contracting as its temperature changes, is very great. For example, if an iron bar, of one square inch cross-section, is heated from 0° C. to 100° C., and then fixed, so as to prevent contraction, it will exert a force equal to the weight of about thirteen tons on the fixings. This may be illustrated by the simple apparatus shown in Fig. 35. The bar, A B,

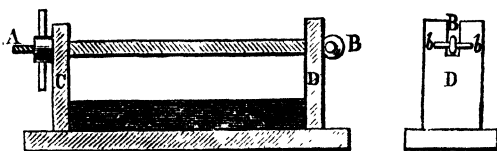

Fig. 35.

is held in position in a cast-iron frame, C D, by a short cast-iron rod, *b*, passing through the holes at the end B, outside the upright D. The bar is then heated by a lamp and the screw at the end A is tightened. The bar is then allowed to cool, and, up to a certain point, contraction is resisted by the cast-iron rod; finally, however, the stress becomes too great, and the rod is broken in two.

This contractile force of metals, due to fall of temperature, has many useful applications. The tyres of ordinary carriage and cart wheels are fitted on when red hot, and, on cooling, bind the wheels firmly together. Boiler plates are riveted with red-hot rivets, which, on cooling, draw the plates so close together that a steam-proof joint is formed. In cases where the walls of buildings have bulged outwards, they have been drawn in by passing iron bars through them, across the building, and attaching to their extremities, outside the building, iron plates screwed up to the wall with a nut. The bars are then heated, the nut and plate screwed up tightly against the wall, and the bar allowed to contract, drawing the walls with it. This pro-

cess is repeated, until the walls are made to assume their proper positions.

The expansion of a body due to heat may be sometimes turned to good account when a stopper of a glass bottle gets tight. Hold the neck of the bottle as close to a flame as possible. The neck gets hot before the stopper and owing to the expansion of the neck the stopper becomes loose. If the neck is held in the flame too long the stopper also becomes heated and things are as bad as before.

Some automatic fire alarms consist of an electric circuit containing an electric bell. The circuit is not closed at ordinary temperatures, but the break in the circuit is so arranged that when the temperature rises an expansion occurs in the metals adjoining the break and contact is made between the two parts of the circuit. The bell then rings.

46. Metallic thermometers. Thermometers based on expansion, have been constructed with metals. They are of little use as accurate instruments, but are convenient for giving an automatic record of the variation of temperature, and thus act as maximum and minimum thermometers.

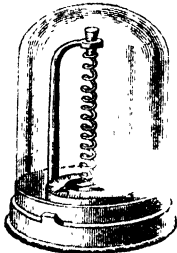

Fig. 36.

The best known instrument of this class is **Breguet's thermometer** (Fig. 36). If two strips of metal of different expansibility are riveted or soldered together and wound into a spiral with the most expansible metal inside, then any rise of temperature causes the inner strip to expand more than the outer, and consequently the spiral unwinds. Similarly, if the temperature falls, the spiral coils up. This thermometer is an application of this fact. It consists of a spiral composed of three metallic strips of silver, gold, and platinum, soldered together so as to form a single ribbon. The silver, which is the most expansible, is placed inside, the platinum outside, and the gold between serves to connect them. The spiral carries, at its lower end, a horizontal needle, which traverses a dial. As the spiral winds or unwinds with change of temperature, the needle is deflected in a corresponding direction, and indicates, by its motion, the variation of temperature.

This form of thermometer is employed in the common forms of recording thermometers or thermographs. The lever attached to the free end of the spiral carries a pencil which marks on a revolving drum.

Other metallic thermometers in which the change of electrical resistance with temperature is used to measure temperature will be described in Chapter XVIII.

47. Change of density with temperature. We have seen that, in general, when a body is heated it expands—that is, its volume increases—and, since the mass of the body remains constant, it must necessarily follow that its density decreases. For, if V_0 denote the volume at 0°C . and V_t the volume at t° , also if d_0 denote the density at 0°C . and d_t the density at $t^\circ\text{C}$., then—

$$V_0 d_0 = V_t d_t.$$

That is—

$$\frac{d_0}{d_t} = \frac{V_t}{V_0}.$$

But we know that $V_t = V_0(1 + ct)$, where c denotes the coefficient of volume expansion.

Therefore—

$$\frac{d_0}{d_t} = \frac{V_t}{V_0} = \frac{V_0(1 + ct)}{V_0} = 1 + ct,$$

or—

$$d_t = \frac{d_0}{1 + ct}.$$

This is true, as it stands, for solids, liquids, and gases; but for solids and some liquids we may have, *when t is small enough*, an approximate formula, giving—

$$d_t = \frac{d_0}{1 + ct} = d_0 \frac{1}{1 + ct} = d_0(1 - ct). \quad [\text{Art. 24, II.}]$$

Also corresponding to formula (2) of Art. 32 we have—

$$\frac{d_t}{d_t'} = \frac{V_t'}{V_t} = \frac{V_0(1 + ct')}{V_0(1 + ct)} = \frac{1 + ct'}{1 + ct} = 1 + c(t' - t).$$

The coefficient of expansion of a substance may thus be deduced from values of its density at different temperatures. This proves of great use in the case of liquids, for the density of a liquid is often more easily ascertainable than its volume.

EXERCISES IV.

Where the coefficients of expansion are not quoted use the table on p. 54.

1. Two rulers, the one of iron, and the other of brass, are placed one upon the other and riveted together so as to form a single ruler of two layers. At a temperature of 60° the compound ruler is straight. Describe and explain what occurs when it is successively exposed to a temperature of 30° and to a temperature of 100° .

2. The coefficient of linear expansion of brass is $0\cdot000019$. What will be the volume at 100° C. of a mass of brass the volume of which is exactly 1 cubic decimetre at 0° C. ?

3. The coefficient of linear expansion of brass is $0\cdot000018$. If a brass yard measure be correct at the temperature of melting ice, what will be its error at the temperature of boiling water ?

4. A light lath, a metre long can turn about a hinge at one end. A piece of wire two metres long is attached to the lath at a distance of one centimetre from the hinge. The wire is vertical and its upper end is fixed in such a way that the lath is horizontal. On heating the wire 50° C. the end of the lath sinks through 16 centimetres. Find the coefficient of linear expansion of the material of the wire.

5. A brass and a steel rod are each one metre long at 10° C. ; find the difference in their lengths at 60° C.

6. Suppose a substance has a coefficient of linear expansion $\cdot003$, would it be right to say that its coefficient of cubical expansion is exactly $\cdot009$? If not, why ?

7. The volume of a piece of glass at 100° C. is $100\cdot258$ c.c., and its volume at 0° C. is 100 c.c. Find the mean coefficient of cubical expansion of glass between 0° C. and 100° C., and thence deduce approximately the mean coefficient of linear expansion between the same limits of temperature.

8. A glass ball at temperature 40° C. is lowered into a vessel full of water at 40° C., and one pint of water overflows. Find what quantity will overflow if the same glass ball at temperature 100° C. is placed in a vessel full of water at 100° C. The coefficient of cubical expansion of glass is $\cdot000025$.

9. Find the mass of a cubic centimetre of silver at 250° C., the density of silver at 0° C. being $10\cdot31$ gm. per c.c.

10. Compare the densities of platinum and silver at 100° C., given that the densities of platinum and silver at 0° C. are $21\cdot500$ and $10\cdot570$ gm. per c.c. respectively.

CHAPTER V.

EXPANSION OF LIQUIDS.

48. Since a body of liquid or gas has no inherent shape but always takes up the shape of the vessel containing it, we cannot speak of a liquid or gas possessing a linear or a superficial expansion. We can deal only with cubical or volume expansion. And it is this expansion which is called *the* expansion of the liquid or the gas.

Having established in Exp. 2 that liquids expand on heating, it is of interest to find out whether, as in the case of solids, different liquids differ in expansibility. This point may be settled by a simple experiment.

Exp. 18. Fit up three exactly similar and equal flasks as for Exp. 2, and fix them in holes in a board (Fig. 37). Fill one with water, another with glycerine, the third with alcohol, and, by pushing the corks in more or less, adjust them so that the liquids rise to the same height in each tube. Then put them all into a vessel of warm water. The column of liquid in each tube will be observed to rise,* but the

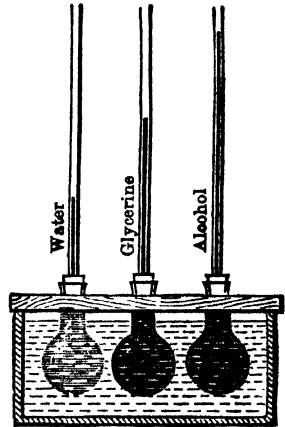

Fig. 37.

* If suddenly immersed in hot water the columns may suddenly sink at first. This is owing to the flasks expanding before the heat reaches the liquids.

amount of the rise will be different for each liquid. This indicates that each liquid is more expansible than glass, and also that the liquids differ between themselves in expansibility. The order of expansibility for the liquids chosen will be found to be water, glycerine, alcohol, the last being the most expansible.

49. Real and apparent expansion. When the expansion of a liquid is observed in a graduated containing vessel, the expansion which is *apparent*, or which may be observed, is the combined result of the *real expansion* of the liquid and the expansion of the containing vessel. If the liquid is more expansible than the material of the vessel it *appears* to expand, but if the liquid is less expansible than the vessel (as in the case of water between 4° C. and 6° C. in a glass vessel) it *appears* to contract, and if it were possible to find a liquid which expanded equally with the material of the vessel there would be no apparent expansion. The expansion of a liquid indicated or made *apparent* in a vessel initially graduated in equal divisions is known as the *apparent expansion* of the liquid in that vessel.

50. The mercury-in-glass thermometer. The graduation of an ordinary mercury thermometer is based upon the apparent expansion of mercury in glass. The degree divisions of the stem bore are all equal in volume *when the stem is all at one temperature*, but if the thermometer is heated from 0° C. to 100° C. the expansions for each degree rise of temperature, although *apparently* equal, really increase as the temperature rises.

As the thermometer is heated, say, from 0° C. to 1° C., the mercury must first expand so as to fill up the increase in the volume of the bulb and stem up to the 0° C. mark due to this rise of temperature, and then fill the degree division between the 0° C. and 1° C. marks at a temperature of 1° C. When the thermometer is heated, say, from 20° C. to 21° C., the mercury must first expand so as to fill the increase in the volume of the bulb and stem, not merely up to the 0° C. mark, but up to the 20° C. mark

for 1 degree rise of temperature, and then fill the degree division between the 20° C. and 21° C. marks, not at a temperature of 1° C., but at a temperature of 21° C. The real expansion corresponding to the degree rise of temperature from 20° C. to 21° C. is therefore greater than that corresponding to the degree rise of temperature from 0° C. to 1° C.

If, however, the volume of the bulb is large compared with that of the graduated stem, it may be assumed that the mercury has to expand the same amount per degree rise of temperature, that is that our scale of temperature depends upon the apparent expansion of mercury in a glass vessel, and other liquids are said to expand uniformly or not according as their apparent expansions in glass vessels are exactly proportional to those of mercury.

Recent work has shown that it is preferable to take our standards of temperature from a hydrogen thermometer (Art. 73), but since the expansion of mercury in a glass vessel is very nearly proportional at all ordinary temperatures to that of the expansion of hydrogen in a vessel of the same glass no harm results in adhering to the scale of temperature of a mercury thermometer in ordinary work.

Exp. 19. Find how the apparent expansion of water depends upon the temperature. Take the flask and tube containing water in Exp. 2 and immerse it in a mixture of ice and water. As the water in the flask cools the indicating column will be observed to fall for some time, then to become stationary for a few seconds, and finally to rise, showing that at a certain temperature water is at its maximum density, *i.e.* that if water at this temperature be either heated or cooled it will expand.

Reverse the experiment by withdrawing the now ice-cold flask from the ice and holding it in the air or in warm water. Observe that the temperature of maximum density is much nearer the freezing point than the boiling point.

Of course the above irregularity of expansion may be due to the glass and not to the water. If, however, the experiment is repeated with other liquids no such irregularity occurs; hence it must be due to the water.

51. Coefficient of real and apparent expansion. It was shown above that when a liquid contained in a vessel was heated the observed or *apparent* expansion was less than

the *real* expansion. To find the relation between the coefficients of real and apparent expansion of a liquid and the expansion of the solid composing the vessel, let us consider the case of a liquid contained in a glass vessel which was graduated at 0°C ., *i.e.* the volumes indicated by the graduations are correct at 0°C . Let V_0 = volume of liquid at 0°C ., V_a = the indicated volume at $t^{\circ}\text{C}$., and V_t = the true volume at this temperature. Let c_a , c_r be the apparent and real coefficients of expansion and g the coefficient of cubical expansion of the vessel.

The real expansion of the liquid = the product of the volume at 0°C ., the coefficient of real expansion, and the temperature, *i.e.*

$$V_t - V_0 = V_0 c_r t \dots\dots\dots(1)$$

Similarly the apparent expansion of the liquid is given by

$$V_a - V_0 = V_0 c_a t \dots\dots\dots(2)$$

The difference between them is the volume which a volume V_a of glass at 0°C . has expanded in being heated to $t^{\circ}\text{C}$. This is equal to $V_a g t$.

$$\begin{aligned} \therefore V_0 c_r t - V_0 c_a t &= V_a g t \\ &= V_0 (1 + c_a t) g t \quad (\text{from 2}) \end{aligned}$$

Dividing throughout by V_0 and t we get

$$c_r - c_a = (1 + c_a t) g.$$

Therefore neglecting $c_a t$, which is usually very small compared with unity, we get

$$\begin{aligned} c_r - c_a &= g \\ \text{i.e. } c_r &= c_a + g. \end{aligned}$$

That is—the mean coefficient of real expansion of a liquid is approximately equal to the sum of the mean coefficient of apparent expansion of the liquid in any vessel and the mean coefficient of volume expansion of that vessel.

The above applies directly to volume expansion, but it is also applicable to linear expansion. For instance, if a brass rod is measured by a steel scale (correct at 0°C .) at two temperatures the coefficient of real linear expansion of the brass can be found by adding to the coefficient of apparent linear expansion of the brass the coefficient of linear expansion of the steel.

It is an easy matter to find the coefficient of apparent expansion, but not so easy to find that of real expansion.

Now the coefficient of real expansion of mercury has been accurately measured in some classical experiments by Dulong and Petit, Regnault, and Callendar (Arts. 57, 58). Assuming the result (.0001815) which they have found for the range of temperature 0° C. to 100° C. and finding for ourselves the coefficient of apparent expansion of mercury in a glass vessel, we can deduce the coefficient of expansion of the vessel. Then if we measure the coefficient of apparent expansion of any other liquid in the same vessel, we can, by using the formula, calculate the coefficient of real expansion of the liquid.

52. Methods of finding the coefficient of apparent expansion of liquids. There are three easy methods:—

- (1) The Weight Thermometer method.
- (2) The Volume Dilatometer or Thermometric method.
- (3) The Hydrometric method.

53. The weight thermometer. In practice the weight thermometer method is simple.

Principle of the method: If a flask full of liquid at 0° C. is heated to t° C., some of the liquid overflows. Suppose m gm. overflow and M gm. remain. Then at 0° C. there were $(M + m)$ gm. in the flask, say M gm. below the mark B (Fig. 38) and m gm. above it.

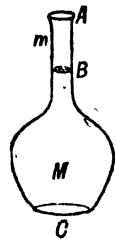

Fig. 38.

To find the coefficient of apparent expansion we assume that the capacity of the flask does not change with temperature. Then if V_0 is the volume of M gm. of liquid at 0° C. and V_t the apparent volume of M gm. of liquid at t° C., we have $V_0 =$ the volume of the flask up to B and $V_t =$ the volume up to A.

Hence
$$\frac{V_t}{V_0} = \frac{M + m}{M} \dots\dots\dots(3)$$

or
$$\frac{V_t - V_0}{V_0} = \frac{m}{M}.$$

Now by Art. 51

$$c_a = \frac{V_t - V_0}{V_0 t},$$

$$\therefore c_a = \frac{m}{M t} \dots\dots\dots(4)$$

$$\text{i.e. } c_a = \frac{\text{Mass of liquid expelled}}{\text{Mass left in at the higher temperature} \times \text{change in temperature}} \dots(4a)$$

The formula is also very nearly true when the lower temperature is not 0°C ., provided that t represents the actual change of temperature. If we wish to be more accurate let us denote the lower and upper temperatures by t_1° and $t_2^\circ \text{C}$.

Then

$$\frac{1 + c_a t_2}{1 + c_a t_1} = \frac{M + m}{M},$$

whence

$$c_a = \frac{m}{M(t_2 - t_1) - m t_1}.$$

The term $m t_1$ is usually very small in comparison with $M(t_2 - t_1)$, so that approximately

$$c_a = \frac{m}{M(t_2 - t_1)} \dots\dots\dots(5)$$

Practice of the method : This is best illustrated by an experiment.

Exp. 20. Make a weight thermometer and use it to find the coefficient of apparent expansion of mercury. Make



Fig. 39.

a glass vessel * 3 in. long of the form shown in Fig. 39 from a piece of clean and dry thin $\frac{1}{2}$ -inch glass tubing. The stem should have a fine bore, but should be strong enough to bear the weight of the thermometer when full of mercury. Weigh it. Placing all the apparatus on a mercury tray, support the tube in a wire-gauze basket, with the neck dipping under some hot mercury contained in a small dish (as illustrated). Fill the tube with clean and dry mercury by alternately heating and cooling. It is quite likely that the first two or three tubes will smash during this operation, but finally one will pass safely through the ordeal.

* Can be bought cheaply ready-made from instrument makers.

Place the tube, with its opening still under mercury, in the balance case with a Centigrade thermometer beside it. Leave for fifteen minutes. Then read the temperature t , and, hanging the tube upon the hook of the balance, quickly weigh it, taking care that no mercury oozes out through the opening in the meanwhile. (The balance case may conveniently be slightly cooled by placing a beaker of iced cold water in it during this operation.)

Now introduce the tube into a beaker of water so that only the narrow part projects outside; heat the water to boiling (100°C .), and keep it so for five or ten minutes. Note that mercury oozes out of the point. Do not waste this mercury: collect it and put it aside. Remove the tube carefully, wipe it, and cool it, taking care that no hot water enters the narrow neck as the mercury contracts on cooling. Reweigh. From the three weighings find

M , the mass of mercury left in the tube after heating to 100°C .,

m , the mass of mercury expelled during the heating from $t^{\circ}\text{C}$. to 100°C .; then

$$c_a = \frac{m}{M(100 - t)}$$

The mercury may be emptied out now and the experiment repeated with different liquids.

Example. A weight thermometer when empty weighed 5.913 gm., when full of mercury at 12°C . 61.755 gm., when full at 100°C . 61.022 gm. Find the coefficient of apparent expansion of mercury in glass and hence the coefficient of linear expansion of the glass.

$$m = 61.755 - 61.022 = .733 \text{ gm.},$$

$$M = 61.022 - 5.913 = 55.109 \text{ gm.},$$

$$t = 12^{\circ}\text{C}.;$$

$$\therefore c_a = \frac{m}{M(100 - t)} = \frac{.733}{55.109 \times 88} = .000151.$$

Regnault found that the coefficient of real expansion of mercury is .000181; hence the coefficient of volume expansion of the specimen of glass used in the given weight thermometer is given by

$$g = c_r - c_a = .000181 - .000151 = .000030.$$

Hence l , the coefficient of linear expansion of the glass = .000010.

Instead of weighing the tube before heating, the mercury that oozes out may be collected in a small beaker and weighed separately. By weighing such a small mass a more accurate value of m may be obtained than if m is obtained as a difference of two large masses. If this is done it is easy to start the experiment from 0°C .

Since by equation 5, Art. 53,

$$c_a = \frac{m}{M(t_2 - t_1)},$$

we have $t_2 - t_1 = \frac{m}{Mc_a}$;

hence if c_a be considered known the experiment described above might have been employed to determine the higher temperature if the lower one is known.

The weight thermometer can thus be used as a true thermometer; as such it has the great disadvantage that a weighing is necessary for the determination of each

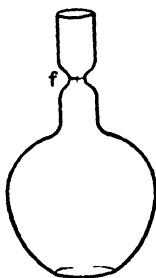

Fig. 40.

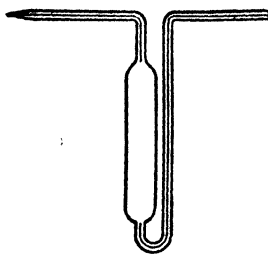

Fig. 41.

individual temperature. It may, however, be conveniently used as a maximum thermometer, for the value of t_2 given by the equations above always represents the maximum temperature experienced.

Other forms of the weight thermometer are the specific gravity bottle (Fig. 40) and the pyknometer (Fig. 41). These can be easily made from glass tubing, and have the merit of being easily cleaned and filled.

54. The volume dilatometer or thermometric method.

Principle of the method: A bulb is blown on a piece of very uniform thermometer tubing. The volume of the bulb and the cross section of the tube are found and the tube can then be graduated and the volume up to any graduation mark ascertained. The bulb and part of the stem are filled with a liquid and the volume of the liquid at 0° C. found. The dilatometer is then placed in a bath and its temperature raised. The temperatures at which the liquid column in the stem reaches the various marks is found. The increases of volume can thus be calculated and finally

$$c_a = \frac{\text{Increase of volume}}{\text{Volume at 0° C.} \times \text{change of temperature}}$$

This method is very suitable for liquids which evaporate readily.

Practice of the method: This is best illustrated by an experiment.

Exp 21. Make a volume dilatometer and use it to find the coefficient of expansion for water at various temperatures. Blow a bulb $1\frac{1}{2}$ in. in diameter on a piece of capillary tubing of $\frac{1}{16}$ in. bore and 20 in. long (Fig. 42). Make file marks along the stem at intervals of 2 inches. Measure the distances between the first and succeeding marks with a finely divided scale or vernier microscope. Weigh the dilatometer. Slightly warm the bulb, immerse the end of the stem in mercury and pick up a thread of mercury 6 or 7 in. long. Measure the length with a vernier microscope or a steel scale. Again weigh the dilatometer. The increase in weight divided by the density of mercury at the temperature of the observation gives the volume of mercury. This divided by the length of the column gives the mean cross section at the temperature of the observation of the portion of the tube occupied by the liquid column.



Fig. 42.

Expel the mercury by warming the tube and then fill

the tube with well-boiled distilled water. Arrange so that at ordinary temperatures the water column stands just below the first file mark nearest the bulb: clean and dry the outside and weigh. The increase in weight in grammes is equal the volume of the water in c.c. at the freezing point.* Measure the distances between the first and succeeding marks with a finely divided scale or vernier microscope. Immerse the bulb in a large beaker of water provided with a good thermometer and a stirrer. Adjust the source of heat (a small flame some distance below) so that the liquid surface remains at the first mark on the stem for several minutes, the water meanwhile being well stirred. Read the temperature. Similarly for second and succeeding marks up to temperatures of 95° C.

Tabulate and plot lengths against temperatures. The graph will not be straight; draw a fair curve through the points. Note it is concave upwards, showing that the coefficient of expansion is greater for higher temperatures. Find the mean length expanded per degree from 25° to 50°, 30° to 35°, etc., and then the coefficient of expansion between these temperatures.

Example. A volume dilatometer whose stem is uniformly graduated contains water. At 0° C. the level was at the 6th division. When heated to 10° C. it stood at the 7th division, and when heated to 20° C. at the 12th division. A thread of mercury occupying 24 stem divisions weighs .072 gm., and the quantity occupying the bulb and stem up to the zero division weighs 12.24 gm. Find the mean coefficient of expansion of water between 20° C. and 30° C.

The ratio of the volume of the space between two stem divisions to the volume of liquid at 0° C. is evidently .003 to 12.24, i.e. 1 to 4080. The volume at 0° C. is therefore 4086, the volume at 10° C. 4087, and the volume at 20° C. 4092, i.e. the expansion between 10° C. and 20° C. is 5 divisions. The mean coefficient of apparent expansion between 10° C. and 20° C. is therefore equal to

$$\frac{4092 - 4087}{4086 \times 10} = \frac{1}{8172} = .000122.$$

The coefficient of volume expansion of glass being taken as .000026 the coefficient of real expansion of water between 10° C. and 20° C. is $.000122 + .000026 = .000148$.

* Not exactly. It is the volume at 4° C., but scarcely any inaccuracy is introduced by taking it as at 0° C.

54a. Constant-volume dilatometers have been devised in which the volume of the bulb is kept constant by introducing into it just so much mercury that the expansion of the mercury is equal to the expansion of the glass bulb. The ratios of the coefficients of real expansion of mercury and that of glass being $\frac{.000181}{.000026}$ or as $\frac{7}{1}$, it is evident that if *one-seventh* of the bulb is filled with mercury the condition of constant volume is practically obtained.

55. Hydrometric method. If a body of density D weighs m_1 gm. in air and m_2 gm. in a liquid of density d we know that

$$\frac{m_1}{m_1 - m_2} d = D,$$

or

$$\frac{m_1}{m_1 - m_2} = \frac{D}{d}.$$

If therefore a body of invariable density D is weighed in a liquid at various temperatures we can from the variations of $(m_1 - m_2)$ find the variations of d .

Replacing the loss of weight $(m_1 - m_2)$ by w we have

$$\frac{w}{d} = \text{a constant or } \frac{w_1}{d_1} = \frac{w_2}{d_2}$$

where w_1, w_2 are the losses of weight at temperatures t_1°, t_2° when the liquid has densities d_1, d_2 . But

$$d_2 = \frac{d_1}{1 + c(t_2 - t_1)} \quad (\text{Art. 47})$$

$$\therefore \frac{w_1}{w_2} = 1 + c(t_2 - t_1).$$

In this expression since the density of the solid body is supposed to be constant, c is the coefficient of apparent expansion, and therefore we may write

$$c_a = \frac{w_1 - w_2}{w_2(t_2 - t_1)}.$$

Exp. 22. Make a bulb suitable for the determination of the expansion of a liquid by the hydrostatic method and use it to determine the apparent coefficient of a liquid. Take a piece of wide glass tubing (1 in. diam. say), draw out one end and round it off. Pour into the tube enough lead shot to make the bulb when completed sink in the liquid. Then draw off the other end of the tube at a point about 4 or 5 in. from the closed end and bend the soft glass into a hook to serve as an attachment (Fig. 43). The completed bulb should sink in the liquid whose coefficient of expansion you are going to measure. If it floats, shorten the bulb by drawing off more glass.

Now suspend the bulb from one arm of a balance by a long fibre or thin wire going through a hole in the base of the balance case so that the bulb is below the case. (The scale pan must be removed and the balance case mounted on an empty box lying on its side.) Counterpoise the bulb by weights placed in the other pan. Now support a large beaker of the liquid so that the bulb is wholly immersed. Leave for some minutes, stirring gently all the time, then again counterpoise and thus get the loss of weight at the particular temperature of the liquid. Repeat at two or three other temperatures.

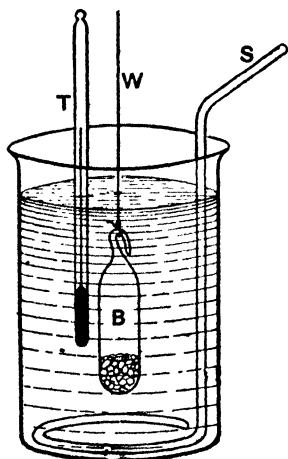

Fig. 43.

just then heavier, and with the balance arm free take the temperature when exact balance occurs. From the readings the apparent coefficient of expansion of the liquid can be obtained over several ranges of temperature.

Example. The loss of weight of a glass bulb immersed in water at 4°C . was $23\cdot26$ gm. ; at 74°C . it was $22\cdot74$ gm. Find the mean coefficient of apparent expansion of water between 4°C . and 74°C .

$$\frac{\text{Apparent density of water at } 4^{\circ}\text{C.}}{\text{Apparent density of water at } 74^{\circ}\text{C.}} = \frac{23\cdot26}{22\cdot74}$$

\therefore If c_a is the mean coefficient of apparent expansion of water between 4°C . and 74°C .

$$1 + 70 c_a = \frac{23\cdot26}{22\cdot74} = 1 + \frac{\cdot52}{22\cdot74}$$

$$\begin{aligned} \therefore c_a &= \frac{\cdot52}{70 \times 22\cdot74} \\ &= \cdot000327. \end{aligned}$$

Matthiessen performed a large number of experiments by this method, and used it to determine the coefficient of expansion of water at different temperatures. To get the coefficient of real expansion of the water it is of course necessary to know the coefficient of volume expansion of the solid used. He used a glass sinker in his experiments, and obtained its expansion by first determining its linear expansion and thence deducing its volume expansion.

56. Determination of the real expansion of mercury. The methods adopted, for the determination of this constant, by **Dulong and Petit** and by **Regnault**, were both based on the same principle, and differed only in experimental detail.

57. The method of Dulong and Petit. The principle of this method is simple. If we have two vertical tubes, communicating by a horizontal branch, and each containing a liquid of given density, the junction of the two fluids being in the horizontal branch, then, for equilibrium, the pressures due to the liquid columns on each side of a section, taken anywhere in the horizontal branch, must be equal.

Thus, consider the pressures on the section ab in Fig. 44. Let h and h' denote the depth of the centre of gravity of the section below the surfaces of the liquid in T and T' respectively. Then we have, from hydrostatical principles,

that the pressure on $a b$ due to the column in $T = h d g$,* and that due to the column in $T' = h' d' g$, where d and d' are the densities of the liquids in T and T' respectively, and g the acceleration due to gravity. But, since $a b$ is in equilibrium, we must have

$$h d g = h' d' g.$$

That is—

$$h d = h' d'.$$

It is evident that this is true whatever shape $a b$ may have, and whatever be the shape and size of T and T' .

If, now, the tubes contain mercury, and one column, T , be kept at 0°C ., while the other, T' , is raised to a temperature $t^\circ \text{C}$., we have—

$$h_0 d_0 = h_t d_t.$$

$$\therefore \frac{h_t}{h_0} = \frac{d_0}{d_t} = 1 + c_r t. \quad (\text{Art. 47.})$$

$$\therefore \frac{h_t}{h_0} - 1 = c_r t.$$

Or—

$$c_r = \frac{h_t - h_0}{h_0 t}.$$

Thus, the mean coefficient of real expansion can be determined by noting $(h_t - h_0)$, h_0 , and t , and the result is quite independent of the expansion of tubes containing the mercury.

The apparatus used by Dulong and Petit is shown in Fig. 45. The tube T' was enclosed in a cylinder, B , and surrounded with melting ice. T was placed in a thick copper cylinder, C , which was filled with oil; and, for the purpose of heating it, a furnace was built round it. This is shown in section in the figure. The temperature of this oil bath was given by two thermometers—a mercury weight thermometer, W , and an air thermometer, A . The air thermometer will be described in the next chapter; it is,

* See Wagstaff: *Properties of Matter*, § 210.

however, interesting to notice that this was the first time air was used as a thermometric substance to the exclusion of mercury. Dulong and Petit remarked that, at high temperatures, the indications of the two instruments did

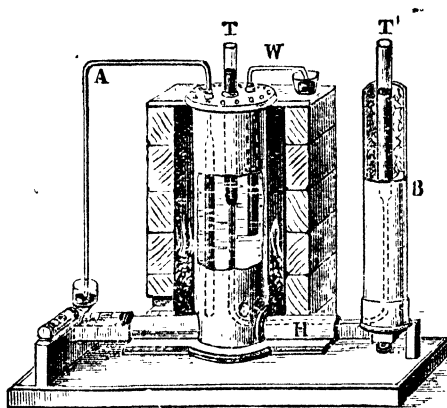

Fig. 45.

not agree; and so they decided to base their calculations on the indications of the air thermometer.*

The heights of the columns of mercury were read by means of the cathetometer, † which was invented expressly for this purpose. The level of the mercury in T was first

* It is important to notice that if Dulong and Petit had used only a *mercury* thermometer, they would not have detected any irregularity in the expansion of *mercury*.

† This instrument consists essentially of a vertical brass or steel scale, to which is attached a horizontally fixed telescope, capable of motion up and down the scale. To determine the vertical distance between any two points, the telescope is focussed on the higher point, and its position on the vertical scale read off. It is then lowered and focussed on the lower point, and the corresponding scale reading again taken. The difference of the two readings thus obtained gives the required vertical distance between the points. The telescope is furnished, in its field of view, with two fine cross wires at right angles to each other, and, in focussing, its position on the scale is so adjusted that the point viewed is made to coincide with the intersection of these cross wires.—(See Wagstaff: *Properties of Matter*, § 16.)

read, then the level in T', and finally the level of the *axis* of the horizontal tube, H. The difference of the first two readings on the cathetometer scale gave $h_t - h_0$, and the difference of the last two readings gave h_0 . The temperature t° C. of the oil bath, and therefore of the mercury in the tube T, was given by the air thermometer A. Thus all the data for calculating the mean coefficient of real expansion of mercury were determined.

The chief results obtained by Dulong and Petit were:—
The mean coefficient of real expansion of mercury

between 0° and 100°	$= 0\cdot0001818$;
,, 0° and 200°	$= 0\cdot0001843$;
,, 0° and 300°	$= 0\cdot0001887$.

This shows that the mercury expands faster at higher temperatures.

An error in this method is that heat may flow over from the hot to the cold tube, and thus the lower part of the mercury in the cold column may be heated to an unknown amount. In the next place, in order to make the top of the column of mercury rise about the heating apparatus, Dulong and Petit put a little cold mercury on the top of the hot column, thereby introducing an uncertainty as to its average temperature. Lastly, owing to the curvature of the surface the mercurial columns are subjected to a capillary pressure which is less as the temperature of the surface decreases. The difference in the lengths of the two columns is thus affected by this. These difficulties were overcome by Regnault.

58. Regnault's method. Regnault made a very careful determination of the real expansion of mercury by this method with a greatly improved form of apparatus, shown diagrammatically in Fig. 46. His first improvement on Dulong and Petit's apparatus was to connect the two vertical tubes, A C, F N (Fig. 46), near their upper ends by a horizontal tube, B G, at a point, O, along the top of which was made a fine pin-hole. Hence when the two tubes were filled with mercury the height to which the

mercury rose was limited by the fact that the superfluous quantity would escape from the pinhole, and since the globule formed there would be very strongly curved the mercury in the two tubes would stand at a slightly higher level than the pinhole.

When the two tubes, B C, G N, are at different temperatures the capillary pressure in the colder one being the greater forces some mercury across B G and thus increases the length of the projecting column of mercury in the hotter tube until the combined pressure due to capillarity and to the length of the columns of mercury is the same in both; hence the two columns B C and G N would be subjected to exactly the same pressure at B and G.

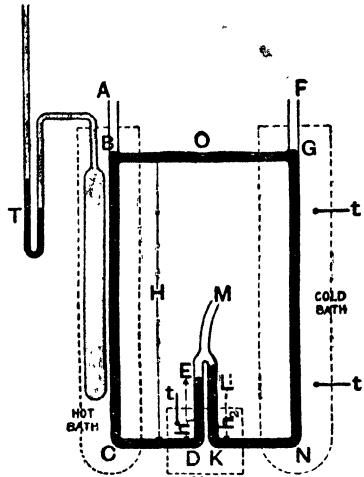

Fig. 46.

In the next place Regnault replaced the horizontal tube at the bottom of Dulong and Petit's apparatus by two bent tubes, C D E, N K L, terminating in a tube, M, which led to an air reservoir. Heat was thus prevented from flowing from the hot to the cold tube.

In carrying out an experiment mercury was poured in the tubes at A and F and pressure was applied to M to keep the mercury levels in D E and K L about half-way up the tubes.

When the mercury overflowed at O, the tubes were ready for heating. The dotted lines represent the heating and cooling baths, and B G was also cooled by cold water from the cold bath. Each bath was well provided with stirrers. The temperature of the hot bath was measured by an air thermometer, T, and that of the cold baths by mercury thermometers, *t*, *t*. As the heating proceeded,

the mercury level in *KL* rose above that in *DE*, showing that hot mercury is less dense than cold mercury. The vertical distances between the hole, *O*, and the centres of the tubes, *CD*, *NK*, and the heights of the columns, *DE*, *KL*, above the same centres, were now accurately measured.

Let *H* = height of *O* above the centre of the tubes, *CD*, *KN*; *h*₁, *h*₂ = heights of the columns, *DE*, *KL*, respectively from the same base line; *T*° C. = temperature of *BC*, and *d*, the density of the mercury at this temperature; *t*° C. = temperature of *GN*, *KL*, *DE*, and *d*_{*t*} the density of the mercury at this temperature.

Now, the air in *M* presses on the top of the columns in *DE*, *KL* with the same pressure, also the sum of the atmospheric and capillary pressures is the same at the points in the columns, *BC*, *GN*, on a level with *O*,

∴ the mercury pressure at *E* = mercury pressure at *L*,

$$\therefore Hd_{Tg} - h_1 d_{tg} = Hd_{tg} - h_2 d_{tg}$$

or

$$Hd_T = (H + h_1 - h_2) d_t.$$

Let *c*_{*r*} denote the coefficient of real expansion of mercury, then expressing the densities in terms of density at 0° C., viz. *d*₀, we get

$$\begin{aligned} \frac{H}{1 + c_r T} d_0 &= (H + h_1 - h_2) \frac{d_0}{1 + c_r t}, \\ \therefore 1 + c_r T &= \left(\frac{H}{H + h_1 - h_2} \right) (1 + c_r t). \end{aligned}$$

Now *c*_{*r*} *t* is small, hence in the term (1 + *c*_{*r*} *t*) Regnault could use Dulong and Petit's value of *c*_{*r*} without vitiating his result for *c*_{*r*} obtained by this formula.

The great advantage of this method is that the heights to be measured are in vertical lines near together, and so cathetometer errors are minimised.

Regnault made over 120 experiments between temperatures of 0° C. and 350° C. He plotted his results on a curve, and from the curve he calculated that the mean coefficient of real expansion of mercury between

$$0^\circ \text{C. and } 100^\circ \text{C.} = \cdot 0001815,$$

$$0^\circ \text{C. and } 200^\circ \text{C.} = \cdot 0001841,$$

$$0^\circ \text{C. and } 300^\circ \text{C.} = \cdot 0001866.$$

That is, if the temperature scale be derived from the air thermometer, the coefficient of expansion of mercury slightly increases with rise of temperature.

In such a case the expansion must be represented by the formula

$$V_t = V_0 (1 + at + bt^2 + ct^3)$$

instead of by the simple formula $V_t = V_0 (1 + c_r t)$. This suggested to Mendeleeff the use of the formula $V_t = \frac{V_0}{1 - kt}$ (which = $V_0 (1 + kt + k^2t^2 + k^3t^3)$) instead of $V_t = V_0 (1 + c_r t)$.

Callendar and Moss have recently repeated Regnault's experiment with improved devices. Regnault's mercury columns were about $1\frac{1}{2}$ metres high. By a simple device Callendar increased this to 6 metres, but still kept the apparatus compact. Platinum thermometers (Art. 265) were also used to measure the temperatures of the mercury columns. For the coefficient of expansion at any temperature Callendar obtained the formula

$$c_r = \left(1805553 + 12444 \frac{t}{100} + 2539 \frac{t^2}{100^2} \right) \times 10^{-10},$$

which for temperatures up to 200° C. may be reduced to the approximate form

$$c_r = (18056 + 2t) \times 10^{-8}.$$

Note that the mean coefficient of expansion from 0° to 100° is very approximately the actual coefficient at the average temperature 50° , viz. .00018156.

The increase in the coefficient of expansion of mercury with temperature is very small at ordinary temperatures, hence our justification for the use of the mercury thermometer in all ordinary work.

Exp. 23. Find the coefficient of real expansion of a liquid, say mercury, by a modification of Regnault's experiment. Take some $\frac{1}{4}$ inch glass tubing, clean it and dry it, and then bend it into two U tubes, A and B (Fig. 47), making the lengths as long as possible—2 feet if possible, but at any rate not less than 1 foot. Choose two suitable lengths of 1" glass tubing, fit them with corks, and bore the corks for the tubes and thermometers as shown. (If the thermometers may be tied on to A and B, no holes through the corks are required for them.) Also if ice-cold water and steam are to be used in the jackets no thermometers will be required. Carefully thread A and B through the corks, provide the side tubes and the

thermometers, and mount the whole on a wooden upright, or tie the tubes to two vertical retort stands. It will be necessary to provide some scales. If millimetre scales on slips of porcelain or glass mirror are to be had, tie them on to A and B. If not, place wooden millimetre scales vertically at the back of the large tubes, and a vertical looking-glass behind them, or the heights may be read by a cathetometer.

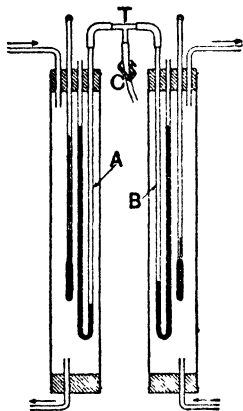

Fig. 47.

Pour clean mercury, little by little, into A and B. If any bubbles of air remain in the columns push a long wire down through and dislodge them. Connect the tops of A and B by thick rubber tubing to a glass T-piece, the remaining end of which communicates by another piece of thick tubing to a bicycle pump. This piece of tubing should be provided with a screw clip. Pump air into A and B until the mercury in one side of each is depressed nearly to the bottom, and the mercury in the other side elevated nearly to the top. Screw the clip tight. Read the differences of level of the two columns in A and the same in B. They should be equal, and should remain constant. If not equal the scales are at fault and must be readjusted. If the heights decrease there is a leakage and the rubber tubing must be tied on. Now pass cold water (ice-cold by preference) through B's jacket, and hot water (at a constant temperature, or steam, through A's jacket. The mercury gradually acquires the surrounding temperatures. When it has finished expanding read carefully the difference in levels h_2 , in A, and the difference in levels h_1 , in B.

Let t_2, t_1 be the temperatures of the hot and cold jackets, and d_2, d_1, d_0 the densities of mercury at these temperatures and at 0°C . Then equating pressures as before, we have

$$h_2 d_2 = h_1 d_1$$

$$h_2 \frac{d_0}{1 + c_r t_2} = h_1 \frac{d_0}{1 + c_r t_1},$$

$$\therefore h_2 + h_2 c_r t_1 = h_1 + h_1 c_r t_2,$$

$$\therefore c_r = \frac{h_2 - h_1}{h_1 t_2 - h_2 t_1}.$$

More accurate results will be obtained by this method in the case of liquids, such as petroleum and turpentine, which have a large coefficient of expansion.

MEAN COEFFICIENTS OF REAL EXPANSION OF LIQUIDS

between 0° C. and 40° C.

Mercury*	·000181	Turpentine	·00105
Water†	·000193	Ethyl alcohol...	·00108
Glycerine	·00053	Chloroform	·00140
Aniline	·00091	Carbon bisulphide	·00147
Petroleum	·00099	Ether	·00215

To make these figures comparable with those on p. 54, the former must be multiplied by 3, because they denote linear coefficients, and these refer to volume expansion.

Examples. (1) Find the coefficient of real expansion of mercury on the Fahrenheit scale.

The range, 1° F., is only $\frac{5}{9}$ of the range 1° C.

∴ coefficient of expansion on the F. scale = $\frac{5}{9} \times \cdot 00018 = \cdot 000101$.

It was proposed at one time to define the Fahrenheit degree to be such that the coefficient of real expansion of mercury on the F. scale was exactly ·00001.

(2) An alcohol thermometer is to be made from thermometer tubing of 1 mm. bore. Ten degrees of the temperature scale must occupy a length of about 2·5 cm. The bulb is to be spherical. What must be its internal radius?

Let r = radius of the bulb, then volume of bulb = $\frac{4}{3} \pi r^3$.

The expansion per 10 degrees is approximately equal to

$$\frac{4}{3} \pi r^3 \times 10 \times (\cdot 00108 - \cdot 00003),$$

and this must be equal to

$$\pi \times \left(\frac{1}{20}\right)^2 \times 2\cdot 5.$$

Therefore

$$\frac{4}{3} \times r^3 \times \cdot 0105 = \frac{1}{160}.$$

$$\therefore r = \sqrt[3]{\frac{1}{160} \times \frac{1}{\cdot 0105}} = \cdot 77 \text{ cm.}$$

The internal diameter of the bulb must therefore be about 1·5 cm..

(3) Determine the ratio between the height of the mercury in the glass vessels of a mercurial pendulum (p. 59) and the length of the steel rod in order that the distance between the top of the rod and the centre of mass of the mercury may be constant at all temperatures.

If the temperature rises from 0° C. to t° C. the volume of the mercury increases in the ratio $(1 + \cdot 000181t) : 1$ while the area of

* See pp. 80, 82, 83.

† The coefficient of expansion of water depends very much on the temperature. It increases rapidly as the temperature is raised. See pp. 87, 88.

cross section of the tube increases in the ratio $(1 + \cdot 000009 t)^2 : 1$. The height of the mercury in the vessel therefore increases in the ratio

$$\frac{1 + \cdot 000181 t}{(1 + \cdot 000009 t)^2} : 1, \text{ i.e. } 1 + (\cdot 000181 - \cdot 000018)t : 1 \text{ or } 1 \cdot 000163 t : 1.$$

If h is the height of mercury in the vessel at 0°C . then $h/2$ is the distance of its centre of mass from the bottom and $(h/2) \times 1 \cdot 000163 t$ is the distance at t° and $(h/2) \times \cdot 000163 t$ is the rise of the centre of mass of the mercury relative to the bottom of the tube.

If l is the length of the steel rod at 0°C ., $l \times \cdot 000012 t$ is the increase of length for $t^\circ \text{C}$. Therefore we must have for exact compensation

$$l \times \cdot 000012 t = (h/2) \times \cdot 000163 t$$

$$\text{or} \quad h = \frac{\cdot 000012}{\cdot 000081} \times l = \cdot 15 l \text{ about.}$$

59. Expansion of water. The expansion of water has been the subject of numerous experiments. It is of special interest, not only because water is so generally used in physical operations, but also because it presents noteworthy peculiarities. Amongst others, Pierre, Despretz, Hällstrom, and Mathiessen have studied this question; the first two used the ordinary dilatometer method, and the last two the hydrometric method. It is, however, most easily studied by using a constant volume dilatometer.

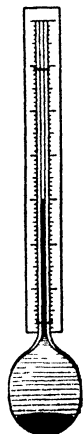

Fig. 48.

Exp. 24. Make a large constant volume dilatometer and study the expansion of water. On a piece of capillary tubing blow a large bulb. (It is better to blow the bulb on a piece of $\frac{1}{2}$ in. tubing, and seal a piece of capillary tubing* on to this.) Weigh the bulb, fill it with mercury and weigh again, and then empty out six-sevenths of the mercury, thus getting a constant volume dilatometer (Fig. 48). Find also the cross section of the capillary tube as in Exp. 21. Finally fill up with water to a convenient point in the stem. If the stem is graduated so much the better; if not tie a millimetre scale to

the stem.

Insert the bulb in a large bath of ice and water, provided with an accurate thermometer and a stirrer. Take the reading when the column is steady. Warm the water to 2°C . and keep it there

* The stem of a broken thermometer will serve the purpose well.

for ten minutes. Stir well and take the reading. Repeat for every 2° up to 10° C., and for every 5° up to 40° or above. Check the readings by letting the water cool again to zero. Add ice to

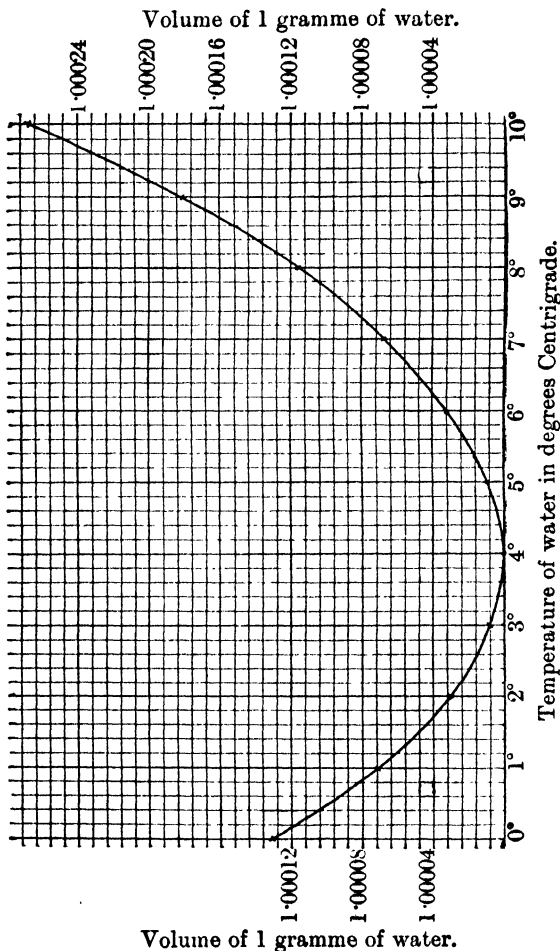

facilitate this. Take the mean of the two readings at any one temperature. Plot a curve, as in Fig. 49, showing how the reading varies with the temperature.

Note that as heating proceeds the column falls slowly and then very slowly until a temperature of 4°C . is reached. After this it rises, at first very slowly, and afterwards more rapidly, as long as the temperature is raised. At 4°C . therefore the volume is least i.e. water is at its greatest density at 4°C .

From the smoothed curve and the known dimensions of bulb and st. m, calculate the coefficient of *real* expansion of water between various temperatures. Taking the volume of 1 gramme of water at 4°C . as 1.0000 c.c., find the volume at other temperatures. Check your results by the following table:—

TABLE SHOWING THE DENSITY OF WATER AND THE VOLUME OF 1 GRAMME OF WATER AT VARIOUS TEMPERATURES

TEMPERATURE CENTIGRADE.	DENSITY.	VOLUME.
0° (ice)9169	1.0906
0° (water)999874	1.000127
1999930	1.000071
2999970	1.000030
3999993	1.000007
4	1.000000	1.000000
5999992	1.000008
6999970	1.000030
7999932	1.000068
8999881	1.000119
9999815	1.000185
10999736	1.000265
12999537	1.000464
14999287	1.000714
16998988	1.001013
18998642	1.001360
20998252	1.001751
25997098	1.002911
30995705	1.004314
35994098	1.005936
4099233	1.00733
4599035	1.00974
5098813	1.01201
5598579	1.01442
6098331	1.01697
6598067	1.01971
7097790	1.02260
7597495	1.02569
8097191	1.02890
8596876	1.03224
9096550	1.03574
9596212	1.03938
100 (water)95863	1.04315
100 (steam)000598	1672.5

With the volume dilatometer water can be lowered much below 0° C. before freezing sets in, and it has been found that expansion continually takes place on cooling until freezing does set in. Even -20° C. has been reached with liquid water. The slightest jar at this temperature, however, starts solidification and the temperature rises to 0° C.

60. Hope's experiment. Hope devised a simple experiment to determine approximately the temperature of maximum density. A tall glass jar, having two side openings fitted with thermometers, as shown in Fig. 50, is surrounded at its centre with an outer vessel containing a freezing mixture (Art. 118). The vessel is filled with water at the ordinary temperature, and allowed to cool under the influence of the freezing mixture. As cooling goes on, the lower thermometer falls steadily, while the upper one undergoes but little change; but as the temperature of the former approaches 4° C., it falls more and more slowly, and finally becomes stationary; meanwhile, the upper thermometer begins to fall more rapidly, and continues to do so until 0° C. is reached. Ultimately, a thin crust of ice begins to form on the surface of the water, and the lower thermometer remains stationary at 4° C.

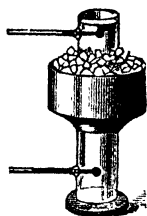

Fig. 50.

These facts admit of simple explanation. The freezing mixture cools the water nearest it, this contracts, becomes denser, and descends, causing the lower thermometer to fall rapidly. This goes on so long as a fall of temperature causes the water to contract, but below 4° C. expansion sets in, and then the water cooled by the freezing mixture rises instead of falls, and causes the rapid fall of the upper thermometer to 0° C., while the lower thermometer remains stationary at the temperature of the lowest, and therefore densest, layer; and its reading consequently indicates, approximately, the temperature of maximum density of water.

This experiment illustrates what actually takes place in

pools of water during frosty weather; the surface freezes, but the temperature of the deeper layers of water seldom falls below 4° C., and thus the lives of fish and other aquatic animals are preserved. It should be noticed here that water expands on freezing, and thus the ice floats on the surface. Were this not the case, each layer of ice would sink as it was formed, and ultimately all the water in the pools would be converted into ice.

Exp. 25. Fit up a tin can (instead of the glass jar above) and carry out Hope's experiment. As a freezing mixture use ice and salt.* Take readings every 10 minutes. Plot curves, with temperatures as ordinates and times as abscissae. The curve for the lower thermometer will show a long horizontal portion indicating a temperature very nearly 4° C.

Hope's experiment is merely qualitative, and does not give any accurate determination of the temperature of maximum density. The apparatus has, however, been slightly modified by Despretz, and made to yield accurate results. He employed four thermometers at different levels, and observed the temperature of each at regular intervals of time. He then drew a curve for each thermometer, showing its fall of temperature with time, and from the peculiarities of these curves he deduced, with some accuracy, the temperature of maximum density, for which he gives 3.98° C. as the mean value of his results.

61. Joule's experiment on the temperature of the maximum density of water. Dr. Joule adopted a method the principle of which is closely connected with that of Hope's experiment (see Art. 60). He employed a vessel consisting of two vertical tubes $4\frac{1}{2}$ ft. high and 6 in. in diameter, connected below by a tube fitted with a stop-cock, and communicating above by an open trough or channel (Fig. 51). The vessel was filled with water, so that there was free communication between the two tubes, both by upper and lower channels, when the stop-cock was open.

* If performed outdoors on a winter's day when the temperature is below 0° C. no freezing mixture is required.

To understand the method of experiment adopted with this apparatus, it must be remembered that, above and below the temperature of maximum density, temperatures can be found at which the density of water is equal—*e.g.* the density of water at 2° C. is nearly equal to its density at 6° C., for the mean of these temperatures is the temperature of maximum density. Joule, therefore, determined, with his apparatus, a series of temperatures at which water had the same density.

To do this the stop-cock was closed, and a light glass bead placed floating in the upper channel. The temperature of the water in each tube was now adjusted and the stop-cock opened; if the water in one tube was denser than that in the other it sank, and a current set up, through the stop-cock tube *from* the denser column and through the upper channel *towards* the denser column. This latter current carried the glass bead along with it, and hence the motion of this bead at once showed which tube contained the water of higher density. In this way the temperatures were adjusted until the glass bead remained stationary on opening the stop-cock; the mean of the temperatures of the water in each tube then gave the maximum density. By gradually diminishing the difference of temperature of the water in the tubes, Dr. Joule thus determined the temperature of maximum density of water to be 39.1° F. (3.95° C.) within a very small fraction of a degree.

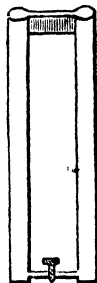

Fig. 51.

✓ **62. Barometric correction for temperature.** The pressure of the atmosphere is usually expressed in terms of the height of a column of mercury at 0° C. which exerts an equivalent pressure. The *observed* height of a barometer at t° C. has to be reduced to the *equivalent* height at 0° C.; this is called correcting for temperature, and in applying the correction two points are to be remembered: (i) To correct for the expansion of the scale between 0° C. and t° C.; (ii) To correct for the change of density of the mercury.

Let H denote the *observed* height of the barometer at $t^\circ\text{C}$. taken from the scale readings, H_0 the height that would have been observed if the whole instrument had been at 0°C ., l the mean coefficient of expansion of the scale, c_r the mean coefficient of real expansion of mercury, and t the temperature of observation. The scale readings are only correct at zero, therefore the true height, corrected for the expansion of the scale, is $H(1 + lt)$. Denote this by H_t . Then for (ii) we have, as in Art. 57, $H_t d_t = H_0 d_0$.

That is— $H(1 + lt) d_t = H_0 d_0$.

$$\therefore H_0 = H(1 + lt) \frac{d_t}{d_0}.$$

But $\frac{d_t}{d_0} = \frac{1}{1 + c_r t}$. (Art. 47.)

$$\therefore H_0 = H \frac{1 + lt}{1 + c_r t} = H [1 + (l - c_r) t].$$

Or, since c_r is usually greater than l , this is more generally written

$$H_0 = H [1 - (c_r - l) t].$$

It should be noticed that the mean coefficient of real expansion of mercury is employed because the correction (ii) is necessary on account of change of density of the mercury. *On no account must the column of mercury be treated as a rod subject to linear expansion.*

Example. A barometer with a glass scale reads 755.0 mm. at 18°C .; find the reading at 0°C . The coefficient of real expansion of mercury is .000182, and the mean coefficient of linear expansion of glass is .0000089.

Applying the above formula we have

$$\begin{aligned} H_0 &= 755 [1 - (.000182 - .000009) 18] \\ &= 755 [1 - .000173 \times 18] \\ &= 755 [1 - .0031] = 755 - 2.348 \\ &= 752.7 \text{ mm. nearly. } \checkmark \end{aligned}$$

EXERCISES V.

- ✓ 1. Distinguish between the absolute and the apparent expansion of a liquid, and show that the coefficient of absolute expansion is equal to the sum of the coefficient of apparent expansion and of the coefficient of expansion of the vessel.

2. The coefficient of absolute expansion of mercury being $\frac{1}{5550}$ and its coefficient of apparent expansion being $\frac{1}{3480}$, find the coefficient of volume expansion of glass.

3. A zinc rod is measured by means of a brass scale, and found to be 1.0001 metres long at 10°C . What is the real length of the rod at 0°C . and at 10°C .? [Mean coefficient of linear expansion of zinc is .000029 and of brass .000019.]

4. A rod of copper and a rod of iron placed side by side are riveted together at one end. The iron rod is 150 cm. long, and a mark is made on the copper rod, showing the position of the unriveted end of the iron at 0°C . If at 30° the mark is 0.0255 cm. from the end of the iron rod, what is the coefficient of expansion of copper, that of iron being 0.000012?

5. A weight thermometer when empty weighed 1.3210 gm. After filling it with mercury at 0°C ., and then heating it to 100°C ., .2351 gm. of mercury was expelled. The thermometer, with the residue of the mercury, when cooled down to the atmospheric temperature weighed 16.3075 gm. From these data calculate the coefficient of apparent expansion of mercury.

6. From the result in Question 5 and the known absolute coefficient of expansion of mercury (.0001815) calculate the coefficient of volume expansion of the glass.

7. The same thermometer as in Question 5, after filling with glycerine at 0° and then heating to 100°C ., expelled 0.0678 gm. of glycerine, and on cooling down it weighed 2.710 gm. If the coefficient of volume expansion of the glass is .000025, calculate the absolute coefficient of expansion of the glycerine.

8. A porcelain weight thermometer weighs 165 gm. when empty and 468 gm. when full of mercury at 0°C . When heated to 300°C ., the weight of overflow is found to be 13.464 gm. Find the mean coefficient of volume expansion of porcelain between 0° and 300°C ., assuming that of mercury to be .000184 for the same range of temperature.

9. An empty weight thermometer weighed 4.8155 gm. It was filled with water at 10°C . and gradually heated in a bath. At 20° , 40° , 60° , 80° , 95° it was withdrawn and weighed, the weights being 22.9032, 23.7966, 23.6340, 23.4220, and 23.2376 gm. Find the coefficient of real expansion between 20° and 40° , 40° and 60° , 60° and 80° , 80° and 95° . Draw a curve illustrating the change of coefficient of real expansion with temperature.

10. The coefficient of absolute expansion of mercury is .00018, the coefficient of linear expansion of glass is .000008. Mercury is placed in a graduated glass tube, and occupies 100 divisions of the tube. Through how many degrees must the temperature be raised to cause the mercury to occupy 101.56 divisions?

11. A mercury thermometer wholly immersed in boiling water reads 100°C . When the stem is withdrawn so that the graduations from 0° upwards are at an average temperature of 10° the reading is 98.6° . Find the coefficient of apparent expansion of mercury in glass.

12. A piece of glass weighs 47 gm. in air, 31.53 gm. in water at 4°C . and 31.75 gm. in water at 60°C . Find the mean coefficient of expansion of water between 4° and 60° , taking the coefficient of volume expansion of glass as 0.000024.

13. A solid weighs 29.9 gm. in a liquid of sp. gr. 1.21 at 10°C . It weighs 30.4 gm. in the same liquid at 95°C . when the sp. gr. of the liquid is 1.17. Calculate the coefficient of volume expansion of the solid, given that its mass in air = 45.6 gm.

14. In an experiment made with Dulong and Petit's apparatus to find the expansion of aniline, the column at 0°C . was 62.3 cm. high and the column at 100°C . was 5.67 cm. higher. Find the coefficient of real expansion of aniline.

15. In an experiment by Regnault's method for the determination of the absolute expansion of mercury, the following data were obtained: $H = 100$ cm. ; $h_1 = 12.4$ cm. ; $h_2 = 15.97$ cm. ; $t = 10^{\circ}\text{C}$. ; $T = 210^{\circ}\text{C}$. Find the value of c_r given by this experiment.

16. Water is said to have its maximum density at 4°C . Explain what this means.

In what respect is the behaviour of mercury different from that of water when both are gradually warmed from 0°C . ?

17. A barometer is provided with a silver scale which reads correctly at 0°C . What is the true height of the mercury corresponding to an apparent height of 761.05 mm. at 15°C . ? What height would the barometer register at 0°C . ?

CHAPTER VI.

EXPANSION OF GASES.

63. In Art. 8 it was shown by a simple form of apparatus (Fig. 4) that gases expand when heated; other simple pieces of apparatus which also illustrate the same fact are shown in Figs. 52, 53. Their construction is obvious; the liquid used may be mercury, alcohol coloured with magenta dye, or coloured sulphuric acid. To get the column of liquid in the tube warm the reservoir so as to expel some of the contained air, and on cooling dip the open end of the tube in the liquid. If the cork in B fits tightly a fine hole should be bored through it to enable the air within B to communicate freely with the atmosphere.

Exp. 26. Make one of the above pieces of apparatus, provide it with a home-made scale and observe its readings at different parts of the day, and at different days throughout the year. Compare its readings with those of a mercury thermometer fixed in its neighbourhood.

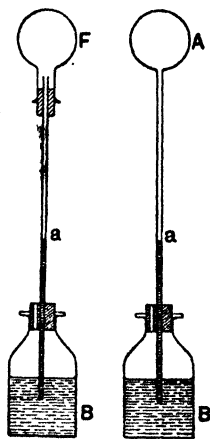

Fig. 52. Fig. 53.

Exp. 27. Take a long tube, fill it about three-quarters full with mercury, and measure the length of the air column still left in the tube. This air is at the atmospheric pressure. Now firmly close the tube with the thumb and invert the tube in a basin of mercury, as in making a barometer. Again measure the length of the air column. It is greater than before, i.e. the volume has increased.

Now the pressure of the air in the tube (*i.e.* the pressure on the air) is equal to the barometric height less the height of the mercury column in the tube. Read these two heights and find the difference. Show that

Barometric height \times former length of air column = difference between barometric height and height of mercury column \times final length of air column,

i.e. the product *pressure \times volume is a constant.*

This is an anticipatory proof of Boyle's Law.

From the above experiment we conclude that the volume of a given mass of gas depends upon its pressure as well as upon its temperature, hence in considering the expansion of gases by heat the effect of pressure must not be neglected.

64. The relation between the volume, temperature, and pressure of a gas. If experiments are to be carried out to find the relation between the volume, temperature, and pressure of a given mass of gas, it is obviously best to divide the experiments into three classes, and thus to find

(1) The relation between pressure and volume when the temperature is kept constant.

(2) The relation between volume and temperature when the pressure is kept constant.*

(3) The relation between pressure and temperature when the volume is kept constant.

We shall consider these separately in the following articles:—

65. The relation between pressure and volume: Boyle's Law. In 1662 Boyle stated that the volume of a given mass of gas is inversely proportional to the pressure when the temperature is kept constant. This may also be stated as follows:—The product of the pressure and the volume of a given mass of gas at constant temperature is constant, *i.e.*

$$P_1 V_1 = P_2 V_2 = \dots = \text{a constant} \dots\dots\dots(1)$$

* This is the simple case of expansion as already studied in the cases of solids and liquids.

Thus if the pressure is doubled the volume is halved; again, if the volume is to be increased threefold the pressure must be diminished to one-third its former value.

Exp. 28. To verify Boyle's Law experimentally in the case of air for pressures greater than that of the atmosphere. A piece of apparatus called Boyle's tube is generally used (Fig. 54). To make it, take a long piece (say 5 ft.) of stout glass tubing of about $\frac{1}{4}$ in. bore; clean and dry it, and then carefully heat one end and seal it. At about 12 in. from this end heat the tube and bend it through two right angles. Mount on a board and attach mm. scales to each limb, as in the figure, having the zeros at the same level and as low as possible. Insert a small funnel into the open end for the purpose of pouring in mercury. Take the apparatus into a corner of the room where the temperature will remain constant. As a check hang a thermometer near the short limb. Work over a mercury tray to catch spilt mercury.

Pour a little mercury into the bend and adjust by shaking until the mercury surfaces are both at zero. A certain mass of air has now been imprisoned in the short limb at atmospheric pressure. Read its volume, assuming the bore of the tube to be uniform, and taking the volume of unit length of tube as unit volume the number expressing the length of the tube may be regarded as the number expressing the volume.

Pour a little mercury into the long limb. Note that the mercury does not rise in the closed limb as rapidly as in the open limb: this is due to the enclosed air exerting pressure. Read the two levels. Pour in more mercury and repeat the readings. Proceed till the long tube is full.

Now read the barometer and note its height. The difference in level of the two surfaces in Boyle's tube plus

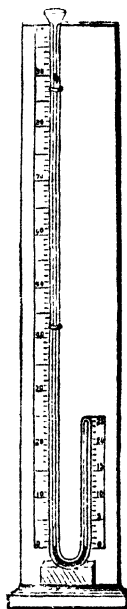

Fig. 54.

the barometric height is the total pressure exerted on the gas, and therefore exerted by the gas. The volume of the gas is found by subtracting the reading of the mercury surface in the closed limb from the reading of the top of the tube.* Enter the results thus :

Barometric height = 76 cm. Initial length of air column = 25 cm.

Ht. of Mercury in closed limb.	Ht. of Mercury in open limb.	Excess Pressure over Atmospheric = I. - II.	Total Pressure = Barometric Ht. + III.	Volume of Air deduced from I.	Product, Pressure \times Volume.
I.	II.	III.	IV.	V.	VI.
cm.	cm.	cm.	cm.		
0	0	0	76	25	1900
5	24	19	95	20	1900
10	61	51	127	15	1905
...

The products in Column VI. are practically constant: thus, Boyle's Law is verified.

To verify Boyle's Law for any gas it is only necessary to substitute that gas for air in the closed limb.

Example. Suppose 10 c. ft. of oxygen at atmospheric pressure (15 lb.-wt. per sq. in.) to be forced into a steel cylinder of 0.6 c. ft. capacity. Required the pressure of the gas in lb.-wt. per square inch.

Applying
we obtain

$$P_1 V_1 = P_2 V_2 ;$$

$$15 \times 10 = P_2 \times 0.6 ;$$

$$\therefore P_2 = 250 \text{ lb.-wt. per sq. in.}$$

A more satisfactory form of apparatus is shown in Fig. 55. V is a long graduated glass tube closed at one

* The tube being of uniform cross-section the volume of the air is proportional to the length of the column of air,

end. Its open end is tightly fitted with an indiarubber stopper, through which there is a glass T-piece, one arm of which communicates by a long piece of thick indiarubber tubing, I R, to an open reservoir, R, consisting of a piece of wide tubing, and the other carries a stopcock, C. The tube, V, may be fixed anywhere along the upright, P. The reservoir, R, can be raised or lowered by means of a string, S, passing over a pulley, W, fixed at the top of P. The mercury levels may be read by means of a millimetre scale attached to the front part of P.

The tap, C, being closed, V is removed from the board and mercury is poured in R until V and a large part of the tubing is filled. The tubing being tightly clipped, V is placed in position and R hung beside it. To the stopcock C is then attached a long drying tube, containing fused calcium chloride. R is then slightly lowered, and C being carefully opened, dry air rushes in and collects at the top of V. R is then carefully lowered until sufficient air has been collected in V, when C must be closed.

For experiments at a pressure greater than atmospheric, V should be near the bottom of the stand, and nearly full of air; for experiments at pressures less than atmospheric, V should be near the top of the stand, and about one-third to one-quarter full of air. To perform the experiment R is shifted to any part of the scale and the string then attached to a stud at the back of P. A short time is then allowed for things to come to rest; the mercury levels in V and R and the volume of air in V are then read. This is repeated for different positions of R, and the results are tabulated as before. A thermometer attached to V should indicate a constant temperature throughout the experiment,

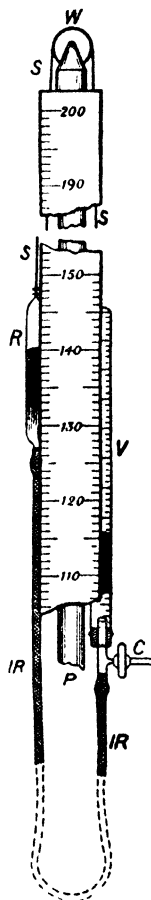

Fig. 55.

Exp. 29. Carry out an experiment with an apparatus like the above. A 50 c.c. burette furnished with a well ground and greased glass tap may be used instead of the closed glass tube V. The volume between the 50 c.c. mark and the tap must first be obtained. The open end is then drawn out to fit the indiarubber tubing, and the burette is fixed with the tap end uppermost and communicating to the drying-tube. By elevating R the burette is filled with

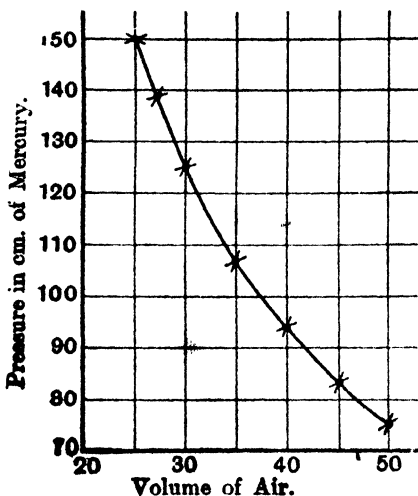

Fig. 56.

mercury, R is then lowered and the burette is filled with dry air.

Plot a curve between pressure and volume, pressures being ordinates and volumes abscissae. The curve will be like Fig. 56, which represents readings taken with a quantity of dry air which at a pressure of 75 cm. of mercury occupied 50 c.c. and which was compressed in six steps to half the volume.

Accurate results with a gas obeying Boyle's Law perfectly would give a rectangular hyperbola.* If the logarithm

* See a book on Conic Sections for the equation to a rectangular hyperbola.

of the pressure is plotted against the logarithm of the volume the result is a straight line, for since

$$P_1 V_1 = P_2 V_2 = P_3 V_3 = \dots \text{ a constant}$$

$$\log P_1 + \log V_1 = \log P_2 + \log V_2 = \log P_3 + \log V_3 = \dots$$

$$= \text{ a constant.}$$

Plotting therefore $\log P$ against $\log V$ we get a straight line. This straight line is inclined at 45° to either axis when $\log P$ and $\log V$ are plotted to the same scale (see

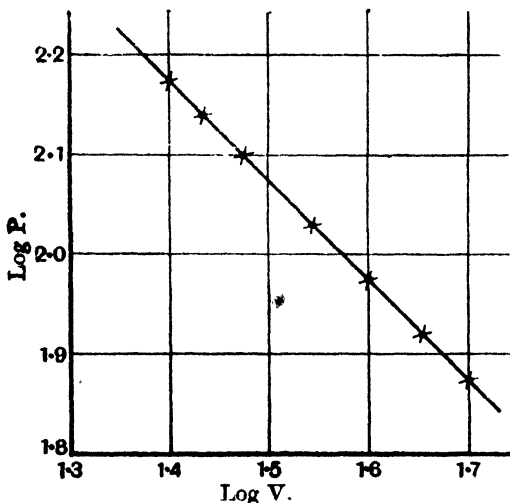

Fig. 57.

Fig. 57, which is obtained from the same data as Fig. 56). The logarithm diagram affords a better test of the accuracy of your results, for it is easy to see when a point is on or off a straight line, but not easy to see when it is on or off a hyperbola.

A curve which represents the relation between the pressure and volume of a body at constant temperature is called an **isothermal curve**.* We see that the isothermal of a gas like air is a rectangular hyperbola.

* Gk. *isos*, equal; *thermé*, heat; *thermos*, hot.

66. The relation between volume and temperature, when pressure remains constant. We have learnt that every solid or liquid has its own coefficient of expansion which is always a very small fraction. But all gases have nearly the *same* coefficient of expansion, which is *not* a very small fraction.

Exp. 30. To show that all gases have the same coefficient of expansion. Dry a pint flask, F (Fig. 58), fill it with dry air, and fit it with a cork carrying a stout and short delivery tube, D, leading into a collecting apparatus, A.* D should be clamped at C, so as to support F.

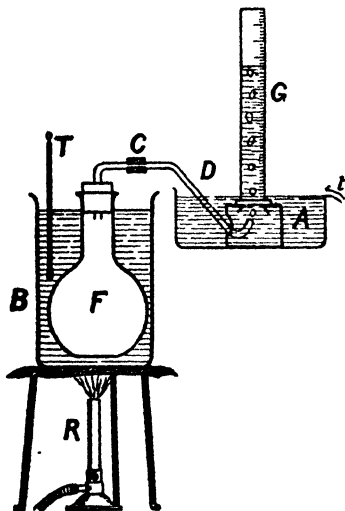

Fig. 58.

Take a large beaker, B, fix it in position, and fill it with water. Heat the water very slowly, stirring well, up to 20°C ., noting the temperature by a thermometer, T. When the temperature has reached 20°C . and bubbles have ceased to escape at the mouth of D, place over it an inverted graduated gas jar, G, of say 200 c.cm. capacity, which has been filled with water. Now heat B till the water boils,† and when the bubbles have ceased to rise note the volume of air collected. Then take the cork out of F and turn off the gas. The volume of air in G is the volume, measured at the temperature of the water in G, by which the quantity of air which filled F at a temperature of 20°C . is increased when heated to 100°C .

* This consists of a trough in which is placed a small cylinder, A, with a hole in one side, and another, provided with a conical flange opening inwards, through the top. The trough is filled with water till the cylinder is covered. The delivery tube is passed through the side hole and the gas passes up through the hole in the top.

† To prevent the water bumping as it boils, place a few fragments of unglazed earthenware (broken flower-pot) in the beaker. When boiling occurs, a continuous stream of bubbles of steam will come off from these fragments, the boiling being continuous and comparatively gentle.

Repeat the experiment, having previously filled F with coal-gas, hydrogen, or some other common gas. It will be found that the amount of gas which overflows into the measure is the same as was noted in the case of air.

The last experiment is more or less qualitative. The earliest accurate experiments were made by Dalton in England, and by Gay Lussac in France.

67. Gay Lussac's method of finding the coefficient of expansion of a gas at constant pressure. For the purpose of this determination Gay Lussac obtained a wide thermometer tube with a spherical reservoir and a long stem.

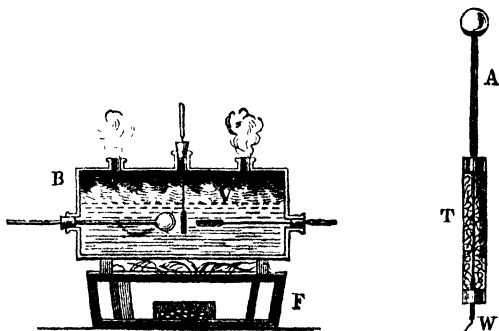

Fig. 59.

This tube he carefully calibrated and graduated after the plan mentioned in Art. 54. It was then filled with mercury and fitted, as at A, Fig. 59, into a wider tube, T, filled with calcium chloride.

By introducing a platinum wire, W, into the tube the mercury was slowly shaken out, and its place taken by air which was quite dry owing to it having passed over the calcium chloride in the wide tube. A short column of mercury was left in the stem of the tube to act as an index; it was then taken and placed horizontally (as at B, Fig. 59) in a sheet-iron vessel, V, which was first filled with melting ice and afterwards placed on a furnace, F, and gradually heated. The position of the mercury index was noted

when the bulb of the tube was surrounded with ice, and also at different temperatures as the heating went on.

From these observations the mean coefficient of *apparent* expansion of air in glass was calculated, and the mean coefficient of *absolute* expansion deduced, from this result and the known mean coefficient of expansion of the glass tube. It will be seen that this method is identical in principle with that of Art. 54. In this way Gay Lussac found the mean coefficient of absolute expansion of air at constant pressure (atmospheric) to be 0.00375 or $\frac{1}{268}$. This result we now know to be too high.

→ **Exp. 31. To find the mean coefficient of expansion of air at constant pressure.** Take a piece of tubing, A (Fig. 60), of uniform* bore (a piece about 2 feet long and $\frac{1}{8}$ inch in bore will do), carefully clean it and dry it, and seal up one end.

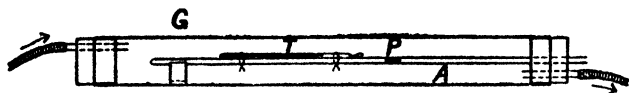

Fig. 60.

Heat the tube to over 100° C., and dip the open end in strong sulphuric acid.† As the tube cools acid will be forced up into it. Obtain in this way a thread of acid, P, about an inch or so in length. When the tube is cold the thread should be nearly halfway down the tube.

Fasten a thermometer, T, to the tube, and mount the tube by corks in a wide glass tube, G, so that the open end just projects, and then fix the outer tube horizontally, and provide it with corks, so that a current of water or vapour may be passed through it.

Pass a slow current of ice-cold water (0° C.) through G. By means of a metre scale measure as accurately as possible the distance between the closed end of the

* Test the uniformity.

† The great advantage of using strong sulphuric acid is that it is a strong absorbent of water vapour, and so it effectually dries the enclosed air. If the air were moist its expansion would be abnormally great.

tube and the near end of the thread. This length is proportional to the volume of the air at 0°C . Denote this volume by V_0 .

Now pass a steady current of steam through the tube. The air in A will expand and force the thread outwards. This expansion will occur at atmospheric pressure; for the other side of the thread is exposed to the atmosphere. When the thread becomes stationary note again the position of the near end. Denote the volume of the air at 100°C . by V_{100} .

Then c_a , the mean coefficient of apparent expansion of air in glass at constant pressure between 0°C . and 100°C ., is given by

$$\frac{V_{100} - V_0}{100 \cdot V_0}$$

and c_r , the mean coefficient of real expansion of air in glass by

$$c_r = c_a + c = c_a + \cdot 000025.$$

Since c_a is much larger than c , and the above experiment is only rough, it is not worth while correcting for the expansion of the vessel.

The above coefficient is the mean coefficient between 0°C . and 100°C .

68. Regnault's method of finding the coefficient of expansion of gas at constant pressure. In Gay Lussac's method there are two important sources of error. (a) The moisture clinging to the interior of the thermometer tube was not removed, and, as it was converted into vapour on heating, the volume of the enclosed air appeared to increase more than it really did, hence the result obtained was too high. (b) The index of mercury in the stem did not completely separate the enclosed air from the outer air.

Regnault modified his apparatus so as to avoid these errors; the interior of the vessel which contained the gas was thoroughly dried by alternately filling it with dry warm gas and exhausting it by means of an air pump, and the mercury index in the stem was replaced by a long column of mercury in a U tube (or manometer). His apparatus

is shown in Fig. 61. The reservoir A, in which the gas is placed, is a small spherical vessel which can be enclosed in a suitable metal vessel, M, and the temperature of the contained gas adjusted by filling the space between the two with ice, water, steam, etc.

The manometer, BCDE, consists essentially of two vertical tubes communicating below by a metal bend to which a tap is attached. In order to keep it at a uniform

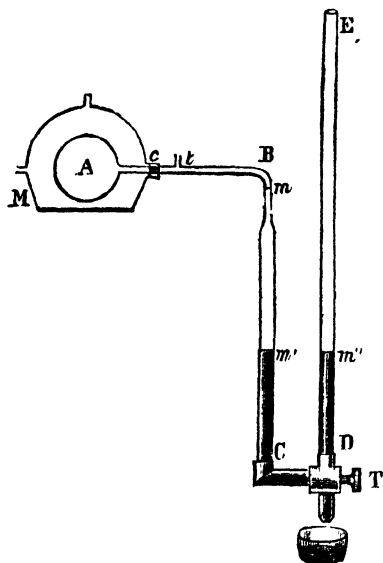

Fig. 61.

and known temperature it is immersed in a water bath, not shown in the figure. One of the tubes, BC, ends in a fine piece of tubing which is bent over at B and joined to the stem of A; the other, DE, is much higher. Communicating with the horizontal part between B and A is a small tube, *t*, by means of which the interior of A is dried, and the gas introduced into it after passing through a series of drying tubes.

To perform the experiment the reservoir, A, is surrounded with melting ice, and mercury is poured into the manometer at E until it rises to the mark *m* on the tube, BC, and to a point in DE on the same horizontal line as *m*. This adjustment of levels is readily effected by varying, through *t*, the quantity of air in A. The tube *t* is now sealed off in the blow-pipe, the ice in M removed, and a small quantity of water put in its place and heated till it boils.

The reservoir A is thus surrounded with steam at the temperature of the boiling point; the contained gas

expands, and, depressing the column of mercury in B C, causes that in D E to rise. The tap T is then opened and some mercury run out, the level in D E falling more rapidly than that in B C. As the gas further expands more and more mercury is run out, and when the expansion is complete the levels of the mercury columns in B C and D E are adjusted in the same horizontal line in a position similar to that shown in the figure at m' , m'' .

The air in A has thus expanded, between 0° C. and t° C., at a constant pressure equal to that of the atmosphere at the time of the experiment,* for, both at 0° C. and t° C., the mercury columns in the manometer have been adjusted so as to have no difference of level. If, then, we know the relative volumes of A, of its stem up to m , and of the portion of B C between m and m' , we can calculate the mean coefficient of absolute expansion in the usual way.

It must be noticed here that the gas in the part of the apparatus outside M is at a different temperature to that in A, hence a correction for this as well as for the expansion of the glass must be applied in working out the result.

Thus, for example, let the initial temperatures of the reservoir and manometer be 0° C. and the final temperatures T° C. and t° C. Also let V_0 and v_0 be the volumes of the reservoir and the space $m m'$ at 0° .† Then the initial volume of the air at 0° C. is V_0 , and the volume of the air if all were at T° C. would be

$$V_0(1 + cT) + v(1 + ct) \left(\frac{1 + c_r T}{1 + c_r t} \right),$$

where c_r is the coefficient of real expansion of air at constant pressure and c is the coefficient of volume expansion of glass.

But this must be equal to

$$V_0(1 + c_r T),$$

$$\therefore V_0(1 + c_r T) = V_0(1 + cT) + v(1 + ct) \left(\frac{1 + c_r T}{1 + c_r t} \right),$$

from which c_r may be calculated.

* If the atmospheric pressure has not remained constant, allowance must be made for this in adjusting the mercury levels at the finish of the experiment.

† V_0 includes the portion of the capillary tube included within the heater, and v_0 includes that portion kept at the temperature of the manometer.

Regnault found by this method the value 0.0036706 for the mean coefficient of absolute expansion of air at atmospheric pressure between the freezing and boiling points of water. For different gases the value of this coefficient varied slightly, especially in the case of gases which are easily liquefied. Practically, however, this result, which is approximately equal to $\frac{1}{273}$, may be considered as applicable to most gases.

Exp. 32. To show that the expansion of air is uniform. Modify the apparatus of Exp. 31 by bending up the end of the tube and using a long metal water bath, as in Fig. 62. Bind several pieces of copper around the tube at various distances from the closed end. Heat slowly, stir well, and

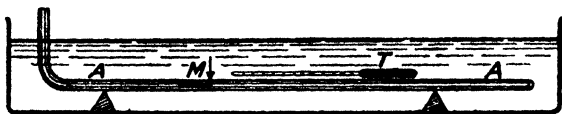

Fig. 62.

take the temperatures as the inner end of the liquid column arrives at the wire marks. The temperature should be kept constant for a minute or two before taking the reading. Finally measure the distances of the wire marks from the closed end of the tube. Tabulate and plot lengths and temperatures. The graph is practically straight, showing that the expansion is uniform. Deduce from the graph the value of c_a .

Example. In an experiment like the above with a tube of very uniform bore, wires were tied around at distances of 36, 38, 40, 42, etc., cm. from the closed end of the tube. The experiment was begun at 0°C ., when the near end of the column was between the first and second wires. The temperatures at which it arrived at the other wires were 14°C ., 29°C ., 44°C ., 58°C ., 74°C ., 88°C .. On boiling it did not reach the eighth wire.

Plot the curve (Fig. 63). It is practically straight. Deduce from it that V_0 , given by the point A, = 36.0 cm., and V_{100} , given by the

point B, = 49.5 cm., and hence that the coefficient of apparent expansion of air in glass at constant pressure

$$= \frac{49.5 - 36.0}{36 \times 100} = \frac{13.5}{3600} = .00375.$$

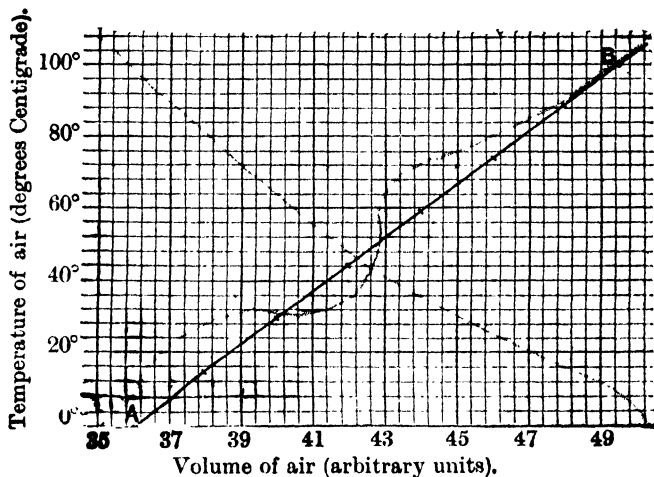

Fig. 63.

69. Another method of measurement of the coefficient of expansion of air at constant pressure. The principle of the weight thermometer may be applied to determine the coefficient of expansion of air at constant pressure. The weight thermometer after being filled with dry air is heated, say, to 100°C . with the open end of the neck just dipping under mercury in a dish. When no more air is expelled the thermometer (and mercury) is cooled to 0°C . and mercury flows into the tube. The pressure of the air remaining in the thermometer is then adjusted to that of the atmosphere, the mouth of the thermometer closed with the finger, and the thermometer withdrawn from the mercury in the dish. It is then weighed. From this weight and the weight of the empty tube the weight of mercury now in the tube can be found. Let it be m gm. The thermometer is now filled with mercury at 0°C . and

weighed again. Let the weight of the mercury which fills the tube at 0°C . be M . Then we have

$$\frac{\text{Volume of air which fills the thermometer at } 100^{\circ}\text{C.}}{\text{Volume of the same quantity of air at } 0^{\circ}\text{C.}} = \frac{M}{M - m}$$

$$\therefore 1 + 100 c_a = \frac{M}{M - m} = 1 + \frac{m}{M - m}$$

$$\therefore c_a = \frac{m}{100(M - m)}$$

If the temperatures are $t_1^{\circ}\text{C}$. and $t_2^{\circ}\text{C}$. instead of 0°C . and 100°C . we have

$$\frac{1 + c_a t_2}{1 + c_a t_1} = \frac{M}{M - m}$$

whence

$$c_a = \frac{m}{M(t_2 - t_1) + m t_1}$$

Exp. 33. Find the coefficient of expansion of air at constant pressure. (The experiment is much more easily performed if water is used to fill the bulb instead of mercury.

The results are not quite as accurate, but at this stage it is more important to grasp principles than to get accurate results.)

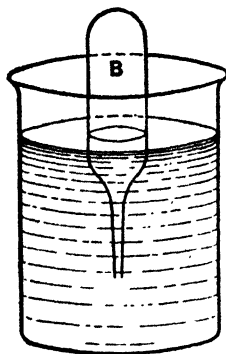

Fig. 64.

Make a bulb B (Fig. 64) from a piece of glass tubing or a boiling tube; the neck should be drawn out very narrow. Care should be taken that none of the condensed water from the gas flame gets into the tube. Weigh the bulb. Fix the bulb, with tube upwards, in a clamp so that as much of it as is possible is immersed in water placed in a large beaker. Boil the water and take its temperature, $t_2^{\circ}\text{C}$., say.

After about ten minutes of boiling bring a blow-pipe flame to the open end of the neck and seal it. Now take the bulb, invert it in cold water in a large beaker (Fig. 64) and break off the tip of the neck with a pair of forceps,

The water rises within the bulb. Support the bulb in a clamp so as not to warm it with the hands, adjust its level till the water within is level with the water without and leave it for five minutes to acquire the temperature of the water. Read this temperature, $t_1^\circ \text{C.}$, say. Finally adjust the bulb to get the water levels the same, and then quickly close the mouth of the neck with the finger or a bit of plugged rubber tubing, and reinvert the bulb. Dry the outside and weigh the bulb (including the fragment broken off). Now fill the bulb with water, adjust the temperature of the water to $t_1^\circ \text{C.}$ before withdrawing the neck of the bulb. Dry and weigh again. Work out the results as in the following example.

Example. In an experiment as described above the weight of the bulb was 7.14 gm., weight when partly filled with water at 9°C. was 14.67 gm., weight when filled with water at 9°C. was 37.35 gm. The boiling water was at a temperature of 101°C. Find the coeff. of expansion of air at constant pressure.

We have (neglecting the effects of water vapour),

$$\frac{\text{Volume of air filling bulb at } 101^\circ \text{C.}}{\text{Volume of same air at } 9^\circ \text{C.}} = \frac{37.35 - 7.14}{37.35 - 14.67} = \frac{30.21}{22.68'}$$

$$\therefore \frac{92 c_a}{1 + 9 c_a} = \frac{7.53}{22.68'}$$

$$\therefore c_a = .0037.$$

70. Dalton's, Gay Lussac's, or Charles's law. The facts that air and other gases expanded uniformly when heated at constant pressure were first discovered, as mentioned above, by John Dalton, the author of the atomic theory, and afterwards verified by Gay Lussac, and more accurately by Regnault, and their formular expression is known as Dalton's, or Gay Lussac's, or Charles's Law. It may thus be enunciated:—

The coefficient of expansion of any gas under constant pressure is $\frac{1}{273}$, or

If the temperature of any given mass of gas, whose pressure is maintained constant, be raised 1°C. , the volume increases by $\frac{1}{273}$ of the volume it would have at 0°C. under the same pressure,

$$\text{i.e. } V_t = V_0 (1 + c_r t) \dots \dots \dots (2)$$

where V_0 = the volume at 0°C ., V_t = the volume at $t^\circ \text{C}$. of the same mass of gas, and $c_r = \frac{1}{273}$.

Also

$$V_{t_1} = V_0 (1 + c_r t_1),$$

$$\therefore \frac{V_{t_1}}{V_t} = \frac{1 + c_r t_1}{1 + c_r t} \dots\dots\dots(8)$$

a useful relation.

In the case of Regnault's experiments the pressures used were in the neighbourhood of the atmospheric pressure, but of course by using higher pressures we may determine the coefficient of expansion of the gas in a state of greater density. It is found that the coefficient slightly increases as the pressure increases. In the case of air the true c_r is given by $c_r = \cdot 0036605 + \cdot 00781\rho$, where ρ is the density. In Regnault's experiments $\rho = \cdot 001293$ gm. per c.c.

The coefficient of expansion also varies with the temperature, very little at ordinary and high temperatures, but considerably at low temperatures, especially when the gas is approaching its temperature of liquefaction.

71. Relation between the temperature and the pressure of gases when the volume is constant. When a gas is heated in a closed vessel so that it cannot expand it is obvious from our previous knowledge that its *pressure* must increase. We now proceed to find out how it increases in the case of air.

Exp. 34. To find the coefficient of increase of pressure of air at constant volume. Fit up an apparatus as shown in Fig. 65. A is a bulb (2 to 3 in. in diameter) full of dry air, attached by a stout narrow tube B C D (of $\frac{1}{8}$ " bore), bent twice at right angles, to a long piece of stout indiarubber tubing, D E F, in the other end of which is thrust a straight bit of open glass tubing, F G. By means of clamps D C is attached to an upright stand, M, and then D E F is filled with mercury so that the mercury rises into D C and F G. F G is attached to a sliding piece, K, which can be fastened at any height by means of a screw-clamp, S. A millimetre scale is pasted on to the front of M, and levelling screws, L, L, L, serve to set M vertical.

Take a large beaker, half fill it with cold water and lumps of ice, and fix it so that A is wholly submerged. The temperature of A gradually arrives at 0°C . Adjust K so that the mercury surface in CD reaches a convenient point, o , as near the bulb as possible.* Read the level of the mercury surface, p , in GF and the height of the barometer. If this is H, then P_0 , the pressure of the air in A, = \bar{H} plus the difference in levels of o and p if p is above o , or H minus the difference in levels if p is below o .

Now put a burner underneath the beaker and heat the water. As the temperature rises the air in A will expand and force the mercury in CD down. Prevent this by lifting up GF so that the mercury is forced back to o . Proceed till the temperature is nearly 20°C ., then turn the burner down and keep the bath at 20°C . for some time. When things are steady finally adjust K till the mercury is exactly at o , and then read the height of the mercury surface in GF and the barometer. Deduce the pressure at 20°C ., in the same way as P_0 was deduced. Now proceed to temperatures of 40°C ., 60°C ., 80°C ., and 100°C . (boiling), and repeat the observations. Tabulate the results.

Plot a curve taking temperatures as abscissae and pressures as ordinates. The result will be a straight line, showing that the pressure increases uniformly with temperature

i.e. $\frac{P_{100} - P_0}{100 \cdot P_0}$, or in general $\frac{P_t - P_0}{P_0 t}$ is a constant.

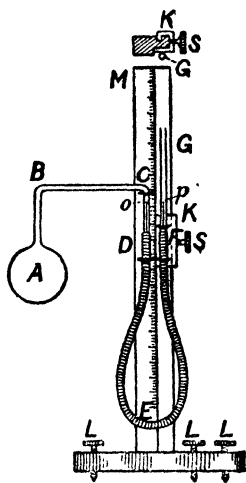

Fig. 65.

* If the apparatus has not previously been set up this may be managed by filling the indiarubber tubing with mercury before slipping it on to the tube, CD. A being previously at the air temperature the mercury will rise up DC as A is cooled to 0°C .

If the experiment is performed carefully, it will be found that this constant is also equal to $\frac{1}{273}$.

Example. The following table shows a set of results which may be obtained :—

Temperature.	Pressure.	Increase of Pressure above 760 mm.	Increase of Pressure per degree rise above 0° C.
0° C.	760 mm.	—	—
21° C.	818 mm.	58 mm.	$\frac{58}{21}$ or 2·76 mm.
32° C.	849 mm.	89 mm.	$\frac{89}{32}$ or 2·78 mm.
54° C.	910 mm.	150 mm.	$\frac{150}{54}$ or 2·78 mm.
75° C.	968 mm.	208 mm.	$\frac{208}{75}$ or 2·77 mm.
100° C.	1038 mm.	278 mm.	$\frac{278}{100}$ or 2·78 mm.

The mean of the last column = 2·78,

$$\therefore \text{the coefficient of increase of pressure} = \frac{2\cdot78}{760} = \frac{1}{274}.$$

The above experiment leads us to write

$$P_t = P_0 (1 + c_{ap}t),$$

where c_{ap} is the coefficient of increase of pressure at constant volume uncorrected for the expansion of the vessel, and t is the temperature Centigrade. We see that c_{ap} is approximately $\frac{1}{274}$.

The correction for the expansion of the bulb may be applied in the usual manner. Thus if c_p is the coefficient of real increase of pressure at constant volume,

$$c_p = c_{ap} + c,$$

but c is so small that as a rule it is smaller than the probable error in c_{ap} , hence the correction is negligible.

Exp. 35. To prove that the coefficient of increase of pressure is the same for all gases. Take a long piece of glass tubing, bend it as shown in Fig. 66 (which is a perspective view) and suck up some mercury or strong sulphuric acid to act as a pressure gauge in the U tube. Put the ends of the tubes through two rubber corks, which are of such a size as to fit tightly into two flasks, A and B (which need not be of the same size).

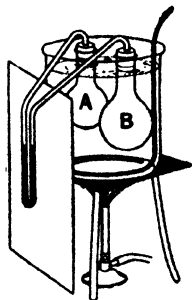

Fig. 66.

By passing a continuous stream of a gas, say coal gas, by means of a tube through the flask A for some time it may be filled with coal gas to the exclusion of any other gas. Similarly fill B with any other gas or let it remain full of air. Place the flasks side by side in a big beaker and fill the beaker with water (the clamps required are not shown in the figure). Push the corks into the flasks. The levels of the liquid in the two sides of the gauge should now be the same.

Heat the water to boiling, meanwhile inserting a screen between the gauge and the beaker. Observe that *the liquid in the gauge is undisturbed*. But we know by former experiments that the pressures in the two flasks must have increased; we therefore now deduce that they have increased by the same amounts, i.e. the coefficient of increase of pressure is the same for coal gas as for air. The same holds for most gases.

Summing up the results of the last two experiments we get the following law:—

The Law of Pressures.—If the temperature of any given mass of gas, whose volume is kept constant, be increased 1°C . the pressure is increased by $\frac{1}{273}$ of the pressure at 0°C .

i.e. $P_t = P_0 (1 + c_p t)$ where $c_p = \frac{1}{273}$(4)

Also $P_{t_1} = P_0 (1 + c_p t_1)$,

$$\therefore \frac{P_{t_1}}{P_t} = \frac{1 + c_p t_1}{1 + c_p t}$$
.....(5)

a useful relation.

72. Regnault's determination of the coefficient of increase of pressure of a gas with temperature when the volume is constant. The relation between pressure and temperature for gases at constant volume was also investi-

gated by Regnault, using the apparatus already described in Art. 68 (Fig. 61). The mercury column was always brought back to m in order to keep the volume constant. This was done by pouring mercury in at E.

As a result of his experiments Regnault found

$$c_p = \cdot 003665,$$

which is slightly less than c_r . Similar results were obtained for other gases. The two coefficients are so nearly equal that for all practical purposes they are taken as identical and equal to $\frac{1}{273}$ (which equals $\cdot 003663$). In the following articles c or $\frac{1}{273}$ will be used indiscriminately for c_r and c_p .

GAS COEFFICIENTS BETWEEN 0° C. AND 100° C. (REGNAULT).

	At constant volume (initial pressure atmospheric).	At constant pressure (atmospheric).
Air	0·0036650	0·0036706
Hydrogen	0·0036678	0·0036613
Oxygen	0·0036743	—
Nitrogen	0·0036682	0·0036709
Carbon dioxide	0·0036856	0·0037099
Sulphur dioxide	0·0038450	0·0039028

73. The gas thermometer. One of the most important applications of the expansion of gases is the use of gases as thermometric substances. As gases expand much more than either solids or liquids a gas thermometer is much more sensitive than a mercurial one, the expansion of any gas for 1° C. being more than twenty times that of the same volume of mercury. Further, the expansion of a gas is so great compared with that of the vessel which contains it, that it is necessary to know only the approximate law of expansion of the latter.

If we take a mercury thermometer as our standard of temperature there is no option but to say that mercury expands uniformly with rise of temperature, and, strictly speaking, there is no meaning in the phrase. Also using a mercury thermometer to give our scale of temperature it has been found that gases do not expand absolutely uniformly. If, however, a gas thermometer graduated from its own indications is used, of course it may be said the

gas expands uniformly with the rise of temperature and also that mercury does not expand uniformly.

There is a third scale of temperature, the thermo-dynamic scale,* which is of immense theoretical importance in the study of the higher part of this subject, and therefore preferable to either the above. The theory of it is, however, too difficult to deal with here, and we must content ourselves by saying that since the gas-scale of temperature agrees more closely with the thermo-dynamic scale than the mercury-scale does, the gas-scale is taken as the absolute scale of temperature, and all temperature indicators made for practical use are graduated by comparison with a gas thermometer.

It does not greatly matter what gas is used in the thermometer as long as it is a fairly permanent gas, *i.e.* one whose point of condensation is a long way below the ordinary ranges of temperature, and thus we find air, oxygen, hydrogen, nitrogen, and helium being employed by different observers, but perhaps helium, from its chemical inactivity, is the best one to employ. There are other important reasons for the adoption of air, or other gas which does not easily condense, as a thermometric substance; these we shall consider later (Art. 99), when the question of specific heat has been dealt with.

Theoretically, the air thermometer may take one of two forms; any apparatus, by means of which the mean coefficient of expansion of air at constant pressure, or the mean coefficient of increase of pressure at constant volume has been studied, may be used as an air thermometer; for if c be known we can use the relation $V_t = V_0 (1 + ct)$ to determine t , thus--

$$t = \frac{V_t - V_0}{V_0 c},$$

or we can use the relation $P_t = P_0 (1 + ct)$ to determine t , thus--

$$t = \frac{P_t - P_0}{P_0 c}.$$

* See Stewart: *Higher Text-book of Heat*, Ch. XIV., for the thermo-dynamic scale.

We may therefore use as an air thermometer either of the forms of apparatus shown in Figs. 61 and 65. In practice, however, only one form is used.* Although the great expansion of gas is in one way an advantage, it is a great inconvenience if we wish to measure temperature by expansion at constant pressure, for the expansion is so great that a comparatively large proportion of the gas necessarily occupies, on expansion, portions of the apparatus which are not at the temperature it is desired to measure.† For this reason it has been found most convenient to employ the apparatus used to determine the mean coefficient of increase of pressure at constant volume (Fig. 65). In this apparatus the air can be kept throughout the experiment at the temperature it is required to measure, and this temperature is given by

$$t = \frac{P_t - P_0}{P_0 \alpha} = 273 \frac{P_t - P_0}{P_0}.$$

Here P_t is known from the barometric height (H) at the time of the experiment, and the difference of level (p) of the mercury columns in the two tubes. It is equal to $(H + p)$. P_0 is determined once for all by surrounding the bulb with melting ice and determining H and p in the same way as for P_t above. The scale on the instrument may be directly graduated in degrees once P_0 is determined. For, since the pressure increases by $P_0/273$ for every 1°C . rise in temperature, it is easily seen that the scale of

* In 1887 an International Committee of Weights and Measures adopted the following resolution: "That the International Committee of Weights and Measures adopt as the Normal Thermometric scale . . . the Centigrade scale of the (Constant Volume) Hydrogen Thermometer, having as fixed points the temperature of melting ice (0°) and that of the vapour of distilled water in ebullition (100°) under the normal atmospheric pressure, the hydrogen being taken under the manometric initial pressure of one metre of mercury." For high temperatures (200° - 600°) nitrogen or air is now preferred to hydrogen.

† Callendar has designed a constant pressure thermometer in which this error is eliminated by a compensation device. One great advantage of the constant pressure method is that the bulb is not subjected to any internal or external pressure strains,

Fig. 65 may be marked off in steps, each of length $P_0/273$, and then labelled the appropriate degrees.

If pressures are measured by mercury and $P_0 = 760$ mm., the degrees are $\frac{760}{273}$, *i.e.* 2.78 mm. in length.

Owing to the fact that the properties of air remain unchanged through a very wide range of temperature, the air thermometer may be used to determine very high or very low temperatures. When used at very high temperatures the bulb is made of porcelain, and in this form it is a most reliable pyrometer or instrument for measuring high temperatures. The details of construction of air thermometers vary greatly according to the purpose for which they are required; the bulb is often very long and cylindrical, as shown in Fig. 45. For other purposes it is comparatively small and spherical; but in all cases the method of experiment and the details of calculation are identical.

74. Absolute temperature. Imagine an air thermometer constructed out of a long tube of uniform bore in such a way that temperature is indicated by increase of volume at constant pressure, and let the air in the tube when at 0°C . occupy 273 cm. of the length of the tube. If this thermometer were plunged into steam produced at the normal atmospheric pressure the air would expand, showing an increase of volume equal to $\frac{100}{273}$ of its volume at 0°C . Hence, at 100°C . the air would occupy 373 cm. of the length of the tube, and if this space of 100 cm., between the freezing point and boiling point, is divided into 100 equal parts of 1 cm. each, then each division will correspond to 1°C . If now this method of division is carried down the tube below the freezing point, the reading at the bottom will be -273°C . This temperature is called the **absolute zero**.

If temperatures are reckoned from this point *as zero*, then the freezing point, which is 273°C . higher, is denoted by 273° Absolute (written as 273°A .), and the boiling point is at 373°A ., or, generally, $t^\circ\text{C}$. becomes $(273 + t)$ on the absolute scale, *i.e.* the temperature $t^\circ\text{C}$. = $(273 + t)^\circ\text{A}$., which is usually written $T^\circ\text{A}$. Since this absolute zero is at the *bottom* of the tube it would seem to imply that, at

this temperature, the volume of the air is reduced to nothing. This result is, of course, physically impossible, and only presents itself if we falsely assume that air remains a gas during the whole range of temperature between 0° C. and -273° C.; this we know is not the case, for at a certain temperature it would liquefy,* and at a lower temperature become solid; consequently its law of contraction would altogether change at these low temperatures.

Although the supposition on which the above calculation of the absolute zero is based is very crude yet this value of the absolute zero differs only by a few tenths of a degree from the accurate value obtained by refined calculations by Lord Kelvin and Professor Callendar.

In dealing with questions relating to gases it is exceedingly convenient to measure temperatures from this absolute zero, for if we do so we may state that the volume of a given mass of gas at constant pressure is proportional to its absolute temperature. Thus, in the case of the uniform air thermometer tube mentioned above, if the volume of 1 cm. of its length is denoted by v , then the volume of the air at 273° A. is $273 v$, at 373° A. it is $373 v$, and at T° Absolute it is given by $T v$, that is—

$$\frac{V_t}{V_{t_1}} = \frac{273 + t}{273 + t_1} = \frac{T}{T_1} \dots\dots\dots (6)$$

where T° and T_1° denote absolute temperatures corresponding to t and t_1 degrees C.

This can be derived from formula (3) (Art. 56), viz.

$$\frac{V_t}{V_{t_1}} = \frac{1 + ct}{1 + ct_1}$$

Here, $c = \frac{1}{273}$, therefore—

$$\frac{V_t}{V_{t_1}} = \frac{1 + \frac{1}{273}t}{1 + \frac{1}{273}t_1} = \frac{273 + t}{273 + t_1} = \frac{273 + t}{273 + t_1} = \frac{T}{T_1}$$

* Air liquefies at -192° C., i.e. 81° A. It is therefore perhaps better to define Absolute Temperature as temperature on such a scale that the volume of a given mass of a not easily liquefied gas is at ordinary or higher than ordinary temperatures proportional to the temperature. On this definition we need not worry about the absolute zero.

This enables us to state Charles's or Dalton's Law in the simple form—

The volume of a given mass of any gas at constant pressure varies directly as the absolute temperature,

$$\text{i.e. } \frac{V}{T} = \text{a constant when P is constant.}$$

Example. A given mass of oxygen occupies 24.0 c.c. at 15° C. Find its volume at 25° C. if the pressure is unchanged.

First change the Centigrade temperatures to absolute temperatures. They are 273 + 15 and 273 + 25. Then apply Charles's or Dalton's Law, and we get

$$\frac{24}{273 + 15} = \frac{V_{25}}{273 + 25};$$

$$\therefore V_{25} = 24 \times \frac{298}{288} = 24.8 \text{ c.c.}$$

In the same way if we consider the law of variation of pressure with temperature we shall find that the pressure exerted by a given mass of gas kept at constant volume is proportional to its absolute temperature. Thus, if the pressure at 0° C. is that due to 273 mm. of mercury, then since the pressure at constant volume increases or diminishes by $\frac{1}{273}$ of its value at 0° C. for a rise or fall of 1° C. we have—

the pressure at 100° C.	=	273 + $\frac{100}{273}$ · 273	=	373 mm.
„ „ - 1° C.	=	273 - $\frac{1}{273}$ · 273	=	272 mm.
„ „ - 10° C.	=	273 - $\frac{10}{273}$ · 273	=	263 mm.
„ „ - 273° C.	=	273 - $\frac{273}{273}$ · 273	=	0 mm.

If now we rewrite this table and express the temperatures as absolute temperatures we have—

pressure at 373° A.	is that due to	373 mm.	of mercury.
„ „ 272° A.	„ „	272 „	„
„ „ 263° A.	„ „	263 „	„
„ „ 0° A.	„ „	0 ..	„

This shows that the pressure is directly proportional to the absolute temperature. This result may be deduced directly from formula (5) (Art. 71) for,

$$\frac{P_2}{P_1} = \frac{1 + ct}{1 + ct_1} = \frac{1 + \frac{1}{273} t}{1 + \frac{1}{273} t_1} = \frac{273 + t}{273 + t_1} = \frac{T}{T_1} \dots \dots \dots (7)$$

The Law of Pressures now becomes :

The pressure of a given mass of any gas at constant volume varies directly as the absolute temperature,

$$i.e. \frac{P}{T} = \text{a constant when } V \text{ is constant.}$$

The two relations (6) and (7) which we have thus established are of great importance. It must be remembered that (6) is true only if pressure is constant, and (7) is true only if volume remains constant.

Example. A given mass of gas at -73°C . exerts a pressure of 60 cm. of mercury. What pressure will it exert at 27°C . if the volume is unchanged?

Apply the Law of Pressures and we get

$$\frac{60}{273 - 73} = \frac{P}{273 + 27};$$

$$\therefore P = 60 \times \frac{300}{200} = 90 \text{ cm. of mercury.}$$

The complete explanation of the absolute scale of temperatures belongs to Thermo-dynamics, and cannot here be considered; but it is interesting to know that absolute temperature, as determined by the air thermometer, corresponds very closely with absolute temperature properly so called, as determined from thermo-dynamic considerations.*

75. Graphical representation of the change of volume of a gas with temperature. The graph showing how the volume of a given mass of gas varies with the temperature when the pressure is kept constant is practically a straight line over ordinary ranges of temperature, as is shown by the straight line $V_0 V_{100}$ in Fig. 67. This has been proved in Exp. 32 (see Fig. 63). If this line is produced on the side of lower temperature it will be found to cut the temperature axis at the temperature -273°C . This is the graphic representation of the fact deduced in Art. 74, that the absolute zero of the air thermometer is -273°C .

* See Stewart: *Higher Text-book of Heat*, Ch. XIV., for the thermodynamic scale.

As explained in that article it is a physical impossibility that this graph should truly represent the change of volume, as the temperature is lowered to -273°C . and the graph for these low temperatures only represents what would happen if Charles's Law were applicable at all temperatures.

What actually takes place is indicated, *in a general way*, by the dotted line of Fig. 67 drawn for air. At normal pressure air liquefies at -192°C ., and as the temperature

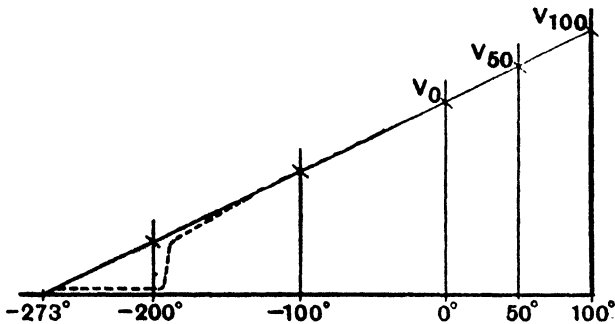

Fig. 67.

approaches -192°C . the volume of the air diminishes more rapidly than Charles's Law requires; this is shown by the dotted line falling below the continuous line. At -192°C . the volume suddenly decreases from that occupied by the gas at -192° to the volume of the corresponding liquid at -192°C . Below -192°C . the volume of the liquid decreases very slowly with decrease of temperature, but never becomes *nil*—that is, the dotted line gradually approaches the temperature axis, but does not reach it.

A curve which represents the relation between the volume and temperature at constant pressure is called an *isopiestic*.^{*} Fig. 67 shows an isopiestic for air. A curve which represents the relation between pressure and temperature at constant volume is called an *isometric*.[†]

^{*} Gk. *isos*, equal; *piezein*, to press.

[†] Gk. *isos*, equal; *metron*, a measure.

76. The general relation between pressure, volume, and temperature for a gas. If P , V , and T denote the pressure, volume, and absolute temperature of a given mass of gas it is possible to establish for these three quantities a simple general relation which includes the three relations discussed in this chapter.

From Boyle's and Charles's Laws we know that

V varies as $\frac{1}{P}$ when T is constant (Boyle's Law),

and V varies as T when P is constant (Charles's Law).

Hence, when both T and P vary, we have that

$$V \text{ varies as } \frac{T}{P}.$$

That is,
$$V = R \frac{T}{P}$$

where R is a constant.

This is conveniently written in the form

$$\frac{PV}{T} = R \text{ (a constant) } \dots\dots\dots (8)$$

That is, however P , V , or T may vary the quantity PV/T for a given mass of a given gas remains constant.

This is a very important equation, and should be remembered. It is called **The Gas Equation**.

From the above simple formula it is easy to calculate what volume a given mass of gas will occupy at any temperature and pressure if the volume at any other temperature and pressure is given.

Example. A quantity of gas measured at 27°C . and a pressure of 740 mm. has a volume of 400 c.c. Find the volume of the gas at 0°C . and 760 mm. pressure.

For 1st state of gas

$$T_1 = 273 + 27 = 300, \quad P_1 = 740, \quad V_1 = 400.$$

For 2nd state of gas

$$T_2 = 273, \quad P_2 = 760, \quad \text{and } V_2 \text{ is required.}$$

Therefore applying
$$\frac{PV}{T} = \text{a constant}$$

we get
$$\frac{740 \times 400}{300} = \frac{760 V_2}{273}$$

Hence
$$V_2 = 354 \text{ c.c.}$$

77. The general relation between pressure, density, and temperature. Since

$$\text{Mass} = \text{Volume} \times \text{Density}$$

the density of any given mass of gas is inversely proportional to the volume of the gas.

Denoting density by D we may then write Boyle's Law as

$$D \propto P \text{ when } T \text{ is constant,}$$

and Dalton's or Charles's Law as

$$D \propto \frac{1}{T} \text{ when } P \text{ is constant.}$$

Hence, when P and T both vary we have

$$D \propto \frac{P}{T},$$

which may be written in the form

$$\frac{P}{DT} = \text{a constant.}$$

Example. The density of hydrogen at 0°C. and 760 mm. is $\cdot 00009001 \text{ gm. per c.c.}$ Find the density at 100°C. and 780 mm.

Applying

$$\frac{P_1}{D_1 T_1} = \frac{P_2}{D_2 T_2}$$

we have

$$\frac{760}{\cdot 00009001 \times 273} = \frac{780}{D_2 \times 373}$$

$$\therefore D_2 = \cdot 00009001 \times \frac{780}{760} \times \frac{273}{373}$$

$$= \cdot 0000676 \text{ gm. per c.c.}$$

When one part of a volume of gas is heated more than the rest it becomes less dense, and since volume for volume its weight is now less than that of the colder gas which it displaces it rises and colder gas flows in to take its rest. Currents called **convection currents** are thus set up in the gas and colder portions of gas are rapidly brought near the source of heat. By this means, therefore, heat may be rapidly distributed through the gas. Convection currents may also be produced in the liquids in the same way. The fuller treatment of convection is reserved for Chapter VII.

78. A perfect gas. A perfect gas is a gas for which the relation

$$\frac{PV}{T} = R$$

is absolutely true whatever the values of P , V , T , T , of course, being measured on the thermodynamic scale. None of the existing gases is perfect, but gases like oxygen, nitrogen, hydrogen, and helium, which are liquefiable only with great difficulty, behave very nearly like a perfect gas for ordinary ranges of pressure and temperature, while gases like carbonic dioxide, sulphur dioxide, chlorine, which are easily liquefiable, show great departure from the relation $\frac{PV}{T} = R$ when the pressure is increased or the temperature diminished.

It follows that for a perfect gas Boyle's Law, *i.e.* $PV =$ a constant when T is constant, is absolutely true; also that V is absolutely proportional to T when P is constant, and that P is absolutely proportional to T when V is constant.

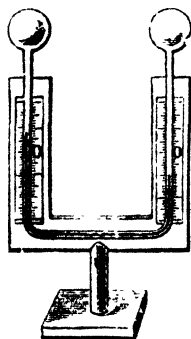

Fig. 68.

The student should prove that for a perfect gas the coefficient of increase of volume at constant pressure is exactly constant for all temperatures and equal to the coefficient of increase of pressure at constant volume.

79. The differential air thermoscope. Leslie's differential thermoscope (Fig. 68) consists of a bent tube terminating in two equal bulbs containing air; the bend of the tube contains coloured sulphuric acid,* and the quantity of air

in the bulbs is so adjusted that, when both are at the same temperature, the columns of acid, on each side of

* Any indicating liquid may be used, but water or spirit are not well adapted because of their volatility, mercury is unsuitable by reason of its great density, and glycerine and oil by reason of their viscosity. Coloured sulphuric acid is therefore commonly used.

the horizontal part of the bend, are at the same height. Thus constructed the instrument is very sensitive to *difference* of temperature of the air in the bulbs; the expansion of the air in the warmer bulb depresses the column of acid nearest it and correspondingly raises the other column.

Rumford's thermoscope is very similar to Leslie's; the horizontal part of the bend is much longer and contains a short thread of alcohol which, acting as an index, takes the place of the sulphuric acid columns.

These instruments are graduated by experiment. The bulbs are placed in water, and the position of the index corresponding to the same temperature in each is marked on the scale. A difference of 10 degrees is then established between the two bulbs and the corresponding index position again marked. The difference of temperature between the two bulbs is now reversed and another mark made on the scale. The space between these two extreme marks is then subdivided as required, and the position of the first mark is taken as the zero of the scale.

As a rule thermoscopes are used only to indicate and not to measure changes of temperature. They have been largely used in the study of Radiation (see Ch. XIV.).

EXERCISES VI.

- ✓ 1. State the effect on the volume of a given mass of air of altering its temperature without altering its pressure; also the effect on its pressure of altering its temperature without altering its volume.
- ✓ 2. A litre of hydrogen, at 10°C ., is heated at constant pressure to 293°C . Find its volume.
- ✓ 3. Air is enclosed in a vessel at 0°C ., and, the volume being kept constant, the temperature is lowered to -88°C ., at which temperature the pressure is found to be 385 mm. Find the pressure at 0°C .
- ✓ 4. Find the volume occupied at 0°C . and 760 mm. pressure by 500 c.c. of oxygen measured at 10°C . and 750 mm.
- ✓ 5. 1000 c.c. of air at 50°C . are cooled down to 10°C ., and at the same time the external pressure upon the air is increased from 750 mm. to 765 mm. What is the volume reduced to, the coefficient of expansion of air for 1°C . being 0.00366?

*6. In a determination of the coefficient of expansion of air by Gay Lussac's method the volume of the air in the tube was found to be 240 c.c. at 0°C . and at 77°C . its apparent volume was 310 c.c. Find the value obtained for the required coefficient. The mean coefficient of volume expansion of glass is 0.000026.

† 7. A porcelain air thermometer is used to determine the temperature of a furnace. The excess of the pressure of the air in the bulb over the atmospheric pressure is found to be that due to 1843 mm. of mercury. Find the temperature of the furnace, given that the barometric height at the time of determination equals 758 mm., and that at 0°C . the pressure of the air in the bulb was equal to that of the atmosphere.

8. A volume V of gas at pressure P and temperature T is heated (1) at constant pressure and (2) at constant volume to a temperature T' . Express in terms of P , V , T , and T' the resulting state in each case. [The state of a given mass of gas is expressed by giving its pressure, volume, and temperature.]

— 9. 10,000 c.c. of hydrogen at 20.0°C . and 760.0 mm. pressure occupy a volume of 9532.4 c.c. at 10.0°C . and 770.0 mm. pressure. Find the mean coefficient of expansion of hydrogen.

10. A litre of hydrogen weighs 0.090 gm. at 0°C . and 760 mm. pressure. Find the weight of a litre at 20°C . and 766 mm. pressure.

† 11. Compare the density of air at 10°C . and 750 mm. pressure with its density at 15°C . and 760 mm. pressure.

✗ 12. A flask containing air is corked up at 20°C . and heated in an air bath. A pressure of two atmospheres inside the flask will force the cork out: at what temperature will this take place?

† 13. Find the temperature of the absolute zero on the Fahrenheit scale.

14. 500 c.c. of oxygen gas are measured when the temperature is 20°C ., and the temperature is then raised to 40°C ., the pressure meanwhile remaining invariable. What is the volume of the oxygen at the latter temperature? (The coefficient of expansion of oxygen is $\frac{1}{273}$.)

15. 1000 cub. in. of air at a temperature of 30°C . are cooled down to 0°C ., and at the same time the external pressure upon the air is doubled. What is the volume reduced to, the coefficient of expansion of air being 0.00366?

CHAPTER VII.

CONVECTION.

80. Convection currents. Convection currents are set up in a fluid when the uniformity of density throughout its mass is disturbed by unequal heating. When a mass of liquid, for example, is heated from below the portions first heated expand, and thus becoming less dense than the surrounding liquid, are displaced upwards and give rise to an upward current from the point of heating. The liquid thus displaced upwards is replaced by the cooler liquid adjacent to it, and in this way downward and lateral currents feeding the upward current are established.

Similarly, if a gas flame or other heated body is placed in the middle of a room containing air at a uniform temperature, convection currents are at once set up. The air in the neighbourhood of the flame ascends and is replaced by air supplied by downward currents external to the ascending current.

Change of density of a gas is accompanied by change of refractive index. This explains why on a very hot day distant objects viewed through the air, lying over the hot surface of the land, appear to be quivering. The same appearance results when we look across the tops of burners or stoves at the objects in a room. The twinkling of stars is explained in the same way.

Exp. 36. In a beaker of water strew some paper pulp made by grinding a piece of blotting-paper in a mortar with a little water. Place it on a piece of wire gauze on a

tripod stand, and when the water has become nearly still put the flame of a Bunsen burner turned down low under the middle of the beaker (Fig. 69). Note the ascent of the warm water up the middle of the beaker and the in-draught of cold water from the top and sides.

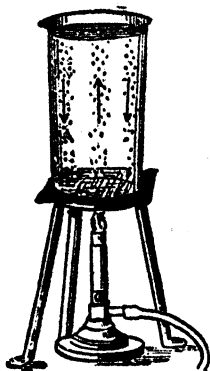

Fig. 69.

As a variation we may, instead of using paper pulp to indicate the flow, put a few magenta crystals at the middle of the bottom of the beaker. The stream lines along which convection occurs are then indicated in colour.

Exp. 37. In a similar beaker of water and paper pulp put a piece of ice. When the commotion due to the introduction of the ice has subsided, note the descending cold current from the melting ice and the in-draught currents of warmer water along the top towards the ice.

Exp. 38. Light a simple gas burner in a room where the air is not disturbed by draughts. Hold a piece of smoking paper near the burner and note the upward direction of the convection current. Also find in the same way, if possible, the direction of the currents which feed this upward current.

Exp. 39. Fill a *large* flask with smoke and note the convection currents set up by a small candle flame placed at the centre of the flask.

Exp. 40. Open a door between a warm room and the cooler passage or hall. Hold a lighted candle in the open doorway near the top and near the bottom and note, from the direction of the flame, the direction of the air current in each position. The current will be found to be outward from the room at the top and inward at the bottom. Close the door and find the direction at the key-hole.

81. Distribution of heat by convection. When a liquid in a vessel is heated from below the convection currents set up establish a system of circulation in the liquid. Under this system the liquid circulates round and round,

and every portion of it is, in turn, brought near the source of heat. In this way every part of the liquid is rapidly heated by the heat supplied at one point. It is for this reason that boilers are heated from below. (In cold weather convection occurs in ponds and lakes because the surfaces are cooled from above (cf. Hope's and Joule's experiments, Arts. 60, 61).)

Again, when a body cools in air or other gas the cooling is partly due to radiation, but mainly to convection. The circulation of the gas over exposed surface carries heat away from the cooling body.

Exp. 41. Set up the apparatus shown in Fig. 70, and fill the flask with litmus solution and the bottle with dilute acid. Heat the flask gently. Note the ascending current of litmus in B A, and the descending current of acid in C D E as it issues at E. Note also that the circulating liquid quickly assumes a uniform red tint, showing the rapid "mixing" effect of the convective circulation.

If acid coloured with litmus is placed in the flask, and alkali coloured with litmus in the bottle, and the quantities be adjusted to give exact neutralisation, the experiment is more effective.

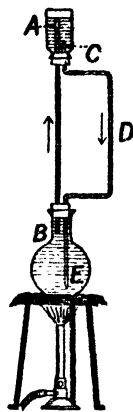

Fig. 70.

82. Heating by hot-water pipes. An application of convection currents is found in the system of heating buildings by hot-water pipes. The principle is the same as that of Exp. 41. The water in the boiler, which is placed at the lowest available position, is heated directly by the fire and rises through the outflow pipe, which should emerge from the boiler at its highest point, and, circulating round the network of pipes, return by the return pipe which enters the boiler at its lowest point. The rapidity of the circulation depends on the difference between the average densities of the water in the outflow pipe, from the boiler to the highest point reached, and that in the return pipes from the highest point to the boiler. This

difference of density itself depends on the difference of temperature, which should therefore be as great as possible, and for this reason the outflow pipe should pass vertically upwards as far as possible, so as to have a long vertical column of water at the highest possible temperature.

83. Ventilation. The simpler systems of ventilation are merely methods for establishing convection currents between the outside air and the air in the room to be ventilated in such a way as to promote free circulation of the air without creating draughts. The following experiment illustrates the principles applied in ventilation.

Exp. 42. Stand a candle in a saucer. Pour water around it. Light the candle and stand a tall cylindrical glass tube, such as a lamp chimney, over it. Note the candle goes out. This is due to lack of ventilation; no air can get in underneath the chimney—the water prevents that—and no air can flow down the chimney.

Repeat the experiment, this time introducing down the chimney a piece of cardboard or metal shaped like a T (Fig. 71). Notice that the candle continues to burn. There is a down-draught one side of the T-piece and an up-draught on the other side. To show this, hold some smouldering brown paper near one side of the cardboard and note the direction in which the smoke moves.

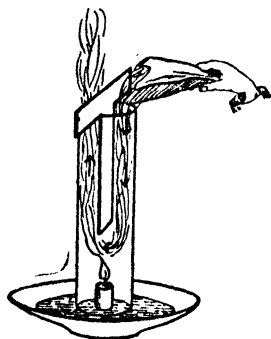

Fig. 71.

The experiment works much better if the candle is shifted so as to be underneath the column in which the up-draught occurs.

The draught in a chimney is also a means of ventilation. The heated air ascends and is replaced by colder air from the room, and thus a fire in a room to which the outer air has access is an effective means of ventilation.

It is of great importance that the true cause of convection in liquids and gases should be understood, and confining ourselves to one particular case let us consider the case of the draught in a chimney when a fire is lighted at the bottom. Let Fig. 72 represent a chimney stack standing, say, outdoors. When a fire is lighted on the hearth the air immediately above the fire is heated and therefore expands. This expansion forces some of the air in the front of the fire outwards. At this stage let us stretch an imaginary diaphragm XY across the mouth of the fireplace. We will now consider the pressures on the two sides of XY .

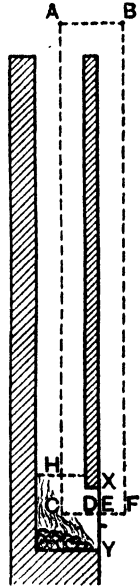

Fig. 72.

Take two points A, B , on the same level near the top of the chimney, A being over the hole of the chimney and B just outside the chimney, and two points D, E , on the same level on the two sides of XY . Draw verticals AC, BF from A, B , cutting the horizontal through D, E , in C and F . Let H be the point where AC enters the region of warm gas near the fire.

Then if $P =$ pressure of the air at A and B ,

$\rho =$ density of the air lying along AH and BF ,

$\rho_1 =$ density of the hot gas in the region HCD ,

the pressure at $D = P + AH \cdot \rho \cdot g + HC \cdot \rho_1 \cdot g \dots (1)$

and the pressure at $E = P + BF \cdot \rho \cdot g \dots \dots \dots (2)$

Therefore from (1) and (2)

pressure at $E -$ pressure at $D = HC(\rho - \rho_1)g \dots (3)$

The right-hand member of (3) is positive. There is thus a force acting from right to left across XY , and as a result of this force the diaphragm XY is forced towards the fire, or if we remove the diaphragm air from outside is forced into the neighbourhood of the fire. The region, HC , of heated gas thus gradually extends. The pressure difference at XY thus gradually increases and is a maximum

when the whole chimney is full of hot gas. The draught up the chimney thus gradually increases until the fire is at its height.

When a number of people are in a room the air in their neighbourhood is rendered less dense than the rest of the air on two accounts: (1) by the rise of temperature, (2) by the presence of water vapour from the breath (see Art. 176). This air rises, as explained above, to the upper part of the room. If there is no exit for this hot impure air it gradually accumulates and the room gets "stuffy."

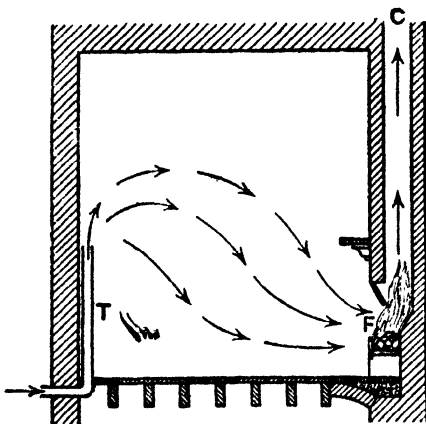

Fig. 73.

draught along the room and the upper part of the room will remain foul.

The Tobin tube, T (Fig. 73), has been designed to remedy this state of affairs. The tube communicates at its lower extremity to the outer air, and at its upper end to the room at about five feet from the ground. The draught up the chimney C causes air to rise up the Tobin tube, and this air thoroughly cleanses the upper part of the room before also taking its departure up the chimney. In some cases the Tobin tube is built around the chimney so that the incoming air is warmed (warmed without being fouled) before it enters the room.

Ventilators should therefore be provided at the top of the room for the exit of this gas, and ventilators near the floor of the room for the inlet of fresh air.

If there is an open fire in the room the chimney serves as an exit for most of the gas. If, however, the incoming fresh air is not thoroughly mixed with the air of the room there is likely to be a cutting

Rooms which are properly constructed for thorough ventilation in the summer often act badly in the winter, because the large up-draught in the chimney caused by the fire makes all other openings to the room serve as inlets of air. A warm central staircase acts in the same way.

In the old methods of ventilating mines two shafts used to be sunk, and these were connected at the bottom by the workings. A fire was lighted at the bottom of one shaft. This produced an up-draught and a current of fresh air then descended the other and permeated the workings.

There are also mechanical methods of ventilation in which fans and pumps are used to circulate the air. These methods do not come under the head of thermal convection.*

84. Winds. The familiar phenomena of winds are good examples of convection currents set up in the atmosphere by unequal heating. As examples we may consider:—

Land and sea breezes. Land absorbs solar heat more rapidly than water, and, owing to its smaller specific heat,† is raised to a higher temperature by the heat thus absorbed. For the same reason land loses heat more rapidly than water. Hence, during the day the land gets heated by solar radiation to a greater degree than the sea, and the air in contact with it also gets heated, expands, and, rising, is replaced by the cooler air over the sea, thus causing a sea breeze. After sunset, however, the land cools more rapidly than the sea, and ultimately the air over the land becomes colder than that over the sea; the direction of the current of air is then reversed, and during the night a land breeze prevails.

The trade winds. The surface of the earth within the tropics becomes greatly heated by the sun, and this heat is communicated to the air in contact with the earth, causing it to ascend. To replace this air, a current of colder air sets in from the polar and temperate regions, thus tending

* For fuller details of ventilation reference may be made to *Air Currents and the Law of Ventilation*, by Dr. W. N. Shaw, the Director of the Meteorological Office (Camb. Univ. Press), and to *Hygiene for Students*, by Dr. Willoughby (Macmillan).

† See Art. 90.

to produce a north wind in the northern hemisphere, and a south wind in the southern hemisphere.

To determine the actual direction of the wind it is, however, necessary to consider the rotation of the earth from west to east. A point on the surface of the earth near the equator has a velocity, from west to east, of more than a thousand miles per hour; but this velocity decreases as we approach the poles, where it becomes zero. Hence, if a mass of air starts from a place having a velocity, from west to east, of eight hundred miles per hour, and flows towards the equator, its direction relative to the surface of the earth will gradually tend towards the west, until, on reaching the equator, it will have a relative velocity of many miles per hour from east to west.

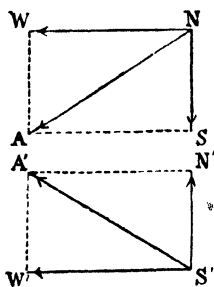

Fig. 74.

Hence, if, at a point on the borders of the temperate and tropical zones in the northern hemisphere, NS (Fig. 74) represents the velocity of the current of air towards the equator, and NW represents its relative velocity towards the west, then NA represents in magnitude and direction the actual velocity of the wind relative to the surface of the earth.* Similarly $S'A'$ represents the magnitude and direction of the wind in the southern hemisphere. Thus, a north-east wind † is produced in the northern hemisphere, and a south-east wind in the southern hemisphere. These winds are known as the trade winds.

The directions of the trade winds of course vary with the latitude and the shape of the surrounding coasts. Students should consult their atlases to see how far this simple theory agrees with fact.

85. Ocean currents.—If any part of the ocean is subject to constant, or nearly constant winds, the result must be to blow the surface waters in the direction in which the wind blows, and thus give rise to drift currents. Notably the

* This is an application of The Parallelogram of Velocities.

† A north-east wind is a wind from the north-east.

trade winds by their great constancy have such an effect on the waters of the equatorial belt. Both the N.E. and S.E. Trades conspire to drive the surface waters of the equator towards the W., and thus give rise to the *Atlantic and Pacific Equatorial Drift Currents*. If there were no obstructing land, these currents would flow continuously round the earth. But as it is, when they reach the western sides of their oceans they are deflected in directions determined by the configuration of the land.

Consider the Atlantic Equatorial Drift. It is a wide belt of hot water about 50 fathoms deep, blown across



Fig. 75.

from the African side at the rate of about 18 miles a day. On reaching the wedge-shaped coast of Brazil it is divided, one small branch proceeding southward, but the greater part travelling along the northern coast and between it and the West Indian Islands into the Gulf of Mexico. Here it has been greatly converged and accelerated as by a funnel, and sweeping round the Gulf it issues from the narrow Florida Strait with a speed of about four miles an hour, or about five times its original rate, and still retaining so much heat that its temperature ranges from 77° to 83° F.

It is now known as the *Gulf Stream* (Fig. 75), and flows in a north-easterly direction across the Atlantic. Even off

the Newfoundland Bank, when it has travelled more than 2,000 miles from its point of origin in Florida Strait, its temperature is 20° to 30° F. higher than that of the surrounding water, on which it accordingly floats. But its speed is now greatly reduced by its spreading out in a fan shape.

So far it may be considered to have travelled under the original impulse derived from the trade winds, but when this force has nearly ceased to be effective it reaches the region of prevalent S.W. winds, by which it is carried on in the same north-easterly direction until it reaches the western coasts of the United Kingdom, France, and Norway, where its influence in mitigating the severity of the winter in those countries is very great. The ports of Western Norway are never ice-bound, whereas those much further south on the Baltic coast of Sweden, to which the warm waters of the Gulf Stream do not penetrate, are regularly frozen up for months every winter. It is the very high specific heat of water that enables the Gulf Stream to give out so much heat to the countries washed by it.

A large number of ocean currents are surface drifts, due to the action of prevailing winds, like the Gulf Stream when it reaches N.W. Europe, but some are due to convection. Thus the cold in the Arctic regions causes water to sink and flow towards the equator as a deep current, while the surface water at the equator flows towards the poles, to replace the water carried away by this under-current.

Much work has been done on the Gulf Stream in recent years to elucidate its real cause and the effects it may have on the climate of N.W. Europe and the fisheries of the adjacent seas.

EXERCISES VII.

1. Wherein does the manner in which heat is usually diffused through liquids and gases differ from its mode of diffusion through solids?
2. Explain the heating of a building by hot water circulating from a single boiler in the basement.
3. What is the use of ventilation, and what are the means by which it is usually carried out?

4. (a) Why do the lower parts of the ocean never get warm?
- (b) Why is the surface-water of the ocean sometimes saltier than that below?
- (c) Why is ocean-water near land sometimes less salt than that far away?
- (d) Why are the warm currents, like the Gulf Stream, confined to the surface of the ocean?

EXAMINATION QUESTIONS ON THERMOMETRY AND EXPANSION.

1. Describe the method of construction and graduation of a mercury thermometer.

What are the properties of mercury which make it a good substance to use for thermometry?

2. Being given a mercury thermometer the bore of which is uniform, describe how you would determine any possible errors in its standard points, and show how, knowing these errors, you could construct a graph from which the error of any other reading within the range of the thermometer might be directly read off.

3. Describe a clinical thermometer. How is it constructed so as to have a restricted range of scale? How would you test it if you had reason to suspect its accuracy of reading?

4. Two thermometers, one (A) with a Centigrade graduation, the other (B) with a Fahrenheit graduation, when immersed in the same liquid bath gave respectively the following readings:—

A : - 10·1, 0, 10·2, 19·8.

B : 14·5, 32·4, 50·6, 68·3.

Calculate a table to show the error of the Fahrenheit thermometer at each temperature, assuming the Centigrade thermometer to be correct.

Plot a curve between error and temperature and deduce the probable corrections to be applied to B at 20° F., 30° F., 40° F., 60° F.

NOTE.—The thermometers are only read to the first decimal place.

5. A given mercury thermometer is graduated in degrees Centigrade from the freezing point to the boiling point of water. The bulb of the thermometer has a capacity of 0·8 c.c. and the internal area of cross section of the stem is 0·05 sq. mm. Neglecting the coefficient of volume expansion of glass in comparison with that of mercury, which is approximately 0·00018, estimate the distance between consecutive divisions of the thermometer scale.

6. Describe carefully a method of determining the coefficient of linear expansion of a solid between 0° C. and 100° C.

A rod is found to be 100 cm. long at 50°C . and 100.1 cm. long at 100°C . Assuming that it expands uniformly, obtain a formula giving its exact length at any temperature, and calculate its coefficient of cubical expansion.

7. The coefficients of linear expansion of copper and iron being .000018 and .000012 respectively, find at what temperatures two bars of copper and iron, which are each 100 cm. long at 15°C ., would differ by .1 cm.

8. Two equal bars of iron and copper respectively are laid side by side, and are firmly attached to each other at their ends by short cross pieces. When a piece 1 foot long is cut out of the middle of one of the bars, it is found that, however the temperature alters, the distance between the cut ends of the two pieces left remains always the same. Which bar is cut, and what is its length?

9. What is meant by the linear, the superficial and the volume coefficient of expansion with rise in temperature, and how are they related? If it takes a force of 20,000 kilogram.-wt. per sq. cm. to produce a one per cent. diminution of length in an iron bar, what force would you expect it to require to prevent a bar 8 cm. long, 3 cm. wide, and 2 cm. deep from expanding lengthways when raised 500°C . ?

10. The graduations of a mercury thermometer between 0°C . and 100°C . are equidistant, and the boiling point was marked when the bulb and the whole of the stem were at 100°C . Assuming the coefficient of expansion of glass to be negligible and that of mercury to be .00018, find what the reading of the thermometer would be if the parts below and above the 0° mark were at 100°C . and at 20°C . respectively.

11. Describe and explain a method of comparing experimentally the expansions of other liquids with that of mercury.

12. Describe how to use the weight thermometer for the measurement of temperature.

13. A glass bulb with a uniform fine stem weighs 10 gm. when empty, 117.3 gm. when the bulb only is full of mercury, and 119.7 gm. when a length of 10.4 cm. of the stem is also filled with mercury: calculate the relative coefficient of expansion for temperature of a liquid which, when placed in the same bulb, expands through the length from 10.4 to 12.9 cm. of the stem when warmed from 0°C . to 28°C .

14. Describe how the coefficient of absolute expansion of mercury with rise of temperature may be found.

15. Show how to determine the coefficient of expansion of a liquid by comparing the heights of two columns of the liquid at different temperatures. Explain the theory of the method.

16. Find the value in gm.-wt., and in dynes, per sq. cm., of a pressure able to sustain a 50 centimetre column of mercury at 0°C . Find what pressure would be exerted by the same height of mercury at 100°C . if its density at 0°C . is 13.6 gm. per c.c., and its mean coefficient of expansion is .00018.

17. Describe an experiment which proves that the density of water is greatest at about 4°C .

The bulb of a thermometer is filled with water instead of mercury. Describe the behaviour of the instrument as the temperature is raised from just above the freezing point to just below the boiling point.

18. Describe some method by which the expansion of water has been studied.

If δ be the expansion of water between 4°C . and 0°C ., and Δ its expansion between 4°C . and $t^{\circ}\text{C}$., show what is the density of water at $t^{\circ}\text{C}$. referred to water at 0° .

19. A vertical tube is placed with its lower end under mercury. The upper end is closed. When the barometer stands at 30 inches the mercury is at the same level inside and out, and the tube which contains air rises 60 inches above the mercury.

What is the height of the barometer (to the nearest tenth of an inch) if, when at the same temperature, the mercury has risen one inch inside the tube, the level outside being maintained the same as before?

20. Describe how to measure the relation between the pressure and volume of a mass of gas at constant temperature. If 310 c.c. of a gas at a pressure of 230 mm. of mercury are subjected to a pressure of 460 mm., what will be the resulting volume?

21. The mercury in a barometer containing some air stood at a height of 70 cm. and the volume of the tube above the mercury was 20 c.c. The tube was then lowered into the mercury reservoir until the volume above the mercury was 10 c.c., when the barometer indicated 65 cm. only. Calculate (1) the true barometric height and (2) what the reading of the barometer in question would be if its tube were raised until the volume above the mercury became 100 c.c.

22. State in words, and also in symbols, the two laws which, if a gas obeys, it is called a perfect gas, and explain clearly how the symbols represent the same laws as the words.

23. State the laws connecting volume and pressure, and those connecting density and temperature, of a gas; and explain how to calculate the effect on the density of a given mass of a gas of changing both its pressure and its temperature.

24. A sample of gas was found to have a volume of 100 c.c. at 18° C. and 72 cm. of mercury pressure and a volume of 200 c.c. at 90° C. and 45 cm. pressure. Assuming that the gas obeys Boyle's Law and expands uniformly at constant pressure, calculate at what temperature it would have a volume of 400 c.c. at 100 cm. pressure.

25. Find the number of cubic feet in a steel bottle to hold, at 120 atmospheres pressure when the temperature is 25° C., 20 cubic feet of oxygen measured at 0° C. and 1 atmosphere pressure.

26. Define the coefficient of increase of pressure of a gas. How would you find it experimentally? Show that, if a gas obeys Boyle's and Charles's laws, this coefficient is equal to the coefficient of expansion.

27. Describe experiments which show that in a perfect gas $\frac{PV}{T}$ has a constant value, where P , V , and T represent respectively the pressure, volume, and absolute temperature of a given mass of the gas.

28. At the sea-level the barometer stands at 750 mm. and the temperature is 7° C., while on the top of a mountain the barometer stands at 400 mm. and the temperature is - 13° C. ; compare the weights of a cubic metre of air in the two places. (The barometer readings are supposed corrected for temperature.)

29. Explain how the apparent weight of a body in air varies with its rise of temperature.

A piece of iron measuring 1000 c.c. is weighed at 0° C. and again at 100° C. What will be its apparent change in weight?

Coefficient of expansion of air = 0.00367

 " " " iron (linear) = 0.000012

Mass of 1000 c.c. of air at 0° C. and 760 mm. = 1.293 gm.

The pressure is supposed to be normal throughout.

30. What is meant by a scale of temperature and on what does the definition of any particular scale depend? Explain carefully the construction and mode of action of some form of constant pressure air thermometer.

31. What is an air thermometer? How is it constructed, and how is it used? What means have we, besides the air thermometer, of measuring temperatures between 400° and 800° C.?

32. What is meant by convection? Explain the effect of convection in producing regular atmospheric currents such as Trade winds.

33. Explain the formation of land and sea breezes and of the Trade winds.

CHAPTER VIII.

CALORIMETRY.* SPECIFIC HEAT.

86. **Quantity of heat.** We are already quite familiar in a general way with the idea of *quantity of heat*. A greater quantity of heat is required to heat a large mass of water from 0° C. to 100° C. than to heat a small mass through the same range of temperature; a considerable quantity of heat is required to convert a pound of ice at 0° C. into water at 0° C.; and a pound of steam in condensing gives out a large quantity of heat. Also a pound of coal in burning gives out a quantity of heat which varies with the quality of the coal; the quantity of heat given out by a gas flame depends upon the quantity of gas used per second, and the completeness of its combustion; and the quantity of heat evolved in a chemical reaction varies with the nature of the reaction and the conditions under which it takes place.

The meaning of the term "quantity of heat" used in this general way is well understood, but it is necessary for a further study of the subject to decide exactly how quantity of heat is to be measured or in what units it is to be expressed.

In this study of quantity of heat no assumption will be made as to the nature of heat. At one time heat was thought to be a weightless fluid. This fluid, to which was given the name *caloric*, was able to flow from one body to a colder body. At present heat is considered to be energy, the energy of vibration and of position of the molecules of a body. For elementary students the fluid theory offers perhaps the best basis for the study of quantity of heat.

* L. *calor*, heat; *metrum*, a measure.

87. Unit of heat. If quantity of heat is to be *measured* it is evidently essential to decide on a *unit* of measurement. An obviously convenient unit is the quantity of heat required to raise unit mass of some standard substance through one degree. The unit generally adopted is of this type.

Definition. The unit quantity of heat is the quantity of heat required to raise unit mass of water one degree at some standard temperature. If the mass is the gramme and the degree the degree Centigrade, this unit is called a *calorie*.

Unless, however, we specify the temperature we may not get a constant unit of heat, for it cannot be assumed that the same quantity of heat is required to raise one gramme of water 1°C . wherever that degree may be on the scale of temperature; in fact, experiment proves that different quantities of heat are required. It remains then to choose some particular temperature.

Another proposed unit of heat is the one-hundredth part of the heat required to raise one gramme of water from the freezing point (0°C .) to the boiling point (100°C .). This has been called the *mean calorie*.

The standard temperature mentioned above has been chosen to be such that the value of the calorie at that temperature is exactly equal to the mean calorie as defined above. This temperature is 17.5°C .* We are thus led to the following definition:—

Definition. The unit of heat is the *calorie*, the calorie being defined as the quantity of heat required to raise one gramme of water from 17°C . to 18°C ., or as one-fifth of the quantity of heat required to raise one gramme of water from 15°C . to 20°C ., or as one-hundredth of the quantity of heat required to raise one gramme of water from 0°C . to 100°C .

The first alternative definition is useful, as in practical calorimetry a range of temperature of only 1°C . is rather small to work with, and a wider range of temperature is required.

* If further accuracy is required this might be given as 17.5°C . on the constant volume hydrogen thermometer at 1 metre initial pressure.

Although in accurate work it is thus necessary to define the calorie in terms of some standard temperature, yet the difference between the heat required to raise the temperature of one gramme of water 1°C . measured at any part of the scale and the heat required to raise the temperature of one gramme of water from 17°C . to 18°C . is so small that in ordinary practice it is quite sufficient to assume that they are alike, and to take the calorie as the heat required to raise the temperature of one gramme of water 1°C . without any further reference to the part of the scale where this 1°C . is to be taken.

The calorie is often called the gramme-degree. Other similar units to the calorie are the pound-degree (Centigrade) and the pound-degree (Fahrenheit), which involve the pound as the unit of mass instead of the gramme. These units are used chiefly by English-speaking engineers.

It will be shown later that, as heat is a form of energy, it may be measured in energy units such as *ergs* or *foot-pounds*, and that a unit of heat may thus be defined without reference to any substance or scale of temperature.

Exp. 43. Take 500 gm. of water at 0°C . in a thin glass beaker, and 50 gm. of water at 11°C . in another beaker. Mix the two quantities of water in the first beaker and note the final temperature. It will be found to be approximately 1°C .

Now, in this experiment the 500 gm. of water at 0°C . is raised to 1°C ., and therefore gains 500 calories. If we assume that there has been no loss or gain of heat in the mixture, this 500 calories of heat must have been given out by the 50 gm. of water at 11°C . in cooling to 1°C . That is, 50 gm. of water in cooling through the 10 degrees between 11°C . and 1°C . gives out 500 calories. This indicates that each gm. of water in cooling through each degree between 11°C . and 1°C . gives out one calorie.

Further, if any two quantities of water at any temperatures between 1°C . and 100°C . be mixed, the final temperature, *given by experiment*, is always found to be nearly in accord with the assumption that one gramme of water in cooling through *any* one degree gives out one unit of heat. Hence it is usually assumed that one gramme of water in

heating or cooling through one degree of temperature gains or loses one unit of heat wherever the degree be taken between 0°C . and 100°C .

Example. 50 gm. of water at 10°C . are mixed with 100 gm. of water at 40°C . Find the temperature of the mixture.

Let $t^{\circ}\text{C}$. denote the final temperature of the mixture.

Then the warm water cools from 40°C . to $t^{\circ}\text{C}$., and loses $100(40 - t)$ calories.

Also the colder water is heated from 10°C . to $t^{\circ}\text{C}$., and gains $50(t - 10)$ calories.

Now, if there be no loss or gain of heat for the mixture, the heat lost by the warmer water must be exactly equal to that gained by the colder water, and we therefore, in this case, have

$$100(40 - t) = 50(t - 10) \text{ or } t = 30.$$

That is, the final temperature is 30°C .

It must be noted here that in experiments of this kind it is very difficult to avoid serious errors. The transfer of heat is not confined to the two quantities of water. The vessels containing the water take a part in the exchanges of heat, and there may be considerable loss or gain of heat due to radiation. It will be explained later how these errors may be to some extent avoided.

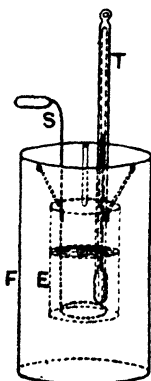

Fig. 76.

88. The Calorimeter. A unit of heat having been fixed, it remains to indicate how quantity of heat may be measured in terms of the selected unit. The apparatus used for the purpose of measuring quantity of heat is known as a *Calorimeter*. It consists essentially of a thin metal vessel (usually of copper, brass, or silver) partly filled with water and fitted with a stirrer and accurate thermometer. The vessel must be arranged so as to be protected as far as possible from loss or gain of external heat. Fig. 76 shows a convenient form of

the apparatus.

The calorimeter E, capable of containing, say, 300 grammes of water, is suspended by three loops of cotton

that catch on hooks inside a larger metal vessel F*, which protects it from loss or gain of heat by conduction. The outer surface of E and the inner surface of F are smooth and polished, or plated, to minimise the effect of radiation. The stirrer S is a ring of wire with a vertical branch carrying a small wooden or glass handle. The thermometer T, when in use, should have its bulb well immersed in the water.

To prepare the calorimeter for the measurement of quantity of heat a convenient quantity of water is placed in E, and its mass determined by direct weighing. It is then well stirred and its temperature read just before the hot body is placed into it.

Exp. 44. To measure with a calorimeter the quantity of heat given out by a hot piece of metal dropped into the water in the calorimeter. Prepare the calorimeter as explained above and note the temperature of the water. Drop the piece of hot metal (heated, for example, by immersion in boiling water, or in a steam or air oven) into the water in the calorimeter without splashing, and note the final temperature attained when the exchange of heat is complete and the temperature of the mixture is uniform.

Let, for example, the initial temperature be 10°C . and the final temperature 11.5°C . Then, if the mass of water in the calorimeter is 200 gm. the quantity of heat given out by the hot metal is that necessary to raise 200 gm. of water through 1.5 degrees of temperature. That is, the quantity of heat given out is $200 \times 1.5 = 300$ calories. This is evidently the heat given out by the metal in cooling from its initial temperature to 11.5°C .

If the mass of water is known and the change of temperature accompanying any loss or gain of heat be observed, the quantity of heat lost or gained is easily determined. If the mass of water in the calorimeter is M grammes and a change of temperature of $t^{\circ}\text{C}$. is observed, the quantity of heat gained or lost by the water in the calorimeter is Mt calories.

89. The "water equivalent" of the calorimeter. In the explanations given in the preceding articles the quantity

* Instead of using hooks, the space between the calorimeter and the outer vessel may be packed with *dry* cotton-wool or some other bad conductor of heat.

of heat absorbed by the calorimeter, stirrer, and thermometer has been neglected. In Exp. 44, for example, the apparatus absorbs some of the heat given out by the piece of metal, so that the total quantity of heat given out is the 300 calories absorbed by the water and a certain unknown number of calories absorbed by the apparatus. If the apparatus is of small mass this quantity of heat will be small, but it cannot usually be neglected.

The simplest way of correcting for this absorption of heat by the apparatus is to consider that the presence of the apparatus is *equivalent* to a small addition to the quantity of water in the calorimeter, and to determine the amount of this addition for any particular apparatus, by experiment. *The mass to be added to the mass of water in the calorimeter as the equivalent of the apparatus in the absorption or evolution of heat is known as the water equivalent of the calorimeter.*

Exp. 45. Determine the water equivalent for a calorimeter. Take the calorimeter and fill it about one-third full with water, and note the mass of water taken. Stir till the temperature is uniform. Note this temperature and at once add a mass of water at a different temperature sufficient to about two-thirds fill the calorimeter. Stir until the temperature of the "mixture" is uniform, and note the final temperature. Then determine the mass of water added by finding the increase in the mass of the calorimeter and contents. It is most convenient to take the water in the calorimeter at a temperature of 30°C . or 40°C . and to add to it water *at the temperature of the room*. From the data obtained in an experiment of this kind the water equivalent may be calculated.

Example. In an experiment like the above the mass of water first taken was 100 gm. and its temperature 35°C . The mass of the water added was 110 gm. and its temperature 15.5°C . The final temperature of the "mixture" was 25°C . Find the water equivalent of the calorimeter.

Let x denote the water equivalent of the calorimeter, then the heat lost by the warm water and the apparatus in cooling from 35°C . to 25°C . is $(100 + x) 10$ calories.

Also the heat gained by the cold water in being heated from 15.5°C. to 25°C. is 110×9.5 calories. Hence, if no heat is lost during the experiment we must have

$$(100 + x) 10 = 1045.$$

That is $10x = 45$ or $x = 4\frac{1}{2}$ gm. approximately.

90. Specific heat. If equal masses of different substances take in (or give out) different quantities of heat when heated (or cooled) through the same range of temperature the substances are said to have different specific heats.

Definition. The specific heat of any substance is the number of units of heat required to raise unit mass of that substance one degree of temperature.

Thus, if $\frac{1}{10}$ th of a calorie is required to raise one gramme of a substance 1°C. the specific heat of the substance is $\frac{1}{10}$.

The specific heat of water is unity, for we have defined the unit of heat as the quantity of heat required to raise unit mass of water one degree.

The following simple experiments show that the specific heats of different bodies vary considerably.

Exp. 46. Take five small spheres of iron, copper, tin, lead, and bismuth, all of the same mass, and heat them to the same temperature in a bath of water, or better, linseed oil. Then remove them quickly, dry them with blotting-paper, and place them on a thick* cake of wax (Fig. 77). They will at once begin to give out heat to the wax, which will melt under them until they cool down to the temperature at which the wax solidifies. Watch how far each one sinks (Fig. 77). Observe that the order is as follows:—iron, copper, tin, lead, and bismuth, the iron being in furthest. It is obvious that this is also the order of their specific heats.

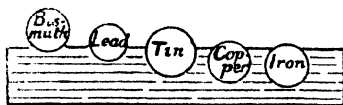

Fig. 77.

* If the cake is thin and some balls get through, no logical conclusion as to specific heat can be drawn from the fact that one ball gets through quicker than another. It is then a question of relative conductivity as well as specific heat.

Exp. 47. Heat 200 gm. of thin sheet lead (loosely rolled) and 200 gm. of water in the same beaker. Provide two other beakers containing equal quantities of water at the ordinary temperature, say 200 gm. at 15°C. in each. Put the hot lead into one of these beakers and the hot water into the other, and observe in each case the rise of temperature produced. The rise of temperature due to the hot water will be found to be much greater than that due to the hot lead.

For example, if the water and lead were originally at 100°C. the final temperature in the beaker to which the water is added would be found to be about 58°C., and in the beaker to which the lead is added it would be found to be only about 18°C., that is the changes of temperature are respectively 45°C. and 3°C. Therefore 200 gm. of water in cooling from 100°C. to 58°C., i.e. through 42°C., give out about *fifteen* times the quantity of heat given out by the same mass of lead in cooling from 100°C. to 18°C., i.e. through 82°C., or, roughly, twice 42°C. Hence a gm. of lead in cooling through one degree gives out about *one-thirtieth* of the heat given out by a gm. of water in cooling through one degree. That is the specific heat of lead for heat is about one-thirtieth that of water.

Exp. 48. (a) Heat 200 gm. of iron wire to 100°C. and "mix" it with 200 gm. of water at 10°C.

(b) Mix 200 gm. of water at 200°C. with 100 gm. of iron at 10°C.

From the results calculate the specific heat of iron.

Note that when *equal* masses of different substances at different temperatures are "mixed" the changes of temperature produced are inversely proportional to the specific heats of the substances. Thus in Exp. 48 (a) and (b) the changes of temperature of the iron are nine times that of the water, indicating that the specific heat of iron is one-ninth that of water.

Exp. 49. Mix 200 gm. of water at 100°C. with 200 gm. of turpentine at the ordinary temperature. Find the specific heat of turpentine from the relative changes of temperature which result.

The mean specific heat of any substance for any range of temperature is the average value, for that range, of the number of units of heat required to raise unit mass of the substance through one degree.

Thus, if Q units of heat are required to raise unit mass of a substance from $t^\circ\text{C.}$ to $t'^\circ\text{C.}$, then $Q/(t' - t)$ is the

mean specific heat of the substance between t° C. and t° C. Also if s denote the specific heat of any substance the quantity of heat required to raise m units of mass of the substance from t° C. to t° C. is $m s (t' - t)$ units.

The specific heat of a substance at any temperature is the mean specific heat of the substance for a very short range of temperature including the given temperature. For example, the specific heat of copper at 50° C. may be taken as the mean specific heat between 49° C. and 51° C. It is evident that the shorter the range taken the more exactly does the mean specific heat for the range give the specific heat at a definite temperature.

The product of the mass of a body and its specific heat is sometimes called the thermal capacity of the body.

Sometimes we require the *specific heat of unit volume* of a body. The mass of unit volume being the density of a body it follows that the specific heat of unit volume of a body is equal to the product of the specific heat of unit mass and the density.

91. Experimental determination of the specific heat of a solid. A very rough determination of the specific heat of a solid may be made by the method of the following experiment.

Exp. 50. Take a piece of brass tube about 100 grammes in mass and weigh it. Attach a piece of thread to it, and immerse it in boiling water so that it can be lifted out when required by means of the thread. Set up the calorimeter as described in Art. 88, and note the temperature of the water in it. Then remove the brass from the boiling water, shake off the adhering water, and transfer it as rapidly as possible into the water in the calorimeter. Now stir the mixture and note the maximum temperature reached.

Example. Suppose that the following were the numbers relating to such an experiment:

Mass of brass tube = 95.4 gm. Its initial temperature 100° C.

Mass of water in calorimeter = 200 gm. Water equivalent of calorimeter = 4 gm.*

Initial temperature of water and calorimeter = 14° C. Final temperature of water, calorimeter, and brass = 18° C.

Then if s = mean specific heat of brass between 18° C. and 100° C., we have :

Heat lost by the brass in cooling from 100° C. to 18° C.

$$= 95.4 \times (100 - 18) \times s \text{ calories, and}$$

Heat gained by the water and calorimeter in rising from 14° C. to 18° C.

$$= 204 \times 4 \text{ calories.}$$

Then if there is no other loss or gain of heat we get the following equation :

$$95.4 \times 82 \times s = 204 \times 4$$

whence

$$s = .10.$$

In this experiment the arrangements for heating the brass tube, and for its transfer to the calorimeter, are evidently not satisfactory. The brass may carry water with it, and it may cool several degrees during the time of transfer.

92. Heater for specific heat work.

From what has been said it will be clear that for accurate determinations of specific heat a good form of heater is necessary. The following simple arrangement has been found useful for elementary laboratory work. A tin can about 6" long and 4" diameter (Fig. 78) is provided with a loose lid B, pierced by a large central hole and two or three smaller ones about $\frac{1}{4}$ " diam. near the edge. A tin tube C about 5" long and $1\frac{1}{2}$ " diameter is provided with a flange D, which when the tube hangs within the can rests on the lid B.

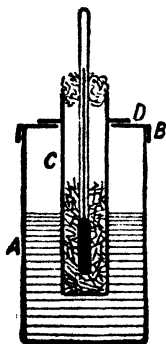

Fig. 78.

The substance to be heated should be broken into small pieces.† A known mass of it is placed in the tube and heated by steam from a

* The water equivalent of a calorimeter is equal to and is usually taken as the product of its mass (in gm.) and the specific heat of the material of which it is composed. The method of Exp. 45 does not yield very accurate results.

† This is not necessary if it is a good conductor.

small quantity of water kept boiling in the can. Place a thermometer with its bulb well in contact with the substance, and plug the open end of it with a piece of cotton-wool. When this temperature is steady for at least five minutes the tube is lifted out by means of a pair of clips, and the substance rapidly transferred without splashing to the water in the calorimeter. The water is then stirred and the maximum temperature read.

The form of heater in general use, however, is that shown in Fig. 79. This is usually made of copper and covered with thick felt. It consists of two concentric cylinders. A current of steam from a boiler is passed through the space between the cylinders. The interior of the inner cylinder is thus a steam oven and objects suspended in it can be heated to nearly 100°C . The method of using this heater is sufficiently indicated in the figure.

Fig. 80 shows the form usually known as Regnault's calorimeter. The calorimeter in its shielding box slides along grooves cut in the base of the framework. While the body is heating in the steam-heater a sliding shutter prevents transference of heat from the heater to the calorimeter. When the body has reached

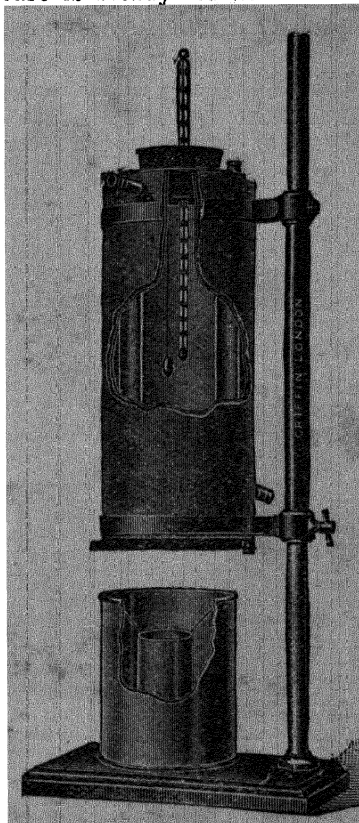

Fig. 79.

the temperature of the heater this sliding shutter is raised and the calorimeter is pushed below the heater. The body is then lowered into the water without splashing, the calorimeter quickly slid back into its original position, and the shutter lowered. The water is then slowly and cautiously stirred. The temperature rises at first quickly

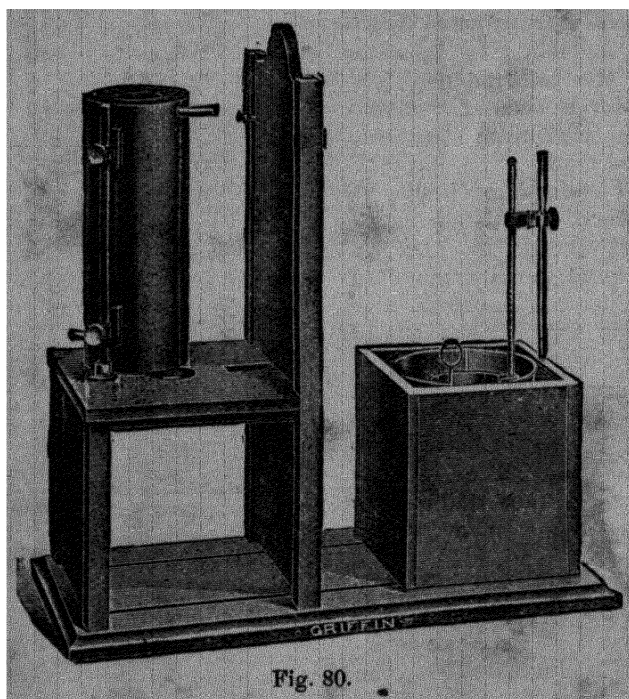

Fig. 80.

and then more slowly, coming at length to a standstill, after which it gradually falls as the whole apparatus cools. It is this maximum temperature that is read.

93. Calculation of the specific heat. While the hot body is giving out heat to the water, the calorimeter, thermometer, and stirrer all receive their share. Except

in very accurate work the water equivalent of the thermometer is neglected, and, as the calorimeter and stirrer are usually made of copper, the specific heat of which is 0.95, their combined water equivalent is equal to .095 times their combined mass. The number representing the water equivalent is then considered to represent the same number of grammes of water.

Hence, to take a general case, if M gm. of a substance of specific heat S are heated to $T^{\circ}\text{C}$. and dropped into m gm. of water placed in a calorimeter of mass m_1 (including the stirrer) and specific heat s_1 , all at temperature t , and if θ denote the final temperature, we have

$$\text{Loss of heat by given substance} = MS(T - \theta) \dots\dots(1)$$

Gain of heat—

$$\left. \begin{aligned} (1) \text{ By water} &= m \times 1 \times (\theta - t) \\ (2) \text{ By calorimeter and stirrer} &= m_1 \times s_1 \times (\theta - t) \end{aligned} \right\} \dots\dots(2)$$

Hence, assuming that no heat is lost to or received from the surroundings, the loss of heat by the hot substance must be equal to the gain of heat by the water, calorimeter, and stirrer.

Therefore, equating (1) and (2), we have

$$\begin{aligned} MS(T - \theta) &= m(\theta - t) + m_1 s_1(\theta - t) \\ &= (m + m_1 s_1)(\theta - t), \end{aligned}$$

from which S can be calculated if all other quantities are known.

NOTE.—This formula and the succeeding ones must be regarded merely as shorthand expressions for the various amounts of heat lost and gained by the various bodies. On no account must they be learnt by heart. Problems must be worked out as in the examples below.

Example. Find the specific heat of aluminium from the following data (obtained in an actual experiment):—

A lump of aluminium of mass 72.66 gm. was heated to 100.2°C . and then dropped into 158.0 gm. of water at 10.7°C . contained in a copper calorimeter provided with a copper stirrer, the combined mass of calorimeter and stirrer being 89.6 gm. The final temperature was 18.4°C . (the air temperature was 14°C .)

Denote the specific heat of aluminium by S ; then loss of heat by aluminium

$$= 72.66 \times S \times (100.2 - 18.4) \text{ calories} \dots\dots\dots(1)$$

The water equivalent of calorimeter and stirrer = $89.6 \times .095$, or 8.5 gm.;
 \therefore equivalent total mass of water = $158.0 + 8.5$, or 166.5 gm.

The heat gained by this equivalent mass of water
 $= 166.5 \times 1 \times (18.4 - 10.7) \text{ calories} \dots\dots\dots(2)$

Equating (1) and (2), we have

$$72.66 \times S \times 81.8 = 166.5 \times 7.7;$$

$$\therefore S = .215.$$

Exp. 51. Find the specific heat of bronze by the method of mixtures.* Take 4 or 5 halfpennies, bore holes through them near their edge, and tie together by string. Heat as explained. They can be used as their own stirrer.

Exp. 52. Find the specific heat of the following solids by the method of mixtures: *—iron nails (150 gm.), brass nails (150 gm.), lead shot (300 gm.), pieces of glass rod and tube (100 gm.), etc.

94. Specific heat of a liquid. The specific heat of a liquid may also be found by the method of mixtures. Two modifications of the method are in common use:—

(a) Enclose the liquid in a thin vessel (metallic by preference): raise it to a temperature T , drop it into water, and proceed as before. In calculation allowance must be made for the heat given out by the vessel. Thus, if M and S of the above relate to the contained liquid, m_2 and s_2 to the vessel, the other letters remaining the same, we have

$$(MS + m_2s_2)(T - \theta) = (m + m_1s_1)(\theta - t),$$

from which S can be found if s_1 and s_2 are known.

If the liquid is cheap and no chemical action occurs between it and the water it may be heated in a beaker and poured directly in the water.

* Several determinations of the specific heat of each substance should be made until there is approximate agreement in the results obtained.

(b) Place the liquid whose specific heat is required in the calorimeter; drop into it a known mass of solid of known specific heat and of known high temperature, and proceed as before. If, now, M, S, T relate to the solid, m, s, t and m_1, s_1, t_1 to the liquid and calorimeter respectively, we have

$$MS(T - \theta) = (ms + m_1s_1)(\theta - t),$$

whence s can be calculated.

Example. 100 gm. of copper (sp. ht. .095) were heated to 100°C . and dropped into 200 gm. of turpentine in a calorimeter (of water equivalent 4 gm.) at 15°C . The final temperature was 23°C . Find the specific heat of turpentine.

Let s = mean specific heat of turpentine between 15°C . and 23°C . We have

$$100 \times .095 \times (100 - 23) = (200 \times s + 4)(23 - 15),$$

$$\therefore \frac{95 \times 77}{8} - 4 = 200s,$$

$$\therefore s = .44.$$

Exp. 53. Find the specific heat of the following liquids by the method of mixtures: *—Methylated spirit, petroleum, alcohol, glycerine, etc. Adopt method (b) above and use iron (nails) as the solid.

95. The cooling correction in calorimetric experiments. It will have been noticed that in all calculations from the data of a calorimetric experiment it has been assumed that there is no loss or gain of heat by the calorimeter to or from its surroundings. In all actual experiments, however, the calorimeter is subject to a small loss or gain of this kind. As already explained, the construction of the calorimeter is designed to reduce this loss or gain of heat to a minimum. But in all experiments it is desirable to make a correction for this source of error. In most experiments the calorimeter is hotter than its surroundings, and the error is due to cooling during the experiment.

* Several determinations of the specific heat of each substance should be made until there is approximate agreement in the results obtained.

For this reason the correction is sometimes called the cooling correction, but the principle of correction is the same whether it has to be applied on account of the loss or gain of heat during the experiment.

One very simple way of making this correction is due to Rumford. The experiment is arranged so that the average temperature of the calorimeter during the experiment is the same as the temperature of its surroundings. When this is done the loss of heat while the calorimeter is hotter than its surroundings roughly compensates for the gain of heat when it is colder than its surroundings. It is obvious, however, that to arrange the experiment in this way it may be necessary to make one or two trial experiments.

Example. Suppose that in a specific heat determination the temperature of the calorimeter surroundings is 14°C ., and that in a trial experiment a rise of 4 degrees is obtained in the calorimeter. Then, in order to adjust for this method of correction, the initial temperature of the water in the calorimeter should be adjusted to 12°C . The highest temperature reached will then be about 16°C ., and the mean temperature during the experiment about 14°C .*

96. Determination of specific heat by the method of cooling. This method is occasionally employed for the determination of the specific heat of liquids. If a given mass of liquid, at a known temperature, be placed in a vessel and allowed to cool in an enclosure (or room) at a lower temperature than its own, then it is found by experiment (see Exp. 159) that the rate of loss of heat depends only upon—

(1) The difference of temperature of the liquid and the enclosure (or room).

* Even this is not quite correct, for on "mixing" the rise of temperature with time is not uniform, but rises more quickly during the first half of the rise than during the second half. The method is therefore only approximate. A better method is to read the temperature of the water every quarter minute after the hot body is put into it until the water has passed its maximum temperature and is cooling. From the curve obtained a fairly accurate correction may be applied. Full details are, however, beyond an elementary book.

(2) The nature and extent of the surface at which cooling takes place (Ch. XIV.).

The heat lost is therefore independent of the nature of the liquid, so that if different liquids are allowed to cool under exactly the same conditions (as defined in 1 and 2) they will lose heat at the same rate.* This is the principle applied in the method of cooling.

To determine, by this method, the specific heat of a given liquid, a known mass of the liquid at a temperature of about 60° C. is placed in a calorimeter provided with a thermometer. The calorimeter and the vessel surrounding it are covered by a lid with a small hole in it for the thermometer stem, and, in order to maintain the surrounding temperature constant, the apparatus is placed in the interior of a double walled metal vessel, the space being the walls containing water at the temperature of the room (see outer vessel of Fig. 121). The cooling, which now goes on slowly, is carefully watched, and the time of cooling through a given range of temperature, say, from 50° C. to 40° C., is noted.

The liquid is then removed from the calorimeter and replaced by an equal volume of water, of known mass, raised to about 60° C. The experiment is repeated, and the time of cooling through the same range (50° C. to 40° C.) is noted. We have now sufficient data for calculating the specific heat of the liquid. Let m be the mass of the liquid, and t its time of cooling from 50° C. to 40° C., m' the mass of the water, and t' its time of cooling from 50° C. to 40° C., also let w denote the water equivalent of the calorimeter, etc. Then, for heat lost during cooling of liquid we have, if s denote the specific heat of the liquid—

$$\text{Heat lost by liquid during time } t = m s \times 10.$$

$$\text{,, ,, ,, calorimeter during time } t = w \times 10.$$

$$\therefore \text{Total loss} = (m s + w) 10,$$

$$\text{and rate of loss} = \frac{(m s + w) 10}{t}.$$

* The rate of fall of temperature will, of course, be different in each case.

Similarly, rate of loss of heat by water =

$$\frac{(m' + w) 10}{t'}$$

But, by the experimental laws of cooling we have—

$$\frac{(ms + w) 10}{t} = \frac{(m' + w) 10}{t'}$$

a relation from which we can calculate s .

It is to be noted that the specific heat here determined is the mean specific heat for a particular range of temperature (50°C. to 40°C. in this case) and is relative to the mean specific heat of water for the same range of temperature. If the range of temperature is short, the method practically gives the specific heat at the average temperature of the range, relative to the specific heat of water at the same temperature.

Exp. 54. Find the specific heat of petroleum oil by the method of cooling. As a calorimeter use a thin copper or iron canister coated with lampblack* on its outer surface. Cut two holes in the lid for the thermometer and stirring rod. Support on a cardboard cross (Fig. 81) inside a box of cardboard or wood of about 1 ft. each way, or a large metal canister whose inner surface is coated with lampblack. This box prevents draughts, facilitates cooling, and supplies an enclosure of almost constant temperature.

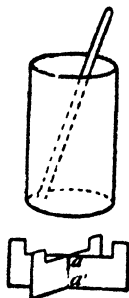

Fig. 81.

Weigh the calorimeter, two-thirds fill it with hot water, insert the thermometer and stirrer, place within the box, and observe the time of cooling through 10°C. (say from 60°C. to 50°C. , 50°C. to 40°C. , 40°C. to 30°C.). Then remove and weigh, thus getting m' . Heat a sufficient quantity of petroleum in a large test-tube immersed in hot water. Avoid a flame. Fill the calorimeter up to the same level as before

* Instead of using lampblack the calorimeter may be varnished dead black. This varnish is made by mixing vegetable black with methylated spirits and adding a little shellac varnish.

with the hot petroleum. Note the times of cooling for the same ranges of temperature. When cold find the mass of the petroleum. Compare the results for the same ranges of temperature, and so calculate the specific heat of petroleum.

Example. Determine the specific heat of petroleum from the following experimental results:—

Mass of calorimeter (of sp. ht. 1) = 44.6 gm., mass of water = 124.1 gm., mass of petroleum 95.6 gm. Time of cooling from 55° to 50° was 410 sec. for water and 195 sec. for petroleum.

$$\text{Then} \quad \frac{124.1 + 4.5}{410} = \frac{95.6s + 4.5}{195};$$

$$\therefore 128.6 \times 195 = 410 \times 95.6s + 410 \times 4.5,$$

whence $s = .59.$

Exp. 55. Find, by the method of cooling, the specific heat of alcohol, glycerine, castor oil, aniline, etc.

97. Specific heat of gases. Regnault made careful determinations of the specific heat of various gases. The gas was collected into a reservoir, and then heated to a high temperature by passing it through a long spiral tube immersed in an oil bath. It then passed through a calorimeter where it was cooled to the temperature of the surrounding water, and then escaped into the air. The rise of temperature in the calorimeter was noted, and the mass of gas which had passed through was determined by the change of pressure in the reservoir. On equating the loss of heat of the gas to the gain of heat of the calorimeter and the contained water the specific heat may be found as in the "method of mixtures" before.

Since the temperature of the calorimeter gradually rises during the experiment, the first traces of gas experience a larger fall in temperature than the last traces, and hence, when calculating the loss of heat by the gas, the average fall in temperature must be multiplied by the mass of the gas. Thus, for example, if the temperature of the oil-bath is 200° C., and the original and final temperatures of the calorimeter are 10° C. and 20° C., the average fall in temperature is

$$\left(200 - \frac{10 + 20}{2}\right) \text{ or } 185^\circ \text{ C.}$$

Regnault established the following results:—

1. The specific heat of a gas at constant pressure is the same whatever that constant pressure may be.

2. All simple gases of similar molecular structure* have, at the same pressure, the same thermal capacity per unit volume.

3. The specific heat is the same at all temperatures.

The results only hold true for the nearly "perfect" gases. There is considerable departure from them in the case of gases which are far from perfect.

It should be noticed that gases have two specific heats, according as they are heated at constant pressure and allowed to expand (specific heat at constant pressure) or at constant volume without expansion (specific heat at constant volume). The specific heat at constant pressure is greater than the specific heat at constant volume, because, not only has the temperature of the gas to be raised, but a quantity of heat, equivalent to the work done during the expansion against the external pressure, has to be supplied to the gas (see Art. 245).

The specific heats of gases at constant pressure have also been found by a continuous electric method. A constant stream of gas was forced through a tube into a jacket where it was heated by an electric current flowing through a coil of platinum wire. The temperatures of the gas before and after passing through the jacket were measured accurately by platinum thermometers (Art. 265), and from these, together with a knowledge of the heat supplied by the electric current (Art. 248) and the rate of flow of the gas, the specific heat could be calculated.

The determination of the specific heat at constant volume will be described in Art. 165.

98. Other methods of finding specific heats. Several other methods of determining specific heat, which depend upon a knowledge of latent heat, will be considered later.

* The difference of the specific heats, per given volume, is the same for all perfect gases (Art. 245). The ratio of the specific heats is about 1.67 for a monatomic gas like helium or argon, and about 1.4 for a diatomic one like hydrogen, oxygen, and nitrogen. The elementary permanent gases used by Regnault were all diatomic,

TABLE OF SPECIFIC HEATS.

Solids.		Liquids.	
Lead	·031	Mercury	·033
Tin	·055	Turpentine	·426
Brass	·094	Glycerine	·555
Copper	·095	Alcohol	·620
Zinc	·096		
Iron	·114	Gases (at constant pressure).	
Thermometer Glass ...	·198	Air	·24
Sulphur	·180	Carbon dioxide	·21
Aluminium	·214	Steam	·48
Ice (−78° C. to 0° C.)...	·474	Hydrogen	3·41

The specific heat of a substance depends upon the state—solid, liquid, or gas—of the substance. As a rule, the specific heat is greatest in the liquid state. (See table above for ice, water, and steam.)

99. Properties of a typical thermometric substance.

We are now in a position to consider this question more fully than in Ch. II. Assuming that we wish to indicate change of temperature by change of volume, the chief properties necessary to constitute the substance a typical one are:—

- (1) *Uniform expansion with increase of temperature.**
- (2) *A large coefficient of expansion; that is, the increase of volume for 1° rise of temperature should be sufficiently large to be capable of accurate measurement.*
- (3) *Low thermal capacity per unit volume.* When this is the case—together with (2)—the thermometer is very sensitive to loss or gain of heat.
- (4) *Constant specific heat at all temperatures.* A substance possessing this property would lose or gain equal quantities of heat for each degree change of temperature. For most substances the specific heat increases with the temperature.

(5) *The range of temperature, within which the above properties remain unchanged, should be as wide as possible.*

* This implies the existence of an absolute scale of temperature that does not depend upon the properties of any thermometric substance.

(6) *Its power of transmission of heat, either by convection or conduction (see Chs. VII., XIII.) should be great.* This insures rapid and uniform distribution of temperature throughout its substance.

The only substance possessing the above properties in the required degree is air, or one of the gases which closely follow Boyle's law, and, for this reason, the air thermometer is the most perfect instrument of its kind. The properties of mercury, between 0° C. and 100° C., very closely conform to those given above.

When a gas is used (3) and (4) above apply much more to the bulb of the thermometer than to the gas inside, for the bulb has much the larger water equivalent.

100. The specific heat of water. Regnault deduced from the results of a number of experiments made by him in 1847 that the mean specific heat of water between 15° C. and 100° C. was between 1.007 and 1.009 times the mean specific heat between 10° C. and 15° C. Hirn also experimented on the variation of the specific heat of water with temperature and adopted the method of supplying equal quantities of heat to water at different temperatures and noting the rise of temperature produced. The heat was supplied by allowing a water thermometer with a very large bulb to cool in the water through the same fixed range of graduations in each experiment. Jamin and Amaury also adopted in 1870 a similar method, but supplied the heat by passing an electric current through a spiral of metallic wire immersed in the water.

The general result of all these experiments was to indicate a gradual increase of specific heat with temperature. Formulae of the form

$$S = 1 + at + bt^2$$

were deduced from the results obtained, but there was no satisfactory agreement in the values assigned to the constants a and b by the different experimenters.

Rowland's experiments in 1879 on the value of the mechanical equivalent of heat (Art. 246) led to an investigation by him of the variation of the specific heat of water with temperature. The method adopted was the method

of mixtures as used by Regnault in the case of liquids, and the results probably give with some accuracy the true nature of the variation. Rowland found that the specific heat of water decreases to a minimum at about 30° C. and then increases.

Bartoli and Stracciati published in 1891 the results of some experiments which confirm Rowland's results and place the temperature of minimum specific heat at 20° C. Taking the specific heat at 15° C. as 1 they find the value at 0° C. to be about 1·007, at 20° C. ·9995, and at 30° C. 1·002.

Griffiths, in his electrical research on the value of the mechanical equivalent of heat in 1893, also investigated the variation of the specific heat of water and, taking the specific heat at 15° C. as unity, gives $1 - \cdot00027(\theta - 15)$ as the specific heat at any temperature between 14° C. and 26° C. The experiments were not extended beyond this range and do not give a temperature of minimum specific heat. Rowland's results for the same range of temperature can be expressed by $1 - \cdot0004(\theta - 15)$, but the value of the constant is not very certain and differs materially from that given by Griffiths.

Callendar and Barnes (1902) have also measured the variation of the specific heat of water from 0° C. to 100° C., the water being heated by an electric current. Taking the specific heat of water at 20° C. as 1·0000, they found that the specific heat at 0° C. was 1·0094, that as the temperature was raised it gradually dropped to a minimum value of ·9982 at 40° C., was again 1·0000 at 60° C., and rose to 1·0074 at 100° C.

The specific heat between 10° C. and 60° C. may be represented by the formula

$$S = \cdot9982 + \cdot000045(t - 40)^2.$$

The specific heat of water is thus very nearly constant over ordinary calorimetical ranges.

101. Effects of the high specific heat of water. Owing to its great specific heat, water absorbs much more heat in warming, and gives out much more heat in cooling, than

an equal weight of almost any other substance. Hence the value of water in hot-water pipes, foot-warmers, etc.

Now land is more easily heated or cooled than water, and also the prevailing temperature of an island is between that which the land would have if the water were absent and that which the water would have if the land were absent. Thus in summer, when the sun is above the horizon for a considerable time, the temperature of an island is lower than that of a continent; and in the winter, when the sun is above the horizon for a short time only, the temperature of an island is higher than that of the continent, *i.e.* the climate of an island is much more equable than that of continental countries in the same latitude (see also Art. 219).

102. The total quantity of heat possessed by a body. It should be noticed that in all calorimetric experiments we have to deal only with the quantities of heat which a body *gains* or *loses*, not with the total quantity of heat which a body possesses. For example, 100 grammes of copper in cooling from 100° C. to 20° C. *lose* about 80 units of heat, or in heating from 20° C. to 100° C. *gain* 80 units, but the total quantity of heat possessed by 100 grammes of copper at, say, 20° C. is a quantity which cannot be determined, for we do not know at what temperature copper may be said to have lost all its heat, neither do we know the average value of the specific heat of copper down to that temperature.

103. Atomic heats. In 1818, as the result of a series of researches, Dulong and Petit established the law that the specific heat of any element in the solid state is inversely proportional to its atomic weight. This important generalisation may be stated in an equivalent form by saying that the product of the specific heat of an element into its atomic weight is constant, the value of the constant being about 6.4. This product is known as the **Atomic Heat** of an element. Since, then, the thermal capacity of the atomic weight in grammes of *any* element is constant, and

since quantities equal to the atomic weights in grammes of any of the elements contain the same number of atoms, it follows that the atoms of the elements in the solid state have the same capacity for heat.

TABLE OF ATOMIC HEATS.

	Atomic Weight.	Specific Heat.	Atomic Heat.
Aluminium... ..	27	·214	5·8
Sulphur	32	·178	5·7
Iron	56	·114	6·4
Copper	63	·095	6·0
Zinc	65	·094	6·0
Tin	118	·055	6·5
Iodine	126	·054	6·8
Gold... ..	197	·032	6·4
Lead	206	·031	6·4
Uranium	239	·028	6·7

It is to be noted that the values for the atomic heat are not very constant, fluctuating from 5·7 to 6·8. This, however, is only to be expected, for the specific heat of a substance is a fairly complex quantity, the heat supplied going not only to raise its temperature, that is, to increase the vibratory movements of its molecules, but also to supply the energy necessary for forcing the molecules to greater distances apart, and, in the case of some substances (*e.g.* iron), to supply part of the latent heat of fusion, which, in those bodies that pass through a viscous condition, begins to be absorbed at temperatures which are far below the temperature which is usually taken as the melting point.

Moreover, in making comparisons, the specific heats should, as far as possible, be taken under similar conditions for the different bodies compared, and when, in making the comparison, we utilise the specific heats taken at ordinary temperatures of, say, lead and iron, lead having a M. Pt. of 327° C. and iron a M. Pt. of 1500° C., this condition can

hardly be said to be fulfilled. So that, all things considered, the agreement is as close as can be expected.

The elements carbon, silicon, and boron were long considered to be exceptions to this generalisation, their atomic heats being 1·8, 3·8, and 2·7 respectively, until Weber, thinking that the specific heats of these bodies had not been determined under proper conditions, instituted a research into the variation with temperature of the specific heat of each of them, and found that as the temperature was raised the specific heat in every case approached a limiting value, which gave for the atomic heat a sufficiently close approximation to the mean value 6·4. The various researches on the atomic weight of beryllium show that the specific heat of this metal also increases with rise of temperature to a limiting value, and furnish an interesting illustration of the importance of this fact in any application of the law of atomic heat to the determination of atomic weight.

It is interesting to note that the specific heat of solid hydrogen has lately been directly determined, and has been found to be equal to 6, which is about the value necessitated by Dulong and Petit's law.

Example. The atomic weight of uranium has been shown by chemical analysis of the chloride of uranium to be some multiple of 60. The specific heat of uranium is 0·028. What is the atomic weight?

Taking 60, 120, 180, 240 as possible values of the atomic weights we find the atomic heats to be 1·68, 3·36, 5·04, 6·72. It is evident that 240 is the correct atomic weight.

104. Molecular heat. Neumann, and, later, H. Kopp, Regnault, and Woestyn extended these observations to compound molecules, for, calling the product of the specific heat into the molecular weight the molecular heat, they showed that in many cases the molecular heat of a compound was the sum of the atomic heats of its constituent atoms. This gives us a means of finding the specific heats of elements in the solid state which cannot readily be determined directly. Thus, if we know the molecular heat of potassium chloride, and subtract therefrom the atomic heat of potassium, we obtain the atomic heat of chlorine. Dividing this by the atomic weight of chlorine, we obtain the specific heat of chlorine in the solid state.

EXERCISES VIII.

1. What is meant by *unit of heat*? If the specific heat of iron is $\frac{1}{8}$, and 1 lb. of iron is cooled down from the temperature of boiling water to the temperature of melting ice, how many units of heat are evolved?

2. Ten gm. of water at 98.0°C . are poured into a copper vessel weighing 25 gm. and containing 100 gm. of water at 6.0°C . Find the final temperature of the mixture. Specific heat of copper = 0.092.

3. In order to determine the specific heat of silver, a piece of the metal, weighing 21 gm., is heated to 98°C . and then dropped into a calorimeter containing 100 gm. of water at 10°C . The final temperature of the mixture is 11°C .; find the specific heat of silver. The water equivalent of the calorimetric apparatus is 3.6 gm.

4. Ten gm. of common salt at 91°C . having been immersed in 125 gm. of oil of turpentine* at 13°C ., the temperature of the mixture was 16°C . Find, from these data, the specific heat of common salt, supposing no loss or gain of heat to have taken place from without and taking the specific heat of oil of turpentine as 0.428.

5. A mass of 200 gm. of copper, whose specific heat is 0.095, is heated to 100.0°C ., and placed in 100 gm. of alcohol at 8.0°C ., contained in a copper calorimeter, whose mass is 25 gm., and the temperature rises to 28.5°C . Find the specific heat of the alcohol.

6. The following data were obtained in an experiment for the determination of the water equivalent of a given calorimetric apparatus.

Weight of apparatus	45.623 gm.
" " " + water	224.583 "
Initial temperature of apparatus and water	9.0°C .
Temperature of hot water	78.0°C .
Final temperature	13.2°C .
Weight of apparatus after addition of hot water	236.493 gm.

[*Note.*—These data are given in the order of their determination in an actual experiment.]

7. A ball of platinum, whose mass is 200 gm., is removed from a furnace and immersed in 150 gm. of water at 0°C . If we suppose the water to gain all the heat which the platinum loses, and if the temperature of the water rises to 30°C ., what is the temperature of the furnace? Specific heat of platinum is 0.031.

[This example indicates a method of measuring very high temperatures.]

* Water could not be used in this case, as common salt is soluble in water. This point should be noticed.

8. Determine the specific heat of bronze from the following data obtained from an experiment with four halfpennies:—

Weight of bronze	21.30 gm.
„ calorimeter (copper, sp. ht. = .095)	52.97 gm.
„ water in calorimeter	105.73 gm.
Initial temperature of the bronze	99.5° C.
„ „ water and calorimeter	17.0° C.
Final „ mixture	18.5° C.

9. Determine the specific heat of alcohol from the following data:—

Weight of copper calorimeter	20.4 gm.
„ „ + alcohol	70.5 „
„ „ dropped into calorimeter	10.5 „
Initial temperature of calorimeter and alcohol	10.0° C.
„ „ copper	98.0° C.
Final „ mixture	12.6° C.

10. Regnault found that 100.5 units of heat were required to raise the temperature of unit mass of water from 0° C. to 100° C., and 203.2 units to raise its temperature to 200° C. Find the mean specific heat of water between 0° C. and 100° C., between 100° C. and 200° C., and between 0° C. and 200° C.

11. 9 gm. of hydrogen at 0° C. were first heated to 210° C. and then passed through a calorimeter whose water equivalent was 5 gm., and which contained 500 gm. of water. Its temperature was initially 10.0° C. and finally 22° C., and it was estimated that 36 calories were lost by cooling during the passage of the gas. Find the specific heat of hydrogen.

12. In a determination of the specific heat of turpentine by the method of cooling, the weight of the calorimeter (copper) = 38.0 gm.; its weight containing the turpentine = 87.4 gm., and containing water = 94.7 gm. The times of cooling for the successive 5° C. from 70° C. to 55° C. were 80, 92, and 105 secs. with the turpentine and 179, 201, and 233 secs. with the water. Specific heat of copper is .095. Find the mean specific heat of turpentine.

13. Equal volumes of two liquids A and B are mixed. Find the final temperature.

Specific gravity of A = 1.8; of B = .56.

Specific heat of A = 0.3; of B = 0.6.

Temperature of A = 60° C.; of B = 40° C.

14. The specific heat of iron is .114. What is its approximate atomic weight?

CHAPTER IX.

THE LOWER CHANGE OF STATE.

LIQUEFACTION AND SOLIDIFICATION.

105. Liquefaction and Solidification. In Art. 9 attention was called to the fact that most bodies may exist in three states—solid, liquid, and gas—the application or withdrawal of heat being all that was necessary to change a body's state.

These changes of state take place under the influence of heat in all elementary substances, but the temperatures of liquefaction and vaporisation for different substances are widely different, and in some substances our means of producing heat and cold are too limited to effect the changes. Thus, iron melts at a very high temperature, platinum at a still higher, and although carbon has been somewhat softened it has not been thoroughly liquefied. On the other hand, many gases condense only at very low temperatures and solidify at temperatures much lower, and it is only in recent years that the so-called permanent gases, oxygen, hydrogen, nitrogen, air, helium, etc., have been liquefied, and, in some cases, solidified.

Although our range of observation is thus somewhat limited by our means of producing heat and cold, yet we have sufficient, and continually increasing evidence that every elementary substance exists in three states—the solid, liquid, and gaseous, though the range of temperature corresponding to any particular state is very different for different substances. When we speak of a substance as a

solid, liquid, or gas we refer to its condition at ordinary temperatures.

This chapter deals solely with the change from solid to liquid, and its reverse, the change from liquid to solid. When a solid substance changes, on heating, from the solid state to the liquid state the process of change is known as *liquefaction* or *fusion* or *melling*. On the other hand, when a liquid substance, on cooling, changes from the liquid state to the solid state the process of change is known as *solidification* or *freezing*.

106. Temperature and change of state. The object of the following experiments is to determine whether or not, during change of physical state, there is any change of temperature.

Exp. 56. Fill a large beaker with small pieces of ice or ice shavings and insert a thermometer. The temperature is 0° C. As the ice is heated and stirred so as to secure uniformity of temperature the thermometer shows no change until the *whole* of the ice is melted. That is, during the change from a solid—ice—to a liquid—water—there is no change of temperature until the change is complete, and during the change the water and ice are at the same temperature. If this experiment be repeated a number of times it will be found that the change always takes place at the same temperature. The constant temperature at which this change of state, from the solid to the liquid, takes place is known as the *melting point* of the solid or the *freezing point* of the liquid.

This experiment indicates an important law of liquefaction. The law may be stated as follows:—During the liquefaction of a substance the temperature remains constant at a fixed temperature, which is different for different substances. This temperature for any substance is known as the *melting point* of that substance.

If after a solid mass is melted the heating is still continued the temperature of the liquid rises in the usual way. Also if the liquid is cooled until the substance assumes the solid state the temperature changes during cooling and solidification will be found to be an exact reversal of the changes observed during heating and liquefaction. That is, the temperature falls until solidification begins, then

remains constant at a fixed point until solidification is complete, and then falls in the ordinary way. Also the constant temperature of solidification is observed to be exactly the same as the constant temperature of liquefaction. This temperature for any substance is sometimes called the **freezing point** for that substance. The **freezing point** is identical with the **melting point**.

107. Change of volume during change of state. The object of the following experiments is to determine if the volume of a given mass of a substance changes with change of state.

Exp. 57. Fill a glass bulb with water and seal up the bulb with the blowpipe. Place the bulb in a freezing mixture (Art. 118), so that the water in the bulb freezes. It will be found that the bulb or shell is burst open, thus showing that the ice formed is appreciably greater in volume than the water. In this case, therefore, there is an *increase* of volume in changing from the liquid to the solid state.

Exp. 58. Melt some paraffin wax and pour it into a beaker. When it solidifies the surface will show a considerable depression, indicating that the volume of the solid wax is appreciably less than that of the liquid wax. In this case, then, there is a *decrease* of volume in changing from the liquid to the solid state.

The results of Exps. 57 and 58 show that a change in volume accompanies change of state from solid to liquid, but that for some substances it is an increase of volume, while for others it is a decrease of volume.

Further experiments with the water-ice change:—

Exp. 59. Take a piece of ordinary "compo" tubing, fill it with water and close both ends securely. When exposed to a low enough temperature the water freezes and bursts the pipe.

Exp. 60. Nearly fill a 4-oz. flask with ice broken up small, and add water to fill the interstices of the ice. Mark the water level near the top of the neck by an elastic band. Then melt the ice by gentle heat, and note the gradual fall of the water level,

108. Change of volume in melting. As a general rule, bodies expand in the act of melting and contract on solidification. In the case of phosphorus this expansion on fusion amounts to 3·4 per cent., sulphur 5 per cent., and stearic acid 11 per cent. This accounts for the fact that when any of these substances are cast in glass tubes they contract away from the glass and easily fall out when solid.

But a few substances, such as water, cast iron, bismuth, contract in melting and expand in solidifying.

109. The expansion of water in freezing amounts very nearly to 9 per cent., so that 11 volumes of water at 1° C. become about 12 volumes of ice at the same temperature. Consequently ice floats in pure water with about $\frac{1}{12}$ of its volume above the surface. If the water is confined, it exerts great force by its expansion on freezing, and thus *in the act of freezing* bursts water bottles and pipes. In the case of pipes the damage does not, however, become *apparent* until a thaw melts the plug of ice that has been forced into the rent, and so allows the water to escape.*

Much damage is done to brick and stone work by similar means. Rain or moisture from the earth penetrates the bricks, and on freezing forces the particles asunder. Then, after a thaw, the face of the wall shows evident signs of the destruction. On the other hand, the action of frost benefits the farmer by breaking down the rough clods left by the plough into a fine seed bed. Indeed, the origin of the soil from the subjacent rock is largely due to long continued action of this kind.

If a small cast-iron bottle, with sides half an inch or more in thickness, is filled with water and tightly closed by a screw and then placed in a freezing mixture of ice and salt (§ 118), the bottle will burst asunder as soon as the water freezes.

* A circle is the plane figure which for a given perimeter has the maximum area. If therefore a pipe of elliptical cross section is subjected to internal pressure it may accommodate itself to the pressure by altering its shape of cross section to circular. For this reason Professor Boys has suggested that exposed water pipes should be elliptical in section,

If water contracted on freezing, the ice as it formed would sink to the bottom, exposing a fresh layer of water to the cold air; thus a spell of cold weather would convert our rivers, lakes, and pools into blocks of solid ice.

A lump of cast iron floats on the liquid metal just as ice does on water, and an iron casting owes its sharpness to the expansion which takes place in solidifying, and which forces the metal into intimate contact with every part of the mould. A casting in copper or silver is much less sharp, because these metals contract on solidification.

110. The viscous state during fusion. In studying the change from the solid to the liquid state, it is of interest to determine whether the change takes place abruptly or gradually.

Exp. 61. Melt some lead in an iron ladle and note that the change from the solid to the liquid state is apparently quite sharp and abrupt.

Exp. 62. Melt some pitch or sealing-wax in a porcelain crucible and note that the change from solid to liquid is gradual and that the substance passes through an intermediate *viscous* state.

Exp. 63. Heat a piece of glass tubing in the blowpipe flame. The glass quickly softens and assumes a viscous state. If further heated under proper conditions it would melt to a clear mobile liquid.

A number of substances, solid at ordinary temperatures, such as glass, iron, etc., behave in this way when melting. Similarly, a number of substances, liquid at ordinary temperatures, such as glycerine, acetic acid, and some other organic acids and oils, pass through an intermediate viscous state in passing from the liquid to the solid state. For these substances the melting point, that is the temperature at which melting takes place, is indefinite, for the process really extends over a range of temperature which varies with the substance. For other substances for which the change of state is sharply defined, the melting point is fixed and definite and characteristic of the substance,

111. Determination of the melting point of a substance. The methods of determining the melting point of a given substance depend on the nature of the substance—for example, the determination of the melting points of mercury and glass would require somewhat different methods, both because the temperatures are widely different and because the nature of the change of state is different in the two cases. We shall describe methods which are applicable where the melting point is definite and lies between 0°C. and 100°C. , and for convenience of description we shall assume the substance under treatment is paraffin wax, which melts at about 52°C.

Exp. 64. Melt some wax in an evaporating dish and dip the bulb of the thermometer in. When the indicated temperature is about 60°C. remove the thermometer and hold the bulb in the air. At first the bulb is covered with a thin transparent layer of melted wax; as it cools a point arrives at which the wax solidifies, giving the bulb a frosted appearance. At once read the temperature. This is the melting point.

Repeat several times, removing the thermometer from the liquid at temperatures nearer and nearer the melting point.

Exp. 65. Extend Exp. 64 by placing a beaker of water over a Bunsen burner, and after each solidification stir the water gently with the thermometer and light the burner. Note the temperature at which the film becomes transparent. The mean of the two readings gives the melting point.

The following results were observed in such an experiment:—

Film becomes frosted on cooling.			Film becomes transparent on heating.			Mean.
52.0°C.	52.3°C.	52.2°C.
52.1°C.	52.5°C.	52.3°C.

\therefore Melting point = 52.2°C.

Exp. 66. Heat some $\frac{1}{2}$ cm. bore glass tubing in the blowpipe flame and pull it out to form capillary tubing of about $\frac{1}{2}$ mm. diam. and with very thin walls. Break it up into 10 cm. lengths. Melt some wax in a dish and suck up about 5 cm. of wax into the capillary tubes. Now seal the lower ends of the tubes. Attach such a tube by an

indiarubber band to the bulb and lower part of the thermometer as in Fig. 82, and mount the thermometer so that the bulb and tube dip into a large beaker of water with the top of the wax just below the surface. Gently heat the water, stirring it all the time.

At a certain stage the opaque solid will suddenly change to a transparent liquid; note the temperature. It is the approximate melting point. Now remove the burner and, keeping the stirrer going, observe the temperature when the wax becomes opaque (*i.e.* solidifies). The mean of the two readings should give a result somewhere near the truth. Repeat the heating and cooling two or three times, the temperatures not being allowed to depart more than 5° from the melting point, and the changes in temperature being more gradual.



Fig. 82.

The following results were obtained in such an experiment:—

Temp. rising. Melting occurs at—		Temp. falling. Solidification occurs at—			Mean.
53.5°C.	...	52.3°C.	52.9°C.
53.5°C.	...	51.5°C.	52.5°C.
\therefore Melting point = <u>52.7°C.</u>					

The results from this method are not very good, because melting and solidifying are sometimes delayed in a very narrow tube.

Find if it is necessary to allow for stem exposure of the thermometer (see Art. 22, 4).

By using paraffin wax, or glycerine, or sulphuric acid in a suitable bath the method of Exp. 66 may be extended to temperatures much higher than 100°C.

Method of Cooling. When a substance is melted and allowed to cool the temperature falls gradually until the freezing point is reached. At this point the temperature remains steady until all has solidified. After this the temperature once more falls.

Exp. 67. Place the wax in a small copper calorimeter or copper tube, melt it and introduce a thermometer into the liquid. Then place the tube inside a beaker * to protect it from air currents, and observe the temperature at regular intervals (say every quarter of a minute) as the

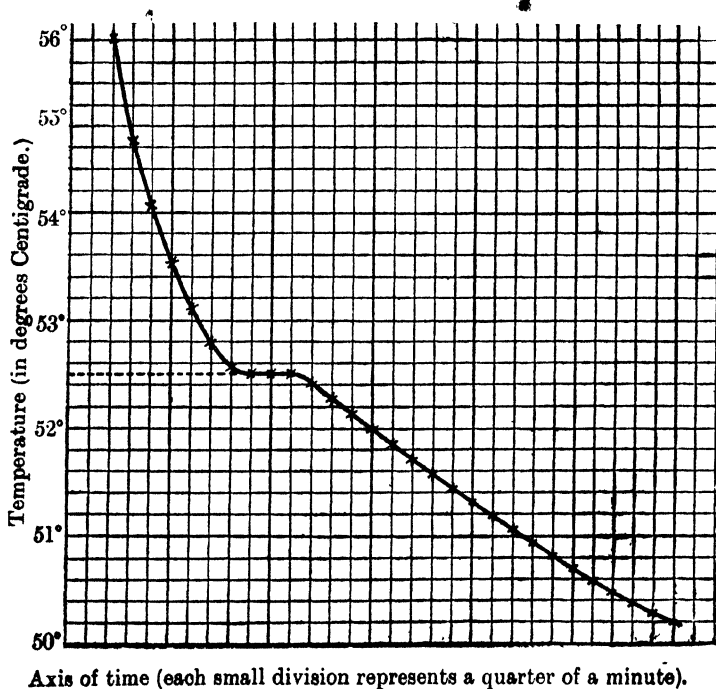

Fig. 83.

wax cools. Plot a curve (Fig. 83) in which times are abscissae and temperatures are ordinates. The temperature at which the curve runs most nearly parallel to the axis of time is the melting point. Fig. 83 represents a curve drawn from an actual experiment with paraffin wax.

* The apparatus used in the determination of specific heats by the method of cooling is very suitable for this experiment.

From it the melting point is seen to be 52.5°C . This method is the most reliable one when it can be used. If the substance is not pure there may be more than one melting point and the curve may run nearly parallel to the axis of time at two or more places.*

112. Melting point of metals and alloys. By using suitable baths and thermometers the methods of Exps. 66 and 67 may be extended to temperatures much higher than 100°C . If Exp. 67 is adopted a quick acting thermometer is required and metallic electrical instruments (thermo-couples or resistance thermometers, Arts. 265, 266) are then usually employed.

When alloys are melted and allowed to cool the curve obtained often shows more than one horizontal position. Each of these marks the melting point of one of the metallic constituents, or of a stable alloy formed between two of them.

Some alloys melt at a much lower temperature than their constituents melt. Thus Wood's fusible alloy, composed of bismuth 4 parts, lead 2 parts, tin 1 part, cadmium 1 part, melts at 65°C ., and an alloy of two parts of sodium to one of potassium is liquid at ordinary temperatures.

TABLE OF MELTING POINTS.

Platinum.....	1710°C .	Potassium sulphate	1070°C .
Pure iron.....	1500°C .	Borax	1000°C .
Copper.....	1083°C .	Common salt	800°C .
Gold.....	1082°C .	Anthracene.....	230°C .
Silver	961°C .	Tartaric acid	167°C .
Aluminium.....	657°C .	Cane Sugar.....	161°C .
Zinc.....	419°C .	Sulphur	115°C .
Lead.....	327°C .	Naphthalene	80°C .
Cadmium	321°C .	White wax.....	68°C .
Bismuth	267°C .	Paraffin wax	54°C .
Tin	232°C .	Phosphorus.....	44°C .
Sodium	90°C .	Benzene	6°C .
Mercury	-39°C .	Ice	0°C .

* Paraffin wax is not as suitable for this experiment as, say, naphthalene (m. p. 80°C .) owing to the fact that paraffin wax is really a mixture and has not a very definite melting point. Naphthalene is sold very cheaply in the form of balls to keep away moths.

113. A **meldometer** is an instrument which measures temperature by means of melting points. Thus, if a porcelain plate carrying lumps of lead and cadmium was put into a furnace for some time and the lead did not melt while the cadmium did, it would follow that the temperature of the furnace was between 327°C . and 321°C .

114. **Influence of pressure on the melting point.** The influence of pressure on the melting point of a substance may be deduced from theoretical considerations, and was first stated by Professor James Thomson. The nature of this influence is as follows:—

(a) If a substance *contracts in melting*, as in the case of ice, increase of pressure causes a *lowering* of the melting point of the substance.

(b) If a substance *expands in melting*, as in the case of wax, increase of pressure causes a *rise* of the melting point of the substance.

James Thomson calculated that, in the case of ice, the melting point is lowered by about $\cdot0073^{\circ}\text{C}$. for one atmosphere increase of pressure. This was experimentally confirmed by his brother, Lord Kelvin.

In the case of ice, which we have seen belongs to the former class of substances, we can illustrate the influence of pressure experimentally.

Exp. 68. Perform Faraday's experiment on regelation. Take two pieces of ice and press them together for a few seconds; on relieving the pressure the two pieces are found frozen together at the region of contact. The pressure enabled a thin layer of the ice to melt by lowering the melting point; on relieving the pressure the water thus formed immediately froze again. This phenomenon is known as **regelation**.

This experiment may even be performed in warm water.

The same process takes place when a handful of snow is squeezed in making a snowball. The outer layer becomes a shell of ice. Again, wheel-ruts over snow are coated with ice: the snow is liquefied as the wheels pass over it,

and the water thus formed freezes when the pressure is removed. The same process occurs in skating. It has been supposed that the water produced by the melting of the ice acts as a lubricant, for very cold ice is by no means so slippery as ice just below 0°C .

The following experiment illustrates the same process:—

Exp. 69. Perform Bottomley's experiment (a cold room is necessary). Rest a solid block of ice, about as big and of the same shape as a grocer's block of common salt, on two supports and pass a loop of wire round the block between the supports, attach a heavy weight, 10 kilos, to the loop underneath. The wire gradually cuts its way through the ice, leaving, however, the block quite solid.

Immediately beneath the wire pressure liquefies the ice; the water thus formed makes its way to a position just above the wire and freezes there.

It is to be noticed that since the ice melting beneath the wire absorbs heat on melting and the water above gives out heat in freezing, the process is helped by having a wire which conducts heat easily; the heat liberated above is then conducted through the wire to assist in melting the ice below. For instance, it will be found that a copper wire works through more quickly than a steel wire.

Regelation is an important factor in determining the flow of glaciers. At all points where large stresses are set up in the glacier the ice melts, and freezes again as the stress is relieved. In this way stresses in the mass of the glacier are relieved as they arise and the motion of the glacier is facilitated.

Bunsen studied the effect of change of pressure on the melting points of many substances, such as wax and sulphur, which expand on melting. He used tubes as shown in Fig. 84. The main body of the tube is full of mercury. A little of the substance is placed at E in the short limb, and the long limb, A B, which is sealed at the top, contains air and serves as a pressure gauge. The tube was lowered into water and the water gradually heated. The mercury expanded and exerted great pressure on the substance. When the substance melted

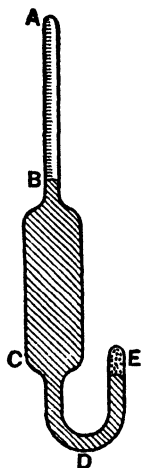

Fig. 84.

the temperature of the water and the pressure in A B were read.

He found that the melting point of paraffin wax was raised from 46.3°C . to 49.9°C . by an application of a pressure of 100 atmospheres.

115. Latent heat of fusion.

Exp. 70. Melt some crystals of sodium thiosulphate—the “hypo” of the photographer—in a flask. Carefully cork the flask and stand it on one side to cool. The melting point is 45°C ., but, if not shaken, it may be cooled to the ordinary atmospheric temperature without solidifying. Now gently remove the cork and drop in a small crystal of the salt. Crystallisation rapidly occurs throughout the mass, and as the mass crystallises the heat rendered latent during the melting of the original crystals reappears as molecular motion and the mass becomes warm to the touch, the temperature rising to the normal melting point (45°C .).

Exp. 71. Cool some water in a test tube by surrounding it by a freezing mixture (Art. 118). If a thermometer is placed in the water it will be found that the temperature falls rapidly at first and afterwards more and more slowly and passes 0°C ., until finally, if the freezing mixture is effective, a quantity of ice suddenly forms and at the same time a sudden rise of temperature to 0°C . takes place.

The explanation of this is that the water is at first cooled *below* the temperature at which freezing should take place, then, suddenly, freezing takes place, and the heat evolved during the process produces the observed rise of temperature.

It has already been noted (Art. 106) that when a substance undergoes liquefaction, or fusion, it absorbs heat, without rise of temperature, during the process. Also (Exp. 70) when a substance undergoes solidification it gives out heat, without fall of temperature, during the process. The heat thus absorbed or evolved, at constant temperature, during fusion or solidification is called the **latent heat of fusion**. A given substance absorbs, per unit mass, during fusion, and evolves, per unit mass, during solidification, a definite quantity of heat which is constant for the same substance under the same conditions.

The latent heat of fusion for any substance may therefore be defined as the quantity of heat required to convert *unit mass of the substance* from the solid state at the melting point to the liquid state at the same temperature. Thus the latent heat of fusion of ice at 0°C . is the quantity of heat required to convert unit mass of ice at 0°C . into water at 0°C . It is also the quantity of heat given out by unit mass of water at 0°C . in becoming unit mass of ice at 0°C . The latent heat of fusion of ice is often called the *latent heat of water*. The heat was supposed to become "latent" in the water during fusion. If the *gramme* is taken as the unit of mass, then the latent heat should be expressed in calories per gramme.

Hence if L denote the latent heat of fusion of any substance then the quantity of heat absorbed during the fusion, or evolved during the solidification, of m grammes of the substance is mL calories.

Exp. 72. Make a rough determination of the latent heat of the fusion of ice.

Light a Bunsen burner; keep it burning steadily during the experiment. Place a tripod over it and put about a pound of fairly dry ice, pieces about the size of a walnut, into a tin can, also a thermometer (though this is not necessary). Quickly place the can over the flame. Stir gently with the thermometer and note the times

- (1) When the can was placed on the flame.
- (2) When all the ice has melted (*i.e.* all is water at 0°C .).
- (3) When the water commences to boil (*i.e.* when the temperature has just reached 100°C .).

Find the differences in times between (1) and (2), (2) and (3), and note that they are roughly as 4 : 5. Now heat has been flowing into the can at nearly a constant rate, and, seeing that 100 calories are needed to raise 1 gm. of ice-cold water to boiling, the latent heat of ice is roughly $\frac{4}{5}$ of 100, *i.e.* 80 calories per gm.

116. Determination of latent heat of fusion of ice.
Principle of the Method. A quantity of dry ice at 0°C . is placed in a weighed quantity of water warm enough to melt all the ice. The temperature of the water is taken before the ice is put in and also after the ice is melted, finally the weight of ice is found. From these data the latent heat of fusion of ice may be calculated.

Let M , m , m_1 denote the masses of ice, water, and calorimeter; t and θ the initial and final temperatures of the water; L the latent heat of ice; and s the specific heat of the calorimeter. Then

$$\begin{aligned} \text{Heat given out by water and calorimeter} \\ = (m + m_1 s) (t - \theta). \end{aligned}$$

Heat absorbed by ice during change of state = $M L$.

Heat absorbed by the melted ice in rising from 0°C. to $\theta^\circ \text{C.}$ = $M\theta$.

Therefore, equating heat absorbed to heat given out, we have

$$ML + M\theta = (m + m_1 s) (t - \theta),$$

from which L can be calculated.

As the experiment lasts some time the cooling correction is of importance, but in this case it may be made practically negligible by adding pieces of ice until a final temperature is reached as much below the air temperature as the original temperature is above the air temperature. Care, however, should be taken that the temperature is not lowered to such an extent that dew is deposited on the outside of the calorimeter.

Exp. 73. Take a calorimeter and shield as in Fig. 76, weigh the calorimeter, two-thirds fill it with warm water at about 30°C. , and reweigh. Place the calorimeter in position and accurately read its temperature. Crack up some clear ice to nutmeg size, and after drying each piece carefully with blotting-paper drop it into the water. The water becomes colder. Stir well with thermometer. Stop the addition of ice when the temperature is down to about 10°C. or 15°C. , and when all the ice has melted stir well, take the temperature, and then take out the thermometer, removing with it as little water as possible. Finally weigh: the difference in the two last weighings gives the mass of ice put into the water. Calculate the latent heat of ice.

Example. Calculate the latent heat of fusion of ice from the following observations:—

Calorimeter weighed 52.94 gm., calorimeter and water weighed 189.45 gm., calorimeter and water and ice weighed 215.88 gm.

Initial temperature = 31.0° C. Final temperature = 13.8° C.

Air temperature = 22° C. Specific heat of metal calorimeter = .095.

Heat absorbed by 26.43 gm. of ice in melting = 26.43 L calories.

Heat absorbed by 26.43 gm. of melted ice in rising from 0° C. to 13.8° C. = 26.43 × 13.8 calories.

Heat given out by water and calorimeter in cooling from 31° C. to 13.8° C. = (136.51 + 5.03) × 17.2 calories.

Therefore 26.43 L + 26.43 × 13.8 = (136.51 + 5.03) × 17.2

$$\text{or } L = \frac{141.54 \times 17.2}{26.43} - 13.8 = 78 \text{ units.}$$

Note that in this experiment the cooling correction was automatically made negligible.

The latent heat of any other substance could be found in a similar way, *e.g.* by putting some of the solid into some of the liquid or some other hot liquid and noting the fall in temperature. In this case the specific heats of the substance in the solid and liquid states would be required, as well as the specific heat of any other liquid used.

TABLE OF LATENT HEATS OF FUSION.

Ice	79.8	Silver	21
Nitrate of sodium	63	Tin	14
Nitrate of potassium (nitre) 47		Sulphur	9.4
Paraffin wax	35	Lead	5.5
Zinc	28	Mercury	3

117. The latent heat of fusion of ice at 0° C. is almost exactly 80 units. This value is a comparatively large one, and it is well that it is so. If the latent heat of fusion of ice were small ice and snow on the earth's surface would melt very rapidly with rise of temperature, and disastrous floods would result. In the same way the height of the snow-line would increase, the distribution of glaciers would change, and portions of the earth's surface now covered with snow or ice all the year round would be cleared during a portion of the year. Further, if the latent heat of ice were small our ponds and lakes would freeze very much sooner, and perhaps quickly freeze solid. While this would make more skating available it would be destructive of fish and other life in the ponds and lakes.

118. Solution. When a solid is dissolved in a liquid we have, in general, three distinct effects possible:—

- (a) The physical change of state of the solid.
- (b) Chemical combination.
- (c) Dissociation.

In solution, properly so called, only (a) takes place, and the process is therefore always accompanied by a fall of temperature due to the absorption of the latent heat of fusion from the solution. For example, the solution of sodium sulphate or ammonium nitrate in water lowers the temperature of the solution by about 15°C ., and for this reason these solutions are often used as freezing mixtures.

In the majority of cases, however, chemical action takes place as well as simple solution, and we then have two thermal effects corresponding to (a) and (b) above. The changes referred to in (a) and (c) are always accompanied by absorption of heat, and that of (b) always *produces* heat, and thus the final effect depends on whether the absorption of heat due to (a) and (c) is greater, equal to, or less than the evolution of heat due to (b).

Exp. 74. (1) Mix 4 parts by weight of sulphuric acid with 1 part of snow. A rise of temperature of nearly 90°C . is produced. (2) Now mix 1 part of sulphuric acid at 0°C . with 4 parts of snow. The temperature falls nearly 20°C .

A **freezing mixture** is one in which a low temperature is produced by the absorption of heat resulting from the change of state of some constituent of the mixture. It must be understood that the low temperature of the mixture is only temporary; it is produced *during* the change of state in the mixture, and is complete when that is complete.

The simplest freezing mixtures are those referred to above, where the fall in temperature results from simple solution and the partial dissociation that often accompanies it. A common mixture for laboratory purposes is salt and ice, or salt and snow. In this mixture both constituents change state, and the temperature resulting from this double absorption of heat is -22°C ., which is the freezing point of a definite compound of salt and water.

Exp. 75. (1) Dissolve sodium sulphate or phosphate or ammonium nitrate in water. Note the depression of the temperature. (2) Mix 4 parts of crystallised chloride of calcium with 3 parts of snow or ice. What is the lowest temperature you can get?

119. Depression of the freezing point of salt solutions.—The freezing point of a salt solution is lower than that of pure water. It is of interest to find out how the depression of the freezing point depends on the concentration. In carrying out the experiments use is made of the fact discovered in Exps. 70, 71, that a solution may be cooled some degrees below its normal freezing point before solidification occurs, and then suddenly freezing occurs and the temperature rises to its normal freezing point, where it remains for some time until gradual cooling again sets in.

Exp. 76. Find how the depression of the freezing point of a solution of common salt in water depends on the concentration.

Fit a boiling tube, B (Fig. 85), with a cork. Bore two holes through the cork, a central one to hold firmly an accurate thermometer, T, and a small side hole to admit a wire stirrer, S. The thermometer should read to $\frac{1}{10}^{\circ}$ C., and the scale should extend 10 degrees or so below zero.

Measure out 50 gm (= 50 c.c.) of distilled water by a burette or pipette, and put it into the tube B.

Make a freezing mixture of ice and salt in a stout jar, J, place the tube well in the mixture, stir well. Solidification gradually occurs, and as the ice crystals accumulate the temperature remains steady. Note this temperature: it is the temperature of the freezing point of pure water,

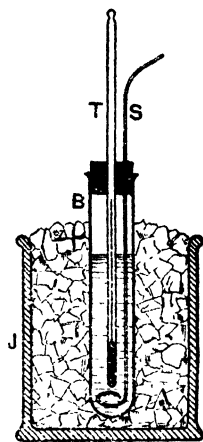

Fig. 85.

Withdraw the tube and melt the ice. Weigh out carefully about 2 gm. of common salt. Dissolve this in the water, replace the tube in the freezing mixture and stir very gently. The temperature gradually falls, passes

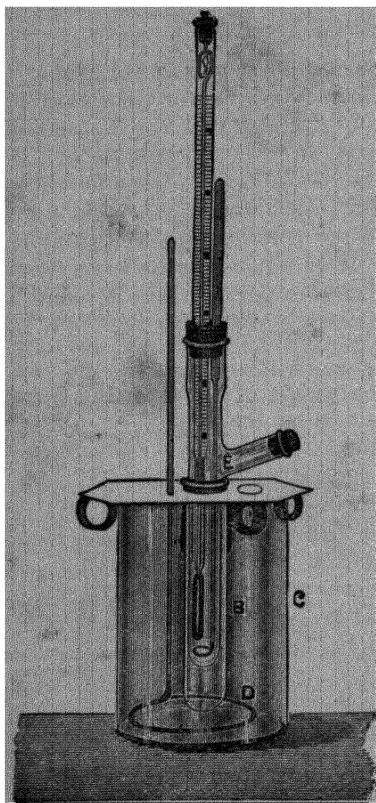

Fig. 86.

the freezing point of pure water, is then arrested and quickly rises to a temperature just below the normal freezing point. Here it remains steady for some time while solidification occurs. Carefully read the thermometer. This gives the temperature at which pure ice separates out in the given solution.

The solution then becomes more concentrated, and if the tube is allowed to remain in the freezing mixture the temperature continues to fall as the freezing of this solution proceeds. This, however, is not what we want to study in this experiment.

Withdraw the tube, melt the contents, add another 2 gm. of salt, and again determine the freezing point. Repeat until about 12 gm. of salt have been added.

Calculate the depression of the freezing point for the different quantities of salt, and plot a curve between depression of freezing point and mass of salt per 100 gm. of water. It will be a straight line, showing that for weak solutions the depression is proportional to the concentration. Calculate from the curve the depression of the

freezing point for a 1 per cent. solution (*i.e.* 1 gm. of salt dissolved in 100 gm. water). It is just under 6°C .

The experiment just described is used largely in physical chemistry for the determination of molecular weights, for Raoult found that the depression of the freezing point was inversely proportional to the molecular weight of the dissolved substance. The more accurate apparatus shown in Fig. 86, which is due to Beckmann, is used, but the details are the same. Reference may be made to text-books of physical chemistry for the theory of the depression of the freezing point and the calculations whereby the molecular weight of the solute is determined.

120. Specific heat determined from the latent heat of fusion of ice. Ice calorimeters. We have seen that when unit mass of ice at 0°C . is melted to water at 0°C . 80 thermal units are absorbed. If, then, we find out how much ice a known mass of any substance at an initial known temperature is able to melt, we can easily calculate how many thermal units it evolves in falling from its original temperature to the temperature of the ice, and from this we easily get the quantity of heat given out by unit mass falling one degree, that is, the specific heat of the substance. There are several methods of applying this principle, but the formula to be applied in each case is the same.

Let M = mass of the body, S = its specific heat. It is heated to a temperature $T^{\circ}\text{C}$. and then dropped into an ice chamber. In falling to 0°C . it melts, say, a mass m of ice.

The heat given out by the hot body = MST units.

The heat absorbed by the ice in melting = mL units,

$$\therefore MST = mL;$$

$$\therefore S = \frac{mL}{MT}.$$

Hence, in order to calculate the heat absorbed in an ice calorimeter it is necessary to determine with some exactness the mass of ice melted. This may be attempted by two methods: (a) by direct weighing of the water pro-

duced by the melting of the ice, and (b) by measuring the decrease in volume resulting from the change of a portion of the ice into water. In the second method use has to be made of the fact that the volume of 1 gm. of ice at 0°C . is 1.0906 c.c., and the volume of 1 gm. of water at 0°C . is 1.0001 c.c., so that 1 gm. of ice at 0°C . in melting to become water at 0°C . decreases in volume by .0905 c.c., that is, by about one-twelfth of its volume, or one-eleventh of the volume of the water.

Exp. 77. Find the density of Ice. Make a mixture of methylated spirits and water of such density that a piece of ice remains submerged in it at any point at which it is placed. The densities of the solution and ice are thus the same. Quickly withdraw the ice and then determine the density of the solution at 0°C . with a specific gravity bottle or pynknometer. From the density calculate the volume of 1 gm. of ice and the decrease of volume when 1 gm. of ice melts.

121. Black's ice calorimeter.

Exp. 78. Make and use a Black's ice calorimeter. Take a nearly cubical block of ice (A, Fig. 87) about 4 inches edge, and drill a hole about an inch in diameter and an inch deep in it. Make the bottom smooth and slightly conical. Fit over the hole, as a cover, another block of ice, B, about 2 inches thick, as shown in Fig. 87.

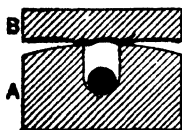

Fig. 87.

Dry the cavity in the block thoroughly with filter paper. [If the cover fits the top of the hole well no heat can reach the cavity from the surroundings of the block. The block may melt on the outside, but there is no melting or freezing in the interior unless heat is given out or absorbed by a body placed in the cavity.] Then heat about 50 gm. of, say, brass to 100°C ., and drop it into the cavity. Replace the cover and allow the whole to stand until

the brass has time to cool to 0°C . The water produced by the melting of the ice collects in the cavity and remains there *unchanged in quantity* so long as the block is intact. (The top of A is slightly rounded so that no surplus water may trickle down the hole.) Collect this water by means of a weighed sponge or a small pipette and a piece of filter paper, and determine its mass. Calculate the specific heat of brass from your observation.

Example. Find the specific heat of brass from the following observations:—A lump of brass of mass 50 gm. was heated to 100°C . and dropped into the hollow of a Black's ice calorimeter. The water produced weighed 5.9 gm. Arguing as above we get—

$$50 \times S \times 100 = 5.9 \times 80 = 472,$$

$$\therefore S = .094.$$

122. Bunsen's ice calorimeter. The action of this calorimeter depends upon the fact that ice contracts on melting. When 1 gramme of ice melts to 1 gramme of water, the diminution in volume amounts to .0905 c.cm., and 80 calories of heat are absorbed.

The calorimeter (Fig. 88) consists of a glass vessel, A, having a thin glass tube, B, fused into it as shown in the figure. At its lower end A passes into the tube C D, which is bent up as shown in the figure, and at D is fitted with a cork carrying a bent piece of capillary tubing, T T. The horizontal part of this tube is carefully calibrated and carries a graduated scale so that the volume between any two divisions is accurately known.

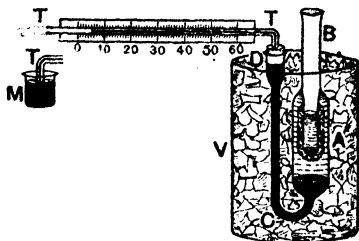

Fig. 88.

To prepare this apparatus for use the upper part of A must be filled with pure, *air-free* distilled water, and the lower part and the communicating tube with pure mercury. The instrument is then placed in a suitable vessel, V, and *surrounded as completely as possible with pure snow or melting ice*. A current of alcohol which has been cooled by a freezing mixture of salt and ice is then passed through the tube B until a shell of ice is formed round it in the water in A. B is now cleaned out, a layer of glass, wool, or sand is placed in its bottom, and a small quantity of distilled water added. The instrument is left, preferably over night, until everything arrives at 0°C . and the position at the end of the mercury column in the tube T becomes stationary. Its position is then read.

A known mass of the substance the specific heat of which is required is raised to a known temperature in a suitable heater, and then dropped into the water in B. The heat given out by this substance as it cools to 0° C. melts a quantity of ice in A; a consequent diminution of volume is produced, and is indicated by a motion of the end of the mercury column in T towards the calorimeter. When the position of this column becomes stationary a second reading is made, and the difference of the two readings thus taken on T determines the decrease in volume caused by the melting of ice in A.

Let the decrease of volume thus determined be denoted, in cubic centimetres, by v . Then, since the melting of 1 gramme of ice in A would produce a diminution of volume equal to 0.0905 c.cm., the mass of ice melted in A must equal $\frac{v}{0.0905}$ grammes, and as each gramme of ice requires 80 calories of heat to melt it, the quantity of heat given out by the substance must equal $\frac{80v}{0.0905}$ or $884v$ calories.

But, if M denote the mass of this substance in grammes, T the temperature to which it was raised, and S its specific heat, then the heat it gives out in cooling to 0° C. is equal to MST calories. Thus we have

$$884v = MST;$$

$$\therefore S = \frac{884v}{MT}.$$

This instrument, when once put in working order, may be used to make several determinations and give accurate results, but it is rather troublesome to fill and prepare for use. Observe that in this method there can be no error due to exchange of heat between the instrument and the surroundings.

Bunsen's ice calorimeter has proved very useful in the determination of the specific heats of bodies which can only be obtained in small quantities, *e.g.* the rare metals.

It is evident that, if we work with a substance of known specific heat, we may use this apparatus to determine the latent heat of water or to show that ice contracts on

melting, and, by measuring the contraction, to determine the density of ice. Bunsen made both these determinations in 1870, and found 80.02 as the latent heat of fusion of ice on the Centigrade scale and 0.9167 gm. per c.c. as the density of ice at 0° C.

The mean results of later experimenters for these two quantities are 79.8 and .9169.

If we let the free end of the tube T dip into some mercury, M (Fig. 88), contained in a small beaker, we may calculate the decrease of volume when the ice melts from the decrease of weight of the mercury in this beaker. The tube T must be kept full of mercury. In this case no scale is required to T.

Exp. 79. *Set up a simple form of Bunsen's calorimeter and use it to find the sp. ht. of brass.* Take a wide-mouthed 4-oz. bottle, B (Fig. 89), and fit it, as shown in figure, with a rubber stopper carrying a test-tube, T, and a piece of tubing, t, of narrow bore ($\frac{1}{8}$ mm.). Fill the bottle with a large number of small pieces of air-free ice and water and insert the stopper so that all air is excluded. Drop a little clean silver sand into the test-tube, T, and two-thirds fill it with water. Let now the bottle be placed in a larger vessel, V, and completely surrounded with ice, as shown in the figure, so as to protect it from external heating. When the level of the water in t becomes stationary, at a, say, the apparatus is ready for use.

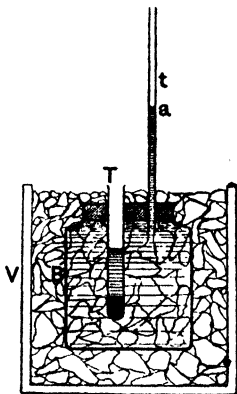

Fig. 89.

Drop the brass straight from the heater into the test-tube, where it is received on the sand without damage to the tube. The heat given out by the brass melts some ice in the bottle and causes a fall in the level of the water in t. Observe the length of this fall and from the known cross section of the bore of the tube calculate the decrease in volume attending the melting of the ice. From this the

quantity of heat given out by the substance can be calculated, and thus the specific heat of the substance can be determined.

Example. Find the specific heat of brass from the following observations:—5 gm. of brass at 100°C . was dropped into the test-tube of above apparatus and the observed fall of level in the indicating tube was 54 mm. The cross section of the bore of the tube was $\cdot 010$ sq. cm.

The decrease in volume due to melting of the ice is $5\cdot 4 \times \cdot 01$ c.c. = $\cdot 054$ c.c.

The melting of 1 gm. of ice causes a decrease in volume of $\cdot 091$ c.c. Hence a decrease of $\cdot 054$ c.c. indicates the melting of $\cdot 054$ gm. or $\cdot 59$ gm. nearly. The quantity of heat given out by this ice in melting is $\cdot 59 \times 80$ or 47 calories. We therefore have, if S denotes the specific heat of brass,

$$5 \times 100 \times S = 47$$

$$\text{or } S = \cdot 094.$$

123. The specific heat of ice. To find the specific heat of ice it is, of course, necessary to work with ice below 0°C .

Exp. 80. Find the specific heat of ice.

(1) **Person's method.** Place 20 gm. of pure water in a thin copper flask, immerse a delicate thermometer in it, and keep it in a freezing mixture for some time until the temperature is just below -10°C . Arrange matters so that the temperature shall slowly rise to -10°C . In the meantime take a copper calorimeter of the ordinary form, put in it a certain quantity of water, provide it with a delicate thermometer and stirrer, and then put a cover on to prevent evaporation. Heat this water to a temperature about 25°C ., stir well and let it cool to 20°C .

Suppose now you have got the ice to -10°C . Place the ice flask within the water calorimeter and watch the readings of the two thermometers. The temperature of the ice will rise, that of the water will fall. If a large quantity of warm water be used the final temperature of both flask and calorimeter and contents may be above 0°C . If a large quantity of ice is used the final temperature may be below 0°C . If intermediate quantities are employed the final temperature may be 0°C . with some of the ice melted, or with some of the water in the calorimeter frozen.

Since it is rather hard to find exactly how much ice has melted it is best to arrange that the final temperature be above zero. In this case, if M gm. of hot water at T° are employed, and the

final temperature is t° , and the water equivalents of the copper flask and calorimeter are m_1 and m_2 respectively, then

$$(M + m_2)(T - t) = 20(10s + L + t) + m_1(10 + t)$$

from which if either L or s be known the other may be found.

(2) Another method often adopted is to watch the two thermometers as they change and take readings of both at the same time: thus if M gm. of water at $T^\circ\text{C}$. are employed in the calorimeter and readings were taken when the temperature of this had fallen to $t^\circ\text{C}$. and the temperature of the ice had risen to $-p^\circ\text{C}$., then we have

$$(M + m_2)(T - t) = (20 \times s + m_1)(10 - p)$$

from which s can be found. Of course this method can be used in conjunction with the above method.

Likely sources of error are

(1) Cooling of water by evaporation. The actual loss of water by evaporation is negligible, but the heat it removes latent is much more considerable.

(2) Radiation losses from the calorimeter. This may be lessened by using the ordinary devices employed in calorimetry.

(3) The temperature of the ice at the start may not be uniformly -10°C . Also if the second method is used it is not likely that the temperature of the ice will be uniformly at $-p^\circ\text{C}$.; the temperature will no doubt decrease towards the middle of the ice. This error cannot be easily allowed for except by making the processes very slow.

The mean value of the specific heat of ice for the range -50°C . to 0°C . is $\cdot 47$. It decreases as the temperature is lowered.

124. Nature of latent heat. When a piece of ice at 0°C . is heated its temperature does not rise until all the ice has melted. What has become of the heat given to the ice?

Think of a cannon-ball lying on the ground: it is at rest, and has no destructive power. Think of it now flying through the air at 1,000 ft. a second. It has an immense store of *energy because it is in motion*. Again, think of the ball on the very brink of a precipice, so exactly poised that the least conceivable force would dislodge it and enable it to fall. Again it has a store of energy, but this time *because it is in a particular position*—a position of advantage with regard to the force of gravity, which is ready at any moment to pull it to the ground. The energy is not active at the moment under consideration, but it may become active at any moment. It may be called *potential*, latent, stored energy, or energy of position, to distinguish

it from that of the moving ball, which may be called *kinetic* or active or energy of motion.

Now return to the melted ice, and remember that the effect of absorbed heat upon a body is usually twofold. It increases the vibratory motion of its molecules, or, in other words, raises its temperature or increases its molecular *kinetic* energy. But it also drives the molecules further asunder into strained positions, from which they will spontaneously return when the temperature falls. This increases the molecular *potential* energy of the body. In the melting of the ice none of the absorbed heat increases the kinetic energy: it is wholly devoted instead to forcing the molecules into new positions—positions of advantage with respect to some intermolecular force, which will drive them back again when the absorbed heat is again lost and the water again becomes solid.

We do not know enough about the molecular constitution of water to be able to define those forced changes of position or the force which resists them. It is not simply repulsion in opposition to cohesion; for the ice contracts in melting. It will suffice if we understand that what takes place during the melting is the conversion of the kinetic energy of the absorbed heat into potential energy, and it will enable us to attach a tolerably definite meaning to the term **latent heat**, which is applied to the energy as stored up in the molecules of the liquid water.

When the water again freezes, and the molecules return to their former interrelations, all this latent heat again becomes sensible or kinetic as vibratory motion, and so from the moment the water begins to freeze, until the last drop is frozen, no fall of temperature takes place.

EXERCISES IX.

(In working out calculations take the latent heat of fusion of ice as 80.)

1. Determine the melting point of white wax, stearic acid (stearin candles), urea, tartaric acid, naphthalene (moth balls), etc. (Check by a book of tables.)

2. Taking the specific heat of lead as 0.031 and its latent heat as 5.07, find the amount of heat necessary to raise 15 gm. of lead from a temperature of 115° C. to its melting point, 320° C., and to melt it.

3. The melting point of paraffin wax was determined by a method of cooling. The following readings were taken every half minute. Plot a curve and find the melting point.

55.8°, 54.8°, 54°, 53.5°, 53.05°, 52.85°, 52.55°, 52.5°, 52.5°, 52.5°, 52.5°, 52.45°, 52.25°, 52.1°, 52.0°, 51.9°, 51.7°, 51.6°.

4. Why do people sprinkle salt on pavements when these are coated with ice?

5. Ten gm. of ice at - 10° C. are mixed with 120 gm. of water at 80° C. Find the final temperature. (Specific heat of ice = 0.5.)

6. Determine the latent heat of ice from the following data :—

Weight of brass calorimeter (sp. heat .09)	35 gm.
" " " " " + water	156 gm.
Initial temperature of water and calorimeter	24° C.
Final " " " " " "	...	17° C.
Weight of calorimeter, etc., after addition of ice	165 gm.
The ice was originally at 0° C.		

7. 500 c.c. of mercury at 56° C. are put into a hollow in a block of ice, and it is found that 159 gm. of ice are liquefied; find the specific heat of mercury.

8. How many units of heat would cause a mixture of ice and water to contract by 50 c.mm., if 100 c.c. of water at 0° C. become 109 c.c. on freezing?

9. A gm. of ice at 0° C. contracts 0.091 c.cm. in becoming water at 0° C. A piece of metal weighing 10 gm. is heated to 50° C. and then dropped into a Bunsen's calorimeter. The total contraction is .063 c.c. Find the specific heat of the metal.

10. Ten gm. of water at 96° C. are placed in the inner tube of a Bunsen's calorimeter, and it is found that the volume of the contents of the outer portion decreases by 1.09 c.c. Find the specific gravity of ice?

11. If 100 c.c. of water in freezing become 109 c.c. of ice, and the introduction of 20 gm. of mercury at 100° C. into a Bunsen's calorimeter causes the end of the column of mercury to move through 74 mm. in a tube 1 sq. mm. in section, find the spec. heat of mercury.

12. Three separate mixtures are made, namely—(1) Water and snow, (2) water and salt, (3) snow and salt. If all the materials were, before being mixed, at 0° C., which mixture will be at the highest temperature and which at the lowest? and why?

EXAMINATION QUESTIONS ON CALORIMETRY AND THE LOWER CHANGE OF STATE.

(Take the latent heat of ice as .80 unless specified otherwise, and the density of mercury as 13.6 gm. per c.c.)

1. A calorimeter of water-equivalent 12 gm. contains 100 gm. of water at 12° C. When 100 gm. of a metal at 100° C. are added, the resulting temperature of the mixture is 20° C. Find the specific heat of the metal.

2. A copper vessel contains 100 gm. of water at 12° C. When 56 gm. of water at 30° C. are added, the resulting temperature of the mixture is 18° C. What is the water-equivalent of the vessel?

3. A mass of 200 gm. of copper, whose specific heat is .095, is heated to 100° C. and placed in 100 gm. of alcohol at 8° C., contained in a copper calorimeter whose mass is 25 gm., and the temperature rises to 28.5° C. Find the specific heat of alcohol.

4. Explain carefully one method of finding the specific heat of a liquid, pointing out the sources of error and the precautions necessary to obtain an accurate result.

5. Describe some one method of measuring a very high temperature, say one somewhere about 1000° C.

6. Define *specific heat*, and explain what is meant by saying that the specific heat of a substance is variable.

(a) Account for the fact that when 48 gm. of a particular liquid at 20° C. are mixed with 45 gm. of the same liquid at 100° C., the resulting temperature is about 60° C. (b) Would the resulting temperature be as above if the liquid were water?

7. Given milk at 95° C. and water at 15° C., how much of each would you take, assuming their specific heats to be equal, to obtain a mixture at 40° C. weighing 80 gm.?

Would the final temperature be less if the milk and water were allowed to stand for 10 minutes in a room at 15° C. before mixing than if they were mixed first and then allowed to stand for the same time?

8. A volume of air that would measure 12 litres at normal temperature and pressure is contained in a gasometer. It is then slowly driven through, first, a copper coil heated by a steam bath to 100° C., and then through a thin copper coil in a copper calorimeter containing 300 gm. of water. The calorimeter and its contained coil weigh 200 gm. During the process the temperature of the water in the calorimeter is observed to rise from 16° to 17° C. Determine from these data and from the following constants the specific heat of air. [Sp. ht. of copper = 0.1; 1 litre of air at normal temperature and pressure weighs 1.294 gm.]

9. How do you account for the leakage from water pipes on a thaw after a severe frost?

It is a common practice to leave water taps slightly turned on during a frost to prevent freezing. How do you suppose the freezing is prevented?

10. How can you prove experimentally that heat is absorbed when a solid melts? Describe a method for measuring how much heat is absorbed during the melting of a pound of wax.

11. 100 gm. of iron (sp. ht. .112) at 50°C . are placed in a vessel containing 1,000 gm. of water at 0°C . ; how many gm. of ice at 0°C . must be added to reduce the temperature of the mixture to 0°C . ? All the ice is supposed to be melted.

12. What is meant by the specific heat of a substance? Eight gm. of ice at 0°C . are dropped into 64 gm. of paraffin oil at 20°C . and are just melted in cooling the oil to 0°C . What is the specific heat of the oil?

13. The temperature of a pond is 8°C . when a freezing wind sets in. Describe what happens as the water parts with its heat, and, assuming that it parts with it at a uniform rate, compare the time taken to the beginning of freezing with the time taken to freeze the top half-inch of water, the total depth being 20 in. (Assume that the bottom layer of water falls to 4°C . and remains at this temperature, and that finally the temperature gradient is uniform from the bottom of the pond to the surface of the water.)

14. Describe and explain the action of a Bunsen calorimeter, whereby quantities of heat are measured by the amount of ice melted by them. Twenty-five gm. of water at 15°C . are placed in the inner tube of the calorimeter, and it is found that 6.8 gm. of mercury are drawn into the capillary tube. Determine the density of ice.

15. One gramme of metal heated to 100°C . is dropped into a Bunsen ice calorimeter in which the weight of mercury needed to fill one centimetre of the index-tube has been found to be .026 gm. The thread of mercury moves through 52.5 mm. What is the mean specific heat of the metal? One gm. of water in freezing expands .0907 c.c. and its latent heat of fusion is 80.02. Would you prefer in practice to find the constant of the instrument in any other way?

16. Forty-five grammes of water at 20°C . are mixed with 20 gm. of ice at -10°C ., and, in consequence, half of the ice is melted. The latent heat of fusion being 80 units, find the specific heat of ice.

Describe how you would perform an experiment to test the accuracy of the above numbers, assuming the latent heat of fusion to be correct, and point out the most likely sources of possible error in your experiment.

CHAPTER X.

PROPERTIES OF VAPOUR.

125. Change of state from liquid to vapour. When water is boiled steam is given off, rises in the air, and disappears. It is evidently distributed through the surrounding air as an invisible gas. Again, if a bottle of volatile liquid such as ether, methylated spirits, or turpentine is exposed to the air, our sense of smell informs us that the substance is diffused in a gaseous state through the air. The process by which substances in the liquid form enter the gaseous state is called *evaporation* or *vaporisation*. It takes place at all temperatures, the only effect of temperature being that of altering the rate at which the process is carried on. Thus, if a saucer of water is placed out of doors, the water will disappear faster on a dry summer day than on a dry winter day.

126. Vapour pressure. A liquid gives off vapour from its free surface into the adjacent atmosphere *at all temperatures*. Also this vapour is gaseous in character, and may be expected to exert pressure in the same way as a gas does. It is therefore desirable to submit the behaviour of a vapour in this respect to the test of experiment.

Exp. 81. Take a perfectly clean and dry barometer tube about 85 cm. long and from 5 mm. to 1 cm. in diameter and set up a simple barometer with clean, dry, warm mercury. Note carefully the height of the mercury column when cold by means of a metre scale and compare it with that of a standard barometer. If the reading is more than a mm. below the reading of the standard, the barometer is not satisfactory, and another trial must be made. Now introduce a *very small* quantity of water into the Torricellian

vacuum* of the barometer and note the result. The water may be introduced by passing up a very small piece of filter paper soaked in water into the vacuum.

It will be found that the water vaporises in the vacuum almost instantly and that the column of mercury is slightly depressed. For example, the height of the column might be reduced from 758 mm. to 752 mm., the pressure of the vapour thus causing a depression of 6 mm. This evidently indicates that the vapour exerts a pressure which is measured by the depression of the mercury column. Thus, in the example given the pressure of the vapour plus the pressure due to 752 mm. of mercury is equal to a pressure of 758 mm. of mercury, and the pressure of the vapour is therefore equal to that due to 6 mm. of mercury.

Now introduce another very small quantity of water into the barometer tube and again note the result. It will be found that again the water vaporises, but not so quickly as at first, and the column of mercury is again depressed. For example, the height of the column may now fall from 752 mm. to 748 mm., thus showing a further depression of 4 mm.

This indicates that as the quantity of vapour in the enclosed space increases the pressure also increases. In the case of the example given the pressure of the vapour increases from 6 mm. to 10 mm. of mercury.

Repeat the operation of passing a very small quantity of water into the tube several times and note the results.

It will be found that the additional quantities of water vaporise more and more slowly, causing in each case a slight but decreasing depression of the mercury column, until finally the water ceases to vaporise altogether and remains as a thin film on the surface of the mercury, and there is no further depression of the mercury column. This shows that when the space is *saturated* with vapour the pressure of the vapour attains a final value, which is the *maximum vapour pressure* under the existing conditions.

* This space is not a perfect vacuum, as it contains a very small quantity of mercury vapour derived by evaporation from the liquid mercury. The vapour pressure of mercury is, however, negligible at ordinary temperature. See Art. 130.

This method of measuring vapour pressure is due to Watt of steam-engine fame.

Exp. 82. Repeat the above experiment, using a barometer tube with a large bulb at the closed end. It will be found that a larger quantity of vapour is necessary to saturate the larger space available, but that the maximum vapour pressure is exactly the same if the temperature is the same.

Exp. 83. Repeat **Exp. 81** with alcohol and ether, using a clean tube and clean, dry mercury in each case. It will be found that, at the same temperature, the maximum vapour pressure for alcohol is greater than for water and greater for ether than for alcohol. For example, at 20°C . the maximum vapour pressure for water would be about 17 mm., for alcohol about 60 mm., and for ether about 400 mm. of mercury.

Exp. 84. Repeat **Exp. 81** with one of the above liquids, say alcohol, at two different temperatures—for example, in a cold room at 10°C . and in a warm room at 20°C . The maximum vapour pressure will be found to be greater at the higher temperature.

This apparently indicates that the maximum vapour pressure for any substance increases with the temperature.

The experiments described above establish the following facts. A liquid gives off vapour from its free surface at all temperatures, and this vapour behaves like a gas and exerts pressure. Also, when sufficient liquid is present to saturate a closed space with its vapour, the pressure of the vapour attains a maximum value, which is constant for a given liquid at a given temperature, but apparently increases as the temperature rises.

127. Variation of maximum vapour pressure with temperature. The result of **Exp. 84** indicates that the maximum vapour pressure of a vapour increases with the temperature. It is desirable, therefore, to submit this question of the variation of the maximum vapour pressure with temperature to further experimental investigation.

Exp. 85. Set up two simple barometers A, B, as described in **Exp. 81**, and fit them into a cork in a wide jacket tube, J, as shown in **Fig. 90**. Place a wooden

millimetre scale either between the two tubes or behind them and so arrange that readings can be taken to the nearest millimetre.

Fill the jacket tube with warm water, about 60°C .,* and suspend a thermometer t in the water to indicate the temperature. A stirrer s should also be arranged to keep the water in constant motion, and so secure uniformity of temperature throughout its mass. A serves as an ordinary barometer. Introduce into the vacuum of B a sufficient quantity of the liquid to be vaporised, say water. As the water in the wide tube slowly cools note the depression of the mercury column in B with respect to A , and so determine the maximum vapour pressure of water vapour at a number of different temperatures between 60° and the temperature of the room. Then add ice and take readings down to 0°C .

It will be found in studying the result that the maximum vapour pressure increases as the temperature rises and that for *equal* increments of temperature the corresponding increments of pressure rapidly increase. For example, the following



Fig. 90.

pressure are the

Temperature.	Maximum Vapour Pressure in Mm. of Mercury.
60°C .	140
50°C .	92
40°C .	55
30°C .	31
20°C .	17
10°C .	9
0°C .	5

* A simple method of heating a quantity of water placed in a jacket tube, as shown in Fig. 90, is to take a long U tube, immerse the curved end in the water and pass steam through the tube from a boiler.

Here for equal increments of temperature, each of ten degrees, between 0°C. and 60°C. the corresponding increments in pressure are 4, 8, 14, 24, 37, and 57 mm. of mercury.

No simple law can be given connecting the increase of pressure with the increase of temperature. When, how-

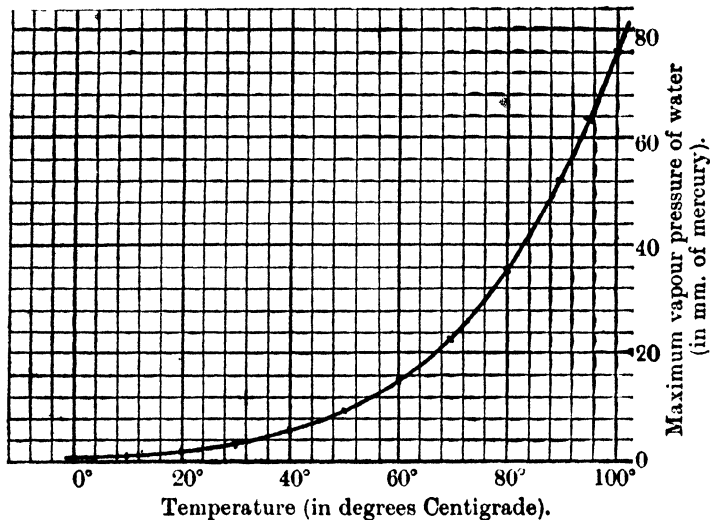

Fig. 91.

ever, the results of experiment are plotted with temperatures as abscissae and pressures as ordinates a smooth curve of the form shown in Fig. 91 is obtained. It is possible to obtain from this curve the pressure at *any* temperature included in the range of the curve.

Exp. 86. Repeat Exp. 85, but begin by carefully filling the outer tube with boiling water. It will be found that the mercury column is depressed almost to the level of the mercury in the cistern, and that the column of vapour is now so long that great difficulty is experienced in maintaining it at a constant temperature. This method of experimenting is therefore not suitable under these conditions. Art. 139 describes a better method.

Exp. 87. Repeat **Exp. 85** with (i) alcohol, (ii) carbon bisulphide instead of water, and measure the maximum pressure of vapour for temperatures between, say, 10°C . and 50°C . The general results will be found to be similar to those obtained for water vapour, the pressures at 10°C ., 20°C ., 30°C ., and 40°C . being respectively 24, 44, 78, 134 mm. of mercury for alcohol, and 200, 300, 435, and 620 mm. of mercury for carbon bisulphide.

We thus see that in all cases the maximum pressure of a vapour increases as the temperature rises, and that *equal* increments of temperature show *increasing* increments of pressure.

128. The work of Dalton, Gay Lussac, and Regnault. Dalton's apparatus is shown in **Fig. 92** and needs little description, C is a cast-iron cistern containing mercury, V V a glass cylinder, and T, T' the barometer tubes. The chief defects of this method were:—

1. The difficulty of securing a uniform temperature throughout the column of water in V V.

2. The difficulty of accurately measuring the difference of level in T and T' through the cylindrical walls of V V.

3. The limited range of the method. At 100°C . the column in T' is depressed to the level of the mercury in C, and hence observations above 100°C . are impossible.

Regnault adopted the general principle of Dalton's method, but he modified the apparatus considerably, and finally adopted three different forms of apparatus for different ranges of temperature. We shall briefly notice these forms.

1. *Apparatus for determinations below 0°C .*

It should here be noticed that aqueous vapour is given off by ice at all temperatures, the pressure being quite appreciable for a considerable range below 0°C . The apparatus employed is shown in **Fig. 93**, and

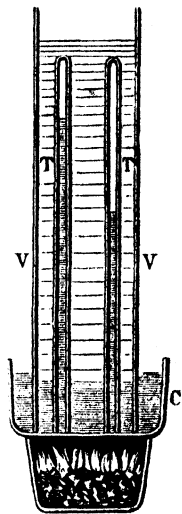

Fig. 92.

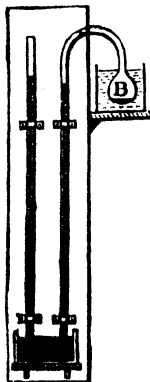

Fig. 93.

taken in connection with what has already been said, its general method of action is obvious.

The bulb B is surrounded by a freezing mixture of calcium chloride and snow, and, as will be shown in Art. 151, the temperature of this mixture is the lowest to which the vapour inside the tube is subjected, the vapour pressure indicated is that which corresponds to this temperature; for equilibrium can exist only when the pressure throughout the space occupied by the vapour is the same, and, as the pressure in B can never be greater than that corresponding to the temperature of the freezing mixture, it follows that this must be the pressure throughout the space. The temperature of the mixture can be altered by varying the proportions of the constituents. This form of apparatus was first used by **Gay Lussac**, and is sometimes referred to under his name.

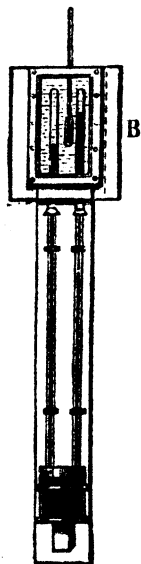

Fig. 94.

2. *Apparatus for determinations between 0° C. and 50° C.* This apparatus (Fig. 94) is a slightly altered form of Dalton's apparatus described above. Between 0° C. and 50° C. the maximum pressure of aqueous vapour is less than 10 cm., hence it is necessary to surround only the upper parts of the tubes with water, as in Exp. 85.

This was done by fitting the tubes into a metal box, B, which was closed in front by a window of plate-glass, through which the measurement of the difference of level in the two tubes could be accurately made. The temperature of the water in B was varied

by means of a spirit lamp adjusted at different distances from the bottom of the box.

3. *Apparatus for determinations above 50° C.* In this apparatus (shown in Fig. 105) a principle different to that adopted in (1) and (2) is employed. Regnault applied the fact that, when a liquid boils, the maximum vapour pressure corresponding to the temperature of ebullition is equal to the external pressure. This question is fully

considered in Art. 139, where the apparatus here referred to is described.

Magnus and Dulong and Arago also made careful determinations of the maximum pressure of aqueous vapour at different temperatures, and obtained results almost identical with those of Regnault.

The following table gives, in a convenient form, a summary of Regnault's results:—

TABLE OF PRESSURE OF AQUEOUS VAPOUR.

[REGNAULT.]

Temperature.	Pressure in Mm. of Mercury at 0° C.	Temperature.	Pressure in Mm. of Mercury at 0° C.
- 10° C.	2·1	70° C.	233·1
- 5° C.	3·1	80° C.	354·6
0° C.	4·6	90° C.	525·5
5° C.	6·5	95° C.	633·8
10° C.	9·2	100° C.	760·0
15° C.	12·7		(= 1 atmos.)
20° C.	17·4	110° C.	1075·4
30° C.	31·5	120° C.	1491·3
40° C.	54·9	150° C.	3581·0
50° C.	92·0		(= 4·7 atmos.)
60° C.	148·8	200° C.	11690
			(= 15·4 atmos.)

139. Dalton's Laws of Vapours. So far we have considered the production of vapour in a vacuum, and in the experiments for the determination of maximum vapour pressure the vapour only was present in the closed space. It is necessary now to inquire if the results obtained need to be modified when vaporisation takes place in a closed space containing air or other gas or vapour with which there is no chemical action.

Exp. 88. Find whether the maximum pressure of a particular vapour, say ether vapour, at a given temperature is the same whether vaporisation take place in the

presence of a gas, such as air, or in a vacuum. For this purpose the apparatus shown in Fig. 95 may be used.

The apparatus is a modification of Boyle's Law apparatus (see Fig. 55). The closed tube V is replaced by the tube AB with two stopcocks S_1 and S_2 . Dry air is first introduced into this tube and its pressure measured in the usual way.

A small quantity of the liquid to be vaporised is then placed in the funnel of the tube and by opening and closing the stopcocks S_1 and S_2 in order a few drops of the liquid may be introduced into the tube. The increase of pressure due to the vapour may then be determined by arranging the position of the manometer tube, M, so that the air in AB is kept at constant volume. If sufficient liquid is present the maximum pressure of the vapour in the presence of air (or other gas) may thus be determined. It will be found to be the same as in a vacuum.

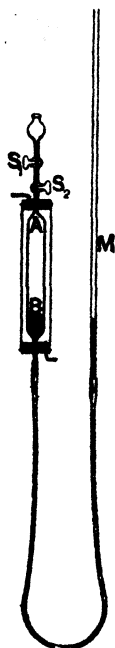

Fig. 95.

Exp. 89. Show that when two liquids, such as water and carbon bisulphide, which do not react chemically are present in the same space the maximum vapour pressure exerted is the sum of the maximum vapour pressures which would be exerted by the vapours of these liquids if separately confined at the same temperature.

Measure separately by the method of Exp. 81 the maximum vapour pressures of water and carbon bisulphide at the ordinary temperature and note values obtained.

Take a piece of barometer tubing, ABC, about 160 cm. long, bend it at the middle to form a U-tube, fill with mercury and invert into a cistern so as to form a double barometer tube of the form shown in Fig. 96, and pass one liquid, say water, up into one limb, AB, of the tube and the other liquid, carbon bisulphide, into the other limb, CB. The vacuum space will now be saturated with a mixture of the two vapours and the pressure depressing the mercury columns will be the pressure due to this mixture. This pressure should be measured and compared with the sum of the individual maximum



Fig. 96.

pressures of the vapours. It will be found that the pressure of the mixture of the two saturated vapours is equal to the sum of the maximum pressures exerted separately by these vapours.

An important point of difference between Exp. 88 and **Exp. 89** should be noted. In Exp. 88 the pressure of the air depends, in accordance with Boyle's Law, on the volume it occupies, and in order to get the same air pressure before and after the introduction of the vapour it is necessary to adjust to the same volumes in each case. The pressure of a *saturated* vapour at a given temperature is *the same whatever the volume it occupies*, and so no volume adjustment is necessary in Exp. 89.

If other experiments similar to those described above be performed, it will always be found that, in the case of a mixture of gases or vapours, or of both, between which there is no chemical action, the pressure of the mixture is the sum of the individual pressures of the constituents of the mixture, each constituent exerting, as a part of the mixture, the same pressure as it would exert if it alone occupied the whole space occupied by the mixture. Thus, if a small quantity of ordinary moist air be passed up into the "vacuum" space of a barometer tube the space becomes occupied by a mixture of nitrogen, oxygen, carbonic acid gas, water vapour, and mercury vapour. Each constituent of this mixture exerts a definite pressure, which is the same as it would exert if it alone occupied the whole space occupied by the mixture, and the pressure of the mixture is the sum of the pressures that would be exerted by these individual constituents separately.

These results have been formulated as laws which are usually known as Dalton's Laws. They may be stated as follows:—

(i) The maximum pressure exerted by a particular vapour, in a closed space, at a given temperature, depends only on that temperature, and is independent of the presence of other vapours or gases having no chemical action on it.

(ii) When several vapours and gases, having no chemical action on one another, are present in the same space, the actual pressure exerted by the mixture is the sum of the pressures which would be exerted by quantities of the

PROPERTIES OF VAPOUR.

constituents, equal to those which are actually present, if separately confined in turn in the same space.

The first of these laws deals with maximum pressure, and is therefore applicable only when the space is saturated with the vapour considered; the second law is applicable whether the space is saturated or not.

In the cases of saturated vapours these laws are only true when these vapours are the vapours of liquids which do not dissolve in or mingle with each other, *e.g.* water and carbon bisulphide. When the liquids mutually dissolve each other, as do water and alcohol, the vapour pressure of the mixture is less than the sum of the vapour pressures which they would separately exert at the same temperature. This could be tested by an experiment exactly similar to **Exp. 89.**

130. The pressure of mercury vapour. Mercury exerts a vapour pressure which although excessively small at ordinary temperatures is quite appreciable at higher temperatures. Accurate determinations of the maximum vapour pressure of mercury are very difficult to make. The following table gives the latest results:—

Temperature in Degrees Centigrade.	Vapour Pressure of Mercury in Mm. of Mercury at 0° C.
0	·0002
50	·0122
100	·276
200	17·81
300	248·6
356·7	760·0

These results explain why in barometer tube experiments the pressure of the mercury vapour necessarily present can be neglected at ordinary temperatures. Other liquids having very small vapour pressures are some oils, glycerine, strong sulphuric acid, etc.

131. Saturated and unsaturated vapours. When a space is saturated with vapour, in contact with its liquid, at a given temperature, this vapour exerts its maximum pressure for that temperature, and is also at its maximum density

for that temperature, because the greatest possible quantity of vapour has been introduced into the space. Vapour in this condition is sometimes called **saturated vapour**. When vapour, at a given temperature, exerts a pressure less than its maximum pressure for that temperature, it is said to be **unsaturated**.

Vapour in contact with its liquid, in a closed space, rapidly becomes saturated, for when a steady state is reached, the presence of the liquid is a proof that the limit of vaporisation has been attained.

The behaviour of saturated vapour under change of pressure and temperature should be considered. **Saturated vapour**, at any temperature, exerts the *maximum* pressure corresponding to the temperature, and hence any attempt to *increase its pressure*, e.g. by compressing it in a closed tube, must necessarily fail if any of the liquid be present; the only effect produced by such an experiment would be the condensation of part of the vapour in the space, because, the vapour being already at its maximum density, for the given temperature, any attempt at further compression causes it to pass gradually into the liquid state, while its pressure remains constant.

If liquid be not present, and in other exceptional cases, it is possible that the vapour should exert a greater pressure. It is then supersaturated. But supersaturation only occurs in practice if foreign matter, e.g. dust, is carefully excluded.

On the other hand, if saturated vapour is allowed to expand *in the presence of its liquid*, its pressure remains constant, and the liquid present is gradually converted into vapour, because, directly any small increase of volume takes place, the pressure of the vapour, in accordance with Boyle's law, tends to fall below the maximum pressure corresponding to the conditions of the experiment, and hence vaporisation of the liquid present becomes possible, and thus the pressure is maintained constant. If, however, there is no liquid present, the pressure of the vapour decreases on expansion in approximate agreement with Boyle's law, and the vapour becomes unsaturated.

The influence of change of temperature on a saturated

vapour also depends on whether its liquid is present or not. If a liquid and its vapour are heated in a closed space the liquid is converted into vapour, and the pressure increases at such a rate that, at any given temperature, the vapour present in the space saturates it, and the pressure exerted is the maximum pressure for that temperature. Similarly, if saturated vapour is cooled in a closed space, in contact with its liquid, the vapour condenses and the pressure decreases in such a way that, at any given temperature, the quantity of vapour present in the space is just sufficient to saturate it, and the pressure of the vapour is the maximum pressure for the given temperature.

If, however, saturated vapour is heated, in the absence of its liquid, it immediately becomes unsaturated and expands in accordance with Charles' law, or, if the heating takes place at constant volume, its pressure increases in the same way as that of an ordinary gas. On the other hand, if a saturated vapour is cooled in the absence of its liquid condensation does not always take place at once. The vapour may become supersaturated, and then obeys Charles' law.

Unsaturated vapours behave as ordinary gases under change of pressure and temperature—that is, so long as they remain unsaturated they obey both Boyle's and Charles' laws.* To understand this it should be remembered that, for any given vapour, there is, for each temperature at which it can exist, a definite maximum pressure corresponding to that temperature, and conversely, for any given pressure to which a vapour is subjected, there is a temperature at which this pressure is the maximum.

Hence, if an unsaturated vapour, at a given temperature, is subjected to increase of pressure, its volume decreases in approximate accordance with Boyle's law, until a pressure is reached which is the maximum pressure for the given temperature, and therefore at this pressure the vapour

* Unsaturated water vapour practically obeys Boyle's law until the pressure reaches four-fifths of the maximum vapour pressure (Regnault).

becomes saturated. Any further increase of pressure produces condensation, as described above, unless the conditions permit of supersaturation. Again, if an unsaturated vapour is cooled, at constant pressure, its volume will decrease in approximate accordance with Charles' law until a temperature is reached for which the given pressure is the maximum, and therefore at this temperature the vapour becomes saturated, and further cooling produces condensation.

132. Vapour and gas. An unsaturated vapour at temperatures considerably higher than the boiling point of the liquid from which it is derived is usually called a gas. The technical difference between a vapour and a gas turns upon the following point. If an unsaturated vapour is below a certain temperature, known as the *critical temperature** for the substance, it can always be condensed or liquefied by increasing the pressure until the maximum pressure for the temperature is reached. If, however, the vapour be above the critical temperature, it cannot be condensed by increase of pressure however great, and is properly called a *gas*. Hence a gaseous substance at temperatures below its critical temperature is properly called a *vapour*, but above the critical temperature it should be called a *gas*. The critical temperature for carbon dioxide is 30.9°C .; hence above this temperature carbon dioxide is a gas, but below this temperature, if apparently gaseous, it is the *vapour* of liquid carbon dioxide.

133. Vapour pressure thermometers. As pointed out in Arts. 126, 127, the maximum vapour pressure of a liquid depends only on the temperature of the liquid. If previous workers have determined and tabulated once for all the maximum vapour pressure of a liquid at all temperatures, then, as Kelvin pointed out long ago, the process may be reversed and a vapour-pressure determination may be used to find the temperature. This method is without several of the troublesome errors which complicate mercurial thermometry. A possible form of a vapour-pressure

* For meaning of critical temperature see Ch. XVII., Art 257.

thermometer for moderate temperatures is shown in the accompanying diagram (Fig. 97).

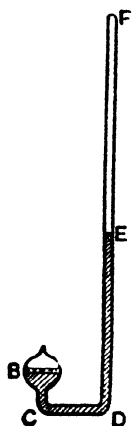

Fig. 97.

The lower half of the bulb B and a part of the tube C D F is occupied by mercury. There is a small quantity of ether above the mercury in B, all the air having been got rid of by boiling the ether for some time before sealing the top of the bulb. There is a vacuum above the mercury in D F. The difference in the levels of the mercury in B and in D F is a measure of the vapour pressure of ether at the given temperature. The difficulty in this method is to apply the proper correction for temperature (and therefore density) of the balancing column of mercury in D F.

✓ 134. Vapour density. Avogadro's hypothesis states that equal volumes of gases at the same temperature and pressure contain equal numbers of molecules. Since the molecular weight of hydrogen is 2, it follows that under the same conditions of temperature and pressure

$$\frac{\text{The density of a gas}}{\text{The density of hydrogen}} = \text{Half the molecular weight of the gas.}$$

The most direct method of determining the molecular weight of a gas is to find its density relative to hydrogen; in chemistry therefore vapour density plays a more important part than vapour pressure.

If the substance is a *gas under ordinary conditions* its relative density may be found by the simple process of taking a large glass vessel provided with a stopcock and weighing at (1) when evacuated, (2) when full of the gas at known temperature and pressure, (3) when full of hydrogen at known temperature and pressure.

Let these three weights be w_1, w_2, w_3 respectively. Then, if for simplicity we assume the temperatures and pressures to be the same in the two cases, we get

$$\frac{\text{Density of the gas}}{\text{Density of hydrogen}} = \frac{w_2 - w_1}{w_3 - w_1}.$$

The density of hydrogen at 0° C. and 760 mm. pressure is, however, a well-known physical constant—0·00009001 gm. per c.c.—which has been determined once for all. The third weighing may therefore be dispensed with if we find in its place the volume of the bulb, and this is easily done by filling it with cold water and weighing. Let the weight filled with water be w_4 gm.

Then
and

$$\text{Volume of bulb} = (w_4 - w_1) \text{ c.c.}$$

Weight of hydrogen which would fill the bulb at 0° C. and 760 mm.
= $(w_4 - w_1) \times 00009001$.

Now if t° C. and p mm. were the temperature and pressure when the flask was filled with the gas, the

Weight of the gas which would fill the bulb at 0° C. and 760 mm.

$$= (w_2 - w_1) \times \frac{273 + t}{273} \times \frac{760}{p}$$

and therefore

$$\frac{\text{Density of the gas}}{\text{Density of hydrogen}} = \frac{(w_2 - w_1) \times \frac{273 + t}{273} \times \frac{760}{p}}{(w_4 - w_1) \times 00009001}$$

Exp. 90. Find the density of dry air. How will you test if your pump will produce a vacuum? If the exhaustion is not complete, how would you modify your experiments to give you the required results?

135. Determination of Vapour Density. If the substance is a *liquid at ordinary temperatures* and pressures it must be vaporised by heat, and then from the volume, mass, pressure, and temperature of a quantity of the vapour formed the density may be found.

The chief practical methods employed in the determination of vapour densities are those of **Gay Lussac**, **Dumas**, and **Victor Meyer**.

(1) **Gay Lussac's (or Hofmann's) method.** In this method a known weight of liquid is introduced above the mercury in a barometer tube. The tube is then heated to a known temperature. The liquid evaporates, and its volume and pressure are then measured. The density can then be found as described above.

Exp. 91. Find the molecular weight of carbon tetrachloride. Set up the apparatus as shown in the adjoining figure (Fig. 98). A is a barometer tube, B a wider tube, used as a jacket, C a cistern of mercury, D a boiler to supply steam to B, and E an exit tube for the steam from B.

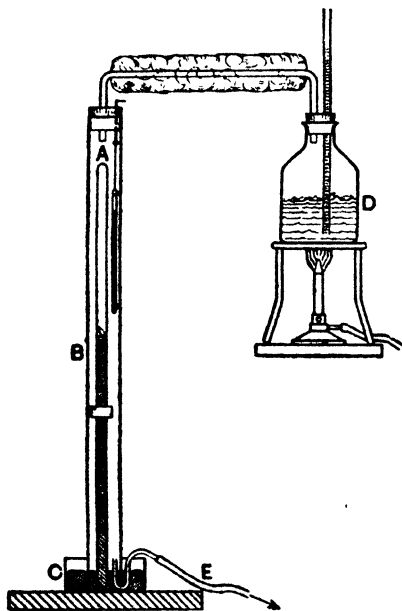

Fig. 98.

For A take a tube about 80 cm. long and 1.5 cm. diameter. Clean it and seal one end. Fill it with clean, warm dry mercury, and invert it in the cistern of mercury, thus forming a barometer. This barometer should be good enough to read to within one mm. of a standard barometer. Measure the height H with a vertical metre scale, or, better, by a mm. scale etched on a long piece of plate-glass mirror placed behind A.* Take the temperature of the mercury and then calculate the height of the barometer at 0°C .

Now take a small glass-stoppered bottle (1.5 cm. long is a convenient size), weigh it, partly fill it with the tetrachloride, and weigh again. The difference gives w gm. the weight of liquid taken. Push the bottle under the end of A. It quickly rises to the top of the mercury. Now pass steam through the jacket from D. A thermometer hung in B gives the temperature in B. As the inner tube gets hot the tetrachloride vaporises, and the mercury column falls.

* If a scale on a thick plate-glass mirror is employed all errors of parallax are easily avoided.

When the descent has ceased note the temperature $t^{\circ}\text{C}$., and read on the scale (1) the height of the top of the tube A, (2) the height of the mercury column, and (3) the level of the mercury in the cistern. The difference between (1) and (2) gives the length of the tube occupied by the vapour. The difference between (2) and (3) multiplied by $(1 - \cdot000182 t)$ gives the corrected height of the mercury column, and the barometric height less the height of the mercury column gives the pressure, p mm., of the vapour.

The steam is now turned off and A taken out and cleaned. Fill the part of A previously occupied by the vapour with water (or mercury), weigh the water (or mercury) and so calculate the volume, v c.c., of the vapour.

We have now the volume, v c.c., occupied by w gm. of carbon tetrachloride at $t^{\circ}\text{C}$. and a pressure of p mm. of mercury. The molecular weight of carbon tetrachloride is therefore

$$2 \times \frac{w}{v} \times \frac{273 + t}{273} \times \frac{760}{p} \times \frac{1}{\cdot00009001}.$$

In this description no allowance has been made for the expansion of the scale or the glass. The correction is negligible.

Example. Calculate the molecular weight of carbon tetrachloride from the following observations : Observed height of barometer at $19^{\circ} = 773\cdot5$ mm. Weight of carbon tetrachloride = $\cdot1066$ gm. Temperature of steam jacket = 101°C . Height of mercury column at 101°C . = $481\cdot5$ mm. Volume occupied by the vapour = $54\cdot30$ c.c.

Using the notation above

$$p = 773\cdot5 (1 - \cdot000182 \times 19) - 481\cdot5 (1 - \cdot000182 \times 101) \\ = 770\cdot9 - 472\cdot7 = 298\cdot2 \text{ mm.}$$

$$v = 54\cdot30 \text{ c.c.}, \quad t = 101^{\circ}\text{C}.$$

\therefore molecular weight of carbon tetrachloride

$$= 2 \times \frac{\cdot1066}{54\cdot30} \times \frac{374}{273} \times \frac{760}{298} \times \frac{1}{\cdot00009001} = 153.$$

What does the formula CCl_4 give ?

We have

atomic weight of carbon = 12

atomic weight of chlorine = $35\cdot4$

whence the molecular weight of $\text{CCl}_4 = 12 + 141\cdot6 = 153\cdot6$.

(2) **Dumas' method.** A light glass bulb of about 200 c.c. content is drawn out to a fine point in the form shown in Fig. 99. It is weighed; this gives the weight of the bulb, w gm., filled with air at the observed temperature and pressure. By gently warming the bulb, and then placing the orifice beneath the surface of the liquid whose vapour density is to be determined and allowing the bulb to cool again, a quantity of the liquid is introduced. This should be in considerable excess of that required to fill the whole bulb with vapour, as it is necessary to ensure the air being expelled from the bulb in the process of vaporisation; usually 5-10 c.c. will suffice.

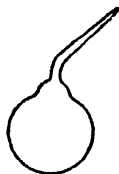

Fig. 99.

The bulb is now placed in a bath of heated liquid at a constant temperature $T^{\circ}\text{C}$. which should be at least 20°C . above that of the boiling point of the liquid under examination. When it is seen that the whole of the liquid has been transformed into vapour the orifice of the bulb is sealed by bringing the blowpipe flame to it. We have now, presumably, the glass bulb quite filled with the vapour at the temperature of the bath and the pressure of the atmosphere. After cooling the bulb is weighed; let its weight be w_1 gm.

The end of the sealed tube is then broken off under water; the water rushes in and completely fills the bulb. The latter is now again weighed, together with the piece broken off. This gives the weight, w_2 gm., of the bulb filled with water. Then the volume of the bulb = $w_2 - w$ c.c.*

Let p mm. of mercury and $t^{\circ}\text{C}$. be the pressure and temperature at the time of the first weighing. The weight of the air filling the bulb at this pressure and temperature

$$= (w_2 - w) \times 001293 \times \frac{273}{273 + t} \times \frac{h}{760} \text{ gm.} = x \text{ gm. say.}$$

Then the weight of the bulb if evacuated = $w - x$, and the weight of the vapour contained in the bulb at the second weighing = $w_1 - (w - x) = w_1 - w + x$.

* This is not quite exact, but the error is negligible compared with the errors of experiment and with the deviations from the gas-laws of vapours not far above their condensation temperatures.

This weight of vapour has a known volume—that of the bulb at a known temperature, that of the bath, and at a known pressure that of the atmosphere at the time the bulb was sealed. From these data the weight of 1 c.c. of the vapour can be calculated at 0° C. and 760 mm. on the assumption that the gas-laws can be applied. The result divided by .00009001 (the weight of 1 c.c. of hydrogen at 0° C. and 760 mm.) gives the vapour density of the substance.

Several corrections have been omitted in the above, but a high order of accuracy is not possible and, indeed, is unnecessary, since the purpose is only to decide whether the molecular weight is M , say, or some multiple of M .

Dumas' method as described above can only be used at temperatures below the softening temperature of glass (400° C.). Deville and Troost and others have substituted porcelain and metal for glass, and thus made the method applicable up to very high temperatures.

Exp. 92. Find the vapour density of chloroform by Dumas' method.

(3) **Victor Meyer's method.** This method also possesses the advantage of being applicable over a considerable range of temperature; it is also easy to manipulate, and the determination can be made with a small quantity of the substance.

The apparatus is represented in Fig. 100. It consists of a rather wide glass tube A narrowed in the upper part and then widened again near the top so as to admit an india-rubber stopper, the whole length of the tube being about 600 mm. Near the top of the narrow tube there is a side tube B C of the form shown. Surrounding the tube A is a wider tube D containing a quantity of water, naphthalene or other substance suitable for heating the glass bulb, according to the temperature required to volatilise the substance under examination, the bulb being so placed as to leave a clear space all round it.

A graduated tube E is filled with water, inverted, and got ready for placing over the end of the side tube. The stopper being inserted in its place, the jacket is heated, and

the temperature of the glass tube raised in this way to the vapour of the bath. Owing to the expansion of the air bubbles pass out into the graduated tube.

When the temperature becomes constant the bubbles cease, E is placed over the end of B C, the stopper is with-

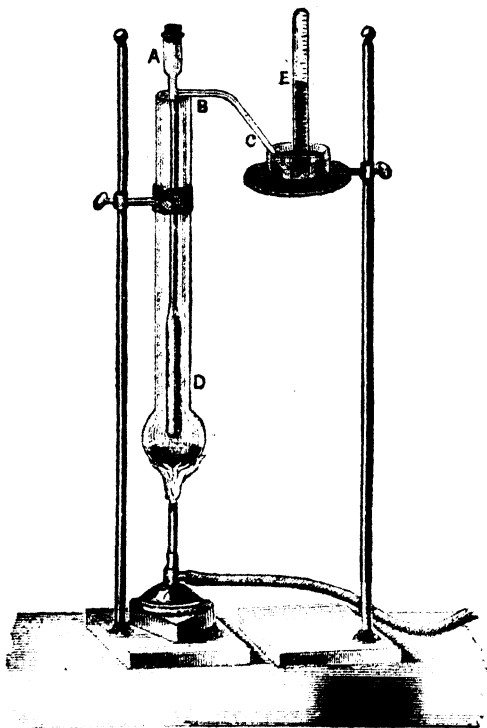

Fig. 100.

drawn from A and a weighed amount (up to .2 gm.) of the substance in a tiny bottle or bulb* is dropped in and the

* A little sand, glass, wool, or asbestos should be put in the bottom of the tube to prevent it being broken when the bulb is dropped in; also a device may be used by which the substance may be dropped into the tube without removing the stopper.

stopper immediately replaced. If the experiment is successful, the substance will be rapidly vaporised, and an equivalent volume, v c.c., of air will be expelled through the side tube. This is carefully measured and the pressure and temperature, t° C., of the room noted. If h mm. is the height of the water surface in E above the water surface in the vessel in which it stands and f mm. is the maximum vapour pressure of water at t° C., then the volume in cubic centimetres that the air in E would have at 0° C. and 760 mm. is given by

$$V = v \times \frac{273}{273 + t} \times \frac{p - \frac{h}{13.6} - f}{760}$$

If w gm. was the weight of liquid placed in the bottle, then the density D of the vapour compared with hydrogen under the same conditions is given by

$$D = \frac{w}{00009001 \times V}$$

Provided only the temperature of the jacket is constant and sufficiently high to ensure rapid vaporisation of the substance, the actual temperature employed need not be known. This will be clear if it be remembered that the volume of the air which is actually displaced and collected in the graduated tube is at the temperature of the room; the vapour of the substance occupies precisely the volume which this air would have occupied at the temperature of volatilisation. We have therefore the volume which the vapour would occupy if it could be collected as a vapour at the temperature of the room.

Exp. 93. Use Meyer's apparatus to find the density of ether vapour relative to that of hydrogen. Employ water in the jacket.

Example. A small bottle containing .054 gm. of ether was dropped down the inner tube of a Victor Meyer's vapour density apparatus. The air expelled occupied 18.0 c.c. at 21° C., the barometric height being 765 mm. and the height of water in the collecting tube being 140 mm. above the level of the water in the trough. Find the molecular weight of ether vapour.

From Regnault's tables (p. 279), $f = 18$ mm.

$$\begin{aligned} \text{Then } V &= 18 \cdot 0 \times \frac{273}{294} \times \frac{765 - \frac{140}{13 \cdot 6} - 18}{760} \\ &= 16 \cdot 2 \text{ c.c.} \\ \therefore D &= \frac{0 \cdot 54}{0 \cdot 000090 \times 16 \cdot 2} = 37. \end{aligned}$$

The molecular weight of ether is therefore 74.
Confirm this from the formula $(C_2H_5)_2O$.

136. Vapour Densities of Saturated Vapours. It is a harder task to determine the density of a saturated vapour than the density of an unsaturated vapour.

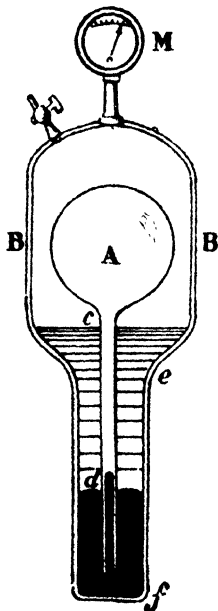

Fig. 101.

In order to determine the volume of unit mass of saturated steam at any temperature, Fairbairn and Tate used the apparatus shown diagrammatically in Fig. 101. The bulb A contains a known weight of water, and the outer vessel B contains sufficient water to secure saturation at all temperatures. The vessels contain no air, only water and water vapour, and the mercury which separates the water and vapour in A from that in B. The attached manometer, M, indicates the pressure in B, and it is evident from the figure that so long as the pressure in A is equal to that in B the level of the mercury inside and outside the tube $c d$ will not change.

In experimenting, the whole apparatus is raised in temperature until the mercury in $c d$ begins to rise. It is then known that at this temperature the mass of water in A is just sufficient to fill the volume of A as saturated steam at that temperature. The volume of A can be determined by calibration with mercury, and hence the volume of unit

mass of the saturated steam or, if required, the density of saturated steam may be determined at the observed temperature.

EXERCISES X.

1. What becomes of the steam which the boiling water in a kettle discharges into the air?

2. Give a sketch showing the general shape of the curve representing the relation between the vapour pressure and temperature of water.

3. A closed vessel is filled with dry air at a temperature of 15°C . and a pressure of 763.7 mm. of mercury. Without allowing any of the air to escape it is saturated with moisture. The temperature is now raised to 25°C . Find the total pressure.

4. A quantity of hydrogen is collected, over water, in a eudiometer tube. The height of the column of water left in the tube is 40.8 mm., and its temperature is 15°C .; find the pressure of the hydrogen in the upper part of the tube. (Take the height of the barometer at 758 mm.) The space occupied by the hydrogen is saturated with aqueous vapour. (Consult Table, p. 273.)

5. A quantity of dry air measures 1,000 c.cm. at 10°C . and 760 mm. pressure. If the same quantity of air is heated to 30°C . and saturated with aqueous vapour at that temperature, what must be the volume of the moist air, in order that the pressure may remain unchanged? (Tension of aqueous vapour at 30°C . = 31.55 mm.)

6. A bubble containing 0.01293 milligram of air is formed, 136 mm. below the surface of water at 80°C . Find its volume. [1 c.cm. of air weighs 1.293 milligrams at 0°C . and 760 mm. pressure; height of barometer = 750 mm.; remaining datum required may be obtained from table given on p. 273.]

7. Calculate the molecular weight of water from the following data obtained by Gay Lussac's method:—

Weight of water = 0.392 gm. Temperature of bath = 100.5°C .
Barometric height = 753.4 mm. Height of mercury column
(at 100.5°C .) = 235.5 mm. Volume of water vapour = 95.7 c.c.

8. Calculate the molecular weight of chloroform from the following data obtained from Dumas' method:—

Capacity of bulb = 127 c.c. Temperature of bath = 136°C .
Weight of vapour = 0.4524 gm.

9. Calculate the molecular weight of a substance from the following data obtained by V. Meyer's method:—

0.27 gm. of liquid sent off 11.1 c.c. of air at 11°C . and a total pressure of 33 ft. of water (atmospheric pressure = 34 ft. of water).

CHAPTER XI.

THE HIGHER CHANGE OF STATE.

VAPORISATION AND CONDENSATION.

137. Vaporisation and condensation. The process of change from the liquid to the vapour or gaseous state is known as *vaporisation*. The reverse process which takes place when a vapour changes into a liquid is known as *condensation*. The general phenomena of vaporisation and condensation are closely analogous to those of liquefaction and solidification, but the subject is complicated by the fact that a liquid gives off vapour at all temperatures and by the influence of external pressure. The simpler phenomena of the change are illustrated by the following experiments.

Exp. 94. Place some water in a flask fitted with a thermometer and tube as shown in Fig. 102. Arrange the thermometer so that the bulb is well immersed in the water, but not too close to the bottom of the flask. Heat the flask gently and observe the behaviour of the liquid and the readings of the thermometer.

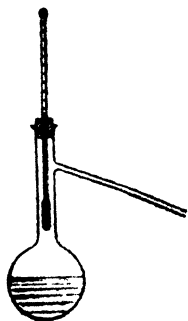

Fig. 102.

As the heating goes on the temperature rises and the vapour which is given off from the surface of the water at all temperatures is observed to condense in the neck and delivery tube of the flask and to form a cloud of condensed vapour at the mouth of the tube. As the temperature rises this escape of vapour at the surface becomes more marked, and small bubbles of air form and escape from numerous points on the walls of the flask.

Ultimately, however, the temperature becomes stationary at a fixed point (100° C.), and the liquid becomes agitated by the rapid escape of bubbles of vapour throughout its mass and is said to *boil*. If heating is continued the boiling goes on steadily and the water "boils away,"—that is, changes to water vapour or steam; but the temperature remains practically constant throughout the process. If the thermometer is now raised so that its bulb is not in the water but in the steam, it will be found that the temperature still remains constant at the same point. This constant temperature is called the *boiling point* of the water.

If the process of boiling is carefully watched it will be seen that the bubbles of vapour escape through the liquid from points on the walls of the flask and that the continuance of the process is facilitated by placing a few pieces of porous tiles, charcoal, broken glass or scraps of platinum foil in the flask.

Exp. 95. Repeat the above experiment (i) with alcohol and (ii) with ether, taking great care that the vapours do not go near the flame, as they are inflammable and explosive. The general progress of the experiment will be found to be the same for each liquid as for water. Each liquid will, however, be found to have a distinctive boiling point— 100° C. for water, about 78° C. for alcohol, and about 35° C. for ether.

From these and former experiments we see that

1. A liquid gives off vapour from its free surface at all temperatures by the process of *evaporation*.

2. A liquid changes by *boiling* or *ebullition* from the liquid state to the vapour state at a temperature which is constant throughout the process of ebullition. This constant temperature is the *boiling point* of the liquid under the conditions of the experiment.

3. Under given conditions each liquid has a distinctive *boiling point* characteristic of the liquid.

138. Condensation. During the process of condensation the phenomena of vaporisation are observed in the reverse order. The temperature at which condensation takes place is identical with the boiling point under the same conditions, and just as a liquid in boiling at a given tempera-

ture gives rise to vapour at the temperature of the liquid, so a vapour in condensing gives a liquid at the temperature of the vapour. Thus, for example, when water boils at 100° C. the steam produced is also at 100° C., and when this steam condenses the condensed water is, *when first formed*, also at 100° C.

In experimental work it is often necessary to facilitate condensation. This is usually effected by the aid of an arrangement known as a *condenser*. The simplest form of

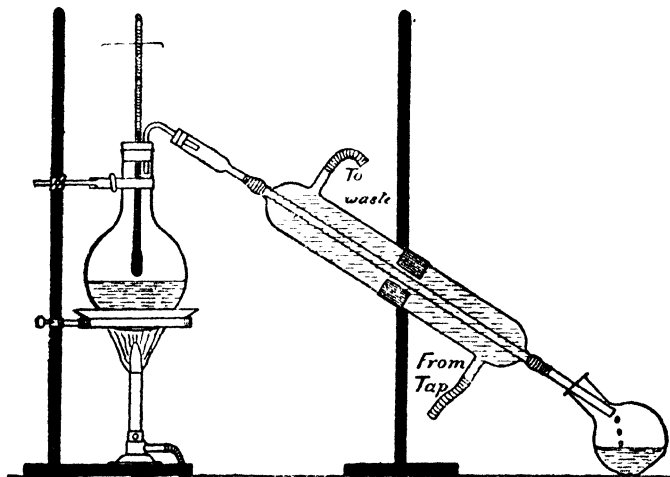

Fig. 103.

condenser is the double tube condenser (Fig. 103), which consists of an inner tube surrounded by a wider jacket tube. The vapour is passed into the inner tube and a current of cold water is passed through the jacket tube. The cooling effect of the cold water causes the vapour to condense, and the condensed liquid may be run off into a receiver, or, the condenser being placed sloping upwards, allowed to run back into the vessel in which the vapour is produced.

The condenser shown in Fig. 103 is commonly known as *Liebig's condenser*. Water or other liquid is boiled in

the upper flask and the vapour passes into the inner tube of the condenser. The condenser is kept cold by cold water which enters at the lower end and leaves at the higher end. The condensed liquid trickles down the condenser tube and collects in the lower flask.

Another form of condenser is that in which the vapour is condensed in a spirally coiled tube, known as a *worm*, which is surrounded by cold water (see Fig. 121).

Exp. 96. Fit up a simple form of condenser and use it to prepare distilled water from muddy water or water containing salts in solution. The jacket tube may conveniently be a wide glass tube (1 to $1\frac{1}{2}$ in. in diameter, 18 in. long) closed at its ends by corks through which the vapour tube and the water inlet and outlet tubes pass (see G, Fig. 105).

139. Influence of pressure on the boiling point of a liquid. The quantity of the liquid, the size and material of the flask,* the rate of heating may all be changed without causing any appreciable change in the boiling point, but a change in the pressure to which the surface of the liquid is exposed makes a material change in the boiling point. This fact is simply illustrated by the following well-known experiment.

Exp. 97. Perform Franklin's experiment. Boil water in a strong 20-oz. flask (Fig. 104) until all the air is expelled and its place taken by water vapour. Remove the source of heat, cork the flask tightly, and arrange the flask in an inverted position. Allow the flask to cool in this position until boiling entirely ceases. Then pour some cold water over it so as to condense the water vapour in the space over the water. It will be found that

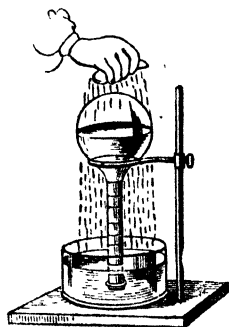

Fig. 104.

* The material of the flask has a slight effect on the temperature of the boiling liquid, but none on the temperature of the vapour arising from the boiling liquid,

the water again begins to boil vigorously and may be made to do so for some time.

The pressure on the surface of the water is evidently decreased by the condensation of the water vapour in the space over it, while it is also evident that the boiling point of the water is lowered, for the water was below 100°C . before the cold water was poured on, and the final temperature is therefore well below this.

Exp. 98. Heat water in a small copper boiler communicating through a condenser with another vessel, in which the pressure may be varied by pumping air into it or out of it. Fit a thermometer into the boiler so that its bulb is well immersed in the steam, and note how the boiling point indicated by it is affected by adjusting the pressure in the air reservoir so that the water boils under pressures *slightly* greater or less than the atmospheric pressure. It will be found that as the pressure increases the boiling point rises, and as the pressure decreases the boiling point falls.

These experiments show that the boiling point rises and falls with the external pressure.

It is now necessary to determine the boiling points for a number of measured pressures. There is considerable danger in experimenting in an elementary laboratory with boiling under pressures much greater than the atmospheric pressure, particularly with glass vessels, but for pressures

less than the atmospheric pressure investigation may be made safely and conveniently by the method of the following experiment.

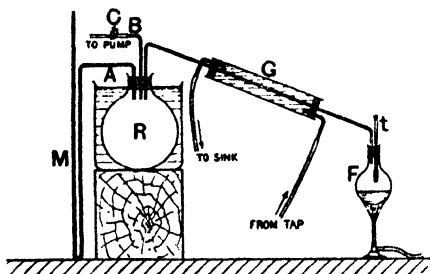

Fig. 105.

with a U-tube mercury manometer, M, by a tube, A, and with a water filter pump by a tube, C, which is provided with a clip. R is kept in a bath of cold water. Its use is to keep the pressure constant by damping out small oscillations in pressure. It also serves to introduce a large volume of air into the apparatus.

Exp. 99. Connect up a flask, F (Fig. 105), through a condenser, G, to a large bottle or flask, R, which communicates

The liquid to be experimented on is placed in the flask F, and the pressure under which it is made to boil is adjusted by means of the pump and measured by the manometer M. An accurate thermometer *t* fitted into F, so that its bulb is immersed in the vapour of the liquid, gives the boiling point corresponding to each pressure. The vapour produced during boiling condenses in the condenser G, and the condensed liquid runs back into the flask F.

The course of an experiment would be as follows:—Half fill the flask F with the liquid, say water, connect up the apparatus, turn on the water to the pump and condenser and heat the flask gently. When the column of mercury in the manometer tube on the reservoir side rises to a height of, say, 10 cm. or 20 cm. above that on the air side shut off the pump by a screw clip or tap at C. Allow the heating to go on till the water in F boils gently and the reading of the thermometer is stationary. When this is the case read the thermometer and the height of the manometer column simultaneously and record the readings. Then turn on the pump until the mercury rises another 10 cm. or so and take another pair of readings as before.

This process is continued until a number of readings of boiling points and their corresponding pressures are obtained, the pressure in each case being given by the difference between the height of the barometer and the observed height of the manometer column.

In an experiment of this kind the following readings might have been obtained—

Boiling Point.	Pressure in mm. of mercury.
96° C.	657
92° C.	567
88° C.	486
81° C.	370
74° C.	276
67° C.	204
59° C.	142

A study of these figures brings out a very important result. It will be found on comparison with the table on p. 207 that the external pressure for each boiling point is the same as the maximum vapour pressure for that temperature.

By using a metal boiler instead of a glass flask F and pumping air into R instead of withdrawing it the tem-

perature of boiling can be observed for pressures greater than atmospheric. Using metal vessels, Regnault determined in this way the maximum vapour pressure of aqueous vapour for temperatures over 100°C . (Art. 128).

140. The laws of ebullition may therefore be formally stated as follows:—

1. Ebullition takes place in a liquid at the temperature* for which the maximum pressure of the vapour is equal to the external pressure.

2. The temperature at which ebullition takes place, under a constant pressure, remains constant throughout the process. This temperature is known as the *boiling point* under the given pressure.

The temperature at which ebullition takes place under the normal pressure, which is equal to that due to 760 millimetres of mercury at 0°C . at sea level in latitude 45° , is the boiling point usually assigned to a liquid.

The latitude and height of the place of observation must be given for the pressure due to a liquid column is equal to the product of the height of the column, the density of the liquid and the acceleration due to gravity. The last factor depends on the latitude and height of the place of observation.

If λ is the latitude and h the height in *feet* of the place of observation above the sea level the normal pressure is

$$760\cdot000 + 1\cdot94562 \cos 2\lambda + 0\cdot0000455h$$

millimetres of mercury at 0°C .

For South Kensington $\lambda = 51^{\circ}\cdot30'$ and $h = 50$ ft, hence the standard pressure is

$$760\cdot000 + 1\cdot94562 \cos 103^{\circ} + 0\cdot0000455 \times 50,$$

which is equal to 759·56 mm., or practically 759·6 mm.

This means that a mercury column at South Kensington, 759·6 mm. in height, exerts a pressure equal to that exerted by a column 760 mm. in height in lat. 45° , hence the boiling point of water is 100°C . in South Kensington when the barometer (corrected for temperature) reads 759·6 mm.

* Temperature, in each of these laws must be understood to mean temperature of the *vapour* produced. The temperature of the *liquid* is slightly higher and is found to vary slightly with the nature of the surface of the vessel in which it is boiled.

3. Under given conditions each liquid has a distinct *boiling point* characteristic of the liquid.

141. These laws may be illustrated by the following experiments:—

✓ **Exp. 100.** Take a glass tube about a foot long and a quarter of an inch in diameter. Close one end and bend it as shown in Fig. 106, A. Fill the tube with mercury to about 15 millimetres from the open end. Fill the remaining portion with water. Close the tube with the thumb; by inverting the tube pass the water round the bend into the short limb where it rises to the top of the mercury. Now jerk sufficient mercury out of the open limb to bring the level of the mercury in this limb below that of the mercury in the short limb. Now place the tube, as shown in B, in the steam from water boiling in a wide-necked flask.

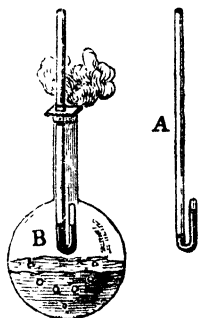

Fig. 106.

In a short time a portion of the water in the closed limb will be converted into steam, and this steam being saturated will exert the maximum pressure corresponding to the temperature of the surrounding steam. It will then be found that the mercury assumes the same level in both limbs of the tube, thus showing that the maximum pressure of water vapour at the boiling point is equal to the pressure under which boiling takes place.*

✓ **Exp. 101.** Take a siphon barometer tube, introduce sufficient mercury to give the barometric height, and complete the manufacture of the barometer in the usual way. Then add some water to the short limb, draw out the top to a fine hole, and by boiling the water for some time expel all the air from the space over the water

* Enough water must be placed in the short limb to saturate the space. If more than enough has been inserted a correction must be applied for the water left resting on the mercury in the short limb.

and close the end of the short limb by the blowpipe. When the limb is cold a layer of water will rest on the mercury while the space above contains only water vapour.



Now surround this limb with a steam jacket tube as shown in Fig. 107. Pass a steady current of steam from water boiling under the atmospheric pressure through this jacket tube and it will be seen that the steam formed in the wide limb of the barometer tube displaces the mercury into the narrow limb until the difference between the levels in the two limbs is exactly equal to the height of the barometer. This shows that the maximum pressure of the water vapour at the temperature of steam from water boiling under atmospheric pressure is equal to the atmospheric pressure.

As the difference in the level of the mercury columns is dependent only on the temperature of the water and its vapour such an instrument, if well made, acts as a thermometer. (See also Art. 133.)

✕ **142. Ebullition or Boiling.** The theory of this process can now be more fully considered. Consider a bubble of air in a liquid; its walls are formed by the liquid, and from these walls evaporation goes on until the space which they enclose becomes saturated with vapour. Let V denote the initial volume of air in the bubble, and P the hydrostatic pressure to which it is subjected. The value of P is determined by the position of the bubble in the liquid; if it is at a depth d below the surface, then P is equal to the atmospheric pressure, plus the difference due to a column of the liquid of height d .

As evaporation goes on into the bubble, the pressure exerted by the vapour increases, until it becomes equal to F , the maximum vapour pressure corresponding to the temperature of the liquid. But, as the total pressure in the bubble must, so long as the bubble remains in the same position, be equal to P , the pressure of the air in it must, according to Dalton's second law, be equal to $(P - F)$. Hence, if V' denote the volume of the air after the bubble is saturated with vapour, we have, by Boyle's law—

$$VP = V'(P - F), \text{ or } V' = \frac{VP}{P - F}$$

From this it is evident that V' increases as $(P - F)$ diminishes, and becomes infinitely great when $P - F = 0$; that is, when $F = P$. This means that when the temperature at any point in any liquid is such that the maximum vapour pressure for that temperature is equal to the hydrostatic pressure at that point, then if a bubble of air, gas, or vapour forms at that point its volume will tend to become infinitely great—that is, it will give rise to an infinite number of bubbles charged with vapour, which rise through the liquid, and escape at its surface. This process of formation of vapour in the interior of a liquid, and its final escape at the surface of the liquid, is called *boiling* or *ebullition*.

We here neglect the pressure due to the surface tension of the walls of the bubble. This pressure is equal to $\frac{2T}{r}$,* where T denotes the surface tension of the liquid-gas surface and r the radius of the bubble, and the pressure inside the bubble must be greater than the external pressure by this quantity. When r is very small $\frac{2T}{r}$ is evidently very great, and its magnitude explains why a very high temperature may be necessary to cause the formation of minute vapour bubbles in a perfectly gasless liquid.

If a liquid is placed in an ordinary glass vessel and gradually heated, the temperature rises, and evaporation goes on freely at the surface of the liquid. Before long, however, small bubbles of air are seen to form on the walls of the vessel, and from them minute bubbles are given off, and rise to the surface; as the temperature rises, this process goes on more rapidly, and bubbles are given off freely from the different points on the walls of the vessel, where air bubbles have been seen to form.

If the heat is applied from below, the upper layers of the liquid will be colder than the lower ones, and it will be noticed, at a certain stage of the heating, that bubbles given off from points near the bottom of the vessel are condensed in the upper colder layers before reaching the

* See Wagstaff: *Properties of Matter*, § 269.

surface. The condensation of these bubbles of vapour is accompanied by a peculiar noise familiarly known as *singing*. On further heating the temperature of the liquid becomes more uniform, and large bubbles of vapour rise rapidly to the surface and escape. The liquid is thus kept in a state of agitation known as *boiling*.

It thus appears that the commencement of ebullition in a liquid is dependent on the presence of bubbles of air, or other gas, in the liquid or on the walls of the vessel in which it is heated. Experiment shows this to be the case; provided no bubbles of air form, the liquid may be raised to a temperature considerably above its boiling point without entering into ebullition; but if, in any way, a bubble of vapour or any gas is introduced, boiling at once takes place with explosive violence.

On the other hand, the presence of a very minute quantity of air or other gas in a liquid is sufficient to produce continuous boiling as long as any liquid is left. This can be shown by dropping a small glass bulb containing air and drawn out to a very fine hole into a liquid heated to its boiling point; the air in the bulb will give rise to thousands of vapour bubbles without being appreciably diminished in volume.

The same purpose is also served by the fragments of charcoal, porous pot and broken glass used to steady the boiling of liquids in many chemical and physical operations.

▷ 143. **Papin's digester.** If heated in a closed vessel water may be raised to very high temperatures. This fact is often of great utility in the industrial arts. An instance of its application is found in **Papin's digester**, which is used for the purpose of subjecting substances to the action of water at a temperature considerably higher than 100°C . It consists of a strong bronze vessel, covered with a lid secured by a screw and fitted with a safety valve, to prevent the internal pressure becoming greater than the vessel can sustain. Again in the boiler of a steam engine the temperature rises considerably if the steam is not drawn off. For example, if the gauge registers 55 lbs. per sq. in. the temperature within is about 150°C . (Cf. Table, p. 207.)

144. **The hypsometer.** This instrument (Fig. 108) is merely a small vessel conveniently constructed for observing the boiling point of water at any place. It consists of a small boiler heated by a spirit lamp, and is provided with a delicate thermometer which is surrounded by steam in the upper part of the vessel. The steam escapes at the top by a small side tube which communicates with the outer air, so that ebullition takes place under the atmospheric pressure. The hypsometer is used for the determination of heights, and is very convenient for this purpose because of its portability.

The principle of its use for such determinations is based on the fact that the temperature of ebullition depends on the external pressure, and that when the former is known the latter is determined, and is equal to the maximum vapour pressure at that temperature; hence, if we find the temperature at which water boils at the sea level, and at a place the height of which we wish to determine, we can, by reference to a table of maximum pressures of aqueous vapour, find the corresponding atmospheric pressures, from which the required height can be calculated.

An approximate relation between altitude and atmospheric pressure is given by

$$h = 18400 (\log p_1 - \log p_2)$$

where h is the difference in altitude expressed in metres of two stations and p_1, p_2 are the normal atmospheric pressures at lower and upper station respectively. Expressing the pressures in terms of the boiling points of water we get

$$h = 295 (t_1 - t_2), \text{ approximately,}$$

where t_1, t_2 are the normal boiling points of water at the lower and upper station respectively. If the lower station is at the sea level $t_1 = 100^\circ\text{C}$. very nearly, and h is the height of the upper station above sea level.

The fact that water boils below 100°C . at high elevations is a source of inconvenience in cooking. In such cases a modified form of Papin's digester is used.



Fig. 108.

Example.—The average value of the boiling point of water on the top of Snowdon is 96.3°C . Find the height of the mountain. Applying the formula of Art. 144 we get

the height = 295×3.7 metres = 1091 metres = 3580 feet.

TABLE SHOWING THE MAXIMUM PRESSURE OF AQUEOUS VAPOUR BETWEEN 85°C . AND 102°C . (*Regnault.*)

Temperature, Centigrade.	Pressure in mm. of Mercury at 0°C .	Temperature, Centigrade.	Pressure in mm. of Mercury at 0°C .
85	433.0	94	610.7
86	450.3	95	633.8
87	468.2	96	657.5
88	486.7	97	682.0
89	505.8	98	707.3
90	525.5	99	733.3
91	545.8	100	760.0
92	566.8	101	787.6
93	588.8	102	816.0

TABLE SHOWING THE BOILING POINT OF WATER AT PRESSURES NEAR THE NORMAL ATMOSPHERIC PRESSURE.

(*Regnault.*)

p is given in mm of mercury at 0°C .

<i>p</i>	$t^{\circ}\text{C}$.	<i>p</i>	$t^{\circ}\text{C}$.	<i>p</i>	$t^{\circ}\text{C}$.	<i>p</i>	$t^{\circ}\text{C}$.
740	99.26°	750	99.63°	760	100.00°	770	100.36°
741	99.30	751	99.67	761	100.04	771	100.40
742	99.33	752	99.71	762	100.07	772	100.44
743	99.37	753	99.74	763	100.11	773	100.47
744	99.41	754	99.78	764	100.15	774	100.51
745	99.44	755	99.82	765	100.18	775	100.55
746	99.48	756	99.85	766	100.22	776	100.58
747	99.52	757	99.89	767	100.26	777	100.62
748	99.56	758	99.93	768	100.29	778	100.65
749	99.59	759	99.96	769	100.33	779	100.69
750	99.63	760	100.00	770	100.36	780	100.73

145. Determination of the boiling point of a liquid.

Exp 102. Determine the boiling points of various liquids such as ether, alcohol, turpentine, acetic acid. Take a clean, rather small flask (Fig. 11 or 12), preferably provided with a side tube, and fit a good thermometer through a cork which just fits the neck of the flask.* Place some fragments of tile in the flask to facilitate boiling, and then nearly half fill the flask with the liquid. Mount the flask over a Bunsen burner, the flame of which is protected from draughts by a chimney, and heat the liquid to boiling.

When the liquid is boiling adjust the thermometer so that the top of the mercury column is just above the cork, taking care, however, that the bulb is not immersed in the liquid. As soon as the temperature of the thermometer becomes steady read it; it is the boiling point at the pressure inside of the flask. If the boiling has not been too rapidly carried on the inside pressure is equal to the atmospheric pressure which may be read, and the boiling point corrected to a pressure of 760 mm. by means of tables.



Fig. 110.

condenser (Fig. 103).

If the liquid is obtainable only in very small quantity,

* Many text-books insist on a double-walled tube being used, the thermometer being inside and vapour in contact with both sides of the inner wall. There is, however, no necessity for this, for it has been shown that the latent heat of the vapour keeps the thermometer, on which a liquid film forms, accurately at the boiling point.

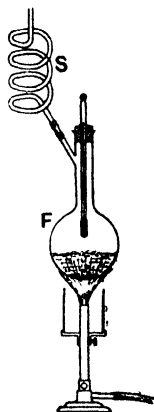

Fig. 109.

the flask may be replaced by a test tube as shown in Fig. 110.

TABLE OF BOILING POINTS AT THE PRESSURE EQUAL TO THAT OF 760 MM. OF MERCURY AT 0° C.

Liquid air	- 191° C.	Distilled water.....	100·0° C.
Liquid carbonic acid ...	- 78·2	Spirits of turpentine	130·3
Liquid ammonia	- 38·5	Oil of turpentine	159·1
Liquid sulphur dioxide	- 10·0	Aniline	184
Ether (ethyl)	35·0	Naphthalene.....	220
Chloroform	60·2	Sulphuric acid	325·0
Alcohol (ethyl).....	78·3	Mercury.....	356·7
Benzene.....	80·4	Sulphur	444·5

Example. In an experiment performed at South Kensington a thermometer read 100·8° C. when placed in the steam from water boiling under the atmospheric pressure of 764·6 mm. of mercury (at 0° C.). Find the correction to be applied to the thermometer at this part of the scale.

By Art. 140 the boiling point of water at South Kensington is 100° C. when the barometer reads 759·6 mm. If, therefore, we increase the observed barometric height by 760·0 - 759·6 or 0·4 mm. we can apply Regnault's tables. This gives us a pressure of 765·0 mm. at which the boiling point is 100·18° C., or practically 100·2° C. Thus the given thermometer reads 0·6° C. too high, or the correction at 100° C. is - 0·6° C.

- 146. Elevation of the boiling point of salt solutions.

We saw in Art. 119 that the presence of a salt in solution lowered the freezing point below the normal freezing point of the solvent. Similarly the presence of salt in solution elevates the boiling point. The thermometer is, of course, placed with its bulb in the solution; the temperature of the vapour given off quickly falls to that of the vapour from the pure solvent. For weak solutions the elevation is proportional to the concentration and inversely proportional to the molecular weight.

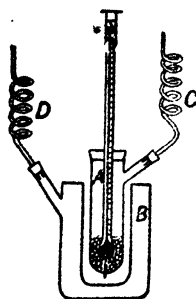

Fig. 111.

The most accurate apparatus for determining boiling-point elevations was devised by Beckmann. The elevation of temperature is measured by a thermometer of the same

kind as that used to measure the depression of the freezing point of salt solutions (Arts. 21, 119). The solution is boiled in a tube A (Fig. 111), having a platinum wire fixed through the bottom, and the tube is partly filled with glass beads. This arrangement promotes ebullition and prevents superheating of the liquid. The inner tube is surrounded by a wider one B, in which the same solution is kept boiling.

Thus the amount of direct heat which has to be supplied to the inner tube is very small, and the tube is further protected by asbestos from the direct action of the flame, again to prevent superheating. Both the inner and outer vessels are provided with reflux condensers C and D (*i.e.* condensers which return the distilled material to the vessel from which it came). With this apparatus it is possible to determine boiling points to within one-thousandth of a degree.

For details of the use of this apparatus in the determination of molecular weights a text-book of physical chemistry should be consulted.

Exp. 103. Show how the boiling point of a salt solution depends on the strength of the solution.

Take a flask provided as shown with a cork-fitted thermometer and an exit tube which ends in a piece of indiarubber tubing which may be closed with a screw clip. Weigh the flask, etc., when empty. Add about 15 gm. common salt, weigh again. Then add about 300 c.c. water. Dissolve the salt. Push the bulb of the thermometer well into the solution. The clip being open bring the solution to the boil. Boil gently (prevent bumping by a piece of porous earthenware), and when the thermometer is mounting very slowly, read the temperature. Immediately withdraw the flame and close the clip. As the flask cools open the clip now and then to equalise the pressure in the flask to atmospheric or the flask will break.

Read the barometer and calculate the true boiling point of water at the existing atmospheric pressure. When the flask is cold weigh it again and so calculate the weight of *water* in the solution. We can now calculate the elevation of the boiling point for a known concentration of salt in water. Open the clip, boil again, and when the thermometer has risen about half a degree read it, and repeat

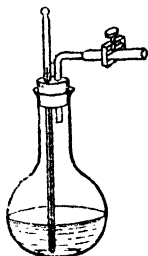

Fig. 112.

the series of observations. Take 4 or 5 sets of readings this way until the boiling point is about five degrees above that of pure water at the same pressure.

Plot a curve showing how the elevation of the boiling point depends on the concentration (calculate the concentration in gm. of salt per 100 gm. water), and calculate the elevation produced for a solution containing $\frac{1}{100}$ gm. molecule of salt per 100 gm. water. (It will be about $\frac{1}{10}^{\circ}$ C.)

Exp. 104. Bubble a current of steam from a boiler through an aqueous solution of a salt, *e.g.* sodium or calcium chloride. Insert the bulb of a thermometer into the solution and note the rise of temperature. The temperature of the solution rises above the temperature of the entering steam and reaches the boiling point of the salt solution for the existing concentration.

Explanation. The boiling point of a salt solution is the temperature at which it is in equilibrium with the vapour rising from it. The vapour pressure of a solution is less than that of the pure solvent at the same temperature. Hence to be in equilibrium with steam at 100° C. (assuming the atmospheric pressure to be normal) the salt solution must be above 100° C. If the solution is below 100° C. some of the steam condenses in it and the solution becomes warmer. The steam leaving such a solution is at a temperature greater than 100° C., but within a centimetre or so of the surface it falls to its normal temperature owing to condensation on the walls of the vessel, etc. A thermometer hung in the vapour from a boiling solution indicates therefore the boiling point of the pure solvent; the thermometer must be placed in the solution itself if the boiling point of the solution is required.

147. Change of volume accompanying change of state from liquid to vapour. Let any liquid boil and notice the large quantity of vapour produced. It is evident that when a liquid changes to a vapour there is a very great increase in volume. In the case of water, for example, the volume of the steam at 100° C. and atmospheric pressure is nearly seventeen hundred times the volume of the water from which it is produced; that is, a cubic inch of water produces about a cubic foot of steam.

The following curve (Fig. 113) shows the changes in volume which occur when 1 gramme of ice at -20° C. is

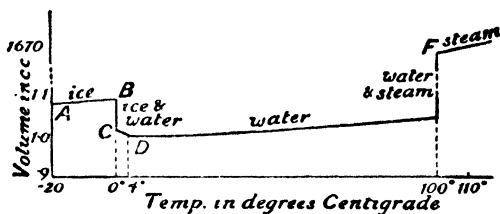

Fig 113.

heated to steam at 110° C. at atmospheric pressure (760 mm.).

The curve is plotted from the following data:—

Temperature. Degrees Centigrade.	Volume of 1 gm. in c.c.
- 20 } Ice	1·0900
0 } Ice	1·0906
0 } Water	1·0001
4 } Water	1·0000
50 } Water	1·0120
100 } Water	1·0432
100 } Steam	1672
110 } Steam	1716

The steam line is of course directed towards a point on the temperature axis situated at 273° C. below zero.

148. Evaporation. It has been shown that, at all temperatures, vaporisation takes place in a closed space until that space is saturated with vapour. If, however, the process goes on in the open air it becomes continuous, because it is practically impossible to saturate the atmosphere with vapour. This process of vaporisation in an unlimited atmosphere has been called *evaporation*.

Evaporation takes place exclusively at the free surface of the liquid. The vapour formed at the surface pene-

trates into the adjacent layer of air, and from thence it passes into the next layer, and so on until the vapour is diffused throughout the atmosphere at a uniform rate such that any given layer passes on as much vapour as it receives.

This process is somewhat modified if the air is in motion, for then the layer in contact with the liquid is continually being renewed, and evaporation takes place more rapidly, because each layer as it comes in contact with the liquid takes up only a small quantity of vapour, which is at once carried away and thus diffusion is assisted; moreover evaporation always takes place into a comparatively "dry" atmosphere, for the successive layers pass on before becoming nearly saturated.

Evaporation is also rapidly promoted if a rapid succession of air bubbles be blown through the liquid, for each air bubble exposes a large surface to the liquid and is then immediately swept away.

The following experiments illustrate some of the more important phenomena of evaporation:—

Exp. 105. Put a small quantity of ether into a watch-glass and set it on the table. In a few minutes the ether will have disappeared by evaporation.

Exp. 106. Dip a piece of filter paper or a handkerchief in water and hang it out to dry. In a short time, which depends greatly on the weather, the water will have "dried" out of the fabric by evaporation.

Exp. 107. Put equal quantities of water, alcohol, and ether in similar crystallising dishes and allow them to evaporate under the same conditions. The ether evaporates more rapidly than the alcohol, and the alcohol more rapidly than the water.

Exp. 108. Put equal quantities of water (or alcohol or ether) in crystallising dishes of different diameters and allow them to evaporate under the same conditions. Note the times taken for the dishes to completely dry up. The amount of liquid evaporating per second will be found to be proportional to the diameters, and not as one would suppose on first thoughts, viz. proportional to the surface areas.

Exp. 109. Put equal quantities of ether in two equal crystallising dishes. Direct a gentle current of air from a foot bellows over the surface of the ether in one of the dishes. The ether in this dish evaporates much more quickly than in the other.

Exp. 110. Put equal quantities of alcohol (methylated spirits will do) into crystallising dishes of the same size, and expose one to evaporation in a warm living-room and the other in a cool cellar, but under otherwise similar conditions. Evaporation is much more rapid from the former than from the latter.

From the above experiments we conclude that different liquids evaporate at different rates, and that evaporation can be greatly quickened by (1) renewing the air in contact with the surface, (2) warming the liquid and air, (3) increasing the surface of the liquid exposed to the air.

The evaporation of water is a familiar and important process. All the aqueous phenomena of meteorology have their origin in the evaporation which goes on from the water surfaces of the earth into the atmosphere. Such processes are so apparent that it is hardly necessary to call them to mind. Some of them will, however, be dealt with in detail in Ch. XII.

149. Conditions favourable to evaporation. From what has been said above, it may readily be deduced that the rate at which evaporation takes place is favoured by—

1. Dryness of the air. The less the quantity of vapour present in the air the more readily does evaporation go on into it.

2. Low atmospheric pressure. Low pressure facilitates the escape of vapour from the surface of the liquid.

3. High temperature both of the liquid and the air. The higher the temperature of the liquid the greater the pressure exerted by the escaping vapour, and the higher the temperature of the air the greater the quantity of vapour it will contain before saturation is reached.

4. Large extent of free surface of the liquid.

5. Low boiling point of the liquid. The lower the boiling point the greater the pressure of the vapour at ordinary temperatures.

6. Renewal of the air in contact with the surface of the liquid.

150. Cold caused by evaporation. During evaporation the latent heat necessary to effect the required change of state is absorbed from the liquid itself and its surroundings.

This absorption of heat cools the liquid, but, as evaporation takes place at all temperatures, the process goes on, and a continuous fall of temperature is thus produced. Under favourable conditions this fall of temperature may go on until the freezing point of the liquid is reached and the liquid freezes. The following experiments illustrate the cooling effect:—

Exp. 111. Put a little ether in a thin watch-glass (or in a small thin beaker), and set it up on a wood block with a small drop of water between it and the block. Blow a rapid stream of air through the ether. Rapid evaporation is promoted, the ether in turning from liquid to vapour absorbs its latent heat from the glass, wood, and film of water between, and after a short time so much heat will have been abstracted that the water will freeze and the watch-glass and block form one piece.

Exp. 112. Perform Leslie's experiment. Place a shallow dish, containing a little water, and another dish, containing strong sulphuric acid, under the receiver of an air pump. Exhaust. The water rapidly evaporates, and the vapour formed is absorbed by the sulphuric acid, thus ensuring continuous and rapid evaporation of the water. This process cools the water, and ultimately a thin layer of ice forms on its surface.

Another instance of the application of the cold produced by evaporation is the method adopted in India for keeping drinking water cool. The water is placed in porous earthenware vessels, through which it slowly percolates; evaporation takes place from the outer surface of the vessel, and the absorption of heat thus produced keeps the water in the desired state of coolness. The same effect may be produced in any vessel by wrapping a wet cloth round it.

151. Pressure of vapour in a system of communicating vessels at different temperatures. Let A and B (Fig. 114) be two bulbs connected by a tube C. Suppose further that A and B both contain some liquid and that the remaining space contains only the vapour of that liquid.

Let A and B be placed in baths of temperatures t_1 and t_2 , t_1 being greater than t_2 , and suppose p_1 and p_2 to be the maximum vapour pressures at t_1 and t_2 , p_1 of course being greater than p_2 .

Suppose a closely fitting piston to be placed in C. Then since p_1 is greater than p_2 the piston will be forced towards B. As it moves towards B it tends to increase the pressure in B, but since the pressure

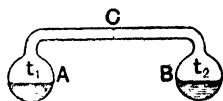

Fig. 114.

cannot rise above p_2 some of the vapour in B will be condensed. Similarly its movement away from A causes some of the liquid in A to evaporate. This action proceeds whether the piston is there or not, and so we see that the effect of A and B being at different temperatures is that there will be a continual transference of vapour from A to B until all the liquid in A has evaporated and the pressure throughout the vessel is p_2 , the maximum vapour pressure corresponding to the lower temperature t_2 .

This explains the principle of Regnault's method of determining the maximum pressure of water vapour below 0°C . (Art. 128), the action of Wollaston's cryophorus (Art. 152), and the possibility of distillation (Art. 153).

Suppose A contains pure water and B contains a solution of a salt, say calcium chloride, in water, the whole instrument and its contents being initially at 100°C . Then since the vapour pressure in B is less than the vapour pressure in A, distillation will occur over from A to B. Heat will be used up in A in this process and heat will be given to B. Hence the temperature of the pure water will fall and that of the solution will rise. This process will go on until the temperature of the solution is so much above that of the pure water, that its vapour pressure is equal to that of the water when equilibrium occurs.

Now reconsider Exp. 104.

152. Wollaston's cryophorus. A form of apparatus known as the *cryophorus* was devised by Wollaston to illustrate the cooling effect of evaporation. It consists of a bent tube (Fig. 115) with a bulb at each end. It con-

tains only a small quantity of water and water vapour. All the water being passed into the bulb B, which should now be not more than half full, the bulb A is surrounded, as shown in the figure, by a mixture of ice and salt. The cold surface of the ice condenses the vapour in A as rapidly as it is formed in B, and in a short time the absorption of heat is sufficient to cool the water in B down to the freezing point and finally convert it into ice.

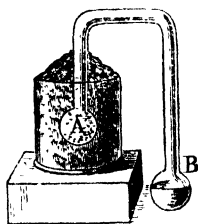

Fig. 115.

Several complicated forms of apparatus have been constructed for freezing water on the principle illustrated by these experiments; notably Carré's apparatus for freezing by sulphurous acid, and also Carré's ammoniacal freezing apparatus.

153. Condensation and distillation. Distillation is a combined process of vaporisation and condensation; it is much used for obtaining pure or distilled water from ordinary tap water, or from salt water. It is also of frequent use for manufacturing and chemical purposes. The liquid to be distilled is heated in a suitable vessel and the vapour produced passes through a long spirally coiled tube or worm, surrounded by cold water, or is, in some other way, cooled to a temperature sufficiently low to cause the vapour to condense. The liquid thus produced is collected in a vessel into which the worm opens; it is free from all solid matter contained, either in suspension or solution, in the original liquid.

154. Vapour jackets. One of the simplest methods of keeping a body at constant temperature is to put it in a vessel surrounded by the vapour of a liquid boiling at constant pressure. We have already used such a chamber in the determination of specific heats. If the pressure is normal the temperature is the normal boiling point of the liquid used, but the pressure may of course be regulated so as to give any temperature required. The apparatus in general use is very similar to that shown in Fig. 104, the

only difference being that the flask F is replaced by a boiler, into the top of which is sealed the chamber whose temperature is to be kept constant.

155. Liquefaction of gases. Experimental evidence shows that the properties of gases are continuous with those of unsaturated vapours at temperatures considerably above the boiling points of their liquids. Hence, if we wish to condense any given gas, the method of doing so is indicated by the results, in the two cases referred to above, in connection with unsaturated vapours. All gases and vapours may be liquefied by the combined application of pressure and cold, and, in many cases, the application of either pressure or cold separately produces the desired effect. As a simple example, suppose we have unsaturated water vapour, at a temperature of 200°C ., and under the normal atmospheric pressure, and we wish to liquefy it; three courses are open—

(1) *The application of pressure at constant temperature.* We know that condensation sets in, at any temperature, as soon as the maximum vapour pressure for that temperature is reached. Hence, in this case, water would begin to form when the pressure applied became equal to that due to 11690 mm. of mercury (see Table, p. 207).

(2) *Application of cold at constant pressure.* In this case condensation will take place as soon as a temperature is reached, for which the existing pressure is the maximum pressure, that is, water will be formed when the vapour is cooled to 100°C .

(3) *Combination of (1) and (2).* In this way condensation might be produced by cooling the vapour down to, say, 150°C ., and increasing the pressure to 3581 mm. of mercury (see Table, p. 207).

The method adopted in any particular case depends on circumstances; it is very much easier to apply pressure than to cool a gas down to a very low temperature, but a gas is distinguished from a vapour by the property that it cannot be liquefied by pressure alone as it is above its critical temperature (Art. 132). Hence, unless a gas is first cooled, at least, below its critical temperature, it is impossible to

liquefy it by the application of pressure alone; and this explains why oxygen, hydrogen, nitrogen, air, etc., so long withstood all attempts at liquefaction; the critical temperatures of these gases are so very low, that it is only in recent years that experimenters have been able to cool them below their critical temperatures, and thus effect their liquefaction at very high pressures (see Ch. XIX.).

156. The Spheroidal state.

Exp. 113. Take a plane metal plate, place it quite horizontal on a tripod and heat it with a Bunsen flame. When its temperature is just a little above that of boiling water, drop gently from a pipette a drop of water on the plate. It boils away with a hissing noise.

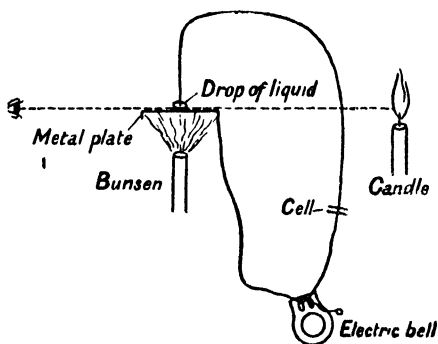

Fig. 116.

Now heat the plate much above the boiling point of water and again place a drop of water on the plate. The drop does not boil nor hiss, but assumes the form of a flattened globule just like a globule of mercury. Evaporation occurs very slowly and the drop will remain as such for a long time.

The drop is said to be in the *spheroidal* state, and the reason why evaporation is so slow is that the drop is buoyed up by a cushion of its own vapour through which heat only travels slowly, too slowly in fact to heat the

liquid to its boiling point. This vapour, as it is formed, is gradually wafted away, and so the water gradually evaporates. If the plate is allowed to cool there will arrive a time when the drop comes in contact with the plate and violent ebullition occurs.

Exp. 114. To show that the drop is not in contact with the metal plate.

If the plate is quite flat it is easy to see between it and the drop (see Fig. 116).

Another method is to put one end of a fine wire into the drop and to connect the other end through an electric bell and a voltaic cell to the plate. When the water is in the spheroidal state the bell is silent. Withdraw the Bunsen flame; when the violent ebullition occurs the bell rings, showing that contact occurs between the water and the plate.

Exp. 115. Make the end of a poker red-hot and dip it into cold water. For some time no ebullition occurs, the water around the poker being in the spheroidal state. When the poker is sufficiently cooled violent ebullition occurs. In the same way a hot metal dish may be got to rest on the surface of water.

The experiment may also be repeated with two liquids; the only necessary condition is a sufficiently elevated temperature. Thus if a bath of oil of suitable density is heated to about 120° C. and water dropped into it from a pipette, the water forms spheres which do not boil away. If, however, the spheres are touched by a needle, which thereby breaks through the vapour films, violent ebullition occurs.

Exp. 116. Pour a little liquid air into the palm of the hand. The liquid remains in the spheroidal state and does not feel as intensely cold as it really is. It is advisable to shake the globule off before the skin underneath it becomes frozen.

As examples of spheroidal state we have the laundress' mode of testing the temperature of a hot iron, the licking without injury of a white-hot iron bar, and the fact that the hand if clean and damp may be dipped into hot molten lead without injury.

157. Sublimation. Under ordinary conditions of pressure some substances do not melt, but "sublime," *i.e.* pass direct from the solid state to the vapour state, and *vice versa*. Examples are iodine, arsenic, sulphur, benzoic

acid, ice (below 0°C .), camphor. By a suitable adjustment of pressure the substance can be made to pass through the liquid state.

Exp. 117. Take a small piece of iodine, place it in a dry test tube, and heat gently in a flame. It is easily seen that the iodine does not melt, but passes off into a violet vapour, which soon fills the tube: some of this vapour will condense again on the cooler portions of the tube, forming a thin layer of the solid.

The same process takes place more slowly at ordinary temperatures, as may be at once verified by examining a bottle in which iodine has been kept for some time.

Exp. 118. Take two watch-glasses of the same size and fitting well around the edges when facing each other. Put a few crystals of benzoic acid into one glass, then lay a sheet of filter paper right over the glass and turn the other glass upside down over it (Fig. 117). Clamp the glasses together with a thin brass clip. Now gently warm



Fig. 117.

the lower glass. The benzoic acid sublimates, passes through the filter paper, and appears as crystals on the upper glass. The experiment succeeds better if the upper glass is kept cold by a piece of wet filter paper.

Exp. 119. Place some bar sulphur in a retort, R (Fig. 118), and lead the stem of the retort into a large flask, F, over which a stream

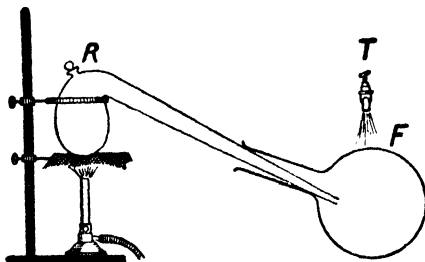

Fig. 118.

of water flows to keep the interior cool. Heat the sulphur, and it will be found that sulphur vapour passes over into the flask and

there condenses, forming a yellow cloud of solid particles which collect on the sides of the flask, forming a layer of "flowers of sulphur."

It is known that ice and snow evaporate at temperatures below the freezing point. Snow often disappears completely by evaporation on very cold days, when no trace of thawing can be detected.

✓ THE LATENT HEAT OF VAPORISATION.

158. When water is boiled it has been shown that the temperature of the steam produced is the same as that of the boiling water. Where then has the heat given to the water by the burning gas gone? On comparing this process with that observed when ice melts it is evident that the heat has been used up in effecting the change of state from liquid to vapour, *i.e.* the heat has been rendered "latent," to use the same word as we have used before.

This heat is given out in the process of condensation of steam to water, as is shown in the following experiment.

Exp. 120. Place about 250 c.c. of cold water in a beaker, insert a thermometer, and weigh the whole. Now boil some water in a flask fitted with a delivery tube, and pass the steam given off into the water in the beaker.

As the bubbles of steam enter the cold water they condense with a crackling sound and the temperature of the water rises rapidly. By weighing the beaker we ascertain the weight of the steam condensed.

This does not by itself prove that steam gives out heat in *condensing*. When the steam enters the cold water we may consider that the following changes take place:—

- (1) It condenses into boiling water without change of temperature.
- (2) This boiling water mixes with the cold water in the beaker.

Hence, if steam gives out heat in condensing simply, the rise of temperature produced by passing the steam into the cold water should be greater than that produced by mixing the same quantity of boiling water with the cold water.

If now we take the same quantity of water in the same beaker and add to it a quantity of boiling water equal to that obtained by the condensation of the steam, it will be found that this gives a much smaller rise of temperature. This shows that the steam, in condensing from steam to boiling water without fall of temperature, gives out a considerable quantity of heat.

159. Latent heat of vaporisation. It is found that a given liquid absorbs, per unit mass, during vaporisation and evolves, per unit mass, during condensation a definite quantity of heat which is constant for the same substance under the same conditions. The quantity of heat required to convert *unit mass of a substance* from the liquid state at the boiling point to the vapour state at the same temperature is called the **latent heat of vaporisation** of that substance. Thus the latent heat of vaporisation of water at 100°C . is the quantity of heat required to convert unit mass of water at 100°C . into steam at 100°C . It is also the quantity of heat given out by unit mass of steam at 100°C . in condensing to unit mass of water at 100°C . If the *gramme* be taken as the unit of mass, then the latent heat should be expressed in *gramme degrees*; that is, the same unit of mass should be involved in both measurements.

It follows that if L denotes the latent heat of vaporisation of any substance, then the quantity of heat absorbed during vaporisation or evolved during condensation by M grammes of the substance is ML units.

It is to be noted that the latent heat of vaporisation of any substance depends upon the temperature at which vaporisation takes place. If the conditions of vaporisation change the boiling point it is to be expected that the latent heat of vaporisation will also change.

Exp. 121. Find roughly the latent heat of vaporisation of steam.

Method I. (No thermometer is required.) Place in a tin can a mixture of ice (one part by weight) and cold water (about four parts by weight). Arrange a Bunsen burner under a tripod, keep it burning steadily throughout the experiment. When all the ice in the mixture has melted note the time and at once place the can over the Bunsen flame. Note also the time when (ii) boiling begins, (iii) the water has just boiled away.

Method II. (A thermometer is required.) Put a tin can, half filled with water, over a Bunsen burner burning steadily. Note the time when (i) the temperature is, say, 25°C ., (ii) boiling begins, (iii) the water has just boiled away.

Calculation. Assume that the heat absorbed from the flame by the water is proportional to the time during which it has been heated. Find (i) the time, T , taken to boil away the whole of the water, (ii) the time, t , taken to warm the water from ice-point to boiling. In Method I. the initial temperature is the ice-point; in

Method II. it is, say, 25°C . In the latter case calculate the whole time it would have taken to heat the water from 0°C . to 100°C . if the initial temperature had been 0°C . Finally

$$\frac{\text{“Latent heat” absorbed in vaporisation}}{\text{“Sensible heat” absorbed from ice- to steam-point}} = \frac{T}{t}.$$

Example. Time taken to heat a quantity of water from 25°C . to $100^{\circ} = 3$ min. 30 sec. = 210 sec. Time taken to boil away the water = 23 min. 40 sec. = 1420 sec. Then the time taken to heat the water from 0°C . to 100°C . would have been $\frac{2}{3} \times 210 = 280$ sec. Therefore (latent heat) / (sensible heat) = $1420/280 = 5.1$, i.e. the latent heat of vaporisation of water = 510 calories per gm.

160. Determination of the latent heat of steam. The latent heat of vaporisation of water at 100°C . is usually called the latent heat of steam. To determine this constant a calorimeter is prepared in the usual way by placing in it a known quantity of water at a known (low) temperature. A current of *dry* steam from a boiler is then passed either directly or into a worm immersed in the water in the calorimeter. The steam condenses, gives out its latent heat and the temperature of the water rises. When a sufficient rise of temperature is produced the current of steam is stopped and the temperature of the water in the calorimeter noted. The calorimeter is then weighed and the increase of weight gives the mass of the steam condensed.

Denoting the masses of the cold water, calorimeter, and condensed steam by m , m_1 , M respectively, and the initial temperature of the steam and the initial and final temperatures of the water by T , t , θ , the latent heat of vaporisation of water by L , and the specific heat of the material of the calorimeter by s_1 , we have, by equating the heat given out by the steam and its resultant water to the heat absorbed by the calorimeter and its contents,

$$ML + M(T - \theta) = (m + m_1s_1)(\theta - t),$$

from which

$$L = \frac{(m + m_1s_1)(\theta - t)}{M} - (100 - T).$$

As the experiment lasts only a few seconds, the rise of temperature being very rapid, the cooling correction is not of great importance, but it is well to arrange that the mean

temperature of the calorimeter is the same as the temperature of its surroundings. The great difficulty and a great source of error in this experiment is the difficulty of ensuring that the steam which enters the calorimeter is *dry*. It is obvious that if the steam carries with it a fine spray of condensed water the heat evolved in the calorimeter will be much less than if only dry steam entered the calorimeter, and the value of L obtained will be too low. Various devices for "trapping" or jacketing the current of steam have been adopted for the purpose of *drying* it; that is, removing the fine drops of condensed water in it.

Exp. 122. *Find the latent heat of vaporisation of water.*
—Fig. 119 shows a useful form of apparatus. Water is boiled in a tin can F , and the steam is led out by a bent

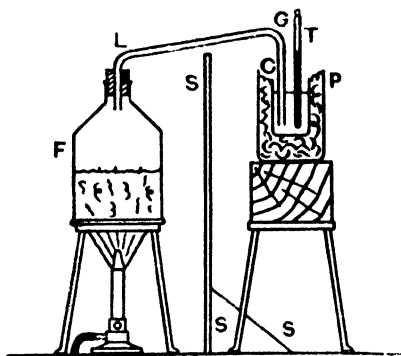

Fig. 119.

glass tube LG (which may be covered by cotton-wool) into the calorimeter C , which may be hung inside the screening can P or packed lightly inside it by means of cotton-wool. SS is a screen which prevents heat passing directly from the boiler to the calorimeter part of the apparatus.

Boil the water in F briskly (F should be less than half full or the steam will carry spray with it). Weigh the calorimeter empty and again when two-thirds full of water. Use a sensitive thermometer: carefully stir the water with it and note the temperature.

It is advisable to have the initial temperature of the water as much below the air temperature as the final temperature is above it. This obviates any correction for gain of heat from outside sources or loss of heat to them. A preliminary experiment will supply the best temperature at which to work.

When placing the calorimeter in position see that the end of the glass tube is well immersed.

The issuing steam condenses with a kind of continuous hiss.

Stir gently with the thermometer. The temperature rises rapidly. Withdraw the calorimeter from the jet when the temperature has reached, say, 35°C . Stir well. Quickly note the temperature. Remove the thermometer from the water, letting its bulb trail along the inside (above the water) of the calorimeter, so that any drops of water adhering to the thermometer may be removed from it. Weigh. The increase over the last weighing gives the weight of steam condensed. Assume that the temperature of steam is 100°C ., and work out the results as indicated above.

Example.—*Determine the latent heat of vaporisation of water from the following observations:—*

Mass of copper calorimeter = 52.94 gm. , mass of calorimeter plus water = 192.14 gm. , mass of calorimeter plus water plus condensed steam = 197.12 gm.

Temperature of steam 100°C ., of cold water at the beginning of the experiment 14.4°C ., of water finally 35.1°C . Air temperature 21°C .

The heat given out

- (1) by the 4.98 gm. of steam at 100°C . condensing to water at 100°C . = 4.98 L calories ,
- (2) by the 4.98 gm. of water cooling from 100°C . to 35.1°C .
= $4.98(100 - 35.1) = 4.98 \times 64.9\text{ calories}$.

The heat absorbed

- (1) by the 139.2 gm. of water in rising from 14.4°C . to 35.1°C .
= $139.2 \times 20.7\text{ calories}$.
- (2) by the 52.94 gm. of copper in rising from 14.4°C . to 35.1°C .
= $52.94 \times .095 \times 20.7 = 5.03 \times 20.7$.

Equating the heat given out to the heat absorbed we get

$$4.98\text{ L} + 4.98 \times 64.9 = (139.2 + 5.03) \times 20.7.$$

$$\therefore \text{L} = \frac{144.2 \times 20.7}{4.98} - 64.9 = 535\text{ calories.}$$

The chief source of error in the method described above is that the steam is not dry when it enters the calorimeter.

It carries spray with it. Sometimes a water-trap, like that shown in Fig. 120, is placed at the delivery end of the steam tube. It catches the water that condenses in the tube. It should be very well wrapped up in cotton-wool and provided with a jet and pinch-cock, R, to allow the condensed water to be drawn off from time to time.



Fig. 120.

161. Berthelot's apparatus for finding the latent heat of vaporisation. In order to get rid of the error mentioned in the last paragraph Berthelot devised the apparatus shown in Fig. 121, which can be used for any liquid.

The liquid in K is boiled by means of a ring burner *U*, the water in the calorimeter is screened from radiation from

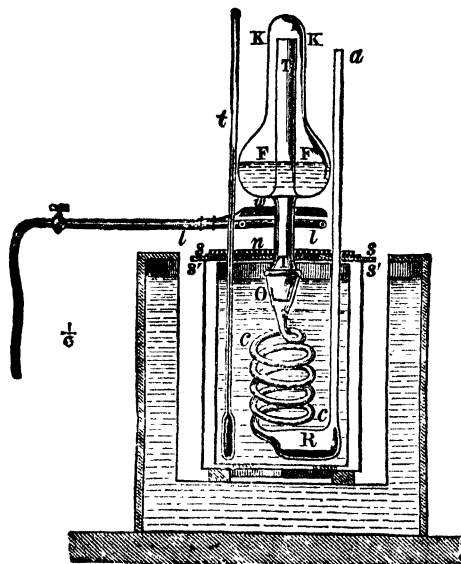

Fig. 121.

the burner by means of two screens *ss*, *s's'*, and from other external radiation by a copper vessel and a double-walled vessel filled with water. The vapour generated in the

vessel K passes down through the short tube T T into the spiral tube or worm C C A immersed in the water in the calorimeter.

The only part of the vapour tube in which condensation is possible outside the calorimeter is in the short piece of tube surrounded by the burner. The error arising from partial condensation before the vapour enters the calorimeter is thus reduced to a minimum. The method is quick, about 20 gm. of liquid being condensed in 3 minutes. It is also very convenient for the study of the latent heats of vaporisation of organic liquids, as the condensed liquid is caught in the reservoir R and does not mix with the water. The increase of weight of the worm gives the weight of the vapour condensed; the calculation is similar to that in the case of water.

By this method Berthelot obtained 536.2 for the latent heat of vaporisation of water at 100° C. By a much more elaborate method Regnault obtained 536.5. More recent work shows that the latent heat of vaporisation at 100° C. is 540 calories per gramme, *i.e.* one gramme of steam at 100° C. in condensing to water at 100° C. gives out 540 calories, or one gramme of water at 100° C. absorbs 540 calories in becoming steam at 100° C.

Exp. 123.—*Find the latent heat of vaporisation of water by a modification of Berthelot's method.* Set up the apparatus shown in Fig. 122. Half fill the flask with water, and fit it with a cork and tube *tt*. Invert and heat by a simple ring burner B. Attach a nozzle *n* to the tube *t* by a piece of rubber tubing *i*. The calorimeter C is supported within a screen and shielded from the burner by a block of wood. To perform the experiment allow steam to pass from *n* for some time and then quickly lift C into position. When the temperature has risen sufficiently remove C and note the maximum temperature reached. The calculations are as before.

The large expansion which occurs when water is turned into steam (Art. 147) accounts in some degree for the large latent heat of vaporisation, for during the change of state the rising vapour does work in pushing away the atmosphere, and, as shown later in Ch. XVI., heat and work are mutually convertible.

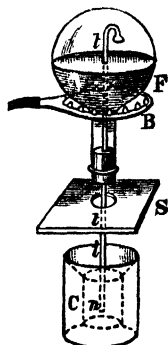

Fig. 122.

162. **Regnault's results in connection with the latent heat and total heat of steam.** Regnault investigated the question of latent heat of steam in a series of careful and elaborate experiments, and found that its value depends upon the temperature at which vaporisation takes place. The real aim of his experiments was, however, to find the **total heat of steam**, *i.e.* the amount of heat required to raise one gramme of water from 0°C. to $T^{\circ}\text{C.}$ and to vaporise it at that temperature, the pressure at the time of vaporisation being the maximum pressure of vapour water at $T^{\circ}\text{C.}$

From the data of a large number of experiments he was able to formulate his results thus: If Q_T denote the total heat required to raise unit mass of water from 0°C. to $T^{\circ}\text{C.}$, and also to convert it into steam at $T^{\circ}\text{C.}$, then—

$$Q_T = 606.5 + 0.305T. \quad (1)$$

But since, approximately, T units are absorbed by the water in being raised from 0°C. to $T^{\circ}\text{C.}$, we have—

$$Q_T = L_T + T,$$

where L_T is the latent heat of vaporisation at $T^{\circ}\text{C.}$

Thus we have—

$$L_T = Q_T - T;$$

or—

$$\begin{aligned} L_T &= 606.5 + 0.305T - T, \\ &= 606.5 - 0.695T. \end{aligned} \quad (2)$$

To calculate the total heat required to raise unit mass of water from 0°C. to 100°C. , and to convert it into steam at 100° , substitute 100 for T in equation (1), and we get—

$$\begin{aligned} Q_{100} &= 606.5 + (0.305) 100 \\ &= 637. \end{aligned}$$

Similarly—

$$\begin{aligned} L_{100} &= 606.5 - 69.5 \\ &= 537. \end{aligned}$$

These formulae for Q and L indicate the general result that **Q increases while L decreases with rise of temperature.**

We have hitherto spoken only of the variation of L with temperature, but it is evident that this implies variation with pressure; for, when we speak of the latent heat of vaporisation of water at $T^{\circ}\text{C.}$, we imply that vaporisation takes place at a pressure equal to the maximum pressure of water vapour at $T^{\circ}\text{C.}$

The results of Regnault's work may be illustrated graphically. Assuming that the formula

$$L_T = 606.5 - 0.695T$$

holds between 0°C. and 200°C. , we have—

$L_0 = 606.5$	$Q_0 = 606.5$
$L_{40} = 578.7$	$Q_{40} = 618.7$
$L_{80} = 550.9$	$Q_{80} = 630.9$
$L_{120} = 523.1$	$Q_{120} = 643.1$
$L_{160} = 495.3$	$Q_{160} = 655.3$
$L_{200} = 467.5$	$Q_{200} = 667.5$

From these figures the dotted lines shown in Fig. 123 have been plotted. They are straight lines, *i.e.* the changes of L and Q with

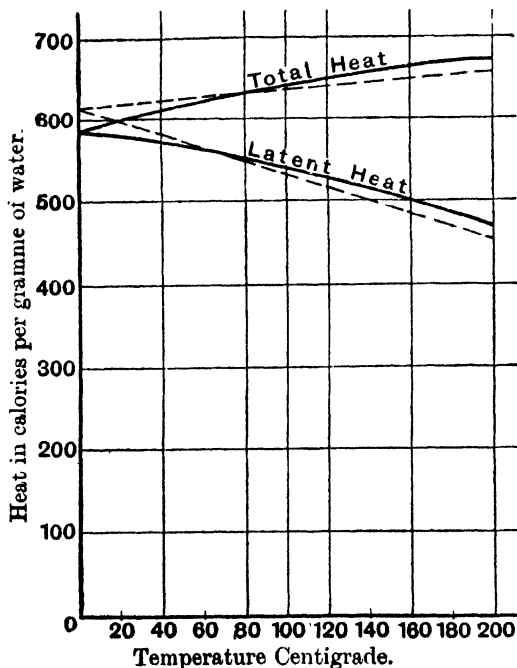

Fig. 123.

temperature are linear. From them the latent heat or total heat for any temperature within the range of the diagram can be read easily.

Recent work has shown that $L_{100} = 540$, and not 537.5 as deduced by Regnault. In calculating L from Q Regnault also neglected the variation in the specific heat of water (Art. 100). The values of Q and L have recently been recalculated by Callendar, and his results are shown by the full curves of Fig. 123. These curves are not straight lines, and no simple equation can be obtained connecting Q and L with T .

TABLE OF LATENT HEATS OF VAPORISATION.*

At boiling point under a pressure of 760 mm. mercury at 0° C.

Water	540
Sulphur	362
Alcohol	202
Ether	90
Oil of turpentine	74
Liquid air	55

Water differs from most other substances in having a very high latent heat for both changes (refer to the table on p. 185).

163. Steam calorimeter. The latent heat of steam may be applied, just as the latent heat of water is applied in the ice calorimeters, to ascertain the specific heat of a substance.

The invention and perfection of the steam calorimeter is due to Professor Joly. The general principle applied in a steam calorimeter is as follows:—If a piece of any substance at a known temperature is suspended in an empty vessel and steam at 100° C. is passed into the vessel, a mass of steam just sufficient to raise the temperature to 100° C. will condense on the substance, and this mass will remain constant so long as the substance remains in the atmosphere of steam. Loss by the dropping of the condensed water from the substance must of course be guarded against. Hence, if the mass of water which condenses on the substance can be determined, the specific heat of the substance can be calculated.

Thus if m is the mass of the substance, s its specific heat, t its original temperature, M the mass of steam

* The latent heat decreases as the temperature of boiling rises,

condensed, T its temperature, and L the latent heat at this temperature, we have—

$$\text{Heat absorbed by the substance} = m s (T - t),$$

$$\text{Heat given out by the steam} = M L,$$

$$\therefore m s (T - t) = M L,$$

whence

$$s = \frac{M L}{m (T - t)}.$$

In its simplest form the steam calorimeter consists essentially of a thin metal vessel which can be quickly filled with dry saturated steam from a boiler which communicates with this steam chamber by a wide tube fitted with a suitable stopcock, by means of which the supply of steam may be regulated or stopped as desired. A small platinum scale-pan suspended by a thin wire from one arm of a balance hangs freely in this steam chamber. A piece of the substance of which the specific heat is required is placed in this pan and carefully weighed, when the chamber is filled with air only.

Steam is then turned on, and the steam, in raising the scale-pan and body on it to its own temperature, condenses to water at the same temperature. This water remains on the pan and body, and when the final temperature is reached remains constant in quantity for as long as may be desired. The increase in weight, due to this condensation, can be determined accurately by means of the balance, proper corrections being made for the buoyancy of air in the first weighing, and of steam in the last.

164. Joly's steam calorimeter (Fig. 124) shows the form of steam calorimeter first used by Dr. J. Joly. The bent tube, marked with the arrows, is the steam tube bringing the steam to the calorimeter from the boiler, which is not shown. The suspension wire from the balance enters the calorimeter by passing through a small hole in the centre of a smooth flat disc which rests on the tubular opening at the top of the calorimeter. The surface of the disc fits accurately to the surface of the edge of the tube on which it rests and so closes the calorimeter; at the same time it moves freely in a horizontal plane so that the central hole

readily adjusts its position to that of the suspension wire. A small quantity of steam escapes between the wire and the edge of the hole in the disc; this is prevented from condensing on the wire by surrounding the wire just above the hole with a spiral of platinum wire which is heated by passing a current through it.

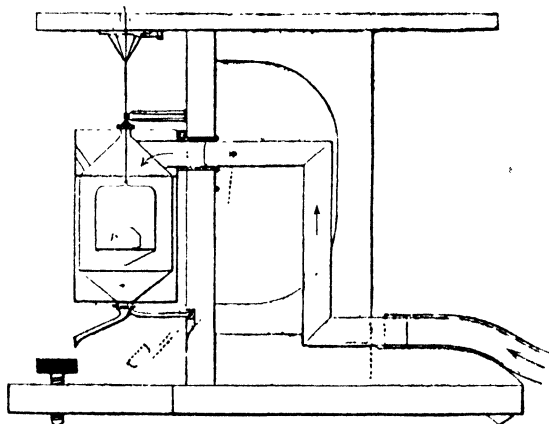

Fig. 124.

The necessary correction for the weight of water condensed on the platinum scale-pan may be obtained by a preliminary experiment with the pan only. If c denote the water equivalent of the pan the heat equation given above may be modified to include the scale-pan and written as follows:—

$$(ms + c)(T - t) = ML.$$

With a properly constructed calorimeter the results obtained by this condensation method may attain a very high degree of accuracy. One important source of error is the possible fall of very small drops of condensed water on the substance and pan carrying it, when the steam is first introduced into the cold calorimeter. This error is made practically negligible by admitting the steam suddenly into the chamber, and it is for this purpose that the steam

pipe is made wide. After the first sudden admission the supply should be regulated so as to provide a gentle current of steam which will not interfere with the process of weighing.

Exp. 124. Find the specific heat of a substance by Joly's steam calorimeter. Fit up a simple steam chamber as shown in Fig. 125. It consists of a beaker, B, fitted with a wooden cover or large flat cork, C, provided with delivery and exit tubes, I and O, and a small central hole, H, through which a thin wire, V (preferably of platinum), descends from the balance. The central hole should be covered with a thin aluminium disc, D, as described above. The pan, P, may be of platinum or copper, and should be heavy enough when empty to keep the wire quite taut. The beaker, B, is placed with a loose cotton-wool packing, W, inside a larger jar, J.

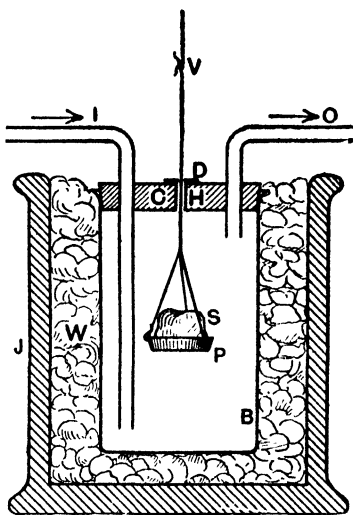

Fig. 125.

First find the constant of the empty pan as described above. Take the temperature and pass the steam.

After 4 or 5 minutes the pan ceases to increase sensibly in weight, and the equilibrium of the balance is maintained very nearly permanent. If the aluminium disc moves freely, it will adjust its position so that the wire, V, always passes freely through the hole in the disc. Care should be taken that water is not deposited on the wire and in the hole. Note the increase of weight,* and then

* For accurate result the difference in weights should be corrected in the first case for the buoyancy of air and in the second for the buoyancy of steam.

shut off the steam. The calculations are performed as under. When the beaker is cold, clean and dry the pan, put on a lump, S, of the substance and repeat the experiment. Repeat two or three times until the results are in close agreement.

Example. (1) Find the constant of the pan of a Joly's steam calorimeter from the following readings :—

Initial temperature 13°C ., temperature of steam 101°C ., increase of weight of pan = $\cdot 252$ gm.

If c = water equivalent of the pan,

$$c \times (101 - 13) = \cdot 252 \times 540,$$

$$\therefore c = \frac{\cdot 252 \times 540}{88} = 1\cdot 55 \text{ gm.}$$

(2) A lump of quartz was placed on the above pan and the experiment repeated. Mass of quartz $16\cdot 73$ gm., initial temperature $15\cdot 2^{\circ}\text{C}$., temperature of steam $100\cdot 5^{\circ}\text{C}$., increase of weight of pan $\cdot 7420$ gm. Find the sp. ht. of quartz.

We have

$$(16\cdot 73 s + 1\cdot 55)(100\cdot 5 - 15\cdot 2) = \cdot 7420 \times 540.$$

$$\therefore 16\cdot 73 s = \frac{\cdot 7420 \times 540}{85\cdot 3} - 1\cdot 55 = 4\cdot 70 - 1\cdot 55 = 3\cdot 15.$$

$$\therefore s = \cdot 188.$$

Exp. 125. Find the specific heats of glass and aniline by the steam calorimeter. First make a glass bulb, not too large to rest on the pan and yet sufficient to hold about 5 gm. of liquid. Find the specific heat of the bulb as described above. Repeat till the results agree. Then fill the bulb with aniline, seal the top, replace on the pan and repeat the experiment. The calculations are as before. Repeat till, with practice, the results agree.

165. The specific heats of gases. Dr. Joly employed an improved form of this calorimeter to determine the specific heat of gases at constant volume. In the improved form, known as the differential steam calorimeter, two exactly similar pans hang one from each arm of the balance in a large steam chamber. If the two pans are exactly alike and have the same water equivalent, it is evident that they will counterpoise each other throughout an experiment, and the corrections for buoyancy, water equivalent of pan, and in fact all corrections necessary for symmetrical sources of error in the calorimeter become unnecessary.

Figure 126, reduced from Dr. Joly's paper, shows the front and end views of the differential steam calorimeter as used for determining the specific heat of gases at constant volumes.

The gas experimented on was placed in two exactly similar spherical shells of copper made strong enough to stand a pressure of between 30 and 40 atmospheres. One

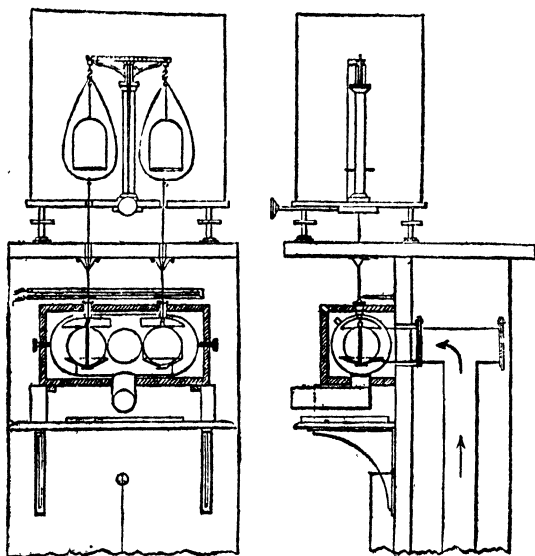

Fig. 126.

shell contained the gas at a pressure of about 20 atmospheres, and in the other the pressure was reduced practically to a vacuum. These shells, with small "catchwaters" attached to them, took the place of the platinum scale-pans, and were suspended from the arms of the balance in the steam chamber, and carefully balanced at a known temperature. Steam was then admitted in the usual way and a balance again obtained.

It is evident that under these conditions the excess of water which condenses on the shell containing the gas at

high pressure is that which in condensing to water gives out the heat required to raise the excess of air in this shell through the known range of temperature. In this way the specific heat of air and other gases at constant volume has been directly determined.

For very accurate work correction has to be made on account of the change of volume of the shell due to heating and pressure, but the errors due to these causes are small.

The experiments confirm the result obtained for air by the method of Art. 245, last paragraph. They also show that the specific heat at constant volume for air and carbonic acid gas increases with pressure—thus, at about 7 atmospheres pressure the specific heat of carbonic acid gas is $\cdot 168$, at 22 atmospheres it is about $\cdot 174$, and for air the specific heat at 20 atmospheres pressure is about $\cdot 173$. The specific heat of hydrogen at atmospheric pressure was found to be about $2\cdot 4$, and apparently decreases with increase of pressure.

EXERCISES XI.

1. A flask containing water is heated. When the water boils, the flask is carefully closed with a cork and removed from the flame. Explain why, when the flask is dipped into cold water, the water inside begins to boil again.

2. The temperature of a room the doors and windows of which had been kept shut for some time was 80° F. Some water (also at 80°) was sprinkled over the floor, and the temperature at once fell several degrees. Explain this.

3. The boiling point of water on the top of a mountain is found to be $89\cdot 0^{\circ}$ C. What would be the height of a barometer there? Express the pressure in dynes per sq. cm. (Take $g = 980$.)

4. A glass bottle and a bottle of porous earthenware are both filled with water and exposed to the air side by side. Usually, the water in the earthenware bottle becomes decidedly colder than that in the glass; why is this? If there is little or no difference of temperature, what conclusion may we draw as to the state of the atmosphere? and why?

5. If the maximum pressure of water vapour is 758 mm. at $99\cdot 93^{\circ}$ C. and 759 mm. at $99\cdot 96^{\circ}$ C., what increase in size takes place in a bubble of air just under the surface of some water as the temperature rises from $99\cdot 93$ to $99\cdot 96$, supposing the pressure of the

CHAPTER XII.

HYGROMETRY.*

FORMATION OF CLOUDS, FOG, AND DEW. METEOROLOGY.

166. Water vapour in the air. Evaporation is constantly going on from the surface of the sea, rivers, and lakes. There must therefore always be some water vapour in the air. This water vapour when quite free from small particles of condensed water is invisible, but we may convince ourselves of its presence by one or two simple experiments.

Exp. 126. Fit a flask with a delivery tube, as shown in Fig. 127, and boil some water in it. A steady current of water vapour obviously issues from the delivery tube and mixes with the air in the room. Water vapour must therefore be diffused throughout the air in the room, although, with the exception of the small cloud of condensed vapour at the mouth of the tube, there is no visible sign of its presence.

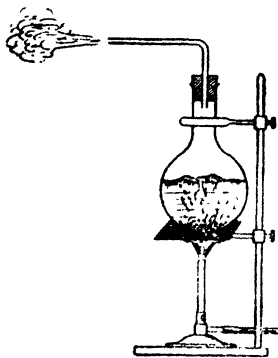

Fig. 127.

Note in this experiment (a) the *dry* water vapour in the flask and in the tube is invisible, (b) the jet of steam issuing from the tube is invisible until it is condensed by contact with the colder air to form the small cloud which appears at a *short distance* from the mouth of the tube, (c) the cloud consists of minute drops of water, (d) the water drops of the cloud quickly evaporate and the vapour diffuses throughout the air in the room.

* Gr. *hygros*, wet ; *metron*, a measure.

Exp. 127. Fill a glass vessel full of cold water and after thoroughly drying the outer surface of the vessel bring it into a "living room" or into a room where the preceding experiment is going on. Beads of moisture, resulting from the condensation of the vapour in the air, will quickly form on the surface of the cold glass.

167. Relative humidity. We speak of the air as being *dry* or *moist* according as we think it contains little or much moisture, but the condition of the air, in relation to dryness or moisture, involves two elements: (1) the quantity of vapour *actually present* in the air, (2) the quantity of vapour necessary to *saturate* the air under the same conditions; and it is on the *ratio* of these two elements that our sensations of dryness and moisture chiefly depend, and not on the first alone. Thus, the air in a warm room may really contain more aqueous vapour than the outside air and yet be *drier* because the amount required to saturate it is so much greater; for we have seen that the mass of vapour required to saturate a given space increases with the temperature, and is independent of the presence of air or other gas in that space.

The hygrometric state of the air, considered as the ratio of the mass of aqueous vapour actually present in a given volume to the mass of vapour required to saturate the same volume, at the same temperature, is called the **humidity** or **relative humidity** of the air.

The relative humidity is usually expressed either as a ratio or as a percentage.

Example. If a cubic metre of air at a particular temperature contains 10 gm. of aqueous vapour, and if 30 gm. are required to saturate it at the same temperature, the relative humidity is $\frac{1}{3}$, or 33 per cent.

168. Determination of relative humidity by the absorption method. If we can find by actual experiment the mass of vapour really present in a given volume of air, and also calculate the mass of vapour required to saturate the same volume at the same temperature, we can at once find the relative humidity of the air. For this purpose a quantity of the air is drawn through a series of drying tubes containing fragments of pumice-stone soaked in concentrated

sulphuric acid. To effect this the drying tubes are connected together by short communicating tubes, and one end of the series is connected to the upper tube of an aspirator,* while the other opens into the outer air. The aspirator is filled with water, and, when the communication with the drying tubes is effected, the upper and lower stopcocks are opened. The water then flows out by the lower tube, and air is sucked in through the drying tubes and is collected in the upper part of the aspirator.

The air, in passing through the drying tubes, is deprived of its moisture, and by determining the increase in weight of the first two or three tubes, the weight of moisture deposited is known. The volume of the air drawn through the apparatus is determined by the weight of the water which has escaped from the aspirator.† This volume being determined, it only remains to calculate, from Regnault's tables (p. 273), the mass of vapour necessary to saturate it at its initial temperature, and then deduce the relative humidity from the ratio—

$$\frac{\text{Quantity of vapour actually present in the given volume}}{\text{Quantity of vapour that would saturate this volume at the existent temperature}}$$

Exp. 128. *Measure the amount of water vapour in the atmosphere and deduce the relative humidity.* Set up the apparatus and perform the experiment as described above. Consult Regnault's tables and deduce the relative humidity.

Instead of consulting Regnault's tables a direct determination may be made of the quantity of water required to saturate a given volume of air.

Exp. 129. Attach to the inlet of the drying tubes a long glass tube ($1\frac{1}{2}$ " bore) containing crushed pumice-stone moistened with water. The air is now saturated by the time it gets to the drying tubes. To remove any drops of water mechanically carried by the

* The aspirator, A, Fig 128, is a large vessel of from 5 to 10 litres capacity, having a tube fitted with a stopcock at its upper and lower ends.

† If great accuracy is required this volume must be corrected for the temperature of the water in the aspirator and the aqueous vapour present. (See Art. 176.)

stream of air insert a tube packed with cotton-wool between the saturating tube and the drying tubes. The drying tubes thus record the mass of vapour required to saturate air at its temperature when leaving the long tube. To measure the temperature insert a thermometer in the long tube, with its bulb just opposite the connecting tube to the drying tubes. Since the temperatures of the air in the two experiments are not likely to be the same a slight temperature correction is necessary.

Exps. 128 and 129 can be made into one experiment by putting all the tubes in "series." The air must first go through the tubes of Exp. 128 and then through the "saturator" and the tubes of Exp. 129. In this case the volume of air passing through the tubes need not be measured and the suction of air can conveniently be arranged by joining up the tubes to a water-pump working gently. The tubes can then be left for any time.

169. Dew-point. Under ordinary circumstances the quantity of water vapour present in the air is not enough to produce saturation, and the pressure due to the vapour present is therefore less than the maximum vapour pressure for the temperature of the air. If, however, the air be gradually cooled a temperature is soon reached at which the amount of vapour actually present is sufficient to produce saturation. This temperature is called the **dew-point**. At the dew-point the air is saturated with the vapour present, and the pressure due to the vapour is therefore the maximum vapour pressure at that temperature.

When the air is cooled below the dew-point condensation begins at the dew-point, and as the temperature falls the excess of vapour over the amount necessary to give saturation at any temperature condenses out. If the air is cooled by contact with the surface of a cold body the layer of air in contact with the surface quickly reaches the dew-point, and a film of condensed moisture or dew is deposited on the cooling surface (see Exp. 127). If, however, the air is cooled, as a whole or in part, without being in contact with a cooling surface on which the condensed moisture may be deposited, a slight cloud or

fog of minute drops of condensed water may form in the cooled air or (under favourable conditions) there may be supersaturation.

170. Determination of relative humidity from a knowledge of the dew-point. The absorption method described in Art. 168 leaves nothing to be desired so far as accuracy is concerned, but it is a somewhat tedious and difficult process; and, as it is very often necessary, for meteorological and other purposes, to know the hygrometric state of the air at the actual instant considered, and not the mean hygrometric state during, say, an hour, simpler methods based upon the determination of the *dew-point* have been adopted.

Since water vapour approximately obeys Boyle's law even up to saturation, the mass of water present, per unit volume, is proportional (approximately) to the pressure it exerts. And this is the saturation pressure at the dew-point. We may therefore adopt the following as an alternative definition of relative humidity:—

The *relative humidity* of the air at a given instant is equal to the ratio of the maximum vapour pressure at the temperature of the dew-point to the maximum vapour pressure at the actual temperature of the air.

If m = mass of water vapour actually present in the air,

M = mass of water vapour necessary to saturate the air under the existing conditions,

f = maximum pressure of water vapour at the dew-point,

F = maximum pressure of water vapour at the temperature of the air,

then the relative humidity = $\frac{m}{M} = \frac{f}{F}$.

Tables such as the following have been drawn up showing the maximum pressure of aqueous vapour and the mass of vapour present in a given volume of air for various temperatures. It will be seen that the numbers in the two columns (under f and m) are very nearly proportional to each other. They are not quite proportional, for unsaturated vapours only approximately obey the gaseous laws. The proportionality is, however, sufficiently close for all practical purposes.

TABLE SHOWING PRESSURE OF AQUEOUS VAPOUR (*f*) IN MM. OF MERCURY, AND MASS OF WATER (*m*) IN GRAMMES CONTAINED IN 1 CUBIC METRE OF AIR, WITH DEW-POINT (*t*).—(Regnault and Magnus.)

<i>t</i>	<i>f</i>	<i>m</i>	<i>t</i>	<i>f</i>	<i>m</i>	<i>t</i>	<i>f</i>	<i>m</i>	<i>t</i>	<i>f</i>	<i>m</i>
C.	mm.	gms.	C.	mm.	gms.	C.	mm.	gms.	C.	mm.	gms.
- 10°	2·0	2·1	0°	4·6	4·9	10°	9·1	9·4	20°	17·4	17·2
- 9	2·2	2·4	1	4·9	5·2	11	9·8	10·0	21	18·5	18·2
- 8	2·4	2·7	2	5·3	5·6	12	10·4	10·6	22	19·7	19·3
- 7	2·6	3·0	3	5·7	6·0	13	11·1	11·3	23	20·9	20·4
- 6	2·8	3·2	4	6·1	6·4	14	11·9	12·0	24	22·2	21·5
- 5	3·1	3·5	5	6·5	6·8	15	12·7	12·8	25	23·6	22·9
- 4	3·3	3·8	6	7·0	7·3	16	13·5	13·6	26	25·0	24·2
- 3	3·6	4·1	7	7·5	7·7	17	14·4	14·5	27	26·5	25·6
- 2	3·9	4·4	8	8·0	8·1	18	15·4	15·4	28	28·1	27·0
- 1	4·2	4·6	9	8·5	8·8	19	16·3	16·2	29	29·8	28·6
- 0	4·6	4·9	10	9·1	9·4	20	17·4	17·2	30	31·6	30·1

Exp. 130. Determine the dew-point and calculate the relative humidity of the air. Half fill a thin glass (plain ruby or green) with water from the tap. Add small pieces of ice, stir with the thermometer and note the temperature when a deposit of moisture begins to show on the glass. This is the dew-point. Check it by withdrawing the ice and allowing the temperature to rise, noting the temperature at which the last traces of dew vanish. Take the mean of the two readings as the dew-point. Dry the thermometer and note the temperature of the air. Look up in the table the saturation pressures at these temperatures and calculate the relative humidity.

Thus if the dew-point is 10° C. and the air temperature is 15° C., the relative humidity

$$= \frac{\text{maximum pressure of water vapour at } 10^{\circ} \text{ C.}}{\text{maximum pressure of water vapour at } 15^{\circ} \text{ C.}} = \frac{9\cdot1}{12\cdot7} = \cdot72,$$

or 72 per cent.

171. Dew-point hygrometers. These are instruments devised for determining the dew-point, and thus, as explained above, indicating the hygrometric state of the air; they assume somewhat different forms, but the principle of action is the same in each. The more important forms are given below:—

172. Regnault's hygrometer. This consists (Fig. 128) of a glass tube, T, closed below by a thin silver cap, S. Its mouth is fitted with a cork carrying a thermometer, *t*, and a piece of tubing, *d*, both passing down nearly to the bottom of the tube. To use the instrument ether is placed in the

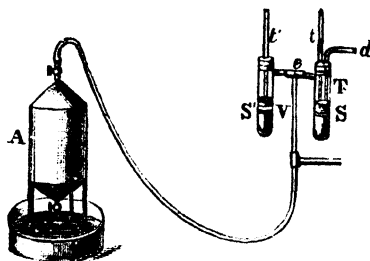

Fig. 128.

tube, and a current of air is drawn through by the aspirator, A*; entering by *d*, the air bubbles through the liquid and enters A after passing through the side tube *e* and the vertical tube V. This passage of air through the ether in S causes rapid evaporation to take place; the temperature of the liquid therefore falls, and ultimately the aqueous vapour in the air condenses on the surface of S. The temperature is then read. This will be below the dew-point, as no dew is seen till a perceptible quantity has formed. The aspirator is now shut off; the temperature of S rises, and when the last trace of dew vanishes the temperature is again read. The mean of the readings is the dew-point.

By regulating the current of air the cooling of the liquid in S may be made sufficiently slow to note, with accuracy, the temperature at which the film of moisture commences to form on S. This observation is usually further facilitated by having a second tube, S', similar to the hygrometer

* The aspirator should in practice be placed a considerable distance away from the hygrometer, so that the water in the pan may not alter the hygrometric state of the air near the hygrometer.

tube, supported on the same stand, in such a position that the appearance of the two silver caps may be easily contrasted, and the dimness due to the deposition of moisture on S more readily detected. S' is not, however, an essential part of the instrument: it has no connection with S or V,* and serves only for comparison, as explained above, and to carry a thermometer, *t'*, which gives the temperature of the air.

In order to obtain good determinations with any form of dew-point hygrometer, the experiment should be repeated until the temperatures of appearance and disappearance of the film of moisture on the cold surface are very nearly the same, say within 0.5° C. of each other. The observations should be made by means of a telescope at some distance from the apparatus, so that all risk of error due to the proximity of the observer is obviated. If a telescope is not available the observer should place a large sheet of glass between himself and the instrument. If a fine wire is drawn over the surface of the bulb it is easy to detect the first traces of moisture.

173. Dines's hygrometer. This is a simple and convenient form of hygrometer (Fig. 129). R is a small reservoir which communicates, by means of a tube *t*, with the lower compartment of

a small double chamber C; in the upper compartment is placed the bulb of a thermometer. The stem of the thermometer is visible from above through a narrow groove cut in the stand, and the chamber C is roofed over by a piece of thin black glass *gg*, on which the slightest film of moisture is easily perceived. To determine the dew-point



Fig. 129.

cold water, containing ice if necessary, is put in R and a slow stream allowed to flow through C, around the thermometer, under the black glass, and out at *d*. The glass

* The side tube shown is sealed.

is thus cooled, and when its temperature reaches the dew-point it becomes dimmed with dew. The flow is then stopped and the temperature, when the dimness just vanishes, is read. The experiment is then repeated as with Regnault's hygrometer.

In another form of Dines's instrument two reservoirs are used, one containing cold water, the other water at the air temperature. Better results are thus obtained.

174. Daniell's hygrometer. This is the oldest and most objectionable form of hygrometer. It has now been generally superseded by the others. In principle it is a simple modification of the cryophorus, containing ether instead of water. One of the globes, A (Fig. 130), is made of black glass, or has a zone of gilding round it, and contains a small thermometer t ; the other, B, is a plain glass bulb. The tube and attached bulbs are mounted on a suitable stand carrying a thermometer, t' , which serves to indicate the temperature of the air.

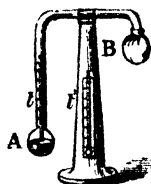

Fig. 130.

To use the instrument, all the ether is passed into A, and B is covered with muslin; a small quantity of ether is then poured on this muslin, from which it rapidly evaporates, and, in so doing, absorbs heat from B. The cold thus produced tends to condense the ether vapour in B; this causes rapid evaporation from the surface of the liquid in A, and consequently the temperature indicated by the thermometer t rapidly falls. As this goes on the surface of A is carefully watched, and the temperature, given by t , at which dew begins to form on it is carefully noted. The instrument is now left to itself until the dew thus formed on A entirely disappears, and the reading of t at the instant of disappearance is recorded. The dew-point is very approximately given by the mean of the two readings thus taken.

The temperature of the air is given by the thermometer t' , and thus sufficient data for the determination of relative humidity are obtained. It should be noticed that, in this

instrument, the cold produced by evaporation is utilised in two distinct ways: (1) in condensing the vapour in B, and thus causing evaporation of the liquid in A; and (2) in cooling the bulb A, so that the moisture of the air may be deposited upon it as dew, when the point of saturation (dew-point) is reached.

The disadvantages of this instrument are—

(1) The hygrometric state of the air is disturbed by the ether vapour around B and by the proximity of the observer.

(2) The thermometer t does not indicate correctly the temperature of the surface of A (for the liquid in A is at rest).

Exp. 131. Find the dew-point by one or more forms of hygrometer. At the same time use an absorption hygrometer to find the amount of water vapour in the air and deduce the dew-point from the result obtained and Regnault's tables. Compare the values obtained for the dew-points by the two methods.

175. Wet and dry bulb hygrometer.

This instrument is sometimes called *Mason's hygrometer*. It consists of two exactly similar thermometers (Fig. 131), mounted on the same stand in such a way that the air can circulate freely round their bulbs. One thermometer is used merely to give the temperature of the air; the other has its bulb covered with muslin, which is kept moist by means of an attached wick* communicating with a vessel of water. The evaporation which takes place from this wet bulb produces a fall of temperature,

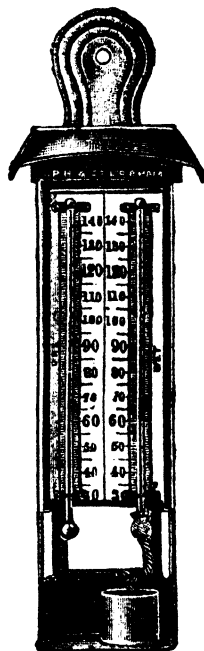

Fig. 131.

* The wick should be boiled in washing soda to remove grease, and then in water before attaching as above.

and consequently the wet bulb thermometer always reads lower than the dry bulb.

Now it is evident that this difference of temperature between the two thermometers, depending, as it does, on the cold produced by evaporation from the wet bulb, will be proportional to the rate at which evaporation takes place, and, as this depends on the quantity of moisture already in the air, we can see that the difference of temperature of the thermometers is indirectly related to the hygrometric state of the air. If this relation can be discovered it may serve to determine the humidity of the air, but, as the assumptions involved are somewhat doubtful, it is usual to determine the dew-point from the thermometric readings, by means of tables, empirically constructed from the simultaneous indications of a dew-point instrument.

In the first table shown below, which is due to Glaisher, the formula used in calculating the dew-point is

$$t - d = A(t - t_1),$$

where t° , t_1° , and d° F. are the temperatures of the dry bulb, wet bulb, dew-point respectively, and A is a factor which depends on the temperature of the dry bulb.

GLAISHER'S HYGROMETRIC FACTORS. *

Reading of Dry Bulb.	Factor.	Reading of Dry Bulb.	Factor.	Reading of Dry Bulb.	Factor.	Reading of Dry Bulb.	Factor.
$^\circ$ F.		$^\circ$ F.		$^\circ$ F.		$^\circ$ F.	
22	7.60	42	2.23	62	1.86	82	1.67
24	6.92	44	2.18	64	1.83	84	1.66
26	6.08	46	2.14	66	1.81	86	1.65
28	5.12	48	2.10	68	1.79	88	1.64
30	4.15	50	2.06	70	1.77	90	1.63
32	3.32	52	2.02	72	1.75	92	1.62
34	2.77	54	1.98	74	1.73	94	1.60
36	2.50	56	1.94	76	1.71	96	1.59
38	2.36	58	1.90	78	1.69	98	1.58
40	2.29	60	1.88	80	1.68	100	1.57

* From the *Observer's Handbook of the Meteorological Office.*

The values of *A* were determined by Glaisher from the comparison of thousands of simultaneous observations made with the wet and dry bulb thermometers and Daniell's hygrometer at widely varying temperatures.

The next table is on a different plan. To use it the readings must be converted to degrees Centigrade.

From the top line look out the *difference* between the wet and dry readings, follow down the column under this, and pick out the number that is on the same line as the air or dry bulb temperature in the first column. This number is *f*, the pressure in *mm.* of the vapour actually present in the air at the time of observation. The second column, under difference 0, gives the saturation pressures of aqueous vapour at the temperatures indicated in the first column. Hence look down the column under 0 for the number equal to *f*; the temperature beside this is the dew-point (interpolation may be necessary).

WET AND DRY BULB HYGROMETER. *

Air Temp.	Difference between Wet and Dry Bulbs in °C.											
	0	1	2	3	4	5	6	7	8	9	10	
°C.	Saturation Pressures in mm. of Mercury.											
0	4.6	3.7	2.9	2.1	1.3							
2	5.3	4.4	3.6	2.7	1.9	1.1	0.3					
4	6.1	5.2	4.3	3.4	2.6	1.8	0.9					
6	7.0	6.0	5.1	4.2	3.3	2.4	1.6					
8	8.0	7.0	6.0	5.0	4.1	3.2	2.3	1.4	0.6			
10	9.2	8.1	7.0	6.0	5.0	4.0	3.1	2.2	1.3			
12	10.5	9.3	8.2	7.1	6.0	5.0	4.0	3.0	2.1	1.2	0.3	
14	11.9	10.7	9.4	8.3	7.1	6.1	5.0	4.0	3.0	2.0	1.1	
16	13.5	12.2	10.9	9.7	8.4	7.3	6.3	5.0	4.0	3.0	1.9	
18	15.4	13.9	12.5	11.2	9.9	8.6	7.4	6.3	5.1	4.0	3.0	
20	17.4	15.9	14.3	12.9	11.5	10.2	8.8	7.6	6.4	5.2	4.1	
22	19.7	18.0	16.4	14.8	13.3	11.9	10.5	9.1	7.8	6.6	5.4	
24	22.2	20.4	18.6	17.0	15.3	13.8	12.3	10.9	9.4	8.1	6.8	

For intermediate temperatures take proportional values.

* From Smithsonian table, No. 170.

176. The mass of a given volume of moist air. To calculate this we require the following two facts:—

(1) The mass of one litre of dry air at 0° C. and a pressure of 760 mm. of mercury is 1·293 grammes.

(2) The mass of one litre of water vapour at any ordinary temperature and pressure is nearly $\frac{5}{8}$ of the mass of one litre of dry air at the same temperature and pressure.

Consider a volume of V litres of moist air at pressure P and temperature t° C. and let f denote the pressure exerted by the aqueous vapour present. The entire gaseous mass may be considered as made up of two parts:

(a) A volume V of dry air at pressure $(P - f)$ and temperature t° C., the mass of which is given by

$$M' = V \times 1.293 \times \frac{273}{273 + t} \times \frac{P - f}{760} \text{ grammes.}$$

(b) A volume V of water vapour at pressure f and temperature t° C., the mass of which is given by

$$m = \frac{5}{8} \left(V \times 1.293 \times \frac{273}{273 + t} \times \frac{f}{760} \right) \text{ grammes.}$$

Hence the total mass of the volume V of moist air is given by

$$\begin{aligned} M &= M' + m \\ &= \frac{V \times 1.293 \times 273}{(273 + t) \times 760} \left\{ (P - f) + \frac{5}{8}f \right\} \text{ grammes.} \\ &= \frac{V \times 1.293 \times 273}{(273 + t) \times 760} \left(P - \frac{3}{8}f \right) \text{ grammes,} \end{aligned}$$

which is less than the mass the air would have if dry.

Exp. 132. Take some hygrometers and from their readings find the dew-point and the relative humidity. Calculate the mass of a cubic metre of the air present in the atmosphere at the time and of the amount of water vapour in it.

Observe the dew-point (0° C.), the reading of the dry and wet bulbs (t° C. and t'° C.), the height of the barometer (h cm.), and its temperature (T° C.).

Record as follows:—

Wet and dry bulb hygrometer: temperature, wet bulb 12° C., dry bulb 15° C.

Regnault's hygrometer $\left\{ \begin{array}{l} \text{appearance of dew on cooling} \\ \quad 9\cdot5^{\circ} \text{ C.} \\ \text{disappearance of dew on warm-} \\ \quad \text{ing } 10\cdot5^{\circ} \text{ C.} \end{array} \right.$

Barometer: height 77·41 cm., temp. 15° C., brass scale.

Calculation of dew-point:

(1) From Regnault's hygrometer: dew-point = $\frac{1}{2}$ (9·5 + 10·5) = 10° C.

(2) From wet and dry bulb hygrometer:

(a) From Smithsonian table. Difference in temperature between wet and dry bulb = 3° C.; therefore by the table the saturation pressure = mean of 8·3 and 9·7 = 9·0 mm. of mercury, therefore the temperature of the dew-point

$$= 8\cdot0 + \frac{1\cdot0}{1\cdot2} \text{ of } 2\cdot0 = 9\cdot7^{\circ} \text{ C.}$$

(b) From Glaisher's table. Dry bulb reading = 15° C. = 59° F; Wet bulb reading = 12° C. = 53·6° F.

$$\therefore 59 - d = 1\cdot89 (59 - 53\cdot6) = 1\cdot89 \times 5\cdot4 = 10\cdot2.$$

$$\therefore d = 49^{\circ} \text{ F.} = 9\cdot5^{\circ} \text{ C.}$$

The average value of the dew-point is the mean of the above three results = 9·7° C.

Calculation of relative humidity:

Maximum vapour pressure at the air temperature 15° C. = 12·7 mm. (see table, p. 273).

Maximum vapour pressure at the dew-point 9·7° C. = 8·9 mm. (see table, p. 273).

$$\therefore \text{relative humidity} = \frac{8\cdot9}{12\cdot7} = \cdot70, \text{ or } 70 \text{ per cent.}$$

Height of barometer (corrected to 0° C.)

$$= 77\cdot41 (1 - \cdot000162 \times 15) \dots\dots\dots (\text{Art. } 62).$$

$$= 77\cdot41 - \cdot000162 \times 15 \times 77\cdot41$$

$$= 77\cdot22 \text{ cm.}$$

Calculation of mass of a cubic metre of moist air :

Total pressure = 77.22 cm., the vapour pressure = 8.9 m.
= .89 cm.

∴ pressure of the dry air = 76.33 cm.

∴ mass of the dry air = $1293 \times \frac{273}{288} \times \frac{76.3}{76} = 1231$ gm.

and mass of the water vapour = $\frac{5}{8} \times 1293 \times \frac{273}{288} \times \frac{.9}{76} = 9$ gm.

∴ total mass = 1240 gm.

177. Hygrosopes are contrivances with hair, catgut, etc., which serve to indicate the humidity of the air by means of some physical effect produced by the absorption of moisture.

Many substances absorb moisture to a degree dependent on the quantity present in the air, and this absorption is generally accompanied by some variation in the form or condition of the substance. The nature of the variation depends on the structure; for instance, membranous bodies, such as paper, parchment, etc., expand and contract according as they absorb or lose moisture; filamentous substances change much more in thickness than in length; ropes, strings, and threads, which are composed of twisted fibres, swell out and shorten* on the absorption of moisture. Hair, owing to its peculiar structure, shortens as the humidity increases. A single hair is made up of a series of cones fitting one into the other; on absorption of moisture it swells out, and the vertical angles of the cones increase. Consequently the cones become flatter and the length of the hair decreases.

De Saussure's hygroscope (Fig. 132) is of historic interest, as being the first instrument devised for hygrometric purposes. It consists of a hair from which all

* It should be noticed that the individual fibres of a rope, etc., probably increase *slightly* in length, but the rope, as a whole, shortens for the same reason that a number of thick strings form, on twisting, a shorter rope than the same number of fine strings of the same length twisted to the same extent.

grease has been removed by washing it in a solution of soda. It is fastened at the top to a screw-pin, and at the lower end passes once round a pulley, and carries a small weight, which keeps it tightly stretched. Attached to the pulley is a needle, which indicates on a scale the change in length of the hair corresponding to changes in the humidity of the air. The scale round which the needle moves is graduated to indicate various degrees of humidity, but the indications are only relative, and the instrument is never used for accurate scientific work, but serves a useful purpose as a recording instrument.

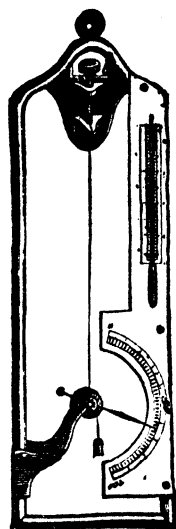

Fig. 132.

178. Formation of cloud and rain. Clouds are formed by local condensation of the water vapour present in the air in the upper regions of the atmosphere. They consist chiefly of very minute drops of water, which, on account of their small size, fall very slowly through the air.

One method of cloud formation is illustrated by what takes place in Exp. 126. The jet of steam issuing from the flask supplies water vapour more rapidly than it can be distributed throughout the air by diffusion. Hence in the region of over supply the vapour condenses and forms a small "cloud."

In nature this process of cloud formation occurs sometimes, but it is by no means the commonest process. It is well known that if the pressure on a gas is reduced the volume increases, and if no heat is passed into the gas from without the gas becomes colder, and if the process is carried far enough any water vapour in the gas separates out in minute drops.

Exp. 133.—Place a little water in a large flask and shake well, so that the air in the flask becomes saturated with water vapour. Now apply the mouth to the flask and give a quick exhaust. The interior of the flask fills with mist.

In nature cooling of air consequent on decrease of pressure occurs when a mass of air leaves the surface of the earth and ascends to upper regions. At first cloud is formed and ultimately rain is produced. In fact, some meteorologists regard an ascending current of air as *necessary* for the production of a measurable rainfall.*

It should be specially noted that cloud really marks a region of condensation which is fed by vapour from the flask, and is limited in extent by continuous vaporisation and diffusion from its outer surface. The cloud is therefore not a floating mass of unchanging material, but a constantly changing mass of condensed vapour, which is continuously formed by condensation in the condensation region, and is as rapidly dissipated by vaporisation and diffusion at its outer surface. A cloud cannot therefore be said to float; it is merely a formation marking any region in which the conditions which determine condensation may obtain.

The great variety of cloud-forms is due to the variety of the conditions under which they are formed. By the methods indicated above huge clouds known as **cumulus** clouds form at the top of the ascending columns. Similarly, when currents of air at different temperatures meet, the layers of contact may become regions of condensation, and clouds, often of the **stratus** type, may form in these regions.

In the case of clouds formed at great heights, where the temperature is very low, the constituent drops may be frozen into small ice particles, or the vapour may be condensed in minute ice crystals, forming the beautiful clouds known as **cirrus** clouds. The dark rain clouds of cumulus-like structure are called **nimbus** clouds.

* Cases in point where clouds and rain are continuously being formed by this means are seen on the mountainous West Coast of South America. The prevailing westerly winds laden with moisture, as they travel up the mountain side, rapidly reach regions of low atmospheric pressure, and the water separates out, giving a copious rainfall. The same occurs to a less extent when south-westerly winds laden with water vapour from the Atlantic Ocean meet the hills of N.W. and S.W. England and Wales.

If the lower layers of air are saturated the small cloud particles collect into drops and fall as rain. If the cold is sufficiently intense to freeze the minute particles before they collect into rain-drops a fall of snow results. If the rain-drops form and are then frozen the result is hail.

Rain gauges are instruments designed for the measurement of the amount of rain that falls in a given time, which is usually 24 hours. The usual form consists of an outer vessel of copper which supports a copper funnel 5 in. in diameter fitted with an upright rim at the top. The stem of the funnel dips into an inner receiver of copper, in which the water collects. When the observer visits the gauge he pours the water from the inner receiver into a glass measuring-jar, and then employs a numerical factor to turn the amount of water as measured in the jar into "inches of rainfall."

179. Formation of fog or mist and haze. When the vapour in the air condenses in regions at or near the surface of the earth *fog* or *mist* is produced. The mode of formation of fog is practically the same as in the case of a cloud, the difference in the appearance of the phenomena being mainly due to the fact that clouds are formed at considerable heights above the observer, while fogs and mists are formed near the surface of the earth. In the case of fog, however, the masses of air involved are often at rest or in very slow motion, and the bank of fog produced is more stationary and fixed in form than a cloud usually is.

The most frequent cause of fog is the cooling of the air below the dew-point. The fog region near Newfoundland, for example, is due to the cooling of the warm vapour-laden wind from over the Gulf Stream by the cold air of the Labrador current. Similarly, when warm saturated air flows up a mountain side the cooling consequent on the expansion produces a thick mist around the mountain top.

Fogs often form in river valleys and over lakes. If the water is warmer than the air a fog is formed by the oversupply of vapour from its surface. If, however, the water is colder than the air the layers of air in contact with it are cooled below the dew-point, and a fog or mist appears. As explained above, the formation of fog is greatly facilitated by the presence of small particles of matter in the

air. It seems probable, indeed, that nuclei of some kind are essential as centres of condensation for the formation of a fog. This explains the frequency of dense fogs in large towns. The smoke and dust particles in the air serve as convenient centres of condensation, so that directly the air is cooled below the dew-point, a fog composed of comparatively large drops of water with a core of soot or dust is produced.

To meteorological observers the words fog, mist, haze, indicate a deterioration of the transparency of the lower regions of the atmosphere caused by solid or liquid particles. Mist and fog refer to surface cloud, and the air is saturated with water vapour when they occur. A slight fog is sometimes called a haze, but it is better to keep the term haze to the obscurity caused by smoke, dust, or other cause when the air is dry. In large cities the smoky surface cloud which occurs when the air is calm and dry is usually called a fog; it would be better termed a thick haze.

Some draw a distinction between mist and fog by regarding a mist as a surface cloud which wets objects exposed to it, and a fog as a surface cloud which does not wet exposed objects. The distinction is, however, scarcely practical. Fog seems always to imply inconvenience to travellers, and it is in this sense that the term may be most safely used; the same cloud may be a fog to a person travelling in it, and a mist to a person looking at it from a distance.

180. Formation of dew.* A satisfactory theory of the formation of dew was first given by Wells. During the day objects on the surface of the earth are heated by direct radiation, and the air in contact with them is also heated, and generally contains a large quantity of aqueous vapour. During the night cooling takes place, and substances which radiate well quickly cool below the temperature of the surrounding air. As a consequence the air in contact with these bodies also cools, and ultimately the *dew-point* (Art. 169) is reached, at which the air is saturated with the vapour it contains, and if further cooling takes place a portion of the vapour is deposited as dew on the surfaces of the adjacent bodies.

* This cannot be fully understood until Ch. XIV. on Radiation has been read.

On this theory it is evident that the following conditions are necessary for a copious deposition of dew:—

1. A clear sky, to allow free radiation into space.

2. A calm state of the atmosphere, in order that the air in contact with any object may remain in position until cooled below the dew-point.

3. The objects on which dew is deposited must be—

(a) Good radiators, in order that they may cool rapidly.

(b) Bad conductors, in order that the loss of heat by radiation may not be counterbalanced by a gain of heat from the earth by conduction. If the body is isolated and of small size it does not matter whether it is conducting or not.

(c) Placed near the earth. When the substance is some distance above the earth the air in contact with it, on being cooled, sinks towards the earth, and its place is supplied by warmer air from above. In this way none of the air which comes in contact with the body may be sufficiently cooled to deposit its vapour as dew.

For example, it is often found that certain objects are quite wet with the dew, while neighbouring ones may be almost free from it. Grass is always more heavily bedewed than gravel or pebbles in its vicinity, and a polished metallic surface may remain quite dry among the dewy grass. The explanation of this is that grass radiates well, loses its heat quickly, and thus lowers considerably the temperature of the overlying air. Pebbles, gravel, and polished surfaces do not radiate so freely, and may not become cold enough to reduce the temperature of the air above them to the dew-point.

The temperature of the surface of a large body embedded in the ground will also depend on its conductivity; for as the top surface is cooled by radiation heat will flow to it from the interior, which is at a higher temperature. Thus we see that the largest quantities of dew are formed on bodies which are good radiators and bad conductors.

Wells' theory has been confirmed by recent investigation, but other experiments have shown that dew is derived not only from vapour present in the air, but also from vapour

arising from the earth and from the vegetation on which the dew is formed.

181. Formation of hoar-frost, rime, and glazed frost. Hoar-frost resembles dew in its mode of formation. If the objects on which the water is deposited are below 0° C. the water freezes at once, and the projecting edges of the objects are outlined in tiny ice crystals. This constitutes hoar-frost.

Rime. This is an accumulation of frozen moisture on trees and exposed objects, which thus present a silvery white and rough appearance. Rime bears some resemblance to hoar-frost, but rime only occurs in a fog, whilst hoar-frost occurs on clear nights. The white deposit on grass which is often seen on cold foggy mornings is not rime, but hoar-frost formed before the development of the fog.

Glazed frost. This is a transparent glass-like coating of ice covering trees, buildings, etc. It is usually caused by rain which freezes as it reaches the ground. It may also occur when a warm moist air current sets in suddenly after intense cold. The moisture of the air separates out on cold surfaces and coats them with ice.

182. Other meteorological phenomena.

Wind. Wind is air in motion, the motion being due either to convection (see Ch. VII.) or to the rotation of the earth or to both. The two factors usually measured in connection with wind are (1) the direction from which it is blowing and (2) its "force" or velocity. The direction is given by wind-vanes, smoke, etc., and the velocity is either estimated by noting its physical effect on surrounding objects such as trees, etc., or measured by an **anemometer**.

The usual form of anemometer is *Robinson's cup anemometer*. It consists of four hemispherical cups attached to the end of two crossed metal arms. The cross is pivoted at its central point in such a way as to be free to rotate in a horizontal plane. The difference of pressure of the wind on the convex and concave surfaces of the cups causes the cross to spin around. The number of revolutions of the cups in a given time is proportional to the amount of wind which passes them, and the total number of revolutions is recorded on a dial graduated to read to "miles of wind." The more elaborate forms are arranged to give a continuous record.

Cyclones and Anticyclones. A cyclone is a region of low barometric pressure. In general cyclones drift over the

United Kingdom from West to East, and their passage is usually accompanied by high winds and unsettled weather, cool in summer and warm in winter. An anticyclone is a region of high pressure. In general the motion of anticyclones are very irregular. Their presence usually means light variable winds and fine weather, hot in summer and cold in winter. For a further study of cyclones and anticyclones the student should refer to a text-book of meteorology or physical geography or nature study.

Sunshine recorders. The Campbell-Stokes sunshine recorder consists essentially of two parts: (1) a glass sphere (4 in. diam., focal length, 3 in., measured from the centre) which brings the sun's rays to a focus, (2) a metal bowl carrying cards to form a belt, approximately spherical, on which the sun burns a record. The instrument is placed facing South and the hours of sunshine can be read off from the length of the burnt trace.

In some parts of the country long strips of seaweed are kept as weather indicators. On the approach of wet weather the salt in the weed absorbs moisture and the weed becomes wet and slimy. "Corns" also serve some people as efficient weather indicators, and many animals have an intuitive fore-knowledge of weather changes.

It may be mentioned at this point that meteorological observations have shown conclusively that there is no connection between the moon and the weather.

EXERCISES XII.

1. Why will spectacles often become dim on a frosty day if the wearer goes direct from the open air into a warm room? Why does the dimness soon pass away?

2. (a) On a hot summer day, immediately after a rain-storm, a block of ice on a cart appears to be "steaming." (b) On a winter's day a river sometimes "steams." Explain these phenomena.

3. A mist is often said to "rise from" the ground. Explain in what sense this phrase is incorrect.

4. Explain the phenomena of snow, hail, and hoar-frost.
5. How is the reading of a thermometer altered by wrapping a wet rag around the bulb? What will happen if the rag is wetted with (1) ether, (2) oil instead of water? How do you explain the various results?
6. Two cubic metres of air at 17°C . were drawn through an absorption hygrometer, and 24.12 gm. of water were deposited in the tubes. Find the relative humidity of the air.
7. Find the hygrometric state of the air at 20°C ., the dew-point being 10°C .
8. Find the dew-point when the relative humidity at 26.4°C . is 20 per cent.
9. Find the mass of a litre of moist air at 18°C ., the dew-point being 5°C . and the barometric height 757.5 mm.
10. Two hundred c.c. of hydrogen, measured at 15°C . and 754.7 mm. pressure, are collected over water. Find the mass of the hydrogen present. (1 litre of hydrogen at 0°C . and 760 mm. pressure weighs 0.0900 gm.)
11. Show the importance in the economy of Nature of the following properties of water: (1) its great specific heat, (2) its great latent heat of fusion, (3) its great latent heat of vaporisation, (4) its expansion on freezing, (5) its greatest density occurring some distance above its freezing point.

EXAMINATION QUESTIONS ON THE HIGHER CHANGE OF STATE AND HYGROMETRY.

1. What is *vapour pressure*?
A long barometer tube can be moved up and down in a deep vessel nearly filled with mercury. The reading of the barometer is 75 cm. A few drops of water are introduced into the barometer tube, and the height of the mercury column falls to 73.5 cm., a film of moisture being visible on the top of the column. Explain the fall and state, giving reasons, whether the height of the barometer column or the amount of moisture visible would alter if the tube were gradually (1) raised, (2) lowered, in the vessel.
2. A and B are two barometers. A has a little air above the mercury, while B has a little air and a drop of water. The readings of the two barometers happen to be equal at the temperature of the room. Will they still be equal when the temperature is raised or lowered, and, if not, which will give the higher reading?
3. How would you measure the maximum vapour pressure of a liquid at temperatures below its boiling point?
Give a sketch showing the *general* shape of the curve representing the relation between the vapour pressure and temperature for water.

4. Describe how to measure the maximum pressure of aqueous vapour at various temperatures. Would it be possible to use any kind of vapour as the active substance in a thermometer?

5. Describe the properties of saturated and non-saturated vapours.

A barometer tube dipping into a mercury reservoir contains a mixture of air and saturated vapour above a column of mercury which is 70 cm. above the level in the reservoir, the atmospheric pressure being 76 cm. What is the height of the mercury column when the tube is depressed so as to reduce the volume occupied by the air to one-half of its original value, the pressure of the saturated vapour being 1.5 cm.?

6. Determine the height of the barometer when a milligramme of air at 27° C. occupies a volume of 20 cub. cm. in a tube over mercury, the mercury standing 73 cm. higher inside the tube than outside.

[The volume of air at 0° C. under pressure of 76 cm. of mercury is 773.4 c.c.]

7. Describe and explain the apparent transfer of cold in the cryophorus.

8. What is the spheroidal state of a liquid? Why can liquid oxygen be poured on the hand with impunity?

9. Explain carefully the statement that the latent heat of fusion of water is 80. What is the unit in terms of which latent heat is measured? Trace the changes in the temperature and volume of a kilogramme of ice at -5° C., to which heat is applied until it is converted into steam.

10. Explain carefully how the latent heat of evaporation of a liquid such as alcohol may be determined at different temperatures. Point out any sources of error, and explain how they may be eliminated.

11. A mass of 200 gm. of copper (sp. heat 0.1) is hung in a closed chamber at a temperature of 59° F. Steam is then admitted at the normal atmospheric pressure. Calculate the mass of water condensed by the copper.

12. A copper sphere is suspended by a fine wire in a chamber whose temperature is 20° C. Steam at 100° C. is then blown through the chamber until the temperature of the chamber and steam is steady at 100° C. Explain carefully why the sphere becomes coated with a definite quantity of moisture. If the steam is cut off before this steady temperature is attained, the highest common temperature of the sphere and moisture being 70° C., calculate the quantity of moisture on the sphere, the mass of the sphere being 100 gm., the specific heat of copper 0.1, and the latent heat of vaporisation of water at 100° C. 540 calories per gm.

13. The specific heat of a certain liquid is 0.42 calorie per gm. per degree C., and its latent heat of vaporisation at its boiling point, 60° C., is 350 calories per gm. Calculate how much steam must be condensed in a tube leading through it to warm 2 kilogr. of the liquid from the air temperature 15° C. to the boiling point of the liquid, and to boil away 20 gm. of the liquid. The condensed water remains in the tube. The thermal capacities of the containing vessel and condensing tube may be neglected.

14. A calorimeter whose capacity for heat is 48 calories has 352 gm. of water in it, and the whole weighs 882.0 gm. Into this steam at atmospheric pressure is condensed till its temperature rises from 12.2° C. to 18.7° C., and on weighing again the calorimeter weighs 886.2 gm. Find the latent heat of vaporisation of water.

15. What is known about the latent heat of vaporisation of water at different temperatures?

If a boiler receives 30,000 calories per minute through every square metre of its fire-box surface, the total surface being, say, 5 square metres; and if its temperature be 140° C., while it is fed with condenser water at 45°; what weight of steam would you expect to be able to regularly draw off per hour? (Assume that the specific heat of water up to 140° C. is unity and that the latent heat of vaporisation of water at 140° C. is 515.)

16. Describe the steam calorimeter and explain how it has been used to determine the specific heat of gases at constant volume.

17. Describe any direct method of measuring the specific heat of air (1) at constant pressure, (2) at constant volume.

18. What is meant by *dew-point*? Describe an instrument for determining its value, explaining how to take a careful observation.

Given a barometer, an instrument for determining the dew-point, and a table showing the pressure of saturated water vapour at different temperatures, how would you estimate the pressure of the dry air, and that of the water vapour, in the atmosphere?

19. 100 c.c. of oxygen, saturated with water, are collected at a pressure of 740.0 mm. and a temperature of 15° C. Find the volume of dry oxygen at 0° and 760 mm., having given that the maximum pressure of aqueous vapour at 15° is 12.7 mm. of mercury.

20. Under what conditions are dew, mist, and hoar-frost formed? On spreading a woollen rug over a part of a gravel path at night, dew will be formed upon the rug far more readily than upon the path. Explain this.

21. On a clear still evening, after a wet summer's day, mist seems to rise from a grass lawn. Explain carefully how the mist forms.

Would covering the grass with canvas prevent the formation of mist? Give reasons.

CHAPTER XIII.

CONDUCTION OF HEAT.

183. Three modes of transference of heat. Heat may be transferred from one point to another in three different ways—*conduction, convection, radiation*. In *conduction* heat imparted to any part of a body sets the molecules of that part in more energetic vibration. These transmit the vibration to their neighbours, and thus the heat travels slowly along. In *convection*, which is only possible in gases and liquids, the parts heated expand, and, becoming less dense, rise and carry their heat *by their own motion* to other parts. In *radiation* the hot body imparts its vibration to the ether (see Art. 200), in which waves are set up which travel outwards in all directions with an enormous velocity, and through vacuous spaces even more freely than through air or other matter.

Convection has been treated already in Ch. VII., Radiation will be treated in Ch. XIV.

184. Thermal Conductivity. The fact that heat may be transmitted or conducted through the substance of a body is familiar from every-day experience. When the end of a poker is placed in the fire the heating effect is not confined to the portion actually in the fire. The portion outside the fire is also heated in a way which indicates that heat must be conducted through the substance of the poker from the end in the fire towards the other end. When boiling water is poured into a metal vessel the *outside* of the vessel quickly becomes hot, showing that heat has been conducted through the thickness of the vessel. When a fire is lighted in a closed range the portions of the range

not in direct contact with the fire become heated by the heat conducted from the fire through the iron of the range. If a flat-iron or block of any substance is placed on a hot-stove plate it becomes heated throughout its mass by the conduction of heat from its under surface.

The power which a substance possesses of allowing heat to be conducted through it is known as the **thermal conductivity** of the substance.

185. Substances differ in thermal conductivity. Substances differ greatly in their power of conducting heat. A rod of wood if placed with one end in the fire gives little indication of the conduction of heat outwards from the end in the fire. If boiling water is poured into a thick wood vessel the heating of the outer surface is very slight. It also takes place very slowly.

The difference in the heat sensations experienced on touching different substances is also, as explained in Ch. I., due to difference in the conductivity of the substances. For example, in the hot room of a Turkish bath where all the objects are at the same temperature, metallic objects feel much hotter than others and may inflict a burn. Similarly in a cold room metallic objects feel very cold to the touch, while wooden objects, carpets, clothing, and other similar objects give no pronounced sensation of cold, and yet all the objects in the room may be shown to have the same temperature by bringing them successively in contact with a thermometer. This difference of sensation is obviously due to a difference in the conductivity of the substances touched; good conducting substances such as metals rapidly conduct heat to or from the hand and thus cause a more marked sensation of heat or cold.

The following experiments further illustrate the difference in the conductivity of different substances:—

Exp. 134. Fit the end of a short wooden cylinder into a thick brass tube of the same external diameter. Wrap a piece of *thin* paper round the cylinder at the junction of the wood and brass and hold the paper in the flame of a spirit lamp or Bunsen burner.

It will be found that the paper over the wood is badly scorched, while that over the brass is not scorched. This is due to the fact that the brass, being a good conductor, conducts the heat away from the paper sufficiently rapidly to prevent scorching, whereas the wood being a bad conductor is unable to do this.

Exp. 135. Repeat **Exp. 134**, using *thick* paper. It will be found that the paper is scorched wherever the flame touched it. The low conductivity of the paper prevents the heat from being transmitted through its thickness, and the presence of the good conducting brass beneath has therefore no effect on the result.

Exp. 136. Take similar strips of silver, copper, and iron and place them with one end in hot water in a beaker. The other end of the silver strip soon becomes very hot, the copper also gets hot, but not to the same degree as the silver, while the iron strip is heated to much less extent than either the silver or the copper.

Exp. 137. Twist an iron and a copper wire together at one end. At four or five inches from the joint fasten a small lead pellet on each wire with beeswax. Heat the joint in a Bunsen flame. Heat is conducted from the joint outwards along each wire and the temperatures of the wires at the points where the pellets are attached will be raised to the melting point of the beeswax and the pellets will drop off. Notice that the pellet on the copper wire is the first to fall, showing (in this case) that the conductivity of copper is higher than that of iron. (See **Exp. 143**.)

In general, metals are good conductors of heat. Organic substances such as wood, bone, felt, are bad conductors. Brick is also a feeble conductor, while stone, marble, slate, glass, though better conductors than brick and organic substances, are of much lower conductivity than metals.

The fact that some substances have a low conducting power has many familiar applications. Handles of wood or other badly conducting material are usually provided to tools, hot water vessels, and other appliances where the hand has to be protected from heat which might otherwise reach it by conduction. In the case of tea-pots, coffee-pots, kettles, etc., the handle is sometimes of metal, but

in that case the handle is separated from the body of the vessel by discs of china or other badly conducting substance.

Exp. 138. A kettle that has been long in use has a thick coating of carbon on the bottom. To show that this coating is a bad conductor, boil water in the kettle, and then support the kettle on the palm of the hand. The kettle and water feel only moderately hot.

The efficacy of clothes and bed clothing is due to their low conductivity. The heat developed in the body is prevented from escaping by the covering of badly conducting material and thus the feeling of warmth is maintained.

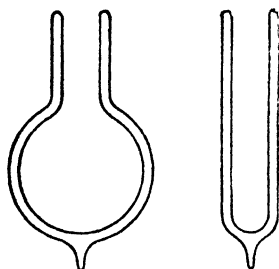

Fig. 133.

A good example of this retention of heat by a hot body surrounded by a bad conductor of heat is found in what is called a *Norwegian cooking box*, which consists of a wooden box with a thick lining of felt so arranged as to leave a central cylindrical space into which the vessel containing the food fits. The food is partly cooked over the fire in this vessel and while still hot is placed in the

box. The lid, also felt-lined, is then lightly closed over it. The heat is so well maintained that the cooking is completed in the box, and after an interval of some hours the temperature will have fallen only a few degrees.

Bad conductors are as effective in keeping a body cool as in keeping it warm. Thus a covering of felt or flannel which will keep a vessel of hot water warm will also keep a piece of ice from melting. In the one case heat is prevented from passing out from the water and in the other from passing into the ice.

A vacuum is a perfect non-conductor of heat. Double-walled vacuum vessels of glass are now made of the forms shown in Fig. 133. They consist of a flask or tube inside another, the two being sealed together at the top and the space between them exhausted of air as completely as

possible through a fine tube at the bottom of the outer vessel, which is then sealed off. As a rule the surfaces of the vessels next the vacuum are silvered to prevent loss or gain of heat by radiation (see Arts. 213, 215). These vessels were first designed for the storage of liquefied gases, which would boil away at once if placed in ordinary vessels. Liquid air may be kept for days in a good vessel. They are now also largely used in the form of "Thermos" flasks for keeping hot drinks hot and cold drinks cold for a long time.

Exp. 139. Place some hot water in a metal vessel and note its rate of cooling when placed on a large metal plate without any protection from loss of heat by conduction. Then repeat the observations when the vessel is protected by a covering of felt or by being supported on cork or suspended inside another vessel. Compare and explain the result.

186. The principle of the Davy Lamp. When we apply the flame of a lighted match to gas issuing from a jet the temperature of the gas is raised above its temperature of ignition and combustion commences and continues so long as a supply of oxygen is obtainable and the temperature remains above the ignition temperature of the gas.

If, however, a piece of good conducting material be placed in a flame it may conduct away the heat so rapidly that the temperature falls below the temperature of ignition and combustion ceases. This effect is illustrated by the following experiments.

Exp. 140. Take a piece of thick copper wire and coil it into a spiral of about half a centimetre internal diameter. Light a candle, and when the flame is burning strongly lower the coil of copper wire on to the wick of the candle. The flame at once goes out.

Exp. 141. Take a piece of clean copper gauze, not too fine in mesh, and lower it on to the flame of a Bunsen burner or spirit lamp. It will be found that the flame does not get through the gauze. As the gauze is lowered the flame is kept below it and may be extinguished completely by lowering the gauze on to the burner or wick. The gauze conducts the heat away from the portion of the flame in contact with it sufficiently rapidly to lower the

temperature below that at which combustion takes place, and the region of combustion is therefore unable to extend above the gauze.

If the gauze is held over the flame until it is heated to the temperature of ignition it ceases to be effective for the purpose of this experiment.

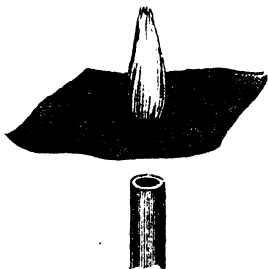

Fig. 134.

Exp. 142. Hold a sheet of gauze about an inch above a Bunsen burner and light the flame *above* the gauze (Fig. 134). It will now be found that the flame appears only above the gauze and is prevented by the conductivity of the gauze from extending below it.

The principle illustrated by these experiments has been utilised in the construction of the Davy lamp, the Clanny pattern of which is shown in Fig. 135. The flame of the lamp is enclosed in a cylinder of wire gauze so that when the lamp is placed in an explosive atmosphere the gases which penetrate to the flame are ignited and burn *inside* the gauze with a peculiar flickering, but the flame produced is unable to extend outwards through the gauze unless the gauze becomes hot. The explosion which would be produced by a naked light is thus averted. As soon as the miner notices the presence of the ghostly fire-damp flame he leaves the working at once and gives notice to his foreman, whereupon the mine is thoroughly ventilated.

It has been found, however, that the Davy lamp is not, in all cases, an efficient protection against explosions in mines.

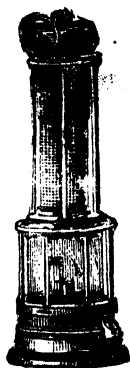

Fig. 135.

187. The stationary and variable states during thermal conduction. Imagine a bar placed with one end in the fire, and let us consider what takes place as the heat is

transmitted outwards from the fire, along its length. The portion in the fire rapidly increases in temperature and finally takes the temperature of the fire; meanwhile, as the temperature of this portion rises the transverse layer adjacent to it receives heat by conduction, absorbs part of this heat to increase its own temperature, loses a small portion by radiation from its surface and passes on the rest to the adjacent layer, where the process is repeated. When this has gone on for some time a state will ultimately be reached when each layer attains a stationary temperature and ceases to absorb any of the heat passed on to it by the adjacent layer nearer the fire.

This state has been called the **stationary** or **permanent state**, and the passage of heat along the bar, when this state is attained, depends, for given conditions, on the conductivity of the material of the bar. The stage previous to the attainment of this stationary or permanent state is known as the **variable state**, for, while it lasts, each layer absorbs some portion of the heat it receives, and is consequently rising in temperature.

During the stationary state each layer passes on to the next *less* heat than it receives by the amount which it loses at its outer surface. Hence, if there is any considerable loss of heat from the outer surface, the quantity of heat that passes from layer to layer rapidly decreases, and, at a comparatively short distance from the source of heat, the flow of heat along the bar becomes negligibly small. It is evident therefore that in comparing the conductivities of different substances by comparing the flow of heat along similar bars of these substances not only must the bars be similar in shape and dimensions, but the nature of the outer surface must also be exactly the same for each bar.

188. Gradient of temperature. In all cases of conduction the rate of transmission of heat, that is, the quantity of heat transmitted per second, in any direction, is found to depend upon the fall of temperature per unit distance in that direction. This *fall of temperature per unit distance* for any direction is called the *gradient of temperature for that direction*. The gradient of temperature for any

direction may vary from point to point along that direction, and it is measured at any point by the average gradient over a very short distance taken at the point. For example, in the case of a bar heated at one end the gradient of temperature along the length of the bar decreases from point to point as the distance from the hot end increases. Also, if in a certain portion of the bar there is a fall of 3°C . in 2 mm., the gradient of temperature at the middle of this length of 2 mm. is 15°C . per cm.

189. Influence of specific heat during conduction. The rate at which heat is conducted through any substance, during the *variable state* of the process, depends not only on the conductivity of the substance, but also on its specific heat and density. The product of these is the heat needed to raise unit volume 1°C . If this product is low the temperatures of the successive layers rise quickly to the stationary points, even when the conductivity is comparatively low, for only a small portion of the heat that travels along is required to heat the substance. Similarly, if the specific heat is high the temperatures of the successive layers may rise slowly to the stationary values, even when the conductivity of the substance is fairly high.

This question is illustrated by the following experiment :

Exp. 143. Place two bars of iron and bismuth, of the same size and shape, and having an exactly similar surface, end to end, as shown in Fig. 136. To the under surfaces



Fig. 136.

attach with wax small wooden balls, at equal distances along the length of the bars, and heat the bars at their contiguous ends. As the heat is transmitted along their lengths,

the wax melts and the balls drop off in succession.

Now the first ball will drop off directly the temperature of the point at which it is attached becomes equal to the melting point of wax, and, provided the distance of this

point from the source of heat be not too great, the time required for this to take place depends not mainly on the conductivity but on the specific heat of the material of the bar; because, the lower the specific heat of this material, the greater will be the rise of temperature produced in a given volume of it by the heat supplied in a given time. For this reason the balls begin to drop off first from the bismuth bar, for the specific heat of bismuth is much less than that of iron, but the greater number of balls will ultimately drop off from the iron bar, for the conductivity of iron is much greater than that of bismuth, and, the greater the flow of heat along the bar, the further will the rise of temperature necessary to melt the wax be transmitted.

190. Definition of thermal conductivity. Imagine a large plate or wall of any substance, with parallel faces which are maintained at constant temperatures differing by a definite known amount, and consider the conduction of heat during the stationary state through the thickness of this wall from one face to the other. Near the edge of the plate some heat flows laterally outwards and escapes from the edge before passing through the plate, but if we take a small portion of the plate near the centre and at a distance from the edge, it may be assumed that all the heat which enters over any small area on the hot face of the plate passes straight through, *without lateral loss*, and emerges from the corresponding equal area on the cold face.

Under these conditions the quantity of heat which crosses any area of the plate depends upon four things, viz.—

1. The substance of the plate.
2. The area across which the flow of heat takes place.
3. The *gradient of temperature* in the plate, that is, the *difference of temperature per unit thickness* of the plate.
4. The time for which the flow of heat is taken.

It is found that, for a given substance, the flow of heat through the plate is directly proportional to—

1. The area across which the flow takes place.
2. The gradient of temperature in the plate.
3. The time of flow.

The quantity of heat, therefore, which flows in *unit time* through *unit area* of a plate in which there is a *gradient of temperature of one degree per unit thickness* depends only on the substance of the plate and may be taken as a measure of the *thermal conductivity* of the substance.

Definition. *The thermal conductivity of a substance is measured by the quantity of heat which flows in unit time across unit area of a plate of unit thickness having one degree difference between the temperatures of its faces.*

Thermal conductivity defined this way is sometimes called the *absolute thermal conductivity* of the substance.

191. Formula involving the definition of absolute thermal conductivity. For the purpose of calculation it is convenient to put the statements given above in algebraical form.

Let A denote the area, θ the *difference* between the temperatures of the faces, x the thickness of the plate, and t the time of flow; then, as θ/x is the gradient of temperature for the direction of flow, we have

$$H \text{ is directly proportional to } A \cdot \frac{\theta}{x} \cdot t,$$

where H denotes the quantity of heat which passes through the area A of the plate in time t . That is,

$$H = k \cdot A \cdot \frac{\theta}{x} \cdot t,$$

where k is a constant which measures the **absolute thermal conductivity** of the substance.

This equation may also be written $H = k \cdot A \cdot G \cdot t$, where G is the temperature gradient.

It is evident that if $A = 1$, and $\frac{\theta}{x}$ or $G = 1$, and $t = 1$, then $H = k$ as stated in the definition given above.

In applying this relation any *consistent* set of units may be adopted. The system in most general use is the C.G.S. system, where A is in sq. cm., x in cm., t in seconds, θ in degrees C., and H in calories.

Example. It is found that the temperature of the rocks below the Earth's surface increases at the rate of (approximately) one degree C. for each 30 metres of descent. Taking the thermal conductivity of the rocks as .005 on the C.G.S. system, calculate how much ice would be melted by the heat arriving in the course of a year at a square metre of the Earth's surface from its interior.

Here, the area across which the flow of heat has to be considered is 1 square metre or 10000 sq. cm., the gradient of temperature towards the Earth's surface is 1/30 degree C. per metre or 1/3000 degree C. per cm., and the time for which the flow is required is 1 year or $1 \times 365 \times 24 \times 60 \times 60$ seconds.

Hence we have

Calories of heat arriving per sq. metre of surface per year

$$= .005 \times 10000 \times \frac{1}{3000} \times 365 \times 24 \times 60 \times 60.$$

It requires 80 gm. degrees to melt 1 gm. of ice, therefore the quantity of ice this quantity of heat will melt is

$$\frac{50 \times 365 \times 24 \times 60 \times 60}{3000 \times 80} \text{ or } 6570 \text{ gm.,}$$

or a layer of ice 0.7 cm. in thickness.

192. Diffusivity or thermometric conductivity. It is sometimes necessary to consider the effect of a flow of heat in producing change of temperature in the portion of the material from or to which the flow takes place. In such cases it is convenient to *express the quantity of heat transmitted in terms of the specific heat of unit volume of the substance in which the flow takes place.* If the specific heat of unit mass of a given substance is s and its density is d , the specific heat of unit volume is sd . If k denotes the absolute thermal conductivity of this substance, then the flow of heat, in unit time, across a unit cube of this substance, having unit difference of temperature between its opposite faces, is expressed in the usual thermal units by k , but, if the specific heat of unit volume of the substance be taken as the unit of heat, this flow of heat is expressed by $\frac{k}{sd}$.

This method of considering the flow of heat is analogous to that adopted in studying the diffusion of liquids and gases, and the quantity $\frac{k}{sd}$ is a measure of what Lord Kelvin termed the **diffusivity** of the substance, and may be considered as the coefficient of diffusion of heat. The diffusivity of any substance may evidently be measured by the rise of temperature, produced in a layer of that substance of unit thickness, by the heat transmitted in unit time through a similar layer of unit thickness, having unit difference of temperature between its faces. For this reason diffusivity has been called **thermometric conductivity**, as opposed to absolute conductivity, which for a similar reason has been termed **calorimetric conductivity**.

From what has been said above it will be understood that, during the variable state, when the specific heat of the substance has an influence on the result, the transmission of heat is related to diffusivity, whereas, when the permanent state is attained, only conductivity is involved. For this reason, comparative determinations of the conductivity of substances of different specific heat should be made from data furnished by observations taken during the *stationary state*.

193. Flow of heat across a section of a body perpendicular to the direction of flow. Let us consider the flow of heat through unit area of the plate mentioned in **Art. 190**. Let $ABCD$ (Fig. 137) represent a portion of the plate having its ends $A B, C D$, each of unit area, on the

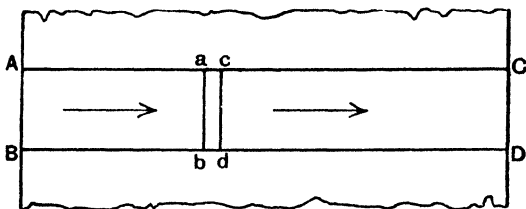

Fig. 137.

two faces of the plate and its sides $A C, B D$, perpendicular to the faces of the plate and therefore parallel to the direction of flow of heat. Mark out $abcd$, a thin layer having its faces ab, cd , perpendicular to $A C, B D$. Then when the permanent stage is reached the flow of heat through this layer is constant wherever it lies in the thickness of the plate; because as its temperature is constant as much heat must be passing out through cd as flows in through ab if we assume that there is no lateral loss of heat.

Let H = the flow of heat in unit time through the layer $abcd$,

O = the difference of temperature between the faces ab, cd , and

x = the distance between the faces ab, cd .

By the second equation* of Art. 191,

$$H = k \frac{\theta}{x}.$$

But H is constant, and so also is k in the majority of bodies, therefore $\frac{\theta}{x}$ must be constant. This means that the temperature gradient is uniform. Hence in the case of a steady flow of heat with uniform temperature gradient the flow across any section in unit time is given by

$$H = k \frac{\theta}{x} \dots\dots\dots (1)$$

where θ now denotes the difference of temperature between any two sections, taken perpendicular to the direction of flow and separated by a distance x , i.e. if T, t , are the temperatures of the two faces A B C D of the plate,

$$H = k \frac{T - t}{AC} \dots\dots\dots (2)$$

A flow of heat of this nature is, however, rarely met with, for it involves that there is no lateral loss of heat, i.e. loss of heat through ac, bd . In cases of conduction such as the flow of heat along a bar heated at one end there is considerable lateral loss of heat by radiation and convection of hot air from the surface of the bar. Thus the heat passing through any cross section of the bar is less and less the further that section is taken from the heated end of the rod. Therefore the temperature gradient is not uniform and the result obtained above in (2) is not applicable.

* The application of this formula involves the assumption, first made by Fourier, that, within very narrow limits, the flow of heat is proportional to the difference of temperature. Starting with this assumption, and the more general one that H is some function of x , it can be shown that, under the conditions here considered, $H \propto \frac{\theta}{x}$; so that the result, though assumed here and in Art. 191, is not essentially an assumption. The general assumption referred to above has been proved, by indirect experiment, to be correct.

Let XY (Fig. 138) represent the bar considered of unit cross section, and $abcd$ a layer of very small thickness δ having a very small difference of temperature τ between its

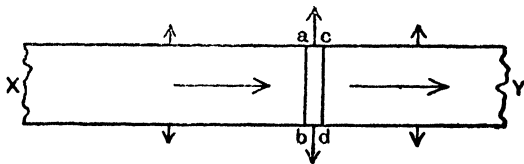

Fig. 138.

faces. Then if τ and δ are small enough the temperature gradient in this layer may be considered uniform, and the result of (1) above being then applicable we have

$$H = k \frac{\tau}{\delta} \dots\dots\dots (3)$$

If now the face cd be made to approach ab until δ , and therefore also τ , become very very small, the lateral loss over ac, bd diminishes, and ultimately the flow of heat across the layer becomes the flow across the section ab , and (3) becomes

$$H = kG, \dots\dots\dots (4)$$

where G is the value of the temperature gradient at ab , i.e. the limit of the ratio $\frac{\tau}{\delta}$, when both τ and δ simultaneously vanish. Thus we get the result

Flow of heat across any section
 = conductivity \times value of the temperature gradient at that section.

The above problems lend themselves to graphical treatment. In the first case the curve between temperature and distance may be represented by the sloping straight line of Fig. 139, obtained by drawing ordinates at A and C equal to T and t , and joining the tops of these ordinates. The temperatures at any intermediate points such as a and c may be obtained by drawing ordinates aP, cQ , at a and c to meet this line. In this case it is evident that $\frac{\theta}{x}$ for any

little slab, $abcd$, is equal to $\frac{aP - cQ}{ac}$, i.e. to $\frac{T - t}{AC}$, i.e. the temperature gradient is the same at all points along AC , and equal to the tangent of the angle the sloping line makes with AC .

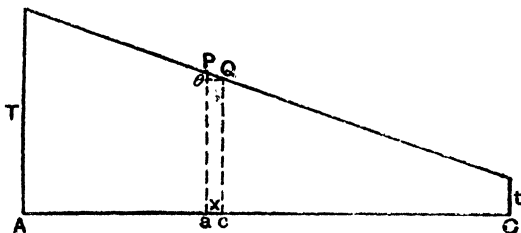

Fig. 139.

In the second case, suppose that the temperatures at X and Y are T at t as before. The temperature curve is now not a straight line, but is a curve. The exact form of this curve can only be obtained by experiment, but is usually somewhat of the shape shown in Fig. 140. Draw ordinates

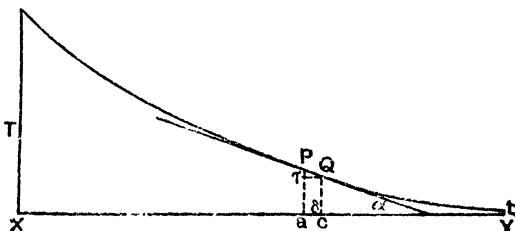

Fig. 140.

aP, cQ , to cut this curve, and join PQ . Let a be the inclination of PQ to XY . The fraction $\frac{\tau}{\delta}$ is equal to

$$\frac{aP - cQ}{ac},$$

i.e. to $\tan \alpha$, and when τ and δ simultaneously vanish the fraction $\frac{\tau}{\delta}$ becomes equal to the tangent of the angle the

tangent of the curve at P makes with X Y, *i.e.* the temperature gradient at any point of the bar is a measure of the tangent of slope of the temperature curve at that point.

194. Simple determination of the temperature gradient curve. Certain chemicals change colour when their temperature is raised to a certain point. Paper which has been impregnated with these chemicals proves very useful in the qualitative study of conduction of heat. This "sensitive paper" turns bright green on being heated and fades again on cooling. The paper may be obtained* in different degrees of sensitiveness, the most sensitive being that which changes colour as low down as 21°C .

Exp. 144. Obtain the temperature gradient curve for a wire heated at one end. Apparatus required: a clean copper wire (No. 16, S.W.G.) about one foot long, a piece

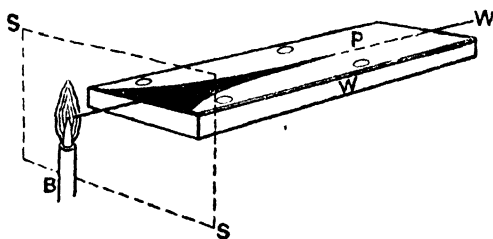

Fig. 141.

of deal about 10 in. \times 5 in. \times $\frac{1}{2}$ in., and a piece of sensitive paper about 10 in. \times 5 in. Place the wire W (Fig. 141) down the middle of the wood with about two inches projecting at one end. Rest the sensitive paper P on the wire, and fasten it down by drawing-pins to ensure good contact between the paper and the wire. Rest the board on a tripod and heat the end of the wire in a steady Bunsen flame. A screen S may be used to protect the sensitive

* From W. B. Nicolson, instrument maker, Glasgow. For fuller details of experiments that may be made with this sensitive paper see *Heat Shadows*, by W. Jamieson (Blackie and Son).

paper from direct action of the flame. Observe the green colouration spreading down the paper immediately over the wire. The width of the coloured portion gradually increases as the wire gets hotter. Finally a steady state is reached, when the coloured patch increases no more in size. Its shape is a double temperature gradient curve.

195. Experimental determination of absolute conductivity. Theoretically it would appear that the simplest method of determining absolute conductivity of a substance would be to determine the quantity of heat transmitted through a plate of the substance of given area and thickness, and having a known difference of temperature between its faces, and then to apply the formula of Art. 191.

This was Peclet's method (see Ex. XIII., No. 7), but it does not give accurate results for two reasons:—

(1) It is difficult, if not impossible, to maintain the two faces at constant *known* temperatures.

(2) It is impossible to avoid **lateral** loss of heat by radiation and convection from the edges of the plate.

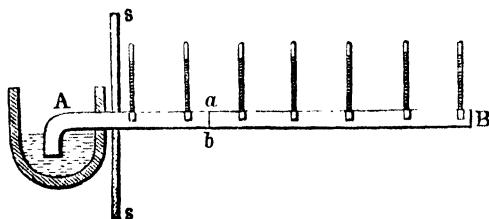

Fig. 142.

On this account the most usual method of investigating conductivity is to take a bar of the substance the conductivity of which is to be determined, and, keeping one end at a high constant temperature, to note the temperature assumed at different points in its length when the permanent state is attained. Forbes was the first who conducted an investigation of this nature in such a way as to obtain results entirely dependent on experimental observation.

In these experiments the bar AB (Fig. 142) had one extremity, A, fixed in a vessel of molten lead, and was

of such length that the temperature of the other extremity, B, was unaffected by the source of heat at A. The screen SS served to protect the bar from radiation from the molten lead. To determine the temperatures at different points in the length of the bar, small holes were drilled into it at equal distances apart, and, after partly filling them up with mercury, the bulbs of small thermometers were inserted; the reading of each thermometer then gave the temperature of the bar, at the centre of the hole in which it was inserted.* Great precautions were taken to keep the end A at a constant temperature, and when the permanent state was attained, as shown by the stationary readings of the thermometers placed along the bar, these readings were carefully observed and recorded.

From the temperature data thus obtained a temperature-distance curve was plotted, and from this curve it was possible to determine the temperature of *any* point on the bar, and by drawing tangents to the curve to determine, as explained above, the temperature gradient at any point. Thus one factor, G , of the formula $H = kG$ was determined.

If, now, H can be determined, we can calculate k . Let us consider what becomes of the heat which flows past the section ab of the bar AB (Fig. 142). The permanent stage having been attained there is no absorption of heat at any point, and it must consequently follow that all the heat passing through ab must be lost by radiation and convection of hot air from the surface of the bar beyond ab , that is, from the surface of the portion aB . If, then, we are able to determine the amount of this radiation and convection from each element of the bar beyond ab , the sum total of this loss of heat will represent the flow across ab .

To make this determination Forbes heated a short bar (similar in all respects, except length, to AB) to a temperature equal to the highest observed temperature on AB , and then carefully observed the rate of cooling. In Art. 96 we have shown how loss of heat can be estimated from rate

* A better method of taking the temperatures is to apply a calibrated thermo-electric junction to each part of the rod in turn.

of cooling if the specific heat is known, and Forbes deduced in this way the heat lost by radiation and convection per second from a unit length of the bar for any given excess temperature (*i.e.* temperature difference between this unit length of rod and the surrounding air). By adding up the amounts of heat lost in this way for each unit length of rod beyond the section *ab* we get the total quantity of heat which has crossed the section *ab*, *i.e.* *H*.

In the equation $H = kG$ we have now got *G* and *H*, and hence *k* can be calculated. It should be noticed that a large number of determinations can be made from the data of the experiment, for we may consider the flow of heat across any number of sections. Further, since each section is at a definite temperature, the value of *k* obtained for any section gives the conductivity of the substance of the bar *at that temperature*, and consequently this method of observation enables us to determine whether *k* varies with the temperature or is constant. Forbes found that in the case of iron the conductivity decreases with increase of temperature, that is, hot iron does not conduct so well as cold iron.

If the conductivity of heat of the material of which the bar is composed is the same at all temperatures, it may be shown by higher mathematics that if the distances of a series of points from the constant high temperature end increase in arithmetical progression, the excess of temperature of the bar at these points decreases in geometrical progression.

Exp. 145. To find the thermal conductivity of india-rubber. Take a flask fitted up as in Fig. 127 and connect a long piece of ordinary indiarubber tubing to the efflux tube. Fit up a rather large calorimeter, as described in the experiments on calorimetry, put in it a known mass of cold water, a thermometer, and a stirrer. When the water is boiling vigorously immerse a length of the tubing into the water in the calorimeter, keeping the tubing well away from the sides of the calorimeter. Stir gently. The temperature of the water gradually rises.

Starting from a temperature five or six degrees below that of the room, take readings of the temperature every

minute until the temperature is about five or six degrees above the temperature of the room. From your readings calculate the rate of rise of temperature when the temperature of the water was equal to that of the air. (This obviates correcting for radiation.) Gently remove the tubing from the water, measure the length, l , of the wetted portion with a millimetre scale, the external diameter, d , of the tubing with a pair of callipers, and the thickness, x , of the wall of the tubing with a screw gauge.

The mean diameter of the tubing is $(d - x)$, and therefore the mean area of the indiarubber interposed between the steam and the water is $\pi (d - x) l$. If θ° C. is the rate of rise of temperature of the water per second at the temperature of the room, t° C. the temperature of the room at this time, *i.e.* the mean temperature of the water during the selected interval, and M the mass of water plus the water equivalents of the calorimeter and stirrer, we have by Art. 191

$$M \theta = k \cdot \pi (d - x) l \cdot \frac{(100 - \theta)}{x},$$

from which k can be found. The value of k is about 0.0004 for ordinary rubber tubing. This is so small compared with the value of k for water (.0013) that difficulty (1) of Art. 195 does not hold, and from the circumstances of the experiment (2) of Art. 195 scarcely exists either.

Exp. 146. Measure the thermo-conductivity of glass. Fit up the apparatus shown in Fig. 143. AB is the tube of glass whose conductivity is required. A certain length of it, CD, is fixed in a jacket tube J, through which steam can be passed. M is a Mariotte's bottle. When the clip L is opened air bubbles through the tube PQ, and the effect of this is that whatever may be the quantity of water in M, the water leaves it at a constant rate. The difference between the readings of the thermometer T in M and the thermometer R in the beaker K gives the increase of temperature of the water due to its passage through the steam jacket. To find the rate of flow of the water K is placed under B for a certain interval of time, and the mass of water that collects is weighed. The beaker K should be screened from the steam tube.

It now remains to get the dimensions of the tube. The length CD is measured by a millimetre scale. The external radius is measured by a pair of callipers or a screw gauge (several readings at different places should be taken). To get the internal radius a measured

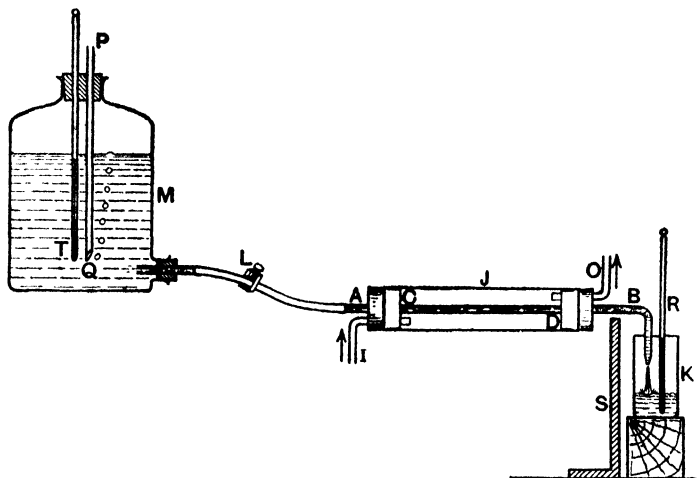

Fig. 143.

length of the tube is filled with water, and this water run into a beaker and weighed. The mass divided by the length gives the area of cross section of the tube, from which the radius of the bore is easily calculated.

Let l = length of CD, the jacket portion of the tube.

r_1 = internal radius.

r_2 = external radius.

$t_1^\circ \text{C.}$ = temperature of water in M.

$t_2^\circ \text{C.}$ = " " " K.

$T^\circ \text{C.}$ = " " the steam.

M = mass of water that collects in K per second.

k = thermal conductivity of glass.

Then to a first approximation the mean temperature of the water in CD is $\frac{t_1 + t_2}{2}$, denote this by $t^\circ \text{C.}$ Also, since the flow of heat is radial, we may, if the wall of the tube is thin, take the area of glass exposed to the heat as the mean between the internal and external areas, i.e. as $\frac{1}{2} 2\pi(r_1 + r_2)l$. Call this A. The thickness of the

wall of the tube is $(r_2 - r_1)$. Applying the equation of Art. 191, we get

$$M(T - t) = k \cdot \frac{A \cdot (T - t)}{r_2 - r_1}.$$

If the wall of the tube is thick so that the ratio $\frac{r_1}{r_2}$ is very far from unity the more correct formula

$$M = \frac{2\pi k l (T - t)}{\log_e \frac{r_1}{r_2}}$$

should be used.

196. Determination of relative thermal conductivity. Forbes' method described in the preceding article may be, and has been, employed for determining the relative conductivities of different metals. The method of reducing the observations is beyond the scope of this work. In all such methods, however, two things must be carefully attended to.

(1) The observations must be made during the permanent state. [Cp. Art. 189 and Exp. 143.]

(2) The surface of the bars must be of the same extent and nature.

This last condition is of equal importance with the first; for the fall of temperature along a bar evidently depends on the rate of loss of heat from its surface; and this depends on the nature and extent of that surface. Wiedemann and Franz, in their experiments on relative conductivity, by

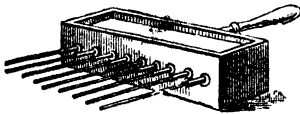

Fig. 144.

the method of the preceding article, employed thin rods of the same size and shape, and electro-plated their surfaces to ensure exact similarity in their nature.

Rough determinations of the relative conductivity of different substances may be made by means of an apparatus due to Ingenhousz, and usually known as **Ingenhousz's apparatus**. This consists of a box (Fig. 144) into which rods of the same thickness, but of different metals, are fixed, as shown in the figure. The ends of the rods pass into the box, and are raised to

a high constant temperature by filling the box with hot water or oil. The portions outside the box are coated with wax, so that, as heat is transmitted along their length, the wax gradually melts. The rods should be of such a length that their far ends are at the temperature of the surrounding air.

During an experiment the bath should be kept at a constant high temperature by means of a burner, and the rods should be protected from direct heating by means of a screen which is, in some forms of the apparatus, attached to the box.

The front plate of the box should be of thick copper and the rods should be made to fit exactly, without corks, into holes bored in this plate.

Instead of coating the rods with wax it is much more satisfactory to place the wax in a narrow longitudinal groove running the whole length of each rod. The greater part of the surface can then be polished or plated so as to secure exact similarity of surface.

When the permanent state is attained the relative lengths along which the melting takes place depend on the conductivities of the metals employed.

To deduce the relative values of the thermal conductivities from the relative lengths of the rods along which the wax has melted, let us consider Fig. 145, which represents two rods AB and CD , along which the wax has melted distances AG and CH respectively. Let us assume, for the sake of simplicity, that AG is twice CH . If T is the temperature of the hot bath and t that of the melting point of wax, the temperature curves will be as shown, the equal ordinates at X and Y representing the temperature of the air surrounding the rods.

Take a cross section at any point E on AB and find the section F on CD which has the same temperature.

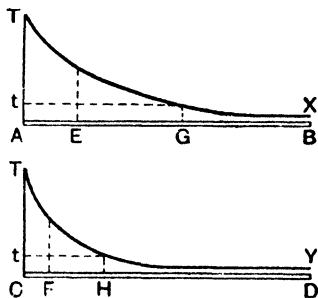

Fig. 145.

Then it is evident that $A E = 2 C F$ and $E G = 2 F H$, and in general that the length of any portion of the rod $A B$ is always twice the length of the portion of the rod $C D$ having its ends at the same two temperatures. Since the heat passing along a rod across any section is lost by radiation and convection from the portion of the rod beyond that section, it follows that the amount of heat which crosses the section E of $A B$ in a given time is twice the amount of heat which crosses the section F of $C D$ in the same time.

Again, since $A G = 2 C H$ the temperature gradient at any section of $A B$ is always half that at the section of $C D$ of the same temperature, *i.e.* the temperature gradient at E is half that at F .

Now apply the formula of Art. 191 to the sections at E and F . Let letters with suffix 1 refer to $A B$ and letters with suffix 2 refer to $C D$. Then

$$\sqrt{H_1} \quad \begin{aligned} H_1 &= k_1 A_1 G_1 t. \\ H_2 &= k_2 A_2 G_2 t. \end{aligned}$$

Now $A_1 = A_2$, and t is the same for the two rods,

$$\therefore \frac{H_1}{H_2} = \frac{k_1}{k_2} \cdot \frac{G_1}{G_2},$$

but

$$H_1 = 2 H_2 \text{ and } G_1 = \frac{1}{2} G_2,$$

$$\therefore 2 = \frac{k_1}{k_2} \cdot \frac{1}{2}$$

$$\therefore \frac{k_1}{k_2} = 2^2,$$

i.e. the conductivity of the substance of the rod $A B$ is four times that of the substance of the rod $C D$.

The above proof may be made quite general. If the length of the melted wax on $A B$ is n times that of the melted wax on $C D$ we have, as above,

$$H_1 = n H_2 \text{ and } G_1 = \frac{1}{n} G_2,$$

and therefore

$$\frac{k_1}{k_2} = n^2,$$

i.e. the conductivities are as the squares of the lengths along which the wax has melted.

Exp. 147. Compare the thermal conductivities of different metals by Ingenhousz's method, using sensitive paper as the temperature indicator. Work as in Exp. 144, using now two or more polished wires W_1, W_2, W_3 (Fig. 146), of different metals, but of the same dimensions, resting under the same sheet of sensitive paper and with their ends close together in the same part of the Bunsen flame. Heat till the steady state is reached and the coloured patches have ceased to increase in size. Remove the Bunsen and then measure

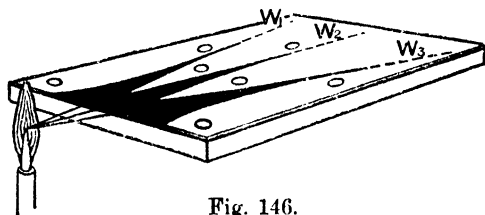

Fig. 146.

the distances from the common ends of the wires to the ends of the coloured patches. If these lengths are l_1, l_2, l_3 , for the wires W_1, W_2, W_3 , and if k_1, k_2, k_3 , are the thermal conductivities of the metals composing these wires, we have $k_1 : k_2 : k_3 :: l_1^2 : l_2^2 : l_3^2$.

Example. In such an experiment the distance between the end in the Bunsen flame and the other end of the coloured patch was 10·0 cm. for copper, 5·6 cm. for brass, and 4·0 cm. for steel. Compare the thermal conductivities of copper, brass, and steel.

We have

conductivity of copper : conductivity of brass : conductivity of steel
 $:: 10\cdot0^2 : 5\cdot6^2 : 4\cdot0^2$, *i.e.* as 100 : 36 : 16.

197. It may be remarked here that if the metals are arranged in the order of their conductivities for heat and also in the order of their conductivities for electricity, the two lists will be found to contain the metals in much the same order, thus showing a close connection between thermal and electrical conductivities.

198. Conductivity of liquids. The determination of the conductivity of fluids is very difficult for three reasons :

1. Convection currents have to be avoided.
2. From their nature, fluids have to be enclosed in vessels, and the conduction by the walls of the vessel interferes with the result.
3. Their conductivity is very low.

The conductivity of all liquids, except mercury and other liquid metals, is very low. For this reason it is difficult to exhibit conductivity in a liquid experimentally, and the difficulty is increased by the influence of convection currents and by the conduction of heat through the walls of the containing vessel. If, however, a liquid is heated from *above* convection currents are not produced, and the conduction through the walls of the containing vessel may be made negligibly small by using thin vessels of badly conducting material. The following experiments illustrate the low conductivity of liquids.

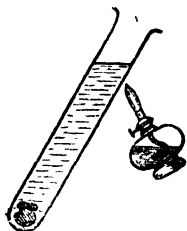

Fig. 147.

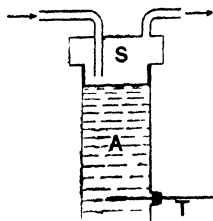

Fig. 148.

Exp. 148. Load a piece of ice by twisting a piece of copper wire round it, and sink it in a long tube nearly full of water (Fig. 147). Fix the tube in an inclined position on a retort stand, and heat it near the top by a spirit lamp. It will be found that the water at the top will boil before much of the ice is melted.

Exp. 149. Fit a tall jar, A, made of wood or glass, with a steam-box, S, and a thermometer, T, as shown in Fig. 148. Fill the jar with water or other liquid so that the top layer of the liquid is in contact with the lower part of the steam-box. When steam is passed through the box the top layers become heated, and heat should travel downwards through the liquid towards the bulb of the thermometer T. It will be found that even for comparatively small depths the rise of temperature indicated by the thermometer is very small. If the experiment be performed with mercury in the jar, a very considerable rise of temperature will be observed.

Despretz investigated the conductivity of water by a method similar to that used by Forbes for rods of metal,

The essential parts of the apparatus he used are shown in Fig. 149. A B C D is a wooden cylinder, containing water, and having thermometers fitted into its sides. A current of hot water at constant temperature was passed through the metal pan, P P, which rests on the surface of the water in A B C D.

After an interval of more than 24 hours it was found that the permanent state had been attained. The rest of the experiment was then carried out as described in Art. 195.

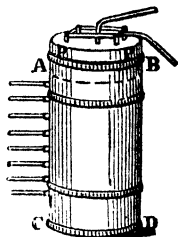

Fig. 149.

Exp. 150. Fill an envelope with water, and hold it in a gas flame. The water may be heated to boiling. The heat is conducted through the paper and carried away by convection in the water sufficiently rapidly to prevent the paper being scorched.

199. Conductivity of gases. The conductivity of gases is extremely low. Still, the fact that they do conduct is shown by the following experiment.

Exp. 151. Arrange to throw the shadow of a red-hot poker on a screen. Notice how the heating of the air above and below the poker is indicated on the screen. (Explain the indications.) Note that the heating extends but a very little way downwards, showing that air is a bad conductor of heat. In this experiment convection masks the true conductive effect, for as soon as a portion of air below the poker gets hot it becomes less dense and rises.

In a mass of gas uniformity of temperature is established more quickly by convection than in a mass of good conducting material by conduction.

The very low conductivity of cotton-wool, eiderdown, felt, and other fabrics of open texture is due very largely to the air enclosed in the fabric.

In the determination of the thermal conductivity of gases the difficulties referred to above for liquids are met with to such a degree, that the direct determination of the thermal conductivity of a gas is impossible.

Some indirect determinations have, however, been made from observations of the rate of cooling of a body in a gas, under such conditions as to eliminate the effect of convec-

tion. We are already familiar with the fact that the cooling of a body depends on the conductivity of the substance surrounding it, hence we can understand that the rates of cooling of a hot body, *in vacuo*, and when surrounded with gas, will be different, and that, if convection have no influence on the result, this difference will depend on the conductivity of the gas.

Exp. 152. Fit a piece of platinum wire about 20 cm. long into a wide glass tube as shown in Fig. 150. Exhaust the tube and pass a current through the wire until of sufficient strength to make the wire glow brightly. Now admit air into the tube and pass the same current. The glow is less, showing that the heat is being conducted away from the wire by the air. Ex-

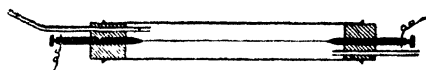

Fig. 150.

haust the tube again and fill with hydrogen. Again pass the same current. The wire now refuses to glow at all, thus showing that hydrogen is a much better conductor of heat than air. (As a matter of fact the conductivity of hydrogen is seven times that of air.)

TABLE OF CONDUCTIVITIES.*

Substances.	Relative Conductivity.	Absolute Conductivity k C.G.S. units.
Silver	100.0	1.527
Copper	73.6	1.000
Gold	53.2	.723
Brass	23.6	.321
Zinc	19.0	.258
Tin	14.5	.197
Iron	11.9	.164
Steel	11.6	.158
Lead	8.5	.115
Platinum	8.4	.114
Bismuth	1.8	.024
Water (15° C.) .		0.0014
Ice		0.005
Oak		0.0006
Air		0.000057
Indiarubber . .		0.0004

EXERCISES XIII.

1. A piece of thin paper is wrapped round a rod which is composed partly of metal and partly of wood. On holding the rod in a spirit flame the paper is charred where it covers the wood, but not where it covers the metal. Explain the cause of this.

2. Explain the use of the wire gauze surrounding the flame in the lamp used in coal-mines.

3. The bulb of a delicate thermometer is immersed at a slight depth below the surface of water. The upper surface of the water is heated, and the thermometer is hardly affected. On heating the water from below, the thermometer shows an immediate rise of temperature. Explain these two results.

4. Find the quantity of heat that will be transmitted, in 1 hour, across a plate of copper 1 sq. metre in area and 5 cm. thick, the difference between the temperatures of its faces being 10°C . The absolute conductivity of copper is 0.72.

5. It is found that 9,150,000 gramme-degrees of heat are transmitted, per minute, across a sheet of silver, 100 sq. cm. in area and 1 mm. thick, with a difference between the temperatures of its faces of 100°C . Find, in C.G.S. units, the conductivity of silver.

* 6. Peolet has stated that the quantity of heat which passes, in an hour, through a plate of lead 1 sq. metre in area and 1 cm. thick, with a difference of 1°C . between the temperature of its surfaces, is 1383 kilogramme-degrees. What value does this give for the absolute conductivity of lead in the C.G.S. system?

7. The absolute conductivity of silver in C.G.S. units is 1.5; how many heat-units will pass, per minute, across a plate of silver, 1 metre long, 1 metre broad, and 5 cm. thick, when its opposite faces are kept at temperatures differing by 100°C .?

8. The thermal conductivity of felt in C.G.S. units is 0.000087; find the quantity of heat that is transmitted, in one hour, through a layer of felt 1 cm. in thickness and 20 sq. cm. in area, when its opposite faces are kept at temperatures differing by 20°C .

9. A square metre of a substance, 1 cm. thick, has one side kept at 100°C ., and the other, by means of ice, at 0°C . In the course of 10 minutes one kilogramme of ice is melted by this operation. Calculate the conductivity of the substance, assuming the latent heat of water to be 80.

10. Express the conductivity of copper in units involving the pound, foot, second, and degree Fahrenheit.

CHAPTER XIV.

RADIATION.

200. Nature of radiation. As we have already mentioned in Art. 183, radiation is different from conduction and convection. Heat is said to pass by radiation when it is transmitted from one body to another, through a vacuum, or through an intervening material medium without affecting the temperature of the medium. The heat of the sun reaches us by radiation, as does also the warmth we experience when we stand before a fire. A thermometer suspended in a vessel from which the air has been exhausted receives heat from external objects; which shows that the presence of air is not necessary to the passage of heat by radiation. Again, a piece of black cloth, if exposed to the rays of the sun on a frosty day, becomes much warmer than the surrounding air. This shows that heat is able to pass through a medium like air without warming it nearly so much as it does some object which is in the medium or beyond it.

Other gases besides air have been found to readily allow the passage of heat by radiation. The drier a gas is the more readily does heat traverse it by radiation. It was mentioned that heat travels through a vacuum, and experiments have shown that it does so better than through the driest air.

Many solids and liquids allow radiant heat to pass through without being themselves warmed to any great extent: *e.g.* rock salt and bisulphide of carbon. Other bodies, such as wood, slate, metal, etc., do not permit its passage; they absorb the energy, and therefore become heated.

Various experiments have proved that radiant heat is transmitted in the same way as light. In the first place, most bodies which are transparent to light are more or less transparent to "radiant heat." Again, the speed with which heat is radiated from hot bodies is the same as that with which light travels from luminous bodies. In a total eclipse of the sun, for example, both heat and light are cut off simultaneously. Also, heat is reflected from polished surfaces, and the laws of its reflection are the same as in the case of light. It is also refrangible, and can thus be brought to a focus by a lens. The use of a simple lens as a burning-glass shows that the heat which has passed through the lens is concentrated at about the same spot as the rays of light.

Since heat is radiated from one body to another through a vacuum, and as the radiation of heat bears so many analogies to the passage of light, it is believed that both are transmitted by means of the undulations of the ether. As we use the term *rays of light*, so we may speak of *rays of heat* in a similar sense.

The molecules of a white-hot body are in a state of rapid vibration, the frequencies of vibration being very different for molecules of different substances and for the same molecules at different temperatures. These moving molecules disturb the ether around them and send waves of disturbance through it. The velocity with which these waves travel through the ether is the same. All waves, whatever their frequency, warm bodies when they are absorbed. The most familiar hot bodies, including the sun, send out most energy in vibrations of lower frequency than visible light. If the body is black like lampblack it absorbs all the incident radiation, and hence the energy of all the waves is spent in heating the body. The several properties of the waves which depend more or less upon the frequency are, however, more fully described in text-books of Light.*

A better term for *radiant heat* is *radiant energy*, but the word radiant itself is not a very good word, for it implies the existence of radii or rays along which energy is transmitted, whereas we now believe energy is transmitted in spherical or circular waves, just as the waves of disturbance in a pond of water in which a stone is thrown travel out in ever-enlarging circles.

* See Stewart and Satterly's *Light*, Art. 112.

We shall, however, use the term radiant heat for waves of low frequency that do not excite vision. Another name is infra-red rays, as these rays are refracted by a prism to a less extent than the red rays.

When a body is first heated it sends out waves of low frequency (or long wave-length). As the heating is continued waves of higher frequency are added to these, and the waves added just when the temperature rises as far as 500° C. are just quick enough to excite in our eyes the sensation of red light. As the heating is continued still further waves which excite the sensations of orange, yellow, green, blue, and violet light are successively added to the other waves, so that the colour of the body gradually changes, the waves exciting the violet sensation being added at about 1400° C. The body now appears white-hot. Further heating does not alter the colour so much, but enables the body to send out waves of very high frequency which have intense chemical and electrical effects. These very high frequency waves are called actinic or ultra-violet waves. They are refracted by a prism more than the violet waves. All these waves carry energy, and have an equal claim to the title of Radiant Heat. But this name is sometimes given specially to the infra-red rays because these carry such a large proportion of the heat emitted by such sources as a coal fire; and the whole emitted by hot water, etc.

201. The behaviour of bodies towards radiant heat.

When radiation is incident on the surface of any medium, it is, in general, split up into four parts, viz. :—

1. A portion which suffers regular reflection at the surface of the medium in accordance with the ordinary laws of reflection.

2. A portion which suffers reflection at minute irregular portions of the surface. This is called diffusion.

3. A portion which is refracted into the medium in accordance with the laws of refraction.

A part of this is

(a) transmitted by the medium; and the other portion is

(b) absorbed by the medium.

If the total quantity of incident radiation be represented by unity, and the quantities reflected, diffused, transmitted, and absorbed be respectively r , d , t , and a , then we have

$$r + d + t + a = 1.$$

The quantities in the left-hand expression are essentially positive; and it is therefore evident, from the relation given,

that if one of these quantities be large—nearly equal to unity—then the others must be small. For example, if $r = 0.9$, then d , t , and a must be each less than 0.1. That is, if the reflecting power of the surface of a medium be very great, then its powers of diffusion, transmission, and absorption are small. Further, it is evident that any one, or the sum of any two or three, of these quantities may be equal to unity, and thus the remaining quantities or quantity must vanish. That is, the incident radiation may, for example, be entirely absorbed by a medium, or completely reflected and diffused at its surface.

Hence, if the reflection, diffusion, transmission, and absorption of radiation be taken as established by experiment, we may, without further experiment, state that, if any medium exhibit any one or more of these properties in a marked degree, it must exhibit the others in a proportionately smaller degree.

It is now the function of experiment to analyse each of the above phenomena; in so doing it is necessary, in each case, to determine—

1. The general laws of the phenomenon.
2. The properties of different media in relation to the phenomenon.
3. The influence of the surface of the medium.
4. The influence of the nature of the source of heat from which radiation takes place.

We shall now briefly indicate the methods and results of experimental investigations carried out in this way.

202. Instruments used in experiments on radiation. Previous to the time of Melloni, the great difficulty in the experimental study of radiation lay in the fact that there was no instrument sufficiently sensitive to radiation to be of any use in accurate experiments.

Leslie obtained fairly satisfactory qualitative results with his differential thermoscope, described in Art. 79. This instrument was largely used in the early days of the study of radiation.

The modern form of this instrument as adapted for the study of radiant heat is shown in Fig. 151. It comprises

two bulbs connected by a bent capillary tube and containing ether and ether vapour. The lower bulb is coated with lampblack.* When radiant heat falls on the lower



Fig. 151.

bulb its temperature rises and the vapour pressure of the ether is increased; as a consequence the ether rises in the tube leading to the upper bulb. The greater the quantity of radiant heat falling on the lower bulb the greater the rise of temperature, and consequently the higher the ether rises, and this height can be read off on a scale placed behind the capillary tube. Owing to external changes of temperature the quantitative results obtained with this instrument are not very reliable.

Modern experimenters have used the thermopile, which was first invented by Nobili, and afterwards improved by Melloni and others. This instrument consists † of a number of short square rods of bismuth and antimony, arranged alternately side by side, so as to form a bundle having a square cross section. At the opposite ends of this bundle are the alternate junctions of the bismuth and antimony rods, so that if one end is heated a thermo-electric current is produced.

To employ this instrument as a thermometer it is connected up with a reflecting galvanometer, as shown in Fig. 152, and one end of the bundle of bismuth and antimony elements is then exposed to the radiation. The absorption of heat by this end produces a current which deflects the galvanometer needle. Since the thermal effects involved are very small, this deflection may be taken as proportional to the heat absorbed by the exposed end of the pile. If this end is covered with a substance which absorbs an equal proportion of all kinds of radiation, then the galvanometer indication is proportional to the intensity of the incident radiation. We shall see later that

* Lampblack is the best radiator and absorber of radiant heat. See Arts. 213, 215.

† See Stewart: *Higher Text-Book of Electricity and Magnetism*, Art. 213.

lampblack absorbs every kind of radiation to the same degree. This substance is therefore employed to cover the ends of the thermopile.

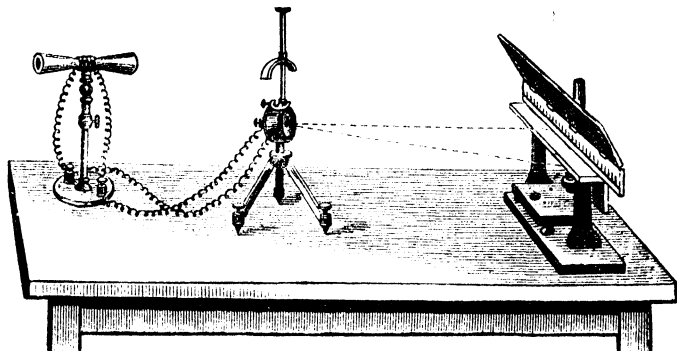

Fig. 152.

As a source of radiant heat we may use a cubical tin can containing boiling water. To increase the radiating power as much as possible one face of the can should be coated with lampblack (Art. 213). This cube is usually termed a Leslie's cube.

203. Propagation and transmission of radiation. The velocity of radiant heat and light through vacuo is the same, while the velocity of radiation of any particular wave-length through any body is inversely proportional to the refractive index of the body for that particular radiation.*

An experiment to show that radiant heat and light travel at the same speed can be performed at the time of a total eclipse of the sun. Direct a thermopile to the position of the sun and wait until it emerges from behind the moon. Observe the galvanometer at the moment the sun shows itself. The needle is immediately deflected, showing that the heat and light take the same time to travel from the moon to the earth.

* See Stewart and Satterly : *Light*, Arts. 132, 133.

Exp. 153. To show that radiant heat travels in straight lines. Take two screens of wood A B and C D (Fig. 153) and bore a small hole (say, 5 cm. in diameter) through each. Arrange them parallel to each other, and opposite the hole in A B place the source of heat H (a Leslie's cube) with the blackened face turned towards A B.

The thermopile T and its attachments are then placed on the far side of C D, the face of T being towards C D.

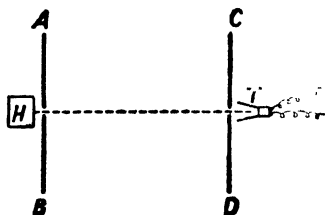

Fig. 153.

T is now moved about. In general, no deflection of the galvanometer will be observed. If, however, T is placed in the same straight line as the holes in the screens the galvanometer needle will be largely deflected.

A body which transmits nearly all the radiant heat which is incident on it is said to be **diathermanous**.* A body which absorbs nearly all the incident radiant heat is said to be **adiathermanous**.† It follows from a consideration of the energy of the radiation that the passage of radiant heat through a body does not raise its temperature if the body is perfectly diathermanous, but does raise it if the body is adiathermanous.

204. The law of inverse squares. The law which governs the decrease of intensity of radiation with distance is the same as that for light, the two cases being identical.‡ The intensity at different distances from the source of radiation is inversely proportional to the square of the distance. This may be proved experimentally by means of the arrangement shown in Fig. 154. A thermopile fitted with a reflecting cone is placed in front of a blackened large tin vessel (75 cm. × 75 cm. × 10 cm. is a convenient size) containing boiling water. If the thermopile is kept facing

* Greek, *dia*, through; *thermos*, heat.

† Greek, *a*, negative; *dia*, through; *thermos*, heat.

‡ See Stewart and Satterly: *Light*, Art. 14.

the vessel and moved about along a line perpendicular to the vessel, it is found that as long as the cone produced by the prolongation of the cone of the thermopile wholly cuts the front of the vessel the indication of the galvanometer remains unaltered.

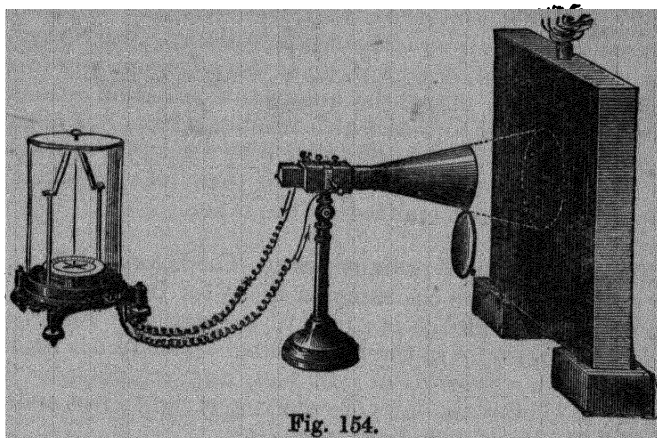

Consider two positions, A and B, of the thermopile distant x and y respectively from the vessel. It follows by geometry that the areas of the circles from which radiation is received in the two cases are as x^2 to y^2 . Since the galvanometer deflection remains unaltered, the influx of radiation into the thermopile is the same in the two cases, and

$$\therefore \frac{\text{the intensity of the radiation at the position A from a small area of the vessel}}{\text{the intensity of the radiation at the position B from the same area of the vessel}} = \frac{y^2}{x^2}$$

i.e. the intensity of radiation at a point due to a small radiating area is inversely proportional to the square of the distance of the point from the area.

Further, if the surface of the vessel inclined at any angle to the axis of the thermopile, the indication of the galvanometer will not change. This proves that the intensity of the radiation from any surface in any direction is proportional to the cosine of the angle which this direction makes with the normal. For, if the normal to the surface

is inclined to the axis of the thermopile at an angle θ , then the area from which the pile receives radiation is increased in the ratio $\cos \theta : 1$, and therefore, since the deflection of the galvanometer is unaltered, it follows that the intensity of this radiation decreases in the ratio $1 : \cos \theta$.

By application of these two laws—the law of inverse squares and the *cosine law*—it can be shown, geometrically, that if two bodies, A and B, of equal radiating power are placed near each other, the amount of radiation reaching A from B is equal to that which reaches B from A. Hence, when dealing with the radiation between any two bodies, the radiation received by any one of them may be taken as proportional to that emitted by the other.

205. Reflection of radiant heat. The laws of reflection for radiant heat are the same as those for light. That is, the angle of incidence is equal to the angle of reflection, and both angles lie in the same plane. This fact is readily illustrated by experiment; in fact, any arrangement intended to exhibit the laws of reflection of light gives exactly similar results with radiant heat.

Exp. 154. Prove that when radiant heat is reflected at

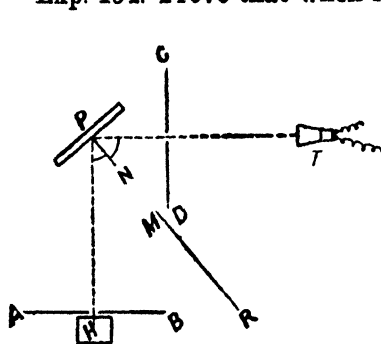

Fig. 155.

a polished surface the angle of incidence is equal to the angle of reflection. As a reflector use a flat polished tin-plate P arranged as in Fig. 155. Place the source of heat H, a screen M R, and the plate P in position, and move the thermopile T about. In some positions the galvanometer needle will be reflected showing that T

is receiving heat. The screen M R stops direct transmission from H to T. Hence the only conclusion is that heat is reflected at P,

To show that the angle of incidence is equal to the angle of reflection take the two screens mentioned above, and place A B in such a position that the incident ray H P is inclined about 45° to the plate P. Move C D and T about till the galvanometer deflection is a maximum. Join up H P and T P, draw the normal P N and show that the angles H P N and T P N are equal.

The following is another common experiment:—

Exp. 155. Set up two large concave mirrors, M, M' (Fig. 156), facing each other, and about 3 feet apart, with their axes in the same straight line. At the principal focus, F', of one mirror, say, M', support the bulb of a small air thermometer. At the principal

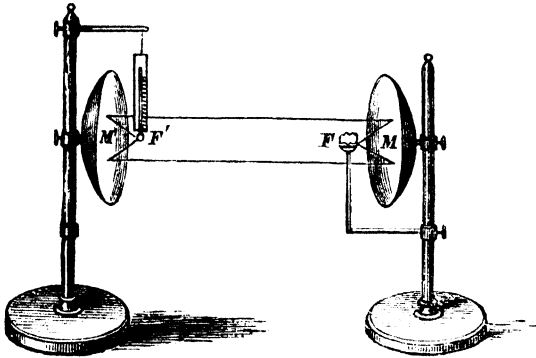

Fig. 156.

focus F of the mirror M place an iron ball heated to a red heat. The thermometer shows a rapid rise of temperature as long as the bulb is kept at F', but if moved into any other position the temperature immediately falls, thus showing that the radiation from the iron at F is first reflected from M on to M' and then converged to F'. The result is not affected by placing a small screen between F and F' to prevent the thermometer being influenced by direct radiation from the iron.

Vary the experiment by placing a piece of phosphorus at F'. If the iron ball is sufficiently hot, the phosphorus quickly takes fire.

206. Reflecting Power. The *reflecting power* of a surface is measured by the ratio of the amount of regularly reflected radiation to that of the incident radiation. For example,

if the radiation incident on a surface be denoted by R , and the quantity reflected by Rr , where r is less than unity, then the reflecting power is measured by the ratio

$$\frac{Rr}{R} = r.$$

This subject was first investigated by Leslie, who employed the apparatus shown in Fig. 157. H represents a Leslie's cube, M is a concave spherical mirror, so placed relative to H that the focus of the reflected radiation is at F . The surface whose reflecting power is to be tested is placed at SS' in such a position that it intercepts the

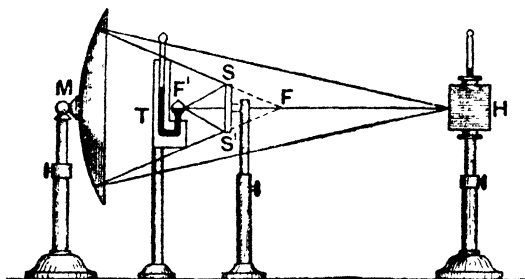

Fig. 157.

radiation converging to F , and reflects it to F' , where one of the bulbs of the differential thermoscope, T , is placed. With this arrangement the *relative* reflecting power of different surfaces may be determined by noting the indications of T as the surfaces are successively placed at SS' . This was the method Leslie adopted; and from his observations he drew up a table exhibiting the relative reflecting powers of a number of different surfaces for the specific radiation used.

LESLIE'S TABLE OF REFLECTING POWERS OF SURFACES FOR RADIATION FROM A BODY AT 100° C.

(*BRASS is taken as 100.*)

Brass.....	100	Steel	70
Silver	90	Glass	10
Tin.....	80	Lampblack	0

Leslie's method was not very accurate, and moreover does not determine reflecting power as defined above. Had he first placed his thermometer at F, and compared its indication in that position, before the interposition of a plate at SS', with its several indications at F', then the ratio in each case would have given an approximate determination of what may be called the *absolute* reflecting power of each surface.

More recent workers have used apparatus similar to that shown in Fig. 155, in which the angle of incidence may be varied. The plate being removed, the thermopile T was first placed along HP produced, and the incident radiation from H measured. The plate was then placed in position and the thermopile rotated to catch the reflected ray, the total length of path from H to T being kept the same as before.

The following is a brief summary of the results of experiment:—

1. The general laws of reflection of radiant heat are the same as those of light.
2. The reflecting power of any surface increases with the degree of polish of that surface.
3. For *diathermanous* substances the reflecting power increases with the angle of incidence, but for metallic surfaces it remains nearly constant up to about 70°. Above this limit the reflecting power gradually *decreases*. *These results are also true for light.*
4. The reflecting power of a surface varies with the nature of the source of radiant heat.

Polished metals are the best reflectors. Roasting screens, firemen's helmets, and the reflectors of gas-stoves are familiar applications of the principles governing the reflection of heat.

207. Diffusion of radiant heat. When radiation is incident on a rough or unpolished surface, it is, as it were, broken up by the inequalities of the surface, and undergoes irregular reflection or diffusion.

The **diffusive power** of a surface is determined by the ratio of total quantity of diffused radiation to the quantity of incident radiation.

Melloni exhibited the existence of diffusion by means of the apparatus of Fig. 155. The roughened surface to be experimented on was placed at P, and the thermopile adjusted in the position T. In this and similar positions the thermopile indicated at once the absorption of radiation by the face turned towards P. This radiation could not be *reflected* from the surface at P, for that surface was not polished, and the effect was observed for *all positions* of P in front of the plane of the surface. The effect could therefore be due only to diffusion, or to radiation from the surface heated by direct radiation from H.

Melloni showed that the effect could not be wholly due to this latter cause. For (a) the indication of the thermopile was instantaneous, and reached its maximum at once; whereas, if the radiation from H was first absorbed by the surface and then radiated to T, time would be required for the effect to become appreciable, and the maximum would be attained slowly; (b) the radiation incident on T is of the *same nature* as that coming from H, and *different* from that which would be radiated by the surface.

The diffusive power of any surface may be determined by the same method as that adopted for the determination of reflecting power; but the observations must be quickly taken, or they may be complicated by the effects of radiation from the surface.

The following is a summary of the results obtained by recent workers:—

1. The heat diffused in any direction from a given surface varies with the inclination to the surface.

2. The diffusive power of a surface varies with the nature and material of the surface. In general a rough, uneven surface, such as that of a fine powder, diffuses best; but this depends upon the *absorbing* power of the material of the surface. For example, a rough lampblack surface would *absorb* more than 90 per cent. of the incident radiation, and diffuse less than 10 per cent.

3. The diffusive power of a given surface varies with the source of heat. In general radiation of low refrangibility tends to be absorbed, while radiation of higher refrangibility

tends to be diffused. For example, a white lead surface absorbs about 90 per cent. of the radiation from a source at 100° C., and diffuses about 10 per cent.; but it absorbs only 18 per cent. of solar radiation, and diffuses 82 per cent.

208. Refraction of radiant heat. The laws of the refraction of radiant heat are identical with those of optical refraction. This can be shown by the following experiment.

Exp. 156. To show that radiant heat obeys the laws of refraction. Arrange the usual apparatus for obtaining a pure spectrum,* using a strip of platinum heated to incandescence by a Bunsen flame or an electric current as the source of light and heat. Adjust the face of a thermopile so as to receive the portion of the spectrum lying below the red; the galvanometer at once indicates the absorption of heat. Now rotate the prism so as to displace the spectrum some distance on either side of the pile; the galvanometer deflection quickly falls to zero.

Again place the pile in the same position as before, relative to the visible spectrum; the deflection will again increase to something near its original value. Again, with the thermopile in position, allow the platinum to cool slowly; the deflection shows a slight continuous decrease as the visible spectrum gradually fades out from the violet to the red end; but soon after this point is reached a much more marked decrease is observed, indicating that the radiation incident on the pile is, in its turn, disappearing.

Experiment 156 and others of a similar character show that both the luminous and non-luminous radiation from an incandescent source of heat are refracted according to the same general laws, and also that the *refrangibility** of the non-luminous portion of the radiation is lower than that of the luminous portion. *Rock-salt* prisms and lenses should be used in the experiments, for glass absorbs a large percentage of the non-luminous radiation, while rock-salt absorbs less than 10 per cent. of it. (See Table, p. 336.)

* See Stewart and Satterfly: *Light*, Arts. 102, 103.

209. Measurement of Diathermancy. The proportion of the incident radiation transmitted by a given thickness of a substance is a measure of the *power of transmission* or *diathermancy* of that thickness of the substance for the radiation considered.

Exp. 157. Determine the diathermancy of different substances. Set up apparatus as indicated in Fig. 158 (*Melloni's method*).

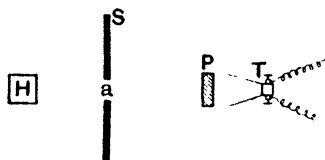

Fig. 158.

H is the source of heat; S a screen, with a circular aperture; *a*, through which radiation from H falls on P, the plate of the substance to be tested. Place the thermopile at T and note the galvanometer deflection before and

after interposing the plate P. The ratio of these deflections determines the diathermancy of the substance for the thickness considered. Repeat with plates of other substances of the same thickness.

Melloni measured the diathermancy of many solids and liquids. Some of his results with solids are expressed in the following table. The figures are the percentages of radiation transmitted by plates 2.5 cm. thick for the four sources of radiation mentioned at the head of the table:—

Substance.	Oil Flame (Argand lamp without chimney).	Incandescent Platinum, heated by spirit lamp.	Blackened Copper, heated to 390° C.	Blackened Copper, heated to 100° C.
Rock-salt (clear) ...	92	92	92	92
Iceland spar ...	39	28	6	0
Mirror glass ...	38	25	6	0
Quartz (clear) ...	37	28	6	0
Amber (artificial) ...	21	5	0	0
Borax ...	18	12	8	0
Alum (crystals) ...	9	2	0	0
Ice ...	6	0	0	0

In this table it will be noticed that with all bodies except rock-salt the diathermancy increased with the temperature of the source of radiation. This is not always true. It depends on the nature of the rays emitted. Thus glass will transmit a greater proportion of the rays from a piece of incandescent platinum heated in the flame of a spirit lamp than from the flame itself, although the platinum cannot be as hot as the flame.

Melloni also examined the diathermancy of a body for the radiation transmitted by another body, and found that a body is very diathermanous to radiation which has already passed through a plate of the same substance. Thus (see table, p. 336) alum only transmitted 9 per cent. of the radiation from a naked flame, but he found that when the radiation had already passed through an alum plate $\frac{1}{16}$ in. thick 90 per cent. of it was transmitted.

In the case of liquids narrow cells of very thin glass were employed, and indications were taken first with the radiation passing through the empty cell, and then with the radiation passing through the same cell filled with the liquid to be tested.

Some of Melloni's results are given in the following table. He used an Argand burner as his source of radiation, and it must be remembered that the rays had to pass through glass both before and after traversing the liquid. The liquid thickness was about 1 centimetre.

	Percentage Transmitted.
Cell alone	Taken as 100.
Cell containing :—	
Block of mirror glass, 1 cm. thick	53
Carbon bisulphide	63
Essence of turpentine	31
Pure sulphuric acid	17
Absolute alcohol	15
Alum water	12
Distilled water	11

A solution of iodine in carbon bisulphide though opaque to light was found to be very diathermanous to radiant heat. It is worthy of note that although alum is usually considered adiathermanous, yet the addition of alum to water raises the diathermancy of the latter.

The facts given above are sometimes applied to determine roughly the nature of radiation. For example, if the radiation considered is incapable of transmission by alum, then it must consist entirely of dark heat waves.

Exp. 158. To compare the diathermancies of water and carbon bisulphide. Focus the sunlight upon the bulb of an ordinary thermometer, and place between the bulb and the lens a flat glass cell filled with water. Observe the reading of the thermometer, and then replace the cell by a similar one filled with bisulphide of carbon. Note that the temperature indicated by the thermometer is higher in the second case, thus showing that the bisulphide is more diathermanous than water. If a little iodine be now dissolved in the bisulphide, it becomes opaque to light, but is still very diathermanous, thus proving that a body which is non-transparent to light may be transparent to heat.

Tyndall studied the diathermancy of *gases* by enclosing them in a long wide tube with rock-salt ends. A thermopile was placed near one end of the tube, and the source of heat at the other end. To render the arrangement more sensitive, a compensating source of heat was employed. This was a cube filled with hot water, and placed in such a position relative to the pile as to exactly balance the effect of the radiation from the principal source of heat, when the interior of the tube was a vacuum.

When different gases were admitted into the tube, the galvanometer needle was deflected from its position of equilibrium, and the amount of deflection varied with the nature of the gas. It was found that simple gases were more diathermanous than compound gases, and that the diathermancy of dry air was greatly decreased by the presence of various vapours. Water vapour, for example, has a very marked effect, and, according to the amount present, was found to increase the absorptive power to from 30 to 70 times that of dry air. Carbon dioxide also exerts an absorbing effect,

210. Influence of thickness on transmission and absorption. The influence of thickness on diathermancy was investigated by Jamin and Masson. They deduced from their experiments that when radiation of a definite kind is transmitted through a substance the amount transmitted decreases in geometrical progression as the thickness increases in arithmetical progression—that is, each layer of the substance, of a given thickness, transmits the same proportion of the radiation which enters it.

Thus, if q denote the quantity of radiation entering the substance, then the quantity present after traversing unit thickness is qa , where a is a constant which is less than unity. Similarly, on transmission through another layer of unit thickness, the quantity of radiation is reduced to qa^2 ; and therefore, after transmission through a thickness of n units, the quantity of transmitted radiation is given by qa^n . The constant a has been called the **coefficient of transmission**.

When radiation of a compound nature is transmitted by any substance, its various constituents are absorbed to different degrees, and thus the nature of the transmitted radiation is subject to continuous change. The character of this change is, however, such that the nature of the transmitted radiation tends to become constant and capable of transmission without absorption. For this reason radiation which has passed through a plate of any substance passes readily with little loss through another plate of the same substance. (See mention of alum, Art. 209, p. 337.)

Example. A plate of rock-salt 2.5 mm. thick allows 93 % of the incident radiant heat to pass through it. How much will a plate four times as thick transmit? Assume that there is no loss by reflection at the surfaces. Find also the coefficient of transmission of rock-salt.

Then	93 % gets through one plate,
93 % of 93 %	„ „ a plate twice as thick,
93 % of 93 % of 93 %	„ „ a plate three times as thick,
93 % of 93 % of 93 % of 93 %	„ „ a plate four times as thick,
	i.e. 1 cm. in thickness.

This is equal to about 75 %, i.e. therefore the coefficient of transmission is .75.

211. Newton's law of cooling. Consider a body placed in an enclosure at a constant temperature slightly lower than that of the body. If the difference of temperature is small enough, we may assume that the rate at which the body loses heat is proportional to this difference. Hence, if S denote the area of the surface of a body, θ the excess of its temperature above that of the enclosure, and E a constant varying with the nature of its surface and the state of the surrounding medium, then the heat lost in a small interval of time, t , is given by

$$h = E S \theta t.$$

Again, if the body be a good conductor of heat, so that its temperature is the same at all points, this loss of heat may be expressed by

$$h = m s \tau,$$

where m denotes the mass of the body, s its specific heat, and τ the small change of temperature accompanying the loss of heat. Thus we have

$$E S \theta t = m s \tau,$$

or

$$\frac{\tau}{t} = \frac{E S}{m s} \theta.$$

That is, *the rate of cooling* $\left(\frac{\tau}{t}\right)$ *is directly proportional to the excess of the temperature of the body over that of the enclosure.* This is Newton's law of cooling.

Exp. 159. Verify Newton's law of cooling. Place some hot water in a copper calorimeter blackened on the outside and arrange matters as in **Exp. 54**. Take readings every 5° C. as the temperature cools from, say, 80° C. to about 35° C. Plot a curve between temperature and time, and show from it that the rate of cooling is very nearly proportional to the difference of temperature between the water in the calorimeter and the surroundings.

Example. In a cooling experiment with a mass of water in a blackened copper calorimeter surrounded by air enclosed in a larger double-walled copper vessel containing water at a temperature of 13.7° C., the times of falling of the temperature of the water in the

calorimeter through successive 5 degrees from 80° C. to 75° C., and so on down to 55° C., were 158, 169, 183, 205, 233 seconds. Use these observations to verify Newton's law of cooling.

Draw up a table thus : -

Excess Temperature of Heat.	Average Excess Temperature, θ , during given Period.	Time to Fall 5° C. ($\tau=5$).	Rate of Cooling, $\frac{\tau}{t}$.	$\theta \div \frac{\tau}{t}$.
° C.	° C.	secs.		
66·3	63·8	158	·0316	2020
61·3		169	·0295	1990
56·3		183	·0273	1970
51·3		205	·0244	2000
46·3		233	·0215	2040
41·3				

The practical constancy of the last column shows Newton's law to be nearly correct. Plot a curve between the average excess temperature, θ , and the rate of cooling, $\frac{\tau}{t}$. This curve will be practically a straight line through the origin (Fig. 159).

In the case taken above the temperature of the body is higher than that of the enclosure. If the temperature is below that of the enclosure a similar formula,

$$\tau = \frac{AS}{ms} \cdot \theta,$$

may be deduced where A is a constant of like nature to E .

In the first case the body *emits* heat, and the constant E is called the **coefficient of emission**. In the second case the body *absorbs* heat, and A is called the **coefficient of absorption**. It will be proved later that for a given temperature of the body and a fixed value of θ the coefficients E and A have the same numerical value.

212. Emission. The coefficient of emission has been defined above. MacFarlane determined this coefficient by application of the relation—

$$\frac{\tau}{t} = \frac{ES}{ms} \theta.$$

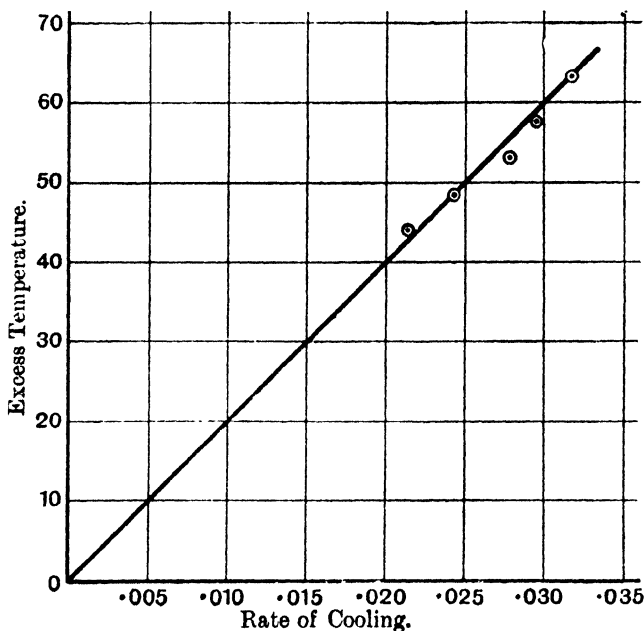

Fig. 159.

A copper ball was allowed to cool in an enclosure maintained at a constant temperature, and the rate of cooling $\left(\frac{\tau}{t}\right)$ was determined. Then, S , m , s , and θ being known, E was readily calculated. It was found that the value obtained was not constant for different values of θ . As θ increased beyond a certain limit, the value of E also increased, thus showing that Newton's law is approximately correct only within certain comparatively small limits. For example, in one

experiment, as θ increased from 5° C. to 60° C., E increased by about 25 per cent.

Example. In the experiment quoted above the mass of water plus the water equivalent of the calorimeter was 63 gm., and the surface area of the calorimeter (which was practically full of water) was about 100 sq. cm. Find an approximate value of the coefficient of emission.

$$E = \frac{ms}{S} \cdot \frac{\tau}{t\theta} = \frac{63 \times 1}{100} \div 2020 = 3 \times 10^{-4} \text{ calorie per sq. cm. per sec.}$$

per deg. C. excess temperature.

213. Comparison of emissive powers. The determination of the *comparative emissive powers* of different surfaces is a simpler matter than determining the coefficient of emission for a given substance. Leslie, and afterwards Melloni, made comparative determinations for a larger number of substances, both using practically the same method.

Leslie employed as source of heat a thin metal cube containing boiling water. The sides of this cube were covered with substances whose emissive powers were to be tested. The radiation from one face of the cube was concentrated by a concave mirror on to one of the bulbs of a differential thermoscope. The indication being noted, the other faces of the cube were tested in the same way, and the relative emissive powers were taken as proportional to the corresponding indications of the thermoscope.

Melloni, adopting the same method, employed the thermopile instead of the differential thermoscope.

Exp. 160. To compare the emissive powers of different surfaces. Take a cubical tin canister, cover one vertical face with lampblack, another with white lead, a third with paper, and polish the fourth. Fill it with water and keep it boiling by a protected flame. Bring the face of the thermopile or the blackened* bulb of an air thermoscope to the same distance (one inch) from each side in turn, and for the same time (three minutes). Note that the index moves farthest when the bulb is opposite the lampblack

* The bulb is blackened in order to increase its absorbing power (Art. 215).

and least when opposite the polished tin. Other surfaces may be compared in the same way.

The arrangement of apparatus adopted by more recent workers is indicated in Fig. 160.

H is a *Leslie's cube*. S_1 is a screen covered with lampblack on the side next H, and polished on the other side. This prevents heat being reflected from the front surface

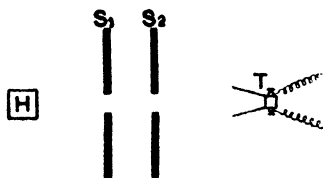

Fig. 160.

back to H, and thence to T, and also diminishes radiation from the other surface towards T. S_2 is another screen to shield T from any radiation from S. It was found that the radiation emitted from polished metallic surfaces was too small to be accurately compared directly with that from a lampblack surface.

To remedy this defect a diaphragm pierced with two holes of different sizes may be employed, so that by using the smaller hole with the lampblack surface, and the larger with the metallic surface, comparable indications can be obtained.

Of course the ratio of the amounts of radiation passing through the holes when used separately with the same source of radiation must first be determined, and then the necessary correction for the difference in sizes of the holes applied to the results of the first experiment.

The following are some of the results:—

EMISSIVE POWERS AT 120° C.

Lampblack	100	Platinum (polished)	...	9.5
White lead	100	Copper foil	...	4.9
Paper	98	Gold leaf	...	4.3
Glass	90	Silver (chemically deposited)	...	5.4
Indian ink	85	„ (ditto, polished)	...	2.2

Exp. 161. Obtain the cooling curves for water in a tin can, whose outside is (i) polished, (ii) jacketed with cotton-wool, (iii) coated with lampblack (hold it in the smoky flame of a lamp, or of burning camphor); (iv) when the blackened can is suspended by cotton loops

within a larger one whose inside is bright, (v) as (iv) but when the inside of the larger can is blackened. Use the same quantity of water in each experiment, begin observations when its temperature is about 80° C., and continue to about 40° C.

Tabulate each case and plot all to a large scale on one sheet of paper. The curves will show roughly the relative emissive powers of the surfaces when (1) polished, (2) lagged, i.e. jacketed with a non-conductor, (3) blackened, (4) when screened by a reflecting surface, (5) when screened by a blackened surface.

214. Stefan's law. It has been shown by experiment that the emissive power varies greatly with the temperature. Several more or less complicated formulae have been deduced from the results of experiment to express the law of cooling in terms of the temperature conditions.

Dulong and Petit laboriously investigated this subject. They found that for a given excess of temperature the rate of cooling depended not only on the temperature of the body, but also on that of the enclosure. The relation established in this connection may be expressed thus. *For a given excess of temperature the rate of cooling increases in geometrical progression as the temperature of the enclosure increases in arithmetical progression.*

More recently, Stefan corrected the results of Dulong and Petit's experiments, and found that they might be expressed by a very different formula. He showed that the emissive power of a body cooling under given conditions is proportional to the fourth power of its absolute temperature, and that this law agrees more closely with the results of experiment than does that deduced by Dulong and Petit.

When a cooling body is surrounded by a gas, its rate of cooling is much more rapid than *in vacuo*, and is found to depend upon the pressure of the gas. In MacFarlane's experiment, referred to in Art. 212, it was calculated that, when the copper ball and enclosure were covered with lamp-black, and cooling took place in air at the normal pressure, one-half of the cooling effect was due to air convection.

215. Absorption. The coefficient of absorption has been defined above in connection with the coefficient of emission. The relation between these two coefficients seems to indicate

that the absorbing power of any surface is proportional to its emissive power for the same kind of radiation. Experiment has shown that this is so.

The absorbing power of any surface is determined by the proportion of the incident radiation which it absorbs. The absolute determination of absorbing power, as thus defined, is somewhat difficult; but in some cases it may be indirectly deduced from the results of other experiments (Art. 201).

The comparison of the absorbing powers of different substances is more easily effected. The arrangement of apparatus employed by Melloni for this purpose is indicated in Fig. 161.

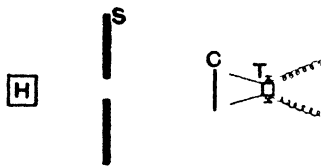

Fig. 161.

H represents the source of heat, SS a perforated screen, T the thermopile, and C a sheet of very thin copper plate coated on the front surface with the substance to be tested, and

on the surface next the pile with lampblack. The first substance tested was lampblack, which, as in the case of emission, was taken as the standard substance. The relative absorbing powers of different substances were then deduced from the data of the experiments in the following way.

Let Q denote the radiation incident on the first surface of C , when covered with the substance to be tested. Then, if a denote the absorbing power of this substance, the heat absorbed is given by Qa . This absorbed heat raises the temperature of the copper until the loss by radiation from its surfaces is equal to the gain of heat. Hence, if t denote the rise of temperature, E the coefficient of emission of the front surface, and E' the coefficient of emission of the surface facing the pile, we have

$$Qa = S(E + E')t, \dots\dots\dots(1)$$

where S denotes the area of the surfaces. Similarly, if both faces of the plate be covered with lampblack, then

$$Qa' = 2SE't', \dots\dots\dots(2)$$

where α' denotes the absorbing power of lampblack. Hence from (1) and (2) we get

$$\frac{\alpha}{\alpha'} = \frac{E + E'}{2E'} \cdot \frac{t}{t'}$$

But the galvanometer deflections, d and d' , are evidently proportional to the heat radiated from the adjacent surface of the plate; hence

$$\frac{d}{d'} = \frac{S E' t}{S E' t'} = \frac{t}{t'}$$

$$\therefore \frac{\alpha}{\alpha'} = \frac{E + E'}{2E'} \cdot \frac{d}{d'}$$

The following results were obtained by Melloni:—

RELATIVE ABSORBING POWERS AT 100° C.

Lampblack	100	Indian ink	85
White lead	100	Shellac	72
Isinglass	91	Metals	13

It will be seen that these results are identical with those given in Art. 213 for relative emissive powers at 100° C.

The same apparatus served to determine the variation of the absorbing power with the nature of the source of heat. In general, the absorbing power is greater the lower the temperature of the source. Hence, when radiation of a complex nature is incident upon any surface, some of the constituents are absorbed, the remainder being reflected or diffused according to the conditions which obtain. This *selective absorption* gives rise to the phenomenon of *thermochrose*, which corresponds to *colour* in the case of light. Every surface has the power of absorbing radiation of a fixed nature made up of constituents of definite refrangibility or wave-length. Hence, when compound radiation containing all or any of these constituents is incident on the surface, these are absorbed, and the character of the unabsorbed radiation is thereby changed, giving rise to *thermochrose* or *colour*, according to the wave-length of the radiation concerned.*

* See also Stewart and Satterly: *Light*, Arts. 113, 118.

It should be noticed that absorption differs from the other phenomena considered in this chapter in that, after absorption, the radiation ceases to exist as radiation, and becomes ordinary heat due to molecular motion. Hence, when a body *absorbs* radiation it rises in temperature, whereas a body which transmits radiation does not rise in temperature.

When an adiathermanous body absorbs heat, it is probable that the absorption takes place at the surface or in a very thin superficial layer; but in a diathermanous body absorption takes place during transmission (Art. 209), and, it may be, at the surface also. Lampblack is the only one of the substances which have been tested which does not exhibit selective absorption. It absorbs all kinds of radiation to the same degree.

Exp. 162.* Show that a black surface absorbs rays of radiant heat to a greater extent than a polished surface. Pin a sheet of heat-sensitive paper (Art. 194) to a wooden frame F (Fig. 162). Fix to the plain side of the sheet a large tinfoil star and in the centre of this star paint another star in dead-black.†

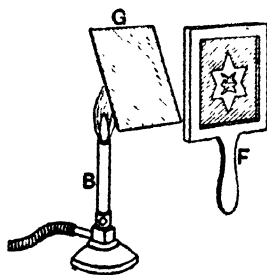

Fig. 162.

Fix up a piece of wire gauze over a Bunsen burner as shown in Fig. 162 so that it serves as a source of radiant heat, and hold the screen about 10 cm. from the gauze, the star towards the gauze. Observe the sensitive side of the screen. First there appears a green star of the form of the dead-black star and then a green background outside the large star. The paper behind the untreated part of the tinfoil remains white. This shows that polished metal absorbs little or no heat, but that when

the polish is destroyed by a black paint heat is absorbed.

A variant of this experiment is to use a piece of tinfoil fixed in a screen. The back of the tinfoil is coated with a mixture of red mercuric oxide and gum. The oxide turns yellow at 150°C . A design is painted in black on the tinfoil. When a hot iron is held about 5 cm. in front of the tinfoil the mercuric oxide behind the design turns yellow, the rest remains unaltered red.

* The apparatus used in this experiment may be obtained ready made from W. B. Nicolson of Glasgow.

† See footnote, p. 160.

216. Theoretical relations between reflection, diffusion, absorption, and emission. Let Q denote the quantity of radiation incident on the surface of a body. This, in the most general case, may be divided into two parts: Q' , which is arrested at the surface, and q , which is transmitted by the substance of the body. That is, $Q = Q' + q$. Now, considering Q' , we have, as in Art. 210,

$$Q' = Q (r + d + a).$$

The quantity q is diminished by continuous absorption during transmission; and, if a denote the coefficient of transmission (Art. 210), then $q a^n$ gives the intensity of the transmitted radiation after passing through a thickness n cm. of the substance.

We shall now consider some particular cases of this general case. In each case the substance is supposed to be adiathermanous, so that q is zero, and therefore $Q' = Q$.

1. Let the surface be polished. If the polish is sufficiently perfect, $d = 0$. Hence, we have

$$Q = Q (r + a).$$

$$\therefore 1 = r + a,$$

or—

$$a = 1 - r.$$

That is, the absorbing power of the surface is complementary to its reflecting power. Hence, when a reflecting surface of this nature reflects well it absorbs badly—that is, when r is large a is small.

2. Let the surface be rough. The surface being unpolished, $r = 0$. Therefore

$$Q = Q (d + a).$$

$$\therefore a = 1 - d.$$

That is, the absorbing power is complementary to the diffusive power. Hence, when a surface diffuses well it absorbs badly.

From these two cases it is evident that, under the conditions considered, a can be calculated when r or d is known.

3. Let the surface be imperfectly polished. Then we have

$$Q = Q(r + d + a).$$

$$\therefore a = 1 - r - d = 1 - (r + d).$$

That is, the absorbing power is complementary to the sum of the reflecting and diffusive powers. By polishing the surface, r is increased and d decreased, so that the sum $(r + d)$ may remain constant, increase, or diminish. That is, the absorbing power of a surface may remain constant for different conditions of polish, or may increase or diminish with the degree of polish.

Since the values of r and d vary with the angle of incidence of the radiation, it follows that the absorbing power, a , also varies with the angle of incidence in such a way as to be always complementary to r , d , or $(r + d)$.

If the diathermancy of a plate of rock-salt be tested for radiation from a hot piece of the same substance, it will be found to be very small; a thin plate absorbs more than 75 per cent. of the radiation; and, if the plate be at the same temperature as the radiating piece, it will be found that none of the incident radiation is transmitted by it. Hence the radiation absorbed by any substance at a given temperature is of the same nature as that emitted by the substance at the same temperature.* From this it follows that the absorbing power of any substance is proportional to its emissive or radiating power at the same temperature.

The colour of a body has also some influence on its absorbing power: e.g. a white coat absorbs less heat in the sunshine than a black one.

Exp. 163. Take two equal polished tins (e.g. cigarette tins, coffee tins, etc.); blacken the surface of one by means of a lamp flame. Fill both with water, and set them in front of a bright fire. After half an hour test the temperature of the water with a thermometer. The water in the blackened tin will be the hotter.

* Compare this with the production of the Fraunhofer lines in the solar spectrum. (See Stewart and Satterly: *Light*, Art. 111.)

217. Prevost's Theory of Exchanges. *This theory asserts that every body emits radiation in all directions to an extent determined only by its temperature and the nature of its surface, and that it absorbs radiation from all sources to which it is exposed.*

Suppose that in Exp. 155 on reflection a piece of ice takes the place of the hot iron ball at F (Fig. 156). It will be found that the thermometer at F' indicates a fall of temperature. This result is very neatly explained by the above theory. The ice at F radiates in all directions at a rate dependent on its temperature. A portion of this radiation is reflected by the mirror M on to M', and thence to the bulb of the thermometer at F'. Similarly, the thermometer radiates in all directions at a rate dependent on its temperature, and a portion of this radiation is, after reflection by M' and M, concentrated on the ice at F. Hence, considering the thermometer, it gains heat by radiation from the ice, and it loses heat by its own radiation; and in this case, since the temperature of the thermometer is higher than that of the ice, the loss is greater than the gain, and the temperature falls. In Exp. 155 with the hot iron the gain is greater than the loss, and the temperature of the thermometer rises.

When bodies are at the same temperature, each loses as much by its own radiation as it gains by radiation from surrounding bodies, and thus the temperature of each remains constant. Consider an enclosure maintained at a constant temperature, and having a thermometer suspended in its interior. Whatever may have been the initial temperature of the thermometer, it ultimately takes and retains the constant temperature of the enclosure. When this is the case the heat which the thermometer gains by radiation from the walls of the enclosure equals the heat which it loses by its own radiation. That is, the radiation absorbed by any body at a given temperature is equal and identical with the radiation emitted by the same body at the same temperature. This result we have already deduced from experiment, and it therefore affords an indirect experimental proof of the theory of exchanges.

Again, if a large number of thermometers, whose surfaces are covered with different substances, are suspended in the enclosure, they all ultimately take up a common constant temperature equal to that of the enclosure.

Now, considering any one of these thermometers, we have evidently a more complex system to deal with than in the case just considered. The thermometer receives radiation from the walls of the enclosure, and also from each of the thermometers. The radiation from the walls is of a definite kind, determined by the nature of the surface. Also the radiation from each of the thermometers is of a definite kind, similarly determined; but the nature of the surface being different in each case the radiation emitted is also different. Hence, the thermometer considered receives a large number of different kinds of radiation, and emits one kind of radiation determined by the nature of its own surface. But since the temperature remains constant it follows that heat gained must equal the heat lost—that is, the radiation emitted must be identical in quantity and *quality* with that absorbed.

This statement seems to imply that the radiation of any body is determined by the radiation it absorbs, and not by any inherent property. This is, of course, not the case; the radiation emitted by any body cannot be controlled by any merely external circumstances. If the thermometer emits radiation other than that which it absorbs—that is, *other than that which is emitted by the bodies from which it receives radiation*—then this radiation, since it is not emitted by the other bodies, cannot be absorbed by them, and is therefore returned to the thermometer by reflection or diffusion, and is there absorbed. Thus, it is evident that in an enclosure of this nature the stream of radiant heat is constant in quantity and quality, for each surface restores by its own radiation a quantity exactly equal and similar to that which it absorbs.

For example, imagine four of the thermometers to have respectively surfaces of lampblack, gold-leaf, glass, and powdered silver. The lampblack surface absorbs nearly all the incident radiation, and emits a corresponding quantity.

The gold-leaf surface reflects a large percentage and absorbs the remainder; hence, it emits but a small amount. The glass surface reflects and transmits a proportion depending on the nature of the radiation, and absorbs the rest, which corresponds to the radiation which it emits. The powdered silver surface diffuses a large amount, and therefore absorbs and emits but little.

From what has been said above it will be seen that for any two bodies, A and B, exposed to each other's radiation at the same temperature, there is a *constant, interchangeable* quantity of radiation, capable of absorption by each. Thus, of the radiation emitted by A, a portion, q , of fixed quantity and quality, is absorbed by B; this is again emitted by B, forming a portion of the entire radiation emitted by that body.

When this radiation from B falls upon A, the quantity q only is absorbed, for every constituent capable of emission by B and absorption by A is also capable of emission by A and absorption by B, and is therefore included in the quantity q . Hence if we denote the radiation emitted by A by $m q$, and that emitted by B by $n q$, we have

$$\frac{\text{Radiating power of A}}{\text{Radiating power of B}} = \frac{m}{n}.$$

Also—

$$\frac{\text{Absorbing power of A for radiation emitted by B}}{\text{Absorbing power of B for radiation emitted by A}} = \frac{q/nq}{q/mq} = \frac{m}{n}.$$

That is, the absorbing power of any substance, A, for radiation emitted by any other substance, B, at the same temperature, is to the absorbing power of B for radiation from A as the radiating power of A is to that of B.

For example, consider the case of a thermometer suspended in an enclosure at constant temperature. Suppose the radiating power of the walls of the enclosure to be five times that of the thermometer, and that the walls absorb one-fourth of the radiation from the thermometer; then, in order that the temperature of the thermometer may remain constant, it must absorb a quantity of heat equal to one-fourth of its own radiation—that is, to one-twentieth of the radiation from the walls of the enclosure which,

by hypothesis, is five times that from the thermometer. Hence, the radiating and absorbing powers of the thermometer and the walls of the enclosure have the common ratio 1 : 5. This relation is true for each constituent of the radiation to which it applies.

218. Radiation of gases. Gases in general radiate badly, but in most cases the phenomena of selective absorption and radiation are very strongly marked.

The radiation from a solid, at a given temperature, is generally included within a certain range of wave-length. As the temperature increases this range is extended in the direction of increasing refrangibility, while each constituent increases in intensity.

Gases, on the other hand, emit radiation made up of one or more constituents of definite wave-length; as the temperature increases other constituents of shorter wave-length may be added, and the intensity of each of the original constituents is increased.

In the construction of furnaces the hot gases are made to play on some substances such as fire-bricks, which are good radiators. These become heated by direct contact with the hot gases and then radiate the heat freely in all directions. Asbestos balls used in gas-fires and fire-clay bricks used as backs to ordinary grates further illustrate this principle.

The rare oxides thoria and ceria when hot emit light very readily; hence their use in the Welsbach mantle.

219. Illustrative experiments and phenomena. We shall here consider some natural phenomena and a few more simple experiments which illustrate the principles and laws deduced in this chapter.

The effect of the nature of the surface of a body may be seen by noting the rate of cooling of water in a vessel whose surface can be varied. If the vessel has a brightly polished metallic surface the water cools very slowly, but if covered with lampblack the rate of cooling is very much faster (Art. 213). For this reason teapots and vessels intended to keep their contents warm should have

brightly polished surfaces. Similarly, if a vessel having a brightly polished surface is exposed to radiation it absorbs heat very slowly, whereas if the surface is rough and blackened the incident radiation is more rapidly absorbed. The exterior of a calorimeter is kept bright so that it may neither radiate nor absorb heat. Hot water pipes are blackened to increase the radiation from them. These experiments show that a good reflecting surface radiates badly and also absorbs badly. Lampblack is the best radiator and absorber of heat known, but it is the worst reflector.

These results may be exhibited with the apparatus shown in Fig. 163. A is a sheet of thin copper with a brightly polished surface facing B, another similar sheet, having a lampblackened surface turned towards A. A and B are connected by a copper wire, *w*. Two iron wires *i* and *i'* are joined, as shown in the figure, to the backs of A and B, and to the galvanometer G. A copper-iron circuit* is thus formed, having the junctions at A and B. A heated ball of metal is now supported midway between A and B, so that the copper plates are equally exposed to its radiation. Before long the galvanometer shows a gradually increasing deflection, indicating that the junction at B is heating more rapidly than that at A.

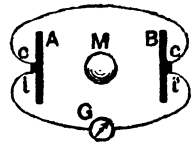

Fig. 163.

The following is another experiment due to Tyndall illustrating the same point.

Exp. 164. Write a word with ordinary ink on a piece of bright thin platinum foil and then heat the foil to a bright white heat. It will be seen that the written characters which have a rough surface of iron oxide glow much more brightly than the rest of the foil. If the reverse side, on which there is no writing, is observed it will be seen that the writing is visible on it as a dark pattern on a bright ground. The letters, on account of the nature

* See Art. 252 for the principles of the thermo-electric circuit.

of their surface, radiate more than the foil, and therefore cool more rapidly. Hence the foil immediately underlying the writing also cools by conduction more rapidly than the rest of the foil, and thus appears dark in comparison with the other portions of the same surface.

Exp. 165. Obtain a piece of white earthenware bearing a dark coloured design. When cold the design absorbs most of the light falling on it, the rest of the earthenware

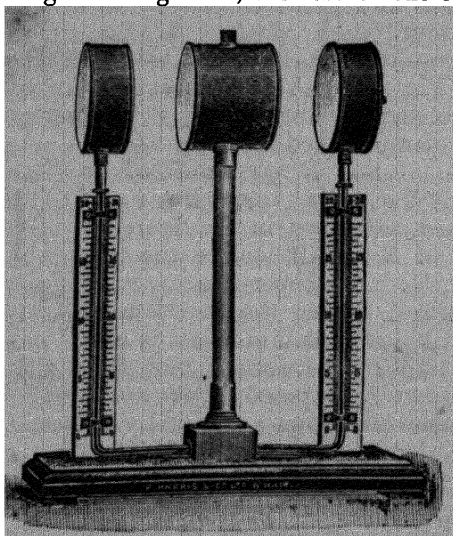

Fig. 164.

appears white by diffusion. Now heat the earthenware in a fire or gas furnace. When quite hot withdraw it and place it in the dark. Observe now that the design gives off more light than the other portion of the earthenware.

Ritchie devised a very convenient form of apparatus to show the equality of the radiating and absorbing powers of a surface. It is shown in Fig. 164, and comprises two cylindrical reservoirs full of air joined together by a glass tube bent twice at right angles and carried on a stand at

the back of the two upright glass tubes. This portion constitutes a Leslie's differential thermoscope.

Between the two reservoirs is a third and larger one which can be filled with hot water. It is movable along a horizontal support. Each small reservoir has one face coated with lampblack, the other being left bright. The black end of one and the bright face of the other face inward. The centre reservoir has similarly one face black and the other polished, and it is placed so that its bright end faces a black end of one small reservoir and its black end the bright end of the other small reservoir.

When the centre reservoir is filled with hot water its bright face radiates to a black face, and its black face to a bright face. It is found by experiment that when the centre reservoir is midway between the other two the liquid in the stem of the thermoscope does not move, indicating that the air in the two reservoirs is at the same temperature.

The various phenomena of diathermancy are capable of simple illustration. If radiation is transmitted through a plate of ice, the interior of the plate begins to melt, showing beautiful hexagonal ice crystals; but the radiation, after passing through this plate, may be passed through another plate or lens of ice without causing the least melting. This shows that the absorption which radiation undergoes during transmission through any substance is such as to fit it for further transmission without absorption.

The glass fire-screens occasionally used are applications of the fact that the diathermancy of glass varies with the nature of the radiation. The radiation from the fire falling on the screen is partly absorbed and partly transmitted; the more refrangible luminous portion is transmitted, while the less refrangible portion, of greater heating power, is absorbed and afterwards radiated by the screen. In this way the cheerful firelight is transmitted, but the more intense heat rays are absorbed, and afterwards emitted by the screen as radiation of a less intense nature.

Glass is employed in hot-houses for the following reason. Of the solar radiation incident on the glass only the more refrangible luminous portion is transmitted. This portion,

however, forms a large percentage of solar radiation, and has considerable heating effect; hence, when absorbed by the objects within the hot-house, it gradually raises their temperature. The radiation from these objects, being of low refrangibility, is not transmitted by the glass, and cannot in this way escape to the exterior. This radiation is, however, absorbed by the glass; but, owing to absorption of a portion of the solar radiation, the glass is at a higher temperature than the objects inside the house, and therefore returns to them by its own radiation more than it receives. In this way the temperature of the interior gradually rises, and will continue to do so until it attains the temperature of the glass.*

The water vapour in the atmosphere acts in much the same way towards the earth as the glass does towards the objects inside a glass house. Dry air is very diathermanous to radiant heat, but the absorptive power of air charged with water vapour is from 30 to 70 times as great as that of dry air (see Art. 209), while it is still very transparent to rays of light. Thus the earth is protected by the absorptive action of the water vapour from the more intense heat rays of the sun; but when the warmed earth begins to radiate its heat in rays of low refrangibility these rays find a most effectual barrier to their escape in the water vapour, which absorbs them freely and becomes warmed thereby.

In this way extremes of temperature are avoided—the direct heating effect of the sun during the day and the loss of heat by radiation during the night are both diminished.

In districts where little water vapour is present in the air—for example, in the Desert of Sahara—the days are intensely hot and the nights extremely cold. Probably other causes have something to do with these and similar results, but the action of water vapour has undoubtedly an important bearing on the question.

* The above explanation has recently been controverted by R. W. Wood, who says that the only action of the glass is to keep the same air within the house all the time, and the temperature of this air will, of course, naturally rise as time goes on.

In summer the plains and valleys especially are covered by a protecting stratum of vapour which serves to prevent the escape of radiant heat, and when night falls they remain comparatively warm. But sandy deserts, mountain tops, and elevated table-lands, above which there is much less vapour, cool down quickly.

EXERCISES XIV.

1. A clear piece of rock-salt, a bright piece of tin-plate, and a piece of black wood are exposed to the radiation of a common fire. State what happens in each case, and what is the final state of each as regards temperature.

2. Define the coefficient of transmission of a substance for radiation. If the coefficient of absorption of a substance for a particular variety of radiation is $\cdot 0012$, what percentage of the incident radiation will get through a plate of the substance 3 mm. thick.

3. If a plate of glass allowed 40% of the light incident upon it to pass through, how much light would be transmitted by a plate of the same glass of four times the thickness, assuming that no light is lost by reflection at the surfaces in either case?

4. Letters are written in ink upon a bright piece of platinum-foil which is subsequently placed in the flame of a Bunsen burner in a dark room. Looked at on one side bright letters appear on a dark ground; on the other side, dark letters on a bright ground. Explain this.

5. If the bulb of a blackened thermometer be enclosed in an outer case of glass, a vacuum being between the two, it is seen that when exposed to the sun's rays its temperature becomes high. Explain this, and mention any transparent substance which would not have the same property in this respect as glass.

6. What special properties in relation to radiation are shown by lampblack, brightly polished silver, glass, quartz, rock-salt, alum, solution of iodine in carbon bisulphide?

7. A current of steam at atmospheric pressure is passed through an iron tube 2 metres long, inside radius 2.4 cm., outside radius 4 cm. The thermal conductivity of iron being 0.15, the coefficient of emission for the surface of the tube is 0.0003, the latent heat of steam 540, and the temperature of the surrounding chamber $0^{\circ}\text{C}.$; find the quantity of steam condensed per hour by the cooling effect of the air.

EXAMINATION QUESTIONS ON CONDUCTION AND RADIATION.

1. Define the conductivity of a substance for heat. How would you propose to find whether a liquid can conduct heat or not?

2. Define the *thermal conductivity* of a substance.

If the inside surface of a glass window 5 millimetres thick is at a temperature of 15°C ., and the outside surface is at a temperature of 0°C ., how much heat escapes through a square centimetre of the window in a minute? (Conductivity of glass = $\cdot 001$ C.G.S. unit.)

3. It is found that the temperature of the rocks below the earth's surface increases at the rate of (approximately) one degree C. for each 30 metres of descent. Taking the thermal conductivity of the rocks as $\cdot 005$ in the C.G.S. system, calculate how much water would be raised from the freezing point to the boiling point by the heat arriving in the course of a year at a square metre of the earth's surface from its interior.

4. How is the property whereby a solid conducts heat measured? Suppose 10 cm. of ice to have already formed on a pond, and that the air is at -5°C ., how long approximately will it take for the next mm. to form? (Conductivity of ice = $\cdot 0052$ absolute unit.)

5. A metal vessel, 1 square metre in area, and whose sides are $\cdot 5$ cm. thick, is filled with melting ice, and is kept surrounded by water at 100°C . How much ice will be melted in an hour? The conductivity of the metal is $\cdot 02$ C.G.S. unit.

6. Explain how the conductivity of a good conductor like copper may be measured.

7. In what respects does radiant heat differ from light?

Why are rock-salt lenses employed for experiments with radiant heat coming from a source at a low temperature, while glass lenses suffice when the sun or the electric lamp is the source of heat?

8. Describe the construction and action of a thermopile and explain how it can be used to find the quantities of heat emitted by two hot bodies.

9. By what experiments would you show that the radiation from an arc lamp extends beyond the red at the one end, and beyond the violet at the other end of the spectrum? In what respects do these invisible radiations differ from the visible radiations?

10. Two air-thermoscopes, one with a clear glass bulb, the other with a bulb covered with gold-leaf, are placed (a) one after another at the principal focus of a convex lens presented to the sun, (b) at equal distances in front of a common fire.

Further illustrations. (i) A pile-driver before being allowed to fall has potential energy, which has been stored up in it by the men who pulled it up into position, and this energy is converted into kinetic energy when the pile-driver is released.

(ii) A lake up in the hills has potential energy. No work can be done by it, however, unless the water is allowed to run down, and thus acquire kinetic energy.

(iii) When a watch-spring is wound up work is done upon it against the elasticity of the spring. When permitted to do so the spring will emit this work again in turning the wheels of the watch as it tends to unwind itself. This also is a case of potential energy. In this case, however, energy is imparted to the body (*i.e.* the spring), not by raising it, but by distorting it.

(iv) Suppose two particles tied to a piece of elastic string and placed on a table so that the string is taut but not stretched. If the string be stretched and then set free, the particles move towards each other, *i.e.* the string employs force on the particles. Thus, in the stretched position, there was stored up in the string potential energy which was changed to kinetic energy of the particles when the string was released.

We see then that a body may possess potential energy (1) when it is raised without distortion above the level of the earth, (2) when its shape is distorted.

235. Work in any portion of an electric circuit. Consider any portion of an electric circuit, *e.g.* A B, Fig. 168, suppose a current of C amperes flowing in it, and let V volts be the potential difference between its extremities A and B. Then in one second C coulombs enter this portion of the circuit at A and leave it at B, so that they fall through V volts.

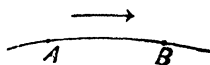

Fig. 168.

The fall of electricity through a potential difference is analogous to the fall of water or other material substance from a height, and in both cases work is done. The work done by an electrostatic unit quantity of electricity falling down a unit electrostatic potential difference is one erg. It is shown in more advanced text-books* that one coulomb, the practical unit of quantity of electricity, is equal to 3×10^9 or 3,000,000,000 electrostatic units of quantity. Also that a potential difference of one volt is equal to $\frac{1}{300}$

* See Stewart: *Higher Text-book of Magnetism and Electricity*, Art. 199.

of an electrostatic unit of potential. From which it follows that the work when one coulomb drops a potential difference of one volt is equal to $\frac{3 \times 10^9}{300}$ or 10^7 ergs. Now a joule is equal to 10^7 ergs, hence the work done when one coulomb of electricity falls down a potential of one volt is equal to one joule. Hence if C coulombs of electricity pass through a portion of a circuit and the potential drop is V volts the electrical energy spent is $C V$ joules, or, in other words, if C is the current, the rate of work is $C V$ joules per second or $C V$ watts.*

We may therefore state our result thus :—

When a current of C amperes flows through a portion of a circuit the P. D. of whose extremities is V volts, it delivers energy to that portion at the rate of $V C$ watts. For shortness this may be written :—

$$\text{Rate of work} = V C \text{ watts} \dots\dots\dots (1)$$

or still more simply :—

$$\text{Watts} = \text{volts} \times \text{amperes} \dots\dots\dots (2)$$

the latter being the form usually quoted by electrical engineers, to whom the relation is of frequent service.

The English unit of power, the horse-power, being equal to 746 watts, we have, corresponding to equation (2),

$$\text{Horse-power} = \frac{\text{volts} \times \text{amperes}}{746} \dots\dots\dots (3)$$

236. Energy can be transferred from one body to another. If a billiard ball in motion strikes one at rest, the latter begins to move whilst the former either slips or moves on with speed diminished. Thus the ball which had no energy before the impact possesses energy after the impact, whilst the ball originally in motion loses part of its energy. It follows that energy has been transferred from one ball to the other.

Impact is one method of transferring energy. Probably

* If $A B$ is an inert wire, the whole of this work is converted into heat and raises the temperature of $A B$. If $A B$ contain apparatus, e.g. motors or dynamos, which use or supply energy, the above work is the algebraic sum of that converted into heat and that utilised by the apparatus.

a more common way of bringing about such a transfer is illustrated as follows. Hold in the hand one end of a strong string to which a weight is attached. Move the hand to and fro in a horizontal line. No particle of the string moves, except to vibrate in a horizontal line, but the movement passes along the string in the form of **waves**, until the particles near the weight and finally the weight itself are set in motion. Thus, without the transfer of any *material* from the hand to the weight, motion, and therefore kinetic energy, has been transferred by vibrating an intermediate medium. If a bundle of strings was tied to the weight and held by the hand, and if the hand were made to vibrate in the same way, exactly the same phenomenon would be witnessed.

Thus, whether the intervening medium be as fine as a fine string or have a considerable section like the bundle of strings, energy may be transferred from one body to another without the transfer of matter. It is probably by means of the vibrations of some such intervening medium called the *ether* that the energy of the sun is transferred to us and makes itself sensible as heat and light (Art. 200).

237. Several forms of energy. There is reason to believe that the particles of every body, whether solid, liquid, or gas, are in perpetual vibration. Indeed the heat which bodies possess and emit is most probably due to the vibration of their particles. Owing to their vibration these particles possess kinetic energy, and it is assumed that what is called heat is due to this energy (Art. 4).

It is now firmly held that not only heat but also light and sound are only forms of energy. Great experimenters have shown (1) that any one form of energy can be converted into any other, (2) that in such a conversion the quantity used up of the one is invariably equal to the quantity of the other created. It is not difficult to show the transformation from one form to another by simple experiment, but to show the strict equality between the quantities used and created requires special apparatus. The subjects of the transformation of work into heat and *vice versa* will be treated in detail in the next chapter.

Exp. 167. On the transformation of electric energy into mechanical energy. Suspend a pith ball by a dry silk thread between the charged knob of an electrical machine and a conductor connected to earth by a copper wire.

Notice that

- (i) the ball is attracted to the charged plate ;
- (ii) it is then repelled until it touches the conductor ;
- (iii) these motions are repeated a very considerable number of times.

When the pith ball is first suspended it has no kinetic energy. Immediately it is set free it moves, *i. e.* it takes up kinetic energy. What is the source of this energy? It cannot be the conductor, for that differs in no way physically from the suspended ball. The source, therefore, must be the electricity of the charged plate. This is confirmed by the facts that (i) the first motion of the suspended ball is towards the plate, (ii) the motion ceases when the plate originally charged ceases to give any sign of electrification when tested by the usual means.

Deduction.—We conclude, therefore, that the electrical energy with which the plate was originally endowed has, to some extent at least, been transformed into the kinetic energy of the particle.

Note.—Only a very small portion of the electrical energy, however, has been thus transformed.

Exp. 168. On the transformation of electrical energy into heat. Partly fill a fair-sized beaker with water. Solder a coiled piece of thin platinum wire to two thick copper leads coming from a battery of several cells through a key. Place the platinum coil in the beaker; place also therein a thermometer. Now press the key to let the current pass, and keep it down for some minutes.

Notice the rise of temperature indicated by the thermometer.

Deduction.—We have here, therefore, *heat energy* which did not previously exist; and the only possible source of it is the electrical current passing through the wire. This *electrical energy* is derived from the *chemical energy* of the constituents of the cell.

While the current is passing it will be found that a considerable quantity of heat is produced in the cells of the battery; this heat is partly due to the passage of the electric current through the cell, but is mainly due to chemical actions which are going on.

EXERCISES XV.

1. Define work. Give an illustration to show how a moving body may do work.

2. How much work is done in each of the following cases? Give the answers in appropriate units.

(a) When the mass of 10 lb. falls 6 ft.

(b) By a man of 10 stone weight walking upstairs to a height of 50 ft.

(c) By a force of 4 poundals acting through a distance of 10 yards.

(d) By a machine pulling a million grammes of coal up a pit a thousand metres deep.

(e) By a force of 3 dynes acting through 2 centimetres.

3. When is the energy of a pendulum bob (i) wholly potential, (ii) wholly kinetic?

4. When an arrow is on the point of release the bow possesses potential energy. What is the difference between this case of potential energy and that of a body raised above the level of the earth?

5. A bullet leaves a gun with a velocity of 800 feet per second. The length of the barrel is 30 inches and the mass of the bullet is 1 oz. Find (1) the kinetic energy of the bullet when it leaves the muzzle; (2) the average force on the bullet while in the barrel due to the powder, assuming that the force is uniform.

Express the force in poundals, pound-wt., and in dynes.

6. A bullet of mass 25 gm., moving with a velocity of 300 metres per sec., is stopped by impact against a bone, being brought to rest within a distance of 3 cm. from first striking. Calculate the average force exerted by the bullet on the bone.

7. Define the terms work, force, pressure. Show that if a piston is moved along a cylinder against a constant pressure the work done in a stroke is equal to the product of the pressure into the volume swept out by the piston. Explain clearly the units in which the work will be given by the calculation.

8. What is meant by Energy of Position? A reservoir of water of area 330,000 square feet is initially of uniform depth, 10 ft. How many foot-pounds of work can it supply to a turbine on a level with the bottom of the reservoir, and what horse-power can it maintain on an average if it is emptied in 10 hours?

9. In a certain storm the height of the barometer fell from 771 mm. to 735 mm. Find the change of pressure on the earth's surface in C.G.S. gravitational units.

10. Electrical energy is supplied at a pressure of 200 volts to a hall for lighting purposes. The average current taken is 5 amperes and the lights are used for 96 hours. Calculate the electricity bill given that the price of electrical energy is 4d. per kilowatt hour.

CHAPTER XVI.

THE MECHANICAL EQUIVALENT OF HEAT.

238. Introductory. It has already been stated that heat is a form of energy, and that a given quantity of heat, measured in any arbitrary units, has a definite and constant equivalent in mechanical work or energy measured in mechanical units such as foot-pounds or ergs. We shall now briefly sketch the experiments and arguments which establish the truth of this dynamical theory of heat.

Up to the commencement of the last century heat was considered to be a material "igneous fluid" called *caloric*, which, according as it was present in a substance in large or small quantities, rendered that substance hot or cold. When it was shown that heat could be produced by friction, percussion, and other mechanical means, this was explained by assuming that these mechanical actions changed the condition of some portion of the body, and thus diminished its capacity for heat; or, in plainer terms, some of the caloric was forced out of the body and made to appear as sensible heat.

The dynamical theory of heat was established by two distinct steps. Towards the close of the eighteenth century the experiments of Rumford and Davy showed that *heat could not be a material substance*, and thus the old caloric theory of heat was disproved. This theory, however, still held the field until, in 1849, the results of Joule's quantitative experiments established *the equivalence of heat and work, and proved that heat must be a form of energy*. Later experiments by other experimenters and the mathematical

development of the subject by Rankine, Thomson (Kelvin), and Clausius entirely confirm this result, and completely establish the dynamical theory.

239. Rumford's experiments. Count Rumford was an Anglo-American in the employ of the Bavarian Government, and was led to experiment on this subject whilst superintending the boring of cannon at the Munich Arsenal. He noticed that during boring a large amount of heat was developed both in the cannon and in the boring-bar, and, struck with the apparently unlimited supply of heat, he determined to try and find out whether heat was really a material fluid (*caloric*), as it was then considered to be.

In considering the method of his experiment, it occurred to Rumford that if the heat was forced out of any part of the system he had to deal with, it came most probably from the borings, and accordingly he decided to determine whether there was any difference between the specific heats of the borings and the solid metal. This he did by taking equal weights of each, heating them to 212° F., and then immersing them separately in equal quantities of water at the same temperature. After one minute the rise of temperature in each case was the same. This experiment he repeated several times with the same result, and finally came to the conclusion that the heat produced could not have been furnished at the expense of the borings.

Still pursuing the same train of thought, Rumford determined to use a *blunt* borer, so that only a very small quantity of borings should be produced in a given time. He arranged apparatus for this experiment, and found that an enormous quantity of heat was still evolved, although the weight of the borings produced was only about one-thousandth of that of the whole apparatus.

Rumford was now convinced that the heat could not come from the borings; neither could it come from any other part of the apparatus, for the metal was still in its initial condition and must therefore have the same specific heat, and every part of the system was *gaining* heat instead of losing it.

It then occurred to him that the only other source from which the heat could come was from the air. He accordingly excluded the air by causing the boring to take place under water. In two and a half hours from the commencement of the experiment the water boiled. This heat, it was argued, could not have come from the water, for the only change of condition experienced by the water was that due to *gain* of heat. From these experiments Rumford came to the conclusion that heat was *not* a material substance. In a paper published in 1798 he states his case thus: "Anything which any insulated body, or system of bodies, can continue to furnish *without limitation* cannot possibly be a *material substance*; and it appears to me to be extremely difficult, if not quite impossible, to form any distinct idea of anything capable of being excited and communicated in these experiments except it be *motion*."

240. Davy's experiments In 1798 Sir Humphry Davy showed that when two pieces of ice are rubbed together in a vacuum the ice melts, even if the initial temperature of the ice and its surroundings be some degrees below the freezing point. The melting of the ice shows that heat is produced, and its production cannot be due to a diminution of thermal capacity, for the specific heat of the water produced is *greater* than that of the ice. Davy did not at the time see the full significance of this result, and it was not until 1812 that he clearly stated his opinion that heat was a form of molecular energy.

Exp. 169. Hammer a piece of lead, saw wood, etc., and test the temperature of the lead, saw, etc., before and after the experiment. It will be found that the temperature has risen.

Exp. 170. Rub a brass nail or button on a wooden seat, and notice its increase in temperature.

Exp. 171. Bore a hole in a piece of hard wood with a brad-awl. The brad-awl becomes hot.

Exp. 172. Feel the axle of a wheel which has been rotating rapidly. It is warm, possibly hot.

Exp. 173. Take a piece of thin iron plate and bend it forwards and backwards to produce fracture along a certain line. Feel the metal at this line. It is hot.

Exp. 174. Use a bicycle pump to inflate the tire or pump air into a closed bottle. Note that the pump becomes warm. Part of this is due to friction between the piston and the barrel; but the greater part is due to the heat developed in the air on compression.*

Deduction.—In these experiments the mechanical work expended in impact, friction, etc., has been transformed into heat.

Exp. 175. Blow air by a pair of bellows against the face of a thermopile. The indication of the galvanometer shows that the temperature of the air has risen by reason of the work done upon it.

Exp. 176. Allow compressed air to expand from a cylinder of compressed gas. Cooling occurs.

Study a steam engine. Note the transformation of the energy of the heat of the burning coals into the energy of mechanical motion.

241. Joule's experiments. Notwithstanding the conclusiveness of Rumford's and Davy's experiments, they excited but little interest at the time, and the material or caloric theory continued to be held by most physicists up to the year 1840. It was not, however, till 1849 that the dynamical theory was generally accepted. In this year Dr. Joule, of Manchester, completed a series of experiments, which not only showed that heat was a form of energy, but accurately determined the quantitative relation between a given quantity of mechanical energy and the equivalent quantity of heat.

* To test this point work the pump with the nozzle open; the pump becomes only slightly warm.

Joule's most important experiments were on the development of heat by fluid friction and on the heat effects associated with the compression and expansion of gases. Some of these experiments are described in the following Articles.

242. Joule's earlier experiments on fluid friction. The most important of Joule's experiments consisted in the development of heat by churning water in a copper vessel by means of a suitable paddle. The friction of the water

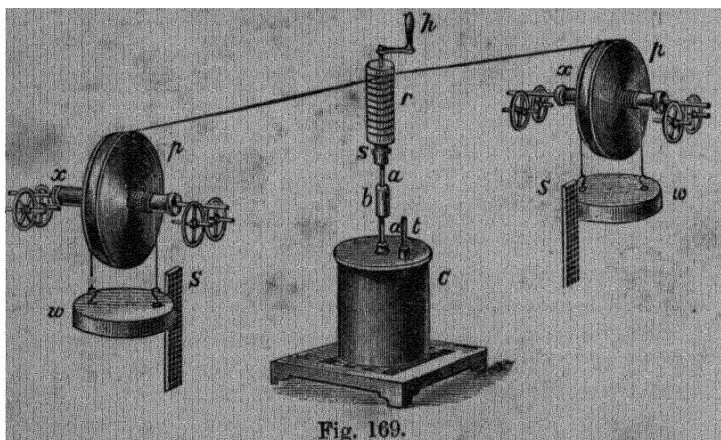

Fig. 169.

on itself and on the surfaces of the vessel and paddle produced heat, which resulted in an appreciable rise in the temperature of the water.

The apparatus used in this experiment is shown in Fig. 169. C represents the vessel containing the water. It was made of copper 10 in. high and 7 in. diameter, and was capable of containing about 10 pounds of water. Inside it were fixed vertically four vanes or partitions, arranged as shown in the sections given in Fig. 170. The vanes were attached to the brass framework which supported the sockets for the axle of the paddle, in such a way as to leave a free central space in which this axle

revolved. The paddle consisted of a central axle carrying eight sets of brass vanes fixed at equal angles as shown in Fig. 170. The axle, *a a*, revolved in two sockets at the top and bottom of the vessel *C*, and the revolving vanes, *v*, passed through spaces cut in the stationary partitions, *p*, just as a key turns in the wards of a lock. By this arrangement the water was prevented from rotating in the direction of revolution of the paddle.

The motion of the paddle was produced by the fall of two equal leaden "weights," *w w*, each either 10 lb. or

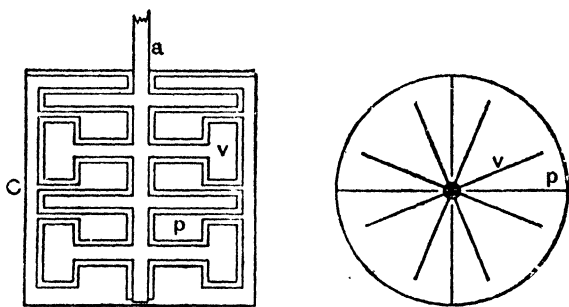

Fig. 170.

30 lb., attached by strings to the equal axles, *x x*, of two exactly similar and equal wooden pulleys, *p p* (1 foot in diameter). The motion thus communicated to the axles (2 inches in diameter) was transmitted by the pulleys, by means of cords, to the vertical wooden spindle, *r*, attached to the upper part of the paddle axle. To diminish friction as far as possible, the pivots of the pulleys were of steel, and rested each on two steel friction wheels. The handle, *h*, was used to wind up the weights into the position shown in the figure; by taking out the pin at *s* the spindle *r* could be disconnected from the axle, *a a*, and the weights could thus be wound up without causing rotation of the paddle.

With this apparatus Joule set himself to determine the quantity of heat produced by the expenditure of a given

amount of energy. For this purpose the water equivalent of C and its accessories was determined, and a known quantity of water was placed in C. The temperature of this water was given by a very delicate thermometer, t , reading to $\frac{1}{2000}$ th of 1° F. To prevent loss of heat from C it was placed on a wooden grating which touched the ground only at the four corners, and the axle, aa , which was of brass, was made in two pieces, joined at b by a piece of wood. These precautions helped to prevent loss of heat by *conduction*.

The weights were now wound up, the pin at s placed in position; and the temperature indicated by t having been read, the weights were allowed to fall to the ground (the distance being about 5 feet). This was repeated twenty times with as little delay as possible, and the final temperature of the water in C was then carefully taken. It was noticed that the velocity of the weights during the latter half of their fall was nearly uniform. The velocity was determined by repeated observation with some accuracy. The data now obtained, subject to a few corrections, served to determine the required relation.

Let m denote the mass of each weight, h the height of its fall, and v the velocity on reaching the ground; then

$$w = mgh - \frac{1}{2}mv^2$$

denotes in absolute units* the work done by each weight during each fall, for mgh is the loss of potential energy of each weight and $\frac{1}{2}mv^2$ is the gain in kinetic energy of each weight. Hence, if the weight fall n times, the total work done is given by $2nw$. Again, let θ denote the rise of temperature indicated by the thermometer t , and M the water equivalent of the apparatus C and the contained water; then

$$Q = M\theta$$

denotes the heat produced by the expenditure of a quantity of work denoted by $2nw$.

The quantity $2nw$ is subject to several corrections, the

* In gravitational units the equation reads $w = Mh - \frac{1}{2}\frac{M}{g}v^2$, where M is the weight of each weight.

most important of which is that due to the work absorbed by friction outside the water. To determine this correction, Joule disconnected the spindle from the paddle, and connected the weights by a single cord adjusted round r in such a way that as one weight descended the other was raised. A small weight, p , was then placed on one of the weights, and adjusted by repeated experiment until the velocity of descent was equal to that noted during an actual experiment. The weight p thus approximately represented the resistance due to friction and the work spent in overcoming it, for each descent is given by $w' = ph$. Hence, the work absorbed by friction during n descents is given by nw' , and the total work expended in the production of heat in the water is expressed by $W = 2nw - nw'$.

The quantity Q is also subject to an important correction due to the loss of heat by radiation during the thirty-five minutes occupied by the experiment. This was corrected by noting the rate of cooling for thirty-five minutes after the completion of the experiment. Let q denote the loss of heat by radiation; then $(Q + q)$, which may be denoted by H , expresses the total amount of heat produced by W units of work.

The object of Joule's experiments was to determine the relation between these two quantities. If H thermal units of heat are equivalent to W units of work, then one thermal unit of heat is obviously equivalent to $\frac{W}{H}$ units of work.

Joule determined the value of this ratio from a very large number of experiments. He found it practically *constant*, thus establishing the principle of equivalence between work and heat, and he gave as the mean value of the ratio

$$\frac{W}{H} = 772,$$

where W is expressed in foot-pounds and H in pound-degrees Fahrenheit. This means that one pound-degree Fahrenheit of heat is equivalent to 772 foot-pounds of work, or that if 772 foot-pounds of work are expended in

the production of heat the quantity of heat produced will raise one pound of water through one degree Fahrenheit.

The value of this ratio, $\frac{W}{H}$, is known as *Joule's equivalent* or the *mechanical equivalent of heat*, and is usually denoted by the letter *J*. It might also be called the *specific heat of water in mechanical units*.

243. Joule's later experiments on fluid friction. At a later date Joule carried out a final series of experiments for the determination of the mechanical equivalent of heat by the water friction method. These experiments, completed in 1878, were very similar to the earlier experiments

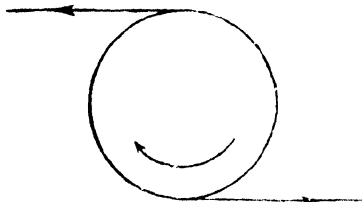

Fig. 171.

in method, but the work done in churning the water in the calorimeter was measured in a more satisfactory way. The calorimeter, instead of being fixed, was supported so as to be free to rotate with the paddle, but was prevented from so rotating by the action of a couple applied by cords attached to the circumference of the calorimeter (Fig. 171). In the figure the curved arrow shows the direction of rotation of the paddle, and it will be seen how the tensions in the cords attached to the calorimeter supply the couple necessary to prevent its rotation with the paddle.

The cords are applied to the calorimeter in a horizontal plane, but each cord passes over a pulley and hangs vertically, carrying a weight at the end. The weights are adjusted so as to keep the calorimeter in equilibrium against the couple, due to the rotation of the paddle. Thus if r denote the radius of the calorimeter at the section where the cords are applied, and M the mass attached to each cord, then $Mg \cdot 2r$ or $2Mgr$ is the moment of the couple applied by the cords, and when there is equilibrium this is equal to the moment of the couple against which

the paddle works. Hence the work done by the paddle in one revolution is $2 M g r \cdot 2 \pi$, or $4 \pi M g r$ (Art. 229).

In order that the calorimeter should be supported free, as far as possible, from all constraint preventing its rotation with the paddle, other than that due to the cords, it was at first carried by a bearing on the shaft of the paddle. The friction at this bearing, due to the weight of the calorimeter, was, however, found to be too great and too variable for the maintenance of equilibrium; and Joule found it necessary to take the weight of the calorimeter off the bearing by supporting it from below by a stand floating freely in a vessel full of water. By adjusting the quantity of water in the vessel, the supporting stand could be made to take practically all the weight of the calorimeter.

Figure 172, taken from Joule's paper in the *Transactions of the Royal Society*, shows the apparatus used in this series of experiments: *h* is the calorimeter, *vw* the hydraulic

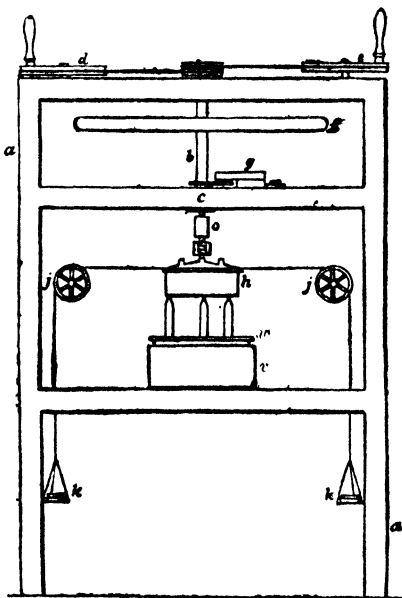

Fig. 172.

stand which supported the calorimeter. *d* and *e* the driving wheels, *f* a heavy fly-wheel to secure uniform speed of rotation, and *g* a counter for registering the turns made by the paddle. The apparatus was enclosed in a massive wooden box shown in section; the top of the box carried the driving wheels, the upper shelf by a bearing at *c* carried the weight of the paddle and fly-wheel, and the second shelf carried the hydraulic stand which supported the calorimeter.

The vertical section and the plan of the calorimeter and paddle are shown in Fig. 173. The general plan of construction is very similar to that of the calorimeter and paddle used in Joule's earlier experiments, but the paddle in this case has two sets of vanes, an upper set and a lower set, attached to the axis of the paddle in such a way that at the instant any paddle vane is in transit through a stationary vane, no other paddle vane is in this transit position, and that the transits during a complete revolution

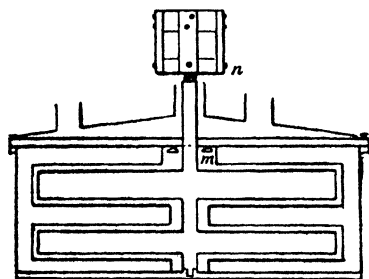

Fig. 173.

succeed each other at regular intervals. With this arrangement the resistance to the rotation of the paddle is more uniform, and equilibrium is more easily maintained.

In making an experiment the paddle was rotated for about 35 minutes, and the rise of temperature noted in the usual way. The heat produced

in the calorimeter could thus be measured, and the equivalent work was calculated in the way indicated above.

The values obtained by Joule in these experiments varied from 773.1 to 777.7 foot-pounds as the equivalent of one pound-degree Fahrenheit of heat. The mean result finally given by Joule as the result of his experiments was 773.4 foot-pounds at Manchester.

Joule also carried out a series of experiments on the friction of mercury, using a small *iron* apparatus similar to that described above. The results obtained were practically identical with those obtained with water, thus proving that *the equivalence of heat and work is independent of the nature of the apparatus by which the transformation is effected*. This conclusion was further confirmed by the results of some experiments with iron plates producing heat by their friction when rubbed together under mercury, and also by experiments on the compression and expansion of gases described in the next article.

Exp. 177. Make a rough determination of the value of the mechanical equivalent of heat. Obtain a *papier mâché* tube about 2 metres long and 5 cm. in diameter, and two corks which tightly fit the tube. Take a pound of small lead shot, pour them into a basin, and insert a thermometer in their midst. Wait ten minutes for the lead to acquire the temperature of the room. Take this temperature. Then pour the lead shot into the tube, close the tube and hold it vertical. Quickly invert it so that the shot fall the whole length of the tube. Repeat this operation 100 times, making sure that the shot fall the whole length of the tube each time. Then remove one cork from the tube and pour the shot into the basin and take their temperature as soon as possible.

From the rise of temperature calculate the heat developed, also calculate the work done.

Let m = mass in gm. of the shot,
 h = distance in cm. the shot fall each time,
 n = number of times the tube is inverted,
 s = sp. ht. of lead,
 t = rise of temperature in degrees C.

Then work done by gravity = $n(m \times h)$ gm.-cm.,
 heat gained by lead = mst calories.

$$\begin{aligned} \therefore J &= \frac{nmh}{mst} = \frac{nh}{st} \text{ gm.-cm. per calorie} \\ &= \frac{nh}{st} \times 981 \text{ ergs per calorie.} \end{aligned}$$

In the ordinary laboratory method of finding J the apparatus of Puluĵ is used. It comprises two steel cones, the outer one screwed to a revolving shaft, while the inner one, filled with mercury or water, is free to move according to the amount of friction between the two. The inner cone is kept stationary by means of a measurable couple, as in Joule's second method. The mercury or water becomes heated by friction between the two cones, and thus the ratio $\frac{w}{h}$ can be determined. It would be tedious to give here full particulars for carrying out the experiment, and most instrument makers supply full details with the apparatus.*

* See special pamphlet issued by W. G. Pye and Co., Grant's Works, Cambridge.

244. Joule's experiments on the Compression and Expansion of gases. When a gas is compressed, the work done on it in effecting the compression produces heat, which raises the temperature of the gas. Similarly, when a gas expands, it does work against the external pressure, and consequently there is an absorption of heat, which lowers the temperature of the gas. (**Exps. 175, 176.**)

Without experiment it cannot be assumed that *all* the work spent in compressing a gas is converted into heat, or that the heat absorbed during the expansion of a gas is equivalent to the work done. For example, when a steel spring is compressed, nearly all the work done in effecting the compression is spent in giving the spring potential energy, only a small fraction being spent in heating the steel. Similarly, when a gas is compressed the work done in compression may be partly spent in imparting potential energy to the gas, and partly in the production of heat.

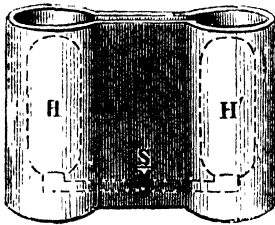

Fig. 174.

Joule had reason to believe that in some gases all the work done in compression or expansion had its equivalent in the accompanying thermal effects. He verified this assumption by the following experiment.

If a gas is allowed to expand into a vacuum *no* external work is done; and if any internal work is done—that is, if the potential energy of the gas is changed by the expansion—then an equivalent amount of heat will be absorbed, and the temperature of the gas will be lowered.

Accordingly, Joule took two reservoirs, H, H' (Fig. 174), communicating by a tube fitted with a stopcock at S. The reservoir H contained air under a pressure of 22 atmospheres. H' was completely exhausted of air. These reservoirs were immersed in a large vessel, so constructed that a small quantity of water sufficed to cover them. The temperature of the water was then taken, and the stopcock opened. The gas in H suddenly expanded into H', but after stirring no change in the temperature of the

water as a whole could be detected, thus showing that very little or no internal work was done.

Later experiments by Joule and Thomson on this subject showed that when a gas expands without doing external work a slight absorption of heat takes place, which is smaller the more nearly the gas conforms to Boyle's law, and would be zero for a perfect gas conforming exactly to that law.

Assuming then that, for air, the external work done during expansion is equivalent to the heat absorbed, it is evident that this fact may be readily adapted to the experimental determination of the equivalence of heat and work.

Joule adopted this method. In one of his experiments he employed a reservoir containing air under a pressure of 22 atmospheres, and immersed in water contained in a large calorimeter. The air escaped from the reservoir through a stopcock constructed to regulate the velocity of its flow, and through a long coil of lead tubing, to the exterior, where it was collected in a large vessel under the pressure of the atmosphere. The stopcock and tubing were both immersed in the calorimeter, so that the air arrived at the exterior at the temperature of the calorimeter, and without any appreciable velocity.* The temperature of the water in the calorimeter was taken before and after the expansion; and the fall of temperature, multiplied by the water equivalent of the calorimetric apparatus, gave the heat, H , absorbed by the expansion of the air.

To determine the work, W , to which this is equivalent, it is necessary to calculate the external work done by the gas during its expansion. Now the gas expands against the pressure of the atmosphere, which is constant during an experiment of short duration; hence, by Art. 230, the work W done by the gas is equal to the product of the atmospheric pressure, P , and the volume, V , of the air

* Had the air been allowed to expand freely into the air, it would have carried away energy in the form of kinetic energy, and thus the fall of temperature would have indicated a greater absorption of heat than that equivalent to the external work done.

collected after escaping from the reservoir and measured at atmospheric pressure.

That is

$$W = P V,$$

and then

$$W = J H,$$

from which J can be calculated.

From several experiments, of which the one described above is one of the simplest, Joule deduced results which agreed closely with those he had previously obtained by frictional methods.

245. Calculation of Joule's equivalent from the values of the two specific heats of gases. We have already, in Art. 97, referred to the fact that the specific heat of gases at constant pressure is greater than that at constant volume. This is evidently due to the fact that when a gas is heated at constant pressure it expands, and part of the heat absorbed is expended in doing external work, *the remainder* being spent in increasing the temperature of the gas. When, however, a gas is heated at constant volume, *no* external work is done, and *all* the heat absorbed is spent in increasing the temperature of the gas. From this it appears that, since practically no internal work is done (Art. 244), the difference between the two specific heats should be equivalent to the external work done during the expansion, at constant pressure, of one gramme of the gas for one degree rise in temperature.

That is, if

s_p denote the specific heat at constant pressure,

s_v the specific heat at constant volume,

w = the work done during expansion of 1 gm. of gas per 1° C. rise in temperature, and

h the heat equivalent of this work,

$$s_p - s_v = h = \frac{w}{J}.$$

Hence, if s_p , s_v , and w are known J can be calculated.

Regnault was the first to determine s_p . His value is 0.2374 (Art. 97); a later and probably more correct value for the value of s_p at 20° C. is 0.2410. Joly was the first to determine s_v . His value is 0.1715 (Art. 165). Taking

the values 0.2410 and 0.1715, it follows that $h = 0.0695$. To calculate w we require the increase of volume of 1 gm. of air per 1°C . rise of temperature and the pressure at which this occurs.

Take the pressure as 76 cm. of mercury at 0°C ., in absolute units, this is $76 \times 13.6 \times 981$, or 1.014×10^6 dynes per sq. cm.

At 0°C . and a pressure of 76 cm. of mercury 1 litre of air weighs 1.293 gm. (Regnault), therefore the volume of 1 gm. of air at this temperature and pressure is $\frac{1000}{1.293} = 773$ c.c., and the increase of volume for 1°C . rise

of temperature = $\frac{773}{273} = 2.83$ c.c.

Hence

$$w = 1.014 \times 10^6 \times 2.83 \text{ ergs.}$$

$$\therefore J = \frac{1.014 \times 2.83}{0.0695} \times 10^6$$

$$= 4.18 \times 10^7 \text{ ergs per calorie.}$$

The first calculation of this nature was made by Mayer in 1842. He assumed, from some crude experiments of Gay Lussac, that no internal work is done in the expansion of a gas, and then, from a knowledge of Regnault's value of s_p and value of the ratio $\frac{s_p}{s_v}$,* he deduced s_v , and finally the mechanical equivalent of heat. Owing to inaccurate data his value was far from the truth.

It is also obvious that if the values of J and s_p are known the value of s_v can be obtained by the calculations given above.

* The ratio $\frac{s_p}{s_v}$, usually denoted by γ , can be determined by several independent methods. Clement and Desormes found it from experiments on the quick compression and expansion of gases, and Rankine calculated it from the formula for the velocity of sound, viz.

$$v = \sqrt{\gamma \frac{\text{Pressure of the air}}{\text{Density of the air}}}$$

The value of γ for air is 1.404. (See also Art. 263.)

246. Rowland's experiments. Joule's work on the mechanical equivalent of heat was considered so important that Rowland, of Baltimore, thought it desirable to apply a number of corrections to the data of Joule's experiment, and also to repeat and extend the experiments with the most laborious attention to the details of observation and correction of errors.

The more important corrections applied by Rowland to Joule's work included—

1. The reduction of the temperatures recorded in the experiments to air thermometer temperatures. This was done by direct experiment with Joule's thermometers which were available for the purpose.

2. The correction for the variation of the specific heat of water with the temperature.

3. The correction of all weighings for the buoyancy of air.

The relative value of these corrections is indicated by the following particulars of the corrections applied to one of Joule's 1878 results:—

Joule's value	774.6
Thermometer correction	+	3.7
Specific heat correction	+	.2
Reduction to vacuum correction				-	.9
Corrected value	=	777.6

In the experiments devised and carried out by Rowland the method of Joule's later experiments was adopted. The object in view in designing the apparatus was to reduce to the lowest limit all the possible sources of error, and to provide for the correction of unavoidable sources of error with maximum of accuracy.

In Joule's experiments the unsatisfactory element was the large value of the cooling correction relative to the total rise of temperature during an experiment, for this caused an error in the determination of the cooling correction to appear as an appreciable error in the value of *J*. Rowland improved on this by arranging, by the expenditure of much more power in driving the paddle, to get a much larger rate of rise of temperature. In this way the

percentage value of the cooling correction was greatly reduced, for with a given rise of temperature the cooling correction is directly proportional to the time in which the rise takes place. Thus in some of Joule's experiments 1° C. rise of temperature took place in about 1.5 hours; whereas in Rowland's experiments a rise of 1° C. took place in less than two minutes; the cooling correction in Rowland's experiments was therefore only about $\frac{1}{60}$ th as great as in Joule's experiments.

In Rowland's apparatus the calorimeter was suspended by a wire. The paddle shaft entered the calorimeter from below and was driven by a steam engine. The cords carrying the balancing weights were attached to the rim of a wheel rigidly connected with the calorimeter. The total balancing couple was thus partly due to the balancing weights and partly due to tension of the wire. The calorimeter and paddle were similar to Joule's, but the number of paddle vanes was increased and arranged so that the thermometer could remain in the water all the time, and care was taken to circulate the water past the thermometer bulb. The calorimeter was surrounded by a jacket of constant temperature to ensure accurate corrections for cooling of corrections, and Rowland gives the mean value of J from his own experiments as 427.52 gramme-metres at Baltimore per calorie at 14.6° C.

The mean result deduced by Rowland from Joule's own experiments is 426.75 gramme-metres at Baltimore per calorie at 14.6. These results differ by less than 0.2 per cent. and give the value of J as very nearly 4.19×10^7 ergs for 1 gram-degree Centigrade at about 15° C.

Rowland's experiments show that the variation of the specific heat of water with temperature has a bearing on the value of J that comes well within the limits of observation. From results obtained at different temperatures between 5° C. and 36° C. Rowland was led to conclude that the specific heat of water passes through a minimum at a temperature not far from 30° C., and this conclusion has subsequently been justified by experiments which go far to show that the specific heat of water reaches a minimum at 40° C. (See Art. 100.)

In 1892 Miculescu published the results of a determination of J by a direct method similar to that of Joule and Rowland. The calorimetric measurements were, however, made by a null method, the calorimeter being kept at a stationary temperature by the flow of water between its double walls, and the amount of heat developed in a given time measured by determining the rate of flow of the water, and the difference between the temperatures of the water at entrance and exit. Miculescu gives 426.7 as the number corresponding to Rowland's value, 427.52, given above.

247. Hirn's experiments. I. Hirn found the value of J by an impact experiment. A large piece of iron was suspended by strings, so that when the strings were vertical the iron just rested against a thick lead * cup fitting in the end of a very large stone, suspended similarly to the iron. The iron was then drawn aside, and the height it was raised measured. It was then released. At the impact the energy, W_1 , spent by the experimenter in lifting the iron up when drawing it aside, less the energy, W_2 , spent against gravity in lifting up the stone and iron after the impact, was converted into heat. The temperature of the lead was taken before the impact. After the impact the lead cup was removed from the stone, water at 0°C . was poured into the cup, and its final temperature taken. From these readings the heat, H , generated by the impact was calculated. Thus J could be evaluated from $W_1 - W_2 = JH$. His result was 425 gram-metres per calorie.

II. In all the experiments described so far work has been transformed into heat. Hirn performed a striking experiment, in 1857, with a steam engine, in which heat was transformed into work. He measured the quantity and pressure of the steam entering the cylinder. From these he calculated H_1 , the heat supplied in a given time. When the still hot steam left the cylinder he made it pass through tanks of cold water, and so measured the amount

* Lead was chosen because of its inelasticity. There is little rebound from lead, and little sound is produced.

of heat, H_2 , remaining in it when it left the cylinder. He also measured the heat, R , lost by radiation from the steam boxes and pipes. The difference, $H_1 - H_2 - R$, is equivalent to the work done by the engine in the given time.

The work done per stroke was measured by an indicator diagram (Art. 262) in dynamical units. The mean effective pressure on the piston read off from the diagram multiplied by the cross-section of the cylinder and the length of the stroke of the piston gave the work done per stroke, and this multiplied by the number of strokes in the given time gave W , the work done for an amount of heat $H_1 - H_2 - R$, whence

$$J = \frac{W}{H_1 - H_2 - R}.$$

Hirn's value of J by this method was 420 gram-metres per calorie.

248. Heat developed by a current in a wire. Joule's law. If a current of C amperes passes through a wire, and the resistance of the wire is such that the potential difference between the ends of the wire is V volts, it follows from Art. 235 that since the wire is merely an inert portion of a circuit the electrical energy turned into heat energy in the wire is $V C$ joules per second. It is, however, more usual to express the heat energy in terms of the resistance and the current. If R is the resistance of the wire, we have, by Ohm's law, $V = C R$ and therefore $V C = C^2 R$.

Our result is, therefore,

$$\left. \begin{array}{l} \text{Heat generated per second in a wire of} \\ \text{resistance } R \text{ ohms by a current of} \\ \text{ } C \text{ amperes} \end{array} \right\} = C^2 R \text{ joules} \dots\dots (1)$$

This is known as *Joule's law*; from it, it is clear that *for the same current the heat developed in a given time is proportional to the resistance, while for the same resistance it is proportional to the square of the current.*

From (1) it follows that the heat developed in a time t in a wire of resistance R ohms by a current of C amperes

is $C^2 R t \times 10^7$ ergs. Dividing this by J we get $\frac{C^2 R t \times 10^7}{J}$ calories. Hence, if we measure in calories the heat developed we have a means of finding J .

Exp. 178. *Make a Joule's calorimeter and find the value of J .* Take a thin copper calorimeter and fit it with a cork (Fig. 175). In the figure the calorimeter is made transparent in order to show the interior.

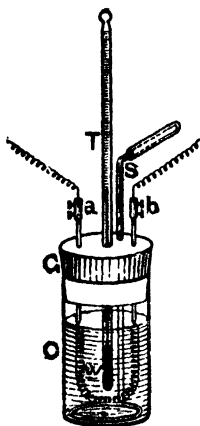

Fig. 175.

Bore four holes through the cork, two quite small, to admit lightly thick copper wires, and two larger, one to admit an accurate thermometer* and the other a stirrer. To the lower ends of the thick copper wire solder the ends of a spiral of silk-covered German silver† wire, enough wire being taken for the coil to have a resistance of 10 to 20 ohms. The resistance at the mean temperature of the experiment should be accurately known. To the upper end of the copper leads attach binding screws and connecting wires. Mount the calorimeter in a heat

shield as in specific heat work (Art. 88).

Make up a circuit as in Fig. 176, where G is a tangent galvanometer whose constant is known, B a battery of 5 Grove's cells, C Joule's calorimeter, K a commutator, R a carbon rheostat. Put a weighed quantity of water into the calorimeter, fit the cork and take the temperature of the water.

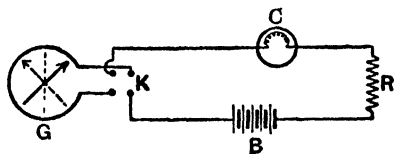

Fig. 176.

Now complete the circuit, and adjust R to get a reasonable deflection of the galvanometer and keep the current steady

* It should be graduated to fifths or tenths of a degree.

† The resistance of German silver does not alter much with temperature.

at this mark. The temperature of the water gradually rises. Stir well. Note carefully the time it takes to rise successive degrees.

While the calorimeter is colder than the air it is gaining heat from outside. When warmer than the air it is losing heat. We shall get our best result if we take the rate of rise of temperature when the temperature of the calorimeter is equal to that of the air. To get this plot a graph between temperature and time, smooth out irregularities, and then calculate the correct slope of the graph when the temperature is equal to that of the air. Calculate the total water equivalent of calorimeter and its contents. Then if

M is this water equivalent in gm.,

θ the rise of temperature per t seconds, calculated as explained above,

$$\frac{M \theta}{t} = \text{heat developed per second.}$$

Obtain C from the reading of the tangent galvanometer ($C = \frac{5 H r}{\pi n} \tan \delta$, with the usual notation) and evaluate $C^2 R$.* Then calculate J from the equation

$$J = \frac{C^2 R t \times 10^7}{M \theta}.$$

In a variation of this experiment an ordinary incandescent 16 c.p. electric lamp is used and immersed upside down in the water of the calorimeter.

EXAMPLE.—A steady current of $1\frac{1}{2}$ ampere was passed through a resistance of 15 ohms, and in 120 seconds it raised the temperature of 240 gm. of water exactly 5° C. Find the mechanical equivalent of heat.

We have

Heat developed by the current

$$\begin{aligned} &= C^2 R t \times 10^7 \\ &= \frac{25}{9} \times 15 \times 120 \times 10^7 \text{ ergs.} \end{aligned}$$

* Since the resistance of a wire alters with temperature its value, R , should be measured at the mean temperature of the experiment.

But this is equal to 240×5 calories,

$$\begin{aligned} \therefore J &= \frac{25}{4} \times \frac{15 \times 120 \times 10^7}{240 \times 5} \\ &= 4\frac{1}{8} \times 10^7 \text{ ergs per calorie.} \end{aligned}$$

Within recent years two very careful determinations of J have been made by Principal E. H. Griffiths and Professor Schuster, by the calorimetric determination of the heat developed in a wire carrying a current by the expenditure of a known quantity of energy measured in electrical units.

The absolute values of the electrical units involved are probably known with greater accuracy than the value of J , and with proper precautions the method gives good results. Griffiths gives 4.194×10^7 ergs as the mean value of J at 15°C ., the scale of temperature being that of the nitrogen thermometer. Schuster and Gannon give 4.191×10^7 ergs, with the same reference conditions, as the mean of their results.

249. The value of J . The latest figures for J are given in the following table:—

778 foot-pounds per water-pound-degree Fahrenheit.

1400 foot-pounds per water-pound-degree Centigrade.

427 kilogrammetre or 427 gramme-metres per water-gramme-degree Centigrade.

4.19×10^7 ergs per water-gramme-degree Centigrade.

10^7 ergs is often called a joule. Hence we may also write—

$J = 4.19$ joules per water-gramme-degree C.

or 4.19 joules per calorie.

250. The first law of thermo-dynamics. This law asserts the equivalence of heat and work in a definite ratio determined by experiment. It may be stated thus:—

When work is transformed into heat, the quantity of heat produced is equivalent to the quantity of work expended in its production; and conversely when heat is transformed

into work, the quantity of work produced is equivalent to the quantity of heat expended in its production. That is, in both cases,

$$W = JH,$$

where W denotes any definite quantity of work, H the equivalent quantity of heat, and J the ratio of these two quantities. This ratio is known as **Joule's equivalent**, or the **mechanical equivalent of heat**, or the **specific heat of water in mechanical units**. The value of J in the different systems of units is given above.

251. Conservation of energy. As we have already mentioned in Art. 237, it has been proved that whenever energy in one form disappears it is always replaced by an exactly equivalent amount of other forms of energy. Hence, when all the forms of energy are taken into consideration—

(1) *The total amount of energy in the universe is absolutely unalterable, i.e. no energy is ever created or destroyed.*

(2) *The various forms of energy may, though not always at will, be converted one into another.**

Energy may be transferred from one body to another, or transmuted from one kind to another, but the energy lost by one body is gained by other bodies, and *vice versa*.

The principle contained in the above propositions is known as the **Conservation of energy**.

252. Thermo-electric currents. If a circuit is made up with two wires, F and C (Fig. 177), of different metals joined together at their ends, it is found that a current can be produced in the circuit by heating one of the junctions, or, more generally, by establishing, in any way, a difference of temperature between the two junctions. Such

* In nearly all operations some energy is wasted in friction, etc., going into the form of heat energy; as a rule, very little of this energy is recoverable by human agencies, and it is therefor said to be *dissipated*. In any store of energy that portion which can be used for actual mechanical work is often spoken of as the *available energy*.

junctions are termed thermo-electric *elements* or *couples*. The existence of this current can be shown by including a galvanoscope in the circuit.

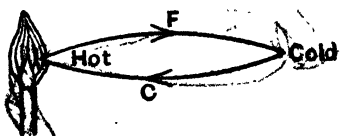

Fig. 177.

The current is maintained so long as this difference of temperature is maintained, and varies in direction and strength as this difference varies.

Exp. 179. Take pieces of iron and copper wire of about equal lengths (say, 2 feet), and join one end of each to a sensitive galvanoscope. Twist the other ends tightly together. Warm this junction with the hand or a flame. There is a deflection: thus indicating the passage of a current. Cool the junction in ice: the deflection is reversed. Find by experimenting with a voltaic cell joined to the galvanoscope the relation between the sign of the deflection and the direction of the current in the circuit. With moderate temperatures you will find that the current always flows from copper to iron across the hot junction.

Similar results are obtained with a couple formed with wire or rods of any two metals, but the direction and magnitude of the currents are different for different metals.

If a thermo-electric couple is maintained with its junctions at different fixed temperatures, as in the case of the copper-iron couple described above, it is found that, in general, it absorbs heat at the hot junction and gives out heat at the cold junction. There is also, in general, absorption and evolution of heat in the wires of the couple; but, taking the circuit as a whole, there is always more heat absorbed than evolved, so that the circuit absorbs energy in the form of heat and transforms it into the electrical energy of the current produced in the circuit. This electrical energy could be made to do mechanical work in turning an electro-motor or chemical work in effecting electrolysis. In the ordinary circuit, however, as in **Exp. 179**, it is finally dissipated in the circuit as heat.

Under ordinary conditions thermo-electric currents are very weak, and thermo-electric couples cannot be economically used in practice for the development of current.

contact between $X Y$ and a wire $W Z$ permanently joined to G . If the balance occurs at O , the middle point of $X Y$, then since $P = Q$

$$T + D + X O = D' + R + O Y,$$

and since $D = D'$ and $X O = O Y$,

$$T = R.$$

If balance occurs at a point S , say, to the right of O ,

$$T + D + X S = D' + S Y + R,$$

$$\therefore T = R - 2 O S.$$

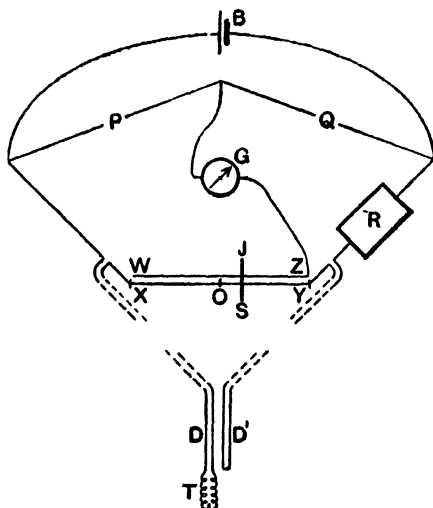

Fig. 201.

The Resistance of 2 cm. of bridge wire is chosen as the unit of resistance, so that the resistance of the thermometer is equal to the box resistance (expressed in these units*) plus the distance in centimetres that S is to the left of the middle point of $X Y$.

* A form of bridge specially designed for this work and complete with resistances is usually employed.

The tubes of thermometers designed for higher temperatures, say, up to 1200°C ., are made of glazed porcelain and the leads are made of thick platinum wire. If, however, only the tip of the tube need be in the hot region, this part only of the tube need be porcelain, the rest may be steel; the leads also need only be platinum in the hot part and copper in the cooler part of the tube.

Callendar and Griffiths define temperature on a platinum thermometer of this kind in the following way:—

Taking the simple formula

$$R_t = R_0 (1 + \alpha pt),$$

where pt is *platinum thermometer temperature*, then if R_{100} is the resistance of the wire at the temperature of steam from water boiling under normal pressure, R_0 the resistance at the temperature of melting ice, and R_t the resistance at any other temperature pt , then

$$pt = \frac{R_t - R_0}{R_{100} - R_0} 100.$$

The value of $R_{100} - R_0$ is called the *fundamental interval* of the thermometer.

Temperatures determined in this way will not of course correspond with air-thermometer temperatures; but Callendar, and later Griffiths, found that the difference, d , between the two scales is expressed for a wide range of temperature by

$$d = T - pt = \delta \left\{ \left(\frac{T}{100} \right)^2 - \frac{T}{100} \right\}, \dots\dots\dots (1)$$

where T denotes the air-thermometer temperature on the Centigrade scale, and δ a constant depending on the chemical constitution of the wire and may be determined once for all for any given thermometer.

The value of d is determined by observation of the resistance of the thermometer at three known temperatures, the points usually selected for this purpose being 0°C . and 100°C ., the freezing and boiling points of water respectively, and 444.5°C ., the boiling point of sulphur at normal pressure.*

* Instead of taking the sulphur point the fact that the resistance of pure platinum vanishes at about -240°C . may be used,

The formula (1) has been shown to be strictly true up to 1000° C.

The value of the factor δ for the wire supplied by the Cambridge Scientific Instrument Co. may be taken as 1.50, so that equation (1) may be given in the form

$$T = pt + 1.50 \left[\left(\frac{T}{100} \right)^2 - \frac{T}{100} \right]$$

or
$$T = \left(\frac{5000}{1.5} + 50 \right) - \sqrt{\left(\frac{5000}{1.5} + 50 \right)^2 - \frac{10000 pt}{1.5}}.$$

Tables can be obtained showing the air-scale temperatures corresponding to every 5 degrees of the platinum scale between 0° C. and 1200° C. thus:—

Platinum Temperatures.	Air Scale Temperatures.
.....
600	654.4
605	660.5
610	666.7
615	672.7
...

If the formula $R_t = R_0 (1 + aT + bT^2)$ is used the value of R_T when $T = 0^\circ \text{C.}, 100^\circ \text{C.}, 444.5^\circ \text{C.}$, should be found and a curve plotted showing the relation between R_T and T . A convenient fixed point, higher than the sulphur point, is the temperature of melting potassium sulphate, 1070° C.

One great advantage of this form of thermometer is that the addition of compensating leads renders the indications of these thermometers independent of the depth of immersion of the thermometer in the hot region as long as the bulb is wholly immersed and of the distance of the thermometer from the temperature measuring apparatus.

Apparatus has also been designed to make the Wheatstone Bridge reading indicate temperature straight away, and this apparatus is so simple that an ordinary workman can use it.

Temperature can also be continuously recorded by these thermometers when connected up to a Callendar's patent recorder. The recorder, actuated by clockwork, automatically balances the resistance of the thermometer by resistances contained in the instrument, and a pen records the actual temperature on a sheet of paper fixed to a revolving drum.

These thermometers have important and extensive applications in all forms of industry where temperature is an important factor, from cold-storage chambers and hospitals to annealing furnaces and steel-casting.

Readings correct to within $\frac{1}{10}^{\circ}$ C. can be taken by these thermometers from 0° C. as far up as 1300° C., the sensitiveness remaining approximately constant.

274. Thermo-electric thermometers. We saw in Art. 252 that when an electrical circuit was made of wires of two different metals and the junctions of the metals were kept at different temperatures, a current is set up in the circuit. This current is roughly proportional to the difference of the junction temperatures, so that a measurement of the current by a galvanometer serves as a measurement of the junction temperatures.* For a moderate difference of temperatures the current is greatest when the metals are antimony and bismuth. Iron and nickel, copper and the alloy constantan,† also give currents of the same order.

For high temperature work, however, these metals are not sufficiently durable, and for work up to 1400° C. the junction metals should be platinum and an alloy of platinum with 10 per cent. iridium, and for work up to 1600° C. platinum and an alloy of platinum with 10 per cent. rhodium. The copper-constantan junction may be used up to 500° C., and the iron-nickel junction below 300° C.

* It is not necessary that the circuit should consist of just the two metals and the two junctions. It may be completed through wires of other metals, galvanometers, etc., as long as the junctions of the two metals with the remaining part of the circuit are at the same low temperature.

† Constantan or eureka is an alloy of copper and nickel.

The form of instrument designed by the Camb. Sci. Inst. Co. for work up to 1400°C . is shown in Fig. 202. Two fine wires ($\cdot 6$ mm. diameter) of the metals employed are threaded through fine porcelain tubes. At the lower end the wires are fused together, and it is this junction that is exposed to the heat. The wires are placed in a larger porcelain tube, and a wooden cap to this tube bears binding screws which are joined internally to the junction-wires and externally to the temperature-measuring apparatus. The other junction of the metals should for strict accuracy be kept at a constant low temperature, but as the instrument is usually used for the measurement of very high temperatures, it is sufficient if the other junctions are kept fairly cool.

It is really the electromotive force in the circuit that depends on the nature of the metals and the temperatures; the current is simply the quotient of the electromotive force by the resistance of the circuit. For approximate work we may assume that the resistance of the circuit does not alter and simply measure the current by a galvanometer. The error made is lessened if the galvanometer is of such high resistance that the variation of the resistance of the metals composing the hot junction are negligible. For very accurate work, however, the electromotive force should be measured on a potentiometer.

The formula connecting the electromotive force with the temperature is proved in most text-books of magnetism

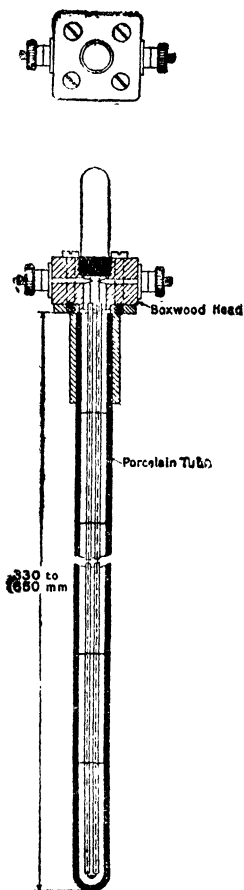

Fig. 202.

and electricity.* It is

$$E \propto (T - T_1) \left(\frac{T + T_1}{2} - T_n \right),$$

where E is the E.M.F. in the circuit when the low and high junction temperatures are $T_1^\circ \text{C.}$ and $T^\circ \text{C.}$ and the neutral point of the metals is T_n . In practice thermocouples are only used for very high temperatures, and an approximate formula which may be used with the thermocouples usually employed when T_1 is nearly 0°C. is

$$\log. E = A \log. T + B,$$

where A and B are constants depending on the metals employed.

Another formula which is sometimes used is

$$E = P + QT + RT^2,$$

where P, Q, R are constants. The formulæ do not quite agree, and it is best in practice to standardise each particular thermocouple by finding its E.M.F. at known temperatures. The E.M.F. generated by the platinum-platinum iridium junction is approximately 15 microvolts† per degree C. and that by the platinum-platinum rhodium junction 10 microvolts per degree C.

These couples will give temperatures right to within 1°C. from 1000°C. up to the melting point of platinum, 1710°C. One advantage which they have over resistance thermometers is that they measure the temperature *at a point.*

Temperatures below 300°C. cannot be conveniently measured by thermocouples composed of the platinum metals, as the E.M.F. generated is so small. For such low temperatures a nickel-iron junction which gives 30 microvolts per degree difference between the junction-temperatures may be used. It would, however, be more accurate to use a resistance thermometer.

In commercial work a high resistance galvanometer is used with thermocouples, and it can be made direct reading, and also by a clockwork arrangement to give con-

* See *Higher Text-book of Magnetism and Electricity*, § 217.

† One microvolt is one millionth of a volt.

tinuous records. The measuring instrument may be placed at a great distance from the couple, as the resistance of the leads is practically negligible in comparison to the high resistance of the galvanometer.

275. Radiation pyrometers. In all the forms of pyrometer yet described there is some part which has to be inserted in the region whose temperature is under observation. This disadvantage is overcome in the Fery radiation pyrometer, which is used for measuring the temperatures

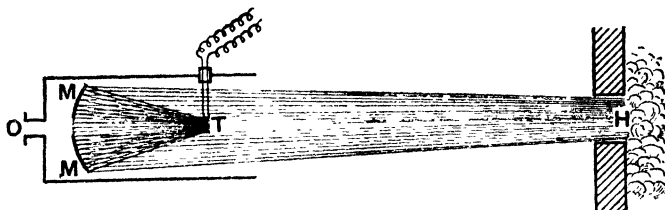

Fig. 203.

of furnaces and other very hot bodies. A hole H (Fig. 203) is made in the side of the furnace, and the radiation coming from this hole impinges on a concave gilt mirror MM, set up in a short open tube placed some distance away, and sighted on H by observation through a hole O behind the mirror. The mirror reflects it to a minute copper-constantan thermocouple T arranged as a disc and placed at the conjugate focus to H. The current generated by this thermocouple is measured by a galvanometer, which may be graduated to give straight away the temperature of the furnace.

The temperature of the thermocouple does not rise above 100°C ., but the instrument can be used to measure very high temperatures. It is not accurate for temperatures below 600°C . It may be used to measure the effective temperature of the sun (7800°C .) by the simple expedient of just pointing the instrument at the sun and reading the galvanometer. The principle on which the instrument is based is that of Stefan's law (Art. 214),

namely, that "the radiant energy emitted by a fully radiating body is proportional to the fourth power of the absolute temperature of the body." If the galvanometer attached to the pyrometer has a uniformly graduated scale, and the absolute temperature T_1 corresponding to a reading R_1 is known, then the absolute temperature T_2 corresponding to a reading R_2 is given by

$$T_2 = T_1 \sqrt[4]{\frac{R_2}{R_1}}$$

It is here assumed that the fourth power of the temperature of the cool junction is negligible compared with T_1^4 or T_2^4 .

In a simpler form of the Fery radiation thermometer the thermocouple T and galvanometer are replaced by a small bimetallic spiral which actuates a long pointer moving over a scale graduated directly in degrees. The principle is that of the Breguet thermometer (Art. 46).

With both instruments the readings are independent of the distance from the mirror to the source of heat, provided that the image of the source produced by the mirror is larger than the receiving disc T .

In some other forms of optical pyrometer comparison is made between the intensity of the light given out by the hot body and by another hot body of known temperature.

276. Low temperature measurements. For low temperature measurements we may use either alcohol thermometers (freezing point of alcohol = -130°C .) graduated by comparison with the standard gas thermometer or platinum resistance thermometers. The platinum bulb may be contained in a brass tube, and copper leads may be used. A convenient fixed point is the temperature of boiling liquid oxygen at normal pressure, which is -182.2°C .

EXAMPLES XVIII

1. How is an air thermometer constructed and how is it used? What means have we besides the air thermometer of measuring temperatures between 400°C . and 1800°C . ?

2. Describe the essential features of the measurement of temperature by Callendar's platinum thermometer.

3. The resistance of a certain platinum thermometer in melting ice is 592.387 units. In steam at 100° C. it is 821.922 units. When its resistance is exactly 640 units what is its temperature?

4. The resistance of a certain platinum thermometer was measured in melting ice (0° C.), steam (99.9° C.), sulphur vapour (444.2° C.), and was found to be 317.1, 451.6, 784.8 units respectively. Express the ratio $\frac{R_t}{R_0}$ as a formula $1 + at + bt^2$ and find the value of δ for this particular thermometer.

5. Describe how a thermocouple may be used to measure temperature. How would you use a thermocouple to find the temperature of the bottom of the sea?

EXAMINATION QUESTIONS ON THE MECHANICAL EQUIVALENT OF HEAT, ETC.

1. Heat was at one time supposed to be a substance called caloric; what experiments would you bring forward to show that this view is untenable?

2. Explain where the energy goes when you expend it in (a) winding up a watch, (b) lifting a stone from the floor and placing it on a shelf, (c) riding a bicycle up hill, (d) rowing a boat on a still pond, (e) rowing a boat up-stream.

3. Explain the terms "Conservation" and "Transmutation of Energy." Illustrate your answer by reference to an electric light circuit, a gas engine being used to drive the dynamo.

4. When a gas expands heat has to be supplied if the temperature is to be kept constant. Why is this?

5. Briefly describe one of the ways in which the amount of energy equivalent to a given amount of heat has been determined. Explain what is meant by expressing the specific heat of water in ergs per gramme, and state its value either in these units or in gravitation foot-pounds per pound.

6. Describe the experiments by which Joule was led to the conclusion that no change of temperature occurs when air expands without doing mechanical work. Is this conclusion strictly accurate? If not, how must the statement be modified?

7. Distinguish between the specific heat of air under constant pressure and its specific heat under constant volume. Show how, from a knowledge of the two specific heats of air, together with its density at given pressure and temperature, the value of the mechanical equivalent of heat may be computed.

8. A pound of coal in burning can raise 8,000 lb. of water 1° C. Used in an engine the coal supplies 1,400,000 foot-pounds of work per pound burnt. What fraction of the heat is transformed to work? (Mechanical equivalent = 1,400, using foot-pounds and degrees Centigrade.)

9. What is the efficiency of an engine which consumes 28 lb. of coal in drawing a train one mile against a resistance equal to the weight of $1\frac{1}{2}$ tons, the calorific power of the coal being such that one pound is capable of converting 16 lb. of boiling water into steam at the same temperature?

10. Water at 15° C. and 1000 atmospheres pressure is passed through a porous plug and escapes at one atmosphere pressure. Calculate the temperature of the escaping water.

11. On passing a current of 1 ampere through a piece of platinum wire it is found that its temperature rises 10° C. above that of the surrounding objects, which are at 0° C. Assuming that the rate of loss of heat is proportional to the difference of temperature, calculate the temperature of the wire when a current of 2 amperes is passed through it. The temperature coefficient of the resistance of the wire may be taken to be 0.004 of the resistance at 0° C.

12. A current of water of 0.8 gm. per second is passed through a glass tube of 50 cm. in length, along the axis of which a platinum wire is stretched. The wire is heated by an electric current. The current-strength is 2 amperes, and the difference of potential between the ends of the wire is 16 volts. Calculate the rise of temperature of the water as it passes through the tube.

13. Find the number of watts in one horse-power given that 1 foot = 30.48 cm., 1 lb. = 453.6 gm., $g = 981$ cm.-sec.².

Electrical energy is sold at 4d. per kilowatt hour. The mechanical equivalent of heat given by burning of coal worth 4d. is 10^6 foot-lb. Compare the prices of the two forms of energy. Why is electrical energy so much dearer than coal energy?

14. Mention the different methods which are used for measuring temperature, and discuss their relative merits (a) for measuring temperatures between 1000° C. and 2000° C., (b) for measuring temperatures between 0° C. and 200° C., (c) for measuring the temperature of a patient in hospital.

15. When temperatures are expressed on the centigrade scale, the latent heat of fusion of ice is represented by 80, and the mechanical equivalent of heat by 423.9 (gramme-metres). Express the same quantities on the Fahrenheit scale, and explain why one is represented by a larger and the other by a smaller number.

CHAPTER XIX.

LIQUEFACTION OF GASES.

277. Conditions for liquefaction. Every gas will, if its temperature is sufficiently lowered, at some definite pressure condense to the liquid state. If, however, its temperature is not below the critical temperature, no amount of pressure will reduce it to a liquid (Art. 257). The first requisite, then, in liquefying a gas is to cool it below its critical temperature; once below this temperature, the gas may be liquefied by the application of pressure only, and the varying methods used by different investigators depend on the different means adopted to obtain the requisite amount of pressure and lowering of temperature.

278. Early experiments. The first well-authenticated successful attempt to liquefy gases was made in 1806 by Thomas Northmore, who, using a brass condensing pump and glass receivers, succeeded in liquefying chlorine and sulphur dioxide. His work was passed over unnoticed, however, and it was not till 1823 that the next step was taken, when Faraday succeeded in liquefying several of the more easily condensible gases.



Fig. 204.

In Faraday's earliest experiments the materials from which the gas was to be generated were placed in one limb of the V-shaped tube (Fig. 204), and the other limb sealed off and placed in a freezing mixture. Heat was then

applied to the limb containing the reagents, when the gas distilled over and condensed under the influence of its own pressure in the other limb.

About 1835 Thilorier succeeded in preparing large quantities of liquid and solid carbon dioxide by similar means. A large gun-metal retort, A (Fig. 205), swinging upon trunnions, contained sodium bicarbonate mixed with

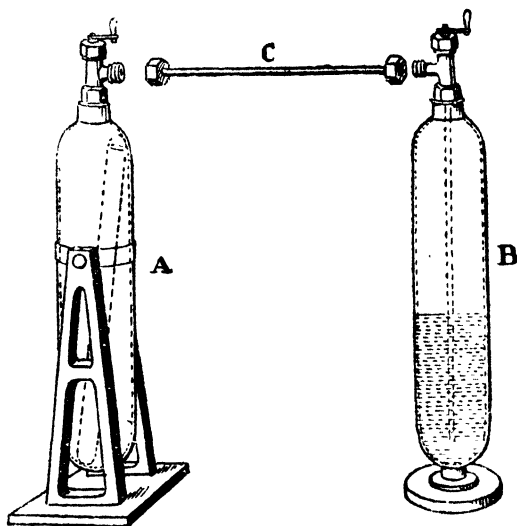

Fig. 205.

water, and a copper tube filled with sulphuric acid. An exactly similar vessel was prepared to receive the liquid carbon dioxide. The receiver having been surrounded by a bath of cold water, the gas was generated by tilting the retort A, and allowing the acid in the copper tube to mix with the sodium bicarbonate. The communicating tube, C, was then screwed into place, and the stopcocks opened, when the carbon dioxide distilled over, and condensed to the liquid state in the receiver, B. By allowing the liquid carbon dioxide to escape rapidly from a jet into a box of

non-conducting material Thilorier obtained solid carbon dioxide.

Using high pressures, and the low temperatures which could be produced by a bath of solid carbon dioxide mixed with ether, Faraday succeeded in condensing several more gases to the liquid state, but oxygen, nitrogen, hydrogen, and one or two other gases resisted all attempts at liquefaction until the year 1877, when MM. Pictet and Cailletet, working independently, announced the liquefaction of oxygen.

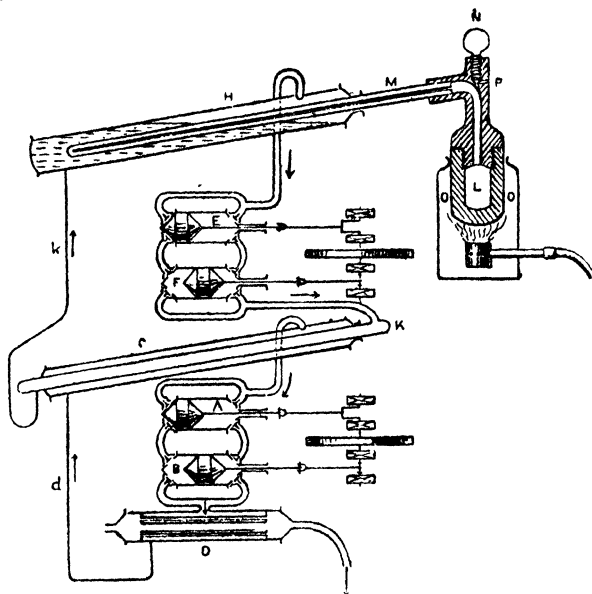

Fig. 206.

279. Pictet's and Cailletet's experiments. The apparatus of M. Pictet is shown in the accompanying figure. The oxygen was generated by heating potassium chlorate in the iron bottle, L (Fig. 206), which communicated with the closed tube, M. M was jacketed by a condenser, H, which contained liquid carbon dioxide boiling under reduced

pressure. By this means a temperature of about -140°C . was produced. As the carbon dioxide evaporated it was drawn off by the pumps, E and F, and compressed into the cylinder, K, which was surrounded by liquid sulphur dioxide. The carbon dioxide was condensed to the liquid state again, and returned to the condenser, H, by the

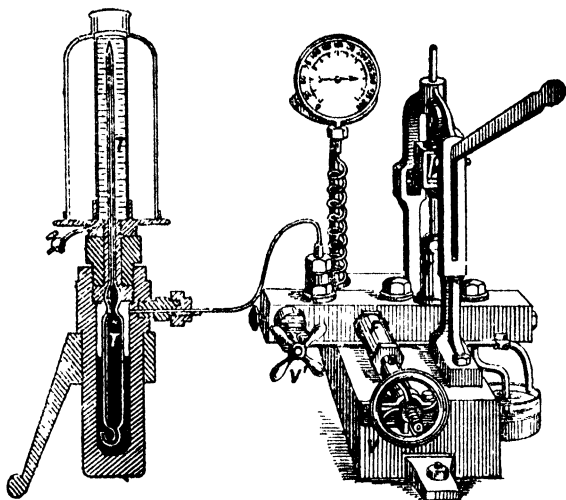

Fig. 207.

tube *k*. Similar pumps, A and B, drew off the liquid sulphur dioxide and condensed it in the receiver, D, which was surrounded by cold water. After the pumps had been working continuously for some hours, a pressure of about 300 atmospheres being produced inside M, the screw, N, was suddenly loosened, thus allowing the pressure to fall rapidly, and producing a still greater fall of temperature. It was then found that a small quantity of liquid oxygen had collected in M.

The apparatus of Cailletet was constructed on a different principle. The gas under examination was confined over mercury in the thick-walled tube, T (Fig. 207), the open end of which was placed in a reservoir of mercury. The surface

of the mercury was covered with water which communicated with the hydraulic pump, P. On working the pump the mercury was forced into the tube, T, and the gas was strongly compressed. The pressure was then suddenly diminished by unscrewing the screw, V', when the gas, now free to expand, forced the mercury back down the tube, T. Since the expansion takes place with great rapidity, the change is practically adiabatic, and the heat-equivalent of the work done in forcing back the mercury is absorbed from the gas itself. This absorption of heat causes such a depression of temperature that a portion of the gas liquefies, and collects in drops on the sides of the tube.

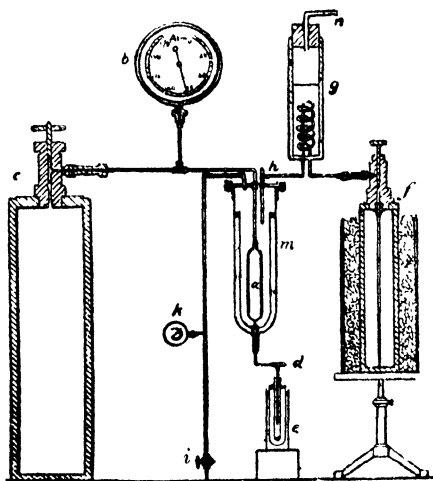

Fig. 208.

280. Wroblewski and Olszewski's experiments. By using liquid ethylene as a cooling agent, Wroblewski and Olszewski succeeded in obtaining liquid oxygen and liquid air in quantity. Olszewski's apparatus is shown in Fig. 208. Liquid ethylene stored in the flask, *f*, which is surrounded by a freezing mixture, passes through the spiral, *g*, which is immersed in a bath of solid carbon dioxide and ether, giving a temperature of about -100°C .

By opening the stopcock, *h*, the cooled ethylene is allowed to flow into the vessel, *m*, where it surrounds the small flask, *a*, of about 200 cubic centimetres capacity, which is destined to receive the liquid oxygen.

As soon as the liquid ethylene has completely covered the flask *a*, the stopcock *i*, which communicates with a large vacuum-pump, is opened, and, by working the pump, the ethylene in *m* is caused to boil under greatly reduced pressure. In this way the temperature of the ethylene falls continuously; when it has fallen below the critical temperature for oxygen, the stopcock which opens communication between the reservoir, *c*, wherein the gaseous oxygen is stored under pressure, and the small cylinder, *a*, is gradually opened. The oxygen passes over into *a*, and there under the influence of the high pressure and low temperature condenses to the liquid state and may be drawn off from time to time into the glass vessel *e*. By using liquid oxygen in place of ethylene as the cooling agent, Olszewski succeeded in liquefying hydrogen.

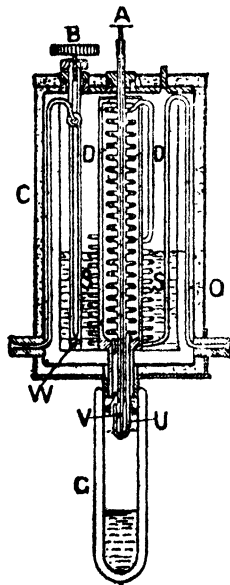

Fig. 209.

281. Dewar's experiments. The fact that a gas is strongly cooled by sudden expansion has been successfully utilised by Professor Dewar for the liquefaction of most of the so-called "permanent" gases. The gas to be experimented on is stored under high pressure in steel cylinders. It enters the liquefier (Fig. 209) by the aperture shown on the right hand side of the figure, passes up the tube, *O*, and round the spiral, *S*, which is cooled to a temperature of

-70°C . by immersion in a bath of solid carbon dioxide. The gas then passes down the inner spiral, *D*, into the tube, *U*, from which it escapes by a small jet. The escaping

gas, cooled by the sudden expansion, sweeps back in the direction shown by the arrows over the exterior of the spiral D, and cools the down-coming gas to a still lower temperature; this portion of gas escaping at the jet flows back and cools a further part of the down-coming gas yet more strongly, and this cumulative process of cooling goes on till the temperature of the gas falls below the critical point, when liquid begins to drip from the jet and may be collected in the vacuum vessel, G. By using liquid air, boiling rapidly under reduced pressure, as a preliminary cooling agent, in place of the solid carbon dioxide, Dewar succeeded in liquefying hydrogen.

282. Linde's and Hampson's method. A process for liquefying a gas without the use of any external refrigerating agent has been introduced, of recent years, by Herr Linde in Germany, and Dr. Hampson in England.

In general, when a gas at high pressure is forced through a fine hole, a diminution of temperature is produced. Experiments by Professors Joule and Thomson (Kelvin) showed that this fall of temperature is directly proportional to the difference of pressure on the two sides of the hole, and inversely proportional to the square of the absolute temperature. This cooling is the heat equivalent of the internal work done in forcing the molecules of the gas to a greater distance apart, and by using it in a cumulative manner somewhat after the method of Dewar as shown in the previous article the temperature of the gas may be lowered sufficiently to reduce it to the liquid state.

The apparatus employed by Dr. Hampson for the liquefaction of air is shown in Fig. 210. The air is drawn through the cylinder, A, which contains several trays of moist slaked lime to remove carbon dioxide and water vapour, and passes into the pump, B. Here its pressure is raised to about 16 atmospheres, and it passes through the copper coil, C, into a second pump, D, where the pressure is further increased to about 160 atmospheres. The pumps B and D, and the coils, C and E, are contained in tanks of cold water which serve to absorb the heat generated by the compression of the gas.

The compressed gas after passing through the cylinders, F and H, in which all traces of water vapour are removed, enters the Hampson liquefier. This consists of a series of concentric coils, filling the whole space K K, and terminating at their lower end in a jet, L, the opening of which is

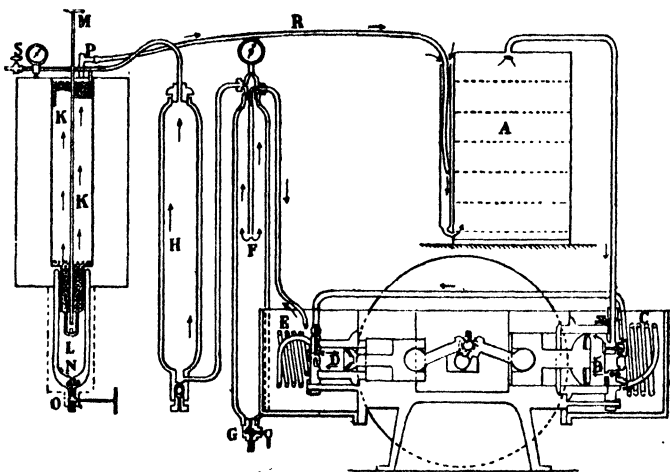

Fig. 210.

controlled by the screw and rod M. The gas, passing down inside the coils, escapes at the opening, L, and is cooled; the cooled gas then flows back over the coils, cooling them still further, and emerges at P, from which it flows through R to the air inlet in A. In this way the temperature of the gas emerging from the jet gets lower and lower, until the critical temperature is passed and liquid collects in the receiver N.

When hydrogen at ordinary temperatures is forced through a small hole it becomes hotter instead of colder, like the great majority of gases. The above method therefore could not be applied for the liquefaction of this gas starting from ordinary temperatures. Dewar, however, has shown that if the hydrogen is first cooled to -200°C .

it behaves like any other gas when forced through a fine hole, and has applied the discovery to the production of liquid hydrogen in quantity.

The last gas to be liquefied was Helium. This was accomplished by Prof. Onnes, of Leyden, in 1908. Gaseous helium at about -258°C . was allowed to expand from a pressure of 200 atmospheres to one of 40 atmospheres and a part of it liquefied. The boiling point of helium is -268.6°C . Its freezing point is below -270°C ., and therefore within 3°C . of the absolute zero.

ANSWERS.

EXERCISES II. (Page 30.)

2. $-6\frac{2}{3}^{\circ}$. 3. -40° . 4. $36^{\circ}, 68^{\circ}$.
5. F 1562, 21.2, -58 ; R 680, -4.8 , -40 .
6. C 110, $-2\frac{7}{9}$, $-23\frac{1}{3}$, -45 ; R 88, $-2\frac{2}{3}$, $-18\frac{2}{3}$, -36 .
7. C $187\frac{1}{2}$, -10 , $-33\frac{3}{4}$; F $279\frac{1}{2}$, 14, $-28\frac{3}{4}$.
9. -0.4°C. , -22°C. , -5°C.

EXERCISES III. (Page 36.)

1. $18.652 \pm .002$. 2. $.644 \pm .001$. 3. Limits of error $\pm .0002$.
4. 11.0. 5. 19 sq. cm.
6. 1.000089. 7. 1. 8. 1.0007; .999961. 9. .999975; 1.0013.
10. 1.00012; 1.00032. 11. 100.084; 99.984.
12. 2.00018, 8.00216.

EXERCISES IV. (Page 64.)

2. 1.0057 cub. dec. 4. 0.000016. 5. .03 cm.
7. .0000258, .0000086. 8. 1.0015 pt. 9. 10.15 gm.
10. 2.086 : 1.

EXERCISES V. (Page 92.)

2. 0.0000259. 3. 1.00029. 4. 0.000017.
5. 0.0001568. 6. 0.0000247. 7. 0.000518.
8. 0.000029.
9. $20^{\circ} - 40^{\circ}\text{C.}$.000307.
 $40^{\circ} - 60^{\circ}\text{C.}$.000458.
 $60^{\circ} - 80^{\circ}\text{C.}$.000596.
 $80^{\circ} - 95^{\circ}\text{C.}$.000698.
10. 100°C. 11. 0.000155. 12. .000281.
13. .000015. 14. 0.00091. 15. .000185.
17. 761.3 mm., 759.2 mm.

EXAMINATION QUESTIONS. (Page 198.)

1. .11. 2. 12 gm. 3. .064.
 6. (a) The liquid has the higher average specific heat in the ratio $\frac{18}{12}$ at the higher temperatures; (b) Yes, very likely.
 7. 25 gm. Less if allowed to stand before mixing.
 8. 0.247.
 9. The water is above 0° C., and is also in motion.
 11. 7.0 gm. 12. .5.
 13. 40 : 61. 14. $\frac{47}{52}$, or 0.904. 15. .089. 16. $\frac{1}{2}$.

EXERCISES X. (Page 223.)

3. 803 mm. 4. 742.4 mm. 5. 1117 c.c. 6. .0242 c.c.
 7 9.1. 8. 118.5. 9. 58.2.

EXERCISES XI. (Page 266.)

3. 506 mm.; 642000 dynes per sq. cm.
 5. Doubles from 99.93° C. to 99.96° C., and becomes infinitely large at 100° C., *i.e.* it would burst.
 6. 4 (approx.). 7. 537. 8. 65.3° C.
 9. 565. 10. 2020 calories. 11. 35.1° C. 12. 0.187.

EXERCISES XII. (Page 289.)

2. (a) The air is full of water vapour. The block of ice cools the air in its vicinity, and hence causes condensation; (b) the water is hotter than the air, and more evaporates than the air can sustain. Hence the "steaming."
 5. (1) Lowered more than with water. (2) Scarcely lowered at all.
 6. 84 %. 7. 52.9 %. 8. 0° C.
 9. 1.205 gm. 10. .017 gm.

EXAMINATION QUESTIONS. (Page 290.)

2. If the temperature is raised A reads the higher; if the temperature is lowered A reads the lower.
 5. 65.5 cm. 6. 76.23 cm.
 11. 3.15 gm. 12. .88 gm. 13. 77.6 gm.
 14. 53°. 15. $1\frac{1}{2}$ kilogrammes (approx.).
 19. 80.6 c.c.

EXERCISES XIII. (Page 321.)

- | | | |
|--------------------------------|------------------|-----------|
| 4. 5.2×10^7 calories. | 5. 1.525. | 6. .0384. |
| 7. 1.8×10^7 calories. | 8. 125 calories. | |
| 9. .00013 C.G.S. units. | 10. .067. | |

EXERCISES XIV. (Page 359.)

- The order is wood, rock-salt, tin; the wood is the hottest.
- 13%.
- 2.56%.
- 1000 gm.

EXAMINATION QUESTIONS. (Page 360.)

- 1.8 calories.
- 46 minutes.
- 5260 grammes.
- 1,800,000 gm.
- Rock glass transmits the long waves, glass does not.
- (a) The gilt bulb is the hotter.
(b) The clear glass bulb is the hotter.
- (1) Rise faster in blackened vessel.
(2) Cool faster in the blackened vessel.
- No, the vulcanite transmits infra-red waves.
- $\frac{1}{1024}$; No.

EXERCISES XV. (Page 376.)

- (a) 60 ft.-lb. (b) 7000 ft.-lb. (c) 120 ft.-poundals.
(d) 10^{11} gr. cm., or 10^6 kilogram-metres. (e) 6 ergs.
- (i) When at the end of the swing. (ii) When in the middle.
- The bow possesses potential energy due to strain or distortion.
- (1) 20,000 foot-poundals. (2) 8,000 poundals, 250 pds.-wt.
111,000,000 dynes.
- 3.75×10^9 dynes. 8. 52.1.
- 49.0 gm.-wt. per sq. cm. 10. £1 12s.

EXERCISES XVI. (Page 403.)

- The energy of the pumper.
- Part of the heat is due to the hot gases, the rest due to friction between bullet and barrel.
- Into heat.
- Mechanical energy is turned into heat energy.

5. During evaporation and the uplifting of clouds, heat energy becomes potential and kinetic energy. When the rain reaches the earth again all the potential energy and nearly all the kinetic energy has disappeared.
6. Chemical energy in coal \rightarrow Heat energy of flames and water \rightarrow Kinetic energy of train and passengers \rightarrow Kinetic energy of air and heat energy of rails and rubbing parts of the wheels.
7. By a specific heat process.
9. 5 water pd.-degrees C. 10. 1° C., 1.8° F.
11. 1390 ft.-pd. 12. 5.9 % 13. 165 pd.
14. 700 ft.-pd.; 2.09×10^7 ergs.
15. 112,000 ft.-pd.; 335×10^7 ergs.
752,000 ft.-pd.; 2250×10^7 ergs.
17. 2.87×10^7 ergs; 2.93×10^4 gm.-cm.
18. $s_p = .237$ $s_v = .168$. 19. One-thirteenth.
20. .53 ohm.

EXERCISES XVII. (Page 443.)

3. Iso-piestic = an equal-pressure curve. In an ordinary $p v$ diagram it would be a line parallel to the axis of volume, e.g. $b c$, Fig. 178.
Isometric = an equal-volume curve. It would be a line parallel to the axis of pressure. The line $c d$, Fig. 178, is practically an isometric.
The curve required may be plotted from the data of Art. 147.
4. 2005 mm.; 1520 mm. 5. 25.59 atmospheres; 425° C.

EXERCISES XVIII. (Page 458.)

3. 20.59° C.
4. $\frac{R_t}{R_o} = 1 + .003064 t - .000,000,51 t^2$
 $\delta = 1.65$.

EXAMINATION QUESTIONS. (Page 459.)

8. $\frac{1}{8}$. 9. 5.3 % 10. 38° C. (approx.).
11. 45.5° C. 12. $9\frac{11}{21}^{\circ}$ C.
13. 746. $\frac{\text{Cost of electrical energy}}{\text{Cost of coal energy}} = 38$, but only a very small part of the coal energy can be utilised.
15. 144, 285.5,

INDEX.

The numbers refer to pages.

ABSOLUTE TEMPERATURE, 119
 Absolute zero, 119
 Absorption, coefficient of, 341
 Acceleration, 362
 Adiabatic changes, formulae of, 438
 " curve, equation of, 430
 Adiabatics, 422
 Adiathermancy, 328
 Air thermometer, 22, 446
 Alcohol thermometer, 21
 Altitude, determination of, with the
 hypometer, 235
Amagat on deviations from Boyle's
 law, 418
Andrews' experiment on carbon
 dioxide, 409
 Anemometer, 288
 Anticyclones, 288
 Approximations, Ch. III., 32
 Atomic heats, 166

BALANCE WHEELS, COM-
 pensated, 60
 Barometer, correction for tempera-
 ture, 91
Beckmann, 189, 238
Beckmann's thermometer, 26
Berthelot on the latent heat of
 vaporisation, 256
Black's ice calorimeter, 190
 Boiling, 232
 " point, 15, 225
 " " , determination of, 237
 " " , of salt solutions, 238
Bottomley's experiment, 181
Boyle's Law, 96, 417

Breezes, land and sea, 135
Breguet's thermometer, 62
Bunsen on melting points, 181
Bunsen's ice calorimeter, 191

CAGNIARD DE LA TOUR'S
 experiments on the critical
 state, 413
Callendar and Barnes, 165
 " on the expansion of mer-
 cury, 85
Callendar's platinum thermometer,
 450
 Caloric, 143
 Calorie, 144
 Calorimeter, 146
 " , *Black's* ice, 190
 " , *Bunsen's* ice, 191
 " , *Joly's* steam, 261
 " , *Regnault's*, 153
 " , water equivalent of,
 147
 Calorimetry, Ch. VIII., 143
 Centigrade scale, 16
 Change, chemical, 8
 " of state, Chs. IX., XI.,
 171, 225
 " of volume accompanying
 change of state, 240
Charles' Law, 111
Clement and Desormes' experi-
 ment, 432
 Clinical thermometer, 25
 Cloud, 283
 " -forms, 284
 Condensation, 225, 246
 " and vaporisation, 224

Condenser, 226
 Conduction, 293
 „ of heat, Ch. XIII., 293
 Conductivity, determination of, 309,
 314
 „ , definition of thermal,
 301
 „ of gases, 319
 „ of liquids, 317
 „ , thermal, 293
 „ , thermometric, 303
 Convection, Ch. VII., 129, 293
 Cooling correction in calorimetry,
 157
 Couple, work done by a, 368
 Couples, 364
 Critical temperature, 213, 411
 Cryophorus, *Wollaston's*, 245
 Cyclones, 288

DALTON ON VAPOUR PRES- sure, 205

Dalton's Law, 111
 „ laws of vapours, 207
Daniell's hygrometer, 276
Davy lamp, 297
 „ on the dynamical theory of
 heat, 380
 Density and temperature, 63
De Saussure's hygroscope, 282
 Dew, formation of, 286
 Dew-point, 271
 „ hygrometers, 274
 Diathermancy, 328
 „ ; measurement of, 336
 Diffusivity, 303
 Dilatometer, the volume, 72
 Dilatometers, constant volume, 74
Dine's hygrometer, 275
 Distillation, 246
 Draught in a chimney, 132
Dulong and Petit on cooling, 345
Dulong and Petit on expansion of
 mercury, 77
Dulong and Petit's Law, 166
Dumas on vapour density, 217
 Dynamical theory of heat, 378

EBULLITION, 232

„ Ebullition, laws of, 230
 Effects of heat, 4
 Elasticity, 424

Elasticity, adiabatic, 425, 427
 „ , isothermal, 425
 Electrical pyrometry, 448
 „ , resistance thermometry,
 448
 Emission, coefficient of, 341
 Emissive powers, comparison of, 343
 Energy, 370
 „ , conservation of, 391
 „ , kinetic, 370
 „ , potential, 371
 „ , several forms of, 375
 „ , transference of, 374
 Entropy, 424
 Evaporation, 200, 241
 „ , cold caused by, 243
 Expansion, anomalies of, 55
 „ , coefficient of, 67
 „ , force of, 61
 „ , in freezing, 174
 „ , linear and cubical (or
 volume), 39
 „ , mean coefficient of, 46
 „ of water, 86
 „ , real and apparent, 66

FAHRENHEIT'S SCALE, 16

Fairbairn and Tate, 222
Faraday's experiment on regelation,
 180
Fery radiation thermometer, 458
 Fixed points of the thermometer, 14
 Fog, 285
Forbes' experiment, 310
 Force, 363
 „ , moments of, 364
 „ , units of, 363
Franklin's experiment, 227
 Freezing mixture, 186
 „ point, 14, 173
 „ „ of salt solutions, 187
 Frost, 288
 Fundamental interval, 16

GAS EQUATION, 124

„ Gas thermometer, 116, 430
 Gases, expansion of, Ch. VI., 95
 „ , liquefaction of, 247
 „ , radiation of, 354
Gay Lussac on the expansion of
 gases, 103
 „ „ on vapour density, 215

Gay Lussac on vapour pressure, 205
Gay Lussac's Law, 111
 Glazed frost, 288
Graham's mercurial pendulum, 59
Gravesande's ring and ball, 6
Griffiths, 165
 Gulf Stream, 137

HAIL, 285

Harrison's gridiron pendulum, 58

Haze, 285

Heat developed by a current in a wire, 397

„ „ general effects of, 5

„ „ of steam, total, 258

„ „ quantity of, 143

„ „ sensations, 1

„ „ unit of, 144

Heating by hot water pipes, 131

Hirn on the mechanical equivalent of heat, 396

Hoar-frost, 288

Hope's experiment, 89

Horse-power, 377

Humidity, relative, 269

Hydrometric method of measuring the expansion of liquids, 75

Hygrometer, 235

„ „ wet and dry bulb, 277

Hygrometers, dew-point, 274

Hygrometric state, 269

Hygrometry, Ch. XII., 268

Hygrosopes, 282

Hypsometer, 235

ICE CALORIMETERS, 189

Ice, density of, 190

Indicator diagram, 439, 441

Ingenhousz's experiment, 314

Invar, 60

Inverse squares, law of, 328

Isentropics, 424

Isometric, 123

Isopiestic, 123

Isothermal, 405

„ „ curve, 101

„ „ „ equation of, 102, 416, 430

Isothermals and Adiabatics, Ch. XVII., 405

„ „ for imperfect gas, 407

Isothermals for liquids and solids, 407

„ „ for perfect gas, 405

„ „ for vapours, 407

J, THE VALUE OF, 390

Jamin and Richards, 437

Joly's steam calorimeter, 261

Joule on the compression and expansion of gases, 390

„ „ on the mechanical equivalent of heat, 381

„ „ „ the, 367

Joule's equivalent, calculation from gases, 392

„ „ experiment on the maximum density of water, 90

„ „ Law, 397

KINETIC ENERGY, MOLECULAR, 4

LAND AND SEA BREEZES, 135

Laplace and Lavoisier on the expansion of metals, 52

Latent heat, nature of, 195

„ „ of fusion, 182

„ „ of fusion, determination of, 183

„ „ of steam, determination of, 253

„ „ of vaporisation, 251

„ „ of vaporisation, internal and external work of, 442

„ „ of vaporisation of steam, 252

Leslie's cube, 327

„ „ differential thermoscope, 126, 325

„ „ experiment, 244

Liebig's condenser, 226

Linear expansion, coefficient of, 40

„ „ „ measurement of coefficient of, 49

Liquefaction, 171

„ „ of gases, Ch. XIX., 461

„ „ „ *Cailletet's* experiments, 464

Liquefaction, *contd.*—

- „ of gases, *Dewar's* experiments, 466
 „ „ „ *Faraday's* experiments, 461
 „ „ „ *Hampson's* experiments, 467
 „ „ „ *Linde's* experiments, 467
 „ „ „ *Northmore's* experiments, 461
 „ „ „ *Onnes's* experiments, 469
 „ „ „ *Pictet's* experiments, 463
 „ „ „ *Thilorier's* experiments, 462
 „ „ „ *Wroblewski and Olszewski's* experiments, 465
 Liquids, expansion of, Ch. V., 65

MASON'S HYGROMETER, 277
 Mass, 362

Maximum and minimum thermometers, 23

Mechanical equivalent of heat, Ch. XVI., 378

Meldometer, 180

Melloni, 325, 326

„ on diathermancy, 337

Melting point, 172

„ „ „ determination of, 176

„ „ „ determination of, by cooling, 175

Mercury, expansion of, 77

„ thermometer, 12

Metallic thermometers, 62

Meteorology, 283

Miculescu, 396

Mist, 285

Molecular heat, 168

Momentum, 362

NATIONAL PHYSICAL LABORATORY, 19, 445

Newton's law of cooling, 340

OCEAN CURRENTS, 186

Optical methods of measuring temperature, 447

Optical pyrometer, 447

PAPIN'S DIGESTER, 234

Pendulums, compensated, 57

Perfect gas, 126

Permanent state, 299

Person, 194

Philips's maximum thermometer, 21

Power, 369

Pressure, 365

„ „ influence of on boiling point, 227

„ „ influence of on the melting point, 180

„ „ work done by, 368

Prevost's theory of exchange, 351

Puluj's apparatus of, 389

Pyrometry, 446

RADIANT HEAT, 323

„ „ „ absorption of, 345

„ „ „ diffusion of, 333

„ „ „ reflection of, 330

„ „ „ refraction of, 335

„ „ „ transmission of, 336

Radiation, 293, Ch. XIV., 322

„ „ „ absorption of, 345

„ „ „ nature of, 322

„ „ „ propagation and transmission of, 327

„ „ „ pyrometers, 448, 457

Rain, 283, 285

„ gauges, 285

Raoult, 189

Réaumur's scale, 16

Regelation, 180

Regnault on the expansion of gases, 105, 115

„ „ on expansion of mercury, 80

„ „ on deviations from Boyle's law, 417

„ „ on the latent heat of vaporisation, 258

„ „ on vapour pressure, 205, 230

Regnault's calorimeter, 153

„ „ experiments on specific heats of gases, 162

„ „ hygrometer, 274

Relative humidity, determination of, 269, 272
 Rime, 288
Ritchie's experiment, 356
Rowland, 164
 „ on the mechanical equivalent of heat, 394
Roy and Ramsden on the expansion of metals, 52
Rumford on the dynamical theory of heat, 379
Rutherford's maximum and minimum thermometers, 24

SALT SOLUTIONS, BOILING
 „ point of, 288
 Salt solutions, freezing point of, 187
Seeger cones, 446
 Selective absorption, 347
 Sensitive paper, 308
Siemens' pyrometer, 449
 Significant figures, 33
Six's maximum and minimum thermometer, 23
 Small quantities, arithmetical treatment of, 33
 Solidification, 171
 Solids, expansion of, Ch. IV., 38
 „ volume expansion of, 55
 Solution, 186
 Specific heat, Ch. VIII., 143, 152
 „ „ , determination of, 189
 „ „ , determination of, by cooling, 158
 „ „ of a liquid, 156
 „ „ „ solid, determination of, 151
 „ „ of gases at constant pressure, 161
 „ „ of gases at constant volume, 264
 „ „ of ice, 194
 „ „ of water, 167
 Specific heats, ratio of, 428, 432, 437, 439
 Spheroidal state, 248
 State, change of, 7
 Stationary state, 299
 Steam calorimeter, 260
Stefan's law, 345
 Sublimation, 249
 Sunshine recorders, 289
 Surface expansion, coefficients of, 40

TABLES :—

Aqueous vapour, pressure of, and mass of in air, 273
 Atonic heats, 167
 Boiling points of liquids, 238
 „ point of water at pressures near the atmospheric pressure, 236
 Coefficients of expansion of gases, 116
 Coefficients of expansion of liquids, 85
 Coefficients of linear expansion of solids, 54
 Conductivities, 320
 Critical temperatures, 414
 Density of water at various temperatures, 88
 Diathermancy of solids, 336
 Emissive powers of surfaces, 344
Glaisher's hygrometric factors, 278
 Latent heats of fusion, 185
 Latent heats of vaporisation, 269
 Maximum pressure of aqueous vapour, 236
 Melting points, 179
 Pressure of aqueous vapour, 207
 Reflecting powers of surfaces, 332
 Relative absorbing powers, 347
 Specific heats, 163
 Temperatures, some common or important, 29
 Volume expansion, coefficient of, 43
 Wet and dry bulb hygrometer, 279

Temperature, 2
 „ absolute, 119
 „ change of, 5
 „ critical, 213, 411
 „ degree of, 17
 „ difference of, 2
 „ gradient, 299
 „ measurement of, 9

Temperatures, some important, 29
 Theory of exchanges, *Prevost's*, 351
 Thermal capacity, 151
 Thermo-chrose, 347
 Thermo-dynamics, first law of, 400
 „ -electric currents, 401
 „ thermometers, 451

Thermometer, Ch. II., 9
 „ air, 22
 „ alcohol, 21

Thermometer, *Beckmann's*, 26
 " , clinical, 25
 " , construction of, 12
 " , graduation of, 16
 " , high temperature, 22
 " , mercury, 12
 " , metallic, 62
 " , sources of error of, 27
 " , weight, 69
 Thermometers, vapour pressure, 213
 " , very sensitive, 25
 Thermometry and pyrometry, Ch
 XVIII., 442
 Thermopile, 326
 Thermoscope, *Leslie's* differential,
 126
 Thickness, influence of, on diather-
 mancy, 339
 Trade winds, 135
 Transmission of radiation, coefficient
 of, 339
Tyndall, 355
 " on diathermancy, 338

UNSATURATED VAPOURS, 212

VACUUM VESSELS, 296
 Vander Waal's equation, 422
 Vaporisation, 200
 " and condensation, 224
 Vapour density, 214
 " , determination of,
 215
 " , methods of measuring
 temperature, 447
 " , of saturated vapour,
 222
 " jackets, 246
 " pressure, 200

Vapour pressure and temperature,
 202
 " " , maximum, 201
 " " , thermometers,
 213, 447
 " , properties of, Ch. X., 200
 Vapours, saturated and unsaturated,
 210, 211
 Velocity, 362
 " of sound, 431
 Ventilation, 132
Victor Meyer on vapour density, 219
 Viscous state during fusion, 175
 Volume, change at melting, 174, 175
 " " of, accompanying
 change of state,
 240

WATER EQUIVALENT, 147

 " , expansion of, 86
 " " , in freezing,
 174
 " , specific heat of, 164
 Watt, 202
 Weight, 363
 " , thermometer, 69
 Wet and dry bulb hygrometer, 277
 Wind, 288
 Winds, 135
 " , Trade, 135
Wollaston's cryophorus, 245
 Work, 365
 " done by a gas, 439
 " in an electric circuit, 373
 " , measure of, 366
 " , units of, 367

ZERO, ABSOLUTE, 119
 " change of, 27

