

UNIVERSAL
LIBRARY

OU_150816

UNIVERSAL
LIBRARY

611.88

23034

B52F

Bernstein

Five Senses of Man

OSMANIA UNIVERSITY LIBRARY

Call No. 611.88 Accession No. 23034

Author B.S.F. Bernstein

Title Five Senses of Man.

This book should be returned on or before the date last marked below.

THE
INTERNATIONAL SCIENTIFIC SERIES.
VOL. XXI.

THE
FIVE SENSES OF MAN

BY
JULIUS BERNSTEIN

O. Ö. PROFESSOR OF PHYSIOLOGY IN THE UNIVERSITY OF HALLE

'Man must persist in believing that the inconceivable is conceivable,
or he will never make a discoverer'—GOETHE

WITH NINETY-ONE WOODCUTS

EIGHTH EDITION

LONDON
KEGAN PAUL, TRENCH, TRÜBNER & CO. LTD.
DRYDEN HOUSE, GERRARD STREET, W.

1910

(The rights of ~~translation~~ and of reproduction are reserved.)

DEDICATED TO

HIS FATHER

A. BERNSTEIN

IN AFFECTIONATE LOVE AND GRATITUDE

BY

THE AUTHOR

P R E F A C E .



THIS BOOK lays no claim either to systematic completeness or to popularity understood in the widest sense of the word. It contains, of course, a general system, which has been elaborated in Treatises and Text-books in the course of time ; but this has been interrupted in many ways by physical and physiological explanations, which a proper treatment of the subject required, and it has therefore been found necessary to subject it to many changes in order to give it a popular appearance. So far the author has aimed at popularity : but he has endeavoured at times to take the reader a step beyond the domain of ordinary popular treatises ; and, if he has not succeeded in smoothing his path sufficiently, he entreats the reader's forbearance.

As an aid to the understanding of the subject, figures are given with the text, some of which were pre-

pared especially, the majority borrowed from scientific treatises, and considerably altered for the work. His acknowledgments are due to J. Müller, 'Atlas der Physik' (Leipzig 1871), from which most of the physical illustrations are taken; Kölliker, 'Handbuch der Gewebelehre des Menschen' (Leipzig 1867); Helmholtz, 'Handbuch der Lehre von den Geweben' (Leipzig 1871); Helmholtz, 'Handbuch der Physiologischen Optik' (Leipzig 1867); Helmholtz, 'Die Lehre von den Tonempfindungen' (Braunschweig 1872). The reader, who wishes to penetrate deeper into the part of science treated of, is referred to the above works.

THE AUTHOR.

HALLÉ & S. : *April, 1875.*

CONTENTS.



	PAGE
PREFACE	vi
INTRODUCTION	I



FIRST PART.

SENSE OF TOUCH.



CHAPTER I.

The Qualities of the Sense of Touch—The Sense of Touch and the Organs of Touch—The Sensitive Parts of the Skin	10
--------------------------------------------------------------------------------------------------------------------------	----

CHAPTER II.

Sensibility of the Sense of Touch—The Sensory Circles of the Skin—Relation of the Sense of Touch to the Activity of the Brain—Delusions of the Sense of Touch	24
-------------------------------------------------------------------------------------------------------------------------------------------------------------------------	----

CHAPTER III.

The Skin's Sense of Pressure—The Sense of Temperature	39
-----------------------------------------------------------------	----

SECOND PART.

SENSE OF SIGHT.

CHAPTER I.

	PAGE.
Formation of the Eye—Refraction of the Light-Rays in a Lens—Path of the Light-Rays in the Eye	48

CHAPTER II.

The Adjustment of the Eye—Short Sight and Long Sight	62
----------------------------------------------------------------	----

CHAPTER III.

Recognition of the Interior Portions of the Eye—The Ophthalmoscope	78
------------------------------------------------------------------------------	----

CHAPTER IV.

Formation of the Retina—The Blind Spot and the Yellow Spot—Position of the Perception of Vision in the Retina	89
-------------------------------------------------------------------------------------------------------------------------	----

CHAPTER V.

The Colours of the Spectrum—Combination of Colours—The Three Primary Colours—Colour-Blindness	100
---------------------------------------------------------------------------------------------------------	-----

CHAPTER VI.

Incidental Images—The Phantascope—Positive and Negative Incidental Images—Incidental Colours—Harmony of Colours	116
---------------------------------------------------------------------------------------------------------------------------	-----

CHAPTER VII.

	PAGE
The Movements of the Eyes—Binocular Vision—Simple and Double Vision—The Identical Spots of the Retina—The Horopter	123

CHAPTER VIII.

The perception of Solidity—The Stereoscope—The Telestereoscope—The Pseudoscope—The perception of Luminosity—The struggle between the Fields of Vision	137
-----------------------------------------------------------------------------------------------------------------------------------------------------------------	-----

CHAPTER IX.

Optical Illusions—Apparent Size of the Moon—Intuition—Illusions of the Sense of Colour—Mental and Corporeal Vision	150
------------------------------------------------------------------------------------------------------------------------------	-----

THIRD PART.

SENSE OF HEARING.

CHAPTER I.

General construction of the Organ of Hearing—Sound as a Tone, a Note, and a Noise—Musical Instruments	164
-----------------------------------------------------------------------------------------------------------------	-----

CHAPTER II.

Hearing through the Air and through the Skull—The External Ear and the Auditory Canal—Recognition of the Direction of Sound—Arrangements for the Protection of the Ear	177
----------------------------------------------------------------------------------------------------------------------------------------------------------------------------------	-----

CHAPTER III.

	PAGE
The Tympanic Membrane—The Tympanic Cavity, the Ear-Bones, and the Eustachian Tube—The Vibrations of the Tympanic Membrane and of the Ear-Bones	187

CHAPTER IV.

The Function of the Tympanic Membrane—The Telephon—Flame Manometer—The Importance of the Funnel-shaped Form of the Ear—The Muscles in the Tympanic Cavity	198
---------------------------------------------------------------------------------------------------------------------------------------------------------------------	-----

CHAPTER V.

The Labyrinth—The Organs of Corti—The Transmission of Sound in the Labyrinth—Presence of Sympathetic Vibratory Apparatus	210
------------------------------------------------------------------------------------------------------------------------------------	-----

CHAPTER VI.

The Sensation of Music—The Monochord—The Octave and its Divisions—Perception of Grave and Acute Tones—The Irritation of the Auditory Nerve	220
------------------------------------------------------------------------------------------------------------------------------------------------------	-----

CHAPTER VII.

Notes or Compound Tones—The production of Harmonics—The perception of the latter by means of Resonators—Graphical representation of Quality or Colour	245
-----------------------------------------------------------------------------------------------------------------------------------------------------------------	-----

CHAPTER VIII.

Analysis of Notes after the Law of Fourier—Helmholtz's Theory of the Perception of Notes—Formation of Notes by Electro-Magnetic Tuning-Forks	258
--------------------------------------------------------------------------------------------------------------------------------------------------------	-----

CHAPTER IX.

	PAGE
Harmony of Notes—Consonance and Dissonance—Production of Beats—Dissonance to be attributed to the existence of Beats—Influence of Harmonics upon Harmony—Resultant Tones—Chords—Noises.	269

FOURTH PART.

SMELL AND TASTE.

CHAPTER I.

The Sense of Smell	285
------------------------------	-----

CHAPTER II.

The Sense of Taste	295
------------------------------	-----

ILLUSTRATIONS.



FIG.	PAGE
1. Section of Skin of the Finger	17
2. Tactile Corpuscles	18
3. Theory of Stationary Sensory Circles	30
4. Theory of Moveable Sensory Circles	32
5. The number of unexcited Sensitive Fields necessary for producing a Double Sensation	33
6. Sensory Illusion	36
7. Horizontal Section of the Eye	50
8. The Formation of an Image by a Convex Lens	54
9. Camera Obscura	55
10. Reversal of the Retinal Image	57
11. Cause of Indistinct Retinal Images	63
12. Alteration in the Curvature of the Lens during Adjustment	65
13. Mode of observing Reflected Images in the Eye	68
14. Reflected Images observed in the Eye	69
15. Inversion of the Image upon the Retina	71
16. Action of Concave Lens on Convergent Rays	74
17. Irradiation	75
18. Irradiation	76
19. Irradiation	77
20. Production of a Shadow by the Blood-vessels of the Eye	82
21. Mode of examining the Interior of the Eye	84
22. The Ophthalmoscope	86
23. The Retina as seen with the Ophthalmoscope	87
24. Section of the Retina	90
25. Mode of proving the existence of the Blind Spot	92
26. The connection between the Nerve Fibres and the Rods and Cones	95

FIG.	PAGE
27. Formation of a Spectrum	101
28. Colours of the Spectrum	101
29. Colour Top	106
30. Method for Mixing Colours	107
31. Illustration of the action of the Spectral Colours upon the Retina	113
32. Phantoscope	118
33. Muscles of the Eye	124
34. Identical points of the Retina	131
35. Illustration of Theory of Single Vision	132
36. Illustration of Theory of Single Vision	133
37. Illustration of Theory of Single Vision	134
38. The Horopter	135
39. Stereoscopic Pictures	139
40. The Principle of the Stereoscope	139
41. The Principle of Brewster's Stereoscope	140
42. Stereoscopic Pictures	144
43. Stereoscopic Pictures	144
44. Principle of the Telestereoscope	146
45. Illustration of Luminosity	147
46. Optical Illusion	151
47. Optical Illusion	153
48. Optical Illusion	154
49. Optical Illusion	155
50. Optical Illusion	159
51. Optical Illusion	160
52. Optical Illusion	160
53. The essential parts of the Ear	165
54. Self-registering Tuning-fork	168
55. The Phonautograph	169
56. Simple Transverse Vibration	170
57. Organ-pipes	171
58. The Siren	172
59. Dove's Siren	173
60. Principle of Reed-pipes	174
61. Reed-pipe	175
62. Artificial Larynx	176
63. Sound-waves	178
64. Connection of Tympanic Membrane with Hammer-bone	188
65. Chain of Ear-bones	189
66. Mode of Vibration of Ear-bones	196

FIG.	PAGE
67. Telephon	200
68. Flame Manometer	202
69. Vibration of a Funnel-shaped Membrane.	203
70. The Labyrinth	211
71. Section of the Cochlea	212
72. The Crista Acustica	214
73. Section of Coil of the Cochlea	215
74. The Organ of Corti	215
75. Position of Fibres upon the Basilar Membrane.	216
76. Cell connected with the Fibres of Corti	217
77. Change of angle in the arch of the Fibres of Corti	218
78. Gradual increase in width of the arch of the Fibres of Corti . .	222
79. Monochord	233
80. Nodal Points	235
81. Siren	237
82. Savart's experiment for finding the Lowest Perceptible Tone .	239
83. Savart's experiment for finding the Highest Perceptible Tone .	241
84. Resonator	250
85. Production of a Pure Tone by means of Tuning-fork and Resonator	252
86. Analysis of Vibration into Fundamental Tone and 1st Harmonic	253
87. Complicated Form of Sound-wave	259
88. Displacement of the Phases of the Harmonic	264
89. Electro-magnetic Tuning-fork	266
90. Representation of the degree of Roughness between each Interval of the Octave	279
91. Olfactory Cells	287

THE
FIVE SENSES OF MAN.



INTRODUCTION.

IN the animal kingdom a number of organs have been developed which possess the property of making each organism acquainted with occurrences in the outer world, and which are therefore called the 'sensory organs.' They are found in their highest perfection in man, whose mental power surpasses in the same degree that of the rest of organised beings.

Every sensory organ may be shown to be anatomically connected with the nervous system by means of nerve-trunks and nerve-fibres. Touch, sight, hearing, smell, and taste are inconceivable without the presence of a nervous system, even if the sensory organs were in their present full development. An eye, of which the optic nerve has been destroyed, can present to us no picture of the outer world ; an ear, of which the auditory nerve has been severed, conducts no sound to us ; an arm, of which the nerve is injured, can feel nothing. Such an

eye may have all the appearance of a sound one, it may receive the rays of light and form an image of objects on its background, and nevertheless no sensation can be produced, for the connection with the brain, the centre of the nervous system, is wanting. The case is the same with the deaf ear, and with the arm devoid of feeling. The sensory organs are, therefore, only instruments of the mind, which has its seat in the brain, and by means of nerves makes use of these instruments to obtain information of external objects. The forces which operate in the outer world—namely, light, heat, sound, motion, and chemical affinity—produce in the sensory organs an irritation of the sensory nerves connected with them, and these convey the irritation which is there received throughout their entire length to the brain. Each organ of sense has its own specific irritation by which it is excited. The terminations of the optic nerve in the eye can only be excited by light-waves, not by sound-waves, and the latter can only excite the terminations of the auditory nerve in the ear. For the tactile nerves of the skin mechanical pressure and heat are specific excitements; for the nerves of taste and smell some chemical substance is necessary.

The *sensation* itself evidently first takes place in the brain. The *sensation of light* does not take place in the eye, where there is only an impression of light upon the expanded surface of the optic nerve; the sensation of light cannot, however, take place in the optic nerve itself, for it merely conveys the fact of the existence of the irritation to the brain. The *sensation of light*, a process to us most obscure, begins rather in the brain, which is

irritated by the excited nerve ; and since we can follow the optic nerve up to its origin in the brain, we therefore conclude that this process occurs in the central organ of the optic nerve.

The eye, therefore, is nothing more than an optical instrument which receives the light, and the optic nerve nothing more than an apparatus for conveying the intelligence of an irritation to the brain. It has been observed in operations that if the optic nerve is either torn, crushed, or even severed, at the moment when it is broken a strong flash of light is observed by the patient. This light is not real, for it is only perceived by the person under operation. The sensation of light arises merely from the mechanical irritation of the optic nerve, and from the extension of the irritation to the nerve-centre, where it awakens the process of the sensation of light, just as if the excitement had proceeded from the eye. In such cases the sensation of light occurs without any external objective light, and always takes place if the optic nerve is irritated in any way whatever by those influences which have an irritating effect on other nerves, such as electricity, heat, and chemical action. Objective light, that is to say, the light-waves of the ether, takes no part in this action ; it may therefore be accepted as a fact that in ordinary vision no trace of the light which enters the eye finds its way to the brain, but only a process of irritation peculiar to the nerve, and which can be produced in the nerve-trunk by pressure, electricity, heat, and chemical action, just as well as in the eye by light. In whatever way the irritation may have been caused, the process in the optic nerve is always the same, and the action on the nerve-centre always produces

the sensation of light. It must be exactly the same with the other sensory organs and their nerves. A sound does not extend beyond the end of the auditory nerve, and none of it is conveyed to the brain by the auditory nerve. The nerve, which is excited at its termination, communicates its condition to the brain, and causes in the centre of the auditory nerve the *sensation of sound*.

The sensation of sound, therefore, can take place without a sound-wave reaching the ear, if only the auditory nerve is in any way excited, whether it be by pressure, rupture, electricity, etc. Thus the irritation, which in the centre of the auditory nerve causes the sensation of sound, always takes place in the nerve.

It is clear that these ideas must be extended to the other sensory organs of taste, smell, and touch. All sensory nerves are only intended to communicate the fact of an excitement of the nerve from the terminations of the nerves to their centre in the brain—the *sensorium*. This irritation of the nerve is by no means similar to the first irritation. It is neither light nor sound, nor is it pressure nor warmth, nor a current of liquid which can be tasted, nor of a gas which can be smelt. It is rather a process of a peculiar kind, about which we may conclude that in all the nerves of the body the irritation is one and the same, since, in the muscular as well as in the sensory nerves, it exhibits the same phenomena and obeys the same laws.

The nerve, again, can no more appropriate a trace of the excitement than possess a trace of sensation. If we have at any place divided a sensitive nerve we can excite the divided part as strongly as we please ;

but all sensation is gone. The central nerve-trunk, however, is sensitive throughout.

Sensation can only take place in the sensorium. The excited condition of the sensorium is the material fact which corresponds to a sensation; and it is unnecessary that the sensory nerve concerned should have caused the irritation; for in dreams we have distinct sensations which are not caused by the specific excitement of the nerves, but only by the action of some internal excitement within the sensorium. Abnormal excitements also, which occur in the case of lunatics, or abnormal states of the blood in febrile diseases, cause subjective perceptions, which are called phantoms and hallucinations.

From these remarks it is clear that we really have no sensations of objects of the external world themselves, but only of the changes which occur in the sensorium.

How is it then that we, nevertheless, transfer our inward sensations to the outer world, that we consider as external to ourselves all that we see, hear, or feel? This fact, which to the healthy human mind seems so simple and natural, requires consideration.

The above question can be answered shortly, as follows:—From our very birth we learn by *experience* how to explain the sensations of our senses; and by a thousand experiments, which we make with eye, ear, and limbs in every-day life, arrive at the conclusion that the object of sensations, that is, their ultimate cause, is external to ourselves. The newly-born child, of course, experiences sensations. The light which enters its eye acts indisputably on its brain, for the

pupil contracts under the influence of the light, and this cannot occur without the co-operation of the centre of the optic nerve in the brain. The sensation is, however, only an internal one, like the feeling of satiety or of hunger; it is, of course, not yet recognised as proceeding from external objects. We observe, indeed, that a child gradually begins by moving eye and head to fix the object, namely, to bring the eye into such a position that the image of the object may fall upon the point of most distinct vision in the centre of the retina. Yet in this stage of development the transference of what is seen to the outer world has not yet taken place. The fixing of the eye upon objects does not take place suddenly, but is gradually developed from a spasmodic attempt to move the eye, which, perhaps, is caused by the irritative effect of the light; and if during this motion the point of distinct vision chances to fall upon an object which attracts attention by its brightness, colour, or motion, then by a repetition of this process, the child will gradually learn by experiment to repeat the required motion at will.

The use of the sense of touch is contemporaneous with the use of vision. The sensation of touch, also, is not recognised at first as proceeding from external objects, but is, perhaps, only perceived as an inward sensation, and as a check to movement. Now the hand—the most important organ of touch—is one of the objects which are seen at once; and since it has the property of great mobility in space, the eye will very soon see the hand moving and touching, and many sensations caused by it will be simultaneously perceived. When the hand touches an object, the

eye sees not only the object, but the hand itself also ; and when the hand is in motion we perceive simultaneously the inward sensation of movement of the muscles,—that is, the existence of the sensation of touch, and, by means of our sense of sight, the visible motion of the hand and the object.

The simultaneous occurrence of the sensations of touch and sight gradually leads to the impression that an object perceived by both senses is external to ourselves. To this step of knowledge there belongs, of course, a logical conclusion, the existence of which remains a problem of mental life, but which is carried out unconsciously, and certainly only formed by degrees. It consists in this, that if the two sensations of touch and sight always take place simultaneously, they must have one and the same cause, and, therefore, that the object which is seen and touched must be one and the same.

Still *one* such logical conclusion is not sufficient to enable us to recognise objects as external to ourselves. A second follows, which certainly may appear very scientific, but is not so, since it is formed unconsciously.

The two simultaneous sensations of touch and sight are two sensations of dissimilar quality, which have their nervous centres in different parts of the brain. If the cause of the sensations be found within the organs which perceive them, then it must be present at the same time in those of touch and sight, which are both different in constitution. That is to say, it must be a double one. However, according to the first logical conclusion, the cause is *single*, not *double* ; therefore it is not an *internal*, but an *external* cause.

The simultaneous action of the sensations of touch and sight is, in fact, for the human mind an important source of knowledge in the external world. Yet we must not on this account conclude that touch alone, without the assistance of sight, as in the case of persons born blind, cannot lead to knowledge. It is probable that the sense of touch alone might enable us to distinguish our own body and external objects sooner than vision. For the act of touching our body with our hand calls forth a *double* sensation of touch, one through the hand and the other through the part of the skin touched; touching an external object causes only a single sensation of touch through the tactile organ. Upon this physiological basis, an idea of the external world might be formed, although it would be difficult to analyse such a mental act so as to arrive at a simple logical conclusion.

If once the idea is formed that the object touched belongs to the external world, the education of the sense of sight will take place rapidly. The simultaneous and coincident sensations of sight and touch—the simultaneous perception of the motion by the eye, and the sensation of it by the hand—the commencement of the sensation of touch as soon as the eye sees that the object is moved by the hand, all lead to the conviction that the cause of both sensations must be one and the same, and that if the sensation of touch is recognised as external to ourselves, this must also be the case with the sensation of sight.

The sensations of the senses must be distinguished from other kinds of sensations to which the body is subject, which are termed *common sensations*. With them may be classed especially the sensation of pain, which is

spread almost over the entire body. The characteristic distinction between these common sensations and the sensations of the senses is, that by the latter we gain knowledge of the occurrences and objects which belong to the external world, and that we refer the sensations which they produce to external objects, whilst by the former we only feel conditions of our own body.

The limit between the sensations of touch and pain may be illustrated by the following example given by Ernst Heinrich Weber. If we place the edge of a sharp knife on the skin, we feel the edge by means of our sense of touch; we perceive a sensation, and refer it to the object which has caused it. But as soon as we cut the skin with the knife, we feel pain, a feeling which we no longer refer to the cutting knife, but which we feel within ourselves, and which communicates to us the fact of a change of condition in our own body. By the sensation of pain we are neither able to recognise the object which caused it, nor its nature.

The sensations of the senses, therefore, appear to be of a higher kind than the common sensations. The general sensibility of the body is, indeed, the general ground from which the sensations of the senses also spring; but they are distinguished from it by a more complete perfection, since they are produced by the action of the forces of the external world upon delicately constructed organs on the surface of the body, and the mind is thereby brought into immediate communication with the external world.

PART I.

THE SENSE OF TOUCH.

CHAPTER I.

The Qualities of the Sense of Touch—The Sense of Touch and the Organs of Touch—The Sensitive Parts of the Skin.

WE know from experience that every part of our skin possesses a certain sensibility, and that this sensibility varies in different parts. This property is given to the skin by a great number of nerves which originate in the brain and spinal cord, and extend in a tree-like form over the body. The sensibility of any part of the body is due to these nerves alone, for as soon as such a nerve is lost or diseased, the part of the body supplied by it becomes devoid of sensation.

We must, therefore, consider the skin as a sensory organ which encloses our entire body, and is adapted to render every part of the surface of our body sensible of external impressions, and, indeed, of impressions of manifold kinds, which arouse in us peculiar sensations, and are inseparably connected with mental processes. It is remarkable how various the perceptions are which we can

form by the aid of the skin alone, and there can be no doubt that if we had neither eyes nor ears, this organ of sense alone would be sufficient to enable us to construct an external world, which, however, would of course be limited in compass. For we could only include in our knowledge the objects which we could immediately reach, which we could bring into direct contact with our body, and which would betray their properties and nature by some kind of impression upon our skin, whilst a great part of the objects and occurrences in nature would remain a secret to us.

By handling a body we could learn its shape and form just as thoroughly as by the eye, especially when we remember that the attention of the mind would be concentrated in a greater degree upon the sensation of touch, as is really the case with the blind. We learn the size and dimensions of a body which we can touch, as soon as we can compare it with the size of our hands and our body; and our judgment is fully capable of determining the nature of its surface, whether it is smooth or rough, even or uneven. In short, the idea of the nature of bodies, in so far as they differ in form, which we could obtain by the use of the sense of touch alone, would be sufficient to give our life an incitement to activity. Our intelligence could even form matter for abstract thought, from these perceptions alone, and by this means arrive at the conception of a line, an angle, a triangle, etc., from which it would follow that mathematics is a science independent of the observations of sight, although in reality its origin has been derived from this source.

With the aid of the sensibility of the skin, moreover,

we could learn much more about the nature of objects than their mere form. With the aid of our organ of motion we can judge of the weight of a body, by estimating the amount of force which we have to use in order to lift it. At the same time every object exercises a pressure on the skin by its weight, which we perceive as such, and from which we can obtain an idea of its weight. Every other force, equally with weight, can act upon the skin by pressure, and thereby we are able to estimate the strength of the pressure which weighs upon the skin. A weight placed upon the hand, and a friendly pressure of the hand, differ but little from one another in their physical properties, however different their physiological action may be, and in both cases we measure by the pressure experienced the force which caused it.

These properties, however, by no means exhaust the power of discernment possessed by the skin; it possesses a property which is confined to it alone, and which cannot be replaced by any other organ of the body. Whilst we can estimate the form of a body much better by the eye than by the touch, and by the latter can only complete the knowledge obtained by the eye; further, whilst by the aid of our muscles we estimate a force which produces pressure, the perception of heat and cold remains as a peculiar property of the skin, and is shared by no other organ of the body. The eye, indeed, by the aid of certain signs, which it has gained by experience, is often able to tell whether a body is hot—when, for instance, it is glowing or steaming—but a perception of warmth is not possessed by the eye. This is possessed by the skin alone, and it is of great import-

ance to the maintenance of the organism that this property is spread over its entire surface ; for it surrounds it like a protecting wall against its worst enemy, cold, which, if not prevented, would destroy its existence. We are warned, however, of the approach of this enemy by a common sensation of the skin, an inward chill, which is only caused by a cooling of the skin, and which warns us against its approach. This peculiarity of the skin, however, also gives us warning of the approach of an excess of heat, which can do just as much harm to the body as the other extreme. The skin, therefore, possesses different *qualities* of sensations. Just as the eye, by the sensation of sight, can distinguish between the form of a body and its colour, so the sensitiveness of the skin by contact with an object can distinguish many of its properties, its form, its firmness, whether it is hard, soft, or liquid, and its temperature.

The peculiarity of the skin by which it recognises the form of an object, is called the *sense of touch* ; its peculiarity of estimating the force with which the object which it touches presses upon it, is called the *sense of pressure* ; the peculiarity of recognising heat or cold, the *sense of temperature*. From the combination of these three sensations is formed our faculty of discovering the properties of an object, to a certain extent, by touch alone. The tactile sense of the skin is divided into these three qualities, which are generally united in a simultaneous sensation. For a scientific investigation it is necessary to separate them artificially, just as white light is separated by the prism into its components, in order that they may be observed singly.

Besides these specific sensations, the skin is endowed

with common sensation, which is present also in the inner organs of the body, namely, the sensation of pain. It arises as soon as the excitement which produces sensation exceeds a certain strength, whether this be by means of pressure, heat or cold, or chemically by means of caustic substances. We cannot, however, consider pain as a sensation of the senses, since it gives us no knowledge of the nature of external objects. At most we can distinguish whether the pain felt by the skin is produced by a burn, or by the corrosion of acids, or by a sharp instrument; but this takes place only with the aid of the accompanying sensations of the senses—those, namely, of pressure, touch, and temperature. If we abstract it from the latter, then the sensation of pain has in all cases the same character, which makes itself apparent as soon as the cause of the irritation is gone, since the pain still remains. Excessive cold, when caused, for instance, by contact with frozen carbonic acid, produces the same pain as a burn.

By touch is understood in ordinary language a somewhat complicated process. In touching a body we employ the organs best adapted for the purpose, namely, the hands, the finger-tips of which are furnished with the most delicate sense of touch. This action, however, does not consist in merely feeling an object, but the motion of the hands plays a great part in it, since we allow the tactile organs to wander over the object which we are touching. This action, which we may call *active touch*, consists of a combination of motion and sensation, which brings different points of an object gradually into contact with the sensitive parts of the skin. Our imagination then collects together the points found,

forms from them lines and surfaces, and, in short, the entire figure of a body, the single parts of which are thus united to form a general picture.

In ordinary life the tactile senses only serve as an aid to the eye, which is the cause of our using it but little, and in the dark we often find of how little use it is in recognising objects. By practice, however, it may be brought to considerable perfection, as may be seen in the case of the blind, who are compelled to use it by necessity; and, further, in the delicate tactile sense of the tongue, which is accustomed to grope in the dark, and so extremely correct are the decisions it can make in the mouth, that it can recognise every little corner, angle, or tooth with the greatest exactness.

Much simpler than this action is the sensation and perception of contact with the skin. If, without making a movement ourselves, a second person touches with sufficient force any point of the skin with a pencil or a pin, we can recognise with closed eyes the part touched, with more or less certainty. In the hands this power is very perfect, and the more perfect the nearer we approach to the tips of the fingers. We can distinguish between touches on the three finger joints most correctly, and can determine the distance of the point touched from the finger-tip with tolerable certainty. Similarly, the sensibility of the face and of the forehead is strongly marked, while that of the lips and the tongue is more perfect still. Experience teaches us that there is no point of the skin's surface which is insensible to contact, when made with greater or less force. But the determination of the point touched is much less correct on the arms, legs, and the other parts of the skin, than on the hands and face.

The property of determining the point touched is called the skin's *sense of locality*, which is a factor of the tactile sense. The perception of contact is not sufficient to explain this phenomenon; the process consists much more in the localisation of the contact perceived. This power is an important psychical action, which evidently takes place in the brain, and can only be explained by the supposition, that in our imagination a picture, as it were, of our skin's surface exists, in which we seek for the position of the spot where contact has taken place, and which we find with greater or less certainty. The question, what is the relation between the skin's surface and the imaginative faculty, *i.e.* the brain, in which the faculty is situated, is sufficiently answered by the physiology of the nerves.

A great number of sensory nerves radiate from the brain and the spinal cord to the skin; they all consist of a very great number of fibres which separate from each other near the skin and here terminate in a peculiar manner.

The skin itself consists of three layers (fig. 1).¹ Upon the cellular tissue *d f* under the skin, which sometimes is very rich in fat, lies the first skin, the *dermis* (from *c* to *b*), which is of a tolerably compact texture, and by tanning is converted into leather. Its surface consists of a greater or less number of cylindrical or conical protuberances, *e*, which are called *papillæ*. Upon the dermis lies the *mucous layer*, *b*, which consists of a great number of small microscopic cells completely filling the depressions between the papillæ of the dermis. Lastly, the outer layer is the *cuticle* or *epidermis*, *a*, which forms

¹ Kolliker, 'Gewebelehrer.'

a compact firm skin, but consists of an intergrowth of cells which are filled with a solid horny substance. The blood-vessels and nerves extend only as far as the surface of the dermis, and to its papillæ; the mucous layer and the epidermis are completely free from blood and nerves. In the figure are seen also the *sweat-glands, g*, in the skin.

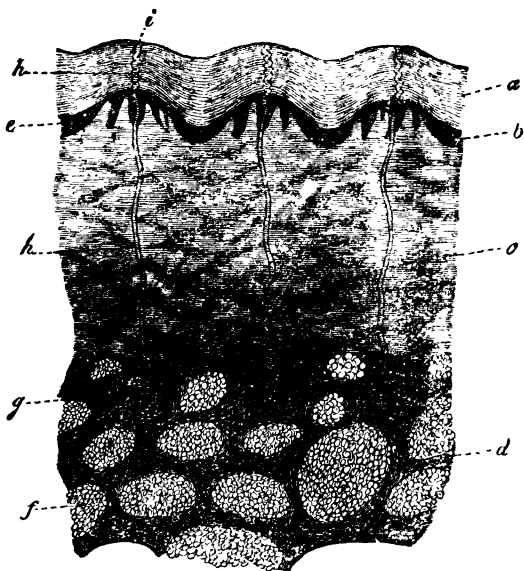

Fig. 1.

whose ducts, *h*, penetrate to the surface of the skin, *i*. The nerves of the skin which terminate in single fibres only extend to the dermis, and here they are observed to end in a peculiar manner in the papillæ. Many of them contain, for instance, an egg-shaped particle, *b* (fig. 2), which a nerve fibre, *c*, enters and in which it is lost after

several convolutions, *dd*, round it. They are called *tactile corpuscles*, and there can be no doubt that they act as

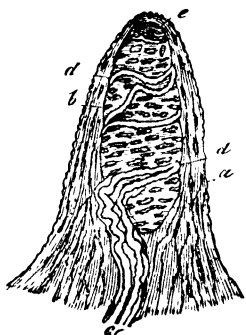

Fig. 2.

the instrument of the sensation of touch. They are not found in the same numbers in all parts of the skin, occurring in the greatest number in those parts where the sensibility is more acute, and more sparingly where it is weaker.

They are extraordinarily numerous at the tips of the fingers, where, in the space of a square line, about 100 may be counted, and they are tolerably numerous over the whole surface of the hand, but occur in much smaller numbers on the backs of the hands. On the palm of the hand also the papillæ, which, however, do not all contain a tactile corpuscle, occur in great numbers and are arranged in regular rows. This gives the peculiar striped appearance of the skin which is perceived on the surface of the hand. The nerves of the skin are observed to possess another terminal apparatus, similar to that of the tactile corpuscles, namely, long globules (pacinian bodies), in the hollows of which the nerve fibres terminate. In short, in the entire surface of the skin there exist terminal apparatus of a peculiar kind for the sensory nerves, and if we wish to follow the action of sensation further physiologically, we must start with the excitement of a nerve fibre which ends in a definite part of the skin, and follow the course of the excitement to the brain.

The course of the nerve between brain and skin along

which the excitement passes can be followed anatomically with a certain degree of exactness. A nervous fibre which ends in the skin forms as far as its union with the spinal cord or brain, a long, fine, continuous thread. The fibres which terminate in the skin very soon unite in small branches, and finally in thick nerve-trunks, before they enter the central organ of the nervous system, but in no case do two nervous fibres coalesce in these nerve-branches. We may, therefore, assume that every part of the skin is provided with isolated connections with the centre of the nervous system, which are united there just as telegraph lines unite at a terminus.

The physiology of the nerves, in which great advance has been made by the study of the action of motory nerves, throws light upon the course of nerve irritation, and leads to the result that the irritation of a fibre passes through its entire length without being communicated to the adjoining fibres. In a telegraph wire, of course, the electric current must by complete isolation be prevented from passing along any other wire, if the intelligence is to reach the station intended. The nerve-fibres on the contrary, in which we have to do with an action entirely different from, and much less rapid than electricity, do not require such isolation, and although they are closely packed together to the number of several thousand, yet they allow of no transfer of the irritation from one to the other.

When, by touching a part of the skin, we irritate the nerve which ends there, the irritation, insulated in the nerve, passes along it to its origin in the nervous centre. As soon as the irritation has arrived there, the action of sensation takes place; we know nothing of what this

consists, except that it can only take place in the nervous centre. This sensation is immediately connected with the consciousness that the irritation has been experienced by a certain definite part of the skin ; our imagination even places the entire action of sensation in the skin itself, although it cannot take place in the skin, but only in the brain. It is absolutely impossible for us to separate the sensation itself from the part irritated. In our imagination the locality of the irritation and that of the perception coincide exactly, and we are first taught by physiological experiments and the diseases of the nerves that this is, in reality, not the fact. The fact that the division of a nerve deprives a part of the body of sensation, shows us that the sensation itself cannot take place in the limbs, nor in the nerve itself, and that a nerve can only produce it when its connection with the brain and the spinal cord is intact.

The law is equally applicable to all sensory nerves, *that we refer the sensation which they produce to the organs at the terminations of the nerves, to the point where the cause of the irritation acts.* This is the case not only with the sensory nerves of the skin, but to a much greater extent with the optic nerve, the irritation of which takes place in the retina of the eye. The sensation of sight can only take place, however, in the brain, for it is lost as soon as the optic nerve is divided, and yet we transfer the object seen to the external world surrounding us. This fact, which is called *the law of eccentric sensation*, can only be explained by the assumption that our imaginative faculty is entirely formed by experience. We know from experience what our sensation is as soon as the contact with the skin has

taken place, and since we have convinced ourselves a thousand times, that this sensation is only caused by contact with the skin, since, further, we have no token that the excitement passes through a long nerve to the brain, therefore our imagination, in consequence of the experience gained, refers the entire action of the sensation to the spot where the recognizable cause of the irritation is present.

With the aid of these observations we can explain the sense of locality possessed by the skin, *i.e.* the power of determining correctly the locality of the irritation. From all parts of the skin run nerve-fibres, isolated like telegraph wires, to the nervous centre of the brain in which the consciousness of sensation takes place. The brain is, therefore, the terminus of these nerve-branches, and, as it were, receives and explains the messages transmitted to it. The brain, however, distinguishes very clearly by what branch such a message has come, and just as a clerk in a telegraph office, where a great number of wires meet from all sides, knows by experience from what direction each wire brings its message, so the brain also knows, by the experience it has gained, where an irritation has occurred, when it reaches it by a certain nerve-fibre, and therefore refers the whole sensation to that part of the skin where the irritation took place. It is probable that the brain, by its imaginative faculty, has formed a complete picture of the surface of the body, which has been obtained gradually and by experience, and is always being more highly perfected. The nerve-fibres are in a definite relative position to this picture, or rather with the part of the brain where this picture is formed, and we can imagine that every spot

upon the surface of our body is connected with its corresponding spot in the picture of the brain. When, therefore, an irritation is conveyed by a certain nerve-fibre, there arises in the brain a picture of the point of the skin where the irritation has taken place.

It is evident that if a true localisation of the sensation is to take place, all the connections of the skin with the brain must be in good order. If the irritation were to pass from one nerve-fibre to another the brain would no longer be able to distinguish the place from which it came, and could not localise the irritation.

A very interesting observation is often made in men, in whom, for the purpose of an operation, a piece of skin is removed from its original position and made to grow in another place. In order, for instance, to replace a nose, which has been destroyed by disease, or has been wanting from birth, surgeons detach a triangular piece of skin from the forehead, so that it is only attached by its apex to the root of the nose between the eyebrows; they then fold the piece over downwards, and sew it on the skin of the face in the position of the nose. The new nose after a short time grows on completely; if, however, it is pricked with a needle, the person does not feel the prick on the nose, but on the forehead—the original position of the skin. This sensation does not continue long after the operation, and the person gradually becomes conscious that the locality of the sensation is now a different one, and thus, by experience, learns to determine the locality correctly. A similar and no less interesting observation is made in the case of persons who have undergone amputation. They very frequently make the

remark that they have sensations in the amputated legs or arms, just as if the limbs were still existing. They feel in them the effects of frost and warmth ; they say they feel pain in this or that toe of the lost leg ; that they feel tickling, itching, etc., and distinguish the exact point where these feelings take place. The explanation of these facts is quite simple. In the stump of the amputated leg lie the divided nerve-trunks, which have provided the entire limb with sensory nerves. In the healed scar the nerve-stems are often irritated ; and since the irritation of the nerves is conveyed to the brain, it causes sensation, and simultaneously produces—we might almost say from habit—the picture of the same part of the body in which they naturally end. The brain, therefore, refers all these sensations, from the experience it has gained, to the same limbs in which the irritated nerves originate, even when the limb itself is wanting.

This very remarkable phenomenon is a manifest proof that the action of sensation takes place only in the nervous centre of the brain. Since even when a part of the body is wanting, the sensation of its existence and irritation does not disappear.

CHAPTER II.

Sensibility of the Sense of Touch—The Sensory Circles of the Skin—Relation of the Sense of Touch to the Activity of the Brain—Delusions of the Sense of Touch.

THE power of touch is not equally developed in all parts of the body. We know from experience that it is fully developed in the hands, since we use these organs for the purpose of touching objects. The hand, by means of its mobility and its articulated structure, is more especially adapted for this action than all the other parts of the body; and it is a general fact in the animal kingdom, that all organs adapted for touching are endowed with the greatest mobility, such as the feelers of an insect, the trunk of an elephant, and the tongue of all animals. Mobility alone, however, is not sufficient to give such organs the function of a tactile organ, but its surface must be especially provided with a fine sense of touch, in order to render it capable of perceiving fine distinctions of space.

Other parts of the body than the hand, especially the feet, are very little adapted for touching, not only on account of their inconvenient position and defective form, but because their skin possesses a far less cultivated sense of locality. It would, for instance, be very difficult to recognise with closed eyes the form of a

body, however simple, by the aid of the arm alone ; with the surface of the feet it could be done more easily, while with the hand we should very quickly make our decision. It seems extremely natural that the members most capable of motion should possess the finest sense of touch ; and it may with justice be said, that it is most probably developed by use, and, further, is transferred by inheritance. Apes, who use the feet for grasping just as much as the hands, have the sense of touch equally cultivated in both members, since both are used to the same extent for touching. In mankind, whose foot is transformed into an instrument of progression, the power of touch in this member returns to the hand ; but it is interesting to observe that occasionally in men, who are without arms, the sense of touch can be highly developed in the feet by practice, and as the mobility increases in an equal degree, they are able to write and execute many kinds of work.

The delicacy of the sense of touch, or, more exactly, the sense of locality in different parts of the skin, has been measured by Ernst Heinrich Weber, by a very ingenious method. It consists of the following highly interesting experiment, which everyone can perform with the greatest ease. Two persons are required for this experiment, one of whom tests the sense of touch of the other. For this purpose a pair of compasses are taken, whose points, somewhat blunted, are placed at a certain distance from one another on a part of the skin of the other person. The latter must then say, with closed eyes, whether he feels the contact of two separate points, or whether both points seem to be merged into one.

The result of this experiment upon the less sensitive parts of the skin is very surprising. If, for instance, the points are placed on the forearm in the direction of the length of the arm, at a distance of about four centimetres (1·58 inch) apart, the sensation is then evidently a double one; but as soon as the distance between the points is less than three centimetres (1·18 inch), the contact is then felt as that of a single point—that is to say, both contacts are united into a single sensation, and the person on whom the experiment is made feels considerable surprise when, on opening his eyes, he sees that, contrary to his sensation, two points of the skin have been touched at such a considerable distance from each other.

We may now discover by experiment for each part of the skin, how near the points may be brought together without the impression produced being that of a single point, and the smaller the distance the finer is the sense of locality for that part of the skin. By this test the tip of the tongue is found to be the most sensitive, for the two points are distinguished when at a distance of only a millimetre apart (·0394 inch). Then come the tips of the fingers, which can distinguish a distance of two millimetres (·079 inch). In the hand the sense of locality varies with the joints of the hand; it is considerably finer on the palm of the hand than on the back, which cannot distinguish a distance of four or five millimetres (·157–·196 inch) between the points of the compasses.

In the face, the lips possess a tolerably fine sense of locality. If the points of the compasses are placed on the cheek near the ear, so that both can be clearly distinguished, and then brought slowly over the skin

to the lips, a sensation is experienced as though the points were being separated from one another. The sense of locality increases, therefore, as we approach the mouth; and while the distinction between the two points becomes more clear, it seems as if they were being separated also. The sensation is precisely similar if the points are placed across the forearm, and slowly moved towards the hands as far as the tips of the fingers. Here also we imagine that the lines drawn by the points, although really parallel, are always diverging, since the sense of locality increases as we approach the fingers.

The skin of the back has the dullest sense of touch, since when the points are at a distance of five to six centimetres apart (1·97–2·36 inches), they are still perceived as a single touch. It is quite astonishing how greatly the distance between the two points must be increased on the back before we are clearly conscious of a double impression. In the arms and legs the tactile sense increases with the distance from the trunk, agreeing with the corresponding mobility of these parts; and the sensibility, again, is greater on the inner or bent side than on the outer or extended side. If, now, for any part of the skin we measure exactly the distance between the two points, at which the sensation of the two points passes into that of a single one, and make this measure in many directions, we obtain for the part of the skin under examination a figure of a circular form, within which the simultaneous contact of any two points is felt as that of a single one. In many parts of the skin, on the arm, for instance, this figure has an oval shape, since the power of distinguishing two points is more per-

fect in a transverse than in a longitudinal direction. Such a figure, which has more or less of a circular shape, is called the sensory circle of the skin; and by exact measurement the skin of the whole body has been divided into a number of *sensory circles*, which differ extremely in size, and considerably in form.

An interesting observation is explained by the existence of such sensory circles. If a metallic tube, with triangular, circular, or rectangular sides, is pressed on the skin, it is not easy to recognise the form of the tube. The smaller the sensory circle, the easier this is, and the smaller the diameter of the tube may be. Upon the insensible parts of the skin, however, the sensation is always the same, whatever the form of the tube may be, as long as its size does not greatly surpass the diameter of a sensory circle. For when all the points of the sides lie within a single sensory circle, then they all unite to a single point. Upon the arm, therefore, we cannot distinguish between a triangular, circular, or rectangular tube of two centimetres ($\frac{1}{2}$ inch) diameter, while this can easily be done upon the palm of the hand.

Figures more complicated than the above are, of course, still more difficult to recognise. This is well seen from the ease with which letters, or even words of moderate size, are understood when written with a pencil on the palm of the hand, while it becomes difficult to do so, if they are written on the arm, and the letters must be of a very large size to be understood if written on the back. Moreover, in this case the recognition is easier than when a figure already made is placed upon the skin, since there is time to devote the attention to

each single point of the figure. In any case, a letter must extend over several sensory circles in order to be understood.

In order to obtain an insight into the facts mentioned above, we must return to the anatomical relation between the skin and the nervous centre in the brain. We know that all parts of the skin are provided with separate nerve-fibres, in which the irritation is isolated, and by which it is communicated; and we have supposed that the brain has learnt from experience, to what part of the skin the nerve-fibre belongs, which has brought intelligence from without. We have said, in order to render the representation more exact, that every nerve-fibre in the brain is provided with means of recognising the part of the skin in which the nerve ends. Still these words explain nothing further, and it is better to rest with this conclusion, that the property of the brain to recognise the locality of the irritation of the nerve-fibre is a power which has been gained by practice.

However, the observation has been made, that this property of the brain has its limits, since in every part of the skin two points at a certain distance apart produce a single, not a double impression, and in certain parts of the skin this distance may be very considerable. All the points which lie within a sensory circle cannot be distinguished from each other by the brain, and all the irritations, which are communicated in the brain from these points, are united by the imagination into a single irritation.

The explanation of these phenomena, which would most naturally occur to us, consists in the assumption that an entire sensory circle is always provided with a

single nerve-fibre. We can imagine that the terminal expansion of a fibre is extended over the space of each single sensory circle, and that the terminal apparatus of the fibres varies in size according to the size of these circles.

There are, however, important reasons against such an assumption. It has, in fact, been observed that in the skin the nerve-fibres are considerably divided; but since in the parts of the skin of low sensibility the sensory circle has a diameter of 6 centimetres (2·36 inches), it would, therefore, follow that a single nerve-fibre would extend over a similar space. This is,

however, improbable, since although in a large sensory circle, there is no power of distinguishing points situated at a considerable distance, yet there is no single point in this circle which is not sensitive; and if a large sensory circle only receives a single fibre from the brain, then this must be split up into an inconceivable number of fibres, in order to supply the whole circle.

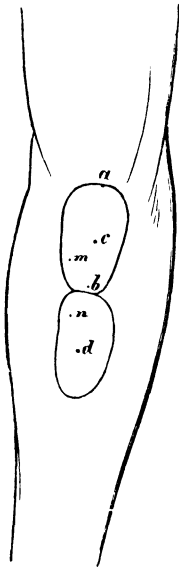

Fig. 3.

Moreover, the following phenomena are against this supposition. Let (fig. 3) the sensitive regions 1 and 2, which touch each other, be measured on the arm round the centres *c* and *d*. Now, if the circle 1 is provided with a fibre 1, and the circle 2 with a fibre 2, it is easily seen that at the points *a* and *b*, which lie within the circle 1,

the sensation would be a single one, since the same nerve-fibre would be excited. Contact, however, with

the centres c and d , which are situated at the same distance apart as a and b , according to this assumption, will not produce a single, but a double impression, since they belong to different nerve-fibres. There are two points even still nearer, m and n , where the impression will appear double, since they also lie within the terminal limits of two fibres. It is, however, quite the contrary. Contact with the points c and d produces in this case a single impression, and much more so with the points m and n . We see, therefore, that the terminal limit of a single nerve-fibre cannot possibly have the same size as an entire sensory circle. If it were so, the circle must have distinct limits, within which the phenomena must obtain, as shown above. If we move the points of the compasses forward from the sensory circle 1 to the circle 2, then the perception of a single impression must suddenly pass into the perception of a double one, as soon as the points of the compass overstep the limit; and since this is not the case, it therefore follows that, in this sense, such definite limits do not exist in the skin.

The best explanation of all the facts hitherto mentioned is given by Ernst Heinrich Weber, an investigator who has done good service in this, as well as in other branches of physiology. He assumes that the terminal limits of a nerve-fibre are much smaller than the sensory circles as found by measurement, so that the latter always contain a great number of isolated nerve-fibres. If, now, two terminal limits are excited, and if a certain number of isolated fibres which are not excited lie between them, then the impression is only a single one. These unaffected terminal limits which lie between

the irritated points, and whose fibres are not irritated simultaneously, make the brain conscious that the skin is touched in two separate points, and at the same time the number of unexcited fibres gives the brain a measurement, by means of which it can estimate the distance between the points touched.

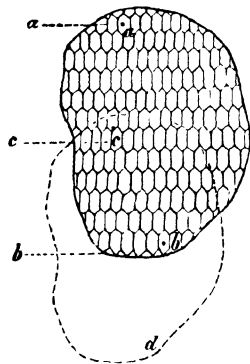

Fig. 4.

In fig. 4 the small hexagonal figures represent the terminal boundaries of the nerve-fibres. Let us assume that twelve intermediate figures are necessary to enable us to perceive a double impression. Therefore *a* and *b* will lie upon the limits of a single sensation. Similarly with *c* and *d*, which have the same

number of intermediate terminal boundaries. We now see why the sensation of a single contact is not suddenly changed into that of a double one, on moving the points of the compasses; for as long as less than twelve terminal limits lie between the points, we still perceive a single contact. This idea makes it clear that a sensory circle can have no fixed boundary on the skin, but that we may imagine it removed at will, as is represented by the dotted line fig. 4, as long as it includes the definite number of terminal boundaries of the nerve-fibres.

The division, therefore, of the skin by the terminations of the nerve-fibres is like a mosaic, each termination having its separate little piece of mosaic, which we may call the sensitive field of this nerve. Contact with

a sensitive field excites in our brain the idea of a certain definite part of the skin; but if two neighbouring sensitive fields are touched, we do not feel two separate points, since we have no sign to separate them by. We shall see clearly that this must be so, if we place on the skin some straight edge, the sharp edge of a plate, for instance, and consider the sensation it excites more closely. Our immediate sensation tells us, that, commensurate with our experience, a straight line has touched us. This line divides (fig. 5) a certain number of sensitive fields in each of which a single nerve-fibre is excited. If, now, in the approximate sensory circles 1 and 2, 2 and 3, etc., our sensation is that of separate points; if we can separate the locality of the point 1 from that of point 2, then the entire line must appear to consist of points. Since, however, the sensation is not that of broken contact, it follows that we cannot separate locally two sensitive fields from each other. A separation of locality is much more probable, if between the two excited sensitive fields, one at least is not excited, since it is only this unexcited sensitive field which makes us conscious of two excitements whose localities are different.



Fig. 5.

A single unexcited sensitive field between two excited ones is not sufficient to enable us to perceive a double impression. The phenomena of the sense of touch are explained in a much less forced manner, as soon as we assume with Ernst Heinrich Weber that a greater number of sensitive fields must intervene between the excited fields, before we can perceive a double impression.

All the *sensations of the senses* then, of which we are capable, pass into *perceptions of the senses*, as soon as certain mental operations have been aroused by the sensory excitement.

The observation may very frequently be made that, under certain conditions, we are not conscious of impressions, although they may have undoubtedly acted on our sensory nerves in no inconsiderable degree. If, for instance, one person is engaged in an animated conversation with another, and we meanwhile lay our hand upon the shoulder of the former, it frequently happens that this contact, though readily noticeable, is not felt, or rather that it does not have the desired effect. We are then accustomed to say that the conversation claims so much of his attention that he is unable to receive other impressions; or, more simply, 'that he is too much absorbed in conversation.'

This expression is grounded on views which are quite correct, and in accordance with physiology. The impression made on the shoulder had doubtless in this case excited the nerves of the skin, and they had undoubtedly conveyed the irritation to the spinal cord and the brain, and aroused there the action of sensation. But at this moment, the brain was unable to become conscious of the irritation which reached it and the sensations which they cause, and thereby to produce a perception; because, although the brain was at this moment in full activity, the organs of consciousness and the will were entirely occupied in awakening and forming ideas, and transforming them into intelligible language by the aid of the motory and muscular nerves. It was evidently this latter process in the brain, which prevented it from

becoming conscious of the sensations which acted on it, so that it annihilated the irritation which reached the brain and prevented its producing perception.

These examples are only introduced here in order to show how closely sensory impressions are connected with mental action, both of which take place in the brain. The conclusions which we formed concerning the sense of touch must be extended to the other senses also ; but it is the many interesting experiments made on the sense of touch which force us to conclude that no sensation is ever produced by the sensory organs alone, but always in the brain, where all sensory nerves originate.

Some very remarkable observations which have been made in experiments upon the sensory circles are satisfactorily explained by these conclusions. Upon the same spot of skin the size of a sensory circle not only differs in different people, but varies considerably in the same person at different times. The most interesting fact, however, is, that constant practice considerably diminishes the limit within which a single impression is produced in certain parts of the skin, in those parts, for instance, which are not naturally very sensitive and where the sensory circles are large. If, however, this practice ceases, the delicacy of the sense of touch will decrease also. It is also interesting to observe that the blind, who are compelled to replace the power of vision by the sense of touch, have much smaller sensory circles than other people, and we can hardly doubt that this is due to practice.

Such facts give an evident proof that the property of the skin of measuring the distance between two points is really a property of the brain. By practice the brain

learns to distinguish two approximate points on the skin, since it has become conscious of the fact that, between these two excited points, a number of points are situated which are not excited. The greater this number, the more distinctly can we recognise the existence of the points ; but there is a number which is not sufficiently great to enable us to recognise the points. By practice, however, this number can be diminished ; that is to say, fewer non-excited points between those which are excited will then be necessary to create the impression of a double sensation. Since, during this process in the skin the arrangement of the nervous system has remained the same, practice being nothing more than the act of learning, it must therefore clearly follow, that we have here to

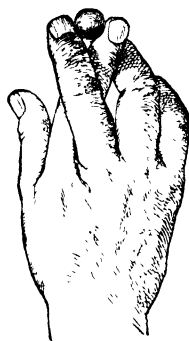

Fig. 6.

do with a process of the brain, and that the sensory circle of the skin is not really situated in the skin but in the brain.

A very interesting illusion of the sense of touch, which is probably already known to the reader as a trick, is no less a proof of the views just given. It is an experiment which even Aristotle regarded psychologically. If we cross the first and middle fingers and then pick up a pea from the table, we have a distinct impression that we are holding two peas, and even when we look closely and convince ourselves that there is only one pea, we can hardly get rid of the impression. The illusion is, moreover, particularly strong if we roll the pea backwards and forwards between the fingers.

The reason of this curious illusion is evidently that the tactile surfaces of the skin are placed in an unaccustomed position. If we were to hold the pea with the first and second fingers in their usual position we should know by experience that there was only one pea. If, however, we cross the fingers our experience not only leaves us in the lurch, but deceives us in the impression produced by the sensation.

The cause of the illusion proceeds in reality from the experience of the brain which has been inculcated by practice, and in such a case has led us into error. Thus when we cross the fingers we bring the outer side of each finger into contact with the pea simultaneously. But these two sides of the fingers are, in the ordinary position of the hand, invariably turned away from each other, and, if when in this position, the two sides are touched simultaneously, the brain knows by experience that it can only be caused by two different objects.

Now this experience of the brain is not affected by a change of circumstances, but remains unaltered in whatever position we place the fingers. If we cross them, and hold between them a small ball, their position will still be the natural one, as far as concerns the sense of touch which the brain has gained by experience, and therefore, our imagination changes the crossed position into the ordinary one. When this takes place our imagination must also convert one ball into two.

This shows us how firmly the representation of the surface of our body is imprinted upon our brain. The brain knows perfectly well the natural position of every part of the body, and the situation of every point of skin, a knowledge which it has gained by many years of prac-

tice and experience. It is also able to recognise a great number of the movements of different parts of our body. When the hand is moved over any object, it is placed in many different positions with regard to the body, and by the touch we obtain a true representation of the object, whilst, by experience, we can tell the position of the hand at the same time. We can however only recognise all these positions and movements of our tactual limbs correctly after sufficient practice and experience. But as soon as we bring our limbs into an unaccustomed position, our power of recognising correctly tactual impression ceases, and we are no longer able to estimate rightly the position of the objects touched.

CHAPTER III.

The Skin's Sense of Pressure—The Sense of Temperature.

THE skin not only possesses the faculty of perceiving contact with a body, but it is also able to calculate the pressure with which the contact takes place.

If we lay an object upon the outstretched hand, we are able to determine the weight of it by raising and lowering the hand, till we are sufficiently satisfied as to the amount of the weight.

Our decision is founded principally upon the amount of exertion, which the muscles of the arm are obliged to use in lifting the weight ; and as we have a distinct sensation of the activity of these muscles, and as this sensation increases with an increase of action in the muscles, we are thus able to determine the difference between different weights. But in such an experiment the weight laid upon the hand acts not only by the tension of the muscles, which are trying to support it, but it also makes an impression upon the skin, which we feel as well as the tension of the muscles. We have to do, therefore, with two influences which almost invariably work together when we lift an object, but which in a scientific examination of the question must be considered

independently. Let us lift, for example, a weight with a ring attached to it, from the ground with the arms straightened at the side, then the weight acts by pressure upon that part of the skin of the hand which grasps the ring, and, by tension, upon the muscles used in lifting. The tension upon the muscles remains the same with the same weight, but the influence of the pressure upon the hand may differ with the form of the handle by which the weight is held. If the handle consists of a broad ring, then the pressure of the weight will be spread over a large portion of the surface of the hand, and each point of the skin will only experience a very moderate amount of pressure ; if, however, we take a very small ring, then the whole pressure is concentrated upon a small surface of skin, and we then experience much more pressure, which may even become painful.

Our decision upon the weight of a body is then guided by these two sensations which work simultaneously, and; therefore, in science we distinguish two separate properties which correspond to these sensations. We designate the property of realizing the amount of muscular action the *muscular sense*, and the property which estimates the amount of pressure upon the skin, the skin's *sense of pressure*.

In ordinary life the muscular sense and the sense of pressure almost always act simultaneously whenever we lift an object, and, therefore, through the influence of the sense of pressure we are frequently subject to illusions when estimating the weight of objects. For if we lift a heavy body when a very small portion of it presses upon our skin, it will generally appear heavier than if it pressed upon a larger surface, because the pressure on

the skin is greater. In such a case we are at least very liable to make an incorrect estimation of the weight of an object. But if, by other means, we are able to estimate its weight correctly, then we should say that the body was not nearly so heavy as it appeared to be from the pressure it exercised, but that it was only very inconvenient to carry.

But we calculate the weight of a body chiefly with the help of the muscular sense, and the pressure is only an accompanying sensation, which exercises a smaller influence upon our decision. This is proved by some very interesting experiments made by Ernst Heinrich Weber, which we will follow. He wished to show the smallest difference of weight which could be felt when the weight was lifted by the hand, and he found that $19\frac{1}{2}$ oz. could generally be distinguished from 20, but not $19\frac{3}{4}$ from 20. This ratio of $19\frac{1}{2}$ to 20 remained nearly constant for all weights, *i.e.* $9\frac{3}{4}$ could be distinguished from 10, or 39 from 40.

In these experiments muscular sense and the sense of pressure are combined, and both influence the decision. But other experiments may be mentioned in which the sense of pressure alone operates, the muscular sense being quite excluded.

If we lay the open hand upon the table, and put a weight upon it, we are even then able to determine the weight by its pressure, without making any muscular exertion at all. We can also distinguish in this manner between different weights, but it has been proved that our judgment is then not nearly so accurate as when we lift an object. We are not then able to distinguish $19\frac{1}{2}$ oz. from 20, but at the most $14\frac{1}{2}$ from 15.

Nature has, then, provided us with two powers which we can use together as balances to determine the weight of a body. The one which we call the muscular sense is the more sensitive balance, whilst the other, the sense of pressure, is much less so. In reality, we use both these means simultaneously in determining the weight of an object.

Many interesting discoveries have been made by these experiments upon the sense of pressure. If we wish to discover what two weights we can distinguish from each other by pressure, we should best effect it by placing both weights quickly one after the other upon the same part of the skin, for example, upon a finger stretched out on the table. It would be much more difficult for us to decide if we laid both weights simultaneously upon two different fingers, since we could not turn our attention at the same time upon two different parts of our skin. But even when we choose the same place on the skin, our decision depends on the time which elapses between the two trials. Weber remarked that, with the greatest attention, he could distinguish $14\frac{1}{2}$ oz. from 15, if more than 10 seconds had not elapsed between the deposition of the two weights. If the time is longer, the answers begin to be uncertain, and we can then only distinguish those weights from each other whose ratio is greater. After the lapse of half a minute for example, Weber could only distinguish 2 from $2\frac{1}{2}$ or 12 from 15.

These experiments have a particular interest, because in them an intellectual force, which we generally designate under the name of *memory*, accompanies the sensory perception. For the sense of pressure ceases as soon as

the pressure is removed ; our brain, however, possesses the faculty of retaining for a time the impression received, and if a fresh pressure follows quickly upon the first, we are able to compare the strength of both impressions. But the remembrance of the sensory impression rapidly diminishes in strength, as may be proved by the above experiments, so that we cannot accurately distinguish a second impression from the first if the time between them is too great.

Weber has also examined the delicacy of the sense of pressure in different parts of the skin, and made experiments to discover whether the sense of pressure stands in any relation to the sense of touch—in other words, whether the skin's sense of pressure is developed similarly with its sense of locality. This is by no means the case. For the sense of pressure in the tips of the fingers is not much more delicate than that of the forearm, whilst the sense of locality in the tips of the fingers is nine times more delicate. Several parts of the skin—for example, the forehead and the skin of the stomach—have a tolerably delicate sense of pressure, whilst the sense of locality is not at all remarkable, the skin of the stomach in particular only possessing a very dull sense of locality.

When touching a body we not only feel its form and the pressure produced by the contact, but at the same time the degree of its heat. In ordinary language we say a body is cold, warm, or hot. This term is, however, purely subjective, for it is regulated by the impression which the temperature of that body has made upon our skin, and often, therefore, does not agree with the indications of the thermometer. We call that body cold

which draws warmth from our skin, that one warm which gives it warmth, and as our skin is at a temperature of 30–36° Cent. (88°–98° Fahr.) the zero of our perception of temperature lies rather high.

We know that in physics the idea of cold is unknown ; it only treats of the single force of heat, which is regarded as a vibration of molecules. Cold is something purely subjective, and only depends upon the temperature of our bodies. Cold-blooded animals must therefore have a perfectly different standard of perception to warm-blooded animals. The feeling of heat only lasts so long as a body imparts heat to a particular part of the skin ; if the temperature of the skin has become equal to that of the object touched, then the feeling of heat ceases. If we place our hand, the skin of which is generally rather cool, into water at 36° Cent. (98° Fahr.) then we shall experience a feeling of heat so long as heat is imparted to the hand. The hotter, however, the hand becomes, the less will be the feeling of heat. If we then plunge the hand into water at 30° Cent. (88° Fahr.) it will seem cold for the first moment, although it really possesses a moderate degree of heat, since now heat leaves the hand and is imparted to the water. If, however, the hand has been cooled beforehand in the air, then the water at 30° Cent. (88° Fahr.) will appear to us to be pleasantly warm. Our skin is, therefore, only a relative measurer of heat, and only feels absolute temperatures in an imperfect degree. If we grasp a piece of metal and a piece of wood, which have the same temperature, the metal feels considerably colder than the wood, although the thermometer would give the same indication for both. Metal is a good conductor of heat, and

extracts heat rapidly from the skin, whilst wood will do so but slowly. The rapidity with which loss of heat takes place in our skin has thus a great influence upon the degree of our perception of cold.

The power of the skin of perceiving the difference of temperature has, by Weber, been submitted to exact calculation. Place, for instance, the hand, or a finger, in water of different temperatures, and see to what extent it is able to mark the difference. Weber found that with the finger he could perceive a difference of about $\frac{1}{4}^{\circ}$ Cent. ($\frac{1}{2}^{\circ}$ Fahr.), a tolerably delicate sensibility, greater than we should have expected, since it is greater than that of our ordinary thermometer. And yet our indications for absolute temperature are very uncertain; it would be impossible for us to determine accurately the true temperature of water at 19° Cent. (60° Fahr.), it only being in our power to say that the temperature lay between 16° – 20° Cent. (51° – 68° Fahr.) The delicacy of our perception of relative temperature, when the trial is made quickly, is, however, nearly equal for all temperatures up to blood heat; but it is not the same in all parts of the body. It depends principally upon the thickness of the skin, for heat penetrates the thinner skin most easily. Thus the back of the hand is more sensitive than the palm, and the eyelids, lips and tongue are most sensitive of all. The elbow also possesses great sensibility, the reason of the well-known practice of mothers, who, in washing their children, will plunge their elbows into the bath to try its temperature. This may also be explained by the thinness of the skin, and the absence of fat in that part.

Moreover, we must also assume that there may be

in the skin certain organs of temperature, which have their own nerves and are more strongly developed in some parts of the skin than in others. For it has been proved that the nerve-trunks themselves have not the faculty of producing a feeling of heat, if heat is directly applied to them. For instance, a sensitive nerve runs directly under the skin of the elbow on the bone, which causes great pain if struck. Now if we place the elbow in hot water we experience a sensation of heat in the part immersed, not in the whole arm, although the nerve extends throughout the arm and hand. We experience, however, a dull feeling of pain in the whole arm if the water is too hot. Thus the nerve-trunk is irritated by heat, which irritation, however, does not create a sensation of heat, but pain. If the elbow is placed in ice-cold water this sensation of pain is just the same, proving that the nerve-trunk can neither feel warmth nor cold. The sensation of pain which occurs in this case is another reason why the elbow should be so sensitive to a great and injurious degree of heat.

We must, therefore, assume that the nerves of the skin possess certain organs of temperature which are adapted to produce an excitement of the nerve by heat. Such organs, however, have not yet been discovered, at least none are recognised as such. It may be that the tactile corpuscles as well as producing tactile impressions may assist our sense of temperature; but nothing certain can be said on this point. Weber has discovered the interesting fact that warm bodies appear lighter than cold bodies. If a cold coin is placed upon the forehead of some person whose eyes are shut and then upon the same spot two

warm coins, the weight would seem to him the same, whilst he could distinguish cold weights correctly. A connection seems, then, to exist between the sense of temperature and the sense of touch, but it has not yet been scientifically examined.

PART II.
THE SENSE OF SIGHT.

CHAPTER I.

Formation of the Eye—Refraction of the Light-rays in a Lens—Path of the Light-rays in the Eye.

WHILST we can only become acquainted with the presence of bodies through the organ of touch, when we bring the surface of our skin in direct contact with them, we can perceive through the eye, bodies at a greater distance, by means of what we call light. It almost seems as if no limit could be set to the passage of light through space. We receive rays of light from stars in the remotest spheres of the universe at an incalculable distance, and are thus informed of their presence. Indeed we are now enabled, by means of spectrum analysis, to determine their chemical composition. Moreover, to whatever distance a ray of light penetrates through space, as long as it possesses a certain intensity, it is able to produce an impression upon our organs of sight, and thus opens out to us a region of knowledge, the limits of which are far wider than those which enclose the domain of the other senses.

Physics teach us that light is transmitted by the

Ether, a substance of extraordinary tenuity, which extends throughout the universe, penetrates all substances, exists also in empty space, and that it is produced by vibrations of the ether of extraordinary rapidity. As these vibrations reach the interior of the eye through its transparent organs, they produce in us a sensation of light, and by means of the wonderful formation of the eye, we are not only able to receive the impressions of light emitted by bodies, merely as such, but also to perceive their form, size and nature.

Let us now proceed to study the most important parts of the eye.

Fig. 7 represents a horizontal section of the right eye, after Helmholtz, which will explain to us all the important parts of this organ, which nature has endued with such wonderful delicacy. We here see the eye-ball surrounded by a hard membrane, *m n*, called the *sclerotic coat*, which in living persons appears as the so-called *white of the eye*, in the anterior segment between the eyelids. The membrane is rather thick and strong, and provides the eye with a sufficient protection from external dangers; it is not transparent but perfectly translucent in a strong light. At the outer edge of the eye it passes into the *cornea*, *h h*, which is almost equally thick, but is distinguished by its glass-like transparency. This membrane rises and thickens in the middle like a watch glass, and also forms the transparent covering to the eye, through which the light passes into the interior.

Now in the interior there follows upon the sclerotic coat a far thinner and more delicate membrane, coloured deep black, *g*, called the *choroid*, because it contains a great number of blood-veins. Its black colour, however, pro-

ceeds from a considerable number of black pigment-cells, which are arranged like a mosaic upon its inner surface. This membrane joins the *iris*, *pp*, which is visible in every living eye, and which contains a dark opening, the *pupil*. Through this opening the light passes into the

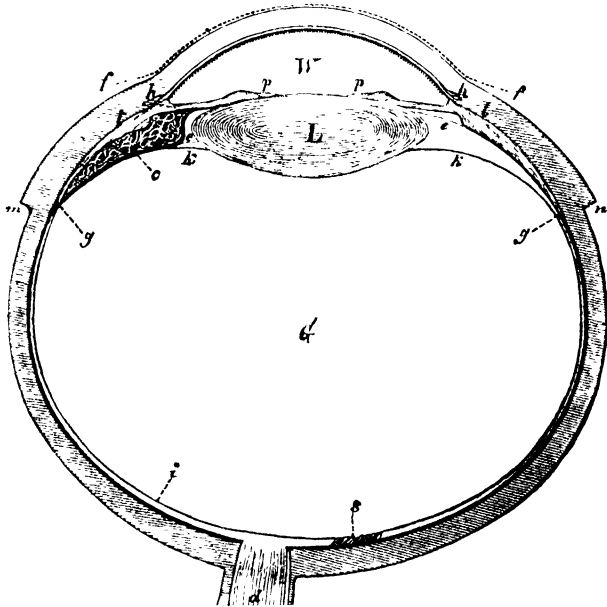

Fig. 7.

interior of the eyeball and reaches its posterior wall. The black colouring of the choroid is a great assistance to the eye's vision. Were it absent, the light, which falls upon the background of the eye would be reflected as from any other bright surface; a number of rays of light would thus be distributed irregularly in the eye, and

so dazzle it, besides considerably injuring the distinctness of the image in the eye. The iris is also provided with black pigment similar to that of the choroid, and assumes a lighter or darker colour, according to the number of these pigment-cells. In a blue eye the iris has only a thin layer of pigment-cells on its posterior surface, and has, therefore, a bluish appearance from the outside. The greater the number of pigment-cells the darker is the colour of the eye ; this variation in the amount of pigment is the cause of the different shades which we see in eyes, from the darkest brown to the lightest blue or grey. In all races of men individuals may be found in whom this pigment is wanting, not only in the eye, but throughout the body, in the hair and skin ; such people are called *Albinos*. The want of this pigment in the eye injures the sight in a remarkable manner. The iris has a whitish-red appearance, the pupil is generally bright red, and the dazzling effect of the daylight causes a winking of the eyelids, which is an endeavour to replace the protection of the pigment which is wanting. We also find albinos among animals : for example, the white rabbit, upon whose eyes many interesting observations may be made. Thus, for instance, a delicate reversed picture of the surrounding objects may be seen upon the posterior surface of an eye freshly extracted from such an animal, shining through the transparent coat of the eye, whilst this is not the case with the dark-coloured eye of another animal.

Now within the choroid is situated a delicate membrane called the *retina* (fig. 7, *i*). It forms the continuation and extension of the optic nerve, which, like the stalk of an apple, penetrates the posterior side of the

eye in a somewhat slanting direction with the side of the nose, pierces the sclerotic coat and choroid, and then spreads out on all sides, so as to form, by means of the peculiar terminations with which it is provided, a kind of nerve-carpet, which is the most delicate sensory organ created by nature. The retina, towards the front of the eye, touches with its edge the outer circumference of the iris, and lies quite open to the transparent interior of the eye, so that the rays of light fall directly upon it, and create in it an impression of light. Before, however, the rays of light reach the retina, they pass through a number of transparent organisations which are situated in the circular hollow of the eye, and are here ingeniously fitted together like the parts of a microscope or telescope, with this difference only, that they are packed tightly together, so as to allow no trace of air between them. The outer covering of this transparent body is the cornea, mentioned above; then, towards the interior, follows first the *aqueous humour*, w, secondly the *crystalline lens*, l.; and thirdly, the *vitreous humour*, g. The aqueous humour fills, as we have seen, the space between the cornea, the iris and the lens. Directly behind the iris lies the crystalline lens, l., so well known, and resembling a very thick burning-glass. It is more convex upon its posterior than upon its anterior surface; in a living eye it is as clear as crystal, and consists of a somewhat soft substance, which becomes harder towards the back of the lens. It has been discovered that this substance is not the same throughout, but that it consists of small vessels which are arranged in intricate lines, thus giving a sex-radiated structure to the lens. The lens, however, does not lie unconfined behind the iris, but is enclosed in a

transparent capsule, which, again, is held in position by a peculiar elastic membrane, *k k* and *c e*, of which more hereafter. It is sufficient to say here that this membrane joins the circular *hyaloid membrane*, which lies directly upon the retina. The spheroidal space between the lens and the retina is filled by the vitreous humour, a clear gelatinous mass, which is directly surrounded by the hyaloid membrane.

The rays of light, therefore, which fall upon the eye penetrate the cornea, the aqueous humour, the crystalline lens, and the vitreous humour, before they reach the retina, and on their way are refracted in such a manner that they unite into a distinct picture upon the background of the eye.

It is well known that with the aid of a glass lens we can throw a representation of any object upon a screen. If, for example, we take the front convex lens out of a pair of opera-glasses, and, holding it opposite a window, place a piece of paper behind it to act as a screen, a small reversed image of the window will appear upon it, which, upon holding the paper at a certain distance, will become clear and distinct. Again, the camera obscura is well known, which in its simplest form consists of a box, in one side of which a convex lens is fixed in an opening, while the opposite side consists of translucent paper, or a piece of ground glass on which the picture is formed. In principle the action of the eye resembles that of a camera obscura, which is commonly used in the production of photographic pictures; but the eye, as we shall see, is in many respects much more perfect than the camera obscura.

The manner in which a convex lens is able to

produce an image of an object is seen in fig. 8. Let the arrow AB represent an object at a certain distance from the lens, F and F' represent the foci of the lens, the distance of which is easily found by allowing a sunbeam to fall upon the lens, and finding the point of convergence upon a screen, which with a strong glass is very bright and hot. In the focus all the rays unite which are parallel to each other, and fall perpendicularly upon the lens; and, on the other hand, when rays of light fall upon the lens from the focus they take a parallel direction on the other side. The upper point B

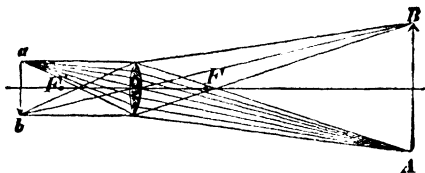

Fig. 8.

of the object, amongst others, sends a ray upon the lens which passes through the centre O . This ray suffers no refraction, because the lens stands in the same relation to it as if it were a pane of glass bounded by parallel surfaces. A second ray passes through the focus F , strikes the lens, and is continued on the other side in a line parallel to the line $F'O$, which is called the optical axis. Both rays meet in the point b , and here, therefore, an image of the point of the arrow is formed. The image of the head of the arrow a is formed in exactly the same manner, as may be seen from the figure, and thus a reversed image of the object is formed, which decreases in size the further the object

is removed, and which, when the object stands at an immense distance, as, for instance, the sun, contracts to a single point—the focus.

Fig. 9 shows a camera obscura as it is used by photographers. In the brass tube *h i* is the lens; *g* is the ground glass plate upon which the image is to be received, and the case *a b* consists of two parts, which slide in and out, and enable us to find the position of the image for objects at different distances. Besides this, there is a screw on the brass tube which allows

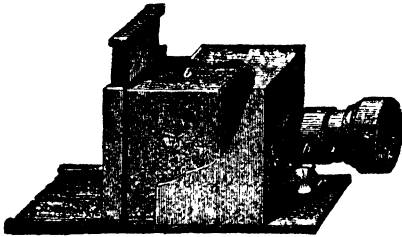

Fig. 9.

the lens to be moved backwards and forwards, so that the picture may be sharply defined upon the glass plate. We shall see that the eye also possesses an apparatus which serves the purpose of forming distinct images, but which acts in a very different manner.

The refraction of the rays of light in the eye is much more complicated than in a simple convex lens; for, in the eye, the ray of light passes through several substances, and is refracted at the surface of each substance. The common result, however, produced by all these refracting media of the eye is exactly the

same as in a simple convex lens, and a small inverted image of the external object is formed upon the retina, which, as we have already seen, may be plainly perceived shining through the extracted eye of a white rabbit. There are three principal surfaces by which the rays of light are refracted: the outer surface of the cornea, the anterior and posterior surfaces of the lens. The most powerful refraction takes place at the outer surface of the eye, because here the rays of light pass from the rarified medium of the air to the dense medium of the cornea and aqueous humour, both of which possess about the same refractive power. This power is greater in the lens than in the aqueous humour, or in the vitreous humour, so that in passing through the eye the rays of light are still more strongly deflected inwards. The refracting power of the lens is increased by the fact of its consisting of concentric layers, the inner of which refract more powerfully than the outer. It has been calculated that a greater effect is thus attained than if every part of the lens had the same refracting power as the centre of the lens.

We now see clearly that the image formed in the eye is due to causes somewhat different to those which produce the image in the camera obscura. In the latter we have only to deal with a single refracting body surrounded by air. In the eye, on the contrary, the ray of light passes from the air into a number of refracting substances without passing again into the air, the picture here being formed behind the vitreous humour, upon the retina. The path of the refracted rays is, therefore, much more complicated in the eye than in a glass lens; but still the analogy is sufficient

for a general examination of the path of the rays of light in the eye.

The distinctive feature of the central point of a convex lens (fig. 8) is the fact that rays pass through it without suffering refraction. In optical language this point has, therefore, been called the *optical centre*, and in a double convex lens of equal curvature this point coincides with the geometrical centre. It is different, however, in a double lens of unequal curvature, and still more complicated in a system of refracting media, like those which we meet with in the eye. From the mathematical calculation of Listing, it appears that even in a system of this kind a point exists through which the rays pass almost without suffering refraction; this point, which is called the *optical centre of the eye*, lies in the crystalline lens, not, however, exactly in its centre, but between that point and the posterior surface of the lens. A luminous ray passing through this point reaches the retina without refraction, at least, with such a slight refraction, as to be of no real consequence. In fig. 10 k is the optical centre

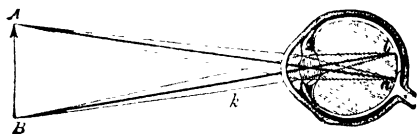

Fig. 10.

of the eye; let AB be an object, then the rays $Ak a$ and $Bk b$ will reach the retina without refraction. Now the size of the eye has been so fixed with regard to the refracting media, that within the limits of vision

the image of an object is formed nearly at the distance of the retina; and, moreover, the eye possesses the property of adjustment for different distances. If, therefore, the eye is adjusted to receive an impression of the object *A B*, then all the rays emanating from *A* will unite in a point *a* upon the retina, and those from *B* in the point *b*, and form upon the retina a small reversed picture *a b*. It is evident from the figure that all rays which do not pass through the optical centre are refracted so as to unite into an image upon the retina.¹

When we look at a very distant object, a star for instance, the rays fall parallel upon the eye, and since they are united to a single point upon the retina, it follows in this case that the focus of the media of the eye falls exactly upon the retina. So perfect is, therefore, the formation of the eye, that the form of the refracting surfaces and the refracting power of the eye are exactly proportioned to the distance between the retina and the outer surface of the cornea. This is, of course, only the case with a normal eye, the relative proportions being different in a short-sighted or long-sighted eye.

In this manner images of all kinds of objects are formed upon the retina. The iris here plays an important part, since it increases the distinctness of the image. It serves as a kind of screen to the eye,

¹ In order to trace exactly the path of a ray in the eye, two optical centres must be found by calculation, a line must then be drawn from the luminous object to the first optical centre, and one parallel to it from the second centre to the retina. These two centres are situated very near to each other, and can practically be taken as a single centre.

covering the edge of the lens and excluding the marginal rays, which, in every lens, render the picture indistinct, because their focus does not exactly coincide with that of the rays which pass through the central part of the lens. A similar screen is used in all optical instruments, in telescopes, microscopes, and in the camera obscura; otherwise the pictures are seen with indistinct edges. The iris, however, is a screen of a much more perfect description than those which are used in our instruments. It not only excludes the injurious marginal rays, but it also regulates the amount of light which is sufficient and necessary for the eye. When we direct the eye towards a luminous object, the sky or a flame, the pupil contracts, and enlarges considerably when we look in the dark. This contraction may be easily observed if a person is placed before a bright window with his eyes shaded by his hand, and the hand is suddenly removed. The pupils are considerably larger in the twilight than in broad daylight. In this manner the quantity of light which penetrates the eye is regulated, for the smaller the pupil the smaller is the quantity of light which penetrates it from any one point, and the larger the pupil the greater also will be the quantity of light. Night-birds, such as owls, are remarkable for their wide pupils, which enable them to see well in the dark, whilst they shun the daylight because they are blinded by it.

If we return once more to our comparison of the eye with the camera obscura, we are struck with another advantage which it possesses over the latter instrument. This advantage lies in the fact that the

background of the eye is a concave surface, whilst the surface of the ground glass plate which receives the image in the camera obscura is plane. The advantage to the eye is here twofold, which will immediately strike anyone who has examined a picture in the camera.

The image which a convex lens produces of a large body with perpendicular lines, as, for instance, the arrow in fig. 8, is not perfectly perpendicular, but slightly curved, and this curvature may be exactly calculated by drawing a circle round the centre of the lens at the distance of the picture. Let us suppose the whole field of vision to be depicted by a lens, then the image formed by the lens is not thrown upon an even surface, but upon a concave surface, whose centre lies in the lens. This accounts for the lines towards the edges of the picture in a camera obscura never being perfectly perpendicular, but always more or less curved. This may be seen very plainly in photographs where the vertical side of a house is represented near the margin. This defect is not very great if the image lies near the optical axis ($F F'$), but as soon as the images are situated at too great a distance from it, they appear distorted and indistinct. This is the reason why the size of photographic pictures is limited, and that it is only possible to represent a small portion of the field of vision. It is different with the eye, since it possesses a concave background upon which the field of vision is depicted, and with which the curved form of the image coincides exactly. Thus the defect of the camera obscura is entirely avoided; for the eye is able to embrace a

larger field of vision, the margins of which are depicted distinctly and without distortion. If the retina had a plane surface, like the ground glass plate in a camera, it must necessarily be much larger than is really the case if we were to see as much; moreover, the central portion of the field of vision alone would give a good clear picture.

CHAPTER II.

The Adjustment of the Eye—Short Sight and Long Sight.

WE know from experience that we are able to see distinctly objects at different distances from our eye. But on careful observation we shall find that we cannot form simultaneously a perfect picture of objects at different distances from us. Suppose that we are in a room at a little distance from the window, and that we then hold up a finger a few inches before one eye, and close the other; if we now fix the eye steadily upon the finger so as to see it distinctly, the window in the background will be seen indistinctly. If we fix our eyes upon the window frame so as to see it distinctly, then the outline of the finger becomes indistinct, so that we can see distinctly at will either the window frame or the finger. Thus the eye is adjusted for objects at different distances, and this property of the eye is called its *adjustment*. When our eyes are wandering over objects at different distances from us, this adjustment is constantly at work, although we are quite unconscious of it ourselves.

In fig. 8 the image of the arrow A B is depicted at *a b*. If, however, the object A B is at a greater distance,

then the image $a b$ will be formed nearer the focus F' , at the same time becoming smaller. The position of the image changes with that of the object. When, therefore, a picture is about to be produced in the camera obscura, the inner case b containing the ground glass plate g must be moved forward into the outer case a for distant objects, and drawn out again for near objects. By means of the screw r the lens may be moved a little backwards and forwards, which will still further ensure the clear delineation of the picture. This also applies to the eye. The object $A B$ in fig. 10 may be depicted quite clearly at $a b$ in the eye. If the object approaches or retreats whilst the eye remains in the same position, the picture of the object will become indistinct, because in the first case it would be formed before, and in the second behind the retina.

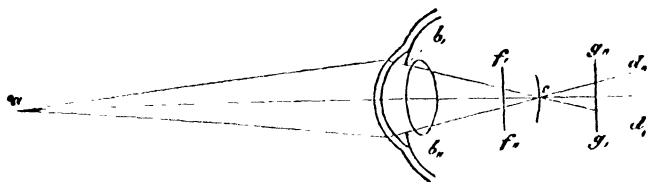

Fig. 11.

Let us suppose a luminous point a , fig. 11, to be at a certain distance from the eye, then a distinct image of this point will be formed if the retina lies at the point of convergence c ; if, however, the retina is at a greater distance at g, g'' , so that the focus is formed in front of it, then, instead of a point, a blurred circle is produced. A similar blurred image would be formed

upon the retina if it lay at f, f'' , in front of the image, and if all the points of an object were not depicted upon the retina at their foci, the whole object would appear indistinct and blurred. The experiment, which we mentioned at the commencement of the chapter, may be easily explained in this manner. When the eyes are fixed upon the finger the image of the window frame behind it does not fall upon the retina at the focus of the rays it emits, and conversely, if the window is fixed by the eye, the finger appears blurred for a similar reason. The image of the body which we see distinctly always falls upon the retina, whilst the image of the body which we see indistinctly would fall in the first case before, and in the second behind the retina. From this the important inference is to be drawn, that the eye possesses a power of adjustment, by means of which objects at various distances are depicted distinctly upon the retina.

We might very well be inclined to think that the method employed for this adjustment of the eye should be similar to that employed in the camera obscura. It was formerly considered as possible that in the process of adjustment the retina moved backwards and forwards by the elongation of the eye-ball, through the action of muscles in the socket, so that the background of the eye could with equal ease be moved in either direction. This supposition has, however, been refuted, and it has been shown that the method employed is quite different to that of the camera obscura, and so perfect that it cannot be imitated artificially. Let us suppose the eye to be adjusted for a great distance, such as some point upon the horizon, or in the sky. The rays

from this point will penetrate the eye in almost parallel lines, and will, therefore, unite at the focus of the eye, which, in a normal eye, lies exactly in the central point of the retina. If, however, the object we are looking at is nearer the eye, then, according to the laws of optics, its image will fall beyond the focus of the eye, and, therefore, behind the retina. The eye, however, is enabled by adjustment to bring the point at which the image is formed back to the retina, which can easily be explained by a greater convergence of the rays which penetrate the eye, or in other words, they must suffer greater refraction in order that they may meet sooner than they would if they suffered less refraction, and thus produce a distinct image upon the retina.

The reason why the light-rays suffer a stronger refraction when the eye is fixed upon nearer objects is, that it has been observed, *that when the eye, after viewing a distant object, views a nearer one, the crys-*

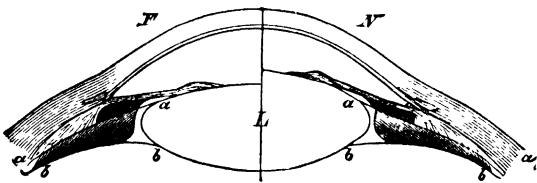

Fig. 12.

talline lens becomes thicker by an increase in the curvature of its anterior surface. Fig. 12 shows the alteration in the curvature of the lens when a near object is looked at, after a drawing by Helmholtz.

The left portion of the figure represents the eye adjusted for distant objects, whilst the right half represents it adjusted for near objects. We here see that the anterior surface has increased in convexity, and is pushed forward nearer the cornea, taking the iris with it. This advance of the iris may be easily observed, by watching from the side the eye of a person whilst the distance of objects he looks at increases.

The stronger refraction of the rays, which takes place when we look at near objects, can undoubtedly be explained by the motion of the lens which has just been described. According to the laws of optics the refraction of the light-rays caused by a convex lens increases with its increase of curvature. The distinctive feature between two lenses of equal size, one of which is flat and thin, the other thick and of greater curvature, is that the focal distance is greater in the former than in the latter, or in other words, the latter produces a greater convergence of the light-rays. The case is similar in the crystalline lens during adjustment. When the same object of our vision is at a small distance the lens is more convex than when the distance is greater, and its refracting power is so much increased, that the image is again formed upon the retina instead of behind it. The curvature of the lens, of course, differs with every variation in the distance of the objects seen, increasing with their approach. In ordinary vision these alterations of the lens are performed as rapidly as the changes in the direction of our vision, and through constant exercise they are performed with such exactness, that we are able to form a distinct image of every object upon the retina.

We must now enquire further into the mechanism by which this change in the form of the lens is produced. It is produced by means of a muscle, which is shown in fig. 7. It lies at *t* where the choroid runs into the iris. Its fibres are not directly connected with the lens, but its formation is somewhat complicated, and, therefore, its action in producing adjustment has long been a matter of discussion. Helmholtz has explained it in the following manner. The lens is attached at its edge to a *radiating zonule* (*zonula zinnii*), which radiates outwards and maintains the lens in tension (as represented in the figure by the line *c*). Now, at the point where the fibres of this ligament are attached to the outer membrane of the eye, are also attached the fibres of the muscle¹ which produces adjustment. In viewing distant objects this muscle is relaxed, and the zonula, by means of its elastic tension, extends the lens in a radial direction towards the edge, thereby diminishing its thickness and flattening its curvature. In adjusting the eye for near objects the zonula is drawn inwards towards the edge of the lens by the muscle; its tension, therefore, decreases, and the lens contracts by means of its elasticity, and consequently its thickness and exterior curvature are increased. We experience thus no muscular exertion in viewing distant objects, the elastic tension of the lens and of the zonula alone preserving equilibrium. In looking at near objects, on the contrary, a muscular effort takes place in the eye, and, therefore, in viewing near objects

¹ *Ciliary muscle*, or, *Musculus tensor choroideæ*—so called from its drawing forward the edge of the choroid.

the eye is undergoing muscular exertion, but in viewing distant objects it is in a condition of rest.

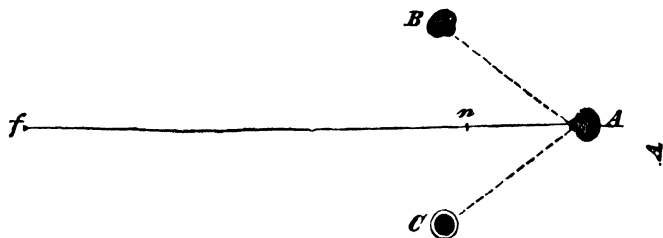

Fig. 13.

The question as to the means by which the thickening of the crystalline lens, when viewing near objects, can be recognised, is still unanswered. The contraction of the iris with which it is connected is, indeed, easily observed, and at the same time the pupil may be seen to decrease in size. Still this does not perfectly prove the increase in the curvature of the lens. The action may be detected with certainty by an observation of the image reflected by the eye.

The small reflected image of surrounding objects which may be seen in the eye is well known to everyone. These images, which are very distinct and perceptible are produced upon the anterior surface of the cornea, and present the appearance of small, upright and somewhat distorted pictures, exactly similar to those which are produced upon reflecting balls often seen in German gardens. We have here to deal with one of the properties of convex lenses. Upon a closer examination of the eye reflected pictures will also be observed upon the

anterior and posterior surfaces of the lens, which are not, however, so distinct as that upon the cornea. In order to see them the following experiment may be made in a dark room. Let a candle *C* (Fig. 13) be placed near to the eye under observation *A*. The eye of the person making the observation will be at *B*, whilst the eye *A* looks in the direction of *f*. *B* will then see three reflected pictures in *A*, which will have the appearance represented in fig. 14. A distinct image (*a*) formed upon the cornea will be first seen against the dark background of the pupil; then an image (*b*) on the anterior surface of the lens, also upright and somewhat larger, but much fainter; and thirdly a smaller image (*c*), reversed but rather more distinct, on the posterior surface of the lens. The last image is seen reversed because it has been reflected by a concave mirror, whilst the first two were reflected by convex mirrors.

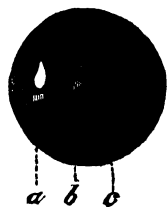

Fig. 14.

Now a marked difference will be observed in the image *b* on the anterior surface of the lens as soon as the distance of the object viewed changes from *f* to *n*. In the adjustment of the eye for the near object the picture becomes smaller and more distinct, but in adjustment for the distant object the picture appears larger and more indistinct. The inference to be drawn from this is, that according to the laws of optics the curvature of the surface of the lens must have increased when the eye was fixed upon the near object; for the greater the curvature of a convex lens, the smaller will be the picture which is reflected. The two other pictures, *a* and *c*, on the con-

trary, remain the same during the process of adjustment, and it follows that the curvature of the cornea and of the posterior surface of the lens must remain the same.

If we bring an object very near to the eye and try to see it distinctly, for instance the print of a book, we shall find that there is a limit beyond which we cannot see anything distinctly, however great an effort we make. This point, which is at a distance from the eye of about 4 to 5 inches, is called the *near-point* of the eye. By means of a very interesting experiment, known as Scheiner's, the distance of this point for every eye may be exactly determined.

Take a piece of cardboard and make two small holes in it with a needle at a distance of about $\frac{1}{12}$ of an inch apart. Now, if the holes are held close to the eye, and the needle behind the holes, two needles will be seen side by side, if the needle is held very near to the piece of cardboard. But if the needle is gradually moved further off, a point will be found where the two images combine into one, and that point is the near-point of the eye.

The accompanying figure (fig. 15) will explain the phenomenon. The eye is represented by the lens b , and before it is placed a screen in which are two holes e and f . The luminous point a sends two pencils of light through these holes to the lens, which combine at c , forming an image just at the point where the screen $n n$ represents the retina. If, however, the retina were placed at the point $m m$, then two pictures of the point a would be formed at p and q , which would both be less distinct than the image formed at c . Now this is the case in the

experiment mentioned above when the needle is held so near the holes that the two pencils have not united upon the retina. The eye then, even with the greatest effort, cannot increase the refracting power of the lens sufficiently to adjust it for the needle. If, however, the point is found at which it is possible to see one image only, this point will clearly be the near-point.

Moreover, it is interesting to observe that when we perceive two images p and q , the image q , which is

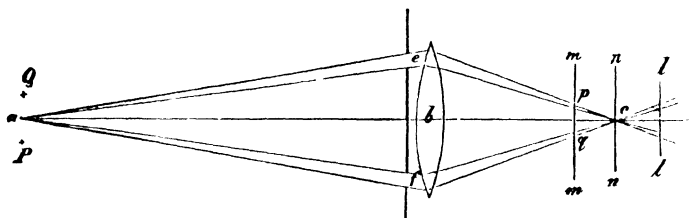

Fig. 15.

formed by the lower hole f , appears above somewhere near Q , whilst the picture p appears below somewhere near P . For if the hole f is covered Q disappears, and if e is covered P disappears. The reason is simple. The picture formed upon the retina is, we know, an inverted one. Therefore what is depicted upon the lower part of the retina is found in the upper part of the field of vision, and that which is depicted on the right, in the left, and *vice versa*. Therefore in our imagination the retinal picture q is transposed to Q , and the picture p to P .

For the success of the experiment it is important to take care that the distance between the two holes should not be greater than the diameter of the pupil, else the

two pencils of light will not both be able to penetrate the eye. By an instrument founded on the principle of this experiment, the *Optometer*, in which one cylinder is moved within another, as in a telescope, the near-point may be determined with perfect accuracy,

Now, in most cases, there is also a limit to distinct vision when the eye is adjusted for distant objects. It is indeed possible for persons with perfectly healthy clear-sighted eyes to see objects with clearly defined outlines at any distance within the horizon, and they are therefore able to adjust their eyes for infinite distances. Many people, however, cannot do this, that is to say, they are more or less *short-sighted*, and there is a certain distance where their distinct vision ceases. This point is called the *far-point* of the eye.

The far-point of the normal eye is at an infinite distance. When the parallel rays of an object at an infinite distance, a star for instance, fall upon the eye, they unite in the focus of the eye, which in a normal eye would be exactly at the retina. It is evident, however, that this ideal formation is seldom met with, from the fact that people imagine that a star radiates light, whilst in reality it is only a luminous point. In the short-sighted eye, the focus lies more or less in front of the retina within the vitreous humour; this is caused by the diameter of the eye, and particularly the lens, along the line of its axis being too great in comparison to the refractive power of its media. Now if a luminous point is moved towards the eye, then according to the laws of optics, the image will be removed from the focus towards the retina, which, however, it will not reach till it has been moved to within a certain distance from the eye.

For very short-sighted persons it is well known that this distance is exceedingly small, so that they are not even able to form distinct images of objects in a room. The far-point for the eye of a short-sighted person will therefore be the point where the image of objects is imprinted exactly upon the retina, whilst every point at a greater distance will only produce a hazy image.

Short-sighted persons make use of spectacles consisting of concave glasses to enable them to see distinctly at a distance. These glasses have the peculiarity of increasing the divergence of the rays of light, so that the convergent rays which fall upon them will intersect each other so as to form an image at a greater distance. Fig. 16 shows that rays which converge at the point B will, by a concave glass, be made to converge at the point A. Let us suppose that in a short-sighted eye the image of a luminous point has been formed at B, and that the retina lies behind it at A; now by making use of a pair of concave spectacles, the image will be formed upon the retina. The more short-sighted a person is, the more concave must his spectacles be, to increase the divergence of the incident rays to such an extent that the image may be formed upon the retina.

Another very frequent defect in the eye is *long-sightedness*. The structure here is the opposite of that just described, and consists in the focus of the eye lying behind the retina. When, therefore, parallel rays, as for instance those from a star, fall upon the eye, they do not unite until they have passed beyond the retina. Persons so affected, however, are generally able, by adjusting the eye, to move the image forward, and thus to see distant objects distinctly. Near objects however they see in-

distinctly because they cannot sufficiently adjust the eye so as to form the image upon the retina, therefore the near-point for them must be at some distance from the eye. Long-sighted persons consequently use convex glasses, to enable them to see near objects distinctly, for a convex lens converges the rays, and brings them sooner to a focus, and therefore moves the image forward. When a long-sighted person wishes to read, he must either put on his spectacles or hold the book at some distance till it reaches his near-point, whilst on the other hand a short-sighted person can read quite well without spectacles, if he only holds the book near enough to his eyes.



Fig. 16.

Short-sighted persons can see objects when placed close to the eye even better than those who enjoy normal sight, because their near-point lies nearer to the eye, and all objects apparently increase in size as they approach the eye.

Another less striking defect, which is seldom met with in a normal eye, but is often strongly developed in cases of illness, is caused by the unsymmetrical formation of the interior of the eye. In looking at the concentric circle (fig. 17) with one eye, we shall observe that the lines are never all distinct at the same time, but, as we adjust the eye, two opposite sections will alternately appear clear and distinct as their positions

change. From this it follows that the curvature of the eye is not exactly the same in a horizontal and vertical direction. Consequently, rays from vertical lines have a different focus, or point of convergence, to rays from horizontal lines. Thus, for instance, in the adjustment for

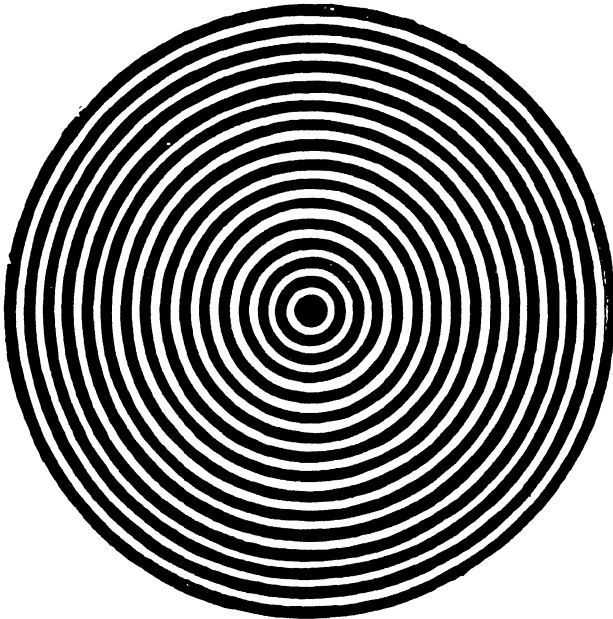

Fig. 17.

horizontal lines, vertical lines at the same distance will appear indistinct, and *vice versa*. This is the case in the figure of the concentric circle, since the horizontal and vertical directions of the lines merge into each other.

One other circumstance may be mentioned which

takes place in the refraction of light in the eye. •It is well known that inferior opera-glasses and telescopes represent objects with coloured edges, and, in order to avoid this defect, so-called achromatic lenses are made use of, which are constructed so as to prevent the resolution of light into coloured rays. Every common lens gives images with coloured edges, because the points of convergence of the coloured rays, of which white light is composed, do not coincide, the refrangibility of each colour of the spectrum increasing from red to blue.

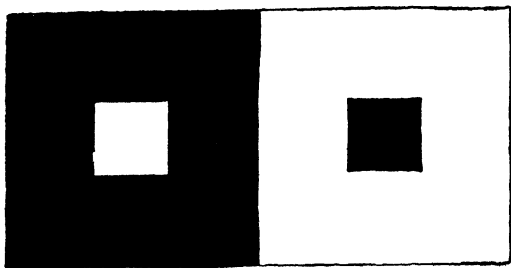

Fig. 18.

Thus we cannot at the same time see a red line and a contiguous blue line distinctly; for when the eye is adjusted for the red line the image of the blue one lies in front of the retina, and when the eye is adjusted for the blue line the image of the red one lies behind the retina. Now the eye is not a perfect achromatic instrument, although objects do not appear with coloured edges in ordinary vision. If we look at the sharp edge of a dark object against a white surface, as, for instance, the horizontal bars of a window frame against a cloudy sky, the upper edge will appear of a yellow tinge and

the lower one of a blue tinge, particularly if we do not carefully adjust the eye for it. The coloured rays are seen here, as in optical instruments, because the resolved rays are not hidden by the edge of the window frame, whilst within a white surface the rays overlap and reform white light.

From an insufficient power of adjustment bright objects, if seen against a dark ground, at a certain distance from the eye, will appear to be surrounded by a coloured fringe, which causes the light surfaces to appear larger than they really are. This phenomenon is called *Irradiation*. If, for instance, we look at the two equal squares in fig. 18, the black one on a light, and the light one on a dark ground, at a little distance from the eye the latter will look larger than the former. In fig. 19 the two white squares, when seen from a little distance, will appear to run into each other, and to be joined together by a white bridge, since the resolved rays overlap. It is a well-known fact, that people look larger in light clothes than in dark, which may also be explained as the effect of irradiation. This circumstance is not unknown in the art of dress, but is carefully studied. That a black dress contributes to an elegant figure, ladies know very well.

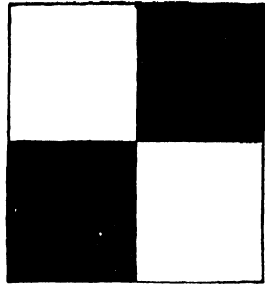

Fig. 19.

CHAPTER III.

Recognition of the Interior Portions of the Eye—The Ophthalmoscope.

THE retina is the point where the physical process of vision passes into the physiological process. Until it impinges upon the retina, the light which penetrates the eye has only undergone physical changes, consisting chiefly in refraction, the last perceptible result of which is the production of the image upon the retina. From this point the process passes from our immediate observation, and the difficulty of discovering its character increases at each step. The image upon the retina is reversed, and yet we see every object in the field of vision upright. This is the result of the experience, which we have acquired from childhood, in the exercise of the organ of sight. The point *A* (fig. 10), which is on the right, is imprinted upon the left portion of the retina, and we therefore know by experience that a ray coming from the right must strike the left portion of the retina; and because we always imagine the objects we see to be external to ourselves, we must do so by unconsciously following the line *a A*, through the optical centre *k*. In this manner the eye projects a uniform field of vision, which i

obtained by drawing, from every point of the retina outward, straight lines through the optical centre of the eye, which lines will terminate upon a convex surface.

This is really the manner in which the eye interprets, in all cases, its sensations of sight. For luminous appearances may be produced, without our perceiving any external object, but merely a part of the eye or an inward irritation; and yet, in the same manner, we imagine them to be external to ourselves.

If we shut the eye and press the head of a pin upon the outer edge of the eyeball, we shall see in the dark field of vision a white or coloured spot of light, which has the same form as the compressing body: it will be seen upon the left side of the field if the right side is pressed, and upon the upper half if the lower is pressed, and *vice versa*. The retina, therefore, extends as far as the part which projects beyond the socket of the eye, and can be irritated by pressure. It is well known that when the eye is struck, a cloud of sparks is seen, which is caused by the mechanical concussion of the retina. These luminous images, often perceived involuntarily, take, speaking scientifically, the form of the body producing the pressure; at the same time we observe the relation between the position of the irritation and the position of the sensation of sight. We transpose a point on the left side of the retina to the right, because we imagine that a ray of light has penetrated the eye from the right, which must fall upon the left half of the retina.

We are also able to perceive particles within the interior of the eye, which are found in the transparent media. There are many persons who always see round particles

or filaments, which seem to float about in the field of vision. They may be more distinctly seen when looking upon a bright surface—a cloudy sky, or through a microscope. They follow every motion of the eye, and have, moreover, a peculiar motion of their own. These particles are produced by filaments and cells, which may be found floating about in the narrow space between the hyaloid membrane and the retina. They cast their shadow directly upon the retina, which then, from experience, refers them to external objects.

It has also been discovered by more careful observation that the refracting media of the eye are not absolutely transparent, but that a kind of cloudiness is seen in places which throws a shadow upon the retina. If we look at the sky through a small hole in a sheet of paper, held a short distance from the eye, the hole will appear to be surrounded by a coloured fringe. This is caused partly by a cloudiness in the vitreous humour, and partly by the peculiar radiating formation of the lens, already described. All such phenomena are called *entoptic*, because they deal with the perceptions of the internal portions of the eye. They are produced by the incident rays of light casting shadows of these particles upon the retina. They are best seen when an isolated pencil of light, like that admitted through a small aperture, is allowed to fall upon the eye; for, in that case, the shadows produced are distinct, whilst they are generally obliterated in ordinary vision, because the light penetrates the eye from all sides.

One of the most interesting entoptic phenomena is the *Arborescent Figure*, discovered by Purkinje. If, towards evening, we place ourselves opposite a dark wall in

a dark room, and move a lighted candle to and fro before our eyes, looking, however, fixedly at the wall beyond, we shall then, after a little practice, see this arborescent figure, whose intersecting branches cover the whole of the dark space, and which is unmistakably caused by the blood-vessels in the interior of the eye. The field of vision assumes a reddish appearance, upon which the veins stand out in dark shadows. The trunk of the figure rises a little on one side of the centre, where the optic nerve enters the eye, and thence branches out after the manner of blood-vessels, which is undoubtedly a proof that in this experiment we see the blood-vessels of the retina itself. One spot alone is free from vessels: the yellow spot, which is the most sensitive to light of all parts of the retina. If now the candle is moved to and fro, the figure will also move, and follow the direction of the light.

All these observations lead to the conclusion, that we are thus enabled to perceive the shadows of the vessels of the retina. That these vessels cast a shadow behind them is clear, but that the shadow should be sufficient to cause a perception, leads to the very important and interesting fact, that the elements of the retina which receive the impression of light, must lie behind the blood-vessels. The diagram in fig. 20 will explain how the shadow of a vessel can produce an image. If the light is placed at *a*, its image will be depicted upon the retina at *b*. At this particular spot no vessels will be seen, because the light is too dazzling. But the image at *b* forms another source of light, and if there is a vessel at *v*, then its shadow will be thrown upon *c*. Now, the retina projects the image perceived at *c*, outwards, through the optical

centre k , to d , where the vessel appears in the field of vision. If the light is now moved from a to a' , then the image will move from b to b' , the shadow from c to c' , and the image of the vessel from d to d' , thus performing the same movement as the light. We do not, however generally perceive these retinal vessels, because usually the light falls upon the retina from all points of the pupil, and therefore no distinct shadow can be produced. In the experiment just described the light proceeds from a single point only, b , and produces a distinct shadow. Moreover, the light is an unusual one, and throws the shadows upon places which are not accustomed to receive it. This latter circumstance seems to be of some importance, for if the light is held perfectly still, the figure gradually fades away, because the sensitiveness of the parts of the retina upon which the shadow is becomes blunted; it appears again, however, if the light is moved from side to side, so that the position of the shadow is changed.

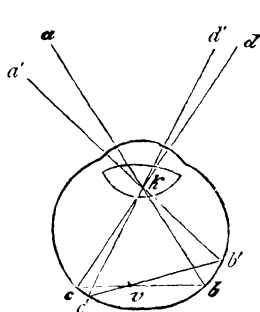

Fig. 20.

A considerable amount of light penetrates the eye through the pupil, which is quite sufficient for the representation of the external world, but none of this light seems to be reflected. The pupil of the eye generally has a dark appearance, so that we cannot see further into the eye than the iris. It is, however, possible to illuminate the eye in such a manner, that all the parts of the retina may be seen. This was first done in a satis-

factory manner by the celebrated physicist Helmholtz, the discoverer of the Ophthalmoscope. Before describing this apparatus and its functions, we must discuss the fact of the dark appearance generally presented by the pupil.

The amount of light reflected by the background of the pupil cannot, of course, be very great ; for the retina alone is able to reflect light, and as it is very transparent, and has, moreover, a dark layer of pigment immediately behind it, which absorbs all the light that has penetrated to it, the reflection must necessarily be weak. We know how difficult it is to see through a window into a room from the street. This is due to the small amount of light which comes through the window in comparison to that which penetrates the eye from without, so that the eye is not sufficiently sensitive to perceive the weaker impression ; moreover, the reflection from the panes of glass considerably increases the difficulty of perceiving objects in the interior of the room. If, however, the room is lighted up at night, we can see the interior very distinctly from the outside, although the illumination of the interior is weaker than it was in the day-time.

These circumstances also apply to the eye ; but there is another circumstance which adds to the difficulty of examining the interior of the eye. The same fact makes it impossible to see the background of a camera obscura through the lens, even when it is white. According to the laws of refraction, both the incident and emergent rays in the eye, or in a camera obscura, have a fixed direction. whilst the light which proceeds from a room through the window is diffused, that is to say

emits rays in all directions. Let us suppose an image of a lighted candle to be thrown upon the retina, then, as far as the refracting media of the eye are concerned, this image may be regarded as a second object, the rays from which will take an outward, and therefore opposite direction. Now this will be precisely the same as the path of the incident rays; for if, at the point where an image of an object has been formed by a lens, we place an exactly similar object instead of the image, then an image will be formed in the exact position of the first object, and of equal size. We see from this experiment therefore, that the rays of light, which are emitted by an image formed upon the retina, must return to the object from which they originally proceeded.

If, therefore, a light is placed before any eye which we wish to examine, the rays will all be reflected by the

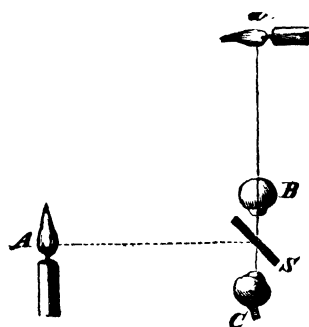

Fig. 21.

eye into the light, and we are unable to intercept them by our own eye, because we should hide the light by placing ourselves between it and the eye under examination. By means, however, of a transparent plate of glass, this obstacle may be overcome, and the eye examined when illuminated, in the manner represented in

fig. 21. C is the eye under observation, B the observer's eye, and the plate of glass S forms an angle of 45° with the line between the two eyes. The rays emitted by the lighted candle A strike the glass plate S, and are partly

reflected into the eye, which they illuminate. The rays reflected by the eye C, again strike the glass plate, which some of them penetrate, and pass into the eye of the observer, and the remainder return to the light A. The pupil of the eye C, may now be seen brightly illuminated, and even the illuminated retina can be seen more or less distinctly. The rays emitted by the image formed upon the retina, which pass through the glass plate, would form an image at a , which is at the same distance from the glass plate as A. The rays are, however, intercepted by the observer B, who is thus enabled to examine a part of the retina.

In fact, a piece of window-glass placed in an oblique position, as described above, is the simplest form of an ophthalmoscope, and may easily be arranged by anyone who wishes to make the experiment for himself. An ordinary piece of glass is sufficient for the purpose, if placed in the same position, relatively to the eye under observation and the light, as that shown in the figure. It is well to place a screen between the light and the person under observation, to prevent any annoyance arising from the intensity of the light. The observer must then place himself close in front of the person whose eye is under observation, hold the glass in the manner described, and move it about till the reflection of the light falls upon the eye. The illuminated pupil will then be seen through the glass, and appear of a reddish colour.

But, in order to see the separate parts of the retina distinctly, it is necessary to make use of lenses adjusted to the sight of the observer, and the refractive power of the eye under observation; and the result of such a

combination is a perfect ophthalmoscope. The glass, again, has been replaced with advantage by a mirror, generally a concave mirror, with an aperture in the centre, through which the observer looks. Fig. 22 shows the method of using this apparatus constructed after Ructe's plan. The light is placed near the person under observation, *A*. The rays emitted fall upon the

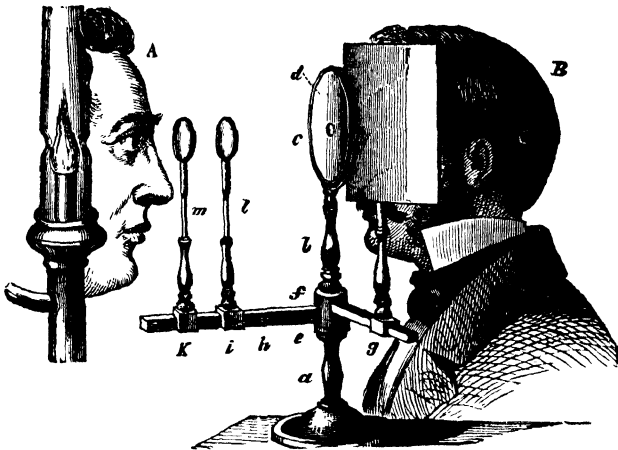

Fig. 22.

concave mirror *d*, which reflects them into the eye under observation. The observer *B*, looks through the aperture in the concave mirror, and moves the two lenses *m* and *l* till they are in such a position that a distinct image of the retina appears.

We are now in a position, with the aid of the ophthalmoscope, to make a thorough examination of the retina. Fig. 23 gives a tolerable representation of all that we are

able to distinguish of the image. The background of the whole is of a dull red, whilst the point where the optic nerve enters is distinguished as a round, bright spot, and we may see rising out of its midst the retinal vessels, arteries *a*, and veins *b*, which extend over the entire retina. The yellow spot also, the point of most

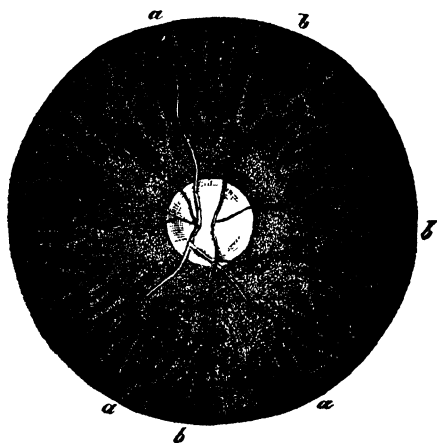

Fig. 23.

distinct vision, may be distinguished as a small bright spot.

The ophthalmoscope has become an instrument of incalculable value to the oculist. Many changes in the retina and interior of the eye, which are due to disease, can be observed and examined by means of the ophthalmoscope ; and, in fact, the medical treatment of the eye has made an immense advance since the discovery of this instrument.

The eyes of many animals, those of cats, for instance, exhibit a peculiar brilliancy, which is particularly remarkable in the dusk. It was formerly thought that the eyes of such animals emitted light independently, as it was also thought that light could be emitted by the human eye, under the influence of passion. This brilliancy, however, in the eyes of these animals is caused by a carpet of glittering fibres, called the *tapetum*, which lies behind the retina, and is a powerful reflector. In perfect darkness no light is observed in their eyes, a fact which has been established by very careful experiments ; but, nevertheless, a very small amount of light is sufficient to produce the luminous appearance in them.

CHAPTER IV.

Formation of the Retina—The Blind Spot and the Yellow Spot—Position of the Perception of Vision in the Retina.

THE retina is the nervous organ of the eye, a delicate and highly complicated apparatus, whose mechanism has hitherto been but little understood, whose formation has long been the object of laborious investigation, and is so still. Different layers can be distinguished in the retina when a fine section of it is examined with the microscope. The innermost layer, which lies next to the surface of the vitreous humour, consists of nerve-fibres, in which the optic nerve loses itself. It penetrates all the membranes of the eye at a point a little to one side of the centre, where the blood-vessels also enter the eye, which can be seen with the ophthalmoscope. At the point of entrance of the optic nerve, therefore, the retina consists only of the fibres of the optic nerve, which from this point radiate outwards. One spot, however, which lies in the centre of the retina, is free from nerve-fibres, and surrounded by them in a circular form. On account of its colour it is called the *yellow spot*. This is the part of the retina with which we see most distinctly; we will therefore speak more fully of its structure.

The layers of the retina are represented in fig. 24 as they have been described by Max Schultze. In the

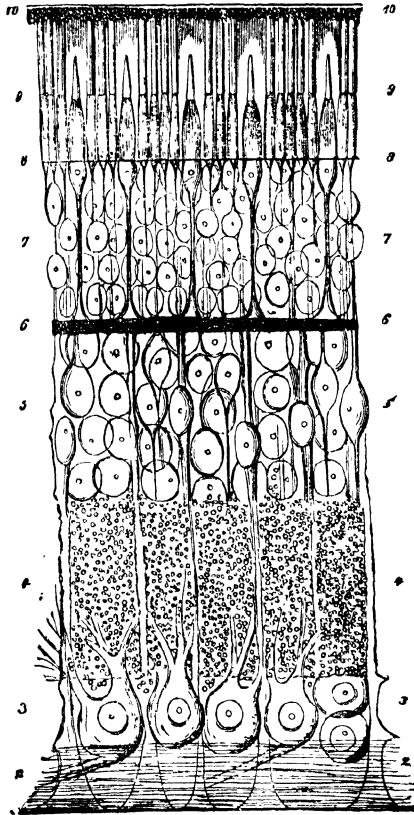

Fig. 24.

interior there is a fine *limitary membrane*, 1 ; then towards the exterior follows--the *layer of nerve-fibres*, 2 ;

the *layer of nerve-cells*, 3, which consists of cells similar to the ganglion cells of the brain; then the *granular layer*, 4, which consists of a grey indistinct mass of fine granules; then the *inner granular layer*, 5, consisting of little round grains; then the *intermediate granular layer*, 6, consisting of a fine granular mass with small fibres; then follows the *outer granular layer*, 7, which is exactly like the inner one; and ultimately after a second fine membrane, 8, is found a layer of small *Rods* and *Cones*, 9, which has a very peculiar and interesting structure. For the most part it consists of small unconnected transparent rods, which are placed close together like palisades, at right angles to the surface of the retina. From time to time a small rod is seen between them, which expands at the end, and is called a cone. These cones lie very close together only in the midst of the yellow spot, where there is a small *depression* in the retina. In the yellow spot they are very numerous, but decrease in number towards the edge of the retina.

The rod and cone layer, on account of its regular arrangement, gives us a starting point for conjectures upon the action of vision. The light which enters the eye must undoubtedly pass through all the given layers of the retina, and ultimately reach the rod and cone layer which is covered externally by the black pigment of the choroid, 10. Light can penetrate no further, since it is here absorbed by the black pigment.

The rods and cones, judging from their appearance, have all the properties which are characteristic of sensory organs. On the surface of the retina they form a continuous covering, which closely resembles a regular mosaic, and each part, therefore, of the retina seems to be

provided with a special sensitiveness, imparted by a rod

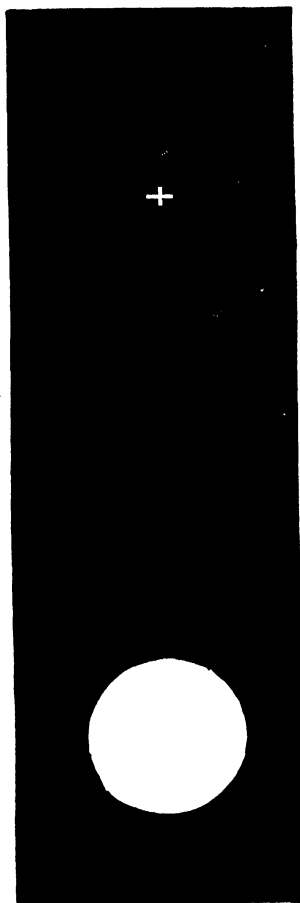

Fig. 25.

or cone, while at the same time all points are united by an intimate, and, as it were, geometrical connection. These properties agree so closely with the mathematical distinctness of our power of vision, that they immediately give rise to the conjecture, that the action of vision must take place in this mosaic-like formation. If we draw a line to the retina, from a point of the field of vision, through the centre of the eye, it falls upon either a rod or a cone, is delineated on a little square of mosaic, and is perceived by its means alone. Thus we can imagine the entire field of vision to be formed as a fine mosaic upon the retina, in the same manner as a picture worked upon a piece of tapestry.

Of the layers of the retina the light-rays strike the fibres of the optic nerve first, and from this reason we might be led to suppose

that these fibres must be sensitive. This, however, is not the case. The celebrated physicist, Mariotte, has already shown that the optic nerve, without the retina, cannot perceive a trace of light, for there is a spot on the retina which is quite blind, and it is just at this spot that the optic nerve enters (fig. 7).

Suppose in fig. 25 that we fix the right eye upon the small white cross, whilst the left is closed, and hold the book at about the distance at which a good eye is generally able to read. If, now, the book is moved slightly to and fro, then we shall find a distance at which the large white circle to the right disappears entirely. The eye must, however, always be firmly fixed upon the white cross. As soon as the eye is turned away from it in either direction, the white circle reappears.

In this experiment the white circle, under the given conditions, falls exactly upon the point where the optic nerve enters, which is situated in both eyes at a slight distance from the centre of the retina, or, in other words, the yellow spot. It is a remarkable fact that at this point we by no means perceive a hiatus in the field of vision ; but the points which are seen by the edges of the blind spot move towards each other, and so fill up the hiatus. The black ground on which the white circle lies, appears therefore quite continuous, and this would also be the case if the ground were white and the circle black. In ordinary vision, also, we perceive no dark hiatus in space, although it is easy for practised persons to perceive that objects, which fall upon the blind spot, can be forced to disappear entirely ; even the sun itself can be blotted out of the heavens, if its image is allowed to fall upon the blind spot. In all these experiments *one*

eye must be closed, since it is impossible for an object to fall upon the blind spot of both eyes at the same time.

This remarkable experiment shows us, moreover, that the fibres of the optic nerve are not excited in the smallest degree by light, and hence we may conclude that the nervous layer of the retina is also penetrated by light, without any action taking place in it.

The yellow spot of the retina presents other remarkable properties, which we will proceed to consider.

When we fix a point with the eye exactly, then the ray of light passes from this point through the middle of the pupil, and through the centre of the lens, and falls upon the retina almost at its centre, where the yellow spot is found.

In the yellow spot, therefore, the power of vision possessed by the retina is the greatest, and in it lies the depression of the retina, with which we are able to distinguish clearly a single point in the field of vision.

In reality the formation of the yellow spot explains its peculiar properties. It has already been mentioned that the fibres of the optic nerve in their expansion upon the retina, surround the yellow spot in a bow-like form, apparently for the purpose of not depriving it of any part of the light which falls upon it. This again proves that it is not necessary to our power of vision that the light should fall upon the nerve-fibres.

In the yellow spot the cones are very delicately formed, and closely packed together. We must, therefore, consider them as special elements of the sensation of light. In addition to the cones, ganglionic cells are found in the yellow spot, whilst the other layers appear thin and fine;

small • pigment-cells may also be seen, which produce the yellow colour.

If, therefore, as has been shown, the fibres of the optic nerve are not themselves sensitive to light, and the action of the light-waves takes place in the rods and cones, then a connection between the nerve-fibres and these organs appears highly probable. Towards this connection, therefore, microscopists have turned their attention for a considerable time, and later investigations have established the fact of its existence. The connection, indeed, only exists by means of very fine filaments, which penetrate all the layers of the retina, and are often difficult to detect, but which, thanks to unwearied investigation, have been observed with certainty. Fig. 26 shows how the nerve-fibre 2 is connected with the ganglion cells 3, the granules of the corneous layers 5 and 7, and lastly, with the rods and cones 9. And this is the path by which the irrita-

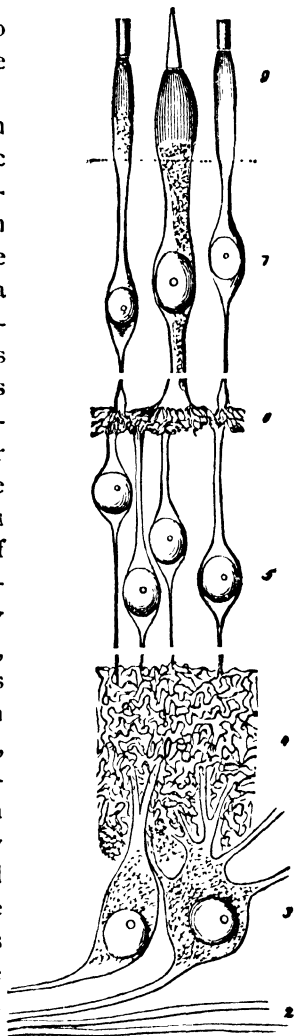

Fig. 26.

tion caused by light, which takes place in the rods, passes to the optic nerve. The optic nerve ultimately conveys it to the brain, and there awakes the sensation of light.

The trunk of the optic nerve, just like any other nerve, can be excited directly without the intervention of the retina, and by every such excitement the sensation of light is produced. If, in operations upon the eye, the optic nerve is severed, the patient has no sensation of pain, but of a brilliant flash of light, upon which follows perpetual darkness. We may also excite the optic nerve by electricity, if we pass a current through the socket of the eye and the cranium, when flashes of light are always observed in the field of vision.

Investigations in the domain of nerve physiology have led to the result, that all our nerves are merely instruments for the conveyance of one and the same action—the *irritation of the nerve*, which passes along them, in accordance with similar laws. The nerves of touch, sight, hearing, taste and smell all agree in their nature. The optic nerve no more conveys the light-waves to the brain, than the auditory nerve conveys the sound-waves. But both nerves at their terminations possess different kinds of apparatus, which are called the sensory organs, and by means of which they can be excited. The terminal apparatus of the optic nerve is the eye, or, more strictly speaking, the retina, which has the property of being excited by the light-waves, and of communicating this excitement to the optic nerve. The terminal apparatus of the auditory nerve is found within the inner ear, and by its vibration excites the auditory nerve. Now the action is identical in the two sensory organs as soon as it has reached the nerve, and carries

with it no trace of a musical sound or of a ray of light. The two actions produce in our brain, however, sensations of so different a nature, because each nerve has a special centre in the brain, where it terminates. The centre of the optic nerve has peculiar properties different from those of the centre of the auditory nerve. The first only arouses the sensation of light as soon as it is set in action, the latter only produces sensations of sound. The action of both centres is quite mechanical, and therefore they can each only produce one and the same effect. From this reason light is perceived, even if no light enters the eye, as soon as the optic nerve is torn, severed, or excited by electricity, because the optic nerve communicates its excitement to its own centre, which replies with a sensation of light. The same is the case with the auditory nerve, whose centre can only produce the sensation of sound, and never anything else. If, under accidental circumstances, the auditory nerve had been attached to the eye, and the optic nerve to the ear, then every ray of light would produce a sound, and every sound in our ear would produce an appearance of light in our imagination; we should then see a symphony, and hear a picture.

Returning to the action of the sensation of light in the retina, we may imagine it to be as follows:—

The light-waves, in a manner not yet quite understood, give rise to a process in the rods and cones of the retina which very probably consists of intermolecular motion. The rods and cones communicate this internal motion, by means of the fibrous prolongations already mentioned, to the upper layers of the retina; and thus from a particular cone, the motion reaches the nerve-fibre

with which it is connected. The motion then produces an excitement of the nerve, which excitement produces in the brain the sensation of light.

By a very ingenious calculation Heinrich Müller has shown that the rods and cones are the point where the perception of light takes place. For this purpose he makes use of the arborescent figure of Purkinje. If, for instance, the flame is moved to and fro (fig. 20), the figure moves also, as is shown by the construction. Now this figure is formed by the shadow of the vessels of the retina, and from the construction given above, the position of the shadow can be calculated in the following manner. If we measure the angle $a k a'$ round which the candle flame moves, and which is equal to the angle $b k b'$, we can find the distance $b b'$ upon the retina. Now the distance of the vessel v from $b b'$ can be determined approximately, therefore the angle $b v b'$ can also be determined, which is equal to the angle $c v c'$. Now c and c' are the shadows of the vessel, which apparently moves in the field of vision from d to d' . We, therefore, measure by observation the angle $d k d'$, which is equal to $c k c'$, calculate from it the line $c c'$, since we know $k c$, and now, in the small triangle $c v c'$, which may be regarded as an isosceles triangle, we know the base $c c'$ and the angle $c v c'$. This gives us the distance of the vessel v from the point where its shadow falls; and, in fact, we find that the shadow falls exactly upon the rod and cone layer.

Now, what is the nature of the action of light upon the rod and upon the shadow? With our present knowledge of the properties of light, we can imagine some possible answers. For instance, the action may be a

chemical one. This conjecture is most probable, because we know that light, by the chemical decomposition of iodide, or chloride of silver, can produce a picture on a photographic plate. We may, therefore, suppose that in the rods and cones a substance is also present, which undergoes chemical change by the action of light, and that, at the same time, a real substantial picture is formed upon the retina. Of course, this picture would not be a permanent one like that of a photograph, for it disappears as soon as the light ceases to fall upon the eye, and we must suppose that the nutritive action, or circulation of the blood, always destroys it. Such a chemical picture would be able to excite the terminations of the optic nerve, for we know that nerves can be excited by chemical agencies. Still, all this is mere conjecture, and similarly with the possibility that the action of light on the retina may be due to electrical action, which we know takes place in nerves and muscles. In short, it still remains a problem for science to solve, what it is which gives the rods and cones the remarkable property of exciting the optic nerve by means of light.

CHAPTER V.

The Colours of the Spectrum—Combination of Colours—The Three Primary Colours—Colour-blindness

THE light which we perceive in nature is by no means of the same kind, but we distinguish a number of kinds of light which we term *colours*. All objects possess a certain colour, due either to the light which they reflect, or which they transmit. We speak, therefore, ordinarily of coloured light, although physics tells us that colour cannot be separated from light, as if it were like a colour which an artist lays on a picture. The kind of light which we call *white*, can be decomposed, by the prism, into a number of colours, which comprise all the simple colours, and which, when combined, produce all the colours which occur in nature. If a sunbeam is allowed to fall upon a prism, as is shown in fig. 27, the beam is decomposed into a number of colours, whose sum is called a *spectrum*.

A ray falls through the opening *b*, upon the prism *s*. If the ray continued without interruption, a bright circle *d*, would fall upon the opposite wall. By refraction, however, the ray is turned aside, and since the coloured rays which it contains possess different degrees of refrangibi-

lity, a coloured stripe $r v$ —a spectrum—is formed, in which the red, the least refrangible, is found at r , and the violet, the most refrangible, at v . Fig. 28 contains the

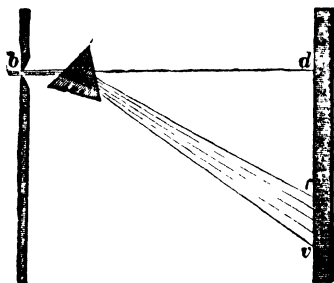

Fig. 27.

colours of the spectrum in their order. The spectrum also contains dark stripes, Fraunhofer's lines, which are peculiar to sunlight, and are caused by the absorption of light by the gases present in the outer layer of the sun. The spectrum commences with *red*, which gradually



Fig. 28.

changes into *orange*; then follows a smaller stripe of pure *yellow* at the line D, and then *green* at E. The *blue* which follows is of considerable extent, and we, therefore, distinguish *blue* at the line F, and *indigo* at G. The spectrum finally terminates with *violet*.

The colours in the spectrum are not sharply separated, but pass gradually into each other. We can distinguish as quite pure colours, red, yellow, green, blue, violet, each of which produces a sensation entirely

different to the others. The nearer, however, two colours are situated in the spectrum the greater relation they seem to bear to one another. Thus the red seems to be more nearly related to the yellow than to the green or blue; and the impression which yellow and green produce is more similar than that produced by yellow and blue, or violet. A direct change, however gradual, from red to green, would seem to us unnatural, whilst the intervening yellow offers a natural connection between the two colours.

Physics teach us that the rays of a spectrum consist of light-vibrations with different wave-lengths, which diminish from the red to the violet. Since the different kinds of light are transmitted with equal velocity, violet makes more vibrations in the same length of time than red light; the former about 667 billions, the latter 456 billions in a second. We learn, further, that all the light-rays of a spectrum differ solely in the wave-lengths of their vibrations, and possess no other special mark of distinction, nothing which has the slightest resemblance to the colour we perceive in them. Imagine the propagation of long and short waves upon the surface of water; this phenomenon will be somewhat analagous to what occurs in the red and violet rays. Water-waves of different lengths, however, are quite similar in regard to the impression which they make on our eyes, whilst the light-waves, on penetrating the eye, cause sensations which essentially differ in kind. Thus red is widely different from green and blue.

The spectrum has no defined limit at either end, but passes gradually into black, the transition being more gradual at the violet than at the red end. Nevertheless

physical and chemical action is still present beyond these visible boundaries. The invisible, or ultra-red portion, gives evidence of considerable heat, which in this part of the spectrum reaches its maximum, and gradually diminishes in the visible part. The violet end has the power of exerting strong chemical action upon certain compounds, such as iodide and chloride of silver; therefore a photographic spectrum extends considerably beyond the violet. It has, however, been shown by Helmholtz, that, under certain conditions, we can also perceive the ultra-violet end of the spectrum with the eye. If we separate the ultra-violet part of a spectrum, thrown on a screen in a darkened room, by allowing it to pass through a slit in the screen, and if it is then allowed to pass a second time through a prism, which purifies it from all strange rays by refraction, it produces upon the eye the sensation of a glimmer of light, which has a lavender grey colour.

The eye, as is well known, is only to a certain extent sensitive to light-vibrations. Physicists conclude that all the rays in the spectrum, visible as well as invisible, which are situated beyond the red and violet, consist of vibrations of the ether, which differ only in their wave-lengths, and are otherwise quite similar in form; of their vibrations, however, only those of intermediate length act upon the retina, while it is insensible to the vibrations of the ether of greater or less wave-lengths. What we, therefore, distinguish as light and colour arises from a subjective property of the retina, inasmuch as it only reacts on certain ether-vibrations. We might, therefore, imagine the existence of eyes, which could not perceive the inter-

mediate parts of the spectrum, as ours can, but only the rays situated at the invisible ends. To such eyes the world would have quite a different aspect.

All the colours which are found in nature or are prepared artificially, simple or compound, can be composed from the colours of the spectrum. Further, white is formed by the combination of all the colours of the spectrum, in the proportion in which they occur in the spectrum. The constituents, therefore, of all the light which the eye can see are contained in the spectrum.

In order to discover what impression the mixture of colours would have on the eye, it was formerly thought sufficient to mix together colouring matters, such as are used in painting, or coloured liquids. It was, however, an error to suppose that by this means the true mixture of colour was obtained; that is to say, the same colour which our eye would perceive, if the two simple colours acted upon it simultaneously. If, for instance, we mix together a blue and yellow powder, we obtain green. We should, however, never produce a green if we mixed together blue and yellow light-rays. The cause of this difference is the following. A colour, such as is used in painting, consists of minute particles, which are transparent, inasmuch as they transmit a certain coloured kind of light, and absorb the remainder. If we now consider light falling upon a greater number of particles, then a small part of it, consisting of white light, is reflected from the surface; the greater part, however, penetrates the outer layer, and is reflected from the surface of particles which are situated at a greater depth. This light is coloured, *i.e.* the residue of the white light is absorbed. A yellow powder, therefore, absorbs all the rays with

the exception of the yellow ; yet this is not absolutely the case, for rays which are situated near the yellow, among others some green, are transmitted also.

The case is the same with the blue powder. It also transmits some green, as well as blue, rays, and absorbs the rest. Now mix the small blue and yellow particles together. The blue rays will be absorbed by the yellow, and the yellow rays by the blue colouring matter, so that the blue and yellow almost disappear in the mixture of the colours, and only the green remains, which is reflected, since it is transmitted to a considerable extent by both bodies. The action would be exactly the same if we looked through a blue and a yellow glass placed side by side. The colour seen is green, for the blue glass only transmits blue and some green, but no yellow, while the yellow absorbs the blue completely, and only transmits green.

The phenomena, are, however, entirely different, if we allow two colours to act on the eye simultaneously, which may be done in the following manner. A spectrum is thrown upon a screen in which two slits are made ; through these two slits two rays of simple colours pass, and can be united by a lens. This is the most perfect method of combining colours.

An easier method of combining colours is the Colour Top.

This instrument consists of a disc, which can be made to rotate round a vertical axis, as represented in fig. 29. One hand holds a handle, which supports the upper end of the axis, and the other forcibly draws off a string which is wound round the axis, thus setting the top in rapid rotation. On the top a paper disc has been

fixed, sections of which, as may be seen from the figure, have been painted with the colours which are to be combined. The images of the colours are so rapidly super-

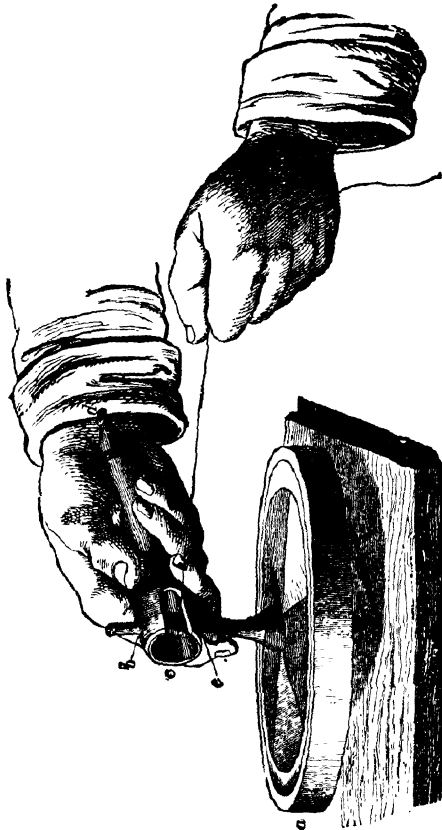

Fig. 29.

posed upon the retina, that the impression produced by the colours on the mind, is that of a mixture. If we

have black and white sections in the disc, the result is a grey colour; and by making use of other colours, we can produce mixtures of every possible shade, which can be made darker by the addition of black.

The following is a very simple method of mixing two colours together, which can be done without any instrument. Two coloured wafers, *b* and *c* (fig. 30), are placed on the table a certain distance apart, and a small plate of glass is placed before the eye, so that the wafer *b* is seen directly through it, and at the same time a reflected

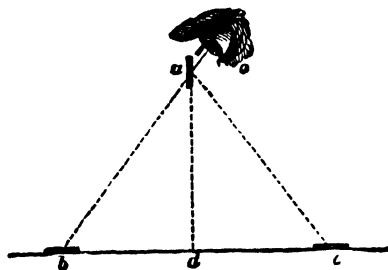

Fig. 30.

image of the wafer *c*, so that both images are superposed, and their colours combined. In this case also we produce a true mixture of colours.

Now all these methods give concordant results, although the second method rests on a different principle to the two others. In the latter the different colours were mixed objectively before they entered the eye; by the coloured top, however, the differently coloured rays were not mixed, but they only fell upon the retina in very rapid succession, the combination of the colours thus taking place on the retina. This, however, shows us

that a mixture of colours does not produce a 'special excitement on the retina, but one composed of the excitements, which each colour creates independently.

If, now, all the colours of the spectrum are reproduced upon the colour top with the greatest possible exactness, and in the proportion of their brightness, then their mixture will reproduce white, which, on account of the imperfect clearness of the colours employed, will have more or less of a grey tinge. Exactly the same grey, however, can be produced on a colour top, by the combination of black and white; and since black is nothing more than the absence of light, the combination of the colours corresponds exactly to the white which is contained in this grey.

The combination of two simple colours of the spectrum has produced a very remarkable result. It has been found that there are several pairs of colours the combination of which produces white. We include amongst them yellow and indigo, though a mixture of two colouring matters of this tint would produce green. Such pairs are called *complementary colours*, and besides yellow and indigo, *red* and *greenish-blue*, *orange* and *blue*, *greenish-yellow* and *violet* are complementary colours.

Now if we look for these complementary colours in the spectrum, we find that two complementary colours always lie a certain distance apart. Two adjoining colours can never be complementary, neither can the two ends of the spectrum, red and violet, the combination of which produces purple. It seems, moreover, that one of the complementary colours must always be situated somewhere near green, as greenish-blue, sky-blue,

yellow and greenish-yellow. On the other hand, pure green, as it appears in the spectrum, has no simple complementary colour, and it is necessary to mix with the green two colours, red and violet, to produce the sensation of white light. These three colours, *red*, *green* and *violet*, are now received as primary colours, because they are the only three *pure* colours in the spectrum which, when combined, produce a nearly perfect white.

We will now proceed to determine what influence is to be ascribed to these three primary colours in the action of the sensation of colour.

The vast number of colours and shades of colour which we meet with in nature have, through the discovery of the colours of the spectrum, been reduced to a certain number of simple colours. But between the simple colours of the spectrum there are a great number of transition colours, which produce many different shades. Each point of the spectrum differs in colour from the point next to it; this change being due to difference in wave-length of the light-vibrations, and therefore it seems as if the number of colours and the transitions between them, which can be seen in the spectrum, must be endless. The question has, therefore, been asked, how is it possible that the retina of the eye should be irritated in so many different ways, for each colour must produce a particular irritation?

To consider this question more closely, we must return to our conceptions of the physiology of the nerves. We know that the irritation of light takes place in the rods and cones of the retina, and that they transmit the irritation to the fibres of the optic nerve. If, for example, a ray of light falls upon a cone, then some kind of irri-

tation must take place in the fibre which is in connection with the cone, to provide us with some means of deciding that we have to do with red light, else the brain would be unable to recognise the sensation of red. When a blue ray of light falls upon the cones, the process of irritation must clearly be of a different kind in the same nerve-fibre, so as to inform the brain that the light causing the irritation is blue. With green light the process in the nerve-fibre must again be different ; in short, we must assume that in one and the same nerve-fibre, the irritation produced by each colour is special and different in kind.

This result is, however, directly at variance with our conception of the process of the irritation of the nerves. According to this conception all nerves were the same in their nature, and in the action of their irritation. It is possible to join together a sensory nerve and a motory nerve, so as to form one nerve, and in this case an irritation of the sensory nerve is directly transmitted to the motory nerve, and causes a contraction of the muscles belonging to it. In both kinds of nerves the process is the same, and if the irritation of a motory nerve during life produces motion only, and that of a sensory nerve sensation only, the sole reason is that the former is connected with the muscles, the latter with the centre of sensation in the brain, producing in this complicated organ different kinds of phenomena. We have already learnt that the optic nerve differs in no respect from the other nerves of the body. If it were possible, we might place any motory nerve between the eye and the brain, and the perception of light would not be destroyed in the least. The irritation of such a nerve would only

produce a sensation of light in the brain, because the central organ of this nerve, when irritated, never produces any other sensation in the brain than that of light. If, now, the action is exactly the same in the optic nerve as in all other kinds of nerves, how is it possible that, in the same nerve-fibre, red light should give rise to a different action to blue, and green light different again to yellow?

There is only one way of getting out of this difficulty, namely, accepting as a fact that every sensitive element of the retina is connected with several nerve-fibres, each of which is sensitive to a particular colour. Let us suppose, for example, a nerve-fibre to terminate in a cone, which, through its physical or chemical constitution, is only affected by red rays; then this nerve-fibre will transmit the irritation to the brain, and the brain thus receives an intimation that the impression has been made by a certain kind of light, which it recognises as red. Let us also suppose the same cone to be connected with another nerve-fibre, the end of which can only be irritated by a green ray, then the brain, if the irritation of this nerve-fibre has been conveyed to it, becomes conscious of the presence of a different kind of light, which, from experience, it will call green. We can thus picture to ourselves the existence of several kinds of nerve-fibres in the optic nerve, which differ from each other only in their terminal organs within the rods and cones, each of which can be irritated by a particular kind of light alone. At first it would be supposed that a vast number of fibres must exist in a sensitive element of the retina. It would be a great temptation to claim for every colour in the spectrum a separate nerve-fibre; but it is quite sufficient

if we reduce the number of fibres to three, in accordance with the number of primary colours, red, green, violet. In fact, all the phenomena of the sensation of colour may be perfectly explained on the supposition that, in each point of the retina, three kinds of nerve-fibres terminate, one of which is sensitive to *red*, another to *green*, and the third to *violet*.

Exactly as white light is produced by the combination of red, green and violet, all other shades of colours may be formed by the combination of these primary colours. If white light falls upon the retina, then all three kinds of fibres, those sensitive to red, green and violet, are irritated, and this simultaneous irritation produces the sensation of white. If the retina is illuminated by red light, then the fibre sensitive to red is irritated most strongly. It is, however, very probable that the two other kinds of fibres are irritated at the same time, though in a less degree; first, the fibre sensitive to green, because green lies nearer to the red in the spectrum, and then that sensitive to violet.

According to this theory, *yellow* light irritates equally the fibres sensitive to red and to green, and only slightly that sensitive to violet. Yellow, therefore, is not a primary colour, but, physiologically speaking, a compound colour; because it is due to a combination of the sensations of red and green.

Green light irritates principally the fibres sensitive to green, and very slightly those sensitive to red and violet.

Blue light irritates simultaneously the fibres sensitive to green and violet in an equal degree, and very slightly those sensitive to red. Blue, therefore, physiologically considered, is also a compound colour.

Violet light irritates very strongly the fibres sensitive to violet, and the other two only slightly.

This theory of the perception of colours was first put forward by Thomas Young, and has more lately been developed by Helmholtz. In accordance with this theory, the action of the spectrum colours upon the retina has been illustrated by Helmholtz by the accompanying fig. 31.

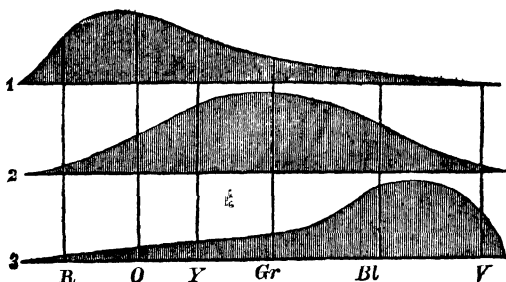

Fig. 31.

The horizontal lines, 1, 2, 3, represent the three kinds of nerves:—1, the fibre sensitive to red; 2, to green; 3, to violet. The letters under the line 3 correspond to the colours of the spectrum in their natural order, red, orange, yellow, green, blue, violet. A curve is described above each line, showing the strength of the irritation exercised by all the colours of the spectrum upon each kind of nerve. Curve 1 attains its greatest elevation between red and orange; curve 2, at green; curve 3, between blue and violet. If, now, we draw a perpendicular line through the three curves from each colour of the spectrum, then the perpendicular section of the curves will show us the relative strength of the irritation of the

nerves. We see that yellow exercises a moderately strong irritation upon 1 and 2; green irritates 2 strongly, and 1 and 3 only slightly; blue again produces an irritation of medium strength upon 2 and 3; and violet irritates 3 almost exclusively.

A very interesting observation has proved the fact, that in the retina there must be particular elements sensitive to red. Thus it can readily be proved, that the outer edges of the retina are insensitive to red. If we take a red body, for instance a stick of red sealing-wax, in the hand, and move it to one side beyond the field of vision, looking straight before us all the time – if we now move it slowly forwards till it is just distinguishable on the edge of the field of vision, it will no longer appear red but black, and the red colour suddenly reappears if we move it forward. This is not the case with blue, which is perfectly distinguishable at the edge of the field of vision.

The retina, at its edges, is, therefore, blind to the colour red, a fact most simply explained by supposing that the fibres sensitive to red are here wanting. Since these parts of the retina are perfectly sensitive to blue, they are not devoid of the fibres which are apportioned to the other parts of the retina for the sensation of colour. If there were but one nerve-fibre for the transmission of all sensation of colour, it is incomprehensible why it should not be sensitive to red at the edge of the retina. It follows, therefore, that there must be particular nerve-fibres for the sensation of red.

This peculiarity of the edge of the retina in the normal eye passes, in the eyes of many, into red-blindness. That is to say, there are a great many persons, almost one in twenty, who are incapable of distinguish-

ing red colours distinctly. They know, indeed, from ordinary conversation, that a certain colour is called red and by experience are enabled to use this expression. They call blood red, because they know it is generally called so, and other objects in the same manner ; so that it often happens that they themselves are unconscious of their imperfect sensation of colour. But sooner or later an occasion arises which shows their inability to select a red object from similar objects differently coloured. They confuse especially red with dark green and yellow. If, now, a spectrum is shown to people suffering from this red-blindness, they will distinguish two principal colours, which they will call blue and yellow. They imagine that the spectrum is shortened, especially at the red end, and the extreme red they do not see at all.

This peculiarity may be explained by supposing that in such persons the nerve-fibres sensitive to red are either wanting or insensible to irritation. The world must appear to them quite differently coloured to what it appears to us. What looks to us white, must to them have a greenish-blue appearance, because red is wanting in it, and yet they call it white, because it comprehends the whole of their series of colours. There are, moreover, many degrees of red-blindness, so that sensitiveness to red is present in a greater or less degree.

This fact is a proof that red is one of the primary colours, since it can be wanting altogether, and it is also a substantial confirmation of the theory of Young and Helmholtz, according to which these three primary colours have special nerve-fibres in each point of the retina.

CHAPTER VI.

Incidental Images—The Phantascope—Positive and Negative Incidental Images—Incidental Colours—Harmony of Colours.

IN ordinary vision a picture disappears as soon as the object seen is withdrawn, or it has ceased to be illuminated. In some well-known phenomena, however, it may be observed that the impression of light lasts for an appreciable time after the light is withdrawn. If a burning stick is whirled quickly round in a circle, we have the impression, not of a point, but of a fiery circle. Similarly, a rising rocket and a falling star produce the impression of a line of light. Moreover, if, in the night, the darkness is illuminated by a flash of lightning, we always have the impression that the flash has lasted for some time; although, in reality, it is of such momentary duration, that if a railway train, as it rushes by, were illuminated by lightning it would appear to be standing still. The persistence of these impressions is unpleasant if we have looked at a powerful light or the sun. We then perceive spots of light for some time, even when the eyes are closed, which greatly inconvenience our sight.

These prolonged impressions of light are called

incidental images. These images may be observed of all bodies, which are not too feebly illuminated, if the eye is sufficiently sensitive; especially of a bright window, when the eyes are opened and closed rapidly. After a few seconds a faint image of a window is observed, which gradually disappears. The existence of incidental images has already been pre-supposed in the mention of the rotating disc, which contained black and white, or coloured sections. If the rotation is sufficiently rapid we no longer perceive the single sections, but a combination of their colours. We have here to do with the phenomenon of incidental images, for the image of the black section is superposed upon the image of the white one with such rapidity, that the incidental image of the black section has not yet disappeared; the images, therefore, of the black and white sections are mentally combined, and the result is a grey. The revolutions must, therefore, be made with a certain velocity, for the grey colour appears when white follows black about thirty times in a second. If the revolution is less rapid it produces a flickering between the black and white, which produces an unpleasant and fatiguing impression upon the eye. This sensation is still more troublesome with a flickering light, since as the light diminishes the eye each time has a short rest, and is irritated with increased vigour by the light when it breaks out again.

The persistence of these incidental images is the basis of a well-known instrument, the *phantoscope*, or magic disc, on which various figures are seen in motion, such as dancers, horsemen, gymnasts, etc. Fig. 32 explains this phenomenon by a simple example. Upon

a disc a pendulum is represented in different positions of its oscillation. If we look, from the other side, through the holes 1—12 upon a mirror, and turn the disc with

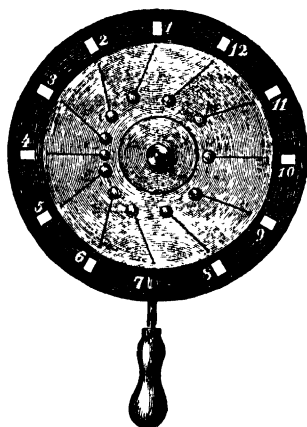

Fig 32.

tolerable rapidity, the pendulum is seen first in the position of 1, then in 2, 3, etc. The images follow each other very rapidly, so that the pendulum appears to have made an oscillation. Here the incidental image of one pendulum remains a sufficient length of time for the image of the next to take its place.

From the kind of incidental images we have just considered, must be distinguished those which are formed when we look for a long time at a bright object. Look, for instance, through a window at the bright sky for from half to a whole minute, without moving the eyes, so that the window frame may be depicted upon a definite part of the retina, and then turn the eyes quickly towards a wall, or a white sheet of paper. A dark window will now be seen with a bright frame, so that in this incidental image all the bright parts of the picture appear dark, and the dark bright. On this account it is called a *negative* incidental image, while the former kind of incidental image is called *positive*.

Negative incidental images are caused by the retina being fatigued at the spot where the light has acted

strongly upon it. The bright surface of the window will have excited the retina for some time, in consequence of which a definite portion of it will be fatigued, whilst that part upon which the dark window frame was depicted will not be fatigued. If the eye is now turned upon another surface, the fatigued parts will be more feebly excited by this surface than the rest, and consequently a dark window with a bright frame will appear.

A similar experiment may be very well performed in the following manner. A small square of black paper is placed upon white paper, and the eye fixed upon it for some time. If the eye is now suddenly turned upon the white surface of the paper, a bright square is seen upon it which moves about with the eye, and after some time gradually fades away. It is characteristic of this phenomenon that it follows the direction of the eye, and thus proves that we have not to do with a reality, but with an optical illusion, caused by an action within the eye. The most curious part of it is that we, nevertheless, imagine its cause to be external to ourselves, since we have been unconsciously taught so by experience.

Negative incidental images can, however, be perceived with closed eyes. If we close the eyes after looking at a bright object we perceive the same object in a darker tint. This fact seemed for a long time inexplicable, and at variance with the theory of incidental images mentioned above. The instructive investigations, however, of Purkinje, at the commencement of this century; had already shown that, for our eyes, absolute darkness did not exist. In the densest dark-

ness, even when, in the darkest night, every trace of light is artificially excluded with the utmost care, the eye has still a perception of light of its own. The sensibility of the eye increases in this darkness in an extraordinary manner, and fantastic clouds of light pass over the field of vision, moving up and down, disappearing and reappearing. It is very probable that this is due to some internal excitement, caused by the circulation of blood in the retina.

This peculiar power of the retina remains even when the eyes are closed, apart from the diffused light which penetrates the eyelids in the day-time, and the negative incidental images which are seen with closed eyes are sufficiently explained by supposing that the fatigued parts of the retina are less sensitive to this feeble sensation of light.

The incidental colours also, which are formed in the eye, are most interesting. It is well known that there are combinations of colour which are pleasant to the eye, and some which are unpleasant or even ugly. Pleasant combinations are blue and yellow, red and green in all shades ; while green and blue, yellow and green, and their accompanying shades, are distasteful. We speak therefore of harmonious and unharmonious colours, thus drawing a comparison from music.

If, with reference to this point, we consider the position of colours in the spectrum, we find that harmonious colours are nearly complementary colours, whilst unharmonious colours are situated in the spectrum more or less near to each other.

This does not, however, scientifically explain the cause of the harmonious or unharmonious relation

between colours, which is first satisfactorily explained by the following experiment.

If we look for a long time at a green surface and then direct the eye upon a white one, it appears for some moments to be of a red colour. This observation occurs with tolerable frequency in ordinary life. In order to give it a scientific form, lay a small square of green paper upon a sheet of white paper, and look at it very closely for some time with one eye. Then look at the white paper, and a red square is seen upon it, which follows the direction of the eye and gradually fades away.

Now what is the cause of this incidental colour? The following is the simple explanation: green light does not excite all the elements of the retina which are sensitive to light, but only those sensitive to green, and by looking for a long time at the green paper these have become fatigued. If we then look at the white surface, this excites all the sensitive elements of the retina; the fatigued parts are least excited, so that the complementary colour appears in which the red predominates.

Incidental colours are always seen in complementary colours. If we had been looking at a red paper, then the white surface would look green; the action of blue produces a yellow incidental image, and *vice versa*. In short, the colour which is seen, and the incidental colour, are always of such a kind, that conjointly, they produce white.

These facts give important support to the theory of colours just mentioned. They explain why red should excite the nerves sensitive to red more readily than the rest, and green and violet the nerves corresponding to

them, and why the excitement of all three together should produce white.

The following is an observation which belongs to this part of the subject and which is frequently made in ordinary life. If we gaze for a moment at the sun, very strong incidental images appear which last for some time. They are always coloured and frequently change their colour. This arises from the fact, that the colours of the incidental image of white sunlight do not disappear simultaneously. When one colour has faded the image is no longer white, the remaining colours appear, which gradually fade away after many variations.

Colours were very early compared to musical sounds, and we have already spoken of the harmony of colours in this sense. This comparison is, however, scientifically-satisfactory only to a certain extent. The impressions made by a mixture of colours and a chord in music are very different in character. In a chord a practised ear can hear the different notes, and separate it into its component parts. A mixture of colours, on the contrary, makes an impression as a whole, and can only be separated into simple colours by a practised eye, to a certain extent. It is impossible, however, for the eye to distinguish the primary colours in white, although we may be quite certain that it contains them; while in every combination of tones each tone can be recognised.

CHAPTER VII.

The Movements of the Eyes—Binocular Vision—Simple and Double Vision—The Identical Spots of the Retina—The Horopter.

THE eye is endowed with great mobility within its socket. Since it has a spherical shape and the hollow in which it is situated has a spherical shape also, it is evident that this gives the eye the power of turning in every possible direction. The eye, as we know from experience, can be moved with great rapidity, which enables us to direct our attention rapidly to different consecutive objects. We should appear much more clumsy, therefore, if our eyes were fixed firmly in our head, and we were always obliged to move the head from side to side.

Fig. 33¹ represents the situation of both eyes in their sockets, together with the muscles which give them their power of motion. The socket is enclosed within walls of bone, which, at the back, contract to a funnel-shaped form as far as the aperture through which the optic nerve passes. The socket is filled up with a mass of fat, in which the eye-ball is embedded as in a socket-joint. It encloses nerves, muscles and blood-vessels. The figure

¹ Helmholtz, 'Optics.'

It also shows the passage of the optic nerve (*n*) through the bony aperture (*o*), and, before its exit, the cruciform shape of the combination of both optic nerves (*m*), which

Fig. 33

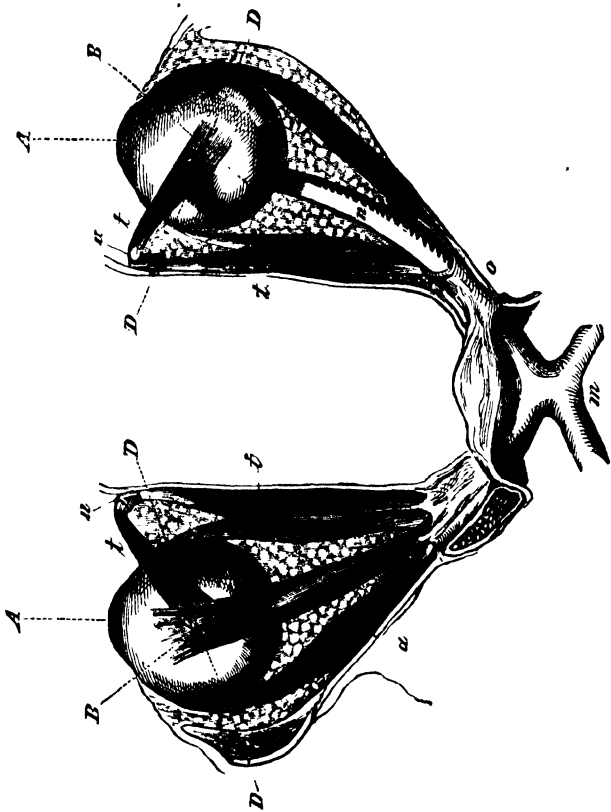

is called the *chiasma*. The muscles which are intended for moving the eye, are attached to it like the bridle to a horse's head. They almost all spring from the

osseous wall at the point where the optic nerve enters, and extend through the entire length of the socket to the eye-ball. There are four optic muscles which pass directly to the eye, of which one is situated above and one below, one on the outer and another on the inner side.

It is clear that the upper muscle directs the eye upwards, making it revolve upon the axis D, the lower one downwards, the inner one inwards, and the outer one outwards. Since, in ordinary vision, we always fix the same point with both eyes, we therefore move them simultaneously according to fixed laws. If we look upwards or downwards with both eyes, then the corresponding muscles are always brought into action. If, on the contrary, we look with both eyes to the right, the outer muscle is brought into action for the right eye, and the inner muscle for the left, and *vice versa*. If, however, we direct our eye inwards towards a near object, then the two inner optic muscles contract; if the eyes now look at a more distant object, the two outer muscles bring the direction of the eyes more nearly parallel. We are unable to turn both eyes at the same time further apart than when their axes are parallel.

Thus we see that the contractions of optic muscles are connected in many ways. The symmetrical and similarly named muscles frequently contract simultaneously, and the opposite muscles frequently have a common action. All these combinations, however, are intended to enable us to fix the eyes upon the same point, so that the optical axes, drawn from the yellow spot through the centre of the pupil, may meet in the point upon which the eyes are fixed. We are never able so to move the

eyes that the optical axes shall not meet. We cannot, for instance, look with one eye upwards and the other downwards, or with one eye to the left and the other to the right.

Besides the muscles named there are two other oblique muscles which are attached to the eyes in an oblique direction. The position of one is superior and internal (*t*) and has a very curious course. For instance, it commences at the posterior aperture through which the optic nerve enters; it does not then pass forwards directly to the eye, but through a ring, *u*, like a cord which runs over a pulley, then turns round and is attached obliquely to the upper surface of the eye-ball. The second oblique muscle is situated upon the lower side of the eye-ball, and is not shown in the figure. It commences from the inner wall in the socket, passes onwards under the eye, and is attached (at *r*) opposite to the upper oblique muscle. The two oblique muscles give the eye the power of performing movements which are impossible with the aid of direct muscles alone. It is easily seen in the figure that the oblique muscles can roll the eyes round an axis (B), which approximates to the optic axis, in opposite directions.

The various directions in which the eye can be moved by means of the combined activity of the muscles named, and the precision of the motions described, not only allows the picture of the outside world to be depicted upon definite parts of the retina, but also gives expression and life to our countenance. It is chiefly the eye which betrays in our face the state of our mind and thoughts; and this is done, for the most part, by the movement and position of the eyeball, associated with which

are, of course, the action of the facial muscles, of the eyelids, as well as the power possessed by the eye of accommodating itself to a change of circumstance. A troubled look lowers the eyes; an animated one raises them; and thus the mind, while it derives mental nourishment from without through the eye, reveals its inner actions through the same organ.

Monocular vision is incomplete. The entire field of vision is depicted on the retina as a plane surface, or like a picture, without presenting any means of distinguishing the various distances of the objects from our eye. With a single eye we only, in reality, perceive a bright surface with different lights, shadows and colours, upon which we see objects in a single plane. But practice gives us indirect means of distinguishing the distance of objects. Objects whose size we know, we should consider distant if they looked small, and near if they looked large. In monocular vision we also use the laws of perspective, from which objects gain the appearance of solidity. Again, we have to adjust our sight much more to see distinctly objects which are near, than when they are distant, and by this means we are enabled to determine their distance from us. But in reality, with one eye we still see merely a plane surface, we obtain no idea of solidity, for it is only the experience gained in life which impresses upon us the fact that we have to do with a world of space. Where this experience fails us, we not unfrequently, in monocular vision, fall into extraordinary illusions. For instance, if we are looking at the sky, and a small insect flies past, so near to one eye that it is not seen by the other, we imagine we have seen a great bird in the sky. The following experiment

can easily be made. Suspend a ring by a thread, and let some one hold it before you at a certain distance so that the thin edge only of the ring is visible. Then try to pass a small stick through the ring, and it is astonishing how difficult it is to aim correctly. If the other eye is opened, it is done with ease.

Binocular vision reveals to us the third dimension of space, enables us to look into the depths of the surrounding world. Even with a single eye, by means of the touch, and the movements we make in space, we should be able to arrive at some notion of it, but a clear, immediate view would be impossible under any circumstances.

We will proceed to consider binocular vision in its simplest relations. If we fix our gaze upon a certain point, the corner of the table opposite us, then in both eyes the corner falls upon the yellow spot of the retina, and both optical axes, when prolonged, meet in the corner of the table. Although an image of both points is formed in both eyes, yet we see a single point, and not two points. This is the first enigma which we meet with in this part of our subject:—Why do we see a single object, and not two objects, with binocular vision?

A definite answer to this question cannot yet be given, but we may say that the union of both images in one is an act of the brain. From an idea that the chiasma of the optic nerve has some influence on single sight, it has been thought that a union of the nerve-fibres takes place there. Nevertheless, this is not the case, and we must confine ourselves to the idea, that the brain is able, under certain conditions, to unite the excitements

of the two nerves, since it transfers the cause of them to the same spot in the outer world.

Thus if we fix our gaze upon the corner of the table when it is at a certain distance, the two optical axes intersect at this point and form an angle with each other, which is called the angle of convergence or the optic angle. If we now allow our gaze to move further along the edge of the table from the corner, the angle of convergence gradually diminishes. We have, of course, no means of knowing the size of this angle without scientific measurement, but we have a delicate sense of the position of the eyes by means of the muscles which move them outwards or inwards, and this sense enables us to determine the distance of the objects seen. This sense is called the *muscular sense*, which is more or less developed in all our limbs, and by means of which we measure all our movements, maintain our equilibrium when walking or standing, and which gives us much of our dexterity.

Thus, while we allow the point of intersection of the optical axes to wander over space, we become conscious of its extent, and of the distances of the objects contained in it. But this is not the only advantage which we gain from binocular vision. We have, hitherto, only spoken of the observation of the single point fixed by the eye, which is depicted upon the yellow spot of the retina. The whole retina, however, takes part in the act of vision, though with diminishing distinctness towards its edge. Thus, in our eye, all the pictures on the retina are combined in a peculiar manner, giving an appearance of solidity to the objects seen. If both eyes could only perceive the

point fixed by them, we should still be able to obtain a knowledge of the nature of a body, by allowing them to wander over its surface. This might be done perfectly, and with tolerable rapidity, though we should miss the idea of solidity, which immediately takes place in binocular vision. For if we fix our eyes as steadily as possible upon a certain point of an object, the corner of a table, for instance, we perceive the entire object at the same time, since the image of the whole table is imprinted upon the retina.

Before we enter further into the question of our perception of solidity, we must consider a property of the retina, which has hitherto only been ascribed to the yellow spot. If a point in the field of vision falls upon the yellow spot of both eyes, we then perceive a single image of it. This power of combining the visual image, however, is possessed by the entire retina, for in ordinary sight the whole field of vision presents a single, not a double appearance to us.

The parts of the retina which are able to combine the images depicted on them are called *identical* or *corresponding* points. It is easy to see the relative situation of these points. If we take a point in the field of vision to the right, this point is depicted in the right eye upon the inner half of the retina, but in the left eye, on the contrary, upon the outer half of the retina. If, therefore, it is possible to see this point as a single and not as a double one, then in the outer half of the left retina, and the inner half of the right, there must be points which mutually correspond. It is evident, therefore, that the upper and lower halves of the retinae must correspond as well as the two right and the two

left halves, for the entire upper half of the field of vision is depicted upon the lower half in both eyes, and the lower upon the upper; the left upon the right, and the right upon the left. Hence the corresponding points are found by imagining the retinae of both eyes to be superposed in their natural position. Points which coincide, correspond as the points a , b , c (fig. 34), on

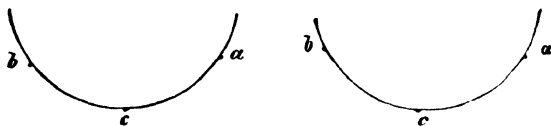

Fig. 34.

the two semicircles which represent the right and left retinae.

It can easily be shown that, in reality, we do perceive double images, if they do not fall upon corresponding parts of the retinae. If we hold a finger at some distance from the eyes, so that we can see a more distant object beyond it, the window or the lamp, for instance, then the finger will appear double as soon as we fix our eyes upon the distant object, and the latter will appear double when we fix our eyes upon the finger.

In fig. 35, both eyes are represented in the position in which they would be fixed upon the finger f , the image of which is depicted upon the yellow spot and is seen singly. On the other hand, the distant object g would appear double, for it is depicted at g^1 and g^2 , two points, one of which lies to the right and the other to the left of c , and, therefore, cannot correspond. We then

see the image of g on each side of f at G^1 and G^2 , and indistinctly as long as f is distinct. If we shut the right eye then the image G^2 on the same side disappears, if the left eye is closed G^1 disappears. The two points

on the retinae g^1 and g^2 can, under no circumstances, enable us to see a single point in the field of vision as such.

If, now, we fix the eyes upon the object g , the finger immediately appears double (fig. 36); g now falls upon the corresponding centres c , and is seen as a single point. In the right eye the image f is formed to the right of c at f^2 , and in the left to the left of c at f^1 . We transfer both images to the opposite sides at F^1 and F^2 . They fall upon points of the retinae which do not correspond, and consequently appear to us double. If we close the right eye, then the left

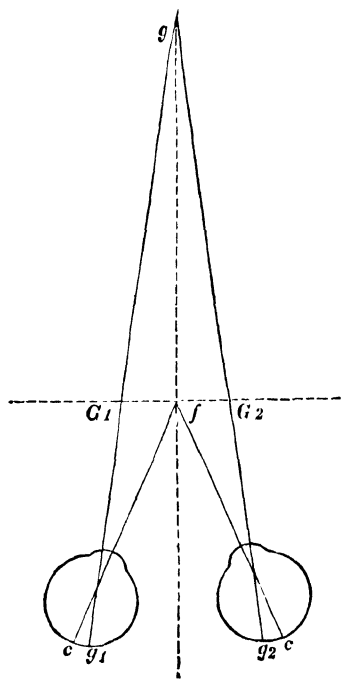

Fig. 35.

image disappears, and *vice versa*.

From the position of corresponding points in the retinae, we can find for every position of the eye, by construction, whether a point of the field of vision falls

upon corresponding points or not, whether, therefore, it will appear single or double.

There is only one case in which every point of the field of vision is seen single, and that is when it is at a very great distance. When we look, for instance, at the

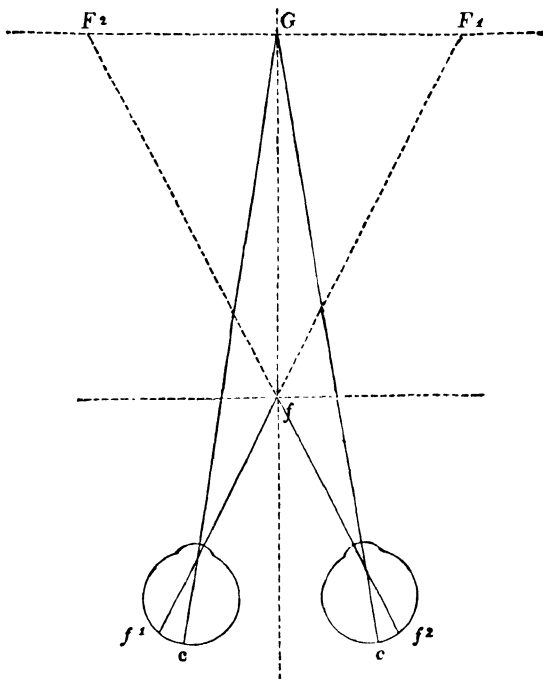

Fig. 36.

sky, which is at an immense distance from us, and fix the eyes upon a single star, then all the other stars appear single and not double.

While the two rays (1) which proceed from the star looked at are parallel to each other, the rays (2) which reach the eye from a star situated to the right are also parallel (fig. 37) and meet the retina at aa . Since these points are situated at an equal distance from, and upon the same side of,

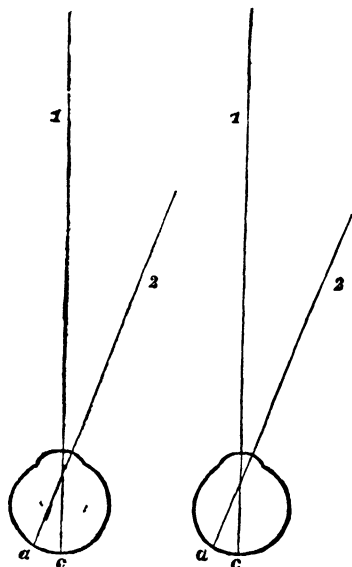

Fig. 37.

c , they cause the perception of a single image. Objects on the horizon, or distant landscapes, when seen from the top of a mountain, produce nearly the same effect, since the angle of convergence in these cases is insignificant.

As soon, however, as we direct our eyes upon near objects after viewing distant ones, then the conditions under which the visual perception is single or double become complicated. A particularly interesting case of this

kind was first accurately examined by Johannes Müller. If we (fig. 38) fix our eyes upon a point C , situated in middle distance, then the optical axes converge, and C is depicted upon the centre c . A circle is now described, which passes through C and the optic centre k of both eyes, from which it can be shown that all points in space which lie upon the circumference of this circle are seen

singly. Take a point A, and draw from it the imaginary lines $A k a$ to both eyes, meeting the retinae at a , then the angles $c k a$ in both eyes are equal, since they are equal to the angles at the circumference $A k C$. Thus, in both eyes, the point a is equidistant from c , and on the same side; hence, the point A must be seen singly.

We can convince ourselves of the truth of this by the following experiment.

Take two quill pens, and hold one in the position C, firmly before the eyes, fixing them steadily upon it. Now

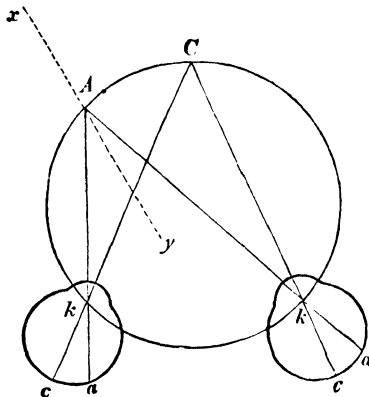

Fig. 38.

move the other pen along the line $x y$; we shall then perceive that a double image of it is seen when it is moved towards x and y , and that there is one point A at which it is seen single.

This imaginary figure in space, in which all points are seen singly, is called the *Horoptyer*, which, in the cases observed, always forms a circle. It has also been discovered

that a straight line can be drawn through the point C perpendicular to the circumference, upon which all points are seen single also.

For other positions of the eye complicated Horoptery figures have been constructed, which we will not enter into further. The only other interesting case is when we look into the distance, standing in an erect position. As Helmholtz has shown, the ground then forms our Horopter. When we think how safely we step forwards without fixing our eyes on the ground before us, this property of the eye will not appear unimportant, for we should stumble much more frequently if we fixed our eyes, when walking, upon an object at an equal height with our eyes.

CHAPTER VIII.

The perception of Solidity—The Stereoscope—The Telestereoscope—The Pseudoscope—The perception of Luminosity—The struggle between the Fields of Vision.

ALTHOUGH we can prove from experience that, in binocular vision, double images really exist, and can show that only limited portions of space can be seen single, yet we are quite unconscious of the existence of such double images in our general vision. A hasty glance round the room, or through the window upon the street, convinces us that we have seen no object double, but everything single. We have learnt, further, that we are looking into space, where objects are situated at different distances, and not upon an even surface of any kind. In binocular vision we gain an idea of space, and an impression of solidity.

The conditions under which we obtain an idea of space with binocular vision are easily discovered by a simple consideration. If, for instance, we fix the eyes upon an object in the room so that we see the wall behind it, it will then conceal from view a certain portion of the wall. The portion concealed is not, however, the same for both eyes, but it lies more to the left for the

right eye, and to the right for the left eye, and if we close quickly first one eye and then the other, the object in front of the wall will appear to move from side to side. Hence, it is evident that the images on the retinæ of both eyes cannot possibly be the same; the objects seen must appear rather to merge into each other.

The difference between the two retinal pictures of course is not determined by the will but by a definite law. Suppose that we have looked at an object from two different points of view; then we shall have received two images, which bear a strong resemblance to each other. This is the case, in a less degree, with binocular vision, for the right eye has a different point of view in the head to the left.

In a special case mentioned above, we have already made use of the law under which the displacement of objects seen takes place. As a general rule it will be found that with two objects, placed one behind the other, the nearer one is displaced by the right eye to the left, and by the left eye to the right.

With a large field of vision, filled with a number of objects, it becomes very difficult to find by construction the direction and amount of displacement for both retinal images. With a single body, however, the result is much more easily attained. Let us take, as an example, a truncated pyramid of four sides, which is viewed from above. The appearance will be similar to that represented in fig. 39 (P). If, however, we look only with the right eye, then the summit of the cone will seem to be displaced towards the left, as in r , and towards the right, as in l , if we look only with the left eye. Of course it is here supposed that the head is held perpen-

dicularly over the pyramid, so that the centre of the head is perpendicular to the centre P.

Now if we look at the pyramid with both eyes, it is clear that the image r is depicted upon the right eye, and

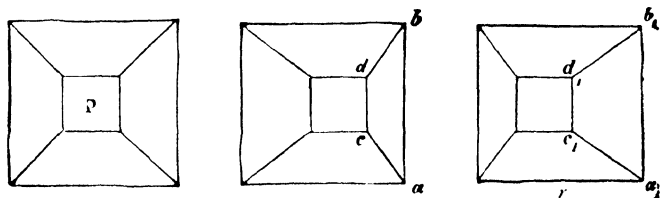

Fig. 39.

the image l upon the left. These images are different, yet experience shows us that both are combined so as to produce the impression of solidity.

The celebrated philosopher, Wheatstone, was the first to state that the perception of solidity depended upon the dissimilarity of the images depicted upon the retinae of the eyes. He constructed a *stereoscope* of a very simple kind, in which two drawings were viewed in the fol-

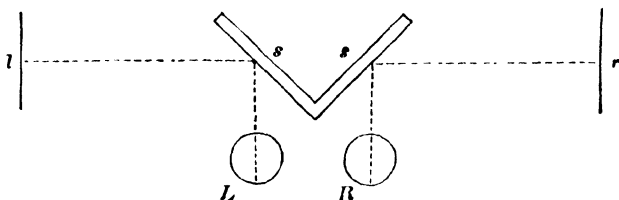

Fig. 40.

lowing manner: The two eyes, R and L (fig. 40), look at two mirrors, s and s , which are placed obliquely to the

eyes, and at right angles to each other. At r is placed a drawing, one of the pyramids for example, as it appeared to the right eye; and at l the corresponding picture as seen by the left eye. According to the laws of reflection, each eye now sees the image intended for it in the prolongation of the optical axes, where both images are combined so as to produce an image in relief. We think we see a single object simply because each eye sees the same object which it would see if the rays proceeded from a real object.

Wheatstone's stereoscope has been superseded by Brewster's, which is known to all. There is no need to describe its outward form.

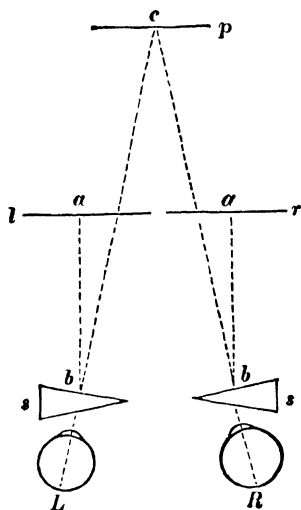

Fig. 41.

The most important part of this stereoscope consists in two lenses (fig. 41) s and s , through which the two eyes R and L look. The pictures r and l respectively correspond to the right and left eye. The ray $a b$ from the right-hand picture is refracted by the lens, so that it appears to come from c , and the same is the case with the corresponding ray for the left eye. Thus both pictures are united in the point p , where each eye seems to see its corresponding picture, and the

two pictures therefore unite to form one picture in relief.

Photography, as is well known, has been of great

service in the production of stereoscopic pictures. Two photographic cameras, instead of the eyes, will produce pictures exactly similar to those we see in reality, and this result is not only attained with single objects, but with a space filled with a great number of objects, which may be grouped entirely according to taste. The impression of relief, which the stereoscope always produces, is, therefore, very striking.

It is also possible to see stereoscopic pictures without any instrument, if the axes of the eyes are placed parallel to each other, so that the right eye is fixed upon the right picture, and the left eye upon the left. We must then look as if we wished to see a distant object through the picture. To do this, make a small hole in the centre of each picture, and hold the paper in such a position that each eye looks through the hole at one distant object. If we now try to fix both eyes upon this object, and to see it distinctly, which is easily done, we see that the two pictures have combined and produced a stereoscopic picture.

In looking through a stereoscope, we allow the eyes to wander over the field of vision just as we do when looking at ordinary objects, and the appearance of relief will be most distinct at the point of intersection of the optical axes. The eyes converge when we look at a near object, and diverge when we look at a more distant one. If, for example, we look at the bases $a b$ and $a_1 b_1$ of the pyramid (fig. 39), and then at the nearer edges $c d$ and $c_1 d_1$ the optical axis of the right eye moves from $a_1 b_1$ to $c_1 d_1$, whilst the optical axis of the left only moves over the much smaller space from $a b$ to $c d$, proving that the two axes must have converged. This accounts for the

feeling, that the object of our vision is at a greater distance from us than it was before.

This movement of the point fixed by the eyes, which is situated at the intersection of the optical axes, affords an important aid towards the determination of distance, and towards the comprehension of the objects seen in space, and evidently plays an important part in enabling us to see stereoscopic pictures. This might lead us to suppose that our perception of solidity arose from an investigation of the entire space by the rapid movements of the eyes, and from our being thus enabled to gain a knowledge of its dimensions. But, however important this fact unquestionably is it is, quite possible to see objects in relief without moving the eyes at all. We see objects in relief, for instance, during the momentary illumination caused by a flash of lightning, or by an electric spark, although the eyes have had no time to make any movement.

This has been still more clearly proved by Dove's experiments, in which stereoscopic pictures were seen under the momentary flash of the electric light. The impression of solidity was generally quite perfect within the range of distinct vision in the centre of the field, whilst as to the outlying parts of the field of vision, no decision could be made concerning them on account of their indistinctness.

It is very remarkable that in these experiments double pictures were not seen any more than in ordinary vision, although they must have been present. Double images can only be seen when we look at objects long and attentively. The former is impossible under a momentary

illumination, and our attention is otherwise occupied in ordinary vision.

From this it follows that in the perception of solidity the double images are united in a single one, not, however, through any property of the retinae, or the optic nerve, but through the will alone; for we can see the double pictures if we wish, especially if we have time to direct our attention to it. Neither is the combined image due to our neglect of the image depicted upon the right or left eye, for both are united in the imagination. Here, again, we are brought into contact with a mental act, which, as yet, we have not been able to explain physiologically. Still, we must add that this imaginative power can only be attained by experience, and that we should certainly never possess it if we had not acquired a knowledge of the dimensions of space by constant practice. This experience is chiefly acquired through the unceasing movements of the eyes.

The combination of the double images is a substantial aid towards our perception of solidity. For, since the two images are dissimilar, and we see with both eyes a larger portion of an object than we do with one eye, the object seen cannot have the appearance of a plane surface, and our experience tells us that it is a solid object.

Stereoscopic pictures have given us a closer insight into the law which governs our perception of solidity. The dissimilarity of the two pictures explained why the four-sided pyramid was seen in relief. From this it is easy to discover the appearance the picture must present if we were to look from the base into the interior of a

four-sided pyramid. We have only to change the position of the two pictures, as in fig. 42. The right eye sees the picture *r*, in which the point is displaced to the right.

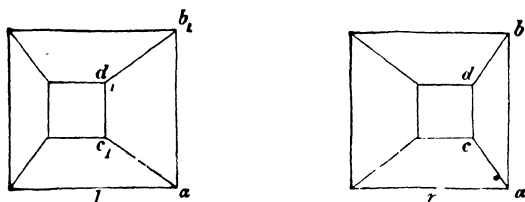

Fig. 42.

and the left eye sees the figure *l* where the displacement is towards the left. The stereoscopic impression results from our appearing to look into a hollow body.

It is precisely the same with the following figures (fig. 43). The first has the appearance of a truncated cone, the summit of which is turned towards us; the

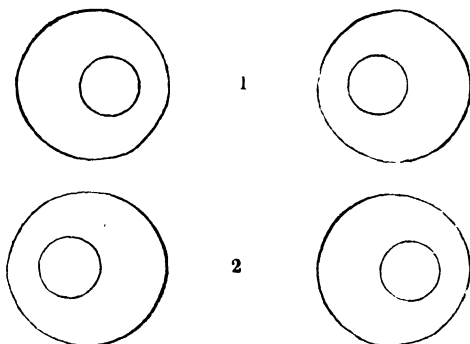

Fig. 43.

second has the appearance which such a cone would present if we looked into its interior from the base. If, by

a simple contrivance, we transfer the inner circle in such a drawing from position 1 to position 2, we can observe directly the change of the one body into the other.

From this experiment it is clear that the change of the position of any two stereoscopic pictures would always be attended with a similar result, *i.e.*, all the elevated parts would be changed into depressions, and *vice versa*. An instrument arranged so as to produce these inversions with simple bodies is called a Pseudoscope. It changes convex into concave, alto-relievo into basso-relievo. But the inversion of a complicated picture—a landscape, streets, etc., produces an impression which is perfectly bewildering. It seems as if all the objects—men, trees, etc., had been placed in a depression of the earth, and yet everything remains in its place. Therefore, the nearer objects appear very large, because we imagine them to be at a great distance, and the more distant objects smaller, because they seem to be nearer.

The action of Helmholtz's *Telestereoscope* is very interesting. By means of this instrument we obtain a stronger stereoscopic view of distant objects than we are able to do with our own eyes. Let the two eyes r and l look into two mirrors s (fig. 44), which, as in Wheatstone's stereoscope, are placed obliquely to the eye. At a little distance on either side, and almost parallel to them, are placed two other mirrors s' . The rays from a distant object fall upon these two latter mirrors, then upon the first pair, and from these reach the eye. The same effect, however, is produced as if our eyes were placed in the position of the two mirrors s' , and were, therefore, at a greater distance from each other. Let us suppose a pair of eyes to be so placed in a gigantic head,

it would at once be evident that they would be able to see a larger portion of a distant object than we do with two ordinary eyes, and this would produce a more powerful stereoscopic effect. We see from the figure, that in looking at the ball *K*, the eyes would only see the section

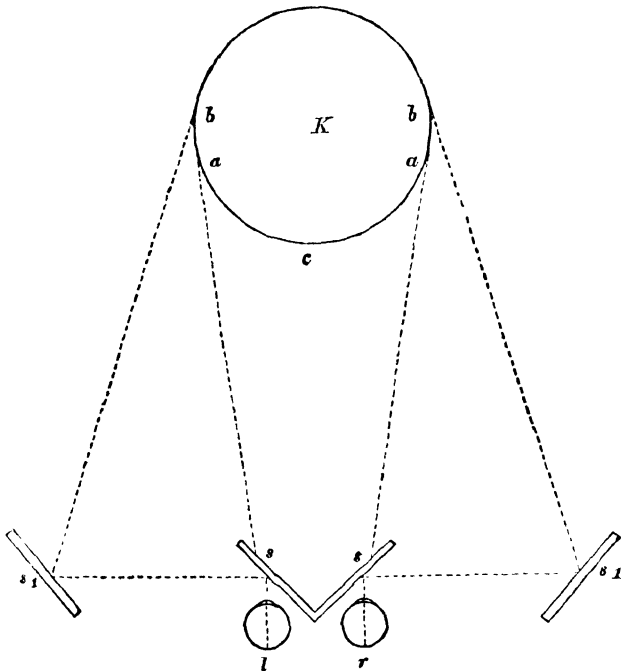

Fig. 44.

a c a, but, with the help of the instrument, they would see the larger section, *b a c a b*, because the rays from *b* are reflected by the mirror *s¹* upon the mirror *s*. Looking at a landscape in this manner it will seem to have

been brought nearer, because it is only when objects are near to us that we see so large a portion of their surface as we do by means of this instrument; and since the apparent size of the objects remains the same, the impression is produced of a model, in which the different bodies stand out in high relief.

The study of stereoscopic phenomena has also enabled us to explain luminosity. Those bodies are luminous which can reflect light, but are not perfectly smooth and level. Water, when quite smooth, reflects perfectly, but is not luminous, becoming so as soon as its surface is ruffled by ripples. Silk is luminous because each par-

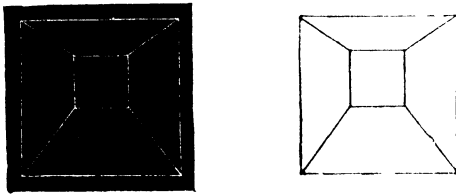

Fig. 45

ticle reflects light, though altogether they do not form a reflecting surface. Now it has been observed that if two pictures are viewed through the stereoscope, one of which is white and the other black, as in fig. 45, this gives rise to an impression of luminosity. This phenomenon has been explained in the following manner. A given point upon a luminous surface can never appear equally bright to both eyes, because it does not reflect the same amount of light in every direction. We know this, in a general way, from the fact that such luminosity changes its position with the movement of the head. It is to this

peculiarity that luminosity, in a great measure, owes its existence. Now the same effect is produced by looking at the two pictures, one of which appears black to one eye, and the other white to the other eye. They do not combine so as to form an equal tint of grey, but a *struggle ensues between the fields of vision*, the colour seeming to be first black, then white, and producing the sensation of luminosity. The change from dark to light upon the same point of the retina, produces an unpleasant quivering or twinkling light, which is caused by weariness. But, on the other hand, the alternating changes from dark to light in both eyes, which produces luminosity, is a pleasant sensation. In this case no unpleasant irritation of the retina takes place, such as is caused by a flickering light, but our attention moves from one field of vision to the other, and it is the alternation, apparently, which pleases us. The pleasure which luminous bodies give, and which it is natural for all men to feel, only lasts while the luminous body transmits those changing lights to the eye ; it ceases as soon as the surface becomes perfectly smooth, and, as a looking-glass, reflects to us the naked truth.

It is very interesting to observe how faithfully this luminosity is reproduced in photographic stereoscopes. The gleam of the setting sun upon the rippled surface of the sea, the brightness of columns of marble, appear in the pictures just as they do in reality, and yet, when we look at each single picture with the unaided eye, we can only see the dark and light spots, which could never give the impression of luminosity. But when we look closely we see that many spots in the one picture are dark, which

are light in the other. It is the combination of the two which produces luminosity.

The struggle between the fields of vision, which has been mentioned above, is still more remarkable, if, instead of black and white, we choose two colours, blue and red for instance. We do not then see a single mixed tint, as we might be led to suppose, but a hazy uncertain passage from one colour to the other, which wanders hither and thither. Here and there a mixed tint is seen, and the whole has a somewhat luminous appearance.

The struggle between the fields of vision is also called into action, if two differently coloured glasses are placed before the eyes, when looking at a white surface. The interchange of colours is quite irregular, one colour appearing in the midst of the other without any rule. Some experimenters, however, assert that they see one colour or the other at will, from which it would appear that we are able to give special attention first to the image on the right retina and then to that on the left.

The union of the two retinal pictures into a single picture in relief still remains one of the most wonderful phenomena of the senses, in spite of all these observations, which some regard as quite a sufficient explanation. We must be satisfied for the time in fixing the physical and physiological conditions of these phenomena. The representation of the material world is a distinctly mental act which takes place in the brain, and as such will, for a long time, escape scientific research.

CHAPTER IX.

Optical Illusions—Apparent Size of the Moon—Intuition—Illusions of the Sense of Colour—Mental and Corporal Vision.

HOWEVER perfect may be the optical apparatus with which nature has provided us, there are cases in which we see things differently to what they are in reality. Such phenomena we call *optical illusions*, and they are the more interesting because they give us a closer insight into the act of perception.

We can judge with tolerable accuracy as to whether two lines are parallel to each other or not. Zollner, however, has remarked that we are subject to a curious deception if the parallel lines are crossed by short oblique lines which slant inwards as in fig. 46. The lines 2 and 3 appear at first sight to widen downwards, the lines 1 and 2 upwards, and yet they are exactly parallel to each other when measured. The oblique strokes on the lines 2 and 3 would intersect each other if extended downwards, and the result is that the lines themselves look as if they would intersect each other if extended upwards. Thus the apparent convergence of the lines always has an opposite direction to that of the oblique strokes.

This phenomenon may be explained as follows :— The oblique strokes produce an error of judgment by leading us to imagine that, because they would intersect if produced in an upward direction, the lines must do so if produced in a downward direction. The delusion is stronger if the lines are placed in a horizontal position.

This bewilderment of the judgment in many cases gives an apparent motion to objects. The most familiar example is the giddiness which is felt after we have turned the body round rapidly. For a short time, after the motion has ceased, the objects round us seem to move in an opposite direction. A somewhat similar phenomenon takes place if a number of objects are moved rapidly across a stationary background. In looking, for instance, at a waterfall, through which the rocks are visible, we are, after a time, seized with the impression that the rocks are moving upwards.

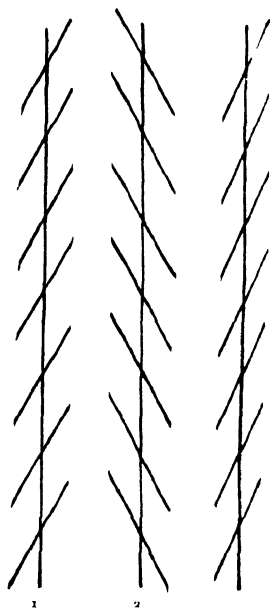

Fig 46.

In these cases we transfer some of the rapidity of the object in motion to the object which is at rest, but in the opposite direction. This phenomenon is still more striking if, when sitting in a train which is not in motion, we look at one which is passing. We are very

frequently impressed with the idea that we are moving ourselves, and the other train is standing still, and we can only undeceive ourselves by looking at the motionless objects through the other window. In this case we transfer all the rapidity of the other train to ourselves, and thus receive the impression of motion.

It seems as if the motion of the eyes played a considerable part in many of these illusions. When looking at Zollner's figure, our eyes may easily be displaced from their ordinary position, by rotation round their axes, into an oblique position, from looking at the oblique lines, so that the vertical planes of the optical axes are at an oblique angle to each other instead of being parallel, and this may contribute towards the error in our judgment as to the direction of the parallel lines. In support of this view Helmholtz mentions the fact that, in the momentary illumination of the electric light, the illusion is absent or at least much weaker, because in the moment of vision there is not sufficient time for the eyes to make any movement.

The movement of the eyes can also assist in producing giddiness. For whilst we are turning round, the eye tries to fix for a time every object seen, and in our revolution passes in a backward direction to the next object. In this manner a backward motion of the eyes is produced which will continue for some seconds after our own motion has ceased, and it is probably this which causes the apparent motion of objects. At least all the motions of the eyeball, which are made by the muscles of our eyes, independently of our consciousness or will, give rise to an apparent motion in the surrounding objects. This is the case in the rapid motion of the

eyes in illness, which produces a feeling of giddiness. This apparent motion of objects is observed if we displace the eye-ball with the finger, and move it gently backwards and forwards. Objects will then appear to move in an opposite direction to the motion of the eye-ball, because we are unconscious of the motion of the eye-ball in the reverse direction.

A somewhat similar effect is produced by looking for some time at objects in motion. In looking at a waterfall the eye endeavours to follow the falling mass for a certain distance, and from continually returning to the first point, acquires a backward motion. If we continue looking for some time, we shall notice that the stationary objects round us appear to be moving upwards because we are unconscious of this downward motion of the eye.

This confusion of our judgment on horizontal, upward and downward directions is of frequent occurrence. Let

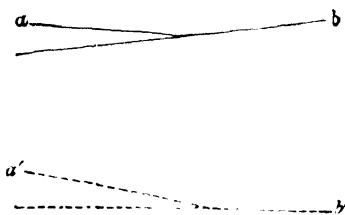

Fig. 47.

us suppose, for instance, that when walking down a gentle incline *b* on a road (fig. 47), we see at some distance before us a road *a*, which has exactly the same inclination, and which joins *b*. We shall find that we

generally exaggerate the incline of a and are surprised at finding it much less steep than we had supposed. This illusion seems to arise from our taking the road b , upon which we are walking, as the base by which the incline a is to be estimated. Our imagination identifies b more or less with a level surface, which is our ordinary standard, and, therefore, the road a , as may be seen in the dotted figure ($a' b'$), appears to be steeper than it is in reality.

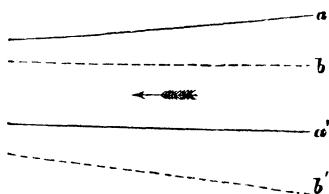

Fig. 48.

Sometimes, in mountain districts, we meet with another remarkable illusion: a brook will appear to set the laws of gravitation at defiance, and to flow uphill. If we are walking downhill upon a road a , near which a stream b flows, which has a more gradual fall than the road, or, perhaps, is nearly horizontal, we shall imagine that the stream is flowing uphill in the direction of the arrow. In this case, again, we imagine the road to be horizontal, since we have been accustomed to employ it as the base by which we estimate the position of surrounding objects; and, therefore, as $a' b'$ shows, the stream appears to be flowing in an upward direction. The apparent uphill flow of the water is still more striking if it flows in a trough over the downhill road.

We are also liable to many errors in our estimation

of the size of objects. It is a well-known trick to ask a person to fix the spot on the wall to which a hat would reach if placed against the wall on the floor. When the hat is placed against the wall, the height to which it reaches is found to be considerably less than was supposed. The reason of this illusion is that we always see the wall foreshortened, but the real size of the hat is impressed upon our memory, and, therefore, we always exaggerate in our minds the height upon the wall to which we imagine it would reach. Moreover, in the uniform surface of the wall we have no measure by which we can estimate its distance, and in such cases it is always observed that we imagine the distance to be greater than it is in reality. Upon a papered wall where the lines act as a guide to our judgment, the illusion, of course, is not so great.

We can give these observations a more definite form in the following manner. Imagine two squares of equal

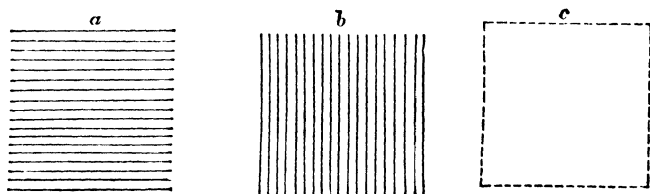

Fig. 49.

size composed of parallel lines (fig. 49), vertical in the one case and horizontal in the other. We shall find that, at the first glance, in the latter case the height appears to be greater than the breadth, as in fig. *a*, while in the former (fig. *b*), the breadth is, apparently, greater than

the height, and both appear to occupy a greater space than the square c , of equal size, but without lines. In this case we base our estimate of the size of the squares upon the number of intervals between the lines, the sum of which gives us an idea of the size of the square, which we do not obtain when we look in a horizontal direction along the lines. The sum of the parts appears, therefore, greater than the whole, because, in the former case, we obtain an idea of the size of each part, whilst the undivided whole does not produce such a vivid impression of its contents upon our imagination. We imagine, therefore, that the empty square cannot contain the other two, although, in reality, its size is exactly the same.

Our vision, again, is subject to various illusions when exercised in cases in which it has had no experience. If, for instance, we see people walking on a small hill the summit of which is sharply defined against the sky, and if their figures stand out against the horizon, they appear to be of a gigantic size, although, when seen close at hand, they are not above the usual height. This error in judgment is due to the fact that the figures are standing out against the horizon, and that, according to our ordinary experience, all objects upon the horizon are at a considerable distance from us, which has accustomed us to consider this distance in our estimation of size, and to imagine that all objects seen upon the horizon are necessarily of a considerable size. It is this experience which, under a change of circumstances, leads our judgment into error, for in this case we imagine that the persons seen are at a greater distance than they are in reality.

There is a common question: What is the apparent size of the moon in the sky? Some will say as large as a plate, others as large as a florin, and others, again, hardly as large as a sixpence.

It is clear that neither the question nor the answer has any strictly scientific meaning. For those who know that the moon is a great sphere, whose diameter is 2,160 miles, and which travels through space at a distance of 237,600 miles from the earth, will never compare its size with that of objects upon the earth, but will always have an idea of a very large and very distant sphere. But to the inexperienced eye the stars in the heavens appear to be all fixed at equal distances from us on a surface, which stretches over the earth like a vault. The heavens appear to have the form of a rather low bell placed like a lid upon the horizon, which seems to be at a greater distance than the zenith, although we never form any definite idea of this distance. Here it seems as if the disposition of the moment, or our individual conception played the principal part, and that on this depends the object with which we compare the apparent size of the moon. If we cut a small circular hole about the size of a sixpence in a sheet of paper we shall find that the moon can be seen perfectly through this hole, when it is held at a short distance of some steps from the eye. But if we make a hole as large as a plate, it must be held at a distance of several hundred yards to allow the moon to fill it exactly. The object, therefore, with which we compare the apparent size of the moon is quite an arbitrary matter.

Another circumstance however, which is not arbitrary, deserves scientific consideration. Everyone has

remarked how much larger the moon appears to be when sinking below, or just rising above the horizon, than when it stands high in the heavens. In this case we have not to deal with the refraction of rays of light in layers of air of different density ; for although refraction causes an apparent elevation of the heavenly bodies above the horizon, so that the sun and moon appear to be flattened out in a perpendicular direction, no real increase in the apparent diameter can be produced in this manner.

Two reasons may be given for the cause of this illusion. In the first place the heavens present to us the appearance of an ellipsoidal bell. We, therefore, suppose its edge upon the horizon to be at a greater distance from us than the highest point in the zenith ; and since we imagine the moon to be placed upon the even surface of the heavens, we imagine it to be at a greater distance when upon the horizon than when in the zenith. But we know from experience that the apparent size of an object decreases as its distance from us increases ; and that the greater the apparent size of a distant object, the greater shall we imagine its real size to be. Now since the moon seems to be more distant when on the horizon than when at the zenith, its apparent size still remaining the same, we suppose its real size to be greater when on the horizon than when at the zenith.

But a second cause of this optical illusion is the fact, that when the moon is on the horizon, we compare its size with the size of objects on the earth. If, for instance, the moon is near a house, we see that it occupies a much larger space than the house ; and we involuntarily try

to imagine how much larger such a ball would be than the house if it really stood near it. In this manner we arrive at an idea of size which is comprehensible to ourselves, and of considerable importance for terrestrial objects. We cannot make a comparison of this kind when the moon stands high in the heavens ; and, as the space which it then occupies appears to us very insignificant, when compared with the entire surface of the heavens, it follows that we are inclined to compare it with smaller objects.

The cause of many optical illusions may be traced to the fact, that, in many cases, we have no competent standard for estimating the size of the objects seen. Fancy then comes into play and often causes very curious illusions. If, for example, we see a weathercock upon a steeple in the position shown in fig. 50, we have no means of judging whether it is turned away from us or towards us. Indeed, we can imagine, through an effort of the will, the one in the drawing to be turned first one way and then the other. We are, however, generally enabled to judge of its true position by means of certain accessories, such as light and shade, or its motion. But when deprived of such aid, we are often at a loss as to its position, or merely by an effort of the will can suppose one or other to be the true direction. This, of course, is only the case when we are at such a distance from the steeple that we are unable to judge of the distance of the shaft and the free end of the weathercock, which is exactly reversed in the two positions.

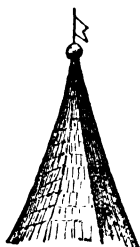

Fig. 50.

In all such cases, where our conception of the object seen allows of several interpretations, our imagination accepts one of these interpretations and neglects the other, though at the same time

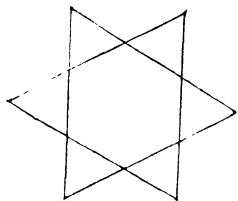

Fig. 51.

we are able to pass from one interpretation to the other. This property of the imaginative faculty has been called *Intuition*. The following example will serve as an explanation of this property. We can form two different conceptions of the accompanying

fig. 51, first as two equal triangles, the sides of which intersect each other. This would be the most natural idea. But it is also possible to view the figure as a hexagon, the sides of which are set with small triangles. The impression made by the figure in the two cases varies with our idea of its origin.

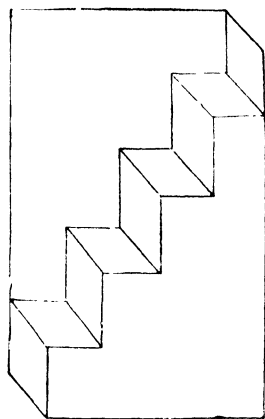

Fig. 52.

It is the same with the drawing in fig. 52. We can imagine it to represent either a staircase against a wall, or an overhanging portion of a wall, the lower part of which has been removed, and whose under surface has taken the form of steps. Our idea of its form changes quite arbitrarily.

Passing to our sensation of colour, illusions again occur which are caused by errors in our judgment.

Place a small square of white paper on a large piece of green paper, and cover the whole with a thin transparent piece of tissue paper so that the underlying paper is seen through it. The small square will then appear red, while the surrounding surface seems whitish. If shown to an unprejudiced person, who does not know what is under the tissue paper, he will immediately pronounce the small square to be red, and will hardly notice any colour on the surrounding surface. Under similar circumstances a white square upon a red ground will appear green, a white upon blue, yellow, and *vice versa*.

We might, in this case, be led to imagine that we had merely to deal with the ordinary phenomena of complementary colours, which are produced when the eye, after having been fixed for some time upon a coloured surface, is turned suddenly upon a white one. The white surface will then look red, if we have wearied the retina by gazing for some time at a green light ; or *vice versa*. But, in the case we are speaking of, the phenomenon cannot be explained by fatigue of the retina, because the colour of the larger surface is of so little consequence that it is scarcely recognised, and, therefore, cannot fatigue the eye by its colour. If the tissue-paper is removed, we immediately recognise the small square as white, although the fatigue produced by the coloured surface would be still greater.

Phenomena like those just described have been termed *Simultaneous Contrasts* by Helmholtz. They are explained by our having made an erroneous judgment on what we call white light. We call a body white when it reflects all the colours of the spectrum in the proportions in which they are contained in sunlight

But we are accustomed to slight variations in these proportions, and call such variations white also. This is the case in the experiment under consideration, in which we suppose the coloured surface, which is covered with white paper, to be white. The result is that we do not recognise the true white of the small square as such, but as a white which inclines to the complementary colour.

It is very probable that the kind of light which we call 'white' would not remain the same if the proportion of the colours in the light of the sun were to alter; and since we suppose even the sun and its light may not remain the same for ever, it is quite possible that our descendants may have a perfectly different idea of white to that which we now have.

It is in these illusions of the organ of vision, and, also, of the other sensory organs, that we are best able to recognise the important part which the Mind plays in the perceptions of the senses, for it is the mind alone which is able to alter the perceptions of the senses, and, thereby, in many cases to create illusions. We see, further, that it is by the activity of the Mind alone that the *Sensations* of the senses are converted into *Perceptions* of the senses. For the sensation of the senses, *i.e.* the excitement of the sensory organ and the passage of this excitement to the brain, does not at all imply the connection of this sensation with a perception of an object or occurrence in the external world. In regard to animals, and especially in pigeons, the observation has been made, that upon the removal of the cerebral hemispheres, in which state they may live for some time, they still possess a sensation of light, which penetrates the eye, and causes a contraction of the pupil; an action which can only be caused by the

central organ of the optic nerve in the brain. But a comprehension of the objects seen—*i.e.* a true perception of the senses—is no longer possible to these animals. They behave like blind animals, run against every obstacle, and no longer possess the power of recognising the objects seen as belonging to the external world.

We cannot help conjecturing that the process must be the same in man: that the perception of the external world is essentially an act of the Mind, which has its seat in the cerebrum and is connected with this organ; and, further, that the sensory organ with its nervous connections only affords the brain the material which it converts into a Sensory Perception.

PART III.

THE SENSE OF HEARING.

CHAPTER I.

General construction of the Organ of Hearing—Sound as a Tone, a Note, and a Noise—Musical Instruments.

THE organ of hearing is not so fully exposed to our view as the eye. The latter exposes nearly the half of its surface to the light ; the former, on the contrary, conceals its most important parts deep in the solid structure of the head, and only exposes to view a very subordinate part, the Pinna or External Ear, which, on this account, in ordinary language, has received the unmerited title of the *ear*. The barbarous punishment of cutting off the ear, which was customary in olden times, and among uncivilized nations, has clearly proved that the external ear is not essential to the power of hearing. Moreover, most birds have no external ear, and yet they have a very good, and partly musical sense of hearing.

The relation of the organization of the ear to that of the eye is the same as the nature of the range of vision to the range of hearing. Our range of vision is limited

by an opaque body ; in a transparent medium, however, it extends to the infinite distance of the stars, when the ray of light penetrates the eye in an almost straight line to its posterior surface. The extent of our perception of sound, even in our atmosphere, is very limited, but sound can penetrate the thickest walls and travel by the most circuitous paths, so that in the deepest mines where no light can penetrate, the ear gives us certain information of the existence of an exterior world. Thus, the inner parts of the ear are hidden in a deep cavity in the skull, which is provided with many wonderful labyrinth-like passages. Sound does not penetrate these passages in a straight line, but passes along a very complicated path, composed of tubes, membranes, and the ear-bones.

In fig. 53, the essential parts of the organ of hearing are represented, in their natural size, after Helmholtz. We see the *Auditory Canal*, D, which terminates within

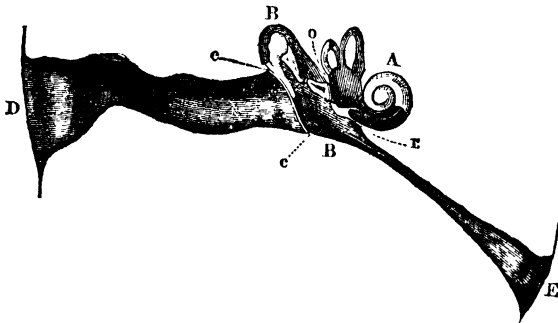

Fig. 53.

with the *Tympanic Membrane*, *c c*. This membrane is circular and stretched obliquely, and is followed within by a hollow, filled with air, B, the *Tympanic Cavity*,

whose walls are formed of bone. In it are situated the Ear-bones, three in number, called the Hammer (Malleus), the Anvil (Incus), and the Stirrup (Stapes). The hollow opens inwards and leads to a canal, the *Eustachian Tube*, *E*, which is extended in a trumpet-like form and opens into the Pharynx. On the inner wall of the tympanic cavity there are two openings closed with membranes, an oval aperture, *o*, *Fenestra Ovalis*, on which the base of the stirrup rests, and a circular aperture, *r*, *Fenestra Rotunda*, the membrane of which is free.

The two openings lead to the *Labyrinth*, *A*, a peculiar, coiled, bony cavity, the walls of which are clothed with membrane and remarkable organs, and the interior filled with the labyrinthine fluid. One side of it is distinguished by the name of the *Cochlea*, and the other, the *Semicircular Canals*.

From this rapid view of the essential parts of the ear, we find that the Auditory Canal, the Tympanic Membrane, and the Tympanic Cavity with the Ear-bones, only serve to receive the sound from without and to convey it to the interior, that it must there be communicated to the Labyrinthine Fluid, and that in the Labyrinth the proper physiological process of hearing commences, since at this point the apparatus for the transfer of sound terminates. In fact, the Auditory Nerve here penetrates the solid structure of the skull, and through its connection with most curiously formed terminal organs, changes the dead sound into a living sensation.

Although we can form no conception of sound, as such, except through the excitement of our auditory organs, nevertheless its origin and propagation in nature were recognised by physicists long before anything was

known of its physiological action. In this respect physical acoustics were, to a certain extent, just as independent of physiological knowledge, as was the case with optics; since, in the latter, the undulatory theory was developed, without any definite knowledge of the constitution of the retina, and of the excitement of the nerves situated in it. It must be granted that the exclusively objective physical study of sound and light must necessarily have made some progress to enable us to consider the functions of the sensory organs physiologically; and it has been shown, that many of the inventions which have been laboriously made by the ingenuity of man during the last century, are to be found in the greatest perfection already existing in the Sensory Organs. Nevertheless, in the present century, the science of physics has reached the point at which it may be considerably advanced by the physiological study of the sensory sensations, which study may provide fresh material for future investigations.

Among the sensations of sound, there is one kind of sensation different from all others, and which has a definite character of its own. This is the sensation of musical sound, which is distinguished by the terms *tone* and *note*. All other impressions of sound which do not possess this character may be included under the term *noise*.

A *tone* is produced as soon as any elastic body is set in rapid vibration. If, for instance, a thin piece of metal, or a knitting-needle, is fixed firmly at one end and its free end struck, it is then set in vibration, which is accompanied by a kind of hum or tone, and the shorter the part in vibration, the higher is the tone. The tone

of a tuning-fork is produced in precisely the same manner. Imagine the tuning-fork, in fig. 54, in vibration. The branches of the fork at each vibration approach first each other and then recede, an action which is not apparent to the eye, in the tuning-forks used for musical purposes, since the vibrations are too small and follow each other too rapidly. By means of the following contrivance the vibrations can be made self-registering. On one branch a pencil *b* is fixed, which makes

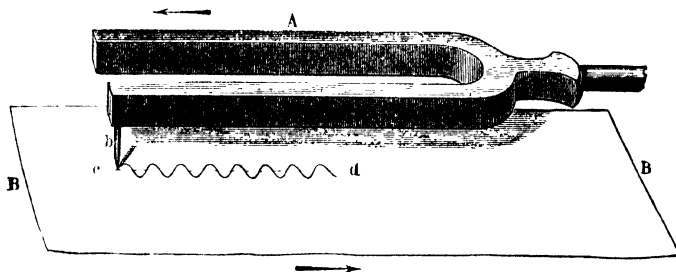

Fig 54.

a mark upon a plate B B, drawn rapidly before it. An undulating line is produced which gives the number of vibrations, if the rate of the motion of the plate is known. Fig. 55 represents an apparatus, the Phonautograph, with which such an experiment can be performed. The point, *r*, of the tuning-fork writes upon a cylinder, round which is rolled a sheet of paper covered with lamp-black. The cylinder can be set in rapid rotation by means of a handle, a screw, at A, giving it a gradual forward motion during the revolutions. Two wires lead from the fork and the cylinder to a

strong induction coil, which, by means of clockwork, gives an electric spark every second, which makes a hole in the blackened paper. By this means the number of vibrations in a second can easily be counted.

Physicists have agreed to understand by the word *vibration*, a forward and backward movement of the vibrating body, so that a single vibration is represented by a curve of the undulating line, first in an upward, and

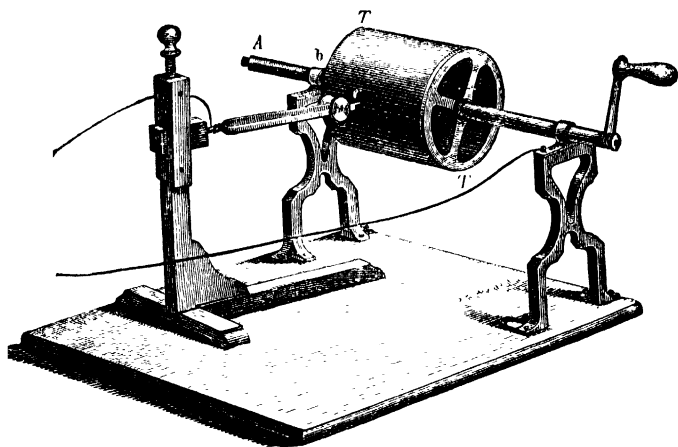

Fig. 55.

then in a downward direction. The body makes an *excursion* or *elongation* from its position of rest first to one side, then swings past its position of rest to the other side, and then returns to its position of rest again, after which the movement is periodically repeated in the same manner. The time occupied by the entire vibration is called a *period of vibration*, and its extent the *amplitude of the vibration*.

In all musical instruments the tones are produced by some such action as this. A stretched string, which produces the tone in pianos and stringed instruments, vibrates in the manner shown in fig. 56, by springing first to one side and then to the other. A glass plate or a bell sounds when it is struck, in consequence of the vibrations, which its particles make at right angles to its

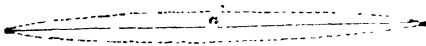

Fig 56.

surface. Such vibrations, which are made in a direction perpendicular to the length of the body, or better, perpendicular to the direction of the propagation of the vibrations, are called *transverse vibrations*. Longitudinal vibrations, however, can also produce tones ; for instance, metallic rods when struck upon their terminal surfaces, or wooden rods when rubbed in the direction of their length.

In the examples given the tone is caused by the vibrations of a solid elastic body. A tone, however, can be produced directly by vibrations of the air, when, for instance, we blow across the mouth of a hollow ball, of a bottle, or of a hollow cylinder. An instrument which rests on this principle is the *mouth-pipe*, which can be used in the organ, or as a flute. Fig. 57 represents two such organ-pipes. Air streams up from below into the chamber K from bellows, and is directed by the triangular piece of wood *d*, through a small cleft *c*, against the lip *a b*, by which it is made to blow against the column of air contained in the cylinder R R, and throws it into vibration. In this action the air is com-

pressed by the first shock, then expands, comes again in contact with the current of air, and is thus made to vibrate periodically, which vibrations consist of condensations and expansions.

The vibrations of the air consist of condensations and expansions, which follow each other with great rapidity, and a tone is always produced if the vibrations follow each other with periodical regularity. A tone can, therefore, be produced if a continuous current of air is interrupted with great rapidity and regularity. An instrument invented by Seebeck, in which this takes place, is called a *Siren*, and in its simplest form is shown in fig. 58. It consists of a disc, perforated with holes arranged in circles, and which can be set in rapid rotation. Air is blown through the tube B against the holes. The more numerous the holes, and the more rapidly the disc is made to revolve, the higher will be the tone produced. Each puff of air then produces a vibration of the air. The siren affords the means of determining the number of vibrations for any particular tone. If the disc A is provided with four series of holes, the number of which, counting from within outwards, is

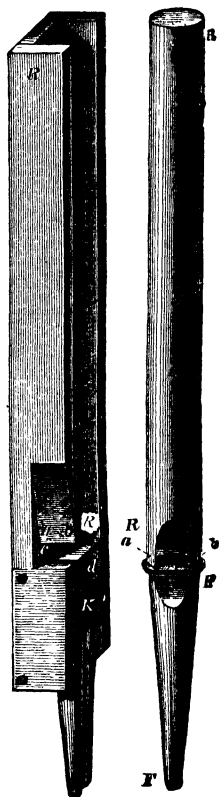

Fig. 57.

respectively 8, 10, 12, 16, and if we blow upon them in this succession, we hear the recognised chord, which, starting from the note *c*, may be distinguished by *c, e, g, c'*.

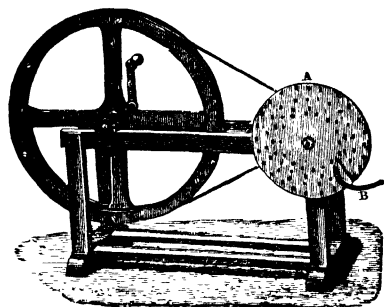

Fig 58.

The quality remains the same for every rate of revolution, provided the rate is constant, only the absolute pitch and character of the tones change with the rapidity. If we had a disc which was provided with rows of holes, corresponding to an entire scale, we could then produce perfect melodies upon it.

In this instrument the tone is caused by the sudden expansion experienced by the current of air, which issues from the tube as soon as a hole comes before the opening of the tube, and by its sudden condensation as soon as the hole is past. This action is then transmitted through the air to our ear in the form of waves of sound.

A more complete form of siren, constructed by Dove, is shown in fig. 59. A current of air is blown through the tube, B B, into the chamber, A A. The latter is provided with a lid, which is perforated by a number of

holes; close above it is a disc *s s*, which revolves upon a perpendicular axis, and is perforated by the same number of holes in an oblique direction. The holes of

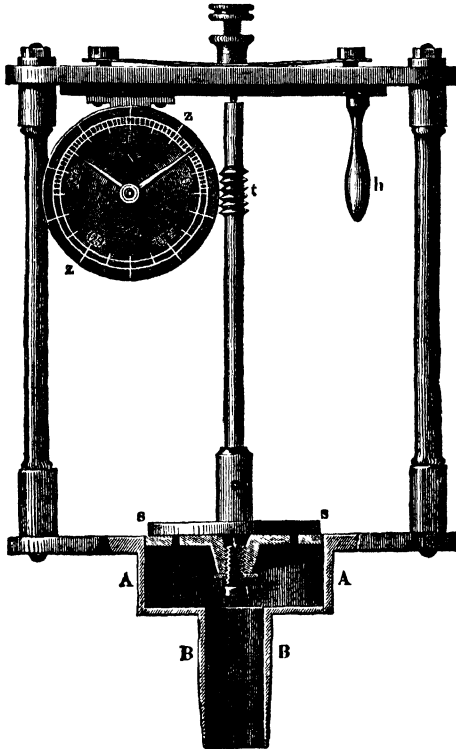

Fig. 59.

the lid, also, can be inclined in the opposite direction. The current of air in its passage through the instrument, strikes against the sides of the holes in the disc, and

sets the disc in rotation, the rapidity of which gradually increases. The interruption of the current of air causes a tone, the height of which gradually increases, and on this account produces the unpleasant impression of a howl. Since the number of revolutions can be read off, by means of a toothed wheel with a dial and pointers, $t z z$, as soon as the toothed wheel is put into gear with the screw, t , by the handle, h , we are then able to discover the number of puffs of air, that is to say, vibrations for each particular note.

There is another method of producing tones which is employed in music, *i.e.* by means of *Reed-pipes*, which are used in organs, clarionets, oboes, and bassoons. In the instruments which have been mentioned hitherto, the tone is produced either by a fixed body in a state of

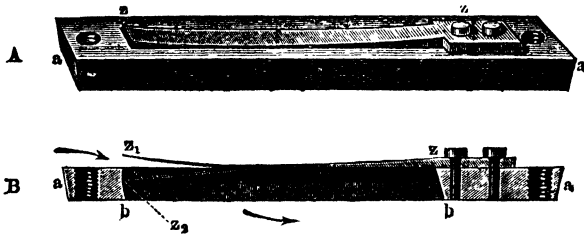

Fig 60.

vibration, a string, a tuning-fork, etc., without any current of air reaching it, or by the interruption of a current of air, without it setting any elastic body in vibration—as in the siren. In reed-pipes, on the contrary, both methods are employed, and together they produce a peculiar note of their own. The solid vibrating body here consists of the so-called Tongue, fig. 60. An elastic strip of

metal $z z$, is fixed at one end and is allowed to vibrate freely in the orifice $b b$, of a frame $a a$. The tongue forms one side of a closed tube, which is open above, and which can be placed in a wind-chest (fig. 61). The current of air which is blown through the lower tube of the wind-chest can only escape through the orifice between the tongue and the frame. The air first presses the tongue into the tube, and escapes by the upper opening, to which a funnel-shaped tube should be fixed to strengthen the sound. The tongue, however, by reason of its elasticity, springs back again, covers the opening, and periodically interrupts the current of air by its movement to and fro. A tone is thus produced, the pitch of which is determined by the number of vibrations made by the tongue. In some instruments the tone can be changed by a moveable wire, the position of which may be changed so as to increase or diminish the length of the vibrating tongue.

Trumpets and horns are wind instruments, in which the lips of the performer play the part of a tongue.

The extended lips are set in vibration, while the tube of the instrument serves as a resonator, and considerably increases the intensity of the tone. There is, therefore,

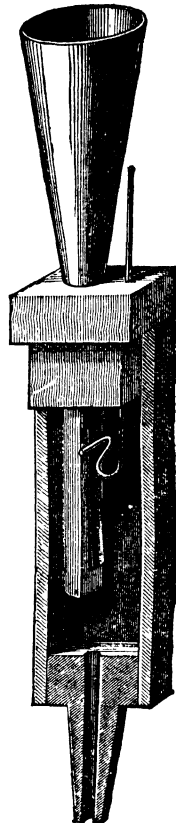

Fig. 61.

a peculiar art in playing these instruments, since no tone whatever is produced, however strong the current of air may be, if they are placed in the open mouth.

The formation of the *human larynx* is exactly similar to that of the reed-pipe. The tongue is formed by the *vocal-chords*, two elastic membranes, whose free edges enclose a narrow slit, which, in fig. 62, is artificially imitated by means of sheets of india-rubber. If we blow into the tube which is meant to represent the wind-pipe,

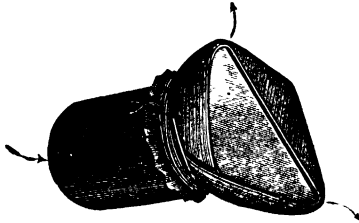

Fig 62.

a tone is produced which is not unlike the human voice. The sheets of india-rubber are made to separate, and the slit is thus opened ; their elasticity brings them together again, which gives rise to a periodical interruption of the current of air. Such an apparatus is called an *artificial Larynx*.

CHAPTER II.

Hearing through the Air and through the Skull—The External Ear and the Auditory Canal—Recognition of the Direction of Sound—Arrangements for the Protection of the Ear.

THE proper sensation of hearing commences at the expansion of the auditory nerve in the labyrinth, whilst, hitherto, the only action has been the conveyance of the sound-waves. The first process in hearing is, therefore, the conveyance of the sound to the fluid of the labyrinth, the waves of which have the power of exciting the expanded nerves. The sound is generally conveyed from the surrounding air to the labyrinth through the auditory canal, the tympanic cavity, and the ear-bones. For, every body which vibrates in the air, throws the air which surrounds it into similar vibrations, which extend outwards from the point of their origin, in the form of a circle, while their intensity decreases with the square of the distance. The vibrations consist of condensations and expansions of the air, which follow one another, like circles of waves upon the surface of water, as is represented in fig. 63. Sound, however, can pass through solid bodies also, without the intervention of the air, and reach the labyrinth in this manner. If we strike a tuning-fork

gently, and hold it before the open mouth, we hear nothing ; but as soon as it touches the teeth we hear its tone quite clearly, since it is now conveyed directly to the labyrinth through the skull, without passing through the



Fig. 63.

tympanic cavity, or the ear-bones, at all. We can also hear the ticking of a watch if we touch it with the teeth, or press it upon the bones of the skull just behind the ear. Moreover, there is a well-known children's game, which depends chiefly upon the conveyance of sound to the ear through bone. A metallic spoon is fastened to a string, which is wound round the first finger, and the finger pressed firmly into the auditory canal. The spoon is then struck against the edge of the table, and the sound produced resembles that of a large bell, for the vibrations of the spoon are communicated to the labyrinth, through the thread, the finger, and the bones of the skull, with increased intensity.

The communication of sound through bone is of no value to man under ordinary circumstances, since we do not generally bring the head into close contact with the sounding body. In fishes, however, it plays a very important part, for they possess neither external ear, auditory canal, or ear-bones, but only a labyrinth, which is entirely

losed by walls of bone, or is only covered with membrane on its outer surface. The sound-waves of the water, therefore, are transferred directly to the fluid of the labyrinth through bone. This is possible because the sound-waves of water, which is well known to be incompressible, are similar to those of a solid body, and do not, like those of the air, consist of expansions and condensations. Sound-waves of the air, on the contrary, are transferred to solid bodies and to liquids with great difficulty; and to effect this, ingenious contrivances are required, which are found in their greatest perfection in our ears. Such contrivances are not required by fishes, for they have only to hear in water; indeed, an apparatus filled with air, if placed between the water and the labyrinth of their ear, would considerably diminish their power of hearing. In case of illness the communication of sound through the bones can be of considerable importance to us. If the apparatus for the communication of sound is diseased, and can no longer perform its duties, in spite of deafness, sound can still be communicated by means of bone, which then gives the physician a very important diagnostic sign that the labyrinth and the auditory nerve are in a sound condition.

The regular action with which we have to do is the conveyance of sound through the air, beginning with the reception of the sound-waves by the external ear and the auditory canal, and ending with the transfer of the same to the labyrinthine fluid. In this path there are many ingenious contrivances, which are deeply interesting. Although there is much in this action which is not yet explained with sufficient certainty, still, since the investigations of Helmholtz upon the tympanic cavity,

many discoveries have been made which have opened the way for new enquiries. Of course enigmas still occur, as is generally the case in nature.

A consideration of the curiously coiled folds, furrows, and hollows of the human external ear might lead us to suppose that nature has created all these details for some definite purpose, as well as for the beautiful form which may accompany them, and which nature often puts to some practical purpose. Nevertheless, it would be very difficult, from a scientific point of view, to establish such a supposition, although formerly it had not a few adherents; and we arrive at a very different conclusion, if, as is frequently the practice in physiology, we pass from human anatomy to the animal kingdom, and consider the form of the external ear we meet with there.

The external ear, together with the auditory canal, certainly forms a funnel-shaped ear-trumpet, which, in horses for instance, we find in a form which answers this purpose, as a true funnel with tolerably smooth walls. The marked strengthening of the sound produced by a funnel-shaped ear-trumpet, which can easily be imitated by placing a roll of paper in the ear, is especially remarkable if we close the other ear and then listen to the general rustle in the air; or, still better, if we endeavour to hear the ticking of a watch placed upon the table at a slight distance, with and without the tube. The sound-waves which fall upon the wide opening are reflected inwards by the sides of the tube, and this causes a continual increase in the intensity of the sound-waves, *i.e.*, the amount of the condensation and expansion. While this function is fulfilled to a considerable extent by the ears

of a horse, and all the more from the ease with which they can be moved in any direction, the human ear appears to be but little adapted for this purpose. For, in the first place, its form deviates considerably from that of a funnel, which is only partly assumed by that part which joins the auditory canal, D (fig. 53); and, secondly, the external ear in man is almost unmoveable, although there are muscles which can give it an upward, backward, and forward motion. Man, however, seldom possesses any command over the muscles of the ear, such, for instance, as that possessed by the celebrated physiologist, Johannes Müller, so that 'moving the ear' is a peculiar art.

This want of mobility can be explained by the fact that the motion would be of no special use, and we have, therefore, no cause for such useless motion, so that ultimately the will loses its influence over these muscles. Whilst this connection of phenomena points to the small importance of the human external ear as an ear trumpet, this conclusion may be confirmed by the following experiment: after a small tube has been placed in the auditory canal, the entire ear may be filled up with a mass of dough, without any diminution being observed in the acuteness of hearing.

Nevertheless, the external ear has some influence on the hearing, for a marked difference is produced by an artificial increase in the size of the external ear by means of the hand, which is a general practice with deaf persons when they wish to hear more distinctly. The endeavour has also been made to discover whether the angle which the surface of the ear makes with the side of the head may not have some effect on the acuteness

of hearing, and it has been supposed that an angle of 40° is most suitable for this purpose. Still, most persons might well object, on æsthetic grounds, to such a large angle, especially when the change of the position of the ear with regard to the head makes scarcely any perceptible difference to the hearing. It has also been supposed that, in consequence of its being composed of elastic cartilage, it has the power of receiving the sound-waves from the air, and conveying them through its mass to the auditory canal and tympanic membrane, and that its surface is increased for this purpose by such a number of folds. But such an action can only be very unimportant; for if the ears are entirely closed with wax, we are rendered quite deaf to all sound which is conveyed by the air, and the external ear renders us no perceptible assistance. Nor do we hear the ticking of a watch, if it is placed on the cartilage of the ear when the auditory canal is closed, while it may be heard very distinctly if placed on the bone behind the ear. We must, therefore, consider cartilage as a bad conductor of sound.

The next question is, whether the external ear renders us any assistance in recognising the direction of sound. Doubtless we are able to recognise the direction of sound, but we also learn from experience that in this recognition we are liable to many errors of judgment. We recognise the origin of the sound-waves by the fact that the sound is heard most distinctly when the auditory canal is in the same straight line with the direction of the sound-waves. For this purpose we turn the head in different directions until the sound appears to us to be loudest. In this case only a single ear acts, and the sound must have sufficient duration to enable

us to determine its direction. Very frequently, however, the direction of a sound may be recognised directly with the aid of both ears, without any further examination, since the sound appears louder when heard by the ear which is turned in the direction of the sound than when heard by the other. In this case, hearing with both ears plays a not unimportant part, which may be compared in some respects with binocular vision, although here we have to do, not with the estimation of distance, but only of direction. But in hearing with one ear we have to make use of the movements of the head, just as we do in monocular vision, when we wish to estimate distances. Nevertheless, we cannot exactly determine the distance with both ears; therefore, in a careful search for the origin of sound, we almost always turn the head.

In this action the external ear performs a really important service. When, for instance, we turn the head towards the origin of a sound, then the external ear is situated in about the most favourable position for the reflection of the sound-waves into the auditory canal, less favourably if the sound comes from the front, and most unfavourably if from behind, since those sound-waves which fall directly upon it will be reflected outwards. We can then easily form an opinion as to whether the sound comes from before or from behind, especially if we have already gained experience of the usual intensity of sound, and, still better, if we have made comparisons by turning the head.

However, the supposition has also been made by Ed. Weber, that the external ear has the power of perceiving the direction of the sound-waves by its being set in vibration itself, and that we can determine whether the

sound-waves have fallen upon the anterior or posterior surface. In this connection the following highly interesting observation of Weber's should be mentioned. If we are observing a sound which reaches us from the front, and place both hands, turned backwards, upon the head in front of the ears, so that the hollows of the hands represent the exterior portions of the ears, then we experience the illusion that the sound comes from behind. Weber supposed that while the hands played the part of the exterior ear, they were also capable of perception, that their backs received the shock of the sound-waves, and on that account we fancied that the sound came from behind. If this explanation were correct, then we should be forced to conclude that the tactile nerves of the exterior ear, and of the hands, were able to feel the movement of the sound-waves in the air, for special nervous terminal apparatus are not to be found in them. Moreover, the tactile sense is much weaker in the external ear than in the hollow of the hand, and we certainly do not feel sound-waves as such with the hand; for instance, if we close the upper end of an open mouth-instrument with the hand while it is sounding. It is therefore improbable that the skin of the external ear is able to perceive the direction of sound-waves.

The power of determining whether a sound comes from before or behind is much more simply explained by the diminution which sound suffers when it comes from behind. In Weber's experiment, therefore, in which the hand is held before the ear, the sound is deadened by the hand much in the same way as when it comes from behind.

Weber has also observed that it is very difficult to

distinguish whether the sound comes from before or behind, if we place the external ear flat upon the head ; which can easily be explained in both ways. According to Weber, because the posterior surface of the external ear is not affected by the sound-waves, and according to our view because the means for the conveyance of sound are very similar in both directions.

Finally, the external ear has to be considered as a means of affording protection to the inner ear. Just as the eyelids prevent the entrance of many injurious substances into the eye, so the external ear prevents the entrance of dust and small particles, which might easily be blown through the air, into the auditory canal ; and to prevent the entrance of insects, not by a closing movement, but, in the human ear, by means of its peculiarly coiled form, which makes the entrance difficult to find. The latter, also, is more or less covered with minute hairs, which serve to catch any dust which penetrates without perceptibly deadening the sound.

The auditory canal, the first part of which is composed of cartilage, and the inner part of bone, as we have seen from the figure, is not a straight tube of equal width. It is contracted at the opening, which contraction turns inwards and upwards ; then it expands and terminates at the tympanic membrane, the surface of which is placed at an oblique angle to it, and is directed inwards and downwards. On the sides a fatty substance, *the wax of the ear*, is secreted by small glands, which is intended to keep the sides, and perhaps the tympanic membrane itself, in a supple condition, and to protect it from dryness. An excessive secretion of it may be injurious and produce deafness, by closing the passage.

We must not assume that the inequalities in the auditory canal have any particular influence on the conveyance of sound, for if we hear a sound through an india-rubber tube it makes but little difference whether the tube is straight or bent, since the reflection from the sides allows the sound to pass along it with scarcely any diminution in intensity. The irregularities, therefore, cannot have any special acoustic influence; perhaps they only serve as a protection, by keeping any dust which may enter the ear from reaching the tympanic membrane.

The auditory canal has been proved by Helmholtz to have a special resonant action. Since every enclosed volume of air gives its fundamental tone, when we blow across it, as with the mouth-pipe, a bottle, or a hollow globe, the auditory canal, also, must possess such a fundamental tone. The pitch of this tone is tolerably high, so that tones of the same pitch, in consequence of this strong resonance, seem shrill and unpleasant to us; as for instance, the very high tones of a violin or the cry of a bat. Perhaps this is also the cause of the unpleasant sensation produced by the screech caused by scratching glass or porcelain with certain metals. Upon the whole, the resonant action of the auditory canal strengthens the high tones in some degree, and deadens the low ones; this can be varied by placing a small tube of paper in the auditory canal, and by this artificial elongation lowering the pitch of fundamental tone.

CHAPTER III.

The Tympanic Membrane, the Tympanic Cavity, the Ear-bones, and the Eustachian Tube—The Vibrations of the Tympanic Membrane and of the Ear-bones.

THE tympanic membrane has not an even surface, but it shows a depression, which is directed towards the tympanic cavity. This is caused by the union of the membrane with the handle of the hammer, which is firmly attached to the tympanic membrane throughout its entire length, its end corresponding with the centre of the depression. In fig. 53 this relation is roughly represented; fig. 64, however, shows us the tympanic membrane, after the view of Helmholtz, in its connection with the hammer, as seen from the tympanic cavity; fig. 65 shows the three ear-bones (*ossicula auditûs*). It shows that the tympanic membrane is contracted inwards into a funnel-shaped depression by the handle of the hammer, and that the centre of the depression is found beneath the middle of the handle. The tympanic membrane, therefore, has a concave form, from the edges to the central depression; but as seen from the auditory canal, it bulges inwards like a sail. The edge of the tympanic membrane is inserted into a bony groove.

Within the membrane is found a layer of muscular

fibres, part of which extend in a radiating, and part in an annular direction. In the figure other details may be observed—the head of the hammer *h*, its long pro

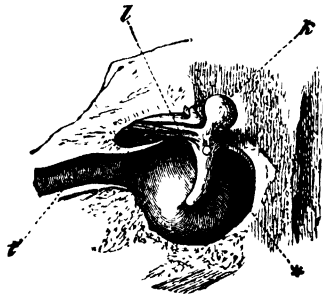

Fig. 64.

cess *l*, and a point *, upon which a tendon of the *Tensor Tympani* muscle is fixed. We see also a ligament below the head, which fixes the hammer and the mouth of the Eustachian tube *t*.

In fig. 65 we have a representation of the form and connexion of the ear-bones magnified four diameters. The head of the hammer, which extends above the upper edge of the tympanic membrane, articulates with the anvil bone *Am*. Besides the long process *l*, there is a short process close under the neck of the hammer-head, not seen in the drawing, which is directed outwards and presses against the upper edge of the tympanic membrane, and is here slightly turned up in an outward direction.

The general form of the anvil is that of a bicuspid tooth, whose upper surface articulates with the hammer-head. Two processes descend from it like roots, the

shorter of which *Am. k*, is directed towards the posterior side of the tympanic cavity, and is attached to it by means of ligaments ; whilst the longer one, *Am. l*, projects into the interior of the tympanic cavity, and, by means of a small joint at its termination, articulates with

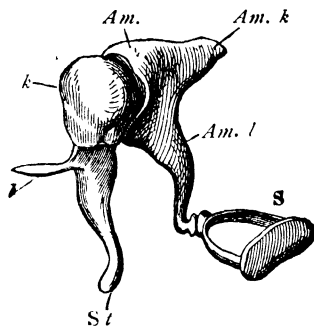

Fig 65.

the head of the stirrup *s*. The stirrup, whose form is at once suggested by its name, has an oval-shaped foot-plate, which points inwards and presses against the fenestra ovalis of the tympanic cavity.

The tympanic cavity is a moderately small cavity, which extends above the upper edge of the tympanic membrane. It may be compared to a drum, which is only covered on one side with a membrane—the tympanic membrane. Still it differs from the form of a drum chiefly because it passes downwards, forwards and inwards into the Eustachian tube.

This canal, which leads to the pharynx, serves an important purpose. The tympanic cavity is a space situated within bone and filled with air. If this air were entirely shut off from the atmosphere, it would soon

change its composition, and would probably be absorbed by blood and replaced by liquid secretions, if a continuous renewal were impossible. This renewal can take place through the Eustachian tube, which, from time to time, allows of an exchange of air; but this canal performs other functions than a mere renewal of the air; it also maintains equilibrium of pressure between the air within the tympanic cavity and the atmosphere, which is of great importance for the proper action of the tympanic membrane. For, as soon as the pressure of the atmosphere is greater than the pressure within the tympanic cavity, the membrane will be compressed inwards; and if it is less than the pressure within the cavity, then the membrane will bulge outwards. Both would be injurious to the movements of the membrane, and are prevented by the Eustachian tube, which, at proper times, allows the entrance and exit of air. It does not, however, remain long open, but is generally closed, and is only opened in the act of swallowing—an act which is performed not only during eating, but frequently, at other times, for the carrying away of secreted saliva, and thus its function as an aid to the ear is sufficiently fulfilled.

Valsalva, a prominent anatomist in the seventeenth century, has shown by the following experiment how the Eustachian tube is opened during swallowing. The nose is closed, and the cheeks blown violently out with the mouth shut. If, now, under these conditions, we go through the act of swallowing, without allowing air to escape by the mouth—which is easily done after some practice—a peculiar pressure is immediately felt in both ears, which is caused by air having been forced through the Eustachian tube into the tympanic cavity, and by the

membrane being thus pressed outwards. This sensation lasts until we go through the act of swallowing again, which allows the excess of air to escape.

In a similar manner the air in the tympanic cavity may be rarefied. If we close the mouth and nose, rarefy the air in the pharynx by a strong inspiration, and perform simultaneously the act of swallowing, air is then drawn from the tympanic cavity, the membrane bulges further inwards, and a similar sensation of tension is experienced in the ear, from which we are freed in the next act of swallowing. But during this experiment of Val-salva our power of hearing is deadened and weakened, whence it follows, that in the condition of abnormal tension, the tympanic membrane does not perform its usual function.

The Eustachian tube is opened by means of muscles which are attached to its cartilaginous walls, and which move during the act of swallowing. In connection with this action, the question arises:—why the tube is not open continuously, but is generally closed, and only momentarily opened to be closed again directly? If this tube is intended for the exchange and renewal of air, it would surely be much simpler if it remained always open.

A tolerably decisive answer to this question can be given. The idea at once arises that sound-waves, also, could be conveyed through the open tube into the tympanic cavity. This can be shown to be possible by placing a tube in the Eustachian tube and allowing a sound to pass through it. Therefore, if the Eustachian tube remained open, our own voice would sound like a roaring noise, and even those persons who have a great predilection for hearing their own voice, would find its

continuance, under such an increase in intensity, disagreeable.

Moreover, if the Eustachian tube remained open, the passage of air inwards and outwards during respiration would cause movements of the air within the tympanum, and a consequent bulging inwards and outwards of the tympanic membrane. In short, we perceive that the closing of the canal is of great practical importance, and that a peculiar mechanism is required to open it from time to time.

Further, there is the possibility of the open Eustachian tube changing the vibrations of the tympanic membrane, and, of course, the resonance of the air within the tympanum. For when a drum is struck, the tone is changed as soon as an opening is made in its sides. Nevertheless, a theoretical and experimental examination is required before a similar influence can be proved for the Eustachian tube.

Finally, the tube provides means for carrying away the secretions, which are produced upon the membrane of the tympanic cavity. The passage towards the pharynx is, therefore, much more easy than in the opposite direction, in which the walls approach each other in a valve-like manner. During a cold the tube may become impassable, and then, through want of a renewal of the air in the tympanic cavity and the collection of mucus in it, a greater or less degree of deafness is produced, on which account aurists introduce a small elastic tube into the Eustachian tube as a protection against this evil.

Among the solid bodies, whose vibrations are able to produce a tone, may be placed a stretched membrane,

for instance, the membrane of a drum, which produces a tone when struck. The vibrations which are caused in it are transversal, and its action may be represented by supposing each diameter of a circular membrane to vibrate as if it were a wire. An essential part of the drum is the cylindrical-shaped volume of air enclosed in it, which considerably increases the intensity of the sound by resonance, if its fundamental tone corresponds with that of the membrane. A membrane stretched over a ring without the drum gives a tone of very moderate intensity.

The tympanic membrane of the ear is not made to vibrate by an impulse derived from solid bodies, but from the sound-waves of the air. The action here takes place in the reverse direction to that of the drum. In the latter case the drum-stick causes the skin of the drum to vibrate, and the skin transmits the vibration to the enclosed air, and, at the same time, to the surrounding air. In the ear, on the contrary, the sound-waves strike against the stretched membrane, which in turn strikes against a very ingeniously formed drum-stick, the *ear-bones*, which transmit the vibrations further.

The manner in which the ear-bones perform their vibrations in conjunction with the tympanic membrane and the membrane of the fenestra ovalis is highly interesting. As to the tympanic membrane, we can have no doubt that, owing to its power of dilatation it can only perform transverse vibrations, since it is set in motion by the sound-waves. The vibrations of the tympanic membrane, as we shall see, are not really so simple as those of a freely-stretched, even membrane; still they agree in form upon the whole.

Further, the ear-bones are solid bodies, partly irregu-

lar, partly of a rod-like form, and their vibrations must be assumed to be very irregular also. A rod fixed at one end can, as we know, produce transverse vibrations, if the free end is drawn aside and suddenly let loose. It can also produce longitudinal vibrations, if it is rubbed in a longitudinal direction. Now it has been observed that solid bodies are very good conductors of sound. If, for instance, we place our ear upon a horizontal trunk of a tree or upon a wall, and strike a distant point of it gently, then we shall hear the sound distinctly, although through the air we can hear nothing at all. Moreover it is known that we can hear the distant tramp of horses much more distinctly through the medium of the earth than through the air. All sound-vibrations which are conducted by solid bodies are, for the most part, longitudinal vibrations. The entire mass of the tree, for instance, does not vibrate first to one side and then to the other; it does not bend to and fro like a firmly fixed pen in vibration, but the vibration takes place in its particles, which, for the most part, move to and fro in a longitudinal direction. Real longitudinal vibrations of the particles are only produced by the friction of thin rods in a longitudinal direction.

We can now imagine the existence of such longitudinal vibrations in the substance of the ear-bones, for bone is a very good conductor of that class of vibrations, as we have already observed, when treating of the conveyance of sound to the ear through the bone. This idea has found many supporters, although the ear-bones, as Helmholtz maintains, are of so small a size compared with the length of a sound-wave, that this action is quite out of the question. The average wave-length

of the medium tones in the air varies from one-half to a whole metre (20 to 40 inches), while in solid bodies it is still greater, since they transmit sound with greater rapidity. Moreover, the ear-bones are by no means immovably fixed, and from their small mass are light, so that an impulse acting upon one end of them must set the whole chain of bones in motion. When, therefore, a sound-wave acts upon the hammer, it is improbable that the motion should be transmitted to the stirrup, like a wave through the heavy trunk of a tree, for a sound-wave is so long that all parts of the three bones must lie upon a single point of the entire wave almost simultaneously, and it must therefore produce a general movement in the same direction.

We must return, therefore, to the only possible conclusion, that the ear-bones vibrate in a transverse direction, and a closer examination of the manner in which they are connected will show us how this is produced.

The handle of the hammer is attached to the tympanic membrane throughout its entire length, whilst its head projects above the edge of the membrane into the tympanic cavity. The neck of the hammer, its long and short processes, are fastened by elastic ligaments, which form an axis round which the hammer vibrates to and fro. This axis passes inwards through the neck of the hammer, and is distinguished in fig. 66 by the point *a*. All the points of the hammer, which are situated below the axis, upon a vibration inwards of the tympanic membrane, will be driven inwards, while all the points which lie above the point *a* will be driven outwards, as is shown by the arrows. Now, whilst the handle of the hammer vibrates inwards, and its head outwards, the anvil will be

set in motion by its articulation with the hammer-head, indeed just as if the joint formed quite a solid connection. The latter is of a peculiar form, which, from Helmholtz's researches, may be compared in the mechanical action to toothed-wheels. These work so closely into each other, that the body of the anvil moves with the hammer-head ; the long process, however, swings upwards and inwards in the same direction as the hammer-handle. This gives,

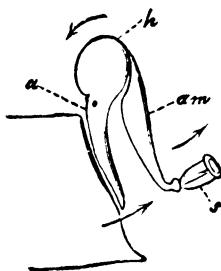

Fig. 66.

as we see, an impulse inwards to the stirrup also, whose foot-plate strikes against the fenestra ovalis, and by this means the sound-wave finds its entrance to the labyrinth.

It is evident that in the backward swing all movements must follow in the reverse direction. We have only to mention that the teeth of the hammer and anvil-joint work into each other. When, therefore, under certain circumstances—for instance, a strong pressure of air in the tympanic cavity—the membrane is pressed outwards, it communicates this motion to the hammer-handle, the hammer-head is moved forcibly inwards, and the articulated surfaces separate, which prevents the stirrup from being detached from the fenestra ovalis.

The system of the ear-bones, therefore, performs a

simultaneous motion round a common axis. Such a motion may be compared to that of a lever ; indeed we have here to do with a two-armed lever, such as the bent lever used in bell-work, in order to pull the wire in a different direction. One arm of the lever, upon which the power of the vibrating tympanic membrane acts, is the hammer-handle ; the other is the hammer-head, with the anvil and the stirrup, which set the entire labyrinthine fluid in vibration.

The vibrations of the ear-bones are therefore, in reality, transversal, although they are in no way analogous to the vibrations of a stretched cord, or a fixed pen ; for the ear-bones are by no means firmly fixed, and do not vibrate by reason of their elasticity. but resemble very light and movable little levers, which are set in simultaneous motion by the vibration of the tympanic membrane.

In a human ear which has been dissected it has also been observed that the ear-bones do really vibrate in the above manner. If a small bright point in them is observed under the microscope, while a sounding organ-pipe is connected with the auditory canal, it appears to be elongated in the direction of the motion into a small bright streak.

The ear-bones, as we have seen, act as a lever which connects the tympanic membrane and the fenestra ovalis, and transfers the force from the former to the latter. While they are set in motion by the membrane, they strike like drum-sticks against the membrane of the fenestra ovalis, only with this difference, that they are as firmly attached to this membrane as they are to the tympanic membrane, and cannot be detached from it.

CHAPTER IV.

The Function of the Tympanic Membrane—The Telephon—Flame Manometer—The Importance of the Funnel-shaped Form of the Ear—The Muscles in the Tympanic Cavity.

IF we strike a membrane, which is stretched over the mouth of a tube or a ring, a tone is produced—its fundamental tone—which increases in acuteness with the tension of the membrane, and diminishes with an increase in the size of the membrane. If we sound the same tone in the neighbourhood of the membrane, which may be done most simply with the voice, the membrane is set in vibration, just as a window-pane rattles when its fundamental tone is sounded loudly. If, however, a different tone is sounded, the membrane is unaffected, and only when we approach its fundamental tone is it set in vibration, or in other words, the *resonance* begins to increase in strength. The resonance of such a membrane may very readily be recognised by strewing upon it some fine sand, which is thrown into a dancing motion by the vibrations.

It might be supposed that the tympanic membrane also possessed such a fundamental tone. It would, however, be very injurious to our hearing, especially to our

perception of music, if the tympanic membrane behaved like an evenly stretched membrane. For, in this case, we should hear the fundamental tone of our tympanic membrane sounding with great intensity, and other tones with rapidly decreasing intensity, so that we should only hear the greater number of tones very faintly.

Thus the tympanic membrane, as we learn from experiment, has the very remarkable property of answering equally well to tones of any pitch, in the range of tones perceptible to our ear, of about 60 to 4,000 vibrations a second, which is impossible with an ordinary stretched membrane.

There are some artificial means by which membranes can be made to vibrate with a large series of tones, and which therefore show some similarity with the tympanic membrane. We have here to mention a very interesting instrument, the *Telephon* of Reiss. It is able to transmit tones by telegraphic means, so that we are able to telegraph a melody quite correctly. The construction is as follows:—A box, A (fig. 67), has a tube, R, through which we can sing into the box. On the cover there is a membrane made of dry bladder, which has only a slight tension, and which, on that account, has a very deep fundamental tone. At one spot there is a strip of sheet tin which extends from the edge to the middle, where a light metallic plate, P, rests upon it, which leads to the conducting wire *d*. On the other side a wire leads to the battery, B, and from the battery another wire leads to the apparatus K, which can be placed at a distance. This apparatus consists of a sounding-box K, in which a thin electro-magnet, E, lies surrounded by a coil of wire, through which the

current passes. Such an electro-magnet has the property of producing tones, the pitch of which depends upon the number of currents which follow each other with extraordinary rapidity. The number of vibrations of the tone is then equal to the number of currents transmitted.

When we sing into the box *A*, the membrane is set in vibration. The little plate, *P*, dances up and down on

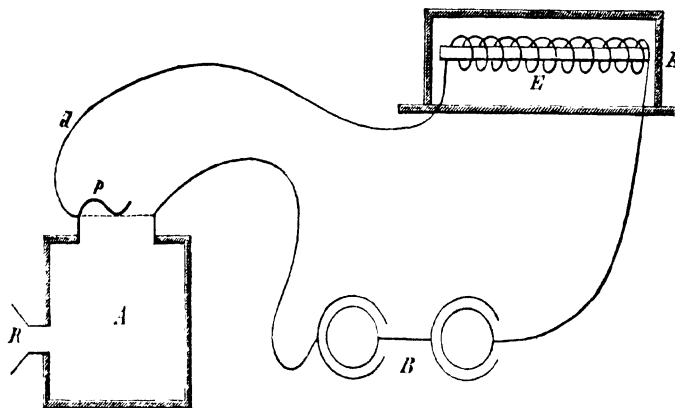

Fig. 67.

the strip of tin, and, therefore, contact is made and broken just as many times in a second as the tone sung makes vibrations. This produces exactly the same number of currents of brief duration in a second, and the electro-magnet gives the tone sung, which is strengthened by the sounding-box.

Now this apparatus works tolerably well within the compass of an ordinary voice ; the membrane, therefore, vibrates with a large number of tones, similarly to our tympanic membrane. This is explained by the fact

that the membrane is not stretched quite equally, and that it possesses a very deep fundamental tone. The result of this is, that the membrane is set in motion by the vibrations of the air in the box A in separate parts, since it is divided into many vibrating portions, and forms the so-called nodal lines, which divide the vibrating portions from each other. With tones, then, of different pitch, differently shaped portions of the membrane will vibrate. Moreover, the metal plate, P, influences the action by loading the membrane. It deadens every vibration peculiar to the membrane, and, of course, every subsequent vibration, though it is light enough to be set in sympathetic vibration by a tone when it is loudly sung. The consequence of this is that the membrane accommodates itself perfectly to a great variety of tones. We are quite justified in comparing it to the tympanic membrane, and the little metallic plate to the ear-bones.

Another ingenious contrivance, which also resembles the action of the auditory apparatus, is the *Flame Manometer* of König.

On the side of a box, K (fig. 68), a membrane of india-rubber, M, is fitted, over which a funnel-shaped tube is fixed, which is left out in the figure. Coal gas is passed into the box, and burns above in the flame, *f*. The membrane, which at first is quite loose, bulges out slightly from the pressure of the gas; so that it is not tightly stretched and has a very low and scarcely perceptible fundamental tone. It vibrates, therefore, with a tolerably large number of tones which can be sung into the tube, and the gas, which is thereby set in vibration, causes the flame to vibrate also. This takes place with

such rapidity that it is imperceptible to ordinary observation. However, a cube with four reflecting surfaces set in rapid rotation makes it perceptible.

Now when the flame burns steadily and we do not sing into the tube, a bright straight line is seen on the reflector. As soon, however, as a tone is sounded, a number of distinct points of flame are seen, while the flame itself flickers up and down, each flicker producing

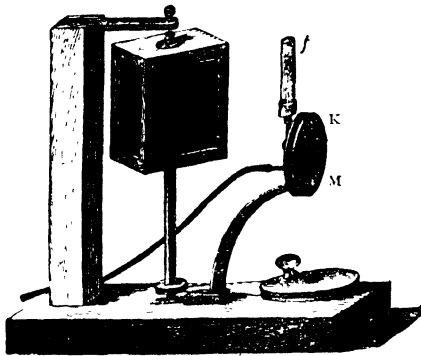

Fig. 68.

a momentary image. The higher the tone, the closer are the images; the lower the tone, the further will they be separated from each other; since the number of images of the flame depend upon the number of vibrations of the tone.

Here, also, we have a membrane which resembles the tympanic membrane in its properties, for it is able to take up the vibrations of tones of different pitch, which is explained by its having a very low fundamental tone. Moreover, the gas here takes part in the action, by loading

the membrane with its pressure, and, at the same time, deadening its fundamental vibration.

Now it is quite certain that the tympanic membrane possesses similar properties, such as would enable it to take up the vibrations of such a large scale of tones.

This property is communicated to the tympanic membrane in two ways ; first, by its *funnel-shaped form*, whereby it is unequally and only slightly stretched ; secondly, by its being *loaded* with the chain of ear-bones.

It has been proved by Helmholtz that a membrane of such a funnel-shaped form possesses remarkable properties.

If we stretch a piece of sheet india-rubber over a wide tube, and press it with a rod in the centre perpendicularly inwards, it then forms a funnel-shaped surface. Moreover, we notice that its surface is curved from within outwards. Now this membrane is in a different state of tension at different distances from the centre, and its tension increases towards the centre. This is recognised from the membrane being more strongly compressed and being thinner at the middle, and because when the tension becomes excessive the centre gives way first.

Such a membrane, however, has no fundamental tone since its tension is not equal. The tympanic membrane also has, in principle, the same form, since from the centre it radiates from within outwards in a convex form. It follows, therefore, that the tympanic membrane is not very extensible, and its tension is just sufficient to draw it slightly inwards from the centre, without its being able to produce any audible fundamental tone. Now such a membrane is extremely well adapted to transmit vibra-

tions of different rapidity, which has been experimentally proved by Helmholtz as follows:—In fig. 69, upon a board, *A A*, is fixed horizontally a tube, *R*, over which a funnel-shaped membrane of bladder, *M*, is fastened to a wooden peg, *S t*, and unites the centre of the membrane with the stretched string, *s*. If a violin bow is drawn across the string it gives a very full tone, since the membrane transmits the vibration very readily to the air. If we remove the peg, however, the string produces a soft, weak

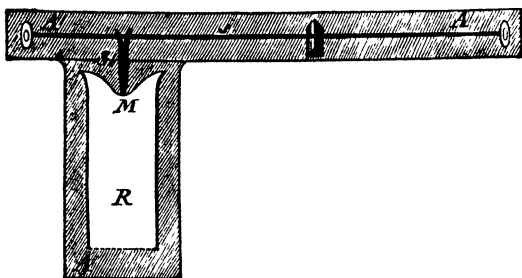

Fig. 69.

tone, since its vibrations are transmitted to the air with difficulty. Moreover, if we hold before the tube, *R*, a tuning-fork, the tone of which corresponds with that of the string, then the string is thrown into rapid sympathetic vibration, which can readily be recognised, because small pieces of paper placed upon the string are dislodged. Since this experiment succeeds equally well with different tuning-forks, as long as we make the length of the string correspond with the pitch of the tone, it follows that the funnel-shaped membrane has the power of transmitting a large series of tones with equal facility. The tympanic membrane, however, which possesses this

power in the highest degree, likewise derives it chiefly from its funnel-shaped form.

Whilst, in the experiment described, we compare the tympanic membrane with the curved membrane, we can compare the peg and the string with the ear-bones, which serve to convey the sound still further. They, however, play another part, in loading the vibrating membrane as an inert mass, and thus deprive it of every trace of its fundamental tone, so that it can accommodate itself equally well to vibrations of every degree of rapidity. Another advantage consists in the fact that the loading of the membrane removes every subsequent vibration of the membrane. It would be exceedingly troublesome to the ear if the membrane continued vibrating, like a drum after it has been struck. This evil is removed chiefly by the ear-bones acting as dampers, like the dampers in a pianoforte, which fall on the wires after every note.

Another important effect which is due to the funnel-shaped form of the tympanic membrane must be mentioned. We have said above that the apex of the funnel bulges inwards like a sail, and consequently the point where the vibrations are greatest cannot be the apex of the funnel, but must be situated somewhere between the apex and the edge. But the force of all these vibrations passes from all sides towards the centre, and produces here, at this point, vibrations of greater intensity. This action may be compared to the wave-motion which we can produce on a loosely stretched horizontal wire. If we strike its lower side upwards from below, a wave then passes along it to the end, where it can spend its strength. In a similar manner the waves of the membrane pass to the centre, and since their force is em-

ployed in setting the chain of ear-bones in motion, the excursions decrease in height. This diminution of the excursions is of great importance ; for it is evident that the membrane of the fenestra ovalis cannot execute such large vibrations as the tympanic membrane, since it is twenty times less. On these grounds the vibrations of the tympanic membrane decrease in the membrane itself, during their passage towards the centre and the point of the hammer-handle. At the same time this causes an increase in the force of the sound-waves in the funnel of the tympanic membrane, just as the rapidity of a stream of liquid increases as it passes down a funnel.

In this manner the sound-waves are transferred from the tympanic membrane to a membrane twenty times less; by the ear-bones the entire force of the vibration of the tympanic membrane is concentrated upon a much smaller surface, and its intensity thereby increased twenty times. Moreover, the chain of the ear-bones acts as a lever ; and when both arms of the lever are fully extended, we then find that the arm attached to the tympanic membrane is half as long again as the arm attached to the membrane of the fenestra ovalis, and, therefore, the force of the sound-waves at the fenestra ovalis is increased thirty-fold. In a consideration of the wonderful delicacy with which the apparatus of the tympanic cavity is constructed, we must not omit the action of two small muscles, which are attached to the ear-bones. One of them is united by a long thin fibre to the handle of the hammer, near the neck (fig. 64), so that it pulls perpendicularly to the tympanic membrane. There can be no doubt that the contraction of this muscle is intended to draw the tympanic

membrane more or less inwards, and thus to increase its tension. The question arises, therefore, what function is to be attributed to these muscles?

A greater or less expansion of the tympanic membrane must evidently have an influence upon its vibration. Since its tension is by no means great, an increase in its tension by means of the tensor tympani muscle must have the power of producing considerable changes. It has, therefore, been imagined that the function of this muscle is to adjust the tympanic membrane for tones of different pitch, so that the ear possesses a power of adjustment similar to that of the eye. It might, however, be argued in opposition to this view that it would be impossible for the tension of the muscle to alter with sufficient rapidity to enable us to perceive the great number of consecutive tones in music, which it is really in our power to do. For the contraction of the muscle would, in a shake, for instance, evidently lag behind the tone heard, and soon fall exactly upon the wrong tone. It is improbable, therefore, that this muscle can act continuously, but we may well imagine it to be set in action when the ear is listening attentively to a certain tone of long duration. The greater its contraction, and the greater the tension of the tympanic membrane, the better shall we perceive high tones, while the deep tones will be less intense, so that in this manner an adjustment of the ear can be accomplished.

The function of a damper has also been ascribed to this muscle. When the contraction of the muscle stretches the tympanic membrane strongly inwards, it might be supposed to damp the vibrations of the mem-

brane, just as a vibrating wire is damped when *pressed by the finger. It is, therefore, quite possible that this muscle may be set in action when a very deafening sound reaches the ear, since it diminishes the amplitude of the excursions of the tympanic membrane. At the same time it will press the stirrup more strongly into the fenestra ovalis, and will prevent it from executing vibrations of an excessive amplitude. The damping action will be more active for deep than for high tones, since an increase in the tension of the tympanic membrane increases the pitch of its fundamental tone.

Very violent concussions, the firing of a cannon, for instance, are known to have the power of bursting the tympanic membrane. This muscle cannot afford any protection against such a violent and sudden action, since it cannot contract with sufficient rapidity, although it is possible that in such cases it may modify the after-vibrations of the tympanic membrane, which are not inconsiderable.

The function of the second muscle, the *stapedius*, which is attached to the stirrup, is, as yet, unexplained. It arises from the posterior wall of the tympanic cavity, and is inserted at right angles into the head of the stirrup near its articulation with the anvil-process. It has been supposed that it is intended to act as a damper to the sound-vibrations, since it places the foot-plate of the stirrup obliquely against the fenestra ovalis. This action might also consist in its pulling at right-angles to the movement of the stirrup, and thereby diminishing its excursions. For instance, if to a vibrating spring we attach a thread, which pulls at right angles to the plane of the vibrations, the latter will be checked.

It is a very curious fact that a nerve passes through the tympanic cavity, called by anatomists the *chorda tympani*, which has nothing to do with the hearing at all. It passes out again through a crevice in the bone towards the tongue.

CHAPTER V.

The Labyrinth—The Organs of Corti—The Transmission of Sound in the Labyrinth—Presence of Sympathetic Vibratory Apparatus.

AS we pass to the Labyrinth we penetrate into the deepest and most secret part of the auditory organ, in which the physiological action of hearing takes place. In order to follow correctly the passages of this complicated structure, we will first consider it from the exterior. It is represented, in fig. 70, from different sides, after a drawing by Helmholtz. In fig. A we are looking at the Labyrinth from the left. The oval aperture (fenestra ovalis), Fv, leads into the broad intermediate space which is called the *vestibule*. On both sides of it there are curiously coiled formations; on the one side the *cochlea*, S, and on the other the *semicircular canals*, C. The shape of the cochlea is exactly similar to that of an ordinary snail-shell, and consists of two coils and a half. The vestibule has a second opening, the *circular aperture* (fenestra rotunda), Rc, which is situated at the commencement of the cochlea. Both apertures are covered with a membrane, and open, as already mentioned, into the tympanic cavity. The plate of the stirrup presses against the fenestra ovalis, but the membrane of the circular aperture is free. The outer

wall of the labyrinth consists of bone, and the whole is imbedded in the solid structure of the skull. Within the osseous walls of the cochlea there is a hollow passage, which winds up to the summit. This passage is divided into two canals by a partition-wall of bone, while the partition-wall passes round the axis from the

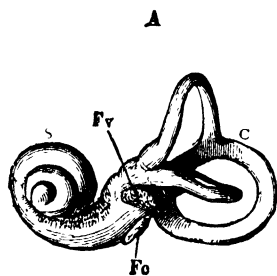

Fig. 70, a.

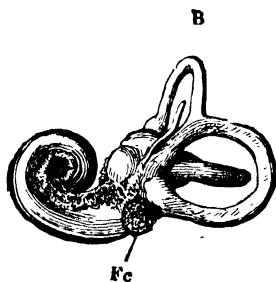

Fig. 70, b.

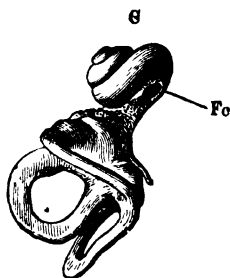

Fig. 70, c.

base to the apex like a spiral staircase. It is called the *osseous lamina spiralis*. However, it does not extend quite to the outer wall of the coils of the cochlea, but is united to it by a membrane, which, from its coiled shape, is called the *spiral membrane*. Of the

two passages of the cochlea which are formed by the lamina spiralis, the one which faces the base of the cochlea is called the *scala tympani*, since it has its commencement at the circular aperture, which leads to the tympanic cavity. The other passage, which faces towards the apex, is called the *scala vestibuli*, and opens directly into the vestibule.

Fig. 71 gives us a section of the cochlea from top to bottom, and also a section of the windings, as well as the partition-wall, which divides them into two passages, the so-called *scalæ*.



Fig. 71.¹

The whole of the interior of the bony labyrinth is covered with a membrane, which is attached to its bony walls, and which is, therefore, called the membranous labyrinth. The whole of the interior is filled with the fluid of the labyrinth, which is intended to transmit the sound-waves. The walls of the vestibule and of the semicircular canals are also covered with this membrane, the whole of which forms two closed sacs, whose sides rest upon the vestibule.

¹ Kölliker, 'Gewebelehre.'

The semicircular canals have a very regular relative position, their planes being at right angles to one another. We distinguish, therefore, one horizontal and two vertical canals, each of which has its origin in an oval dilatation called an *ampulla*.

We find upon the membrane of the membranous labyrinth expansions of the filaments of the auditory nerve, which pierces the bony labyrinth, and is lost in fine terminations; these are distributed in the cochlea, vestibule, and the ampullæ.

Near the wall of the membranous labyrinth are found very small particles called *ear-stones* (otoliths), consisting of carbonate of lime, which have long been known. Max Schultze has lately discovered the existence of terminal nerve-organs in the membranous wall, to which the otoliths appear to be attached. The wall is covered with epithelial cells,¹ which have fine hairs upon their surface, and are connected with the wall by fine nerve-fibres. We may, therefore, assume that when the otoliths are thrown into motion they bend the little hairs backwards and forwards, and thus mechanically excite the nerve-fibres.

The lining membrane in the ampullæ (fig. 72) forms a thick projecting ridge, called the *crista acustica*, which is particularly prominent in fishes. Upon it are found tolerably long, stiff, hair-like processes, which we may also consider as terminal nerve-organs; for numerous nerve-fibres penetrate to the ridge, and are spread out there. These hair-like processes are probably thrown into vibration by the waves of the fluid of the labyrinth, and, thereby, cause a sensation of sound.

¹ Cells which cover the surface of the skin.

Still more remarkable and complicated are the terminal nerve-organs found in the cochlea. The cochlea nerve, which is a branch of the common auditory nerve, pierces the axis of the cochlea and spreads out into

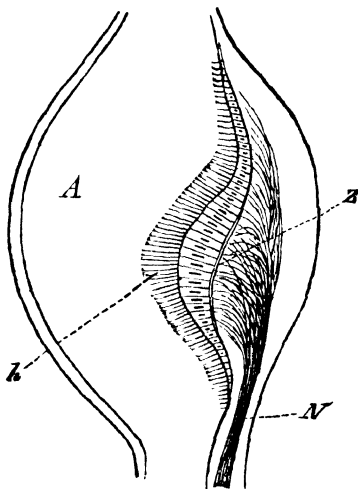

Fig. 72.

fibres, which, by degrees, pass through the osseous lamina spiralis, and at length reach the spiral membrane.

Fig. 73 gives a section through a coil of the cochlea. Upon the right is the outer wall of the coil, and upon the left the axis of the cochlea. The osseous lamina spiralis, *l.s.*, divides the canal into two passages, the *scala vestibuli*, *sv.*, and the *scala tympani*, *st.* The spiral membrane, *b*, joins this partition-wall and shuts off the two *scalæ* entirely from each other, and is attached to the outer wall of the cochlea. A membrane, *v*, further divides the *scala vestibuli* into two longitudinal passages,

The nerve fibres enter the osseous lamina from the axis, pass to its lower edge, where they unite with the spiral membrane. Now this membrane is composed of several

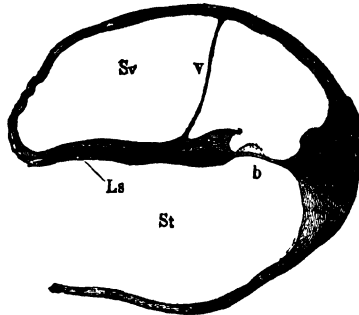
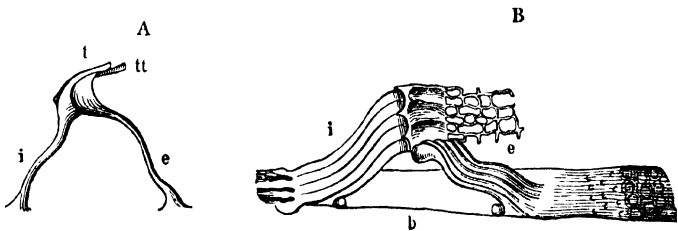

Fig. 73.

formations, some of which are represented by the dotted lines in the figure, and which follow all the spiral windings of the cochlea to the summit. We here have before us the most wonderful formations, the organs which were discovered by Corti, and which bear his name.

Fig. 74.¹

The organs of Corti consist of S-shaped fibres, which may be seen in fig. 74, A. Two fibres are distinguished, an inner *i*, and an outer *e*, which together form

¹ After Helmholtz.

a *bow*. The inner fibre rises almost immediately from the commencement of the membrane, beginning with a broad foot; the outer one terminates in the same manner upon the membrane, which has on that account been called the *basilar membrane*. The fibres are joined

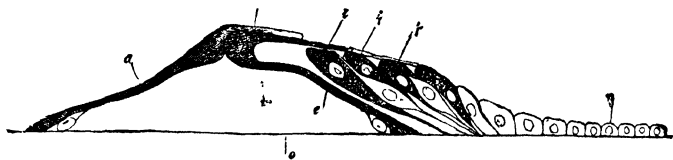

Fig. 75.¹

above in a peculiar manner, *t*, and are prolonged in a short horizontal fibre, *t t*.

Now these fibres of Corti stand in great numbers close together upon the basilar membrane. About 3,000 of the bows have been counted, ranged together in rows in a very small space. Fig. B shows the manner in which the fibres are placed upon the basilar membrane which is represented by *b*. The further discovery has lately been made that the membrane is composed of fibres arranged in a transverse direction, so that every fibre of Corti must rest upon, and pass into one, or a pair of these fibres. This structure is apparently of importance, for it is very probable that the transverse fibres of the basilar membrane are intended to vibrate in common with the fibres of Corti, which rest upon them.

The remaining space between the scalæ is chiefly filled with cells of a different form. The greater number are small oblong cells, provided with a hair-like pro-

¹ After Kölliker.

longation, which are particularly numerous in the neighbourhood of the fibres and the basilar membrane. In fig. 75 we see these cells, *i i*, the prolongations of which pass to the basilar membrane, and which are arranged longitudinally in three rows. The bow of Corti, *a d e*, is here also represented vertical, standing upon the basilar membrane, *o*. The walls of the latter are immediately covered with rounded epithelial cells, *n*.

Viewed from above, the organs of Corti and the accompanying formations present a peculiar structure,

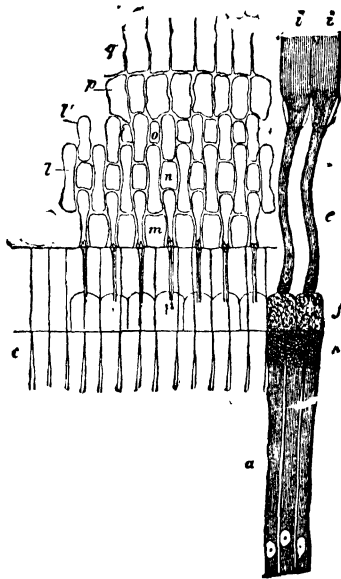

Fig. 76.¹

which recalls the interior of a piano. In fig. 76, we see in *b a c*, the inner fibres of Corti, in *e* the outer, and in *i*

¹ After Kolliker.

their prolongations to the basilar membrane. At *f* is the highest point of the bow formed by the fibres, where the horizontal terminal fibre is found. The cells of the interior are attached to this horizontal fibre like a membrane, and show a very regular formation, which may be seen in fig. 76, where the fibres of Corti have been removed. We here find a threefold row of holes, *m n o*, and between them regularly placed connections, amongst which we discover an inner *l*, and an outer *l'*, and finally square terminal formations, *p q*.

The whole strongly resembles an instrument constructed with great delicacy and regularity, in which the smallest components are fitted with the greatest exact-

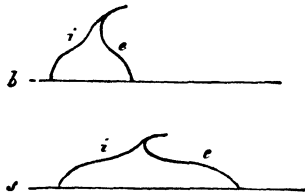

Fig. 77.

ness. In reality we find that the fibres of Corti are not perfectly uniform in size and shape, but that they increase in length and diminish in height from the base to the summit of the cochlea; *i.e.* the short fibres rise more abruptly from the base, as may be seen in the accompanying figure (fig. 77) *b*, while at the summit *s*, they are more elongated and, therefore, not so high, and form a wider arch. The transition from one form to the other is very gradual in the greater number of the fibres. We, therefore, cannot help forming the conclusion that the great number of the different fibres of Corti was intended to render tones of

different pitch accessible to the sense of hearing. Moreover, the width of the basilar membrane is not the same throughout, but increases considerably from the base to the summit of the cochlea, and in a higher degree as the arch of the fibres of Corti increases.

Before we enter upon the functions of the organs of Corti, we must return once more to the transmission of sound-waves to the labyrinth. We left them at the fenestra ovalis, which they had reached through the vibration of the stirrup. The membrane of the fenestra ovalis, therefore, performs transverse vibrations, which set the fluid of the labyrinth in motion. Now it is clear that if the fluid of the labyrinth is here forced inwards, it must give way in another part, for a fluid is not compressible. The circular aperture serves this purpose. As soon as the stirrup vibrates inwards, the membrane of the circular aperture bulges outwards and thus relieves the pressure upon the fluid of the labyrinth. If there were no circular aperture the stirrup could only perform very small vibrations. The circular aperture, therefore, acts as a *counter opening* to the oval aperture.

Now the shock of the stirrup produces a wave in the fluid of the labyrinth, which can be transmitted to all parts of the labyrinth. The wave originates at the oval aperture, and since this leads into the vestibule, the wave first spreads out into the vestibule. From here it passes on into the cochlea, and we must assume that it throws the membranous partition with its organs of Corti into vibration also.

Helmholtz has made some very interesting observations upon this circumstance. Since the vestibule is divided by the two membranous sacs, which it contains

into two portions, each containing fluid, one of which is entered by the oval, the other by the circular aperture, it is impossible that the fluid in the vestibule, by a shock of the stirrup, can uninterruptedly be driven from the oval aperture to the circular aperture. Now the space filled with liquid extends from the oval aperture without interruption to the scala vestibuli of the cochlea, whilst it is prevented from entering the scala tympani by a membrane. The wave will, therefore, chiefly penetrate the scala vestibuli, and flow rapidly up to its head. In this manner it will shake the yielding membranous partition which must give way inwards towards the scala tympani, and thus throw the fluid against the aperture, which is situated opposite to the scala tympani.

We know from the physiological observations upon sympathetic vibrations, that such a condition of things may easily take place, when the fundamental tone of the body performing sympathetic vibrations exactly coincides with that of the sound. Moreover, bodies capable of performing sympathetic vibrations seem really to exist in the organs of Corti. The basilar membrane, which is composed of transverse fibres, we may, after Helmholtz, regard as a series of stretched strings, separate portions of which may be thrown into sympathetic vibration independently of the whole. If we assume, further, that the fibres of Corti, which rest upon the basilar membrane, have an influence upon the fundamental vibration of the membrane, and alter the fundamental tone, according to their height and span, then we can easily understand how each tone will correspond to a certain portion of the basilar membrane at different altitudes between the base and summit of the cochlea.

According to this view, therefore, the whole of the basilar membrane never vibrates to a single tone, but merely a certain portion of it, which renders our power of distinguishing such a large series of tones comprehensible. We are still, however, entirely ignorant of the manner in which the vibrations of the basilar membrane take place, with the fibres of Corti attached to it, which are situated in a soft mass of cells. The inner fibres, which spring from the inner edge of the basilar membrane, can, from their position, be but slightly set in motion, while the outer fibres which rest upon the membrane near its centre, will be very strongly agitated. Still we do not know what part they play in this action; indeed, less importance has lately been ascribed to them than they were formerly supposed to possess, for it has been discovered that in the cochlea of birds the fibres of Corti are absent, and, therefore, more weight has been laid upon the sympathetic vibrations of the basilar membrane.

It is, however, quite certain that, in the cochlea, we have to do with a series of apparatus adapted for performing sympathetic vibrations with wonderful exactness. We have here before us a musical instrument which is designed, not to create musical sounds, but to render them perceptible, and which is similar in construction to artificial musical instruments, but which far surpasses them in the delicacy, as well as the simplicity of its execution. For, while in a piano every string must have a separate hammer by means of which it is sounded, the ear possesses a single hammer of an ingenious form in its ear-bones, which can make every string of the organ of Corti sound separately.

The basilar membrane, as we have already remarked, is not of the same breadth in all its parts, but widens towards its summit. If we suppose it to be rolled out from its spiral form upon a plane, it will have the appearance of a wedge, as the accompanying figure, 78, shows, in which the transverse fibres are represented by lines. Let us suppose the fibres of Corti to be standing upon

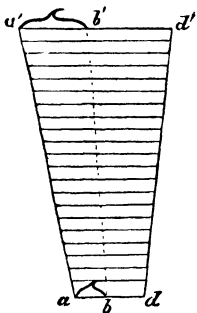

Fig. 78.

the transverse fibres, the span of the fibres of Corti increasing from a to a' , then the first portion of the basilar membrane will gradually increase in breadth from $b d$ to $b' d'$. It seems remarkable that the summit of the cochlea should contain the broad, and the base the narrower portion of the basilar membrane, for we should imagine the opposite to be more practical in the formation of a shell. But all the several parts of this organ

are fitted into each other with such exactness, that this position of the membrane is, doubtless, not without its significance.

From the varying breadth of the membrane and the varying form of the fibres of Corti the conclusion has been drawn, with great probability, that the recognition of high tones takes place at the base of the cochlea and of low tones at the summit; for at the summit the longer fibres will be thrown into vibration by low tones, and at the base the shorter fibres by high tones. To this the objection might be made that the transverse fibres could not be set in sympathetic vibrations by low tones, because they are so exceedingly short. The membrane

indeed is but $\frac{1}{3}$ of a millimetre ($\frac{1}{30}$ of an inch) b. at its point, and hardly $\frac{1}{20}$ of a millimetre ($\frac{1}{200}$ of an inch) at its base,¹ and if we could imagine a violin string as short as this, it would, even with moderate tension, give very high tones; but we must take into consideration the fact, that the transverse fibres are not freely stretched strings, but that they are weighted by the surrounding parts, and that the fibres of Corti, which are connected with them, offer an opposition to the vibrations by their tension. Every such encumbrance and check would, however, lower the fundamental tone of a stretched string and, therefore, it is perfectly comprehensible that the broad portion of the basilar membrane itself might possess deep fundamental tones.

The basilar membrane is not only weighted by the fibres of Corti, but by the entire mass of the cells, which are found upon the fibres and the membrane, and principally by the fluid of the labyrinth; the latter offers a resistance to the vibrations by friction and pressure, and thus it follows that certain fibres of the membrane, in spite of their shortness, are able to vibrate in the same period as the waves of the fluid of the labyrinth itself.

All these observations lead to the conclusion that the cochlea is only designed for the perception of musical sounds. This organ not only enables us to determine the pitch of a tone, but also to recognise tones which follow each other in rapid succession, as when they are arranged so as to produce a melody; and, finally, by the aid of this organ we can even receive the sound produced by a great number of simultaneous tones, so as to enjoy their harmony.

¹ After the measurement of Hensen upon the auditory organ of an infant.

The relation of the number of the fibres of Corti to our power of distinguishing difference in tone has been calculated. We possess 3,000 fibres of Corti, 2,800 of which, according to an estimation by Helmholtz, may be distributed among the 7 octaves which contain the musical notes in general use. Therefore, about 400 fibres of Corti will fall to an octave, and $33\frac{1}{3}$ to every semitone. Thus a considerable number of transverse fibres and fibres of Corti correspond to the interval of a semitone, the middle ones of which will be most strongly agitated, and those on either side in a gradually diminishing degree. However, practised musicians can perceive a much finer difference between two tones, even to $\frac{1}{8}$ th of a tone, according to the assertion of E. H. Weber. Two approximate fibres would exactly coincide with two such tones, and this difference may, therefore, very well reach the limits of our perceptive power. In short, we see how richly the cochlea is provided with sympathetic vibratory apparatus for the perception of musical sensations.

Microscopic Anatomy has lately been engaged with the subject of the connection between the auditory nerve and the organs of Corti. It had already been known for some time, that the auditory nerve penetrates the axis of the cochlea, and that from the axis it gradually distributes its fibres outwards through the osseous lamina. In the latter, the fibres have been traced to the edge where the basilar membrane commences; but, after this point, the course of the fibres can no longer be satisfactorily observed, and great difficulties are placed in the way of further investigation. It is found to be very probable, from the recent very careful observa-

tions of some investigators, that the nerve-fibres are connected with those cells with hair-like prolongations which have been mentioned above. At least, these cells are found in great numbers in the cochlea of birds, in which the fibres of Corti are altogether wanting; and the entrance of fine nerve-fibres into these cells has been observed with some degree of certainty.

It is extremely probable that the extremities of the nerve-fibres are excited by the vibratory apparatus of the cochlea in a mechanical manner, the vibrations of this organ causing them to be stretched or crushed. Every such excitement of an ordinary nerve of the skin would produce a sensation of pain, but the excitement of the auditory nerve calls forth its own specific sensation, the sensation of sound, which is only produced when the nerve has communicated its excitement to the brain. We may assume that each organ of Corti contains, at least, one nerve-fibre, so that the brain is made conscious of tones of different pitch by different nerve-fibres, which accounts for our power of recognising such delicate variations in pitch. We have still to answer the question, as to what significance is to be attached to the otoliths and the hairs in the vestibule and the ampullæ. It is evident that here we have not to deal with various kinds of definite apparatus which can assist us in the sensation of musical sound. It is, therefore, very probable that these organs are only designed for the recognition of noises, by receiving a shock from the irregular unperiodical vibrations of the fluid of the labyrinth, which excites the free terminations of the nerves. In the ampullæ the fluid flows in and out through narrow openings, and here, according to Helmholtz, eddies are probably pro-

duced which throw the hair-like processes into vibration. We must not, however, assume that we are able to recognise a certain tone by means of these organs, because they do not appear to be adapted for different tones; and if they were to possess this power of distinguishing different tones, it would only be in a very imperfect degree. We can, on the contrary, easily imagine that a noise might agitate these organs sufficiently for them to excite the terminations of the nerves in connection with them.

The sympathetic vibratory apparatus in the labyrinth, and particularly in the cochlea, further possess the important property, that they do not continue the vibrations after the sound has ceased, a property which has already been mentioned in connection with the tympanic membrane and the ear-bones. It would, however, be useless in the latter if the organs of Corti did not also possess it. Were they to retain the sound it would be impossible to recognise the shake distinctly, which, however, we can really do to the extent of eight to ten tones a second. Thus after $\frac{1}{8}$ or $\frac{1}{10}$ of a second the tone will have ceased to sound in the ear so completely, that the following tone will not be confused with it. In the piano this property can, we know, only be attained by means of a damper, which falls upon the wire after every blow of the hammer. The portions of the ear, however, which are designed to perform sympathetic vibrations, require no such damper, for they possess from their combination, which, as yet, we do not sufficiently understand, the property of quickly returning to a state of rest when the cause of motion has ceased to act.

Helmholtz has, nevertheless, observed that the ear does perceptibly retain the sound of very low tones. For instance, it is very striking, as pianists know well, that a shake sounds more and more imperfect in the notes below A, because the tones begin to be confused with each other. Now it might be supposed that this is to be accounted for by the imperfection of the dampers of the instrument, and not by any peculiarity of the ear. But in other instruments, the violoncello for instance, in which the finger producing the shake plays the part of an instantaneous damper, and even in a physharmonica, in which the sound ceases the moment the finger is raised, Helmholtz has recognised the same phenomenon. From this we learn that the damping action in the ear is not so perfect for low as for medium and high tones.

This circumstance, moreover, clearly proves, as Helmholtz remarks, the existence of sympathetic vibratory apparatus in the ear, which are adapted for tones of various pitch. For if there were only a single sympathetic vibratory apparatus in the labyrinth, which would answer to all tones, as is the case with the tympanic membrane and the ear-bones, we should find that it would retain the sound in a perfectly different manner. It would then possess a fundamental tone, and as soon as the sound-wave had ceased to act, it would sound, not with the tone of the sound-wave, but, in accordance with certain physical laws, with its own fundamental tone. If, for instance, we move an elastic spring at a rate which does not coincide with its fundamental tone, it will immediately assume the latter when we let it go. Were this the case with the ear, the low tones of the shake would not be confused with each other, but

would be accompanied by a third tone, the fundamental tone of the ear. This, however, is certainly not the case, for no fundamental tone can be recognised in the ear, except that of the auditory canal ; and, therefore, the retention of the sound of low tones can only be caused by certain organs which correspond to those tones, the existence of which is most distinctly betrayed by this peculiarity.

Finally, very interesting observations have been made by Hensen upon the auditory organs of small crabs, which show the sympathetic vibrations of certain organs. These animals possess small sacs which contain ear-stones, and are covered internally with small hair-like processes. Similar hair-like processes are also found upon the surface of the body, upon the antennæ and upon the tail, which are open to direct observation with the microscope. The tone of a horn was conducted to the vessel containing the crabs, which was filled with water, and Hensen distinctly observed the sympathetic vibrations of some of the hairs, and found that they corresponded with tones of different pitch. Hence, it is almost proved to a certainty that the apparatus for producing sympathetic vibrations in the human ear must have a similar action ; only we must remember that, in the latter, the relations are much more complicated, but also that the sensation of musical sound must be much more delicate and perfect than in such crustaceæ.

CHAPTER VI.

The Sensation of Music—The Monochord—The Octave and its Divisions—
Perception of Grave and Acute Tones—The Irritation of the Auditory
Nerve.

A tone is produced as soon as an elastic body performs, with certain rapidity, regular periodical vibrations which are conveyed to the ear by a conductor of sound. We distinguish certain peculiarities in this sensation; in the first place, its strength or intensity; secondly, the pitch of the tone; and thirdly, its colour or quality (timbre).

The intensity of a tone depends entirely upon the extent or amplitude of the sound-wave. If we compare a sound-wave with the waves upon the surface of water, we shall find that, in the latter, the extent is an index of the height, since they increase in power and mechanical action in proportion to their height. And with the amplitude of the vibration of a stretched string, we shall find that the intensity of a tone increases, although the number of vibrations in a second remains the same; and therefore, the further we remove a string from the position it occupies when at rest, the greater will be the intensity of the tone, although its pitch remains unaltered.

The vibrations of elastic bodies, therefore, obey the same rules as the vibrations of a pendulum. A pendu-

lum of a certain length will always make the same number of oscillations in a second, independently of their extent, within certain limits. The velocity of the motion increases with the extent of the oscillations; and the action of a vibrating string is exactly similar.

The vibrations of sound in the air are longitudinal; they consist of alternate expansions and condensations, and the greater the condensation the louder will be the sound produced. The particles of the air execute a motion to and fro, and the greater the extent of this motion the more will they alternately approach and recede from each other; in other words, the greater will be the condensation and expansion which they will produce. The sound-wave itself always retains the same length in the air as was imparted to it by the source of sound. During its propagation through the air the intensity of the tone decreases inversely as the square of the distance, as is the case with light. The reason of this is, that the force of the vibration from a distance I to a distance II will be spread over a surface of four times the size. In every point of the latter, therefore, the intensity will not be in the ratio of $\frac{1}{2}$ but of $(\frac{1}{2})^2 = \frac{1}{4}$.

The pitch of a tone depends upon *the length* of its sound-waves. The longer the sound-wave, the deeper will be the tone, and the shorter the wave, the higher the tone.

To return to the vibrating string, we shall find that the length of the string represents the length of the sonorous vibrations in it. A string of a certain length will, therefore, produce vibrations of half the length of those produced by a string twice as long. Moreover, we know that the first string makes twice as many vibrations in a second

as the latter, and, at the same time, we perceive that the tones produced vary in pitch, one of them being said to be an octave above the other. We can, therefore, say *that the pitch of a tone increases with the number of vibrations performed in a given time.*

Let us consider, further, the sound-waves of different tones in the air, supposing a definite number, which we will call n , of the sound-waves of a tone, to be produced in a certain space round the source of sound. If we now sound the octave of this tone, twice as many, or $2n$ waves will be produced in the same time. Now all sound-waves, whether small or great, are transmitted with nearly the same velocity, therefore $2n$ waves will accomplish the given distance in the same length of time as n waves. In other words, the $2n$ waves will now be contained within this space, each wave being only half the length of the waves of the tone of n vibrations.

When, therefore, we hear two tones, one of which is an octave above the other, the upper tone conveys to the tympanic membrane twice as many sound-waves in a second as the lower one, but of only half the length; and the tympanic membrane and all the sympathetic vibratory apparatus connected with it in the ear, repeat the vibrations in the same length of time. It is very remarkable that our organ of hearing is naturally gifted with a perception of the interval of an octave. Two tones whose rate of vibration is in the ratio $1 : 2$ produce upon the ear a sensation very similar to each other, which is evidently caused by their vibrations standing in such a very simple relation to each other. In spite of this, we are not in the least degree informed by our ear of the existence of the vibrations, and still less of the definite

number which are produced in a certain time', which physical research has first revealed to us. But our sense of hearing is extraordinarily delicate in its power of distinguishing between the pitch of different tones ; that is to say, of distinguishing the relation between the number of the vibrations. We do not, however, recognise them as such, but simply as specific sensations of sound, for it is only through the study of physics that we have learnt to transfer the sensations of tone into relative vibrations.

The great philosopher and mathematician, Pythagoras, who lived in lower Italy 500 years B.C., and by his celebrated teaching laid the foundation of the science of mathematics, was also the discoverer of the law of vibrating strings. He constructed the monochord, which, in fig. 79, is represented in the form now used by Physicists. It is said that Pythagoras was led to the discovery of this law by watching a forge, and listening to the different pitch of the sounds produced by large and small hammers.

The monochord consists of a wooden box so constructed that strings can be stretched across it. The two bridges *a* and *b* fix the length of the string to be set in vibration. The strings are either stretched by a peg, or different degrees of tension may be given to them by weights, the string from the bridge, *a*, being led over a roller and the weights, *p*, hung on to it by a hook. By this means we are enabled to calculate the amount of tension from the weight, and to discover the influence of the tension of the string upon the pitch of the tone.

If we now strike a string of constant tension, or draw the bow across it, a tone of a continuous pitch is heard

which we will suppose to consist of n vibrations. The string, as in fig. 79, consists of sixty divisions, and if we push the bridge up to thirty, then the half-string will produce a tone which will be an octave above the other. If we take $\frac{1}{4}$ of the string, we shall have the second octave; $\frac{1}{8}$, the third; $\frac{1}{16}$, the fourth octave, and so on. Thus we see that the sensation of tone in our ear stands

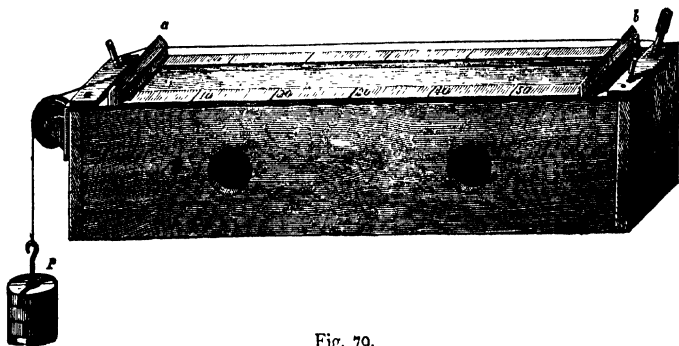

Fig. 79.

in a very remarkable mathematical relation to the length of the string, very simply expressed numerically by the ratio $1 : \frac{1}{2} : \frac{1}{4} : \frac{1}{8} : \frac{1}{16}$, etc.

The power of discriminating tones which the ear possesses is very perfect, a very slight deviation from the octave being recognised as out of tune. We can measure the half of the string with much more certainty by the ear than by the eye, for if we try to touch the half by the eye, we shall find that we generally produce a wrong tone. The violin player, who by pressure alters the length of the strings and, therefore, the pitch of the tone, never calculates the distances with his eye but by means of tactual and muscular sensation, which, with practice, forms a much more certain guide than the eye.

There can be no doubt that this sensation of the octave is a direct gift and innate, without any acquirement on our part. For if an air is sung in a low key to a child, who, as yet, knows nothing of the scale, but has a musical ear, he will afterwards sing the air, in accordance with the capabilities of his voice, an octave higher. Again, we often remark that the uneducated singer, in singing any air, will spring from one octave to another, as it suits his voice.

Two tones, therefore, separated from each other by the interval of one or more octaves, appear, amongst all the other tones, to resemble each other most closely in quality. Now the science of Physics has shown that the number of vibrations varies in a fixed proportion to the length of the vibrating portion of the string. If one string makes n vibrations in a second, then another string of half the length, will in the same time make $2n$ vibrations; and thus we learn that the octave is produced by the conveyance of a double number of vibrations to our ear. It is this very simple ratio of $1 : 2$ between the vibrations which makes it possible for our ear to become conscious of the sensation produced by two very similar tones, and, therefore, we are forced to assume that a pre-established harmony exists in the ear, by means of its internal organisation, which enables it to discover this similarity.

The question, however, with which we are now dealing is not yet exhausted; on the contrary, the puzzle, which Pythagoras proposed 2,500 years ago, was first satisfactorily solved by the researches of Helmholtz. The pre-established harmony which exists between the organisation of our ear and the relative vibrations of tones,

depends entirely upon the existence of sympathetic vibratory organs in the ear, the vibrations of which are regulated by the same laws as those of all elastic bodies. Thus, when we hear two tones at the interval of an octave, two organs (the organs of Corti) vibrate in the labyrinth, the number of whose vibrations coincides with those of the tones, and, therefore, stand in the ratio of 1 : 2.

Two such tones appear to us so exceedingly alike because the second is directly contained in the first and can very easily be produced from it. Let us consider a vibrating string: we can easily divide it, whilst vibrating, into two parts, each of which will vibrate independently, and, on account of their length being half that of the entire string, will perform twice as many vibrations. We

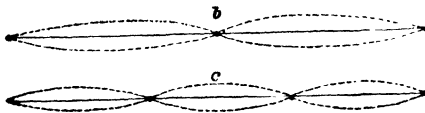

Fig. 80.

shall speak, hereafter, more particularly of this division of the vibrating body, when discussing the production of harmonics, and here will only remark that the octave, so produced, is called the first *harmonic*, or partial tone of the given fundamental tone. Fig. 80 shows how a vibrating string may be divided into two (*b*) or three (*c*) parts, each of which will vibrate independently. In short, starting with the fact that every tone physically contains its octave, it is clear that when we hear a tone we also hear the octave sound more or less loudly; and, therefore, in the labyrinth of the ear, the organs which vibrate in sympathy with this octave will vibrate gently

also. This secondary sound is evidently the cause of the similarity between two tones at the interval of an octave.

The division, therefore, of the whole series of appreciable musical sounds into octaves, is one evidently demanded by nature, with both a physical and physiological foundation. The reason of this will be clearer when we have considered the existence of consonance and dissonance. For the present I will only say that the octave is the most perfect consonance, which arises from the number of its vibrations being in the ratio 1 : 2. We may, therefore, also say that the octave is the interval of the most perfect consonance.

Now the series of sounds within an octave have, in music, been divided into seven intervals, which first gave rise to the term *octave*, it being always composed of these eight sounds. The English signs for them are : C D E F G A B C'. In this scale the interval between E F and B C is about half as great as that between the other notes. The intervals between the latter are, therefore, called whole tones, and those between E F and B C semitones.

Physical science has discovered the ratio of the different number of vibrations for each note in the scale with great exactness, by means of the siren and other instruments. The numbers of vibrations stand in the ratio

$$\begin{array}{l} C : D : E : F : G : A : B : C' \\ \text{of } 1 : \frac{2}{8} : \frac{5}{4} : \frac{4}{3} : \frac{3}{2} : \frac{5}{3} : \frac{15}{8} : 2 \\ \text{or of } 8 : 9 : 10 : 10\frac{2}{3} : 12 : 13\frac{1}{3} : 15 : 16 \end{array}$$

that is to say, while the tone C makes one vibration, D will make $\frac{2}{8}$, E $\frac{5}{4}$, F $\frac{4}{3}$, G $\frac{3}{2}$, A $\frac{5}{3}$, B $\frac{15}{8}$, C' 2 ; or, while C makes eight vibrations, D will make 9, E 10, F $10\frac{2}{3}$, G 12, A $13\frac{1}{3}$, B 15, C' 16. This shows us that the interval

between F and E, which = $10\frac{2}{3} : 10$, is smaller than that between E and D, which = $10 : 9$; also, that the interval between C' and B is smaller than that between the other whole tones (*e.g.* B : A = $15 : 13\frac{1}{3}$). Further, the interval

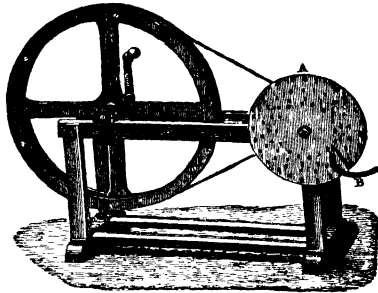

Fig 81.

between the first and the third tone, as that between C and E, is called a third, that between the first and the fourth tone, as from C to F, a fourth, that between five tones, from C to G, a fifth, and so on to the octave from C to C'. We can easily determine by the aid of a siren, which is capable of producing a chord, the ratio of the vibrations given above. Such a siren, which is represented in its simplest form in figs. 58 and 81, has four rows of holes, which, reckoning from the interior, contain 12, 16, 18, 24 holes each. These numbers are in the same ratio as the numbers of the vibrations of C : E : G : C', namely $1 : \frac{4}{3} : \frac{3}{2} : 2$. If, now, we blow upon the rows of holes in succession, the velocity remaining the same, we shall obtain the well-known succession of the tones named. The rows of holes may, of course, equally well only consist of 8, 10, 12, 16 holes, and the same effect be obtained. The siren, represented in fig. 59, could also be made to produce a chord by giving it

more rows of holes, which could be opened and shut at will by a valve. Another apparatus which determines the same ratios is Savart's wheel. It consists of one, or more, toothed wheels, which are made to revolve with great rapidity. If, now, a card is held against the teeth, and the wheel be turned with sufficient velocity, a tone will be produced, the pitch of which depends upon the number of raps given by the teeth. Let us now suppose several toothed wheels to revolve upon the same axis, and that the number of their teeth is in the ratio of 8 : 10 : 12 : 16, we shall then likewise hear the well-known succession of tones C E G C'. By means of the siren and of Savart's wheel the exact number of the vibrations of tones generally used in music can be found, either by direct calculation, or by reading off the number of revolutions in a second by means of clockwork.

Seven octaves are all that are required in music, the lowest of which is represented by *c*, (contra octave), the others by C, C, *c'*, *c''*, *c'''*, *c''''*. It has been decided in Germany to fix the number of vibrations for the tone *a'* at 440 vibrations in a second. The relative numbers of all the vibrations are shown in the following table, given by Helmholtz.

Notes	Contra Octave <i>c</i> —B ₁	Great Octave C—B	Small Octave <i>c</i> —b	Once marked Octave <i>c'</i> —b'	Twice marked Octave <i>c''</i> —b''	Thrice marked Octave <i>c'''</i> —b'''	Fourth marked Octave <i>c''''</i> —b''''
C	33	66	132	264	528	1056	2112
D	37·125	74·25	148·5	297	594	1188	2376
E	41·25	82·5	165	330	660	1320	2640
F	44	88	176	352	704	1408	2816
G	49·5	99	198	396	792	1584	3168
A	55	110	220	440	880	1760	3520
B	61·875	123·75	247·5	495	990	1980	3960

We notice in this table that the numbers within an octave always maintain the same ratio, and that the corresponding numbers in the following octave are always the double of those in the preceding one.

Our pianos generally commence with the *C*, of 33 vibrations, or with a still lower, *A*, = 27·5 vibrations, and extend to *a'''* = 3520 vibrations.

It is of the greatest interest to discover the smallest number of vibrations which is capable of producing the

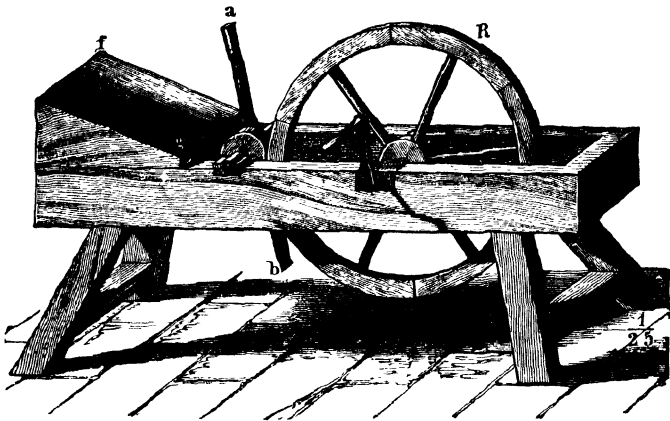

Fig. 82.¹

sensation of a tone. An experiment of this kind has already been made by Savart, by means of the following apparatus. A large wheel is turned by a handle and causes a smaller wheel *r* (fig. 82) to revolve by friction on the periphery. A bar, *a b*, is fixed on the axis of the smaller wheel, and passes through the slit, *c d*, in the board, *f g*. The consequent pulses produce a tone

¹ Mul'et-Pouillet, 'Physik.'

of considerable strength, and Savart affirms that he has even perceived a tone of constant strength with 7-8 pulses. But the musical character of these deep tones up to about 30 vibrations in a second is so extremely imperfect that they are of no use in music. Helmholtz is of the opinion that the deep tones, which Savart heard in his experiments, must have been harmonics of the fundamental tone of 7-8 vibrations. From his experiment with closed organ pipes, which have only very weak harmonics, and with large tuning-forks, the musical character only begins with about 28-30 vibrations. Deeper tones only create a buzzing and groaning sound in the ear.

The combination of the separate vibrations into one tone, is a process which goes on in the nervous apparatus of the ear. We may compare this process to the constant contraction of a muscle, which it is possible to produce by a number of excitements following each other with great rapidity. If, for instance, 8 to 10 electric shocks are directed upon a muscle in a second, the muscle will not relax to its full extent after each shock, and if the rapidity of the shocks is slightly increased, the muscle will remain contracted, as long as the excitement lasts. Now, in the organ of hearing, the auditory nerve is not continuously irritated by the apparatus for performing sympathetic vibrations, but the excitement takes place at short intervals. Our sense of hearing, however, the seat of which must be sought in the brain, combines these rapid irritations of the nerve in the same manner as the muscle, and by this combination the sensation of tone is produced.

An interesting question, also, is to determine what is

the highest perceptible tone. To settle this question Savart has arranged an experiment also by means of a wheel. The toothed wheel B (fig. 83) is made to revolve with great velocity by means of a strap, D, over a large wheel A, so that the teeth strike a card, which is pushed forward upon the plate E. The toothed wheel which Savart used had 720 teeth, and could produce 24,000 raps in a second. The tone thus produced was very weak and acute, but still distinctly audible. Des-

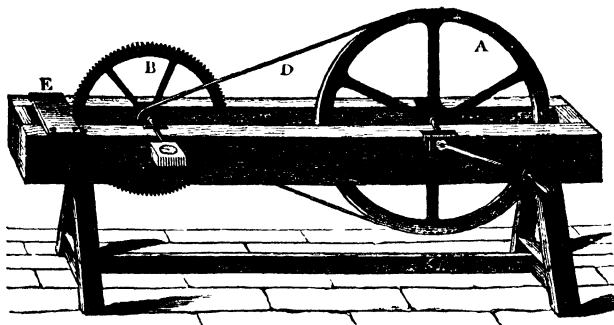

Fig 83.¹

pretz, moreover, has produced with small tuning-forks a tone of 38,016 vibrations; but tones as acute as this are said to be unpleasant and even painful to the ear. We see from these experiments that no fixed limit can be assigned to the perceptibility of acute sounds according to their pitch. This, however, is certain, that above the seventh octave, above the fifth marked c, the tones lose their pleasant musical character, and that the determination of their pitch becomes more uncertain. We may,

¹ Müller-Pouillet, 'Physik.'

therefore, conclude with some certainty that the organ of the ear designed for musical perception is only adapted for seven octaves, and it is this adaptation which we meet with in the organs of Corti in the cochlea.

From what has already been said it appears that the sensation of tone depends upon the repetition of a motion at regular intervals with a certain velocity. A single shock can never produce a tone, so that if only *one* tooth were fixed on Savart's wheel it would be quite impossible to produce a tone, by the wheel striking the card during its revolution ; it has, however, been observed that *two* teeth placed close together are sufficient to produce a tone, and, indeed, the same tone which would be produced by the full number, only with this difference—that it is interrupted by intervals. The reason is clear, for in this case also the interval has remained the same though only created by two shocks. It is, also, an interesting fact that even two irritations of the auditory nerve, if they follow each other in rapid succession, are sufficient to produce a sensation of tone, and that the pitch of the tones entirely depends upon the rapidity with which they follow each other.

In order to understand how it is possible for the auditory nerve to perceive so great a number of different tones, we must once more glance at the organs of Corti, and the distribution of the nerve-fibres there. The nerve, which pierces the axis of the cochlea, spreads out into the finest fibres, each fibre coming in contact with a sympathetic vibratory apparatus, by which it can be irritated. When a certain tone is sounded, the whole of the auditory nerve is by no means irritated, but only

a certain number of fibres which proceed to the organ which is set in vibration.

Our perception, therefore, of tones of different pitch is produced entirely by an irritation of different fibres of the auditory nerve. Through the auditory nerve the brain receives from different fibres an intimation of tones of different pitch, which intimation enables it to distinguish the sympathetic vibratory organs which have answered to the tone. The act of recognition is, indeed, quite unconscious, as are many of the faculties which we have acquired by practice; just as in the movements of our limbs we select the nerves and muscles whose action will perform the purpose which we have in view, without being conscious of the existence of these organs.

The communication of different sensations of tone through the medium of different fibres of the auditory nerve, is a process perfectly analogous to others in the region of the sensory organs. It is due to a property called the specific energy of the sensory nerves, a property which we have already closely examined in connection with the optic nerve. Not only does this nerve answer to every description of irritation, whether caused mechanically, by electricity, or by light, with the sensation of sight; but, as we are forced to assume, it consists of at least three kinds of fibres, each one of which is designed for the reception of one of the three primary colours, red, green, or violet. In the auditory nerve this principle of division of labour is still further developed. In this case each nerve-fibre is connected with one tone of a perfectly distinct pitch and can never render any other tone audible.

We may, therefore, assume that if the separate fibres of the cochlea were to be irritated in any other manner than by sound, as, for instance, by mechanical or electric irritation, their several appropriate tones would be heard. In fact, tones and noises are heard when an electric current is conducted through the head, which are produced by the irritation of the entire auditory nerve. It has been observed, further, that persons suffering from an affection of the ear often experience a constant subjective sensation of a certain tone in the ear, which has been explained as arising from one of the nerve-fibres in the organs of Corti being irritated from some cause due to disease. Indeed, in some diseases, a deafness to a certain series of tones has been noticed which, in such cases, is due to the destruction of certain of the organs of Corti.

CHAPTER VII.

Notes or Compound Tones—The production of **Harmonics**—The perception of the latter by means of **Resonators**—Graphical representation of **Quality or Colour**.

IT is a fact well known from experience, that the tones of different instruments and of the human voice are distinguished from each other by their note or quality. If we sing a tone of a certain pitch, for instance a', strike the same note upon the piano, or if it is sounded upon a violin, a flute, trumpet, or organ, we shall always obtain a tone of the same pitch, making 440 vibrations in a second, and yet these tones differ very widely from each other in their quality.

Into the cause of this we have now to enquire. We must return to the process of vibration to find the principle of this fact. Now, since the tones in the above-mentioned instruments, when they possess the same pitch, invariably possess the same number of vibrations, it is impossible for the number of vibrations to decide the quality of the tone, and we are forced to seek the cause of the difference in quality in some other property of the several vibrations.

Now it is a fact which has long been known to musicians, that a certain number of higher tones are produced

with every tone which is sounded upon our instruments. In acoustics these higher tones have been called the *Harmonics* of the given fundamental tone. If, for instance, the note c is struck upon the piano, an ear musically trained will recognise in this note the c above it. This may be still better accomplished by means of apparatus, of which we shall presently speak more particularly.

The production of these harmonics, which has been investigated by Helmholtz in a very ingenious manner, may be most easily understood from a vibrating string. Let us suppose a stretched string to be thrown into vibration, we shall observe that the essential part of the action consists in the string bending first in one direction and then in the other. The action, however, is in reality not quite so simple as this, but other movements take part in it also. A vibrating string has always a strong inclination to divide into two parts, each of which will perform its own vibrations, as shown in fig. 80 *b*. Thus we can imagine that, whilst the whole string is vibrating, each half is at the same time vibrating independently; and, therefore, in addition to the fundamental tone, a softer tone, the first harmonic, is produced. This must, of course, be the octave of the fundamental tone, since it is produced by the vibrations of the half of the string, the number of which must have been exactly double that of the fundamental note. Therefore, in the same time that the whole string completes one vibration, the two halves will have completed two.

This action is even still further complicated. Not only is the string divided into two halves, but it is at the same time further divided into three equal parts

though in a less degree, as shown in fig. 80 *c*. Each of these three parts, again, vibrates independently, with three times the velocity of the whole string, and by this vibration the second harmonic is produced. If we now imagine these three different vibrations to be combined, we shall have, for every point of the string, a very complicated motion, which, however, we can compose from the separate motions.

But the action has not even reached its limits with the division into three parts, being still further divided into four, five, six, and more parts, and as each of these several parts $\frac{1}{4}$, $\frac{1}{5}$, $\frac{1}{6}$, etc., of the entire length, performs its own vibrations, an entire series of harmonics is produced in accordance with a fixed law. They become weaker and less perceptible as their pitch increases, so that the fundamental tone predominates; but still they give to the fundamental tone a peculiar character: its *quality* or *colour*.

We may easily convince ourselves of the existence of the harmonics in a string, and also determine their pitch, by means of a few experiments. For this purpose we may very well make use of the string of a monochord, but the string of a piano or of a stringed instrument will serve equally well. In the first place we must measure the exact half of the string, which we will suppose to give the tone, *c*. This we shall do most easily by pressing the finger upon the string, and moving it about till the half of the string, when struck, gives the octave, *c'*. Now hold the left forefinger a little distance above the centre, draw the string aside to some distance forcibly with the right hand, and immediately touch the string lightly with the left forefinger. By this means the fundamental

tone, and also a series of harmonics, will be damped, and the first harmonic alone will sound distinctly, because the vibrations of the two halves have not been disturbed. This tone, however, must have existed before the string was touched.

In the same manner we may make the higher harmonics sound distinctly, by laying the finger which acts as the damper upon $\frac{1}{3}$, $\frac{1}{4}$, etc., of the string. The higher they are, the weaker they become.

It is the fundamental tone which determines the pitch of all harmonics. For whilst the fundamental tone makes one vibration, the first harmonic makes two, the second three, the third four, the fourth five, and so on. Thus if the fundamental tone is *c*, the series of harmonics will be : *c'* *g'* *c''* *e''* *g''* *b'''* *c'''*, for while *c* makes one vibration, *c'* performs two, *g'* three, *c''* four, *e''* five, *g'''* six, *b'''* seven, *c'''* eight.

That it is possible for a string to vibrate in such a manner that the two halves, or each third and fourth, will vibrate independently, may be demonstrated by a singular experiment, which every violin player knows from practice. If the finger is laid lightly upon the centre of the string, without pressing it, and the string is then struck, the octave will be heard, with a very delicate quality, called *flageolet*. If a third part of the string is measured off by the touching finger, the fifth of the octave is heard. In this case, not only does the third part of the string vibrate when struck, but each other third vibrates independently, as may be seen in fig. 80 *c*. Now between each of these two thirds there is a point which is at rest ; this may easily be proved in the following manner. If a small piece of paper is placed

that if the string, it will easily be thrown off by the vibrations caused by a stroke of the bow. But if the rider is placed on the intermediate points it will remain undisturbed during the vibrations. This point, which remains at rest, is called a *nodal point*.

If the finger is placed upon the fourth of the string, the second octave is heard when the string is struck. The vibrating string is divided into four equal parts which are separated by three nodal points; and in this manner flageolet-tones of a still higher pitch are produced.

We now know that the series of these flageolet tones exactly correspond with that of the harmonics, since they are produced by dividing the string into parts which correspond with the harmonic numbers. Expressed in notes, the first seven harmonics can be written in the following manner, taking c as the fundamental tone

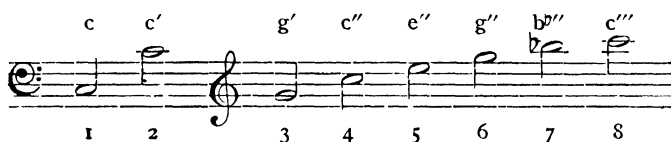

The lower figures show the relative numbers of the vibrations. The intervals between each two consecutive harmonics are as follows: 1—Octave, 2—Fifth, 3—Fourth, 4—Major Third, 5—Minor Third, 6—Augmented Second, etc.

We see how the intervals between these notes gradually decrease in size. The higher the pitch of the harmonics, the more indistinct they become, and the more difficult it is to distinguish them from each other.

It is difficult for an unpractised ear to perceive, and harmonics included in the note. The ear is so accustomed to receive the note as a whole, and the fundamental tone predominates so strongly, that it is difficult for us to withdraw our attention from it. A very important and convenient expedient has, therefore, been invented by Helmholtz, which prevents any uncertainty or deception in the observation of harmonics. He employed for this purpose so-called *resonators*, which are hollow globes, with two openings, as represented in fig. 84. The pointed end of the resonator is applied to the

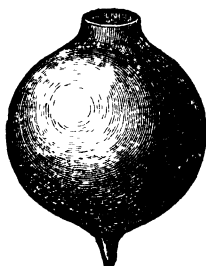

Fig. 84.

ear, and when a note is sounded which accords with the fundamental tone of the globe, it is strengthened. The fundamental tone of each resonator is distinctly defined, like that produced by the wind-chest of every mouth-pipe, or flute, and it may be found by blowing into the globe from the large opening. It is higher if the globe is small, deeper if it is large. When, therefore, this tone is sounded in its neighbourhood, the resonator is thrown into sympathetic vibration, and the tone is strengthened. All other tones, on the contrary, are subdued, a fact which may easily be proved by closing the

at it is shut off every other entrance to the ears of sound, except that through the resonator.

To recognise harmonics in this manner, a whole series of globes of different sizes must be employed. A fundamental tone is then sounded upon an instrument, and those resonators, which respond to the harmonics of the tone sounded, placed near the ear. They will be rendered audible according as they are more or less strengthened by the resonators.

By this means the tones of different instruments, and also of the human voice, have been investigated by Helmholtz. The result of these investigations may be summed up in a few words as follows:—

(1) There is scarcely any musical instrument whose fundamental tone is not accompanied by harmonics

(2) The number and intensity of the harmonics is different in different instruments, *which is the cause of the characteristic quality of each instrument.*

These harmonics are present to a greater or less degree in the sounds produced by all instruments used in music. We have, at present, only considered the production of harmonics in vibrating strings, but every other elastic, vibrating body, shows a greater or less inclination to produce harmonics by the division of its vibrations. This inclination is least displayed by a confined volume of air; when, for instance, we blow into a bottle or a resonator. The vibrations of a tuning-fork approach the simplest form of vibration, since their fundamental tone is only accompanied by very weak harmonics. According to Helmholtz it is possible to produce artificially a tone quite free from harmonics, by fixing a tuning-fork upon a box, which rests upon india-rubber to prevent the

tone being transmitted to the ground, and closed, and before the tuning-fork the opening of a resonator, whose fundamental tone coincides with that of the tuning-fork.

Fig. 85 represents such an apparatus as constructed by Helmholtz. The tuning-fork, *a*, can be thrown into a constant vibration by means of the electro-

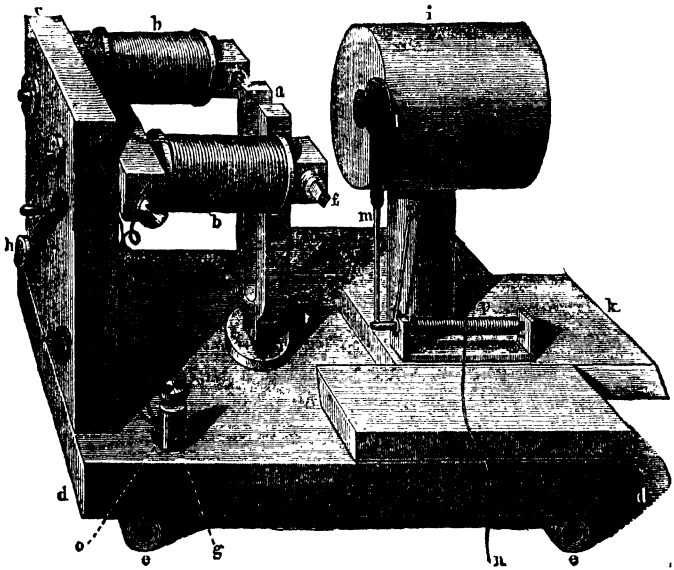

Fig. 85.

magnet, *b b*. The resonator, *i*, is furnished with a flap, *m*, and upon the removal of this flap the tone of the tuning-fork is distinctly heard. We shall presently consider the use of this apparatus more closely.

If we notice the tone of a tuning-fork, or that produced by blowing into a resonator, we shall observe

at it is very pure, but has a *hollow, empty sound*. The tone seems powerless and unsatisfying, and might be said to be devoid of all character. This want evidently proceeds from the absence, or the weakness, of its harmonics. Now it is to the presence of harmonics that the quality of a note is due.

A distinction has, therefore, been made in acoustics between *simple* and *compound tones*, or *notes*. A *simple tone* consists of simple vibrations which do not contain vibrations of harmonics, and whose form coincides with the vibrations of a pendulum. A *compound tone* is a note which, in addition to the fundamental tone, contains a series of harmonics, and which is, therefore, composed of vibrations of a more or less complicated form.

We may obtain a correct idea of the different forms assumed by the vibrations of notes, by using the graphic

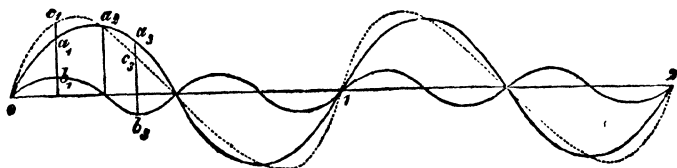

tion, and the length, the duration of a vibration. For it is clear that the wave will increase in height as the vibrations of the fork increase in amplitude; and if the vibrations are slower the waves will become longer and more extended. The tuning-fork completes an entire vibration $o, a_1 a_2 a_3 1$, between the points o and 1 ; one period of the vibration has been accomplished at this point, and now a second portion of the motion, identical with the first, follows from 1 to 2 , in which the direction of the motion is exactly the same. That part of the curve which lies above the abscissa represents the motion in one direction, that which lies below, the motion in the other. Had we been speaking of the sound-waves of the air, we should have termed the upper portion, or the elevation of the wave, a *condensed wave*, and the lower portion, or the depression of the wave, an *expanded wave*. Both together form an entire wave, a complete period of vibration.

A curve of this kind, which is quite symmetrical in form, that is to say, rises and falls with an equal velocity, and in its form represents, according to mathematical calculation, the law of the vibrations of a pendulum, gives us a representation of the vibrations of a simple tone. In an almost similar manner the vibrations of a tuning-fork or a confined volume of air are produced, which, on this account, make such a peculiar impression on our ear.

Let us now consider what changes such a vibration undergoes when accompanied by an harmonic. Let $o, b_1 b_3$ represent the first harmonic of the fundamental tone. It will make two vibrations, while the fundamental tone makes one, and, therefore, two periods are accomplished in the space of time represented by $o 1$. In

order to combine the two tones, we must assume that a point of the vibrating body, as, for instance, the prong of a tuning-fork, is forced to imitate simultaneously the motions of both vibrations. Let us, therefore, suppose that this point has completed the motion as far as a_1 , then it will have been removed a certain distance from the point of rest. This distance is not, however, that from 0 to a_1 , for it must be remembered that, during the production of the curve, the cylinder, upon which it is being depicted, has completed a rotation by the time that the prong of the tuning-fork reaches a_1 . The distance, therefore, of a_1 from the point of rest is represented by the perpendicular line a_1 which, in geometry, is called an *ordinate*.

Now at the moment when the vibration of the fundamental tones reaches a_1 , the vibration of the harmonic reaches its greatest amplitude. The ordinate, b_1 , gives us the height of this amplitude, and, in order to represent the combination of the two vibrations, we have only to add together the two ordinates, a_1 and b_1 , which will give the position of the vibrating point of the combined tone. In this manner we obtain a new form of vibration. The ordinate, c_1 , is here the sum of a_1 and b_1 ; c_3 on the contrary is the difference between the corresponding heights a_3 and b_3 , because a_3 is above the abscissa, and b_3 below it. If, therefore, we add together all those ordinates which are situated upon the same side of the abscissa, and subtract those on opposite sides, and place the sums and differences at their corresponding distances from the abscissa, we shall obtain the dotted curve, which differs considerably in form from the original one. It rises more abruptly at the commencement and attains its

maximum sooner, and then, towards the end, descends in a longer and more gradual slope. The depression of the wave must naturally be symmetrical in form with the elevation.

Thus a perfectly new form of vibration is produced, which, again, makes a particular impression upon our ear. However, the change has not affected the pitch of this combined tone. For it is readily seen that in the time from 0 to 1, a whole period of the new vibration must have been completed. The period of a vibration, and, therefore, the number of vibrations of both tones, is exactly the same, so that the pitch must also have remained the same. But the two notes are different.

We may, therefore, lay down the following law : that *the quality of a note depends upon the form of the sound wave.*

We may imagine other forms of the sound-wave besides that of c , c_3 , which have exactly the same periods of vibration. Let us suppose that, in addition to the first harmonic of the fundamental tone, the second were present also, performing three vibrations in the space between 0 and 1. The form of the new vibration would then evidently be more irregular than before. It might be obtained by combining the ordinates of the vibrations of the third harmonic with the vibrations, c , c_3 . We see that the sums and differences would necessarily always be repeated after each period. The new vibration will, therefore, consist of the same periods and have the same duration. The pitch remains unaltered but the note is again different.

The variety of forms, which a sound-wave can thus assume, is, as we may readily imagine, immense. For

not only is it possible for a still greater number of harmonies to be present, but one or other of the harmonics may be more or less strongly, or only weakly, represented and lastly this or that harmonic may be altogether wanting, so that groups of harmonics of different kinds are associated with the fundamental tone. These variations always give the same pitch, but all give different notes, which are distinctly perceptible to our ear. Thus we may imagine the fundamental tone to be associated with the second and fourth, or the third and fifth harmonics, etc., and in each case the note will be different.

The difference between the notes of our musical instruments may, therefore, be satisfactorily explained by the fact, that the accompanying harmonics give a peculiar form to the original vibration of the tone, which form is different with each instrument. This form of vibration is only recognised by the ear as a whole, and produces in it the sensation of a note. Science has, however, proved the analysis of this whole into the fundamental tone and the harmonics.

CHAPTER VIII.

Analysis of Notes after the Law of Fourier—Helmholtz's Theory of the Perception of Notes—Formation of Notes by Electro-Magnetic Tuning-Forks.

THE observations in the last chapter force the question upon us, whether we are justified in imagining that all periodical sonorous vibrations, which produce a sensation of tone, are formed in such a manner that they may be separated into a fundamental tone and a series of harmonics of different strength.

Let us suppose that we have to do with a very complicated form of sound-wave, for example, that represented in the accompanying fig. 87, which may be drawn quite at will without knowing at all what kind of sound will be produced in our ear. The figure only represents one period of vibration from 0 to 1; the elevation of the wave is quite symmetrical with the depression. It rises rapidly, and, after reaching its maximum, descends somewhat quickly, then for some distance sinks very slowly, falls rapidly once more, and finally, with a gradual inclination, passes into the depression, which is formed in the reverse direction in exactly the same manner as the elevation.

If the wave under consideration is a sound-wave in the air, we may conclude from this form, that the condensation of the air quickly attains its maximum, then

decreases first rapidly, then slowly, then again rapidly, and finally gradually; and that the expansion of the air increases first gradually, then quickly, then again gradually, and, finally, rapidly, to pass once more with great rapidity into the condensation of the second period of vibration. We have to enquire whether it be possible, that such a vibration as this can be composed of a fundamental tone, whose vibrations exactly resemble that of a pendulum, as shown in fig. 86, and of a series of har-

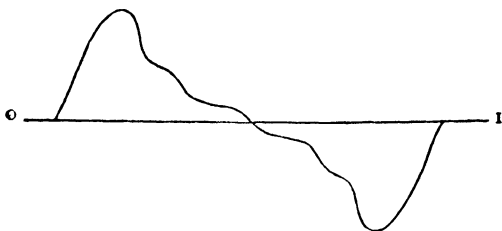

Fig. 87.

monics, each of which, again, has a form of vibration like that of the pendulum, in which the elevations and depressions, in accordance with a fixed law, rise and fall with the same rapidity.

The problem which we have here to solve is evidently a purely mathematical one. In the first place, we must discover whether a simple curve could be drawn upon the axis of the supposed curve of vibration, which would have the same duration of vibration from 0 to 1, and which would correspond to the fundamental tone. We must then try whether the space remaining is sufficient to produce simple curves of half or double, or 3, 4 and 5, etc., times the number of vibrations, which will correspond to the harmonics. We should then, of course,

discover how many such pendulum-curves of greater number of vibrations would be necessary for the purpose ; what number of vibrations they each would have ; and what relation they would bear in pitch, first to each other, and then to the fundamental tone. Finally, the most important point to be observed is, that not a fraction of the surface of the supposed curve of vibration should remain over.

We here have before us a difficult mathematical problem, which fortunately was thoroughly solved by science long before anything was known of harmonics. The distinguished French mathematician Fourier (born 1768) declared :—*That a vibration of any form whatever could be separated into a number of simple curves, if only it were repeated in the same period.*

The proof of this proposition can only be obtained with the help of higher mathematics. We must, therefore, be satisfied with the assurance, that it may be regarded as an incontestable fact, and proceed to consider more closely its application to the theory of notes, for which we have to thank Helmholtz

Fourier's proposition proves a remarkable accordance in the production of harmonics. He shows, namely, that when the number of vibrations of the original vibration is one, the number of the first simple vibration is also one, the second two, the third three, the fourth four, and so on. In short, we see that the first simple vibration is the fundamental tone, and that the others represent the series of harmonics. Whilst, therefore, we have been able above to construct a complicated sonorous vibration from a fundamental tone and its harmonics, we can now, by the help of Fourier's proposition, reverse the method, and

separate the periodical sonorous vibration into a fundamental tone with a series of harmonics.

It is most remarkable that nature is able practically to solve the problem which we have mentioned.

If, when sounding a tone, we place before the ear a resonator, which corresponds to one of the harmonics of the tone, we shall hear the harmonic much more distinctly. An analysis of a peculiar kind has here taken place before the sound-wave penetrates the ear, by which a certain simple vibration has been extracted from the original compound vibration, so that it is conveyed to the ear apart from the rest of the sound. The resonator, therefore, is an analysing apparatus which works entirely in accordance with the principles laid down by Fourier.

We must first consider the action of the internal organs of the ear when a compound note is transmitted to them.

If the tone a' of 440 vibrations is sounded upon a violin and upon a flute, the apparatus of the ear which vibrates in sympathy with tones which perform 440 vibrations in a second, will in both cases be set in motion. Now the question is, whether this sympathetic apparatus first imitates exactly the vibrations of the violin, and then the vibrations of the flute, which must differ from each other; and whether we become acquainted in this manner with the difference in the quality of the notes.

We may assert with confidence that this cannot be the true explanation.

Let us assume the sympathetic apparatus to be in connection with a certain nerve-fibre, which is excited by it. Now we know from what we have learnt of the

action of the nerves, that a nerve will only produce one effect, however it may be excited. If a muscular nerve is excited by chemical, electrical, or mechanical means, the result will always be muscular contraction. The nerve-fibre of the sympathetic apparatus is, therefore, excited twice, without a possibility of the irritation produced being different. It follows, therefore, that the sensation of tone could not be different in the two cases. We are even forced to assume that if a nerve-fibre is excited either chemically, or by electricity, the sensation of tone will be the same. This is further proved by the fact that, sometimes, in cases of an affection of the internal ear, so-called subjective tones are heard, although no sonorous vibrations whatever have taken place. We must assume that in such cases some of the terminal organs of the nerves have been irritated by abnormal excitation.

The sympathetic vibration of a single organ in the ear provided with one, or a certain number of nerve-fibres, can give us no information of the difference between the note of a violin and a flute. A tone of 440 vibrations will, indeed, throw the same organ into sympathetic vibration in both cases; but according to the laws of acoustics, in addition to this organ, others must be set in vibration also, and it is these organs which differ with the harmonics of the tone sounded.

Let us suppose a number of persons, each of whom has provided his ear with a resonator, of which the first corresponds with the fundamental tone of the note sounded on the violin, the second with the first harmonic, the third with the second, and so on, as many resonators as there are perceptible harmonics. Then, if every other

access to the ear is excluded, no one will perceive the note of a violin. Each person only perceives a simple tone, which sounds something like that produced by blowing into a resonator, for the tone of the violin is analysed by the resonator into its elements, each of which is perceived independently. Now let us further imagine these separate sensations to be combined into one, and we shall have a representation of the process which takes place in the perception of a note.

The cochlea of the ear resembles a series of differently toned resonators, an analysing apparatus, which works in strict accordance with Fourier's law, and practically solves the problem in this simple manner. The organ of 440 vibrations selects the fundamental tone, that of 440×2 the first harmonic, that of 440×3 the second, and so on. Further, each sympathetic apparatus vibrates with an intensity corresponding with the intensity of the harmonics of the note produced; and in this manner the whole note is analysed into a number of simple tones, in a manner as perfect as any we can conceive.

After this process of analysis, however, there follows a process of combination, which takes place in other organs. The fundamental tone and each of the harmonics severally irritate a distinct nerve-fibre, and each nerve-fibre transmits its irritation separately to the brain. Here, however, where the mysterious process of sensation takes place, the several sensations are, in an equally incomprehensible manner, combined into a general one, which gives rise to the sensation of a compound tone.

In the representation just given we have entirely followed the theory of Helmholtz, which gives the clearest

explanation of all the facts. We must not forget, however, that the sympathetic vibration of separate apparatus in the cochlea, which corresponds to the different tones, has not, hitherto, been observed directly. And yet this is the only supposition which is necessary for the foundation of the above theory ; but in examining the formation of the organs of Corti the supposition appears to be so extremely probable, that the theory may be regarded as well grounded. We will not, however, omit another experiment by which Helmholtz has considerably strengthened his theory.

If a fundamental tone and an appropriate harmonic produce together a certain compound tone, the combination may take place in different ways. In observing the curves of vibration of both tones, we might assume that both the fundamental tone and the harmonic rise simultaneously at the commencement of an elevation of a wave. After the completion of one period of vibration the same action is repeated, that is to say, the elevation of the second wave is commenced simultaneously by both tones, because the harmonic has always exactly com-

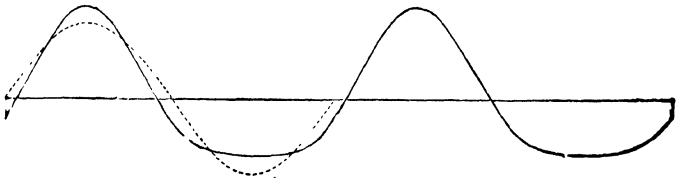

Fig. 68.

pleted a certain number of vibrations when the fundamental tone has completed *one*. We will now alter the

phases, that is, the elevations and depressions of the wave of the harmonic, with respect to those of the fundamental tone, so that the elevation of the wave of the harmonic shall always commence a little after that of the fundamental tone. We shall now be able to see whether the notes produced are different.

In order to make the matter clearer we will employ Helmholtz's figure (fig. 86) in which ~~already observed~~ a note is produced by the fundamental tone and the first harmonic (fig. 86). We will now remove the harmonic such a distance to the right, that its commencement shall exactly coincide with the ordinate, a^1 . From the sum of the ordinates we shall then obtain a curve of vibration, similar to that in fig. 87, in which the elevations are much more abrupt, and the depressions, on the contrary, are broad and flat. The dotted curve represents the fundamental tone.

We might produce a great number of curves which show transitions from one to the other, in a precisely similar manner to that in which we have formed two different curves from the fundamental tone and the first harmonic, by merely displacing the harmonic a little further still. It is quite clear that the waves so produced must differ in form, and the question we have proposed to ourselves is, whether the note is also different.

In order to determine this question by experiment, Helmholtz employed simple tones, which were produced by electro-magnetic tuning-forks, as shown in fig. 85. Let us imagine two such apparatus, one of which gives a fundamental tone, the other a harmonic. If, now, we choose the fundamental tone, B , and the octave, b , as the

harmonic, we shall obtain a note, which is distinctly heard as a deep *oo*.

By means of the following apparatus the phases of the harmonic may be still further removed from those of the fundamental tone. The tuning-fork, *B*, is kept in constant motion by another vibrating tuning-fork, which

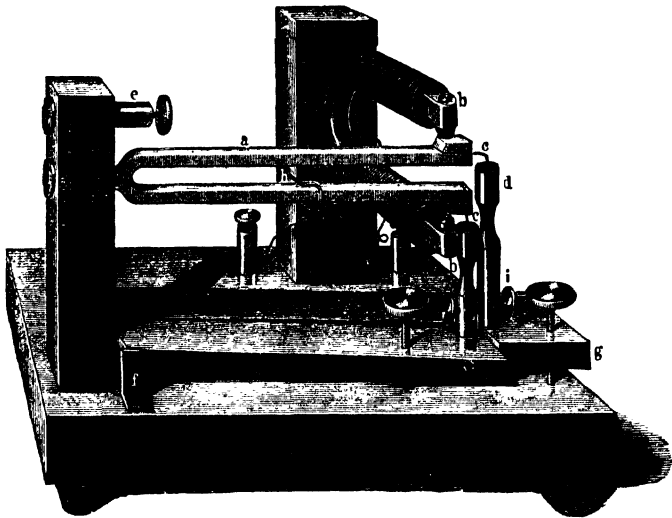

Fig. 89.

latter is represented in fig. 89. We here see a tuning-fork, *a*, the ends of which are placed between the poles of a horse-shoe magnet, *b b*. Upon one or both ends of the tuning-fork there is a hook of platinum, *c*, which dips into a cup of mercury, *d*.

An electric current is now passed from *d* to *e*, through the fork, and from thence through the coils of the horse-shoe magnet. When the prong is raised by the attraction

of the magnet, contact is broken at *c*, since the platinum wire is no longer in contact with the mercury. The fork then returns to its first position, the current is renewed, the fork is again attracted, and is thus kept in constant motion.

The current from the vibrating fork goes from it through the electro-magnet of the tuning-fork, *B*, and throws the fork into unisonant vibration; the current also passes through the magnet of the tuning-fork, *b*, which is also thrown into unisonant vibration, because it receives a magnetic impulse after every two vibrations. The two tuning-forks, *B* and *b*, therefore give a common note *oo*, as soon as the flaps of their resonators are opened.

By such an arrangement the elevations of the waves of the fundamental tone, *B*, and of the harmonic *b*, commence simultaneously, for *b* receives a magnetic impulse in the same direction and at the same moment with *B*. If, however, the opening of the resonator for *b* is a little diminished in size, then, as Helmholtz has shown by calculation, the commencement of the phase is retarded, and the harmonic is removed from the fundamental tone. Nevertheless, in these experiments the note produced by the two tones remains the same, although the elevations and depressions of their waves are not formed simultaneously.

From this important fact we may conclude that the ear does not perceive the different forms of the sound-waves as a whole, but separates them into their simple components.

This fact can only be explained by assuming that the fundamental tone throws one organ into sympathetic vibration, and the harmonic another, so that in this way

the sonorous vibration is analysed into its components. This analysis is always performed in the same manner, however differently the phases of the two tones may be situated. The result must, therefore, consist in the excitement of two nerve-fibres, which in all cases must remain the same, and will, therefore, always produce the same sensation in the ear.

Thus the sensation of a note is caused by *the irritation of a certain fibre of the nerve of the cochlea, which is produced by the fundamental tone, and also by the more or less feeble irritation of certain other nerve-fibres, the terminal organs of which have been irritated by the harmonics*

CHAPTER IX.

Harmony of Notes—Consonance and Dissonance—Production of Beats
 —Dissonance to be attributed to the existence of Beats—Influence of
 Harmonics upon Harmony—Resultant Tones—Chords—Noises.

IN music we not only enjoy the impression produced by a succession of melodious tones, but also experience great pleasure from an agreeable combination of several tones. We are best able to judge of the sensation produced if only two notes are sounded together. The pleasant combinations of tones are termed 'consonance,' and the unpleasant 'dissonance.'

An octave, *c*, and *c'*, will be consonant. Also a fifth, *c* and *g*, and the third, *c* and *e*, is also called consonant. If, however, we strike two approximate notes on the piano, as *c* and *d*, or two which are still nearer, as *c* and *c* sharp, they produce a distinct feeling of an unpleasant sound, which we, therefore, call dissonant. Although there are other intervals which are dissonant besides that between two approximate notes, we will first proceed to examine the approximate notes more closely.

If two tones are dissonant which are separated by the interval of a tone or a semitone, we must suppose that the sensation of dissonance would be increased if the

difference between the pitch of the two notes were still further diminished. This is, in fact, the case. By means of two tuning-forks, which differ but little from each other, we can produce a combination of tones, which will be in the highest degree dissonant. Now, disregarding the æsthetic impression, we make the acoustic observation that the note is produced by separate shocks, which are less frequent the nearer the tones are together. These shocks are called *beats*.

Two approximate tones may be observed to beat with one another in all musical instruments, but most clearly in those in which the pitch of the tone can be easily altered. If we sound the same tone in two open organ pipes, the tone of one may be slightly lowered, by covering part of the upper opening with the hand. The tones will immediately begin to beat, at first slowly, but increasing in velocity as the hand is advanced. If the beats become still quicker, a buzzing, whirring sound is produced. This may be observed upon the piano when two deep tones at the interval of a semitone are struck together.

These beats are no subjective phenomena, but really interfere with, or weaken the tone. They are caused by *interference* of the sound-waves.

By interference of the waves is meant the coincidence of the elevations of one series of waves with the depressions of the other. Whenever this happens the motion of each is arrested, for every depression is filled up by an elevation, and the elevations levelled by the depressions. These interferences may be observed in a tuning-fork, by holding it close to the ear and turning it round on its longitudinal axis. The tone is most intense when

it is held upright, with the two prongs in a straight line with the ear. As soon as the tuning-fork is turned through 45° the tone becomes weaker, but, upon being turned further, again increases in strength. Thus in one revolution the tone is weakened in four symmetrical positions. A series of waves proceeds from each prong which to a certain extent interfere with each other. The prongs vibrate in such a manner, that they both move simultaneously either outwards or inwards. They, therefore, impart to the surrounding air a motion in opposite directions, for when they both vibrate inwards they throw the particles of air, with which they come in contact, against each other, and when they vibrate outwards the particles of air move in the opposite direction.

There is, therefore, one position of the two prongs with regard to the ear, in which an interference of the two series of waves is distinctly perceptible.

If, instead of two perfectly similar series of waves, we have two with unequal periods of vibration, but still very nearly equal, interference will again take place. Let us suppose the first two elevations of a wave to begin at the same time, then the second elevation of the tone, the vibrations of which are slower, will commence a little later, the third twice, and the fourth three times as late, and so on. At length the lower tone will be the length of a whole elevation behind the other, and we shall now have reached a moment when the elevation of one wave will coincide with the depression of the other, and an interference is the result. But this condition is not constant; the waves of the higher tone hasten onwards, so that another moment is soon reached when the elevations of both waves coincide, and the tone is strengthened.

The result of this is, the tone is alternately strengthened and weakened.

The nearer the tones are together, the slower will be the beats, because it will take longer for the higher tone to get an entire elevation in advance of the lower. The greater the interval the more rapid will be the beats, and when the tones are removed a certain distance from each other, the beats will be imperceptible to our ear.

Helmholtz has attributed the cause of dissonance to the existence of beats. The rapid changes in the strength of the tone produced by beats make an unpleasant impression upon the ear, just as the flickering of a light is so extremely troublesome to the eye. When the two tones are very near together, we are conscious of the cause of the unpleasant sensation, because we perceive the beats separately. But at the interval of a semitone or of a whole tone, when we can no longer perceive the beats separately, their presence is only recognised by a feeling of dissonance. Helmholtz shows that the note possesses a certain amount of *roughness* which is produced by the beats.

The unpleasantness in this sensation may be attributed to a perception common to all the regions of nervous activity. Every intermittent excitement of a sensitive nerve-fibre is more tiring than a continuous one. The flickering of a light is so unpleasant because, between every two luminous excitements, the retina increases in sensitiveness, and will be more strongly affected by each excitement. If, on the contrary, the light is continuous, the sensitiveness of the retina becomes gradually blunted, and will be less excited with its duration. In coming out of the dark into a bright light,

we are for a moment quite blinded, because the excitement is here very strong; by the gradual decrease of the excitement the eye becomes accustomed to the light. Flickering may, therefore, be compared to a rapidly repeated transition from darkness to light, and therefore powerfully excites the eye.

The case seems to be the same with the ear, or rather with the auditory nerve. Dissonance is an interrupted note, which excites the ear to an unpleasant degree. A refined musical ear will be extremely sensitive to this excitement, just as the flickering of a light is much more unpleasant to the eye of a sensitive, educated man, than it is to the uneducated.

From the comparison of colours and musical sounds it has become general in common conversation to speak of a harmony in colours, and, therefore, a discordant arrangement of colours has been compared to dissonance. From the stand-point of natural science this comparison is very imperfect. Two discordant colours, such as green and blue, are unpleasant to us because they weaken rather than strengthen each other by both strongly irritating, and therefore fatiguing, the same kind of nerve fibres, whilst yellow and blue appear harmonious because the fibres sensitive to yellow remain at rest while we are looking at the blue colour, and *vice versa*. The common physiological point of comparison between discordant musical sounds and colours therefore consists in the fatiguing of the sensory nerve, which, however, is accomplished in different ways, through an intermittent irritation in the case of the auditory nerve, and in the case of the optic nerve by the irritation being concentrated on a certain kind of nerve.

The number of beats produced by two tones may be determined from the number of their vibrations. If the higher tone makes only *one* vibration in a second more than the deeper tone, then, in this time, it will only happen once that the elevation of one wave will coincide with the depression of another, and if the difference is two vibrations, then it will happen twice, and so on. *In short, the number of beats in a second equals the difference between the number of vibrations.*

The sensation of dissonance reaches its maximum with a certain number of beats. Slow beats between two tones which are very near to each other, since we perceive them as separate pulses, are not so unpleasant to us as the more rapid beats between two tones at the interval of a second or a minor second. If the note b' of 495 vibrations and the following minor second, c'' of 528 vibrations, are struck together, we shall perceive $528 - 495 = 33$ beats, and the dissonance will be very marked and will reach its maximum in this portion of the diatonic scale. If, however, we strike the deep tones, B and C, which make 62 and 66 vibrations, we shall distinctly perceive four beats in a second, and the sensation of dissonance is much less marked. Therefore, the dissonances are not so prominent in the lower as in the middle tones. With the higher tones again the sensation of dissonance, with the same interval, decreases, so that the maximum of dissonance is attained when about 30 beats are produced in a second.

We have, as yet, confined ourselves to attributing the dissonance between two approximate tones to beats. The interval of a second, however, $c-d$, and still more that of a semitone, $c-c$ sharp, are decidedly dissonant ;

but the sound is no longer unpleasant to our ear when the minor third, $c-e$ flat, is struck, which thus represents the transition to consonant intervals.

We must observe, further, that a dissonance may exist between two tones which are situated at a great distance apart. The seventh, $c-b$, is a decided dissonance, almost as decided as the minor second, $b-c'$. The cause of this marked dissonance between c and b cannot lie in the number of beats, for they amount to 115 in a second. We must, therefore, seek another cause for the phenomenon.

Thus, when we reflect that a series of harmonics always belong to the fundamental tone of a note, we may be led to suppose, that the harmonics would also be able to produce beats, which would necessarily have an influence upon the note produced by the combination of the two tones. In fact, in the case of the seventh, $c-b$, the influence of the first harmonic of c , the upper octave c' is perceptible, for between b and c' the roughness of the beats reaches its maximum. Therefore, when two tones are sounded together, we must take into consideration the relation which the harmonics of the lower tone bear to the upper tone, and further, the relation between the harmonics of the lower tone and those of the upper tone.

If the harmonics of both tones coincide we shall have a perfect consonance. This is exactly the case with the octave, as the following example will show.

Fundt. tone.	Harmonics.						
	c'	g'	c''	e''	g''	$b^{b''}$	c'''
	c'	c''	g''	c''	g''	c''	c''

On the left of the perpendicular line are the two fundamental tones c and c' , and their first harmonics follow. We see that every harmonic of c' coincides with a harmonic of c , so that there is here nothing to cause beats. The octave is the most perfect consonance.

The case is similar with the twelfth, $c g'$, which is also called a perfect consonance, as the following table shows :

$$c \mid \begin{array}{c} c' \ g' \ c'' \ e'' \ g'' \ b b'' \ c''' \ d''' \\ \hline g' \mid \quad \quad \quad g'' \quad \quad \quad d''' \end{array}$$

The first harmonic of g' coincides with the fifth of c , and the second with the eighth. The higher the pitch of the harmonics, the less important is their discordance, because they diminish in strength with the height of their pitch. When, however, the first and second harmonics do not coincide, everything depends upon whether or not they together produce a dissonance. For it is this dissonance which they impart to the whole note.

If, therefore, we proceed to analyse the fifth, $c-g$, we shall perceive that the consonance is not nearly so perfect as that of the octave. For the table shows us the following series of harmonics :

$$c \mid \begin{array}{c} c' \ g' \ c'' \ e'' \ g'' \\ \hline g \mid \quad \quad \quad g' \quad d'' \quad g'' \end{array}$$

We here observe that the first and third harmonics of g coincide with the corresponding harmonics of c ; but the second d'' falls between c'' and e'' , and must therefore produce a dissonance. As, however, the dissonance falls between the second and third harmonics, which are not at all powerful, the whole note retains its consonant character, though with a trace of roughness, which gives to the fifth its peculiar character.

The harmonics of the fourth, $c-f$, show the following relation to each other :

$$\begin{array}{c|cccc} c & c & g' & c'' & e'' & g' \\ f & f' & c'' & f'' & a'' & \end{array}$$

Here we see that the first harmonic f' of f does not coincide with any harmonic of c , but must produce a dissonance with g' . The harmonics c'' , however, coincide: the others which follow do not. The fourth, therefore, is not so consonant as the fifth, but still seems pleasant to the ear.

The major third, also, $c-e$, seems to the ear to be a consonance, although the degree of consonance is less than that of the fourth, as the following table will show :

$$\begin{array}{c|cccc} c & c' & g' & c'' & e'' & \dots \\ e & e' & b' & e'' & \dots & \end{array}$$

The third harmonic of e is the first which coincides with a harmonic—the fourth of c . The second b' produces a very marked dissonance with c'' . The first harmonic e' does not form any very decided dissonance with c' and g' .

The major sixth, $c-a$, is similar in form to the major third, as we may easily prove for ourselves. It possesses, also, about the same degree of consonance as the major third.

The minor third already shows the transition to the dissonances, because between the fundamental tones, for example, between c and e flat, the number of beats already begins to be perceptible to the ear. We may, however, designate it as an imperfect consonance, because

the degree of roughness it produces is still not unpleasant to the ear.

The minor sixth, like the minor third, is also an imperfect consonance.

It is, moreover, impossible to draw a well-defined, that is to say, an absolute boundary between dissonances and consonances. It is rather a matter of musical taste, which is subject to variation, as to where we place the boundary. Thus the ancient Greeks and Romans considered the third a dissonance and avoided it in singing, probably because, as Helmholtz supposes, their ear was more sensitive to beats than ours, and because in the deep voices of the men the third would more nearly reach its maximum of roughness, than in the middle tones of our instruments. It was not till the development of concerted instrumental music in the middle ages that the third was admitted to be an imperfect consonance. The seventh, for example, $c-b$, as already explained above, is a marked dissonance because the first harmonic of c only differs from b by a semitone. The first harmonic always has great influence upon the whole note.

Helmholtz has constructed a figure in which the degree of roughness is given for each interval, thirty-three beats per second being taken as the maximum of roughness. The horizontal line $c'-c''$, in fig. 90, represents the diatonic scale between the once and twice marked c ; and let us suppose each note to be sounded with the fundamental tone c' . The roughnesses which arise between these tones and their harmonics are represented by elevations; so that the elevations give the degree of dissonance, whilst the consonances lie in the

depressions. The figures represent the harmonics between which the roughnesses take place, the fundamental tone being marked as 1, and the harmonics with the

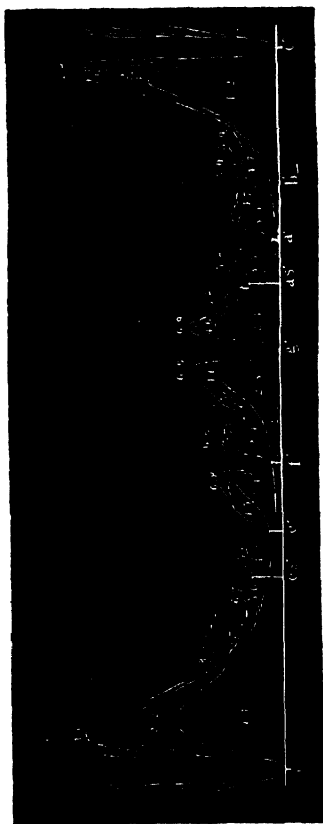

Fig. 90.

1 *c*, *c*' and *b* are the German equivalents for *e* flat, *a* flat, and *b* flat.

following numbers. The octave *c'* lies in the deepest depression, which shows it to be the most perfect consonance, entirely devoid of roughness. If the fifth

g' is sounded with c' , the roughness again is very slight. The depression is not so deep for the fourth f' , and still less for the third e' , and the minor third e' flat. The maxima of the dissonances lie in the proximity of c' and c'' .

It has been observed further, that when two tones are sounded together, tones of an entirely new nature are produced, which have been called *resultant tones*. The lowest resultant tone has long been known; the number of its vibrations equals the difference of the two tones, on which account it is called the *difference tone*. The difference tone for the fifth is the lower octave; so that when, for example, $c' - g'$ is sounded, the lower c is added as a difference tone; for the vibrations of $c : g$ are in the ratio of $2 : 3$, and the difference $3 - 2 = 1$ is the number of vibrations for c .

Besides the difference tone, Helmholtz has pointed out a much weaker *summational tone*, the vibrations of which are produced by the sum of those of the two tones. With the assistance of the resonators, the two tones may readily be distinguished, a proof that they are not, as was formerly supposed, first formed in the ear, but are present in the air. The production of these tones has been referred by Helmholtz, with the aid of mathematical analysis, to the fact that the vibrations of sonorous bodies and the air only partially follow the laws of the pendulum, their deviation from them increasing with the amplitude of the vibrations. Intense and constant notes, like those of an organ, therefore produce intense resultant tones.

Now the resultant tones, also, can give rise to beats, and chiefly because the first harmonic has the power of

assisting in the creation of resultant tones. This, however, is only the case when, as often happens, the deviation of the intervals from their true number of vibrations is at a minimum. If, for example, we take a fifth, the numbers of vibrations of which are in the ratio 200 : 300, the first harmonics will make 400 and 600 vibrations. The fifth itself will give a difference tone of $300 - 200 = 100$ vibrations; the harmonic of 400 vibrations will, with the tone of 300 vibrations also give a difference tone of 100 vibrations. The two difference tones coincide, and therefore give no occasion for beats. If, however, the fifth is a little out of tune so that the numbers of vibrations are, for example, in the ratio 200 : 301, the difference tone would have 101 vibrations. One of the harmonics of 400 vibrations would now form, with the tone of 301, a difference tone of 99 vibrations, and the two difference tones of 99 and 101 vibrations will immediately produce beats.

Altogether, however, the beats caused by resultant tones are less important for consonance and dissonance than the harmonics, because they possess a small amount of intensity.

In concerted vocal and instrumental music we have not only to consider the effect produced by two, but also that produced by several tones, which is commonly called a *chord*. In this case, also, everything depends upon the tones not producing beats together; for if every two tones are consonant, the chord containing all the tones will be consonant also. Thus, for example, the well-known triad, C E G, is a pleasing chord, as are also a number of other chords, with which we have become familiar through musical experience.

A distinction has long been made in music between a major and a minor chord. The triad, C E G, forms the primary chord of the former; the triad, C E flat G, that of the latter. They sound very different to our ear, although their intervals are the same, being changed only in position. For in C E G the minor third, E G, follows the major third, C E, and in C E flat G the major third, E flat G, follows the minor third, C E flat. This difference in the note is very difficult to describe, but is felt distinctly by every ear, and may perhaps be best represented in the following manner: the major chord conveys an impression of clearness, decision, finish, and thus gives rise to a feeling of satisfaction; whilst the minor chord has an undecided, mysterious character, which makes it peculiarly adapted to express sorrowful emotions. The acoustic cause of this difference, as Helmholtz has shown, lies in the relation held by the resultant tones to each other. In the major chord the resultant tones are consonant, whilst in the minor chord the resultant tones produce a dissonance, and thus impart to the chord a strange contradictory sound, which seems to give it its peculiar, undecided character.

The sensation which we call noise is quite different in character from the musical sensation of sound. Noise is produced by irregular, unperiodical movements of those bodies which convey sound. In rubbing two bodies together we obtain a characteristic noise, which arises from shocks experienced by the two surfaces, which, however, do not follow each other at regular intervals of time, and throw the air into irregular vibrations. The shocks will be stronger or weaker according as the

surfaces are rougher or smoother. The sympathetically vibrating apparatus of the ear, the tympanic membrane, the ear-bones, and the fluid of the labyrinth repeat these irregular vibrations and convey them to the auditory nerve. But, in the transition of this movement to the auditory nerve, it is very improbable that the cochlea with its many delicate sympathetically vibrating apparatus, which seem to be adapted to tones of definite pitch, should have the task of taking up irregular vibrations of sound. For an elastic body adapted to a certain tone can only be thrown into sympathetic vibration by tones which approach its fundamental tone. Therefore, even if the labyrinthine fluid in the cochlea were to be thrown into irregular movement, the sensitive organs of the cochlea would be, in proportion, but slightly disturbed from their state of rest. In the vestibule, on the contrary, there are formations to which we might very well ascribe an irregular sympathetic motion, namely, the otoliths, or ear-stones, which are here situated close to the wall of the membranous labyrinth. These little crystals, which are very easily set into motion, cannot possibly act as elastic bodies, cannot possess any vibration proper, and will, therefore, readily perform a sympathetic vibration with a motion of the fluid, however irregular. The nerves in the labyrinth, which are irritated by the otoliths, probably constitute the means by which we are made conscious of noises.

Although we may be justified in assuming that tones and noises are received by different nerves, the problem is still unsolved as to how the nerves are endowed with such different properties. We must here recall to mind similar phenomena in the region of the sensory nerves ;

the specific energy of the optic nerve of producing a sensation of light alone ; that of the auditory nerve of only calling forth a sensation of sound ; and the connection of this with cases in which, within the sphere of a sensory sensation, we discover several qualities of the same sensation.

In conclusion we will remark, that from daily experience we learn to distinguish one noise from another. We therefore call them grating, creaking, hissing noises. Their character depends partly upon the strength of the separate shocks, partly upon the rapidity with which they follow each other, but partly also upon the presence of real tones of various pitch which are intermingled with the noise. Low tones are often connected with a grating noise, and with a hissing noise generally very high tones, which impart to them their peculiar character. It is often by means of this intermixture of tones that we are able to distinguish the cause of the noise.

PART IV.

SMELL AND TASTE.

CHAPTER I.

The Sense of Smell.

CERTAIN substances, in a gaseous form, when inhaled by the nostrils together with the air, create a sensation of smell. The substance smelt here comes into direct contact with the sensory organ, as is the case with taste, and excites it directly in a certain manner, the result of which is an entirely specific sensation of the senses. It would be quite impossible to include the description of the sense of smell with that of the other senses, merely as a species of touch or taste, for it differs from them quite as much as sight and hearing differ from each other, and is a sensation of quite a peculiar kind.

The action of the organ of smell is, therefore, due to a special nerve, the *olfactory nerve*, which differs from the others both in origin, position, and extension. It has its origin in the anterior portion of the cranium in a bulbous swelling, the *olfactory ganglion*, which is strongly developed in the lower animals. Its fibres spread

themselves out in the base of the skull, and force their way through the *cribriform plate* of the cribriform bone, which lies between the sockets of the eyes, by a great number of small apertures into the upper portion of the nose. This part of the nostril is itself divided into three mussel-shaped passages, which are covered by a mucous membrane.

The inferior, and, partly, the middle passage of the nostril serve principally for inhaling and exhaling the air, and are, therefore, called the *respiratory region* (*regio respiratoria*). Like the other air-passages in the wind-pipes and lungs, it is covered with cylindrical cells (epithelial cells) packed closely together, and at their free extremity provided with fine hairs, which, by a sort of waving motion, propel outwards all mucous secretion and dust.

The upper and, partly, the lower passages of the nostril are occupied by the sensory organ for the sensation of smell and have therefore been called the olfactory region (*regio olfactoria*). It is distinguished from the respiratory region by its yellow colour, caused by pigments, and, unlike the latter, is not covered with hairy epithelial cells, but presents a different organisation upon its surface.

The manner in which the olfactory nerve terminates in the mucous membrane of the nostril has only lately been discovered by Max Schultze. The analogy with other sensory organs would lead us to suppose that these nerve-fibres are furnished with peculiar terminal organs, capable of receiving sensory impressions.

The olfactory mucous membrane is also covered with cylindrical epithelial cells, as represented in fig. 91 *e*.

They present their broad end to the surface (*o*), but become attenuated when traced inwards towards the underlying network. Between them we find long rod-like filaments (*s*) which in their lower part swell out into a nut-shaped expansion, and then are prolonged into a fine fibre towards the interior. Now, as this fibre has a great resemblance to the finest nerve-fibres, and loses itself near the terminations of the finest fibres of the olfactory nerve, it very probably has some connection with the olfactory nerve. These formations have been termed by Schultze *olfactory cells*. Very small fine hairs have been observed upon the ends of the small rods in some animals, when the specimens have been perfectly fresh.

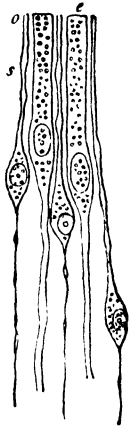

Fig. 91.

The odorous substances, which, together with the air inhaled, are brought into contact with the olfactory mucous membrane, and thus evidently act upon the terminal apparatus of the olfactory nerve, are not, however, directly received by the nerve-fibres, but by the olfactory cells, the fibres themselves very probably not being excited in the slightest degree by the greater number of odorous substances, certainly not by those in a gaseous form. We remember that neither are the optic nerve-fibres affected by the waves of light, nor the auditory nerve-fibres by the waves of sound and shall here find ourselves justified in coming to a similar conclusion.

We must, therefore, suppose that the olfactory nerve would not be conscious of a pleasant odour, if we were to place its ramifications, at the point where they pass

through the cribriform bone, in an atmosphere of Eau de Cologne, nor would it be sensible of an unpleasant odour if we exposed it to an atmosphere of sulphuretted hydrogen. The action of odorous substances consists rather in their producing a change of condition in the terminal apparatus in the mucous membrane, the terminal apparatus then exciting the nerve-fibres whose terminations are situated in close proximity to them. The terminal apparatus alone, and not the nerve-fibres, can receive impressions from an odorous substance, and, as is the case throughout the body, the nerve-fibres serve only to convey the message to the brain that an irritation has taken place.

The substances which we perceive through the organ of smell must be conveyed to the olfactory mucous membrane, together with the inspired air, in a gaseous form ; and since all gases and vapours are more or less soluble in water, they penetrate the moisture of the mucous membrane in small particles. Their influence upon the terminal apparatus of the olfactory nerve with which they come in contact, is very probably of a chemical nature, for the smell of substances differs with their chemical composition. There is, however, a mechanical condition without which we could have no perception of smell—namely, a continual current of air through the nostrils, which is maintained by the process of breathing. If we hold our breath all sensation of smell ceases, even if we are in an atmosphere very strongly impregnated with odorous substances. Again, the sensation is strongest at the moment when we snuff up the air, and we, therefore, repeat it quickly several times in succession when we wish to perceive a delicate odour. The cause

of this is that our nerves are chiefly excited by sudden changes in their condition, not by a permanent condition, as, *e.g.*, by interruptions in an electric current and not by a continuous electric current. This will account for the constant renewal of air in the nostrils being so favourable to the perception of odours, and for the diminution of sensibility when the supply of air diminishes. It therefore follows that a greater number of substances are brought in contact with the olfactory mucous membrane by the current of air.

The amount of a substance which we are enabled to recognise by the organ of smell is extraordinarily small. The merest trace, in a gaseous form, of a drop of Oil of Roses is all that is necessary to produce in our nostrils the impression of a pleasant odour. The smallest particle of musk is sufficient to impart its characteristic smell to our clothes for years, the strongest current of air being insufficient to drive it away ; and Valentin has calculated that we are able to perceive about the $\frac{3}{100,000,000}$ of a grain of musk. The delicacy of our sense of smell thus far surpasses that of the other senses. The minute particles of a substance which we perceive by smell, would be quite imperceptible to our taste, and if they were in a solid form we should never be able to feel them, nor to see them, even if illuminated by the strongest sunlight. No chemical reaction can detect such minute particles of substances as those which we perceive by our sense of smell, and even spectrum analysis, which can recognise $\frac{1}{15,000,000}$ of a grain, is far surpassed in delicacy by our organ of smell.

The development of the sense of smell is even more astonishing in animals than it is in man, and plays a

very important part in their organisation. Hounds will recognise by smell the trace of an animal perfectly imperceptible to sight. But the acuteness of their sense of smell is far surpassed by that of the animal itself, which is able, when the wind is in a favourable direction, to scent the huntsman at a distance of several miles. The number, therefore, of those volatile substances which are perceived by animals at such great distances must be inconceivable. Their minuteness defies estimation.

It is not as yet definitely proved whether animals living in water possess a sense of smell. If we form our conclusion from the development of the organs of smell, it must certainly be decided that they do. For in fishes we find a very strongly developed olfactory nerve, which has its origin in the anterior lobe of the skull, the olfactory plate, and which spreads out in the mucous membrane of the so-called nasal sacs which open out upon the skin of the head. The terminal apparatus of the olfactory nerve in these animals are only affected by substances in a liquid, not in a gaseous, form. Perhaps the process is somewhat similar to that which takes place in the organ of taste, which also can only be affected by liquids. At any rate, the organ of smell in aquatic animals cannot exactly resemble that of air-breathing animals. It is unlikely that a man would be able to smell under water, even if he were able to draw a stream of water through his nostrils without danger to himself. So, at least, an interesting experiment by E. H. Weber would lead us to suppose. The experiment consisted in his filling his nostrils with water strongly impregnated with eau de Cologne. This may be done with perfect ease if the body is placed in a horizontal

position and the head allowed to hang back in a perpendicular position, so that the nostrils point upwards. The velum palati shuts off the cavity of the nose from that of the mouth, so that no water can escape. As long as the water remained in the nose, Weber experienced no trace of a sensation of smell, though he had done so while the water was being poured in. He remarked, further, that every sensation of smell was suspended for several minutes after the water had been allowed to flow out again, which was also the case after the application of pure water. It seems, therefore, as if water, with man, were not a proper medium for the organ of smell.

In all the other sensory organs we have been able to divide the sensations into distinct kinds. But in the organ of smell these sensations are so numerous, that it is almost impossible to classify them. As a general rule we call those odours which are pleasant to us, agreeable smells, and those which are unpleasant, bad smells. Agreeable smells are particularly characteristic of some kinds of ethers and essential oils, which are found in many plants, and are, therefore, used in the preparation of such essences as eau de Cologne. Each of these pleasant smelling substances, moreover, possesses a perfectly distinct smell, which cannot be further defined. When strongly concentrated they sometimes become pungent or overpowering.

In direct opposition to these substances are those which have a bad smell, to which some gases and vapours of simple composition belong. Some of the representatives of this group are sulphuretted hydrogen, phosphuretted hydrogen, arseniuretted hydrogen, bisulphide of carbon, and a number of volatile hydrocarbons. A

great number of compound organic bodies also possess a distinct bad smell. In this group the first place belongs to all those substances which are formed during the decomposition of animal matter.

It is due to a remarkable harmony in our organisation that nearly all substances with a bad smell have an injurious effect upon the body. The gases with a bad smell, such as sulphuretted hydrogen and others, are indeed, powerful poisons, which in large quantities have a fatal effect. Meat, also, which is in a state of decomposition, is repugnant not only to our smell, but to our taste, and, if eaten, may be the cause of dangerous illness. The organ of smell is, therefore, a very important protection to the entire organism, and prevents the entrance of many injurious bodies. It is not every injurious substance, however, that is betrayed by the sense of smell, as, for instance, carbon protoxide, a pernicious gas without smell, which, through carelessness, has been the cause of many accidents.

Many injurious substances cannot be said to have a bad smell, but still, when present in large quantities, their odour is unpleasant, as, for instance, chlorine, bromine, iodine, and ammonia. But, besides the influence exerted upon the sense of smell, we have to take into consideration a general excitement of the entire nasal mucous membrane, which is richly provided with delicate nerve-fibres of the trifacial nerve (N. trigeminus). For instance, the sharp stinging sensation caused by ammonia, is not due to an excitement of the olfactory nerve, but to an excitement of the trigeminus, although the olfactory nerve is strongly irritated at the same time.

It has been observed that those gases are odorous

which have a great tendency to combine, and to react rapidly upon organic tissues. Sulphuretted hydrogen belongs to this class, turning blood black, and decomposing it; and chlorine, iodine, and bromine, which rapidly destroy organic substances, as well as ammonia. In this group we may place also the vapours of alcohol, ether and chloroform, which all act rapidly upon organic tissues.

Those gases, on the contrary, which are not odorous have no chemical action upon organic tissues, or only a very slow one. To this group belong nitrogen, which is quite an indifferent substance, hydrogen and carbonic acid, which can cause no decomposition. But carbon protoxide, which is also devoid of odour, although very poisonous, does not destroy the essential components of the blood, since it can be given out again without the blood having lost its essential properties. Neither does oxygen react rapidly upon animal tissues, and, without taking into consideration slow oxidization, is, therefore, indifferent. Only in its active state, which is called *ozone*, does it ever possess even at ordinary temperatures, a stronger affinity, and it is a rather significant fact, that when in this state it possesses a peculiar odour.

Besides those substances which have an agreeable odour, and those whose odour is unpleasant and bad, there are a vast number of odorous substances, which cannot be classified at all. They may be chemically classified, if we wish to become acquainted with their composition. But the sensations of smell which they excite are specifically different and very characteristic of each substance. We recognise a great number of the

different kinds of meat with perfect ease by their odour, which seems agreeable to us when we are hungry, but disagreeable, and even revolting, when we have appeased our appetite.

Up to the present time science has not been able to offer any explanation of the existence of the different kinds of sensations of smell, or what difference there is between the irritations produced by good and bad smells. From analogy with the kinds of sensation of light, we should be led to suppose, that in the olfactory nerve, there must also be different kinds of terminal apparatus, which transmit the different kinds of smell to those nerve-fibres which are connected with them. But we should have to assume the existence of an exceedingly large, or even infinite, number of such nerves, when we cannot even classify distinctly the different sensations of smell. We must leave all questions upon this subject, which, as yet, is but little understood, for future research to answer.

CHAPTER II.

The Sense of Taste.

ALTHOUGH the sense of taste is most necessary to the enjoyment and welfare of man, science as yet knows but little of its nature with certainty. Even the extent of its diffusion in the cavity of the mouth has not yet been satisfactorily determined. It is, indeed, certain, that the tongue is the principal seat of the organ of taste, and that the sensation of taste is most intense at the back or root of the tongue. The tip of the tongue also possesses a sense of taste, which every one must know from experience. The opinions of the different experimenters are greatly at variance as to the properties of the remaining portions of the surface of the tongue. According to the greater number, the under surface of the tongue possesses no power of taste, or a very dull one, though in most cases the edges of the tongue possess this power. Observations are, however, very difficult to make, and uncertain in their result, because substances placed upon a certain spot of the tongue, will not readily remain isolated, but spread very rapidly, and since the slightest trace is sufficient to be recognised, we are exceedingly liable to deception.

On this account the result of experiments upon the delicacy of the power of taste possessed by the palate is still more doubtful, although it is commonly considered to have an extremely delicate sensation of taste. Many observers assert that the whole of the soft palate and the pillars of the fauces possess a sensation of taste, and yet it has been observed by other careful experimenters that all sensation is wanting when a substance is applied with a pencil upon an isolated point, and every movement of the root of the tongue is carefully avoided. It is possible that this may be caused by individual peculiarities, and that the sensitiveness is more strongly developed in some persons than in others. It seems, in short, only a confirmation of the old saying, 'There is no accounting for taste.'

The anatomical and microscopical investigations of the organ of taste afford a much safer stand-point. The entire surface of the tongue is covered with little elevations called *gustative papillæ*, which are visible to the naked eye. Some of them terminate in a bundle of fibres, and others are broad and bushy on their surface. At the root of the tongue a semicircle is formed by larger papillæ, each of which is surrounded by a circular mound. Small depressions have been observed surrounding these circumvallate papillæ. The papillæ stand in the depressions formed by the mounds, and are filled internally with oblong cells, which are connected by prolongations with nerve-fibres. Similar organs have been observed upon the other papillæ of the mucous membrane of the tongue, and it is probable that in them we must look for the true instruments of taste.

It is not so easy to decide whether there be a special

nerve of taste as was the case with the other senses. There is certainly a nerve, the *glosso-pharyngeal nerve*, which must, without doubt, be regarded as the most important nerve of taste, but its gustative fibres are connected with innumerable motor nerves of the lower part of the head, whilst the optic, auditory, and olfactory nerves are entirely free from any foreign admixture. When this nerve has been severed it has been observed, that animals after this operation will devour food, even when mixed with the bitterest substances, which an animal in a normal condition would refuse to touch.

Besides the nerve named above, another sensory nerve is found in the tongue, the *lingual nerve*, which provides it with the sense of touch and with sensitiveness. It is still uncertain whether it possesses gustative fibres, besides the ordinary sensory fibres. At any rate it can certainly be excited by sapid substances, when they are of a sharp caustic nature, such as strong acids, alkali, strong roots, etc.

One of the qualities of the sensation of taste is, that *sweet* and *bitter* substances seem to produce a distinct sensory impression, apart from any other irritation of the sensory nerves. No concentration, however strong, of these sensations will ever amount to pain, whilst a *sour* taste will produce a contractive and painfully burning feeling. They stand in direct opposition to each other, for the sweet taste appears to us the pleasant, and the bitter taste the unpleasant sensory impression. It is the sweetness of the milk which has such a charm for the infant, and which, when it is hungry, conduces to its reception of nourishment. The bitter and sour taste which we allow to a certain extent in our food, would

be distinctly refused, by the much more sensitive gustatory organs of the infant, as an unpleasant sensation.

The sweet taste is the opposite to the bitter and sour taste, inasmuch as we are able to mitigate the unpleasantness of the two latter by the former, when, for instance, we mix sugar with food which has a bitter or sour taste. Since we thus, as it were, correct the taste without allowing the sugar to react chemically upon the bitter and sour substances, it seems to us that some kind of interference with the sensations must take place for which we can find no explanation. It is also possible for the sweet taste to be combined with the sour and bitter tastes, and produce a pleasant one. But it is well known, on the other hand, that a saline taste is not mitigated by the addition of sugar, and that they never combine so as to produce a pleasant sensation.

The contrast between these sweet and bitter tastes is shown by the following phenomena. After having tasted any bitter or saline substance, pure water, if taken immediately afterwards, will appear to be sweet ; and sometimes a sour taste will remain in the mouth even after we have eaten a large amount of sugar. We cannot help thinking of the great similarity between these phenomena and that of the contrast of colours, but we have as yet no stand-point upon which to follow out such a comparison.

We ought first to enquire what is the cause of the differences in the sensations produced by different gustative irritations, but unfortunately no positive information can be given upon this point. We might, indeed, very well assume the existence of several kinds of nerves with different terminal organs, one producing a

sweet, another a bitter, and a third a sour taste. But science has not yet been able to give sufficient information upon this question by any experiments or observations.

Still less are we able to say why one substance should taste sweet, and another bitter. At least the chemical composition of substances can give no explanation of the fact, for many substances of an entirely different composition, have the same taste. Besides sugar, which is composed of carbon, hydrogen and oxygen, acetate of lead has a sweet taste also. Again, many substances have a bitter taste, such as quinine, sulphate of magnesia, and others, which differ entirely in their composition, and have nothing in common in their chemical characteristics.

A better agreement between taste and chemical properties is shown by the acids and alkalis. There are certain compounds in chemistry, which are distinguished by a sour taste, and are therefore termed *acids*. They have also the property of altering certain colouring matters, *e.g.* turning blue litmus red. In opposition to these acids stand *bases*, and the soluble bases, or alkalis, which are caustic like the acids, and turn reddened litmus blue again. In the combination of acids and bases to form salts, both lose their characteristic peculiarities, and even their peculiar taste, and then have a different one, either a saline taste, as in chloride of sodium, or a bitter taste, as in sulphate of magnesia, or even a sweet one, as in acetate of lead.

The acid, alkaline, and saline tastes belong, generally speaking, to three different series of compounds, which differ from each other by definite chemical characteristics

so that we have some reason for comparing their taste with their chemical properties. But we must add that neither the chemical nor gustative properties of these compounds are separated by sharply defined limits.

It is very remarkable that the acid and alkaline tastes may be artificially induced by an electric current. Let an electric current be passed through the tongue, the positive pole being placed on the tip of the tongue, and the negative pole on the nape, so that the current passes from the tip of the root of the tongue; a *sour* taste will then be experienced on the tip of the tongue. If, however, the negative pole is placed on the tongue, the taste will be different, and is generally described as alkaline. Now we know that the electric current decomposes salts, and that the acids appear at the positive, and the alkalis at the negative pole, and also that salts are found in the saliva of the mouth, which might lead us to suppose that the salts are decomposed at the poles into acid and alkali, both of which we recognise by the sense of taste. But it is not so; for even when the pole is not brought into contact with the tongue, if liquids or the lips intervene, we still experience the electric taste. Now it is possible that the tissue of the tongue itself is decomposed, which causes the taste, but so little is known of these processes, that no satisfactory explanation has at present been offered.

Even weak currents are sufficient to produce the taste, which may most easily be induced by placing polished pieces of zinc and copper upon the tongue, so that the edge of one will touch the tip, the other the under surface of the tongue. If the outer edges are now brought into contact with each other, we experience a

distinct taste, which is acid when the zinc is placed beneath the tongue, and alkaline when the copper is placed on the tip. The moisture of the tongue here forms a weak galvanic element with the two metals.

The sensitiveness of our gustative organs for certain substances is very considerable, but not to be compared with that of smell. We can recognise by taste a solution of one part of sulphuric acid in 1,000 of water. A drop placed upon the tongue would contain about $\frac{1}{2000}$ of a gramme ($=\frac{3}{400}$ of a grain) of sulphuric acid, an infinitesimally small quantity, the detection of which by chemical analysis would be difficult.

In the ordinary course of life we meet with other kinds of tastes in addition to those which we have already mentioned, such as corrupt, rancid, oily, aromatic, and similar tastes. We must remember however, that in such cases, our judgment is seldom founded upon the sensation of taste alone, but is assisted both by the sensation of smell and the sensation of touch. The former is caused by the vapours from the substance which is being eaten, rising through the fauces into the cavities of the nose; and the latter is produced by the form and cohesion of the particular kind of food. The taste or flavour of wine is principally decided by the smell of several kinds of ethers. The potato has no taste of its own, and yet we imagine it to taste differently in different forms. It is clear that in all such cases we experience the combined sensations of smell, taste, and touch.

INDEX.



- Adjustment, 62
Aqueous humour, 52
Arborescent figure, 80
Auditory canal, 185
— — resonance of, 186
Auditory nerve, 224
— — irritation of, 243
- Beats, 253
Binocular vision, 128
Blind spot, 93
- Camera obscura, 55
Chords, 281
Choroid, 49
— notes, 245
— Helmholtz's theory of, 263
Cochlea of the ear, 211
Colour blindness, 114
Colours, 100
— complementary, 108
— harmony of, 122
— sensation of, 109
— Young and Helmholtz's theory of, 113
Colour top, 106
Combination of colours, 106
Common sensations, 4
Consonance, 269
Cornea, 49
Corti, organs of, 215
- Dissonances, 269
Double images, 131
- Ear-bones, 188
Entoptic phenomena, 80
Eustachian tube, 189
Experience, influence upon the senses, 5, 22, 37
- External ear, 180
— world, 5
Eye, the, 48
— defects of; short and long sight; unsymmetrical formation, 72
— illumination of, 82, 85
— motion of, 123
- Far point of the eye, 72
Fenestra ovalis and rotunda, 166, 210, 219
Flame manometer, 201
Fourier's law, 260
- Giddiness, 152
- Harmonics, 235, 246
Harmony, 269
Hearing, organ of, 164
— sense of, 164
Hyaloid membrane, 53
- Incidental images, 116
— — positive and negative, 118
— colours, 120
Interior of the eye, perception of, 78
Intuition, 160
Iris, the, 50, 58
Irradiation of the eye, 77
- Labyrinth, the, 210
— semicircular canals of, 213
Larynx, 176
Lenses, 53
Light, action of, upon the retina, 97
— irritation of, 95
Long-sightedness, 72
Luminosity, 147

- Membrane, vibration of, 198
 Monochord, 232
 Mouth-pipe, 170
 Muscular sense, 40
 — of the muscles of the eye, 129
 — Tensor choroideæ, 67

 Near point of the eye, 70
 Nerves, irritation of, 19
 Noise, 282

 Octave, 231
 Ophthalmoscope, 85
 Optical centre of the eye, 57
 — illusions, 150
 Optometer, 72
 Otoliths, 213

 Pain, sensation of, 14
 Perception of solidity, 130
 Phantoscope, 117
 Pigment of the eye, 50, 83
 Primary colours, 109
 Pseudoscope, 145
 Pupil, 50, 79

 Radiating zonule, 67
 Reed-pipe, 174
 Refraction of light-rays in the eye,
 55
 Resolution of light rays in the eye,
 75
 Resonator, 250
 Resultant tones, 280
 Retina, 51
 — identical points of, 130
 — structure of, 89, 94
 Retinal images, 79

 Scheiner's experiment, 70
 Sclerotic coat of the eye, 49
 Screen, 58
 Sensation, 19
 — after amputation, 22
 — centre of, 4, 34
 Sense of locality, 16
 — of pressure, 13, 40
 — influence of the memory, 42

 Senses, perception of the, 34, 162
 Sensory circles, 27
 — illusions of touch, 36
 — nerves, 1, 2
 — organs, 1
 Short sight, 72
 Sight, sense of, 48
 Siren, 171
 Skin, structure of, 17
 Smell, sense of, 285
 Sonorous vibrations, 167
 — transverse, 170
 — of a string, 231
 Sound, direction of, 182
 — transmission through air, 177
 — — through bones, 188
 Spectacles, 73
 Spectrum, 100
 Stapedius, the, 208
 Stereoscope, 139
 — Brewster's, 140
 — Wheatstone's, 131
 Struggle of the fields of vision, 148

 Tactile corpuscles, 18
 Taste, 295
 Telephon, the, 199
 Telestereoscope, 145
 Temperature, sense of, 13, 43
 Tensor tympani muscle, 207
 Tone, 167
 — deepest, 239
 — highest, 240
 Tones, vibration-numbers of, 238
 — sensation of, 220
 Touch, organ of, 16
 — sense of, 13
 Tuning-fork, 168
 — — electro-magnetic, 251
 Tympanic membrane, 205

 Vitreous humour, 52

 Wax of the ear, 185

 Yellow spot, 89

 Zöllner's figure, 150

