

**PAGES MISSING IN
THIS BOOK
THE BOOK WAS
DRENCHED**

TIGHT BINDING BOOK

UNIVERSAL
LIBRARY

OU **166278**

UNIVERSAL
LIBRARY

OSMANIA UNIVERSITY LIBRARY

Call No. *530*

Accession No. *15156*

C34R

Author *Castelfranchi, gaetano*

Title *Recent advances in atomic*

This book should be returned on or before the date last marked below.

Physics.

RECENT ADVANCES IN ATOMIC PHYSICS

BY
GAETANO CASTELFRANCHI
Professor in the High School for Engineers in Milan

APPROVED TRANSLATION BY
W. S. STILES, Ph.D.
Scientific Assistant, The National Physical Laboratory, Teddington

AND
J. W. T. WALSH, M.A., D.Sc.
Principal Assistant, The National Physical Laboratory, Teddington

Volume I
Atoms, Molecules and Electrons

With 111 Illustrations



LONDON
J. & A. CHURCHILL
40 GLOUCESTER PLACE
PORTMAN SQUARE

1932

Printed in Great Britain

TRANSLATORS' NOTE

IN consultation with the Author, it has been decided to reduce somewhat the bulk of the work by the omission of Chapters IV, VI and XXI of the third Italian edition. These chapters deal respectively with the Brownian Movement, Relativity and Mass, and Astrophysics. In addition, Chapters III and VIII of Vol. II of the English edition have been slightly abridged. The other alterations and rearrangements made are of a very minor character. The opportunity has been taken to correct certain slight errors in the text and to revise the more fundamental data in accordance with the International Critical Tables.

W. S. STILES.

J. W. T. WALSH.

TEDDINGTON.

EXTRACTS FROM THE AUTHOR'S PREFACE TO THE THIRD ITALIAN EDITION

IN this third edition I have endeavoured to make the treatment more precise and more vigorous. I have added certain sections, such as those on piezoelectric quartz, photoelectric cells, the new theory of radioactivity, the discovery of parahydrogen, television, etc. . . . The numerical data have been brought up to date. . . . To enable students to follow out the various subjects in greater detail, an extensive bibliography has been added, both in the body of the text and at the end of each chapter; reference is there made to specialist books which are not always available. To assist in the use of the book, the more difficult paragraphs, which do not form an essential part of the main treatment, have been marked with an asterisk and subsidiary matter is printed in smaller type. The less advanced reader may omit Chapters III, VII, VIII, and IX of Vol. II

THE AUTHOR.

MILAN,

December, 1930.

Isotopes	102
Positive Rays—Use of the Positive Rays as a Method of Chemical Analysis: Aston's Isotopes—Spectrographs of Aston and of Dempster—Bibliography.	
VI. X-rays and the Atomic Number	212
The Discovery of X-rays and X-ray Tubes—Properties of X-rays—The Nature of Röntgen Rays and the Range of Their Wave-lengths—The Diffraction of X-rays by Crystals: Laue's Remarkable Discovery—The Internal Structure of Crystals—Radiographs—Moseley's Discovery—The Continuous Background Spectrum and its Limit—The Use of Gratings in X-ray Spectroscopy—The Absorption of X-rays—Practical Applications of X-rays—Bibliography.	
VII. Crystals	255
The Reflection Method: W. H. Bragg and W. L. Bragg—The Braggs' Spectrometer: Brief Outline of their Work on Crystal Structure—Debye and Scherrer's Method of Crystal Analysis—Piezoelectric Properties of Quartz: Supersonics—Bibliography.	
VIII. Radioactivity	279
Henri Becquerel: Pierre and Marie Curie—The Radiations of Radioactive Bodies—The α -Particles and Methods of Counting Them: Determination of their Charge—Radium Emanation—The Number of the Radioactive Elements and their Threefold Grouping—Radioactive Evolution: The Disintegration Law—Experiment shows that Radioactive Transformations follow the Law of Probability—Determination of Average Life: Radioactive Equilibrium—The Production of Helium: The Heat Liberated—The Discovery of Isotopes—Path of the α -Particles: Geiger's Law—The Path of each Atomic Projectile may be made Visible: Photography of the Trajectories: C. T. R. Wilson—The β -rays, their Velocity and Ionising Power—Radioactive Transformations have Provided Various Methods for Finding Avogadro's Number—Total Energy Liberated from Radium: The Internal Energy of Matter—The Complete Spectrum of the Ether Waves—Bibliography.	

HAP.		PAGE
IX.	The Atomic Nucleus	327
	<p>A Master of Atomic Physics : Rutherford -- The Passage of α-Particles through Atoms—Rutherford's Theory of the Scattering of α-Particles in Passing through Solids—Geiger and Marsden's Measurements : Chadwick's Work at Cambridge—Other Estimates of the Number of External Electrons in the Atom—The Size of the Nucleus—The Nucleus and the Surrounding Electrons—The Various Atoms contain α-Particles—The Artificial Disintegration of the Elements (1919–1923)—Rutherford's Experiment on Artificial Atomic Disintegration—Rutherford and Chadwick's Improvement of their Method—Photographs of the Expulsion of Protons obtained by P. M. S. Blackett (1925) —Bibliography.</p>	

Index.

AUTHOR'S PREFACE TO THE FIRST EDITION

THE first two chapters are introductory, and describe those basic ideas in chemistry, physical optics and the electromagnetic theory of light which are needful to a proper understanding of the remaining chapters.

For the sake of simplicity and brevity, some subjects have been omitted altogether, and in others the treatment has been limited to giving the reader a general idea of what is known. If there are gaps, these are not always unintentional; on the other hand, some repetition has been thought permissible as likely to assist the reader.

In dealing with the principal subjects, each one of which has a separate chapter devoted to it, we have mentioned only the most prominent physicists so as to avoid referring to hundreds of names. At the same time, though the honour of certain theoretical or experimental discoveries may belong chiefly to one man, it is equally true that many others may, by their labours, have prepared the way, may even have reached similar results contemporaneously or have developed and elucidated the work of others.

For such reasons it is sometimes difficult to ascribe names and dates very precisely to the various discoveries; the progress of science is due to contributions made by many workers, and does not take place solely in vast strides due to single individuals.

Many books on modern physics have already achieved a wide circulation even among non-specialists, particularly those dealing with the advances made during the first three decades of the present century; in these books just the outstanding points have been dealt with and at no great length.

In the present work the historical and biographical portion,

although of very great interest, has been almost entirely suppressed for the sake of brevity. We have rigidly adhered to the simplest possible form of treatment, avoiding all that is abstruse, all unnecessary elaborations of the argument, and all lengthy calculations which hinder a rapid comprehension of the subject as a whole by obscuring it in a mass of detail.

THE AUTHOR.

MILAN,
December, 1928.

RECENT ADVANCES IN ATOMIC PHYSICS

VOLUME I

CHAPTER I

ATOMS AND MOLECULES IN PHYSICAL CHEMISTRY

Modern Physics

IN developing the various branches of our subject, the historical order will as far as possible be followed. This has the advantage of showing the remarkable development of physics in the last thirty years, in its successive steps. The most striking advances have been made in the domain of the atomistic, in the world of the infinitely small. Nevertheless, at the other extreme, in the world of the stars, physics has remarkable progress to report. It is noteworthy that the study of atomistic phenomena has placed in our hands the means for investigating the stars, where protons and electrons, the simple fundamental building stones of the universe, play their part just as in some very delicate experiment in the laboratory.

The whole of modern physics is dominated by atomistic ideas. We feel urged towards the ultimate elements which make up matter and energy and which lie at the base of all physical and chemical phenomena, in an attempt to reveal the essence, the *substratum* of nature.

In the last thirty years, an uninterrupted succession of experiments, of discoveries—some accidental—and of theories co-ordinating the experimental data, has so enriched and perfected the atomistic conception that at the present time there can be no one without some knowledge of this doctrine. There are many reasons why this is so. There is the interest which the infinitely minute excites, the close connection of atomic theory with the physics, and chemistry of ordinary materials, the

dramatic crisis which the atomistic conception has precipitated in physics, its mother science, and finally there are the innumerable applications which the new science has found in a thousand directions. It is only necessary to mention among the fields of application of modern atomistic physics, the technique of high vacua, the thermionic valve of wireless telegraphy, cosmogony, X-ray and radiation therapy, meteorology, quantitative spectrum analysis, physiology, television, etc.

Atomistic theory was initiated in about 1860 with Maxwell and Boltzmann's (1844–1906) celebrated kinetic theory of gases. After this first achievement it seemed that no further advance would be possible, but following upon the work of Maxwell (1873) and Hertz (1888) demonstrating the electromagnetic character of light, there came the experiments on cathode rays which revealed the existence of an electrical corpuscle as a universal constituent of matter. In 1895 Lorentz made a direct attack on the problem of the connection between light and matter, and produced his electron theory.

In the same year (1895) Röntgen discovered X-rays and quickly ascertained their nature. Becquerel, H. Curie and Madame Curie discovered the phenomenon of radioactivity (1898). In the following year the existence of electrons as universal constituents of matter was demonstrated.

At this point there begins a veritable revolution in physical science. In 1900 Planck laid the foundations of the quantum theory. Einstein a little later (1905) gave the laws of Brownian motion and of statistical fluctuations, derived the specific heat formula and created the relativity theory which was to overthrow century old notions of space and time, and, in the process, make its author world famous. In 1913 the Braggs' work revealed the structure of crystals. Rutherford (1919) elucidated the nuclear structure of the atom in a long series of experiments. .

Thomson and Aston discovered isotopes. Millikin succeeded in isolating and measuring the electron. Bohr (1921) and Sommerfeld gave the complete theory of the hydrogen atom. Compton (1924) was led to the discovery of the striking effect which now bears his name, by a profound analysis of the nature of

light. Fermi created the new statistics. Uhlenbeck and Goudsmit found spectroscopic evidence for the rotating electron; Pauli revealed the *key* to the periodic system. Louis de Broglie (1925) conceived the idea of wave mechanics. Schrödinger of Zurich (1926-27) and others developed this idea in various directions. Almost at the same time, Heisenberg founded quantum mechanics, Born Gordon and Dirac completing the theory.

Historical Note on Atomistic Doctrine

The genius of the Ionic philosophers seven centuries before Christ, had already divined the existence of the atom. Thales of Miletus, Leucippus, Democritus and Epicurus, taught in Thrace, in the school of natural philosophy, that all bodies are composed of atoms, eternal, invisible, incorruptible, in ceaseless motion. This was twenty-two centuries before the physics of the elements originated with the work of Bacon, Desartes, Boyle and Newton. Chemistry arose later, about 1790, with Lavoisier, Dalton and Avogadro.

The philosophers of Ancient Greece were already deeply immersed in the study of metaphysics, while still ignorant of physics. They discoursed cosmogony before astronomy had laid the solid basis of the science, and aimed at the supreme synthesis of knowledge.

The Middle Ages were a period of black night as far as science in general, and atomistic doctrine in particular were concerned. Even towards the end of the seventeenth century, Leibnitz made fantastic speculations on the constitution of matter, but Pierre Gassendi in France, in about 1650, had already commenced to grasp the true principles underlying the constitution of substances.

It is with Boyle, who died in 1691, that the new historical period in the study of the atomistic doctrine begins, and we have the first glimpses of the true concepts of the corpuscular constitution of matter, and of chemical composition and decomposition. The great Lavoisier, founder of Chemistry, who at the age of fifty-one met a tragic end on the guillotine, bequeathed to Dalton (1766-1844) the task of founding the atomic theory of matter. Dalton discovered the law of multiple proportions, and in 1808 published

a work entitled "A New System of Chemical Philosophy," in which he put forward the principles that elements are composed of similar atoms of constant weight, and that compound substances are composed of the atoms of elements combined in numerically simple proportions.

After Gay-Lussac's Laws given in 1807, followed four years later by Avogadro's hypothesis, the atomic theory underwent a process of completion and perfection, and with Cannizzaro (1826-1910) the period of the determination of the atomic weights was brought to a close.

In about 1900, however, a new horizon in the study of the atom was disclosed. It appeared that the atom was no longer indivisible as implied by the etymology of the name. The electric discharge in vacuum tubes, radioactivity, studies of ionisation, spectrum analysis, X-rays, the theory of quanta and the theory of relativity have in the past thirty years thrown unexpected light on the constitution of matter and of radiation. Sensational discoveries were recorded in every quarter. An innovatory whirlpool enveloped physics, bringing with it a feeling of confusion to the very men to whom the new developments were due. Laws, universally accepted in the old physics, were shown to be invalid in the new.

Atoms, Molecules, Simple Substances

The atom is the smallest portion of a given substance which is met with in chemical processes. The molecule, on the other hand, is the smallest particle for which the distinctive character of a simple or compound chemical substance is conserved. For example, when hydrogen and chlorine unite together to form hydrochloric acid, the *molecules* H_2 and Cl_2 split up into their constituent *atoms* to yield two *molecules* of HCl.

The number of simple substances or elements known at the present time is ninety-two, although not all have been effectively isolated. Two elements have not yet been detected experimentally. On the other hand, the number of different kinds of molecule is practically infinite. We need only mention the countless compounds of carbon.

When hydrogen unites with oxygen to form water vapour, the combination always occurs in the ratio 2 parts by weight of the former to 16 parts by weight of the latter. It would seem in no way unreasonable to us if a substance with properties very similar to those of water could be obtained by the combination of 2.1 gm. of hydrogen with 16 gm. of oxygen. Nature, however, has so disposed that that can never happen, and Proust was able in consequence to enunciate the celebrated law that "the proportion in which two elements unite cannot vary in a continuous fashion."

Hydrogen and oxygen can become associated in another proportion, but then the new compound is totally different from water, and the quantities of the components are in an entirely different ratio. Two grammes of hydrogen combine with 32 gm. of oxygen to yield hydrogen peroxide.

Similarly, chlorine and copper combine to give both cuprous chloride and cupric chloride; carbon and oxygen to give carbon monoxide and carbon dioxide. These provide examples of the well-known phenomenon of valency which we need not dwell upon here.

Dalton discovered the law governing the formation of compounds in this way. He asserted that in all compounds in which two simple substances occur, the quantities of the one, which are found associated with a given quantity of the other, stand in a simple ratio, and this remains true if the compound contains other elements in addition to the two under consideration. For example, in cupric sulphide CuS , in cuprous sulphide Cu_2S , and in cupric sulphate CuSO_4 , copper is combined with sulphur, either in the same ratio or in the double of this ratio.

Dalton (1808) was led to assume that Proust's Law and the law enunciated by himself result from the fact that the elements are formed of isolated, strictly identical, indivisible particles which take part in the chemical processes of synthesis and analysis without being broken up.

These particles, indivisible in all chemical transformations, spontaneous or induced, were rightly to be termed "atoms" in the strict etymological sense of the word.

Thus a single atom of carbon will combine with either one or two atoms of oxygen, giving CO and CO_2 respectively, and a thousand million carbon atoms will combine with precisely one thousand million or precisely two thousand million atoms of oxygen. The laws of Proust and Dalton are both explained by the one hypothesis.

It was realised that the atoms of a given element are all identical one with another, and all have the same weight and character. In combination the atoms group together by whole numbers.

At this stage the determination of the relative atomic weights was possible, but not altogether easy, for the following reason. Consider, for example, the very large number of compounds containing the three elements—hydrogen, oxygen and carbon. Chemical analysis will establish that a gramme of hydrogen combines with m grammes of oxygen and n grammes of carbon in one compound, and p grammes and q grammes respectively in another. How are we to know the number of atoms in the molecules of the different compounds considered? How can we find the atomic weight of carbon and of oxygen with respect to hydrogen if chemical analysis does not furnish an unambiguous method of deciding in which of the molecules being analysed the weights of the constituents stand in the same ratio as the atomic weights? *The relative weights of the atoms could be found by quantitative analysis if we knew how many of them there were in the given molecule.*

Fortunately, other considerations serve to guide us in the choice of the atomic weight, which, from the purely chemical point of view, would remain indeterminate. Two similar compounds give rise to crystals of the same form, so-called isomorphs, as, for example, the chlorides, bromides and iodides of a given metal.

Furthermore, the compounds of a metal with chlorine, bromine and iodine act similarly in chemical reactions. This leads us to believe that the ratios between the weights of chlorine, bromine and iodine in copper chloride, bromide and iodide for example, will be really the ratios of the atomic weights. Thus, the uncertainty in deciding the atomic weights is considerably reduced.

There are innumerable examples of *isomorphism*.

Law of Dulong and Petit (1819)

The specific heat law of Dulong and Petit provides a further means of deciding atomic weights.

According to this rule, if the specific heat of a solid element is multiplied by the atomic weight, we obtain in almost every case the constant value *six*.

The product, specific heat \times atomic weight, is termed the *atomic heat*.

Element.	Specific Heat.	Atomic Weight.	Atomic Heat.
Magnesium . . .	0.250	24.3	6.1
Potassium . . .	0.166	39.1	6.4
Copper	0.095	63.6	6.0
Zinc	0.094	65.4	6.1
Silver	0.057	107.9	6.1
Gold	0.032	197.2	6.3
Sulphur	0.178	32.0	5.7

If there is uncertainty after the examination of the compounds to which gold gives rise, as to whether its atomic weight is 197 or double or half this value, we can select with confidence 197, because the specific heat is 0.032, and $197 \times .032 = 6.3$. Researches subsequent to those of Dulong and Petit have disclosed exceptions to the rule given above. For example, the specific heat of carbon in the form of diamond is 0.143, and its atomic weight equals 12. Thus the product is not 6. If, however, we determine the specific heat at very high temperatures, in the neighbourhood of 900° , we obtain the value 0.459, and the atomic heat becomes 5.5.

It has also been discovered that, in every case, towards lower temperatures the rule becomes less accurate, because specific heats tend to zero in the neighbourhood of the absolute zero. Even at ordinary temperatures it has been found that other elements besides carbon do not obey the rule.

Despite the exceptions (silicon, boron), we cannot attribute to chance the very numerous "coincidences" pointed out by Dulong and Petit. It is only necessary to modify the enunciation of the law by saying that the quantity of heat required to raise by 1° the temperature of a solid substance is practically *nil* at the lowest temperatures, increases with rise of temperature, and finally becomes very nearly constant at the value 6.4 calories per gramme atom.

This limit is attained more rapidly for those elements which have a high atomic weight, *e.g.*, for lead it is already reached at 200° C.

In the above we have referred to a solid substance, and not expressly to an element, because the rule remains valid for compounds, *e.g.*, the fluorides, bromides, sulphides of various metals. This is Neumann's Law which asserts that the molecular heat, or the specific heat of a gramme molecule, is constant. This fact can also be expressed by saying that in solid compounds all elements conserve the atomic heat which they had when free. Thus the molecular heat is equal (very nearly) to the sum of the atomic heats.

Iron of atomic weight 56 and sulphur of atomic weight 32 form iron sulphide FeS of molecular weight 88. The gramme molecule will require for every degree rise of temperature an amount of heat equal to the sum of the atomic heats.

With regard to Neumann's Law, we may say that it presents the same kind of exceptions as that of Dulong and Petit. For example, 60 gm. of quartz

SiO_2 formed from one gramme atom (28 gm.) of silicon and 32 gm. of oxygen, absorb at ordinary temperatures only ten calories per degree, but above 400° the same 60 gm. absorb 18 calories per degree, just 6 calories for each of the three gramme atoms composing SiO_2 .

An important development of these ideas will be met with later (Vol. II., Chap. IV.).

Avogadro's Hypothesis

Boyle (1660) and Mariotte (1675) discovered that at a fixed temperature any gaseous mass exerts a pressure inversely proportional to its volume. If the latter is doubled, the pressure is halved, and if the volume is reduced to a third the pressure becomes three times as great.

In 1810 Gay-Lussac found that, keeping the pressure of the gas constant, the volume varies uniformly with the temperature in such a way that for every degree rise in temperature the volume is augmented by $\frac{1}{273}$. This is true

for all gases. A similar discovery was announced by Volta, who determined the value of the coefficient with great accuracy. The same Gay-Lussac (in 1810) published his discovery that the volumes of gases which appear or disappear in a reaction stand in simple ratios to each other. This is best illustrated by an example. When hydrogen and oxygen combine to form hydrogen peroxide or ordinary water, the masses which participate in the reaction are such that, under the same conditions of temperature and pressure, they occupy either equal volumes (H_2O_2), or volumes in the ratio 2 to 1 (H_2O). Furthermore, the water vapour formed has the same volume as the original hydrogen. There was no reason to suppose because of this that the equality of the volumes would correspond to the equality of the numbers of molecules contained in them. That such was the case, however, was affirmed by Avogadro (1811) in the celebrated law, which he preferred to term an hypothesis, and which to-day is familiar to every student of chemistry: *equal volumes of different gases in the same conditions of pressure and temperature, contain equal numbers of molecules.* This is the law of the great Amedeo Avogadro, Count of Quaregna and of Cerreto, and Professor at the Academy of Vercelli.

His proposition, received, to begin with, with reserve, but warmly defended by Ampère, furnished a decisive method for determining the relative masses of the atoms.

Equal volumes of hydrochloric acid HCl , hydrogen H_2 , acetylene C_2H_2 , ammonia NH_3 , methane CH_4 , benzene C_6H_6 , contain respectively the following quantities of hydrogen: 1, 2, 2, 3, 4, 6, and, in particular, 22 litres of each gas at the temperature of melting ice and at normal pressure, contain 1, 2, 2, 3, 4, 6 gm. of hydrogen. Conversely, weights of all the gases, proportional to the respective molecular weights, occupy the same volume. Two kg. of hydrogen, 7 kg. of chlorine, 28 kg. carbon dioxide, 17 kg. of ammonia all represent 22,400 litres.

It has been seen how the laws of isomorphism and specific heats, together with Avogadro's law, make possible the determination of the relative atomic weights. To begin with, hydrogen, the lightest substance, was chosen as the standard of reference, and oxygen was then allotted the atomic weight 16.

When, however, it was found that the ratio O/H was not exactly 16, it was thought preferable to modify the original convention in which hydrogen was chosen as reference, and to take oxygen equal to 16 as basis, the reason being that oxygen occurs more frequently in the determinations of combining proportions. In the modified convention the atomic weight of hydrogen changes from unity to 1.008.

Prout's Law. Isotopes

It was in 1815, only ten years after Dalton put forward his theory, that the English physician Prout introduced his hypothesis on the unity of matter, according to which the atoms of all substances are merely aggregates of atoms of one single type, joined together without loss of weight in extremely solid and, for us, indivisible complexes. Prout had been persuaded of this by observing that the differences between certain atomic weights were multiples of the weight of the atom of hydrogen, and he drew the conclusion that hydrogen was the unique primordial constituent of all matter.

This hypothesis met with favour to begin with, but later it was set aside when more precise measurements of the atomic weights—which at the time of Prout were not known with sufficient accuracy to justify his pronouncement—gave results no longer in harmony with the supposed law.

For example, the atomic weight of magnesium was 24·3, that of chlorine 35·46. Nevertheless that Prout's assertion had some justification is immediately obvious on inspecting the list of the first 25 atomic weights, putting oxygen equal to 16.

Hydrogen. 1·008	Helium. 4·00	Lithium. 6·94	Beryllium. 9·02	Boron. 10·82	Carbon. 12·00	Nitrogen. 14·01
Oxygen. 16·00	Fluorine. 19·00	Neon. 20·2	Sodium. 23·00	Magnesium. 24·32	Aluminium. 26·96	Silicon. 28·06
Phosphorus. 31·02	Sulphur. 32·09	Chlorine. 35·46	Argon. 39·88	Potassium. 39·10	Calcium. 40·07	Scandium. 45·10
	Titanium. 48·10	Vanadium. 51·00	Chromium. 52·01	Manganese. 54·93		

Investigations were made to find out to what extent the errors of experiment could be of influence in displacing the atomic weights of the elements from the neighbouring integral numbers, thereby masking the law of multiples. We pass over these researches which have been superseded by later work. At the present time the atomic weights are known exactly to the second decimal place,

and those referred to above may safely be taken as correct. It is obvious that these approximate to the whole numbers 1, 4, 6, 9, 12, 14, 16, 19, 20, 23, 27, 28, 31, etc.

If the experimental values were distributed at random, we should expect that out of 25 only 5 would have decimal parts lying between zero and 0.10 or between 0.90 and 0.999, because out of 10 points picked out *at random* on a centimetre rule, only one-fifth of these fall in the intervals of 2 mm. taken half to the right and half to the left of the marks of the rule.

Actually, however, only very few of the atomic weights given above fall outside the interval $+ 0.10$ to $- 0.10$.

To explain the enigma of this remarkable state of affairs, it was suggested that Prout's rule was a limiting law, attributable to a cause whose effects did not appear in all their simplicity because of secondary influences which produced perturbations.

Everything, however, was explained when the study of radioactive transformations led Soddy and Fajans to propose that two atoms might possess different atomic weights, and in spite of this, have chemical properties which were so similar that the ordinary methods of separation based on chemical affinity would be powerless to separate them. The physical properties are likewise almost identical for these "brother elements," termed isotopes. Aston, using an ingenious apparatus which we shall later describe, resolved neon into two isotopes of atomic weights 20 and 22, and established that chlorine was a mixture of two isotopes having integral atomic weights 35 and 37. The simultaneous presence of the two simple substances 35 and 37, is the cause of the non-integral atomic weight (35.46) of chlorine. As a result of this work Prout's hypothesis becomes a law and assumes an importance of the first magnitude in our theories of the structure of atoms.

In the history of Prout's hypothesis we have another of the many cases in which the inductive method has led to the discovery of a simple fundamental law from a few apparently very complicated facts. Thus, from Kepler's planetary laws, Newton proceeded to derive the law of universal gravitation which regulates the whole world. Dalton and Boltzmann, from one or two experimental laws, created the atomic theory, and in like manner

Planck and Einstein by a process of generalisation have built up the new physics of quanta.

To return to Prout's idea and to the notion of the uniformity of matter, it remained still to be explained why the atomic weights are integral if oxygen is taken as 16, whereas they are not if hydrogen = 1 is used as basis. The reason is that the ratio of the atomic weight of hydrogen to that of oxygen is not 1 : 16, but 1.008 : 16. How then can hydrogen be the unique constituent, the indivisible unit of creation, if the substances it produces by agglomeration are not its exact multiples by weight ?

Actually, none of the atomic weights are integral multiples of hydrogen ; in every case there is a deficiency of 8 thousandths. The relativity theory of Einstein has removed this difficulty.

Even before the discovery of radioactivity, which was to lead to the discovery of isotopes and make known to us the relationships existing between the different atoms, an important development had induced chemists to adopt the same general idea of a common parentage of the elements. This was the discovery of Mendeleieff (1869) that between the properties of the elements and their atomic weights, there exist *periodic* relationships, *i.e.*, arranging the elements in order of their atomic weights beginning with the smallest, the properties of the elements recur at definite intervals.

Mendeleieff's Classification

If the elements are arranged in order of increasing atomic weights, it is observed that there exists a rhythmic variation, at equal intervals, in their physical and chemical properties such as melting-point, volume occupied by a gramme molecule, electro-chemical character, tendency to form various chemical compounds, appearance, etc. Putting aside hydrogen, which is the cornerstone of the edifice and hence enjoys a place apart, and passing to the elements which come after, lithium, beryllium, etc., after traversing the series up to neon, we arrive at sodium, which is closely similar to lithium. With sodium a new series of eight substances is initiated analogous to the preceding eight, each element having its appropriate twin in the preceding series.

These two consecutive series are each formed of 8 elements ; in

each the valency beginning with 1 (lithium and sodium) increases steadily up to 7, to fall abruptly to zero for the final members of both series, neon and argon respectively, two gases which belong to the group of so-called rare gases, which are devoid of any tendency to combine chemically. After these two periods, which terminate in elements altogether different from the initial elements, comes a series whose components are found to be similar, taken in order, to those already found, and so on.

All these facts are combined and exhibited in Mendeleieff's system which is reproduced in the table given on p. 12.

This differs from the original of the Russian scientist in some particulars. The chief change has been the introduction of several elements discovered since Mendeleieff gave the table. A little retouching has also been necessary, such as the interchange of argon and potassium, tellurium and iodine, about which we shall have something to say later.

After the first two periods the variation of properties with atomic weight becomes more complicated, and the following two periods each contain 18 elements. The interval of the periodicity then becomes 32, which follows from the correspondence between barium (56th element) and radium (88th element). Thus the periods have the values :

2, 8, 18, 32,

and it is easy to verify the curious fact that these numbers equal in order, twice the squares of 1, 2, 3, 4.

It was only in 1925 that Pauli gave the reason for this *arithmetical scheme* in the periodic system. He was able, in the light of the quantum theory, to find the key to the Mendeleieff system and to discover the principle underlying the successive building up of the various atoms beginning with the simplest. This work will be discussed in Vol. II., Chap. III.

For the present it will merely be noted that the *accuracy* and *certainty* of the succession of the elements in the classification discovered by Lothar Meyer and Mendeleieff (1869) was not attained until 1913 following upon Moseley's discovery, as we shall show in Chap. VI.

Periodic Classification of the Elements

	I	II	III	IV	V	VI	VII	VIIIa	VIIIb	VIIIc	A
1	1 H 1.008										2 He 4.00
2	3 Li 6.94	4 Be 9.02	5 B 10.82	6 C 12.00	7 N 14.01	8 O 16.00	9 F 19.0				10 Ne 20.2
3	11 Na 23.00	12 Mg 24.32	13 Al 26.96	14 Si 28.06	15 P 31.02	16 S 32.06	17 Cl 35.46				18 Ar 39.98
4	19 K 39.10	20 Ca 40.07	21 Sc 45.1	22 Ti 48.1	23 V 51.0	24 Cr 52.01	25 Mn 54.93	26 Fe 55.84	27 Co 58.97	28 Ni 58.68	
5	37 Rb 85.44	38 Sr 87.63	39 Y 88.9	40 Zr 91.25	41 Nb 93.1	42 Mo 96.0	43 Tc 98.0	44 Ru 101.7	45 Rh 102.9	46 Pd 106.7	80 Kr 82.92
	47 Ag 107.88	48 Cd 112.40	49 In 114.8	50 Sn 118.7	51 Sb 121.77	52 Te 127.5	53 I 126.92				54 Xe 130.2
6	55 Cs 132.81	56 Ba 137.37	RARE EARTHS	72 Hf 178.6	73 Ta 181.5	74 W 184.0	75 Re 188.7	76 Os 190.9	77 Ir 193.1	78 Pt 195.2	
	79 Au 197.2	80 Hg 200.6	81 Tl 204.4	82 Pb 207.20	83 Bi 209.0	84 Po (210.0)	85—				86 Rn (222.0)
7	87	88 Ra 226.0	89 Ac (226)	90 Th 232.15	91 Pa (230)	92 U 238.2					

RARE EARTHS							
57 La 138.9	58 Ce 140.25	59 Pr 140.9	60 Nd 144.3	61 Pm	62 Sm 150.4	63 Eu 152.0	64 Gd 157.3
65 Tb 159.2	66 Dy 162.5	67 Ho 163.5	68 Er 167.7	69 Tm 168.5	70 Yb 173.5	71 Lu 175.0	

visible world by mathematical formulæ, which enable us to pass from phenomena on a large scale to molecular events. In this way the atomic hypothesis could be subjected to test.

At the end of the century, however, a whole series of discoveries were made, which threw a great deal of light on the problem, and made possible delicate experiments on the phenomena exhibited by single atoms and molecules. The atoms were subjected to physical test, and with the application of purely physical and sometimes physical chemical methods an inexhaustible field of scientific research lay open. A great number of physicists took up the work, and the centuries-old desire to understand the subtle mechanism of nature by a study of the behaviour of its ultimate constituent particles was at last realised.

While great advances in this field were being made, there came to light, one after another, various phenomena for which the wave theory of light was quite incapable of providing an explanation.

By the year 1905, it was felt necessary to parallel the granular structure of matter with a possible granular structure of light, and, under the impulse given by the new idea, many phenomena of interaction between light and matter were carefully studied. Chemistry also was deeply concerned in the new developments, for the knowledge of the single atom and its behaviour in the presence of electromagnetic energy (light) might lead to the explanation of many little understood effects, such as, for example, the phenomena of valency, which remained very obscure.

It is not intended at this stage to summarise these new developments which have later to be discussed in detail. We merely mention that the discoveries referred to above which opened up such fruitful lines of research, were especially, *X-rays, radioactivity, isolation of the electron, ionisation phenomena, Brownian motion, photoelectric effect, isotopy, experiments of Franck and Hertz, etc.*

The above list makes it abundantly clear why *modern physics* has become essentially a study of the atom. Other branches, for example *terrestrial physics, stellar physics, magnetism, sound*, have also profited by the new work. The study of sound, for example,

has been greatly assisted by the application of the triode valve, that marvellous piece of apparatus based on the electron emission of an incandescent filament, which has made wireless telephony and television practicable.

In the rapid progress which has been made, profitable links between the different branches of physics have been established. A discovery in one field has explained obscurities in another. For example, X-rays have made possible the exploration of the interior of crystals, and the investigation of what may be called the crystal skeleton. Spectroscopy, including stellar spectroscopy, has thrown a great deal of light on the structure of the atoms. The α -, β - and γ -rays emitted by radioactive substances and the magnetic properties of the atoms have both been called upon to contribute, in various delicate experiments, to the discovery of the plan of construction of the 92 different elements which make up the Universe.

Before entering upon the main argument it will be desirable to begin with a brief chapter on optics and the electromagnetic theory of light. By doing so, we keep to the historical order of events, and in addition we are able to see clearly how modern physics and, in particular, the atomistic doctrine, springs from the union of two great scientific currents, the study of the ultimate particles of matter, on the one hand, and the investigation of the ultimate particle of electricity on the other.

CHAPTER II

LIGHT

Fresnel's Wave Theory

ANALOGY, which plays so important a part in scientific discovery, had suggested two hypotheses for the interpretation of luminous phenomena, *the emission hypothesis* in which light was imagined to be a bombardment of particles similar to those which affect the olfactory organ, and *the wave hypothesis*, an idea suggested by the oscillations observed when still water is disturbed at a point. The emission hypothesis had been put forward by Empedocles, and was backed by the authority of Kepler, Newton and Laplace. The wave standpoint, which goes back to Aristotle, was adopted by Descartes, Huygens and Euler.

It was Fresnel (1788-1827) who, following the method of the nineteenth century, established the wave theory of light on a firm basis in a series of experiments, the precision of which is the more remarkable remembering the experimental facilities at his disposal. He discovered and studied a great number of interference, diffraction and polarisation phenomena. The French Academy offered at that time a prize for a study of diffraction and Fresnel submitted his memoir to a committee of five members: Arago, Biot, Gay-Lussac, Laplace and Poisson. It would be difficult to think of a more select group of physicists.

Since light exhibits periodicity, there must be something which vibrates. This something is "the ether," but after centuries of controversy we must resign ourselves to the fact that there is no definition of the ether which is related (even remotely) with ordinary mechanics. In the words of the Marquis of Salisbury at the 1894 meeting of the British Association, "the main if not the only function of the word *ether* has been to furnish a nominative case to the verb to undulate."

As to the nature of these waves, it must be realised that down to the present time physics has always tried to give a mechanical representation of phenomena, that is, to reduce them to motion. It is therefore not surprising that Huygens (1629-95) had a purely mechanical conception of light waves. It could not be supposed, however, that it was matter which vibrated as in the case of sound, for light is transmitted equally well in a vacuum. To get round this difficulty, physicists admitted the existence of a special fluid—the ether—endowed with unknown properties and capable of rendering that service which man's desire for material representations required of it.

Light waves are transverse, that is to say, the oscillations of the vibration vector occur in the plane normal to the direction of propagation of the light, and are sinusoidal, following the law of the sine.

The transverseness of luminous vibrations follows from the fact that the ordinary and extraordinary rays produced in the double refraction of light by a crystal are incapable of interfering, either totally or partially, when superposed.

Between the wave-length λ and the frequency ν the well-known relation

$$\lambda = \frac{c}{\nu} = c\tau$$

holds, where c is the velocity of light, τ the period.

Light added to light can produce darkness. This is the phenomenon of interference to which attention was drawn by Padre Grimaldi in 1665. To obtain the effect it is necessary to superpose at a point two rays from the

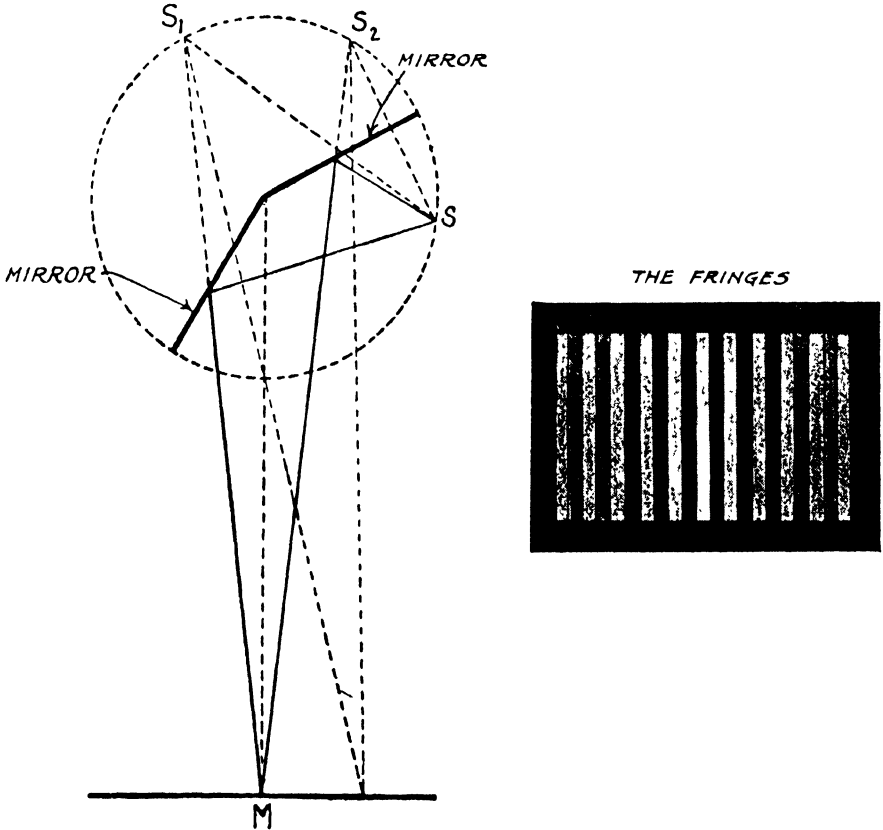

FIG. 2.

same source, which have traversed paths, different in length by half a wave-length (or an odd multiple of half wave-lengths).

Two monochromatic light rays which do not have a common origin cannot remain out of phase for an appreciable interval of time. If at one moment they are in opposite phase, as required for the production of interference, shortly afterwards they come into phase and light returns to where previously there was darkness.

Fresnel carried out the famous experiment which is appropriately known as Fresnel's mirrors. The rays issuing from a narrow slit illuminated with

monochromatic light, fall onto two mirrors of black glass, inclined to each other at an angle of nearly 180 degrees, and so arranged that their line of intersection is parallel to the illuminated slit. Corresponding to the slit S, two virtual images S_1 and S_2 are formed, from which all the reflected rays appear to proceed. These act as two neighbouring sources in perpetual agreement of phase. At a point M of the screen there will be continuous light if the difference of length between S_1M and S_2M is equal to a whole wave-length, and absolute darkness if this difference equals half a wave-length.*

Thus fringes, alternately bright and dark, appear. If the light used is white, the fringes will be coloured because the effect is complex, the actual pattern resulting from the superposition of systems of monochromatic fringes.

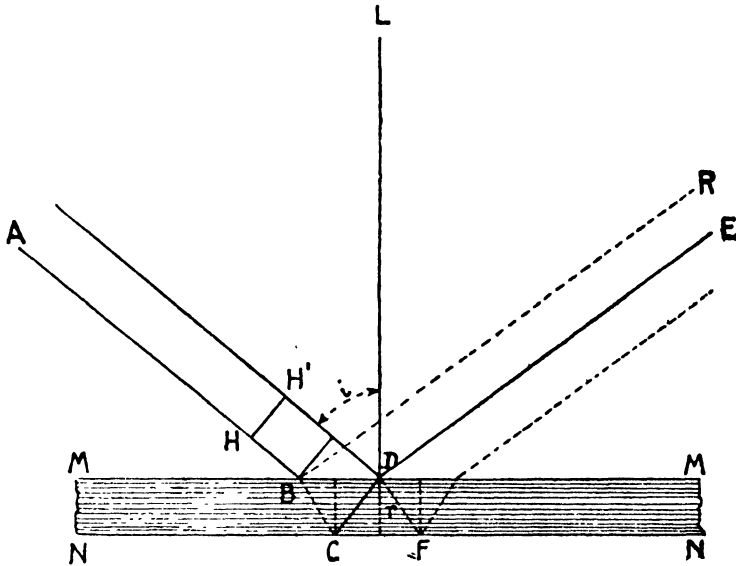

FIG. 3.

A thin layer of any transparent substance exhibits bright colours when illuminated with white light. As examples of thin layers giving the effect, we may mention the films of oxide which form on bright steel when it is heated, and the film formed by oil or petrol spreading on water. Above all, however, it is the soap bubble with its constantly changing thickness which gives the richest and most marvellously varied colours.

Newton allotted a whole chapter of his celebrated^{*} treatise on optics to the subject of thin films, and Thomas Young (1773-1829) interpreted the

* The region in front of the mirrors is an interference field in which a point whose distances from the two virtual sources differ by half a wave-length will receive no light.

Now, the locus of points, such that the difference of their distances from two fixed points of the plane is a constant, is a hyperbola, and therefore the whole field is divided into hyperboloid surfaces, alternately bright and dark.

phenomena famed under the name "Newton's rings," in terms of the wave theory.

When monochromatic light is allowed to fall on a thin transparent plate (Fig. 3) one part of the light is reflected from the top surface of the plate, and another part penetrates the plate and is reflected from the underneath surface. The additional path which this light has had to traverse causes a certain retardation of phase with respect to the light returned from the top surface, and if the thickness of the plate is such as to cause a retardation of a wave-length the two reflected beams are in agreement of phase, their superposition yields an intensity maximum and the plate appears bright. If the thickness is such as to cause the two reflected beams to be in opposite phase the plate appears dark. It should be noted that in the reflections at B and D there is a phase loss of half a period.

The colours of thin plates seen by transmitted light are explained in the same way.

The various phenomena of interference allow of the determination of the wave-length of light. The precision of the measurement has become such that the unit adopted is a ten thousandth part of a thousandth of a millimetre. The unit is called the Ångström, after the celebrated Danish physicist, who first made a series of very precise measurements of wave-length. A mono-chromatic radiation, such as a spectral line expressed in Ångström units, is, for example, 6438·4696 Ångström, one of the cadmium lines.

In the X-ray region a still smaller unit is employed which equals 10^{-11} cm., and we work to the hundredth part of this unit.

For a long time the adversaries of the wave theory were able to raise the objection that if light, like sound, consists in a vibratory motion, it ought to bend round obstacles as does the sound of a bell which reaches us from behind a house. This brings us to the phenomenon of diffraction which shows that light does actually envelop or go round obstacles. Anyone can perform the following experiment: a very narrow slit (0·5 mm. wide) is strongly illuminated, and the light issuing from it is passed through a second slit, parallel to the first and of variable aperture, to fall finally onto a screen. If light is propagated exactly in straight lines we should observe on the screen a band of light perfectly definite in outline, the width of which decreases as the diameter of the second slit is diminished. These conditions are not realised. When the second slit has been sufficiently reduced, the patch of light on the screen, instead of contracting further, gets larger and exhibits at the sides parallel bands alternately bright and dark, which are termed diffraction fringes. Fresnel in 1819, in a memoir to the Academy of Sciences, gave the explanation and showed that the wave theory explained all the facts which Newton and he himself had observed in this field.

Consider a light wave emitted from a luminous point O (Fig. 4). All points reached simultaneously in the progress of the wave must be regarded as new luminous centres from which myriads of secondary waves start out in all directions. The effects of these when combined in accordance with the laws of interference, are such that at any point reached by the light everything occurs just as if the light had come in a straight line from O. When, however, an opaque screen BB is placed in the path of the wave, only that part of the wave which is left free to proceed can emit the secondary wavelets, and in the plane *aa* the effects of these combine so as to produce maxima and minima in the illumination at the central region A. This simple example makes it clear that light waves can bend round obstacles, as do sound waves. Being incomparably shorter than the latter, however, they give effects only on a very small scale. For light waves a screen of a few millimetres represents

an obstacle comparable to a mountain for sound waves. As the latter are stopped by the mountain, so light waves are unable to bend very much round the screen.

Contemplating the marvellous development of the theory formulated by Fresnel, Arago wrote in 1830: "Despite the many reservations which must be made when hazarding a pronouncement about our successors, I venture to affirm that as regards the subject of diffraction, they will not add anything essential to the discoveries with which Fresnel has enriched science."

One hundred years have since passed, but this prophecy still remains valid.

What are the relations between these vibrations of the ether and the luminous ray? Do they take place along the ray or are they transverse vibrations, *i.e.*, contained in the plane normal to the ray? None of the phenomena of interference or diffraction yield information on this point. If the vibrations were longitudinal a luminous ray would be perfectly

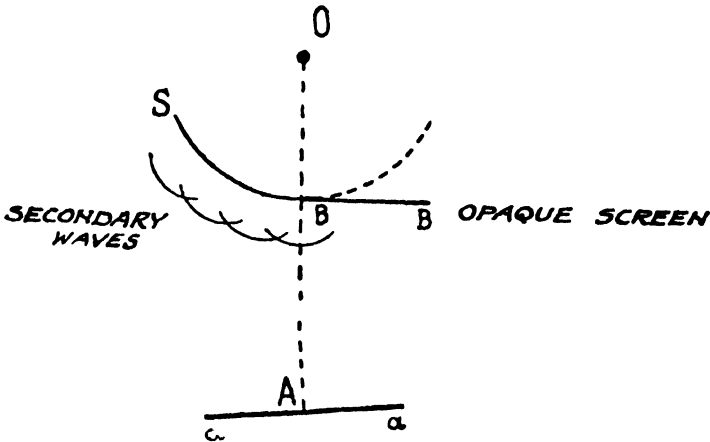

FIG. 4.—Diffraction produced by secondary waves.

symmetrical, and ought to behave in the same way in all the planes containing it. If, on the other hand, certain phenomena indicate the existence of a disymmetry the hypothesis of longitudinal vibration breaks down immediately. Such disymmetry is observable in *polarisation* phenomena. Natural light is unpolarised, but there are many ways of polarising light, *i.e.*, of bringing about a plane of preference for the transverse vibrations. One way is to use what is called a *nicol*.

Certain substances have the property of rotating the plane of vibration of a ray of polarised light passing through them. One such substance is quartz. If a plate of quartz, the faces of which have been cut perpendicular to the optic axis, is introduced between two crossed nicols, which have, as we know, the property of completely extinguishing light, the light is restored. The plane of vibration has been rotated, and the second nicol is no longer capable of extinguishing the rays.

These crystalline substances owe their optical activity to the absence of symmetry about the axis of the crystal, which frequently—as with quartz—is revealed by the presence of certain facets, termed hemihedra. There are also substances which owe their property of rotating the plane of polarisation to the disymmetry of their molecules (for example, the sugars).

More about Diffraction. Gratings *

The phenomenon of diffraction is easily explained when we consider the passage of waves through a narrow slit. Suppose a wave emitted by a distant point source (see Fig. 5) propagated through a narrow slit AB in an opaque diaphragm. Considering the various points ACB of the slit as independent centres of vibration, it is clear that the wave does not merely proceed along its original path in the direction AH, but diverges to right and left. In the direction AH there will be seen a luminous image of the slit. In a direction inclined to AH, such that CE equals half a wave-length, E is in opposite phase to A, and hence along the wave front AD there will be pairs of elements always in opposite phase. The effect will be that in this particular direction a "dark image" of the slit is formed. For a direction at a greater angle a luminous image will once more be obtained, but of lower intensity than the central undiffracted image. For a still greater inclination there again occurs interference of the points of the wave point taken in pairs, and a dark fringe is obtained, and so on.

To sum up, a system of fringes is obtained symmetrical with respect to the central line which is bright. The first dark fringe occurs at an angle β ,

$$\text{where } \sin \beta = \frac{\lambda}{a}$$

By tracing a number of extremely fine, equidistant lines on a glass plate by the aid of a diamond mounted in a dividing engine, a *Fraunhofer grating* is obtained. The number of lines in such a grating amounts to several hundreds per millimetre (see Fig. 6).

With these gratings diffraction spectra are obtained. A monochromatic light travelling along the direction LX encounters the series of slits BC, DE, etc. Two corresponding points, such as A and C, lie a distance apart equal to m , which is the period of the grating or grating constant. In a direction making an angle β with the incident beam, the rays from the grating

will produce light if $m \sin \beta = \lambda$, for in that case the points C^1, E^1, G^1 on the wave front will be vibrating in phase. With white light there is a separation of the various colours, because the angle β is different for each colour.

Diffraction spectra are also obtained by means of *reflection gratings* (see Fig. 7), which are constructed from metallic mirrors, the highly polished surfaces of which are furrowed with a very large number of parallel equidistant tracts traced by means of a dividing engine. The reflection gratings of Rowland (1848-1901) with 10 to 15 million lines in a centimetre are famous.

SA, SC is the direction of the incident beam; the reflecting tracts AB, CD have the part of the transparent slits in the Fraunhofer grating, and the

* A reader wishing to refresh his knowledge of physical optics might read "Optica Fisica," of Prof. Vasco Ronchi, 1928, or R. W. Wood's "Physical Optics."

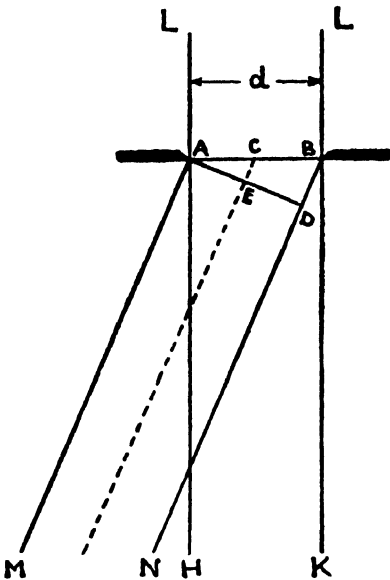

FIG. 5.

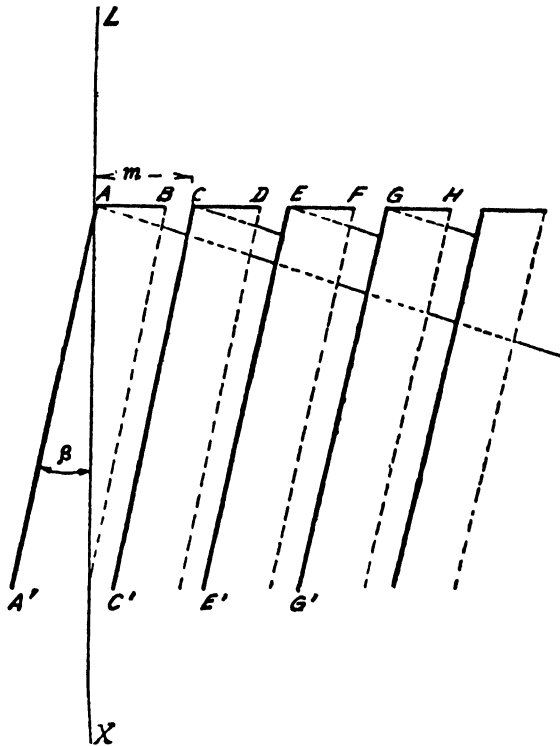

FIG. 6.

points, such as A and C, become centres of diffraction. There are certain particular directions of the diffracted light for which the corresponding points on the diffracted wave front are in agreement of phase.

It is seen from the figure that that occurs when the sum of the two paths AJ and - KC equals a multiple of the wave-length λ , or, expressed symbolically, when

$$m (\sin \phi - \sin \psi) = K\lambda,$$

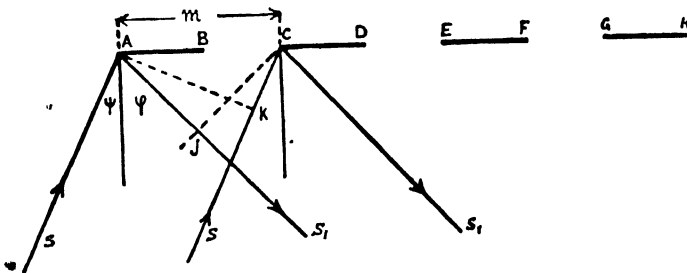

FIG. 7.—Reflection grating.

where K is a whole number. For integral values of the number K luminous fringes are formed, separated by dark regions. If the light instead of being monochromatic, is natural light, a spectrum is obtained, or rather a series of spectra, one corresponding to $K = 1$ (the first order spectrum), another to $K = 2$, and so on.

Diffraction spectra provide a convenient means of measuring the wave-length of different coloured lights. Measurement of an angle and application of the formula

$$\lambda = m \sin \beta$$

give the wave-length λ , the grating constant m being assumed known.

It is evident that the resolving power of a diffraction grating, that is, its ability to separate lines of different wave-length, will increase as the period m is diminished, or, in other words, as the number of lines in a cm. is increased.

MODE OF OPERATION

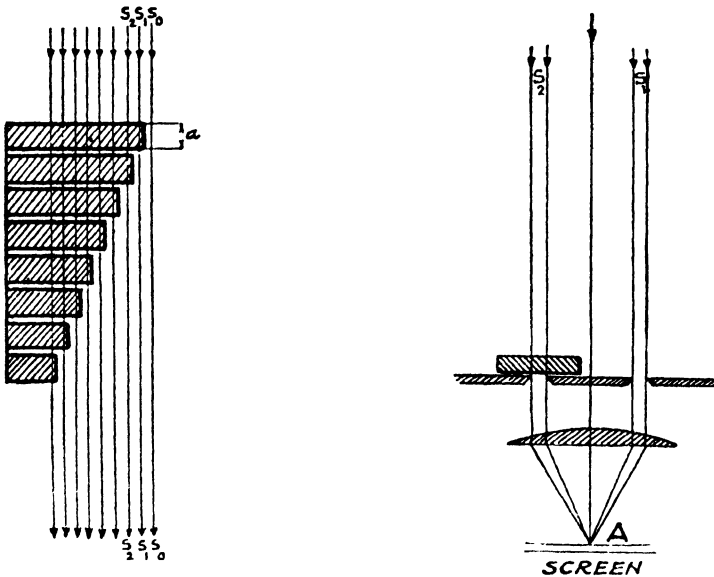

FIG. 8.—Michelson's echelon grating.

Two rays of different wave-length λ_1, λ_2 respectively, will be deviated through angles β_1 and β_2 , such that $\sin \beta_1 = \frac{K \lambda_1}{m}$, $\sin \beta_2 = \frac{K \lambda_2}{m}$, and the difference

between these angles (or, rather, their sines) is $\frac{K}{m} (\lambda_1 - \lambda_2)$. Thus it is

desirable to have a very fine grating and to work with spectra of high order. As with ordinary gratings the second of these expedients is not possible, owing to the fading away of the image, and the former can only be realised within the limits fixed by mechanical difficulties of construction, recourse is had to an artifice.

The order of a spectrum increases with increase in the path difference of rays proceeding from adjacent elements of the grating. Thus by lengthening this path difference the order of the spectrum, and hence the resolving power,

can be increased. This is the principle of the modern echelon gratings due to Michelson.

One piece of apparatus of this kind consists of a number of glass plates, each several centimetres thick, piled one on another to form a staircase structure (see Fig. 8). If n is the refractive index of the glass with respect to air, *i.e.* the ratio of the velocity of light in air to the velocity in glass, then clearly the greater of the light paths of two corresponding rays is $a \times n$. The illumination of the screen will be a maximum when

$$K\lambda = an - a \qquad K = \text{an integer.}$$

It follows from this relation that $\lambda = \frac{a(n-1)}{K}$, and for $a = 1$ cm. (thickness of the plates), $n = 1.5$ (refractive index) and $\lambda = 50 \times 10^{-6}$ cm., the spectrum which appears in the normal direction is of the order $K = 10,000$, and has all the properties appropriate to a spectrum of such high order. With these

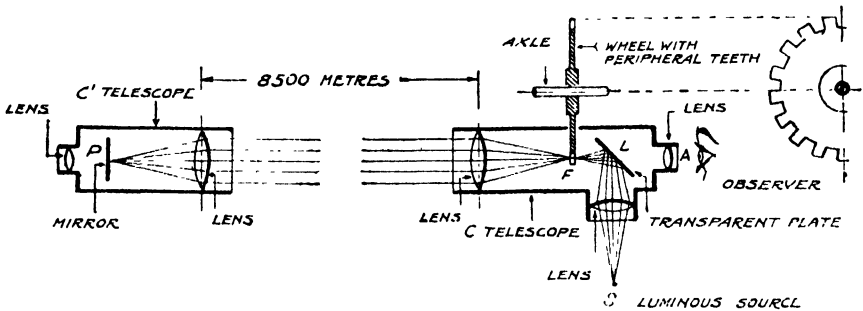

FIG. 9.

modern interferometers it is possible to resolve lines which differ in wave-length by no more than one *ten millionth of a micron*.

$$\left(1 \text{ micron} = 1 \frac{\text{millimetre}}{1,000} \right).$$

They also provide extraordinarily delicate instruments for measuring, as well as resolving, the wave-lengths of monochromatic radiations.

The Velocity of Light and its Direct Measurement

Galileo was the first to attempt an experimental study of the propagation of light. Two observers, A and B, were placed at a certain distance apart and given lanterns, the light from which could be cut off by a shutter. The observer A suddenly opened the shutter of his lantern, and as soon as observer B saw the signal, he in turn uncovered his lantern. The interval of time between the opening of A's shutter and A's observation of B's signal should be that required for the light to traverse and retrace the path AB. Galileo's experiments with a distance $AB = 200$ metres, and experiments by the Accademia del Cimento with $AB = 2$ kilometres, gave no result. We know now why this was so, but the principle of the method was quite sound, and it was later adopted by Fizeau.

The first measurement of the velocity of light in interplanetary space was made by Roemer, a Danish astronomer, in the year 1675. We shall confine ourselves to giving descriptions of Fizeau's and Foucault's methods for determining the time occupied by light in traversing a given terrestrial distance.

Fizeau set up at a distance of 8,500 metres two telescopes CC' on a common axis, and with their objectives facing each other (see Fig. 9). In one of the telescopes a plane parallel transparent plate was mounted at 45 degrees to the axis in front of the eyepiece. A side tube carrying a lens projected the image of the light source S to the focus of the objective, so that finally a parallel beam of light was received by the other telescope. The objective of the latter brought the rays to a focus at which a mirror P was placed. After reflection the rays returned to the focus F , from which they had issued originally, and were observed as a luminous point by means of the eyepiece A .

In the focal plane F' a toothed wheel was rotated, and as the velocity of rotation increased, the luminous point was seen to vanish, but after a further definite increase in speed it reappeared. The explanation of these effects is as follows: when the time required for a light ray (emerging through the gap between two teeth of the wheel) to return to F' after having travelled the double distance, 17 km. in all, is exactly equal to the period between two transits of a gap in the toothed wheel, it is obvious that the light point will

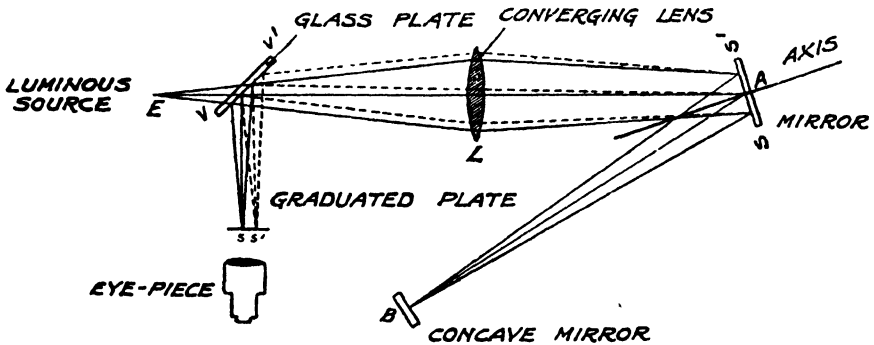

FIG. 10.—Foucault's method.

be visible. If, on the other hand, the time for the double journey is just sufficient for a tooth to supplant a gap, then the light ray will be cut off. Finally, by accelerating the wheel, vision of the source is restored. The number of revolutions per second, the diameter of the wheel at the indentations, the distance P to F were all known. The distance F to P , P to F was covered in $\frac{1}{175,000}$ th of a second, and the following value was deduced for the velocity of light: $17 \times 18,000 = 300,000$ km./sec. approximately.

In 1862 Foucault (1819–68) worked out another method (see Fig. 10), in which the light emitted by a luminous point E was made to pass through a glass plate VV' and a converging lens L , to be reflected at a plane mirror SS' . The real image of the point E fell on a concave mirror B with its centre of curvature at A . In this way the return beam reflected at SS' traversed the reverse path, undergoing a further partial reflection in VV' to form an image on the graduated plate ss' , which was observed with an eyepiece O . The whole apparatus occupied a space of not more than a few metres in linear extension.

By rotating the mirror SS' at a high velocity it is clear that the reflected image formed on the scale will be displaced because the beam travelling to and from B finds on its return the mirror SS' in a different position. As a consequence the image is seen to be displaced, and the amount of displacement can be measured. The distances involved and the velocity of the mirror are

known, so that it is easy to deduce the angle of rotation corresponding to the time occupied by the light in traversing twice the path AB with velocity c . This angle determines the *angular deviation* of the return beam, which in turn fixes the displacement on the scale. Thus the latter is related to known magnitudes and to the single unknown in the problem—the velocity. From these experiments Foucault deduced for the velocity of light the value 298,000 km./sec.

In material media the velocity of light is always smaller than *in vacuo*, and has the value $\frac{300,000}{n}$ km./sec., where n is the refractive index of the medium. In water, for example, n is about $\frac{4}{3}$. The refractive index of a medium varies, as a rule, with the wave-length, and the velocity of light for the various monochromatic radiations has different values in the same medium. In gases the index n is approximately unity for all radiations, so that in a gas the velocity is very nearly 300,000 km./sec. whatever the wave-length.

Observations on variable stars show that the velocity of propagation in vacuum must be identical for the different wave-lengths. If that were not the case, at the moment of extinction, the wave-length having the smallest velocity should be perceived last, and at reappearance the higher velocity radiation should reach us first. The colour of the light perceived would then exhibit variations which, in fact, have never been observed.

A Recent Determination of the Velocity of Light. A. A. Michelson

The measurements of the velocity of light which have been discussed up to now were made many years ago. Nevertheless, Fizeau's method represented a great step forward, and it may be said that, in principle, the more elaborate and perfect measurements follow the same lines.

It is not surprising in view of the importance of knowing the exact value of this natural constant, that many physicists should have repeated the measurement, and so we have the experiments of Newcomb, Fabry, Pérot, etc.

In the autumn of 1926 A. A. Michelson, in the U.S.A., concluded his investigations of the problem which had extended over a number of years, and his account of the work appears in the *Astrophysical Journal* for January, 1927.

A beam of light was made to traverse twice the distance between Mt. Wilson and Mt. St. Antonio, in all 71 km. The time required for light to cover this distance is 0.00023 of a second.

The experimental arrangement was the following (see Fig. 11): the light passes through the slit S onto a rotating octagonal mirror, shown in Fig. 12, is reflected at B, then at C, and finally strikes the concave mirror D (at the Mt. Wilson station). The beam is rendered parallel and travels to the Mt. St. Antonio station, where the concave mirror and the plane mirror f reverse its direction. On its return to Mt. Wilson the beam is "observed" by the aid of the mirror and the prism, as shown in Fig. 11.

The rotating mirror was constructed either of glass or of polished nickel steel. It was set into rapid rotation by means of a blast of air. Thus, when the octagonal mirror was rotating at the rate of, say, 356 revolutions per second, the light was able to cover its entire path and return to find the mirror displaced by one-eighth of a revolution. By a special arrangement, which we shall not describe, the velocity of rotation of the mirror could be determined. The distance between the fixed points at the two stations had been accurately measured and tested by the "U.S. Coast and Geodetic Survey."

The following are the final results of these very accurate measurements of the velocity of light :—

299,813 km./sec.	299,796 km./sec.
299,795 " "	299,803 " "
299,796 " "	299,780 " "

Taking account of the "weight" of the different results, that is to say, their respective reliabilities, and including several values of lower weight

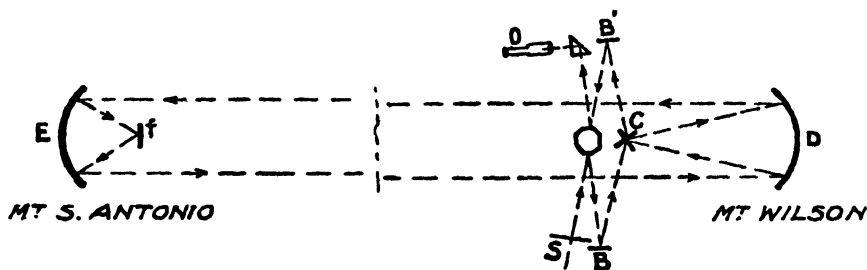

THE ROTATING
OCTAGONAL MIRROR

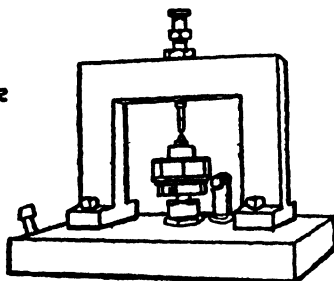

FIGS. 11 and 12.

obtained in the previous year, the mean value finally submitted is $299,799 \pm 4$ km./sec.

The approximate value, 3×10^{10} cm./sec., is adopted for most purposes.

Limits of Accuracy in the Measurement of Wave Length. Technical Applications of Interference

The use of diffraction gratings to measure wave-length has already been described on p. 30. In this method the wave-length λ is compared with the grating constant m (the period).

Many other methods based on interference phenomena have been devised for the measurement of λ . The precision of these measurements is limited by the circumstance that in nature strictly monochromatic radiations representable by simple sine waves are not found. Every radiation, even a single spectral line, is composed of an assembly of sinusoidal monochromatic waves of different wave-length. For a spectral line the wave-length λ varies in general within narrow limits $\lambda, (\lambda + \Delta\lambda)$. The interval $\Delta\lambda$ is termed the *width* of the spectral line, the apparent width of spectral lines being, in fact, proportional to $\Delta\lambda$.

The limitation referred to above consists in the impossibility of measuring a wave-length with an error less than $\Delta\lambda$ whenever the spectral line, although nominally "monochromatic," has a finite width $\Delta\lambda$. In interference apparatus of the type of Michelson's *echelon grating* (see p. 30) this limitation is observed as a disappearance of interference fringes when the difference of optical path between the two interfering beams just exceeds the value :

$$l = \frac{1}{2} \frac{\lambda^2}{\Delta\lambda} = \frac{\lambda}{2} \frac{\lambda}{\Delta\lambda} *$$

The width of the sodium D lines ($\lambda = 5890 \text{ \AA}$) at 100° C. is about 0.01 \AA . Thus, with either of these lines interference can be obtained with a path difference which is not greater than $\frac{1}{2} \cdot \frac{5890}{0.01} \approx 250,000 \times$ (one wave-length).

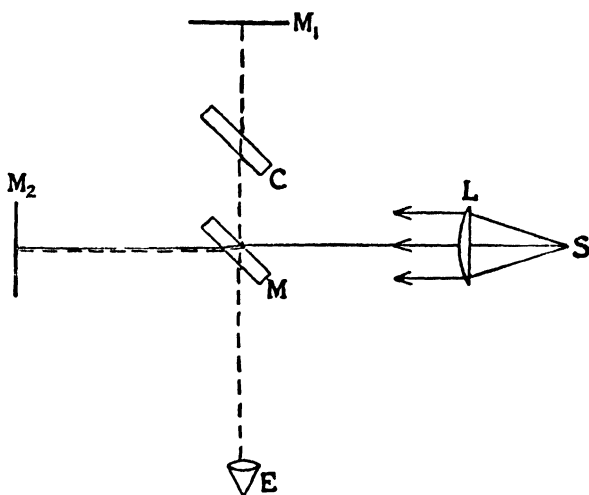

FIG. 13.

The mercury vapour lamp gives a complex line $\lambda = 2536.52 \text{ \AA}$, whose components have width, $\Delta\lambda = 2 \times 10^{-4} \text{ \AA}$.

There are many pieces of apparatus, termed interferometers, which enable interference fringes to be obtained with optical path differences of the order of a million times the wave-length. Among these may be mentioned the interferometers of Michelson, Jamin, and Fabry and Péro, the Lummer plate, and the echelon grating.

Michelson's interferometer is shown schematically in Fig. 13. Light from a slit S illuminated with monochromatic radiation is incident on a half-silvered

* If, for example, l contains a whole number of wave-lengths λ , it will contain an odd number of half wave-lengths of the radiation, $\lambda + \Delta\lambda$ when

$$\frac{l}{\lambda} - \frac{l}{\lambda + \Delta\lambda} = \frac{1}{2}$$

Thus, whenever one radiation interferes giving a minimum, the other gives a maximum.

mirror M, where it is partly refracted. The final paths of the two beams are clear from the figure. The mirrors M_1 and M_2 reverse the rays incident on them, and these rays are finally collected by a telescope at E on a photographic plate, or in the eye of the observer. C is a compensating glass plate, so placed that the two beams reflected by M_1 and M_2 have to traverse the same thickness of glass.

The interference phenomena observed in E are of the same kind as those given by thin films (see p. 25). The observer sees the mirror M_1 and the image in M of the mirror M_2 , so that the arrangement is equivalent to a film, one face of which coincides with M_1 and the other with the image of M_2 . The whole interference effect depends on the difference of optical path of the two beams reflected by M_1 and M_2 respectively.

The apparatus enables wave-lengths to be compared with standards of length, thus furnishing an *absolute measure* of wave-length. For this purpose it is only necessary to make the mirror M_1 displaceable and to bring it into coincidence in turn with the two limiting planes of the standard of length. The displacement of the mirror produces a shift of the interference fringes from which the relation between the distance traversed by the mirror and the wave-length can be deduced.*

In this way Michelson in 1893 made a *direct comparison of the metre standard* with the wave-length of the red cadmium line ($\lambda = 6438.4696 \text{ \AA}$).

Nowadays in scientific laboratories and industrial testing rooms it is customary to employ *optical methods* for controlling calibrations (the use of standard length gauges of high accuracy being too costly and difficult). The basic principle is that the wave-lengths of known radiations represent *standards of length* which are invariable and easily reproduced in any laboratory. The thickness to be tested is measured with an interferometer and then Michelson's result, obtained with the metre standard, is applied. The precision obtainable in this way is about 0.0002 mm., which is more than sufficient for practical purposes (in precision mechanical work minimum tolerances are of the order of 0.001 mm.).

Doppler Effect

The whistle of a locomotive has a lower pitch when receding from the listener and a higher pitch when approaching. A similar effect occurs with light waves. Given a source and an observer in relative motion, the number of vibrations received by the observer per second will depend on the relative velocity.

Doppler in 1842 announced this result for the acoustic case. Some years later Fizeau extended it to luminous vibrations. If a line in the spectrum of a luminous source, e.g., a star, is being observed, the effect will be a displacement of the line, that is, an apparent change in the frequency. It is clear that if the source is approaching the observer with velocity V, the frequency observed ν' will be related to the true frequency V by the equation

$$\nu' = \nu \left(1 + \frac{V}{c} \right) \dagger$$

where c is the velocity of light. If the source is not moving directly towards the observer, but in some arbitrary direction in space, then as far as the effect

* In practice, instead of displacing the mirror, use is made of the anterior specular surface of the calibrating length gauge, which takes the place of the mirror.

† A similar relation is evidently true for the wave-length.

under discussion is concerned it is only that component of the velocity which is obtained by projecting on to the line observer—source, which need be taken into account.

As c , the velocity of light, is enormously greater than velocities realisable experimentally in the laboratory, the verification of the Doppler-Fizeau principle was first obtained from astronomical observations. We shall, however, come across another important verification in the kinetic theory of gases.

As an application of the Doppler effect we shall show how it has been possible to evaluate the *rotation of the sun*. If the spectra of the eastern and western extremities of the sun's disc are photographed simultaneously on the same plate, the lines of the eastern extremity appear displaced towards the violet with respect to those of the western extremity. Using the equation

$$\frac{\Delta\lambda}{\lambda} = \frac{V}{c}$$

and the known value of the displacement $\frac{\Delta\lambda}{\lambda} = \frac{1}{150,000}$, it is found that the east side is approaching the earth with a velocity of about 2 km./sec.

In this way Adams and others have been able to explore the *period* of rotation of the sun, which, strangely enough, is not constant. At high latitudes the sun rotates less rapidly. The sun does not rotate like a solid body, the equatorial regions showing with respect to the remainder a marked acceleration. Actually the careful study of sunspots had already brought to light this curious state of affairs.

Structure of the Emission Spectra of Various Sources. Spectral Analysis

The spectra of the light obtained from different sources are either *continuous*—when there exists an infinite continuum of wave-lengths each with its appropriate energy—or *discontinuous*, that is, formed of separate lines, which in certain cases can be resolved into component lines by the use of spectroscopes of high resolving power.

Discontinuous spectra are obtained from matter in a dilute state, *i.e.*, from gases and vapours. Heated solids and liquids give, in general, continuous spectra, as also do highly compressed gases. Thus a continuous spectrum is obtained for the light emitted by a lamp filament, the carbon of an electric arc (incandescent solids) and molten metals (incandescent liquids). Oil lamps also give continuous spectra, the light issuing from the carbon particles suspended in the flame. A gas or vapour can be rendered luminous in several ways. A fragment of a volatile salt introduced on a platinum wire into the Bunsen flame imparts to the flame a colour which depends on the salt used, and analysis of the emitted light yields the characteristic spectrum of the metal contained in the salt. Everyone knows, for example, that sodium gives a yellow light, the spectrum of which contains two lines, very near together at $\lambda = 0.5896$ micron and $\lambda = 0.5890$ micron; the salts of thallium give a green line, and so on. For less volatile metals we can work with the electric spark passed between two wires of the metal under examination, by the aid of an induction coil. The spectrum of iron containing an enormous number of lines is obtainable in this way. When the substance is a gas at ordinary temperatures, like oxygen, hydrogen, etc., it is made luminous by passing an electric discharge through a tube containing the gas at low pressure (a few millimetres of mercury). Thus hydrogen gives a spectrum of four lines :

$\lambda = 0.656$ red ; $\lambda = 0.486$ blue ; $\lambda = 0.435$ indigo
 $\lambda = 0.410$ violet (λ in microns).

The observations of Donati, Secchi and their contemporaries, on the light from the stars were made by direct vision, the stellar spectrum, characterised by absorption lines, being compared with an emission spectrum of a terrestrial source in the laboratory. To Vogel (Potsdam) we owe the great improvement in technique obtained by placing a photographic plate at the focus of the astronomical telescope and photographing together the stellar spectrum and the comparison spectrum. In this way the *spectrograph* had its origin, the photographs obtained (spectrograms) being examined with auxiliary apparatus. These spectrograms give us invaluable information concerning the chemical constitution of the stars, their temperature, radial velocity and stage of evolution.

The solar spectrum has been photographed from $\lambda = 3,000$ Ångström (violet) to about $\lambda = 10,000$ Ångström in the red, and ten million lines have been catalogued.

When light emitted from a solid substance, and therefore having a continuous spectrum, passes through a gas at a lower temperature the latter exerts a selective absorption. The gas absorbs the radiations which it is able to emit, so that in the light transmitted dark lines appear in the positions of the emission lines of the gas when it is self-luminous.

On the other hand, if the gas is at a ~~lower~~ higher temperature than the solid source, its characteristic lines are intensified.

It is in this way that the Fraunhofer lines in the solar spectrum are produced by the gaseous layer of the photosphere.

The solar spectrum, as obtained by terrestrial observers, contains the so-called *earth lines*, which are due to absorption by the earth's atmosphere before the light reaches the spectroscope. Lines (grouped into bands) due to oxygen, water vapour and carbon dioxide, are observed in this way. The earth lines are distinguished from those of solar origin by their variability with the altitude of the sun, being more intense when the light, arriving horizontally, has to traverse a greater thickness of air. They are also recognisable from the fact of being identical whether observed at the centre of the sun or at the edge. In addition, they fail to show the Doppler displacement due to the rotation of the sun.

The Triumphs of Spectroscopy

We shall review briefly the achievements of spectroscopy, as an introduction to later developments.

Spectroscopy has enabled the presence of a metal in a substance to be recognised. To this end the vapour of the substance is made luminous and its spectrum is examined to see if it contains the lines of the metal sought. This method of chemical analysis is extraordinarily sensitive, less than a ten thousandth of a milligramme of the substance being sufficient for the observation of its flame spectrum.

Spectrum analysis made possible the discovery of the elements cæsium, rubidium, gallium, etc., and Lockyer, in 1868, by examining the spectrum of the solar prominences was led to the discovery of helium. The composition of all the stars has been investigated. These researches were due in the first place to G. B. Donati (1860), and were prosecuted with great success by Padre Angelo Secchi (1810-78). Spectrum analysis has established the unity of composition of the universe.

With the introduction of the spectroscope the Doppler-Fizeau principle has also proved fruitful in astronomy. Ordinary astronomical methods only

allow us to determine the lateral displacements of the stars on the celestial sphere, and tell us nothing about the motion of stars which are approaching or receding from the earth. The Doppler effect supplies us with a means for ascertaining these motions. From the lateral velocity, given by ordinary methods, and the radial velocity given by the Doppler-Fizeau method, the true velocity of the star with respect to the earth, and hence with respect to the solar system, can be determined.*

Spectroscopic examination of the light emitted by the stars informs us of their temperatures. A simple method, based on a general principle, is to compare the stellar spectrum with the spectra of the various elements in sources of increasing temperature—oxy-hydrogen flame, electric furnace, electric sparks of increasing intensity. The ratio of the intensities of two lines in the light emitted by the star varies with temperature according to a definite law, and in this way the temperature can be calculated.

The above sketch is sufficient to give an idea of the importance of spectroscopy, but there is yet another interesting application which opens up almost incredible possibilities. Spectrograms enable us to determine the distance away of the stars by examination of the relative intensities of the same line emitted by stars belonging to the same spectral class (that is, stars having the same surface temperature).

Thales and Maxwell

Thanks to Fresnel, Young, Arago and others, optics made rapid strides in the past century, but it was left to Maxwell (1831-79) to transform the science into a branch of electromagnetism.

In the history of science the chapter on electricity is almost a blank until the commencement of the last century. From the Greeks at the time of Thales (650-540 B.C.), who knew that amber when rubbed attracted light bodies, we pass immediately to A.D. 1600, when Gilbert, physician to Queen Elizabeth, observed that glass and other substances had the same property. Then we come to Benjamin Franklin, who, in about 1750, advanced an ingenious hypothesis as to the nature of the electric fluid, which Aepinus modified. Who was this Carneade, who gave his name to a rudimentary condenser? He was professor at the University of St. Petersburg in about 1790. Electrotechnics was included among his subjects of instruction, but we realise that he must necessarily have disposed of the subject in a very few lectures.

At the time of Aepinus only electrostatics was known, that is, put briefly, the production of electricity by friction, the power of points, condensers, several frictional machines, atmospheric electricity. However, attempts had been made by Franklin and by Aepinus himself to co-ordinate all the facts then known, before Aepinus ventured to propose, by analogy with what was known about universal gravitation, that electrical effects varied inversely as the square of the distance between the bodies concerned.

In Franklin's theory of the electric fluid are contained the first glimmerings of the hypothesis of the granular structure of electricity. It is certain, however, that for Franklin the matter was just as obscure as in the case of Democritus and his speculations on the atomic theory of matter.

As a whole, the history of electrical theory up to the end of the nineteenth century comprises two main periods. In the first, with which the name of

* The first astronomer to employ this powerful method was Huggins (1824-1910), who in 1867 measured the displacement of the F line of hydrogen in the spectrum of Sirius. Twenty years later Vogel improved the precision of such measurements by using spectrograms, *i.e.*, photographs of the spectrum.

Coulomb is particularly associated, the essential idea is that of electric charges acting at a distance, in the same way as masses in gravitational theory. The second period commences with Faraday (1791–1867), who refused to admit the possibility of action at a distance, and drew attention to the medium through which the effects were transmitted. Faraday absolutely rejected the strange idea, which nobody now holds, of an instantaneous action at a distance, and he also rejected the hypothesis of the two electrical fluids, which endowed the notion of charge with concrete reality.

The fundamental notion thus becomes the intensity of the field, a vector magnitude which characterises the state of the medium at each point. Electric charge appears only as a secondary notion, because the quantity of electricity carried by a body is determined solely by the number of lines of force which terminate on the body. It was Faraday who discovered (1831) the phenomenon of self-induction, that is, induction produced in a circuit by increasing or diminishing the current in the circuit itself. Oersted, eleven years previously, had observed the deflection of a magnetic needle by an electric current, and had shown that in the space surrounding the latter there exists a magnetic field. These phenomena and the laws governing them form the foundations of the electromagnetic theory, of which the central ideas were provided by Faraday, and which Maxwell rendered precise and developed into a mathematical theory which is one of the greatest achievements of the human mind.

Maxwell (1831—1879), Hertz (1857—1894)

An electric current in a circuit produces in the surrounding medium lines of magnetic forces which encircle the conductor. Furthermore, any change in a magnetic field in which there is a closed metallic circuit, gives rise to an electric current, indicating the production of an electric field whose lines of force encircle in like manner the magnetic force lines. Maxwell conceived the idea that in the absence of a conductor, in a vacuum or in any dielectric, variations of the magnetic field, both in intensity and in direction, generate electromotive forces, giving rise to what he called *displacement currents*. These displacement currents have properties similar to those of ordinary currents which circulate in conductors and like these produce magnetic fields and generate induction effects.

For Faraday's idea of tubes of force Maxwell substituted the more precise notion of flux of induction through a surface, the induction being a vector proportional to the field, the factor of proportionality varying according to the nature of the medium. The electric charge contained in a closed surface is defined in Maxwell's theory simply as a magnitude proportional to the total flux of induction from the interior to the exterior of the surface.

In a medium traversed by a perturbation two modifications are superposed characterised respectively by two vectors, the electric field E and the magnetic field H to which correspond the electric induction ϵE and the magnetic induction μH . The two constants ϵ and μ are termed respectively the *dielectric constant* and the *permeability*.* Each of the two fields involves a localisation of energy in the medium. The total amount of energy per unit volume equals $\frac{\epsilon E^2}{8\pi} + \frac{\mu H^2}{8\pi}$, the first term representing electrical, the second magnetic energy. Each of the fields can vary from point to point, and at a given point from one instant to another. Maxwell established the laws

* These constants indicate by how many times the electric or magnetic force in the medium is reduced compared with the values which they have in the same circumstances *in vacuo*.

expressing the interdependence which exists between the two fields, or rather, between their variations in space and time.

Expressed precisely, if we take a closed contour in space where variations in magnetic field are occurring, then the electromotive force generated along this contour is equal to the variation per unit time of the magnetic induction across any surface bounded by the contour. Maxwell, by a brilliant intuition, lighted on the law correlative to the above, the *law of the displacement current*.

These two correlative relations expressed in mathematical language form the starting-point of the entire electromagnetic theory, the prodigious structure which has made Maxwell's name immortal. Boltzmann, in the introduction to his book on the theory, sums up his admiration for Maxwell's astounding achievement with the remark "*Ist es ein Gott der diese Zeichen schrieb ?*" *

An electromagnetic disturbance, such as is produced by imposing on an electric charge a rapid oscillatory motion, corresponds to the production of an electric field and a magnetic field at right angles to each other and to the direction of propagation. In addition, these two fields have intensities such that at a given point *in vacuo* they represent the same energy per unit volume.

Every electromagnetic disturbance is propagated in all directions with a definite velocity. It is easy to see that this propagation results directly from the mutual generation of the two fields, which recurs from place to place. The velocity of propagation depends, in virtue of the laws stated above governing the mutual generation of the two fields, upon the two coefficients ϵ and μ through the relation,

$$v = \frac{c}{\sqrt{\epsilon\mu}}$$

ϵ = dielectric constant.

μ = permeability.

c = ratio between the electromagnetic and electrostatic units.

Thus, Maxwell's calculations lead to a result of immense importance; the quotient of the electromagnetic unit of current by the electrostatic unit is equal to the velocity of propagation of electromagnetic disturbances *in vacuo*. The intensity of a current can be measured by two different principles, based respectively on the quantity of electric charge transported in unit time and on the magnetic field created by the current in the surrounding space. To these two methods of measurement correspond two systems of electrical units, the electrostatic and the electromagnetic systems.

A given quantity of electric charge is represented by different values in the two systems, and the ratio of these is not a pure number, as, for example, the ratio of the metre to the foot, but has the dimensions of a velocity, *i.e.*, it varies with change in the units of length and time in the same ratio as a velocity.

According to Maxwell's calculations, the ratio in question should equal the velocity of propagation of electromagnetic disturbances *in vacuo*. Before Maxwell had arrived at this remarkable result, direct measurements of the velocity of light had been made, and in 1853 W. Weber † had succeeded

* Is it God or man who has written this ?

† Weber and Kohlrausch measured with an electrometer the charge of a *Leyden jar* in electrostatic units, and then passed the discharge current through a ballistic galvanometer to determine the total quantity of electricity (as time integral of the current) in electromagnetic units.

Lord Kelvin (1869) found for the ratio of the units 2.82×10^{10} , Rowland (1889) 2.98×10^{10} , Abraham (1890) 2.991×10^{10} , Rosa and Dorsey (1907) 2.997×10^{10} .

in determining the ratio of the two units of current (or of charge for which the ratio is the same). He had obtained a result which within the limits of experimental error, agreed with the velocity of light.

Thus, not only are electromagnetic waves transverse like light waves, but their velocity of propagation is the same. This agreement naturally led Maxwell to identify the two phenomena, and to assume that light consists of electromagnetic waves propagated in the ether.

What then is the ether? The ether of space is a medium capable of assuming certain modifications which are termed electromagnetic fields. It differs from the pure space of geometry in possessing physical properties, which are revealed by its constants (gravitational, electric and magnetic). It is capable of propagating light with a definite velocity which depends on the values of these physical constants.

For about twenty years Maxwell's great work was imperfectly understood and appreciated by his contemporaries. It was Heaviside who transformed the theory into a lucid and coherent whole, divested of unnecessary complexities introduced by its originator.

Maxwell's theory was fully confirmed by the experiments initiated by Hertz in 1887 at the Polytechnic in Karlsruhe. These experiments were concerned with oscillatory discharges producing periodic electromagnetic disturbances. The period of oscillatory discharge depends on the experimental arrangement, and is equal to $2\pi\sqrt{LC}$, where C is the capacity and L the inductance of the circuit. Hertz succeeded in generating one metre waves, and measured their wave-length. He showed that these electromagnetic waves were completely analogous to light waves, that they had the same velocity of propagation, and could be reflected, refracted, polarised and made to interfere.

After these classical experiments it proved possible to obtain waves of a few millimetres wave-length. Remembering that in the infra-red region of the spectrum, rays with a wave-length of half a millimetre have been observed, it is clear that there is no break between these and the waves produced by the electric discharge.

Between ordinary light waves and the waves observed by Hertz, which have ten million times the wave-length, there is no discontinuity or true difference in quality. Electromagnetic waves, heat waves and light waves are the same phenomenon in different scales of frequency. Beyond the ultra-violet rays, with wave-lengths of four ten thousandths of a millimetre, come the Holweck rays and beyond these the X-rays, which by themselves cover a vast range. Hertz worked with waves several metres in length, but to-day the waves employed in radiotelegraphy are measured in kilometres.

We shall conclude this brief sketch with a statement of Maxwell's equations of the electromagnetic field.

Equations (1) and (2) express in mathematical form the correlation of the two fields in space and in time to which we referred above. X, Y, Z are the components of the electric force, L, M, N, the components of the magnetic induction, w_x, w_y, w_z the components of the velocity of the electric charge of density ρ .

All these magnitudes are functions of position (x, y, z) and time t . c is the velocity of light.

$$-\frac{1}{c} \frac{\partial L}{\partial t} = \frac{\partial Z}{\partial y} - \frac{\partial Y}{\partial z} \quad \dots \quad (1)$$

and two similar equations.

$$\frac{1}{c} \left(\frac{\partial X}{\partial t} + 4\pi\rho w_x \right) = \frac{\partial N}{\partial y} - \frac{\partial M}{\partial z} \quad \dots \quad (2)$$

and two similar equations.

only need to consider sinusoidal variations of the vector \mathbf{E}_y . By integration of (1') and (2') subject to this restriction, it is easy to establish* that \mathbf{E} and \mathbf{H} are transmitted with velocity $v = c/\sqrt{\epsilon\mu}$, \mathbf{E}_y assuming the form

$$\mathbf{E}_y = A \sin \left[\frac{2\pi}{\lambda} (x - vt) + \alpha \right].$$

α is the phase and is unimportant. λ is the wave-length.

Using this result and equation (1') we obtain

$$\mathbf{H}_z = \frac{\epsilon v}{c} A \sin \left[\frac{2\pi}{\lambda} (x - vt) + \alpha \right]$$

In *vacuo*, $\frac{\epsilon v}{c} = 1$, and hence $\mathbf{E}_y = \mathbf{H}_z$. Thus, in a vacuum the intensities

of the electric and magnetic fields are the same. In a material medium, however, the ratio of these two vectors is the index of refraction of the medium for the light waves concerned. This follows since μ is almost equal to unity, and we have

$$\frac{\mathbf{E}_y}{\mathbf{H}_z} = \frac{\epsilon v}{c} = \frac{\epsilon c}{c\sqrt{\epsilon\mu}} = \sqrt{\epsilon} = n.$$

The magnitude A appearing in the expressions for the two vectors \mathbf{E} and \mathbf{H} is termed the *amplitude*. The *luminous intensity*, on the other hand, denotes the energy crossing unit area of the surface normal to the direction of propagation per unit time. The energy per unit volume we know to be

$$\frac{\epsilon \mathbf{E}_{\text{mean}}^2}{8\pi} + \frac{\mu \mathbf{H}_{\text{mean}}^2}{8\pi}$$

where $\mathbf{E}_{\text{mean}}^2$ and $\mathbf{H}_{\text{mean}}^2$ represent time averages.

The velocity of propagation is v , and hence the quantity of energy passing in unit time, *i.e.*, the luminous intensity, is given by

$$\mathbf{I} = v \frac{\epsilon \mathbf{E}_{\text{mean}}^2 + \mu \mathbf{H}_{\text{mean}}^2}{8\pi}$$

Finally, remembering that both \mathbf{E} and \mathbf{H} vary sinusoidally with the time, their mean values are respectively

$$\frac{A^2}{2} \quad \text{and} \quad \frac{\epsilon^2 v^2 A^2}{c^2 2}$$

Hence,

$$\text{luminous intensity } \mathbf{I} = \frac{\epsilon v}{16\pi} A^2 = A^2 \frac{c}{8\pi} \sqrt{\frac{\epsilon}{\mu}}.$$

The luminous intensity is proportional to the square of the amplitude.

In *vacuo*, the intensity \mathbf{I} is simply $\frac{A^2 c}{8\pi}$, and for unpolarised light $\frac{A^2 c}{4\pi}$.

From (1') and (2') we obtain

$$\frac{\partial^2 \mathbf{H}_z}{\partial x^2} = \frac{\epsilon \mu}{c^2} \frac{\partial^2 \mathbf{H}_z}{\partial t^2} \qquad \frac{\partial^2 \mathbf{E}_y}{\partial x^2} = \frac{\epsilon \mu}{c} \frac{\partial^2 \mathbf{E}_y}{\partial t^2}$$

These are the general equations of a vibrating system, which will be discussed in Vol. II., Chap. VIII.

Anomalous Dispersion

To explain dispersion * a model of the constitution of matter, in agreement with the facts of observation, has been devised in which the atom is represented as a system of particles held in equilibrium by elastic forces. These are forces which hold the particle (the electron) to its equilibrium position with an intensity proportional to the instantaneous displacement. Let m and e be respectively the mass and charge of the particle. The harmonic vibrations which the particle executes when made to vibrate by a periodic field are *forced* by the alternating field, which in general has not the same period as that appropriate to the freely oscillating charge. The whole system is defined, knowing e and m and the constant K of the restoring force (K is the restoring force for unit displacement). Elementary mechanics gives for the period of free oscillation,

$$T = 2\pi \sqrt{\frac{m}{K}} \text{ and, for the frequency, } \nu_0 = \frac{1}{2\pi} \sqrt{\frac{K}{m}}$$

By calculation, the law of displacement of the charge can be found. Applying this problem to the consideration of the electrons in the atom, which are set in vibration by light waves (sinusoidal field), the complete law of oscillation of the electron can be obtained.

The displacement y is given by

$$y = \frac{eE}{4\pi^2 m (\nu^2 - \nu_0^2)}$$

ν is the frequency of the field E , for which we have

$$E = E_0 \cos(2\pi\nu t + \alpha).$$

If \mathcal{N} is the number of particles in unit volume, $\frac{ey\mathcal{N}}{E}$ represents the polarisability p ,† and this is related to the dielectric constant by the simple formula $\epsilon = 1 + 4\pi p$. Since the refractive index $n = \sqrt{\epsilon}$, we are able finally to express the refractive index of a substance in terms of the two frequencies ν and ν_0 . The result obtained takes the following form :—

$$n = \sqrt{\epsilon} = \sqrt{1 + \frac{e^2 \mathcal{N}}{\pi m (\nu_0^2 - \nu^2)}} \dots \dots \dots (\perp)$$

The above theory is only to be regarded as an approximation, because the electrical particles—closely packed as they are in the substance—disturb each other's oscillations, and hence the result (\perp) is valid only for gases, and then only to a first approximation. The second term under the square root sign is always very small for gases, and their refractive indices are all very nearly equal to unity. If, however, the incident light has frequency ν almost equal to ν_0 , the term in question can become very large, and the refractive index will then be considerably different from unity, tending theoretically to infinity. When we investigate the variation of refractive index for light of frequency in the neighbourhood of that which an element can emit, an anomalous behaviour is observed to which the term *anomalous dispersion* is applied. There is marked absorption and, in addition, the rate of change

* *Dispersion* is the fact that different monochromatic radiations have different refractive indices, so that a pencil of mixed light, passing from one medium to another, is spread out like a fan.

† The polarisability of a dielectric is the coefficient of proportionality between the electric moment per unit volume and the external field.

of refractive index with wave-length is very rapid on either side of the absorption band. There is a rapid transition from a very small value of the refractive index (for light of slightly lower λ_0) to a very high value (for light of slightly higher λ). (Actually the branches of the refractive index curve do not go to infinity for $\nu = \nu_0$, because the oscillators are damped.)

The value of the refractive index, although it should tend to infinity when the frequency ν approaches ν_0 from below, may drop below unity when ν exceeds ν_0 , that is, for light of very high frequency. Thus if, for the substances of which prisms for optical instruments are commonly made, the characteristic frequency is situated in the ultra-violet, then for very high frequencies it should be possible to show experimentally that the index is less than unity. The rays should be deviated in the sense opposite to that usually observed, towards the vertex of the prism instead of towards the base.

This was found to be the case by Siegbahn in 1925, for X-rays passed through a prism of aluminium (Chap. VI.).

For X-rays ν is very large with respect to ν_0 , and with sufficient accuracy we may write,

$$n = 1 - \frac{e^2 \mathcal{N}}{2\pi m \nu^2}$$

and it is clear that the index n is less than 1.

We shall return to this subject in Vol. II., Chap. VIII., to show that the phenomenon of refraction is also governed by quantum theory considerations.

General Properties of Radiation

As we have seen, it was established that the different radiations, known as ultra-violet rays, light rays, infra-red rays and Hertzian waves, all have the same character. By the end of the century to this series of ether vibrations were added X-rays and γ -rays, as a result of Röntgen's discovery and the discovery of radioactivity. The *cosmic rays* have still higher frequency.

All these radiations are propagated *in vacuo* with the velocity 300,000 km. per second. All undergo reflection, refraction, diffraction, and can be polarised, in obedience to the same laws. All these rays of different types when incident on a body exert a pressure, which is termed the *pressure of radiation*. If they are absorbed their energy is transformed into heat. All give rise to interference effects, which establish their periodic character and enable the respective wave-lengths to be calculated. They differ only in frequency, each monochromatic radiation being characterised by a well-defined frequency value. No experiment, however, gives a direct measure of the frequency. It is for this reason that electromagnetic or, in a general sense, light waves are characterised by giving the wave-length, which can easily be measured.

Since $\lambda = \frac{\text{velocity}}{\text{frequency}}$, the wave-length λ depends on the velocity of propagation which varies with the medium concerned. λ is therefore defined for propagation *in vacuo* where all the radiations have the same velocity of propagation, the value of which is accurately known. In any other medium of refractive index n for a given monochromatic frequency, the velocity of propagation becomes $\frac{300,000}{n}$.

The following table includes all the known electromagnetic radiations, classified in order of decreasing wave-length :—

Hertzian waves . . .	Wave-length from kilometres to 1 mm.
Infra-red . . .	1 mm. to 0.75 micron.
Visible light . . .	0.75 micron to 0.40 micron.
Ultra-violet . . .	0.40 " 0.18 "
Schumann rays . . .	0.18 " 0.12 "
Lyman rays . . .	0.12 " 0.05 "
X-rays . . .	5×10^{-6} cm. to 5×10^{-9} cm.
γ -rays . . .	less than 10^{-10} cm. †

(1 micron = 1 thousandth of a millimetre, 1 millimicron = 1 millionth of a millimetre.)

The total amount of energy transported per second in a beam of radiation is evaluable in watts, but the luminous flux, which is determined by the capacity of the radiation to produce the sensation of light, is expressed in *lumens*. The lumen is so defined that the total luminous flux from a source of one *candle* has the value 4π lumens. For light of a given colour the luminous flux is proportional to the flux of radiant energy, but the visibility of the radiation (lumens per watt) varies with the wave-length and is a maximum in the green.

The *illumination* of a surface is given by the number of lumens incident per square metre, and has the value *unity* when the surface is distant 1 metre from the standard candle.

The *lambert* is the unit of brightness of a surface, and has the value 1 when 1 lumen is emitted per square cm.

The *albedo* of a reflecting surface is the ratio between the total luminous flux reflected and that incident, and is always less than unity.

The Pressure of Light

Reference has been made in passing to the fact that light exerts a pressure on any surface on which it is incident, in the same manner as a bombardment of material particles. This was established almost simultaneously by Maxwell and Bartoli. The former based his calculation on the electromagnetic theory of light, while Bartoli worked from Carnot's principle or the second law of thermodynamics.

We shall give only the result; the proof in any case presents no difficulty. The ideas involved, which thirty years ago were wrapped in obscurity, now appear very ordinary. Science, as it advances, clarifies and smooths away complexities; results obtained originally with great difficulty yield later to simple and concise reasoning.

The density of energy in the incident beam appears in the result. Every radiation, whether luminous to our eyes or not, is convertible into heat, and represents therefore energy. A totally absorbing surface receives a certain amount of radiational energy per unit time per square centimetre. As the radiation traverses in unit time 300,000 kilometres, it is clear that in a cylinder of one square centimetre base and 300,000 kilometres high, is contained the energy absorbed per unit time per unit area. Thus, dividing the latter quantity by 3×10^{10} we obtain the energy density.

The pressure of light p on a perfect reflector is always normal to the surface, and is calculated to have the value

$$p = u \cos^2 i$$

where u is the energy density in the neighbourhood of the reflecting body, due both to the incident and the reflected radiation, and i is the angle of incidence. If the body is not perfectly reflecting, the pressure is no longer normal to the surface unless the radiation is itself incident normally.

The forces involved are extremely small. The pressure of solar radiation on a black absorbing surface, at midday and when the sky is clear, is only half a milligramme per square metre. Nevertheless, by extremely delicate experiments a number of physicists have succeeded in measuring the pressure exerted by a light beam, and have verified that it agrees in amount with the theoretical value.

Although the pressure of radiation seems too small to produce appreciable effects, it actually determines the form of comets' tails, and assumes extremely high values in the interiors of the stars, on account of the colossal temperatures obtaining there.

The existence of radiation pressure allows us to speak of the *momentum of electromagnetic radiation*, and hence of the *mass of radiant energy*, where by mass is meant capacity to carry momentum. We know from ordinary mechanics that in general for normal incidence the pressure exerted is equal to the momentum received per second. This momentum for radiational energy is contained in a cylinder of base 1 cm.^2 and height equal to the velocity of propagation. In the case of electromagnetic waves with incident density W , the momentum per $\text{cm.}^2 \text{ G}$ is defined by $W = Gc$.

Theory of Lorentz

Maxwell's theory consisted primarily of a system of equations and left many questions unanswered. It did not elucidate the problem of the mechanism of light emission, took no account of the laws of electrolysis, and explained neither the dispersion of light nor the double refraction of crystals, and rotatory polarisation. Thus, while the laws relative to a vacuum, *i.e.*, the ether, were simple and characterised by a single velocity of propagation equal to 300,000 km. per sec., the properties of matter proved to be much more complicated. The velocity of light depends on numerical coefficients characteristic of the material medium, and moreover, even in the simplest case of sinusoidal waves, it varies with the frequency. If we are not content merely to introduce these coefficients into the equations, assigning to them values derived from experiment, and if we wish to penetrate more deeply into the nature of the phenomena, Maxwell's theory is not sufficient.

It was Lorentz who made the further advance (1895) in an attempt to interpret the interrelations of matter and ether. Lorentz assumed the existence—in all bodies—of negatively charged particles, much smaller than the atoms, the movements of which enable us to explain optical and electrical phenomena. It was an obvious step to identify the amount of their charge with that carried by electrolytic ions. Hence the name electrons, by which the particles are known.

Insulators, or dielectrics, contain, according to Lorentz, only electrons bound to atoms and incapable of being detached therefrom. When, under the action of an external electric field, these bound electrons are displaced, a force is called into play which tends to oppose the motion and limits the amount of displacement. Immediately the electric field is removed the electrons resume their normal positions.

In addition to the *bound electrons*, metals contain *free electrons* which move about in the inter-atomic space at random like the molecules of a gas.

The principal properties of metals are interpreted without difficulty on this hypothesis, *e.g.*, their thermal and electrical conductivities are explained. An electric current in a conductor is a flow of particles set in motion in a particular direction by an electromotive force which is superposed on the disorganised motion of the particles in the absence of a field.

The conductivity of a metal, electrical or thermal, is increased the more

free electrons there are, the greater their velocities and the longer the mean free path between consecutive collisions with atoms. The energy transmitted to the atoms against which the electrons collide, is the cause of the heat generated in the passage of the current. The kinetic energy of the electrons, like that of the atoms, increases with temperature, and we can understand therefore the observed parallelism between electrical and thermal conductivity, the metals which are good conductors of electricity being, as a rule, those which best transmit heat.

The theory enabled derivations to be made of various quantitative laws, such as those of Ohm and Joule, relating to the resistance to current flow and the heat developed, and the empirical relation of Wiedemann and Franz, according to which the ratio of the thermal to the electrical conductivity at a given temperature is the same for all metals, the value of the ratio being proportional to the absolute temperature.

Each electron in its path may be regarded as a current. The magnetic field, in the space surrounding a conductor, is the sum of the magnetic fields due to these elementary convection currents. Thus, an external magnetic field acts on the metal through the intermediary of its free electrons. The trajectory of each electron is deviated, with the result that a certain difference of potential appears between one pair of opposite sides of a rectangular plate when a current is passed between the other pair. (*Hall effect.*)

If the thermal agitation of the electrical particles in the metal is sufficiently violent, the electrons may be ejected. Thus, at high temperatures electron emission becomes appreciable. This is the *Edison effect*.

Without entering into further details, we may say that the theory gave excellent qualitative results and explained many phenomena *in general terms*. However, difficulties were met with in attempting to obtain numerical verification. For example, the Wiedemann-Franz law no longer holds, even approximately, at low temperatures, and the theory was impotent to provide an explanation. Recently a great improvement has been effected in the theory, to which we shall return in Vol. II., Chap. IX.

CHAPTER III

THE KINETIC THEORY OF GASES

The Internal Structure of Gases

A GAS is considered to be composed of a very large number of independent particles, moving freely within the vessel containing the gas.

It is assumed, as a first approximation, that these particles are spherical in shape and have equal masses, and that their total volume is negligible in comparison with that of the containing vessel; they are corpuscles situated in a free space which is of enormous size in comparison with their dimensions.

In a gas the molecules move almost entirely as a result of their action on one another, cohesion being very small or absent and the movements being practically in straight lines and undeflected except by the continual impacts which each molecule undergoes, either by collision with other molecules, or by contact with the walls of the containing vessel.*

The theory of matter in the gaseous state is therefore easier to develop than that of the other states on account of the absence of the forces of cohesion which play an essential part in solids and liquids; further, the fact that the distances between the molecules are large compared with molecular dimensions brings about—both in the theory and in the calculations based upon it—important simplifications which are the more justifiable the smaller the degree of compression of the gas, *i.e.*, the more closely the state

* According to modern theories, which have not yet been applied in detail to the theory of gases, this conception of the impacts as true collisions between elastic spheres has not much meaning, because the molecules, consisting of particles electrically charged, repel each other, and an encounter between them is only an approach sufficiently close to bring into play repulsive forces of electrical origin.

considered approaches that of a perfect gas which obeys the *ideal* laws of Boyle and of Gay-Lussac.

It has been shown experimentally that gases have weight, that they dilate to fill the whole of the space open to them, and that they are compressed as the pressure to which they are subjected is increased. From these known facts a *model* of a gas can be constructed, and Daniel Bernouilli in 1738 showed that a system of minute particles at great distances from each other, having weight and endowed with high velocities in all directions, gave a theoretical basis for the Boyle-Mariotte law, as, indeed, is almost self-evident.

To Bernouilli's original conception there were added, a century later, the experimental studies of Volta, of Joule (1848), of Krönig (1856), and of Clausius (1857). Finally Maxwell (1859), the great mathematician, was induced by the study of Saturn's rings to consider the kinetics of gases, and so to give the complete analytical theory of the subject. Some slight uncertainties and imperfections remained to be removed, and a number of eminent physicists applied themselves to the task, the most eminent among them being Boltzmann, Kirchhoff, Van der Waals, Jeans, Lorentz and Lord Rayleigh, all of them worthy successors in the prosecution of Maxwell's work.

Distribution of Velocities in the Molecular Random Arrangement

The molecules composing a gas are considered, then, as material particles all equal, rigid and perfectly elastic; their dimensions are extremely small and negligible compared with the distances between them; there is no sensible force of cohesion between them, and they do not, therefore, act on one another except by mutual impact. The movements of these particles continue to be uniform and in a straight line until they come sufficiently close to be deflected by their mutual action or by impact; at the instant at which an accidental collision takes place, the velocities of the particles concerned undergo sudden changes both in magnitude and direction.

All the trajectories must, then, be represented as irregularly broken lines, each element being practically straight.

The form and the structural details of the molecules naturally depend on the chemical nature of the gas under consideration ; in a gaseous mixture the molecules will be of two or more kinds ; the translatory movement, moreover, does not—in general—exclude movements of the molecule about its centre of gravity or *internal* movements of the various parts of a single molecule with respect to one another.

When a gas enclosed in a motionless vessel which is maintained at a uniform temperature is left to itself, it takes up a steady state and in this condition equal volumes contain equal numbers of molecules ; such minute fluctuations of density as there may be are quite inappreciable if we consider a volume of the order of one cubic centimetre, although they may, perhaps, be just appreciable, as we shall see, in a cubic micron. If n_0 be that number of molecules which will occupy a certain volume when the whole vessel has acquired a uniform distribution, and if n be the actual number of those which at a certain instant are to be found within that volume, the fluctuation is equal to the ratio $\frac{n - n_0}{n_0}$ which is variable from one instant to another according to the law of probability.

The molecules which at any given instant occupy any small volume, *e.g.*, a millimetre cube, have velocities in all directions, in all senses and of every magnitude ; there is no direction more favoured than any other ; and all this is independent of the position of the small volume which may be mentally selected within the containing vessel.

The conception just described may be otherwise expressed, *e.g.*, it may be said that, for any given portion of the gas, the number of molecules with a certain velocity in any given direction is practically equal to the number having the *same* velocity but in the *opposite* direction.

The gas is, then, in a state of *random molecular arrangement*.

So far there is no difficulty ; the mathematical difficulties of the problem, as Maxwell stated them, arise immediately we propose to

discuss the law according to which the velocities of the molecules, at first sight distributed at random and entirely without order, may be grouped. Let us see how this conception may be made clearer. If we wish to calculate the total kinetic energy of all the molecules, we must find the sum of the values of $\frac{1}{2}mv^2$ for all the molecules, and this sum may be expressed as $\frac{1}{2}MC^2$ where M is the total mass of the gas, and C^2 is the mean of the squares of the velocities of all the individual molecules.

Now, it is true that all the velocities differ among themselves and it is equally true that they vary from one instant to another, but if this velocity is, say, 600 metres per second, how many molecules, out of 100,000, will have velocities lying between 610 and 605 m./sec., how many between 600 and 595, how many between 595 and 590, and so on? In short, is there a law of distribution of velocities, and, if so, what is it?

The credit for its discovery is due to Maxwell; Boltzmann gave further proofs, elaborating and perfecting Maxwell's method; this law is the foundation stone of that important part of physical science, the kinetic theory of gases; kinetics then became what we now recognise it to be, viz., the first step towards the study of the atom.

Maxwell's Law

An example will be useful in making matters clear to the student. A marksman wishes to hit the middle point of a rod fixed vertically in the ground, this point being marked by means of a line at the height H . He fires 1,000 shots and then makes an analysis of his shots and notes all their distances from the mark; there will be 500 within the interval between 10 cm. above and below the mark, 325 in the next interval of one decimetre, and so on. The shots cluster in the neighbourhood of the mark, the heights tend to the fixed value H , and each shot which goes "high" has its counterpart in one which is correspondingly low.

Statistical analysis has shown that there is a law governing this distribution, so that if the same marksman repeats the trial of the thousand shots and makes the same analysis as before, he finds the same numbers again, neglecting small differences. What

happens if a less skilful marksman repeats the trial? All the shots go wider of the mark; but they are known to spread according to a certain law; they are less concentrated, but again their arrangement is in accordance with a law of distribution. In short, we have to do with the problem of errors of measurement, as it is met with in all cases of the determination of any quantity (angle, distance, temperature, etc.).

Maxwell showed that when the state of thermal equilibrium was reached, the magnitudes of the molecular velocities were distributed according to a law which is not affected any more by the subsequent molecular collisions. Let three mutually perpendicular directions be taken as axes of reference, and let n be the number of molecules per cubic cm. The number, dn , of these which have component velocities lying respectively between u , v , w and $(u + du)$, $(v + dv)$, $(w + dw)$ will be

$$dn = n \cdot f(u, v, w) du \cdot dv \cdot dw.$$

The law of distribution of velocities is known as soon as the form of the function f is given.

Let us for the present pass over the calculations in order not to interrupt the progress of the argument, and say at once that Maxwell found:

$$dn = n \sqrt{\frac{h^3 m^3}{\pi^3}} e^{-hm(u^2 + v^2 + w^2)} du dv dw \quad . \quad . \quad (1)$$

where h is a constant,

m is the mass of one molecule,

e is the base of naperian logarithms = 2.7183.*

The expression (1) seems very complicated, but it is not so in reality, as can be demonstrated at once. It contains, necessarily, a constant of the form hm , since for any given gas all the velocities vary with the temperature; thus the number of molecules included in a given interval, defined by $du dv dw$, is not always the same; as an illustration, if an angle is measured by means of two

* The quantity e is the limiting value, when $n = \infty$, of the expression $(1 + \frac{1}{n})^n$.

instruments having different degrees of precision, the percentage of measurements which have errors lying within a given interval is different in the two cases. The meaning of the constant h will be described a little later on.

This expression (1) is homogeneous, *i.e.*, symmetrical with respect to the velocities u, v, w ; the component velocities are distributed equally among the three axes.

The question may now be asked, what number of molecules, from among the n contained within a cubic centimetre, have velocities of which the x -components lie between the limits u and $(u + du)$ all other considerations being ignored ?

This number is, clearly,

$$dn_1 = n \sqrt{\frac{hm}{\pi}} e^{-hm u^2} du \dots \dots \dots (2)$$

Actually, (1) may be derived from (2) by postulating three simultaneous conditions for the velocity of a molecule, *viz.*, that the component of the velocity along the x -axis shall lie between u and $(u + du)$, that the second velocity component shall lie between v and $(v + dv)$, and similarly for the third component. Since the probability of a combination of conditions being fulfilled simultaneously is the product of the respective probabilities of the various conditions being fulfilled separately, it will be seen that (1) is really consequent on (2).

The expression (2) is, however, that found by Gauss for errors of measurement, it is simply the *law of errors*; the two problems are identical and are subject to the law of probability.

This well-known law of Gauss (1777–1855) gives the probability of the occurrence of an error Δ in the observational determination of any quantity.

Probability of error :
$$\frac{K}{\sqrt{\pi}} e^{-K^2 \Delta^2} d\Delta$$

It will be seen that a constant K appears in this expression; it can be shown that this constant is related to the mean error by the simple expression :

$$\frac{1}{K\sqrt{2}} = \text{mean error.}^*$$

The constant κ , which increases as the mean error decreases, is thus a measure of the *degree of precision*. It is clear, too, that this degree of precision should appear in the law of probability of error. It is common experience that an old and worn theodolite gives values of less precision than a new and modern instrument, and that a Mannlicher rifle gives more accurate shooting than an old and out-of-date rifle. The spread of shots is familiar to gunners, and they study the grouping on a target.

It is now possible to advance another step in the application of this law. If it be desired to calculate the number of molecules having velocities lying between the absolute values c and $(c + dc)$ independently of direction, it is necessary to use (1) and to put $u^2 + v^2 + w^2 = c^2$.

Now let the velocity c of one molecule, from among the n molecules situated in a cubic centimetre, be represented by a point of which the co-ordinates are equal to the projections u, v and w of the velocity ; this gives a so-called *point of velocity* ; the product $du \cdot dv \cdot dw$ then represents an element of volume, and (1) shows that the number of molecules per cubic cm. for which the representative point lies within the element of volume $du \cdot dv \cdot dw$ is

$$dn = n \sqrt{\frac{h^3 m^3}{\pi^3}} e^{-hm c^2} du dv dw.$$

Given this result, in order to obtain the number of molecules having velocities between c and $(c + dc)$, it is necessary to sum all the groups dn which lie within the spherical shell bounded by the two spheres of radii c and $(c + dc)$. This sum is found by integrating and we have :

number of molecules whose velocities lie between c and $(c + dc)$

$$dn_c = 4n \sqrt{\frac{h^3 m^3}{\pi^3}} e^{-hm c^2} c^2 dc \dots \dots \dots (3)$$

* It is to be noticed that the mean error is $\sqrt{\frac{\sum \Delta^2}{n}}$, i.e., it is defined as the square root of the mean of the squares of the errors.

Finally, if the product $dn \cdot c^2$ be found for all values of c from zero to infinity, the result may be equated to the product nC^2 , *i.e.*, the total number of molecules multiplied by the mean square of the molecular velocities ; this square as will be shown presently, is of great importance. As a result of this process it is found that

$$C^2 = \frac{1}{n} \int_0^\infty c^2 dn = \frac{3}{2hm} \dots \dots \dots (4)$$

This quantity C must not be confused with the mean of all the instantaneous velocities of the n molecules, *i.e.*,

$$\frac{c_1 + c_2 + c_3 + c_4 + \dots \dots \dots}{n};$$

this latter quantity is called the mean velocity and is obtained by the ordinary process of finding the arithmetic mean, *i.e.*, by multiplying each velocity c by the number of molecules which have that velocity, as found from (3), and then dividing the sum of the products by n ; in this way is found that :

$$\text{the mean velocity } v = \frac{1}{n} \int_0^\infty c \, dn = \frac{2}{\sqrt{\pi hm}} \dots \dots \dots (5)$$

The fact that these two quantities v and C are not the same can easily be seen by considering the case of several numbers, *e.g.*, 2, 4, 0, 1, 2, 5, 0, the arithmetic mean of which, 2, is not the same as

the value of the expression $\sqrt{\frac{2^2 + 4^2 + 0^2 + 1^2 + 2^2 + 5^2 + 0^2}{7}}$.

In the case of the molecular velocities, the two quantities—one the mean properly so called, v , and the other, C , defined as the square root of the mean of the squares—are connected by the relation

$$\frac{v}{c} = \sqrt{\frac{8}{3\pi}} \cong \frac{12}{13}$$

At this point it is desirable to make a remark ; the reader will not have failed to notice that in Maxwell's expression (2) and in those which have been derived from it so far, the product hm always appears, and, in fact, takes the place of the constant K^2 in Gauss's law ; but why is not this product hm replaced by a single

symbol, and why is the mass of the molecule retained? The answer will be clear when it has been shown that h is equal for all gases and that it is connected with the temperature by the simple relationship of inverse proportionality.

Calculation of the Velocity C in Terms of the Pressure and Density of the Gas

Let it be assumed that the pressure exerted by a gas is the result of the incessant impacts of the molecules on the walls of the vessel; in order to determine the pressure it is only necessary to calculate the steady force experienced by each unit area of a rigid wall uniformly bombarded by a shower of projectiles which move in parallel paths with equal velocities and which are reflected from this wall without loss or gain of energy.

The molecules of mass m , and moving with a velocity u perpendicular to the walls, are elastic, so that the direction of their motion is reversed after the impact; the effect, therefore, is double what it would be if they were inelastic.

Bearing this in mind, and remembering that $F.t = m.u$ (the impulse of a force F acting for a time t is equal to the change of momentum mu) let us consider a cube of one centimetre-side (in order to fix our ideas). This cube contains molecules having velocities u along the X-axis: a molecule of mass m strikes that

side of the cube which is normal to the X-axis at the rate of $\frac{u}{2}$

impacts per second, and so loses momentum equal to $2 mu \times \frac{u}{2}$;

for all the n molecules contained in the cube the total momentum lost is therefore $nm u^2$.

But this momentum is the gas pressure p . Thus

$$p = nm u^2 = \frac{1}{3} nm C^2 \quad . \quad . \quad . \quad . \quad . \quad (6)$$

We may write $\frac{1}{3} C^2$ instead of u^2 , as in the above equation, since in

an actual gas the molecules have different component velocities,

and in summing the u^2 terms it is necessary to introduce the mean square of the u components, which is clearly equal to one-third of C^2 .

Finally, if nm be the density, *i.e.*, the mass of unit volume, then :

$$\text{pressure } p = \frac{1}{3} nm C^2 = \frac{1}{3} C^2 d \quad . \quad . \quad . \quad (6A)$$

where d is the absolute density.

This equation is very important. It shows that if the pressure of a gas and its density be known, it is at once possible to obtain the mean square of the molecular velocities, *i.e.*, all that is necessary in order to solve to a first approximation every problem in the kinetic theory.

It is to be noticed that the foregoing proof is completely independent of the particular form of the law of distribution of velocities.

Gas Laws for a Perfect Gas.—The Absolute Temperature is proportional to the Molecular Energy

A perfect gas is one which is infinitely expanded so that the molecules do not exert any appreciable influence on one another except at the instant of collision.

It is well known that from the laws of Boyle and of Gay-Lussac the following equation of the gaseous state can be deduced :

$$pV = RT \quad . \quad . \quad . \quad . \quad . \quad (7)$$

T is the absolute temperature, the zero of which is at -273°C . ; p and V are respectively the pressure and the volume occupied by a given mass of gas. Equation (7) expresses the facts that when the temperature is constant the volume of the gas is inversely proportional to the pressure, and that the volume is proportional to the absolute temperature. R is a constant, and it is to be noticed that if for each gas the quantity considered is proportional to the molecular weight, R is the same in every case, since for every gas such a quantity, containing an equal number of molecules, has the same volume if measured at the same temperature and pressure ; this is an inverse application of Avogadro's hypothesis. Thus R is a universal constant, and on the C.G.S. system is equal

Mixtures of Gases. Equipartition of Energy

We have seen that any two gramme-molecules in the gaseous state, when at the same temperature, have the same amount of molecular energy of translation, viz., $\frac{3}{2} RT$. Now on Avogadro's hypothesis, these two masses both contain the same number of molecules; the molecules of the various gases have, therefore, the same mean energy of translation at the same temperature:

$$\frac{3}{2} \frac{R}{N} T = \frac{mC^2}{2}.$$

The constant $\frac{R}{N}$ is called *Boltzmann's constant*, and has the value 13.7×10^{-17} . In what follows it will be indicated by k .

If equal volumes V of two gases at the temperature T be mixed, and if the mixture occupy the volume $2V$ the kinetic energies are added, the pressure remains unchanged, each gas exerting that pressure which it would exert if it were alone, and the temperature is also unaltered.

We may then conclude that in any gaseous mixture the various kinds of molecules possess the same mean kinetic energy; the small molecules move more rapidly than the heavy ones as, indeed, appears self-evident.

This result is a particular case of the well-known *principle of equipartition of kinetic energy* to which we shall return.

We know that solutions—which are in every respect similar to gases—obey the same laws; the molecule, whether it be heavy or light, has a mean kinetic energy equal to $\frac{3}{2} \frac{R}{N} T$. We shall see later that the validity of the principle has been verified also for large particles in suspension in colloidal emulsions.

The meaning of the Constant h in Maxwell's Law

We will now return to the results deduced from our consideration of Maxwell's law of the distribution of velocities (see p. 55).

It has been found that the number dn_1 of molecules which, out of the n contained in a cubic centimetre, have a component

velocity (measured along a given axis) lying between u and $(u + du)$ is

$$dn_1 = n \sqrt{\frac{hm}{\pi}} e^{-hmu^2} du$$

and it has been shown that the mean square of all the velocities is $C^2 = \frac{3}{2hm}$.

Thus the mean kinetic energy of a molecule is $\frac{mC^2}{2} = \frac{3}{2} \frac{RT}{N}$, where N is the number of molecules in a gramme-molecule and is known to be the same for all gases.

Thus it follows at once that $\frac{1}{2h} = \frac{R}{N} T$. This result is of great interest since it shows that for gases the constant h has always the same value. It is, therefore, a *universal* constant. The temperature of a gas may thus be defined on the basis of the kinetic theory by the following formula :

$$\frac{mC^2}{2} = \alpha T = \frac{3}{4h}$$

α being the same for all gases.

Number of Molecules per second striking one Square Centimetre of the Walls

Since Maxwell's law of distribution of velocities is independent of the orientation of the axes of reference, the axis of X may be taken in the direction of the normal to the walls at a point. In an elementary cube 1 cm. high and having one square centimetre of the wall as base, the number of molecules which have velocities lying between u and $(u + du)$ is dn_1 and the number of impacts due to them is udn_1 ; the total number of impacts is therefore

$$\int_0^{\infty} udn_1$$

Integrating, it is found that :

The number of molecules striking one square centimetre of the walls per second is

$$\int_0^{\infty} u dn_1 = \frac{n}{2\sqrt{\pi hm}} = \frac{nC}{\sqrt{6\pi}} = \frac{nv}{4}.$$

An application of this important result will follow shortly.

Flow from Small Orifices

The values of the molecular velocities as given by the kinetic theory had not been verified by direct measurement until a few years ago, but the phenomenon of the flow from small orifices, which will now be considered, has lately afforded a valuable confirmation of the theory.

The flow of a gas is imagined to take place into a vacuum through a small aperture produced by the sudden removal of an element of the wall; it is assumed that the molecules which originally struck this part of the wall now disappear through the hole; the amount of the flow is equal to the product of the mean velocity and the density.

The velocity assumed must, it is clear, be the component velocity perpendicular to the opening; this component is governed by Maxwell's law of distribution, and out of every n molecules the number dn having a velocity, perpendicular to the hole, lying between the limits u and $(u + du)$ is

$$dn = n\sqrt{\frac{hm}{\pi}} e^{-hmu^2} du. \checkmark$$

To find the mean velocity this expression is integrated between the limits zero and infinity, and it is found that the mass passing out is the same as it would be if all the molecules issued with a velocity $\frac{1}{4}v$; this is proportional to C , since C and the mean velocity v are connected by means of the simple relationship already given:

$$v = C\sqrt{\frac{8}{3\pi}}$$

Since, then, the mean momentum of a molecule, $\frac{mC^2}{2}$, is proportional to the absolute temperature and is the same for all

gases at the same temperature, there follows the important result that for different gases at the same temperature the velocities of outflow are inversely proportional to the square roots of the molecular weights.

This law was strikingly confirmed by Graham's experiments published in 1846, in which various gases flowed through a brass sheet pierced with a hole.

Hydrogen, which is sixteen times as light as oxygen, passes through such a hole four times as fast as the latter gas.

It is clear that once this law has been established it can be used to determine unknown molecular weights by comparison with a gas of known molecular weight.

The Breadth of Spectral Lines

We have seen how the flow of a gas through small apertures gives the ratio between the molecular velocities, and hence enables the results of the kinetic theory to be verified with certainty.

A further valuable verification is provided by a phenomenon—that of the broadening of spectral lines—which gives the molecular velocity by a method independent of any knowledge of the pressure, and this, moreover, in absolute value and not simply in relative measure.

It is well known that the electric spark causes a rarefied gas to glow; when examined by means of the spectroscope the light emitted from Geissler tubes is resolved into fine lines each corresponding with a homogeneous light; thus, for example, such a term as “the helium line” of wave-length 5876 Ångström units is used.

If now a suitable spectroscope (an interferometer) be used, it is always found that these lines have a certain breadth, showing that they do not correspond to strictly monochromatic light. This is what Lord Rayleigh predicted as a result of applying the well-known principle due to Doppler.

The proof of this prediction is not possible in the laboratory because no velocities are available which are not negligible in comparison with the velocity of light; Doppler's effect depends

on the ratio $\frac{v}{c}$, *i.e.*, the ratio of the velocity of the light source to that of light itself. This fraction is not, however, negligible for an atom which vibrates in the line of sight with a velocity of the order of 200 metres per second ; it is true that the atoms do not vibrate only in the direction of the line of sight, but in all possible directions ; those which move in a direction normal to the line of sight do not give a Doppler effect ; the others give rise to a broadening of the spectral lines if the spectroscope has a sufficiently high resolving power.

The maximum change of frequency is $\frac{\nu_1 - \nu_2}{\nu_0}$, where ν_2 is the altered frequency, ν_1 the original frequency, and ν_0 the mean frequency ; the semi-breadth of the spectral line is, on the scale of wave-lengths :

$$\frac{\epsilon}{\lambda_0} = \frac{v}{c} \quad c = \text{velocity of light,}$$

λ_0 being the wave-length of the original monochromatic light.

For example, if $\frac{v}{c}$ be $\frac{1}{100,000}$, the wave-length is both increased and decreased by $\frac{1}{100,000}$ of its value. We shall now see how

these considerations may be made use of for determining an atomic weight by the examination of interference fringes.

It is well known that one musical sound superposed on another may produce silence at any point where the two differ in phase by half a wave-length ; similarly, light added to light may produce darkness by interference.

When the light used is strictly monochromatic, an interferometer will give interference fringes when the difference of path for the two rays is half a wave-length or a multiple of this and, as is well known, these fringes will be quite sharp whatever the *difference of path*, whether it be 100,000 half wave-lengths or 200,000.

Fringes are obtained because at the various points on a given plane there are superposed rays which differ in phase by a wave-length (producing light), or by half a wave-length (producing

darkness), or by a fraction of a wave-length (producing light of modified intensity), and, as these conditions follow one another in regular order, the result is a succession of alternately dark and light fringes.

Examination of a spectral line from a Geissler tube—particularly that emitted from the luminous capillary portion—would show that the light was strictly monochromatic were it not for the random vibrations which it undergoes ; actually, however, with a spectroscop of sufficient resolving power a line is found to have a certain finite breadth. Hence, with an interferometer, the visibility of the interference fringes will depend on the length of path of the interfering rays because of the superposition of the effects due to *different parts* of the spectral line employed. If the difference of path be sufficiently great it is found that the lines finally become confused and cease to be visible.

A numerical example will show better what is meant. If the mean velocity of the vibrating atoms be $\frac{1}{100,000}$ of the velocity of

light, the line has a breadth of $\frac{2}{100,000}$ as already stated. If two

rays, the homogeneity of which does not exceed this amount, interfere in a given plane, the definition of the interference fringes given by the apparatus is reduced as the path difference of the two interfering rays is increased. Although the definition may still be good at 10,000 or at 20,000 wave-lengths, when the difference of path reaches 50,000 wave-lengths the fringes cease to be visible, since, although the *central* radiations are in opposite phases at a given point in the plane, and would give a dark line in the interference pattern, the *side* radiations are in the same phase at this point. In general, therefore, the limit of visibility is reached at a

path difference $p = \frac{c}{2v}$, and from that point onwards the fringes cease to appear and the field of view has a uniform brightness.

This gives the relation between the breadth of the spectral line, the limit of visibility of the fringes and the mean velocity of the vibrating molecule. Since this velocity can be expressed in terms

of the temperature, it is only necessary now to note that the *mean*

$$\text{velocity} = \sqrt{\frac{8RT}{\pi M}}, *$$

where M = mass of the gram-molecule

R = the gas constant

T = absolute temperature.

Thus the *limiting order of interference* $p = \frac{c}{2v} = (1.03 \times 10^6) \sqrt{\frac{M}{T}}$,

and since, as was explained above, $\frac{\epsilon}{\lambda_0} = \frac{v}{c}$,

it follows that

$$\frac{\epsilon}{\lambda_0} = (4.85 \times 10^{-7}) \sqrt{\frac{T}{M}},$$

where ϵ is the half-width of the spectral line.

We have so far followed an inexact line of reasoning in that we have assumed that the velocities of the vibrating particles are all equal; actually these velocities are distributed according to Maxwell's law; the breadth of the spectral line produced—and hence the limiting order of interference visible—is affected by this; a more rigid analysis of the phenomenon leads to a slight correction, viz., to the equation

$$p = (1.22 \times 10^6) \sqrt{\frac{M}{T}}.$$

Accurate experiments were made with the monatomic rare gases of the atmosphere (helium, neon and krypton) using Geissler tubes immersed in a bath of liquid so that the temperature T might be known accurately, and then immersed in liquid air; it was found (Fabry and Buisson) that

Atomic Weight.	Wave-length (Ångström).	Ordinary temperature.		In liquid air.
		p-observed.	p-calculated.	p-observed.
Helium 4 .	5,876	144,000	144,000	241,000
Neon 20 .	5,852	324,000	321,000	515,000
Krypton 83 .	5,570	600,000	597,000	950,000

* For $\frac{v}{C} = \sqrt{\frac{8}{3\pi}}$ and $\frac{1}{2}MC^2 = RT$.

The agreement between the values predicted on the theory and those found for p by experiment is perfect.

It is to be noted in passing that for a Geissler tube immersed in liquid air, the line due to krypton gives interference fringes which are still visible when the path difference is of the order of a million wave-lengths, *i.e.*, up to 53 cm.

The law connecting the limit of interference with the absolute temperature is also verified, for it is evident that p varies inversely as \sqrt{T} ; actually it is found that on going from room temperature ($T = 290$) to the temperature of liquid air ($T = 92$) the limit of visibility is increased approximately in the ratio 1.70.

The effect of cooling on the breadth of the spectral lines is very striking; when, with the tube at normal temperature, the limit of interference has been reached, the fringes reappear brilliantly when the tube is immersed in liquid air.

The atomic weight of the luminous particles—if this is unknown—may be obtained from a knowledge of the breadth of the spectral lines; in the case of a gas of which the molecules are monatomic (mercury, cadmium, helium, neon, krypton), the weight of the particles is, as in the case of the examples above, equal to the atomic weight.

In the case of monatomic gases this result is not unexpected, but it is found that for gases with two atoms to the molecule, and for compounds as well, the mass of the luminous particles is not that of the molecule, but that of the atom.

In conclusion, it may be said, then, that the study of the breadth of spectral lines provides a beautiful confirmation of the kinetic theory of gases. It is a marvellous thing to realise that the breadth of a spectral line enables us to determine both the velocity of a star relative to our world and equally the atomic weight of the atom from which the spectral line is emitted.

Buisson, Fabry and Bourget have used the expression

$$p = (1.22 \times 10^6) \sqrt{\frac{M}{T}}$$

to estimate the temperature of the nebulae

from observations of the interference obtained from a spectral line; this method would give for the nebula in Orion, using the

hydrogen line H, a temperature of about 15,000°; actually this is an upper limit, for there are other causes which may give rise to a broadening of the spectral lines.

The Direct Verification of the Molecular Velocities

We have so far had two proofs of the kinetic theory, both of them indirect proofs, but Professor Otto Stern at Frankfort in 1920 * succeeded in obtaining a *direct* verification of molecular velocities by means of his atomic rays.

We will give a brief description of his work; further details will be found in the *Zeitschrift für Physik (loc. cit.)*,* where the author has himself described the experiments.

In a very highly evacuated vessel he places a small quantity of silver which is brought to a high temperature (over 1,000° to vapourise it; the melting-point of silver is 961°).

As the vacuum in the vessel is a very high one, the atoms can travel freely without colliding, and if they escape from a very small aperture it can be assumed that they emerge with the velocity which gas molecules of the same mass would have at that temperature. These atomic rays were first thought of by Duoyer in 1911.

The kinetic theory shows that the mean square of the velocity of emergence, C^2 , is given by the equation

$$\frac{1}{2} MC^2 = \frac{3}{2} N T,$$

from which it follows that

$$C = \sqrt{\frac{3 RT}{NM}} = 157.9 \sqrt{\frac{T}{M}}$$

in metres per second.

Imagine, now, a fine pencil of such atomic rays, limited by suitable openings situated practically on the axis of a rotating cylinder of radius l , and let ν be the frequency of rotation of the cylinder, which is evacuated; the atomic rays which originally struck the surface of the cylinder along a certain generating line

* See *Zeits. für Physik*, 2, p. 40, 1920; 3, p. 417, 1920.

will now trace out another line parallel to this generating line but displaced from it by a distance s , since during the time that they are travelling towards the wall after they have emerged from the slit the cylinder rotates ; the angle $2\pi\nu\tau$ is described in the time τ during which the atoms traverse the distance $\frac{l}{c}$, so that we have :

$$s = 2\pi\nu l \times \tau = 2\pi\nu l \times \frac{l}{c} = 2\pi\nu \frac{l^2}{c}$$

The values of l , ν , and s are known ; s is found by measuring the displacement of the streak formed by the deposit of silver, and hence C may be calculated. As an example, if l is 10 cm. and the velocity C is 500 metres per second, when the cylinder rotates at about 50 revolutions per second, the displacement is 6 mm. This is not too small a quantity.

At a temperature of $1,200^\circ$, the theory gives a value of 584 metres per second for the velocity of the atoms, and Stern obtained about 590.

We have given only a general idea of the method and the apparatus, which are, in reality, much more complicated. Actually the velocities of emergence of the atoms are not all the same but vary over a wide range, so that the silver deposit obtained is not a line but a band or *streak* ; thus the calculations are based on the *most probable velocity*, which is the velocity corresponding to the *maximum density of the deposit* ; it may be shown by calculation

that this most probable velocity is $C \sqrt{\frac{2}{3}}$, so that the position of maximum density of the deposit is found, and the velocity calculated from this must be divided by $\sqrt{\frac{2}{3}}$ in order to obtain C ;

actually, Stern found a velocity of 475 metres per second, giving 590 for C .

Born, too, has determined the free path of the atoms by an ingenious method based on the study of the deposit formed by these atomic rays at various distances from their origin.

Gases under Actual Conditions.—Van der Waals' Equation (1880)

Gases do not rigorously obey Boyle's and Gay-Lussac's law except when they are infinitely rarefied; just as the molecules of a salt are not completely dissociated except in an infinitely dilute solution (so that the theoretical osmotic pressure is slightly different from that found in practice), so in the case of a gas, if it is considerably compressed, it no longer behaves as if the distances between the molecules were large compared with their molecular dimensions. Not only does the occupied volume, *i.e.*, the volume occupied by impenetrable matter, become noticeable, but also it must be concluded from the liquid and the gaseous states, that the cohesive forces—weaker in the gas than in the liquid—may now have an appreciable effect. These two considerations give rise to a two-fold correction to the gas equation so as to make it conform to the conditions of an "imperfect" gas, *i.e.*, an actual gas.

We shall confine ourselves to giving a condensed outline of the well-known equation of Van der Waals, who was professor at the University of Amsterdam,* and who for much other work, besides that leading to the equation which bears his name, is reckoned among the great contemporary physicists.

It is considered that the molecules cannot actually touch and that they behave as if contact took place between spheres associated with them. If, then, there be conceived to exist around each molecule a *sphere of action* having a *radius* equal to the *molecular diameter*, the total volume of these spheres must be subtracted from the total volume of the gas in order to obtain the effective volume of the actual empty space.

When stating that the pressure varies inversely as the volume, therefore, it is necessary to adopt, not the total apparent volume,

but this volume diminished by $\frac{4}{3} \pi \sigma^3$, where σ is the *molecular diameter*.

In the same way, if it be desired to compress into a smaller

* Died 1925.

space a very dispersed crowd of people, this is achieved by reducing the distance between the individuals and not by compressing their bodies. The volume to be used in the equation $pV = RT$ must therefore be $V - \frac{4}{3}\pi\sigma^3N$, since there are N molecules in one gramme-molecule (N is called Avogadro's number). However, if

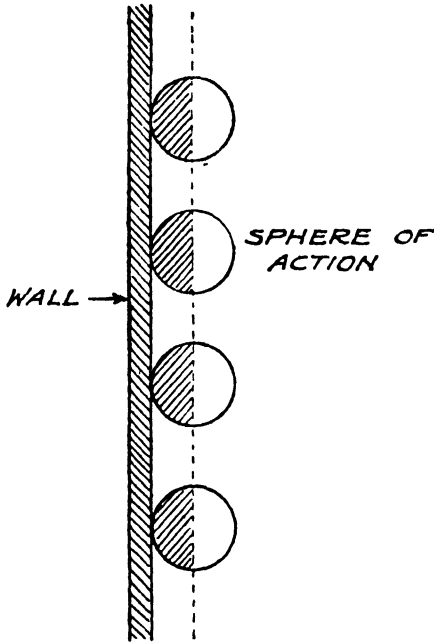

FIG. 14.

we consider that, in producing the effect of pressure, the molecules *touch* the wall of the containing vessel when the centres of their spheres of action are separated from the wall by a distance equal to the radius of these spheres, we find that a further correction is necessary.

Actually we think of all the spheres of action as having a radius equal to the molecular diameter; thus the gas becomes reduced to N spheres, and these imaginary spheres, when they approach the wall of the vessel, do not touch it, since their centres are at a distance from it equal to σ ; this evidently gives the gas an additional volume

equal to the volume of the hemispheres shown shaded in Fig. 14. This volume is $\frac{2}{3}\pi\sigma^3N$ per gramme-molecule. Taking into account both the corrections just described, and noting that they operate in different directions, it will be seen that the volume to be inserted in the fundamental equation $pV = RT$ is equal to

$$V - \frac{2}{3}\pi\sigma^3N.$$

It is to be noted that the quantity $\frac{2}{3} \pi \sigma^3 N$ is equal to four times the total volume of the molecules, since σ , which has been taken as the radius of the sphere of action, is equal to the molecular diameter.

It now remains to consider the effect of cohesion. The molecules of a fluid attract one another, and in the neighbourhood of the walls this attraction is not symmetrical but is directed towards the interior of the gaseous mass, being additional to the effect of the walls.

This effect, taken over a square centimetre of the walls, is jointly proportional to the density of the molecules which are attracted and of those which attract, *i.e.*, it may be expressed by a term in n^2 , or in other words, a term $\frac{a}{V^2}$ where a is a constant.

Taking account of these effects and of the corresponding corrections they involve, the gas equation becomes finally :

$$\left(p + \frac{a}{V^2}\right) (V - b) = RT \quad \dots \text{VAN DER WAALS' EQUATION,}$$

where $b = \frac{2}{3} \pi \sigma^3 N$.

This is the celebrated equation of Van der Waals which has been well confirmed by experiment. For a given mass of gas, from a knowledge of two sets of corresponding values of p , V and T , it is possible to obtain at once the two constants a and b ; naturally if a number of sets of corresponding values of p , V and T are known, it is possible to obtain, by the method of least squares, the best values to adopt for a and b .

The values of the constants a and b are obviously very small; for example, in the case of carbon dioxide, Van der Waals adopted the values

$$a = 0.00718 \quad b = 0.00190.$$

The reader will shortly see some important applications of these conceptions which we owe to Van der Waals.

Other similar formulæ proposed by various authors will not be mentioned.

***Discussion of Van der Waals' Equation**

As is well known, the curve obtained by plotting values of volume as abscissae and the corresponding values of pressure (*at a given temperature*) as ordinates is called an isothermal.

The equation to an isothermal is obtained by putting T constant in the equation

$$\left(p + \frac{a}{v^2}\right)(v - b) = RT.$$

In order to find the point at which an isothermal shows a maximum or a minimum it is only necessary to find the expression for $\frac{dp}{dv}$ and equate this to zero. This gives

$$\frac{dp}{dv} = -\frac{RT}{(v - b)^2} + \frac{2a}{v^3} = 0,$$

from which we have

$$T = \frac{2a(v - b)^2}{Rv^3} \dots \dots \dots (1)$$

The equation (1) gives, for any isothermal, the value of the volume corresponding to a maximum or a minimum pressure. If now we wish to find what is the maximum temperature for the conditions represented by this equation, we obtain the expression for $\frac{dT}{dv}$ from (1) and equate the result to zero. This discussion is very important, since obviously the value of T thus obtained is the critical temperature of the gas, and the corresponding volume is the critical volume v_c .

$$\frac{dT}{dv} = \frac{6aRv^2(v - b)^2 + 2aRv^3(2v - 2b)}{3Rv^4} = 0,$$

or, simplifying,

$$(v_c - 3b)(v_c - b) = 0.$$

Taking $v_c = 3b$ and inserting in (1)

$$\text{Critical temperature} = T_c = \frac{2a(v_c - b)^2}{Rv_c^3} = \frac{8a}{27Rb}$$

It can be shown that these two values v_c and T_c are really the critical values. Actually the critical point is defined mathematically by the condition that the isothermal is there sensibly horizontal, *i.e.*, that $\frac{dp}{dv} = 0$ and $\frac{d^2p}{dv^2} = 0$, so that from Van der Waals' equation

$$\text{viz., } p = \frac{RT}{v - b} - \frac{a}{v^2} \quad \text{we have } \frac{dp}{dv} = \frac{RT}{(v - b)^2} + \frac{2a}{v^3} = 0$$

$$\text{and } \frac{d^2p}{dv^2} = \frac{2RT}{(v - b)^3} - \frac{6a}{v^4} = 0$$

It can be shown at once that the bend in the curve referred to actually takes place at the point where

$$T_c = \frac{8a}{27Rb} \quad v_c = 3b, \text{ and hence } p_c = \frac{a}{27b^2}$$

as found previously.

Finally, if Van der Waals' theory were rigorously true, it would be possible, from experimental observations of the critical point, to deduce the constants

a and b , and the values of these quantities would enable the isothermal curves to be obtained.

It is not, however, absolutely exact, a and b are not really constants which are independent of the values of temperature and pressure, and this is to be expected when it is remembered that the molecules are not rigid elastic spheres, but complete systems of atoms. Moreover, even the monatomic molecules are formed, as we shall see, of electric particles, so that in the so-called collisions the repulsive forces which come into play are those manifested between charges when the electric fields surrounding them are brought within the

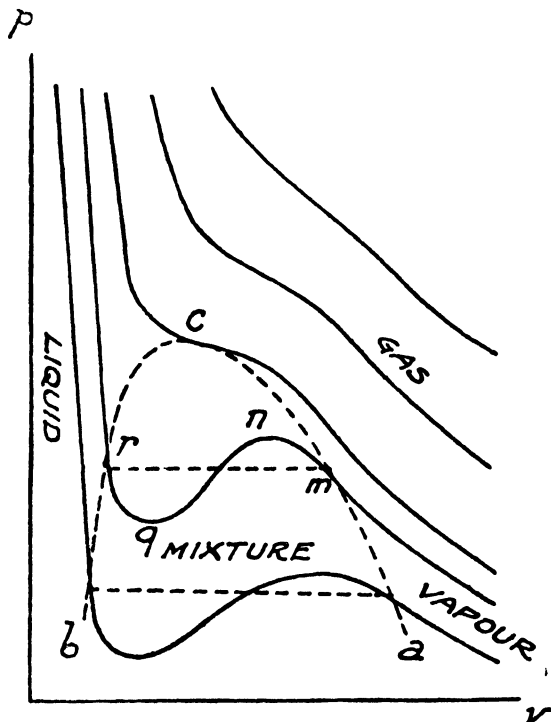

FIG. 15.

range of their mutual action; the higher the velocities of the molecules the more intimate will be the inter-action during the collision.

Fig. 15 shows the form of the isothermals (constant-temperature curves) in the neighbourhood of the critical point C . The liquid line is bC , for this is the locus of all the points at which a slight reduction of volume causes the mass to become liquid. The saturated-vapour line is aC .

It is only within the region aCb that liquid and vapour can exist together in equilibrium. The portion of the isothermal which lies between m and n represents a condition of supersaturation, and that between n and q a condition of instability; the isothermals really follow the horizontal lines from m to r , because as the volume diminishes the pressure is not increased. The gas is, however, practically perfect in the regions where the pressures are low and the volume correspondingly large.

*Van der Waals' Equation and the Joule-Thomson Effect

We may recall here the nature of the Thomson effect and how it gives, for any gas, the values of the two constants a and b of Van der Waals' equation.

If a gas expands by an amount equal to Δv against the external pressure p , it does work equal to $\Delta v \cdot p$. and this is supplied from the molecular kinetic energy; the equation for the ideal gas ($pv = RT$) implies that it is not the energy due to the mutual forces between the molecules which is converted into external work when these molecules are brought closer together or allowed to separate more widely.

We have seen, however, that the derivation of Van der Waals' equation introduces the idea that the volume of the molecules themselves cannot be neglected in comparison with the total volume when the pressure of the gas is under consideration.

The following conclusions may, then, be drawn immediately: if a perfect gas expands into a larger space where the pressure is zero, the total work performed is zero, and therefore the gas is not lowered in temperature;

but in an actual gas matters are different. Expansion, even into a vacuum, will then be accompanied by a change of temperature; it is easy to see what the direction of this change will be, for it is clear that, if the molecules of the expanding gas attract each other, the change which takes place on expansion from a vessel A into a vacuum B (so as to occupy a total volume $A + B$) will be a reduction of the temperature. This is Gay-Lussac's well-known experiment, the arrangement of which is shown in Fig. 16.

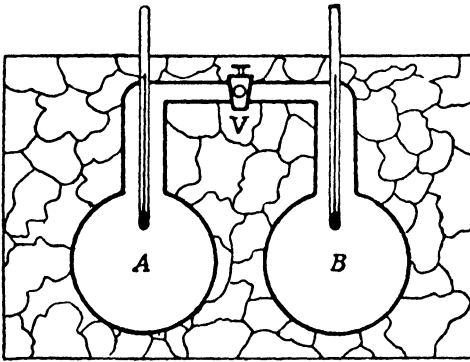

FIG. 16.

Two carefully heat-insulated vessels were connected by a stopcock V . A was filled with compressed air while B was evacuated. A thermometer was placed in each vessel. When the whole system had reached the temperature of the surroundings, the tap V was opened and air flowed from A to B . The air in A was cooled because it had to do work in expanding against the pressure of the air which had entered B ; in so doing it compressed the air in B , with the result that this was heated, and so there was neither loss nor gain in the system $A + B$ regarded as a whole. Thus, *if no work is done against the molecular attractions*, there should be no change of temperature in the system $A + B$ as a result of the expansion.

Owing to lack of precision in the measurements, the high thermal capacity of the thermometers employed, and the smallness of the effect, Gay-Lussac could not detect any change, and neither could Joule, who repeated the experiment with a different arrangement of apparatus.

However, the problem was again attacked, and this time successfully, by Joule and W. Thomson (Lord Kelvin).

Without going into the details of the experimental procedure, we shall calculate approximately the magnitude of the change of temperature ΔT .

Let us consider a unit mass of gas having initial energy equal to u_1 and final energy u_2 . Then $Q = u_2 - u_1 + p_2v_2 - p_1v_1$ will be the change of energy.

It is clear, too, that

$$u_2 - u_1 = \int_{v_1}^{v_2} (a/v^2) dv = -a \left(\frac{1}{v_2} - \frac{1}{v_1} \right).$$

Applying Van der Waals' equation to the original and final volumes :—

$$\left(p_1 + \frac{a}{v_1^2} \right) (v_1 - b) = RT_1$$

$$\left(p_2 + \frac{a}{v_2^2} \right) (v_2 - b) = RT_2$$

it is easily found that

$$p_2 v_2 - p_1 v_1 = - \left(\frac{a}{v_2} - \frac{a}{v_1} \right) + b(p_2 - p_1) + a \cdot b \left(\frac{1}{v_2^2} - \frac{1}{v_1^2} \right) + R(T_2 - T_1).$$

Now ab is a small quantity of the second order and may be neglected, so that

$$Q = u_2 - u_1 + p_2 v_2 - p_1 v_1 = -2a \left(\frac{1}{v_2} - \frac{1}{v_1} \right) + b(p_2 - p_1) - R(T_1 - T_2).$$

Remembering that, very nearly, $v_2 = RT_2/p_2$ and $v_1 = RT_1/p_1$, the quantity $\frac{1}{v_2} - \frac{1}{v_1}$ may be written approximately as follows :—

$$\frac{p_2}{RT_2} - \frac{p_1}{RT_1} = \frac{1}{R} \left(\frac{T_1 p_2 - T_2 p_1}{T_1 T_2} \right) \simeq \frac{1}{R} \cdot \frac{p_2 - p_1}{T}$$

The second stage of the simplification results from the fact that T_1 and T_2 only differ by a very small amount.

We have then

$$\begin{aligned} Q &= - \frac{2a}{RT} (p_2 - p_1) + b(p_2 - p_1) - R(T_1 - T_2) \\ &= \left(\frac{2a}{RT} - b \right) (p_1 - p_2) - R(T_1 - T_2) \dots \dots \dots (1) \end{aligned}$$

But we know that *

$$C_p - C_v = R/J \dots \dots \dots (2)$$

and for unit mass

$$Q = JC_v (T_1 - T_2) \dots \dots \dots (3)$$

whence, combining equations (1), (2) and (3)

$$JC_p (T_1 - T_2) = \left(\frac{2a}{RT} - b \right) (p_1 - p_2)$$

and, finally,

$$\frac{\Delta T}{\Delta p} = \frac{T_1 - T_2}{p_1 - p_2} = \frac{1}{JC_p} \left(\frac{2a}{RT} - b \right) \dots \dots \dots (4)$$

This result is, naturally, only approximate on account of the simplifying approximations which have been made in the steps leading up to it.

Equation (4) states that the difference of temperature which is caused when a gas expands from pressure p_1 to pressure p_2 is directly proportional to the change of pressure. Further, the difference ΔT is greater the smaller the value of C_p , as would naturally be expected.

* C_p = specific heat of the gas at constant pressure.
 C_v = specific heat at constant volume.
 J = mechanical equivalent of heat.

If $\frac{2a}{RT}$ is greater than b the gas is cooled when it expands, while if, on the other hand, $\frac{2a}{RT} < b$ the temperature rises; thus the effect has a point of inversion.

The particular temperature at which the inversion takes place can be at once obtained from the equation $2a/RT = b$, which gives

$$T_{inv.} = 2a/Rb \dots \dots \dots (5)$$

This shows how the constants of the Van der Waals' equation are linked up with the Thomson effect.

In making use of this formula it is necessary to pay careful attention to the units employed. The constant a is expressed in $cm.^6 \times atmospheres$, while b is expressed in $cm.$; this clearly follows from the form of the equation, viz. $(p + a/v^2)(V - b) = RT$.

Specific heats, however, are generally given per gramme of gas. Equation (4), when transformed to these practical units, becomes

$$\frac{\Delta T}{\Delta p} = \frac{0.0242}{\rho C_p} \left(\frac{2a}{T/273} - b \right) \dots \dots \dots (4A)$$

where ρ is the density.

For carbon dioxide at 0° Centigrade

- $a = 0.00874.$
- $b = 0.0023.$
- $C_p = 0.000399.$

This gives $\frac{\Delta T}{\Delta p} = 0.925$, and Joule actually found a cooling effect equal to one degree per atmosphere.

For hydrogen the inversion temperature calculated from the formula $T_{inv.} = 2a/Rb$ is found to be about 200° absolute. Olszewski found experimentally that the inversion temperature was 193°, i.e., that above this point hydrogen was heated when it expanded, while below this temperature it was cooled on expansion.

The cooling due to the Joule-Thomson effect is used in Linde's commercial method for producing liquid gases.

The Mean Free Path of the Molecules

The distance traversed by a molecule between two successive collisions is very variable, but it is obvious that for a gas in a steady state the mean free path plays an important part in many phenomena; for example, a gas conducts heat better the greater this mean free path becomes.

If a horizontal disc suspended by a thread be imagined to rotate rapidly, it will, in its movement, drag with it the neighbouring layers of gas owing to the frictional effect, and this dragging will be the more marked (i.e., more distant layers of gas will be affected) as the mean free path of the molecules becomes greater.

The calculation of this quantity is quite easy; remembering

that n is the number of molecules in a cubic centimetre and σ the radius of the sphere of action, each molecule in its movement sweeps out a volume equal to $\pi\sigma^2 \times v$ per second. This volume bears to the total volume, *i.e.*, unity, the same ratio as the number i of collisions bears to the total number of molecules, n . Hence

$$\pi\sigma^2v = i/n.$$

Thus the mean free path is simply the ratio of the distance traversed in unit time to the number of collisions made in that time, *i.e.*,

$$l = v/i = 1/\pi n\sigma^2.$$

Actually the molecule is not a free body moving hither and thither among other molecules which are at rest, but all the molecules are in motion with a mean velocity v , and this reduces the mean path; actually, if two molecules collide with absolute velocities equal to u_1 and u_2 , the angle between these velocities being ϕ , the relative velocity is given by the third side of the triangle of velocities and the square of this side equals $u_1^2 + u_2^2 - 2u_1u_2\cos\phi$.

Since, *on the average*, $\cos\phi$ may have either sign, the relative velocity U is found on the average to be given by $\sqrt{2U_{\text{mean}}^2} = v\sqrt{2}$, and not simply by v .

It follows that the mean free path which it was desired to evaluate is given by :

$$\text{mean free path } l = \frac{1}{n\pi\sigma^2\sqrt{2}} \dots \dots \dots (1)$$

Remembering that n is the number of molecules in a cubic centimetre while N is the number in the volume V occupied by one gramme-molecule, so that $V = N/n$, it follows that

$$l = \frac{V}{\pi\sqrt{2} \cdot \sigma^2 N}$$

where $V = \text{volume of the gramme-molecule}$.

This expression would give a value of l if Avogadro's number N were known, or *vice versa*. Now one of the fundamental objects of the atomic theory is to discover the number of molecules contained in one gramme-molecule of every substance, and we

are at length well on the way to determining this important constant, viz., Avogadro's number, for if it is possible to find one other relation involving the mean free path, both N and the free path itself may be determined; this is what we shall now proceed to consider.

The Law of Distribution of Free Paths

It is evident that the actual free paths of a molecule are all different from the mean free path and the question may be asked how these actual free paths are distributed about the mean.

The law of distribution may be derived as follows :—

In the molecular random arrangement, the probability that no collision will occur over the path $x + dx$ is made up of two independent probabilities, *i.e.*, (i.) of the probability $f(x)$ that a collision will not occur along the path x , and (ii.) of the probability that it will not occur along the final portion of the path, dx . This second probability is obviously $a \cdot f(x) \cdot dx$, where a is a constant such that

$$f(x + dx) = f(x) - f(x) \cdot a \cdot dx.$$

Since

$$f(x + dx) = f(x) + f'(x) \cdot dx$$

we have

$$f(x) = b \cdot e^{-ax}$$

where b denotes a constant of integration. Considering that $f(x) = 1$ when $x = 0$, it follows that b must be equal to 1. It now remains to find the meaning of a ; this may be done by considering that if i be the number of collisions suffered by a molecule per second, i must also represent the number of *free paths*. The expression $i = e^{-ax}$ represents the number of these which have values greater than x , so that the number of paths which have lengths lying between x and $(x + dx)$ is given by

$$ie^{-ax} - ie^{-a(x+dx)} = ie^{-ax}(1 - e^{-adx}) = ia \cdot dx \cdot e^{-ax}$$

These paths have a total length equal to $i \cdot a \cdot x dx e^{-ax}$. If this expression be integrated between the limits 0 and infinity the result is the total distance traversed by a molecule in one second, *i.e.*, the mean velocity :

$$v = ia \int_0^{\infty} e^{-ax} x dx = i/a = i \times \text{mean free path.}$$

Putting $l = \frac{r}{a}$, it follows that the probability that a molecule will traverse, without collision, a path of length x will be given by

$$f(x) = e^{-x/l}.$$

It is very easy to show that the *proportion* of molecules for which the free path has a value lying between x and $x + dx$ is $(dx/l)e^{-x/l}$. Thus, out of every 1,000 molecules, only 7 traverse a distance $5l$, only one out of 22,000 traverses a distance $10l$, and so on.

Experimental Determination of the Free Path

The best two experimental proofs of the mean free path consist of the *direct* measurement of the path itself and the direct determination of its distribution. The former method is due to Max Born* and is based on the measurement of the density of a layer of silver deposited on a glass plate by a beam of silver atoms travelling in air at reduced pressure, this density being a function of the distance of the plate from the point of origin of the beam. The apparatus is shown diagrammatically in Fig. 17. A stream of vaporised silver was reduced to a beam of very narrow angle by means of a vertical tube B, and this beam passed through circular holes cut in four brass discs placed one above another at intervals of 1 cm. These discs were cooled by immersion in liquid air and each supported a quadrant the apex of which was on the axis passing through the centres of the circular holes; each quadrant was turned through an angle of 90° with respect to the one below it, and each glass plate thus received one-quarter of the stream of atoms.

The quartz tube was connected with a pump so that the silver could be vaporised at various measured pressures; the density of the deposit was measured photographically. If D_{10} and D_{20} represent respectively the densities on the quadrants 1 and 2 when there is not any gas in the chamber, and if D_1 and D_2 represent the densities when the gas present has a mean free path equal to l , then, if the theory is correct, the following relations hold:

* M. Born, *Phys. Zeits.*, 21, p. 578, 1920.

$$D_1 = D_{10} e^{-x_1/l} \qquad D_2 = D_{20} e^{-x_2/l}$$

where x_1 and x_2 are the distances from the source.

These equations give $l = \frac{x_2 - x_1}{\log(D_1 D_{20}/D_2 D_{10})}$, and hence, from

the densities of the deposits determined photographically, it is possible to deduce the free path of the atoms of silver in air.

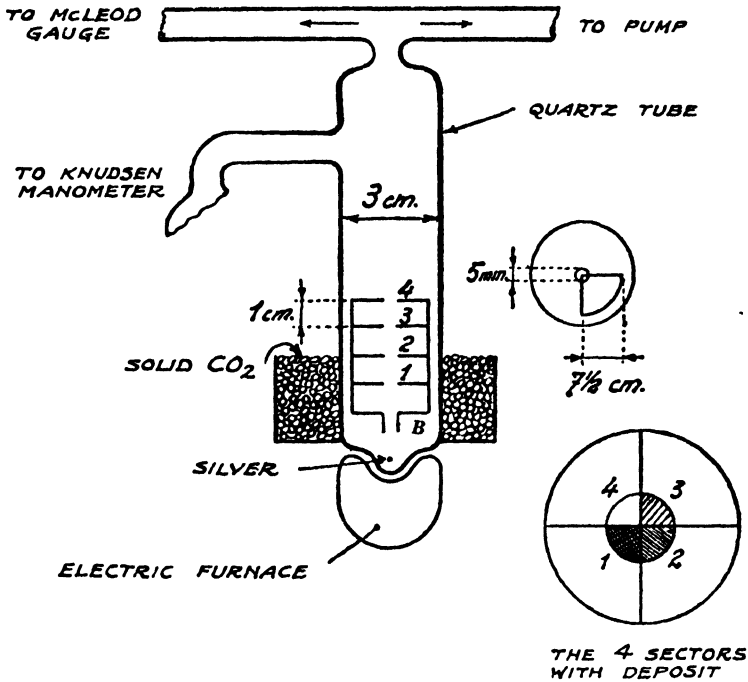

FIG. 17.—Born's experiment.

In these experiments $x_2 - x_1$ was equal to one centimetre, and a series of measurements gave :

$$\begin{array}{ll} \text{for } p = 5.8 \times 10^{-3} \text{ mm.} & l = 1.7 \text{ cm.} \\ \text{for } p = 4.5 \times 10^{-3} \text{ mm.} & l = 2.4 \text{ cm.} \end{array}$$

It will be seen that the product pl is constant, as predicted on the kinetic theory of gases : calculating on this basis, the value of the free path at atmospheric pressure is $l = 1.4 \times 10^{-5}$ cm.

Another experimental investigation by means of which the mean free path can be obtained is that of F. Biely, for a description of which the original paper should be consulted (*Zeits. f. Physik*, Vol. 32, p. 81, 1925).

We shall now see how the mean free path, on which the *viscosity* of a gas depends, can be obtained by calculation from a determination of this latter quantity.

The Viscosity of Gases and its connection with the Mean Free Path

If this connection be known, l can be found, and also Avogadro's number.

Let us return to a consideration of the horizontal disc rotating in air and supported by means of a vertical thread. While the disc rotates, there are some molecules which, having acquired a horizontal component of velocity, rise to the higher layers of air, and, by communicating to these layers the energy contained in this component, cause them to rotate; other molecules descend, encounter layers in rotation, and, in acquiring a horizontal movement, reduce the velocity of these layers; thus after a certain time a steady state is reached in which there is a velocity gradient, *i.e.*, in passing from one layer to another at a distance of one centimetre from it, there is a change of horizontal velocity represented by du/dz .

As an illustration, consider two trains with different velocities, travelling side by side and close together; the passengers in one train throw heavy balls at the other or jump from one train to the other; it is clear that the faster train will have its velocity reduced while the slower train will be accelerated.

A complete theory, which it is unnecessary to consider in detail,* leads to the obvious result that the *viscous resistance* η experienced by a layer of the fluid per unit area when the velocity gradient is *unity* is equal to $\eta = \frac{1}{3} nmvl$, *i.e.*, the resistance increases with the mass of the molecules, their number per unit volume, the mean free path and the mean velocity.

Thus, since nm is the simple density ρ of the gas (the mass per

* See note on p. 177.

unit volume), the coefficient of viscosity may be expressed more simply thus :

$$\eta = \frac{1}{3} \rho v l.$$

This gives the desired means for determining both the *actual dimensions* of the molecules and Avogadro's number N .

First, however, we propose to say something about the coefficient of viscosity, η , which plays an important part in many phenomena.

The result just obtained for the value of the viscosity is due to Maxwell, who published it in 1886, and it is of considerable interest. Since the mean free path is inversely proportional to the density and this increases as the pressure increases, it follows that the *viscosity should be independent of the pressure*. This seems surprising, but it is actually true, and its experimental verification, carried out after Maxwell had deduced it by calculation, forms one of the most elegant and striking proofs of the kinetic theory of gases.

Viscosity can be measured easily ; it is sufficient to take one of those phenomena in which it plays a part and to develop the theory of this phenomenon so as to obtain a formula in which the viscosity η appears. Its value can then be deduced in just the same way as g , the acceleration due to gravity, may be obtained from the expression $s = \frac{1}{2} gt^2$, which gives the distance covered by a falling body in a certain time ; in this case the distance and the corresponding time are measured and the value of g is found.

Now one of the phenomena which can be utilised for determining η is the flow of a fluid through a tube at a moderate velocity.

The mathematical theory of the phenomenon leads to an expression which gives the volume of fluid which passes, I , in terms of the radius r of the tube, its length L and the pressures p_1 and p_2 at the ends of the tube.

$$\textit{The volume of fluid passing } I = \frac{\pi r^4}{8\eta L} (p_1 - p_2).$$

A determination of the amount of flow and of the two pressures

gives the data necessary for calculating the coefficient of viscosity.

Alternatively, it is possible to use, for example, the damping of a mass (a pendulum bob) which oscillates in the fluid the viscosity of which it is desired to measure; the mathematical theory of the oscillatory movement being known, a measurement of the damping gives the viscosity.

It is not possible to give further details of such experiments which Maxwell himself carried out at different pressures. For air the coefficient of viscosity at 15 degrees is 0.00018.

From the theory which shows the viscosity to be independent of the density, it is possible to deduce this curious fact: the speed with which a small sphere falls in a gas is independent of the pressure of the gas; actually the velocity of descent is given by the well-known Stokes law:

$$\text{speed of fall} = \frac{\text{weight of sphere}}{6\pi a\eta}$$

where a is the radius of the sphere.

The weight, actually, is the apparent weight, *i.e.*, the real weight less the weight of gas displaced which, although negligible, varies with the pressure. Since, as has been seen, the viscosity does not depend on the pressure, it must be concluded that a ball will fall in air at atmospheric pressure with the same velocity as in air at a pressure of 10 atmospheres.

This conclusion is confirmed by experiment.

Let us now return to our main argument.

In Maxwell's equation: $\eta = \frac{1}{3} \rho v l$, where ρ is the density, and v is the mean velocity.

Thus everything is known except the free path l , which can therefore be found. For oxygen and for nitrogen under normal conditions, the free path is of the order of one ten-thousandth of a millimetre (0.1 micron). For hydrogen it is approximately double this; at the low pressures obtained in a Crookes tube (one millionth of an atmosphere), it may sometimes happen that a molecule may travel for several decimetres in a straight line without meeting another molecule.

Viscosity and Mean Free Path

Gas.	Viscosity.	M.F.P. in cm
Hydrogen . . .	84×10^{-6}	11×10^{-6}
Oxygen . . .	190×10^{-6}	6.2×10^{-6}
Nitrogen . . .	167×10^{-6}	5.9×10^{-6}
Carbon monoxide .	166×10^{-6}	5.8×10^{-6}

N.B.—The mean free path is given at 0° C. and at a pressure of one atmosphere.

Molecular Dimensions.—Avogadro's Number.—Diameter of the Molecular Spheres of Action

Once the value of the mean free path has been found, it will be seen that Van der Waals' equation :

$$\left(p + \frac{a}{v^2}\right) \left(V - \frac{2}{3} \pi \sigma^3 N\right) = RT$$

combined with the equation $l = 1/(\pi\sqrt{2} \cdot \sigma^2 n)$ gives at once the solution of the problem before us, *i.e.*, that of determining the diameters of the molecules and Avogadro's number N . In fact, in these two equations, the only unknowns are precisely the diameter and the number N of molecules in the gramme-molecule.

Making the calculation in the case of the monatomic gas, argon, we obtain the following result :—

Volume of the spheres of action in a gramme-molecule
(40 gm.) = 7.5 c.c.

Hence *Diameter of the molecule*, $\sigma = 2.85 \times 10^{-8}$ cm.

Avogadro's number $N = 62 \times 10^{22}$ molecules.

Argon was not chosen at random, but because its molecule is monatomic and therefore probably spherical.

For nitrogen, the value found for N is 45×10^{22} , and for carbon monoxide 50×10^{22} , results which are slightly discordant, but as they are of the same order they are worth consideration.

The kinetic energy of the molecules of all gases is $\frac{3}{2} \frac{R}{N} T$; now

that N is known, this value may be calculated ; for example, at the temperature of melting ice ($T = 273^\circ$) it is found that

$$\text{kinetic energy of one molecule} = \frac{3}{2} \frac{R}{N} T = 0.56 \times 10^{-13} \text{ ergs.}$$

The number of collisions suffered by a molecule in one second is obviously the reciprocal of the mean free path ; since the free path varies in general from 5×10^{-6} to 10^{-5} cm., the number of collisions per centimetre is of the order of a hundred thousand ; if the mean velocity be divided by the mean free path, the number of collisions per second is obtained ; the reciprocal of this number is the average time which elapses between two successive collisions.

Thus there is nothing left unknown. It is not without admiration that we look back at the road which has been traversed and which has now led us to such an intimate knowledge of the molecule, and we cannot fail to pay homage to the men like Clausius and Maxwell, who built up from first principles a method of exploring a world of such extremely small dimensions.

The following table recapitulates the values of various molecular quantities :—

Gas.	Root mean square velocity C .	Mean velocity v .	Coeff. of viscosity η .	Mean free path in cm.	Molecular diameter σ .
Hydrogen .	1838 m/sec.	1693 m/sec.	84×10^{-6}	11×10^{-6}	2.8×10^{-8}
Oxygen .	461 ,,	425 ,,	190×10^{-6}	6.2×10^{-6}	3.7×10^{-8}
Carbon dioxide	393 ,,	362 ,,	137×10^{-6}	3.8×10^{-6}	4.7×10^{-8}

Thus it is found that, from the measurement of the compressibility of a fluid, it is possible to obtain, by means of Van der Waals' equation, the value of the constants a and b , and therefore the actual total volume of the molecules $\frac{4}{3} \pi \sigma^3 N$, but by another simple line of reasoning it is possible to arrive at an upper limit for σ . In fact, the diameter σ which occurs in considering the molecular collisions will be very nearly equal to the distance between the centres of the molecules when the body is in the liquid state and at a low temperature. In this state the molecules

cannot be more concentrated than balls piled up one on another ; the volume so occupied by a gramme-molecule of the body as liquid is known, so the value of σ^3N is obtained, and consequently, Avogadro's number.

In this way it has been found for mercury, which is monatomic, that $N = 45 \times 10^{22}$.*

The molecular world is wonderful and curious. A gramme-molecule which, under ordinary conditions, occupies a cube of which the sides are 13 cm. long, contains molecules which are so far apart that only 7 c.c. out of the whole 22,400 are filled with material ; the grains of this powder-like material move like cannon-balls which change their direction one hundred thousand times whilst traversing one centimetre ; their velocity is so great that their energy is measurable, however small their mass may be. But can man make use of it ? In this cube of 22,400 cm. there are 60.6×10^{22} particles in motion, and we are quite unable to visualise this number ; a huge area, 1,000 km. square, if completely covered with particles one millimetre square, would contain only 10^{18} of such particles, *i.e.*, about one-millionth of the number which we are attempting to visualise.

Now it is necessary to explain briefly what is understood nowadays by the *diameter of the molecules*. This expression arose out of the original conception of molecules formed by the physicists who developed the kinetic theory of gases, *viz.*, that of elastic spheres incapable of deformation ; if two such spheres of the same kind are in contact, their diameter is equal to the distance between their centres, and it is then clear how, by means of Van der Waals' equation, or of the data on liquefaction at the *critical* point, or of viscosity measurements, it is possible to arrive at a quantity which, if this conception were a true one, would correspond exactly to the diameter of the molecules. Now, however, since the discovery of the electrons as universal

* This value is obtained from the relation $l = \frac{V}{\pi\sqrt{2} \cdot \sigma^2N}$, where l and V are known.

constituents of the atoms which, in combination, constitute the molecules, these ideas have lost their simplicity. The arrangement of the electrons is not well known; moreover, there is, in the structure of the atom, a "nucleus" which is electrically positive, and further, the manner in which the atoms are combined within the molecule is not completely known. What is certain is that the molecules are complete structures with electrical and magnetic properties, and that forces of attraction and repulsion come into play between them.

It is clear, then, that for a complex structure such as an atom or a molecule, the geometrical definition of diameter loses its meaning, and that actually the various experiments which can be carried out to determine this quantity, based as they are on different pictures of the atom, are bound to lead to different results; actually each experiment measures a quantity which depends on the nature of the experiment itself; in other words, the quantity determined is defined by the nature of the experiment to which the molecule is subjected.

On the other hand, it is certainly true that experiments of different kinds all give for the dimensions of the atoms and molecules numbers which have the same order of magnitude, viz., 10^{-8} cm.

It is possible, for instance, to cause electrons of various velocities to travel through a gas and to deduce the "cross-section" of the molecules from the number of electrons which reach a given distance, this number being measured by means of an electrometer (Ramsauer's experiment). However, the values obtained not only differ from those given by the kinetic theory, but they vary with the velocity of the electrons projected into the gas; for high velocities, the *diameter of the molecules* is less, showing that the electrons may *penetrate* the sphere of action.

The study of crystals, magnetism, the mobility of ions, molecular refraction, etc., all provide different methods of measuring the size of the molecules, but they are, it must be repeated, indirect methods of attack, and do not really give a measurement in the ordinary sense in which we understand the measurement of a length.

Anyone who wishes to become acquainted with the various methods used for finding the molecular dimensions should consult the article by Herzfeld in *Elektronen, Atome, Moleküle*, 1926 (*Handbuch d. Phys.*, Vol. XXII).

Specific Heat of Monatomic Gases—Equipartition of Energy

Monatomic gases are, as the name indicates, those which have a molecule consisting of a single atom ; in addition to mercury, cadmium and zinc, this group contains the *rare gases* of the atmosphere, helium, neon, argon, etc.

These gases, after their discovery, were subjected to very intensive study and research ; the air which, at the earth's surface, is composed of 21 parts by volume of oxygen and 78 of nitrogen—a total of 99 per cent.—contains 0.94 per cent. of argon, a quantity which is readily detectable ; neon is present in the proportion of one part per 80,000 of air ; then comes helium in the proportion of one part in 250,000, and finally the others in still smaller quantities.

The quantity of heat supplied to a monatomic gas is employed in increasing the kinetic energy of translation of the molecules, and it might be thought that a portion would be employed in increasing a rotational movement ; *this, however, is not the case for monatomic gases*, for these behave as if they were composed of rigid, perfectly elastic spheres, so smooth that when struck they are unable to acquire a movement of rotation.

Actually the mean kinetic energy of a molecule is known to be $\frac{1}{2} mC^2$, and for the N molecules in a gramme-molecule the total energy of motion is $\frac{1}{2} NmC^2 = \frac{3}{2} RT$. Hence when the gas is heated at constant volume so that all the heat goes to increase the energy, for every degree rise in temperature, the specific heat due to the velocity of translation of the molecules will be $C_v = \frac{3}{2} R = 12.5 \times 10^7 \text{ ergs} = 2.98 \text{ calories.}^*$

Now for the monatomic gases (helium, neon, argon, mercury)

* 1 calorie = 4.18×10^7 ergs.

it is definitely known that the specific heat given by experiment is just 3 calories per gramme-molecule, and this shows that the molecules do not rotate.

As Perrin observes, this is a very remarkable fact. It would be sufficient to discredit the kinetic theory if there were a single case in which the heat lost by three grams of water cooling through one degree, caused a greater rise of temperature than one degree in a gramme-molecule of any gas at constant volume ; but this has never been found.

The specific heat at constant pressure, C_p , is $\frac{5}{2}R$ for monatomic gases ; actually $C_p = C_v + pdV$, pdV being the part absorbed in increasing the volume by the amount dV . Since by differentiating the equation $pV = RT$ it is found that $pdV = RdT$, it is easy to obtain at once the relation :

$$C_p = C_v + R = \frac{5}{2}RT.$$

For all monatomic gases it may be said, too, that the ratio $\frac{C_p}{C_v}$ must equal $\frac{5}{3} = 1.66$, and this has been verified with extreme accuracy by means of experiments on the monatomic gases helium, argon, mercury, etc.

So far we have, in speaking of the specific heats of gases, indicated that there is a very close agreement between the experimental values and the theoretical values $\frac{3}{2}R$, $\frac{5}{2}R$, $\frac{6}{2}R$, $\frac{7}{2}R$, etc. This agreement between the classical theory and experiment must, however, be accepted with reserve since the matter is really complicated, C_v showing a variation with temperature.

This variation has been studied carefully in the case of hydrogen ; for this gas the specific heat in the region close to 30–55° absolute is $\frac{3}{2}R = 2.98$ calories per degree ; close to 250° abs. it is $\frac{5}{2}R$, and then C_v rises continuously between 500° and 2,000°, reaching and exceeding 6 calories per degree.

Specific Heat (C_v) of Hydrogen

T.	C _v .	T.	C _v .
29	2.98	100	3.42
35	2.98	196	3.62
40	2.98	273	4.84
50	3.01	333	4.91
60	2.99	625	5.08
70	3.04	1,000	5.34
80	3.14	1,400	5.62
90	3.26	2,000	6.34

The explanation of this change in the specific heat will be given in the section on quantum theory (Vol. II, Chap. VIII).

The Specific Heats of Perfect Polyatomic Gases—Degrees of Freedom

For a polyatomic gas such as oxygen, nitrogen, hydrochloric acid, or ammonia, the molecules are not spherical, and the heat supplied is not used solely to increase the kinetic energy of translation; part of it may increase the speed of rotation and possibly another part may be converted (as is supposed) into kinetic or potential energy among the components of the molecule. On this assumption, the total quantity of heat dQ which is supplied to a gas at constant volume is divided into two parts, that which increases the energy of translation (already calculated to be equal to $\frac{3}{2} RdT$) and that used up within the molecule.

The latter portion we may evidently suppose also to be proportional to dT , so that we have :

$$dQ = \frac{3}{2} RdT + \frac{3}{2} R \cdot a dT,$$

where a is the factor of proportionality.

For one degree difference of temperature, $C_v = \frac{3}{2} R (1 + a)$.

In order to find the specific heat at constant pressure we have already seen that we must add R , so that we find :

$$\text{Specific heat at constant pressure } C_p = \frac{R}{2} (5 + 3a).$$

At this stage we may note the very interesting fact that a assumes simple values. Actually the ratio $C_p/C_v = 1.40$ for diatomic gases ; for example :

	C_p	C_v	C_p/C_v
hydrogen (H_2) . . .	6.86	4.80	1.41
nitrogen (N_2) . . .	6.98	4.95	1.40
oxygen (O_2) . . .	6.98	4.95	1.40
carbon monoxide (CO) .	7.00	4.95	1.40

so that for these gases $a = \frac{2}{3}$. Then the polyatomic gases may be considered, such as methane, carbon dioxide, ammonia, etc. For these the ratio $C_p/C_v = 1.33$, so that $a = 1$.

Thus, for these gases, since $C_v = \frac{3}{2} R (1 + a)$, the total energy supplied in the form of heat is double that used in increasing the kinetic energy of translation.

	C_p	C_v	C_p/C_v
ammonia (NH_3) . . .	8.65	6.47	1.33
methane (CH_4) . . .	8.65	6.39	1.31
carbon dioxide (CO_2) .	8.88	6.60	1.30

For more complex molecules, a sometimes becomes equal to $\frac{5}{3}$;

to sum up, the number that expresses the relation existing between the heat which is absorbed in increasing the kinetic energy of translation and that which is converted into energy of movement within the molecule has always a simple value lying between $\frac{2}{3}$ and $\frac{5}{3}$.

To Maxwell and to Boltzmann belongs the credit of giving a complete explanation of these facts. For a spherical molecule there are three possible ways in which its centre of gravity can move corresponding to the three co-ordinates, viz., from right to

left, up and down, and backwards and forwards (to use ordinary terminology) ; it is said to have three *degrees of freedom*, this term being used by analogy with the nomenclature introduced into dynamics by Henri Poincaré, for the number of independent values which must be known in order to specify completely the configuration and position of any dynamical system.

This number expresses the capability of the system for movement. For instance, a point moving in a plane has 2 degrees of freedom ; a punctiform mass moving in space has 3, a solid moving in space has 6, since, in addition to the displacement of its centre of mass, necessitating 3 degrees of freedom, it can rotate in three ways ; a pair of compasses has 7 degrees of freedom, viz., 3 of translation, 2 of rotation of one leg, one of rotation about this leg, and finally one of change of angle between the two legs.

A nut-cracker has 8 degrees of freedom. In surgery, a joint which has become incapable of movement is said to be ankylosed ; thus ankylosis causes the human body to lose one of its degrees of freedom ; if the joint of a pair of compasses becomes so stiff that it no longer allows the angle between the legs to be altered, the number of degrees of freedom of the system is reduced from 7 to 6.

To interpret these remarkable results, it was necessary for Maxwell and Boltzmann to introduce the celebrated principle of the equipartition of energy ; we shall illustrate this by means of a few examples.

If we consider monatomic molecules as of the nature of smooth elastic spheres incapable of transmitting a rotational movement, it is clear that all the heat supplied will be used in increasing the energy of translation ; and since there are three possible motions, all ranking equally, each of the three degrees of freedom will absorb, for each degree rise in temperature, one-third of the total heat supplied, *i.e.*, it will absorb $\frac{3}{2} R$ divided by 3, *i.e.*, $\frac{1}{2} R$.

Given the value of R , this means that the amount absorbed by each degree of freedom per degree rise of temperature will be one calory, or, more exactly, 0.99 calory.

For a gas with two atoms to the molecule, for example, O_2 or N_2 , the simplest idea of the molecule which it is possible to conceive

is that of a system of two homogeneous elastic spheres coupled together in dumb-bell fashion ; since this system has an axis of revolution passing through the centres of the two spheres, a collision cannot affect the rotation about this axis, but the other two rotations may be altered as a result of collisions, *i.e.*, those about the two axes normal to the axis of symmetry.

It is necessary, therefore, to consider two new terms in estimating the total kinetic energy equivalent to the heat supplied.

The doctrine of the equipartition of energy states that each degree of freedom absorbs the same amount of energy for each degree rise in temperature ; it is clear, then, that for a gas with two atoms to the molecule, the specific heat at constant volume is 5 calories.*

For a gas having a rigid molecule with no axis of symmetry, the number of degrees of freedom is 6, and the specific heat is twice that of a monatomic gas ; there will be, then, a group of tri-atomic gases for which $C_v = \frac{1}{2} R \times 6$, *i.e.*, $C_v = 5.94$.

This is the case for aqueous vapour (H_2O), for which at $100^\circ C$. the value of C_v is exactly 5.94.

Finally, if the molecules are not rigid, the new degrees of freedom which are introduced lead to an increase of 1 calory per degree each. Thus nitrous oxide (N_2O) has a specific heat C_v equal to 6.93.

We shall see in what follows, however, that there are certain difficulties in this theory of specific heats and that the theory of quanta has provided a brilliant solution ; the difficulties arise from the fact that the specific heats are not, as implicitly assumed in what has just been said, the same at all temperatures ; while argon at $0^\circ C$., at 100° , at $1,000^\circ$, and at $2,000^\circ$ always has the same specific heat $C_v = 2.97$, hydrogen at $0^\circ C$. has a specific heat equal to 4.80 at $500^\circ C$., its specific heat has become 5.25, and at $1,000^\circ C$. it is 5.6.

We are here confronted with a definite and striking fact ; the specific heat falls as the absolute zero is approached and tends to the value 2.98 calories, *i.e.*, to the value corresponding to 3 degrees of freedom.

* Or, more exactly, $4.95 = \frac{1}{2} R \times 5$.

The same applies to oxygen and to nitrogen (Nernst's experiments). Everything occurs as if the rotational degrees of freedom gradually disappeared, as if the molecules behaved more and more like homogeneous spheres incapable of rotation. We see that if, as the temperature rises, the fresh degrees of freedom appear simultaneously in all the molecules, the molecular heat should show a discontinuity at some temperature ; if, on the other hand, they do not appear at the same time in all the molecules, but are subject to the occurrence of molecular impacts, the specific heat will increase progressively, as is found experimentally to be the case. Thus the continuous increase of the specific heats of the non-monatomic gases at high temperatures is not irreconcilable with the equipartition hypothesis.

However, there is one matter which is still obscure, and that is the manner in which the rotations disappear at low temperatures.

Specific Heats of Solids—Simple Demonstration of Dulong and Petit's Law

Let us consider the molecules of a solid as elastic spheres—monatomic molecules—held in positions of equilibrium by the action of neighbouring molecules but capable of executing small vibrations about these equilibrium positions. The kinetic energy of a molecule is given by the expression :

$$\textit{kinetic energy} = \frac{1}{2} m (u_1^2 + u_2^2 + u_3^2),$$

where u_1 , u_2 , u_3 are the three components of the instantaneous velocity.

The potential energy, expressed as a function of the co-ordinates x , y , z of the position of the centre of mass, is given by :

$$\textit{potential energy} = a (x^2 + y^2 + z^2).$$

That the potential energy should have this form will be clear from the fact that it depends on the product of a force—proportional to the elongation—and the elongation itself, as in the case of a pendulum ; and the law of elasticity for a solid—reaction proportional to the deformation—leads to the supposition that the force tending to restore the atom to its position of equilibrium is proportional to the distance by which it is displaced.

When proceeding to the consideration of low pressures the influence of the friction term η/ϵ becomes noticeable, and the flow G which occurs under a specified difference of pressure ($p_1 - p_2$) no longer decreases in direct proportion to the pressure. Knudsen's experiments showed that the quantity flowing passed through a minimum value, then rose and tended towards a *limiting value* (for $p = 0$) which was independent of p ; this means that a steady state is reached in which the phenomenon becomes independent of the idea of viscosity. This will be explained in further detail in the following section.

To give a concrete idea of the way in which the flow for a given change of pressure ($p_1 - p_2$) varies with the mean pressure p , we may say that Knudsen finds that for carbon dioxide flowing along a certain tube, Poiseuille's law (proportionality of G and p) holds from high pressures down to about 2 mm. of mercury. From $p = 2$ to $p = 0.4$ mm. the amount of flow decreases, but

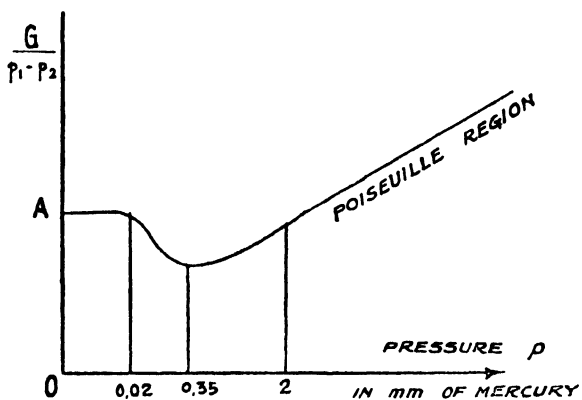

FIG. 18.—Variation of the gas flow with the pressure.

at a constantly diminishing rate, until at $p = 0.35$ mm. it reaches a minimum; then the flow rises again, and at about 0.02 mm. it attains a constant value, which is maintained unaltered for all attainable low pressures.

We shall see in the next section how Knudsen has been able to obtain by calculation the value of the *limiting flow*, which is represented in the figure by the ordinate OA.

Very Rarefied Gases and the Kinetic Theory

It has been seen that the mean free path varies inversely as the pressure; from values of the order of a ten-thousandth of a millimetre at ordinary pressures, it may attain values of several centimetres or even several decimetres at low pressures. Maxwell's expression for the mean free path is, as already stated,

$$l = \frac{1}{\pi\sqrt{2} \cdot n\sigma^2}$$

where σ is the molecular diameter and n is the number of molecules in a cubic centimetre.

For nitrogen and oxygen $\sigma = 3.7 \times 10^{-8}$ cm. ; further we may recall that $n = (\text{Avogadro's number})/22,400 = 2.70 \times 10^{19}$ for a gas under normal conditions.*

Hence it is found that, at a pressure of one atmosphere and at 0° C., the

$$\text{Mean free path} = \frac{1}{11.5 \times 10^{19} \times 13.6 \times 10^{-16}} = \frac{1}{15 \times 10^4} \text{ cm.}$$

If the pressure were one ten-millionth of an atmosphere, the mean free path would be about 60 centimetres.

It is, then, possible to obtain vacua of such a high order that the mean free path equals and exceeds the dimensions of the apparatus which contains the gas. Collisions of the molecules among themselves then become very rare and do not enter into consideration if the pressure is very low. It must be remembered that in practice the means for producing a vacuum are capable of reducing the pressure to a millionth of a millimetre of mercury. The result is a remarkable alteration of all the properties of the gas ; the study, both experimental and theoretical, of these properties, has led to a whole series of interesting conclusions with which the name of the physicist Knudsen has been especially associated.

To give some idea of the methods used in this work, we may content ourselves with outlining the way in which the flow of a rarefied gas in a fine tube leads to Knudsen's formula.

It is known that the flow of a gas along a capillary tube is, at normal pressures, in accordance with Poiseuille's law :

$$\text{Mass passing per unit time : } G = \frac{\pi r^4}{8\eta l} (p_1 - p_2) \frac{pM}{RT},$$

where l = length of tube, p = mean pressure of the gas, M = molecular weight of the gas.

The gas behaves during its passage as if it adhered to the walls and its velocity increased from zero at the walls to a maximum at

* 22,400 is the number of cubic centimetres in a gramme-molecule of any gas.

the centre of the stream ; there is no discontinuity of velocity in the vicinity of the walls. It is known that Poiseuille's law is completely verified experimentally and that it provides a means for finding the coefficient of viscosity, η , from a measurement of the flow G .

When, however, the pressure of the gas is so low that the mean free path of the molecules is no longer very small in comparison with the radius of the tube, especially if this latter be a capillary, this law no longer holds good, and the gas behaves as if it no longer adhered to the walls ; there is a sharp discontinuity in passing from the moving gas to the stationary wall.

For very high vacua, in fact the highest ordinarily attainable, it has been shown experimentally that, below a certain fall of pressure, there is a limiting rate of flow which is independent of the gas pressure ; the conception of viscosity then loses its meaning ; in fact, when the effects of the inter-molecular collisions are negligible, *i.e.*, when the flow is governed solely by the collisions of the molecules with the walls, the phenomenon changes from one of *viscous flow* to one of *molecular flow*.

Now, if the gas were at rest, Maxwell's law of distribution of velocities would certainly hold ; if, however, the gas be in motion, it can only be used as a first approximation. As regards the directions in which the molecules leave the wall after a collision with it, it appears that, at the high vacua now under consideration, the molecules are, as it were, absorbed by the wall and re-emitted in all directions according to the law of probability.

After these two remarks we can at once describe how it is possible to obtain the expression for the mass of gas which flows per second along the tube.

The axial force on the wall is per sq. cm. $\{(p_1 - p_2)/l\} \frac{1}{2}r$, and the fall of pressure along a centimetre of tube is $(p_1 - p_2)/l$, so that the axial force is $\{(p_1 - p_2)/l\} \pi r^2$, and this is distributed over the wall of one centimetre length of the tube, *i.e.*, over an area $2\pi r \cdot 1$.

The force which acts on each centimetre of the tube can be expressed in another way ; it is, in fact, equal to the momentum which the walls of the tube receive per unit area in the direction

of the axis. But we know that the number of molecules which strike a square cm. of the walls per second is $\frac{nC}{\sqrt{6\pi}}$ (see p. 63),

where n is the number of molecules contained in one cubic centimetre and C^2 is, as usual, the mean square of the velocities; further, each molecule has a momentum mu along the axis of the tube; hence the momentum sought is

$$mu \frac{nC}{\sqrt{6\pi}} = \frac{p_1 - p_2}{2l} \cdot r \quad \dots \quad (\alpha)$$

Now nm is the density of the gas, and the mass flowing per second is $G = \pi r^2 u \times \text{density}$.

If in this expression we replace unm by the value obtained from equation (α) we have, on eliminating C by means of the relation $\frac{1}{3} MC^2 = RT$,

Mass of gas flowing per second,

$$G = \pi r^2 u \times \text{density} = \frac{\sqrt{\pi^3} r^3}{\sqrt{2} l} (p_1 - p_2) \sqrt{\frac{M}{RT}} \quad \dots \quad (\beta)$$

This is Knudsen's equation.

As will be seen, the viscosity no longer appears in the result; the movement of the fluid takes place as a mass, and no longer in separate streams exerting on each other a mutual friction; the pressure of the gas has no effect on the flow, and this is governed by a single variable $(p_1 - p_2)$; this shows that if the pressure is halved, the density of the gas is halved, but it flows twice as fast.

Formula (β) has been verified experimentally, and explains the facts perfectly.

We may now pass on to describe a practical application.

It is clear that the momentum communicated by the gas per second to unit area of the walls, or more simply the acting *force*,

is $mu \frac{nc}{\sqrt{6\pi}}$; putting for mn and for C the values obtained from

the equations obtained previously, viz.

$$p = n/2h, \quad \frac{1}{3}MC^2 = RT, \quad C^2 = 3/2hm,$$

we have

the axial force per unit area (otherwise the pressure) exerted by the

gas on the walls is

$$\frac{up}{\sqrt{2\pi}} \sqrt{\frac{M}{RT}}.$$

This expression has a direct application in the *molecular manometer*. This is an interesting instrument which is used for measuring very low pressures with a sensitivity approaching one-millionth of a millimetre of mercury.

It comprises a horizontal disc which is caused to oscillate rapidly in the gas, the pressure of which is being measured. The oscillation is induced by means of a rotating magnetic field outside the instrument, this field acting on a magnet attached to the disc; another disc parallel to this one is suspended just above it by means of a fine quartz thread, and it is induced to rotate by reason of the rapid movement of the disc which is revolving at a distance of a few millimetres below it.

The velocity with which the molecules move past the stationary disc (*i.e.*, the quantity u in the problem just considered) is ωr , where ω is the angular velocity of the rotating disc; the *force* exerted on the annular element of area $2\pi r dr$ has the value:

$$\frac{p}{\sqrt{2\pi}} \sqrt{\frac{M}{RT}} \times \omega r \times 2\pi r dr.$$

To convert to moments it is necessary to multiply by the radius r . Integrating all the elementary moments from zero to r , the total moment tending to rotate the disc is obtained; this produces a proportional torsion in the suspension thread, so that, equating the value of the moment acting on the disc with that of the force tending to prevent this rotation, we have:

$$\text{angle of twist} = Ar^4 \omega p \sqrt{M/RT},$$

where r = the radius of the disc,

ω = the angular velocity,

p = the pressure to be determined.

The constant A contains the numerical factors which appear

at the end, as well as the constant of torsion of the suspension thread, which is naturally known.

It will be seen that this apparatus is actually an *absolute manometer*, for the quantities M , T , R , and ω are known ; the angle of twist, too, can be measured by means of a beam of light reflected from a small mirror attached to the quartz thread suspension.

The unknown, p , can at once be calculated. The sensitivity increases with increase of the velocity imparted to the rotating disc, a velocity which can be regulated.

Pumps for High Vacua

Considering how very important high vacua have now become in industrial practice for the preparation of X-ray tubes and valves for radio work, we ought to devote many pages to describing modern pumps and the apparatus used for measuring the very low pressures which can now be obtained ; but we cannot treat the subject at any length, and so must refer the reader to special books.* We can, however, give a short account of the most important apparatus. Gaede (1913) devised an interesting application of the property of rarefied gases in his *molecular pump*, which is capable of giving a high vacuum in a short time. It is based on the so-called *principle of the moving wall*. A moving wall drags the neighbouring gas with it, communicating to the molecules which rebound from it a velocity component parallel to that of the wall, this component having a *mean value* which is not zero. It is as if the molecules condensed on the wall and were then evaporated from it after a short interval of time, leaving it in all directions. If, now, the wall be moving in a certain direction, all the molecules take, on the average, a velocity component parallel to that direction. In this way it is possible to produce a suction effect on the gas if the initial pressure is sufficiently low. If this condition is not fulfilled, the collisions between the molecules destroy the effect of the wall.

The diagram of Fig. 19 represents the pump invented by

* See, for instance, *La Technique du vide*, by DUNOYER ; *High Vacua*, by DUSHMAN.

Gaede; it will be seen that in the bronze cylinder, which is the rotating part, there are cut several circular grooves, those nearer the centre being deeper so as to afford a larger channel for the flow of the more rarefied gas. The projecting teeth (C) fit into these grooves, and both together make up a kind of comb. The inner surface of the containing vessel is very close (0.1 mm.) to the moving face of the cylinder. At two points in the vessel, n and m , are openings which form the outlets of two tubes, one

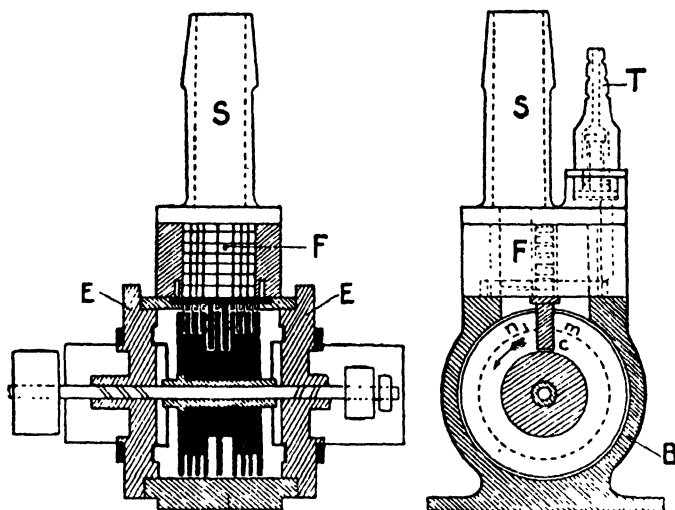

FIG. 19.—Gaede's molecular pump.

of which leads to the apparatus to be evacuated, the other to a space in which a backing vacuum of several tenths of a millimetre is maintained.

There is a series of grooves (F) so arranged that the gas accumulated in the space n_1 is carried into the space n_2 , which is opposite to m and symmetrical with it about the median plane. The outlet from m_2 communicates with n , and in this way the apparatus is equivalent to two neighbouring pumps in series. The number of revolutions may be 6,000 to 8,000 per minute.

Holweck's molecular pump (see *Journal de Physique*, Vol. 4, p. 534, 1923) depends on the same principle as Gaede's. The rotating part is a smooth cylinder, while the stationary containing

cylinder has no projections but spiral grooves which increase in depth towards the outlet. The clearance between the fixed and moving parts is 0.03 millimetre.

Another type of pump for high vacua is based on the phenomenon that a jet of vapour from boiling mercury drags molecules of gas along with it (Langmuir's and Volmer's pumps).

What are the vacua attainable with these pumps? One might justifiably say that the degree of rarefaction which it is possible to obtain with the Holweck pump or with the mercury vapour pump is unlimited. This must be understood in the sense that the limit to the rarefaction produced in a vessel is no longer set by the pump, but by other things such as the cleanness of the walls (the complete elimination of oils which give off vapour), the presence of occluded gases or of gaseous films adhering to the metallic parts, taps, etc.

The pressures which may be attained by eliminating to the utmost possible extent all the above-mentioned sources of gas are frequently below 10^{-7} mm. of mercury. At present, however, there is no instrument which will give an accurate measurement of the vacua obtained. By using electrical methods of estimation, some physicists claim to have obtained pressures of the order of 10^{-15} mm. of mercury. It is generally considered that the technique of high vacua has reached the stage of giving residual pressures of the order of 10^{-7} mm. of mercury. To give an idea of what this vacuum means it is sufficient to note that there will remain about 5 milliards of molecules per cubic centimetre. Yet this number is so small compared with the number of molecules present under ordinary conditions, that it is difficult to detect the presence of these residual molecules by experimental means.

We may, just as a matter of interest, compare this lowest attainable pressure with the difference of pressure which the human ear is capable of detecting. Experiments carried out within the last few years have shown that the human ear can, for frequencies lying between 500 and 8,000, respond to differences of pressure of 0.001 bar (1 bar = 1 dyne per sq. cm.), equivalent to a pressure of about 10^{-7} mm. of mercury.

Our ear, then, is sensitive to pressures of one-millionth of a gram per square cm. These feeble sounds correspond to a power of the order of 10^{-15} watt.* This is the so-called *limit of audibility*.

Manometers for Measuring very low Pressures

These are of several kinds. The principle of Sutherland's manometer is illustrated in Fig. 20.

A thin disc of glass is suspended between two horizontal plates N by a thread which carries a small mirror S, which is viewed through the window I by means of a telescope. The suspension head L is of iron and can be rotated by means of an external magnet so that the disc can be set into oscillation as a horizontal pendulum. Its vibrations, however, are damped and the damping can be observed with the telescope. If S_1 and S_2 be two successive amplitudes, the theory of damped oscillations shows that the ratio S_1/S_2 is constant with respect to time and that, in fact, $S_1/S_2 = e^{aT}$, where T is the period.

It will be seen at once that this will give the pressure of the gas present, which is responsible for the damping.

Dushman's manometer is that to which reference has already been made ; a diagram is given in Fig. 21.

BB is a glass bulb, A is the rotating disc made of aluminium, and connected by means of the stem II to the magnetic needle NS ; GG is the Gramme ring which maintains the oscillation ; C is the

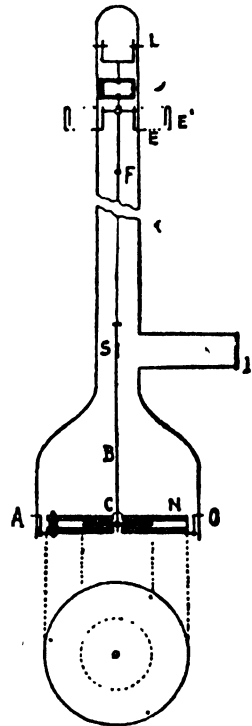

FIG. 20.—Viscosity manometer.

* The average intensity of human speech at 10 cm. from the mouth is 0.01 microwatt, i.e., 0.1 erg per second ; therefore the excess pressure is 2 bars as compared with 10^6 bars, the normal pressure. The Americans in speaking use a power of 10 to 15 microwatts (the lower figure corresponds to speech with intervals of silence, the higher number to uninterrupted speech).

mica disc, F its thread, M the mirror indicating the angle through which the mica disc is turned.

The *ionisation valves* which act as manometers at low pressures are, in essence, three electrode valves like those used in radio-telegraphy. The principle on which their use is founded is that if, in a gas at low pressure (argon for example), a stream of electrons emitted from an incandescent filament travels towards an

anode, these electrons ionise the molecules of the residual gas in the bulb so long as their velocity u , due to the accelerating field, is such that $\frac{1}{2}mu^2 > V.e$ (kinetic energy $>$ total work required). This will be explained in Vol. II, Chap. II; m indicates the mass of the electron, e its charge, V the ionisation potential of the gas, *i.e.*, that fall of potential sufficient to remove an electron from the atom. The positive ions produced can be collected on an electrode and the intensity of the ionisation current so obtained measures the pressure of the gas.

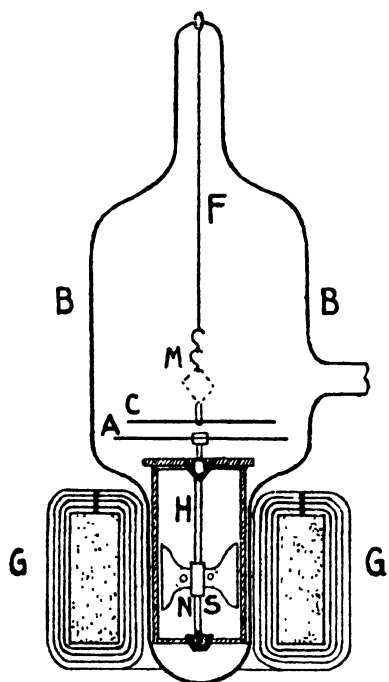

FIG. 21.—Molecular manometer of Langmuir and Dushman.

in double spiral form wound round it. This serves as the anode, and a cylinder outside the two filaments acts as the collector.

Once the curve connecting the pressure with the ionisation current is known, the instrument is ready for use.

The kinetic theory of gases successfully provided the means for calculating the velocity with which the molecules moved, the

number of collisions which they made per second, their dimensions and the number of them in a cubic centimetre. In spite of these wonderful successes, however, it did not succeed in inspiring unbounded faith in the atomic conception of matter, perhaps on account of the extremely great or extremely small magnitudes which occurred in the results. Ostwald, a chemist of great repute, in a memorable lecture delivered in 1904, in which he relied solely on the principles of kinetics, opposed the new scientific tendency and the new doctrine. Cannizzaro, a strong advocate, was at the end of his career, but there appeared in Perrin an energetic supporter and an acute investigator who could pile fact upon fact and research upon research.

A phenomenon which early exerted an enormous influence on the development of the new physics, by demonstrating plainly the discontinuity of matter and the independent movements of the particles composing it, was the Brownian movement. It was to this, then, that Perrin devoted his wonderful genius for refined experiment, while Einstein formulated the underlying theory.

BIBLIOGRAPHY

- DEL LUNGO. "Teoria cinetica dei gas" (1920).
L. B. LOEB. "Kinetic Theory of Gases" (1927).
R. CLAUSIUS. "Die Kinetische Theorie der Gase" (1889).
J. H. JEANS. "Dynamical Theory of Gases" (1921).
L. BOLTZMANN. "Vorlesungen über die Gas Theorie" (1910).
G. JAEGER. "Fortschritte der Kinetischen Gas Theorie" (1919).
E. BLOCH. "Theorie cinétique des gaz" (1925). (English translation by P. A. Smith, 1924.)
L. DUNOYER. "La Technique du vide" (1924). (English translation by J. H. Smith, 1926.)
K. JELLINEK. "Lehrbuch der Physikalischen Chemie" (1928).
"Ergebnisse der exakten Wissenschaften," Vol. III, 1924.
G. W. C. KAYE. "High Vacua" (1927).

CHAPTER IV

FLUCTUATIONS

Thermodynamics and Statistical Mechanics.—Entropy and Probability

THE principle of the conservation of energy is an absolute principle valid equally well for a single molecule and for a mass of gas containing a large number of molecules. On the other hand, Carnot's principle* (1824) is a *statistical* result which holds only on the macroscopic scale, that is, for phenomena averaged over many molecules. If the temperature of a gas which has been carefully isolated from all external influences is not varying, the average kinetic energy of its molecules, which serves as a measure of the temperature, remains constant. The kinetic energy of a particular molecule, however, taken in the interior of the gas, is continually changing, owing to collisions, and at a point where by chance the molecules are moving more rapidly, the temperature is a little greater than that determined. Where certain molecules of lower velocity collide with the wall the pressure will be less, and where the molecules are moving upwards against the force of gravity the temperature locally must be lower than that observable for the gas taken as a whole.

Thus when attention is concentrated on elements of volume which are sufficiently small, the statistical character of physical laws is clearly apparent, and from the point of view of kinetic theory the uniformity of density and temperature presumed by thermodynamics are realised only on the average and on condition that we do not attempt to verify them for volume elements not containing an immense number of molecules. In reality, there occur *fluctuations* about the average state, which although small and irregular, are in certain cases perceptible, that is to say, accessible to experiment. It is evident that these fluctuations

* The second law of thermodynamics.

will be more pronounced the smaller the elements of volume investigated.

Regarding the question from another point of view, we may say that if it is attempted to explain in terms of the mechanics of molecules, an irreversible phenomenon such as the diffusion of two gases one into the other, taken at the same temperature and pressure, a serious difficulty is encountered. The movements of the molecules are, in fact, supposed subject to classical mechanics, and are therefore essentially reversible, *i.e.*, capable of being reproduced in the reverse sense. If at a given moment one imagines the velocities of all the molecules exactly reversed, the gas will pass through again in the opposite order, the series of its previous states. In particular, if a mixture arising from the mutual diffusion of two different gases is considered, the two gases will become separated once more. Now experience demonstrates the impossibility of such a spontaneous separation which would be opposed to Carnot's principle, although perfectly compatible with the laws of mechanics.

Maxwell, faced with this difficulty, devised an ingenious explanation which later was to be the germ of the complete solution given by Boltzmann. Carnot's principle is established by "macroscopic" observations, that is to say, observations referring to complex systems formed of a great number of molecules. The magnitudes which are dealt with in thermodynamics—the temperature and pressure of gases, for example—define merely an average state for all the molecules contained in a fixed volume. There is no experiment which shows that the principle is valid for microscopic phenomena, *i.e.*, phenomena on the molecular scale. It is, in fact, possible to imagine molecular mechanisms which would enable experiments in contradiction to the principle to be carried out. Consider, for example, a gas at uniform temperature occupying two chambers separated by a wall, and imagine a minute and agile spirit able—by sliding aside a tiny window—to open and close for a brief instant a small aperture in the separating wall. This imp could by suitable manœuvring allow the more rapid molecules of one chamber to pass into the other, and the slower molecules of the latter to pass in the reverse direction into

the first chamber. He would by doing this have created an inequality of temperature without the performance of external work, in defiance of Carnot's principle. Now what Maxwell's demon could contrive to accomplish without loss of energy might come about through a sequence of fortunate coincidences among the molecules, without external intervention. Carnot's principle cannot therefore be applied in following the phenomenon in detail. It will be found to be invalid by an intelligence sufficiently refined to deal with the molecules individually.

The study of Brownian motion confirms this point of view according to which Carnot's principle loses its absolute significance. The equilibrium configurations which the principle allows us to predict as rigidly fixed, correspond in reality only to average aspects about which matter is in continuous vacillation. Fluctuations occur which become more and more important as the number of molecules present decreases. It is to Boltzmann that we are indebted for the development of this idea and for the explanation of why Carnot's principle, which ceases to be valid when phenomena are studied on a scale approaching the molecular scale, has never been found wanting in the investigation of "macroscopic" or average effects.

The magnitudes we measure are mean values calculable for maximum probability, and measurements carried out on sufficiently small volumes deviate from the mean value by an amount which varies with position and with time. This is the phenomenon of "fluctuations."

Consider a mass of gas. According to the kinetic theory, to define the state of the gas an enormous number of independent data (parameters) must be given, namely, the co-ordinates and velocity components of all the molecules. On the practical side the mean values of certain magnitudes extended over a large number of molecules, actually over the whole mass, are investigated (pressure, volume, temperature).

As the precise state of motion of each single molecule is not accessible to observation, recourse is had to probability methods, and a statistical mechanics is constructed. The construction of the statistics means the discovery of the law of distribution of the

molecular velocities, and this law has been duly given in p. 54. It is clear, however, that one and the same mass of gas definitely determined from the thermodynamic standpoint, can occur in practice with very numerous and varied combinations of the molecular parameters. Using an expression due to Gibbs and Boltzmann, we may say that a great number of different *complexions* of the molecular parameters can correspond to the same macroscopic state. A given state of the gas is the more probable the greater the number of complexions for which the state is realised. It is natural to admit that given a gas in any state initially, it will tend towards the more probable states. The number of complexions W corresponding to a given state is taken as the measure of the probability of that state. As the entropy, like the probability, also tends always to increase, the combination of the two concepts into one can be arrived at simply by assuming the entropy S to be an increasing function of the probability W :

$$S = f(W).$$

The form of the function f is determined immediately by the fact that for two independent gases the total entropy is the sum of the partial entropies ($S = S_1 + S_2$), and if W_1 and W_2 are the probabilities of the states of the two gases, these states being independent, the probability of their simultaneous occurrence equals the product $W = W_1 \times W_2$. It follows that the entropy must be a logarithmic function of the probability. Suppose, in fact,

$$S = k \log W \quad . \quad . \quad . \quad . \quad . \quad . \quad (1)$$

The two entropies of the separate gases, expressed in terms of the corresponding probabilities, are :

$$S_1 = k \log W_1 \qquad S_2 = k \log W_2.$$

The total entropy S should be given in terms of the probability W of the whole system, by

$$S = k \log W.$$

This follows immediately from

$$S = S_1 + S_2 \text{ and } W = W_1 \times W_2.$$

The fundamental relation (1) established originally by Boltzmann

for a gas is now general. It connects in an extremely simple way the entropy of a system with the logarithm of its probability. As a consequence of this result, the second law of thermodynamics becomes a statistical truth applicable only to systems which depend on a large number of molecular parameters. The equilibrium state predicted by thermodynamics, *i.e.*, the configuration of maximum entropy, now appears as the most probable but not the sole possible configuration of the system which in the course of time passes through all the possible configurations in the proportion of their probabilities.

The most probable configuration is merely the one most frequently assumed ; it will be more predominant the greater the complexity of the system. Fluctuations about this state must, however, occur, and it will shortly be seen how the relation (1) not only allows the magnitude of the fluctuations in any particular case to be predicted, but also enables molecular magnitudes to be deduced from experimental measurements of the fluctuations.

Nowadays we express ourselves in such terms as, it is extremely improbable that the density at a point in a gaseous mass in equilibrium will vary in the ratio 1 to 2 ; it is most unlikely that a hectogramme weight hung by a rope will rise a metre in the air as a result of Brownian motion ; it is enormously improbable that two gases mixed together will separate spontaneously by diffusion, and so on.

Existence of Fluctuations—Utilisable Energy

From the point of view of the kinetic theory, then, the uniformity of density and temperature assumed in thermodynamics is only realised for average values and on condition that it is not attempted to extend the verification down to too small elements. Actually thermal equilibrium is a mere semblance masking the agitation of the molecules. Deviations from the mean state, *i.e.*, fluctuations, occur, and although these are certainly small, it is possible for them to become accessible to human observation. A micron cube drawn about a point in a gaseous mass does not contain always the same number of molecules, or, in other words, has not always the same density, and the temperature at the point

is fluctuating, but the problem is to reveal these deviations with a thermometer. Also the pressure exerted on a square micron of the wall is not the same in successive instants.

To conclude this recapitulation, the existence of fluctuations is contrary to Carnot's principle in its old rigid form, but is compatible with it if one regards the principle as a statistical law. In that case we say simply, that thermodynamic equilibrium corresponding to maximal entropy represents a statistical equilibrium corresponding to the most probable state, the other states not being excluded but being less likely the more they deviate from the most probable state.

The study of fluctuations is approached in the light of the above remarks. The general law was given by Einstein. Smoluchowski applied it to a number of interesting cases which we shall mention.

Consider to begin with a gas. It has been seen that the entropy is related to the probability of the system by Boltzmann's relation $S = k \log W$. Passing from the equilibrium state characterised by the maximum entropy S_0 , to which corresponds the maximum probability W_0 , to the neighbouring state characterised by the probability W , we have :

$$S - S_0 = k \log \frac{W}{W_0},$$

from which it follows that

$$W = W_0 e^{\frac{S - S_0}{k}}.$$

But given two entropies, S and S_0 , it is clearly possible to pass from the state corresponding to the entropy S_0 to the state corresponding to S , maintaining the temperature constant, and in

that case the difference $(S - S_0)$ is merely the ratio $\frac{L}{T}$ of the energy utilisable externally (the external work) to the temperature,

since $dS = \frac{dQ}{T}$.

Thus we may write :

$$\text{probability } W = Ae^{\frac{L}{kT}} \dots \dots \dots (2)$$

where A is a constant.

This established, we show that the constant k occurring in the above expression for the probability W is merely $\frac{R}{N}$, where R denotes the perfect gas constant and N is Avogadro's number. Only a sketch of the proof will be given in order to avoid complications and to enable the more interesting conclusions to be reached without delay.

In dealing with Maxwell's law for the distribution of velocities in a gaseous mass, it was seen that the probability of a molecule having components of velocity u, v, w , is expressed in this way :

$$\begin{aligned} &\text{probability of a molecule having kinetic energy } E_{\text{kin}} \\ f(u, v, w) &= ae^{-hm(u^2 + v^2 + w^2)} = ae^{-2h\left(\frac{mV^2}{2}\right)} = Ae^{-2hE_{\text{kin}}}. \end{aligned}$$

But the discussion of the distribution of velocities was made without reference to the height, varying from instant to instant, to which the molecule rises in its motion. Gaseous masses were considered, which on the whole were of limited height. It was always kinetic energy that was referred to and never potential energy, or, as one might say, the molecules were assumed to have *mass* but not *weight*. When, however, gaseous masses of unlimited height are considered, it is necessary to admit that a rising molecule acquires potential energy equal in amount to the kinetic energy lost. It is easy to see how, by an extension of the above formula, the probability of a molecule having total energy E comes out to be :

$$\begin{aligned} &\text{probability that a molecule has energy } E \\ ae^{-2hE} &= ae^{-\frac{NE}{RT}} \dots \dots \dots (3) \end{aligned}$$

where $2 hT = \frac{N}{R}$ (see p. 61).

We are only concerned here with the relationship between (2) and (3). The latter refers to a single molecule and not to an assembly, the reverse being the case for (2). The fact remains, however, that the probability for the assembly is given by

the product of the probabilities for the individuals, and by multiplying together expressions of the type (3) for the different molecules, the exponentials add up and the result must reduce to (2). From this relation the following noteworthy result can be deduced :

$$\frac{1}{kT} = \frac{R}{NT}$$

from which we have

$$k = \frac{R}{N} = 13.7 \times 10^{-17}$$

as was asserted. k is termed *Boltzmann's constant*.

To sum up, the probability W that a gaseous mass will be in a state from which the utilisable energy E can be withdrawn, is :

$$W = Ae^{-\frac{NE}{RT}}$$

We now come to the last step in the derivation of an extremely important result. If the above expression for W is compared with that giving the probability of occurrence of an error Δ (Gauss' Law), which takes the form :

$$W = \frac{\alpha}{\sqrt{\pi}} e^{-\alpha^2 \Delta^2}$$

we see that just as the constant α^2 is related to the mean square of the error, by the very simple formula : $\frac{1}{2\alpha} = \text{mean square of the error}$, so the mean value of the external utilisable work E is related to $\frac{N}{RT}$ by an equivalent equation. This is at once seen to be

Mean utilisable external work :

$$\frac{RT}{2N} = \frac{8.32 \times 10^7}{121.2 \times 10^{22}} \cdot T = 6.85 \times 10^{-17} \cdot T.$$

This important and simple result we might have anticipated. It tells us that the utilisable work equals one-third of the kinetic energy of a molecule, the latter being given by $\frac{3}{2} \frac{RT}{N}$.

To show how this relation comes about, we consider a mass of gas contained in a parallelopiped, the walls of which contain

innumerable minute pistons arranged close together and normal to the wall. (See Fig. 22.)

In a given time, a large number of molecules, say a milliard, will impinge on the wall; but an equal number carrying the same energy will strike the pistons of the opposite wall. The

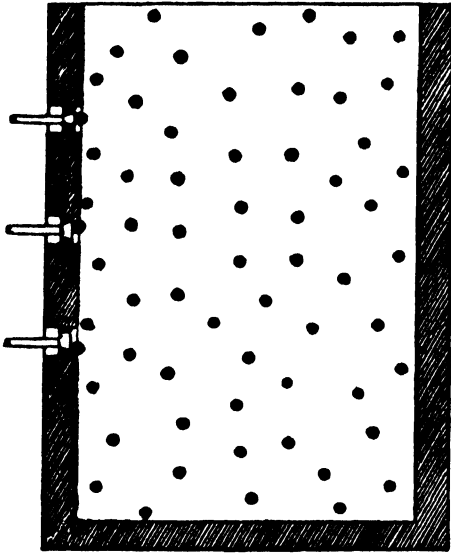

FIG. 22.

kinetic energy of a molecule is known to be on the average

$\frac{3}{2} \frac{RT}{N}$, but the energy which

can be abstracted from a molecule striking a piston amounts on the average to

only $\frac{RT}{2N}$, that is, a third part

of $\frac{3}{2} \frac{RT}{N}$, since only one of

the components of velocity comes into account.

If it is desired to perform external work by making use of the system of pistons for converting the kinetic energy

into work, it is evident that the amount obtainable from the mass of gas will be very small, because in a given time the numbers of molecules received by the pistons on the right and on the left respectively will be equal and the velocities in the two groups will on the average be the same. At first sight it appears that the utilisable work must be zero. That is not the case, however.

If the time interval be mentally restricted so that instead of a milliard a much smaller number of molecules is involved, until finally the symmetry associated with large numbers no longer holds, and the impact of a molecule on the right-hand wall is not accompanied by an impact on the left-hand wall, then it will be possible to extract from the whole mass of gas (however large),

on the average, energy of amount $\frac{RT}{2N}$.

A question which will occur to the reader is how the entropy which is defined by the relation $dS = \frac{dQ}{T}$ can conform to the apparently entirely different definition, $S = k \log W$.

It is easy to see that the two definitions agree. Differentiating $S = k \log W$, we have $dS = k \frac{1}{W} dW$. Now dW , the increment in the number of complexions, is clearly given by the quotient $\frac{dQ}{\frac{R}{N}T}$, for dQ represents the increment of the quantity of heat, and each complexion (degree of freedom) absorbs an amount $\frac{R}{N}T$.

$$\text{Thus} \quad dS = k \frac{1}{W} dW = \frac{R}{N} \frac{dQ}{\frac{R}{N}T} = \frac{dQ}{T} \frac{1}{W}$$

In this way the *statistical significance* of entropy is clearly brought out. If heat is added to a body at a certain temperature, the quotient $\frac{dQ}{T}$ is a quantity proportional to the immediate increment in the complexions W .

General Law of Fluctuations (Einstein)

The result obtained above for a gas is assumed to hold for any system which, although apparently in a steady state, is subject to very small, spontaneous fluctuations from which external work can be derived. For example, a spring or a tuning fork will execute spontaneous oscillations of average potential and kinetic energies of amount $\frac{RT}{2N}$. Considering a closed electric circuit spontaneous variations of the current will occur, the energy of which is always given by the equation $\frac{RT}{2N} = \frac{LI^2}{2}$, where L denotes the inductance of the circuit, and I is the maximum value of the current passing. This relation furnishes a value for I .

To ascertain the range of the spontaneous oscillations of a spring, we equate the quantity $\frac{RT}{N}$ to $\frac{bx^2}{2}$, where b is the constant of deformation of the spring, *i.e.*, the force required to produce unit deformation, $x = 1$.

This general law of fluctuations is due to Einstein. It has been established here only for gases, but it is easy to see how it can be extended to any system.

Smoluchowski's Theory of Density Fluctuations in a Fluid—Critical Opalescence

We wish now to determine the law relating the probability W to the "condensation" which takes place in a gas owing to fluctuations of density.

Consider an element of volume of a gas, ϕ , containing n_0 molecules of mass m . If v is the specific volume (volume of unit mass), mn_0v represents the actual volume occupied by the n_0 molecules. The external work performed in passing from the pressure p_0 to the pressure p equals :

$$L = mn_0 \int_{v_0}^v (p - p_0)dv \dots \dots \dots (1)$$

which is the sum of the partial works. If this integral is developed in a series stopping at the first term, we find :

$$L = mn_0 \left[\frac{\partial p}{\partial v_0} \frac{(v - v_0)^2}{2} \right] = mn_0 \frac{v_0^2}{2} \gamma^2 \frac{\partial p}{\partial v_0} \dots \dots (2)$$

γ has been put equal to $\frac{v - v_0}{v_0}$, which clearly represents the

instantaneous *condensation*.

We know that for a perfect gas $pV = RT$, where V is the volume of a gramme-molecule. Thus $V = v_0Nm$ and $pv_0mN = RT$. It follows that $\frac{\partial p}{\partial v_0} = -\frac{RT}{mNv_0^2}$, and inserting this value in (2) we obtain

$$L = -\frac{n_0}{2} \gamma^2 \frac{R}{N} T.$$

Finally, since the probability of a state for which the corresponding available work is L , equals

$$W = Ae^{\frac{NL}{RT}}$$

we have, assuming the value for L just found, *probability associated with the condensation of specific volume γ* :

$$W = Ae^{-\frac{n_0}{2}\gamma^2} \dots \dots \dots (3)$$

This relation is none other than the well-known error law of Gauss expressed in the formula

$$W = \sqrt{\frac{B}{\pi}} e^{-B\Delta^2} d\Delta$$

and we are well acquainted with the relation which exists between the constant B and the mean error. In our case the *mean error* is the fluctuation of the condensation. Both the simple mean of the error and the mean square are known as functions of B , the former being $\frac{1}{\sqrt{\pi B}}$ and the latter $\frac{1}{2B}$.

Thus making use of (3), we have immediately :

$$\text{mean square of the condensation } \gamma^2_{\text{mean}} = \frac{1}{2B} = \frac{1}{n_0}$$

This is a very important result. Instead of volumes we think now of the number of molecules contained therein. Since this

number is proportional to the volume, $\frac{n - n_0}{n_0}$ may be written in

place of $\frac{v - v_0}{v_0} = \gamma$, and we have, employing the equation

$$\gamma^2_{\text{mean}} = \frac{1}{n_0},$$

$$\left(\frac{\Delta n}{n}\right)_{\text{mean}}^2 = \frac{1}{n_0} \text{ or } \frac{(\Delta n)^2_{\text{mean}}}{n_0^2} = \frac{1}{n_0}$$

and finally, $(\Delta n_0)^2 = n_0$.

This last relation is also written in the form :

$$\overline{\Delta n} = \sqrt{n}$$

The mean deviation increases with the square root of the number of particles concerned in the observation.

If in a large restaurant the average number of glasses n broken in a day equals 100, the fluctuation of this number will amount on the average to 10, where it is understood that in arriving at the fluctuation, the square root of the average of the values of Δn^2 obtained daily, is to be used.

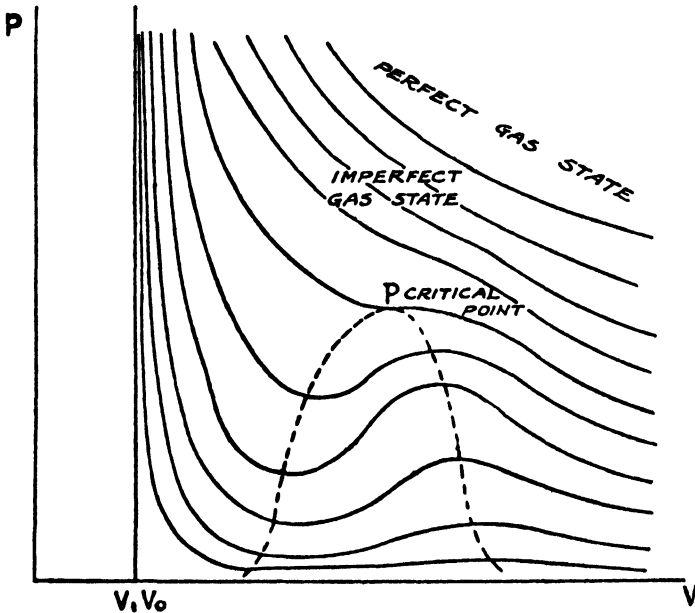

FIG 23.

It can easily be shown that the average condensation γ , obtainable by taking the arithmetic mean of the values $\frac{v - v_0}{v_0}$, is given by :

$$\text{average condensation } \gamma = \sqrt{\frac{2}{\pi n_0}}$$

For a gas at normal density, there are 60×10^{23} molecules contained in 22,400 c.c. In a cubic centimetre, therefore, the mean fluctuation will be of the order of 10^{-10} . In this case there

can be no hope of experimental verification. If the volume considered were a 1 micron cube, the mean fluctuation would be rather larger, and it would amount to 8 per cent. for a very small space containing only 100 molecules.

The case is altered in favour of much larger fluctuations of density if the gas is in the neighbourhood of the critical point. It may be recalled here that at the critical point the compressibility curve of the gas, the curve showing the connection between the pressure and the specific volume, becomes horizontal over a certain length, and possesses a point of inflection, so that for a small variation of the pressure, there occurs a very marked change in the volume.

The curve then not only has a horizontal tangent, but for a certain length is truly horizontal. (At the point P in Fig. 23.)

Analytical geometry indicates that at the point of inflexion the derivatives $\frac{\partial p}{\partial v_0}$, $\frac{\partial^2 p}{\partial v_0^2}$ will both be zero. Reconsidering the development in series of the integral $\int_{v_0}^v (p - p_0) dv$ which was previously confined to the first term, it will obviously be necessary to repeat the calculation, taking into account terms after the first. At the place where the characteristic equation of the perfect gas $pV = RT$ was introduced, in the case of a gas near to liquefaction we must employ in the analysis the equation of an imperfect fluid which obeys, not the simple law, but a modified form such as that of Van der Waals.

The expression arrived at is in fact the following :

mean fluctuation of the condensation at the critical point

$$\gamma_{\text{mean}} = 1.13/\sqrt[3]{n_0}$$

independently of the nature of the fluid.

Thus it is clear that a small volume containing 10^8 molecules can give rise to a sensible fluctuation, for $\sqrt[3]{10^8} = 100$, and we are now in the region of a 1 per cent. effect.

The example just given, $n_0 = 10^8$, corresponds to the consideration of fluctuations occurring in a small cube whose dimensions are

of the order of the wave-length of visible light, and the result obtained explains why highly compressed fluids near the critical point appear opalescent and emit bluish light (critical opalescence). The path of a pencil of light through the fluid then becomes visible just as in air charged with smoke. The opalescence is stable, and is the effect of a slight heterogeneity of the fluid in which there occur contiguous regions of sensibly different density. Some swarms of molecules are condensing, other swarms are expanding, the range of the variations being such that the effects produced are perceptible to human observation.

We now observe that an emulsion, a kind of fluid with visible molecules, will also exhibit fluctuations of density, or, as it is better to say, fluctuations of condensation, $\frac{n - n_0}{n_0}$. From the experimental measurement of these it is possible, by counting the particles, to verify Smoluchowski's formula and to arrive in this way at the value of Avogadro's number, as will now be seen.

***Determination of Avogadro's Number from the Fluctuations of Particles in Emulsions and from Critical Opalescence**

The particles in emulsions behave like gas molecules. Emulsions obey the gas laws, the osmotic pressure taking the place of the usual elastic pressure. The fluctuations in the concentration of the particles are measurable by photographing in successive instants a given layer of the emulsion, which must of course be in equilibrium, and then counting the relative numbers of particles. It will thus be possible to determine if the average value of the

condensation γ equals $\sqrt{\frac{2}{\pi}} \frac{1}{n_0}$ and if the mean square of the condensation equals $\frac{1}{n_0}$, as required by the theory.

Moreover, if the volume under observation is ϕ , it is easy to show, using the analysis reproduced above, that

$$\gamma^2_{\text{mean}} = \frac{1}{n_0} = - \frac{RT}{N} \frac{1}{\phi v_0} \frac{1}{\partial p}$$

The meaning of the symbols has already been given ; v_0 is the specific volume and $\frac{\partial v_0}{\partial p}$ the compressibility when the temperature is kept constant.

Considering an emulsion which, as mentioned above, is a kind of fluid with visible molecules, the compressibility is known from the law of change of concentration with height. The specific volume is also known, and the data necessary to derive Avogadro's number N from the equation just given are all available. Obviously the constancy of the values of N obtained provides a further verification of Smoluchowski's theory. Using this method N was found to be 60×10^{22} .

The theory was completed by Keesom, who set out to find the *intensity of the diffused light in critical opalescence*.

The theory considers the refractive index μ of a particle which produces elementary diffraction, the refractive index μ_0 of the surrounding medium, and the wave-length λ of a monochromatic light ray, and leads to the following expression for the intensity of the light scattered laterally in a direction at right angles to that of the incident beam, by a small element of volume ϕ , the intensity of the incident light being put equal to unity :

$$\frac{2\pi^2\phi^2}{\lambda^4_0} \left(\frac{\mu - \mu_0}{\mu_0} \right)^2$$

Thus the scattered light intensity varies inversely as the fourth power of λ , which explains why, if the incident light is white, the scattered radiation will be blue, spectral colours of small wave-length being diffracted most. But Lorentz' theory indicates that for light of a given wave-length, the expression $\frac{1}{d} \frac{\mu^2 - 1}{\mu^2 + 2}$ remains constant with respect to variations of the density d of the medium. A simple differentiation shows that

$$\frac{\mu - \mu_0}{\mu_0} = \frac{(\mu_0^2 - 1)(\mu_0^2 + 2)}{6\mu_0^2} \frac{d - d_0}{d_0}$$

The ratio $\frac{d - d_0}{d_0}$ is merely the condensation considered in the

preceding paragraph, where density fluctuations were discussed.

The mean fluctuation we know to be $\frac{RT}{\phi N v_0} \frac{\partial v_0}{\partial p}$.

Observing that $\lambda_0 \mu_0 = \lambda$, the quantity of scattered light per cubic centimetre according to Keesom's theory assumes the form

$$i = \frac{\pi^2}{18\lambda^4} (\mu_0^2 - 1)^2 (\mu_0^2 + 2)^2 \frac{1}{-v_0 \frac{\partial p}{\partial v_0}} \frac{RT}{N}$$

The details of the calculations, which are not essential, have been passed over. The result puts us in possession of a new method for the determination of Avogadro's number, for all the quantities occurring in the formula can be measured with the exception of the single unknown N . Measurements made on ethylene whose critical temperature is at 11·18 degrees absolute gave, at 12·18 degrees for the ratio of the intensity of the yellow incident light to that of the scattered light, the value 1 : 0·0008. The compressibility was known from curves analogous to those of Fig. 23. The index of refraction μ_0 for the wave-length of the light used and the specific volume were also known, so that in the above expression N remained the sole unknown and could be determined.

The Blue of the Sky and its Relation to Avogadro's Number

It is well known that the path of a ray of light traversing a medium containing powder in suspension is visible. It is this lateral scattering which frequently renders the sun's rays visible in the air, and advantage is taken of the effect in ultramicroscopic observation. The diffracted opalescent light, as has been seen, will tend to be blue because the different monochromatic colours are differently diffracted, the violet being sixteen times as intense as the red of double the wave-length, which follows from Keesom's result.

Lord Rayleigh in 1871* developed a remarkable theory† in which he supposed that the molecules of air, widely separated and immersed in the void, would act in the same way as the particles of a powder and become diffracting centres, because their refractive

* *Phil. Mag.*, 1871 and 1899.

† This, in fact, was Keesom's starting-point.

index would be different if only by a very small amount from that corresponding to a vacuum. Since rays of short period are the most diffracted, the blue colour assumed by the sky when viewed in a direction perpendicular to the sun's rays is explained. It is, moreover, difficult to admit that the effect is due to the existence of atmospheric dust, because the blue of the sky is no less pronounced when it is observed on high mountains, in wooded areas where there is no trace of the dust which infests the air in the near neighbourhood of the ground. If the phenomenon is due to the molecules singly, then it is closely related to that presented by condensed gases, where the diffracting centres are clusters of molecules in a ceaseless and orderless process of formation and dissolution. It is not difficult to realise how the electromagnetic theory developed by Lord Rayleigh (1842-1919) leads to an expression for the diffuse light of the sun which is completely analogous to Keesom's and to the more complete solution of Einstein, to whom we owe, among many other things, the electromagnetic theory of opalescence.

In the air we have actually to deal not with a pure gas but with a mixture. It may be assumed without sensible departure from the truth that the refracting powers of the components are the same.

We take, then, Keesom's expression

$$i = \frac{\pi^2}{18} \frac{1}{\lambda^4} (\mu_0^2 - 1)^2 (\mu_0^2 + 2)^2 \frac{RT}{N} \frac{1}{-v_0 \frac{\partial p}{\partial v_0}} \dots \dots (1)$$

per c.c. of fluid, and assume that the diffuse light of the sky depends on fluctuations in the density of the air.

It follows from Mariotte's law that $-v_0 \frac{\partial p}{\partial v_0} = p$. As μ is equal approximately to unity, for the coefficient $\mu_0^2 + 2$ the value 3 can be substituted.

(1) becomes then :

$$i = \pi^2 \frac{1}{2\lambda^4} (\mu_0^2 - 1)^2 \frac{RT}{Np}$$

i = intensity of the light emitted laterally by 1 c.c. of gas.

Lord Rayleigh's theory leads to just such an expression for the diffuse light of the sky, obtained by integrating the light diffracted by the individual molecules assumed arranged perfectly at random. In the result is given the ratio of the brightness obtained at the focus of a telescope objective pointed in turn at a given region of the sky and directly towards the sun. The region observed is defined by its zenith height (an angle α) and the angle with the sun's rays β . These two angles must occur in the final result, which will also contain the number of molecules N (representing the concentration of diffracting centres) as well as the atmospheric pressure upon which the concentration also depends.

Rayleigh's calculation, it may be noted, takes no account of the reflecting power of the ground, which may be considerable, as for example when the ground is covered with snow. It furnishes yet another method for the determination of N . The first indications of a derivation on these lines were based on the measurements of Quintino Sella, who from the top of Mt. Rosa made comparisons between the brightness of the sun at a given height and the brightness of the sky at the zenith. Subsequent measurements by French and American * physicists have led by this method to values of N ranging round 60×10^{22} , a value with which we are already familiar from numerous other methods. Thus no doubt remains as to the correctness of the theory, and the blue of the sky is shown to be one of those phenomena which, as Perrin puts it, translate the structure of fluids in equilibrium into the realm of human observation.

In Chaps. V, VIII, and in Vol. II, Chap. VI, we shall have occasion to discuss other applications of the theory of fluctuations.

BIBLIOGRAPHY

Theorie du Rayonnement et les Quanta, Solvay Conference (1912).

M. SMOLUCHOWSKI. *Acad. of Sciences of Cracow* (1907). *Ann. d. Physik*, 25, p. 205, 1908.

W. H. KEESOM. *Ann. d. Physik*, 35, p. 591, 1911

A. EINSTEIN. *Ann. de Physik*, 33, p. 1275, 1910.

J. CABANNES. *Ann. de Physique*, 15, p. 5, (1921).

R. FÜRTH. *Handbuch der Physik* (1929), Vol. IV.

* Bauer and Moulin.

CHAPTER V

ELECTRONS AND POSITIVE RAYS

The Atom of Electricity

It was in 1833 that Faraday showed that the passage of a given quantity of electricity through a solution containing a chemical compound of an element resulted in the deposition at the electrode of a fixed and unvarying quantity of this element, whatever the nature and concentration of the compound in solution ; this implies that every atom reaching the electrode is accompanied by the same unit quantity of electricity. When, somewhat later, it was found that all the atoms which were chemically monovalent carried the same quantity of electricity, that divalent atoms carried twice as much, and that, generally, the valency was strictly proportional to the quantity of electricity carried by the atom, the atomic theory of electricity was virtually discovered.

But however clear the conclusions to be drawn from the laws of electrolysis ought to have been, they remained quite unfruitful until the end of the century as regards their interpretation from the point of view of the nature of electricity and its connection with matter.

Maxwell's theory, and the striking experiments of Hertz which brought it to a triumphant conclusion, had distracted the thoughts of physicists from the existence of atoms of electricity and concentrated attention on the ether and on the waves which were transmitted through it and could be polarised and diffracted, as these showed that light must be considered solely as an electromagnetic vibration.

It was not until 1874 that Stoney, in Belfast at a meeting of the British Association, and later (1881) Helmholtz, demonstrated the deduction of outstanding importance which could be drawn

from Faraday's laws of electrolysis; the quantity of electricity which passes through an electrolyte is composed of particles all equal to each other, and independent of the chemical nature of the matter which carries them. Each atom of matter always carries, during electrolysis, a whole number, equal to its valency, of atoms of electricity.

When a gramme-atom of a monovalent ion, for example, 107.9 grammes of silver, is deposited at the electrode, it is always accompanied by the passage of the same quantity of electricity, viz., 96,494 coulombs.*

Since one coulomb is equal to 3×10^9 C.G.S. electrostatic units, we may write the relation between the coulomb and the $N.e$ charges of which it is composed as follows:—

$$N.e = 96,494 \times 3 \times 10^9$$

where N is Avogadro's number.

Taking for N the value 60.6×10^{22} , which is obtained by a critical averaging of the figures obtained by various methods, the value of the atom of electricity is found to be

$e = 4.77 \times 10^{-10}$ C.G.S. electrostatic units, or 1.59×10^{-19} coulomb.

Cathode Rays

Those physicists who, thirty years ago, studied the phenomena of the passage of electricity through gases, were most happily inspired, for among the maze of intricate phenomena which they observed, there are some of extreme simplicity in which the properties of individual atoms of matter and of electricity are clearly indicated.

In analysing these facts, they started on a road which led them straight to an intimate knowledge of matter, and modern physics is based on the results of their labours.

Cathode rays, which were intensively studied by Crookes in 1879, were one of the first phenomena in which it became clear that there was a universal constituent of matter, viz., the electron;

* Chemists have given the name 1 *Faraday* to this quantity of electricity, but, in order to avoid confusion with the unit of electric capacity, Professor Parravano has proposed that it should be called 1 *Davy*.

these rays appear, as is well known, when an electric spark passes through a tube in which there is a fairly high vacuum, *e.g.*, a millionth of an atmosphere. Opposite the cathode the glass vessel is seen to glow with a bright green fluorescence. The cathode rays are invisible; they produce a fluorescence in the bodies which they happen to strike; they are propagated in straight lines; if the plate forming the cathode is plane, they form a beam of parallel rays; if the cathode is concave, all the rays converge towards its centre of curvature and produce a heating effect.

They are corpuscular in character; that is to say they consist of a stream of negative particles. This fundamental property

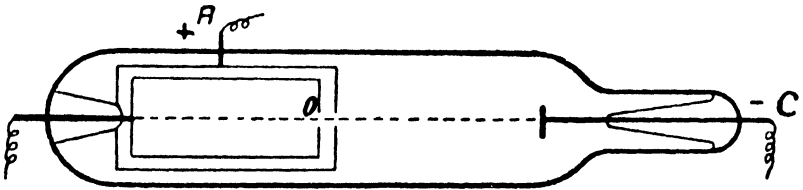

TO ELECTROSCOPE

FIG. 24.—Perrin's experiment.

was suggested by Lenard and demonstrated in a very elegant manner by Perrin (see Fig. 24).

The rays from the cathode enter an aluminium cylinder connected with the leaves of an electroscope; the cylinder forms the collector. In order to avoid any external disturbances which might arise from electric charges localised, for instance, on the walls of the vessel, this cylinder is surrounded with a metallic shield connected with the case of the electroscope.

The cathode rays can enter through a small hole *O* cut in the anterior face of the cylinder. When the tube is in action the electroscope is negatively charged, showing that the rays carry a negative flow coming from the cathode. It is important to notice in this connection that putting a piece of thin aluminium foil over the hole *O* reduces the charge on the electroscope but does not entirely bring it to zero. Lenard has shown that it is possible to study the cathode rays outside a tube if this is provided,

at the end opposite the cathode, with an opening covered with a piece of thin aluminium foil. The rays succeed in penetrating this foil and so pass into the air outside the tube.

The cathode rays are deviated by a magnet or, more generally,

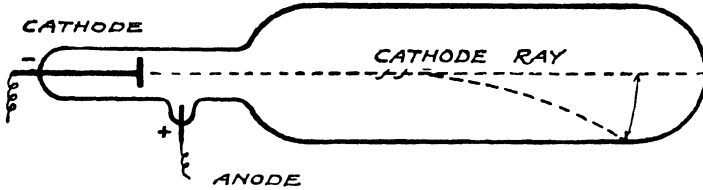

FIG. 25.—Deflection of the cathode stream in a magnetic field.

by a magnetic field, just as if they formed a current of negative electricity flowing from the cathode.

If the tube be placed between the poles of a magnet so that the north pole is in front of the plane of the picture and the south pole behind it, the field is directed through the paper, and under these conditions the cathode rays are bent downwards (see Fig. 25). This is the direction in which, according to electromagnetic laws, an ordinary current passing from right to left would be deviated, or a negative current flowing from left to

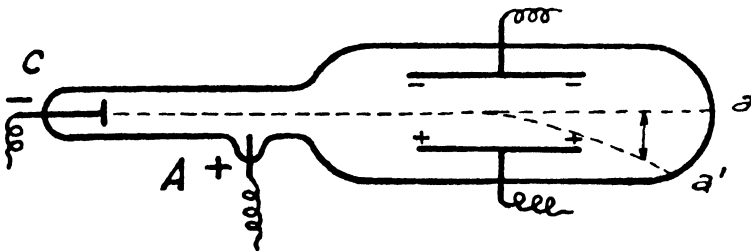

FIG. 26.—Deflection of the cathode stream in an electric field.

right. If the stream, after having passed the anode, travels between two electrified plates with charges of opposite signs, the electric field deflects it towards the positive plate (see Fig. 26).

The cathode rays have the property of giving rise to Röntgen rays (X-rays); in fact these rays result whenever the cathode stream strikes the glass wall of the vacuum tube or any solid body placed in the path of the beam.

Fig. 27 shows another form of the experiment on the deviation of the cathode particles ; the vacuum tube contains the anode *A*, which is perforated, the cathode *C*, which is raised to incandescence by means of a current which can be controlled, and finally *E*, the luminescent screen, coated with calcium tungstate or zinc silicate ; when the tube is operated, the screen shows a bright spot which is situated on the straight line joining the filament with the hole in the anode.

The spot is controlled by the electric field and by the magnetic field. If the metal rod *T* is charged positively, the spot rises ; if a north magnetic pole is brought close to the tube at *N*, the

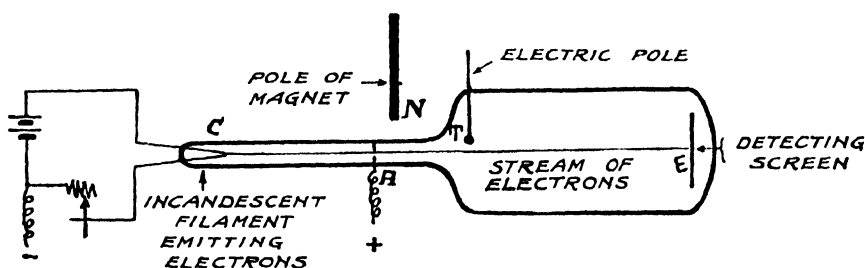

FIG. 27.—Production of cathode rays by an incandescent filament.

spot is displaced horizontally. This shows very clearly that there are negative electric charges moving in the tube away from the incandescent cathode.

It is these immaterial particles, all equal and each having a charge of 1.59×10^{-19} coulomb, that form a ray as they move in a straight line towards the anode.

An agglomeration of these particles—the electrons—does not form any chemical substance and is not material, but it has, nevertheless, a physical existence. How is it possible to establish the value of the charge and the true nature of these particles, of this atomic dust ?

Charge and Mass of the Electron

Experiments which, although simple, are yet some of the most ingenious and fruitful ever conceived by physicists, have been devised to determine the electrical charge, the velocity and the

mass of these particles ; the phenomenon first used was that of the deviation of the particles in a magnetic field. When one of these particles carrying the charge e moves in a uniform magnetic field H produced artificially outside the tube, the path of the particle ceases to be rectilinear and becomes an arc of a circle, owing to the force continuously applied to it.

The radius of curvature r of this circle is determined by the fact that the centrifugal force mv^2/r is balanced by the electromagnetic force acting on the particle, viz., $e.v.H$, m being the mass of the particle.

Hence it follows that $mv^2/r = e.v.H$. The field strength H and the radius of curvature r can be measured so that there remain two unknowns, the velocity of the particles v and their specific charge e/m . Another experiment is needed, therefore, to enable these to be determined.

J. J. Thomson first devised (1897) a method of measuring simultaneously the quantity of electricity $Q = ne$ carried by n particles of the cathode stream and their kinetic energy

$W = \frac{1}{2} nmv^2$; Q was measured by collecting the particles in an auxiliary tube, while W was obtained by means of a thermopile.

Eliminating n from the two expressions $Q = ne$ and $W = \frac{1}{2} nmv^2$ gives $m/e = 2W/Qv^2$ and this equation, when combined with the expression obtained above, $v = Hr(e/m)$, gives values for the velocity v and for the specific charge.

The other method, also due to Thomson, is based on the deviation of the cathode rays in an electric field. This causes the negative particles to approach a plate positively charged and to follow a parabolic path, exactly in the same way as a projectile which is directed horizontally has its path deflected downwards under the action of the earth's gravitational force. For a weight

P the vertical drop in time t is $h = \frac{1}{2} (P/m)t^2$; hence for a cathode particle which in time t traverses a distance $L = vt$, the fall is :

Displacement caused by the electric field

$$h = \frac{1}{2} \frac{Ce}{m} \cdot \frac{L^2}{v^2} \quad \dots \quad (1)$$

where C is the vertical electric field.

If the cathode stream—conveniently restricted to a narrow pencil—strikes a screen covered with a fluorescent material, the downward displacement of the spot of light produced by the rays can be seen, and the measurement of this displacement h gives the first equation connecting the ratio e/m with the velocity v . The other equation is derived from a similar experiment carried out with a magnetic field; if this field is vertical, the cathode stream is displaced horizontally, and this displacement also can be measured. If the field strength is H, the deflecting force is Hev and hence the acceleration is Hev/m .

The displacement is therefore

Displacement due to the magnetic field

$$D = \frac{1}{2} \frac{Hev}{m} \frac{L^2}{v^2} = \frac{1}{2} H \frac{e}{m} \frac{L^2}{v} \quad \dots \quad (2)$$

and thus from measurements of D and h , since L , H and C are known, the specific charge e/m and the velocity v can be deduced from the equations (1) and (2).

Let us now examine the results of the experiments which have just been briefly described. The velocity of the particles is enormous; it greatly exceeds the highest velocity observed for stars; by varying the voltage applied to the tube it is easily possible to obtain velocities lying between 30,000 and 60,000 kilometres per second. Electrons with this velocity would reach the moon in five seconds. In certain experiments it has been possible to study electrons having a much higher velocity, *e.g.*, in the neighbourhood of 260,000 km./sec., a velocity which is very close to that of light.

Measurements of the ratio e/m , the charge of the electron divided by its mass, have given the value 1.77×10^8 coulomb/gram for this quantity.

Now from the charge e carried by the gramme-atom of hydrogen in electrolysis and its mass, which is unity, the ratio obtained

by electrolytic experiments is $e/m = 96,494$ coulomb/gram, so that, comparing the two ratios, it is seen that the first is about 1,840 times as large as the second.

Whilst the velocity of the cathode particles, in accordance with theory, varies as the square root of the applied voltage V (since the work done in carrying a particle from the potential of the cathode to that of the anode is $V \cdot e = \frac{1}{2} mv^2$), the ratio e/m is independent of the nature of the residual gas in the tube, is constant, and is also independent of the nature of the cathode.

By making use of high voltages it is possible to give the electrons a velocity of 150,000 km. per second, *i.e.*, half the velocity of light ; now it is found that for very high velocities the specific charge becomes a function of the velocity ; for moderate velocities (less than 10,000 km. per second), however, the ratio e/m is, as has been said, sensibly constant. From the known value of e/m and the value which we have already given for e , it follows that :

$$m = 9 \times 10^{-28} \text{ gramme.}$$

The cause of the variation of e/m is to be found in Einstein's principle of relativity ; we will here confine ourselves to remarking that e/m is variable because the mass m which, on the principles of the classical mechanics, is absolutely constant, varies with the velocity in accordance with the expression already established :

$$m = m_0 / \sqrt{1 - v^2/c^2}$$

where m_0 is the mass on the basis of the classical mechanics and c is the velocity of light ; this shows that, for values of v not greater than 0.1 or 0.2 c the variation of m , and hence also that of the specific charge e/m is inappreciable.

For cathode rays of 100,000 volts, $v/c = 0.627$ and m/m_0 becomes equal to 1.28, *i.e.*, the mass has increased appreciably.

For certain values of velocity attained in the case of the β -particles emitted from radioactive substances, experiment gives a value for m/m_0 equal to 7 ; the mass, then, is increased seven times at such velocities ; this is no negligible effect.

So far we have spoken of the ratio e/m between the charge and the mass of the electrons, although we have stated that the

electron has no mass in the material sense ; what mass, then, can it have ?

It should here be recalled that a light ball of cork which is electrified and in movement requires more energy to acquire a given acceleration than does a similar non-electrified ball moving with the same velocity ; this being so, it is at once apparent that, since mass and inertia are interchangeable ideas, a charge will be equivalent to a mass even though it may not be connected with any material, as in the case of the electrons.

Cathode Ray Oscillographs

We must first describe briefly the mode of operation of the classical Braun tube from which oscillographs have been derived.

A beam of cathode rays emitted from the cathode traverses the tube in a straight line ; a metallic diaphragm with a small aperture reduces the cross-section of the beam which strikes a fluorescent screen placed at the end of the tube ; a bright spot then indicates the position of the point at which the cathode particles strike the screen. The fluorescent material may be, for example, calcium tungstate.

If, now, an electric field be set up in a direction perpendicular to the axis of the tube, the luminous spot is displaced, and, if the field be an oscillating one, it will be seen to trace out a line on the screen.

To observe directly the way in which the field to be studied varies as a function of the time, it is sufficient to spread out these oscillations in the perpendicular direction by means of some device which will give a uniform transverse motion.

It is possible to look at the image of this spot by reflection in a plane mirror rotating about an axis parallel to the deflection, or else the image can be photographed by means of a stationary lens on a photographic film which moves rapidly in the direction perpendicular to the oscillations produced by the field to be studied.

The Braun tube lends itself very well to the study of phase differences between two sinusoidal effects of the same frequency, since all that is necessary is to act upon the beam with two mutually perpendicular fields each governed by one of the two effects to be studied. What is seen then is an apparently stationary ellipse, the shape of which gives the difference of phase which is to be determined.

The Braun tube has, however, the disadvantage that it requires a high voltage for its operation. From it there have been developed the present-day cathode ray oscillographs which work on a low voltage since the electrons are not emitted as a result of the electric discharge but owing to the thermionic emission from an incandescent filament.

Cathode ray oscillographs, then, are instruments by means of which it is possible to detect and record a transitory effect, even of the shortest duration ; the basis of this possibility is the fact that the extremely minute mass of the electron enables it to acquire a relatively large velocity component in the minute interval of time during which a disturbing field can act upon it. The electron stream, therefore, follows quite faithfully, and without any inertia, the variations of the electric or magnetic fields, no matter how rapid these variations may be. The electron stream may be produced, for example, by

using as the cathode a platinum ribbon covered with the oxide of one of the alkaline earths (as in the Western oscillograph) ; the cathode stream impinges on a screen, or a photographic plate, which thus gives a record of the phenomenon.

A whole range of instruments designed for studying electrical phenomena of very short duration have been based on this principle ; in 1922 Dufour constructed an oscillograph in which the vacuum was obtained by means of a molecular pump, and in which an electron stream impinged on a photographic plate. A magnetic field displaced the point of impact in a direction perpendicular to that corresponding to the action of the phenomenon being investigated. The inventor succeeded with this apparatus in obtaining direct registration of electric oscillations having a frequency of 220 millions per second.

The applications of oscillographs based on the use of cathode rays are manifold, especially in the field of radiotechnics, but a description of these would fall outside the scope of this book.

Fig. 28 shows the oscillograph of the Western Electric Company, and in the figure there will be seen the two pairs of plates which produce the deflections of the cathode beam ; this beam strikes the layer of fluorescent material deposited on the upper part of the bulb (inside the glass), this material being composed of a mixture of calcium tungstate and zinc silicate ; the paths traced out by the cathode rays can be seen very clearly and can be readily photographed.

The instrument finds four distinct fields of application :—

(a) The determination of the amplitude of a variable, such as a current, or a voltage, a vibration or a sound. For this work only one pair of plates is used.

(b) Determinations of the relations between two characteristics of the same circuit, such as between current and voltage, or between voltage and vibration. In this case each of the two quantities acts on one pair of the deflecting plates.

(c) The determination of the wave-form of a periodic quantity such as an alternating current,

voltage, sound, etc. In this case one pair of plates is acted upon by the observed quantity, while the other is acted on by a voltage which varies with the time in some known manner.

(d) The determination of frequency by comparison with a known frequency.

This valuable instrument is not, however, limited in its application to work of this kind ; for instance, it is used in physiological laboratories for studying nervous reactions.

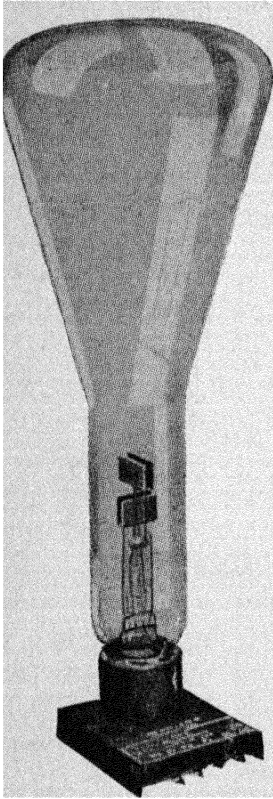

FIG. 28.

Electrons seem to be Identical in Different Phenomena

It has been seen that the study of the cathode stream in vacuum tubes has led to the discovery of the existence of elementary

electric charges which are always equal, however varied the conditions of the experiment, and which have a specific charge which is 1,840 times as great as that of the hydrogen ion ; if it be regarded as impossible that a cathode particle, which now appears as a constituent of all bodies, should contain 1,840 unit charges, it follows logically that the high value of the ratio e/m must be due to the exceedingly small mass m of the particle.

The truth of this deduction can no longer be doubted now that the elementary charge has been isolated and measured by means of marvellous experiments which will always be noteworthy in the history of physics and with which the name of Millikan is especially associated.

The study of spectral lines, as we shall see, has provided several methods for obtaining e with a high degree of precision. The existence of electrons, the atoms of electricity, has been demonstrated in different phenomena, and in all cases it is found that the value of e/m is the same ; the rays given off by radioactive substances are atoms of electricity identical with the cathode rays, but moving with a very high velocity ; incandescent solids and substances bombarded by X-rays or ultra-violet light emit electrons which are always identical in charge and in mass ; the refraction of light, and the magnetic properties of bodies also demonstrate the existence of electrons, and these, too, are always identical in their nature, no matter what the phenomena.

The electron is, then, a physical unit which is well defined and which is characterised by the invariable ratio of its charge to its mass ; it is a particle which enters into the constitution of all bodies, but it possesses a property which it was not possible to foresee when—in early times—a universal constituent of matter was imagined : it is electrified.

The Electron in Motion and its Mass

Consider an electric charge, left entirely to itself, which, after having received an impulse, continues its uniform rectilinear movement. Such a charge in motion produces a magnetic field in the same way as does every electric current. The magnetic field H produced at a point is perpendicular to the plane which

passes through this point, and through the instantaneous position of the electrified particle, and which contains the direction of motion of the charge; the value of H is equal to $(ev \sin \alpha)/r^2$ where α is the angle between the direction of motion and the line joining the particle to the point under consideration, r being the length of this line. The magnetic field thus produced is, then, determined by the instantaneous position of the particle; it follows that the system of circular lines of magnetic force, and the system of radial lines of electric force, move with the particle. This whole system of lines constitutes the electromagnetic field of the particle, a field which is rigidly bound up with its centre and which is invariable with regard to this centre as long as the velocity remains constant. The total energy of this field also remains constant as long as $v = \text{const.}$, but, in general, it depends upon v , since H varies with v . It can, moreover, be found quite easily that the energy of the magnetic field is proportional to the square of the velocity v . Now, if an external influence is exerted to reduce the velocity, the intensity of the magnetic field decreases throughout and the energy which was formerly stored up in this field is released and gives rise to a force which opposes the reduction of velocity. The charge is not brought to rest until it has done work equal to this stored-up energy; an electrified body therefore possesses, by reason of its charge, a certain inertia or supplementary mass of electromagnetic origin.

The energy of the field is $H^2/8\pi$ per unit volume in a medium of unit permeability; in the present case, therefore, the energy per unit volume is

$$\frac{1}{8\pi} \frac{e^2 v^2 \sin^2 \alpha}{r^4}$$

If it be desired, now, to calculate the total quantity of energy in the field, it is necessary to integrate the above quantity through the whole of the space surrounding the particle in motion, each element of volume having its own values of α and of r . By performing this integration it is found that the energy of the field may be expressed as $e^2 v^2 / 3a$ where a is the radius of the sphere over which the charge is assumed to be equally distributed; since,

now, this energy is equal to the kinetic energy $\frac{1}{2}mv^2$ of the particle, we have the equation :

$$\frac{1}{2}mv^2 = e^2v^2/3a.$$

This equation indicates that the particle in motion acts as a body in which there is added to the mechanical mass, another mass which is equal to $\frac{2}{3} e^2/a$;

for the energy $e^2v^2/3a$ may be thought of as if it were written in the form $\frac{1}{2}v^2\left(\frac{2}{3}e^2/a\right)$.

So far we have assumed that the particle is spherical and that the electric field around it is radial and symmetrical, *i.e.*, that the lines of force radiate from it in all directions with uniform density ; but the perfectly spherical symmetry only exists if the electron is at rest or if it moves with a velocity which is not too great, *e.g.*, below one-tenth of the velocity of light.

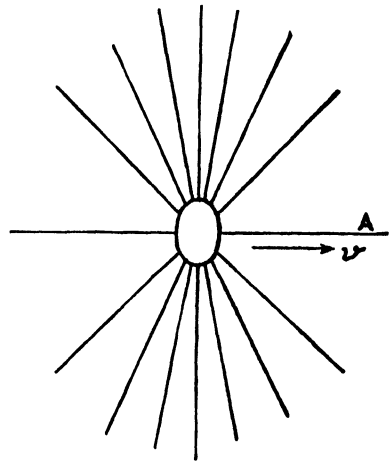

FIG. 29.—Rapidly moving electron.

If, however, the particle moves more rapidly, the electric field accompanying the electron in its movement changes its shape by reason of the reaction which it suffers from the magnetic field, this latter being produced at all points in space by the change in the electric field ; the lines of force around the electron become less dense in the direction of motion, both forward and behind, and correspondingly denser in directions perpendicular to the path of the electron (see Fig. 29) ; the force needed to produce a certain acceleration in the direction of motion is no longer the same as that which is required when the velocity is lower ; the electromagnetic mass, then, has altered.

But there is something further ; this force, if it be applied *across*

the direction of motion, *i.e.*, at right angles to the path, will produce its original amount of acceleration, because of the asymmetry of the field, and this means that the transverse mass is not equal to the longitudinal mass. To the mathematician, Max Abraham, is due this distinction between the two masses considered in two directions at right angles, but he considered the particle in motion to be incapable of deformation; Lorentz, applying his conception of a contraction, which has explained the fact that the earth's motion produces no effect on optical and electromagnetic phenomena, introduced into the calculation the flattening of the spherical particle which, owing to its velocity, became an ellipsoid, and thus he obtained for the two masses of the electron the expressions :

$$m_{longit.} = m_0/(1 - v^2/c^2)^{3/2}$$

$$m_{trans.} = m_0/(1 - v^2/c^2)^{1/2}$$

Here it is only necessary to note that the results given by modern experiments on the ratio fall into line quite naturally with Einstein's theory, and that the law of variation of mass with velocity is as valid for the material mass as for the electromagnetic mass. It will be seen why the celebrated experiments which give the variations of the ratio between the charge and the mass of the electron e/m cannot decide definitely whether the mass of the electron is entirely electromagnetic in origin or not.

Although the fact that the mass is purely electromagnetic cannot, for this reason, be established, this hypothesis is so attractive, by reason of its simplicity and on account of the deductions which can be based on it, that it is now accepted. If the electron, the universal constituent of all bodies, is reduced to a quantity of electricity without any material foundation, the conclusion follows inevitably that matter is composed entirely of electric charges and has no inertia other than that of the charges of which it is composed.

* Experiments of Kaufmann and Bucherer *

Before proceeding, we may take the opportunity of referring in some

* For a complete account of the theory of the connection between the mass and velocity of the electron, the *Handbuch der Physik*, Vol. XXIII., may be consulted.

detail to the important experiments of Kaufmann and of Bucherer which demonstrate the variation of the electronic mass with the velocity.

As we shall see better in Chap. VIII, the rays emitted from radioactive substances are identical in nature with cathode rays. Kaufmann's apparatus is shown in Fig. 30.

A particle of radium bromide was placed at *R* in a depression in a large metal plate; the rays emitted by the radium passed between two parallel plates *A* and *B* and through the small hole *P* to the photographic plate *CD*. A difference of potential maintained between the plates *A*, *B*, caused a curvature of the paths of the electrons between *R* and *P*; further, the whole apparatus was placed in a uniform magnetic field the direction of which was

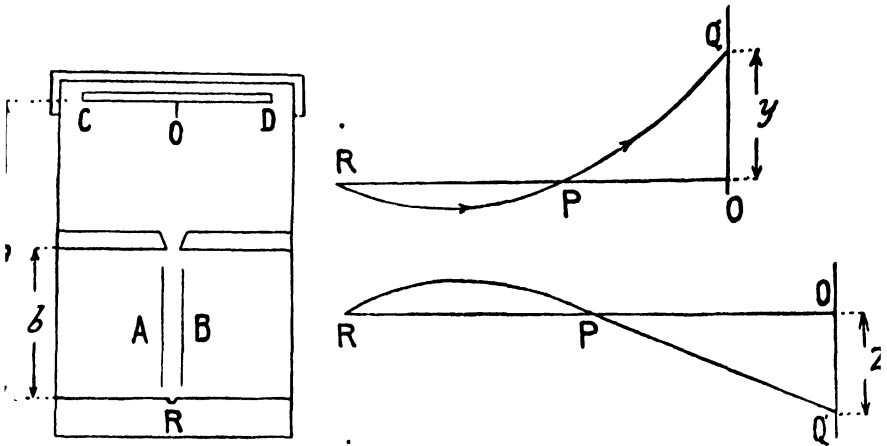

Fig. 30.—Kaufmann's experiments.

parallel to the electric field, and this caused the whole trajectory of each particle to be bent in a plane perpendicular to the other curvature.

If *r* be the radius of curvature produced by the magnetic field *H*, it is known that

$$mv/r = He \dots \dots \dots (1)$$

Further, there is a geometrical relation between the quantities *a*, *b*, *y* and *r*; using *y* to denote the final displacement, it is easy to show that

$$r^2 = \frac{1}{2} b^2 + (a^2 - ab + y^2)/4y^2 \dots \dots \dots (2)$$

Let us now turn to *z*, the final displacement produced by the electric field *F*; as this acts only along the path from *R* to *P*, the trajectory will be parabolic in the region *RP* and will then become rectilinear. It is easy to show that *z* is given by

$$z = (a - b) \cdot \frac{1}{2} b \cdot (F/mv^2) \dots \dots \dots (3)$$

There are thus three equations from which it is possible to find *e/m*, and the velocity *v* in terms of the observed values for the two quantities *y*, *z*.

The β -particles of radium bromide have velocities varying between 10^{10} and 3×10^{10} cm. per second. For each of these values of *v*, Kaufmann obtained on the photographic plate points of which the co-ordinates were *y* and *z*; from these co-ordinates it was possible to calculate the corresponding values

of v and of e/m . In this way it can be shown that when v is large e/m decreases and that it does so in accordance with the law

$$e/m = (e/m_0)\sqrt{1 - v^2/c^2}$$

where c is the velocity of light, and e/m_0 is the value of e/m when v/c is small.

Bucherer's apparatus (1908) is shown in Fig. 31. AB and CD are two circular metal plates (16 cm. diameter), separated by a fraction of a millimetre. A particle of radium fluoride was placed at the centre R , and the β -rays emitted radially from this material impinged on a photographic film PP' concentric with the discs; the whole system was enclosed in a metal box in which a high vacuum was maintained. An electric field F was produced between the discs, and there was a uniform magnetic field H parallel to them. Owing to the closeness of the discs to each other, the electrons could not reach the film unless the effects of the two fields F and H neutralised each other, and this occurred when $Fv = Hev \sin \theta$, where θ is the angle between a β -ray and the magnetic field H . Bucherer made $F/H = \frac{1}{2}c$ in many of his experiments, so that $v/c = 1/2 \sin \theta$. If $v = c$ the angle θ can only be 30° or 150° , and since v cannot be greater than the velocity of light, no ray can reach the film unless it be emitted in the zone lying between 30° and 150° , and Bucherer verified that this was precisely what occurred.

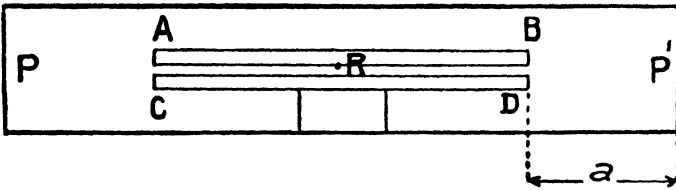

FIG. 31.—Bucherer's experiments.

We have already seen how to calculate the deviation suffered by the rays which just emerge from the discs and reach the photographic film which registers their arrival. For a given velocity v and for a given angle θ , the force acting on the electron is $H.e.v$, and the acceleration is therefore $H.e.v \sin \theta/m$. Since this latter acts for the time a/v , the final deflection is equal to

$$\frac{1}{2} a^2 H e \sin \theta / m v.$$

In this way Bucherer, by using the known value of this deviation in combination with the value of v given by the formula $v = F/H \sin \theta$, could obtain from the curve traced on the photographic film the various values of v and their relationship to the corresponding values of e/m .

From his experiments he found that the quantity $e/m\sqrt{1 - v^2/c^2}$ was constant and equal to the value of e/m appropriate to slow cathode rays; this showed that the mass m varied according to the relationship

$$m = m_0 / \sqrt{1 - v^2/c^2}.$$

The electrons in their movement then, have a mass which varies with their velocity; the vectorial equation which connects the force F with the mass is no longer that of the classical mechanics, but must be replaced by another, viz.,

$$m \frac{dV}{dt} = F \quad (V \text{ is the vectorial velocity}),$$

and hence

$$m_0 \frac{d}{dt} \frac{V}{\sqrt{1 - v^2/c^2}} = F$$

or, in shorter form,

$$\frac{d}{dt}(m\mathbf{V}) = \mathbf{F}.$$

Other important experiments having for their object to find the way in which e/m varied with the velocity were carried out by Guye and Lavanchy * in 1915, using the simultaneous action of a magnetic and an electric field : two thousand deviations, corresponding to velocities lying between $0.22c$ and $0.49c$ were measured, and the experimental points, when plotted on a diagram, were found to lie closely about the curve having the formula

$$m/m_0 = 1/\sqrt{1 - v^2/c^2}.$$

Radius of the Electron

We know that electricity possesses inertia ; an electron, therefore, by reason of its charge, must have a certain mass which, by the principle of equivalence (due to Einstein) coincides with its gravitational mass. Now the simplest hypothesis and the one which naturally suggests itself is—as has been said already—that the whole of the mass of the electron is due to the existence of the charge and is of electromagnetic origin. We have already found that the kinetic energy of the electron of radius a moving with a velocity v is $\frac{1}{2}v^2\left(\frac{2}{3}e^2/a\right)$. This expression, when compared with the kinetic energy $\frac{1}{2}Mv^2$ of a material mass M , shows that the electron behaves as if it had energy corresponding to the mass $\frac{2}{3}e^2/a$. If the variation of the mass at high velocities be left out of consideration the value at relatively low velocities (and at rest) gives a ready means of determining the radius of the electron by the use of the expression $m = \frac{2}{3}e^2/a$, which—we may point out once again—is based on the assumption that the electron is a spherical shell.

The charge e is known to be 1.59×10^{-20} electromagnetic units. † The mass m is known to be $1/1845$ the mass of the atom of hydrogen

* C. E. Guye and Ch. Lavanchy, *Arch. des Sciences Phys. et Nat.*, Vol. 42, pp. 286, 353 and 441, 1916.

† It may be noted that 3×10^{10} electrostatic units equal one electromagnetic unit, and this latter is equal to 10 coulombs.

the value of which is 1.66×10^{-24} gram. There are thus sufficient data to calculate the radius a of the electron and from the equation just given it follows that the

$$\text{Radius of the electron} = 1.8 \times 10^{-13} \text{ cm.}$$

The electron and the atom, then, are particles of quite different orders of magnitude ; we have seen, in fact, in the kinetic theory of gases, that the atom of any element has a radius of the order of 10^{-8} cm. ; this is 50,000 times as great as the radius of the electron ; the ratio is, within a little, the same as the ratio which the radius of the earth bears to its distance from the sun. It must be remarked, however, that the *spherical electron*, with the radius assumed above, is a pure supposition based on the hypothesis originally made ; at present, however, it seems less necessary to consider the spherical electron with a fixed radius, since modern tendencies seem to lead to the conclusion—as we shall see in what follows—that the electromagnetic theory is no longer applicable to systems of atomic dimensions and therefore still less to electrons which are constituent parts of atoms ; the structure of the electron is certainly one of the mysteries of contemporary physics.

The Electrons can be Seen, Heard and Measured

If a radioactive substance, which—as will be explained more fully later—emits electrons having high velocities, be placed close to a screen covered with zinc sulphide, and if this screen be observed through a lens, the eye can follow the impact of the individual electrons if these are emitted at a sufficiently slow rate so that they strike the screen in limited numbers ; it is this scintillation phenomenon which has been so extensively used by Rutherford. Instead of seeing the electrons, however, it is possible to detect them by means of an audible effect ; for this purpose all that is necessary is to arrange an electric circuit connected with an ordinary telephone by means of a valve amplifier similar to those used in radiotelephony ; the circuit is interrupted by including in it a cylindrical ionisation chamber open at the top. The walls of this chamber are connected to one end of the circuit while the other end is a metallic point which is separated from the

cylinder. Thus under normal conditions no current passes along the circuit and the telephone is silent. When a radioactive substance is brought close to the chamber, and an electron emitted from this substance enters the cylinder, an instantaneous current passes along the circuit and the sound of a blow is heard in the telephone; this is due to the fact that the air in the ionisation chamber is rendered conducting for an instant and the voltage between the walls and the point thereupon causes a discharge to pass between them.

Finally, the individual charge of the electrons has been measured by Millikan in his celebrated experiments, as we shall explain shortly.

First of all, however, it is necessary to explain the nature of the ions.

Ions

After giving a description of the nature of the electron, that universal constituent of nature, it is necessary to refer to the ion, that particle which, as its very name indicates, is cast for the rôle of a "traveller." Under certain conditions the atom, a complex system which is electrically neutral, may lose one or more of its electrons or may acquire one or more additional electrons; it is then said to become an ion. Everyone knows the celebrated theory—proposed in 1887 by Svante Arrhenius, the genial physicist of Stockholm*—concerning the electrolytic dissociation of acids, bases and salts in solution; when potassium chloride is in solution, there are present the two ions, that of potassium which has lost an electron, and that of chlorine which has captured this electron.

In the case of a bivalent metal, such as barium, two electrons are given up.

The passage of a current through a gas is, in some respects, strikingly analogous to the electrolysis of a solution, and it is attributed to the presence of ions (negative and positive) the formation of which has been brought about by the activity of certain ionising agents.

* Died at the end of 1927. *photoelectrons*

Under normal conditions a dust-free gas is an excellent insulator, and an electrified sphere suspended in the gas by means of a non-conducting thread (*e.g.*, silk) retains its charge almost indefinitely. Similarly, if two metal plates be placed in the gas, no current passes between them when they are connected to a source of potential.

Gases, however, become conductors and acquire the property of discharging electrified bodies, if they are subjected to the influence of certain agents, *viz.*, ultra-violet or luminous radiation, X-rays, cathode rays, rays emitted from radioactive bodies, the presence of incandescent solids, etc.

Under the action of these various agents the gas becomes ionised, since a certain number of the molecules have an electron removed from them by the external energy brought into play, and these molecules consequently become electrically positive; the electrons thus detached, after a short period of freedom, become attached to a neutral molecule and make it negative; thus the gas contains electrified molecules of opposite signs, one kind having the charge of an electron, the other a charge of equal magnitude but opposite in sign: these are *ions*. It is now easy to visualise the mechanism by which electricity is transferred in an ionised gas. In an electric field the ions move with a velocity proportional to the intensity of the field, and between two plates at different potentials there is set up a double stream of ions, each stream consisting of ions of the same sign which travel on to give up their charge to the plate of opposite sign. It is thus easy to imagine how an electrified body cannot retain its charge in an ionised gas, for if the body be supposed to be positively charged, it will attract negative ions, and these will slowly neutralise its charge.

If the gas between a pair of plates be acted upon by an ionising agent, such as a beam of X-rays, the current passing through this gas—air for example—increases in intensity more and more

and finally reaches a sensibly constant value (see Fig. 32)

many cells be added to the battery of accumulators which

the difference of potential between the plates; the

the current cannot exceed that value which

corresponds to the number of ions produced in unit time by the action of the X-rays.

The intensity of the *saturation current* is, then, equal to the quantity of electricity liberated in each second by the ionising agent, and may serve as a measure of the activity of this agent. It is particularly to be noted that, in apparent contradiction of Ohm's law, the intensity of the saturation current increases in proportion to the distance between the electrodes, as Righi has shown ; the reason is immediately apparent, however, when it is

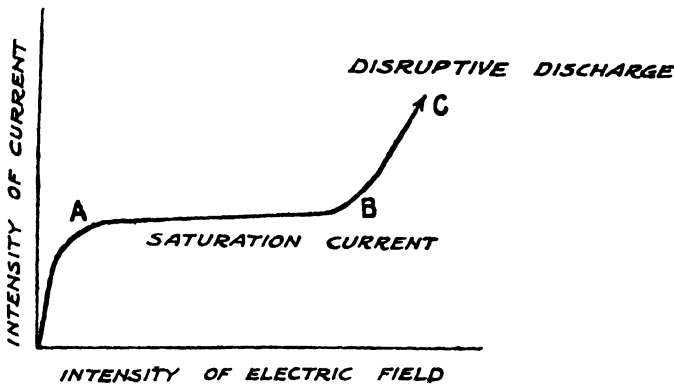

FIG. 32.

remembered that the number of ions produced per second increases with the volume of the gas subjected to the ionising agent.

This number of ions, produced in a gas by the action of a given ionising agent, has been measured and is known to be very small compared with the total number of molecules ; for instance, an intense beam of X-rays produces some 10^5 per cubic cm., while the number of molecules present is of the order of 10^{20} . The *mobility* of the gaseous ions has also been measured. This quantity is defined as the velocity which the ions acquire in a unit electric field, *i.e.*, one in which the potential fall is 1 volt per cm. This mobility varies according to the nature of the gas ; for hydrogen at a temperature of 15° and at atmospheric pressure the mobility is about 7 cm. per second, for carbon dioxide it is about 1 cm. per second.

When X-rays pass through a gas, they liberate *photoelectrons*

(as we shall see in Vol. II, Chap. V), and these are the cause of the ionisation.

The mechanism of ionisation is as follows : the photoelectrons, liberated at high velocities, gradually lose their kinetic energy by disrupting the molecules that they successively encounter, thus forming pairs of ions, until the energy of an electron has become so small that it is absorbed either by a hitherto neutral molecule or by a positive ion, which thus becomes neutralised.

All this was demonstrated by C. T. R. Wilson * in 1911 and 1912, using his celebrated *cloud apparatus*. We shall describe this on

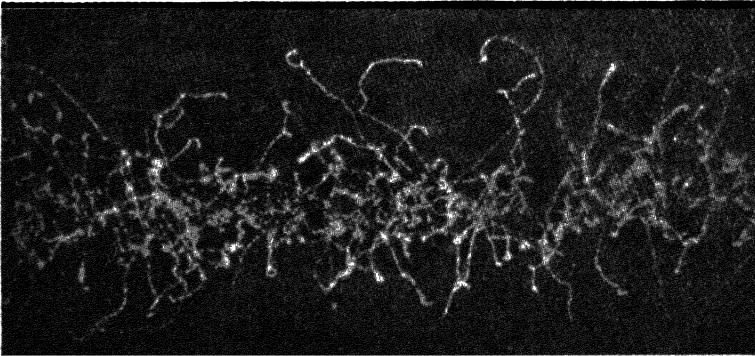

FIG. 33.

p. 317 ; in these experiments of Wilson the cloud of water droplets was photographed at the instant of its formation in an expansion chamber with transparent walls ; since the ions produced by the X-rays falling on the chamber are centres upon which the droplets in the cloud are formed, the paths of the ionising electrons are shown up perfectly. The track followed by each such electron is indicated by droplets of water which appear in the photograph.

Fig. 33 is a photograph of the numerous trajectories of the electrons produced in a gas by X-rays.

Original Determinations of the Electric Charge of the Ions

We may now proceed to explain the methods by which it has

* *Roy. Soc. Proc.*, 85, p. 285, 1911 ; 87, p. 277, 1912.

been possible to obtain a direct measurement of the elementary electric charge, *i.e.*, the charge of the electron.

These methods are of two kinds ; the first originated in the work of Townsend (1897) and J. J. Thomson (1898), was employed by H. A. Wilson (1903), and was carried to a high degree of precision by Millikan.

The method devised by Schottky is based on a totally different principle, and we shall describe it later (p. 195) after having considered the thermionic effect.

If a vapour be diffused throughout a mass of gas, *e.g.*, air, and if the temperature be then lowered, this vapour, if it was originally close to the dew-point, condenses and forms a cloud, *i.e.*, a collection of drops which are visible to the eye.

This is a well-known fact in elementary physics. Actually, however, matters are not quite so simple ; if the gas containing the vapour be rendered perfectly dust-free, as, for instance, by passing it through a filter of wadding, it may be cooled considerably below the point of saturation without any condensation taking place ; in other words, the vapour remains supersaturated. We may trespass on theoretical ground which is completely covered elsewhere, and simply state that the presence of dust particles, acting as nuclei for the formation of liquid drops, promotes condensation. The same thing occurs in the case of any ions which may be found in air or, in general, in a gas containing a saturated vapour. If this be supersaturated, either by lowering the temperature or by allowing it to expand suddenly, each ion becomes the centre of a group of molecules which form a nucleus capable of starting the formation of a drop.

Such ions exist and drops are formed in this way : each drop is electrified and takes the charge of the nucleus around which it is formed. Ions are, of course, just as invisible as neutral molecules ; but when water is condensed on them, the droplets can be seen, and thus the ions may be said to be rendered *visible*. By means of this well-known method, devised by C. T. R. Wilson (1897), the cloud produced by the passage of a narrow beam of X-rays in a supersaturated atmosphere of water-vapour may be photographed ; a mass of moist air, contained in a glass-walled vessel, is suddenly

expanded and at the same time it is subjected to the action of the ionising agent; an instantaneous photograph is then taken immediately after the expansion.

To Townsend and to Thomson (1897 and 1898) are due (as has been said already) the earliest methods of determining the charge e of the gaseous ions; although these methods are important from the historical standpoint, we cannot describe them here, but can only devote a few lines to H. A. Wilson's method.*

A and B (Fig. 34) are two metal plates forming the upper and lower walls of a glass vessel into which air, saturated with water

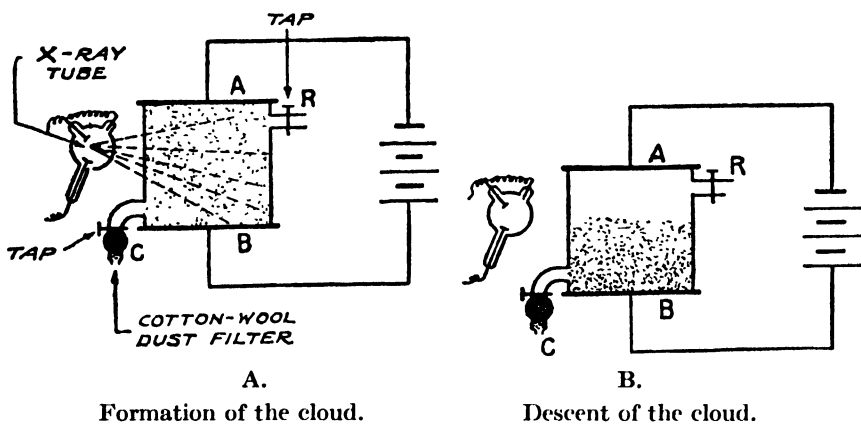

FIG. 34.

vapour, flows through a filter of cotton-wool C, so that all dust is removed before the air reaches the vessel.

(In the original experiments the plates were 3.5 cm. in diameter and were 4 to 10 mm. apart. The difference of potential between them was 2,000 volts.)

This air is slowly compressed and is allowed to take up the temperature of the laboratory; then by opening the side tap R, it is put into communication with the external atmosphere for an instant; the compressed gas suddenly expands, and in so doing is cooled.

When no ionisation has taken place, the gas remains perfectly clear under these conditions; but if, by means of a beam of

* *Phil. Mag.*, 5, p. 429, 1903.

X-rays, the gas is ionised, each ion becomes a condensation nucleus and a cloud is formed and slowly descends inside the vessel. The rate of fall is measured when the cloud falls solely under the action of gravity and again when it is acted upon by the electric field produced between the plates A and B. The ratio between the two velocities v_1 and v_2 is then the same as the ratio between the forces acting on the same droplet having a charge e . These forces are (i.) mg (mass \times acceleration) when no electric force is acting, and (ii.) $mg + He$ when the field H is set up. The following simple equation, therefore, gives the value of e :

$$v_1/v_2 = mg/(mg + He) \quad . \quad . \quad . \quad . \quad . \quad (1)$$

All the quantities in this equation are known except e , for the mass m of a droplet can be found from the formula due to Stokes (1850) which gives the velocity of fall of a small spherical particle under its own weight, when it is in a fluid of which the viscosity is η .

Thus

$$v_1 = 2ga^2d/9\eta$$

where d = the density of the droplet.

η = the viscosity of air.

g = the acceleration due to gravity.

v_1 = velocity of fall of the droplet.

This expression gives the radius a of the drop, and therefore its mass.

For air, η is known to be 0.0001824; the density of the drops of water is also known. Once the mass m is known, e can be found from (1). Actually, under the action of the electric field, the charged cloud subdivides into two or three clouds with different velocities. When equation (1) is applied to the velocities of these different clouds, each regarded as being composed of uniform droplets, the values of e obtained are roughly in the ratio 1 : 2 : 3.

This proves that there are droplets with more than one unit charge. The value found for e in the case of the cloud for which this quantity has the lowest value varies between 2×10^{-10} and 4.44×10^{-10} electrostatic units.

The precision of the method, therefore, is low. Other experiments (1910) carried out by different physicists on droplets of alcohol give $e = 4 \times 10^{-10}$. Thus the individual charge, the

atom of electricity, unique and indivisible, has been isolated, and its true value has been determined.

It will be understood that it is most important that this value should be known exactly, for, as will be seen later, the electronic charge enters into a large number of different phenomena which, from a quantitative point of view, therefore, depend on a precise knowledge of e . If e is known exactly, we can deduce the values of the other quantities which appear, with the electronic charge, in the formulæ arising out of these phenomena. This provides a check on these formulæ, or rather on the phenomena which they describe symbolically, and makes it possible to determine any one of the quantities referred to if the value of e be established with certainty.

Thus, for example, in electrolysis the charge carried by a gramme-atom of hydrogen, chlorine, silver, etc., is known to be 96,494 coulombs; if N be Avogadro's number, *i.e.*, the number of atoms involved in the transport of this quantity of electricity, we have the following equation, which has already occurred in a previous chapter :

$$Ne = 96,494 \text{ coulombs,}$$

and if the value of e is found by direct measurement to be 4.77×10^{-10} electrostatic units, it follows that N is 60.6×10^{22} ; if, however, it be considered that Avogadro's number is the more exactly known quantity—being the mean of values given by various phenomena—this equation will give the electronic charge which thus becomes the deduced quantity.

It is Robert Andrews Millikan, professor of modern physics at the University of Chicago, director of the laboratory at Pasadena in California, to whom is due the direct measurement of the electronic charge, as we shall now explain.

Millikan's Experiments.—The Study of Elementary Electric Charges which proves the Atomic Structure of Electricity

In 1908 Millikan, following Wilson, repeated, with some refinements, the experiments that have been described above; he considered that one source of uncertainty was the evaporation of the droplets during the period of observation and the probable

non-uniformity of the small spheres ; further, Stokes' law was applied to a cloud of particles, whereas it was actually established for a single sphere at an infinite distance from every other sphere and from any wall.

The first experiments, which for lack of space will not be described here, led him in 1913 to devise the *method of droplets in equilibrium*, composed of non-volatile substances, *e.g.*, oil and mercury. By this method he successfully overcame the difficulties just described and succeeded in isolating and measuring the

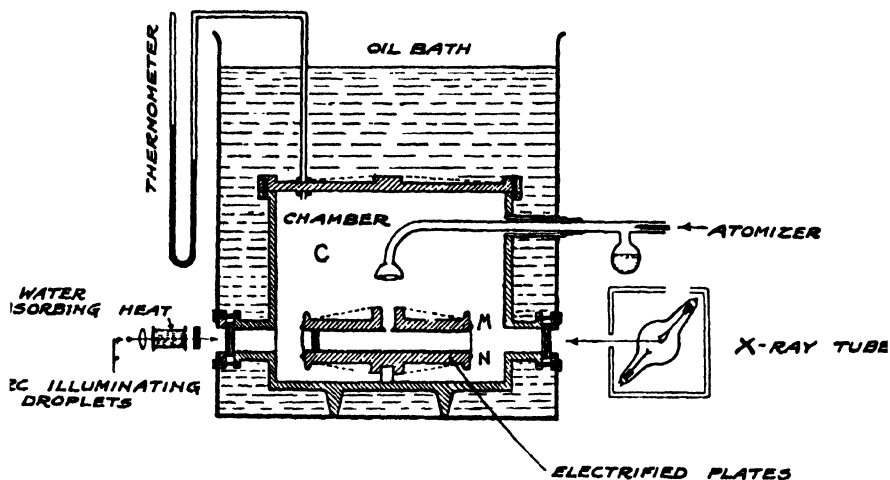

FIG. 35.

ultimate particle, or atom, of electricity, thus providing a definite proof of the atomic structure of electricity.

He constructed the apparatus shown in Fig. 35.*

An ordinary atomiser discharged a cloud of oil into the chamber C ; the air blown in with the oil was purified by passing it through glass wool. The droplets of oil, which had a radius of the order of a thousandth of a millimetre, descended slowly in the chamber C, and every now and then one happened to pass through a minute pinhole in the middle of the circular plate M which, with N, acted as an air condenser. The two plates were held together by three ebonite rods.

* *Phys. Rev.*, 2, p. 122, 1913.

The distance between the plates was 16 mm. and a potential of 10,000 volts could be short-circuited so as to destroy the electric field. An intense beam of light which passed through two opposite windows in the ebonite, showed up the droplets after they had passed through the pinhole and as long as they remained in the observation chamber.

When a droplet of oil was viewed through a third window by means of a telescope, it appeared like a bright star on a dark background.

The droplets were generally highly charged because of the friction which occurred in the formation of the cloud and one was followed with the telescope both while falling under its own weight and during its ascent under the action of the electric field. It was easy, then, to follow the movements of the same droplet for several hours, without losing sight of it, allowing it to descend, then causing it to rise, and so on. Since a droplet composed of a non-volatile material remains unchanged, its natural velocity of descent always returns to the same constant value v , and, similarly, the upward motion is always carried out with a constant velocity provided the charge and the strength of the field are the same. In the course of a prolonged series of observations it may happen that this upward velocity jumps suddenly from v_2 to v_2' , either greater or less; the charge has varied owing to the drop having captured another ion.

This discontinuous variation occurs more frequently if the gas in which the droplet is moving be subjected to an ionising radiation. It is natural, then, to attribute the change in the charge to the fact that an ion has been absorbed. For instance, with a difference of potential of 5,000 volts between the two plates M and N , Millikan observed that the distance between two lines on the graticule, corresponding to an actual height of 5.2 mm., was covered in 12.5 secs. during an ascent. A second ascent was made in 22 secs., another in 34.8 secs., another in 84 secs.; later a time of about 22 secs. occurred again, then one of 34.6 secs., etc. How is it possible to establish from this the identity of the single charges which have been individually absorbed?

Consider the relation between the charge, the field and the velocities v and v_2 corresponding respectively to the natural fall in the absence of the electric field, and to the fall when this field is acting. The following relation holds :

$$v/v_2 = mg/(Fe - mg) ;$$

v_2 is negative when the droplet rises.

This gives, for two charges e and e' , corresponding to the velocities v_2 and v_2' ,

$$e - e' = (mg/Fv) (v_2' - v_2).$$

Thus, if it is a fact that there is a minimum charge of which all the charges assumed by the droplet are larger or smaller multiples, the *differences* ($v_2' - v_2$) should correspond to a series of numbers which are exact multiples of their smallest member, or else all equal ; for (mg/Fv) is a constant.

Actually in his experiments Millikan found, for example, a velocity of $\frac{0.5222 \text{ cm.}}{12.4500 \text{ sec.}} = 0.04196 \text{ cm. per sec.}$ and then other velocities of

0.04196 cm. per sec.

0.02390 „ „ „

0.01505 „ „ „

0.006144 „ „ „

0.01505 „ „ „ and so on, so that the differences had the values of :—

0.01806 cm. per sec.

0.00885 „ „ „

0.00891 „ „ „

0.01759 „ „ „

It will be seen that these differences are as 2 : 1 : 1 : 2 and they express, when multiplied by a constant, the differences ($e - e'$) between the different charges carried by the droplet.

Other relationships of exactly the same kind were found, without exception, in all the thousands of experiments carried out, no matter what the nature of the gas in which the droplets

were suspended, and no matter what the material of which these carriers of elementary electric charges were composed, oil, glycerine, mercury, etc.

A single droplet was observed for several hours, and the number of ions absorbed during this period was not four or five, but hundreds ; at one time it was a negative ion, at another a positive ion, but in every case the differences between the velocities were found to be always multiples of the smallest among them.

The identity of the elementary charge developed by friction with that carried by ions was also established by this experiment ; actually, as soon as the droplet has entered the field of observation and is acted upon by the electric field, it moves with a velocity which lies within the range of the velocities found as a result of the absorption of ions, and in every case this rule of whole numbers is obeyed.

There were droplets which, at the beginning of the experiment, had no charge, and which successively absorbed one, two, three and four ; others carried initially seven, eight, twenty or fifty electrons, so that it was, in fact, possible to observe and count any desired number of electrons.

The following is a table of the data relative to one of Millikan's experiments :—

Distance between plates, 16 mm.

Distance of travel, 10 mm.

Difference of potential, 5,000 volts.

Pressure of air, 75 cm.

Density of oil, 0.9199.

Viscosity of air, 1824×10^{-7} .

Radius of drop, 0.000276 cm.

Temperature, 22.8° C.

Velocity of free fall, 0.085 cm./sec.

Value found for electronic charge, 4.99×10^{-10} electrostatic units.

The granular structure of electricity is thus demonstrated in a decisive manner ; what we call an electric current is nothing but a torrent of electrons ; a current of one ampere, *i.e.*, one of

3×10^8 C.G.S. electrostatic units, carries 6×10^{19} electrons per second, *i.e.*, milliards of milliards.

Accurate Determination of the Electronic Charge (1917)

It has been seen how an examination of the different velocities of descent leads to the certain conclusion that there exists an electron, a unit charge of which all other charges are exact multiples ; but the exact determination of the magnitude of this charge depends on two equations :—

$$mg/(mg - Fe) = v_1/v_2 \quad . \quad . \quad . \quad . \quad (1)$$

$$v_1 = \frac{2}{9} \frac{ga^2}{\eta} (\delta - \rho) \quad . \quad . \quad . \quad . \quad (2)$$

- ρ = density of air.
- δ = density of the droplet.
- a = radius of the droplet.
- η = viscosity of air.

$$m = \frac{4}{3} \pi a^3 (\delta - \rho).$$

Of these two equations the second gives the radius of the sphere, and hence the mass m which appears in the first formula. So far, for the sake of simplicity, the density of air has been neglected, since it is very small compared with that of oil. In an exact determination, however, this is not permissible, so that $(\delta - \rho)$ has been put in place of ρ .

When Millikan carried out experiments on droplets of different diameters, he obtained values of the elementary charge which, instead of being absolutely constant, increased slightly according as the velocity of the droplets examined was slower ; for instance, if the value was 5.49×10^{-10} for a droplet with a velocity of 1 mm. in 10 secs., the value obtained for a droplet with five times this velocity was 5.14×10^{-10} . These differences pointed to the fact that Stokes' law was not rigorously applicable. Millikan rightly considered that the droplets were so small that their dimensions were comparable with the distances between the molecules of air, and thus the essential condition of Stokes' law, *viz.*, that the spherical particles considered were moving in

a continuous and homogeneous medium, was no longer being fulfilled. If the particle is extremely small, its diameter becomes comparable with the dimensions of the molecules themselves, and there are times at which it is moving in the space between the molecules; at such times its velocity must increase and it is therefore no longer uniform. This means that the observed velocity of fall must exceed that given by Stokes' law by an amount which is greater the smaller the particle, and the value found for e will be greater as the radius decreases. This was precisely the way in which the droplets studied were found to behave.

In order to be able to allow for this effect with certainty, Millikan first of all sought to eliminate all possibility of error due to an imperfect knowledge of the coefficient of viscosity.

Experimental work carried on for a period of two years by eminent physicists led to various determinations of the value of η ; these were based on such phenomena as, for example, the flow of air through capillary tubes, the damping of the oscillations of a pendulum, etc., and gave a mean value of 0.00018226.

This portion of the problem was thus placed beyond all doubt. To investigate the applicability of Stokes' law, some interesting experiments were carried out by Dr. H. D. Arnold of Chicago, using alloys of low melting-point.

Some Rose's metal, which melts at 82° C., was placed in a glass tube 70 cm. long and 3 cm. in diameter. The water in the upper part of the tube was kept at a temperature of 100°, while in the lower part, which was a long piece of capillary tube, the temperature was 60° C. Thus, when by means of compressed air the metal was forced out of the capillary, it issued as a cloud of very small spheres with perfectly smooth surfaces and ranging in diameter from 0.2 to 0.004 cm. By means of these spheres it was possible to determine the limit above which Stokes' law ceased to hold exactly.

The following elegant method was used by Millikan to correct the results he had obtained. If Stokes' formula needs correcting, it is because the ratio l/a between the mean free path of the molecules of air and the radius of the spheres has become

appreciable so that, as has been stated already, the sphere begins to be comparable in size with the voids between the molecules.

It is therefore safe to assume that Stokes' law, as corrected, will take the following form :

$$v_1 = \frac{2}{9} \frac{ga^2}{\eta} (\delta - \rho) \left(1 + A \frac{l}{a} \right) \quad . . . \quad (3)$$

where A is a constant. It is obvious that the term $A(l/a)$ is

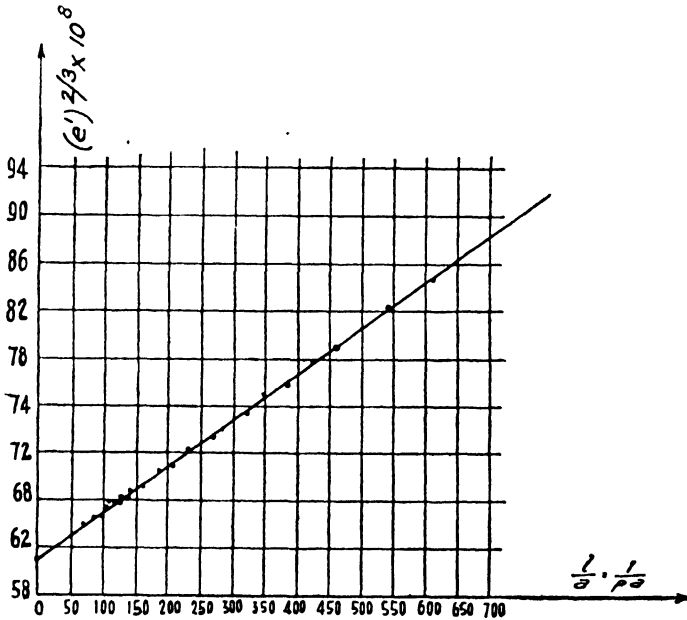

VALUE GIVEN BY GRAPH $e: 4,77 \cdot 10^{-10}$

FIG. 36.

quite small ; if this term be neglected, since l/a is of the order of one-hundredth or one-tenth, instead of the true value e of the atom of electricity we obtain a value e' which is related to e by the following equation :

$$e = e' / (1 + Al/a)^{3/2} \quad . . . \quad (4)$$

for it is easy to show that the coefficient $(1 + Al/a)$ which occurs in (3) appears in the final result, *i.e.*, the formula for e , as a correcting coefficient $(1 + Al/a)^{3/2}$.

This being so, equation (4) may be written in the form

$$e^{2/3} (1 + Al/a) = (e')^{2/3} \quad . \quad . \quad . \quad . \quad (4a)$$

and since the radius a is known approximately, it will be clear that if the results of experiments on various droplets of different radii be plotted on a graph (see Fig. 36), the values of $(e')^{2/3}$ being taken as ordinates and those of l/a as abscissæ, the points should fall on a straight line. This follows from the fact that the equation (4a) is of the form $B(1 + Dx) = y$, and this equation represents a straight line.

If the graph be drawn as described, the intercept on the axis of ordinates gives $e^{2/3}$, that is to say, the result desired. To obtain e this value must, of course, be raised to the power $3/2$.

The radius a varied, for instance, from 4×10^{-5} to 60×10^{-5} cm.

The number of electrons varied from one to a hundred per droplet; l/a had values ranging from 0.01 to 0.40.

The value of l/a could be varied either by using droplets of different radii and a constant pressure, or by using one and the same droplet with different pressures (from 4 to 76 cm. of mercury).

On the completion of his experiments—which were very quickly published throughout the world—Millikan found that $e = 4.774 \times 10^{-10}$ absolute electrostatic units, with the very small probable error of 0.005×10^{-10} .

Brownian Movement in Gases and the Charge of the Electron. M. de Broglie and Fletcher

We shall now consider another interesting method for making a direct measurement of the elementary charge.

In 1908 Maurice de Broglie * placed in a glass vessel some of the metallic powder formed by the condensation of the vapours produced by an arc, or an electric spark, struck between metallic electrodes. He observed this metallic dust through a microscope by means of a horizontal beam of light, which illuminated the particles as they executed Brownian movements.

Two metallic plates, which could be electrically charged, were arranged vertically, and the particles were enclosed in the space between them.

De Broglie observed that when a difference of potential was applied between the plates some particles moved in one direction under the influence of the electric field, while others moved in the opposite direction and the remainder were unaffected. A certain number of the particles, therefore, were charged, some positively and some negatively.

* *Comptes Rendus*, 146, pp. 624 and 1010, 1908; 148, pp. 1163, 1315 and 1806, 1909.

A year later, with the same apparatus, that is to say, a box maintained at a constant temperature, de Broglie carried out experiments on droplets of water condensed on tobacco smoke.

In his apparatus the air containing tobacco smoke was blown into the box, in the interior of which a powerful horizontal beam of light was focussed; the microscope was vertical and at right angles to the beam, while the electric field was horizontal.

The tobacco particles appeared as brilliant points of light exhibiting Brownian movements, and under the influence of the electric field F a particle having a charge e moved with a uniform velocity v given by the expression

$$F \cdot e = Kv \dots \dots \dots (1)$$

K is termed the *coefficient of resistance*. This coefficient K is actually the coefficient which occurs in Einstein's equation,

$$\overline{\Delta x^2} = 2(RT/NK)\tau \dots \dots \dots (2)$$

where N is Avogadro's number, R the gas constant, and T the temperature of the gas, while τ is the time interval within which are measured the displacements Δx , the mean square of which is represented by $\overline{\Delta x^2}$. Eliminating K from the equations given above, de Broglie obtained the charge e from a series of experiments, N being given the then accepted value of 6.5×10^{23} . In this way the value of e was found to be 4.5×10^{-10} electrostatic units, and so the first proof of the truth of Einstein's law for gases was obtained.

In 1911 Harvey Fletcher* made a noteworthy contribution to this class of experiment by combining the work of Millikan on droplets of oil (described above at considerable length) with the work on Brownian movements in gases that we have just been considering.

A charged droplet of oil between two horizontal plates giving a uniform field F is subjected to Brownian movements. If v is the velocity of free fall, and v_2 the velocity when the field F is acting, it is known that

$$e = (mg/Fv)(v + v_2),$$

and also, if K is the coefficient of resistance defined by $mg = Kv$,

$$e = (K/F)(v + v_2) \dots \dots \dots (\alpha)$$

Further, Einstein's equation is

$$\overline{\Delta x^2} = 2(RT/NK)\tau \dots \dots \dots (\beta)$$

From these two expressions (α) and (β) , which do not contain the mass of the droplet, it is possible to obtain the value of the product Ne by eliminating K , the coefficient of resistance of the medium.

The method used in practice was as follows: a droplet was held in equilibrium and the displacements due to its Brownian movement were measured; then v , the velocity of fall when no field was acting, and v_2 , that under the influence of the field, were measured.

Since forming the squares of all the measured displacements according to their direction is a laborious operation, it was avoided by relying on the known relation,† which connects the mean value of the displacements with

their mean square, viz., mean of the displacements = $\sqrt{\frac{\pi}{2} \overline{\Delta x^2}}$.

* H. Fletcher, *Le Radium*, 8, p. 279, 1911.

† This can be deduced from Gauss's law concerning the distribution of errors. It is to be noted that in forming the mean value of Δx the absolute values of this quantity are taken regardless of sign, otherwise the mean would clearly be equal to zero.

Since all the quantities F , T , v , v_2 , $\overline{\Delta x^2}$ and R are known, it is possible to find Ne , which is given by

$$Ne = \frac{4}{\pi} R T \frac{(v + v_2)r}{F \cdot \overline{\Delta x^2}} \dots \dots \dots (3)$$

By this means Ne , i.e., the charge of the gramme-ion, was obtained, and it was found that it was equal to that given by electrolysis, a phenomenon of a very different kind. This is sufficient to show that the elementary electric charge is unique, constant and universal.

Fletcher could have measured the displacements Δx of an oil particle and obtained the mean value as just described. However, he introduced another noteworthy simplification, by means of which the observation was limited to that of vertical motion only, and his method will now be explained.

Consider a droplet of oil which falls through a fixed vertical distance, viz., that between two lines on a graticule; let t be the average time of fall and v the mean velocity; if the time of fall be observed a hundred or a thousand times, it is possible to obtain the average variation Δt , which the time of fall t exhibits owing to the Brownian movement. Now it is clear that in equation (3) there appears the ratio $\tau/\overline{\Delta x^2}$ between the time interval τ and the square of the corresponding mean displacements along any selected axis, but it is evident that for this constant ratio we may substitute $t/\overline{\Delta t^2} \cdot v^2$, since in a vertical movement t is the time of observation and $v\Delta t$ is the corresponding distance. The same thing may be otherwise expressed by saying that the distance fallen, which would be vt in the absence of any Brownian movement, becomes $v(t + \Delta t)$, so that the difference is $v\Delta t$.

This expression $v\Delta t$ refers to a single Brownian displacement; the mean square is therefore $v^2\overline{\Delta t^2}$, as has been stated. It follows, then, that by means of a simple observation of times of free fall (in the absence of the electric field) it is possible to obtain the value of the ratio $r/\overline{\Delta x^2}$, which is needed before equation (3) can be used.

For example, Fletcher counted 5,900 times of fall (1914) for a single droplet of oil, and he obtained $Ne = 2.88 \times 10^{14}$ electrostatic units, which is in perfect agreement with the value 2.89×10^{14} found in electrolysis.

Other experiments were carried out by E. Weiss, Przibram, and others, on droplets of other substances of different kinds.

Anyone may easily verify that this value of 2.89×10^{14} is the product of Avogadro's number $N = 60.6 \times 10^{22}$ and the elementary charge $e = 4.77 \times 10^{-10}$, as so elegantly determined by Millikan.

The Mean Free Path of an Electron in a Gas—Ramsauer Effect

In Vol. II, Chap. VIII we shall find the explanation of this effect of which we shall now only give a general idea.

We may here refer to what has already been described in the kinetic theory of gases, where a simple expression was derived for the mean free path of a gas molecule, viz.

$$l = 1/\pi\sigma^2n\sqrt{2} \dots \dots \dots (*)$$

* C. Ramsauer, *Ann. der Physik*, 72, p. 345, 1923.

where n signifies the number of molecules per cubic centimetre, and σ is the diameter of a molecule, or rather, the radius of its sphere of action.

Now in the case of an electron moving in a gas, the fact that the size of the electron is only of the order of 10^{-13} cm. compared with the diameter σ which is of the order of 10^{-8} cm., enables a simplification to be made in the above formula. Further, the electron moves with a velocity which is much greater than that of the molecules on account of the principle of equipartition of energy (the mass of any molecule, it will be remembered, is at least 3,600 times as great as that of an electron); for an electron which can be regarded as a point, the sphere of action of the molecule has a radius equal to $\frac{1}{2}\sigma$. Since, as has just been explained, the molecules may be considered as being practically at rest with respect to the electrons, the formula for the free path becomes :

$$\text{Free path of the electrons } L_1 = \frac{1}{\pi n(\frac{1}{2}\sigma)^2}$$

and for the molecules :

Mean free path of the molecules

$$L = L_1 \div 4\sqrt{2}$$

since the factor $\sqrt{2}$ of formula (*) now disappears.*

Now let a stream of electrons be projected through a gas, all the electrons having approximately the same velocity which is determined by the value of the accelerating potential; the number of electrons reaching any point in the gas can be measured by means of an electrometer which indicates the charge received in unit time in a Faraday's ice-pail, and this number of electrons can be compared with that which the stream contained at its source. These are the experiments carried out by Lenard in 1903 and later by Mayer (1921), as indicated diagrammatically in Fig. 37.†

In this way it is possible to find the number (y) of electrons

* Because one of the two kinds of particles under consideration has a velocity which is very much greater than that of the other.

† H. F. Mayer, *Ann. der Physik*, 64, p. 451, 1921.

which, after collisions with the molecules of the gas, reach a point at a distance x from the source, and this may be done for any desired gas pressure.

In Fig. 37, T is a glass tube the pressure within which can be varied, F is an incandescent filament which gives off electrons, Q is a metallic screen, and between F and Q there is set up the accelerating field. S_1 is a perforated screen and x a distance variable at will. Between C and S_2 there is a retarding potential the value of which is equal to 0.95 that of the accelerating potential between F and Q ; in this way if an electron loses 5 per cent. or more of its energy through collisions which take place along its path, it will never reach C .

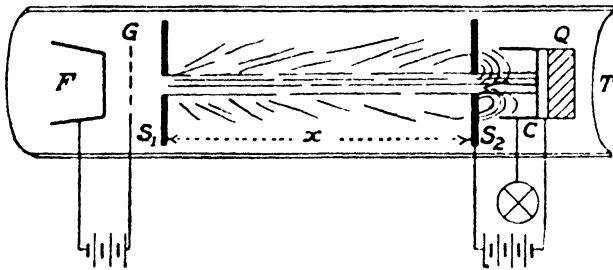

FIG. 37.

The law connecting y and x has been studied by this method, and the relation found is of the form

$$y = Ie^{-ax} = Ie^{-\alpha px},$$

where α is a constant inserted so that the pressure may appear in the formula.

The number (y) of electrons which traverse the distance x is thus given by $I = e^{-\alpha px}$, but it is also given by Ie^{-x/L_1} , where L_1 is the free path. It follows at once that

$$\alpha p = 1/L_1 = \pi (\frac{1}{2}\sigma)^2 n.$$

This equation shows that evidently, from experiments of the kind carried out by Lenard and Mayer, it is possible to deduce the total cross-section of absorbing material; actually the quantity α found in these experiments, being equal to $\pi(\frac{1}{2}\sigma)^2(n/p)$, should be constant and should give the cross-section (in sq. cm.) of

absorbing material per cubic cm. of gas at a pressure of 1 mm. and at a temperature of 0° C.

From these experiments it is possible to compare the quantity α with that obtained from the equation $\alpha p = 1 / (L \cdot 4\sqrt{2})$, where L is the free path deduced, in its turn, from viscosity measurements. In this way two different kinds of phenomena can be compared, phenomena which, on a cursory examination, would appear to be equivalent (the mean free path as found from kinetic considerations and the passage of electrons through a gas). To investigate this, Ramsauer devised the apparatus shown in Fig. 38. Here the path along which the absorption takes place and is measured is circular and not rectilinear, but this is unimportant; with great ingenuity he devised a means for producing a stream of electrons all of which had the same initial velocity, and this we shall now describe.

The electrons, which are liberated photo-electrically (by the effect of light emitted from the electric arc A), strike the metal plate P

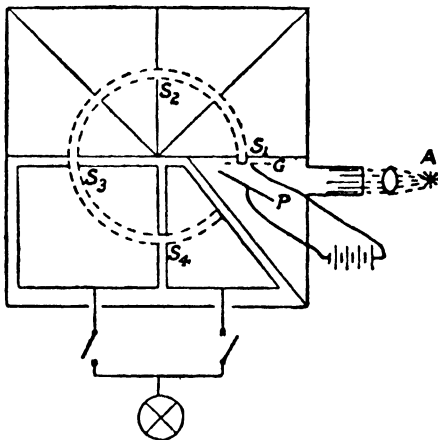

FIG. 38.

and are accelerated by the electric field between P and the metal gauze G . After passing through the slit S , they follow a circular path under the action of a magnetic field H perpendicular to the plane of the figure. By means of other slits, S_2 , S_3 , S_4 , the electrons having a certain velocity are kept in the circular stream while those which have velocities different from this, so that their paths take on different curvatures, are removed from the stream. Two insulated enclosures occupy the third and fourth quadrants of the path and surround the slits S_3 and S_4 ; thus by means of electrometers the total charge entering the two enclosures may be measured. These experiments give, for any pressure, the currents entering the third and fourth quadrants.

Let p_1 and p_2 be the pressures in two successive experiments, x_3 and x_4 the distances traversed between the screen S_1 and the slits S_3 and S_4 respectively. A simple calculation gives a in terms of the distances, the observed currents and the pressures p_1 and p_2 .

Using this method, Ramsauer was able to study the relation between the velocities (these velocities are proportional to the square roots of the accelerating potentials) and the quantity $\pi(\frac{1}{2}\sigma)^2$ which, as we have stated, gives the total cross-section of material opposed by the molecules to whatever is passing among them.

The quantity $\pi(\frac{1}{2}\sigma)^2$ is the cross-section of absorbing material (measured in sq. cm.) per cubic cm. of gas at 1 mm. pressure and—it is necessary to add—at 0° C.

The Ramsauer effect may be summarized by saying that slow electrons moving through a mass of gas (one of the rare gases) travel practically undisturbed * ; this could not be explained for several years until the theory of wave mechanics was developed, and this, as we shall see in Vol. II, Chap. VIII, treats these problems from a different point of view.

The Part played by the Electron in Conduction—Superconductivity—The Experimental Facts

The variation of the conductivity of bodies, either for heat or for electricity, under changes of temperature, pressure, purity, etc., etc., has been the subject of an enormous amount of study, both experimental and theoretical.

Several theories have been proposed in the last thirty years with the object of co-ordinating all the experimental material and bringing it into a self-consistent system, but so far the situation has always remained unsatisfactory ; the very multiplicity of the theories has been a visible sign of the prevailing uncertainty ;

* The surprising result of Ramsauer's experiments is the discovery that the cross-section of absorbing material depends on the velocity of the electrons passing through it, so that the mean free path L_1 of the electrons also depends on this velocity. Actually it is found that for very slow electrons (accelerated by a few volts only) the cross-section is much smaller than that found by the theory of viscosity (so that the free path is notably greater for such electrons than for electrons of normal velocities).

now, however, Sommerfeld and others, using Fermi's statistics as a basis, have at last been able to throw some light on this subject, and this will be seen in Vol. II, Chap. IX, when we have explained Fermi's statistical principles.

The electrical conductivities of the different elements exhibit an enormous range, as great as that covering terrestrial and stellar magnitudes. The mass of the heaviest atom is 240 times as great as that of the lightest ; the densities of the elements in the solid state, their compressibilities, and their other thermal and mechanical properties cover ranges of a hundred to one or a thousand to one ; the energy required to drag the innermost electron out of the atom covers a range of 100,000 to one in passing from the first to the last of the elements in the periodic table ; but the ratio of the electrical conductivity of sulphur to that of silver is as 1 to 10^{21} . It will be seen that a disc of sulphur 0.02 mm. thick offers more resistance to the passage of electricity than that offered by a cable of silver of the same diameter, stretching from the earth to the star α -Centauri.*

The electrical conductivities of metals, however, are confined to a small fraction of this enormous range ; it is between the metals and the non-metals, and among the latter, that the differences are so enormous.

In general, too, the resistance of a non-metallic element decreases as the temperature rises, *i.e.*, the characteristic curve (R as a function of t) bends downwards, the derivative is negative ; this usually occurs at ordinary temperatures, but not throughout the scale of temperatures which can be obtained in practice ; for some elements the curvature is concave upwards, then it ceases to bend, then passes through a minimum and finally rises.

For metals the first obvious rule is that the values of their conductivities are fairly close together ; from silver, the best conductor, to bismuth, which is at the opposite extreme, the resistance rises in the ratio 1 : 75.

The second very well-known rule is that increase of temperature causes an increase in resistance. It is commonly said that the

* K. K. Darrow, *Some Contemporary Advances in Physics* (V), *Bell System Technical J.*, 3, p. 624, 1924.

resistance is nearly proportional to the absolute temperature ; the relative increase is—to a fair approximation—equal to that of the volume of a gas under constant pressure. In other words, this means that, as a gas maintained at constant volume undergoes a pressure increase of $1/273$ for each degree rise in temperature, the same occurs as regards increase of electrical resistance ; actually this coefficient varies from 0.0058 (potassium) to 0.0063 (iron), however, and moreover the curve (R, t) is not exactly a straight line, but is better represented by means of the expression :

$$R = R_0 (1 + at + bt^2).$$

The coefficient b is usually positive, and the characteristic curve is concave upwards, but the group of metals platinum, iridium and osmium is an exception.

These and other experimental details are now well known ; but there is another phenomenon which is absolutely characteristic, viz., the superconductivity which occurs only for certain metals at the lowest temperatures, such as it has only been possible to attain within the last twenty years, owing to the advances in the technique of low temperature production. The greatest progress has been that made in the cryogenic laboratory of the University of Leyden, under the direction of Kamerlingh-Onnes,* who died in February, 1926. It was found that the temperature of 14° absolute, reached with liquid hydrogen, did not change the conductivity of metals in any striking way, but when, by the use of liquid helium, Kamerlingh-Onnes was able to get to within 5° of the absolute zero, a marvellous thing happened.

It should be noted that the temperature range within which he was able to experiment on metals (from 1.5° to 5° absolute), although it is small compared with the vast scale of temperature which can be obtained in practice, is nevertheless great when considered in terms of the distance of its lowest point from the absolute zero. This simple remark will indicate that there is here a possibility of the appearance of a discontinuity.

Kamerlingh-Onnes experimented first of all with platinum wires, and he found that down to the interval of temperature then

* *Les Supraconducteurs*, H. K. Onnes, in *Atomes et Electrons*, Rapports du Conseil de Physique Solvay, 1923, p. 165.

reached (from 1.5° to 4.8° absolute) the resistance of the wire was unaltered ; this was interpreted as meaning that the resistance of the metal, which had become very small as the temperature was lowered, now consisted solely of a term independent of temperature, due, probably, to discontinuities in the wire produced by impurities in the metal. In order to obtain a pure metal, he substituted for the platinum a sample of mercury which had been distilled many times and which he enclosed in a capillary tube so as to obtain a very fine thread which at ordinary temperatures had an appreciable resistance ; in one case, for example, this resistance was 173 ohms. When he lowered the temperature of the filament to that of liquid helium, at a certain point the *resistance vanished*.

Vanished is not any extravagant word here ; it is justified by the fact that this resistance was suddenly reduced to a millionth part of the value that it had at 4.1° .

A few other elements were found to exhibit the same astounding behaviour, viz., tin, the resistance of which vanished at 3.78° , lead (at 7.2°), and thallium (at 2.3°).

In its superconducting state lead had only $1/10^{12}$ part of its resistance at 0° C. Some years after the time of this sensational discovery, announced by Kamerlingh-Onnes at the Solvay Congress held at Brussels in April, 1921, one of his collaborators, Professor A. Tuyn, experimenting to find out whether any other elements became superconducting, found that indium also showed a discontinuity of electrical resistance at a temperature of 3.41° absolute.

Other elements, however (gold, cadmium, platinum, copper and iron), were found not to become superconducting at any temperatures that could be reached. In the neighbourhood of the absolute zero each of these metals has a constant resistance which is independent of the temperature.

It is not yet known whether any other metals exhibit superconductivity ; it may be that it occurs in the one degree interval—above the absolute zero—which has not yet been investigated.

Extraordinary things occur in a domain from which electrical resistance is absent. Thus Kamerlingh-Onnes found that in a

chamber cooled to the temperature of liquid helium, a current of 320 amps. circulated for half an hour in a lead ring without the application of any electromotive force and with a loss of only 1 per cent. of its initial value.

In another experiment, a current of 49 amps. flowed for an hour in a spiral of lead of 1,000 turns and lost less than 1 per cent. of the intensity which it had when it was started by removing the magnetic field in which the coil was originally situated.

With this rate of decrease it would take more than four days for the current to diminish to one-hundredth of its initial value, if the temperature of the lead wire were kept down to the necessary value for the whole of this time ; the resistance which was more than 700 ohms at room temperature had fallen to $1/10^8$ ohm !

Pressure has, in general, very little effect on the resistance of metals, *e.g.*, if the original pressure of one atmosphere is raised to 1,000 atmospheres, the resistance only shows a difference of a few per cent.

The technique of applying huge pressures under rigorously controlled conditions has been developed, especially by Bridgman, in the physical laboratory of the University of Harvard (U.S.A.) ; Bridgman attained 12,000 kg. per square cm. No close relation was found between the change of volume and the change of conductivity ; in general, the conductivity increased with the pressure as if the passage of electricity were facilitated by bringing the atoms closer together.

The effect of pressure over a range of 1 to 12,000 atmospheres, and over the temperature interval between 0° and 100° C., was studied for 44 pure metals by Bridgman.

In all forty-four cases except six,* the resistance is decreased by an increase in pressure ; the decrease is of the order of ten times that which would be expected from the change in the dimensions ; as might be anticipated, the conductivity increases notably in the case of the alkaline metals which are very compressible.

* Lithium, calcium, strontium, antimony, bismuth, zirconium.

The decrease of resistance for a pressure of 12,000 kg. varies from 72 per cent. for potassium to 1.1 per cent. for cobalt.

The relation between the pressure and the resistance is not linear, since the change takes place less quickly at high pressures. The case of caesium is unique in that the resistance begins to decrease rapidly, as would be expected with a very compressible alkali metal, but in the neighbourhood of 400 kg. it passes through a minimum and then increases more and more rapidly.

The table below shows some of the values obtained by Bridgman for the resistance at various pressures :

Electrical Resistance of Rubidium and Caesium

Pressure, kg./sq cm.	Relative Electrical Resistance.		
	Rubidium.		Caesium. At 0° C.
	At 0° C.	At 35° C.	
1	1.000	1.205	1.000
1,000	1.000	1.982	1.863
2,000	0.733	0.840	0.779
4,000	0.583	0.663	0.709
8,000	0.428	0.481	0.794
12,000	0.360	0.406	0.994

The thermal *conductivity* C is closely related to the electrical conductivity ; in the range of temperatures ordinarily met with, C for metals is approximately independent of temperature ; at very low temperatures C increases, but very much less rapidly than the electrical conductivity σ ; and since σ is nearly inversely proportional to the temperature, the ratio $C/\sigma T$ is approximately constant for the majority of metals over quite a wide range of temperatures. Further, *this ratio is the same for all metals* (within a variation range of 1 : 2), and this fact has been of great importance in building up theories of conduction.

In this discussion of thermal and electrical conductivities we omit all reference to the effects of mechanical tension, to the

effects of varying the temperature and pressure simultaneously, to the phenomena exhibited by a single crystal, to the behaviour of alloys and liquid metals, etc., etc. All these have been the subjects of endless experimental research.

Theories of Conductivity

It will be seen that the amount of material available on the experimental side is simply enormous.

This would be the proper place at which to describe a theory which correlated all these facts, but so far such a theory does not exist.

It might therefore be thought necessary to give a critical *résumé* of all the theoretical work which has been carried out, commencing with that of Drude ; it will, however, be sufficient to mention the contributions of Lorentz, Debye, Wien, Gruneisen, Lindemann, Borelius, Thomson, Benedicks, Waterman, Bridgman, etc., etc.

In April, 1924, a number of eminent physicists who had specialised in the subject of conductivity met at Brussels on the occasion of the fourth Solvay Congress. Among these were Kamerlingh-Onnes, Lorentz, Bridgman, Debye, Richardson and others. The proceedings of this assembly have been collected in the volume of "*Rapports et discussions du quatrième Conseil*," where the reader will find collected all the theories propounded on this subject ; but their very multiplicity is an indication that a complete physical conception of the phenomenon has not yet been developed. Since that time other theoretical contributions to the subject have been made, notably by Frenkel, Houston and Bloch, who have applied to the problem of conductivity the modern wave-mechanics. In this they have followed Sommerfeld, who, basing his work on Fermi's statistics, succeeded in 1927 in accounting, at least to a first approximation, for the phenomena of electrical and thermal conductivity as well as the other related phenomena (Hall effect, Peltier effect, Richardson effect, etc.). This we shall consider in Vol. II, Chap. IX.

Nevertheless, in view of the very great importance of the first of the theories put forward, viz., that propounded by Riecke and by Drude towards the end of the last century and subsequently

elaborated by other workers,* we are obliged to give a brief account of it, the more as this will be useful later when, in Vol. II, Chap. IX, we explain Sommerfeld's theory.

First of all it must be remembered that during the last decades of the nineteenth century, the conception formed by physicists of the passage of electricity through metallic conductors was that this was due to charged particles which were independent of the particular chemical nature of the body ; this idea was suggested by the fact that the passage of the electric current in metals did not cause any movement of material such as was observed in the case of electrolytic conductors. When, therefore, the electron, that unique and universal constituent of electricity, was discovered, it seemed natural to identify it with the carrier of electricity in metals.

This idea is supported by the thermionic and photoelectric effects ; it is well known that any metal, if heated to a sufficiently high temperature, will give off electrons. Similarly, electrons are emitted if the metal be illuminated with light of a sufficiently short wave-length (the photoelectric effect). The quantity that can be emitted is unlimited provided the metal is kept supplied by means of a conductor carrying a current.

Thus a metal is regarded as consisting of a system of atoms forming a crystal lattice, and of a cloud of electrons which are not bound to the atoms but wander irregularly in the interior of the metal just as gas molecules wander in the vessel enclosing them.

Thus what is observed in electrical conduction is the following : when a difference of potential is set up in a bar of metal, the electrons move gradually through the metal, heating it as they go, just as if the flow were similar to that of heavy particles falling with uniform velocity in a gas.

This is explained by assuming that each electron moves freely for a short distance, collides with something to which it gives up the energy it has gained during its movement in the electric field, then moves on again along a short path, and yields a further portion of energy in another collision, and so on in this way, going from point to point. Now the energy given up at each stoppage must

* Lorentz, Wien, Planck and Bohr.

be equal to the kinetic energy of the atoms in the midst of which the electrons are moving, because by the principle of the equipartition of energy, particles which are mixed together in thermal agitation possess the same mean kinetic energy no matter whether they are light or heavy.

We have spoken of a framework of atoms, but to be more exact we should have spoken of *ions*, since, if the piece of metal which we are considering is electrically neutral, and if it contains *free electrons*, the atoms must be *ionised*, either wholly or partially.

The positive ions will be capable of oscillations about their positions of equilibrium; these oscillations will be larger the higher the temperature, and their energy will form part of the thermal energy of the body.

These are the general ideas on the nature of metals upon which during the closing years of the last century various physicists such as Riecke, Drude and Lorentz have endeavoured to build up a complete theory of the thermal properties of metallic conductors.

We shall now proceed at once to treat of the problem of electrical conductivity in such a way as to obtain the mathematical expression which represents the movement of the current-carriers.

Let τ represent the time interval between two consecutive collisions, E the intensity of the electric field in the metal, e the charge of the electron, and m its mass.

If a conductor contains n electrons per unit volume, and if these move normally to the plane of the cross-section with a velocity v , then the quantity of electricity which passes through unit area of cross-section in unit time is given by $i = nve$, and this is the current density due to the movement of the electrons.

Their free path l is connected with their velocity u by the equation $\tau = l/u$, and their *mean* velocity in the direction of the field is

$$v = \frac{1}{2} (Ee/m)\tau = \frac{1}{2} (Ee/m) (l/u).$$

Thus the current density becomes $i = \frac{1}{2}(ne^2/mu)lE$, which expresses the fact that the current density is proportional to the field; this formula, in fact, is an expression of Ohm's law. The resistance of the conductor is clearly the reciprocal of the coefficient

of E in the expression written last above, and the conductivity $\sigma = \frac{1}{\text{resistance}}$ is given by $\sigma = \frac{nle^2}{2mu}$ (1)

We can now proceed to deal with the thermal conductivity C in a similar manner, and by combining the two expressions, obtain the well-known formula of Wiedemann and Franz.

To obtain an expression for C we must remember that, as the electrons move, they carry with them something which we may represent by G ,* and the amount of G which passes per second through unit cross-section of the metal bar is evidently proportional to the number n of electrons per cubic cm., to their mean free path l , to their mobility u , and to the gradient dG/dx (in the direction of the axis of the bar) of whatever is represented by G .

Put more definitely, the formula representing what takes place and giving the value of Q , the amount carried per second across

one square cm. of cross-section is $Q = \frac{1}{3} nlu (dG/dx)$.†

Considering now the transport of heat, the quantity G is $\frac{1}{2} mu^2$, the kinetic energy of the electrons, and by the principle of the equipartition of energy $\frac{1}{2} mu^2 = \frac{3}{2} (R/N)T$ since the electrons at

* G may represent momentum, kinetic energy, etc.

† So as not to interrupt the concise development of the argument we may give just an outline of the way in which this formula is derived.

If n be the number per cubic centimetre of the particles which carry G with them as they move about (G may be momentum or energy), and dn the number passing through one square centimetre per second in any direction which is inclined at an angle lying between θ and $(\theta + d\theta)$ to the direction of transport of G being considered, then $dn = \frac{1}{2} nu \cos \theta \sin \theta d\theta$, where u is the mean velocity. From this it follows that the quantity of G which is transported in unit time in this direction is given by $\frac{1}{2} nu \cos \theta \sin \theta d\theta \times l \cos \theta (dG/dx)$. Integrating over a hemisphere, *i.e.*, from $\theta = 0$ to $\theta = \pi$, the total amount of G transported is $\frac{1}{3} nul(dG/dx)$.

If G represents momentum, mu , the problem is that which arises in the study of the viscosity of gases and $dG/dx = m(du/dx) = m$, since the viscosity is defined as the resistance per unit velocity gradient, so that *viscosity* = $\frac{1}{3} mnlu$, and this is the expression which was given on p. 83 of the chapter on Kinetic Theory.

The calculation may be made more rigorous by allowing for the *law of distribution of velocities*.

a temperature T have the same kinetic energy as the molecules of a gas at the same temperature.

We may, then, put in place of G the quantity $\frac{1}{2} mu^2 = \frac{3}{2} (R/N)T$ which is appropriate to the phenomenon we are considering, and so we obtain

$$\text{Thermal conductivity } C = \frac{1}{2} nlu \frac{d}{dx} \left(\frac{R}{N} T \right).$$

Now if C be defined in such a way that $dT/dx = 1$, we obtain

$$\text{Thermal conductivity } C = \frac{1}{2} nlu \left(\frac{R}{N} \right). \quad \dots \quad (2)$$

Dividing (2) by (1) we obtain the desired relation between the two conductivities :

$$\frac{C}{\sigma} = \frac{3}{e^2} \left(\frac{R}{N} \right)^2 T.$$

R , N and e are universal constants, so that the following law may be stated : *The ratio of the thermal to the electrical conductivity of a metal is independent of the nature of the metal and is proportional to the absolute temperature.*

The first part of this proposition is precisely the law which was established empirically by Wiedemann and Franz (1853). The second part, however, is due to Lorentz.

This simple relation is undoubtedly very important; by substituting for R , e and T their numerical values we can obtain a check with experimental data obtained on various metals. If, for example, the comparison be made at 18°C ., $T = 291$; the constant R/N is 13.7×10^{-17} (absolute units); the charge of the electron in electromagnetic units is 1.59×10^{-20} .

Thus we obtain :

$$\frac{\text{Thermal conductivity}}{\text{Electrical conductivity}} = 3 \left(\frac{R}{Ne} \right)^2 T = 6.95 \times 10^{10}.$$

The ratio of the conductivities should, then, be equal to 6.95×10^{10} , and, further, the coefficient of its variation with temperature should be $1/273 = 0.0037$.

Some experimental values are :—

Metal.	Ratio of Conductivities.	Coefficient of Variation per Degree.
Copper . . .	6.71×10^{10}	0.0039
Silver . . .	6.71×10^{10}	0.0037
Gold . . .	7.09×10^{10}	0.0037
Zinc . . .	6.72×10^{10}	0.0038
Tin . . .	7.35×10^{10}	0.0034

It will readily be understood what an important part has been played by the law of Wiedemann and Franz in the development of theories of conductivity; speaking broadly, the electrical properties of metals are explained (as has been said already in p. 48).

During the last few years, however, in the light of present-day ideas regarding the constitution of the atom, this conception of "free" electrons colliding with positive ions has been shown to be completely fallacious, and a more correct picture of the movement of the electrons in a metal, either solid or liquid, has been constructed.*

It is not possible to describe this at present because we have not yet reached a sufficiently advanced stage in our work. Matters are not yet very clear, and the reader may be surprised to find that the wide range of practical applications in which thermal and electrical conductivities play their part have not yet received a complete theoretical interpretation.

Certain difficulties arose when Drude, in extending the theory

* Let us first consider a body in the gaseous state; in this case there are no free electrons, for metallic vapours are perfect insulators. The electrons which are "set free" when the vapour condenses are the electrons in the outer shells of the atoms, those electrons which determine the valency. But the process of setting these electrons free is *ionisation*, and this requires an expenditure of energy which, even in the most favourable case (caesium), amounts to 100 large calories (100,000 gramme-calories) per gramme-atom. Now the condensation of a metallic vapour is accompanied, not by an absorption, but by an evolution of energy; moreover, it is the outer electrons which determine the force of cohesion, the work corresponding to which is equal to this evolved energy. It follows that these electrons cannot really be set free, but that, on the contrary, they are bound even more firmly than when the atoms are isolated from one another.

of conductivity which we have just outlined, endeavoured to interpret it on the hypothesis of free electrons, and to account for the law of Wiedemann and Franz.

Starting from the assumption that the electrons move with the same kinetic energy as the atoms in a gas at the same temperature

(expressed in symbols as $\frac{1}{2} mu^2 = \frac{3}{2} kT$), it may be deduced from

equation (1) that
$$\sigma = \frac{1}{2} \frac{e^2}{\sqrt{3km}} \cdot \frac{nl}{\sqrt{T}}.$$

If this expression be considered in the light of the fact that the conductivity of most metals decreases with rise of temperature more rapidly than in proportion to $1/\sqrt{T}$ (actually the rate is nearer $1/T$), it will be clear that the product nl must be supposed to vary with temperature; if, as seems natural, it be supposed that the mean free path l depends on the distance between adjacent atoms, a distance which varies very little with the temperature (and, moreover, in the direction opposite to that demanded by the theory), it can only be assumed that the proportionality between σ and $1/T$ is due to the fact that the number n of free electrons (per cubic cm.) changes with T ; further, since the degree of dissociation increases with the temperature and tends towards a limiting value, there should be a temperature range within which the effect of the variation in n should predominate and then a range over which the variation of l/\sqrt{T} becomes more important than that of n . Thus the theory cannot explain a continuous increase of resistance with temperature, such as is found for metals.

There are yet other difficulties.

Drude arrived at his well-known formula :

$$\frac{\text{Thermal conductivity}}{\text{Electrical conductivity}} = 3 \left(\frac{R}{eN} \right)^2 T$$

by assuming a uniform velocity for the electrons; if, however, we follow Lorentz and allow for the fact that the distribution of velocities is really Maxwellian, the *numerical factors* which enter into the expressions for the two conductivities are different, and hence the ratio is different and in fact becomes :

Lorentz's expression

$$\frac{\text{Thermal conductivity}}{\text{Electrical conductivity}} = 2 \left(\frac{R}{eN} \right)^2 T.$$

Thus this attempt to make the theory more complete leads to a result which, instead of improving the agreement between it and the facts, introduces a disagreement, and so the wonderful accord between theory and experiment which we have just described is now destroyed.

The assumption of the principle of the equipartition of energy, which is one of the bases of Drude's theory, introduces a further difficulty by implication; if we consider that the n electrons per cubic cm. of the metal have each a mean kinetic energy equal to $\frac{3}{2} 2kT$ or a total energy equal to $\frac{3}{2} nkT$, we are forced to admit that when unit volume of the metal is heated through a temperature interval of one degree, the electrons must absorb their share to an amount $\frac{3}{2} nk$; but the specific heat of most metals is such that

it would appear that the atoms in a gramme-atom of the material take up *all* the heat supplied and none is left over for the electrons.

This is the problem referred to by physicists as that of the specific heat of the electrons. We shall see in the last chapter how Fermi's theory, applied by Sommerfeld, has overcome this uncertainty, and how further progress has been made by Houston and Bloch by means of the wave mechanics.

Thermionic Effects—General Description *

It was in 1884 that Edison described a phenomenon he had observed in lamps with incandescent carbon filaments, and this was the first notice of thermionic emission on a high vacuum. He had placed in the bulb of an incandescent lamp an auxiliary electrode half way between the two legs of the filament. Then, supplying the lamp from a source of continuous current, he connected a galvanometer across the auxiliary electrode and one

* See on this subject *The Emission of Electricity from Hot Bodies*, by O. W. Richardson; *Les phénomènes thermioniques*, by E. Bloch.

or other of the ends of the filament. Edison found that the currents passing through the galvanometer were different in the two cases, the stronger current being obtained when the galvanometer was connected to the negative end of the filament. This phenomenon, which was known as the *Edison effect*, was not explained until some years later, as a result of the work of Preece and Fleming.

Fleming realised that Edison's experiment could be made use of to rectify an alternating current, and he constructed those *valves* which are now known universally and which were the prototypes of the modern thermionic rectifiers ; he also conceived the idea of applying them to the detection of hertzian waves, which were then coming into prominence in wireless telegraphy.

Experiments on thermionic effects are made in a vacuum which may be as high as 10^{-7} mm. of mercury, and a whole technique of an entirely new kind has been developed to measure these exceedingly low pressures ; some methods are based on viscosity, others on the thermal conductivity of gases, others on the thermionic phenomenon itself.

The characteristic apparatus which is always used in studying thermionic phenomena consists of a glass bulb along the axis of which is a metal filament attached to leading-in wires fused into the glass ; surrounding the wire is a conductor designed to collect the electrons, and usually this conductor is in the form of a co-axial cylinder.

A small side tube fused to the bulb enables the latter to be evacuated or to be supplied with a gas of any kind at any desired pressure.

The current produced varies enormously with the experimental conditions ; in certain cases the current to be measured is of the order of only 10^{-13} amp., and then an electrometer is used ; when it is of the order of 10^{-9} amp. or more, a galvanometer may be used in place of the electrometer ; when the current is as high as 10^{-4} amp., direct-reading milliammeters are used. Finally there are tubes in existence which are capable of giving currents of several ampères ; the measuring instrument is then an ordinary ammeter.

We must recall that at low temperatures the particles emitted consist almost exclusively of positive ions ; at intermediate temperatures the positive ions are mixed with electrons ; at high temperatures, especially in a good vacuum, the emission consists wholly of negative particles.

We shall confine ourselves to purely electronic emission, *i.e.*, to the outflow of electrons responsible for the whole of the current in good vacua and at high temperatures. Experiments carried out by Wehnelt (*Deut. Phys. Gesell.*, Verh. 5, p. 255, 1903) and by Bestelmeyer (*Ann. d. Physik*, 35, p. 909, 1911), who measured the deviation produced by a magnetic field on a stream of the emitted particles, have shown that the ratio of charge to mass is equal to this ratio in the case of the cathode rays ; Bestelmeyer actually found that $e/m = 1.766 \times 10^7$ in electromagnetic units, thus definitely proving that the carriers of the thermionic currents are identical with the cathode particles.)

At first the metal used for thermionic experiments was platinum, then the more refractory metals such as indium (melting-point $2,300^\circ$), molybdenum ($2,535^\circ$), tantalum ($2,780^\circ$) and, above all, tungsten ($3,270^\circ$) were employed. The exact determination of the temperature of the filament is a difficult matter ; in the method most commonly adopted, the incandescent filament itself acts as a thermometer, and its temperature is obtained from a measurement of its resistance, using a Wheatstone bridge.

It is also possible to use an optical method based on the variation of the filament brightness with temperature.

The second technical problem which occurs in the study of thermionic phenomena is that of obtaining any specified gas pressure and of measuring this pressure accurately ; in particular it is absolutely necessary to be able to produce as good a vacuum as possible inside the bulb in which the hot filament is mounted, so that this may not be subjected to disturbances resulting from the presence of residual gases. High vacua may now be obtained relatively easily, thanks to the very refined apparatus now available, such as Gæde's molecular pump and the mercury vapour pump (Langmuir). But it is not sufficient to produce a vacuum ; it is necessary also to maintain it throughout

the period of the experiments, and that, too, when the filament and the bulb itself are at a high temperature; the filament is gradually raised to incandescence as the pump is operated so as to free it from occluded gases, and the glass bulb should also be heated for a certain time (of the order of an hour), at least to 300° C., so as to carry off the gases occluded on its surface. The cylinder which acts as the anode should be treated similarly.

Before concluding these brief preliminary remarks, it must be noted that the presence of gas in a bulb used in experiments on electronic emission has a great influence on the phenomena observed, for at a sufficiently high temperature the electrons may acquire, between two successive collisions with the molecules of gas present, sufficient kinetic energy to ionise the molecules it encounters; the current due to the ions thus produced is added to the electronic current, and the ions themselves may, in their turn, ionise the molecules with which they collide.

In 1903 Wehnelt had already found that the sparking potential between platinum electrodes in an evacuated tube is lowered by the presence on the cathode of a layer, however thin, of the oxides of calcium, strontium, or barium. A similar effect, though less pronounced, is produced by the oxides of magnesium, zinc, cadmium, or zirconium. A Wehnelt cathode may be prepared by taking a thin sheet of platinum and putting on it a drop of nitrate of calcium, strontium or barium; on heating the metal by passing a current through it, the salt is first evaporated to dryness and then decomposed so that the oxide is left deposited on the platinum; the thermionic emission obtained in this way is much greater than that from pure platinum.

A curious fact has been observed in connection with this. If a sheet of metal covered with oxide be heated in a good vacuum side by side with a polished sheet of metal, a very small quantity of oxide is distilled and is deposited in an exceedingly thin film on the pure metal. It is now possible to find out how the thermionic emission varies with the thickness of the oxide, and it is found that a monomolecular layer of lime is sufficient to give an emissive power practically equal to that characteristic of the oxide. This shows very strikingly the sensitiveness of thermionic phenomena

to the slightest traces of impurity on the surface of the electrodes.

It follows that by means of a cathode consisting of a strip of platinum on which there is a small patch of oxide of barium or calcium, it is possible to obtain, by passing an electric current through the strip, a fine stream of electrons; if the pressure of the gas is not too small, the stream of electrons causes it to glow, so that the path of the rays may be observed and the deflection produced by a magnetic field may be demonstrated. A tube with a Wehnelt cathode is shown in Fig. 39.

The anode *A* is a disc of aluminium and the cathode *C* a strip of aluminium 2 mm. wide. A small patch of oxide has been deposited on the centre. The leading in wires *E* and *F* are connected to the battery supplying the current necessary to heat the strip to dull redness. A

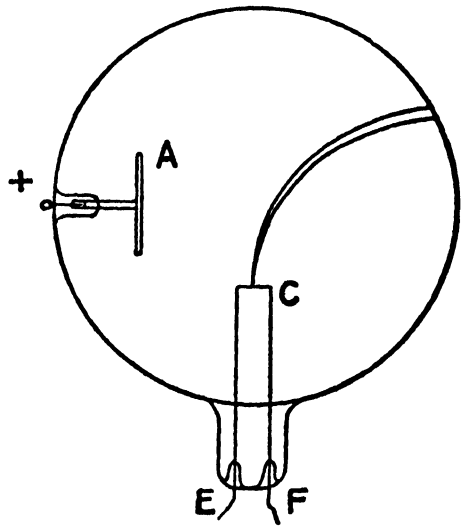

FIG. 39.

A difference of potential between *A* and *C* of some hundreds of volts produces a powerful beam of cathode rays emitted normally to the layer of oxide; by means of a magnet, the path of the beam is curved round as shown in the figure.

First Theory of Thermionic Emission

The first theory of electronic emission in high vacua was given by O. W. Richardson in 1901, and is closely connected with the electron theory of metals which was developed by Riecke, Drude, J. J. Thomson and H. A. Lorentz. It is assumed that metallic conductors contain free electrons which move in thermal agitation, just like the molecules of a gas at ordinary temperatures. These

electrons cannot leave the metal without the expenditure of a certain amount of work.

If V denotes that difference of potential between the metal and the surrounding space which is equal to this work, an electron cannot leave the metal unless its velocity component normal to the surface is at least equal to u_0 where u_0 is given by

$$\frac{1}{2}mu_0^2 = eV \dots \dots \dots (1)$$

Let us imagine the metal to be placed in an evacuated insulating enclosure at a uniform temperature: the electrons which are emitted will form an electronic gas, the constituent particles of which will gradually come into equilibrium with the "gas" inside the metal, so that as many enter the surface of the metal per second as leave it in the same time. The kinetic theory then enables us to calculate the intensity of the thermionic current per unit area of the surface. Let n be the number of free electrons in 1 cubic cm. of the metal, dn the number of these for which the velocity component normal to the surface lies between u and $(u + du)$. The kinetic theory shows that:

$$dn = n\sqrt{hm/\pi} e^{-hmu^2} du \dots \dots \dots (2)$$

where m is the mass of the electron, and

$$h = \frac{1}{2kT} = \frac{1}{2(R/N)T}$$

Since no electrons can emerge except those for which $u > u_0$ the thermionic current will be obtained by integrating the quantity $u.e.dn$ from u_0 to infinity.

$$i = \int_{u_0}^{\infty} ue dn = ne \sqrt{\frac{hm}{\pi}} \int_{u_0}^{\infty} e^{-hmu^2} u du$$

$$= aT^{1/2} e^{-b_0/T} \dots \dots \dots (3)$$

where

$$a \equiv ne\sqrt{k/2\pi m}$$

$$b_0 \equiv eV$$

Richardson's law is, therefore,

$$i = aT^{1/2} e^{-b_0/T}$$

This original theory is now no longer accepted, and we have described it in preference to others because of its historical interest; subsequently H. A. Wilson, J. J. Thomson and Richardson

himself have, by employing a line of reasoning based on the principles of thermodynamics, obtained a somewhat different expression for the thermionic current, viz. :

$$i = AT^2 e^{-b/RT} \dots \dots \dots (5)$$

The explanation of the method used for obtaining this law, which is now definitely accepted, will be deferred to Vol. II, Chap. IX, *i.e.*, after the theory of quanta has been described.

It would seem that in order to choose between formulæ (3) and (5) it might be sufficient to plot in a diagram, as a function of b_0/T the experimental values of $\{\log i - \frac{1}{2}\log T\}$, and see if this gave a straight line or, on the other hand, if a straight line was obtained when the ordinates were the values of $\{\log i - 2\log T\}$.*

Actually a straight line is obtained equally well in both cases (see, *e.g.*, *Phys. Rev.*, 21, p. 623, 1923, article by S. Dushman). The reason for this is that the exponential term is much more important than either $T^{1/2}$ or T^2 . Actually, in passing from 1,000° to 2,500° absolute, the emission of tungsten increases in the ratio 1 to 10¹¹, while the term $T^{1/2}$ only increases in the ratio 1 to 1.58 and T^2 as 1 to 6.25. The most recent and accurate work, however, confirms the value 2 rather than $\frac{1}{2}$ for the exponent.

The following table gives the values of b_0 calculated by means of formula (5) from the measurements of current at various temperatures made by Davisson and Germer on a tungsten filament :—

Absolute Temperature.	Current i .	b_0 .
1935.5	0.0934 × 10 ⁻² ampère/sq. cm.	51890
2036.0	0.3967 × 10 ⁻² " "	51860
2086.5	0.7656 × 10 ⁻² " "	51900
2131.5	1.362 × 10 ⁻² " "	51840
2158.0	1.902 × 10 ⁻² " "	51820
2204.0	3.269 × 10 ⁻² " "	51820
2235.0	4.606 × 10 ⁻² " "	51870
2280.0	7.494 × 10 ⁻² " "	51920

* For from (3) we obtain

or $\log i = \log a + \frac{1}{2} \log T - b_0/T$
 $\log i - \frac{1}{2} \log T = \text{const.} - b_0/T.$

The Saturation Curves

So far we have implicitly supposed that at the various temperatures all the electrons emitted move under the influence of the steady electric field between the anode and the cathode, and that their total number determines the strength of the current.

In fact, it might seem at first sight as if a very slight difference of potential would be sufficient to produce these effects; this, however, is not so: if the current obtained be plotted as a function of the temperature for various potential differences between the filament and the anode, the set of curves obtained is like that shown in Fig. 40 which refers to tungsten. These are Langmuir's curves.

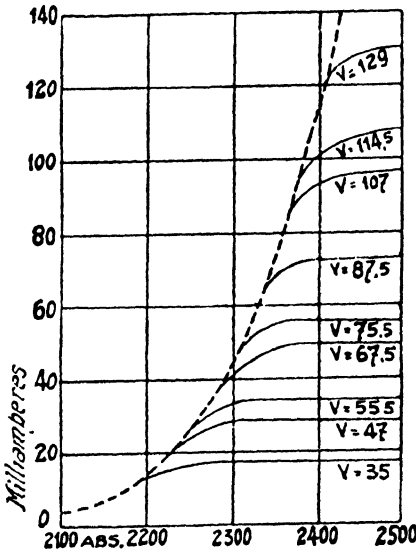

FIG. 40.

The curve shown by the broken line represents Richardson's law.

Thus, for any given voltage, after a certain temperature has been reached, the current which can be emitted *in vacuo* has a

definite constant value and is independent of the temperature. The explanation of Langmuir's curves is to be sought in the mutual repulsion of the electrons emitted from the filament; this repulsion, which is negligible when the electrons are few, becomes important when the temperature of the filament has reached such a value that the electron current is greater than 1 milliampère. There is then a negative charge of very high density in the space between the two electrodes, and this produces a repulsive field which exceeds the accelerating field; saturation becomes difficult, and after a certain value of T has been reached the space charge has a value such that the opposing field it produces is sufficient to drive back to the cathode all the electrons which are emitted from it;

after this point has been reached the current ceases to increase, however much the temperature of the filament be raised.

Thus the curves of Fig. 40 show that up to a certain point the current is independent of the voltage and varies solely with the temperature, and that, on the other hand, for a given voltage of the plate there is a high temperature region within which the current can no longer vary as T increases.

It is possible, then, to construct another diagram connecting the milliamperes with the volts for various temperatures $T_1, T_2, T_3, T_4, \dots$

If such a diagram be drawn, it will be found to consist of a family of curves similar to that of Fig. 40, for there will be a limiting curve which represents the fact that the current does not vary with the temperature (up to a certain point), but only with the plate voltage j , and likewise the curves 2, 3, 4, etc., which bend round horizontally represent the *saturation currents* at the various temperatures T_1, T_2, T_3 , etc.

It will be interesting now to investigate the mathematical formula for curve 1, and then to express the theoretical variation of the current (I_p) with change of voltage (V_p) in a diode. We may say at once that this relation is $I_p = C.V_p^{3/2}$; C is a constant which depends on the geometrical form of the diode.

Let us examine, in this connection, the particular case of an incandescent cathode consisting of an infinite plane placed parallel to a cold anode which is also an infinite plane; a uniform field is set up in the vacuum between the two electrodes, with a difference of potential V . The electrons emitted from the incandescent cathode set up a negative space charge of density ρ in the space between the plates, and this destroys the uniformity of the field; if the x -axis be taken along the normal to the two plates, with the origin of co-ordinates at the hot plate, the potential distribution will be given by Poisson's equation:

$$d^2V/dx^2 = - 4\pi\rho \quad . \quad . \quad . \quad . \quad . \quad (1)$$

Let us now find the relation which connects the current i with the difference of potential V as soon as the current has attained its limiting value. The velocity v acquired by an electron of

a is the radius of the hot filament, r is the radius of the outer cylinder.

When r is fairly large compared with a (e.g., fifteen times as great or more), β may be put equal to 1 without appreciable error. Then the formula becomes :

$$i = \frac{2\sqrt{2}}{9} \sqrt{\frac{e}{m}} \frac{V^{3/2}}{r} = 14.65 \times 10^{-6} \frac{V^{3/2}}{r}.$$

It is much easier to verify formula (5) than (4), and this has been done by S. Dushman (*Phys. Rev.*, 4, 1914, p. 121), who obtained a satisfactory check on the proportionality between the current and the $3/2$ power of the voltage.

A knowledge of the absolute value of the coefficient of proportionality gives, by means of formula (5), the value of the ratio e/m for the electron ; the value found is 1.755×10^7 electro-magnetic units, and its excellent agreement with the universally accepted value provides a useful confirmation of Langmuir's theory.

Langmuir himself has since shown that the law $i = kV^{3/2}$, which was found for a cylindrical field and for a field between two planes, holds also for a field of any form whatsoever, when the electronic emission is sufficiently intense to bring into action the mutual repulsion resulting from the space charge.

Thermionic Valves *

We will now describe quite briefly a very important application of the thermionic effect in the form of the three-electrode valve. The widespread use of these valves by thousands of amateurs makes it unnecessary to go very deeply into the principles underlying their action, and, in fact, these principles will be found described in numerous technical publications.

We shall therefore confine ourselves to giving a brief outline.

The principle of the two-electrode valve, or diode, is as follows : in a bulb exhausted to a high vacuum there are a filament f and an electrode ; when the filament is raised to incandescence by means of an electric current flowing through the external circuit of which the filament forms a part, it emits electrons, which are attracted to the electrode so long as this is at a higher potential than the filament. Otherwise no appreciable current passes. In the original types of valve devised by Fleming, the cathode was a carbon filament. Later on tungsten was used, surrounded by a copper collector. The space between the electrode and the filament is a unidirectional conductor, and it is for this reason that Fleming's device has been called a "valve," for

* Of the many books on this subject, the following may be consulted : "Les lampes à trois électrodes," by C. Gutton, 1929.

it is just like this mechanical device, in that if an electronic valve be inserted in a circuit to which is applied an alternating potential, the only current which can pass through the lamp is that which, inside the bulb, travels towards the filament, and not in the opposite direction. In fact, Fleming in 1904 used a two-electrode lamp to *rectify* alternating current. The *kenotron* is an alternating current rectifier suitable for industrial use.

The unidirectional conductivity of the two-electrode valve enables it to be used as a detector of the high-frequency oscillations employed in radio-teleggraphy. It is clear that these oscillations cannot be detected, either by a galvanometer or by a telephone diaphragm, as neither apparatus can respond to vibrations of a higher frequency than 2,000 or 3,000 periods per second.

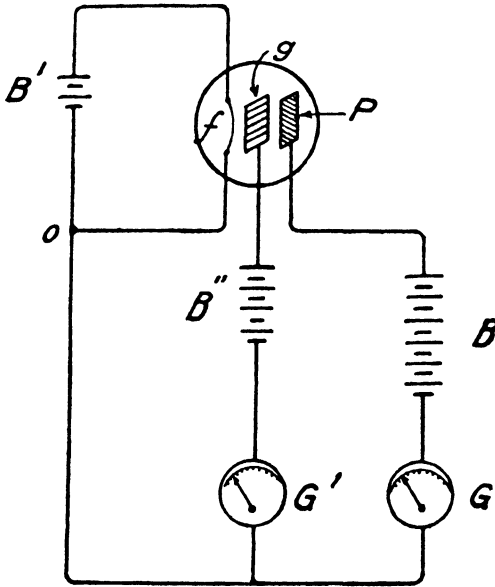

FIG. 41.

The galvanometer G measures the intensity of the electronic current passing to the plate from the filament f . The grid is connected to the filament by means of a conductor which includes the battery B'' . By varying the number of elements in this battery and the direction of their polarity it is possible to control the magnitude and the sign of the potential difference applied between the grid and the filament, and the effect can be observed by means of the galvanometer G' .

The following are the *three circuits of the triode*: the plate circuit, the grid circuit and the filament heating circuit; all three have the point O in common.

Between this point O and the grid the so-called *grid-voltage* is inserted; between O and the plate the *plate-voltage* is inserted. The end of the hot filament, which is connected to O , is the low potential end, since it is connected to the negative pole of the battery supplying the heating current.

The plate circuit does not convey any current when the grid is at a lower potential than the point O , *i.e.*, when it is connected to the negative pole of the battery B'' , for then the grid repels the electrons coming from the filament

Fleming's valve has been profoundly modified by the work of the American, Lee de Forest (1905), who introduced a third electrode into the bulb. This third electrode consists of a perforated metal sheet, and has therefore become known as the "grid"; it is placed between the filament f and the plate P (see Fig. 41).

The plate and the grid g are insulated from the filament and from each other; they are connected to leading-in wires which pass through the bulb.

The plate is connected to the filament by means of a conductor which includes the battery B , and the number and arrangement of the elements of B are changed so as to vary the sign and the value of the potential difference applied between the plate and the filament.

and prevents them from reaching the plate. If, however, the potential of the grid be raised by connecting it to the positive pole of B', it will attract the electrons, and, while a few are caught by it, the remainder will travel on

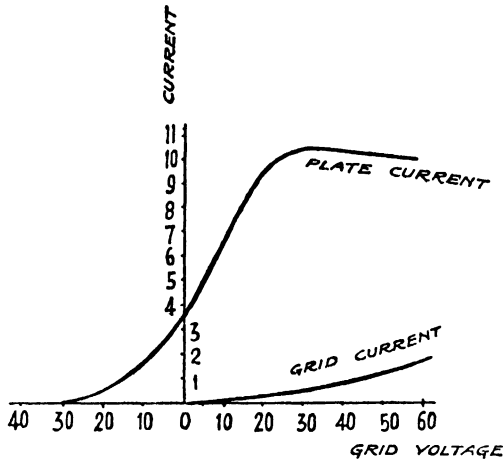

FIG. 42.

and reach the plate, and so produce a current in the plate circuit. Thus, by varying the potential of the grid, the current can be interrupted, re-started or modified.

The current in the grid circuit, however, is always very small, and may be zero if the potential of g is lower than that of the point O. A very small amount of energy is sufficient to vary the potential of g , and it is on this account that the triode forms such a sensitive and distortionless relay ; it is

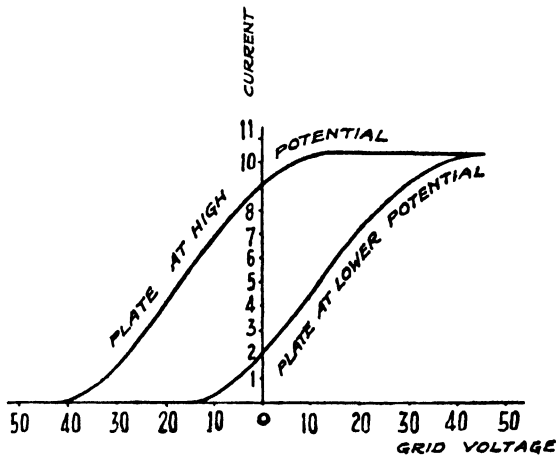

FIG. 48.

a device without mechanical parts and so has no inertia. It therefore follows without any lag variations in potential even of the highest frequency.

The practical applications of the triode have led to the study of its *characteristics*, *i.e.*, the curves which show the effect of changes of grid potential on the currents in the grid and plate circuits. Naturally the form of these curves depends on the nature of the electrodes and their distance apart, the quality of the "vacuum," the temperature of the filament, the potential of the plate, etc. Thus there is, for example, the *characteristic for constant plate potential* when the filament temperature and the difference of potential between plate and filament are kept constant (*i.e.*, the numbers of the elements in the batteries B and B' are unchanged). Under these conditions, if the grid potentials be plotted in *volts*—as abscissæ—and the plate currents as ordinates (in milliamps), the curve obtained is of the form shown in Fig. 42. The variation of the grid current (in microamps.) with change of grid potential may be studied under the same conditions.

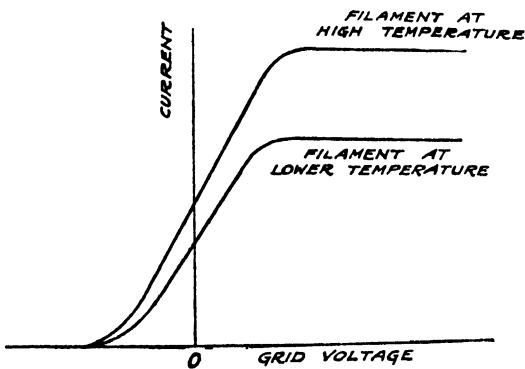

FIG. 44.

For small negative potentials of the grid the current is zero, although the plate current is several milliamps.

The curves which show the variation of the plate current with change of grid potential for different plate voltages (*e.g.*, 120 to 200 volts) are also important, and so are those for different filament temperatures. Figs. 43 and 44 give some idea of these curves.

The influence of the quality of the vacuum may also be studied.

We cannot describe, even briefly, the various types of triodes; we will simply mention that these wonderful and yet simple devices fulfil several functions at once; they act as *detectors*, as *amplifiers*, and as *oscillators* (generators of undamped oscillations). It is on account of the many functions which it can perform that the triode has the place of honour in radiotelegraphic and radiotelephonic transmission and reception, as well as in television.

There are also valves with four electrodes and others with five, but for descriptions of these and of their application we refer the reader to special books on radiotechnology.

The importance of the electronic tube has become enormous; it is now applied not only in the electrotechnical and the acoustic laboratory, but in telephony, both wireless and over lines, in radiotelegraphy, in television, in the "talking film," and in numerous other fields, both scientific and industrial.

*A further Determination of the Elementary Electric Charge

Another method based on an entirely different principle from that of Townsend, J. J. Thomson, Wilson and Millikan, was devised in 1918 by Schottky; it is based on the measurement of the amplitude of the oscillations produced in a circuit which is in

resonance with the fluctuations of current passing through a thermionic tube placed in series with it. This method was tried out in practice by Hartmann, Hull and Williams in 1925, and has given a result which does not differ sensibly (only 0.3 per cent.) from that obtained by Millikan.

The complete description of the method is somewhat complicated and we must confine ourselves to giving a general idea of it.

Let us consider a two-electrode tube in operation ; the current flowing between the filament and the plate is composed of the electrons which leave the incandescent metal. The current is not strictly constant ; it undergoes *fluctuations* which are controlled by certain laws. If the mean fluctuation of the current (the square root of the mean square) be computed, the value obtained is greater, the greater the value of i_0 , the smaller the time Δt and the larger the elementary charge, for the current is the sum of those elementary particles of electricity, e , which determine the fluctuations.

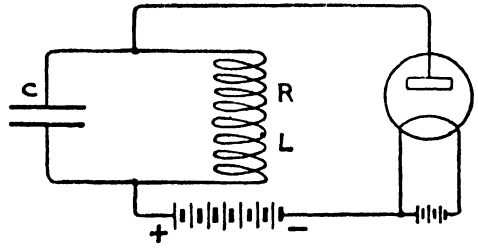

FIG. 45.

It is shown * that the amplitude $\bar{j}_{\Delta t}$ of the fluctuations in the current is given by

$$j_{\Delta t} = \sqrt{i_0 e / \Delta t} \quad . \quad . \quad . \quad . \quad . \quad (a)$$

If a thermionic tube be put in series with an oscillating circuit consisting of a resistance coil R and a self-inductance L in parallel with a capacity C, the constant portion of the current flowing through the tube, i_0 , will not affect the oscillating circuit, while the variable part will do so.

* Equation (a) is derived as follows :—

Let \bar{n} be the average number of the electrons emitted per second, and $j_{\Delta t}$ the fluctuation of the thermionic current, then

$$i_{\Delta t} = j_{\Delta t} - i_0 = \{n_{\Delta t} \cdot e / \Delta t\} - \bar{n} \cdot e$$

Also

$$\bar{j}_{\Delta t}^2 = \{e^2 / \Delta t^2\} (n_{\Delta t} - \bar{n} \cdot \Delta t)^2_{\text{mean}}$$

But from p. 121 we know that $(n_{\Delta t} - \bar{n} \cdot \Delta t)^2_{\text{mean}}$ has the value $\bar{n} \cdot \Delta t$, so that $\bar{j}_{\Delta t}^2 = \{e^2 / \Delta t^2\} \bar{n} \Delta t = \bar{n} e^2 / \Delta t$, and since $\bar{n} e = i_0$ we have $\bar{j}_{\Delta t}^2 = i_0 e / \Delta t$.

The mean square of the variations in the difference of potential across the condenser is given by

$$\overline{E^2} = Lei_0/2C^2R \quad . \quad . \quad . \quad . \quad . \quad (\beta)$$

The effect produced is thus proportional to the elementary charge.

Let us think of a mechanical analogy in order to make the matter clearer. Consider a pendulum moved from its position of equilibrium by a force proportional to the displacement (this corresponds to the condenser in what has just been described); the pendulum is damped by a resistance proportional to its velocity by immersing it in a fluid (this corresponds to R). Suppose that this pendulum is bombarded with numerous small projectiles which strike it horizontally in such a continuous stream that they keep it deflected from its vertical position; the stream consists of a large number of particles which follow one another without any rhythm, and its mean intensity is maintained at a constant value; its fluctuations, however, cause the pendulum to oscillate slightly, and the average amplitude of these fluctuations when squared is proportional to the mass of the particles which can thus be found.

Returning to our problem, we may say that it is readily possible to measure the mean square of the fluctuations of the alternating voltage by applying this to the terminals of a three-electrode valve, following the ordinary technique of wireless telegraphy; the intensity of the current so obtained is proportional to the quantity to be measured.*

ISOTOPES

Positive Rays

If we study the electric discharge in a Crookes tube with a perforated cathode, we shall notice narrow luminous bundles of rays passing through each of the holes in the cathode. These rays were discovered by Goldstein (1886), who gave them the

* For a detailed account see W. Schottky, *Annalen d. Phys.*, 57, p. 541, 1918; and 68, p. 157, 1922; A. W. Hull and N. H. Williams, *Phys. Review*, 25, p. 147, 1925.

name of canal rays (kanalstrahlen). Whilst the wall of the bulb which is in the path of the cathode rays always glows with a greenish light whatever the nature of the residual gas, the colour of the light produced by the canal rays behind the cathode depends on the nature of the residual gas in the tube ; air gives a yellowish glow, hydrogen appears a rose colour, neon glows with a bright red light, etc. These rays cause the walls of the tube to phosphoresce wherever they meet them, and they can affect a photographic film. They can be deflected by means of powerful magnetic fields, and the deflection is in the opposite sense to that exhibited by the cathode rays. Wien (1898) was the first to measure the velocity v and the specific charge E/M

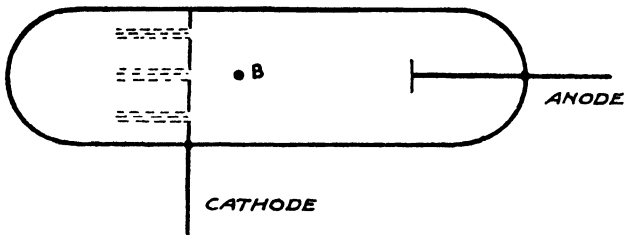

FIG. 46.

of the particles composing these canal rays, by using the combined effects of a magnetic and an electric field. The velocity, which varies according to the conditions, is only some hundreds of km. per second, *i.e.*, of a very much lower order than the velocity of the cathode rays ; further, the ratio E/M between the charge and the mass is found to be of the same order of magnitude as that found in electrolysis. These positive rays, then, differ fundamentally from the cathode rays in that they consist of positively charged particles and the mass conveying the charge is *of the order of magnitude of the atomic mass*.

Although they are not visible except behind the cathode, the positive rays originate in the space between the anode and the cathode ; in fact, a small screen placed at B in front of the cathode (see Fig. 46) stops the corresponding part of the beam.

Goldstein's canal rays are composed of the atoms and molecules of the residual gas which have lost one or more electrons ; these

atomic residues which lack electrons are consequently positively charged and so move from the anode to the cathode and through it wherever it is perforated. It will thus be seen how complex the composition of the positive rays may be as compared with the simple nature of the cathode rays, which are always identical and of one kind only.

This complexity is shown up very clearly in the ingenious and sensitive experiments devised by J. J. Thomson for measuring the charges, masses and velocities of the positive particles.

The principle is as follows : A particle in the canal rays which,

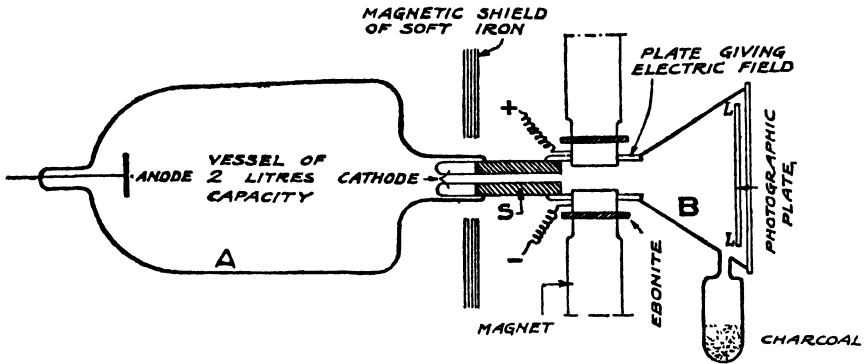

FIG. 47.—J. J. Thomson's apparatus for studying positive rays.

(The part S of the cathode is of soft iron in order to protect the rays from the magnetic field, whilst they are passing through the tube.)

if undeflected and moving in a straight line, would strike a screen placed at the end of the discharge tube, is deflected if an electric field acts on it during its flight ; further, if it is simultaneously acted upon by a magnetic field, the lines of force of which are *parallel* to those of the electric field, the particle undergoes a second deviation *perpendicular* to the first.

Thomson's apparatus consists of two compartments, A and B, separated by a very thick metal tube, which serves as the cathode and which is traversed throughout its length by a narrow hole (a tenth or a hundredth of a millimetre in diameter). In compartment A, which contains the anode, the pressure is a few hundredths of a millimetre of mercury, while in B the pressure is maintained at as low a value as possible by means of a tube

containing charcoal immersed in liquid air. The stream of positively charged atoms flowing into the anode chamber through the very narrow hole in S, forms a very fine beam which strikes a photographic plate LL placed in compartment B and is there recorded. Immediately after it has emerged from S, the beam passes through the electric field and a magnetic field parallel to it. If the charge on an atom be represented by ne (e being a unit charge), and if M be its mass and v its velocity, then it is known that the deviation x produced by the electric field is given by $x = Ane/Mv^2$ where A is a quantity which can be calculated from the dimensions of the apparatus and the strength of the field; the deviation y produced by the magnetic field is Bne/Mv where B is another known constant.

It will be seen that the two displacements x and y are not the same function of the velocity v of the particles, so that two particles which have different velocities

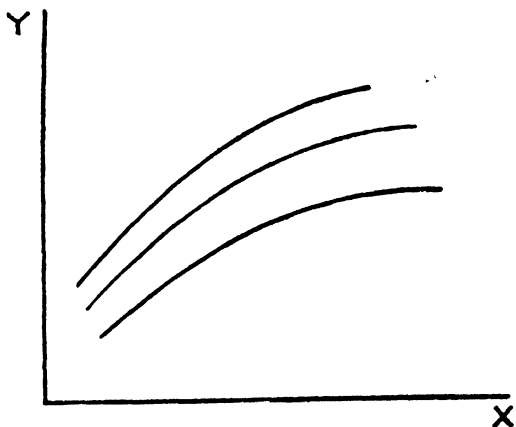

FIG. 48.

do not strike the screen at the same point, even if they have the same specific charge ne/M . On the other hand, all the particles which have the same value of ne/M strike the screen at points which lie on a curve, the equation to which can be deduced by eliminating v from the relations just given. This equation is

$$y^2 = \frac{B^2}{A} \cdot \frac{ne}{M} \cdot x$$

This curve is therefore a parabola, and if all the particles in the beam of canal rays are identical, this beam will give only a single parabola on the photographic plate. It will be clear that the particles cannot all have the same velocity, for those which

originate near the anode are accelerated by the whole potential difference between the electrodes of the discharge tube (30,000 to 40,000 volts) and so acquire the highest velocity ; those originating near the cathode are only subjected to a very small fall of potential.

This being so, if the beam of positive rays contains particles of different charges or of different masses, giving different values of the quotient M/E , each *class* of particle gives rise to a different parabola so that the photographic record shows at a glance how many kinds of particles there are in the positive stream.

It is possible, by the following method, to distinguish curves due to particles having a single charge from those produced by particles with a larger number of charges ; actually, the parabolas consist only of curves of finite length which start at a certain distance from the vertical, at a definite abscissa defined by the equation $x = A(E/M)(1/v^2)$. This gives

$$\text{kinetic energy} = \frac{1}{2} Mv^2 = AE/2x = E \cdot V$$

where V is the difference of potential between the anode and the cathode in the discharge tube. If we consider the particles carrying two elementary charges, these acquire twice as much kinetic energy in passing down the tube ; some will lose a charge whilst passing through the cathode, and since they possess double kinetic energy they will strike the plate at a distance x' which is half x .

Thus the beam of particles with charge $2E$, as it issues from the tube, consists of two groups, the particles in one group possessing twice the kinetic energy of those in the other group ; the double-charged particles will therefore strike the plate at points which are closer to the vertical, thus extending the parabola appropriate to the particles with a single charge.

As a comparison curve for the interpretation of the photographic record, the parabola corresponding to a particle of known mass (*e.g.*, an atom of oxygen or hydrogen) is taken. The principal use of Aston's ray method is for the determination of the masses of atoms or molecules. For this purpose the method of parabolas has a disadvantage, since the beam which comes from the hole in the cathode is spread out so that it gives rise to a shadow with

a penumbra surrounding it, just like that which would be produced by a beam of light coming from an extended source and passing through the hole in the cathode. Thus the lines produced cannot be sharp and fine, but are shaded off. Furthermore, the particles having the same value of e/m are distributed over a long line so that a short exposure is impracticable; two methods for concentrating all the rays corresponding to the same value of e/m have been devised, one by Dempster,* and one by Aston himself. We shall describe these on pp. 206 *et seq.*

Use of the Positive Rays as a method of Chemical Analysis— Aston's Isotopes

In the photographs, then, each parabola indicates the presence in the discharge tube of particles for which the ratio (*charge*)/(*mass*) has a specified value; thus the photograph provides a catalogue of the various kinds of atoms present in the tube; it is a *spectrum* of these atoms; just as the optical spectrum analyses the radiation within a beam of light, this photographic "spectrum" analyses the various kinds of atoms in a beam of particles. The method is very sensitive and enables the atomic weights to be determined to an accuracy of 1 part in a thousand.

Aston introduced certain known ions, such as H_2 , O_2 , CO and CO_2 , into the discharge tube so as to have a reference pattern by which to interpret the parabolas.

In 1913, Thomson and Aston made an astounding discovery when applying this method of analysis to the study of atmospheric neon; they found that this gas gave *two groups* of parabolas indicating the existence of two kinds of atoms with atomic weights respectively equal to 20 and 22; neon appeared to be a mixture of two gases. The conclusion that atmospheric neon (at. wt. 20.2) was really a mixture of two gases, after Aston had vainly sought to separate them by fractional distillation, was not followed up for several years; it was in 1919 and 1920 that Aston † published the results of his later researches which had

* A. J. Dempster, *Phys. Rev.*, 11, p. 316, 1918; 18, p. 415, 1921; 20, p. 631, 1922; 21, p. 209, 1923.

† F. W. Aston, *Phil. Mag.*, 38, p. 707, 1919; 39, p. 611, 1920; 42, p. 436, 1921; 43, p. 514, 1922 (with R. H. Fowler).

been interrupted by the war ; the principal fact was that, besides neon, other elements, when analysed by means of the positive rays, appeared as mixtures of separate components (isotopes). *A single element gave rise to a mass spectrum.*

Researches of quite a different kind in the realm of radioactivity—which we shall deal with later on—had led Soddy to the conclusion that a large number of bodies, hitherto considered to be simple in character, really consisted of a mixture of one or more constituents, called “ isotopes,” of different atomic masses, but so alike in all their chemical and physical properties that no method of fractionation would provide a means of separating them. Thus while Soddy had established the complex nature of a large number of radioactive bodies previously considered to be simple, Aston’s researches, and, primarily, Thomson’s discovery in the case of neon, extended Soddy’s notion to non-radioactive elements.

Of twenty-nine elements originally studied by Aston, eighteen appeared to be mixtures of isotopes ; the following table shows some of the elements studied :—

Table of some Atomic Weights determined by Aston from the Mass Spectrum

Element.	Classical Atomic Wt.	Least Number of Isotopes.	Actual Weights of the Constituent Atoms (Mass Numbers).		
Boron . . .	10·82	2	11	10	—
Neon . . .	20·20	2	20	22	—
Magnesium . . .	24·32	3	24	25	26
Chlorine . . .	35·46	2	35	37	—
Potassium . . .	39·10	2	39	41	—
Argon . . .	39·88	2	40	36	—
Nickel . . .	58·68	2	58	60	—
Bromine . . .	79·92	2	79	81	—

Different experimenters have sought to separate the various isotopes of an element by means of diffusion through porous diaphragms, or by fractional distillation ; some result has been

obtained in the cases of mercury* and chlorine; chemical methods are, however, quite useless, since the isotopes of the same element have identical chemical properties. The only methods of separation which have any chance of success are those which make use of the difference between the atomic weights.

Thus, although the existence of isotopes has greatly simplified the idea of elementary bodies, practical chemistry is not noticeably affected since the separation of the constituent isotopes of a single element is impossible.

For bodies of which there exists only a single isotope the atomic masses as determined by means of positive rays agree excellently with those obtained by chemical methods; the atomic masses of the various isotopes and those of all the "simple" elements are practically integral numbers when referred to oxygen (taken as 16) as a basis. On this scale, however, hydrogen has an atomic weight equal to 1.008. Except for this reduction of 8 parts in a thousand, *which is fairly constant for all the atoms*, the atomic weights are simple multiples of that of the lightest element. It is natural to imagine that this latter is the elementary constituent of all the others, *i.e.*, that the atom of hydrogen is the fundamental and universal brick in the structure of the universe.

Thus, after the lapse of some years, the old hypothesis proposed by Prout at the beginning of the nineteenth century, *viz.*, that the different elements are composed of a single primordial material, has been restored once more to a place of honour; thus science, through a new discovery, and by a road quite different from that followed for several decades, has found—and not for the first time—the confirmation of an idea which was originally put forward solely as a reasonable hypothesis.

At the same time, this discovery of isotopes caused a considerable upheaval as regards certain fundamental ideas in chemistry; the principle, accepted by Dalton and developed by Meyer and Mendeleieff, of a close relation between the properties of an element and its atomic weight were seen to be defective in two

* J. N. Brønsted and G. Hevesy, *Nature*, 106, p. 144, 1920; 107, p. 619, 1921; *Phil. Mag.*, 43, p. 31, 1922.

respects ; in the first place, in many cases a change of atomic weight was accompanied by no change in the properties of the elementary body ; and then in another field of modern physics—that of radioactivity—there were found to be elements with the same atomic weights (isobares) but with different properties. The properties of an element, then, were not clearly and definitely determined by the atomic weight. Our ideas would have been rather confused had not other wonderful discoveries, viz., those of Moseley, of Soddy, of Fajans and of Rutherford, been made at the same time and thrown light on the matter. We shall return to this subject in Chaps. VIII and IX.

Let us now go back to the consideration of isotopes.

Aston continued his researches in the Cavendish Laboratory, and towards the end of 1927 he published some fresh results on the definite determination of the isotopes of some fifty-seven elements.

Eleven isotopes were found for tin, six for mercury, three for lead, and so on.

Aston also made a very accurate investigation of the loss of mass as indicated by the difference between the atomic weight and the nearest exact multiple of the atomic weight of hydrogen ; it was very important to measure this loss, due to the “packing effect,” as in this way some knowledge could be gained regarding the constitution of the atom, or, rather, the constitution of the nucleus ; this will be understood when we have explained the nature of the nucleus.

The most convenient way of expressing the loss of mass is, clearly, to express the difference between the actual atomic mass and the whole number nearest to it as a fraction of this whole number, and so to obtain the loss or gain as compared with that in the case of oxygen, using the atomic weights referred to oxygen as 16.

This “packing effect,” expressed numerically in this way, gives a clear idea of the strength of the bond which holds together the protons and the electrons in the nucleus ; this is a third fundamental characteristic of the atom, in addition to the atomic weight and the atomic number.

A remarkable fact is noticed when these “contractions” are set

four protons * and two electrons concentrated in a space which is no greater than the volume of a single electron ; and it can be shown by means of the electro-magnetic theory that this close

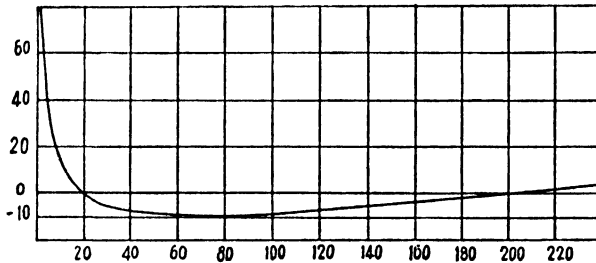

FIG. 49.—Aston's curve. The abscissæ are the atomic weights of the elements and the ordinates are the values of $(m - 1) \times 10^4$, where m is the mass of the hydrogen nucleus in the atom under consideration.

association of the fields in combination is to reduce the electro-magnetic mass.

The following is an example of the isotopes discovered by Aston in 1927 :—

Element.	Atomic Number, or Place in the Classification.	Atomic Weight.	Minimum Number of Isotopes.	Atomic Weights of the Isotopes in Ascending Order of Intensity.			
Sulphur	16	32.06	3	32	33	34	
Tin	50	118.70	11	120	118	116	124
				119	117	122	121
				112	114	115	
Mercury	80	200.60	6	202	200	199	
				198	201	204	

Spectrographs of Aston and of Dempster

The apparatus employed by Aston with such striking success makes use of the rays of different velocities obtained in a discharge tube, just as in the case of the method of parabolas. A bulb

* The proton is the positive nucleus of the hydrogen atom.

contains the anode and the cathode ; these are placed at one end of a long tube along which travel the particles that are to be deflected, first by the electric field and then by the magnetic field. The gas to be examined is fed into the bulb continuously, while a pump keeps the pressure low so that the electric discharge is maintained. The diagram represents the path followed by the rays (see Fig. 50).

The magnetic field is at right angles to the electric field so that both deflections take place in the same plane (that of the figure), but the directions of the fields are such that the two curvatures produced are in opposite directions. S_1S_2 are two parallel narrow

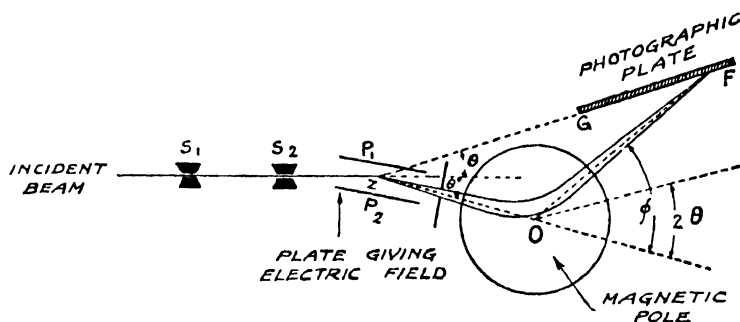

FIG. 50.—Arrangement of Aston's apparatus.

windows which limit the beam ; P_1P_2 are two plates which create the electric field, while the circle with its centre at O represents the poles of the magnet. As we shall explain directly, it is possible to arrange matters so that all particles which have the same value of e/m but different velocities reach the photographic plate at the same point F ; the band traced out on the plate therefore enables the mass to be determined, and it is for this reason that the apparatus is called a *Mass-spectrograph*.

The principle underlying the apparatus is as follows : the rays made up of particles having different velocities are spread out by the electric field, but the magnetic field tends to reunite them so that at a certain distance they converge to a focus ; it can be shown that for this to occur the photographic plate must make an angle θ with the original direction S_1S_2 of the beam, this angle

being the same as the deflection of the beam which is brought about by the electric field.*

Dempster's apparatus is shown diagrammatically in Fig. 52.

The rays which are acted upon by the magnetic field are

* We shall now show how Aston, in his spectrograph, actually succeeds in concentrating at a point the particles which have the same value of e/m , but noticeably different velocities.

Let θ be the angle by which the rays emerging from AB are deflected by the action of the electric field F.

Let ϕ be the angle of deviation produced by the magnetic field H, and consider two rays composed of particles having the same specific charge e/m , but slightly different velocities v and $(v + dv)$. If d and d' are respectively the paths traversed under the influence of the two fields, then

$$\theta = Fed/mv^2 \dots (1) \quad \phi = Hed'/mv \dots (2)$$

These equations at once give

$$d\theta/\theta = -2dv/v \qquad d\phi/\phi = -dv/v$$

and hence

$$d\phi = (\phi/2\theta)d\theta \dots (3)$$

This equation connects the changes of deflection $d\phi$ and $d\theta$ corresponding to rays of velocities v and $(v + dv)$; if these rays strike the photographic

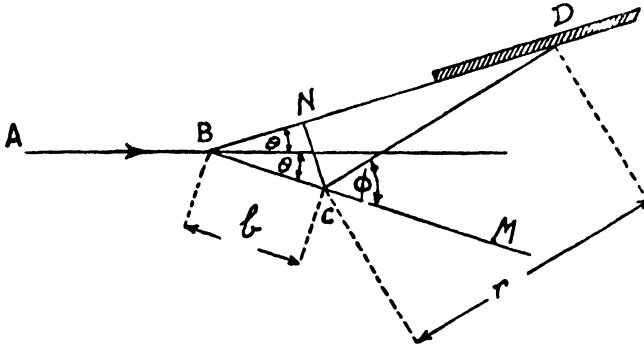

FIG. 51.

plate at a distance r , their separation will be $bd\theta + rd\theta - rd\phi$, and from (3) it follows that this quantity is zero when

$$r = \frac{-b}{1 - \phi/2\theta}$$

Fig. 51 shows graphically the construction which gives a point of convergence D for both these rays. The two lines BC and BD are inclined at an angle θ with the line of the original direction AB, and from C a line is drawn at an angle ϕ with CM.

The point D at which this line meets BD is the point of convergence, for it is easy to show that if θ and ϕ be small, the distance CD is given by

$$CD = -b/(1 - \phi/2\theta).$$

composed of atoms emitted from salts placed on plates of incandescent platinum ; these atoms are emitted at low velocities and are bombarded by the electrons which, after leaving the cathode F, are accelerated by the electric field in the space PS_1 ; the velocity v acquired by these electrons is given by the relation $\frac{1}{2}mv^2 = eP$ where P is the accelerating potential ; finally the rays emerge from the narrow slit S_1 , and, being forced to describe a

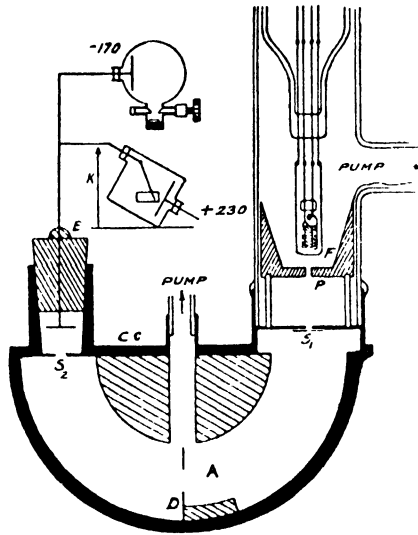

FIG. 52.

circle by the action of the uniform magnetic field, they pass through the diaphragm D. Since the radius r of this circle is defined by the equation $mv = eHr$ the only particles which can pass through the aperture S_2 at the end of the semicircle are those which have the same value of e/m , for from the two relations given above it follows that :

$$e/m = 2P/H^2r^2$$

and, since the radius of the circle is fixed, all the particles that are emitted with velocities other than that given by $v = eHr/m$ cannot pass through the aperture S_2 and are lost. Those particles, however, which pass through S_2 are detected by an electrometer.

From the known values of the field H , and of the accelerating potential, the value of e/m can thus be found.

The diagram of Fig. 53 shows the result obtained by Dempster for the three isotopes of magnesium, and it indicates the relative quantity of each.

In addition, during the last two or three years the study of the

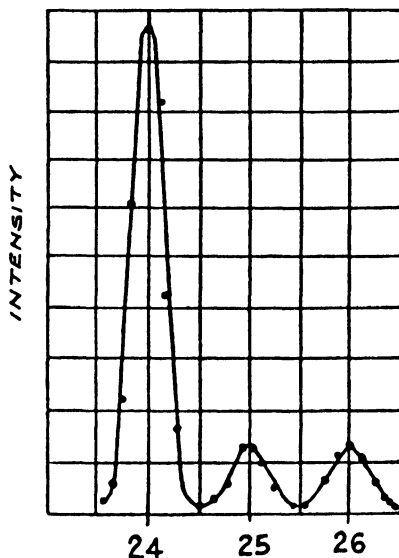

FIG. 53.

spectra emitted by the molecules has enabled the atomic weights of the isotopic elements to be determined with great accuracy by a different method (Mulliken).

BIBLIOGRAPHY

- H. A. WILSON. "Modern Physics" (1928).
 E. N. DA C. ANDRADE. "The Structure of the Atom" (1927).
 "Handbuch der Physik," Vol. XXII., 1926.
 P. BRICOUT. "Ondes et electrons" (1929).
 E. BLOCH. "Les Phénomènes thermioniques" (1923). (English translation by J. R. Clarke.)
 "Conductibilité électrique des métaux," Rapports du IV Conseil Solvay (1927).
 H. KAMERLINGH-ONNES. "Resistances électriques" (1914), Conseil Solvay.
 J. J. THOMSON. "Rays of Positive Electricity" (1923).

- W. WIEN. "Kanalstrahlen" ("Handbuch der Radiologie," Vol. IV.) (1917).
- F. W. ASTON. "Isotopes" (1924).
- A. J. DEMPSTER. "A New Method of Positive Ray Analysis," *Phys. Rev.*, Vol. 11, p. 316, 1918.
- MADAME CURIE. "L'isotopie et les éléments isotopes" (1924).
- J. N. BRØNSTED and G. HEVESY. "On the Separation of the Isotopes of Mercury," *Phil. Mag.*, Vol. 43, p. 31, 1922.
- HAISSINSKY. "L'atomistica moderna e la chimica" (1930).
- B. HOAG. "Electron Physics" (1930).
- W. GERLACH. (English translation "Matter, Electricity, Energy," by F. J. Fuchs, 1930.)

CHAPTER VI

X-RAYS AND THE ATOMIC NUMBER

The Discovery of X-rays and X-ray Tubes

TOWARDS the end of 1895, Röntgen (1845–1923), professor of physics at the University of Würzburg, found that a Crookes tube, if operated inside an opaque pasteboard box, was capable of giving off mysterious rays which produced fluorescence in a screen of barium platinocyanide placed outside the box.

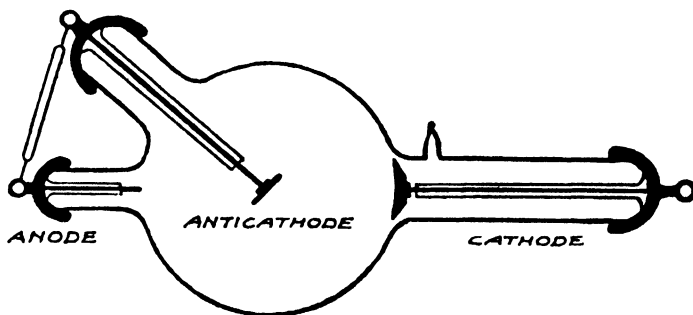

FIG. 54.

He gave to these special invisible rays the name X-rays to indicate their unknown nature.

These rays are produced whenever a cathode stream is abruptly stopped by some material substance ; in Röntgen's experiment they were produced by the action of the cathode rays on the glass of the tube ; now, however, a piece of metal called an anticathode is placed in a Crookes tube and bombarded by the cathode stream so that it emits Röntgen rays in all directions (see Fig. 54).

Gas tubes, in which there is a certain quantity of gas at low pressure, are to be distinguished from *hot cathode* tubes (Coolidge tube class) in which the vacuum is the highest obtainable.

In the former the residual pressure is about 5×10^{-6} atmos. The positive

ions in the gas, formed as a result of the discharge, travel towards the cathode thus producing a large number of electrons by collision, and these electrons make up the cathode stream; they leave the cathode at right angles to its surface, which is a concave segment of a sphere, and from thence they converge to a focal point at which is placed an anticathode of some refractory material, such as platinum, tungsten, molybdenum or rhodium.

These gas tubes have the disadvantage that they require constant attention while they are in use. As time goes on the gas is gradually absorbed and its pressure falls, the voltage which has to be applied across the terminals becomes higher and the current passing through the tube diminishes. It becomes necessary to introduce more gas into the tube, and, in fact, special means are provided to effect this.

The hot cathode tubes, on the other hand, function very steadily. The

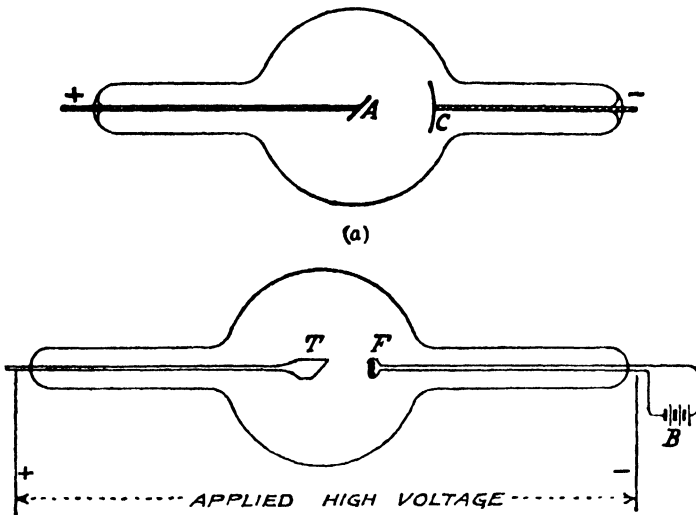

FIG. 55.

typical *Coolidge tube* consists of a glass bulb, 18 cm. in diameter, fitted with two coaxial tubular ends and requires a tension of 220,000 volts. The cathode is a tungsten filament in the form of a flat spiral maintained at incandescence by means of a current of a few ampères under a pressure of some 10 volts, and the emission from this filament is to a large extent focussed on the anti-cathode by the action of a cylindrical or hemispherical cup which surrounds the filament; the equipotential surfaces thus created direct the stream of electrons towards the centre of the anti-cathode.

Until 1914 the applications of X-rays were entirely therapeutic, but after the discoveries of Laue and Bragg, and the arrival of the Coolidge tube in that year, the applications were extended to the industrial field, and they are becoming more important every day.

It will be seen that in the Coolidge tube the electrons are emitted from a metal filament (generally made of tungsten)

heated to redness by means of an auxiliary circuit. This circuit can be regulated by a rheostat and thus the intensity of the electronic current is made independent of the difference of potential applied to the tube ; this potential determines the penetrating power of the radiation produced. With such an arrangement it is possible to control both the *intensity* and the *quality* of the radiation produced, and so, in a series of experiments, to reproduce the same conditions every time. Coolidge tubes are now made in which the operating potential is some 400,000 volts.

Fig. 55 represents a Coolidge tube.

Properties of X-rays

Many substances fluoresce under the action of X-rays : among them are calcium tungstate and barium platinocyanide ; the latter is used for covering the screens employed in radioscopy.

X-rays pass through considerable thicknesses of bodies opaque to ordinary light, and this is their most obvious property. For substances which contain only hydrogen, carbon, oxygen and nitrogen, *i.e.*, elements of small atomic weights, the transparency is high ; substances which contain heavier elements such as sulphur, phosphorus, or calcium, are more opaque, and it is on this fact that the practice of radiography is founded.

Opacity to X-rays increases still more for elements like arsenic, silver or tin, and so on to lead which can stop the rays completely, so that it is used for protective purposes. A few millimetres are sufficient. Now, for a given substance the different kinds of X-rays in a heterogeneous beam are absorbed to different extents (as is the case for a beam of light composed of many different monochromatic components). The transparency of a given substance is used as the basis of a method for distinguishing the various kinds of rays, and these are classified according to their ability to penetrate increasing thicknesses ; the more penetrating rays are called "harder" ; the less penetrating are the "soft" rays.

X-rays are propagated in straight lines with a measurable velocity which is found to be equal to that of light ; in passing through bodies they undergo no appreciable reflection or refraction,

they do not convey any electric charge, and they are not deflected by either an electric or a magnetic field.

The rays ionise any gases through which they pass, and consequently they discharge electrified bodies, since the air surrounding the bodies loses its insulating property. Molecules of gas which lie in the path of a beam of X-rays lose an electron and become positive ions; an electron so emitted has a considerable velocity and in its turn it ionises a large number of molecules, and, after having exhausted its energy, finally attaches itself either to a positive ion or to a neutral molecule, so giving rise to a negative ion; it is these ions that discharge electrified bodies.

The ionisation current which a beam of X-rays produces between two metal plates at different potentials can be used to measure the intensity of the beam. X-rays affect photographic plates. Röntgen's experiments to determine if the rays showed interference effects, using the ordinary optical methods, gave entirely negative results.

The Nature of Röntgen Rays and the Range of their Wave-lengths

In some of their properties the X-rays are similar to light; they travel in straight lines, produce phosphorescence, cause the emission of electrons from metals and affect a photographic plate.

But—and this is the apparently fundamental difference—they do not exhibit the phenomena of reflection, refraction,* or interference when examined by ordinary methods. Shadows cast on photographic plates have perfectly sharp edges, showing that the rays travel strictly in straight lines and cannot bend round obstacles as do rays of light in the diffraction phenomena so extensively studied by Fresnel.

It was suspected that the rays were undulatory in character, like light, and that they were produced as a result of the sudden

* In 1925 Siegbahn showed that refraction did actually occur, and that the refractive index was less than 1, *i.e.*, a beam of Röntgen rays, on entering an aluminium prism, was bent away from instead of towards the base. This deviation is of the order of a minute of arc, *i.e.*, very small indeed.

M. Siegbahn, *Journal de Physique*, 6, p. 228, 1925.

stoppage, by the anticathode, of the electrons forming the cathode stream.

Actually, in 1912, at the time when Laue proved that there was no essential difference between the X-rays and ordinary light, it was thought that the new rays were corpuscular in character; at that time these two conceptions were complete antitheses; it was thought that the one character was quite irreconcilable with the other, and it was never imagined that some fifteen years later a *combination* of both characters could be conceived.*

To prove that the Röntgen rays are undulatory in character, and to measure their wave-length, they must be made to interfere; it is known that the wave-length can be calculated by superposing two rays which, originally derived from the same wave-front, are caused to traverse paths differing slightly in length. Now if the wave-length is very short, much shorter than that of the shortest waves in the ultra-violet spectrum, it will be understood how all the researches carried out on these lines in the case of X-rays were misdirected, and therefore the phenomena of reflection, refraction and diffraction were—apparently—absent.

In fact, from what has been stated as regards the gratings which are used to obtain diffraction phenomena and to measure wave-lengths, it is clear that the spacing of the lines must be of the same order of magnitude as the wave-length of the light to be analysed, and which it is desired to decompose.

For instance, the yellow sodium line for which $\lambda = 0.000589$ cm. is diffracted at an angle of 24° by a grating which has 7,000 lines to the centimetre, *i.e.*, one in which the lines are 0.000143 cm. apart.

Now if the X-rays are similarly undulatory in character, but with a much shorter wave-length than any ordinary light, the gratings available are of no use since they are much too coarse.

* We shall see, in fact, that recent experiments have brought out the dual nature of X-rays. Whilst, on the one hand, it is probable that Röntgen rays will be found to have the properties of electromagnetic waves, such as total reflection, diffraction by gratings and refraction in prisms, on the other hand, there are experiments which have established incontestably that the energy of these rays is granular in character. In contrast with this, experiments of a different kind have shown that a stream of electrons, originally imagined to be corpuscular, behaves like a beam of electromagnetic waves.

$$\alpha_0^2 + \beta_0^2 + \gamma_0^2 = 1 \qquad \alpha^2 + \beta^2 + \gamma^2 = 1.$$

In this way it is found that

$$\lambda = -2a \frac{K_1\alpha_0 + K_2\beta_0 + K_3\gamma_0}{K_1^2 + K_2^2 + K_3^2} \dots \dots \dots (1)$$

The angle 2θ between the incident ray and the emergent ray is given by analytical geometry as follows :— *

$$\sin \theta = (\lambda/2a) \sqrt{K_1^2 + K_2^2 + K_3^2} \dots \dots \dots (2)$$

If, then, a plate of crystalline material be placed in the path

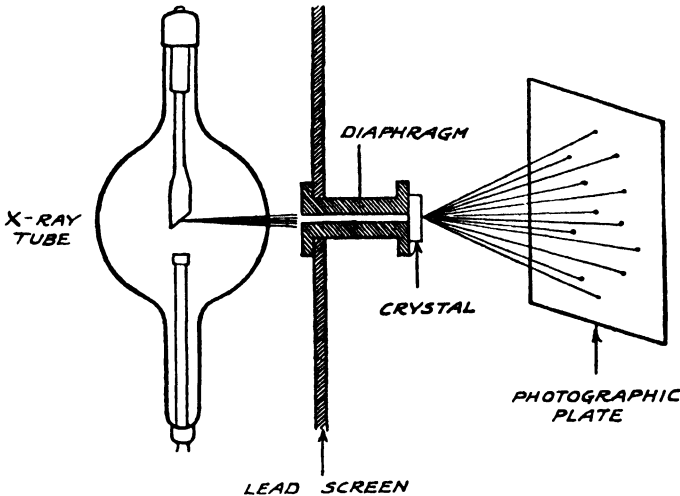

FIG. 56.—The experiment of Friedrich and Knipping on the scattering of X-rays by a crystal.

of a beam of X-rays, diffraction phenomena take place so that the radiation is confined to certain directions, and if the transmitted beam impinges on a sensitive plate, the result is a photograph (or radiograph) consisting not of lines but of spots (Fig. 57).

These are the experiments due to Laue, Friedrich and Knipping ; a narrow pencil of X-rays produced by passing a beam through

* It is sufficient to note that if two lines have respectively the direction cosines $\alpha_0, \beta_0, \gamma_0$ and α, β, γ , the angle 2θ between them is given by $\cos 2\theta = \alpha\alpha_0 + \beta\beta_0 + \gamma\gamma_0$.

a fine tube of lead (1 to 2 mm. in diameter) traverses a crystalline plate, and the resulting diffracted beam is recorded on a photographic plate (see Fig. 56). After an exposure of several hours, according to the power of the tube employed and the transparency of the crystal, a pattern of diffraction spots surrounding a central spot is obtained, this central spot being due to the rays which are not diffracted, and which travel on in a straight line after leaving the lead tube.

If, for example, the crystalline plate (0.5 mm. thick) has—like zinc blende—a tetrad axis of symmetry, the spots are

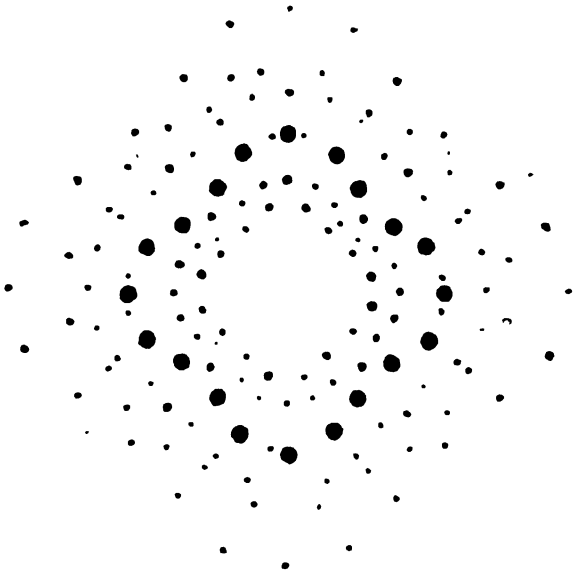

FIG. 57.—A Laue radiograph.

repeated at an angular interval of 90° about the centre of the pattern (see Fig. 57).

This remarkable discovery of Laue opened up a method for examining the internal structure of crystals.

Each spot which recurs at a certain angular interval about the axis of symmetry has the same intensity in each position, and is always produced by rays of the same wave-length. If the record on the photographic plate were coloured according to the wave-length of the Röntgen radiation, the corresponding spots in each

repeat of the pattern would be of the same colour. As an example let us consider a spot for which

$$\alpha_0 = 1 \mid \beta_0 = 0 \mid \gamma_0 = 0 \quad K_1 = 1 \mid K_2 = 1 \mid K_3 = 5.$$

From (1) it is found that $\lambda/a = 2/27$. If, for instance, $\lambda = 4 \times 10^{-9}$ cm., then the constant of the grating $a = 5.4 \times 10^{-8}$ cm. Similarly, if the constant a of the grating is known, λ can be found.

Thus Laue's discovery has opened up two lines of research; one is the study of the spectra of Röntgen rays, the measurement of their wave-length in terms of the constants of a grating, obtained as will be described later; the other is the study of crystal structure by using rays of known wave-length. So far, for the sake of simplicity, we have confined ourselves to the consideration of a cubic system in which the planes of the grating are orthogonal and the diffraction centres equally spaced in all three directions. The complete theory, taking in oblique structures, is somewhat more complicated, but has been completely worked out.

It will be appreciated that it is a very laborious process to interpret a radiograph containing many spots into a description of the particles which have produced these spots.

In order to give a better idea of the way in which these radiographs are produced and how they serve to indicate the internal structure of crystals, we will give an elementary treatment of the subject.

The Internal Structure of Crystals

It is known that crystals are polyhedral in form, with plane faces, and that each chemical substance has a characteristic crystalline form which enables the substance to be identified.

Crystalline forms have been divided into classes and these classes into groups according to the degree of symmetry shown (planes, axes, or centre of symmetry). The external polyhedral shape, *i.e.*, the symmetry of the mass, is the result of the regular arrangement of the constituent particles; these may be imagined to be placed at the corners of a space lattice such, for example, as that shown in Fig. 58.

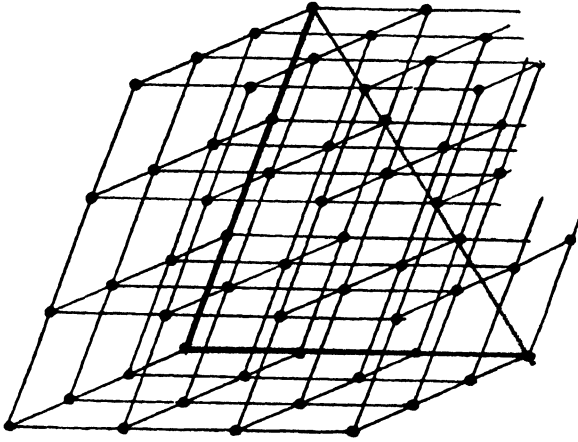

FIG. 58.—The crystal space lattice.

The volume is in this case subdivided into elementary parallelepipeds by means of three sets of parallel planes; the planes in each set are equidistant and parallel. The three sets

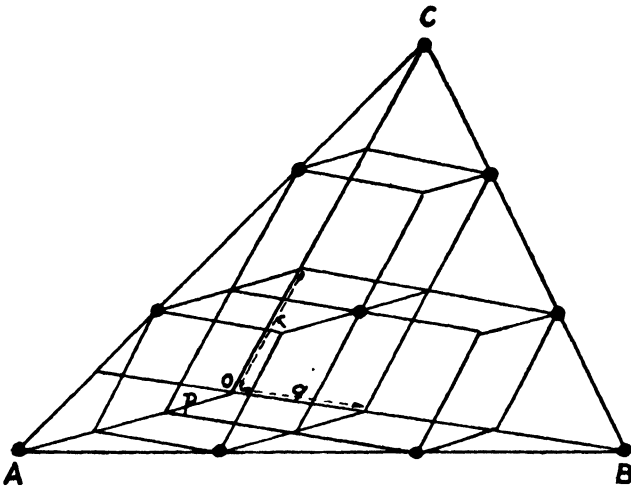

FIG. 59.—A lattice plane in a crystal.

are inclined to each other at different angles, and the distances a , b , c are different. In this way the crystal lattice is produced.

It is thought that the faces of the crystal correspond to the different ways in which a geometrical plane can be placed so as

to pass through an indefinite number of these corners, termed the *nodes* of the crystal space lattice.

For instance, the three nodes A, B, C determine a crystal face or, more generally, a *plane of the lattice* (see Fig. 59).

When mention is made of the axes of reference of a crystal, three directions oA , oB , oC are taken at will to describe the position of any face; it is clear that the intercepts of any face

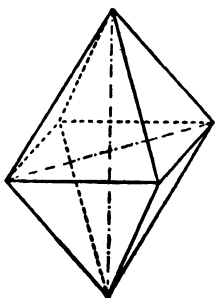

FIG. 60.

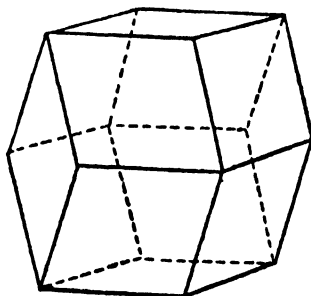

FIG. 61.

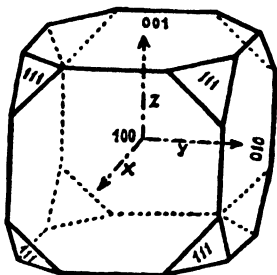

FIG. 62.—The cube and the octahedron.

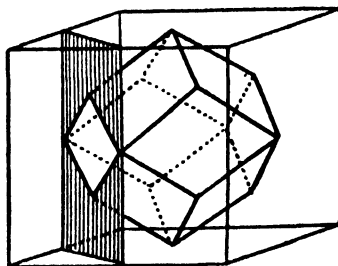

FIG. 63.—The rhombic dodecahedron.

on the three axes will be lengths oA , oB , oC , so that the ratios oA/p , oB/q , oC/r have the same relative values as three integral numbers, p , q , r being the three intercepts on the axes and therefore multiples of the three fundamental distances.

In this way a face is defined by three whole-number “indices” —for instance, 2, 1, 3 or 0, 1, 2—and this combination can always be arranged so that one of the indices is equal to unity, for what matters is the position of a face in relation to the others, and not its absolute position; in crystals, in fact, the faces occur parallel

to each other, and two crystals are the same when all the faces of one are parallel to those of the other.

Thus we speak of the face 111; this face cuts all three axes of reference at equal distances from their origin; if these axes are orthogonal, the symbol 111 stands for one of the faces of a regular octahedron; the symbol $\bar{1}\bar{1}\bar{1}$ stands for another face, and the whole system, *i.e.*, the octahedron, is expressed by means of the symbol (111). A very special case is that in which the crystal lattice consists of planes which are mutually perpendicular and which are equidistant; this gives rise to the cube.

In crystals of the cubical system, three kinds of faces are most frequently found, *viz.*, those corresponding to the indices 100, 110, 111. The first symbol refers to the faces of the cube which are each parallel to two axes of references, as indicated by the two zeros of the symbols $\bar{1}00$, 010 , 001 , $00\bar{1}$, etc., all of which are summarised in the symbol (100).

The symbol (110) refers to the rhombic dodecahedron, while (111) stands for the octahedron as stated already. The rhombic dodecahedron is, of course, a regular polyhedron with twelve equal sides, each side being a rhombus.

Radiographs

Let us follow Bragg and consider an example of a *two-dimensional structure*, made up of diffraction centres which are all alike, as in the case of a nickel crystal, or of centres of two different kinds (sodium chloride).

An idea of the first case may be gained from Fig. 64, while Fig. 65 gives an idea of the second case.

The symbols (11), (21), (31), (41) in Fig. 64 indicate the indices of the different faces which, in the case of an actual three-dimensional crystal, are triple instead of double. In Fig. 66, which represents the corresponding radiograph, AO is the beam of heterogeneous incident radiation; OP_1 , OP_2 , OP_3 are the reflected rays, P_1 , P_2 , P_3 the spots obtained on the radiograph. It is known that when a beam of monochromatic light falls on a plane reflecting surface, every point which receives light becomes a centre of vibration, and there is a single and well-defined

direction along which the reflected rays are in the same phase ; this special direction is the direction of the reflected beam, and is symmetrical with the incident beam about the normal to the plane (see Fig. 67).

Only one path is open to the reflected beam, and to every angle of incidence there corresponds a single angle of reflexion. When, however, as in the case of crystals, the regularly spaced

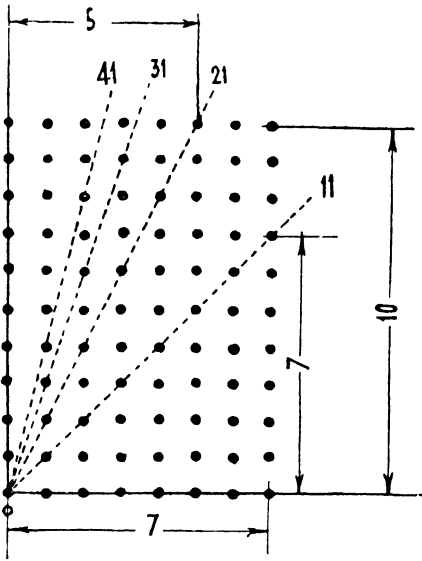

FIG. 64.—Plane lattice of particles of one kind.

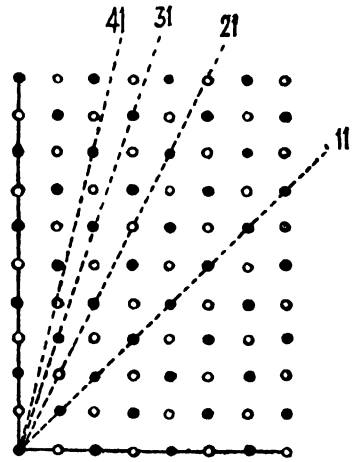

FIG. 65.—Plane lattice of particles of two kinds.

planes lying below the surface plane take part in the diffraction, it follows that for any arbitrarily chosen angle of incidence there will no longer be any reflected beam, because—save in exceptional circumstances—the reflected rays will be unlike in phase on account of the distances they have travelled within the crystal ; thus a monochromatic beam is not usually reflected unless there is a special relationship between the separation distance δ of the planes (see Fig. 68), the wave-length of the radiation and the angle θ at which the light enters the crystal. On the other hand, when a heterogeneous, and not a monochromatic, beam enters the crystal there must be, among the infinite range of

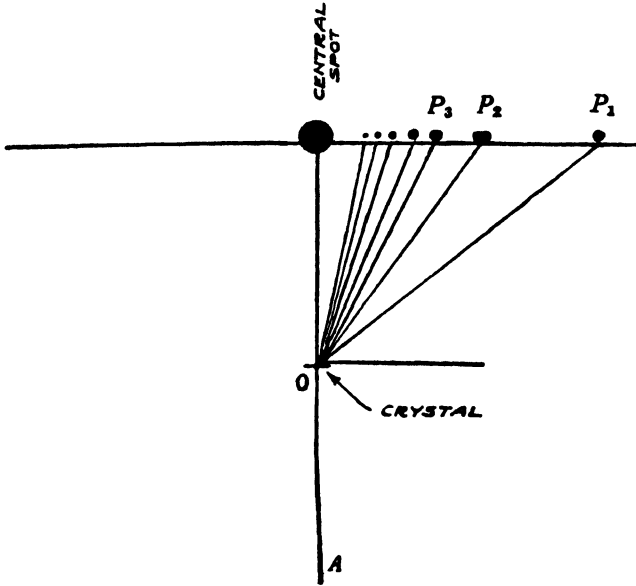

FIG. 66.

radiations of which it is composed, one which will have a wavelength such that it fulfils the condition referred to above, and this component will therefore be reflected. The condition to be satisfied is, as we shall show, $\lambda = 2 \delta \sin \theta$ (see p. 256).

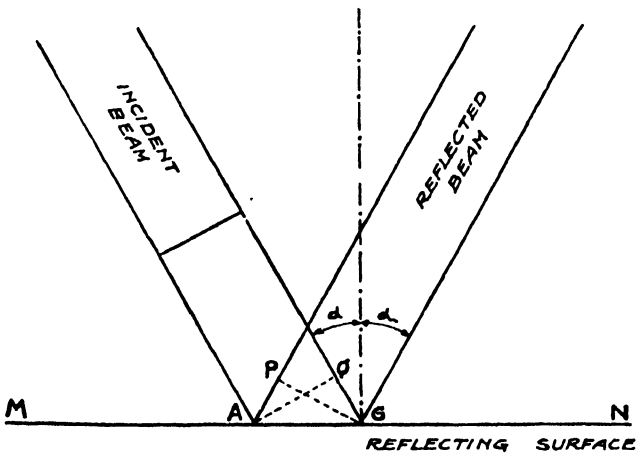

FIG. 67.—The phenomenon of reflection.

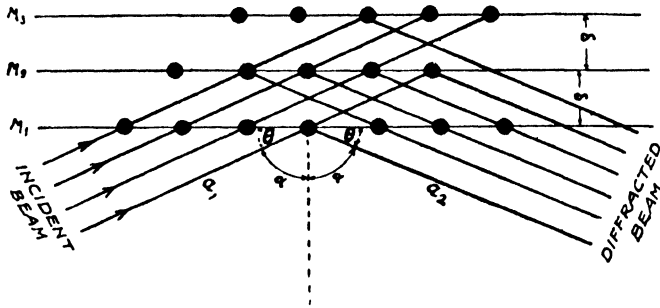

FIG. 68.—Reflection at successive lattice planes.

It will be seen that from the distribution and the intensity of the spots it is possible to build up a picture of the crystal structure, since the order of succession of the wave-lengths forming these spots is known.

We shall take as examples the radiograph of sylvine (potassium

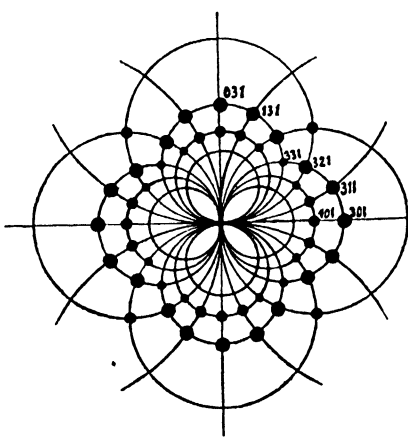

FIG. 69.—Radiograph of sylvine.

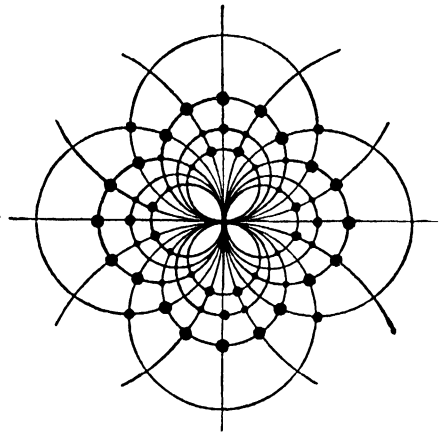

FIG. 70.—Radiograph of rocksalt.

chloride) and that of sodium chloride, shown in Figs. 69 and 70.* We shall now show how it is that these spots are arranged in circles.

Laue's diagram is obtained with Röntgen rays having a continuous spectrum, *i.e.*, with the radiation given by an X-ray tube. Each group of

* These figures show the so-called *stereographic* projection, in which the ellipses on which the spots lie are projected into circles.

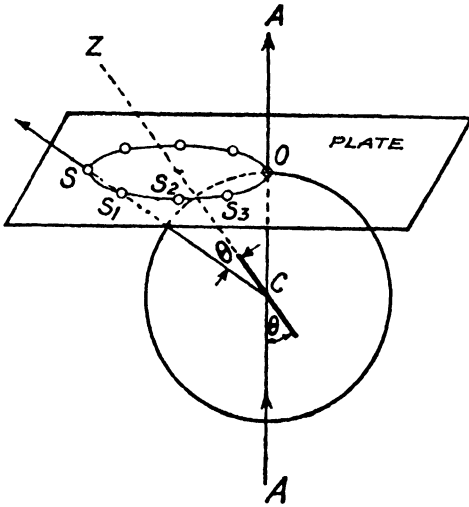

FIG. 71.

regularly spaced planes is thus enabled to select from the incident radiation the wavelength which suits its position and its spacing, so that this radiation will be selectively reflected in a direction which is fixed in relation to that of the incident beam. This method of Laue's gives, therefore, the orientation of the planes and the type of symmetry of the crystal under examination, but it does not give the dimensions of the elementary cell in the lattice.

The typical Laue diagram shows a circular central spot, which is the record of the undeviated beam, and this is surrounded with spots arranged so as to lie on a series of ellipses; these ellipses are arranged symmetrically if the

incident beam is sensibly coincident with the axis of symmetry of the crystals. The problem now remaining is to connect the position of a spot with the index of the reflecting plane which produces it.

In this connection let us consider Fig. 71. The spots are arranged on ellipses which pass through the central point O, where the incident beam of Rontgen radiation meets the plate. The crystal is placed at C and the angle between the incident beam and the reflecting face of the crystal (perpendicular to the plane of the paper) is θ . The ray CS makes an angle 2θ with the line CO; the other rays $CS_1, CS_2, CS_3 \dots$ correspond to reflections at the same angle θ .

The rays CS_1, CS_2, CS_3 are the generators of a circular cone having CZ as its axis and 2θ as its vertical angle. Hence, they intersect the plate L in points lying on an ellipse.

If a stereographic projection of this ellipse be formed, as in Fig. 72, the ellipse becomes a circle, and circles such as these make up the diagrams shown in Figs. 69 and 70. This projection is carried out as follows (see Fig. 72): the point S is joined to the centre C of the sphere whose radius is CO and the point M in which

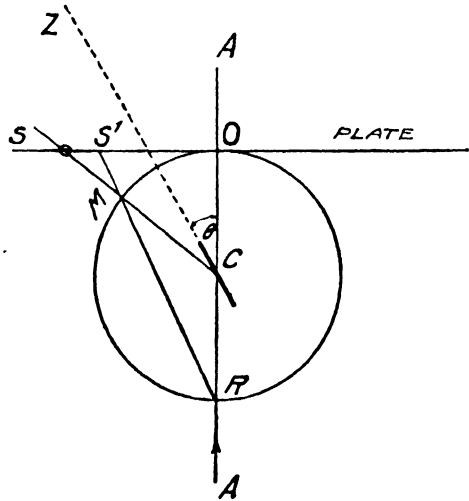

FIG. 72.

CS intersects the surface is projected on to the plate. The ellipse is thus contracted along its major axis and becomes a circle.

A careful study of these figures and of many others has led to the conclusion that the particles which are situated at the nodes of the crystal lattice and which determine the reflection pattern by the positions of the planes passing through them are not the molecules, but the ions. Thus in a crystal of potassium chloride, which, like sodium chloride, belongs to the cubic system, the atoms of chlorine are separated from the atoms of the metal.

It will be readily understood how the radiograph given by such a system may have well-defined connections with that given by a system consisting entirely of particles of one kind.

This division of the reflecting planes into two categories is responsible for the special appearance of the spots, which are found to fall into two regular groups.

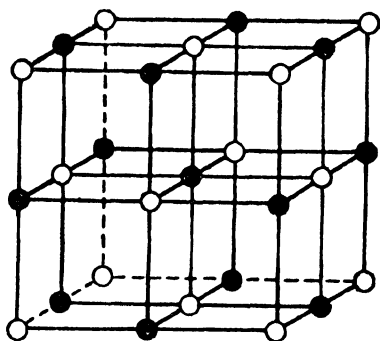

FIG. 73. Lattice of rock-salt: The halides of the alkali metals (KCl, KBr, KI, NaBr, etc.) have the same lattice form.

Thus from Fig. 70 we can form a picture of the three-dimensional structure of the crystal lattice of rock-salt, called a *cubic face-centred lattice* (Fig. 73).

Moseley's Discovery *

Moseley, the young English physicist who was already famous at the age of twenty-five and who was killed in the Dardanelles campaign in the World War, made a systematic study of the emission of Röntgen rays as related to the periodic arrangement of the elements.

The anti-cathode of an X-ray tube emits radiation of all frequencies as a result of the sudden stoppage of the electrons which make up the cathode stream; and in this way the so-called *continuous spectrum* is produced; at present we shall neglect this

* H. G. J. Moseley, *Phil. Mag.*, 26, p. 1024, 1913; and 27, p. 703, 1914.

spectrum. Superposed on it, however, the photographs show some very fine lines, and these are the lines which Moseley studied systematically.

The spectrum, which consists of a few lines, is atomic, *i.e.*, it is almost entirely independent of the nature of the chemical combination in which the element forms a part; in other words, an atom is always characterised by its own invariable X-ray spectrum, no matter what may be the compound or the alloy in which it is present. Brass, which is an alloy of copper and zinc, gives rise simultaneously to two spectra which are respectively characteristic of the two components when these are used separately.

In the case of cobalt, which it is difficult to separate from nickel and from iron, the lines of the latter are in no way interfered with by those of the former element. This is the chief characteristic which is responsible for the simplicity of X-ray spectra.

Bromine, which cannot be used as an element to form an anti-cathode, may be studied in its compounds with other elements as a result of the property which has just been described.

The high frequency part of the spectrum, then, enables the elements to be detected in any of their combinations, and this provides direct proof of their unalterability throughout all kinds of chemical transformations.

Thus X-ray spectra are much simpler than light spectra; while the latter may consist of hundreds or sometimes even thousands of lines, the former consists of a small number of lines grouped in a few series which are referred to by the letters K, L, M in order of increasing wave-length.

The X-ray spectra of the various elements show, in fact, a striking similarity, for there are groups of lines which maintain the same relative positions and the same relative intensities as we pass from one element of the periodic classification to another, and each line of every group is similarly repeated in going from one element to the next (see Fig. 74).

In any given spectrum the K series is that containing the highest frequencies, and in this series four lines are to be seen,

called respectively α , α' , β_1 , β_2 . The first two are the closest together.

If, then, various elements are taken in the order of increasing atomic weight, it will be seen that there is a gradual and uniform displacement of the systems of lines; Moseley examined more than forty elements, from aluminium to gold, using the element under observation as the anti-cathode in a tube producing X-rays and so obtaining the characteristic lines; he measured the wave-lengths by means of an analysing crystal of potassium ferrocyanide, for which the constant d was known to be equal to 8.454×10^{-8} cm.

The exploring chamber* used for examining the reflected radiation contained the photographic plate which recorded the impression of the beam of X-rays coming from the crystal; every characteristic line was measured by making a very accurate determination of the angles corresponding to the first two orders in the diffraction pattern so that the wave-length was calculated from the

relations $\lambda = 2d \sin \theta_1$ (first order) and $\lambda = d \sin \theta_2$ (second order).

To Moseley belongs the credit of having found the law governing the change of frequency of a given line with change of the element giving rise to it.

For every line in the X-ray spectrum the square root of the frequency ν is a linear function of the atomic number.† This means that if a graph be plotted with abscissæ showing the atomic weights or,

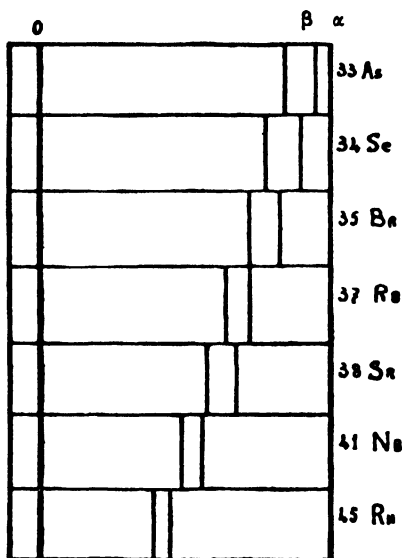

FIG. 74.

* The spectrometers used for finding the wave-lengths of X-rays are described on p. 260, Figs. 84 and 85.

† As we shall see, the relation is *almost* linear.

better, the atomic numbers, *i.e.*, the numbers indicating the position of the atom in the periodic table, while the ordinates represent the values of $\sqrt{\nu}$ for any given line in the spectra due to various elements, then the resulting points lie on a straight line.

The same is true of the L series and of the M series.

Moseley's law may thus be expressed mathematically by means of the equation

$$\sqrt{\nu} = a(N - b),$$

where a and b are two characteristic constants of the line under consideration, *e.g.*, the K line. For this line the above formula becomes

$$\nu_{K\alpha} = 82303(N - 1)^2,$$

where N is the atomic number, *i.e.*, the rank of the element in the periodic classification.

In order to give a numerical illustration of what has just been described we shall now give the wave-lengths of the K series in X units. This unit of length was introduced by Siegbahn, the well-known physicist who continued Moseley's work; in 1919, Siegbahn, having perfected the methods of measurement, so increased the precision of the wave-length data that it was necessary to introduce a much smaller unit than the Ångström in which to express them. The new unit, called the X, is the thousandth part of the Ångström unit, so that one X = 10^{-11} cm.

Wave-lengths of the K Series in X units

Atomic Number N and Name of Element.	α' or α_2 .	α or α_1 .	β_1 .	β_2 or γ .
Sodium 11. .	11,883	11,883	11,591	—
Silicon 14 .	7,109	7,109	6,739	—
Calcium 20 .	3,355	3,352	3,083	3,067
Manganese 25 .	2,101	2,097	1,905	1,893
Zinc 30 .	1,435	1,432	1,292	1,281
Molybdenum 42 .	712	708	631	619
Antimony 51 .	474	469	416	407
Tungsten 74 .	213	209	184	179

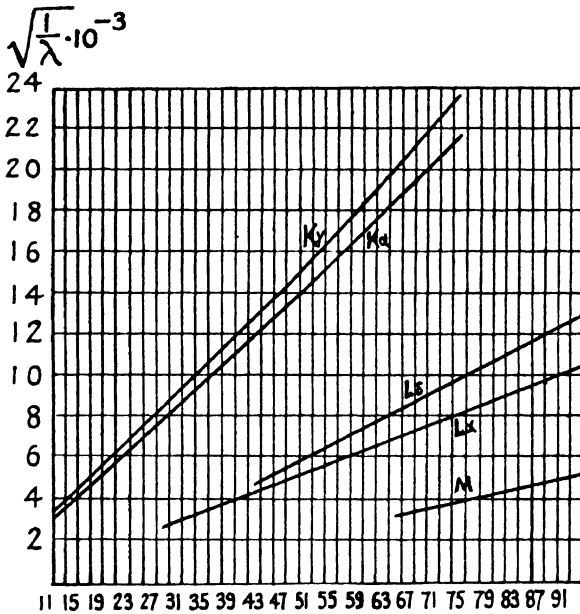

FIG. 75.—The relation between the wave-lengths of the K, L, M series and the atomic numbers of the elements.

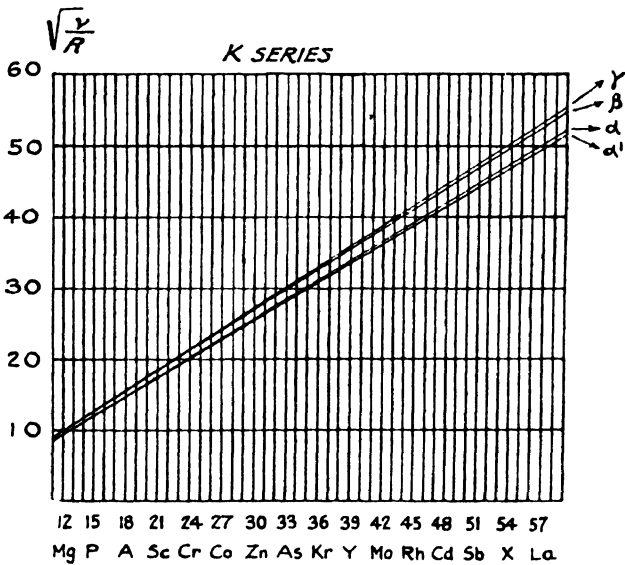

FIG. 76.

From the figures given in the table on p. 232 it is possible to verify Moseley's law.

The K series is only well established for the elements lying between oxygen and uranium, and this for the following reason : the hardness of the X-rays increases in each series as the atomic weight increases ; sodium and the elements immediately below it give rays which have so little penetrating power that it is difficult to study them.

The approximate proportionality between the square root of the frequency and the position number of the element holds for all homologous lines, *i.e.*, for $K_{\beta 1}$, $K_{\beta 2}$, L_{α} , $L_{\beta 1}$, $L_{\beta 2}$, M_{α} , M_{β} , etc. (see Fig. 75).*

We give below a few values for the L_{α} radiation. The wave-lengths are expressed in X units.

Atomic Number.	Atomic Weight.	Element.	Wave-length.	Square Root of Frequency.
30	65.38	Zinc . .	12,222	4.95×10^8
45	102.9	Rhodium . .	4,588	8.06×10^8
55	132.81	Cæsium . .	2,886	10.2×10^8
82	207.2	Lead . .	1172	15.98×10^8
92	238.2	Uranium . .	908	18.1×10^8

Moseley's law placed beyond all question the relationship existing between the different elements, a relationship which was first established, though on a very much less secure basis, by Mendeleieff ; the high frequency spectrum is determined by the atomic number and, conversely, from a knowledge of the spectrum it is possible to deduce the atomic number with absolute certainty ; the high frequency spectrum alone serves to define precisely the nature of an element and its position in the periodic classification ; this position is identical with that determined by the chemical properties, and, apart from a few inconsiderable exceptions, with the order based on the atomic weights.

* In Fig. 76 R is the Rydberg constant (expressed as a frequency) to which we shall refer in Vol. II, Chap. II. For the present it is sufficient to state that it is a constant ; its value is 3.2775×10^{16} sec.⁻¹.

Now, *these exceptions are just the cases in which similarity of chemical properties indicates that there should be a departure from the strict order of the atomic weights.* Tellurium (at. wt. 127·5), which shows a striking similarity with selenium, must now be placed before iodine, which has an atomic weight of 126·92, in spite of the greater atomic weight of the former element ; if this is done, tellurium falls into the same column as the element it resembles. Cobalt and nickel, too, cause another inversion, the former (Co = 58·97) being now placed before nickel (Ni = 58·68). In order to bring argon into the column of the rare gases, so that it may be amongst its analogues, it has to be placed before potassium, and in this way the latter element occurs in the same column as sodium and lithium where it naturally belongs. In spite of these anomalies, which caused Mendeleieff's classification to appear somewhat arbitrary, it emerged triumphant from all criticism ; it was hoped, and indeed believed, that this classification was based on a real periodicity in properties as the atomic weight increased, and that it would therefore provide a basis for a philosophical explanation of nature ; Moseley then showed that the order of succession of the spectral lines in the high frequency spectrum corresponded exactly with the order of succession of the elements ; tellurium occurred before iodine as it naturally should, cobalt before nickel and potassium before calcium. Moreover, the known elements left gaps in the series of lines, and these gaps belonged to the elements which were still unknown. It was thus proved that there could never be discovered, either on the earth or elsewhere in the universe, any new elements with atomic weights lying between 11 and 92, *i.e.*, between sodium and uranium, other than those which had already been indicated as unknown ; at the time of Moseley's work (1913) the vacant spaces were six in number and the confirmation was a matter of great interest.*

The essential significance of Moseley's law is not that the square root of the frequency is a simple function of the position of the element in the periodic arrangement, but that there exists a

* At the present time there are only two vacant places.

property, the X-ray spectrum, which is a continuous function of this position ; this fact establishes the existence of a common basis for the structure of all the various atoms, a basis which can control this property of the atom, and this structural basis must be such as to change gradually and uniformly on passing from one position in the periodic table to another. Since this simple linear relationship between the atomic number and the frequency no longer holds if the atomic weight be substituted for the atomic number, it seems clear that the latter and not the former is the independent variable which must be considered when studying the successive variations in the properties of bodies.

The Continuous Background Spectrum and its Limit

As has been said already, an X-ray tube emits a spectrum composed of a continuous background on which are superimposed the bright lines characteristic of the element forming the anti-cathode ; the former part is also referred to as the "general," or "independent," radiation, since it does not depend on the anti-cathode which is used, but is made up of an infinite number of homogeneous radiations as in the case of the white light spectrum. Let us consider a hot cathode tube, the Coolidge tube.

The Coolidge tube allows the intensity and the penetrating power of the X-rays to be controlled very easily ; the intensity may be increased by raising the current through the filament and so increasing the number of electrons emitted ; the hardness is increased by raising the voltage applied across the electrodes ; it is thus possible to obtain a strong or a weak dosage of rays of any desired degree of hardness.

Let one of the hot cathode tubes be operated at constant potential V ; the electrons arrive at the anti-cathode with an amount of energy which can be varied at will by adjusting V . By means of a spectrometer with an ionisation chamber it is possible to measure the intensity of the ionisation produced by the rays reflected from the crystal at various angles. In this way the spectral distribution of the radiation can be determined at any given potential and the curve showing the intensity of the radiation at each wave-length can be drawn.

By varying the potential across the tube, a similar curve may be obtained for each selected value of V , and so the complete diagram shown in Fig. 77 may be constructed.

In a similar manner it is possible to use a constant angle (*i.e.*, a single wave-length) and to trace the curve connecting the intensity of this homogeneous radiation with the potential applied across the tube; these latter curves are called *isochromatic*, for an obvious reason, and have the form shown in Fig. 78.

The two methods of working are equivalent, and, clearly, lead to the same results.

Now from Fig. 77—or equally from Fig. 78—it will be seen that the intensity of the spectrum becomes zero for a *maximum* frequency ν_0 at each potential V_0 , and it is found that between these two quantities there exists the simple relation $\nu_0 = V_0(e/h)$, where h is constant throughout.

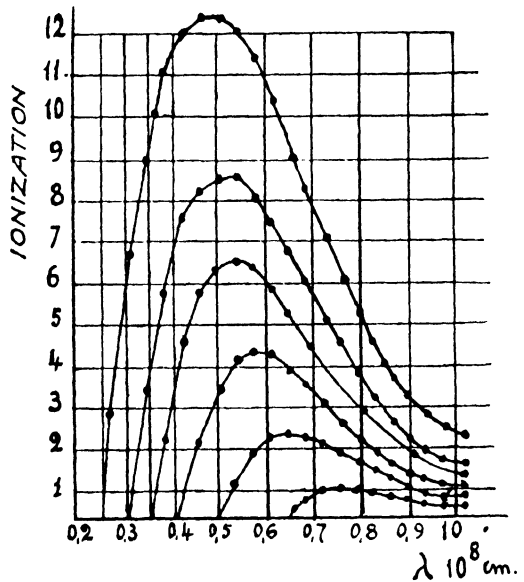

FIG. 77.

For instance, at 38,000 volts the radiation $\lambda = 0.318$ Ångström has zero intensity; at a lower voltage, *e.g.*, 25,000 volts, the ionisation due to the radiation is reduced to zero at a lower frequency, and, in fact, ν_0 and the voltage V_0 vary in the same ratio as above stated.

Thus the starting points of the various curves obtained at voltages of 20, 30, 40 and 50 kilovolts represent frequencies which lie on a straight line if they are plotted on a diagram showing corresponding values of ν_0 and V_0 .

This law is of very great importance; the constant h appears in the formulæ expressing many of the most diverse physical

phenomena and is called *Planck's constant*,* or the radiation constant for reasons which we shall see later.

A number of physicists have verified this law by means of experiments carried out on various metals, especially during the years 1915–1919.†

The value of h is 6.55×10^{-27} erg sec. It is expressed in erg seconds because the product eV_0 is work and frequency is the reciprocal of time, so that the ratio $h = eV_0/\nu_0$ really has the dimensions of *energy* \times *time*. A given radiation ν_0 , then, does not

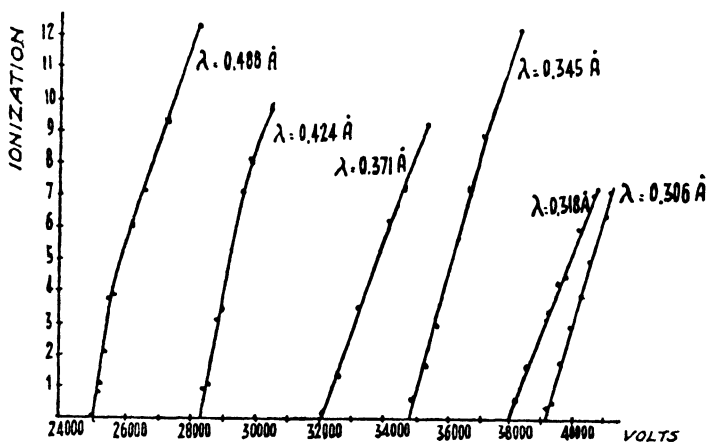

FIG. 78.—Isochromatic curves.

appear unless eV_0/h exceeds ν_0 , *i.e.*, unless the voltage attains the corresponding critical value.

This is the significance of the results obtained experimentally. The highest voltages practically attainable are now about 200,000 volts; the electrons then acquire a velocity of 260,000 km./sec., close to the velocity of light, as can be easily calculated from the relation $\frac{1}{2}mv^2 = Ve$.

If, instead of considering the continuous spectrum, as we have done so far, we turn our attention to the rays which are characteristic of the metal used for the anti-cathode (tungsten,

* From the name of the celebrated physicist, Max Planck, professor at Berlin, and founder of the quantum theory.

† W. Duane and F. L. Hunt, *Phys. Rev.*, 6, p. 166, 1915. D. L. Webster, *Phys. Rev.*, 7, p. 599, 1916. F. C. Blake and W. Duane, *Phys. Rev.*, 10, pp. 93 and 624, 1917. E. Wagner, *Phys. Zeits.*, 21, p. 621, 1920.

molybdenum, platinum, etc.), it is found experimentally that in order to excite the rays of any group, the energy of the electrons coming from the cathode must be *at least equal* to that which corresponds with the line of the highest frequency in the group as calculated from the relation $h\nu = Ve$; no line in a group appears, in fact, until the energy of the electrons travelling towards the anti-cathode attains the value $h\nu$, *i.e.*, 6.55×10^{-27} multiplied by ν .

When this value has been reached, then *all* the lines appear at once.

The existence of these lines of maximum frequency ν_0 , all produced at once when the energy of an electron $Ve = \frac{1}{2}mv^2$ is sufficiently high, suggests that there exist within the atom certain *levels of energy*. To form a clearer idea of the matter let us imagine the following mechanical system:—

A number of equal masses P are placed at different levels K, L, M, N (see Fig. 79) in a

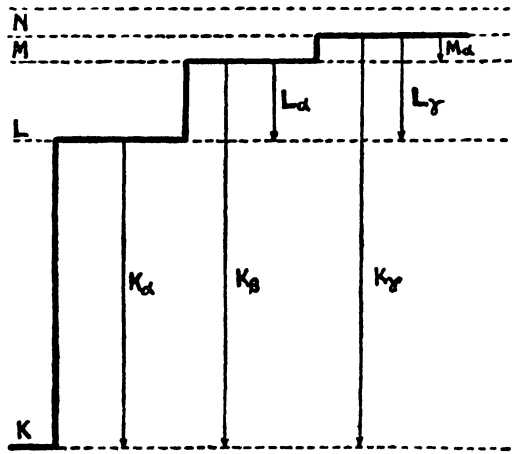

FIG. 79.

field of force which decreases rapidly upwards. The first of these masses, if it be given sufficient energy, may be thrown upwards and move off to infinity, leaving its place vacant; this may happen provided the kinetic energy ($\frac{1}{2}mv^2$) imparted to the mass is equal to the work required to remove it to infinity. For a mass P situated at the level L, the energy required will be less since the level is higher. With a system such as this the removal *to infinity* of a mass from the level K, or its removal from the level L to infinity, will be followed by the fall of a mass which descends to fill up the vacant space and the phenomenon will be accompanied by the emission of monochromatic radiation. We have the emission of the line K_α if the mass comes from the nearest level,

of the line K_β if it comes from the next but one, of the line K_γ if it comes from the next but two, and so on ; equally the emission of the lines L_α , L_β , L_γ , etc., is the result of a vacant space at the level L.

With this system it will be understood that the work which has to be done in order to create a vacant place is greater the lower the level under consideration, and it is immediately apparent why—given sufficient energy for the creation of a vacancy—all or none of the lines in a K series appear according as the energy available is or is not sufficient to remove to infinity a mass situated at the K level. The lines, therefore, all appear simultaneously if these necessary amounts of energy are supplied continuously, for the vacancies created will be filled by masses falling from all the different levels. In conclusion, the fact that, for any one body acting as an anticathode, all the spectral lines of a K series appear simultaneously, and that in order to make them appear the energy needed is $h\nu$, proportional to the frequency of the “highest” radiation, suggest that the atom does actually possess a similar structure with energy levels. It is the constituent electrons which convert the potential energy of the atomic system and are responsible for the emission of the spectral lines.

We shall see later, in Vol. II, Chap. II, that these energy levels do actually exist within the atom, and that they can be measured. This explains quite satisfactorily the experimental fact—which is here only referred to in passing—that, until the energy $Ve = \frac{1}{2}mv^2$ of the cathode particles reaches a value sufficient to enable it to plunge—as it were—into the internal structure of the atom, none of the characteristic rays is emitted, but on the other hand, when one is emitted, the whole series is emitted. At this stage it is not possible to explain why the energy Ve and the *maximum* frequency excited should be connected by means of the simple relation $\nu = Ve/h$, where h is a constant for all frequencies, for every metal and without any exception whatever.

The use of Gratings in X-ray Spectroscopy

Jean Thibaud, in 1925,* succeeded in obtaining X-ray spectra

* J. Thibaud, *Comptes Rendus*, 182, p. 55, 1926.

by means of a grating on glass having 200 lines to the millimetre and in measuring the wave-length by this method ; the result is remarkable and seems at first sight to contradict what has been said as to the extreme smallness of the wave-lengths of these radiations and the consequent impossibility of applying spectrographic methods to them. After the work of Laue and Bragg in studying X-rays, crystals were used exclusively, as these naturally occurring gratings were on an atomic scale ; Thibaud, however, conceived the idea of going back to an ordinary type of line grating, and of obtaining the diffraction effect by causing the beam of rays to strike the grating at *grazing incidence* (see Fig. 80)

We have seen already (p. 28) how the elementary theory of

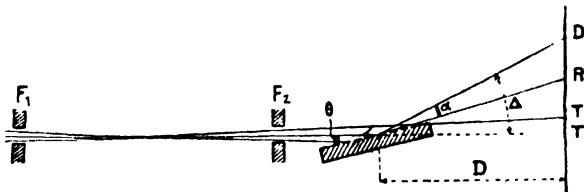

FIG. 80.—Thibaud's grating spectrograph for X-rays.

the plane grating shows that if a beam of rays strikes a reflection grating at any angle, the monochromatic diffracted rays lie symmetrically on either side of the regularly reflected beam ; if the grating has $1/m$ lines per unit length, the diffracted ray of the n th order for radiation of wave-length λ is reflected at an angle i' where

$$n\lambda = m (\sin i - \sin i')$$

or, measuring angles from the plane of the grating,

$$n\lambda = m (\cos \theta - \cos \alpha + \theta).$$

If a narrow pencil strikes the face of the grating very obliquely (see Fig. 80), making with it a very small angle θ , we may substitute for $\cos \theta$ and $\cos (\alpha + \theta)$ the first two terms of the series representing them, so that

$$n\lambda = \frac{1}{2} m (\alpha^2 + 2\alpha\theta) = \frac{1}{2} m\alpha (\alpha + 2\theta) \dots (1)$$

(rock salt, or calcite) for which the spacing in the lattice is known ; actually, on the assumption that for rock salt *

$$d = \sqrt[3]{M/2N\rho} = 2.814 \text{ \AA.}$$

where N = Avogadro's number

ρ = density of rock salt

M = molecular weight of rock salt,

the value found for λ is 1.538 \AA .

In addition to total reflection, *diffraction at a slit* has been detected in the case of X-rays ; Holweck and Bäcklin, for instance, have conducted experiments with the K_α radiation of aluminium and have found as many as forty clearly defined fringes.

Finally, some physicists have succeeded in demonstrating and measuring the polarisation of X-rays, *i.e.*, the existence, in certain circumstances, of a plane of preference for the transverse vibrations.

The Absorption of X-rays

This is a very complicated subject, and in order to avoid overloading the discussion we shall endeavour to bring out the fundamental points in a few words.

It is found experimentally that when X-rays pass through a material they are partially absorbed ; a monochromatic or homogeneous radiation loses equal fractions of its energy as it passes in succession through a series of identical screens. If I_0 represents the initial intensity of such a radiation and I the intensity observed after passing through any thickness x , then $I = I_0 e^{-\mu x}$, the usual exponential relation appropriate to phenomena of this kind ; μ is a numerical coefficient called the *linear absorption coefficient* ; anyone who has made a slight study of physics knows that this equation is obtained by integrating the differential equation $dI = -\mu I dx$, which signifies that the quantity of energy absorbed in a layer of thickness dx is proportional to the amount of energy reaching that layer.

The linear absorption coefficients of the different substances are measured by means of the ionisation spectrometer, placing different thicknesses of the substance under examination in the

* See p 258.

path of the beam. The crystal, as we know, isolates a wavelength λ , and the ionisation chamber gives the intensities with and without a layer of material interposed. These figures show that the initial intensity I_0 and the final intensity I are connected by the equation

$$I = I_0 e^{-\mu x},$$

and from this equation the value of μ , the linear absorption coefficient, can be calculated for different values of λ and different materials.

The linear absorption coefficient, then, is a measure of the absorption per unit volume, taken across unit cross-section. On taking logarithms we have $(1/x)\log(I_0/I) = \mu$, and it will be seen that $(\log I_0 - \log I)/x$ should be constant; this provides an experimental test for the homogeneity of a beam of rays, since in the case of a heterogeneous beam the relation between $\log I$ and the thickness ceases to be linear.

The effect of the physical conditions of the material on the value of μ is negligible to a first approximation; *i.e.*, the temperature and the pressure do not bring about any variation in μ provided there is no variation in the density; thus the ratio μ/ρ between the linear absorption coefficient and the density is constant for any given material.

This ratio μ/ρ measures the absorption due to unit mass of the absorbing medium taken over *unit* cross-section when the radiation is incident normally.

It will readily be understood that this ratio μ/ρ is more important than the simple linear absorption coefficient and is therefore very commonly employed; it is not to be imagined, however, that for all the elements the coefficient μ is simply proportional to the density, for in that case μ/ρ would be a constant which was independent of the nature of the material. This is not the case, for this ratio actually depends both on the atomic weight and on the quality of the radiation.

Sometimes the absorption is given in terms of the thickness D of the substance which halves the intensity of the radiation considered. It is easy to show that D and μ are connected by

the simple relationship $D = 0.69/\mu$, so that the coefficient μ is the reciprocal of a length.

For fatty tissues μ varies from 0.4 (hard rays) to 0.7 (rays of medium hardness); a centimetre of flesh absorbs from 30 to 90 per cent. of X-rays.

*Some Values of μ/ρ for Various Metals and for Different Frequencies **

λ in Ångström.	Fe $Z = 26.$	Cu $Z = 29.$	Mo $Z = 42.$	Ag $Z = 47.$	Pb $Z = 82.$
	$\rho = 7.86.$	$\rho = 8.93.$	$\rho = 9.1.$	$\rho = 10.5.$	$\rho = 11.37.$
0.100	0.265	0.323	—	1.13	3.78
0.110	0.399	0.49	1.35	1.67	4.32
0.120	0.572	0.77	1.96	2.63	2.0
0.250	1.07	1.53	4.02	5.75	4.62
0.300	3.18	4.47	12.7	18	13.9
0.400	7.17	10.1	26.7	38.4	32.7
0.500	14.3	18.8	48.6	11.0	59.3
0.600	23.3	31.6	80.7	18.7	91
0.700	36.3	49.2	18.8	25.6	133
0.800	51.7	—	27.2	—	—
0.900	69.6	97	37.5	57	140
1.000	95	133	51	75	177

Discontinuity K.

Discontinuity L.

The thickness $D_{1/10}$ of metal which transmits only one-tenth of the monochromatic radiation for which the absorption coefficient is μ is given by $D_{1/10} = 2.303/\mu$, and the thickness which absorbs half the radiation is found by multiplying this value $D_{1/10}$ by 0.301.

The energy lost by a beam of rays in passing through a body is partly scattered. The intensity of this scattered radiation is different in different directions, but it is of the same kind as the incident radiation (Compton effect). Another part of the absorbed radiation is changed in quality and is equally distributed in all directions (characteristic fluorescent radiation); finally, part of

* "Les Rayons α ," by Thibaud, 1930.

the energy is re-emitted in the form of *corpuseular* radiation (electrons), and very little of this leaves the body unless it is a gas; in the case of a gas, however, a considerable amount of ionisation takes place. The X-rays which are emitted are, in their turn, absorbed in a similar manner to the incident rays. The characteristic fluorescent radiations are those of the spectral lines given by the substance on which the radiation impinges, and their frequencies are always less than the frequency of the primary radiation.*

Since the corpuseular radiation is associated with the characteristic fluorescent radiation, the mass-absorption coefficient μ/ρ may be divided into two parts, one, σ/ρ , the mass scattering coefficient, and the other, τ/ρ , the transformation coefficient; hence we write :

$$\frac{\mu}{\rho} = \frac{\sigma}{\rho} + \frac{\tau}{\rho}$$

For the reason already stated, all three are referred to unit of mass. The relative proportions of the two kinds of absorption, scattering and fluorescence, depend on the nature of the substance and quality of the radiation.

In the case of aluminium, for instance, σ/ρ is about 0.15, but it may fall to 0.04 for very penetrating γ -rays.

The absorption responsible for the fluorescent radiation is, then, much more important, and in fact for certain elements, such as copper, τ/ρ is the same as the total absorption coefficient μ/ρ . The energy thus absorbed from the primary beam is

* The fluorescent rays are caused by the ionisation and subsequent recombination of the atoms of the radiator. As we shall see later (Vol. II, Chaps. II and V), when X-rays pass through a body, one part of their energy is expended in releasing β particles (electrons), and the remainder of the atom concerned (the ion), when it recombines with an electron, and so returns to its normal condition, gives out energy, which appears in the form of this fluorescent radiation. Since the ionised atom returns to its normal state in jumps, each of these corresponds proportionately to the emission of a monochromatic radiation, so that the fluorescent radiations are of a lower frequency than the primary radiation. We have said "proportionately"; this is Bohr's fundamental law, which we shall discuss at length in Vol. II, Chap. II. At present we shall only say that the energy levels between the successive jumps are called *stationary states of the atom*. The release of the electrons is known as the *photoelectric effect*.

re-emitted in the form of characteristic X-rays in the series K, L, M, etc., and as corpuscular radiation composed of electrons. As regards the way in which τ/ρ varies with the atomic weight of an element and with the wave-length of the radiation, it is found that it increases rapidly with increase in both these quantities, as we shall explain a little later.

Fig. 81, which summarises what has been said, shows the fluorescent absorptions of an element ; the K, L and M absorption

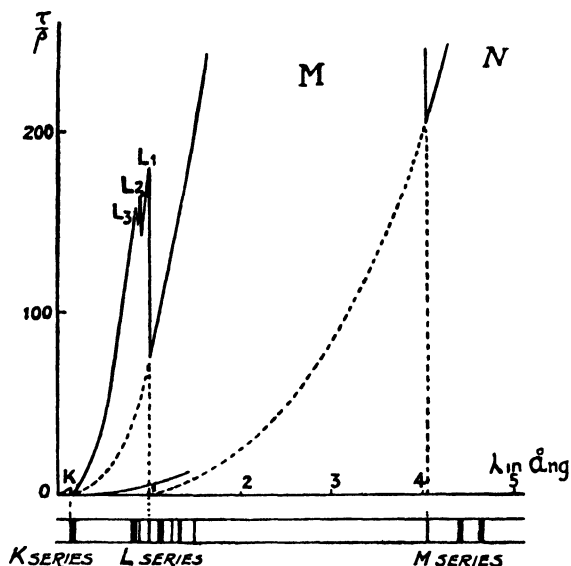

FIG. 81.

bands are shown, as well as the beginning of the N band ; these follow on in succession from the short wave-length end ; at the bottom of the diagram on the left is shown the absorption due to scattering, σ/ρ , which is negligible at high frequencies.

The maximum of the M band lies outside the diagram, being at least 1,000 times as great as that of the K band.

The discontinuous emission spectrum of the element is also shown for the purpose of indicating the close relationship between the fluorescence and the continuous absorption spectrum ; from this it follows that if the radiation reaching the element consists of long wave-lengths, the absorption is entirely due to the

excitation of M fluorescence. If λ becomes shorter, other absorption bands appear, and these produce the L fluorescence ; thus the total coefficient τ/ρ may be split up into its various components which are associated with the different bands of selective absorption.

This account will be made clearer by the description of the atomic structure given in Vol. II, Chap. II.

The elements have, then, a real *absorption spectrum* consisting of a series of bands which shifts in a regular manner from the short wave-length end and terminates in a sudden discontinuity at the other end (to the right). The wave-lengths of these discontinuities are slightly less than those corresponding to the highest frequencies in the emission spectra of the same body. It is the selective energy absorbed in a band which is partly re-emitted as the characteristic fluorescent radiation, while the remainder excites the electrons responsible for the corpuscular radiation.

Thus it is not only the cathode rays—*i.e.*, the rays consisting of very high speed particles—which can excite X-radiation ; the X-rays originating at the anti-cathode, if they strike a metal, can themselves cause the emission of undulatory radiations, and these have the great advantage over the primary radiation that they are *homogeneous*, since their quality is governed by the nature of the metal emitting them and not by the quality of the radiation which excites them ; the sole condition for their emission is that the primary rays shall be sufficiently hard. Further, since the penetrating power of a characteristic radiation increases with the atomic weight of the atom which emits it, it follows that the characteristic radiation of any given body can excite the corresponding radiation of any body which is lighter, but not that of a body with a higher atomic weight.

If, instead of considering a single element, a number of different elements be compared as regards the way in which the position of any one discontinuity varies with the atomic weight, the result will be Moseley's law, *viz.*, $\sqrt{\nu}$ increases directly as the atomic number.

But this is not the only rule which is found to hold among

the values of λ corresponding to the absorption limits for the different elements. There is a connection between λ and the quantity μ/ρ for a single element, and this shows how μ/ρ depends on the atomic number Z as we shall now explain.

To a first approximation it is found that

$$\frac{\mu}{\rho} = \frac{\sigma}{\rho} + k\lambda^3,$$

i.e., τ/ρ is roughly proportional to the cube of the wave-length.*

It is, however, to be noted that this empirical approximate relationship between μ/ρ and the cube of λ holds only for a certain range of wave-lengths ; when λ has fallen below the limit of this range, the absorption *suddenly* rises, it being understood that the same body is under consideration throughout.

In order to trace out the spectral absorption curve of a substance, the heterogeneous radiation given by an X-ray tube is filtered by reflection from a calcite crystal so as to produce an almost monochromatic beam in the path of which is placed a sheet of the substance being investigated. The ratio I_x/I_0 is then measured for different positions of the crystal, *i.e.*, for different wave-lengths.

By using different elements and different values of λ a complete picture of the phenomenon may thus be obtained.

In order to compare the scattering coefficients of the different elements, a quantity called the atomic coefficient of absorption τ_{at} is defined ; this represents the energy absorbed in the medium, per second, by a layer containing one atom per cubic cm. If N denotes Avogadro's number and A the atomic weight of the absorbing material, then

$$\tau_{at} = (\tau/\rho) (A/N).$$

The researches of Bragg and Pierce (1914), confirmed by many other experimenters, have given rise to the well-known formula which bears their name, viz.

$$\tau_{at} = \frac{\tau}{\rho} \cdot \frac{A}{N} = CZ^4\lambda^3$$

* F. K. Richtmyer, *Phys. Rev.*, 18, p. 13, 1921. S. J. M. Allen, *Phys. Rev.*, 27, p. 266, 1926.

This law expresses the well-known fact that the absorption decreases rapidly at the shorter wave-lengths.

It may be noticed that, A being roughly proportional to Z , it follows that τ/ρ varies approximately as Z^3 . Thus, if the variation of $(\tau/\rho)A$ with the atomic number be graphed for any given wave-length, the curve obtained is of the same form as if $(\tau/\rho)A$ be plotted against λ for any given element.

Now these researches have shown one essential fact, viz., the sudden changes which occur in the coefficient C ; at certain well-defined values of λ the curve representing the absorption τ shows an unexpected drop, after which it resumes its upward trend, but with a different value of C ; in the absorption curve of any one element there are several discontinuities corresponding to the *critical wave-lengths*, and these are called the *absorption discontinuities* of the element under consideration.

As we shall see in what follows, these wave-lengths λ_K, λ_L , etc., correspond to the frequencies $\nu_K = c/\lambda_K, \nu_L = c/\lambda_L$, at which a radiation falling on the substance tears away from the atom the constituent electrons in the various energy levels, each energy level thus corresponding to a discontinuity in the curve.

When ν reaches a critical frequency, ν_L for instance, an extra absorption due to the ionisation of the L ring takes place; this is the basis of a method of investigating the progressive building-up of the atoms which occupy successive positions in the periodic table.

As we shall see in Vol. II, Chap. II, the K discontinuity is single, L is triple, and M is a quintet.

The law of Bragg and Pierce, then, only expresses the variation of τ_{at} between two successive discontinuities; in order to obtain the total absorption for a radiation of frequency ν it is necessary to add all the terms $CZ^4\lambda^3$ for which Z and λ are constants, while C assumes first one value C_K , then another C_L, C_M , and so on.

The values, according to Richtmyer, for the mass-coefficients τ/ρ for certain elements are as follows:—

ρ				
8·98	copper	for λ between 0·1 and 0·6Å		$\mu/\rho = 147\lambda^3 + 0·5$
9·1	molybdenum	„ „ 0·1 „ 0·35Å		$\mu/\rho = 450\lambda^3 + 0·4$
2·70	aluminium	„ „ 0·1 „ 0·4Å		$\mu/\rho = 14·45\lambda^3 + 0·15$

Wave-lengths in Ångströms of the Discontinuities K, L_I, L_{II}, L_{III} for certain Elements

	Atomic Number.	K.	L _I .	L _{II} .	L _{III} .
Silver . .	47	0·4850	3·2605	3·5047	3·6844
Platinum . .	78	0·1581	0·8921	0·9321	1·0704
Bismuth . .	83	0·1371	0·7565	0·7874	0·9216
Uranium . .	92	0·1075	0·5685	0·5918	0·7214

Practical Applications of X-rays

We shall devote only a few words to this subject, as it lies outside the plan of this book and, further, the author is not qualified to deal with the therapeutic side of the work.

We may first mention *radiography*, or the taking of photographs through the human body in which the bones—which contain relatively heavy elements such as phosphorus and calcium—are more opaque to the X-rays than the flesh, which consists of lighter elements (hydrogen, carbon, nitrogen, oxygen). If part of the human body is placed between the source of the rays and a screen of barium platinocyanide, the shadows cast by the bones on the screen are denser than those cast by the flesh; this is the principle of the radioscope.

Radiology has given remarkable assistance in the diagnosis of disease or in the showing of the effects of accidents affecting the internal parts of the body; thus it not only shows up foreign objects in the body, but it reveals the existence (or the absence) of fractures, or the result of a setting.

In an institution for the treatment of rickets, for example, radiography is all-important.

In modern dentistry, the teeth are examined before they are treated.

Certain diseases are treated with Röntgen rays: lupus, surface cancer, fibromata, etc.

To examine the performance of the digestive organs, radiographs are taken by introducing into the patient's food a bismuth salt

or barium sulphate which renders it more opaque so that it can be followed during the course of its passage through the stomach and the intestines. The various internal organs of the body (liver, bladder, etc.) can be observed so as to obtain a knowledge of their disorders.

Stereoscopic radiography consists in taking photographs with the tube in two different positions, and by this means it is possible to determine the depth of the object being examined below the surface of the body in which it is embedded.

In July 1928, on the occasion of the Congress of Radiology at Stockholm, an international agreement was reached on the unit to be used for measurements in radiology so that the results obtained by different experimenters might be made comparable.

The *quality* of the radiation in the practically useful range (either medical or metallurgical) is defined by means of the coefficient of absorption in copper or in aluminium, and the value of the maximum potential applied to the tube.

The *quantity* is measured, as has already been explained, on the basis of the ionisation produced in air; the unit quantity of X-rays is that which produces in one cubic centimetre of air under normal conditions one electrostatic unit of electricity. This quantity is called the "*Röntgen*."

The importance of this agreement arises from the fact that every action of the rays on the tissues obviously depends on the quantity of energy absorbed by these tissues, and the X-rays may produce either a *favourable* or a *destructive* action according to the dose administered. Further, the quality of the rays to be used depends on the depth to be reached in their application.

Without going into details we may remark that X-rays undoubtedly produce good results in superficial and certain other forms of cancer, if applied sufficiently soon; there are other forms of cancer (sarcoma) which do not seem to be affected; the most important advantages of X-rays are unquestionably still as an aid in diagnosis.

As regards industrial applications, a new technique, that of radiometallography, has been developed within the last few years. By this means it is now possible to detect and to photograph

defects within a body such as a metal plate, a machine part, or tubes intended to withstand high pressures ; an autogenous weld may also be examined for faults. The variety of ways in which these rays may be used for examination of the internal parts of different bodies will be understood when it is realised that it is possible to penetrate 5 mm. of lead, 7 cm. of steel, 15 cm. of aluminium and 40 cm. of wood.

There is a vast field of usefulness for X-rays in the analysis and control of metals and alloys, for by such means it is possible to determine the crystal form in an ingot and to follow the effects of heat treatment or mechanical treatment on a given specimen. The metal to be examined should, for this purpose, be used in the form of a plate which is sufficiently thin so as not to have too great an absorption. In this way it is possible to study metals such as iron, and alloys such as cobalt, nickel manganese or other steels, bronzes, brass, duralumin, etc. To give a general idea of the problem we may remark that among steels there are various components such as *austenite*, *ferrite*, *martensite*, etc., each of which has its own crystalline form determined by means of radiographs, as we shall explain in the next chapter.

Other objects which are examined in the same way are porcelain insulators, carbon electrodes for arc lamps (to determine their homogeneity), the wooden laminæ in aeroplane screw-propellers, etc.

The time of exposure necessary for this kind of work has been reduced as the technique has developed ; for a carbon steel plate 25 cm. thick, one minute's exposure is required, using a voltage of 130,000 volts.

X-rays are now used with success in the examination of alloys and of steels in order to investigate the dimensions and nature of the crystal structures of their components.

They are employed to detect artificial pearls, to analyse the smallest of crystals, to examine the fibrous structure of vegetable substances, to test coal, to detect retouched portions of old paintings, etc., etc.

Anyone who wishes to learn more about the application of X-rays in testing materials should consult R. Glocker's book,

“Materialprüfung mit Roentgenstrahlen,” or the more recent book by J. H. Trillat entitled “Les applications des Rayons X.”

Among the Italian experts in the use of X-rays, whether for medical or industrial purposes, we may mention the engineer Enzo Pugno Vanoni of Milan.

BIBLIOGRAPHY

- E. N. DA C. ANDRADE. “The Structure of the Atom” (1927).
 J. THIBAUD. “Les Rayons X” (1930).
 A. SOMMERFELD. “Atombau und Spektrallinien” (1924).
 W. H. and W. L. BRAGG. “X-rays and Crystal Structure” (1925).
 M. SIEGBAHN. “Spektroskopie der Roentgenstrahlen” (1924). (English translation by G. A. Lindsay.)
 M. DE BROGLIE. “Les Rayons X” (1922).
 R. LEDOUX-LEBARD and A. DAUVILLIER. “La Physique des Rayons X” (1921).
 H. MARK. “Die Verwendung der Roentgenstrahlen in Chemie und Technik” (1926).
 H. G. J. MOSELEY. “The High-frequency Spectra of the Elements,” *Phil. Mag.*, 26, p. 1024, 1913; 27, p. 703, 1914.
 G. W. C. KAYE. “Practical Applications of X-rays” (1922).
 C. G. DARWIN. “The Theory of X-ray Reflection,” *Phil. Mag.*, 27, pp. 315 and 675, 1914.
 A. DAUVILLIER. “La Technique des Rayons X” (1924).
 N. BOHR and D. COSTER. “Roentgenspektren und periodisches System der Elemente,” *Zeit. f. Phys.*, 12, p. 342, 1923.
 A. H. COMPTON. “X-rays and Electrons” (1928).
 E. C. STONER. “X-ray Term Values, Absorption Limits and Critical Potentials,” *Phil. Mag.*, 2, p. 97, 1926.
 G. L. CLARK. “Applied X-rays” (1927).
 F. K. RICHTMYER. “Introduction to Modern Physics” (1928).
 TERRIL. “X-ray Technology” (1930).

may happen that the incident rays AB , $A'B'$, $A''B''$, $A'''B'''$ are reflected along the same path BC and they are all in the same phase; this will occur for a certain selected direction θ such that $2d \sin \theta = \lambda$. Actually the difference of path between two reflected rays is $(MB' + BB') - MN$, and since $MB' = BB' = d/\sin \theta$ and $MN = (2d/\sin \theta) \cos^2 \theta$, it follows that

$$MB' + BB' - MN = (2d/\sin \theta) (1 - \cos^2 \theta) = 2d \sin \theta.$$

It will be seen that the reflection brings into play the lower layers from the first downwards. For another suitable angle which gives rise to a difference of path equal to two wave-lengths, the reflected rays are again superposed in phase, and so, generally, a reflected beam is produced at the various angles satisfying the equations

$$2d \sin \theta_1 = \lambda, \quad 2d \sin \theta_2 = 2\lambda, \quad 2d \sin \theta_3 = 3\lambda, \text{ etc.}$$

If, then, the incident X-rays are not monochromatic, the result will be a spectrum, since the crystal will sort out the various frequencies and reflect them each in a different direction. Let us confine our attention to the first order spectrum which corresponds to the condition $2d \sin \theta = \lambda$; for every wave-length there is an angle of reflection θ . From this equation it will be understood that it is possible to obtain the value of the wave-length when the constant d of the crystal is known (or *vice versa*), d being the distance between two successive planes of the lattice; it is necessary to have an instrument by which to measure the angle θ . This is of the greatest importance.

If, then, a crystal face be so placed that a beam of X-rays restricted by a narrow slit is incident upon it at an angle which can be varied continuously—this may be arranged by rotating the crystal—the reflected beam at each angle of incidence will consist of a homogeneous pencil of rays of definite wave-length.

If, further, the reflected rays be caused to strike a photographic plate, a series of images of the slit will be recorded, each produced by radiation of a definite wave-length, exactly in the same way as a spectrum is obtained with a prism when using white light.

In this manner the wave-lengths of X-rays have been measured and found to be of the order of one Ångström.

It is to be noted that the reflection of the X-rays is independent of the existence of specular faces at the boundary of the crystal ; it depends only on the internal orientation of the atomic planes and on their spacing.

This difference between the phenomenon termed "X-ray reflection" and the reflection of ordinary light at polished surfaces is fundamental. The elements of the crystal structure are so small that, although under X-rays they act as separate and discrete particles, they behave as a continuous medium towards luminous rays the wave-length of which is great compared with the interval between the elements of a crystal. The X-rays, in any case, do not usually penetrate a crystal for more than a few millimetres.

A train of monochromatic waves falling on a face is reflected, as stated above, only if the angle θ has certain definite values satisfying the equations $2d \sin \theta_1 = \lambda$, $2d \sin \theta_2 = 2\lambda$, etc.

The reflection corresponding to θ_1 is the first order reflection. It is clear that by using the same reflecting face, it is possible to compare the wave-lengths of the monochromatic vibrations by reading off the angles θ_1 and using the relation $2d \sin \theta_1 = \lambda$; if, however, a single frequency be employed, it is possible to compare the distances between the reflecting planes of the lattice, either of a single crystal or of different crystals. This simple theory may thus be applied to two types of investigation. For instance, Bragg, using reflection from a plate of sodium chloride cut parallel to the face of the cube, found that the reflected radiation was particularly intense at the angles 5.9° , 11.85° and 18.15° , using the radiation from a palladium anticathode. The distance d between the atomic planes parallel to the faces of the cube in the case of rock-salt was available to Bragg, since the constitution of sodium chloride was known ; he was thus able to deduce λ .

Consider Fig. 83. It is clear that in a crystal of this kind the number of elementary cubes is equal to the number of atoms, and this is double the number of molecules ; if, then, M denotes the molecular weight of sodium chloride (which is known to be 59.50) and ρ the density (which is 2.17), M/ρ is the volume of the

gramme-molecule ; $M/\rho N$ is therefore the volume occupied by a molecule where N is Avogadro's number.

The volume of the elementary cube is d^3 , and from what has just been said,

$$d^3 = M/2N\rho,$$

so that we find

$$d = \sqrt[3]{\frac{59.50}{2 \times 60.6 \times 10^{22} \times 2.17}} = 2.81 \times 10^{-8} \text{ cm.}$$

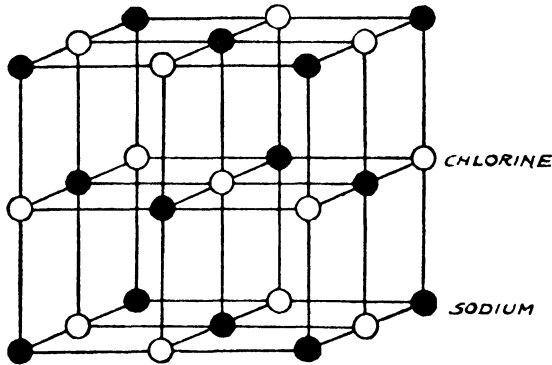

FIG. 83.—The space-lattice of sodium chloride and of the halides of the alkali metals.

This gives the lattice spacing which is of such importance in the study of crystal structure and in its applications.

Putting this value in the fundamental expression $2d \sin \theta = \lambda$, Bragg found the wave-length of this monochromatic radiation from palladium ; the three angles corresponded to the reflection bands of the first, second and third orders, since their sines were in the ratios 1 : 2 : 3. The smallest of the three angles gave

$$\begin{aligned} \lambda &= 2d \sin \theta = 2 \times 2.81 \times 10^{-8} \times \sin 6.9^\circ \\ &= 0.576 \times 10^{-8} \text{ cm.} \end{aligned}$$

Using this extremely important method of diffraction from crystals, it was possible to measure wave-lengths from 50 to 50,000 X-units (one X-unit = 10^{-11} cm.).

The complementary process is, as has been said, the determination of the distance between two atomic planes in a crystal. First

of all it is easy to determine the directions of the atomic planes by means of a photograph obtained by Laue's method ; in order to find the distance between the parallel planes, it is necessary to measure the deviation of a ray of known wave-length, e.g., the $\text{L}\alpha_1$ ray of tungsten for which $\lambda = 1.4735$ Ångström. The value of d is obtained from the fundamental formula by measuring the angles with an ionisation chamber spectrometer, which we shall describe on page 260.

Experiments have shown that Bragg's law $n\lambda = 2d \sin \theta$ is only approximate ; Darwin and Ewald have put forward a theory which depends on the fact that the index of refraction μ of the crystal for X-rays, although it is very nearly unity, differs from that value by a small quantity δ which is given by the equation :

$$\text{Drude and Lorentz formula.} \quad \delta = 1 - \mu = \frac{e^2}{2\pi m} \sum \frac{\mathcal{N}_i}{\nu^2 - \nu_i^2}$$

where the values of ν_i are the natural frequencies of the resonators (the electrons) set in oscillation by incident radiation of frequency ν , while the values of \mathcal{N}_i are the numbers of electrons at the various levels K, L, M for unit volume of the substance.

We have already come across this expression on page 46.

If, therefore, the ray is deviated slightly as it enters the crystal, the simple treatment based on Fig. 82 can no longer be applied rigorously, and hence the simple law due to Bragg is no longer absolutely accurate but must contain another function of λ .

Actually, the natural frequencies of the atom are negligible compared with that of the incident radiation, so that

$$\delta = 1 - \mu = \frac{e^2 \mathcal{N}}{2 \pi m \nu^2}$$

On this basis, Darwin and Ewald have shown that Bragg's formula must be amended to the following exact form

$$n\lambda = 2d \sin \theta \left[1 - \frac{4 \delta d^2}{n^2 \lambda^2} \right]$$

and hence

$$n\lambda = 2d \sin \theta \left[1 - \frac{4d^2 \mathcal{N}_e^2}{n^2 \cdot 2\pi m c^2} \right]$$

where $c = \nu\lambda$ is the velocity of light and m and e are the mass and elementary charge of the electron.

If the known values of e , m and c be inserted in this formula, and \mathcal{N} be put equal to the *density* of the material, the resulting formula may be used in practical work.

E. Hjalmar has made precise measurements which have provided experimental verification for this result ; later and very accurate work has been carried out by Larsson (1915 and 1926).*

For *hard* X-rays, δ is of the order of 10^{-6} , so that the index of refraction is exceedingly close to unity and the resulting refraction practically negligible ; on the other hand, for *soft* X-rays δ assumes values of the order of 10^{-2} and the difference from Bragg's expression becomes marked.

The Braggs' Spectrometer—Brief outline of their Work on Crystal Structure

Bragg's method—called the ionisation chamber method—consists in detecting the reflected beam of X-rays by means of the ionisation it produces in a gas which is enclosed within a chamber and which is subjected to an electric field so that all the ions formed are collected.

Fig. 84 shows the arrangement of the spectrometer and the tube producing the Röntgen rays ; the crystal at C is fixed by means of wax to a rotating platform ; the pointer L indicates the angle of rotation, the relative positions of the crystal and the ionisation chamber remaining unaltered ; F, F are two apertures through which the rays pass on their way to the crystal ; the rays reflected at certain angles enter the ionisation chamber B. This usually contains sulphur dioxide, which absorbs X-rays very readily ; it is carefully insulated and is brought to a high potential. The electrode is placed close to the window by which the X-rays enter B, and it is connected to an electroscope ; the X-rays entering the chamber release electrons from the atoms, and these collide with the gas molecules and produce ions of both signs so that the gas becomes a conductor.

* C. G. Darwin, *Phil. Mag.*, 27, p. 315, 1914. P. P. Ewald, *Ann. d. Phys.*, 54, p. 519, 1917. E. Hjalmar, *Zeits. f. Phys.*, 15, p. 65, 1923. A. Larsson, *Zeits. f. Phys.*, 35, p. 401, 1926 ; 41, p. 507, 1927.

It was with an instrument of this kind that W. H. Bragg and his son carried out the remarkable researches which have made their names world-renowned. Each has attributed to the other the credit for these wonderful researches which have given us a knowledge of the way in which crystals are built up atom by atom.

In two years they completed the analysis of a large number of crystalline structures, giving not only the exact relative positions of all the atoms in the lattice, but the absolute dimensions as well. After them many others continued and are continuing their work, *e.g.*, Moseley, Duane, Compton, Hull, Maurice de

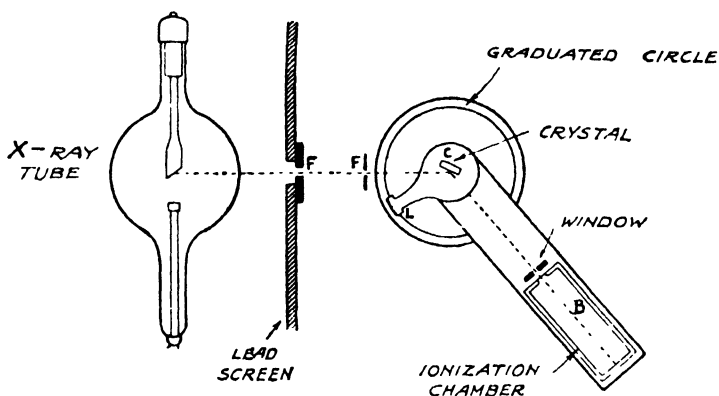

FIG. 84.—Spectrometer with ionization chamber.

Broglie; the last named physicist has used a spectrometer in which a circular film is employed to obtain a photographic record of the reflected beam (Fig. 85). If the angular range of this beam in any given experiment be small (not greater than 15°), a flat plate may be used in place of the film as shown in Fig. 86. The framework carrying the crystal may be rotated at uniform speed by means of clockwork or an electric motor very much geared down.

Fig. 86 shows the experimental arrangements in diagrammatic form; K is the cathode of the X-ray tube, A is the anticathode, S_1 , S_2 are two delimiting apertures in a lead box, T is the goniometer table which carries the crystal; as this rotates through an angle δ , the reflected ray, as is well known, moves through an angle 2δ and strikes either the film FF or the plate PP.

Among other things, Bragg measured the intensity of the X-radiation emitted by different anticathodes and with different

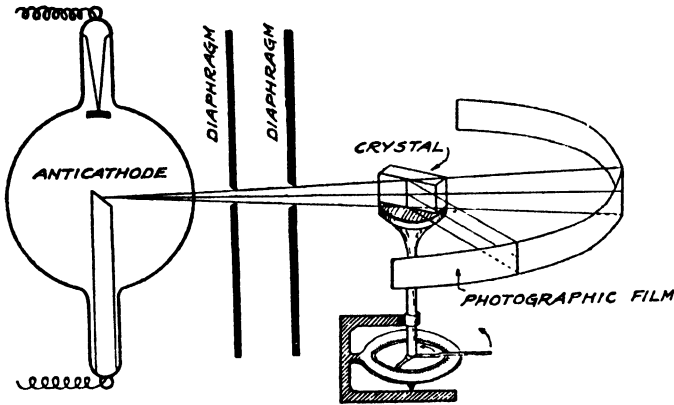

FIG. 85.—Apparatus used by Bragg and de Broglie.

potentials applied to the tube, basing his measurements on the intensity of the ionisation currents. We cannot deal with this

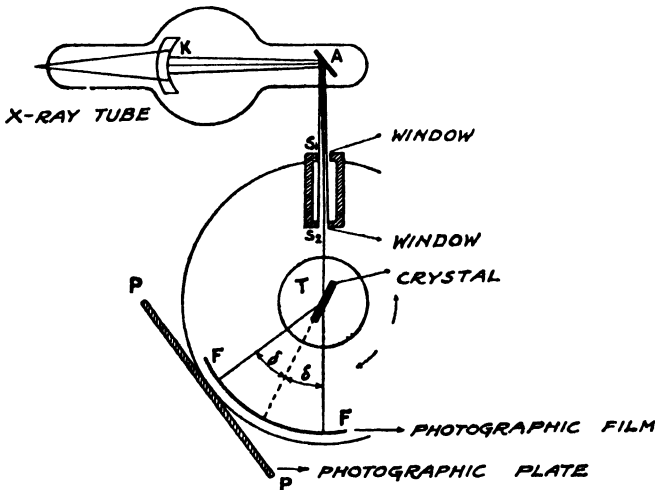

FIG. 86.

in detail, and can only state that the total energy emitted is divided between a continuous spectrum and sharp lines characteristic of the metal of which the anticathode is made ;

this fact had already been demonstrated by another physicist, Barkla, who used in his work the X-ray absorption factors of various substances ; by this absorption method he obtained a rough analysis of the radiation into its monochromatic components.

We can now give a brief outline of some of the results obtained in the well-known work carried out by the Braggs. Let us take first of all the case of rock-salt, which belongs, as is well known, to the cubic system ; the space lattice arrangements possible in a cubic symmetrical arrangement are of three kinds : the *simple cubic lattice*, the *centred cubic lattice*, and finally, the *face-centred cubic lattice*, in which, as will be seen from the figure, four masses are situated at the corners of a regular tetrahedron. There is a ready means of determining which of these three lattices corresponds to the arrangement of the atoms in rock-salt. Consider the three following systems of atomic planes which can be drawn in the crystal :

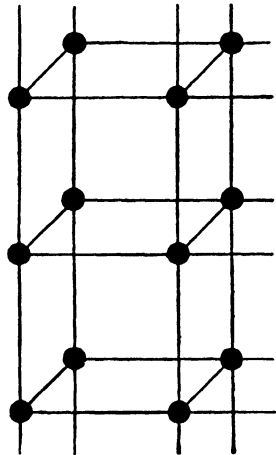

FIG. 87.—The simple cubic lattice.

(i.) the face of the cube, 100.

(ii.) the face of the rhombodecahedron 110, which is the diagonal face of the cube and which is parallel to one of the three axes and makes equal intercepts on the others.

(iii.) the face 111 of the octahedron which is so placed as to be equally inclined to the axes of reference.

Now a careful inspection of Fig. 89 shows that the distances between two parallel planes in the case of the three systems of planes above described are respectively

$$a \quad a/\sqrt{2} \quad 2a/\sqrt{3}.$$

Hence these three lattice distances should bear to each other the ratios

$$1 : 1/\sqrt{2} : 2/\sqrt{3}.$$

This is exactly what is found when a given monochromatic radiation is reflected from these three systems of planes.

If, however, the space-lattice of rock-salt were the simple cube or the centred cube, the three distances appropriate to the planes 100, 110 and 111 would not be in the above ratios; actually in the case of the simple cube the ratios would be $1 : 1/\sqrt{2} : 1/\sqrt{3}$ and in the case of the centred cube $1 : \sqrt{2} : 1/\sqrt{3}$.

The same result is obtained experimentally for all the halides of the alkali metals, *i.e.*, for the chlorides, bromides, fluorides and iodides of sodium, lithium and potassium, with *the single exception of potassium chloride*. For this salt the distances between the atomic planes referred to above bear to one another the ratios $1 : 1/\sqrt{2} : 2/\sqrt{3}$ which belong to the simple cubic lattice.

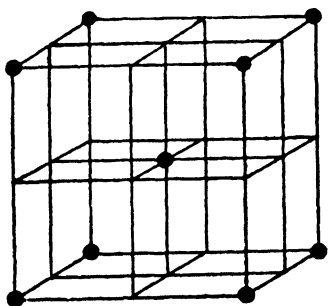

FIG. 88.—The centred cubic lattice.

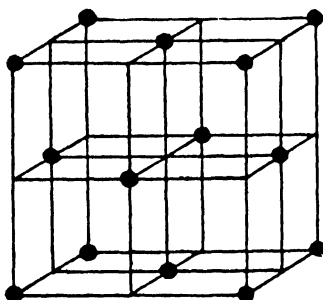

FIG. 89.—The face-centred cubic lattice.

The measurements made by Bragg on a crystal of sylvine (KCl) gave for the semi-deviations produced by the three sets of atomic planes on a single palladium line the following values :

$$5.22^\circ, 7.30^\circ, 9.05^\circ.$$

Referring back to the fundamental equation $2 \sin \frac{1}{2} \delta = \frac{1}{2} \lambda$,* it will be seen that the sines of these angles bear to one another the ratios $1 : \sqrt{2} : \sqrt{3}$ and these give values for the ratios of $d_1 : d_2 : d_3$, which are appropriate to the simple cubic lattice.

This result is, however, deceptive; potassium chloride, which is so closely akin to sodium chloride, should not be exceptional. What is the reason for this apparent anomaly? Simply the

* δ is the deviation which the incident beam undergoes.

fact that the two atoms of the KCl molecule have neighbouring atomic numbers, the former occupying the 17th place and the latter the 19th place in the periodic system. Now, as we shall explain later (p. 339), equality of atomic number is concomitant with equality in the number of electrons in the outer ring of the atomic system, and it is these electrons which are responsible for the diffusing power of the atom; actually the atoms of chlorine and potassium have exactly the same number of electrons in the outer ring, viz., eighteen. It may be stated, therefore, that the structure of potassium chloride is the same as that of rock-salt, although it appears as if it were a simple cubic structure of half the dimensions.

It has been found possible, by similar methods, to determine a large number of crystal structures. Only a few substances, however, yield crystals which are large enough to enable the experiment to be performed; in most cases the crystals are very small.

Fortunately another method has been devised by Debye and Scherrer. In this the experiment is carried out with powder, that is to say, very small crystals; we shall describe it a little later on.

This important method is less convenient than the rotating crystal method in that it requires a long exposure in order to obtain a photographic record, but on the other hand it has the great advantage—apart from the fact that no crystals are needed—of demonstrating the crystalline structure of substances which crystallography had not supposed crystalline because the crystals were so very

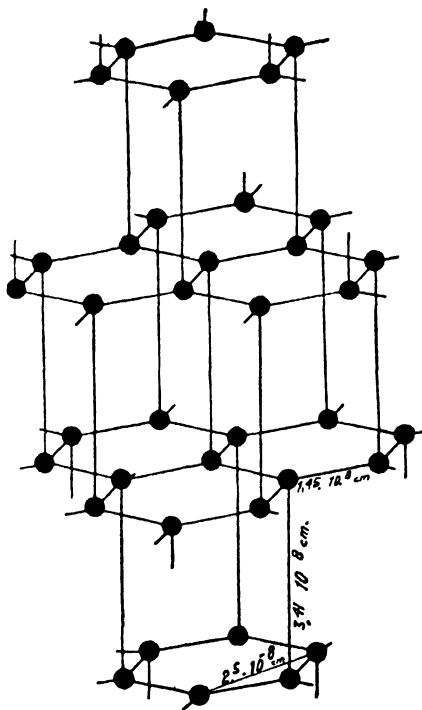

FIG. 90.—The space lattice of graphite.

small ; the result has been to show that practically every mineral is crystalline.

The following are further examples of crystal structures : for metals the most common form is the face-centred cube ; such are aluminium, cobalt, nickel, copper, silver, etc.

Examples of Crystal Structures among the Elements

Face-centred Cube

Element.	Side of Cube (Ångström).	Element.	Side of Cube (Ångström).
Aluminium . . .	4·043	γ-Iron . . .	3·63
Cobalt	3·554	Silver	4·079
Nickel	3·499	Platinum	3·913
Copper	3·603	Lead	4·920

Centred Cube

Element.	Side of Cube (Ångström).	Element.	Side of Cube (Ångström).
Lithium	3·50	Chromium	2·875
Sodium	4·30	α-Iron	2·855
Potassium	5·20	Molybdenum	3·143

Other metals belong to the hexagonal system ; such are magnesium, cadmium and zinc.

Lithium, sodium, potassium and chromium are of the centred-cube type.

Fig. 90 shows the lattice structure of graphite. The three dimensions which govern the form of the structure are shown in the figure. It will easily be understood why graphite shows such a large difference between the compressibilities in the direction of stratification and a direction perpendicular to this.

The *lattice structure of fluor-spar* (CaF_2) is shown in Fig. 91.

It was Bragg who discovered that in a crystal the atoms may

be looked upon as similar to spheres in contact, the radius of these spheres being practically constant ; we know already that the atoms of all the elements have dimensions of the order of 10^{-8} cm. ; now the units in the crystal lattices are of just the same order of size and these two facts taken together prove the truth of the statement made above.

For the sake of simplicity we shall not give a detailed description of the method used by Bragg to demonstrate that the lattice behaves as a collection of spheres which are packed close to one another, their centres being situated at what we have referred to so far as the points of the lattice ; the essential fact established by Bragg is that

each sphere has a definite diameter for any given element and that this diameter is the same whatever be the crystal in which the element occurs ; in virtue of this fact it is possible to find the distance between the centres of two neighbouring atoms in a crystal by simply adding their characteristic radii. This may be verified by studying, for instance, the structures of the crystals of ZnO, ZnS, BaO, BaS, MgO, MgS. By a comparison of the oxide and the sulphide of the same element, applied to the same lattice dimension, it is possible to find the difference between the diameter of the oxygen atom and that of the sulphur atom ; this difference is found to be constant and equal to 0.75×10^{-8} cm., so that the existence of spherical atoms in contact is confirmed.

As a particular example we may describe how this has been established in the case of pyrites (FeS_2).

It was known that iron gave a centred cubic lattice for which the side of the cube was 2.86×10^{-8} cm. and, on the assumption that the lattice was made up of spherical atoms in contact, it could at once be calculated that their diameter was 2.47×10^{-8} cm.

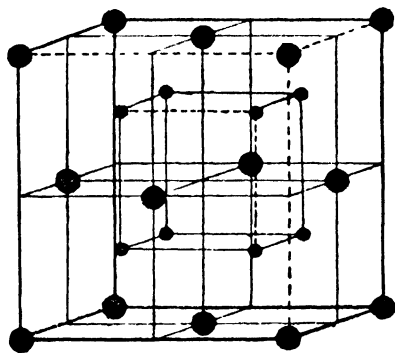

FIG. 91.—The space lattice of fluorite.

since this was the distance between the centres of two neighbouring atoms.

The structure of pyrites is that shown in Fig. 92, where it will be seen that the four Fe atoms are situated at the corners of a tetrahedron and that the two S atoms are on the diagonal of the cube; these two atoms are situated symmetrically with respect to the vertex O. The length of side of the cube is known; Bragg and others have found, by various methods, that the distance

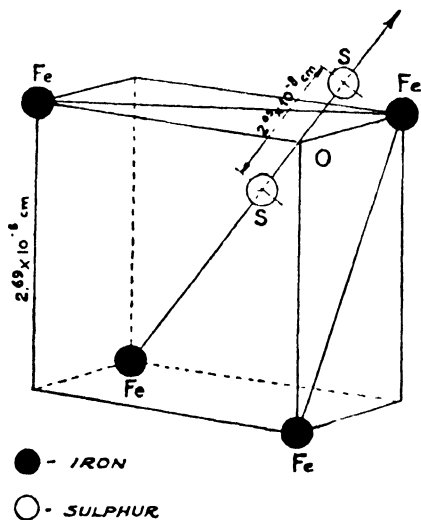

FIG. 92.—The space lattice of pyrites (FeS_2).

between the two atoms of sulphur is 2.05×10^{-8} cm. These distances being known, the figure can be constructed; it is supposed that the two atoms of sulphur are spheres in contact and that the Fe atoms expand until they touch each other and the S atoms; under these conditions it is found that the diameter of the Fe atoms has the value 2.47×10^{-8} cm., which is precisely the same as the value found directly.

In this way, then, it is possible to determine the diameters of the atoms.

The following values are due to Bragg :—

Radius of the Atom

Carbon	0.77×10^{-8} cm.
Nitrogen	0.65×10^{-8} „
Oxygen	0.65×10^{-8} „
Magnesium	0.42×10^{-8} „
Aluminium	1.35×10^{-8} „
Silicon	1.17×10^{-8} „
Silver	1.87×10^{-8} „

Debye and Scherrer's Method of Crystal Analysis

In 1916-17 Debye and Scherrer perfected a new method for the investigation of crystal structures.

In order to understand it properly we must first consider an elementary problem in plane geometry ; from this we can pass to the consideration of the three-dimensional problem by simple analogy.

Consider a network of points arranged in a rectangular pattern as shown in Fig. 93 ; the intervals a and b in the two principal directions are unequal.

If we draw the straight line OM, its equation is :

$$\frac{x}{a} - \frac{y}{b} = 0,$$

since this represents a straight line passing through the origin of coordinates and through the point whose abscissa is a and ordinate b . The straight line PN, parallel to OM, is represented by the equation :

$$\frac{x}{a} - \frac{y}{b} - 1 = 0,$$

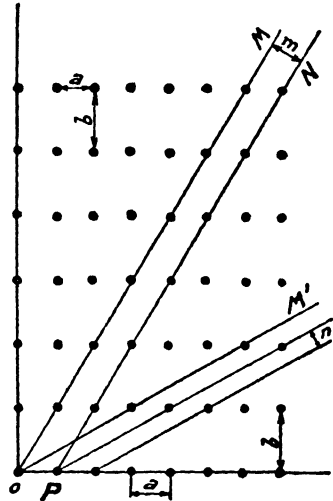

FIG. 93.

as may be shown quite easily. It will be seen, then, that a straight line OM' drawn from O to any point in the network will be represented by the equation :

$$h_1 \frac{x}{a} + h_2 \frac{y}{b} = 0,$$

where h_1 and h_2 are two integers.

This equation represents any one of the infinite number of lines which can be drawn through the points of the network.

From what has been stated above it will be clear that the line parallel with and next to a line passing through the origin and

any given set of collinear points will be represented by the equation :

$$h_1 \frac{x}{a} + h_2 \frac{y}{b} - 1 = 0.$$

The axes of co-ordinates are intersected at points which are respectively at the distances a/h_1 and b/h_2 from the origin. If the network were a *square* one, instead of rectangular, then a would be equal to b and the distance d between these two lines is easily shown to be

$$d = \frac{a}{\sqrt{h_1^2 + h_2^2}}.$$

We may now pass on to the consideration of a three-dimensional lattice composed of points arranged at the corners of contiguous cubes ; the straight lines drawn through the origin to intersect the points of the network now become planes ; the equation to these planes is exactly similar to that written above, and the distance between two successive parallel planes is given by :

$$d = \frac{a}{\sqrt{h_1^2 + h_2^2 + h_3^2}},$$

where h_1 , h_2 and h_3 are any three integral numbers.

These planes must be considered as including all those which it is possible to have inside a crystal, passing through the points of the crystal lattice ; they may all be represented by giving h_1 , h_2 and h_3 any three *integral* values whatever. We can now proceed at once to describe the principle of Debye and Scherrer's method.

Consider a mass of small regular crystals (*i.e.*, a powder) on which there is incident a beam of monochromatic X-rays. There is in these tiny crystals a plane which is defined by, we will suppose, the three integral numbers h_1 , h_2 and h_3 ; the parallel plane nearest to it is separated from it by a distance

$$d = \frac{a}{\sqrt{h_1^2 + h_2^2 + h_3^2}}$$

and all the other parallel planes occur at this same interval.

From what has been said in connection with Bragg's method it

will be clear that an incident beam of given wave-length will be reflected from this set of parallel planes if

$$\sin \theta = (\lambda/2a)\sqrt{h_1^2 + h_2^2 + h_3^2},$$

where a is the constant of the cubic lattice of the crystal and θ is the semi-deviation of the incident beam.

The orientation of the plane is unimportant since every plane in every crystal, for which the above equation is satisfied, will exhibit reflection at the angle θ . The reflected rays, therefore,

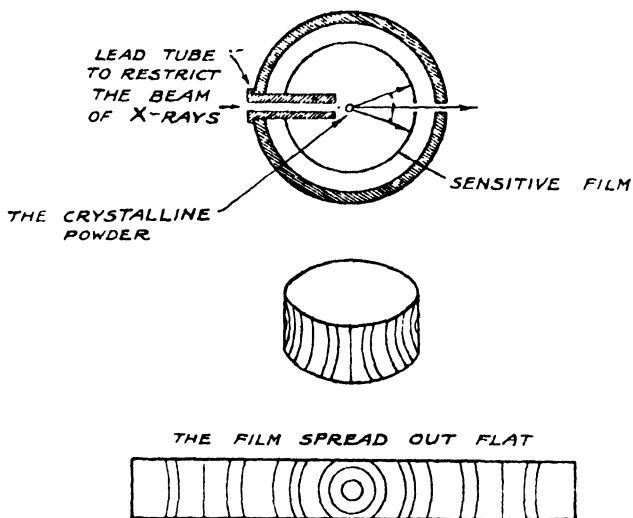

FIG. 94.—Scattering of X-rays by a crystalline powder.

are situated on a right circular cone, of vertical angle 2θ , the axis being in the direction of the incident rays.

The planes defined by three integral numbers h_1, h_2, h_3 are not the only ones which produce the effect; equally, all the planes which are represented by permuting these figures, or by changing the signs of one or more of them, give rise to the same deviation of the incident rays; if, for instance, h_1, h_2, h_3 are respectively 1, 3, 2, it will be clear that the planes (231), (213), (132), (123), etc. all give the same value of $\sqrt{h_1^2 + h_2^2 + h_3^2}$ and therefore of θ . In general there are altogether 48 such planes. This number is halved if two of the numbers are equal or if one of them is zero.

If, for any given radiation, measurement be made of the various semi-angles of the cones, θ , and if $\sin \theta$ be taken for each of these, the numbers obtained bear to one another commensurate ratios, since $\sin^2 \theta$ is proportional to $(h_1^2 + h_2^2 + h_3^2)$ and this is always an integral number.

If the X-radiation falling on a crystalline powder is not monochromatic but contains, say, two lines, then the cones no longer form one but two series.

The experimental arrangement used in this method is shown in the upper part of Fig. 94.

The substance to be studied (*e.g.*, graphite or lithium fluoride) is powdered and then mixed with collodion so as to give a small rod the size of a match. This rod is placed vertically in the centre of a cylindrical chamber about 60 mm. in diameter. The top of this chamber is covered with an opaque lid and in the wall is a hole about 2 mm. in diameter through which passes a tube of lead; the incident beam from an external X-ray tube passes through this tube into the chamber.

A photographic film is placed around the inside walls of the cylinder.

The time of exposure is of the order of three hours. When the cylindrical film is developed as a plane, the intersections of the various cones give arcs of ellipses arranged symmetrically about the trace of the undeviated beam. The vertical angles δ of these cones are measured and the values of $\sin \frac{1}{2}\delta$ are found. As an example the values found for lithium fluoride with X-rays from a copper anticathode may be cited.

The radiations used were two in number, viz. :

$$\lambda = 1.549 \times 10^{-8} \text{ cm.} \quad \lambda = 1.408 \times 10^{-8} \text{ cm.}$$

As will be seen, the two series give the same value for the side of the elementary cube in the lattice structure as should, of course, be the case.

As regards the formation of the triads h_1, h_2, h_3 it may be noted that it is sufficient to place the values of $\sin \frac{1}{2}\delta$ in ascending order and then the values of h_1, h_2, h_3 to be chosen will be immediately apparent.

	Angle of Cone (obs.)	$\text{Sin } \frac{\delta}{2}$	h_1	h_2	h_3	$\frac{\lambda}{2a} = \frac{\text{sin } \delta}{\sqrt{h_1^2 + h_2^2 + h_3^2}}$
1st series * with $\lambda =$ 1.549×10^{-8}	37.8°	0.323	1	1	1	0.187
	44.2°	0.377	2	0	0	0.189
	63.8°	0.528	2	2	0	0.187
	80.8°	0.647	2	2	2	0.187
Constant a of the lattice given by this is $a = 4.11 \times 10^{-8}$ cm.						
2nd series with $\lambda =$ 1.408×10^{-8}	33.8°	0.290	1	1	1	0.168
	71.4°	0.583	2	2	2	0.168
	153.2°	0.973	4	4	0	0.170
value of a given by this is $a = 4.17 \times 10^{-8}$ cm.						

The authors of this method have developed the theory a great deal further, but we must content ourselves with having given an outline of it.

Hull in the United States, Bragg in England, Mauguin in France, Debye in Switzerland and many others have, during the last few years (from 1921 onwards), determined the structure of hundreds of kinds of crystals, not only elements (nickel, copper, silver, iron) and minerals (oxides, sulphides or carbonates) but also organic compounds.

The study of crystals has been developed enormously during the last decade side by side with the analysis of X-rays, which has now become an easy matter owing to the possibility of determining the wave-lengths with a high degree of precision; not only has the constant d been measured exactly for rock-salt (2.814×10^{-8} cm.) but also a special study has been made of calcite, etc. The face 100 for this latter body gives $d = 3.029 \times 10^{-8}$ cm.

The use of calcite is preferable to that of rock-salt, different specimens of which show variations in density. It is, however, clear that it is easy to change from the constant d for rock-salt to that for calcite by using monochromatic X-radiation of any wave-length λ , since

$$\lambda = 2d_1 \sin \theta_1 \quad \text{for rock-salt.}$$

$$\lambda = 2d_2 \sin \theta_2 \quad \text{for calcite.}$$

* Actually one series is more extensive, but only a few angles are quoted in the table for the sake of conciseness.

The two angles, θ_1 and θ_2 , at which this radiation is reflected, are measured and then d_2 is found if d_1 is known already, or *vice versa*.

Another line of investigation which has to do with crystals is the study of the forces which hold in position the ionic lattice structure.

It has been found (Born) that, although ions which are oppositely charged attract each other when their distance apart exceeds their diameter, at shorter distances than this they repel each other. The importance of this law governing the mutual forces between the ions will be readily understood since with it are bound up the physical properties of a crystal. For an account of the work of Born, Landé, Joffé, Herzfeld, etc., on this subject we may refer the reader to Joffé's book, "Physics of Crystals" (1930).

Piezo-electric Properties of Quartz—Supersonics

It is clear that in this chapter dealing with crystals, and in any treatise on Physics, there should be some reference to the *physics of crystals*, i.e., to the work which has been done in investigating their electrical, magnetic, elastic, thermal and other properties. We shall not explore this very extensive field but shall limit ourselves to a brief reference to one branch of the subject, viz., piezo-electricity.

Piezo-electricity was discovered by Haüy in 1817, and was brought to notice again by Curie, in 1880; as its name implies, it deals with the production of electric charges as the result of pressure or, more exactly, the electrical polarization of the ions which make up the crystal structure. Every ion, since it possesses an electric moment, may be considered as an electric *dipole*. Under normal conditions, the dipoles are oriented at random in all directions so that the resultant electric moment is sensibly zero for any volume of the crystal, which is not too small.

Compression produces a deformation and consequently a state of elastic tension within the crystal. The individual dipoles orient themselves, change their electric moment and give rise to a resultant electric moment which is no longer zero. The phenomenon takes the form of the appearance of electrical charges

on the surfaces of the crystal and is analogous to the formation of fictitious magnetic masses at the surface of a magnetised body.

It is not every quartz crystal that possesses this property. Piezo-electric quartz is found only in certain mines and has to be specially worked. For practical purposes rectangular plates are used and these are cut so that one pair of opposite faces are normal to a crystallographic axis called the "electric axis" (and parallel to the optic axis). Two plates are placed against these faces so that the whole system acts as a condenser. If a compressive force be applied to the plates, electric charges of opposite signs appear (due to the polarisation of the dielectric), and these charge up the condenser. The charge and the difference of potential V between the plates are connected with the applied pressure p by the equation

$$p = aV^2 \quad . \quad . \quad . \quad . \quad . \quad . \quad (1)$$

where a is a constant.

In the case of certain practical applications, the inverse effect is important; if a crystal of piezo-electric quartz be placed in an electric field (suitably directed), then elastic strains are set up inside the crystal due to the rotation of the electric doublets, and as a result the crystal undergoes a deformation similar to that produced by mechanical compression.

Among the many applications of piezo-electric quartz we shall describe the measurement of pressures and the use of quartz oscillators. The former application is one in which the direct effect is used, while the inverse effect is the basis of the oscillator.

There are many technical problems in which it is necessary to measure pressures that are varying rapidly, as for instance in the study of the cycle of operations in an internal combustion engine or of the pressures set up during the firing of the charge in a gun. The best method consists in placing a condenser, built up on a piece of piezo-electric quartz, somewhere close to the point at which it is desired to make the measurement.

The difference of potential V produced by the pressure p can be measured by some electrical method, the best being an *oscillograph*. From equation (1) the value of p may be deduced.

Quartz oscillators consist of a number of quartz crystals cut

as described above and having attached to their faces two metal plates of suitable thickness which form the plates of a condenser.

This condenser forms part of an oscillating electric circuit with thermionic valves, and it is, in fact, inserted in the grid circuit of the first valve ; the circuit is then said to be “ *controlled* ” by the crystal.

The quartz crystals and plates can execute longitudinal *elastic* oscillations. They behave as if there were *resonance*—*i.e.*, equality of frequency—between these elastic oscillations and the electric oscillations in the circuit. Once this resonance has been established it is sufficient to disturb the elastic equilibrium slightly (*e.g.*, by tapping the plates) in order to set up persistent elastic oscillations (of constant amplitude) in the plates, and corresponding electric oscillations in the circuit. The period of these oscillations depends primarily on the dimensions of the crystals and the plates. In view of the constancy of the period of oscillation, such a system can be used to produce a standard of frequency, and these standards may be for acoustic or supersonic frequencies.

An important application of quartz occurs nowadays in the supersonic range, *i.e.*, with frequencies higher than 30,000 per sec. A piezo-electric quartz condenser acting as an oscillator provides a source of homogeneous supersonic waves which can be greatly intensified by arranging for the necessary power to be supplied electrically to the plates ; it is, moreover, possible to limit the emission of the waves to a fairly narrow cone (*e.g.*, one of 15° aperture).

In other words, it is possible to *direct* the supersonic waves. For this purpose it is sufficient to use a wave-length which is of the same order of magnitude as the transverse dimensions of the plates of the condenser. Under these conditions, diffraction effects cause the waves to interfere so as to destroy the sound in all directions which lie outside a cone having its apex at the condenser and its axis normal to the plates.

For a plate of quartz acting as resonator the thickness is equal to the half wave-length (or its harmonics) ; actually the thickness of the quartz is less, since the metal plates which constitute

the condenser and enclose the quartz also take part in the vibration.

An empirical formula has been deduced experimentally for finding the frequency f in terms of the thickness s (in millimetres) :

$$f = (2870/s) \text{ kilocycles per sec.}$$

Thus, in order to obtain the frequency of one million necessary for transmission on 300 metres wave-length the thickness needed is

$$\frac{2870}{1000} = 2.87 \text{ mm.}$$

This empirical formula can be explained immediately. Since $f = (\text{velocity})/2s$, and since the theory of elasticity shows that the velocity of propagation is $\sqrt{(\text{modulus of elasticity})/(\text{density})}$, it follows that for quartz

$$v = \sqrt{\frac{7.9 \times 10^{11}}{2.65}} = 545,000 \text{ cm./sec.}$$

whence $s = 545,000/2f$.

Thus, finally, $f = 545/2s = 273/s$, where s is measured in centimetres. It will be seen that this approximates very closely to the empirical formula. The crystal is not isotropic, and the effect of this on the calculation just made will readily be understood.

Piezo-electric quartz is used in the *under-water depth measurer* used in studying ocean depths, and in detecting objects below water at distances of 5 or 10 km. such, for example, as submarines.*

These objects have the property of reflecting the sound waves so that a certain fraction of the emitted energy is returned to the sending station.

This type of apparatus consists of a quartz oscillator emitting supersonic waves, a receiver for detecting the reflected waves, and a chronographic device (often an oscillograph) by means of which it is possible to measure the time taken by a signal to transverse twice the distance to be determined. In practice the same quartz condenser acts as an excellent receiver, since the reflected waves, being in resonance with the possible elastic vibrations of the plates, cause such oscillations, compress the quartz and thereby produce differences of electrical potential in the condenser. These are then registered by the oscillograph.

Such apparatus is now of great service to the navies of all nations.

* Since the energy is proportional to the area, and it is not possible to use large plates in this submarine acoustic work, a number of plates of equal thickness are arranged in a plane after the manner of a mosaic.

It will be understood that the vibrations of the plates create enormous pressures in the water on account of the small compressibility of liquids ; the displacement of the liquid is very slight, but the acceleration is exceedingly great ; the *radiation pressure* is therefore large. Wood has performed some very interesting experiments on the effect of supersonic waves on fish and on frogs,* and has obtained frequencies up to 500,000.

Langevin, too, has developed some noteworthy applications of piezo-electric quartz.

BIBLIOGRAPHY

- P. P. EWALD. " Kristalle und Roentgenstrahlen " (1923).
 W. H. and W. L. BRAGG. " X-rays and Crystal Structure " (1924).
 R. W. G. WYCKOFF. " The Structure of Crystals " (1924).
 P. DEBYE and P. SCHERRER. " Interferenzen an regellos Teilchen in Roentgenlicht," *Phys. Zeit.*, 17, p. 277, 1916 ; 18, p. 291, 1928.
 M. BORN. " Atomtheorie des festen Zustandes " (1923).
 M. C. NEUBURGER. " Kristalbau und Roentgenstrahlung " (1924).
 W. VOIGT. " Lehrbuch der Kristallphysik " (1928).
 A. F. JOFFÉ. " Physics of Crystals " (1929).

* Reports to the Como Congress, 1927.

CHAPTER VIII

RADIOACTIVITY

Henri Becquerel—Pierre and Marie Curie

IN 1895, Röntgen discovered the X-rays ; on the day when the first Röntgen radiographs were presented to the " Académie des Sciences " by Henri Poincaré (viz., January 20th, 1896), Becquerel asked his illustrious friend from what part of the X-ray tube these rays were emitted ; the reply was that the radiation was emitted from that part of the glass wall on which the cathode rays impinged. H. Becquerel immediately set himself to find out whether any bodies besides glass, when rendered fluorescent * or phosphorescent not by cathode rays but by exposure to light, would emit radiation analogous to X-rays. His choice fell on the salts of uranium. Inside a small enclosure consisting of a black cardboard box covered with aluminium sheet 2 mm. in thickness, he placed a photographic plate with its sensitive side uppermost, while above the aluminium he placed several patches of a double sulphate of uranium and potassium.

Thinking that exposure to light was necessary in order to produce phosphorescence, he exposed the whole apparatus to sunlight ; when the plate was developed it showed dark patches similar in shape to the patches of phosphorescent material.

The great discovery was not yet made ; the sunlight might be regarded as having caused the emission of the new rays. The sky being overcast for several days, Becquerel, while waiting for the sun to reappear, put away his box with the uranium sulphate in a drawer ; three days later the sun reappeared, and Becquerel was about to expose the plate in its box when it occurred to

* A body is called phosphorescent when the light emitted persists after the removal of the cause of the phenomenon ; it is fluorescent when the emission ceases simultaneously with the cause.

him that an effect might have been produced in the darkness of the drawer. He therefore hastened to develop the plate ; it was found to be affected, and thus exposure to sunlight was shown to be unnecessary ; radioactivity was discovered. He repeated the experiment, using other uranium salts and different times of exposure ; he found that the new radiation was emitted in every case so that it was evidently a new property belonging to the uranium atom, *i.e.*, independent of the state of combination of this atom ; the emission of the radiation was spontaneous, as it took place when any possible external cause was excluded ; it seemed to violate the principle of the conservation of energy, for at that time there was no reason for supposing that matter might itself be a store-house of energy ; the radiation was, actually, a form of energy.

From the beginning of his researches, Becquerel observed one of the most important effects of the new rays ; they caused air—or any gas—to discharge electrified bodies, a property which had already been noticed in the case of Lenard rays and X-rays. The first are, as is well known, cathode rays which are allowed to emerge from the tube through a thin window of aluminium which replaces the glass in a certain portion of the wall. This ionisation effect lends itself to precise measurement, and to-day, in one form or another, it is the basis of the method used for measuring the intensity of any given radiation.

Radioactive substances, then, act similarly to Röntgen rays in that they cause air and gases in general to lose their insulating properties.

The way in which gases become ionised is well known ; under the influence of the rays emitted by radioactive substances, or the Lenard rays, X-rays, etc., a certain number of molecules of the gas are split into two parts, an electron and a positive particle which carries a charge equal in magnitude but opposite in sign to that of the electron. The gas, then, contains charged centres called ions ; they are capable of moving about within the gas.

Ions carrying opposite charges combine with each other, but when the ionising agent acts continuously, new ions are constantly being formed.

If the ionising agent is constant, a state of equilibrium is established between the formation of ions and their recombination to form neutral molecules, so that the number of ions per unit volume remains constant.

We know already that when an ionised gas passes between two electrified plates oppositely charged there is a movement of the ions forming a kind of convection current, for each plate attracts to itself the ions which are oppositely charged. If the ionising agent remains constant while the intensity of the electric field between the plates is varied, it is found experimentally that the current tends towards a limiting value, the *saturation current*.

The reason for this is easily seen. At first, if the intensity of the field is small, the ions acquire low velocities and do not all reach the plates because the greater number of them recombine; the more intense the field the less will be the recombination, and so the current will rise. A time will come when the intensity of the field has risen to such an extent that all the ions formed in the gas are collected at the plates; the current then becomes constant. If the field is still further increased, a new effect is produced; the ions acquire velocities which are so great that they can themselves, by collision with molecules, produce a further ionisation, fresh ions are formed, and these in their turn split up other molecules, the current increases rapidly, and finally a disruptive discharge takes place and an arc is formed.

Every electrified body placed in an ionised gas becomes discharged, since it attracts to itself those ions which are charged oppositely; this explains the loss of charge by electrified bodies placed near a uranium salt, the radiation from which ionises the air. H. Becquerel found that by measuring the speed of discharge of an electrified body—or still better, the saturation current—it was possible to compare the *activities* of the various radioactive substances.

The gold-leaf electroscope is a very familiar piece of apparatus; if the knob is touched with a charged body, the rod becomes charged and the leaves separate; the electroscope retains its charge over a long period; nevertheless, since the air is always

slightly ionised and the paraffin insulators are not perfect non-conductors, there is a very slow leak ; before the apparatus is used, this natural leak is measured so that it can be allowed for. By means of a sensitive electroscope, H. Becquerel proved that the activity of uranium is a property of the atom and is independent of the state of chemical combination of the uranium ; actually he placed various compounds of uranium having equal radiating surfaces at equal distances from the electroscope and found that the apparatus was discharged more quickly as the uranium content was increased, and that the activity was proportional to the amount of uranium present. He proved, among other things, that very large variations of temperature, from -190 to $+80^{\circ}\text{C}$., did not affect the radiation. It was immediately seen from this that radioactivity was a property of the atom ; whether the atom is free or in combination, whether it is in the liquid, the gaseous or the solid state, the characteristic rays of the element are emitted with an intensity which is proportional to the quantity of the element present, and they are in no way affected either by the state of combination or by the physical condition of the atoms ; a given quantity of radium emits the same rays with the same intensity when the radium is in the pure metallic state, as it does when the element is in combination as sulphate or chloride ; a given quantity of emanation (radon) emits the same radiation, both in kind and in intensity, whether it be in the gaseous state—its normal condition—or whether it be solidified by means of liquid air.

The radioactivity of substances is equally unaffected by other changes in the prevailing conditions.

In modern laboratories it is possible to subject a sample of any material to the most powerful influence, viz., extremely high temperatures, cold sufficient to solidify any substance, very strong electric and magnetic fields, or intense illumination. All these have been tried on a vast scale and over the whole range of variation known to man, but in every case the radioactivity has shown no perceptible variation and has proved to be unaffected by any external influence.

Following on Becquerel's discovery, Pierre and Marie Curie,

having confirmed the fact that the effect of any given quantity of a compound of uranium was strictly proportional to the amount of the element which it contained, noticed that the effect due to certain minerals and certain ores containing uranium was much greater than that proper to the uranium content of the minerals. Thinking that there might be some constituent of these ores which had the same property as uranium, but to a greater extent, they set themselves the task of isolating this substance; it was an arduous piece of work.

In 1898, after three years of patient labour, polonium was first isolated and then radium.

We shall pass over the details, which are described elsewhere.

In 1899 Debierne discovered—also in pitchblende, the mineral which the Curies had investigated—another radioactive element, *actinium*; to-day the number of radioactive elements has risen to about 40.

It is not possible for us to recount the story—though it would be interesting to do so—of these discoveries which were made in the course of a few years, and which had their birth in Paris, in small laboratories where the meagre facilities available were vastly augmented by the inspirations of genius and by the assiduity of the research workers. An atmosphere of romance relieved the simplicity, for surrounding Pierre Curie were Langevin, Debierne and Perrin.

In their laboratories, bare of costly apparatus, other men like Berthelot, Pasteur and Lippmann had also spent years of arduous labour, which had yielded, for the benefit of humanity, a fruitful harvest such as had rendered their names immortal.

Pierre Curie met the tragic end which is known to all; he was run over by an automobile and his head crushed; but this is not the only tragic episode in the history of radioactivity. This epic, which recounts the story of a succession of brilliant discoveries, such as have had a fundamental effect on physical science, on chemistry, and indeed on the trend of all scientific thought, is not devoid of dramatic interest, for several brave men who devoted themselves to a study of the effects of radium on the human body have died only after appalling mutilation; the new element with

the magic name had, from the very day of its first appearance, something of the miraculous about it ; its rays passed through matter, its reserve of energy seemed *inexhaustible*, it seemed to have an influence which might be either curative or fatal. It will thus be understood what an impetus was given to research in physics, in chemistry and in medicine when radioactivity, in 1898, opened up a vast field of study to workers throughout the whole world.

The Radiations of Radioactive Bodies

We shall not give a detailed description of the chemical properties of the radioactive bodies, of the historic order of their discovery, of the hypotheses put forward and subsequently abandoned, and, still less, of the various types of apparatus used ; the reader would only be fatigued and there are dozens of specialized treatises which may be consulted by the enthusiast ; we shall restrict ourselves to a brief account of the constructive theories and their effect on modern physics, the progress of which has been so greatly forwarded by the discoveries made in radioactivity.

The rays emitted by the radioactive elements, or by their compounds, are of three kinds : the α -rays, which consist of charged material particles and are of the same character as the canal rays ; the β -rays, which are electrons shot off at very high velocities and are therefore exactly analogous to cathode rays ; these two kinds of radiation are thus *corpuscular*, *i.e.*, they consist of a stream of projected particles and therefore what seems to be a ray is, in reality, the path traversed by a particle.

Finally, the γ -rays, also emitted by radioactive bodies, are electromagnetic vibrations of very high frequency, similar to X-rays.

The various properties of the α -, β - and γ -rays have provided a means for determining their exact nature ; if all the radiation emitted from a sample of radium be acted upon by a magnetic field, the α -rays are deviated in a direction which shows that they consist of positively charged particles ; the β -rays are strongly deviated in the opposite direction ; the γ -rays are unaffected by

the magnetic field. By measuring the deviations produced in a magnetic field and in an electric field it is possible, as in the case of cathode rays and the positive rays, to determine the velocity of the particles composing the α - and β -rays, as well as the ratio (e/m) of the charge carried by these particles to their mass. These measurements have shown that the β -rays are composed of electrons having very high velocities, 40 to 80 per cent. of the velocity of light; for a certain radioactive element (radium C) the velocity attains a value equal to 97 per cent. of that of light.

The α -rays are the most important; the velocity with which they leave the atom emitting them is of the order of 15,000 km. per second, according to the nature of the radioactive substance; on the other hand the ratio e/m is always half that found for the hydrogen ion.

This remarkable result could be explained by supposing that each α -particle carried a single charge, e , and that its mass was double that of an atom of hydrogen; actually, however, this particle has a mass 4 and a double charge, *i.e.*, it is an atom of helium with two elementary charges: Ramsay proved this definitely. He enclosed a small quantity of a radioactive substance (radium emanation) in a glass tube, the walls of which were sufficiently thin to allow the α -particles to pass through them. This tube was sealed and was enclosed in another larger tube, which was evacuated, and which contained electrodes to enable a spark to be passed through the tube so that the contents could be examined spectroscopically. The spark discharge through whatever gas was produced in the larger tube would indicate the nature of this gas, and no more sensitive means of analysis could be devised. After two days the spectrum of helium appeared, and as time went on it increased in intensity.

This was a great moment for Ramsay, and an important turning point in chemistry and in natural philosophy as well; it was the first time that one element had been formed out of another.

These experiments proved to demonstration that the α -particles were helium atoms.

The α -rays, then, are composed of particles having a mass of

6.6×10^{-25} gm., and carrying a charge $2e = 9.55 \times 10^{-10}$ electrostatic units.

When α -rays strike any phosphorescent and fluorescent body they cause it to emit light; barium platinocyanide and zinc sulphide give a greenish glow.

The effect produced by these rays on a photographic plate—to which their discovery was due—is the result of their power of causing chemical action.

The α -particles emitted by different radioactive substances differ only as regards their initial velocity, and the degree of variation is relatively slight; the slowest α -particle is, in fact, emitted with a velocity of 1.42×10^9 cm. per second (uranium I) while the fastest is emitted from thorium C' with a velocity of 2.069×10^9 cm. per second.

The γ -rays are—as has been said already—of the same nature as X-rays, *i.e.*, they are electromagnetic vibrations similar to light; but whilst the X-rays have wave-lengths which are of the order of a thousandth part of the wave-lengths in the ultra-violet, the γ -rays, in their turn, have wave-lengths which are much shorter than those of the Röntgen rays.

The γ -rays are only emitted by substances which also give off β -rays and the most penetrating γ -rays are emitted in company with the fastest β -rays. In the same way as the Röntgen rays are produced by the sudden stoppage of electrons by an obstacle, so the γ -rays seem to result from the disturbance caused by the sudden expulsion of a β -electron. Briefly, the γ -rays are very penetrating X-rays and, like these latter, they are reflected from crystals; they have been studied by different physicists,* using a method which we shall meet with in Vol. II, Chap. V (the method of corpuscular radiation). The wave-lengths of γ -rays cover the range between 1 Ångström and 0.005 Ångström units.

The α -, β - and γ -rays may be distinguished from each other by their *penetrating power*. The α -rays cannot penetrate more than

* Ellis, M. de Broglie, L. Meitner, Rutherford, Thibaud.

a few centimetres of air and do not pass through sheets of metal more than 0.1 mm. thick. The more penetrating β -rays can pass through several millimetres of aluminium. The γ -rays are the most penetrating; they travel considerable distances in air and can pass through iron or lead plates several centimetres in thickness; they are only slightly reduced in intensity by passage through the human body.

The origin of the β -particles is not as obvious as that of the α -particles because electrons, with the same charge and mass, are present just as much within the nucleus of the atom as outside it. However considerable progress has been made during the last few years in our knowledge of this subject. The β -particles are not all emitted with the same velocity from any one kind of atom, but their velocities cover a certain range; for certain radioactive elements there are, in addition to this continuous spectrum of velocities, certain characteristic velocities. Consequently, in a method to be described later, if the β -rays, after emission, are variously deviated by means of a magnetic field and are allowed to fall on a photographic plate, the record consists of characteristic lines superposed on a continuous background.

Very delicate experiments have proved that *only one* β -particle is given off from each single atom when it breaks down (a β -transformation is referred to here).*

The most important property of these different rays is their power of ionizing gases. Gases become conductors when in the neighbourhood of a radioactive body and this conductivity, measured by means of an electroscope, provides a means for determining the intensity of the radiation, and so for measuring the radioactive content. The active material is placed between two metal plates, one of which is connected to the case of an electroscope, the other to the leaves. Under these conditions the charge of the electroscope is dissipated at a rate dependent on the activity of the material placed between the plates. By measuring the rate of discharge, therefore, it is possible to

* R. W. Gurney, "The Number of Particles of the β -ray Spectra of Radium B and C," *Proc. Roy. Soc., A*, 109, p. 540, 1925. K. G. Emeléus, "The Number of β -particles from Radium E," *Proc. Camb. Phil. Soc.*, 22, p. 400, 1924.

determine the radioactive content of any material. The method is extremely sensitive ; it is possible in this way to detect the presence of one 50 millionth of a milligram of radium.

The Spinthariscopes. The spinthariscopes, invented by Crookes in order to make the α -particles visible, is the most sensitive instrument conceivable, and is not the less remarkable on this account.

If anyone had said to the famous physicists who first calculated the weight and dimensions of the atom that one day a single atom would be observed, just one from among those which they had found to be present in thousands of millions in a cubic millimetre, they would have smiled incredulously.

This is what the humble instrument known as the spinthariscopes has made possible ; a needle, the point of which has been plunged into a phial which has contained radium, is placed in a small brass tube having at the bottom a layer of zinc sulphide as detector ; at the upper end of the tube is a lens which magnifies the effect to be observed.

The eye sees the scintillations of the zinc sulphide layer ; these appear like shooting stars which die out immediately after their appearance, and each signalises the arrival of a projected particle, in the same way—Perrin remarks—as a rocket is seen although the apparatus which fires it may not be visible.

The scintillations are so numerous all over the field of view that it is impossible to count them ; it seems incredible that such an incessant bombardment of the screen can be produced by such an infinitesimal quantity of radium. The reason is, however, that although the mass of the α -particle is extremely small, its velocity is so great that the kinetic energy which is dissipated in the material of the screen ceases to be very small.

The α - Particles and Methods of Counting them— Determination of their Charge

It has been said already that the α -rays are the most readily absorbed part of the radiation ; they cannot pass through a sheet of paper ; the most penetrating (*i.e.*, those having the highest velocities) cease to produce any effect on a photographic plate

or any ionizing action after they have passed through 8.6 cm. of air at atmospheric pressure.

Rutherford's experiments (1903 and onwards) to determine e/m were carried out in this way.* In order to obtain a homogeneous beam it was necessary to use a very thin film of radioactive material, otherwise the particles emitted from the internal layers would be slowed down. Rutherford made use of a very fine layer of salt (a radium salt) obtained by immersing a thread in a dilute solution; the thread was placed in a shallow trough, A, shown in Fig. 95; B was a slit parallel to A, while at MM was placed a photographic plate; the whole system was contained within an evacuated vessel.

The apparatus was placed between the two poles of an electro-magnet, producing a field parallel to the thread; first a line was obtained at C_1 and then, by reversing the field, a second line at C_2 was produced. The radius of the circular path followed by the particles could easily be calculated since the path was defined by the three points, A B C_1 (and A B C_2). A similar experiment was carried out in an electric field, and from the two equations for the respective deviations, the specific charge, e/m , and the velocity v could be obtained, as was shown in the case of the cathode rays.

Rutherford obtained :

$$e/m = 5000 \text{ c.m.u. per gramme}$$

$$\text{velocity } v = 20,000 \text{ km. per sec.}$$

The production of helium, proved by a direct method, has shown without any possible doubt that, as has been said already, the mass m of the α -particle is 4 and, therefore, that every particle is an atom of helium carrying two elementary charges. We shall

* E. Rutherford, *Phil. Mag.*, 5, p. 177, 1903.

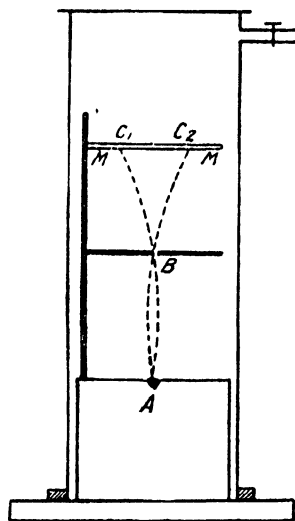

FIG. 95.

explain briefly how it has also been possible to *make a direct measurement of the charge* of an α -particle.

It has been stated already that Sir Wm. Crookes discovered that a minute grain of a radioactive salt, placed close to a screen of zinc sulphide, produced a scintillation effect on this screen and that this scintillation when viewed under the microscope appeared like a constantly changing starry sky. As Crookes imagined, each fleeting star indicated the point of arrival of a particle; by collecting the α -radiation in a metal cylinder connected with an electrometer, Rutherford measured the positive charge q emitted per second in the form of α -particles from a measured mass of a polonium preparation; he then determined (as we shall see shortly), by measuring the conductivity of the air, the charges $+Q$ and $-Q$, which are set free, owing to ionisation, by the rays emitted in one second when these are totally absorbed by the air, using the same quantity of the same polonium preparation as before.

He obtained $Q = 94,000q$, a result which is independent of the quantity of polonium, since both Q and q are proportional to this quantity.

Then Regener, in 1908, thought of using Crookes' spinthariscopes to count the α -particles and to apply Rutherford's result to the determination of the charge of a single particle. Regener counted one by one the scintillations produced in a small diamond by the radiation emitted from a preparation of polonium within a very small solid angle, and he deduced the total number, n , of particles emitted per second; he also measured the quantity of electricity *liberated* by ionisation in the air, due to the radiation from the same quantity of polonium preparation.

The value of $Q/94,000n$ is, then, the value of the charge of a single particle; this was found to be 3.19×10^{-20} c.m. units, a value twice that found by Millikan for the electron. Further, since $e/m = 5,000$ it followed that $m = 6.3 \times 10^{-24}$ gm., a value exactly equal to the mass of the atom of helium, four times that of the atom of hydrogen.

We give in Fig. 96 a diagram of Regener's apparatus;* the

* E. Regener, *Berlin Berichte*, p. 948, 1909.

detector used for counting may be a plate of zinc sulphide or a diamond 0.1 mm. thick. Knowing the distance of the polonium preparation from the detector and the area of the latter it is easy to deduce from the observed scintillations the total number of particles which are emitted by the sample.

Another method, due to Rutherford, led to the same result, the number of particles being measured in this case by means of an electrometer. The basis of this experiment is that the ionisation

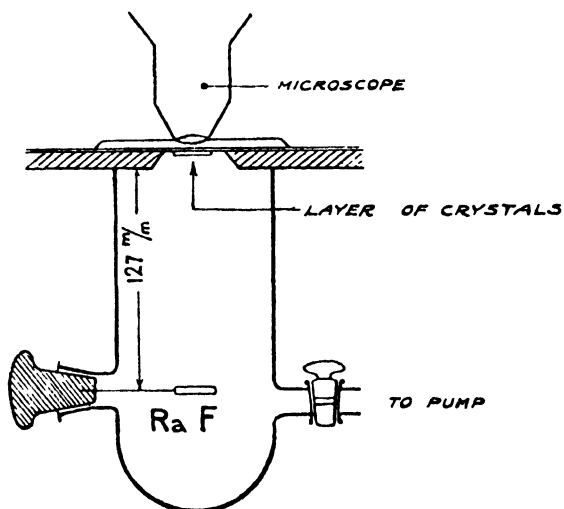

FIG. 96.

can be multiplied a hundredfold by causing it to take place in an intense electric field.

A tube of 25 cm. diameter, containing a small sphere, the surface of which is covered with a thin layer of active material, is connected with a brass cylinder through a small aperture ($1\frac{1}{2}$ mm. diameter) in a mica diaphragm (see Fig. 97). This brass cylinder is the ionisation chamber and placed axially within it is an insulated wire; this wire is connected with one pair of quadrants of an electrometer, while the walls of the cylinder are connected to the negative pole of a battery of accumulators, the other pole of which is earthed. The active material projects its α -particles through the diaphragm and into the ionisation chamber,

where the pressure is from 2 to 5 cm. of mercury ; the distance of the active material from the diaphragm is so adjusted in relation to the size of the hole that the brass cylinder only receives three or four α -particles per minute.

Every time a particle enters the ionisation chamber the effect on the electrometer is recorded photographically ; if, by chance, several particles enter simultaneously, the amount of the deflection recorded shows what has happened.

With this arrangement, from a knowledge of the position of the sphere and its superficial area, and of the size of the aperture, it is obviously possible to calculate the total number of α -particles

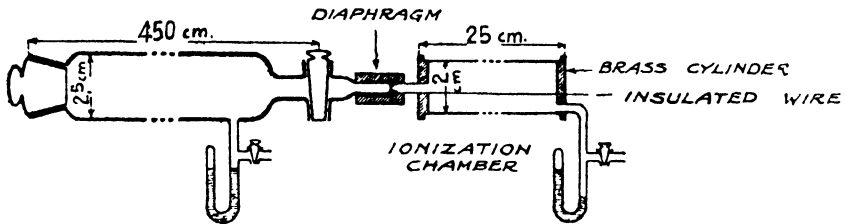

FIG. 97.- Counting the α -particles. Rutherford and Geiger, 1908.

emitted per second from 1 gm. of radium ; the result found is as follows :—

One gramme of radium emits 136×10^9 α -particles per second.

If, then, the total charge, q , which is collected per second in a Faraday ice-pail, be measured (the β -rays being deviated by means of a magnetic field), and if q be divided by 136×10^9 the result is the value of the elementary charge ; Rutherford and Geiger* using this method, found that $e = 3.1 \times 10^{-20}$ e.m.u., a value which, as has been said already, is double the charge of an electron.

Radium Emanation

Among the facts which have explained the true nature of radioactivity, it is necessary to mention the discovery of radium emanation.

* E. Rutherford and H. Geiger, *Proc. Roy. Soc.*, 81, p. 162, 1908.

If radium bromide be dissolved in water and the solution be then evaporated to dryness, it will be found that this process has deprived the radium of the greater part of its activity; the β - and γ -rays are entirely absent and the α -rays are reduced to one-quarter of their original intensity. If, however, the radium be left untouched, it gradually regains, day by day, the activity which it has lost and at the end of a month the radioactivity has once more the same value as at first. Dissolving the salt in water has caused the removal of a substance, actually a gas, which diffuses into the surrounding air and makes it radioactive; this gas is *radium emanation*—called niton or radon to distinguish it from the emanations given by thorium and actinium; this gas is intensely radioactive and has a characteristic spectrum.

It is well known that this effect is brought about, not because the substance which has lost the emanation re-absorbs it from the air (in the same way as a salt which has lost water regains it by absorbing water-vapour from the air), but because a fresh supply of emanation is produced by the disintegration of further radium; in fact, it is realised that radioactive transformations take place in one direction only; they cannot be reversed any more than can the changes which the human frame undergoes; individuals change and die but cannot return to what they were.

The emanation which escaped on solution had been imprisoned in the salt, that which escapes in a repetition of the experiment is a freshly formed supply, and so on.

Rutherford and Soddy first succeeded (1902) in condensing the emanation at -150° ; its chemical nature is completely known and is similar to that of the inert gases of the atmosphere; thus radon is in the same column as helium in the periodic table; the atomic weight (222) is determined from the velocity with which radon passes through a very small aperture.

Of the 135 calories, approximately, generated by a gram of radium per hour, 100 are due to the emanation.

Thus an element similar to barium, a solid, and a body with marked chemical affinities, gives birth to another element which differs from its progenitor as much as two bodies can differ from each other; the first is a metal, while the second is a gas. The

significance of this phenomenon is that the transmutation of matter occurs spontaneously in nature.

This is not all, however; the transformation of radium into emanation is actually only the first of a series of successive transformations of the same kind; the gaseous emanation, in fact, changes, in its turn, into a third non-gaseous body with a short life; this forms a fourth body called radium B, and so on for nine successive transformations.

We shall deal with this more fully a little later.

The Number of the Radioactive Elements and their Threefold Grouping

Before the discovery of radioactivity, uranium and thorium were already known; the first radioactive elements to be discovered on account of their radioactivity were, as has been said already, polonium, then radium and then actinium. Later on others were gradually separated, to the number of forty. We shall not describe either the properties of radium or those of the other elements; in the case of radium we shall only note that it is allied to barium in all its chemical properties; the atomic weight is 226, and in the periodic classification it takes its place in the column with the alkaline earth metals.

The observations on radioactive phenomena taken as a whole—and notably the discovery of the emanation—led Rutherford and Soddy to a theory of radioactivity which explains all the known facts about it and discloses the genealogical relationship between the elements.

This theory states that a radioactive element is undergoing continuous transformation and is giving birth to other elements; the transformation does not take place simultaneously in all the atoms, but in a given time a certain fraction, and always the same fraction, of the atoms *not already* transformed are involved in the change; some atoms explode, the rest remain unaltered.

An atom which explodes is a system which, for some reason or other, is no longer in a stable arrangement; after the explosion, a rearrangement of the atomic structure into a fresh form takes place, and this form, which may be either permanent or temporary,

constitutes an atom which is chemically different from that which has split up. Thus, in exploding, the radioactive element shoots off another of mass equal to or less than its own, and in addition, it emits α -, β - and γ -rays, the energy of which is converted into heat.

The emission of α -rays consists in the violent expulsion from the radioactive atom of an atom of helium (atomic weight 4) carrying two charges of positive electricity. The original atom is necessarily charged and the new atom has an atomic weight which is 4 units less; for instance, the atom of radium with atomic weight 226, by expelling an α -particle, gives an atom of emanation with atomic weight 222, and the equation representing the transformation is :

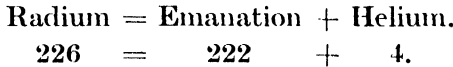

The emanation emits an α -particle in its turn, and gives an atom of radium A (RaA = 218) and so on until a stable element is reached.

This is the process by which a radioactive family is established, the last member being a stable element; the detailed study of these genetic relationships has enabled all the known radioactive elements to be put into three groups, the uranium group, the thorium group and the actinium group; the first of these, which is the most important, includes radium and finishes with lead as the stable end element resulting from a series of successive disintegrations which reduce the atomic weight 238 (uranium) to 206 (lead). (See Fig. 98.)

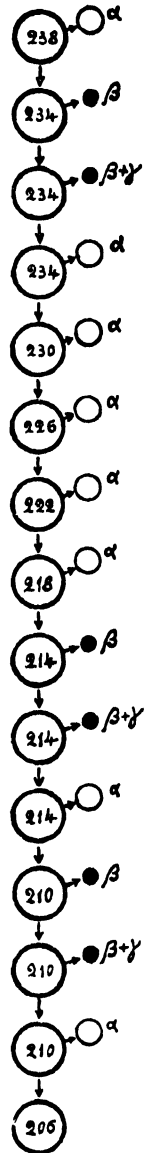

FIG. 98.—
The uranium family.

Radioactive Evolution—The Disintegration Law

The loss of an electron does not cause any appreciable change of atomic weight; it will be remembered, in fact, that the mass of the electron is only 1/1840 times that of the

atom of hydrogen. Nevertheless, the residual atom is quite different from the original atom. Thus radium B ($\text{RaB} = 214$) gives, on the expulsion of a β -particle, an atom with the same mass but different properties, radium C ($\text{RaC} = 214$) which, in its turn, emits another β -particle and gives a further very different element with the same mass, viz., radium C' ($\text{RaC}' = 214$).

An atomic explosion—signalled by the expulsion of an α - and a β -particle—does not take place simultaneously throughout the whole of the radioactive material; out of a million atoms of radium (in round numbers), only one is transformed each day; the others remain unaltered and disintegrate one by one on successive days. There is, then, no question of a gradual change of properties; as the substance is being transformed, there always remains some unaltered material, but the amount of this becomes gradually less and less.

The fundamental law which governs such transformations is that the percentage of atoms which are transformed in unit time is a constant.

This is called the transformation constant and is characteristic of the element; it will readily be understood that simple arithmetic is insufficient to solve the problem of finding out how many atoms in, say, a million of those in existence at any given instant will remain unaltered after the lapse of a certain time, the transformation constant being known, of course. The insufficiency of arithmetic will be seen from the fact that, although it is perfectly true that a constant fraction of the atoms present are transformed in each second, yet since the number of these atoms is continually decreasing, the number of atoms undergoing transformation in unit time is also constantly on the decrease; in short, recourse must be had to the differential calculus.

If dN be the number of atoms transformed in time dt , the differential equation expressing the relation may be written $dN = -\lambda N dt$, as this shows that the number of atoms transformed is proportional to the quantity of material still unchanged; λ is the transformation constant, *i.e.*, the fraction transformed per unit time. Integrating the equation just written gives the relation

$N_t = N_0 e^{-\lambda t}$ where N_t is the number of atoms unchanged after the lapse of time t .

The same thing may be expressed in terms of weight: N_t then represents the weight of the substance which exists after the lapse of time t ; N_0 is the weight which was present originally.

In the case of radium, for instance, λ is equal to $1/2500$, taking the *year* as the unit of time; this means that in one year, one atom only is transformed out of every 2,500. It is easy to show that the *average* life of an atom, *i.e.*, the *length of time* for which, on the average, any atom in a group selected at a given instant exists from that instant onwards, is the reciprocal of the constant λ (in the case of radium, for instance, the average life is 2,500 years). In fact, if θ is this average life for n_0 atoms, the sum of the lives of all these atoms is $n_0\theta$ and this is given by the integral $\int_0^\infty n_0 e^{-\lambda t} dt$, which is the sum of all the various times of existence of all the atoms before they are transformed.

Equating these two expressions we have

$$\theta n_0 = \int_0^\infty n_0 e^{-\lambda t} dt$$

so that, immediately, $\theta = 1/\lambda$, as stated above.

Uranium Series

Atomic Number	Element	Half-value Period	Average Life.	Radiations Emitted	Atomic Weight
92	Uranium I .	4.4×10^9 years.	6×10^9 years.	α	238
90	Uranium X ₁ .	24.6 days.	35 days.	β	234
91	Uranium X ₂ .	1.15 min.	1.7 min.	β	234
92	Uranium II .	1×10^6 years.	1.5×10^6 years.	α	234
90	Ionium .	80,000 ,,	120,000 ,,	α	230
88	Radium .	1,580 ,,	2,200 ,,	α, β, γ	226
86	Niton (Emanation) .	3.85 days.	5.5 days.	α	222
84	Radium A .	3.05 mins.	4.4 mins.	α	218
82	,, B .	26.8 ,,	38 ,,	β	214
83	,, C .	19.5 ,,	28 ,,	β	214
84	,, C ¹ .	10^{-6} sec.	1.4×10^{-6} sec.	α	214
82	,, D .	16.5 years.	24 years.	β	210
83	,, E .	4.85 days.	7 days.	β	210
84	,, F .	—	—	—	—
	(Polonium) .	136 ,,	200 ,,	α	210
82	Lead .	—	—	—	206

It is to be noted that this average life is not the same as the time, called the "*half-value period*," which elapses before any given mass of radioactive material is half transformed; this will readily be understood, for the same idea occurs in the study of human mortality; if we consider, for instance, a thousand individuals of the same age, say twenty years old, then at forty-five years of age the thousand will be reduced to 500, but this does not mean that *on the average* the thousand persons considered will live twenty-five years, for such an average duration of life is really obtained by taking one-thousandth of the sum of all the lives enjoyed by the thousand individuals. The two ideas are quite different.

It is easy to show that, for radioactive substances, the *half-value period* is $0.693/\lambda$ *; thus for radium the period is about 1,600 years.

The half-value periods of the various radioactive elements cover an extraordinarily wide range, being thousands of millions of years in the case of thorium, 3.85 days for radium emanation, and only a millionth of a second for radium C'.

For radium the transformation constant λ can be readily calculated, since the number of α -particles emitted per second can be counted. Actually the number of Ra atoms contained in a gramme is $N/226 = 60.6 \times 10^{22}/226 = 2.68 \times 10^{21}$; the number of particles emitted from a gramme per second is 3.72×10^{10} , and hence

$$\lambda \text{ for radium} = \frac{3.72 \times 10^{10}}{2.68 \times 10^{21}} = 1.39 \times 10^{-11} \text{ sec.}^{-1}.$$

The average life is found by taking the reciprocal of this value, and is thus found to be 2,200 years.

* Experiment shows that Radioactive Transformations follow the Law of Probability

The fundamental law of radioactive transformation can be expressed by saying that the probability that an atom will be

* From the relation $n = n_0 e^{-\lambda t}$, putting $n = \frac{1}{2}n_0$, we obtain $e^{-\lambda T} = \frac{1}{2}$, whence $T = (\log 2)/\lambda = 0.693/\lambda$.

of the α -particles actually emitted is exactly equal to m , but only that m is the average value, the most probable value of n .

Observations confirm the fact that the number n exhibits fluctuations about its average value m , and that these fluctuations obey statistical laws ; it will be seen, in fact, that this problem is analogous to that met with in the theory of errors already dealt with in Chap. V, for if, on the average, the number of α -particles produced in time Δt is m , and if 1,000 successive determinations be made, there will be found to be differences from m so distributed that in x cases the values lie between m and $1.1 m$; in y cases the values lie between $1.1 m$ and $1.2 m$, and so on ; these numbers $x, y, z \dots$ are functions of m and n alone.

The probability p_n that n atoms will be transformed in the time Δt is given by the expression

$$p_n = \frac{m^n}{n!} e^{-m} \dots \dots \dots (4)$$

This is Poisson's law. In the footnote * on this page will be found a brief demonstration of this law.

* Let us calculate the probability that n transformations will take place in time Δt , and therefore the probability of a difference $(n - m)$ from the average value m , always assuming that the average life is long with respect to Δt , so that the number of atoms transformed per second is not decreasing. The probability appropriate to an interval of length $\Delta t/K$ is m/K . Hence the probability of no transformation taking place in this interval $\Delta t/K$ is $(1 - m/K)$. Considering in this way n of the K intervals, we may say that the probability that there will be one α -particle emitted in each of the n intervals, and none in each of other $(K - n)$ intervals, is (by the theorem of the combination of probabilities) equal to

$$\left(\frac{m}{K}\right)^n \left(1 - \frac{m}{K}\right)^{K - n}$$

It is possible to select the n intervals in $\frac{K!}{n!(K - n)!}$ different ways, and so the total probability that n atoms will be transformed in time Δt is given

$$by p_n = \left(\frac{m}{K}\right)^n \left(1 - \frac{m}{K}\right)^{K - n} \frac{K!}{n!(K - n)!}$$

If now we pass to the limiting case when K becomes infinite, we readily

$$obtain for p_n the expression $p_n = \frac{m^n}{n!} e^{-m}$.$$

Since the *average number* m is very great, the relative fluctuations are small and we obtain, instead of (4), the *Gaussian law of errors* :

$$p_n = \frac{1}{\sqrt{2\pi m}} e^{-(n-m)^2/2m} \cdot \cdot \cdot \cdot (4')$$

where $(n - m)$ now represents the error.

The fluctuations of radioactive phenomena, exhibited in accordance with expressions (4) and (4'), are called Schweidler's fluctuations.

The mean square value for a difference $(n - m)$ is given by the relation

$$\Delta_n = \sqrt{\Sigma(n - m)^2 p_n} = \sqrt{m}.$$

If, then, the interval Δt be doubled so that m is doubled, the average difference increases in the ratio $\sqrt{2}$, while the *relative mean fluctuation* $\frac{\Delta_n}{m} = \frac{1}{\sqrt{m}}$ becomes smaller in the ratio $\frac{1}{\sqrt{2}}$.

There are various methods of measuring these fluctuations in the number of α -particles emitted, and these may be divided into two groups. The first group consists of the so-called integral methods of measurement* in which observations are made of the emission of a large number of α -particles (*e.g.*, 20,000 per minute); in this case, m being large, the expression (4') is found to be verified, and the transformation constant λ may be calculated.

The second group includes those methods which depend on observations of single α -particles and those in which m is small, so that Poisson's expression (4) is verified. We may examine one of these methods more closely; Rutherford and Geiger in 1910 observed the scintillations produced by α -particles which struck a fluorescent screen at a comparatively slow rate, and they recorded the appearance of each scintillation by making a mark on the paper tape of an ordinary chronograph; on this tape marks were also made at regular intervals of time. On the conclusion of a series of observations the time scale was divided

* See article by W. Bothe in *Handbuch der Physik*, Vol. XXII., p. 193.

into equal intervals ($\frac{1}{8}$ second) and the number of scintillations within each interval was noted.

From these data the authors constructed a diagram in which the axis of abscissæ showed the numbers of particles 0, 2, 4, 6, 8, 10, etc., while the ordinates indicated the numbers of intervals in which these various numbers of scintillations were observed to occur; the curve obtained was precisely that given by Poisson's law (4), so that the prediction of the theory was found to be verified experimentally.

The study of the phenomena of radioactivity has led to this important conclusion: the fundamental law expressed in equation (1) or (1') is found to be true in every case; radioactive phenomena occur, then, *as if* the transformations were entirely at random. This does not mean to say that the law of causation does not apply to these phenomena; such an assertion could not be proved. In developing a theory of radioactive phenomena, in fact, we may adopt any hypothesis whatever as to the cause of a radioactive transformation, it is only necessary to suppose that the individual transformations of the atoms are mutually independent, and that in the case of a large number of atoms it is possible to apply the law of large numbers and the statistical laws of probability.

This brings about a considerable simplification in the bases of the theory, and it is in this sense that radioactive transformations may be said to follow probability laws.*

* Let us take a milligram of radium and observe its transformation. Why does one atom suddenly explode and die, why does another atom live for a day, another for a week, others for a month, a year, a century? If atoms are all alike, how is it that there are "healthy" and "unhealthy" ones?

At the present time physics is unable to provide an answer to this question. However, since every fact is connected with some other, from which it results, by the chain of cause and effect, according to our rational line of thought (*determinism*) we are led to think that, in reality, there must be a complex universe in every atom, and, by reason of the intervention of causes not known to us, the death of an atom is occasioned from time to time. Exactly similarly, in considering the incidence of mortality in a city, we cannot know *which individuals* will die on the morrow, but we can know *how many*, because the mathematics of probability has shown us how we may overcome our ignorance, our inability to take account of the extraordinary complication of elementary causes. We are here confronted with a practical problem which is insoluble, though perhaps not for ever.

Determination of Average Life—Radioactive Equilibrium

The methods used for determining the average life of the radioactive elements differ greatly according as the life to be measured is short or long. In the former case a simple direct observation suffices; if, for example, the fall of activity of a given quantity of radium emanation be measured, it will be found that the activity decreases with time according to a geometrical progression law (since $I = I_0 e^{-\lambda t}$), so that the activity is halved in 3.85 days; the average life, which is known to be (1/0.69) as great, is therefore 5.57 days. For a body of which only a millionth part is transformed each year, however, the average life cannot be determined by direct observations, and it is necessary to have recourse to indirect methods. Let us take, for the sake of example, the case of uranium and that of radium; it is possible to determine the activity of radium compared with that of uranium, and, measuring the relative amounts of radiation emitted by equal quantities of the two elements, it is found that the radioactivity of radium is several million times as great as that of uranium; from this it may be deduced that the average life of uranium is several million times as great as that of radium.

In any series of atomic disintegrations, if the average life of a single member of the series be known, the average lives of all the others may readily be found. We shall see directly the reason for this.

We have already said, for instance, that radium disintegrates and gives the emanation called radon (or niton). If the emanation were a non-radioactive gas, it would accumulate and the quantity present in the neighbourhood of a sample of radium would constantly increase. This does not happen, however, since the emanation disintegrates in its turn and gives rise to a solid deposit, radium A, so that after a time the emanation formed by a sample of radium contained in a sealed tube, disintegrates at a rate equal to that at which it is formed. From that time onward, the quantity of emanation present with the radium shows no further increase; equilibrium is stated to have been reached between the radium and its emanation, and at the end of a certain period of time, equilibrium is established for all the

successive products of the disintegration. It can be shown that when *radioactive equilibrium* has been established, the ratios N_2/N_1 , N_3/N_1 , etc., of the numbers of atoms present are equal to the ratios of the average lives, *i.e.*, when equilibrium has been reached, it may be shown that

$$\frac{N_2}{N_1} = \frac{\theta_2}{\theta_1} \quad \frac{N_3}{N_1} = \frac{\theta_3}{\theta_1} \quad \frac{N_4}{N_1} = \frac{\theta_4}{\theta_1}, \text{ etc. } \dots \dots \dots (1)$$

If the volume of emanation in equilibrium with a certain mass of radium be measured, this gives the ratio N_2/N_1 of the numbers of atoms of radium and of emanation which are present when equilibrium has been attained; thus the average life θ_2 of radium, which cannot be measured directly, is obtained from the value of θ_1 , the average life of emanation, which has already been found by a *direct* method.

It will be useful to explain rather more fully the meaning of *radioactive equilibrium*.

It will be clear that there must come a time when equilibrium is reached between the various elements present (if those elements which are formed are not removed as fast as they are formed), for when the atoms of a first element A give, on disintegration, atoms of a second element B, the rate at which B is formed decreases, since the quantity of A which is active is constantly decreasing; hence the amount of B produced cannot exceed a certain limiting quantity, since the greater the number of atoms of B formed, the greater the number which break down; when equilibrium is reached between the primary element A and the derived elements B, C, D, the number $N_A\lambda_A$ of the primary atoms which are disintegrating at a certain instant will be equal to $N_B\lambda_B$ and to $N_C\lambda_C$, etc., because these products represent all the various numbers of atoms which appear in turn, and hence $\lambda_A N_A = \lambda_B N_B = \lambda_C N_C$, etc. Remembering that the various values of λ are the transformation constants and therefore are inversely proportional to the periods, as has been explained already, the set of equations (1) follows immediately.

Equations (1) state that at any instant the number of atoms present is proportional to the period, or, alternatively, to the

average life ; thus the very active elements exist only in extremely small quantities. Those who wish for further evidence in addition to that furnished by the condition of radioactive equilibrium will find a demonstration in the footnote.*

If radium is being destroyed continuously, how can there be any in existence now? Geology has shown, in various ways, that the earth has existed for hundreds of thousands of centuries ; therefore if radium is transformed into helium and emanation, how can any radium exist to-day on the earth ? The theory of disintegration replies to this question by pointing to an element, further back, which forms radium continuously and so replaces it as rapidly as it disappears ; this ancestor of radium is uranium. This element must have an extremely slow rate of disintegration so that it may have been able to generate radium continuously throughout the periods of time indicated by geological science.

Let us consider the fundamental law of radioactive equilibrium :

$$\lambda_1 N_1 = \lambda_2 N_2 = \lambda_3 N_3 \dots$$

In two successive disintegrations (whether these be consecutive or not is immaterial) of which the second is more rapid than the first, the body which is transformed more quickly (radium) accumulates until the ratio, N_2/N_1 , between it and the parent body reaches a fixed limiting value which is equal to the ratio of the average lives. The quantity of radium in uranium minerals must,

* Let N_0 be the number of atoms of the primary substance A which are originally present. At time t the number of atoms present will be $N_A = N_0 e^{-\lambda_A t}$.

The rate of production of B is equal to the rate of destruction of the parent substance, less the rate of destruction of B itself, so that

$$\frac{dB}{dt} = \lambda_A N_A - \lambda_B N_B = \lambda_A N_0 e^{-\lambda_A t} - \lambda_B N_B.$$

This equation gives N_B as a function of the time, and, assuming that only the substance A was present originally, it is found that

$$N_B = \frac{\lambda_A N_A}{\lambda_B - \lambda_A} [1 - e^{-(\lambda_B - \lambda_A)t}].$$

Now if λ_A is much smaller than λ_B , *i.e.*, if the primary element disintegrates much less than the element it gives rise to, the exponential term becomes negligible, and the above expression reduces to $N_B = N_A \lambda_A / \lambda_B$, as has been stated.

therefore, reach a fixed proportion of the quantity of the parent element; this ratio is independent of the mineral. Several physicists have examined a large number of uranium minerals; it has always been found that there is the same ratio between the quantities of radium and uranium present; Rutherford and Boltwood in particular have determined the exact value of this ratio and have found that, for every gramme of uranium, there is present 3.4×10^{-27} gm. of radium; this figure, then, gives the ratio of the transformation constants and, therefore, also the ratio of the average lives, since this latter ratio is simply the reciprocal of the former; the average life of uranium is thus found to be about 6,000 million years.* Soddy, who measured the rate of production of helium from uranium, using a *direct method*, found the same result.

The Production of Helium—The Heat Liberated

Helium was not discovered on the earth but in the sun; it was in 1868 that Jansen and Lockyer observed in the spectrum of the chromosphere a yellow line which could not be identified with any of the lines of the known terrestrial elements.

It is known that helium is devoid of chemical properties, *i.e.*, it has no chemical affinity. The ratio of its specific heats at constant pressure and at constant volume indicate that it is a monatomic gas; in 1908 it was liquefied for the first time; at -269° it boils at ordinary pressure. It was also solidified by Keesom, in the laboratory of the University of Leyden.

Precise measurements by Rutherford have shown that 156 cub. mm. of helium are formed per annum from 1 gm. of radium; one of the methods of obtaining this figure is to make a direct count of the number of α -particles emitted in a given time from a known quantity of radium.

It is, however, not only in the production of helium that radioactive substances exhibit a property which is entirely new and

* The following are the details of the calculation: the atomic weights of uranium and of radium are respectively 238 and 226, so that, in radioactive equilibrium, for every n atoms of uranium there are $n \times 3.4 \times 10^{-7} \times (238/226)$ atoms of radium. The period of radium gives, therefore, the period of uranium when divided by 3.6×10^{-7} .

disturbing to the classical physics ; there is also the phenomenon of heat production which is equivalent to the liberation of enormous quantities of energy and which, at first sight, seems to be continuous.

The heat given off in one hour from 1 gm. of radium in equilibrium with its short-life products is about 135 calories, and this means that radium gives off every hour enough heat to melt a quantity of ice greater than its own mass.

Rutherford (1904) showed that this heat comes almost entirely from the conversion into heat of the kinetic energy of the α -particles. Two glass bulbs filled with dry air, were connected by a U-tube containing a liquid so as to act as a differential manometer. A sealed tube of glass containing radium bromide was placed in one bulb, and the heat produced caused an increase of pressure in this bulb ; the manometer indicated this effect, and the total heat was measured by comparing it with the (readily calculable) heat emitted from a coil of wire through which an electric current was passing. Knowing the intensity of the current, as indicated by a galvanometer, and the specific resistance of the material of the coil, the quantity of heat could be found at once.

Separate measurements were then made of the heat liberated from the radium salt from which the emanation had been removed, and of the heat liberated from the emanation so removed.

The total energy emitted in the *complete* transformation of a gramme of radium into helium and lead can be deduced from a measurement of this kind by simple computation ; it is 3.7×10^9 calories, or 1.5×10^{17} ergs.

Compared with the energy liberated during chemical reactions, the energies met with in radioactive transformations are enormous ; one of the most exothermic chemical reactions is the combustion of hydrogen ; now one cubic centimetre of a mixture of hydrogen and oxygen, when exploded to form water, liberates only two calories ; hence an equal volume of radium emanation can emit, during its whole life, a quantity of energy which is 12 million times as great as that given out during the explosion of the mixture of hydrogen and oxygen.

A single gramme of radium, during the course of its transformation into helium and lead, gives off as much heat as the combustion of 500 kg. of coal !

The Discovery of Isotopes

As the radioactive elements were discovered, the question arose as to how they should be placed in the periodic classification, and two difficulties presented themselves. One was due to the fact that most of the radioactive elements were only obtainable in small quantities so that it was not possible to use ordinary methods for determining their chemical properties and so to discover their natural places in the classification. The other difficulty, which was of quite a different kind, was that at the time of the discovery of radium there were only seven places available in the lower part of the table representing the periodic system, while the number of elements to be inserted was about thirty.

The problem was solved by the discovery of a totally unforeseen fact ; it was found that certain radioactive elements, in spite of the fact that they had different atomic weights, had absolutely identical chemical properties so that it was impossible to separate them by the methods of chemical analysis. Such a case, for instance, is that of radium D and lead ; when lead is extracted from a mineral containing uranium it shows a certain amount of radioactivity due to the small quantity of radium D which it contains, this radium D having been formed, as we know, by the disintegration of radium emanation.

All possible means for separating the two elements were tried without success, including fractional precipitation, evaporation, and oxidation ; the two elements were found to be identical in their chemical properties.

It was the discovery of a connection between the nature of the α -, β - or γ -rays emitted during a radioactive transformation and the change of position in the periodic table caused by the transformation that solved the problem. Soddy, Russell and Fajans, almost simultaneously and independently of one another, enunciated in 1913, the following well-known law : *in every radioactive transformation in which α -rays are emitted, the element*

is displaced two spaces (columns) in the direction of decreasing atomic weights, i.e., the atomic number is diminished by two. This number, however, increases by one when β -rays are emitted. The alteration of the atomic number is due to the fact that when

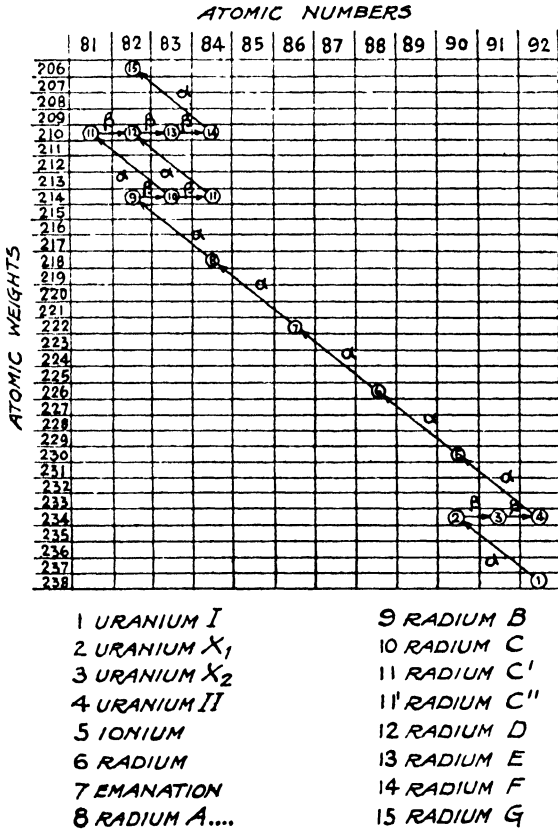

FIG. 99.—Uranium and its products.

the nucleus * loses a negative charge, the residual charge is increased by one and the atom therefore captures an electron which takes its place in the system surrounding the nucleus ; consequently the atomic number is increased (see Fig. 99).

* We shall deal with the nucleus more fully in Chap. IX ; it is the central part of the atom and has a positive charge which is balanced by the electrons surrounding it.

It is a simple matter, by means of this "displacement law," to classify the elements of which it is not possible to establish the chemical properties by any direct method; thus all the radioactive elements have found a place in the periodic system, some in the positions which were not already occupied, others in positions occupied by elements which had long been known (bismuth, lead, thorium). In the place occupied by lead, which has an atomic weight of 207.2, there fell also radium G (206), thorium D (208.4), radium D (210), actinium B (210), thorium B (212.4), and radium B (214).

As long as isotopes were confined to the radioactive elements, the atomic weights of which could not be determined except by calculation and which could only be obtained in very small quantities, the importance of this new principle was much restricted; but it was soon directly demonstrated that in the case of ordinary elements, too, a difference of atomic weight did not necessarily involve a change of properties. It had been noticed, from 1905 onwards, that lead was always found in uranium minerals, and that the amount was greater in proportion to the geological age of the mineral; the hypothesis was therefore put forward that lead was formed by the disintegration of uranium. Now radium G, the final term in the uranium series, is formed from this element after the successive expulsion of 5 α -particles, and therefore must have an atomic weight of $226 - (5 \times 4) = 206$; the atomic weight of lead, however, is 207.2; now by the displacement law, radium G should occupy the same position as ordinary lead; it was to be expected, then, that the atomic weight of the lead contained in uranium minerals would be less than that of ordinary lead, and accurate researches carried out from 1914 onwards by Madame Curie and other physicists have fully justified this expectation.

The preparation of isotopes in measurable quantities has enabled their properties to be minutely compared. Experiments have shown that not only the chemical properties but also some of the physical properties are absolutely similar; for instance, it has been found impossible to detect the slightest difference

between lead and radium G, whether as regards melting-point or volatility, magnetic susceptibility, refractive index of solutions of the salt, etc. Further, the spectra show no appreciable differences.* The only physical properties which can be different for different isotopes are those which depend on the atomic mass, and the atomic volume; the velocities of diffusion of two isotopes (existing in the gaseous state) through a porous diaphragm should be different because this quantity depends on the atomic density. This has actually been found to be the case.

The discovery of the existence of isotopes among the radioactive elements caused a revival of the hypothesis, originally proposed some twenty years previously by Crookes, that the ordinary elements were also composed of mixtures of isotopes, and that this explained the variation found among the atomic weights which, although not exact multiples of the atomic weight of hydrogen, were not very far removed from such multiples; a suitably proportioned mixture of atoms having integral atomic weights (*e.g.*, 10 and 11) would account for a fractional atomic weight such as 10.9. It was, however, necessary to admit that if an element was really composed of different atoms, unless they always occurred together in exactly the same proportions, small fluctuations would be found in the atomic weight, according to the particular source from which the element was obtained. Very careful researches were carried out on chlorine derived from various sources differing both geographically and geologically; iron from meteorites was compared with terrestrial iron, but no difference in the atomic weights was detected, within the limits of experimental error. This would have caused the idea to be abandoned had not J. J. Thomson, just at the time when the discovery of isotopes among the radioactive elements had revived Crookes' hypothesis, devised the method of analysis described on p. 198, *i.e.*, the method of separating isotopes by means of the deviation produced by a magnetic and an electric field on a narrow beam of canal rays.

It was in 1913 that Thomson and Aston made their startling

* Except, as will be noted at the end of Chap. II. of Vol. II, when dealing with molecular spectra.

discovery, separating atmospheric neon (20·20) into two neons having the atomic weights 20 and 22.

If neon was a mixture of two gases it should be possible to separate them. Aston undertook the work, but performed thousands of fractional distillations without any result ; six years later, however, Aston published the results of his famous researches which had been interrupted by the war, and showed that of the 29 elements studied, 18 had proved to be mixtures. This has already been mentioned.

Various methods have been devised for the separation of isotopes, such as evaporation at low pressure, diffusion through a porous septum, centrifuging, etc. ; they are all founded on the different atomic *masses* of the isotopes, and are very slow and laborious ; we have already mentioned that Brönsted and Hevesy have succeeded in the case of mercury in obtaining, by means of successive evaporations, two portions having slightly different densities.

These facts necessitated a revision of certain fundamental ideas in chemistry ; in fact, the principle of an unique relationship between the atomic weight and the properties of an element, the principle on which Mendeleieff founded the periodic classification, was very severely shaken ; actually it was found that elements could have different atomic weights without their chemical properties being noticeably altered, and, on the other hand, elements which were isobares had the same atomic weight but showed totally different properties.

The properties of an element, then, are not governed by the atomic weight, but depend solely on the position occupied by the element in the periodic table, and this position, as far as we have gone into the subject up to the present, is decided solely on the basis of Moseley's discovery, and less precisely on the properties of the element.

We shall see, however, in the following chapter, how *the atomic number of an element actually has a fundamental significance*, since it corresponds to a basic characteristic of the atomic structure.

The *final product* of all three transformation series (uranium,

actinium and thorium) is an isotope of lead. Consequently both in uranium minerals and in thorium minerals, appreciable quantities of lead are accumulated during the passage of the centuries, and there is thus a possibility of arriving at some estimate of the age of geological formations by analysing the composition of the minerals they contain. From n atoms of uranium, the number disintegrating each year is $15n \times 10^{-10}$; the ratio of the atomic weights is 206 (lead)/238 (uranium), so that a gramme of uranium produces annually 1.3×10^{-10} grammes = $1/(8 \times 10^9)$ grammes of uranium lead.

It will be understood, then, how it is possible to obtain the approximate age of a mineral by multiplying by 8,000 the quantity of uranium lead (in grammes) corresponding to one gramme of uranium. For instance, a 10 per cent. lead content indicates an age of 800 million years.

Path of the α -Particles ; Geiger's Law

Any given radioactive substance emits α -particles, all of which have the same initial velocity; this velocity diminishes as the particles lose their energy in ionising the gas they pass through, and when their velocity has been reduced to a certain definite value, they are no longer able to produce any further ionisation; the region of ionisation is limited to a certain distance called the *path*. Any screen which reduces the velocity also reduces the path in the gas by an amount which depends on the density of the screen and on the atomic weight of the substance of which it is composed. These are Bragg's conclusions, resulting from some elegant experiments.

In one of these, Bragg took a glass bulb (Fig. 100) 16 cm. in diameter, coated internally over the upper hemisphere with zinc sulphide which—as is well known—is one of the substances which show up the presence of α -particles.

At the centre of the bulb, Bragg placed a small tube containing radium; when the apparatus was viewed in the dark, as long as the bulb was full of air very little luminescence could be detected, since the 8 cm. of air were sufficient to stop the α -particles, while the β - and γ -rays from a small quantity of radium only produced

a very slight effect. When, however, the bulb was connected to a vacuum pump, so as to extract the air from it, a bright luminescence immediately appeared.

The velocity of the α -particles varies from one substance to another, as has been said, and the path of a particle in air is therefore a characteristic of each radioactive element. It has been found, by the use of the scintillation method, that the number of the α -particles remains sensibly constant when screens are interposed in the path of the rays, so long as these screens are of a thickness sufficient to reduce the length of the path of the particles in air without stopping them altogether; in fact,

they are not absorbed but merely slowed down, so long as the initial velocity is sufficiently great; the β -rays, on the other hand, behave quite differently and suffer a progressive absorption within the material.

In air under ordinary conditions, the path of the α -particles is from 2.7 to 11.3 cm.; in hydrogen, the fastest α -particles travel a distance of 24 cm. A sheet of aluminium 0.06 mm. thick completely stops even the fastest particles, while the β -rays pass through an aluminium plate several millimetres thick.

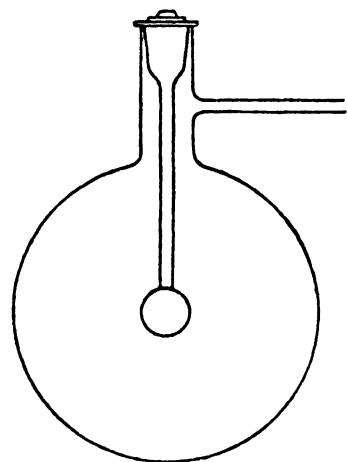

FIG. 100.

The three properties (*a*) ionising power, (*b*) photographic effect and (*c*) production of luminescence, disappear simultaneously when the velocity of the α -particles, after they have travelled their characteristic length of path, falls below a certain critical velocity which is about 6,000 km. per second.

The ionising power of the α -particles does not, as might be thought, increase as their velocity increases; on the contrary, it rises in the final section of the path, *i.e.*, when the velocity has fallen and then drops suddenly to zero at the end. The energy of a particle is $\frac{1}{2}mv^2$ and is comparatively large, owing to the high value of v ; for radium C', for instance, this energy amounts

to 1.31×10^{-5} crgs; v , as has been said already, is about 20,000 km. per second.*

Every α -particle emitted during the course of a given radioactive transformation travels exactly the same distance before it disappears and, as Rutherford has shown by direct measurements of the magnetic and electric deviations, it is emitted with a certain definite velocity. The following are the data for the α -particles given off during the course of the complete disintegration of uranium :—

α -particle.	Velocity in km./sec.	Path in mm. in Air at Ordinary Pressures.
Uranium I . .	14,700	25
Radium . . .	16,000	32
Emanation . .	17,400	40
Radium C' . .	19,200	66

This path, which has a characteristic value for each element, is also called the *range*; the higher the velocity of emission, the greater the range of the α -particle; more precisely, the range in any gas is proportional to the cube of the initial velocity v (Geiger's law).

The same relationship exists between the distance which has yet to be traversed by the particle at any given instant and the residual velocity at that instant. The range R in air at normal pressure and at 0° C. is therefore a characteristic of a radioelement, and is given (in centimetres) by

$$R = 8.6 \times 10^{-28} v^3 \quad . \quad . \quad . \quad (1)$$

A simple relationship discovered empirically by Geiger and

* The velocity of the fastest β -particle is some fifteen times as great as this, but the mass is smaller in the ratio of 1 to 7,000. Even allowing for the fact that, at a velocity equal to 99.8 per cent. of the velocity of light, the mass of the electron must be taken as $16m_0$, the kinetic energy of even this exceedingly fast β -particle is still much less than that of an α -particle.

Nuttall* in 1911 connects the path of the α -particle with the half-period of the element emitting it; it was noticed, in fact, that if the logarithms of the ranges R for any given series (*e.g.*, radium A, emanation, radium F, ionium, uranium) were plotted as abscissæ against the logarithms of the corresponding transformation constants λ as ordinates, then a *straight line was obtained* for each of the three series, so that

$$\log \lambda = A + B \log R \quad . \quad . \quad . \quad . \quad . \quad (2)$$

Since, moreover, the three straight lines are parallel, it follows that B is a universal constant having the value 53.9; the value of the constant A is different for each of the three series and for the radium series $A = -37.7$. The above value of B , given by Hevesy and Paneth, indicates that the transformation constant λ ($dN = -\lambda N dt$) varies as the 54th power of the range of the α -particle emitted.

Equation (2) is not, however, rigorously true; nevertheless, its importance as a link between the different radioactive elements can be readily appreciated.

We shall see in Vol. II, Chap. VIII that the new mechanics has provided a basis for a theory of radioactive disintegrations which, although it is purely formal, nevertheless explains how it may happen that an α -particle which remains attached to a nucleus for years and even for centuries may suddenly be expelled without any apparent reason.

In this way a theoretical explanation was found in 1928 for Geiger and Nuttall's important rule.

The number of pairs of ions, k , produced by an α -particle in air is proportional to the initial kinetic energy, and since the initial velocity v is proportional to $R^{1/3}$, the number of ions varies as $R^{2/3}$. For radium C' it is found that $k = 6.25 \times 10^4 \times R^{2/3}$, and thus it will be seen that every α -particle produces 220,000 pairs of ions. The ionising effect of the β -rays is much less;

* H. Geiger and J. M. Nuttall, *Phil. Mag.*, 22, p. 613, 1911, and 23, p. 439, 1912. R. W. Gurney and E. U. Condon have given a theoretical explanation of Geiger and Nuttall's relationship on the basis of wave mechanics (*Phys. Rev.*, 33, p. 127, 1929).

when the β -radiation is completely absorbed in air, each of the fastest particles produces about 10,000 pairs of ions.

Paths of Certain α -Particles in Air at 760 mm. pressure, Initial Velocities and Amount of Ionisation Produced.

	Path in cm		Velocity in cm/sec.	Number of pairs of Ions produced in Air.
	At 0° C.	At 15° C.		
Ionium	3.02	3.19	1.48×10^9	1.46×10^5
Radium A	4.47	4.72	1.69×10^9	1.87×10^5
Thorium	2.75	2.90	1.43×10^9	1.37×10^5
Thorium C'	8.17	8.62	2.06×10^9	2.74×10^5

Weight, in mg. per sq. cm., of Metal Foils Equivalent, in Stopping Power for α -Particles, to 1 cm. of Air at 15° C.

	Atomic Weight.	Weight of Foil.
Aluminium	27.1	1.62 mg./cm ² .
Copper	63.6	2.26 "
Silver	107.9	2.86 "
Tin	118.7	3.17 "
Gold	197.2	3.96 "

The Path of Each Atomic Projectile may be made Visible—Photography of the Trajectories—C. T. R. Wilson.

By means of the scintillation effect we can observe the impact of every atom of helium formed out of an α -particle as it strikes a fluorescent screen; the path followed by the atom would, however, be unknown to us if C. T. R. Wilson had not, by means of his wonderful experiments, found a means of causing the particle to leave a trail of visible ions behind it as it travels along its path.

An imperceptible trace of fluoride of radium on the end of a thread is placed in a glass vessel containing air saturated with water-vapour; a sudden lowering of the pressure produces

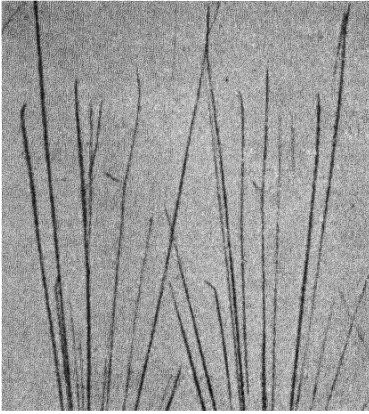

FIG. 101.

supersaturation by cooling; the ions produced by the collisions of the α -particles which disintegrate the molecules by their impacts, become centres upon which the water-vapour condenses. Each particle leaves behind it a trail of ions; immediately after the expansions, the glass vessel is illuminated by means of a lamp and the lines of droplets thus made visible are photographed (see Fig. 101).

The expansion chamber has glass walls, and so is transparent.

The paths are rectilinear and diverge from the particle of active material; they are not absolutely straight lines, but begin to exhibit a curvature for the last few millimetres before the end, as shown in Fig. 102; sometimes they show sharply defined "spurs." These noticeable peculiarities can be interpreted completely; they represent, as we shall see, collisions with the nuclei of the atoms encountered. We shall return to this point when we are dealing with the constitution of the atom in the following chapter.

By the same method, Wilson has also made the tracks of the electrons forming the β -rays visible; we may, in fact, say that Wilson's experiment has inaugurated a new era and its applications are manifold; it has now become almost a commonplace, and several manufacturers make the necessary apparatus.

The β -rays, their Velocity and Ionising Power

The paths of the β -rays have also been studied, and the characteristic employed in

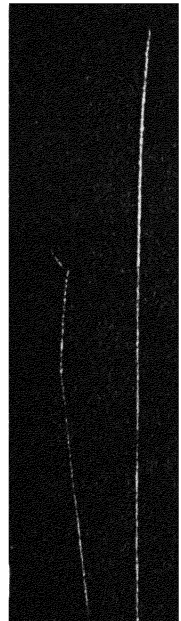

FIG. 102.

this case is the penetrating power of the rays, expressed in terms of thickness of aluminium; several elements give rays which seem to possess not one but various absorption coefficients, and therefore it may be concluded that, unlike the α -radiation, the β -radiation is composed of rays of different velocities.

This fact is shown still more clearly by means of Kovarik's magnetic spectra; these are based on the deviations which electrons of different velocities undergo in a magnetic field. If a beam of β -rays, composed of electrons of several velocities, be

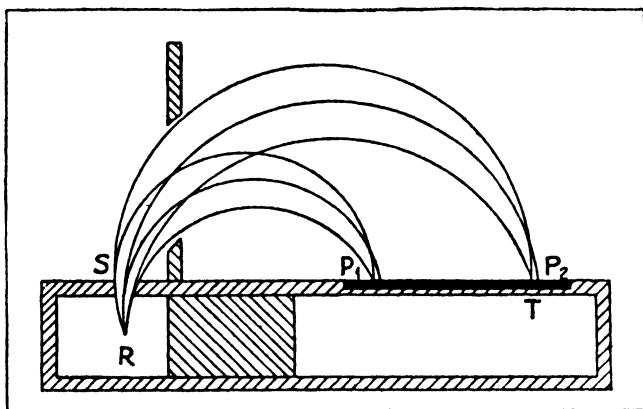

FIG. 103.

acted upon by a magnetic field perpendicular to the plane of the paper (see Fig. 103), the beam is dispersed and produces on the photographic plate $P_1 P_2$ a series of black lines which together make up a *magnetic spectrum*, every line corresponding to one emission velocity. As we shall indicate later, this method brings out the fact that some of the β -particles are primary (emitted from the nucleus) while others, on the contrary, are secondary, *i.e.*, they are emitted from the external shell of electrons by the action of the γ -rays.

The velocities of the electrons measured in this way extend from 9.9×10^9 cm. per second to 2.99×10^{10} cm. per second, *i.e.*, from 33 to 99.8 per cent. of the velocity of light. The fastest β -particles were found in the case of radium C.

By means of an electroscope it is possible to measure the total

charge of an element radiating β -particles, and hence the unit charge is known by calculation from the number of transformations taking place per second.

After we have described the photoelectric effect (Vol. II, Chap. V), we shall be able to explain the primary and secondary β -radiation, and we shall then be in a position to describe how it is possible to measure the wave-lengths of the γ -rays which cannot be measured by means of crystals on account of their excessive smallness.

Radioactive Transformations have provided various Methods for finding Avogadro's Number

Since it is possible to count the number of α -particles emitted per second from a radioactive body, the number of atoms in the mass of helium so generated is known, and as this latter quantity may be determined by measuring its volume at a known temperature and pressure, it is possible in this way to determine N , *i.e.*, the number of atoms in a gramme-molecule of helium.

By Avogadro's law this number is the same for all bodies.

The difficulty in this method lies in collecting the very small quantities of helium produced, and in excluding other gases.

Precise measurements, due to Rutherford's experimental genius, have established the fact that one gramme of radium gives 156 cubic mm. of helium per annum; after allowing for the successive disintegrations, it is found that 39 cubic mm. are due to the radium alone. Since the number of atoms of helium shot off per second is 34,000 millions, the number of monatomic molecules formed in a year will be $34 \times 86400 \times 365 \times 10^9$.

A cubic cm. of helium, therefore, contains $(34 \times 86400 \times 365 \times 10^9) / 0.039$ atoms, and since the gramme-molecule of every gas occupies 22,400 c.c., the value of N is found at once to be 61×10^{22} .

Radioactive substances provide two further methods for determining Avogadro's number; in the case of radium, for example, the atomic weight (226) is well known, the number of α -particles emitted per second from a gramme is also known to be 34×10^9 , and the radioactive constant expressed in terms of the year as unit of time has been determined. From this latter figure, taking account of the number of seconds in a year, it can easily be

calculated that out of N atoms of radium, $N \times 12 \times 10^{-12}$ explode in every second.

Thus the following equation results :

$$226 \times 34 \times 10^9 = N \times 12 \times 10^{-12},$$

where the left-hand side represents the number of atoms transformed in every 226 grams, while the right-hand side represents the number transformed out of the N atoms constituting the gramme-molecule—which is the same thing.

This gives $N = 64 \times 10^{22}$.

Finally, another equation can be established between the quantity of heat developed and the kinetic energy of the α -particles ; this represents, without any appreciable error, the total quantity of energy which can be obtained from the radiation ; since a number of recent measurements have shown that the total energy developed by radium is about 135 calories per gramme per hour, the equality between the heat developed and the kinetic energy of the particles may be written as follows :—*

$$\frac{135 \times 4.18 \times 10^7}{3600} = \frac{1}{2} \cdot \frac{34 \times 10^9 m}{N} (u_1^2 + u_2^2 + u_3^2 + u_4^2)$$

where m is the mass of the atom of helium, viz., 4, and u_1, u_2, u_3, u_4 are the initial velocities of the four α -rays emitted from radium and its products in equilibrium. These have been determined by Rutherford, and are as follows :—

from radium	$u_1 = 16,000$ km./sec.
from emanation	$u_2 = 17,400$,,
from radium A	$u_3 = 16,900$,,
from radium C'	$u_4 = 19,200$,,

By means of the equation written above, the value of N can at once be determined, and is found to have an approximate value of 60×10^{22} .†

* The factor 4.18×10^7 converts calories to ergs.

† An exact value cannot be obtained since a certain fraction of the energy, although not a large one, is due to the β - and γ -rays. More exactly, 90 per cent. is due to the α -particles, 3.4 per cent. to the β -rays, 4.7 per cent. to the γ -rays and 1.8 per cent. to the *recoil atoms*. These latter are the atoms which, on the expulsion of an α - or a β -particle, experience (according to the law of conservation of momentum) an impulse which is equal and opposite to that of the particle expelled.

Total Energy liberated from Radium—The Internal Energy of Matter

The outstanding and most striking fact of radioactivity is the continuous emission of energy ; a gramme of radium element liberates about 135 gramme calories per hour, or a million calories in a year.

In the total transformation, 3,700 million calories are developed ! The energy liberated in the disintegration of radium is of the order of a million times that given by an equal weight of matter in the most violent of chemical reactions ; the combustion of a gramme of carbon, for instance, produces only about 8,000 calories, but in this reaction the carbon combines with $\frac{32}{12}$ grammes of oxygen so that only 2,200 calories are liberated per gramme of matter involved in the reaction. It will be seen, therefore, that the energy of radium is more than a million times as great as that liberated during the combustion of carbon.

Is it not wonderful to think that in a hundred grammes of uranium, a common element which is produced annually in scores of tons, there should lie dormant, and awaiting liberation, an amount of energy equal to that given by the combustion of 40 tons of carbon ?

This energy would be worth vastly more than the uranium itself if man were able to make it available ; unfortunately we of this present age are, as regards this problem, in exactly the same state as was primitive man with regard to fire at the dawn of human existence ; we are still passive and impotent spectators in face of the imposing and mysterious phenomenon of radioactivity, and the existence of this colossal reserve of energy at nature's disposal remained unknown and even unsuspected until Becquerel's discovery.

Why is it that the spontaneous disintegration, which we see taking place in the case of some of the heavier elements (in which the complex structure of the atom seems to be the cause of the transformation), does not occur equally in the other heavy elements such as lead, bismuth, mercury, gold and platinum, for

their atoms are only slightly lighter than those of uranium or radium, and yet they do not undergo any transformation ?

From the solely chemical point of view there is such a complete parallelism between the radioactive and the non-radioactive elements that it would not be possible to distinguish the former if it were not for the fact that they give off energy at a perceptible rate, while the latter keep it latent. Radium in particular so closely resembles non-radioactive elements (barium, strontium and calcium), both in its chemical properties and in its spectrum that chemists place it at once in the family of the alkaline earths.

Our inability to make use of the immense reserves of energy stored up within the various radioactive substances arises from the fact that we have not succeeded in discovering any controlling influence which will hasten the process of emission ; the highest temperatures and the most extreme cold, the greatest pressures, the most violent chemical reactions, even the action of the most intense electrical discharges have no effect whatever on radioactivity or on the rate at which transformation takes place. Man, as has been said, is reduced to the position of a powerless spectator in face of a phenomenon of which he knows the effects and the guiding laws, but of which the primary cause is hidden from him.

The complete Spectrum of the Ether Waves

Now that, besides the X-rays, we have met with the γ -rays resulting from radioactive disintegrations, we are in a position to put together a complete picture of all the vibrations in the ether, from the waves used in radiotelegraphy to the extremely penetrating radiations having frequencies of the order of 10^{23} .

The diagram on p. 324 is by Prof. Quirino Maiorana, the celebrated scientist of the University of Bologna.

To comment fully on this would take too long, and we will here restrict ourselves to drawing attention to certain ranges of frequency, and particularly to that linking the infra-red radiation (studied by Mellioni) to the electromagnetic radiation ; this has been the subject of work by several physicists who have explored different zones within this region ; that in the neighbourhood of

RADIOACTIVITY

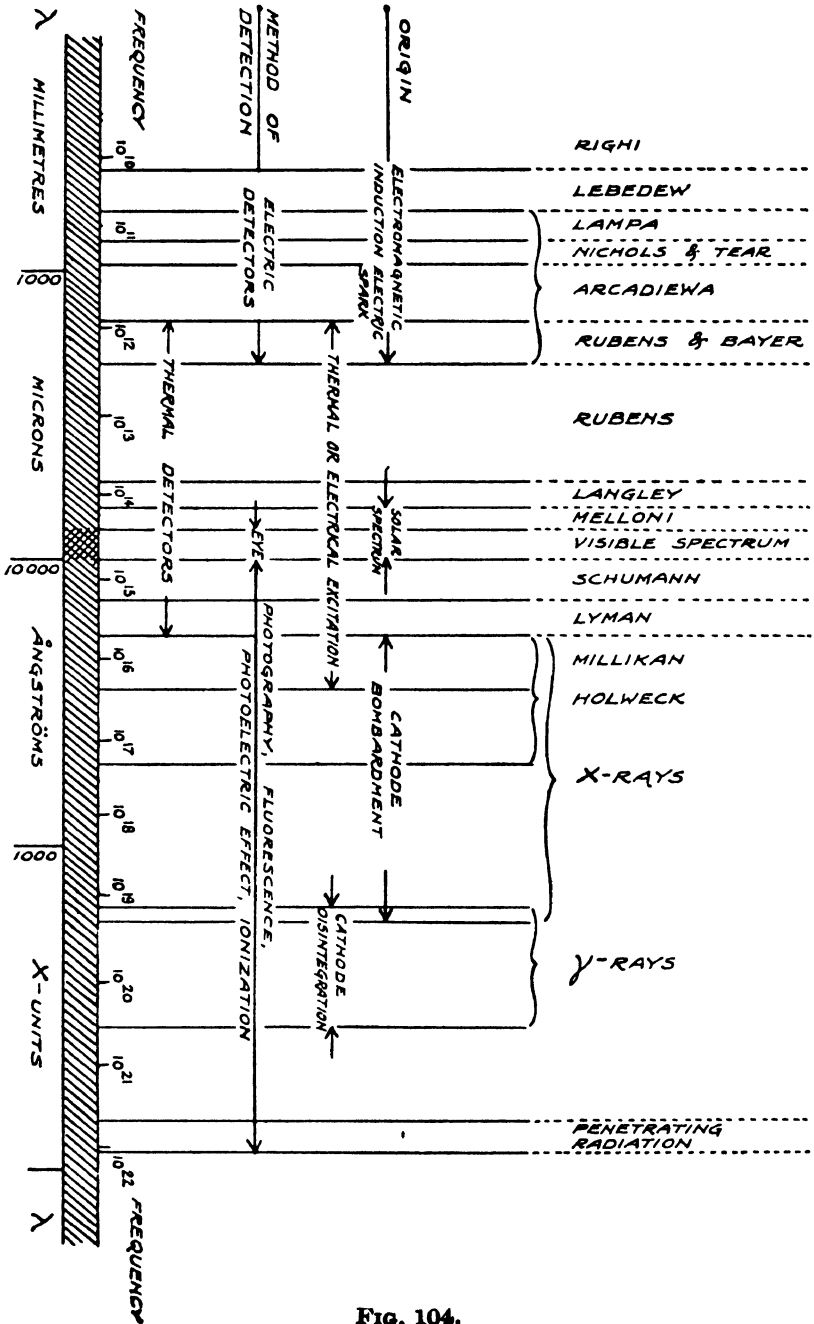

10^{11} was studied by two Americans, Nichols and Tear (1928). The interval which remained to be filled in, between the wave-lengths of 1.8 mm. and 0.31 mm., was explored by Madame Arcadiewa in 1925, so that there is no longer any gap between visible light and the electric waves.

At the high frequency end, beyond the ultra-violet rays of Schumann and Lyman, we find first of all the X-rays with comparatively long wave-lengths, and with these Millikan's name is particularly associated. Until 1922 there was still an interval between 136 Ångström and 12 Ångström units within which no radiation had been observed; Holweck's researches enabled this gap to be filled.

Finally we come, after the vast range covered by the X-rays and the γ -rays, to the new penetrating radiations studied during the last few years, especially by Millikan. These have a frequency of about 10^{23} .

The complete picture of the ether waves demonstrates the existence of a wonderful unity among the various forms of radiant energy; actually, though the variety of the effects apparent to man is very great, and though the methods of detecting them are various, the nature of all these oscillations is the same, the laws which they obey apply to all alike, and there is no discontinuity between the waves of radiotelegraphy for which λ is equal to several hectometres, and Millikan's ultra-penetrating radiation for which λ is of the order of 10^{-13} cm.

But the human intellect can never be satisfied completely; besides these radiations—considered always to have a vibratory origin—in which the characteristic of periodicity seems evident, there is another group of radiations of a totally different kind; there are corpuscular radiations, and in this group are placed the cathode rays, the canal rays, the α - and the β -rays; if these latter forms of radiant energy have characteristics in common with the others, how can there be a chasm between them so that the former must be considered exclusively as an undulatory phenomenon while the latter are regarded solely as a stream of particles?

Are there no phenomena in which Physics finds itself confronted with a corpuscular characteristic of the ether waves and, *vice versa*, with an undulatory characteristic of the corpuscular radiations ?

These phenomena, as we shall see later, do really exist.

In Vol. II, Chap. VI, we shall find that the Compton effect indicates that light has a distinctly corpuscular characteristic, for this phenomenon appears to result from the impact, with the electrons present in matter, of light particles containing an amount of energy which bears a simple and unique relationship to the frequency of the light ; further, in the course of the collisions these particles obey the two laws of the conservation of momentum and of the conservation of energy, exactly as is the case in a collision between elastic spheres. In the photo-electric effect, too, and generally in cases where there is reaction between energy and matter, light behaves as if it were composed of " grains " to which physicists have given the name " photons."

Conversely, in certain experiments like those of Rupp, Davisson, Germer and G. P. Thomson (which we shall meet with in Vol. II, Chap. VIII), a stream of material particles (atoms or electrons) behaves as if it has certain characteristics appropriate to a wave-motion, viz., interference and diffraction similar to that found in the case of light. Thus during the last few years the fact that there is a close relationship between light and matter has become more and more apparent.

BIBLIOGRAPHY

- J. CHADWICK. " Radioactivity and Radioactive Substances " (1921).
 K. FAJANS. " Radioaktivität " (1922). (English translation by T. S. Wheeler and W. G. King.)
 G. V. HEVESY and F. PANETH. " Lehrbuch der Radioaktivität " (1923). (English translation by R. W. Lawson.)
 E. RUTHERFORD. " Radioactive Substances and their Radiations " (1920).
 F. SODDY. " The Chemistry of the Radioelements " (1914).
 E. N. DA C. ANDRADE. " The Structure of the Atom " (1927).
 H. WILSON. " Modern Physics " (1928).
 C. T. R. WILSON. " Investigations on X-rays and β -rays by the Cloud Method," *Proc. Roy. Soc.*, 104, pp. 1 and 192, 1923.
 " Elektronen, Atome, Moleküle," with a complete bibliography, *Handbuch der Physik*, Vol. XXII., 1926.
 M. HAISSINSKY. " L'Atomistica Moderna e la Chimica " (1930).
 K. W. F. KOHLRAUSCH. " Radioaktivität " (1923).
 E. RUTHERFORD, J. CHADWICK and C. D. ELLIS. " Radiations from Radioactive Substances " (1931).

CHAPTER IX

THE ATOMIC NUCLEUS

A Master of Atomic Physics : Rutherford

THE study of the physical and chemical properties of bodies has brought to light the existence of the atom ; the cathode rays have made known the existence of the electron ; the X-rays have revealed the complex nature of the atom and shown that it is capable of giving spectra, while radioactivity has confirmed this idea and has brought us back again to the electron ; radioactivity and relativity together, in the transformation of one element into another, teach us that matter is a storehouse of energy.

In the electrical discharge through rarefied gases, in the rays emitted from the radioactive elements, in the emission from incandescent bodies we have seen the β -particle leave the matter of which it is a constituent ; the positive part of the atom, on the other hand, has been met with in the canal rays. Prout's law, the Soddy-Fajans law, the emission of α -particles, isotopes, and Moseley's law have indicated certain ideas as to the constitution of matter, but they are as yet purely tentative so far as the structure of the atom is concerned ; this structure is certainly complex, as was indeed demonstrated long ago by the optical spectra of the elements.

Nevertheless, all that has been explained so far is insufficient to indicate the structure of the atom, and it is not yet clear how these results can be brought into harmony so as to present us with a model structure which will give an interpretation of all the facts.

However, before all that is known to-day had been discovered, a giant among physicists, Rutherford of Cambridge, had described

a rough plan of the structure of the atom, basing his ideas on the passage of α -particles through matter.

The Passage of α -Particles through Atoms

C. T. R. Wilson, by means of his famous photographs, gave a direct proof of the fact that the α -particles, which are atoms of helium shot off at enormous velocities of 15 to 20 thousand kilometres per second, do actually pass through the atoms as they travel in straight lines through seven centimetres of air at atmospheric pressure. These particles ionise such a large number of the atoms which they meet in their path that the droplets of water formed on the ions produced along the path—and it is these that are really photographed—cannot be distinguished individually.

The sudden changes of direction which appear at the end of the path, the so-called *bends* or *hooks* (see Fig. 102), clearly prove that the particles really pass through the atoms instead of swerving from them sideways like a cannon ball. Actually, when a heavenly body, moving at a very high speed, passes through a solar system without striking the central mass, it does not depart perceptibly from the straight line path which it was following when it *entered* the system, so long as its velocity is sufficiently high; this is for the simple reason that it is within the zone where the deflecting force is great for so short a time that the path cannot undergo any noticeable deflection; if, however, the velocity is smaller, the deflection becomes considerable, for then the integral of *the force with respect to the time of action*—and therefore the corresponding quantity of motion—becomes noticeable.

It is for this reason that when the α -particle, after having passed through several centimetres of air, is slowed down towards the end of its journey, it becomes noticeably deflected at an angle depending on the circumstances prevailing. During the course of its passage through seven centimetres of air, every α -particle must pass through 130,000 molecules; if it did not pass through them but only struck them laterally like a cannon-ball, it would necessarily meet with greater resistance the greater

its velocity ; now it is found that the facts are exactly contrary to this, for the α -particle produces more ionisation over the latter part of its path than over the initial part, showing that it loses its energy more quickly when it moves more slowly. Everything takes place as if the α -particle actually passed through a miniature solar system of which the constituent bodies are very small in comparison with the dimensions of the whole system.

That the α -particles and the β -electrons do really pass through *empty* atoms—*i.e.*, systems with wide inter-spaces—is also proved by the passage of electrons through solids (glass, aluminium) ; if the atoms in these bodies are contiguous, like piles of grenades, or the pebbles in a pile of stones, how can it be explained that external bodies can pass through the inter-spaces and in any direction ? If, however, the structure of the atom itself is open, and it is composed of impenetrable parts which are small in comparison with the spaces, the matter becomes clear at once.

The sharp *bends* or *hooks* which can be seen in the trajectories of the α -particles photographed by Wilson's method, *hooks* which sometimes indicate deviations of 150° , form a certain proof that the nucleus of the atom is highly charged with positive electricity, and that the negative α -electrons—which are undoubtedly present since they appear in many different forms—are in the outer part of the system ; their number is such as to make the atom electrically neutral.

Experiment, then, completely destroys the conception of an atom which occupies a given volume and which is impenetrable ; one atom may pass through another if it possesses sufficient kinetic energy ; in the movements due to thermal agitation, the kinetic energy is insufficient to bring about such an effect ; these are the conditions which correspond to the elastic collision dealt with in the kinetics of gases. As we shall see, the dimensions of the impenetrable part—the nucleus of the atom—do not exceed the ten-thousandth part of the total diameter of the atom.

In conclusion, if the very high velocity and the relatively large mass of the α -particles be considered, the fact that they are deflected or "scattered" in passing through thicknesses of

solid or gaseous bodies, makes it clear that the field of force in action must be one of extremely high intensity.

For this reason Rutherford was led to imagine that the positive charge is concentrated at the centre of the atom in a very small space, while the electrons are distributed around this positive nucleus in a relatively large space which corresponds to the atomic volume. It is clear that these electrons cannot be stationary, because the nucleus attracts them and they would inevitably fall into it; if they are in motion, the whole atom

becomes a solar system in miniature in which the sun is represented by the positive nucleus, while the planets are the electrons revolving around it.

In order that an α -particle may undergo a large deviation, *e.g.*, 150° as shown in Wilson's photographs, it must happen that it passes very close to the nucleus A where the field is intense and where, on the other hand, the action of the external electrons is negligible; the repulsive force, which acts

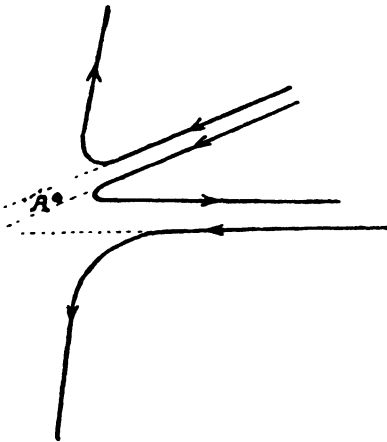

FIG. 105.

inversely as the square of the distance, changes the trajectory from a straight line to a *hyperbola*, and if, as is extremely improbable, the collision were really central, the α -particle would be reflected after having reached a certain distance from the nucleus. Fig. 105 shows a diagram of trajectories with different angles of scattering.

If we observe a continuous stream of α -particles, in the form of a narrow pencil, striking a very thin sheet of gold 2×10^{-5} cm. thick and passing through it, each of these particles will be strongly deflected, and the amount of the scattering can be observed by means of a fluorescent screen of zinc sulphide which is struck by the particles (Fig. 106); it is obvious that the large deflections are due to the action of a single nucleus which contains

a point charge of unknown value $Z.e$; it is written in this form since, as the reader knows, e is the unit charge, the atom of electricity.

How can this nuclear charge $Z.e$ be determined from the number of particles, out of every million, which are scattered through a certain measured angle? We shall see in the next section.

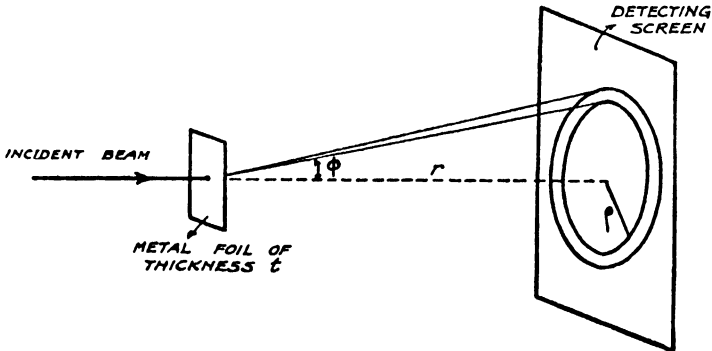

FIG. 106.

Rutherford's Theory of the Scattering of α -Particles in passing through Solids

Let us imagine an atom in which the nucleus carries the charge $Z.e$, and which contains Z electrons disposed about this nucleus within the atomic volume and circulating in paths such that they are in dynamic equilibrium like a solar system; the whole is electrically neutral.

We have already seen that the radius of the electron is very much smaller than that of the atom; if the mass is electromagnetic in origin, we are led to think that the nucleus, in which the whole mass of the atom is concentrated, is, in its turn, of dimensions which are much smaller than those of the electron; this solar system, then, is composed of a punctiform nucleus and of masses which rotate about it at distances which are large compared with the size of this nucleus. Under these conditions, then, the scattering of the α -particles is to be ascribed to the influence of the nucleus alone, the effect of the external electrons being negligible, as has been said already; it can be supposed,

without any appreciable error, that the central charge is the only one which produces any effect.

Let us, then, consider an α -particle moving towards the nucleus of an atom, and let M denote its mass and V its velocity; we know that it carries a charge equal to $2e$. There is a charge Ze concentrated in the nucleus.

The particle will stop at a distance l so that the potential

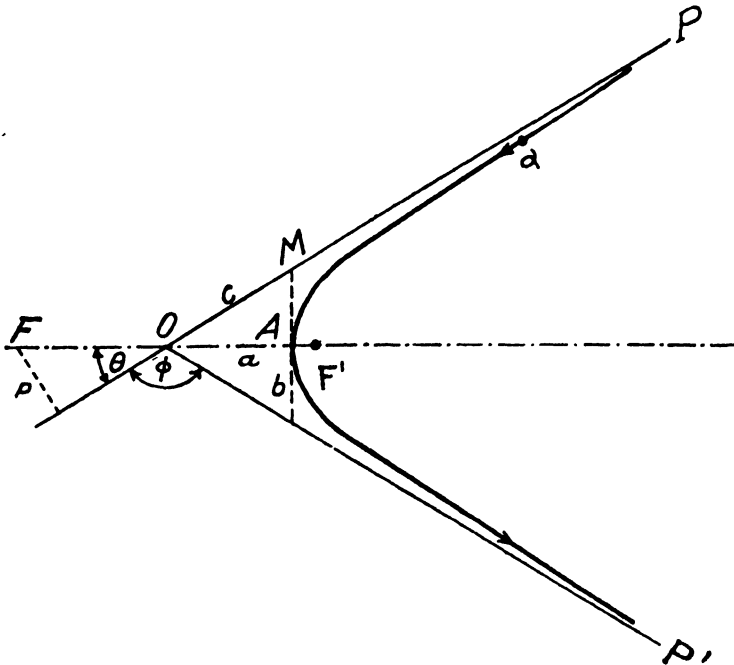

FIG. 107.

energy * $2e(Ze/l)$ is equal to the kinetic energy of the particle, viz., $\frac{1}{2} MV^2$,

$$i.e., \frac{1}{2} MV^2 = 2Ze^2/l$$

whence †

$$l = 4Ze^2/MV^2 \quad (1)$$

* It will be remembered that the potential energy of two electric masses M, M' at a distance apart equal to l is MM'/l .

† In the case of gold, for example, l is 3×10^{-12} cm., and for lighter atoms this distance is less since the force of repulsion of the nucleus is less, the charge Ze which it carries being smaller.

We are here faced with the paradox that, although the nucleus, in general, contains dozens of electrons, its diameter is of the same order as that of a

Let us now consider a narrow beam of α -rays which impinges upon and passes through a sheet of metal foil placed normally to the path of the beam.

After traversing the metal, the rays strike a screen of zinc sulphide, so that the scattered particles may be counted and the number reaching a specified part of the screen may thus be found.

The atoms in the metal screen, of thickness t , must be considered as being disposed at random. The probability that Q particles pass an atomic nucleus at a distance p from the centre is Qp^2nt where n is the number of atoms per unit volume, since evidently this probability is proportional to the number of particles in the beam, to the number of atoms contained in unit volume of the metal screen, to the thickness t of this screen, and finally to the square of p ; this follows from the fact that the *area* through which a particle passes varies as p^2 , and for a single atom of radius R it is πR^2 . From this remark it will be seen that the quantity πQp^2nt is not only *proportional* to the number of particles passing through circular areas of radius p , but actually gives this number. Hence if this distance be changed from p to $p + dp$ it follows that, out of the Q particles, the number scattered at the distance p (and therefore through the angle ϕ) varies as

$$2\pi Qpntdp.$$

Since $p = \frac{1}{2} l \cot \frac{1}{2} \phi$ it follows that

the number of particles scattered at angles lying between ϕ and $\phi + d\phi$

$$= \frac{1}{2} \pi Qntl^2 \cot \frac{1}{2} \phi \operatorname{cosec}^2 \frac{1}{2} \phi d\phi.$$

We have now reached the end of this laborious calculation, for it is easy, knowing the distance r at which the zinc sulphide screen is placed, to determine how many scintillations will be visible per unit area in the region situated at an angle ϕ from the central axis (see Fig. 106). The circular annulus thus defined has an area of approximately $2\pi r^2 \sin \phi d\phi$;

this is struck by a number of particles equal to

$$\frac{1}{4} \pi Qntl^2 \cot \frac{1}{2} \phi \operatorname{cosec}^2 \frac{1}{2} \phi d\phi.$$

The ratio Y between this value and that of the annular area stated above gives at once the number of particles per unit area, *i.e.*, the *scintillations which may be observed*.

Remembering that $l = 4Ze^2/MV^2$, the value of the ratio Y is found to be

$$Y = \frac{QntZ^2e^4}{r^2M^2V^4 \sin^4 \frac{1}{2} \phi} \cdot \cdot \cdot \cdot \quad (6)$$

This gives the number of scintillations as a function of known quantities and is a formula of the greatest importance; by it means the nuclear charge may be deduced from the scintillations observed on the zinc sulphide screen.

Very delicate experiments on gold and silver foils were carried out by Geiger and Marsden in 1913* to verify this law; they counted the particles reaching a square millimetre of the screen.

The first step was to prove—and this was not difficult—that Y/t was constant, *i.e.*, that doubling the thickness of the diffusing layer doubled the number of scintillations per unit area of the screen. Next it was necessary to show that YV^4 was constant, *i.e.*, that halving the velocity of the α -particles by causing them to pass through appropriate screens, caused the number of scintillations on a given area of the screen to increase sixteen-fold. Further, the increase of the value of $Y \sin^4 \frac{1}{2} \phi$ had to be proved constant for various values of ϕ .

Geiger and Marsden's Measurements—Chadwick's Work at Cambridge

All the facts just stated were exactly verified within the limits of experimental error which, it is true, were rather large on account of the difficulties involved in such delicate work.

If equation (6) represents completely the relation between the various quantities involved in the problem, it also provides the means for calculating the nuclear charge Ze , if it is possible to

* H. Geiger and E. Marsden, *Phil. Mag.*, 25, p. 604, 1913.

count the total number of particles, Q , reaching the diffusing screen as well as the number Y reaching a square millimetre in some particular position on the zinc sulphide screen ; now the extremely large ratio between these numbers Q and Y makes the determination a particularly delicate one ; for example, out of 3 million particles incident on the metal, only one is counted on the zinc sulphide ; this is the order of magnitude of the ratio in question.

Example of Results obtained with Silver Foil.

Effect of Angle of Scattering.			Effect of the Velocity of the Particle.		
ϕ	Y	$Y \sin^2 \frac{1}{2} \phi$	V^{-4}	Y	YV^4
105 deg.	47.3	18.7	1.0	24.7	25
60 "	320	20	1.50	33.4	22
45 "	989	20.2	2.84	81	28
30 "	5260	23.6	4.32	101	23

N.B. The figures given for $1/V^4$ are relative values. Actually V is of the order of 20,000 km. per second.

Let us put the following values into equation (6) :—

velocity of α -particles from radium C :	$V = 20,000$ km/sec.
distance of screen :	$r = 1$ cm.
thickness of gold foil :	$t = 2 \times 10^{-3}$ cm.
$\sin \phi$ when $\phi = 45^\circ$:	$\sin \phi = 0.7$
charge of the electron :	$e = 4.77 \times 10^{-10}$ e.s.u.

It is easy to show that for charges Ze of the order of $100e$, the dispersion obtained is in the neighbourhood of one particle in 3 million on a square millimetre of screen.

These measurements were made by Geiger and Marsden, as has been said ; for gold they found that the nuclear charge was about half the atomic weight (197). Other accurate and very delicate measurements of the same kind were made on silver and on aluminium, and the same conclusion was reached in these

cases as for gold. The accurate determination of the nuclear charge was repeated in 1920 by Chadwick ; * the values found for copper, silver and platinum were respectively :

29·3 46·3 77·4

while the positions of these elements in the periodic system are :

29	47	78
copper	silver	platinum.

Other experiments of Geiger and Marsden on the scattering of the α -rays by sheets of platinum, tin and copper led to the same result, *i.e.*, that the nuclear charge is very close to one-half of the atomic weight ; it is clear, however, that it cannot be exactly one-half because the atomic weight is often fractional ; there is, however, another number close to the atomic weight, and this is the atomic number, the number which not only represents—as we have seen—the position of an element in the periodic table, but must undoubtedly have a fundamental significance connected with Moseley's discovery (p. 229).

The work of Geiger and Marsden, and other experiments of Rutherford on the passage of α -particles through gases inevitably led to the conclusion that the atomic number represented the nuclear charge. In 1913, Van den Broeck † had already proposed this hypothesis on other grounds, and Laue, too, in his study of the diffraction produced by the atoms in crystal structures, had been led to the same idea because the scattering power of an atom depended on the number of charges it contained, and this corresponded exactly with the atomic number. There were also other facts in confirmation of this conclusion.

The *displacement* law of radioactivity states that the emission, *i.e.*, the removal, of a β -particle (which is negative) moves the element resulting from the transformation one place forward, and this corresponds to the fact that the two quantities *charge* and *atomic number* increase by one unit ; the emission of an α -particle, on the other hand, causes the element, after disintegration, to move two columns back with respect to its parent element, and

* J. Chadwick, *Phil. Mag.*, 40, p. 734, 1920.

† A. van den Broeck, *Phys. Zeits.*, 14, p. 32, 1913.

the expulsion of the α -particle from the atom entails a loss of two units in the charge ; these particles are emitted from the nucleus.

There is thus no doubt that the charge of the positive nucleus is given by the atomic number. Since, moreover, the atom is, as a whole, electrically neutral, the number of the external negative electrons neutralises the charges in the positive nucleus ; there is only one in hydrogen, in helium there are two, in lithium three, in calcium twenty, in uranium ninety-two.

* Other Estimates of the number of External Electrons in the Atom

J. J. Thomson in 1906 had reached the same result, *i.e.*, he had estimated the number of electrons in an atom and had arrived at the conclusion that this number was approximately equal to half the atomic weight ; his estimates were derived from arguments based on classical electrodynamics, as we shall now briefly describe.*

When X-rays impinge on light atoms, *i.e.*, those with atomic weights not greater than that of sulphur, the scattered radiation is of the same degree of hardness as the incident radiation, and its intensity is roughly proportional to the mass of the diffusing atom, assuming that equal numbers of atoms are involved in the experiment ; for instance, in the case of gases, the intensity of the scattered radiation is proportional to the density and is independent of the nature of the gas. Because of the very short wave-length of the X-rays, the scattering, instead of being brought about by the atoms, is caused by the electrons outside the nucleus as they vibrate freely under the influence of the variable electric force in the wave-front of the primary beam ; these electrons thus become centres of emission of the electromagnetic radiation which appears in the form of the scattered rays.

Let us now follow J. J. Thomson and calculate the intensity of the scattering, *i.e.*, the ratio s between the secondary and the primary energies. The electromagnetic theory gives, for macroscopic systems, a method of calculating the energy E

* J. J. Thomson, *Phil. Mag.*, 11, p. 769, 1906.

which is radiated in unit time by an electric charge e subject to an acceleration a (see p. 43).

$$E = \frac{2}{3} (e^2/c^3) a^2.$$

Let us denote by Z the number of electrons outside the nucleus of an atom and consider a cubic centimetre containing n atoms of radiating matter, the atomic weight of which is P . Since there are nZ electrons vibrating freely under the influence of the electric force F and the acceleration a is equal to $-Fe/m$, the total energy radiated diffusely per cubic centimetre will be

$$\text{Scattered energy} = \frac{2}{3} \frac{e^4}{m^2 c^3} F^2 nZ.$$

But the energy falling on unit area of the radiator is $2(c/8\pi)F^2$ (p. 44), and this multiplied by s is equal to the quantity scattered, so that we have :

$$\frac{c}{4\pi} F^2 \cdot s = \frac{2}{3} \frac{e^4}{m^2 c^3} F^2 nZ$$

and this gives :

$$s = \frac{8\pi}{3} \cdot \frac{e^4}{m^2 c^4} nZ.$$

Now if ρ be the density of the material and m_H the mass of the atom of hydrogen, $\rho = m_H \cdot n \cdot P$ where $P = \text{atomic wt.}$, so that the above equation becomes :

$$\frac{s}{\rho} = \frac{8\pi}{3} \cdot \frac{e^4}{m^2 c^4} \cdot \frac{Z}{P m_H} = 0.40 \frac{Z}{P}$$

putting in the known values of e , m , c and m_H . Barkla (1904) measured the value of the ratio s/ρ for various substances by comparing the intensity of the beam scattered at various angles with the intensity of the primary beam ; for light bodies (air, carbon, aluminium) he found $s/\rho = 0.2$ in every case, and this gave $Z/P = 0.5$. This is how it has been shown that the number of the external electrons is half the atomic weight.

It is to be noted that with the rather *soft* X-rays used, there was no noticeable emission of the characteristic radiation.

Thomson's formula :

$$s = \frac{\text{scattered energy}}{\text{incident energy}} = \frac{8\pi}{3} \cdot \frac{e^4}{m^2c^4} \cdot nZ$$

indicates that the ratio s is independent of the frequency of the X-rays ; this, however, is not confirmed by experiment in the case of very low or very high frequencies.

In the latter case, not only is the scattering coefficient less, but in addition to the ordinary simple scattering there is radiation present which has a frequency rather less than that of the primary beam ; this is the Compton effect, which we shall deal with in Vol. II, Chap. VI.

In the case of very low frequencies the scattering coefficient is greater because the atoms themselves act as centres of diffusion ; the amplitude of vibration becomes Z times as great, while the number of centres is reduced in the ratio 1 to Z , but the energy scattered varies as the square of the amplitude, and this explains the experimental result.

The classical treatment therefore fails in this problem of the interaction between matter and radiation.

The Size of the Nucleus

We know already that the dimensions of the atom are of the order of 2×10^{-8} cm. ; for hydrogen the molecular diameter is 2.75×10^{-8} ; for helium, 2.18×10^{-8} cm. ; and since helium and the other rare gases are monatomic, this is the true atomic size.

The electron, which is extremely small, has a mass which is only 1/1840 of the mass of the hydrogen atom ; for any atom, even in the case of the heaviest element such as lead, bismuth or uranium, the whole system of external electrons together accounts for only a small portion of the total mass which therefore is almost entirely concentrated in the nucleus.

Geiger and Marsden's experiment showed that the law of scattering of the α -particles expressed by equation (6) was universally true, even for the largest deflections, viz., 150° . It may be concluded, therefore, that these particles which are very

much deflected, describe hyperbolic paths as they approach very closely to the nucleus, and that throughout their path—even when at their closest to the nucleus—they are subjected to a repulsion which varies inversely as the square of their distance away; this means that they *do not touch the nucleus*.

It is, then, possible to calculate, by means of equation (5), a value which has already been stated, viz., the least distance from the centre of the nucleus which can be attained by these greatly deflected particles.

Actually

$$\overline{FA} = \frac{2Ze^2}{MV^2} (1 + \sec \theta)$$

where M is the mass of the α -particle, which is known to be 6.6×10^{-24} gms., V is the velocity, which in the case of radium C is 2.06×10^9 cm./sec., Ze is the nuclear charge, which in the case of gold is $79e$.

When $\theta = 30^\circ$, $\sec \theta = 2$.

On substituting in equation (5) the values just given, it will be found that $\overline{FA} = 4 \times 10^{-12}$ cm. It may therefore be concluded that, at least down to distances of this order, Coulomb's law of the inverse square still applies.

The radius of the atomic nucleus of gold is thus certainly less than 4×10^{-12} cm., and is therefore at most one ten-thousandth part of the radius of the atom.

There is, however, another line of reasoning, based on radio-activity, which gives a similar value for the dimensions of the nucleus of a heavy atom.

The α -particle, as it leaves the nucleus, acquires its final velocity as it passes through the surrounding field of repulsive force; in order to obtain a lower limit, let us consider the α -particle expelled from uranium, as this is the slowest of all the α -particles shot off by the various nuclei; if the kinetic energy acquired by the particle be equated to the potential of the electrostatic field, it will be found that the radius of the uranium nucleus is of the order of 6×10^{-12} cm.

Let us now come to the hydrogen nucleus. Rutherford, as we shall see presently, has carried out some marvellous experiments by means of which he has studied the effect of the collisions of α -particles emitted by radium and shot into a gas, *e.g.*, hydrogen, and has been able to show that this results in propelling the hydrogen nuclei forward so that they produce scintillations on a fluorescent screen of zinc sulphide. The velocity acquired by the nucleus clearly depends on its mass and on the minimum distance of approach of the α -particle, which has acted on the nucleus and repelled it; now the velocity acquired by the nucleus can be found from the distance which it can travel in air as compared with the distance which an α -particle of known velocity can travel in air under the same conditions.

It was found by Rutherford * that, for direct collisions, the hydrogen nucleus acquired a velocity 1.6 times as great as that of the α -particle which set it in motion; from a knowledge of the electric charges involved it was found that the centres repelling each other must have approached to within a distance of 1.7×10^{-13} cm. and this, therefore, is the sum of the radii. Now the atom of helium forming the α -particle contains two electrons, and hence its radius must be at least as great as that of an electron (1.8×10^{-13} cm.). It is to be concluded that the *radius of the positive nucleus must be so small as to be negligible compared with the radius of an electron.*

We are here again faced with a problem which can be solved by assuming that every mass is electromagnetic in origin; actually the charges of the electron and of the hydrogen nucleus are equal, and yet the mass of the nucleus is 1,840 times as great as that of the electron.

Since the mass m is connected with the radius and with the charge (for spherical particles carrying surface charges) by the relation $m = 2e^2/3a$ it will at once be seen that the radius of the electron is 1,840 times as great as that of the hydrogen nucleus; the latter will thus be of the order of 10^{-16} cm.

These are dimensions which the human mind cannot imagine.

* E. Rutherford, *Phil. Mag.*, 37, pp. 537, 562, 571 and 581, 1919. C. G. Darwin, *Phil. Mag.*, 41, p. 486, 1921.

The nucleus of hydrogen—which has been given the name *proton*—is the smallest particle which enters into the constitution of matter; its mass is practically equal, as has been said already, to the mass of the atom which it forms.

The Nucleus and the surrounding Electrons

The nuclear charge does not simply represent the number of elementary positive charges contained within the nucleus; the emission of β -rays in radioactive transformations is proof of demonstration that negative electrons are also included in the composition of the nucleus and, further, it will be understood immediately—in spite of the fact that we know very little of the nuclear structure—that some electrons are necessary in order to attain stability.

It is easy to calculate the number of charges contained in the nucleus of any given atom.

The rounded-up atomic weight, P , is equal to the number of protons in the nucleus and so represents its positive charge; the atomic number Z , on the other hand, represents the number of external electrons; it can be seen at once that since the atom is an electrically neutral system, the nucleus contains, besides the protons, a number of electrons sufficient to reduce its apparent charge from P to Z .

For example, potassium has an atomic weight (39·10) and an atomic number (19). This means that there are 20 electrons in the nucleus ($39 - 20 = 19$). On going through the table of elements, it will be seen that the ratio Z/P is approximately 2 for the elements of low atomic weight, *i.e.*, those which occur early in the periodic system:

$$\begin{array}{lll} \text{nitrogen} = 14/7 & \text{oxygen} = 16/8 & \text{sodium} = 23/11 \\ \text{silicon} = 28\cdot06/14 & \text{chlorine} = 35\cdot46/17. & \end{array}$$

This ratio increases continuously as the atomic weight increases, *e.g.*, chromium 52/24, zinc 65·38/30, tin 118·7/50, barium 137·37/56, tungsten 184·4/74, uranium 238·2/92.

It will be clear that this increase expresses the fact that a continually larger number of external electrons is necessary in

order to give stability. It follows that all the physical and chemical properties of an element are determined by the nuclear charge.

Finally it will be seen that the atomic number has a fundamental significance in that it defines the nuclear charge.

The existence of *isobares* and of *isotopes* is completely explained by Rutherford's conception of the atom; two atoms may differ as regards the number of external and nuclear electrons they contain, although they have the same weight (*i.e.*, are *isobares*) owing to the fact that they contain equal numbers of protons. This is the case, for instance, with radium B, radium C and radium C'. These three bodies have each the atomic weight 214 although their atomic numbers are respectively 82, 83 and 84.

The existence of isotopes is explained equally clearly, since it is easy to imagine two atoms with different atomic weights but with equal numbers of external electrons, the factor upon which depend, as has been said, the chemical properties of the elements. Such a pair of elements will therefore be identical to all intents and purposes. For example, if chlorine has the two isotopes 35 and 37, and if its atomic number is 17, the first of the two isotopes will have 35 protons in the nucleus and 18 electrons, while the second isotope will have a nucleus consisting of 37 protons and 20 electrons; it is clear, however, that the identity of the two isotopes must not be extended to include properties which depend on the constitution of the nucleus. It will be understood that these twin elements have not the same stability; in fact they are known to differ in this respect, the radioactive elements of a single series being distinguished from one another by their disintegration constants and sometimes also by the nature of the rays emitted.

By means of an electric discharge, or by the action of X-rays or by ultra-violet light, it is possible to cause one of the external electrons to leave an atom; this does not alter the atom fundamentally; the emission of an electron from the nucleus, however, corresponds to a real transformation; the nucleus readjusts itself, but a new element is formed; the phenomenon is essentially different, and the amount of energy liberated in

such transformations—*i.e.*, the radioactive transformations—is evidence of this.

It is the nucleus which gives the atom its individuality ; we know that the α -particle, an atom shot off with two electrons missing, easily picks up free electrons, attaches them to itself and becomes a helium atom.

There is a vast gap between a radioactive change—which results in the emission of β -rays from the nucleus—and the emission of electrons under the influence of an external agent such as light or heat ; in spite of the apparent similarity, the former phenomenon is fundamental while the latter is, in a sense, secondary.

The various Atoms contain α -Particles

The emission of α -particles by radioactive substances shows that they, like the β -particles, are a constituent of matter, and perhaps exist in the nucleus before emission ; moreover, it is not only in the radioactive substances that they seem to occur as constituent parts, because it has already been shown that in the upper part of the periodic table the atomic weights in the even columns are frequently multiples of 4 (oxygen 16, magnesium 24, sulphur 32, calcium 40, chromium 52), while in the odd columns the atomic weights are most frequently represented by the formula $4n + 3$ where n is an integer (lithium 7, boron 11, fluorine 19, potassium 39), and sometimes by $4n + 2$.

Speaking more generally, it may be said that a difference of 4 between the atomic weights is particularly frequent.

It is difficult to ascribe these facts to pure chance, and since 4 is just the weight of the α -particle, it would seem that this must really behave as a unit in the atomic structure.

It has been noticed that there is a striking difference between these two series of elements (those with even numbers and those with odd numbers) as regards the plentifulness with which they occur on the earth, and this difference has been the subject of scientific study.*

* This difference is one of the so-called Rules of Harkins. See *Proc. Nat. Acad. of Sciences*, Washington, 1, p. 276, 1915, and *Zeits. f. Physik*, 50, p. 97, 1928.

The even-numbered elements together form about 90 per cent. of the earth's crust; the rare-earth metals, on the other hand, and the radioactive elements which, like them, only exist in very small quantities, belong to the odd-numbered series, and so do the elements, which have not yet been discovered. It would seem, therefore, that the great stability of the even-numbered elements (oxygen 16, silicon 28, calcium 40, sulphur 32) must be attributed to the simplicity of their nuclei; they are nothing but aggregates of helium atoms. In the formation of a helium atom by the combination of 4 atoms of hydrogen, the atomic weight of which is 1.008, there is, as we know, a loss of mass equal to $0.008 \times 4 = 32$ thousandths, corresponding to an energy of $0.032 \times c^2$ where c is the velocity of light.

In the formation of a gramme-atom of helium, then, there would be the liberation of 6,000 million great calories. The formation of any atom may be thought of as taking place in two stages: the first consists of the formation of atoms of helium, and in the second stage these join together to form a nucleus of the type $4n$ or attach to themselves a number of protons so as to form nuclei of the types $(4n + \text{H}_2)$ or $(4n + \text{H}_3)$.

Further, if it is in the first of these two stages that such large quantities of energy are liberated, far in excess of the amount set free in the second stage of the synthesis, it will be easily seen why the nuclei—and therefore also the atoms—of all the elements show a loss of mass which is approximately a constant proportion of the whole, viz., eight thousandths.

In radioactive transformations, the loss of mass is generally not very different from this same value, but the emission of α -particles is of less importance as regards loss of energy, and therefore also as regards the corresponding reduction of mass.

For instance, the α -particle of radium is emitted with a velocity of 14,700 km./sec. This gives:

$$\begin{aligned} \text{kinetic energy } \Delta E &= \frac{1}{2} mV^2 = \frac{1}{2} m (V/c)^2 c^2 \\ &= \frac{1}{2} \cdot 4 \cdot (V/c)^2 c^2 = 0.0047 c^2, \end{aligned}$$

and since the loss of mass Δm is given by $\Delta E/c^2$ it will be seen that for every gramme of element transformed, 4.7 mg. is lost,

while in the synthesis of helium the loss is 32 mg. per gramme. The loss of mass by the emission of an α -particle is therefore only one-seventh as much.

From all the foregoing it will be clear that Rutherford's atom accounts quite satisfactorily for the properties possessed by radioactive substances, for the phenomena inherent in X-rays, for the existence of isotopes and isobares, and for the scattering of α -particles in passing through matter; Rutherford's model gives us a picture of the profound difference which exists between chemical changes and the transmutation of the elements, and it enables us to realise the fundamental part played by the atomic number, or what is the same thing, the nuclear charge, in all the properties of the different atoms. The reader is put in a position to understand the real basis of Mendeleieff's system, and all the material so far presented is brought together in one harmonious picture by this conception due to Rutherford.

A great step forward has thus been taken as regards our knowledge of the atomic structure; it is now established that the atom contains a nucleus of extraordinarily small dimensions in which practically the whole of the mass is concentrated, that the charge of the nucleus is $Z \times e$ where Z is the position number of the element and e the charge of the electron; it is practically certain that the hydrogen nucleus is the unit of mass and, at the same time, the long-sought positive electron; the nucleus is seen to be surrounded with electrons situated at large distances from the centre in separate rings or zones and equal in number to the so-called atomic number.

On the other hand, the arrangement and the motions of these electrons are not dealt with by Rutherford's theory, and there is therefore still a further step to be taken. To Bohr, the scientist of Copenhagen whose theory won for him the Nobel prize, is due the credit of taking this further step, although his original theory has been modified by subsequent research; he has opened up to physics new vistas, and his ideas now form the basis of a considerable part of physical science; the picture of the atom which he proposed is known as "Bohr's atom," and we shall consider it in detail in Vol. II, Chap. II. It is true that Bohr's ideas

have had to be revised during the last few years, but a great part of them remains; later theories are modified, and die; much of Bohr's theory still survives.

The Artificial Disintegration of the Elements (1919-1923)

Rutherford's model, in which the atom is an aggregation of charges surrounded with swiftly moving electrons, immediately suggested the possibility of bringing about chemical transmutation, such as the production of gold; one method was to cause the expulsion of an α -particle and a β -particle from an atom of mercury.

The discovery of the cathode rays and, still more, that of the radiation of extremely high energy content emitted from radioactive substances which shot off particles having a speed of 20,000 km./sec., naturally revived the hope that by such powerful means it would be possible to disintegrate the atoms of the elements.

The well-known English chemist, William Ramsay, had already in 1908 tried to produce such transmutations artificially, but we cannot pause to describe his experiments which are, in fact, well known, and the results of which have since been rendered doubtful by the criticisms of scientists who have considered them to be illusory.

Experimental chemistry, after a century of work, had shown that it was impossible to break down the atoms of the elements by using ordinary physical or chemical methods. This idea has been somewhat modified during the last twenty years or more as a result of the rapid increase in our knowledge of the constitution of the atomic nucleus; the electrons occupy but do not fill a space having a diameter of 10^{-8} cm.

In this representation of the atom, the ordinary physical and chemical properties (mass excepted) depend entirely, as we have seen, on the nuclear charge, since it is this that determines the number and disposition of the external electrons on which these properties depend.

In order to effect a *permanent* change, it would seem to be necessary to break down the nucleus itself; when a unit of the

nuclear charge is removed, the nucleus undergoes a profound alteration and the atom suffers a transmutation.

The discovery of the instability of the radioactive elements was the first blow to the ingrained idea of the immutability of the elements; radioactivity—by virtue of which an atom, in disintegrating, forms two different elements—is entirely confined to the heavier elements, and it must be recognised that the fact that the number and the velocity of emission of the α - and β -particles shot off during the change are not affected by the most powerful chemical or physical agents available to man is a proof that we are here dealing with a property which is bound up with the instability of the complex nuclei of uranium and thorium, and the elements which are formed from them.

Now radioactivity has not only provided the key to the problem of the structure of the elements, but thanks to the very fast α - and β -particles, it has supplied a means for examining the internal constitution of the atom; by bombarding various bodies—elementary or compound—with α -particles, Rutherford has, in fact, succeeded in splitting up atoms with the consequent production of protons, *i.e.*, hydrogen.

Before describing these wonderful experiments we may remark that what is known to-day concerning the constitution of the atom enables us to understand better than formerly why it is so difficult to decompose it; the resistance it offers to the most powerful agents applied to disintegrate it is not only due to the stability of the nucleus, but also to its extreme smallness, in virtue of which it is rendered almost immune from attack; actually, as we saw when considering the experiments on the deflection of α -particles in passing through matter, the diameter of the nucleus of the heavy atoms is of order of 4×10^{-12} cm., *i.e.*, 1/5000 of the diameter of the atom; the size of the nucleus of the lighter atoms must undoubtedly be still less.

If it were not for this, the available α -particles, representing as they do a highly concentrated form of energy, would be able to decompose the elements in more readily appreciable quantities.

These α -particles travel 20,000 times as fast as a rifle bullet and contain, mass for mass, 400 million times as much kinetic

energy ; nevertheless, such a particle, in passing among thousands of atoms, has only a very small chance of striking one ; further, when a collision takes place, its violence is reduced by the repulsive action of the electric field. As regards this latter consideration it will be understood that there is more chance of a successful disintegration in the case of a light atom, since the force of repulsion is much smaller in this case.

By subjecting matter to bombardment by the fastest α -particles emitted from radium C, Rutherford succeeded for the first time in observing an undoubted decomposition of a chemical element by artificial means.

We must first of all say something about the collisions of α -particles with the hydrogen nucleus. We referred to this some pages back when dealing with the dimensions of the nuclei.

When an α -particle, shot into hydrogen gas, meets a hydrogen nucleus, it must impart to this nucleus a velocity which is 1.6 times as great as its own, as will be clear from the following simple calculation. If an elastic sphere of mass m_1 having a velocity v_1 meets another perfectly elastic sphere of mass m_2 and velocity v_2 , the velocities of the two spheres after the collision are given by the simple formula applicable to the theory of collisions between elastic spheres. Thus

$$V_1 = \frac{(m_1 - m_2)v_1 + 2 m_2 v_2}{m_1 + m_2}$$

$$V_2 = \frac{(m_2 - m_1)v_2 + 2 m_1 v_1}{m_1 + m_2}$$

In the case under consideration, the α -particle has a mass m_2 which is equal to $4m_1$, because it is four times as great as the mass of the hydrogen nucleus ; further, the nucleus struck is stationary at the moment of collision, so that $v_1 = 0$. Putting these values in the above expressions we find :

Velocity acquired by the nucleus = $1.6v_2$.

„ of the particle after collision = $0.6v_2$.

The proton, therefore, is impelled with a velocity which is 1.6 times as great as that of the atom of helium which strikes it.

Now if it be assumed that the range of the hydrogen nucleus—

in relation to its initial velocity—follows the same law as that found in the case of α -particles (range increases as the cube of the velocity), it is to be expected that the nuclei which are set in motion will not be brought to rest until they have traversed a path which is four times as long as that of the α -particles themselves (since 4 is the cube of 1.6). This prediction has been verified.*

We must mention here that, according to current practice, the penetrating powers of the particles are expressed by stating their range in air at atmospheric pressure, although in the experiments the *absorbing material*, *i.e.*, the matter in which the particles move, is generally some other gas or even a sheet of metal or of mica; since the absorbing powers of such materials relative to air are known, everything is expressed in centimetres of air; for instance, radium C emits α -particles or, if it be preferred, corpuscular radiation, having a range of 7 cm. in air, and after traversing this distance the particles are stopped.

Rutherford's Experiment on Artificial Atomic Disintegration

The disintegration produced by α -particles was detected in the following way. The apparatus used by Rutherford for his earlier experiments was quite simple (see Fig. 108); it consisted of a small brass box ($18 \times 6 \times 2$ cm.) provided with taps so that the gas under examination could be caused to pass through it; at one end of the tube was a hole covered with a thin sheet of silver, S, sufficient in itself to stop the α -particles and acting as a layer of air 4 to 6 cm. thick; at the other end was a sheet of glass, C.

The detecting screen of zinc sulphide was fixed outside at a distance of 1.5 mm. from S, thus leaving a space in which mica absorbing screens could be inserted. The radioactive source was placed inside the tube on a support the distance of which from the zinc sulphide screen could be varied. In order to reduce the

* Marsden in 1914 projected α -particles from radium C into hydrogen gas in which they had a range of 24 cm. He observed scintillations produced by *H rays* on a screen at a distance of 80 cm. The conclusion he drew at that time was that these scintillations were not due to X-rays, but to other rays produced by them.

luminosity due to the β -rays also emitted from the source (radium C), the whole apparatus was placed in a strong magnetic field which deflected the β -electrons to the side.

Let us suppose that the absorbing materials inserted between the source and the screen correspond to 20 cm. of air; when an atmosphere of hydrogen is admitted to the tube, numerous scintillations are observed even when the screen is removed to a distance equal to as much as 29 cm. of air. A study of the deflections which these penetrating particles undergo in a magnetic

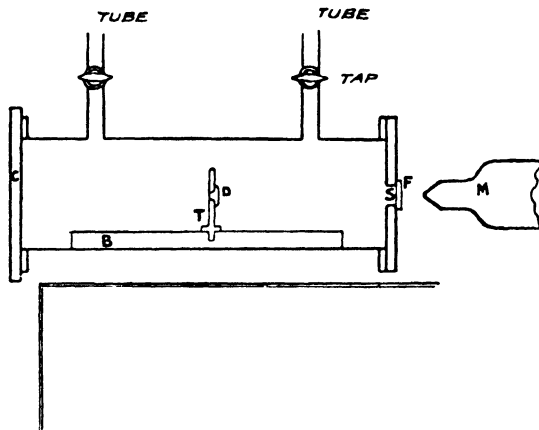

FIG. 108.—M, Microscope. C, Glass plate. S, Thin silver plate. F, Zinc sulphide screen. B, Rotating stand for moving the support T. D, Radio-active substance emitting α particles.

field (producing, as they do, brief flashes of light on the zinc sulphide screen) shows that they carry a unit charge of positive electricity, and that their mass is equal to that of the hydrogen atom; they are therefore atomic nuclei of this element. Particles of identically the same kind are emitted when the rays pass through a film of a compound containing hydrogen (*e.g.*, paraffin), and it is clear that the fact that the hydrogen is in chemical combination has no appreciable effect; Rutherford anticipated this result, because the energy necessary to set the hydrogen nuclei in rapid motion is enormous when compared with the small amounts of energy involved in chemical reactions. The important conclusion which he drew was that, using particles with a range of 7 cm., no proton emitted from hydrogen, whether

free or in chemical combination, could be detected if the absorption exceeded 30 cm. of air.

When oxygen was introduced into the apparatus no scintillations were visible with an absorption of 30 cm. of air.

When air was substituted for oxygen, Rutherford observed the unexpected and extraordinary phenomenon of the appearance of a vast number of scintillations, and by adding sheets of mica he found that these disappeared only when, by adding screens, he raised the absorption to 40 cm. of air ; thus these very penetrating

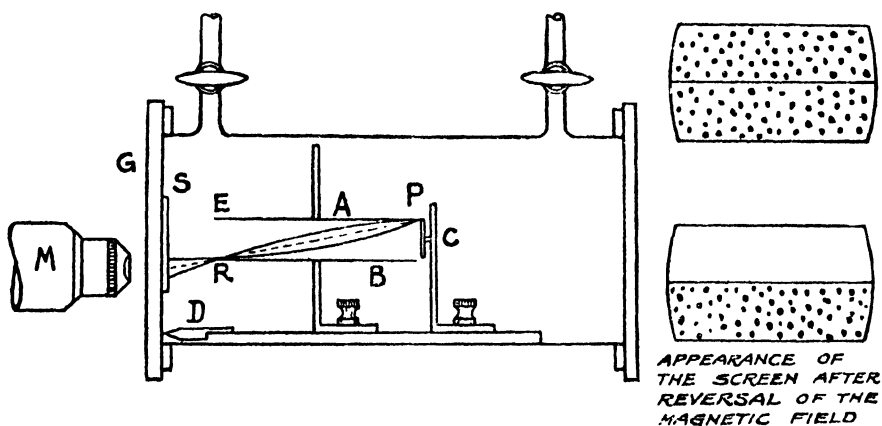

FIG. 109.—Rutherford's apparatus for detecting long-range protons.

particles emitted from the nitrogen had a much longer range than the hydrogen atoms themselves when bombarded with the same α -rays ; Rutherford's measurements showed that the ratio of the charge to the mass, deduced from deflections in a magnetic field, was exactly that appropriate to an atom of hydrogen carrying one positive charge ; * these particles, therefore, were

* That the long-range particles obtained from nitrogen were really hydrogen nuclei was proved by measuring their deflection in a magnetic field. The apparatus used by Rutherford for this purpose is shown in Fig. 109.

The disc attached to the support C is the source of α -particles ; A and B are two parallel plates about 7 cm. long, 1.5 cm. wide and 8 mm. apart ; S is the zinc sulphide screen ; M is the microscope used for observing the scintillations. Absorbing screens inserted between S and R stop the nitrogen and oxygen atoms which have a range of 9 cm. When the magnetic field is not acting, the boundary between the area within which the scintillations are numerous, and that in which they are only seen occasionally is the trace

hydrogen nuclei detached from nitrogen nuclei. It was impossible, in view of what was known regarding the range of the *neutral* atoms of hydrogen, to attribute these scintillations at long ranges to water-vapour contained in the air used for the experiment, or to any other hydrogen compound. Rutherford and Chadwick then proceeded to examine a large number of elements to see if they produced particles which had a range greater than 32 cm. ; when it was not possible to use the element by itself, they used a compound with an *inactive* element such as oxygen ; this was the case with calcium, for example. A thin sheet of gold was covered with the substance in powder form, so as to form a coherent layer (the absorbing power of which, in centimetres of air, was known), and this was placed in the path of a stream of α -particles from a sample of radium C. These experiments showed that all the elements as far as phosphorus, except helium, neon and argon, yielded hydrogen nuclei ; the protons emitted in the disintegration had a range which rose from 40 cm. in the case of boron, fluorine and sodium, to 65 cm. for phosphorus, and reached 90 cm. in the case of aluminium.

The energy of these rapid particles is thus greater than the energy of the incident α -particles ; from all that has been said above with regard to the range of the protons shot forward in the direction of the collisions to which they are subjected by α -particles entering a hydrogen atmosphere, it is known that the velocity acquired by the H atom is 1.6 times as great as that of

of the line PR produced to cut the screen. The effect of the field is to displace this boundary, and the strength of the field may be so regulated that, by reversing it, the scintillations are at first all below and then all above a horizontal line seen through the microscope, as shown in the figure. It is impossible to interpret this experiment by itself, since the long-range particles are produced at every point in the magnetic field within the range of the α -particles (although mainly close to the source). Rutherford therefore repeated the experiment with a mixture of hydrogen and carbon dioxide so as to obtain the same absorption for the α -particles as in the case of air. Under these conditions the effect of the magnetic field on the scintillations was indistinguishable from the effect when using air. Now since, in the case of the mixture, the long-range particles cannot be anything but hydrogen nuclei, this demonstrated that the scintillations obtained with nitrogen were really due to protons, and the only possible source of these was the nitrogen nucleus.

Preliminary experiments showed that carbon dioxide alone gave no scintillations.

the incident α -particles, and the range in air is 28 cm. ; since, however, the range of a proton resulting from the disintegration of aluminium is 90 cm., it follows that its kinetic energy is 1.4 times that of the incident α -particles. Thus, contrary to all expectation, the decomposition of these elements does not absorb energy, but, on the contrary, it produces energy just like the radioactive transformations.

It is noticeable that the only elements which in these early experiments were disintegrated by α -rays with the production of hydrogen, were the elements belonging to the series having atomic weights $4n + 3$ or $4n + 2$, n being a whole number and 4 the atomic weight of helium. For example :

The atomic weight of boron is $11 = 4 \times 2 + 3$.
 „ „ „ „, nitrogen is $14 = 4 \times 3 + 2$.
 „ „ „ „, sodium is $23 = 4 \times 5 + 3$.
 „ „ „ „, phosphorus is $31 = 4 \times 7 + 3$.

It is therefore natural to suppose that the protons detached from the nucleus are simply those hydrogen atoms which do not form part of a helium particle.

The quantities of matter decomposed by the passage of the α -particles are extremely small ; Rutherford estimated that about 300,000 α -particles were needed to liberate a single proton ; his success in demonstrating the decomposition of the atoms is due to the marvellous sensitivity of his method of observation which enables the individual atoms to be detected.

Rutherford and Chadwick's improvement of their Method

In these experiments the material to be bombarded was placed immediately in front of the source of α -particles and, as has been said, the scintillations were observed on a screen of zinc sulphide placed on the other side of the material ; by interposing absorbing screens equivalent in all to 30 cm. of air, the results were made independent of the presence of hydrogen, whether free or in combination, in any impurity present in the substance being bombarded.

Some light elements were examined with smaller amounts of

absorption, but generally the number of protons due to impurities in the radioactive material and in the material under examination were such as to make the results untrustworthy and, moreover, in these experiments the presence of long-range particles introduced a further complication, since in general they were numerous in comparison with the effect ordinarily observed.

In order to overcome this difficulty, Rutherford and Chadwick devised an improved method by means of which they could observe the disintegration of an element with certainty, even when the protons emitted had a range of less than 30 cm. in air.

The new method is based on the fact that the protons are emitted in all directions about the incident rays, so that if the particles observed are those liberated in directions perpendicular to that of the incident α -particles, these latter create no difficulty. There is no need to take account of the so-called *natural H* particles, since if a compound of hydrogen—such as water, paraffin, etc.—is exposed to a radioactive source, the H particles are all emitted at angles of less than 90° , as will be clear from the mechanical considerations applicable to free or stationary particles; these considerations apply equally to atoms attached to molecules, for the forces linking the atoms together are negligible compared with the energy which is brought into play when the α -particles collide with the nuclei. It is therefore sufficient to insert absorbing screens so as to prevent these natural H particles from reaching the zinc sulphide screen.

The movable support which carries the radioactive source and the material to be bombarded, is placed in an evacuated brass box; the zinc sulphide screen is placed outside the box in front of a hole covered with a sheet of mica equivalent to 7 cm. of air.

This method has the great advantage that protons with ranges of less than 30 cm. can be detected; in the case of ranges less than 7 cm., however, the diffused α -particles may reach the screen and so cause a complication. The presence of natural hydrogen in the material bombarded has no effect, as we have said already, and this may be demonstrated by bombarding paraffin and noticing that no scintillations are produced on the zinc sulphide screen.

As was to be expected, this new method enabled various elements to be disintegrated, viz., neon, magnesium, silicon, sulphur, chlorine, argon and potassium. Iron did not give any reliable results owing to the difficulty of obtaining it perfectly free from other bodies liable to disintegration, e.g., nitrogen, which always gave fictitious results; thus while a piece of electrolytic iron gave no protons with ranges greater than 7 cm. of air, a piece of Swedish iron gave a marked effect which undoubtedly was attributable to nitrogen; in fact, prolonged heating in a vacuum resulted in an almost complete disappearance of this result of apparent disintegration. Rutherford found no effect in the case of nickel, copper, zinc, silver or gold, all of which seemed to resist disintegration.

Whilst these wonderful researches, realising the dreams of the mediæval alchemists, were proceeding at Cambridge during the years 1924–1927, other parallel experiments were being carried out by Kirsch, Schmidt, Pettersson and others, using experimental criteria which space will not permit us to describe.*

The study of disintegration, together with that of the diffusion of α -rays in matter, forms the principal source of our information concerning the structure and properties of the atomic nuclei; we are, however, still very far from possessing a complete knowledge of these matters.

In addition to certain differences of method, there is some diversity of opinion between the laboratories at Cambridge and at Vienna concerning the number of elements that can be disintegrated; thus while Rutherford and Chadwick state that protons are emitted—on bombardment by α -rays having a range of 7 cm.—by the lighter elements of the periodic system up to and including potassium, with the exception of helium, lithium, beryllium, carbon and oxygen, the workers at Vienna assert that they have disintegrated all these latter elements as well, with the single exception of helium, and they add to the list other elements heavier than potassium; sulphur is now universally agreed to be capable of disintegration.

It will be understood at once why it is impossible to break up

* Pettersson and Kirsch, *Atomzertrümmerung*.

the helium nucleus by means of a collision with an α -particle; in fact a very simple calculation is sufficient to show that the energy emitted during the formation of an atom of helium is equal to that of several of the fast α -particles emitted from radium.*

Besides the scintillation method, several others have been used; Blackett (1925) used the well-known condensation method, devised by Wilson, which shows up the paths of the particles in motion, as we shall explain in the next section; in 200,000 photographs giving about 400,000 trajectories of α -particles in moist nitrogen, there appeared traces of the expulsion of 8 protons, and the remarkable fact was noticed that the α -particle remained attached to the nucleus which it bombarded.

A very elegant method is that of Ortner and Stetter (*Phys. Zeits.*, 28, p. 70, 1927) who, by means of telephonic amplifiers with thermionic valves, succeeded in detecting, as distinct blows in a telephonic receiver, the momentary currents produced in an ionisation chamber by single particles; the α -particles were distinguished from the protons by the difference in the intensity of the sound heard in the telephone.

At the congress at Como (September 1927), Rutherford described further progress which has been made in the development of the nuclear theory of the atom, but to describe this here would carry us outside the limits of this book.

Photographs of the Expulsion of Protons obtained by P. M. S. Blackett (1925)

Blackett,† by using the "cloud method," was successful in photographing collisions (between α -particles and an atom of gas) which were followed by the expulsion of a proton; following C. T. R. Wilson's method (see p. 317), the path of the particles

* Since the loss of mass which takes place in the formation of helium is $4 \times 0.0077 = 0.03$, the energy represented by a gramme atom of helium is $0.03 \times 90 \times 10^{20} = 2.6 \times 10^{19}$ ergs = 6,000 million large calories.

Thus, the energy required for the formation of a single α -particle is $2.7 \times 10^{19}/60.6 \times 10^{22} = 4.4 \times 10^{-6}$ ergs. This is about three times as great as that of the fastest α -particle.

† P. M. S. Blackett, "The Ejection of Protons from Nitrogen Nuclei," *Proc. Roy. Soc.*, 107, p. 349, 1925.

was made visible by means of a sudden expansion which caused the water-vapour present in the gas to condense in minute drops on the ions produced by the α -particles in their path. It is clear that in order to determine the angles between the trajectories—that of the incident α -particle, that of the particle after the collision, and that of the expelled proton—a single photograph is not sufficient because of the effect of perspective in altering these angles, unless the plane containing the three trajectories happens to be parallel to the photographic plate; Blackett therefore used a mirror device by means of which he could obtain photographs in two planes at right angles; from these two records the true angles could be found.

Fig. 110 shows a photograph of a collision of an α -particle with oxygen, giving two *views* of the same “fork.” The longer arm of the fork corresponds to the path of the α -particle after the collision, while the shorter arm corresponds to the path of the O nucleus. A determination of the two angles enables the ratio between the two masses to be calculated.

Fig. 111 shows a copy of photographs by Blackett of α -particles in helium. The true angle between the two arms is $89^{\circ} 27'$, and Blackett calculated 0.981 as the ratio between the masses which, as we know, is really unity.

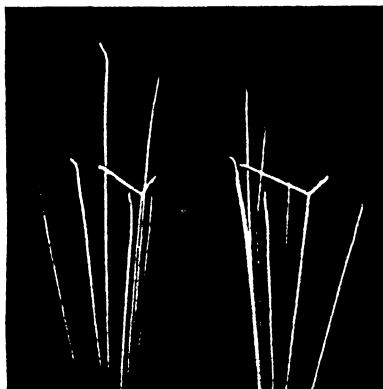
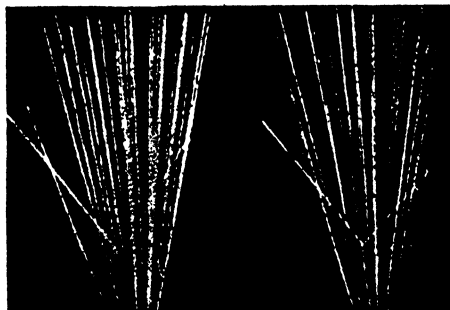

FIG. 110.

FIG. 111.— α -particles in helium.

Rutherford and Chadwick had already shown that out of a million α -particles with a range of 8.6 cm., the expulsion of a proton from nitrogen occurred only about twenty times; Blackett had

therefore to take thousands of photographs in order to be able to examine some forked tracks corresponding to the expulsion of a proton ; the trace of the proton is finer than that due to an α -particle ; the angle which the path of the incident particle makes with the two arms of the fork do not correspond to the case of an elastic collision, but the three are *all in one plane* ; this shows that although the kinetic energy of translation is not conserved in such a collision, owing to the introduction of the nuclear energy, nevertheless the *conservation of momentum* still holds. The velocity of the proton expelled may be calculated by this method, and the value actually obtained is in agreement with that deduced by Rutherford and Chadwick from the ranges of the protons as determined in the scintillation experiments which they described.

BIBLIOGRAPHY

- E. N. DA C. ANDRADE. "The Structure of the Atom" (1927).
 H. WILSON. "Modern Physics" (1928).
 H. PETERSSON and KIRSCH. "Atomzertrümmerung" (1926).
 "Elektronen, Atome, Moleküle," *Handbuch der Physik*, Vol. XXII., 1926.
 C. G. DARWIN. "Collision of α -particles with Light Atoms," *Phil. Mag.*, 27, p. 499, 1914.
 E. RUTHERFORD. "Collisions of α -particles with Light Atoms," *Phil. Mag.*, 37, p. 537, 1919, and 41, p. 307, 1921.
 E. RUTHERFORD and J. CHADWICK. "Bombardment of Elements by α -particles," *Nature*, 113, p. 457, 1924.
 J. CHADWICK and E. S. BIELER. "Collisions of α -particles with Hydrogen Nuclei," *Phil. Mag.*, 42, p. 923, 1921.
 E. RUTHERFORD and J. CHADWICK. "Artificial Disintegration of Light Elements," *Phil. Mag.*, 42, p. 809, 1921 ; 44, p. 417, 1922.
 W. D. HARKINS. "The Constitution and Stability of Atom Nuclei," *Phil. Mag.*, 42, p. 305, 1921.
 E. RUTHERFORD and J. CHADWICK. "Scattering of α -particles by Atomic Nuclei," *Phil. Mag.*, 50, p. 889, 1925.
 P. M. S. BLACKETT. "The Ejection of Protons from Nitrogen Nuclei," *Proc. Roy. Soc.*, 107, p. 349, 1925.
 E. S. BIELER. "The Large-angle Scattering of α -particles by Light Nuclei," *Proc. Roy. Soc.*, 105, p. 434, 1924.
 E. RUTHERFORD and J. M. NUTTALL. "Scattering of α -particles by Gases," *Phil. Mag.*, 26, p. 702, 1913.
 J. CHADWICK. "The Charge on the Atomic Nucleus and the Law of Force," *Phil. Mag.*, 40, p. 734, 1920.
 C. G. DARWIN. "A Theory of the Absorption and Scattering of α -rays," *Phil. Mag.*, 23, p. 901, 1912.
 E. RUTHERFORD. "The Scattering of α - and β -particles by Matter and the Structure of the Atom," *Phil. Mag.*, 21, p. 669, 1911.
 RABINOWITSCH and THILO. "Periodisches System" (1930).

INDEX

The roman numerals indicate the volume ; the arabic numerals refer to pages.

- a. *See* Alpha.
- Abraham, M.**, ratio of electrical units, i. 41
- Absolute temperature**, i. 59
- Absorbing power**, ii. 6
- Absorption edges in X-ray spectra**, ii. 137
of X-rays, i. 243
Discontinuities in, i. 250
- Actinium**, i. 310
Discovery of, i. 283
- Aepinus**, electric theory, i. 39
- Albedo**, i. 47
- Alpha particles**, i. 284
Charge of, i. 288
Counting, i. 288
Range of, i. 313
Tracks of, i. 317
- Analysis, Spectrum**, i. 37
- Ångström (unit)**, i. 26
- Anomalous dispersion**, i. 45
- Anomalous Zeeman effect**, ii. 131
- Anti-cathode**, i. 212
- Arago, F. D.**, wave-theory of light, i. 27
- Arc spectrum**, ii. 77
of sodium, ii. 83
- Arcadiewa, Mme.**, ether waves, i. 325
- Argon**, Electron grouping in, ii. 143
- Arnold, H. D.**, rate of fall of small spheres, i. 160
- Arrhenius, S.**, electrolytic dissociation, i. 147
- Aston, F. W.**, curve of loss of mass, i. 206
isotopes, i. 201 ; i. 311
mass spectrograph, i. 206
- Atom**, Disruption of, i. 348
ionised, ii. 65, 92
of electricity, i. 129
of hydrogen in wave mechanics, ii. 278
of the rare gases, ii. 143
Radius of, i. 268
- Atomic heat**, i. 6, 97
moment (magnetic), ii. 243
nucleus, i. 327
number, i. 232
rays, ii. 248
states. *See* States of Atom.
weights, List of, ii. 396
of isotopes, i. 205
- Atomistic doctrine**, i. 3
- Audibility, Limit of**, i. 107
- Auger, P.**, compound photoelectric effect (Auger effect), ii. 185
- Average life, Determination of**, i. 303
- Avogadro, A.**, molecular hypothesis, i. 7
- Avogadro's number**, i. 86, 124, 320 ; ii. 26
- β. *See* Beta.
- Babcock, H. D.**, specific mass of electron, ii. 126
- Back, E.**, anomalous Zeeman effect, ii. 133
- Background spectrum of X-rays**, i. 236
- Bäcklin, E.**, diffraction of X-rays, i. 243
- Balmer, J. J.**, spectral series, ii. 30
series, ii. 42
- Band spectra**, ii. 108
- Bar (unit of pressure)**, i. 106
- Barium platinocyanide**, i. 214
- Barnes, A.**, energy levels of He atom, ii. 66
- Barnett, S. J.**, magneto-mechanical effect, ii. 254
- Bartoli, A. G.**, pressure of light, i. 47
- Batho, H. F.**, light quanta and interference, ii. 218
- Beck, G.**, photoelectric effect, ii. 321
- Becquerel, H.**, radioactivity, i. 279
- Belin, E.**, photo-teleggraphy, ii. 190
- Bergmann series**, ii. 80
- Bernoulli, D.**, kinetic theory of gases, i. 51

- Bestmeyer, A.**, value of e/m , i. 183
Beta rays, i. 284, 319
Bethe, H., diffraction of electrons, ii. 299
Bjerrum, N., molecular spectra, ii. 111
Black body, ii. 2
Blackett, P. M. S., expulsion of protons, i. 358
Blake, F. C., Planck's constant, ii. 176
Bloch, E., specific heats, i. 181
Blue of the sky, i. 126
Bohr, Niels, magneton, ii. 244
 postulates regarding atomic structure, ii. 35
 shells in the atom, ii. 68
 spectral lines, ii. 31
 the Compton effect, ii. 208
Bolometer, ii. 25
Boltwood, B. B., radium in uranium minerals, i. 306
Boltzmann, L., black-body radiation, ii. 10
 entropy and probability, ii. 350
 equipartition of energy, i. 93
 kinetic theory of gases, i. 51, 111
 molecular constant, i. 61, 117
 molecular velocity, i. 65
Bonhöffer, K. F., parahydrogen, ii., 331
Born, Max, crystalline structure, i. 274
 mean free path of molecules, i. 81
 quantum mechanics, ii. 314
 specific heats, ii. 148
 theory of atom, ii. 268
 wave mechanics, ii. 307
Bose, S. N., statistics, ii. 369, 372
Bothe, W., recoil electrons, ii. 207
Boyle, R., gas pressure and volume, i. 7
Bragg, W. H., absorption of X-rays, i. 249
 path of α -particles, i. 313
 X-ray reflection from crystals, i. 256, 259
 and W. L. Bragg, crystal structure, i. 255
 spectrometer, i. 260
Braun tube, i. 137
Breadth of spectral lines, i. 64
Bridgman, P. W., pressure and electrical resistance, i. 172
Bröndsted, J. N., separation of Hg isotopes, i. 203
Broglie, Louis de, wave mechanics, ii. 269, 287
 Maurice de, Brownian movement to find e , i. 162
 X-ray spectrometer, i. 261
Brunetti, Rita, magnetic susceptibility of alkali vapours, ii. 265
Bucherer, A. H., variation of e/m with velocity, i. 144
Calcium tungstate, i. 214
Canal rays, i. 196
Candle (unit), i. 47
Canizzaro, S., atomic weights, i. 4
Carelli, A., the Raman effect, ii. 346
Cario, G., atomic collisions, ii. 101
Carnot's principle, i. 110.
Cathode ray, i. 130
 oscillograph, i. 137
Causality, Principle of, ii. 307
Cells, Photoelectric. See Photoelectric Cells.
Centred cubic lattice, i. 263
Chadwick, J., nuclear charge, i. 337
 range of protons, i. 354
Charge of α -particles, i. 288
 of electron, i. 133, 159
 nucleus, i. 337
Clausius, R., kinetic theory of gases, i. 51
Cloud method for studying ionisation, i. 150, 317
Clusius, K., specific heat of hydrogen, ii. 331
Collisions, Elastic, between atoms and electrons, ii. 85
 Inelastic, ii. 95, 100
 of first kind, ii. 100
 of second kind, ii. 101
Compton, A. H., collisions of light quanta and electrons, ii. 184, 196
Compton, K. T., collisions of atoms and electrons, ii. 89
Compton effect, ii. 184, 196
 Theory of, ii. 197
Condensation (in a gas), i. 120.
Condon, E. U., quantum theory of radioactivity, ii. 333
Conductivity of metals for heat and for electricity, i. 178 ; ii. 379
 of selenium, Photoelectric, ii. 186
 of solids, Photoelectric, ii. 186
 Theory of, i. 174
Constant of the fine structure, ii. 58
Constants, Fundamental physical, ii. 399
 h, e, m calculated from spectroscopic data, ii. 59
Contact potential, ii. 172
Coolidge tube, i. 212
Cosmic rays, i. 46

- Coster, D.**, hafnium, ii. 71
X-ray spectra, ii. 138
- Cotton, A.**, specific mass of electron, ii. 126
- Counter** for α -particles, i. 288, 291
for electrons, ii. 208
- Critical point**, i. 123
pressure, i. 74
temperature, i. 74
- Crookes, Sir Wm.**, cathode rays, i. 130
scintillation effect of α -particles, i. 290
- Crystal structure**, i. 221, 255
- Cubic lattice**, Centred, i. 263
Face-centred, i. 229, 263
Simple, i. 263
- Curie, Pierre and Marie**, i. 279
- Curie, P.**, diamagnetism, ii. 231
- Curie constant** in magnetism, ii. 236
point in magnetism, ii. 231, 243
- Current**, Ionisation, due to X-rays, i. 215
- Dalton, J.**, i. 3
law of chemical combination, i. 5
- Darwin, C. G.**, reflection of X-rays from crystals, i. 259
- Davis, Berghen**, excitation potentials, ii. 98
- Davison, C. J.**, diffraction of electrons, ii. 295
thermionic emission, i. 187
- Debiere, A.**, discovery of actinium, i. 283
- Debye, P.**, the Compton effect, ii. 196
theory of specific heats, ii. 149
X-rays and crystal structure, i. 265, 269
- De Forest, L.**, thermionic valve, i. 192
- Degeneracy**, ii. 353, 358
criterion of, ii. 364
- De Haas**. See Haas.
- Democritus**, i. 3
- Dempster, A. J.**, emission of atoms, ii. 105
light quanta and interference, ii. 218
mass spectrograph, i. 201, 208
- Dennison, P. M.**, specific heats, ii. 327
- Depth measurement** by piezo-electricity, i. 277.
- Descartes, René**, i. 23
- Determinism**, i. 302
- Devaux, H.**, oil films, i. 19
- Diamagnetism**, ii., 231
and the periodic system, ii. 235
- Diameter**, Molecular, i. 71, 87
- Dielectric constant**, i. 40
- Diffraction of light**, i. 26
fringes, i. 26
grating, i. 28
of electrons, ii. 295
of X-rays, i. 217, 243
- Diffuse series** in spectrum, ii. 80
- Discontinuity of light**, i. 125. See also Scattering.
- Diode**, i. 191
- Dirac, P. A. M.**, quantum mechanics, ii. 314
statistics, ii. 357
theory of atom, ii. 268
- Disc**, Nipkow, ii. 193
- Discontinuity** in absorption of X-rays, i. 250
- Disintegration of atom**, Artificial, i. 348
Radioactive, i. 295
- Dispersion of light**, i. 45; ii. 338
- Displacement current**, i. 40
law in radioactivity, i. 308
- Disruption of atom**, i. 348
- Disruptive discharge**, i. 149
- Dobronrawoff, N.**, light quanta, ii. 213
- Donati, G. B.**, spectra of stars, i. 38
- Doppler effect**, i. 36, 64
- Droplets** in equilibrium used to determine e , i. 154
- Drude, P.**, reflection of X-rays from crystals, i. 259
theory of conduction, i. 175, 179
- Duane, W.**, Planck's constant h , ii. 176
wave-length of X-rays, ii. 104
and Hunt's equation, ii. 104
- Dulong and Petit**, law of atomic heats, i. 6, 97
- Dushman, S.**, manometer, i. 107
thermionic emission, i. 187, 191
- Earth lines** in solar spectrum, i. 38
- Echelon grating** of Michelson, i. 31
- Edison, T. A.**, thermionic emission (Edison effect), i. 181
- Eigenvalues** (in wave mechanics), ii. 276
- Einstein, Albert**, general law of fluctuations, i. 119
magneto-mechanical effect, ii. 252
momentum of light quant, ii. 197
photoelectric effect, ii. 164
specific heats, ii. 147
theory of light quant, ii. 209
theory of opalescence, i. 127

- Electrolysis**, i. 15
- Electron**, i. 130
 Charge of, i. 133, 159
 Distribution of, in shells, ii. 68
 Free, in wave-mechanics, ii. 285
 gas, ii. 103
 mass of, i. 133, 139
 Number of peripheral, and Thomson's theory, i. 338
 radius of, i. 145
 recoil (in Compton effect), ii. 202
 rotating, ii. 130
- Elliptic orbits**, Theory of, ii. 53
- Ellis, C. D.**, wave-length of γ -rays, ii. 179
- Elsasser, W.**, diffraction of electrons, ii. 296
- Emanation from radium**, i. 292, 321.
See also Radon.
- Emeléus, G. K.**, beta rays, i. 287
- Emission spectra**, i. 37
 Spectral, ii. 91
- Emissive power**, ii. 6
- Energy emitted from radium**, i. 322
 Equipartition of, i. 61
 fluctuations and quantum theory, ii. 215
 levels, i. 239
 in hydrogen atom, ii. 61
 in the nucleus, ii. 180
 of the atoms, ii. 45
 X-ray, ii. 103
 Mean kinetic, of a molecule, i. 87
 Molecular, i. 60
 of matter, Internal, i. 322
 Resonance, ii. 90
- Entropy**, i. 110
 of a monatomic perfect gas, ii. 350, 353
- Epicurus**, i. 3
- Epstein, P. S.**, the Stark-Lo Surdo effect, ii. 117
- Equipartition of energy**, i. 61, 90
- Errors**, Gaussian law of, i. 55.
- Ether**, i. 42
 waves, i. 323
- Eucken, A.**, specific heat of hydrogen, ii. 331
- Euler, L.**, i. 23
- Ewald, P. P.**, reflection of X-rays from crystals, i. 259
- Excitation of atom**, ii. 64
 potential, ii. 97
 Thermal, of atoms, ii. 90
- Excited states of atom**, ii. 64
- Exclusion principle**, ii. 139, 358, 368, 389
- Face-centred cubic lattice**, i. 229, 263
- Fajans, K.**, displacement law, i. 308
- Faraday, M.**, electromagnetic induction, i. 40
 laws of electrolysis, i. 129
- Fermi, Enrico**, atomic structure, ii, 71
 statistics, ii, 357
- Ferromagnetism**, ii. 243
- Filament of thermionic valve**, i. 191
- Fine structure of Rontgen spectra**, ii. 137
 of spectral lines, ii. 58, 115
- Fizeau, H. L.**, velocity of light, i. 32
- Fleming, Sir A. P.**, thermionic emission, i. 182
 thermionic valve, i. 191
- Fletcher, H.**, Brownian movement to find e , i. 163
- Flow from small orifices**, i. 63
- Fluctuations**, i. 110, 114
 General law of, i. 119
 of energy and quantum theory, ii. 215
 of radioactive phenomena, i. 301
- Fluorescence**, ii. 99, 343
- Fluorescin**, i. 18
- Fluorite**, Lattice structure of, i. 266
- Foote, P. D.**, excitation and ionisation potentials, ii. 97
- Fortrat, R.**, specific mass of electron, ii. 126
- Foucault, L.**, velocity of light, i. 32
- Fowler, A.**, spectral series, ii. 46
- Franck, J.**, atomic collisions, ii. 101
 Bohr's theory, ii. 93
- Franklin, Benjamin**, electric theory, i. 39
- Franz, J.**, law of conductivities, i. 177
- Fraunhofer, J.**, grating, i. 28
 lines in solar spectrum, i. 38
- Free path of molecules**, i. 78, 80
- Frequency of piezoelectric plate**, i. 276
 Supersonic, i. 276
- Fresnel, A.**, wave theory of light, i. 23
- Friedrich, W.**, diffraction of X-rays by crystals, i. 219
- Fuchsin**, i. 17
- γ . *See* Gamma.
- Gadolinium sulphate and Langevin's law**, ii. 241
- Gaede, W.**, molecular pump, i. 104
- Galileo**, velocity of light, i. 31.
- Gamma-rays**, i. 47, 284
 wavelength of, ii. 178

- Gassendi, Pierre**, i. 3
- Gauss, K. F.**, law of errors, i. 55
- Gay-Lussac, L. J.**, cooling by expansion, i. 76
thermal expansion of gases, i. 7
- Geiger, H.**, counting α -particles, i. 292
nuclear charge and atomic number, i. 337
range of α -particles, i. 315
rate of emission of α -particles, i. 301
scattering of α -particles, i. 335
the Compton effect, ii. 208
- Geiger's law**, i. 315
- Gerlach, W.**, the Bohr magneton, ii. 247
- Germer, L. H.**, diffraction of electrons, ii. 295
thermionic emission, i. 187
- Gibbs, W.**, i. 113
- Gilbert, W.**, magnet, i. 39
- Glocker, R.**, testing materials with X-rays, i. 253
- Goldschmidt, E.**, canal rays, i. 196
- Gordon, W.**, the Compton effect, ii. 322
- Goucher, F. S.**, excitation potentials, ii. 98
- Goudsmit, S.**, magnetic moment of electron, ii. 129
- Gramme-atom**, i. 6
- Gramme-molecule**, i. 6
- Graphite**, Space-lattice of, i. 266
- Grating**, Diffraction, i. 28
Echelon, i. 31
for X-ray spectrography, i. 240
- Grid** of thermionic valve, i. 192
voltage of valve, i. 194
- Grimaldi, Padre**, interference, i. 24
- Groups**, Radioactive, i. 294
- Gurney, R. W.**, beta rays, i. 287
quantum theory of radioactivity, ii. 333
- Guye, C. E.**, variation of e/m with velocity, i. 145
- h*. See Planck's Constant.
- Haas, W. J. de**, magneto-mechanical effect, ii. 252
- Hafnium**, ii. 71
- Half-value** period of radioactive substances, i. 297
- Hallwachs, W.**, photoelectric effect, ii. 162
- Harkins, W. D.**, Rules of, i. 345
- Harteck, P.**, parahydrogen, ii. 331
- Hauy, R. J.**, piezoelectricity, i. 274
- Heat** radiated from radium, i. 307
Specific, of gases, i. 90
of solids, i. 96
- Heisenburg, W.**, hydrogen atom, ii. 317
indeterminacy principle, ii. 309
quantum mechanics, ii. 314
theory of atom, ii. 268
- Heitler, W.**, energy of H molecule, ii. 322
- Helium** from radium, i. 295
Grouping of electrons in, ii. 143
Spectrum of ionised, ii. 45
- Heller, K.**, specific heat of hydrogen, ii. 331
- Helmholtz, H. von**, atomic nature of electricity, i. 16, 129
- Hertz, G.**, Bohr's theory, ii. 93
- Hertz, Heinrich**, electromagnetic waves, i. 42
- Hertzian waves**, i. 46.
- Hevesy, G.**, radioactive transformation constant, i. 316
separation of Hg isotopes, i. 203
- Hjalmar, E.**, reflection of X-rays from crystals, i. 260
- Holweck, M. F.**, diffraction of X-rays, i. 243
ether waves, i. 325
molecular pump, i. 105
- Houston, W. V.**, heat conductivity, ii. 383
- Hunt, F. L.**, Planck's constant h , ii. 176
wave theory of X-rays, ii. 104
- Huyghens, C.**, wave theory of light, i. 23
- Hydrogen** atom in wave-mechanics, ii. 278
Change of electron mass with velocity in, ii. 56
Specific heat of, i. 91
spectrum, ii. 41
Fine structure of, ii. 58
- Imes, E. S.**, molecular spectra, ii. 111
- Indeterminacy**, Principle of, ii. 309
- Index** of refraction, i. 43
- Infra-red** radiation, i. 47
- Interference**, i. 24
between light quanta, ii. 218
fringes, i. 26
of light waves, i. 24
- Interferometer** of Michelson, i. 35
- Intrinsic** potential, ii. 385
- Inversion** temperature, i. 78
- Ionisation** current due to X-rays, i. 215
potential, ii. 93
Second order, ii. 100

- Ionised helium, Spectrum of**, ii. 45
Ionium, i. 297
Ions, i. 147
Isobares, i. 344
Isochromatic curves for X-rays, i. 237
Isothermal enclosure, ii. 6
Isotopes, i. 9, 196, 308, 344
 and molecular spectra, ii. 111
 Atomic weights of, i. 205
- Jeans, Sir J.**, black body radiation, ii. 25
 kinetic theory of gases, i. 51
Joffé, A., light quanta, ii. 213
Jordan, P., quantum mechanics, ii. 314
Jordan, P., theory of atom, ii. 268
Joule, J. P., kinetic theory of gases, i. 51
Joule-Thomson, effect, i. 76
- Kallman, H.**, the Compton effect, ii. 201
Kamerlingh-Onnes, H., specific heats, ii. 154
 super-conductivity, i. 170
Kapitza, P., anomalous Zeeman effect, ii. 132
Karman, Th. von, specific heats, ii. 148
Kathode. *See* Cathode.
Kaufmann, W., variation of e/m with velocity, i. 142
Keesom, W. H., opalescence, i. 125
 solidification of helium, i. 306
Kellner, G. W., helium atom, ii. 316
Kelvin, Lord, Joule-Thomson effect, i. 76
 ratio of electrical units, i. 41
Kenotron, i. 192
Kichuchi, S., diffraction of electrons, ii. 303
Kinematography from a distance, ii. 195
Kirchhoff, G. B., black body radiation, ii. 7
 kinetic theory of gases, i. 51
Kirsch, G., disintegration of atom, i. 357
Klein, O., collisions of second kind, ii. 100
Knipping, P., diffraction of X-rays by crystals, i. 219
Knudsen, K., flow of gas through a tube, i. 98, 99, 102
Kohlransch, F. W., i. 41
Kovarik, A. F., magnetic spectra, i. 319
Kramers, H. A., the Compton effect, ii. 208
Krönig, A., kinetic theory of gases, i. 51
- Krypton, Electron grouping in**, ii. 143
Kundt, A. A., flow of gases through tubes, i. 97
- Lambert (unit)**, i. 47
Landé, A., splitting factor, ii. 135, 316
Langevin, P., paramagnetism, ii. 236
 piezo-electricity, i. 278
Langmuir, I., thermionic emission, i. 188
Larmor, J., precession of electron, ii. 122
Larsson, A., reflection of X-rays from crystals, i. 260
Lattice. *See* Space-lattice.
 planes in crystals, i. 222
Laue, M. von, diffraction of X-rays by crystals, i. 217
 nature of X-rays, i. 216
Laue diagram, i. 228
Lavanchy, Ch., variation of e/m with velocity, i. 145
Lavoisier, i. 3
Lead (in radioactivity), i. 313
Lenard, P., mean free path of electrons, i. 165
 velocity of photo-electrons, ii. 162
Lenz, W., molecular spectra, ii. 111
Leu, A., magneton, ii. 251
Leucippus, i. 3.
Levels, Energy, i. 239. *See also* Energy Levels.
Lewis, G. N., photon, ii. 211
Life, Average, of radioactive substances, i. 297
Light quanta, ii. 167, 183, 209
 vector, i. 43
 Velocity of, i. 31, 43
 Visible, i. 47
Light-sensitive cells, ii. 186
Limit of audibility, i. 107
 of background spectrum for X-rays, i. 236
Lindemann, F. A., atomic heats, ii. 155
Lockyer, Sir N., discovery of helium, i. 38
London, F., energy of H_2 molecule, ii. 322
Loomis, F. W., ortho- and para-molecules, ii. 324
Lorentz, H. A., kinetic theory of gases, i. 51
 law of conductivities, i. 178 ; ii. 379
 reflection of X-rays from crystals, i. 259
 theory of conduction, i. 48

- Loss of mass**, i. 204
Lo Surdo, A., spectral lines, ii. 115
Lumen (unit), i. 47
Luminous quanta, ii. 167
 vector, i. 43
Lyman, Th., ether waves, i. 325
 spectral series, ii. 43
Lyman rays, i. 47
- Magnetic field**, Molecular, ii. 242
 moment, ii. 229
 of atom, ii. 243
 of gramme-atom, ii. 240, 246
 of hydrogen atom, ii. 254
 quantum number, ii. 128
 spectra, i. 319 ; ii. 176
Magnetisation, Coefficient of, ii. 230
Magnetism, ii. 228
Magneton, ii. 127
 Bohr's, ii. 244
Manometer, Absolute, i. 104
 for low pressures, i. 107
 Molecular, i. 103
Mariotte, E., gas pressure and volume,
 i. 7
Mark, H., the Compton effect, ii. 201
Marsden, E., atomic disintegration, i.
 351
 nuclear charge and atomic number,
 i. 337
 scattering of α -particles, i. 335
Mass, Loss of, i. 204
 of electron, i. 133, 139
 spectrograph, i. 198
 spectrum, i. 201
Maxwell, J. C., electromagnetic theory
 of light, i. 40
 equations of electromagnetic field,
 i. 42
 equipartition of energy, i. 93
 flow of gas through a tube, i. 97
 kinetic theory of gases, i. 51
 law of molecular velocities, i. 53
 pressure of light, i. 47
Maxwell's "demon," i. 111
Mayer, H. F., mean free path of
 electrons, i. 165
Mean free path of molecules, i. 78, 80
 square of molecular velocities, i. 57
Mechanics, Statistical, i. 110
 Wave, ii. 276
Meitner, L., energy levels of nucleus, ii.
 180
 magnetic spectra, ii. 177
- Mendeleieff, D. I.**, classification of
 elements, i. 10, 203
Merritt, E., photoelectric effect, ii. 162
Michelson, A. A., echelon grating, i. 31
 interferometer, i. 35
 velocity of light, i. 33
Micron = 10^{-4} cm., i. 47
Millikan, R. A., electronic charge, i.
 154
 photoelectric effect, ii. 170
Millimicron = 10^{-3} micron, i. 47
Mobility of gaseous ions, i. 149
Mohler, F. L., excitation and ionisation
 potentials, ii. 97
Molecular diameters, i. 86
 energy, i. 60
 magnetic field, ii. 242
 rotation, ii. 156
 spectra, ii. 108
 and isotopes, ii. 111
 velocity in a gas, i. 53, 60
 Mean square of, i. 57
Molecules, size of, i. 17
Moments, Atomic (magnetic), ii. 243
 Magnetic, ii. 229
 of inertia of molecules, ii. 157
Moseley, H. G. J., X-ray spectra, i. 229 ;
 ii. 75
Multiplets in Zeeman effect, ii. 133
- Nebulium**, ii. 33
Neon, Electron grouping in, ii. 143
 lamp in television, ii. 194
Nernst, W., specific heat of gas, i. 96
 specific heats at low temperatures,
 ii. 146
Neumann, F. E., law of molecular heats,
 i. 6
Newton, Sir I., experiments on soap
 films, i. 18, 25
 interference rings, i. 26
Nichols, E. F., ether waves, i. 325
Nicol prism, i. 27
Nipkow, P., disc for television, ii. 193
Niton, i. 297. *See also* Radon.
Nodes of crystal space-lattice, i. 223
Normal states of atom, ii. 64
Nucleus and surrounding electrons, i.
 340
 Atomic, i. 327
 Charge of, i. 337
 Motion of, ii. 46
 Size of, i. 340
Nuttall, J. L., path of α -particle, i. 316

- Oersted, H. C.**, electromagnetism, i. 40
Opacimetry by photo-cells, ii. 190
Opalescence, Critical, i. 124
Orbits, Elliptic, in hydrogen atom, ii. 51
 of hydrogen electron, ii. 113
 Theory of, ii. 53
 of electron in hydrogen atom, ii. 40
Order of interference, Limiting, i. 67
Orthohydrogen, ii. 331
Ortner, G., expulsion of protons, i. 358
Oscillator in wave mechanics, ii. 282
 Valve, i. 194
Oscillograph, Cathode ray, i. 137

 ψ . See entry under Psi.
Packing effect, i. 204
Paneth, F., range of α -particle, i. 316
Parahydrogen, ii. 323, 331
Paramagnetism, ii. 235
 of alkali metals, ii. 388
Paschen, F., anomalous Zeeman effect, ii. 133
 Rydberg constant, ii. 50
 spectral series, ii. 43
Paschen-Back effect, ii. 133
Path of α -particles, i. 313
Pauli, W., exclusion principle, ii. 139, 358, 368, 389
Penetrability of X-rays, i. 253
Penetrating power of radioactive radiations, i. 286
Period, Half-value, of radioactive substances, i. 297
Periodic classification of elements, i. 13
 system, ii. 139
Peripheral electrons, Number of, and Thomson's theory, i. 338
Permanence of atoms in their quantum states, ii. 105
Permeability (magnetic), i. 40
Perrin, Jean, cathode rays, i. 131
 measurement of soap films, i. 18
Petit and Dulong. See Dulong and Petit.
Pettersson, H., disintegration of atom, i. 357
Phipps, T. E., magnetic moment of H atom, ii. 254
Photoelectric cells, ii. 188
 Applications of, ii. 188
 of resistance type, ii. 186
 Sensitisation of, ii. 187
 conductivity of solids, ii. 186
 effect, ii. 162
 threshold, ii. 163

Photo-electrons, ii. 164
Photons, ii. 209
Photo-telegraphy, ii. 190
Pickering, E. C., spectral series, ii. 46
Pierce, S. E., absorption of X-rays, i. 249
Piezoelectricity, i. 274
Pile, Thermoelectric, ii. 26
Pitchblende, i. 283
Planck, Max, quantum theory, ii. 3
Planck's constant h , i. 238 ; ii. 4
 Determination of, by photoelectric effect, ii. 173
 Various determinations of, ii. 182
 formula, ii. 19, 22
Planes, Lattice, i. 223
Plate current, i. 194
 of thermionic valve, i. 192
 potential in thermionic valve, i. 194
Platinocyanide of barium, i. 214
Poincaré, H., degrees of freedom, i. 94
 radioactivity, i. 279
Poiseuille, J. L., law of flow of fluids, i. 84, 97
Poisson, S. D., probability law, i. 300
Polarisation of light, i. 27
 of X-rays, i. 243
Polonium, Discovery of, i. 283
Positive rays, i. 196
Postulates of Bohr regarding atomic structure, ii. 35
Potential, Contact, ii. 172
 Excitation, ii. 97
 Intrinsic, ii. 385
 Ionisation, ii. 93
 of plate in thermionic valve, i. 194
 Second order ionisation, ii. 100
Precession of Larmor, ii. 122
Precision of wave-length measurements, i. 34
Preece, W. H., thermionic emission, i. 182
Pressure, Critical, i. 74
 of degenerate gas, ii. 361
 of gas, i. 58
 of light, i. 47
 of radiation, ii. 5
Probability, i. 110, 116
 in radioactivity, i. 298
Protons, Range of, i. 353
Proust, J. L., law of combination, i. 4
Prout, W., integral atomic weights, i. 8
 nature of matter, i. 203
Przibram, K., charge of electron, i. 164
 ψ -function in wave mechanics, ii. 304

- Pugno-Vanoni, Enzo**, applications of X-rays, i. 254
- Pumps for high vacua**, i. 104
Gaede's, i. 104
Holweck's, i. 105
- Pyrites**, Space lattice of, i. 268
- Quantisation**, Spatial, ii. 124
- Quants**, Light, ii. 167, 183, 209
- Quantum**, Azimuthal, ii. 54, 81, 124
number, Magnetic, ii. 128
Total, ii. 54, 79
Radial, ii. 54, 81, 124
theory of radioactivity, ii. 332
- Quartets** in Zeeman effect, ii. 135
- Quartz**, Piezoelectric, i. 274
- Radiation from radioactive bodies**, i. 284
Pressure of, ii. 5
- Radioactive constant**. *See* Transformation constant.
disintegration, Law of, i. 296
elements, i. 294
equilibrium, i. 303
evolution, i. 295
- Radioactivity**, i. 279
and probability, i. 298
Quantum theory of, ii. 332
- Radiograph**, Laue, i. 220
of rock-salt, i. 227
of sylvine, i. 227
- Radiography**, i. 214, 251
- Radio-metallography**, i. 253
- Radiometry**, ii. 25
- Radioscopy**, i. 251
- Radiotelegraphy**, i. 192
- Radiotelephony**, i. 194
- Radium B**, i. 296
- Radium C**, i. 296
- Radium C'**, i. 315
- Radius of atom**, i. 268
of electron, i. 145
of electronic orbit in hydrogen atom, ii. 40
of hydrogen atom, ii. 44
- Radon** (radium emanation), i. 292, 297
Electron grouping in, ii. 143
- Raman, C. V.**, scattering of light (Smekal-Raman effect), ii. 339
- Ramsauer, C.**, mean free path of electrons (Ramsauer effect), i. 164
- Ramsay, Sir Wm.**, transmutation of elements, i. 348
- Range of α -particles**, i. 313
of protons, i. 353
- Rare earths** in Bohr's theory, ii. 71
- Rasetti, F.**, the Raman effect, ii. 346
- Rayleigh, Lord**, black body radiation, ii. 25
blue of the sky, i. 126
kinetic theory of gases, i. 51
- Rayleigh-Jeans formula**, ii. 161
- Recoil atoms**, i. 321
electrons, ii. 202
- Refractive index**, i. 43
- Regener, E.**, counting α -particles, i. 290
- Relativistic theory of hydrogen atom**, ii. 56
- Relay, Valve**, i. 193
- Resistance**, Electrical, of metals, i. 168
photoelectric cells, ii. 186
- Resonance**, ii. 99
energy, ii. 90
- Richardson, O. W.**, thermionic emission, i. 185
magneto-mechanical effect, ii. 252
- Richtmyer, F. K.**, absorption of X-rays, i. 250
- Riecke, E.**, theory of conduction, i. 175
- Righi, August**, photoelectric effect, ii. 162
saturation current, i. 149
- Ritz, W.**, spectral series, ii. 30
- Ritz correction**, ii. 82
- Robinson, H.**, magnetic spectra, ii. 177
- Rock-salt**, Space-lattice of, i. 229
- Roemer, O.**, velocity of light, i. 31
- Röntgen, W. G.**, i. 212
- Röntgen (unit)**, i. 252
rays. *See* X-rays.
- Rosa, E. B.**, and N. E. Dorsey, ratio of electrical units, i. 41
- Rosseland, S.**, collision of second kind, ii. 100
- Rotating electron**, ii. 130
- Rotation of molecules**, ii. 156
of sun, i. 37
- Rotator in wave mechanics**, ii. 284
- Roth, A.**, susceptibility of alkali vapours, ii. 262
- Rowland, H. A.**, diffraction grating, i. 28
ratio of electrical units, i. 41
- Rubinowicz, A.**, selection rule, ii. 127
- Rupp, E.**, diffraction of electrons, ii. 303
- Russell, H. N.**, displacement law, i. 308
- Rutherford, E.**, charge and mass of α -particle, i. 289
condensation of radon, i. 293

- Rutherford, E.**, counting α -particles, i. 301
 disintegration of elements, i. 348, 351
 passage of α -particles through atoms, i. 330
 radium in uranium minerals, i. 306
 range of protons, i. 353
 scattering of α -particles, i. 331
 theory of atomic structure, i. 327, 344, 358
- Rydberg, J. R.**, spectral series, ii. 30, 82
- Rydberg constant**, ii. 42, 49
 correction, ii. 82
 formula, ii. 82
- Saturation current** in ionised gas, i. 149
 curve of thermionic emission, i. 188
- Scattering of light**, ii. 339
 of X-rays by crystals, i. 217
- Scherrer, P.**, X-rays and crystal structure, i. 265, 269
- Schmidt, G. C.**, disintegration of atom, i. 357
- Schottky, W.**, electronic charge, i. 194
- Schrödinger, E.**, atomic heats, ii. 153
 wave mechanics, ii. 269, 273
- Schumann, V.**, ether waves, i. 325
- Schumann rays**, i. 47
- Schwarzschild, K.**, the Stark-Lo Surdo effect, ii. 117
- Schweidler, E.**, fluctuations of radioactive phenomena, i. 301
- Secchi, A.**, spectra of stars, i. 38
- Selection rule**, ii. 127
- Selective photoelectric effect**, ii. 187
- Selenium**, Photoelectric conductivity of, ii. 186
- Sella, Quintino**, i. 128
- Sensitization of photoelectric cells**, ii. 187
- Separation factor** (Landé). *See* Splitting factor.
- Series, Balmer's**, ii. 42
 Bergmann's, ii. 80
 Diffuse, in spectrum, ii. 80
 Fowler's, ii. 46
 Lyman's, ii. 43
 Paschen's, ii. 43
 Pickering's, ii. 46
 Principal, in spectrum, ii. 80
 Sharp, in spectrum, ii. 80
- Sharp, H.**, the Compton effect, ii. 201
- Sharp series**, in spectrum, ii. 80
- Shells, Electron**, ii. 68, 142
- Siegbahn, M.**, refraction of X-rays, i. 215
- Skinner, H. W. B.**, wavelength of γ -rays, ii, 180
- Slater, J. C.**, the Compton effect, ii. 208
- Smekal, A.**, scattering of light (Smekal-Raman effect), ii. 339
 X-ray spectra, ii. 138
- Smoluchowski, M.**, theory of density fluctuations, i. 120
- Soddy, F.**, condensation of radon, i. 293
 displacement law, i. 308
 isotopes, i. 202
- Sodium, Arc spectrum of**, ii. 83
- Sommerfeld, A.**, conductivities of metals, ii. 379
 electron orbits, ii. 51, 53
 selection rule, ii. 127
 specific heats, i. 181
- Space-lattice, Crystalline**, i. 221
 dimensions for sodium chloride, i. 258
 of metals, i. 266
 of rock-salt, i. 229,
 of sylvine, i. 229
- Spark discharge**, ii. 149
 spectra, ii. 77, 93
- Specific heat, C_p** , i. 91
 C_v , i. 90
 Debye's theory of, ii. 149
 of gases, i. 90
 of hydrogen, i. 91
 of solids, i. 96
- Spectral analysis**, i. 37
 emission, ii. 91
 lines, Breadth of, i. 64
 term of atom, ii. 65
- Spectrograph**, i. 38
 Aston's, i. 206
 Dempster's, i. 208
 Mass, i. 198
- Spectrometer for X-rays, Bragg's**, i. 260
 De Broglie's, i. 261
- Spectroscopy**, ii. 30
- Spectrum, Arc**, ii. 77
 Band, ii. 108
 Continuous X-ray, ii. 174
 Emission, i. 37
 Magnetic, i. 319
 Mass, i. 201
 Molecular, ii. 108
 Spark, ii. 77, 93
 X-ray, i. 229; ii. 72
- Speech, Power dissipated in**, i. 107

- Sphere of action**, i. 71
Spintharoscope, i. 288
Splitting factor (Landé), ii. 135, 316
Spurs of α -particle tracks, i. 318
Stark effect and wave mechanics, ii. 281
Stark-Lo Surdo effect, ii. 115
States of atom, Excited, ii. 64
 Normal, ii. 64
 Stationary, ii. 64
Stationary state of atom, ii. 64
Statistical mechanics, i. 110
Statistics, Bose's, ii. 369, 373
 Fermi's, ii. 357
 New, ii. 350
Stefan, J., black body radiation, ii. 10
Stern, Otto, direct measure of molecular velocity, i. 69
 magneton of Bohr, ii. 247
Stetter, G., expulsion of protons, i. 358
Stokes, Sir G. G., law of fall of spherical particles, i. 85
 rule for fluorescence, ii. 343
Stoletow, A. G., photoelectric effect, ii. 162
Stoner, E. C., atomic theory, ii. 70
Stoney, J., atomic nature of electricity, i. 129
Structure, Fine, of spectral lines, ii. 58, 115
 of Rontgen spectra, ii. 137
Sun, Rotation of, i. 37
 Temperature of, ii. 13, 18
Superconductivity, i. 168
Supersonics, i. 274
 frequencies, i. 276
Susceptibility, Magnetic, ii. 231
Sutherland, W., manometer, i. 107
- Tails of α -particle tracks**, i. 318
Taylor, G. I., light quants and interference, ii. 218
 magneton, ii. 251
Taylor, J. B., magnetic moment of H atom, ii. 254
Tear, J. D., ether waves, i. 325
Telekinematograph, ii. 195
Telephotography. *See* Photo-telegraphy.
Television, ii. 192
Temperature, Absolute, i. 59
 Critical, i. 74
 Inversion, i. 78
Term, Spectral, of atom, ii. 65
Thales of Miletus, i. 3, 39
- Thermal conductivity and electrical conductivity**, i. 175
 excitation of atoms, ii. 90
Thermionic effect, i. 181
 and quantum statistics, ii. 384
 emission, Theory of, i. 185
 valve, i. 191
Thermopile, ii. 26
Thibaud, J., grating spectrograph for X-rays, i. 240
Thomson, G. P., diffraction of electrons, ii. 300, 303
Thomson, J. J., atomic structure, i. 338
 measurement of e/m , i. 134
 positive rays, i. 198
Thomson effect, i. 76
Thorium, i. 310
Threshold, Photoelectric, ii. 163
Townsend, J. S., electronic charge, i. 151
Transformation constant in radio-activity, i. 296
Trillat, J. H., testing materials with X-rays, i. 253
Triode, Characteristics of, i. 194
 circuits, i. 192
Triplets in Zeeman effect, ii. 135
Tuyn, A., superconductivity, i. 171
- Uhlenbeck, G. E.**, magnetic moment of electron, ii. 129
Ultra-violet radiation, i. 47
Uncertainty principle, ii. 309
Uranium, i. 297
 series, i. 297, 309
- Valve**, Thermionic, i. 191
 with three electrodes, i. 192
 with two electrodes, i. 191
Van den Broeck, A., nuclear charge and atomic number, i. 337
Van der Waals, Equation of, i. 71, 73
 kinetic theory of gases, i. 51
Vector, Luminous, i. 43
Velocity, Molecular, in various gases, i. 60
 of light, i. 31, 43
Viscosity of gases, i. 83
 Coefficient of, i. 85, 87
Volta, A., kinetic theory of gases, i. 51
Volta effect and new statistics, ii. 387
- Waals**. *See* Van der Waals.
Wagner, E., Planck's constant, ii. 176

- Wang, S. C.**, energy of H molecule, ii. 322
Warburg, E., flow of gases through tubes, i. 97
Wave-length measurements, Precision of, i. 34
 of γ -rays, ii. 178
 of X-rays, i. 215
Wave mechanics, ii. 276
Wave-number, ii. 41
Wave theory of light, i. 23
Weber, W., i. 41
Wehnelt, A., oxide-coated cathode, i. 184
 value of e/m , i. 183
Weiss, P., paramagnetism, ii. 242
Wentzel, G., X-ray spectra, ii. 138
Wiedemann, G. H., law of conductivities, i. 177
Wiedemann-Franz law, i. 49, 177
Wien, W., black-body radiation, ii. 14, 24
 emission of atoms, ii. 105
 positive rays, i. 197
Wilson, C. T. R., cloud apparatus, i. 150, 317
Wilson, C. T. R., passage of α -particle through atoms, i. 328
 recoil electrons, ii. 207
 tracks of α -particles, i. 317
Wilson, H. A., electronic charge, i. 151
Wood, R. W., piezoelectricity, i. 278
 ortho- and para-molecules, ii. 324
Xenon, Electron grouping in, ii. 143
X-rays, i. 212
 Absorption of, i. 243
 Hard, i. 214
 Penetrating power of, i. 253
 Polarisation of, i. 243
 Practical applications of, i. 251
 Soft, i. 214
 spectra, i. 229 ; ii. 72
 tubes, i. 212
 Wave-length of, i. 215
X-unit = 10^{-11} cm., i. 232
Young, Thomas, i. 25
Zeeman effect, Anomalous, ii. 131
 Normal, ii. 121

