

TIGHT BINDING BOOK

UNIVERSAL
LIBRARY

OU 160776

UNIVERSAL
LIBRARY

OUP--23--4-4-69--5,000.

OSMANIA UNIVERSITY LIBRARY

Call No. 532 Accession No. 8236

Author G41H
 J. J. Zeebroek

Title Mechanics Hydrostatics

This book should be returned on or before the date
last marked below.

MECHANICS

HYDROSTATICS

**AN ELEMENTARY TEXT-BOOK
THEORETICAL AND PRACTICAL**

BY

R. T. GLAZEBROOK, M.A., F.R.S.

**DIRECTOR OF THE NATIONAL PHYSICAL LABORATORY,
FELLOW OF TRINITY COLLEGE, CAMBRIDGE.**

**CAMBRIDGE:
AT THE UNIVERSITY PRESS.**

1916

First Edition 1895
Reprinted 1896, 1900, 1903
1904, 1908, 1911, 1916

PREFACE.

IT has now come to be generally recognised that the most satisfactory method of teaching the Natural Sciences is by experiments which can be performed by the learners themselves. In consequence many teachers have arranged for their pupils courses of practical instruction designed to illustrate the fundamental principles of the subject they teach. The portions of the following book designated EXPERIMENTS have for the most part been in use for some time as a Practical Course for Medical Students at the Cavendish Laboratory.

The rest of the book contains the explanation of the theory of those experiments, and an account of the deductions from them. This part has grown out of my lectures to the same class. It has been my object in the lectures to avoid elaborate apparatus and to make the whole as simple as possible. Most of the lecture experiments are performed with the apparatus which is afterwards used by the class, and, whenever it can be done, the theoretical consequences are deduced from the results of these experiments.

In order to deal with classes of considerable size it is necessary to multiply the apparatus to a large extent. The

students usually work in pairs and each pair has a separate table. On this table are placed all the apparatus for the experiments which are to be performed. Thus for a class of 20 there would be 10 tables and 10 specimens of each of the pieces of apparatus. With some of the more elaborate experiments this plan is not possible. For them the class is taken in groups of five or six, the demonstrator in charge performs the necessary operations and makes the observations, the class work out the results for themselves.

It is with the hope of extending some such system as this in Colleges and Schools that I have undertaken the publication of the present book and others of the Series. My own experience has shewn the advantages of such a plan, and I know that that experience is shared by other teachers. The practical work interests the student. The apparatus required is simple; much of it might be made with a little assistance by the pupils themselves. Any good-sized room will serve as the Laboratory. Gas should be laid on to each table, and there should be a convenient water supply accessible; no other special preparation is necessary.

The plan of the book will, I hope, be sufficiently clear; the subject-matter of the various Sections is indicated by the headings in Clarendon type; the Experiments to be performed by the pupils are shewn thus:

EXPERIMENT (1). *To determine directly the specific gravities of various substances.*

These are numbered consecutively. Occasionally an account of additional experiments, to be performed with the same apparatus, is added in small type. Besides this the small-type articles contain some numerical ex-

amples worked out, and, in many cases, a notice of the principal sources of error in the experiments, with indications of the method of making the necessary corrections. These latter portions may often with advantage be omitted on first reading. Articles or Chapters of a more advanced character, which may also at first be omitted, are marked with an asterisk.

I have to thank many friends for help. Mr Wilberforce and Mr Fitzpatrick have assisted in arranging and devising many of the experiments. Mr Fitzpatrick has also read all the proofs. My pupil, Mr G. G. Schott of Trinity College, collected for me many of the Examples, while Mr Green of Sidney College has most kindly worked through all and furnished me with the answers.

The illustrations have for the most part been drawn by Mr Hayles from the apparatus used in the class.

R. T. GLAZEBROOK.

CAVENDISH LABORATORY,
October, 1895.

CHAPTER I.

STATES OF MATTER.

1. Solids and Fluids.

In **Dynamics** and **Statics** we have dealt with some parts of the **Mechanics of Solids**. A **Solid Body** such as a lump of iron or a lump of wood has a definite **Volume**. It also has a definite **Shape**. If force be applied to it, both the shape and the volume are generally changed, though the change in many cases is very small. The force required to produce a given change of shape or size differs for different substances.

Great force must be applied to a lump of iron to produce an appreciable alteration in shape or volume; a solid india-rubber ball can be squeezed from its spherical form by a much smaller force than is necessary in order to change to an equal extent the shape of a similar sphere of iron.

Again, if the force applied be not too large, both the iron and the india-rubber will regain their original shape and volume when it is removed. Iron and india-rubber are both **Elastic Substances**.

DEFINITION. *An Elastic Substance is one which has a definite shape and volume when free from the action of external forces; when such forces are applied, the shape, or the volume, or both are changed; when the forces are removed—provided they have not been too great—the substance recovers its shape and its volume.*

If the forces are too great the body may be strained beyond recovery, the limits of its elasticity may be passed; when the forces are removed the body does not regain its former shape and volume.

A solid body then can offer resistance (*a*) to forces tending to change its volume, (*b*) to forces tending to change its shape. In consequence of the former it is said to have **Volume Elasticity**; in consequence of the latter it is said to have **Elasticity of Form** or, as it is called, **Rigidity**.

A perfectly rigid body is one in which no change of shape is produced by the action of a finite force; no known body is perfectly rigid, though the rigidity of most solids is so great that for many purposes we may treat it as perfect.

Solids possess these two kinds of elasticity in very different degrees. Thus the shape of a piece of india-rubber is easily altered; experiment however shews that it requires considerable force to change its volume. A piece of cork can by the application of moderate force be squeezed into a much smaller volume; its shape however is not necessarily greatly changed in the process. In comparison with its volume elasticity the rigidity of cork is considerable.

Any body which has Elasticity of Form or Rigidity is called a Solid. In consequence of its rigidity the body preserves its shape.

It is a matter of everyday experience that there are numbers of bodies which exhibit little or no tendency to retain their shape. Ice is a solid, on melting it becomes water, the particles of the water slide freely over each other and the shape assumed depends on that of the vessel in which it is contained. Water, alcohol and numerous other substances can be poured from one vessel to another. Such substances have practically no rigidity; they offer practically no resistance to forces tending to produce sliding motion of their particles and thus to change their shape. They are called **Fluids**. We distinguish then between **Solids** and **Fluids** thus.

DEFINITIONS. *A Solid is a body which can offer permanent resistance to forces tending to change its shape.*

A Fluid is a body which can offer no permanent resistance to forces tending to change its shape.

In other words, a Solid has rigidity, a Fluid¹ has no rigidity.

2. Fluids. Water and alcohol have been instanced as examples of fluid bodies, we can readily pour them from one vessel to another, and these fluids adapt themselves almost instantaneously to the shape of the vessel into which they are poured; they offer practically no resistance to forces tending to change their shape; moreover the change of shape follows very rapidly on the application of the slightest force.

There are other substances, however, in the case of which, time is necessary, before a change of shape will occur under the action of a force. Honey or treacle can be poured from one vessel to another, but they pour slowly. We can make a heap of treacle in the middle of a dish or plate, but on leaving it, the heap is gradually flattened out and the plate covered. The treacle has no permanent rigidity, it can offer no resistance to a small force, such as its weight, if that force acts for a sufficient time; treacle like water is a fluid, but it has the property of **Viscosity** and in consequence yields slowly to forces tending to change its shape. A **Perfect Fluid** is one which yields instantaneously to such forces. No fluid in nature is perfect, water and alcohol have some slight viscosity, but the amount is so slight that they may be treated as perfect in comparison with fluids such as treacle, honey or glycerine, which are called **Viscous Fluids**.

It is sometimes difficult to draw the line between a solid and a fluid or between a viscous fluid and one which is practically perfect.

Thus consider a stiff jelly made by melting gelatine in water and allowing it to solidify; the jelly retains its shape when cold and recovers it again after being slightly squeezed, it is a solid—on mixing it with more water we obtain a sticky, viscous liquid, if the quantity of water be considerably increased the viscosity can be made very small indeed and the fluid is practically perfect.

¹ It will not however be sufficient to give this last statement as a definition of a fluid unless at the same time a definition of rigidity be given.

Again, a piece of pitch or of cobblers' wax has a definite shape, but it can only retain it for a short time, if placed on a flat surface it will gradually flow over the whole; pitch then must be classed as a fluid, but as a very viscous one. We may shew this by placing some pitch in a wide-necked funnel and leaving it in a fairly warm place, the pitch will gradually flow through the funnel. The same fact is illustrated by supporting a rod of sealing-wax at two points near its ends respectively, in time the rod is seen to bend, sinking in the middle; a small force produces change of shape but time is necessary in order that the effect may take place.

We must also distinguish between viscous fluids and plastic solids. Beeswax and paraffin wax are both solids, they have a definite shape and will retain it indefinitely, the application of quite a small force however is sufficient to mould a piece of beeswax into a new form; the rigidity of such a substance is extremely small, the limits within which it will recover its form are very narrow; it is said to be Plastic. If a paraffin candle be substituted for the sealing-wax in the experiment just described, it will not sag as the wax did, it can support its weight without continuous yielding and does not gradually change in shape under so small a force. The paraffin is a soft solid.

We thus see the importance of the word *permanent* in the above definition of a fluid. In the experiments to be described it will generally be assumed that the fluids employed are not viscous, though we shall find that in dealing with the equilibrium of fluids—**Hydrostatics**—we need not consider viscosity. See Section 15.

3. Liquids and Gases.

Fluids then differ from Solids in that they have *no Rigidity*, they have however **Volume Elasticity**. A fluid, like a solid, will resist a force tending to reduce its volume, and will recover that volume when the force is withdrawn.

But Fluids can be divided into two main classes possessing this property in very different degrees.

Water and air are both fluids; very great force is needed to produce even a small change in the volume of a mass of water, that of a mass of air (Section 79) can be changed easily.

Some fluids are practically **Incompressible**, the change of volume produced by the application of even a very large force is extremely small. Such fluids are called **Liquids**.

Water, Oil, Alcohol, Vinegar are liquids. Other fluids are very easily compressible; these are called Gases. Such are Air, Oxygen, Hydrogen, Carbonic Acid.

DEFINITIONS. *A Liquid is a substance which can offer no permanent resistance to forces tending to change its shape, but which offers very great resistance to forces tending to diminish its volume.*

A Gas is a substance which can offer no permanent resistance to forces tending to change its shape, and which offers only a small resistance to forces tending to diminish its volume.

To illustrate the difference between a Liquid and a Gas let us imagine a cylinder closed with a tightly-fitting piston and suppose the area of the piston to be 100 square centimetres. Let there be a litre (1000 c. cm.) of water in the cylinder, then the depth of the water will be 10 cm.

Now suppose a weight of 100 kilogrammes is placed on the piston so that each square centimetre of the piston has to carry an additional weight of 1 kilogramme, then it has been shewn that—supposing the piston to move without friction—it would sink by about one two-thousandth ($\frac{1}{2000}$) of a centimetre; the change of volume of the whole litre produced by this pressure would be $\frac{1}{200}$ of a cubic centimetre, the change in each cubic centimetre therefore would be $\frac{1}{20000}$ of a cubic centimetre.

Thus the volume of a given mass of a liquid is very nearly constant and is only changed very slightly by the application of considerable forces. We may treat a liquid as a fluid of invariable density. See Section 5.

Now let us suppose that the water is removed from the cylinder and replaced by an equal volume of air at atmospheric pressure¹. Then, on repeating the experiment, it would be found that the piston—if it were perfectly frictionless—would sink about five centimetres, the volume of the air would be about halved. Each cubic centimetre would now occupy half a cubic centimetre. Air at atmospheric pressure is about 10,000 times as compressible as water.

¹ See Section 67.

The density of the air is hereby doubled. Gases then are fluids the density of which depends on the pressure to which they are subjected.

The experiment could not be carried out in this simple form because of the friction of the piston against the sides of the cylinder, but this difficulty can be avoided by means of a suitable modification of the apparatus. See Section 79.

4. Free Surface of Liquids.

There is moreover another distinction between a liquid and a gas. Imagine that the walls of the cylinder just described are continued some distance above the piston, on raising the piston the level of the upper surface of the water still remains at about 10 centimetres from the bottom, above it there will be an almost empty space containing a little water vapour; the water will have a free surface separating it from the empty space above.

If, however, the cylinder contain a gas this will no longer be the case, the gas will expand as the piston rises, the whole space below the piston will be occupied by the gas, its density and the pressure it exerts on the sides of the cylinder will diminish; there will be no free surface.

Thus we may say that an incompressible fluid—a **Liquid**—is a substance which can offer no permanent resistance to forces tending to change its shape, but which has a definite density; it will therefore not increase indefinitely in volume if the force on its surface be diminished; when placed in any vessel it will occupy the lower portion of the vessel completely and will have a free surface.

A **Gas** is a substance which can offer no permanent resistance to forces tending to change its shape; its density however depends on the forces impressed on its surface, it will increase indefinitely in volume if these forces be sufficiently diminished, and, if placed in an empty closed vessel of any size, will fill it completely and have no free surface.

For the purposes of this book we may treat liquids as incompressible.

5. Density. Equal volumes of different substances differ in mass and therefore also in weight. We have already (*Dynamics*, Section 12) given a definition of the term **Density** which has been used in the last Section, and deduced some results from it.

The definition is as follows :

DEFINITION. *The Density of any homogeneous substance is the mass of unit volume of that substance.*

It follows from this definition that to determine the density of a body we must find the number of units of mass in the unit of volume, we require therefore to know the unit of mass and the unit of volume ; if these be the gramme and the cubic centimetre respectively we may say that the density is so many grammes per cubic centimetre. Thus in these units the density of water is 1 gramme per c.cm., that of iron 7.76 grammes per c.cm. In any other units the numerical measures of the densities of these substances would generally be different. Thus a cubic foot of water contains 998.8 oz. or 62.321 lbs. ; hence the density of water is 998.8 oz. per cubic foot or 62.321 lbs. per cubic foot ; iron is 7.76 times as dense as water, hence its density is 7.76×62.321 lbs. per cubic foot.

From the above definition of density we can find a relation between the Mass, Volume, and Density of a body.

PROPOSITION 1. *To shew that if the mass of a homogeneous body be M grammes, its density ρ grammes per cubic centimetre and its volume V cubic centimetres, then $M = V\rho$.*

For by the definition,

the mass of 1 c.cm. = ρ grammes,
 therefore the mass of 2 c.cm. = 2ρ grammes,
 the mass of 3 c.cm. = 3ρ grammes,
 hence the mass of V c.cm. = $V\rho$ grammes.

Therefore $M = V\rho$.

We may write this as

$$\rho = \frac{M}{V},$$

and thus we have the result that the density of a homogeneous substance is the ratio of its mass to its volume.

A result similar to the above holds for any other consistent system of units.

To determine then the density of a piece of homogeneous material we require to know its mass, which is obtained in terms of a standard mass by weighing (*Statics*, Sections 59, 60), and its volume, which may be found in some cases by direct measurement, in others by the displacement method (*Dynamics*, Experiment 4), in others again by one or other of the methods described in the following pages, Experiments 15 etc. In any case we should notice that the measure of the density will depend on the units adopted for the measurement of the mass and the volume; these units must be known in order to determine the density completely.

6. Specific Gravity. In many cases, however, we are only concerned with the relative masses or the relative weights of equal volumes of two substances; it may be sufficient for us to know that a lump of iron is 7.76 times as heavy as an equal volume of water, or that the weight of a piece of pine wood is about .56 of that of an equal volume of water.

DEFINITION. *The Specific Gravity of a substance is a number which expresses the ratio between the weight of the substance and that of an equal volume of some standard substance, usually water.*

Thus, if W be the weight of this substance, W' the weight of an equal volume of some standard substance, and σ the specific gravity, then we have

$$\sigma = \frac{W}{W'}.$$

We notice in the first place that the specific gravity of a body, being the ratio of two weights, is a number and does not depend on the units in which the weights are expressed, so long of course as those units are the same for the two. The specific gravity merely expresses the number of times which the weight of a certain volume of some standard is contained in

the weight of an equal volume of the substance. A cubic inch of iron is 7.76 times as heavy as a cubic inch of water whether it be measured in grammes weight, in pounds weight or in any other units.

We can also find a relation between the weight, the volume and the specific gravity of a substance thus.

PROPOSITION 2. *To shew that if the weight of a homogeneous body be W , its volume V , and its specific gravity σ , then $W = V\sigma\omega$, where ω represents the weight of unit of volume of the standard substance.*

Let W' be the weight of an equal volume V of the standard substance, then, since ω is the weight of each unit of volume of the standard, the weight of V units of volume is $V\omega$.

Hence W' is equal to $V\omega$.

$$\text{But} \quad \sigma = \frac{W}{W'} = \frac{W}{V\omega}.$$

$$\text{Therefore} \quad W = V\sigma\omega.$$

Thus if we know the volume of a body, its specific gravity referred to some standard substance, and the weight of unit of volume of that standard, we can calculate the weight of the body.

The calculation is simplified if we take water as the standard substance, the volume of 1 cubic centimetre as the unit of volume and the weight of 1 gramme as the unit of weight, for, since the weight of 1 cubic centimetre of water is 1 gramme weight, we have in this case the weight of the unit of volume as the unit of weight; thus

$$\omega \text{ is unity and } W = V\sigma.$$

Hence, *The weight of a body in grammes weight is found by multiplying its specific gravity by its volume in cubic centimetres.*

This same simple relation does not in general hold for other systems of units; thus if the weight of a pound be the unit of weight and one cubic foot the unit of volume, since a cubic foot of water has 62.321 pounds weight, the value of ω is 62.321 pounds weight, so that in order to find the weight of a body in pounds weight we multiply its specific gravity by its volume in cubic feet and by 62.321.

7. Definitions of Specific Gravity.

We can put the definition of specific gravity into various other forms which may be useful.

Thus, let W be the weight of a body, M its mass, V its volume and ρ its density.

Let σ be its specific gravity referred to some standard substance; consider an equal volume V of this standard, let W' be its weight, M' its mass and ρ' its density.

$$\begin{aligned} \text{Then we have} \quad W &= Mg = \rho Vg, \\ W' &= M'g = \rho' Vg. \end{aligned}$$

$$\text{Hence} \quad \sigma = \frac{W}{W'} = \frac{Mg}{M'g} = \frac{M}{M'}.$$

Thus, *The specific gravity of a body is the ratio of the mass of the body to the mass of an equal volume of some standard substance.*

$$\begin{aligned} \text{Again, since} \quad M &= \rho V, \quad M' = \rho' V, \\ \text{we have} \quad \sigma &= \frac{W}{W'} = \frac{M}{M'} = \frac{\rho V}{\rho' V} = \frac{\rho}{\rho'}. \end{aligned}$$

Thus, *The specific gravity of a body is the ratio of its density to the density of the standard substance.*

Specific gravity is therefore sometimes spoken of as relative density.

$$\text{Again, since } \sigma = \rho/\rho', \text{ we have } \rho = \sigma\rho'.$$

Thus, *We can find the density of a body by multiplying its specific gravity by the density of the standard substance.*

Now, on the c.g.s. system, the density of water is 1 gramme per cubic centimetre, the value of ρ' then is 1 gramme per cubic centimetre, and

$$\rho = \sigma \text{ grammes per cubic centimetre.}$$

Thus, *On the c.g.s. system the numbers expressing the density and the specific gravity of a body are the same.*

It does not, of course, follow that the density and the specific gravity are the same, and the distinction between them must be carefully borne in mind.

8. The Standard Substance.

When determining the specific gravities of solids and liquids water is usually adopted as the standard. It is suitable for the purpose for it can readily be obtained in a state of purity.

The density of water like that of other substances depends on the temperature; thus the mass of a given volume of water is not always the same. Water above 4° C. expands as the temperature is raised; thus a volume of 1 cubic centimetre will weigh less when warm than it does when cold. In order to be quite accurate it is necessary to specify the temperature of the standard substance; for water this temperature is taken at 4° C., for at this temperature it is found (see Glazebrook, *Heat*, §§ 88—90) that water is denser than at any other. A given volume will weigh more at 4° C. than at any other temperature.

The variation of density, however, due to change of temperature is very small and for the purposes of this book need not be taken into account; we shall assume therefore as the weight of 1 cubic centimetre of water 1 gramme weight and as the weight of 1 cubic foot of water 62.321 pounds weight at any temperature.

The densities of gases are excessively small when compared with those of most solids and liquids. Thus the density of hydrogen at 0° C. and 760 mm. of pressure is .0000896 grammes per c.cm., that of oxygen is sixteen times as great; hence, if water were taken as the standard substance in experiments on gases, the values of the specific gravities would all be small fractions; to avoid this it is usual to adopt hydrogen at a standard pressure and temperature as the standard substance.

9. Measurement of Specific Gravity.

To determine the specific gravity of a body we need to find its weight and the weight of an equal volume of some standard substance—water. In some cases this can be done directly, some experiments illustrating this are given below; in most cases, however, the methods described in Chapter VI. must be followed.

EXPERIMENT 1. *To determine directly the specific gravities of various substances.*

Make a number of cubes of the various substances wood, lead, iron, brass, copper, etc., all of the same size. Make a cubical box of some material such as brass into which the cubes will exactly fit. Weigh each of the cubes carefully and let the weights be W_1 , W_2 , etc.; weigh the box empty, then fill it with water and weigh again, the difference gives the weight of water filling the box, let it be W' ; the volume of this weight of water is equal to that of each of the cubes. Divide the weights W_1 , W_2 , etc. by W' , the respective quotients will give the specific gravities required.

The numbers thus found will also give the densities of the cubes in grammes per cubic centimetre. These however may be determined directly thus.

EXPERIMENT 2. *To determine the density of a cubical block.*

Determine by the balance the mass of the block in grammes. Measure with the calipers or the screw gauge (*Dynamics*, Section 7) the length of an edge and by cubing this find the volume in cubic centimetres.

Divide the mass in grammes by the volume in cubic centimetres, the quotient is the density in grammes per c.cm. Since the block may not be quite cubical it is best, in order to determine the volume, to measure the length of each of the three edges which meet at one angular point and multiply these three together.

EXPERIMENT 3. *To verify that the mass of 1 cubic centimetre of water is 1 gramme.*

Obtain a hollow vessel the volume of which can be found by measurement; for this purpose a hollow cylindrical vessel is convenient. Measure with the caliper-compasses or otherwise the interior diameter of the cylinder in centimetres, and, dividing this by 2, find the radius, r centimetres. Measure also the depth, d centimetres, of the cylinder. Then the area of the bottom is πr^2 square centimetres and the volume of the cylinder is $\pi r^2 d$ cubic centimetres. Weigh the cylinder empty, fill it with water and weigh again and thus obtain the mass of water filling the cylinder: let it be W grammes.

Then it will be found that

$$W = \pi r^2 d.$$

Hence the mass in grammes is numerically equal to the volume in cubic centimetres, thus the mass of 1 cubic centimetre of water is 1 gramme.

Instead of weighing the cylindrical vessel and its contents it may be more convenient to weigh the water in a small flask or bottle. Pour from the flask sufficient water to fill the cylinder and then weigh again, the difference will give the mass of water required to fill the cylinder.

EXPERIMENT 4. *To determine the specific gravity of a fluid.*

Obtain a flask or bottle with a narrow neck—one holding about 50 c.cm. will be suitable—make a scratch on the neck with a fine file. Weigh the flask empty, let its weight be W , fill it with water up to the scratch, dry the outside and weigh again. Let the weight be W_1 . We thus obtain the weight $W_1 - W$ of a volume of water filling the flask up to the mark. Empty the water and fill the flask up to the mark with the liquid to be examined. Weigh again, let the weight be W_2 . Then the weight of liquid which fills the flask to the mark is $W_2 - W$, and the weight of an equal volume of water is $W_1 - W$.

Thus the specific gravity¹ of the liquid is given by

$$\sigma = \frac{W_2 - W}{W_1 - W}.$$

There are numerous other methods of finding specific gravity. An account of these and of the precautions required in the use of the specific gravity bottle will be given in Chapter VI.

The following examples illustrate this part of the subject.

Examples. (1) *A sphere 10 cm. in radius has a mass of 5 kilogrammes, find its density.*

The volume of a sphere of radius r is $\frac{4}{3}\pi r^3$.

Thus the volume of the given sphere is

$$\frac{4}{3} \cdot \frac{22}{7} \cdot 1000 \text{ c.c.}$$

¹ This method is usually known as that of the specific gravity bottle. For further details see Section 61.

Its mass is 5×1000 grammes.

Hence its density is

$$\frac{5.3.7}{4.22} \text{ grammes per c. cm.,}$$

and this reduces to 1.194 grammes per c. cm.

(2) *The specific gravity of iron is 7.76, find the weight of 1000 cubic feet of iron.*

The weight of 1 cubic foot of water is 62.32 lbs. weight.

Thus the weight of 1000 cubic feet of water is 62321 lbs. weight, and that of 1000 cubic feet of iron is

$$62321 \times 7.76,$$

or 483611 lbs. weight.

(3) *The specific gravity of glass is 2.5. What volume of glass weighs 1 cwt.?*

A cubic foot of water weighs 62.321 lbs. weight.

Thus the volume of 1 lb. weight of water is $1/62.321$ c. feet and the volume of 1 cwt. or 112 lbs. is $112/62.32$ c. feet.

Now a given volume of glass is 2.5 times as heavy as the same volume of water.

Hence the volume of a given mass of glass is $1/2.5$ of that of an equal mass of water.

Thus the volume of 1 cwt. of glass is

$$\frac{112}{2.5 \times 62.32} \text{ c. feet,}$$

and this reduces to .7189 c. feet.

(4) *The mass of 5 cubic feet of ebony is 365 lbs., find its density in grammes per cubic centimetre.*

The density of ebony in lbs. per cubic foot is $365/5$ or 73.

Now 1 lb. contains 453.6 grammes, 1 c. foot contains 28315 c. cm.

Thus the mass of 28315 c. cm. of ebony is 73×453.6 grammes.

Hence the density is

$$\frac{73 \times 453.6}{28315},$$

or 1.168 grammes per c. cm.

10. Values of Specific Gravities.

The following is a Table of Specific Gravities of some few substances.

SOLIDS.

Aluminium	2·7	Iron	7·76
Amber	1·1	Lead	11·4
Beech wood	·69—·8	Marble	2·7
Brass	8	Oak wood	·74
Bronze coinage	8·66	Pine wood	·56
Copper	8·95	Silver	10·57
Cork	·24	Slate	2·1
Diamond	3·5	Zinc	7·2
Gold	19·3	Wax (bees)	·96
Glass	2·5—3·6	Ice	·918.
Tin	7·29		

LIQUIDS.

Alcohol	·795	Nitric acid	1·50
Carbon disulphide	1·28	Mercury	13·6
Chloroform	1·53	Olive oil	·915
Glycerine	1·26	Petroleum	·84—·878
Sulphuric acid	1·85	Sea water	1·026.

***11. Propositions on Density and Specific Gravity.**

There are two other Propositions connected with this part of the subject which may be useful.

**PROPOSITION 3. To find the mass and the density of a mixture of any number of substances whose volumes and densities are known.*

Let $V_1, V_2, \text{ etc.}$, be the volumes of the substances, $\rho_1, \rho_2, \text{ etc.}$ their densities. Let us suppose that there is no chemical action between the substances on mixing, then the volume of the mixture is the sum of the volumes of the component parts. Let it be V and let ρ be the density of the mixture which we suppose to be homogeneous.

Then, since the volume is unchanged by mixing,

$$V = V_1 + V_2 + V_3 + \text{etc.},$$

and since the mass of the mixture is the sum of the masses of its components,

$$V\rho = V_1\rho_1 + V_2\rho_2 + V_3\rho_3 + \text{etc.}$$

Thus
$$\rho = \frac{V_1\rho_1 + V_2\rho_2 + \dots}{V_1 + V_2 + \dots}.$$

If the volume change on mixing and become V' the first relation above given will not be true, but we shall have

$$V'\rho = V_1\rho_1 + V_2\rho_2 + V_3\rho_3 + \dots$$

We can establish a similar formula, using specific gravity and weight instead of density and mass.

Thus if $\sigma_1, \sigma_2, \dots$ be the specific gravities and ω the weight of a unit of volume of the standard substance, we have, assuming no chemical action to occur,

$$V = V_1 + V_2 + \dots + \text{etc.}$$

$$\begin{aligned} V\sigma\omega &= \text{weight of whole} = \text{sum of weights of components} \\ &= V_1\sigma_1\omega + V_2\sigma_2\omega + \dots \end{aligned}$$

Thus, dividing by ω ,

$$V\sigma = V_1\sigma_1 + V_2\sigma_2 + \dots + \text{etc.}$$

***PROPOSITION 4.** *To find the volume and density of a mixture of substances whose masses and densities are known.*

Let the masses be M_1, M_2 , etc. and the densities ρ_1, ρ_2 , etc. Let M be the mass of the mixture, ρ its density.

Then the volumes of the separate substances are respectively $M_1/\rho_1, M_2/\rho_2, \dots$ and the volume of the mixture is M/ρ .

Thus we have

$$\begin{aligned} M &= M_1 + M_2 + M_3 + \dots \text{ etc.} \\ \frac{M}{\rho} &= \frac{M_1}{\rho_1} + \frac{M_2}{\rho_2} + \frac{M_3}{\rho_3} + \dots \text{ etc.} \end{aligned}$$

Hence

$$\rho = \frac{M_1 + M_2 + \dots \text{ etc.}}{\frac{M_1}{\rho_1} + \frac{M_2}{\rho_2} + \dots \text{ etc.}}$$

A similar formula connects together the weight and specific gravity of a mixture, for we have, if W_1, W_2, \dots etc. be the weights, $\sigma_1, \sigma_2, \dots$ etc. the specific gravities of its components,

$$\begin{aligned} W &= W_1 + W_2 + W_3 + \dots + \text{etc.}, \\ \frac{W}{\sigma\omega} &= \frac{W_1}{\sigma_1\omega} + \frac{W_2}{\sigma_2\omega} + \frac{W_3}{\sigma_3\omega} + \dots + \text{etc.} \end{aligned}$$

Examples. (1) *If a volume of 10 c.cm. of a liquid of density .8 grammes per c.cm. be mixed with 15 c.cm. of a liquid of density .7 grammes per c.cm., find the density of the mixture.*

The volume of the mixture is $10 + 15$ or 25 cubic centimetres.

The mass of the mixture is $10 \times .8 + 15 \times .7$ or 18.5 grammes.

Hence its density is $18.5/25$ or .74 grammes per c.cm.

(2) *An alloy of zinc (sp. gr. 7.2) and copper (sp. gr. 8.95) has a mass of 467 grammes. Its volume is 60 c.cm. Find the volume of each component.*

Let v_1 c.cm. be the volume of the zinc and v_2 c.cm. that of the copper.

Then the mass of the zinc is $7.2 \times v_1$ grammes, that of the copper is $8.95 \times v_2$ grammes. The sum of these two is the total mass 467 grammes, the sum of the two volumes is the total volume 60 cubic centimetres.

$$\begin{aligned} \text{Thus} \quad v_1 + v_2 &= 60, \\ 7.2 v_1 + 8.95 v_2 &= 467. \end{aligned}$$

Hence, solving these equations,

$$\begin{aligned} 1.75 v_1 &= 537 - 467 = 70, \\ 1.75 v_2 &= 467 - 432 = 35. \end{aligned}$$

$$\begin{aligned} \text{Thus} \quad v_1 &= 40 \text{ c.cm.} \\ v_2 &= 20 \text{ c.cm.} \end{aligned}$$

(3) *A mixture is made of 14 cubic centimetres of sulphuric acid (specific gravity 1.85) and 6 cubic centimetres of water. The specific gravity of the mixture is found to be 1.615. Determine the amount of contraction which has taken place.*

If there were no contraction the volume of the mixture would be $14 + 6$ or 20 c.cm.; let the actual volume be V c.cm. Then, since the density is 1.615 grammes per c.cm., the mass is $V \times 1.615$ grammes.

The masses of the components are 14×1.85 or 25.9 grammes and 6 grammes respectively.

The mass of the mixture is the sum of the masses of its components.

$$\text{Hence} \quad V \times 1.615 = 25.9 + 6 = 31.9.$$

$$\text{Therefore} \quad V = 19.75 \text{ c.cm.}$$

Hence the contraction required is $20 - 19.75$ or .25 c.cm.

EXAMPLES.

1. What is meant by the density of a substance?

How would you find the density of water?

2. The density of a substance being defined as the mass of a unit of volume of the substance, shew precisely how the density of a liquid may be experimentally determined.

3. Describe the experiments you would make in order to determine the mass of a cubic centimetre of water.

4. Explain clearly the distinction between specific gravity and density and shew how the numerical value of these quantities depends on the choice of fundamental units.

5. Find the density and specific gravity of the following body:

A rectangular pillar having a square base each side of which is one foot in length, the height of the pillar being 10 feet and its weight half a ton.

(The weight of a cubic foot of water may be taken as 1000 ounces.)

6. The density of copper is 8.95 grammes per c.cm. The diameter of a piece of copper wire is 1.25 mm. and its length 1025 cm.; find its mass.

7. Find the density of a cylinder 1 foot in height and 6 inches in radius whose mass is 60 lbs.

8. Find the density of a sphere 10 cm. in radius and 5 kilogrammes in mass.

9. Determine the density of the cylinder described in Question 7 in grammes per c.cm.

10. Find the density of a pyramid on a triangular base each side of which is 10 cm. and which has an altitude of 30 cm., the mass of the pyramid being 8 kilogrammes.

11. The density of mercury is 13.59 grammes per c.cm.; find it in grains per cubic inch.

12. Compare the densities of a sphere 5 cm. in radius, 5 kilos. in mass, and of a cylinder 1 foot in height, 6 inches in radius and 60 lbs. in mass.

13. Find the mass in lbs. of a cube of gold each side of which is 4 inches.

14. An iceberg is 30 fathoms high, 40 fathoms wide and 80 fathoms thick; find its mass in tons.

15. A carboy of sulphuric acid has a mass of 98 kilogrammes; find its volume.

16. It is desired to float a piece of slate a metre square by 5 centimetres thick by means of cork floats. What volume of cork is required?

17. Find the specific gravity of a mixture of glycerine and alcohol (i) in equal parts by weight, (ii) in equal parts by volume.

18. A piece of brass is made from 2 lbs. of copper and 3 lbs. of zinc, the volume of the copper being 6 cubic inches, and that of the zinc $13\frac{1}{2}$ cubic inches; find the specific gravity of the brass.

~~19.~~ A cylindrical tube, 16 cms. long, holds when full 1 gramme of mercury, sp. gr. 13.6; find the sectional area of the tube.

20. The specific gravity of a faulty iron casting which weighs 3 lbs. is found to be 5.8. If the normal specific gravity of cast iron be 7.2; find what volume of the faulty iron is unoccupied by iron.

(A cubic inch of water weighs 0.57 oz.)

*21. If the specific gravity of a mixture of glycerine and water be 1.094, find the relative weights of glycerine and water in the mixture, the specific gravity of pure glycerine being 1.26.

22. The mass of a piece of brass is 25 grammes and the density of brass is 8.4 grammes per c.cm., find the volume of the brass.

CHAPTER II.

FLUID PRESSURE.

12. General considerations on Stress.

Consider a block of wood lying on a smooth horizontal table, let a weight be placed on the wood, as in Fig. 1. The wood is in equilibrium, the downward force exerted by the weight is balanced by the upward force between the table and the wood. Imagine the block divided into two parts by a horizontal plane CD , the upper part is acted on by the weight which presses it downwards; since there is equilibrium the weight must be balanced by a force exerted upwards by the lower part of

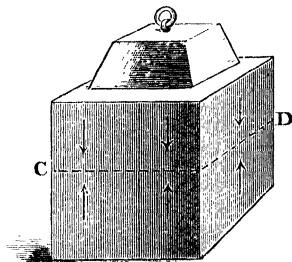

Fig. 1.

the block on the upper; if now we consider the lower part of the block a downward force is exerted on its upper surface equal to the upward force which this surface exerts on the upper portion. This downward force is balanced by the upward force exerted by the table; the two portions of the block are squeezed together across the section CD ; the block is said to be under **Stress**. The two equal forces acting in opposite directions on the two portions of the block across the

section CD constitute a **Stress**. In the case considered the forces are at right angles to the surfaces on which they act; the external forces, the weight and the pressure of the table, are such as to bring the two portions of the body, separated by the plane CD , more close together than they could otherwise be; each portion of the body "thrusts" or pushes the other. We speak of the force which each part of the body exerts on the other across the plane CD as a normal Thrust or more simply as a "**Thrust**."

13. Thrust and Tension.

The Stress which we have just been considering consists of a simple Thrust acting in opposite directions on the two sides of any horizontal plane such as CD , by which we imagine the body to be divided.

It should of course be noticed that the division is imaginary, the two parts of the body on either side of any horizontal plane thus act on each other; it is not necessary actually to cut or divide the body to give rise to the action.

There are, of course, many other ways in which we can apply a simple thrust to a surface; thus when we push a body with a long pole, directing the push along the axis of the pole, any section of the pole at right angles to the axis is subject to a Thrust, the portion of the pole on one side of the section thrusts and is thrust by that on the other, the stress across the section is a simple thrust.

But now suppose one end of the pole is attached to some body and that we pull at the other; if we now consider a section of the pole at right angles to its length, the portion of the pole on one side of the section is pulled by that on the other; the pole throughout its length is subject to a **Pull or Tension** instead of a Thrust.

The Stress across each section at right angles to the length is a simple **Tension** acting along the pole.

In both these cases however the stress is at right angles to the surface to which it is applied.

14. Shearing Stress.

Let us return now to the block of wood on the table and imagine it divided, as in Fig. 2, by a plane CD inclined to the horizon. The upper part is acted on by the weight which presses it vertically down; since there is equilibrium this vertical force must be balanced by the force which the lower part of the block exerts on the upper, this latter force then must be vertical. But the plane CD is inclined to the horizon, hence in this case the force which the lower portion of the block exerts on the upper is inclined to the plane across which it

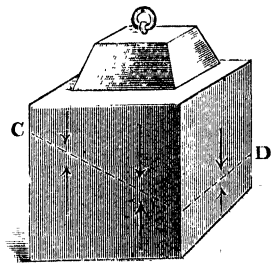

Fig. 2.

acts. The force therefore may be resolved into two components, one, at right angles to the plane, constituting a normal thrust on the upper part, the other, parallel to the plane, preventing the upper part from slipping down; this second component constitutes a "**Shearing Force.**" It is balanced by the equal and opposite shearing force exerted on the portion of the block below the plane CD and these two forces constitute a **Shearing Stress**. The components of the stress across the plane CD are a normal thrust which tends to compress the solid into a smaller space and a shearing stress tending to make it slide parallel to the plane CD and thus to change its shape.

15. Stress in Solids and Fluids.

Hence, if we imagine any plane drawn in a solid body, the Stress across the plane due to the action which the portion of the solid on one side of the plane exerts on that on the other may be either a **Thrust**, a **Tension** or a **Shearing Stress**.

In consequence of its **Rigidity** a solid can withstand shearing stress, it yields slightly until the impressed force is

just balanced by the elastic forces called into play by the yielding and then retains its new form so long as the force is impressed.

A fluid however cannot permanently withstand shearing stress.

Consider a solid body ABC , Fig. 3, resting on a table and let DE be a plane inclined to the horizon, dividing the body

into two parts. Then the weight of the portion DBE is balanced by the force across this plane. If this force were a normal thrust perpendicular to DE the portion DBE would slide down, its weight has a component parallel to the plane; this component however is balanced by the shearing force exerted across the plane.

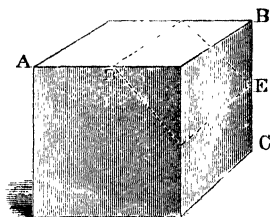

Fig. 3.

Now, suppose the portion DBE to become fluid; it runs

away, the fluid has no rigidity and in consequence can exert no shearing force across any plane, there is therefore no force to balance the component of the weight parallel to DE , and equilibrium can no longer be maintained; the fluid yields to the impressed shearing force.

We have thus arrived at the following results. If we imagine a body to be divided into two parts, each part exerts a force on the other across the dividing surface.

These two forces are equal and opposite and are spoken of together as a **Stress**.

In general the forces can be resolved into components respectively at right angles to, and parallel to the surface across which they act.

And we can state the following Definitions.

DEFINITION. *The components of a Stress at right angles to the surface to which it is applied constitute a Thrust or a*

Tension. *The components parallel to the surface constitute a Shearing Stress.*

A Solid is a body which offers permanent resistance to any form of stress, so long at least as the stress is not too great.

If the stress be too great the solid may yield or break.

A Fluid is a body which offers no permanent resistance to continued shearing stress, however small.

It follows from this that any shearing stress, however small, will *in time* produce motion in a fluid—if the fluid be very viscous it will be a long time before flow takes place under a small shearing stress; if, on the other hand, the viscosity be small, flow follows rapidly. If there were no viscosity no shearing stress could ever be exerted whether the fluid were at rest or in motion.

DEFINITION. *A Perfect Fluid is a body which, whether at rest or in motion, can never offer resistance to a shearing stress, however small.*

There are no fluids known which satisfy this definition.

When however a fluid is in equilibrium, whether it be viscous or not, there can be no shearing stress, for since a fluid can offer no *permanent* resistance to shearing stress even a small shear, if it existed, would in time disturb the equilibrium. We thus arrive at the result, that *In any fluid in equilibrium there is no shearing stress.*

16. Fundamental Property of a Fluid.

The following Proposition then expresses the Fundamental Property of a fluid.

PROPOSITION 5. *To prove that, when a fluid is in equilibrium, the force, which it exerts on any surface with which it is in contact, is at right angles to that surface.*

For, let ACB , Fig. 4, be a portion of the surface and, if it

be possible, let the force P which the fluid exerts on a small portion of the surface near C be inclined to it in the direction DC . Then the force which the surface exerts on the fluid is P , acting in direction CD . This force can be resolved into a force R at right angles to the surface, constituting a normal thrust on the fluid, and a tangential

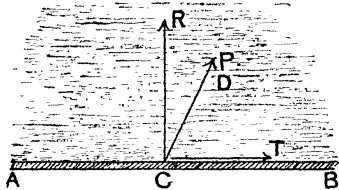

Fig. 4.

force T parallel to the surface. This constitutes a shearing force and tends to make the fluid particles slide over the surface; since the fluid has no rigidity it cannot resist this force and motion will take place, which is contrary to the supposition that the fluid is at rest. Hence there can be no tangential force such as T , therefore the whole force is R , at right angles to the surface.

Thus the force exerted by a fluid on any surface with which it may be in contact, or by one portion of a fluid on any other portion, across any surface separating the two, is a normal thrust at right angles to the surface.

Experiments have shewn that it is possible for a fluid under certain circumstances to sustain a tension or pull; these circumstances however occur very rarely, for our present purposes we may suppose that the only stress which can exist in a fluid is a thrust.

17. Stress distributed over a Surface.

Imagine now that we have a piece of a stiff board resting on a table; on placing weights on the upper side of the board, force is exerted on the table, and this is balanced by the force¹ which the table exerts on the weights. Suppose the board is divided into a number of squares each 1 centimetre in edge and therefore 1 square centimetre in area; there is in general a force between each of these squares and the table, though the forces acting on each of the squares need not be equal. Suppose, however, that the same weight, 50 grammes say, is placed

¹ Part of this force is due to the weight of the board, we suppose this to be small compared with the weights it carries and neglect its effect.

on each square; then the upward force on each square will be 50 grammes weight; the resultant upward force will be found by multiplying by 50 the number of square centimetres contained in the area of the board.

The force in this case is **Uniformly Distributed** over the surface, and the thrust or resultant upward force is found by multiplying the force per unit area of the surface by the number of square centimetres in the area.

DEFINITION. *The Thrust on a surface is said to be Uniformly Distributed over the surface when it is the same on every equal area of the surface.*

In the example given above the thrust on each square centimetre is 50 grammes weight, it is uniformly distributed; but suppose that, instead of placing 50 grammes on each square centimetre, the weights were irregularly placed, so that on some squares there were more than 50 grammes, on others less, while the total weight carried remained the same; the total thrust would remain the same, but its distribution would be variable.

In the illustration it is of course possible that the thrust of 50 grammes weight which acts across each square centimetre may not be uniformly distributed over that square centimetre; if we suppose the square centimetre to be divided into a large number of very small equal areas and if the thrust on each of these areas be the same, then the distribution over the square centimetre is uniform, this case is included in the definition by the introduction of the word "every."

18. Pressure at a Point. It is found convenient to give a name to the thrust per unit area of any surface.

DEFINITION. *When a thrust is uniformly distributed over a surface, the thrust on each unit of area is called the Pressure at each Point of the surface.*

Now let P be a thrust which is uniformly distributed over a surface, let p be the pressure at each point of the surface, and let a square centimetres be the area of the surface,

Since on each square centimetre there is a thrust p , on a square centimetres the thrust is pa , but the total thrust is P . Hence

$$P = pa,$$

and

$$p = \frac{P}{a}.$$

Thus *The Pressure at each Point of a surface exposed to a uniform thrust is found by dividing the thrust on the whole surface by the number of units of area it contains.*

Now, even when the thrust is variable over the surface, we may treat it as uniform over a small area—a square centimetres—if that area be sufficiently small; and in this case, if P be the total thrust on the area, the ratio P/a gives the pressure at each point of the area.

DEFINITION. *When the thrust over any surface is not uniformly distributed the Pressure at each Point of the surface is the ratio of the thrust on a small portion of the surface which includes the point to the area of that portion when that area is sufficiently small.*

Thus, if P be the thrust on a surface of area a under variable pressure, p the pressure at each point of that surface, then

$$p = \frac{P}{a},$$

when a is taken so small that the thrust over the portion of surface considered may be treated as uniform.

19. Average Pressure. The ratio of the total thrust on any plane surface to the area of that surface is known as the **Average Pressure** at each point of the surface: if the total thrust be P , and the area of the surface a , then the average pressure is P/a .

If the thrust be uniformly distributed the average pressure and the pressure at each point are the same; if the thrust be variable, the pressure at any point, is the average pressure on a portion of the surface containing the point, and so small that the distribution of thrust over that portion may be treated as uniform.

If a , the area of the surface, be unity, we see that the average pressure is equal to the thrust on the surface. Thus *The Average Pressure is the thrust per unit of area.*

20. Examples of Uniform and Variable Thrust.

If we consider a horizontal surface above which a mass of sand is piled, there will be a thrust on the surface, arising from the weight of the sand: if the sand be piled to a uniform depth all over, the thrust will be uniform, and the pressure at each point of the surface the same; if, on the other hand, the upper surface of the sand be uneven, the thrust will usually be variable and the pressure will differ from point to point.

Or again, consider a rectangular vessel filled with water having vertical sides and a horizontal bottom; the vertical forces acting are the weight of the water and the upward thrust of the bottom, these two are equal; moreover the thrust is uniformly distributed and the pressure is the same at each point of the base. The same would be true if the vessel contained a solid which just filled it, but the solid would exert no force on the sides of the vessel; when, however, it contains fluid each side is subject to a horizontal thrust the amount of which can be calculated. This thrust, it can be shewn, is not uniformly distributed, the force on any small portion of the surface near the top of the liquid is less than that on an equal portion near the bottom, the pressure is variable from point to point. Thus the pressure at the bottom of a dock of uniform depth is uniform, that on the dock gates is variable.

21. Units of Pressure.

The pressure at a point is found we have seen by dividing the thrust or normal force impressed on a definite surface by the area of that surface; we therefore speak of a pressure of so many units of force per unit of area; the numerical measure of a pressure depends on the unit of force and on the unit of area.

We may express it in dynes or in grammes-weight per square centimetre, or in poundals per square foot. A common unit of pressure adopted in England is pounds-weight per square inch.

Suppose, for example, it is found that the force acting on a surface 100 square centimetres in area is 50 kilogrammes weight, and that the pressure is uniform; the pressure at each point of the surface is $50/100$ or $\cdot 5$ kilogrammes weight per square centimetre. Similarly, if the force on a square $1/100$ of a square inch in area be 2 lbs. weight, then the pressure is $2/\frac{1}{100}$ or 200 lbs. weight per square inch.

It must be clearly remembered that pressure is not force. In order to determine the thrust or force, impressed normally on a given plane surface by fluid pressure uniformly distributed, we must *multiply the pressure at each point by the area of the surface*. If the pressure is not uniform, the problem of finding the total thrust is more complex; if the average pressure at each point be known, the thrust is found by multiplying the average pressure by the area.

Examples. (1) *A surface is subject to a pressure of 15 lbs. weight to the square inch; determine it in grammes weight per square centimetre, and also in dynes per square centimetre.*

1 square inch contains $(2\cdot 54)^2$ or $6\cdot 45$ sq. cm., 1 lb. contains 453·6 grammes.

Thus the thrust on an area of $6\cdot 45$ sq. cm. is $15 \times 453\cdot 6$ grammes weight.

Hence the pressure is $15 \times 453\cdot 6/6\cdot 45$ grammes weight per square centimetre or 1055 grammes' weight per square centimetre.

Now the weight of 1 gramme contains 981 dynes.

Hence the required pressure is

$$1055 \times 981 \text{ or } 1\cdot 033 \times 10^6 \text{ dynes per sq. cm.}$$

Thus the pressure in question, which we shall see is about that exerted by the atmosphere, is equivalent approximately to a weight of 1 kilogramme per square centimetre; we might produce it by erecting a vertical tube 10 metres (1000 cm.) high and one square centimetre in area; if such a tube were filled with water the thrust on the base 1 sq. cm. in area would be the weight of 1000 c.cm. of water or 1 kilogramme.

(2) *The total thrust on a surface 5 square feet in area is found to be the weight of 1 ton, find the average pressure in lbs. weight per square inch.*

The surface contains 5×144 or 720 square inches, one ton is 2240 lbs.

Thus the pressure is $2240/720$ or $3\frac{1}{3}$ lbs. weight per square inch.

(3) *Taking the atmospheric pressure at 15 lbs. weight per square inch, find the weight supported by a square mile of the earth's surface.*

One square mile is 4,014,489,600 square inches; the thrust in pounds weight is found by multiplying this by 15. It is therefore 60,217,334,000 lbs. weight.

22. Graphical Solutions.

The following graphical method of representing the pressure at any point of a plane surface is sometimes convenient.

We have seen that pressure is measured by the force impressed per unit of area: taking a square centimetre as the unit of area, the pressure may be given as so many grammes weight per square centimetre: now imagine the surface to be horizontal and erect on each square centimetre a vertical column of some homogeneous substance, of such a height that its weight may be equal to the force exerted by the fluid on the square centimetre which supports the column. Since the weight of a cubic centimetre of water is 1 gramme weight if the column be of water, h cm. in height, its weight will be h grammes; this is supported by the portion of the surface, 1 square centimetre, on which it rests, and if the weight of this column is to represent a pressure of p grammes weight per square centimetre, we must take h equal to p . Hence the pressure may be represented by the height of a column of water 1 sq. centimetre in area. The number of centimetres in the height of this column will be equal to the number of units of pressure in the pressure it represents.

The height of this column of liquid is sometimes spoken of as the "head" of liquid which gives the pressure. Thus we might speak of the pressure of the atmosphere, which is about 1 kilogramme weight per sq. cm., as due to a "head" of water 10 metres in height.

There is no need to select water as the substance by the aid of which the pressure is measured; it is, however, in most cases convenient to do so.

23. Pressure within a Fluid.

So far we have dealt with the thrusts which a fluid exerts on a surface with which it is in contact; we may compare these

to the force between a solid block such as that shewn in Fig. 1 above, and the table on which it rests. But we have seen (Section 15) that we must, in the case of the block, suppose stresses to exist throughout its substance. For a horizontal plane such as CD , Fig. 1, we have a normal thrust exerted in opposite directions on the two sides of the plane; if the plane be oblique as in Fig. 2, the normal thrust is accompanied by two tangential forces constituting a shearing stress.

In the same way stresses exist throughout the substance of any fluid.

Consider a mass of fluid in a vessel and suppose, for simplicity, that the sides of the vessel are vertical; imagine a horizontal plane CD , Fig. 5, drawn in the fluid. The forces

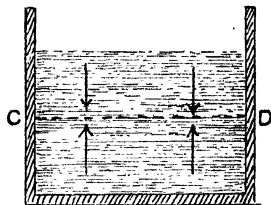

Fig. 5.

are its weight and the downward thrust of the atmosphere on its upper surface—these act in a vertical direction—together with the thrusts of the sides; the directions of these last forces are horizontal and they are in equilibrium among themselves. In order then that equilibrium may be maintained there must be an upward vertical thrust across the horizontal plane CD , equal to the sum of the weight of the fluid above the plane, and the downward thrust due to the atmosphere.

Or again, if the plane CD be inclined to the horizon, as in Fig. 6, there will, as in the solid, be a stress across it; this stress however will differ from that in the solid in that the forces which compose it are at right angles to CD . In the fluid there can be no stress along CD such as exists in the solid. In the fluid there is therefore a thrust across CD , this thrust has a vertical component which balances the sum of weight of the fluid above and the downward

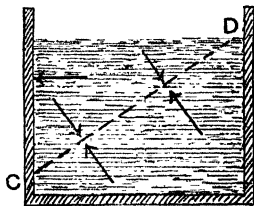

Fig. 6.

vertical thrust of the atmosphere; it also has a horizontal component and this balances the resultant horizontal thrust on the vertical sides of the vessel. In the solid the resultant force across CD , Fig. 2, is vertical; there is no force on the vertical sides and hence no horizontal component to the force across CD . There is, in consequence, a shearing stress in the solid across CD . The fluid cannot support such a stress, the wedge of fluid above CD , Fig. 6, would change in form and slide down were it not for the thrusts impressed on it by the sides of the vessel.

24. Pressure at a Point within a Fluid.

Consider now a small plane surface of area a immersed in a fluid; the fluid on either side of the surface exerts a thrust on the surface; if the fluid on one side could be removed it would be necessary to exert a force on that side in order to balance the fluid thrust on the other. Let the magnitude of this force be P . Then P measures the thrust in the fluid across the surface of area a .

The ratio P/a is defined as the **Average Pressure** at each point of the surface.

If the thrust over the surface be uniformly distributed then the ratio P/a is the **Pressure at each Point** of the surface. If the thrust over the surface be not uniformly distributed then, in order to find the pressure at any point, it is necessary to reduce the area of the surface until it is so small that the distribution of thrust over it may be treated as uniform; when this is the case the ratio P/a measures the pressure at any point of the surface.

DEFINITION. *In order to find the pressure at a point of a fluid, imagine a small plane surface of area a immersed in the fluid so as to contain the point. The **Pressure at the Point** is measured by the ratio of the thrust on one side of the surface to the area of the surface, when that area is so small that the distribution of thrust over it may be treated as uniform.*

The meaning of the term pressure at a point may perhaps be made clearer from the following. Let A , Fig. 7, be a point in a fluid at which the pressure is required. Imagine a small plane surface placed at A and a tube inserted in the fluid in such a way that the surface may form a piston in the tube; suppose further that it is possible for the piston to move without friction in the tube. Now let all the fluid be removed from the tube on one side of the piston: the thrust on the other side will drive the piston down the tube unless force be applied to it; suppose that a force P applied at right angles to the piston holds it in its place, then P measures the thrust on the piston and if a be the area of its surface P/a is the average pressure at each point of its surface. If the area of the piston be so small that the thrust may be taken as uniformly distributed P/a will be the pressure at each point.

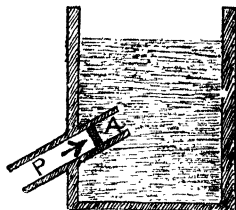

Fig. 7.

The arrangement described above does not constitute a practical means of measuring the pressure; it is not an experiment to illustrate the measurement of pressure; it is merely an illustration, impossible to realize in practice, of what is meant by fluid pressure. Practical means of measuring the pressure at a point will be given in Sections 36—40.

25. Pressure in different directions.

At any point in a solid imagine a small surface drawn, containing the point, and consider the thrust across this surface; it will of course depend on the forces which act on the solid; it will also, in general, depend on the direction within the solid in which the surface is drawn, thus, if the weight of the substance be the only force, there will be a normal thrust on a horizontal surface but no normal thrust on a vertical surface; the thrust depends on the direction of the surface. This is not the case in a fluid; the thrust on a surface of very small area placed at a given point is the same in whatever direction the surface be placed.

If, when the surface be horizontal, there be a thrust of P grammes weight upon it, then it can be shewn that there is the same thrust upon it when it is vertical, or in any other position, so long as it is sufficiently small and passes through the given point. In fact it follows from the fundamental definitions that,

The pressure at a point in a fluid is the same in all directions about the point.

The direction therefore of the small surface placed in the fluid so as to form a piston in the illustration given in the last section is immaterial, the thrust upon it is not changed by turning it about any point in itself.

This fundamental property can be deduced from the fact that there is no shearing stress in a fluid. The proof is given below (Proposition 6). A direct experimental proof would require somewhat complicated apparatus, the law however is involved in many of the experiments which will be described, and the student, who finds a difficulty in following the mathematical proof, may believe it because the results of experiment bear out theoretical deductions from the law.

The proof that the pressure is the same in all directions about a point is based on the following considerations. Suppose that all the particles of a fluid are acted on by some force, such as their weight, and consider the matter which lies within some surface drawn in the fluid; the resultant impressed force acting on this matter will be proportional to the volume of fluid within the surface, and this force is balanced by the thrusts on the surface arising from the fluid pressure.

Thus if, to make ideas definite, we consider a small cube in the fluid and suppose the weight of the fluid to be the only impressed force, the forces acting on the cube are the weight of the fluid which it contains and the six thrusts, one on each of the six faces of the cube; the resultant of these thrusts therefore must balance the weight. Now the thrust on each face is proportional to the area of the face, while the weight is proportional to the volume of the cube. Thus we have the resultant of six forces, which depend on the area of the faces, balancing a force which depends on the volume of the cube.

Suppose now that the cube is reduced in size so that each edge becomes—say— $\frac{1}{10}$ th of its previous length, the faces will then become $\frac{1}{100}$ th of what they were while the volume of the tube will be $\frac{1}{1000}$ th of its previous value; the forces then which depend on the surface will be reduced 100-fold, those which are proportional to the volume will be reduced 1000-fold, or ten times as much; if the edge be again reduced to a

tenth, the forces proportional to the volume will again be reduced ten times as much as those which depend on the area of the surface.

Thus, proceeding in this manner, we see that we can make the forces which depend on the volume as small as we please when compared with those which depend on the surface; in the end, then, when the cube has become very small its weight may be neglected in comparison with the forces which arise from fluid pressure, and these forces form a system in equilibrium among themselves.

This statement is true whatever be the shape of the small portion of the fluid which we consider; let us apply it to a small triangular prism in the fluid.

**PROPOSITION 6. To prove that the pressure at a point in a fluid is the same in all directions about the point.*

Let ABC , Fig. 8, be a small triangle in the fluid, draw lines AA' , BB' , CC' each l centimetres in length at right angles to ABC ; join $A'B'$, $B'C'$ and $C'A'$ and consider the portion of fluid within the prism thus formed.

Let a , b , c be the lengths of the sides of the triangle BCA , p_1 , p_2 and p_3 the average fluid pressures on the faces $BCC'B'$, $CAA'C'$, $ABB'A'$ respectively. The areas of these faces are respectively la , lb and lc square centimetres, hence the normal thrusts are $la p_1$, $lb p_2$, and $lc p_3$.

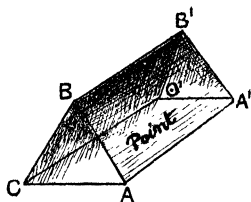

Fig. 8.

Now we have seen that when the prism is made very small, these three forces form a system in equilibrium among themselves; but, when three forces are in equilibrium, they can be represented by the sides of a triangle to which they are parallel.

The three forces in question are at right angles to the sides of the triangle ABC , hence, if this triangle were turned through a right angle in its own plane, its sides would be parallel to the directions of the forces; thus the three forces

are respectively proportional to the sides a , b , c of the triangle BCA .

The ratio then of each force to the corresponding side must be the same for all the forces. Now these ratios are

$$p_1 l a / a, p_2 l b / b \text{ and } p_3 l c / c.$$

Hence
$$p_1 l = p_2 l = p_3 l,$$

or
$$p_1 = p_2 = p_3.$$

Thus the average pressure on each face is, when the prism is made very small, the same; but, in this case, the average pressure on a face is the pressure at the point, to which the triangle is reduced, estimated in the direction of the normal to that face: thus the pressures at right angles to the faces of any very small prism enclosing the point are ultimately equal, or in other words,

The pressure at a point in a fluid is the same in all directions about that point.

It should be noticed that the proof depends on the fact that the force on each face is at right angles to that face; if there were a shearing force parallel to the face as well as the simple thrust the proposition would not be true.

We may put the proof in mathematical form thus. Let $ABCC'B'A'$ be a small triangular prism in the fluid. Let the face $ACC'A'$ be horizontal. Let l be the length of the prism; a , b , c , the sides of the triangle BCA .

Let p_1 , p_2 , p_3 be the average pressure on the faces, and ω the weight of a unit of volume of the fluid.

Let d be the perpendicular distance of the vertex B from the base CA .

The volume of the prism is $\frac{1}{2} b d l$ and its weight is $\frac{1}{2} \omega b d l$; this force acts vertically and is therefore at right angles to the face $ACC'A'$.

The other forces are $p_1 a l$, $p_2 b l$ and $p_3 c l$ at right angles to the faces.

Resolve these vertically

$$p_2 b l = \frac{1}{2} \omega b d l + p_1 a l \cos C + p_3 c l \cos A.$$

Resolve the forces horizontally

$$p_1 a l \sin C = p_3 c l \sin A.$$

But we know that $a \sin C = c \sin A$.

Thus

$$p_1 = p_3,$$

also

$$b = CA = a \cos C + c \cos A.$$

Hence substituting in the first equation

$$\begin{aligned} p_2 b &= \frac{1}{2} \omega b d + p_1 (c \cos A + a \cos C) \\ &= \frac{1}{2} \omega b d + p_1 b. \end{aligned}$$

Thus

$$p_2 - p_1 = \frac{1}{2} \omega d.$$

Now when the prism is made very small, so that p_1 and p_2 become the pressures in two different directions at a point, then d is indefinitely small. The difference therefore between p_1 and p_2 can be made as small as we please, or p_1 is equal ultimately to p_2 .

Hence ultimately

$$p_1 = p_2 = p_3.$$

Now p_3 is the pressure in a vertical direction, p_1, p_2 pressures in any other two directions. Hence the pressure in a vertical direction is equal to that in any other, thus the pressure is the same in all directions about a point.

26. Transmissibility of Fluid Pressure.

If the pressure at any point of a fluid is changed, that at all other points is changed also; it follows, from the fundamental property of a fluid, that, for a liquid, the change of pressure at all points is the same.

A fluid in this respect differs from a solid. Imagine a cylinder fitted with a piston and place in it a portion of a solid which just fits the cylinder loosely. Put weights on the piston, the force thus applied to the top of the solid is transmitted to the base; unless the solid expands laterally under the force, so as to fit the cylinder more tightly, there will be no pressure on the sides; if, however, the substance in the cylinder is a fluid this is no longer the case; the addition of the weights increases the pressure or force per unit of area on the top of the fluid, this increase is transmitted by the fluid in all directions; the pressure at each point is increased and, as we shall shew, for a liquid, the increase of pressure is the same at all points.

This may be illustrated by the following arrangement.

Imagine a vessel fitted with a number of openings, each closed by a piston, as shewn in Fig. 9; suppose the whole to be filled with liquid. In order to keep the pistons in their place a force must be applied to each. Suppose now that the force on any one piston is increased, the other pistons will be driven out, and in order that equilibrium may be maintained it is necessary that additional force should be applied to each of them.

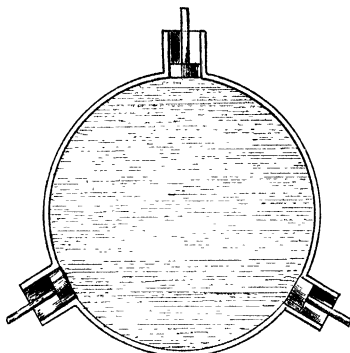

Fig. 9.

If we could secure frictionless pistons, all of the same area, it would be found that

the additional force applied to each piston would be the same; if, however, the pistons differ in area, the force necessary to maintain any piston in position would be found to be proportional to the area of the piston; the ratio of the force to the area over which it is applied is the same for all.

An increase of fluid pressure applied at one point is transmitted equally to all other points.

The experiment in this form is impossible; we cannot obtain frictionless pistons. The principle, however, is illustrated by the action of various pieces of apparatus which will be described shortly, see Sections 27, 28, and by some experiments which will be better understood when we have considered some of the methods for measuring fluid pressure. We proceed now to give a formal proof of the principle.

PROPOSITION 7. *An increase of pressure, at any point of a liquid at rest, is transmitted without change to every other point.*

For let A, B , Fig. 10, be two points within the liquid.

(i) Suppose first that the line AB lies entirely within the liquid.

Construct a small cylinder, having the line AB for its axis, and consider the forces acting on the fluid within this cylinder. They are

(1) the thrusts on the ends A and B , parallel to the axis AB ,

(2) the thrusts on the curved surface at right angles to the axis,

(3) the resultant of the external impressed force.

Now the liquid is in equilibrium and the thrusts on the curved surface have no component parallel to the axis.

Thus the difference between the thrusts on the two ends must balance the component of the impressed force in the direction of the axis.

But this component remains the same even though the pressure be changed.

Hence the difference between the thrusts on the ends A and B is a constant; but the areas of these ends are equal.

Thus the difference between the pressures at the two ends is always the same.

Hence, if by any means the pressure at the point A is increased, that at B is increased by the same amount, otherwise the difference between the two would change and it has just been proved that this difference is unchanged.

(ii) Suppose that the line AB does not lie entirely within the liquid.

Join the points A and B by a series of straight lines AP , PQ , QB , Fig. 11, etc. each of which does lie entirely in the liquid. Then the proposition just proved holds for each of the pairs of points A , P . P , Q etc.

Hence if the pressure at A be increased, that at P is increased equally; but if the pressure at P is increased that at Q is increased equally, and so for all the points. Hence the increase of pressure at B is equal to that at A .

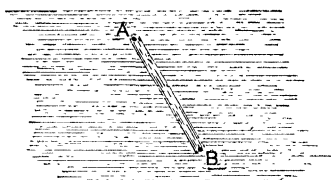

Fig. 10.

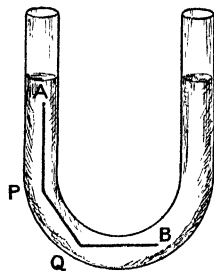

Fig. 11.

Thus any increase of pressure produced at any point of a liquid in equilibrium is transmitted without change to every other point.

The proposition is not true, for a gas or compressible fluid, in any case in which it is necessary to take into account the weight or other force impressed on the gas; for if a gas be subject to increased pressure its volume is diminished and its density is increased.

The weight therefore of the gas within the cylinder AB is changed by the change of pressure, and in consequence the difference of pressures between the two ends is changed also.

The density of a gas is however usually very small, the weight therefore of a limited portion is generally small compared with the force to which each unit of area of its surface is subject; for many purposes we may omit the consideration of the weight of the gas entirely and may suppose that in the case of a gas we are dealing with a fluid acted on throughout its mass by no impressed forces. We may shew that in this case the pressure is the same at every point.

PROPOSITION 8. *To prove that if a fluid be acted on by no impressed force the pressure is the same at every point.*

Let A, B , Fig. 12, be two points in such a fluid. Join AB and suppose the line AB to be entirely within the fluid. Construct a small cylinder about AB as axis. The cylinder is in equilibrium under

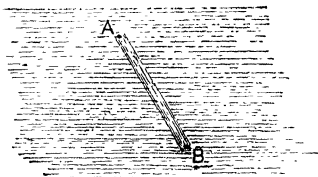

Fig. 12.

(1) The thrusts on the two ends acting parallel to the axis.

(2) The thrusts on the curved surface acting at right angles to the axis.

Hence the thrusts on the two ends are equal and opposite; but the areas of the ends are the same.

Thus the pressures at the two ends are equal.

But A and B are any two points in the fluid. Hence the pressure is the same at any point in the fluid.

If the line AB does not lie entirely in the fluid the proof can be extended as in Proposition 7 (ii).

Thus, provided the volume of gas considered is so small that its weight may be neglected, we may take the pressure in a gas to be the same at all points.

The above statement would not of course apply to the pressure throughout any large volume of a gas such as the atmosphere. The pressures at the top and bottom of a mountain are very different. Delicate pressure gauges will enable us to detect the difference in pressure between the attics and the basement of a house.

27. Hydrostatic Bellows.

This apparatus, designed by Pascal, illustrates the principle of the transmissibility of pressure in a fluid. A stout bladder, such as is used for a football, or a leather bellows, is attached to a piece of tube. The tube is fixed in a vertical position and the bladder rests on the table. A piece of light board is placed on the bladder and a weight rests on the board.

Water is then poured down the tube; the water flows into the bladder, causing it to expand and raise the weight; the level of the water in the tube stands, as at *C*, Fig. 13, some distance above the level of the board.

To explain the action, we notice that the weight is supported by the upward thrust of the water on the underside of the board; this upward thrust depends, partly on the pressure of the water and partly on the area of the surface of the board which is in contact with the bladder, and its value is obtained by finding the product of the

two; if, therefore, the area in contact with the board be large, the upward thrust may be considerable, even though the pressure is not large. Suppose now, when the whole is in equilibrium, the level of the water in the tube is at *B*. Let more water be poured into the tube, and suppose that the weight does not rise.

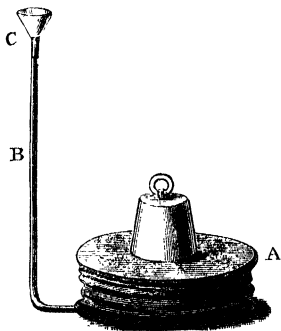

Fig. 13.

The downward thrust over the surface of the water at B is increased by the weight of the water poured in, the pressure therefore at B is increased.

Hence, if w be the weight of water poured in and a the area of the section of the tube, the increase in the thrust on the area a at B is w ; thus the increase in pressure is w/a . This increase of pressure is transmitted equally to all points, hence the upward pressure at all points of the under surface of the board is increased by w/a . Let the area of this surface be A , then the total upward thrust is increased by Aw/a .

In order that the board may not rise the weight upon it must be increased by an amount W equal to Aw/a . If the weight be not increased the board will rise and the level of the water in the tube will sink, thus reducing the pressure until equilibrium is again established.

In this arrangement we see that a weight w of water can support a weight W placed on the board and that

$$W = \frac{wA}{a}.$$

Hence, if A is large compared with a , W will be large compared with w . By making the area of the board considerable and that of the tube small, a large weight W can be supported by a small weight w of water.

This fact is sometimes described as the hydrostatic paradox: the principle involved in the above experiment is made use of in Bramah's Press (see Section 94).

Example. *The area of the tube used in an experiment like that described in Section 28 was 10 square millimetres, the area of the board 100 square centimetres. If 10 grammes of water are poured into the tube, find the additional weight which the board can support.*

We have 10 sq. mm. = .1 sq. cm.

Thus the increase of pressure is 10/.1 or 100 grammes weight per square centimetre. The increased upward thrust on the board 100 sq. cm. in area is 100 × 100 or 10000 grammes weight. Thus if the board is not to rise an additional downward force of 10 kilos weight must be applied to it.

28. Illustrations of Fluid Pressure.

The apparatus shewn in Fig. 14 again illustrates the transmissibility of fluid pressure. In it M and N are two cylinders of different diameters which are filled with water and communicate through a tube at the bottom. They are fitted with pistons; the pressure at any point of the two pistons is the same; the upward thrusts on the pistons are proportional to their areas; thus, if a downward force w be applied to the smaller piston, a larger force W must act on the larger piston in order to maintain equilibrium.

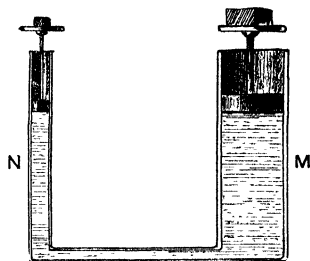

Fig. 14.

If the pistons be assumed to be frictionless, the relation of W to w is found thus:

Let A , a be the areas of the two pistons respectively. Then on the smaller piston there is a downward thrust w , the thrust per unit area of the piston is therefore w/a ; this then is the pressure in the fluid and it is transmitted to each unit of area of the piston A . The total upward thrust then on this piston is Aw/a and this upward thrust must balance W . Hence

$$W = \frac{Aw}{a},$$

or

$$\frac{W}{A} = \frac{w}{a}.$$

In consequence of the friction, however, the relation of W to w given by experiment would differ from this.

Numbers of other illustrations of the effects of fluid pressure can be given. Thus

- (i) Fill with water a glass tube 30 or 40 cm. in length.

closed at one end, and place it with its open end downwards, in a vessel of water; the water remains in the tube, as shewn in Fig. 15; the pressure of the air on the free surface of the water in the vessel is transmitted to the water in the tube. The upward thrust over the open end of the tube is sufficient to support the contained water.

(ii) Repeat the experiment with a tube, one end of which is closed with a piece of thin india-rubber, the india-rubber is stretched and takes the form shewn in Fig. 15, the pressure on its upper surface is greater than that exerted by the water on the lower surface.

(iii) Again, take a hollow cylindrical vessel, such as a tin can or bucket, and place it bottom downwards in a vessel of water, the can floats; to sink it under water force is necessary, the upward thrust arising from the fluid pressure is greater than the downward force, the weight of the vessel, hence it floats; if a small hole be bored in the bottom the water spouts up in a jet.

(iv) Place a small beaker or tumbler mouth downwards in water, as in Fig. 15 a, and depress it below the surface; the water rises in the beaker, compressing the air it contains; the greater the depth to which the beaker is lowered, the greater will be the compression; the pressure in the water increases with the depth.

(v) The water supply of a town usually comes from a reservoir at some height above the town, in consequence the water in the pipes is under pressure; a jet of water allowed to flow from a hose-pipe will rise to a height which depends partly upon this pressure.

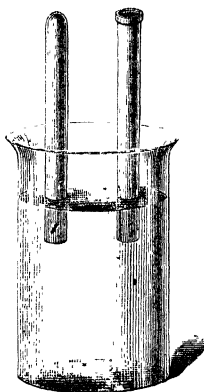

Fig. 15.

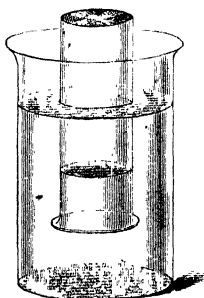

Fig. 15 a.

(vi) If a fluid be allowed to escape from a tall vessel through a hole in the side, the velocity with which it flows out depends on the pressure; if holes be made at various depths, as in Fig. 16, in the side of the vessel, the water flows more rapidly from the lower holes than from those above; the pressure is greater at the greater depth. This can be shewn by measuring the amount which flows from each

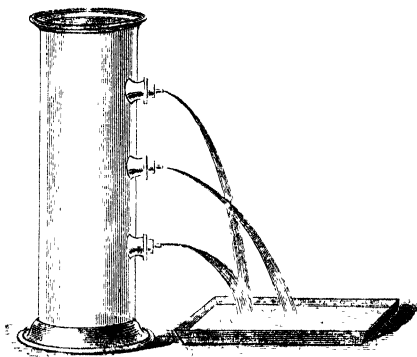

Fig. 16.

hole in a given time; the level of the water in the vessel must be kept constant by some arrangement during the experiment.

(vii) Grind the end of a glass tube flat, cover it with a plate of flat glass and hold the glass against the bottom of the tube with a string, as shewn in Fig. 17. Lower the whole some depth into a vessel of water and release the string, the glass remains in contact with the end of the tube and does not fall off. The upward thrust, due to the pressure of the water on the bottom of the glass, is more than sufficient to counterbalance its weight.

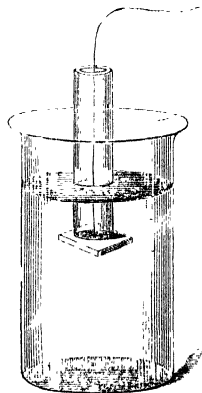

Fig. 17.

In the next chapter we give some fundamental propositions on fluid pressure when the only force acting on the fluid is its weight. We then describe some experiments on the measurement of fluid pressure and the numerical verification of some of the laws.

CHAPTER III.

PROPOSITIONS ON FLUID PRESSURE.

29. Fluid Pressure.

We assume in the following propositions¹ that the only forces, impressed on the portion of fluid which we consider, are the thrusts due, either to the action of surrounding fluid, or to solids with which the fluid is in contact, together with the weight of the portion of fluid considered.

If then we take any portion of the fluid, say that within some small sphere or cylinder, described in the fluid, the forces on this portion of fluid are the thrusts on its surface and its weight; these forces must form a system in equilibrium: we can determine from this the relation between the fluid pressure and the weight.

Proposition 9 deals with the pressure at points at the same level in a fluid.

Two cases of this proposition arise.

(i) It may be possible to join the two points by a straight horizontal line or a series of straight horizontal lines which lie entirely in the fluid; thus any two points in an ordinary bath of water could be joined by a straight line. Suppose, however, that there is a sponge or a piece of soap in the bath,

¹ Similar propositions may be proved in a very similar way for a fluid at rest under other forces than its weight. For these the reader is referred to Greaves' *Elementary Hydrostatics* (Cambridge University Press).

then a point on one side of the soap cannot be joined by one straight horizontal line to a point on the other side without cutting the soap; we can however join the two points by means of two or more such lines.

(ii) It may be impossible to join the two points by horizontal lines lying entirely in the fluid; thus, if there is a vertical partition stretching completely across the bath and reaching part way down, a point on one side of this cannot be connected with a point on the other side by horizontal lines lying entirely in the fluid; the same is true of two points, one in each leg respectively, in a fluid filling a **U** tube.

Proposition 9 applies to the first case; the second is dealt with in Section 30.

PROPOSITION 9. *If a fluid be at rest under the action of gravity, the pressures are equal, at any two points which can be joined by a single straight horizontal line lying wholly within the fluid, or by a series of such lines.*

In Fig. 18, let A , B be the two points in the same horizontal plane.

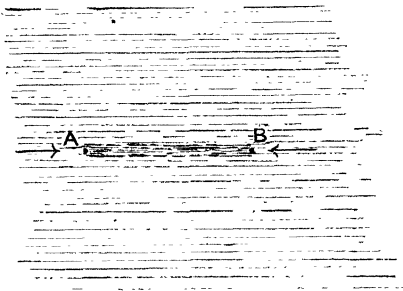

Fig. 18.

(i) Suppose that the straight line AB lies wholly within the fluid.

About AB construct a cylinder of very small section with its ends at right angles to AB and consider the forces impressed on the cylinder.

They are

(i) The thrusts on the ends A , B which act in opposite directions along AB .

(ii) The thrusts on the curved surface of the cylinder which are everywhere at right angles to AB .

(iii) The weight of the fluid within the cylinder, the line of action of which is vertical and therefore at right angles to AB .

Thus the only impressed forces in the direction of AB are the thrusts at A and B ; these forces then must be equal and opposite; but the area of the end at A is equal to that at B .

Hence the fluid pressure at A is equal to that at B .

(ii) If AB cannot be joined by a single horizontal straight line lying wholly within the fluid, but by a series of such lines AP , PQ , ... etc., each of which does lie in the fluid, then the proposition is true for each of these lines.

Hence the pressure at A is equal to that at P , the pressure at P is equal to that at Q , and so on; thus the pressures at A and B are equal.

The next proposition deals with the pressures at two points in a fluid, one of which is vertically below the other.

PROPOSITION 10 *To find the difference of pressure between two points in a fluid, one of which is vertically below the other.*

Let A , B , Fig. 19, be the two points and suppose that the line AB lies wholly in the fluid.

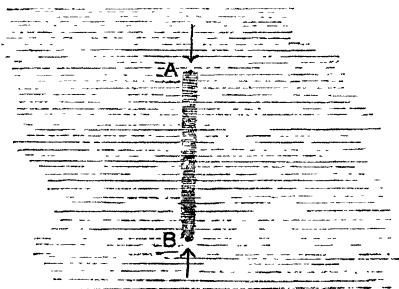

Fig. 19.

Consider a small vertical cylinder on AB as axis with its ends perpendicular to AB , let a be the area of either end and let p, p' be the pressures at A and B respectively.

The forces on the fluid composing this cylinder are

(i) The thrusts on the curved surface; these are horizontal, at right angles therefore to AB .

(ii) The thrusts on the ends; the values of these are pa and $p'a$ respectively; they act vertically in opposite directions parallel to AB .

(iii) The weight of the fluid contained in the cylinder; the direction of this force is also vertical, and parallel therefore to AB .

Thus the difference between the thrusts on the ends must balance the weight of the fluid in the cylinder.

Hence $p'a - pa = \text{weight of fluid in the cylinder}$.

Suppose now that the fluid is homogeneous, so that its density is the same throughout; let ω be the weight of a unit of volume; let h, h' be the depths of the points A and B below some fixed horizontal surface.

Then $AB = h' - h$.

Now the volume of the cylinder is $AB \times a$ and its weight is $\omega \cdot AB \cdot a$ or $\omega (h' - h) a$.

Hence $p'a - pa = \omega (h' - h) a$.

Therefore $p' - p = \omega (h' - h)$.

Now $\omega (h' - h)$ is the weight of a column of fluid of unit cross section and of height equal to the vertical distance between the two points.

Hence *The difference of pressure, between two points in the same vertical line, is equal to the weight of a column of fluid of unit cross section, and of height equal to the distance between the points.*

Thus in a homogeneous fluid the difference of pressure between two points in the same vertical line is proportional to the distance between the two points.

Corollary. If the fluid be not homogeneous it is still true that the difference of pressure is the weight of the column of fluid of unit cross section which extends from one point to the other.

30. Pressure at various points in a heavy fluid.

By combining the two propositions just proved we can shew (i) that *In any homogeneous fluid, the pressures at any two points in the same horizontal plane are equal*, and (ii) that *The difference of pressure between any two points is the weight of a column of fluid, of unit cross section, whose height is the vertical distance between the points.*

For suppose that A, B , Fig. 20, be two points in a fluid in the same horizontal plane which, however, because of some barrier cannot be joined by a horizontal line entirely within the fluid.

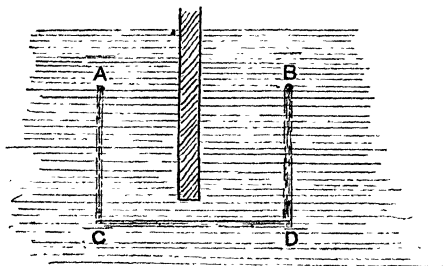

Fig. 20.

Draw AC and BD vertical and let C and D be two points in the same horizontal plane below the barrier which can be so joined.

Join CD . Then, since AB and CD are both horizontal, the distance AC is equal to BD .

The pressure at A is less than that at C by the weight of a column of unit cross section and of height AC .

The pressure at B is less than that at D by the weight of a column of unit cross section and of height BD .

The weights of these two columns are equal, and the

pressure at C is by Proposition 9 equal to that at D , for CD is horizontal.

Hence the pressure at A is equal to that at B .

If it be not possible to pass from A to B , by a single step of the nature indicated, it can always be done by a series of such steps.

To prove (ii) let A, B , Fig. 21, be any two points. Draw BC vertical and from A draw AC horizontal to meet BC in C .

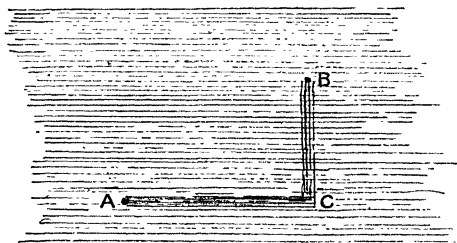

Fig. 21.

Then, by Proposition 10, the pressure at C exceeds that at B by the weight of a column of fluid of unit cross section and of height BC , while by Proposition 9, the pressure at A is equal to that at C .

Hence the pressure at A exceeds that at B by the height of a column of fluid of unit cross section and of height equal to the vertical distance between the points.

If it be not possible to pass from A to B by a single step of the nature just described, it can always be done by a series of such steps.

PROPOSITION 11. *The surface of a liquid, subject to constant pressure and at rest under gravity, is horizontal.*

Let A, B , Fig. 22, be two points in the same horizontal plane in a liquid at rest under gravity. Let π be the constant pressure to which the surface is subject and ω the

weight of unit volume of the liquid. Draw AC and BD vertically upwards to meet the surface in C and D .

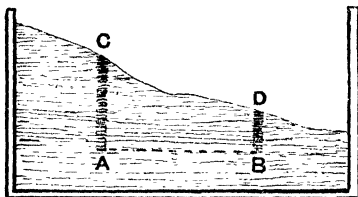

Fig. 22.

Then, since AB is horizontal, the pressures at A and B are equal.

But, the pressure at $A = \pi + \omega AC$,

and the pressure at $B = \pi + \omega BD$.

Hence $\pi + \omega AC = \pi + \omega BD$.

Thus $AC = BD$.

Therefore CD is always parallel to AB ; hence the surface is horizontal.

31. Level Surfaces.

We shall shew later that the atmosphere exerts pressure on the earth's surface. (Section 67.)

The pressure of the atmosphere over a limited area of the earth's surface is, at any moment, a constant pressure; thus the free surface of water in a pond or reservoir is level.

Again, the various propositions just proved are true whatever be the form of the vessel in which the liquid is contained, so long at least as there is free communication between its parts. If water be contained in a bent tube with two vertical limbs, the level of the water in the two limbs of the tube is always the same. Moreover the pressures at any two points in the same horizontal plane, one in each limb it may be, are the same.

If π be the atmospheric pressure on the surface and ω the weight of a unit of volume of the liquid, then the pressure at

a depth h is $\pi + \omega h$. So long as π remains the same the pressure depends only on the depth of the point below the surface.

32. Effective Surface.

We shall find that in a number of cases we need not consider the atmospheric pressure at all, in many others it is necessary to do so. Now we can always represent a pressure as equal to the weight of a column of water—or of some other liquid—of unit cross section and of a definite height; a pressure of 1 kilogramme weight per square centimetre, for example, is equal to the weight of a column of water 1000 centimetres in height and 1 square centimetre in cross section.

Thus we may represent the atmospheric pressure as due to the weight of a column of water; if H_0 be the height of this column and ω the weight of a unit of volume of water, then

$$\pi = \omega H_0.$$

The pressure at a depth h below the surface of water then is

$$p = \pi + \omega h = \omega H_0 + \omega h = \omega (H_0 + h).$$

Suppose now that we consider a horizontal surface at a height H_0 above the surface of the water, then $h + H_0$ is the depth of the point below this surface; this imaginary surface is sometimes spoken of as the **Effective Surface**, and we see that the pressure at a point is proportional to the depth of the point below the effective surface. In this case the height H_0 is called the height of the water barometer (see Section 76).

We may, it is clear, without affecting the circumstances within the water, suppose that its surface is covered with a layer of water of sufficient depth to produce over that surface the pressure which actually exists there; the upper boundary of this layer being free from pressure, and imagine that the thrust over the actual surface is due to the weight of this superposed water and not to the atmosphere. If we are considering the pressure in some other liquid, not water, it will be most convenient to suppose the superincumbent layer to consist of this same liquid.

PROPOSITION 12. *Two liquids which do not mix are placed in a vessel, to find the pressure at a point in the lower liquid.*

Let A , Fig. 23, be a point in the lower liquid. Let

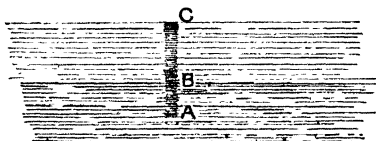

Fig. 23.

ABC drawn vertically from A meet the common surface of the two liquids in B and the upper surface of the upper liquid in C . Let $AB = h$, $BC = h'$. Let ω and ω' be the weights of unit volume of the lower and upper liquids respectively, p , p' the pressures at A and B , π the pressure at C .

Then from the upper liquid we have

$$p' = \pi + \omega' h',$$

and from the lower liquid

$$p = p' + \omega h.$$

Hence

$$p = \pi + \omega h + \omega' h'.$$

The pressure at A is the pressure at the surface together with the weight of a column of unit cross section reaching from A to the surface.

* COROLLARY. *The common surface of two liquids which do not mix is horizontal.*

Let D , Fig. 23 *a*, be a point in the lower liquid at the

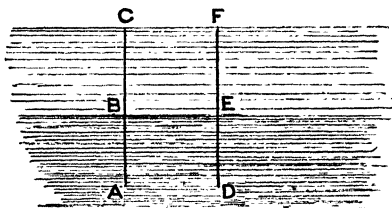

Fig. 23 *a*.

same level as A , and let DEF drawn vertically from D meet the common surface in E and the upper surface in F .

Then, since the free surface is horizontal, FC is parallel to DA .

Hence $DF = AC$.

Therefore $DE + EF = AB + BC$.

Hence multiplying both sides by ω'

$$\omega' \cdot DE + \omega' \cdot EF = \omega' \cdot AB + \omega' \cdot BC,$$

or $\omega' (DE - AB) = \omega' (BC - EF) \dots\dots\dots (1).$

Again, the pressure at D is equal to that at A .

Hence $\pi + \omega' \cdot EF + \omega \cdot DE = \pi + \omega' \cdot BC + \omega \cdot AB$.

Thus $\omega \cdot DE + \omega' \cdot EF = \omega \cdot AB + \omega' \cdot BC$,

or $\omega (DE - AB) = \omega' (BC - EF) \dots\dots\dots (2).$

Hence from (1) and (2)

$$\omega (DE - AB) = \omega' (DE - AB)$$

and this is impossible unless $DE - AB = 0$.

Therefore $DE = AB$, and BE is always parallel to AD .

But AD is horizontal, thus BE is horizontal.

The following experiment proves the truth of Proposition 11.

EXPERIMENT 5. *To prove that the surface of a liquid at rest under gravity is horizontal.*

Suspend a plumb-line above a vessel of water and observe the reflexion of the thread in the water, the reflected image is found to be in the same straight line as the thread. The thread therefore is at right angles to the reflecting surface¹; but the thread is vertical, hence the surface must be horizontal.

33. A Liquid finds its own level.

The law that the free surface of a liquid at rest is horizontal, or, as it is sometimes put, that a liquid finds its own level, is illustrated in many ways.

¹ This result is made use of in Astronomy and Surveying to determine the direction of the vertical at a given point. See *Light*, Section 23.

Thus when as in Fig. 24 water is contained in a number of vessels of various shapes and sizes which all communicate together, the level of the water is the same in all.

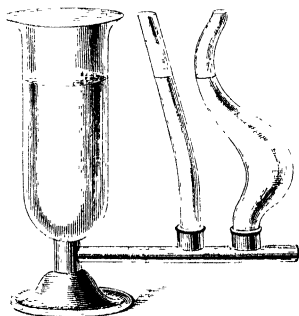

Fig. 24.

The Water Level shewn in Fig. 25 is another illustration of the principle. A long tube is bent at right angles at its

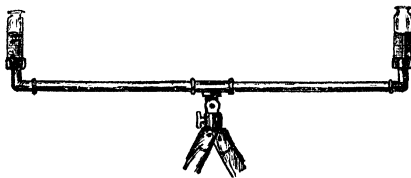

Fig. 25.

two ends; to these small glass vessels are attached, the tube is mounted at its centre on a universal joint and is filled with water slightly coloured. The water rises to the same level in each of the glass vessels; and an observer, placing his eye so as to look along the surfaces of the water, can read differences of level on distant scales towards which the apparatus is pointed in turn.

Fig. 26 shews the tube of a spirit-level; this consists of a



Fig. 26.

closed glass tube nearly filled with alcohol; the bubble of air left in always rises to the highest part of the tube; the tube is slightly bent and is mounted as in Figs. 27 (a) and (b) with its convex side uppermost, and in such a manner that, when the surface on which the instrument is placed is horizontal, the bubble of air may rest between two marks on the glass. The instrument can then be used so as to place in a horizontal position a surface, the level of which is adjustable.

EXPERIMENT 6. *To level a given plane surface with a spirit-level.*

The surface rests on three screws and by adjusting these its level can be altered.

First place the level so that its length may be parallel to the line joining two of the screws as in Fig. 27 (a). Adjust

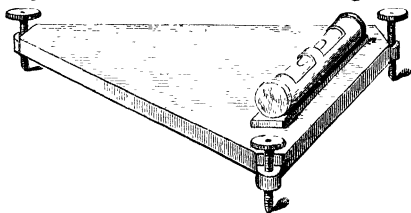

Fig. 27 a.

one of these screws until the bubble is in its central position; then place the level, as in Fig. 27 (b), at right angles to its

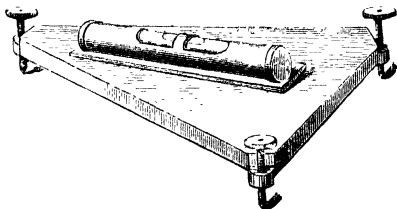

Fig. 27 b.

former position and adjust the surface by the third screw; when the level again reads correctly the surface is horizontal. Test this by placing the level in some other position.

A circular spirit-level is often employed. This is shewn in Fig. 28. A small cylindrical metal box is nearly filled with alcohol and closed by a glass top. The under surface of the glass is slightly concave, so that a bubble of air left above the alcohol rests in the centre when the bottom of the instrument is level. To use the instrument it is placed on the surface to be levelled, and this is adjusted until the bubble rests in its central position.

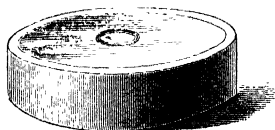

Fig. 28.

A surface which it is required to level and which is not fitted with levelling screws may be conveniently adjusted by the aid of three wedge-shaped slips of wood which are pushed under it or withdrawn from it as required.

34. Units of Pressure.

In the expressions which have been found for the pressure at a point, the units, in terms of which the pressure is to be measured, have not been specifically defined.

These will depend on the unit of length and on the unit of force in terms of which ω , the weight of unit volume of the liquid, is measured. Thus if ω be given in grammes weight per cubic centimetre, and h be measured in centimetres the pressure will be in grammes weight per square centimetre. If ω be in absolute c.g.s. units or dynes per cubic centimetre p is in dynes per square centimetre. Again we may use the English system of units and measure ω in pounds weight per cubic foot; then the depth h must be measured in feet and the pressure is given in pounds weight per square foot. Or we may adopt an entirely different system and measure the pressure by the "head" of some given liquid such as water or mercury which will produce it. We can find the head required from the knowledge that the pressure is equal to the weight of a column of the standard liquid of unit cross section and of height equal to the head.

Examples of both these methods will be given below.

It is sometimes convenient to express the pressure in terms

of the density of the liquid rather than of its weight per unit volume.

Now we know that, adopting the c.g.s. system, the weight of a body in dynes is found by multiplying its mass in grammes by g , the acceleration due to gravity. Thus we have the result that, if W be the weight in dynes of a body whose volume is V cubic centimetres and mass M grammes, and ρ be its density in grammes per cubic centimetre, then,

$$W = Mg = \rho g V.$$

If the volume of the body be unity then the weight W becomes ω , the weight of unit volume, and we see that

$$\omega = g\rho \text{ dynes per cubic centimetre.}$$

Thus the equation $p = \pi + \omega h$ becomes

$$p = \pi + g\rho h.$$

When this equation is used it is assumed that p and π are to be measured in dynes per square centimetre, h being in centimetres and ρ in grammes per cubic centimetre.

If we are employing the F.P.S. system a similar equation holds, ρ being in pounds per cubic foot, h in feet and p and π in poundals per square foot.

Examples. (1) *If the pressure of the atmosphere be taken as 15 lbs. weight per square inch and the weight of a cubic foot of water as 62.5 lbs. weight, find the pressure at depths of (i) 10 inches, (ii) 20 feet, (iii) 50 fathoms, (iv) 1 mile under the surface of water.*

(i) The pressure on each square inch of the surface is 15 lbs. weight. The weight of 1 cubic inch of water is $62.5/1728$ or $.03617$ pound weight.

Hence the weight of a column of water 1 square inch in area, 10 inches in height, is $10 \times .03617$ or $.3617$ lbs. weight.

Thus the pressure at a depth of 10 inches is $15 + .3617$ or 15.3617 lbs. weight per square inch.

(ii) 20 feet = 240 inches.

The weight of a column of water 1 square inch in cross section, 240 inches in height, is

$$240 \times .03617 \text{ or } 8.68 \text{ lbs. weight.}$$

Hence pressure at a depth of 20 feet is

$$15 + 8.68 \text{ or } 23.68 \text{ lbs. weight per square inch.}$$

(iii) 50 fathoms = 300 feet = 3600 inches.

The weight of a column of water 1 square inch in cross section, 3600 inches in height, is

$$3600 \times \cdot 03617 \text{ or } 130\cdot 2 \text{ lbs. weight.}$$

Hence pressure at a depth of 50 fathoms is

$$15 + 130\cdot 2 \text{ or } 145\cdot 2 \text{ lb. per square inch.}$$

(iv) 1 mile = 63360 inches.

The weight of a column of water 1 square inch in cross section, 63360 inches high, is

$$63360 \times \cdot 03617 \text{ or } 2292 \text{ lb. weight approximately.}$$

Hence the pressure required is

$$15 + 2292 \text{ or } 2307 \text{ lb. weight per square inch.}$$

It is clear from this last result that at great depths below the surface of the sea the pressure is enormous.

The various results might have been obtained by a direct application of the formula $p = \pi + \omega h$; they might also have been found in pounds weight per square foot or in other units.

The fact that the weight of 1 cubic centimetre of water is 1 gramme weight, simplifies the numerical work on the c.g.s. system very greatly, for if we work in grammes weight and centimetres we have on this system $\omega = 1$, and the formula for the pressure becomes $p = \pi + h$, or expressing π in terms of H_0 the height of the effective surface $p = H_0 + h$.

In this case the pressure in grammes weight per square centimetre and the "Head" in centimetres are numerically equal.

If the fluid considered be not water but some liquid of specific gravity σ , we have to find the weight of unit volume. On the English system this is $62\cdot 5 \times \sigma$ pounds weight per cubic foot; on the c.g.s. system, it is σ grammes weight per cubic centimetre.

(2) Assuming the atmospheric pressure to be 1 kilogramme weight per square centimetre, find the pressure (i) at a depth of 500 metres in fresh water, (ii) at the same depth in salt water of specific gravity 1.026.

(i) In the fresh water the pressure is

$$1000 + 500 \times 100 \text{ or } 51000 \text{ grammes weight per square centimetre.}$$

(ii) In the salt water the pressure is

$$1000 + 500 \times 100 \times 1\cdot 026 \text{ or } 52300 \text{ grammes weight per square centimetre.}$$

(3) The specific gravity of mercury is 13.6, at what depth in mercury will the pressure be equal to that at 500 metres in sea water?

Omitting the atmospheric pressure which affects both alike, the pressure due to 500 metres of sea water is 51300 grammes weight per square centimetre. Dividing this by the weight of a cubic centimetre in mercury in grammes weight we get the equivalent depth of mercury.

This downward force is usually exerted by a lever, the fulcrum of the lever is fixed, as shewn at *C*; the arm of the lever

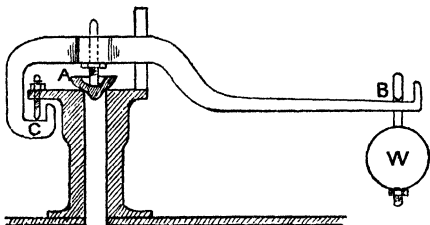

Fig. 33.

presses on the plug at *A*, the extremity of the arm either carries a weight *W*, or, if the boiler be not steady, is attached to a spiral spring.

Let *W* be the weight at *B*, or the downward pull registered by the spring. Let *P* be the upward thrust at *A*, *p* the pressure in the boiler, and *a* the radius of the orifice closed by the plug.

The effective area exposed to vertical fluid pressure is πa^2 , hence the upward thrust is $p \cdot \pi a^2$.

Thus

$$P = p \cdot \pi a^2.$$

But $P \times$ horizontal distance between *C* and *A* = $W \times$ horizontal distance between *C* and *B*.

And hence,
$$p = \frac{W}{\pi a^2} \frac{\text{arm of lever}}{\text{distance of fulcrum from valve}}.$$

If *p* exceeds this value, the steam just begins to escape; the pressure therefore can be measured by adjusting either the weight *W* or the length of the arm *CB* until the steam just begins to blow off.

39. The Bourdon Gauge.

This consists of a tube *AB*, Fig. 34, of thin metal whose axis is bent into the form of the arc of a circle. One end of the tube *A* is closed, the other, *B*, communicates with the vessel in which the pressure is to be measured, the section of the tube is elliptical. Now when the pressure in the tube increases, this elliptical section tends to become circular. This causes the axis of the tube to uncurl slightly so that

the end *A* moves upwards; this slight motion of the tube is communicated to a pointer which moves over a circular scale

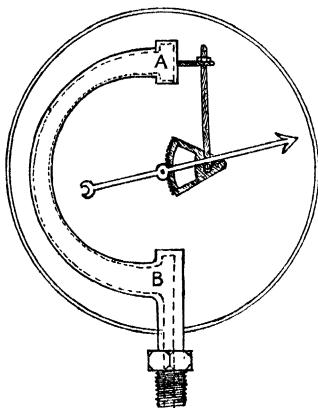

Fig. 34.

by means of a lever working a rack and pinion. The scale is graduated by the application of known pressures and then any pressure applied to the inside of the tube can be measured.

40. Experiments on Fluid Pressure.

We have already described in Section 29 observations on some effects of fluid pressure. Thus the column of water remains in the glass tube, Fig. 15, because the atmospheric pressure at each point of its base transmitted through the fluid is greater than the pressure due to the column of water above. The pressure, however, at the top of the column is less than the atmospheric pressure; hence the stretched india-rubber which covers the top of the tube in the same figure is bulged in.

We may use the apparatus shewn in Fig. 17 to verify some of the laws of fluid pressure. For let us suppose that the radius of the glass tube is *a* centimetres. the area of its cross

section is πa^2 square centimetres; hence if p be the fluid pressure on the glass covering its base, the upward thrust is $p\pi a^2$ and if h be the depth to which it is sunk, the value of p is $\pi + \omega h$ where π is the atmospheric pressure, ω the weight of a unit of volume of the liquid. There is however a downward thrust due to the atmosphere on the upper side of this piece of glass; if we neglect the thickness of the walls of the tube, and suppose therefore that the area of the plate subject to pressure is the same both above and below this downward thrust is $\pi \cdot \pi a^2$.

Hence the resultant upward thrust is

$$(p - \pi) \pi a^2, \text{ or } \omega h \pi a^2.$$

Now let the weight of the glass be W , then when the glass just falls off we see that W must be just greater than $\omega h \pi a^2$; thus we find that when the glass falls off $W = \omega h \pi a^2$.

We can measure these quantities and thus verify the result. Such an experiment would prove that the difference between the pressure at a point in a fluid and the atmospheric pressure is proportional to the depth. To perform it we should hold the glass plate in position by means of the string and immerse it to some depth in the fluid, then loose the string and raise the tube gently until the glass plate just begins to separate from the tube and the water to enter below. Measure the depth to which the tube is immersed, weigh the plate and find the area of the cross section, we have all the quantities required to verify the formula.

Then repeat the experiment, varying the value of W by loading the plate with some convenient weight.

It is troublesome in this experiment to secure a good fit between the tube and the plate. The following experiments verify the laws more satisfactorily.

EXPERIMENT 8. *To shew that the thrust, on a horizontal surface in a liquid, is proportional to the depth and to the density of the liquid.*

You are given a cylindrical vessel containing water and a long cylindrical tube of brass¹. This tube is closed at one end and will float in the water as shewn in Fig. 35. Marks are made on the brass tube at distances of 10, 20, 30 cm. from the bottom. Put shot into the tube until it floats in the water, say up to division 20. Then the tube is entirely supported by the thrust of the water on its base, for the pressures on the sides, being horizontal, cannot help to support it in any way; and hence the weight of the tube and shot is equal to the thrust exerted by the water on its base. Weigh the tube and shot. Let the weight be W_1 . Place in the tube more shot until the tube sinks to division 30. The thrust on the base again balances the weight of the tube and shot. Weigh them again and let their weight be W_2 . Also let P_1 and P_2 be the thrusts on the base in the two cases. Then we have seen that $P_1 = W_1$, $P_2 = W_2$. Now it will be found that the ratio of $W_1 : W_2 = 20 : 30$.

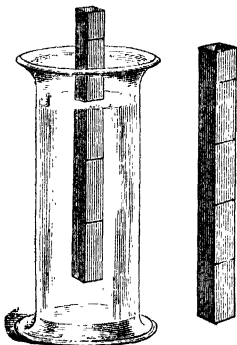

Fig. 35.

Therefore $P_1 : P_2 = 20 : 30$, or the thrusts on the base at two different depths are proportional to the depths.

The thrust at a given depth is also proportional to the density of the fluid. To prove this, place the brass tube in a second jar containing methylated spirit and determine the weight of tube and shot when the former sinks to 30 cm. Let this weight be W_2' . Then we wish to verify that the ratio

$W_2' : W_2 = \text{density of methylated spirit} : \text{density of water}$,
or, since the density of water is 1 gramme per cubic centimetre, that

$$\text{Density of methylated spirit} = \frac{W_2'}{W_2} \text{ grammes per c.cm.}$$

¹ The tube may be circular, instead of square as in the figure, and may be made of a piece of drawn brass tubing; it may conveniently be 35 centimetres in height by from 2 to 3 centimetres in diameter, the diameter of the second tube used in Experiment 8 should be larger than this, say some 4 centimetres.

Look out the density of methylated spirit in the Table and verify this.

Repeat the experiment, using a fluid denser than water, such as a solution of salt.

Thus, *when a horizontal surface is subject to fluid pressure the resultant thrust on the surface is proportional to the depth and to the density of the fluid.*

Since the density is proportional to the weight of unit of volume, we may say that the thrust is proportional to the depth and to the weight of unit volume of the fluid.

EXPERIMENT 9. *To shew that the thrust on a horizontal surface immersed in a fluid is proportional to the area of the surface, and hence to find the pressure at any point in the fluid.*

Measure, by one of the methods given in Dynamics, Section 7, the area of the base of the tube used in the last experiment. If the section is circular it is simplest to measure the diameter of its base with the callipers; let it be d_1 cm. Then the area of the base is $\frac{1}{4}\pi d_1^2$ square centimetres. Determine the weight W_1 grammes of the tube and shot when it floats in water with its axis vertical and 20 centimetres immersed. Repeat the experiment, using a second tube of diameter d_2 centimetres so that the area of its base is $\frac{1}{4}\pi d_2^2$ square centimetres. Let W_2 be the weight of the tube and shot in this case. Then W_1 and W_2 measure the upward thrusts in the two cases and it will be found that

$$W_1 : W_2 = \frac{1}{4}\pi d_1^2 : \frac{1}{4}\pi d_2^2 = d_1^2 : d_2^2.$$

Thus the ratio of the two thrusts is the same as the ratio of the two areas.

41. Deductions from Experiments on Fluid Pressure.

Hence, combining the results of the two experiments 8 and 9,

The resultant thrust on a horizontal surface is proportional to the area of the surface, to its depth, and to the density of the fluid.

Now let p be the pressure at any point of the under side of the surface, and π the atmospheric pressure, which acts

directly on the upper side of this same surface, as well as indirectly, by transmission through the fluid on its under side. The areas subject to the pressures p and π are the same¹, and, for the first tube, are equal to $\frac{1}{4}\pi d_1^2$. Hence the resultant upward thrust for the first tube is

$$(p_1 - \pi) \frac{1}{4}\pi d_1^2,$$

and this is equal to W_1 .

$$\begin{aligned} \text{Thus} \quad (p_1 - \pi) \frac{1}{4}\pi d_1^2 &= W_1 \\ p_1 &= \pi + \frac{W_1}{\frac{1}{4}\pi d_1^2}. \end{aligned}$$

Hence we have measured by experiment the pressure at a depth of 20 cm. in the water.

If the value of $W_1/\frac{1}{4}\pi d_1^2$ be calculated, W_1 being in grammes and d_1 in centimetres, it will be found to be 20; if the tube had been immersed to a depth h the value for $W/\frac{1}{4}\pi d^2$ would be h .

Thus we find that p the pressure at a point, at a depth h in water, is given by $p = (\pi + h)$ grammes weight per square centimetre.

Again, it follows from the experiment that if W' be the weight of the tube and its contents, when sunk to a depth h in a liquid in which the weight of unit of volume is ω , then $W' = \omega \cdot W$.

But in this case if p is the pressure at the depth h in this liquid, we have as before

$$p = \pi + \frac{W'}{\frac{1}{4}\pi d^2} = \pi + \frac{\omega W}{\frac{1}{4}\pi d^2}.$$

And we have just seen that $W/\frac{1}{4}\pi d^2$ is equal to h .

Hence we obtain $p = (\pi + \omega h)$ grammes weight per square centimetre.

We have thus obtained from the experiments an expression for the pressure at a point in a fluid under gravity.

¹ The interior area at the bottom of the tube is of course less than the exterior by an amount depending on the thickness of the walls, but the atmospheric pressure acts vertically downwards at the top of the tube on an area exactly equal to this difference.

***42. Surfaces of Equal Density.**

There are two theoretical propositions of importance with which we may conclude the chapter.

***PROPOSITION 14.** *To shew that the densities at two points in a fluid at rest under gravity at the same depth are the same.*

Let A, B , Fig. 36, be two points at the same depth in a fluid at rest under gravity.

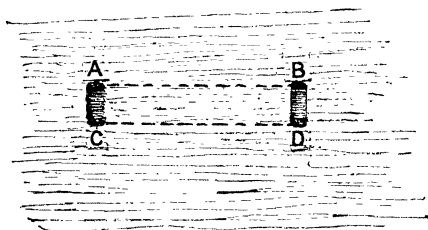

Fig. 36.

The pressures at A and B are equal, let each be p .

Take a point C a very short distance below A and a point D at the same short distance below B , so that $AC = BD$. Then C and D are at the same depth and the pressure at C is equal to that at D ; let the value of this pressure be p' .

If C is very near to A we may treat the fluid as though its density between A and C were constant, and equal to its mean value between these points, let this mean value be ρ_1 ; similarly let ρ_2 be the mean value of the density between B and D .

Then we shall shew that $\rho_1 = \rho_2$.

For, by considering a small cylinder of fluid between A and C , we find

$$p' = p + g\rho_1 AC.$$

While, by considering a cylinder of equal height between B and D , we have

$$p' = p + g\rho_2 BD.$$

Hence

$$\rho_1 AC = \rho_2 BD.$$

But

$$AC = BD.$$

Therefore $\rho_1 = \rho_2$, or the density is the same at two points at the same depth.

Corollary. It follows from this that the common surface of two different liquids which do not mix is a horizontal plane; for, if not, let the surface lie as EF , Fig. 37. Then draw AB horizontal, so that A may be in one liquid, B in the other.

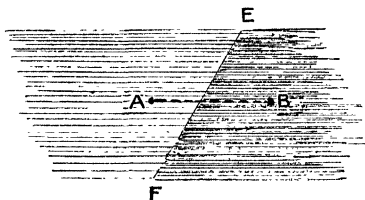

Fig. 37.

The density at A differs from that at B , which is contrary to the proposition just proved; thus EF cannot be as drawn, it must be horizontal.

Thus, in a fluid under gravity, surfaces of equal pressure are also surfaces of equal density.

*PROPOSITION 15. *When two fluids which do not mix are in stable equilibrium, the upper fluid must be lighter than the lower.*

To prove this, imagine a closed tube filled with the two fluids, and having a stop-cock at the bottom by which it can be divided into two parts. If it be possible, let the heavier fluid fill the upper part of the tube. Then there will be equilibrium so long as the surfaces of separation A, B , Fig. 38, in the two branches of the tube are at the same level. Let the fluids now be displaced so that the surfaces of separation take the positions C, D , and suppose the stop-cock

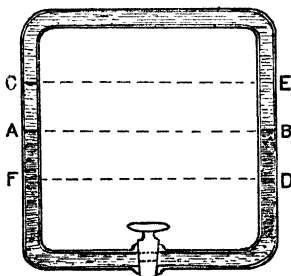

Fig. 38.

closed. Draw CE , DF horizontal to meet the fluid again in E and F . Let ω_1 , ω_2 be the weights of unit volume of the upper and lower fluids respectively, and let h be the vertical distance between DF and EC .

Then, since C and E are points in the same fluid at the same level, the fluid pressures at these two points are equal. Let each be p . Let p_1 be the pressure at D , p_2 that at F .

Then, since the vertical distances CF and DE are equal, while the density of the fluid in DE is greater than that in FC , and the pressures at C and E are equal, the pressure at D is greater than that at F .

$$\text{For we have} \quad p_1 = p + \omega_1 h,$$

$$p_2 = p + \omega_2 h,$$

and ω_1 is greater than ω_2 ; hence p_1 is greater than p_2 .

Now let the stop-cock be opened, then F and D are points at the same level in the same fluid; hence, for equilibrium, the pressure at these two points must be the same; but we have shewn that the pressure at D is greater than that at F , hence the equilibrium cannot be maintained and the column CE of the fluid will move. Moreover the surface C will ascend and E will descend; thus, if the two fluids be slightly disturbed from their original position, motion will be set up in such a way that the disturbance goes on increasing; the heavier fluid comes to the bottom, the original position was unstable.

If the lighter fluid had been at the top originally, then the same method of proof would have shewn that when the disturbance took place the pressure at D would be less than that at F , thus the column FD would, when the stop-cock is opened, move back to its original position; the equilibrium would be stable.

The proof will apply to a more general case when the two fluids instead of being contained in a tube are placed one above the other in an open vessel.

*43. Equilibrium of Two or more Fluids.

The proposition may be illustrated in various ways; if oil and water, which do not mix, be placed together in a beaker,

the oil rises to the top and floats on the water; it is lighter than the water, and the stable position of equilibrium is one with the oil on the top. It is possible, however, to arrange that the water should be above the oil.

Thus, take two small tumblers or wine-glasses of the same diameter, fill the one with water, the other with oil. Cover the top of the former with a thin card and invert it, holding the card so that no liquid escapes. Place it mouth downwards above the vessel containing the oil, the card separating the two liquids; on shifting or removing the card, so as to open a communication between the two, the oil will gradually rise into the upper vessel and the water sink into the lower one; the initial position with the water uppermost is unstable, and hence the transference occurs.

EXAMPLES.

1. Assuming the atmospheric pressure to be 1 kilo. wt. per square centimetre, find the pressure in water at the following depths:

25 cm., 1 metre, 1 mile, 5 kilometres;
and in mercury at the following depths:

1 cm., 1 metre, 25 metres, 1 kilometre.

2. The pressure at a certain point in a vessel of salt water is 35 lbs. wt. per square inch. Find the depth of the point, assuming the atmospheric pressure to be 15 lbs. wt. per square inch.

3. Determine the height of the mercury column which would produce the pressure given in Question 2.

4. Compare the pressures at equal depths in alcohol, carbon disulphide and water, neglecting the atmospheric pressure.

5. What head (1) of water, (2) of mercury is equivalent to a pressure of 14.5 lb. per square inch?

6. If the head of water above a point be 100 yards, what is the pressure at the point?

7. Find the heads (1) of water, (2) of mercury corresponding to pressures of 1 kilo wt. per square centimetre; 30 lbs. wt. per square inch; one million dynes per square centimetre.

8. Find the pressure in poundals per square foot due to a head of 30 inches of mercury.

9. What is the pressure at a depth of 60 fathoms below the surface in sea water?

10. A cylinder 3 feet in diameter is fitted with a piston and filled with water. A weight of 5 tons weight is placed on the piston, find the pressure in the water.

11. The head of water in a pipe communicating with a cylinder having a piston 2 feet in diameter is 200 feet. Find the force the piston can exert.

12. The pistons of a press are 2 inches and 10 inches in diameter; what is the pressure in the liquid when the small piston carries a load of 5 cwt. and what force can the large piston exert?

13. The pressure in a liquid at a depth of 60 inches is 30 lbs. per square inch; what is the thrust at a depth of 30 feet (1) on a square foot, (2) on a square yard?

14. The pressure in a well at a depth of 95 feet is four times that at the surface; find the pressure of the atmosphere per square inch of the surface.

15. Assuming the atmospheric pressure to be 1 kilo wt. per square centimetre, find the pressures at depths (1) of 76 cm., (2) of 380 cm. below the surface of mercury.

16. The pressure in a water-pipe at the base of a building is 40 lbs. wt. per square inch, on the roof it is 20 lbs. wt. per square inch; find the height of the roof.

17. A vessel in the form of a cube 1 metre in edge is filled with water; find the resultant thrust on its base.

18. What volume of mercury must be placed in the vessel to produce the same resultant thrust?

19. Express the pressure of the atmosphere in pounds weight per square foot when the height of the water barometer is 32 feet.

20. A vessel is partly filled with water and then olive oil is poured on until it forms a layer 6 inches deep; find the pressure per square inch at a point 8.5 inches below the surface of the oil, neglecting the atmospheric pressure.

21. A tube 20 feet long with one end open is filled with water and inverted over a vessel of water; what is the pressure in the water at the top of the column? The height of the water barometer is 33 ft.

22. A vertical tube is fixed alongside of a vessel and communicates with its bottom. The vessel contains mercury, water and olive oil, the depth of each being 10 inches. How high is the column of mercury in the tube?

23. Describe how the pressure at a point 12 inches below the surface of the water in a vessel may be measured by experiment, and how the experiment may be varied to shew on what this pressure depends.

24. The atmospheric pressure at the surface of a lake is 15 lbs. per square inch. Find at what depth the pressure is 45 lbs. per square inch, the weight of a cubic foot of water being taken to be 1000 ounces.

25. Describe an experiment to shew that the difference between the pressures at two points in a fluid at rest under gravity is proportional to the difference in their depths.

26. What will be the thrust on a square board whose side is 1 foot when sunk in water to the depth of 20 feet, the board being horizontal and the height of the barometer at the surface of the water 30 inches? The specific gravity of mercury is 13.59.

27. What is the pressure in lbs. per square inch at a point in mercury at a depth of 2 feet, the specific gravity of mercury being 13.59? The pressure of the atmosphere being neglected.

28. A layer of oil 25 cm. in depth and of specific gravity 0.82 floats on a quantity of water at the same depth. Find the difference between the pressure at the top surface of the oil and that at the bottom of the water.

29. A vertical cylinder is fitted with a smooth piston resting on water contained in the cylinder: from the side of the cylinder close to its base rises a vertical tube communicating with the cylinder, and therefore also containing water. Find the area of the piston so that for each pound placed upon it, the surface of the water in the tube may increase its vertical distance from the piston by 1 inch. [A cubic foot of water weighs 1000 ounces.]

30. A cylindrical barrel, the area of whose bottom inside the barrel is 5 square feet, has its axis vertical. A vertical pipe (area of its internal section 18 sq. inches) is screwed into a hole in the top of the barrel, and water poured in until the barrel is full, and also 7 inches of the pipe above the barrel. The uniform thickness of the top being 1 inch, find (i) the upward thrust of the water on the top of the barrel, (ii) what extra volume of water must be poured in, so that the upward thrust may be doubled? [A cubic foot of water weighs 1000 ounces.]

CHAPTER IV.

FLUID THRUST. CENTRE OF PRESSURE.

44. Thrust on a Horizontal Surface.

A value has already been found for the resultant thrust on a horizontal surface exposed to fluid pressure

It is, if we omit the pressure on the free surface of the fluid, the weight of a column of the fluid having the horizontal surface for its base and the depth of that surface for its height. This follows from the expression found in Section 35, for, if A be the area and p the pressure at each point of the area, then, since the pressure is uniform, the resultant thrust P is given by the equation

$$P = Ap.$$

But if h is the height of the surface, and ω the weight of unit of volume of the fluid, then $p = \omega h$.

Hence
$$P = A\omega h = \omega Ah.$$

Now Ah is the volume of a cylinder, having the surface for its base, and the depth of the surface for its height, and ωAh is the weight of this cylinder if composed of the fluid.

The same result can be obtained by the graphical construction given in Section 22. We have seen there that the thrust on any small area may be represented by the weight of a small cylinder having the area for its base, and the depth of the area for its height.

Imagine now that the given surface is divided into a number of small areas and that such cylinders are drawn for each. These cylinders will all be of the same height; they will form a column with a flat top having the surface for its base; the height of the column gives the pressure at each point of the base; the weight of the column will be the total thrust on the surface.

If the column be of water, its weight in grammes is measured by its volume in cubic centimetres. Thus, to find the thrust, we require to calculate the volume of the column, which is done by multiplying the area of its base by its height.

45. Thrust on a Vertical Surface.

A similar method can be applied to find the thrust when the pressure is variable. For, in this case, if the pressure be p , the thrust on any very small area a is pa . Suppose now that the surface be placed in a horizontal position. Imagine it to be divided up into a very large number of small portions, each of area a . Suppose that on each of these a column of water be erected, in such a way that the height of the column in centimetres may be equal to the pressure p in grammes weight per square centimetre; the weight of a column will be pa grammes weight, and will measure the thrust on its base.

Hence the total weight of water above the surface is equal to the thrust, as in the previous case; since, however, the pressure is variable, the heights of the various columns are different, the tops of the columns no longer lie in a horizontal plane; if, however, the area a of each column be very small and if the pressure varies gradually from point to point, the tops of the columns will lie on a smooth surface; the volume of water bounded by this surface, the horizontal base and a series of vertical lines drawn from all points on the perimeter of the base can sometimes be found, and hence the total thrust can be found.

The direction of this total thrust passes through the centre of gravity of the volume of liquid, the point of the surface at which it acts is found therefore by drawing a line at right angles to the surface from the centre of gravity of the liquid. The point thus determined is known as the centre of pressure of the surface; its position can be found in various ways (see Section 46).

Example. A rectangular plane surface is subject to fluid pressure. The pressure at any point is proportional to the distance of that point from one edge of the surface, find the thrust on the surface.

Let $ABCD$, Fig. 39, represent the surface, and suppose the pressure at any point to be proportional to the distance of the point from the side AB .

Divide the surface up into a series of narrow strips by lines parallel to AB . Let PQ be one of these strips, all points on such a strip are equidistant from AB , and hence the pressure at all such points is the same. The pressure at any point on the strip PQ will be proportional to the distance AP . Let it be $k \cdot AP$ where k is a constant, and let α be the breadth of the strip.

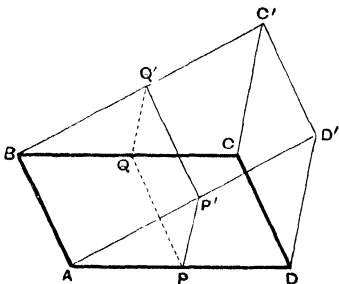

Fig. 39.

Draw PP' at right angles to the surface and equal to $k \cdot AP$ and imagine a narrow vertical column of water of height PP' to rest on PQ . The weight of this column measures the thrust on PQ . Construct similar columns on the other strips into which the surface is divided; then, since the height of each column is proportional to the distance of its base from AB , the tops of the columns lie in a plane through AB , and when the breadth of each strip is made very narrow the volume of water whose weight represents the thrust will be bounded by the horizontal plane $ABCD$, by a second plane $ABC'D'$ through AB and by vertical planes through the lines AD , DC and CB .

The volume of this mass of water will be found by multiplying together the area of the triangle ADD' , and the distance AB . The area of the triangle is

$$\frac{1}{2}AD \cdot DD'.$$

But $DD' = k \cdot AD$. Thus the area of the triangle is $\frac{1}{2}k \cdot AD^2$. Hence the volume of the water is

$$\frac{1}{2}k \cdot AD^2 \cdot AB.$$

If this volume be measured in cubic centimetres it will give the thrust on the plane $ABCD$ in grammes weight.

The question is really that of finding the thrust on a rectangular lock-gate, one side of which, AB , is in the surface of the fluid, when the effect of the atmospheric pressure is omitted; AD measures the depth of the gate and $AD^2 \cdot AB$ will be the area of the gate multiplied by its depth; if the liquid be water and the distances be measured in centimetres then k is unity.

Hence in these circumstances the thrust on a lock-gate in grammes weight is found by multiplying its area in square centimetres by half its depth in centimetres. Now the depth of the centre of gravity of the gate is half the depth of the gate. Hence in this case the thrust is the weight

of a column of the fluid whose base is the area under thrust, and height is the depth of the centre of gravity of that area. This result is a general one.

PROPOSITION 16. *To shew that the resultant thrust on any plane surface under fluid pressure is equal to the weight of a column of the fluid whose base is the area of the surface and whose height is the depth of the centre of gravity of the surface.*

Let the surface be divided into a number of elements, so small that we may treat the pressure as uniform over each.

Let a be the area of one of these elements, p the pressure at any point of this element, and let z be the depth¹ of the element below the surface, ω the weight of a unit of volume of the fluid.

The thrust on the area a is pa .

Since the surface is plane the thrusts on the various elements are all parallel; the resultant thrust is therefore the sum of the thrusts on the various elements.

Hence, if P be the resultant thrust, a_1, a_2, \dots the areas of the various elements, then

$$\begin{aligned} P &= p_1 a_1 + p_2 a_2 + \dots \\ &= \Sigma (pa). \end{aligned}$$

But

$$p_1 = \omega z_1, \quad p_2 = \omega z_2, \dots$$

Therefore

$$\begin{aligned} P &= \omega z_1 a_1 + \omega z_2 a_2 + \dots \\ &= \omega \{z_1 a_1 + z_2 a_2 + \dots\} \\ &= \omega \Sigma (za). \end{aligned}$$

Now (*Statics*, § 38) we know that if \bar{z} is the depth of the centre of gravity of a number of particles a_1, a_2, \dots then

$$\bar{z} = \frac{a_1 z_1 + a_2 z_2 + \dots}{a_1 + a_2 + \dots} = \frac{\Sigma(za)}{\Sigma(a)}.$$

And in the case in point,

$$\Sigma(a) = \text{area of surface} = A.$$

Hence

$$A\bar{z} = \Sigma(za).$$

Hence

$$P = \omega \Sigma(za) = \omega A\bar{z}.$$

¹ If the pressure on the upper surface of the fluid is to be considered s must be measured from the effective surface, see Section 32.

Again, $A\bar{z}$ is a volume of fluid having the area A for its base and \bar{z} , the depth of the centre of gravity, for its height; while $\omega A\bar{z}$ is the weight of this volume. Thus the Proposition is proved.

Corollary. (i) The resultant thrust on a given plane surface does not depend on the inclination of the surface to the horizon, but solely upon its area and the depth of its centre of gravity. Thus, if the centre of gravity be fixed, the inclination of the surface to the horizon may be altered without altering the resultant thrust.

(ii) The resultant thrust does not depend upon the shape of the surface, but only upon its area, so long as the centre of gravity remains fixed in position; thus a plane surface of any shape, having a given area and its centre of gravity at a given depth, is subject to the same resultant thrust when immersed in a fluid.

46. Centre of Pressure.

DEFINITION. *The Centre of Pressure of any plane surface exposed to fluid pressure is the point of the surface at which the resultant thrust acts.*

Since the directions, in which the fluid pressure acts at each point of a plane surface, are parallel; the centre of pressure will be the point of application of the resultant of a system of parallel forces representing the thrusts on the elements of the surface; its position can therefore be found¹ by an application of the laws for determining the position of the resultant of a number of parallel forces.

In a few simple cases it is readily obtained by an application of the graphic method of Sections 22 and 45.

***PROPOSITION 17.** *To find the centre of pressure of a rectangle with one side in the surface of the fluid.*

Let $ABCD$ be the rectangle, the side AB being in the surface of the fluid. The pressure at any point of the rectangle is proportional to the depth of the point; thus, if we divide the rectangle into a number of horizontal strips, the pressure is the same at each point of any given strip.

¹ Greaves, *Elementary Hydrostatics*, Chapter iv.

Draw CE and DF at right angles to the surface of the rectangle to represent the pressures at C and D , and join AF , FE , EB . Then, it follows from the graphical construction,

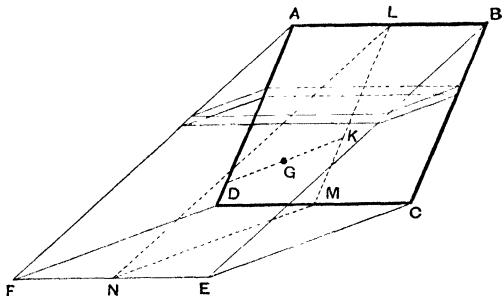

Fig. 40.

that the thrust on any element is represented by a column of the fluid bounded by lines drawn at right angles to the surface of the element to meet the plane $AFEB$; the resultant thrust is the weight of the wedge of fluid between the rectangle and $AFEB$, and acts, at right angles to the rectangle, through the centre of gravity of the wedge.

Now the wedge can be divided by planes parallel to BEC into a series of equal triangular laminae, its centre of gravity therefore coincides with that of the triangle LMN , in which the wedge is cut by a vertical plane midway between AFD and BEC .

Let G be the centre of gravity and draw GK perpendicular to the plane of the rectangle. Then, since G is two-thirds of the way down the line joining L to the middle point of MN , it follows that LK is two-thirds of LM .

Thus, *The centre of pressure of the rectangle, with one side AB in the surface of a fluid, is a point at two-thirds of the depth of the bottom of the rectangle, midway between the sides AD and BC .*

Hence, if it were desired to balance the fluid pressure on one face of the rectangle by a single force, this force must be applied at the point K just found.

*PROPOSITION 18. *To find the centre of pressure of a triangle with one side in the surface of the fluid.*

Consider a triangle ABC , Fig. 41, with one side BC in the surface. Let AD , drawn at right angles to the triangle, represent the pressure at the point A . Join BD , DC ; then the weight of the tetrahedron $ABCD$ represents the thrust on the triangle; this thrust acts at right angles to the plane ABC , through G , the centre of gravity of the tetrahedron. Let AM bisect the base BC

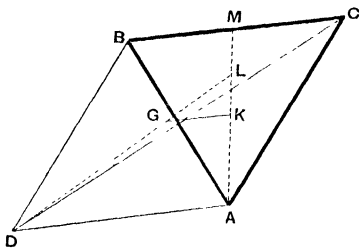

Fig. 41.

in M . Join DG and produce it to meet the triangle ABC in L , and let GK , drawn perpendicular to the triangle, meet it in K . Then K is the centre of pressure required. Moreover it is known from the properties of the tetrahedron that L is the centre of gravity of the triangle and that K and L both lie on the line AM .

Also $DG = \frac{3}{4} LD$
and $AL = \frac{2}{3} AM$.

Hence, since AD and GK are parallel,

$$AK = \frac{3}{4} AL = \frac{3}{4} \times \frac{2}{3} \cdot AM \\ = \frac{1}{2} AM.$$

Thus, *The centre of pressure of a triangle with its base in the surface of a fluid is situated on the line from the vertex bisecting the base and at half the depth of the vertex.*

*PROPOSITION 19. *To find the centre of pressure of a triangle with one angular point in the surface of the fluid and its base horizontal.*

Let ABC , Fig. 42, be the triangle. Draw BD and CE at right angles to its plane, to represent the pressures at B and C . Join AD , AE and DE . Then the thrust on the triangle is the weight of the tetrahedron $ABCED$ acting at right angles to ABC through G , its centre of gravity.

Let GK be perpendicular on ABC ; let L be the middle point of BC and M the centre of gravity of the base $BDEC$.

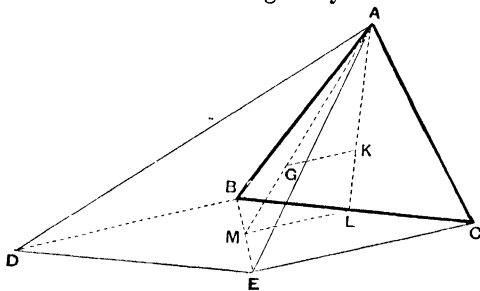

Fig. 42.

Then AGM and AKL are both straight lines, and AG is $\frac{3}{4}$ of AM .

Hence, since GK and ML are parallel, $AK = \frac{3}{4}AL$.

Thus, *If a triangle have its vertex in the surface and its base horizontal, the centre of pressure is on the line joining the vertex to the middle point of the base and at three-fourths the depth of this middle point.*

47. Thrust on the base of a vessel.

The expressions which have been found for the thrust on a plane surface exposed to uniform fluid pressure will apply to the case of liquid in a vessel with a flat bottom. It follows hence that

The Resultant Thrust on the plane base of a vessel containing fluid does not depend on the shape of the rest of the vessel, but only on the area of the base and on the depth of the liquid.

Thus in Fig. 43, (i), (ii), (iii) represent three vessels, the bases of which are equal in area. In (i) the sides are vertical, in (ii) they lean outwards so that the vessel is wider at the

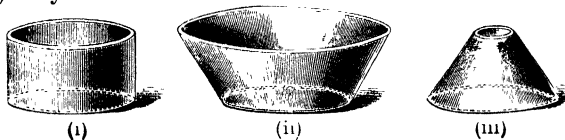

Fig. 43.

top than at the bottom, in (iii) they lean inwards so that the reverse is the case. The depth of water in each vessel is the same. Under these circumstances the thrust on the bottom of each vessel is the same.

The pressure at each point of the base is the same; the thrust on any portion of the base is the weight of a column of liquid obtained by drawing vertical lines from all points of the boundary of that portion up to the level of the surface of the liquid. In (i) and (ii) such lines will lie wholly within the liquid. If the depth of the liquid be d centimetres there actually is a column of height d above any portion of the base.

For some parts of the vessel (iii) vertical lines drawn from the base will cut the sides. A column of liquid of height d does not exist above the whole of the base; the thrust on the bottom however is the same as though it did exist. Thus in Fig. 44, MNL represents a column cutting the side of the vessel in N , and CD the upper surface of the liquid produced in M .

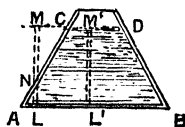

Fig. 44.

Then the thrust on the area of the base at L , on which the column stands, is the weight of the column ML , not that of NL . To prove this let L' be another point on the base from which a column $M'L'$ can be drawn to reach the surface CD in M' ; then the pressure at L is equal to the pressure at L' since LL' is horizontal.

But the pressure at L' is the weight of a column of height $M'L'$ and unit cross section. Hence the pressure at L is the weight of a column of unit cross section and of height $M'L'$, which is equal to ML .

It sometimes appears paradoxical that the vertical thrust on any surface should be greater than the weight of the column of fluid immediately above it. In the case, however, of a column such as NL the fluid at N exerts an upward thrust on the surface at N ; it is shewn, Section 48, that the vertical component of this thrust is the weight of the column MN , thus the surface of the vessel at N exerts a downward thrust on the top of the column NL whose vertical component is the weight of NM . This downward vertical thrust transmitted through the liquid together with the weight of the column NL , make up the resultant downward thrust on the base of the column at L , which is equal therefore to the weight of the column ML .

The Resultant downward Thrust, on the base is found in all cases by drawing vertical lines from all points of the boundary of the base to meet the surface or surface produced, and is the weight of the column so formed.

In Fig. 43 (i) this is equal to the weight of the liquid in the vessel; in (ii) the liquid extends outside the column, the thrust is less than the weight of liquid; in (iii) the column extends outside the liquid, the resultant vertical thrust is greater than the weight of the liquid. In all three cases if the areas of the bases and the depths of liquid be the same the resultant thrusts are equal.

In (i) the thrusts due to the sides of the vessel are entirely horizontal and do not affect the vertical thrust or help to support the liquid; in (ii) the thrusts due to the sides have an upward component, the weight of the liquid is in part supported by them; in (iii) the thrusts due to the sides act downwards and increase the thrust on the base beyond the weight of the contained liquid.

It should be clearly remembered in the above that we are dealing with the thrust on the base of the vessel containing the liquid, the force on the table on which the vessel stands is in all cases of course equal to the weight of the vessel together with the weight of the liquid.

In (ii) the downward thrust due to the weight of liquid above the sloping sides is transmitted through the sides to the supports carrying the vessel; the sides are forced more close to the base of the vessel.

In (iii) the upward thrust on the curved sides is transmitted through the sides to the base and just balances the excess of the downward thrust over the weight of the contained liquid; in (ii) the thrust on the sides would tend to close a small leak at the junction of the sides and the base; in (iii) it would tend to open such a leak.

EXPERIMENT 10. *To shew that the thrust on the base of a vessel filled with liquid depends only on the area of the base and on the depth of the liquid and not on the shape of the vessel.*

This is usually verified by an experiment due to Pascal and known as Pascal's Vases, Fig. 45. A number of vessels (or vases) differing in form can be screwed on to a stand. Each vessel is open at its base, and the area of the aperture is the same in each. When on the stand the vessels are closed

below by a moveable piece which is attached to one arm of a lever or balance. The other arm of the balance carries a scale-

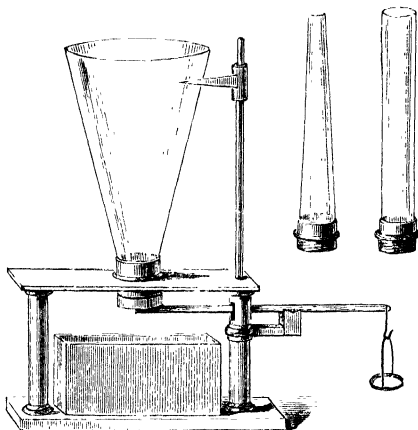

Fig. 45.

pan, into which weights can be placed. One of the vases is screwed on to the stand and weights are placed in the scale-pan. Water is then poured into the vessel until it just begins to raise the scale-pan and escape at the bottom; the level of the water is then noted by means of the pointer attached to the apparatus; the vessel is then removed and replaced by one of the others and the experiment is repeated; it is found that the scale-pan is again raised, and the water begins to escape when the level is the same as before.

Thus the thrust on the base depends on the depth of the water, and not on the shape of the vessel.

The experiment may be performed with more simple apparatus in the following manner:—

The end of a glass cylinder is ground flat and closed by a piece of flat glass supported by a string from the arm of a balance, the cylinder being held in a suitable stand. Weights are placed in the other pan and water poured in until it just begins to escape. The cylinder is then replaced by a glass tube

of different shape, a lamp chimney for example, having the same area of cross section, and the experiment is repeated. Instead of using a second vessel the cylinder may be closed some way below its top by a cork. A narrow glass tube is inserted through the cork projecting well above it and the water is poured through this tube, through which also passes the string carrying the plate, it is found that when the water escapes the level in the narrow tube is the same as it was previously in the cylinder.

In any of the above experiments however there is some difficulty in making the bottom fit sufficiently well to the various vessels to prevent leakage until the thrust reaches the proper amount.

48. Vertical thrust on a curved surface.

Hitherto we have been dealing with *plane* surfaces exposed to fluid pressure; in such a case the direction of the thrust is the same at all points of the surface, we have a system of parallel forces, and these have a resultant—the total thrust on the surface—which acts at right angles to the surface.

If we come to consider a curved surface the problem is more complex. The direction of the pressure is different at the various points of the surface; the thrusts therefore do not constitute a system of parallel forces and their resultant is more difficult to calculate. We may however resolve the thrust on each element of the surface into horizontal and vertical components, and calculate the resultant horizontal and vertical thrusts thus.

PROPOSITION 20. *To find the resultant vertical thrust on a surface exposed to fluid pressure.*

Let AB , Fig. 46, be such a surface and suppose we wish to

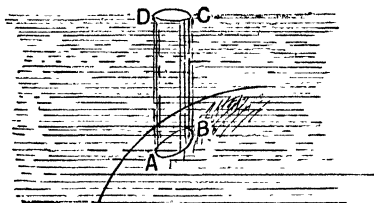

Fig. 46.

find the resultant vertical thrust on its upper side. From each point of the boundary of AB draw vertical lines to the surface, and consider the column of fluid $ABCD$ thus formed. It is in equilibrium under its own weight, the downward thrust on its upper surface, the thrust over the surface AB and the thrusts due to the surrounding portions of the fluid acting on its vertical faces.

Now these last are all horizontal. Thus the vertical component of the thrust due to AB , together with the thrust on the top surface, must balance the weight of the column of fluid.

$$\begin{aligned} \text{Hence, Vertical component of thrust on } AB \\ &= \text{weight of column } ABCD \\ &+ \text{thrust on upper surface } CD. \end{aligned}$$

This result has been proved for the upper side of AB . If however the liquid is below AB , the upward thrust on the lower side of AB is equal and opposite to the downward thrust on the upper side of AB .

Hence the upward vertical thrust on the lower side of AB is equal to the weight of $ABCD$ together with the vertical thrust on CD .

In many problems we are not concerned with the effects of the thrust on the free surface of the liquid. In this case the vertical thrust acts through the centre of gravity of the column $ABCD$, and is equal to the weight of that column.

It may happen that the surface on which the thrust is required has a form such as ABC in Fig. 47.

Let B be a point at which the tangent to the surface is vertical, then the downward vertical thrust on AB and the upward vertical thrust on BC can both be calculated, the vertical thrust on ABC is the resultant of these two and is thus found.

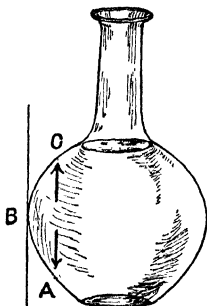

Fig. 47.

49. Horizontal thrust on a curved surface.

PROPOSITION 21. *To find the resultant thrust in a given horizontal direction on a surface exposed to fluid pressure.*

Let AB , Fig. 48, be the surface. Draw lines from all points of the boundary of AB in the given horizontal direction. Let these lines cut in CD a vertical plane perpendicular to the given direction, and consider the equilibrium of the horizontal column of fluid thus formed.

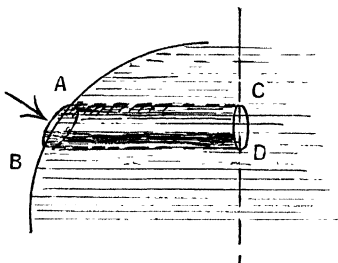

Fig. 48.

It is acted on by its weight, the thrust on AB , the thrust on CD , and the thrusts on its curved surface; these last thrusts are all at right angles to the lines bounding the column. The only forces then in the given direction, perpendicular that is to CD , are the thrust on CD , and the component, perpendicular to CD , of the thrust on AB . These two forces then must balance. Now it is this last component we desire to find.

Thus we see that the horizontal component, in the given direction, of the thrust on AB is equal to the thrust on CD .

This latter thrust has been shewn in Proposition 16 to be equal to the weight of a column of fluid having CD for its base and the depth of the centre of gravity of CD for its height; its direction passes through the centre of pressure of CD .

Thus when the thrust on CD can be found the component, in the required direction, of the thrust on AB is known.

EXAMPLES.

[For a Table of Specific Gravities see page 15.]

1. Shew that the force on the horizontal base of a vessel containing fluid does not depend on the shape of the vessel.

2. Determine the thrusts (*a*) on a square foot, (*b*) on a square mile of the earth's surface after the fall of .95 inches of rain.

3. A conical vessel 10 inches high on a flat circular base 5 inches in radius is filled with water. Compare the vertical thrust on the base when the vertex is upwards with the vertical thrust on the curved surface when it is downwards.

4. A hollow cube with its base horizontal is filled with water, shew that the resultant thrust on each vertical face is half that on the base.

5. A hollow cylinder, whose section is a square 1 foot in edge, is filled with water. Find its depth if the thrust on each face is equal to that on the base, the height of the water barometer being 30 feet.

6. A closed cubical cistern is filled with water and communicates through a pipe with a second cubical cistern of eight times the volume. The second cistern is open and its surface is 30 feet above the base of the first. Compare the thrusts (*a*) on the bases, (*b*) on the vertical sides of the two, assuming the height of the water barometer to be 30 feet.

7. A tank in the form of a cube whose edge is 1 foot is half filled with water, half with olive oil. Find the thrust on a vertical face.

8. Find the thrust on a rectangular plate 12×8 inches immersed vertically in mercury with the short edge on the surface.

9. One of the vertical faces of a cubical tank 3 feet in edge is hinged about its upper edge. The tank is filled with water. What is the least force which must be applied to the face to retain it in its vertical position, and where must this force act?

10. The base of a rectangular tank the upper edges of which are 2 feet and 5 feet in length respectively is inclined so that when the tank is full it is 4 feet deep at one edge, 2 feet at the opposite edge. Find the resultant force on the base.

11. A tank 9 feet deep and 20 feet long is full of water; what is the total thrust on one side of the tank?

12. A rectangular tank is 12 feet long, 7 feet wide, and $2\frac{1}{2}$ feet deep; compare the thrusts on a side and on the bottom of the tank.

13. Shew how the pressure in a fluid varies with the depth; and find the resultant thrust on a fifty-foot length of the vertical retaining wall of a water reservoir 15 feet deep.

14. Determine the total thrust on one side of a rectangular vertical dock-gate 50 feet wide immersed in salt water to a depth of 25 feet, having given that a cubic foot of fresh water weighs 1000 ounces and that the specific gravity of sea water is 1.026.

15. The water on one side of the dock-gate in the previous question is fresh. What is its depth if the resultant thrusts on the two sides are equal?

16. An equilateral triangle is immersed in water, two of its angles being at a depth of 6 feet and the third at a depth of 9 feet. Find the force due to the water pressure on one side of the triangle.

17. A closed cubical cistern, each edge of which is 4 feet, is filled with water, and has a vertical pipe 10 feet high in its upper surface opening into it, also filled with water; if the atmospheric pressure be 14 lbs. per square inch, find the whole thrust on the base of the cistern.

18. A rectangular-shaped box is constructed with its ends (weightless) hinged to the base and capable of moving without friction between the sides, but so as to enable the box to contain water. The tops of these equal rectangular ends are connected by a piece of inelastic string so that, when water is poured into the box, they are inclined inwards and make equal angles with the vertical. Shew that the tension of the string varies as the cube of the depth of the water.

19. A tall conical champagne glass, the area of whose mouth is 2 square inches, is filled with wine of specific gravity = 1.296, and the top is covered with a glass disc. The whole is then inverted and placed on a horizontal table so that no wine is spilt. If the weight of the champagne glass be just sufficient to prevent the wine from escaping, shew that the weight of the glass in ounces is equal to the depth of its conical contents in inches. [The volume of a cone is *one-third* of the volume of the cylinder with the same base and height.]

20. A vessel in the form of a portion of a cone is closed top and bottom by two circular plates, one being 3 inches and the other 5 inches in diameter, and filled with fluid. Compare the forces on the lower plate (1) when the larger one, (2) when the smaller one is at the bottom, and explain how it is that in the one case the pressure is greater and in the other less than the weight of the fluid.

CHAPTER V.

FLOATING BODIES.

50. Resultant vertical thrust on a body totally immersed.

In a previous Section (see Section 48) we have considered the resultant vertical thrust on any surface. When the body, whose surface is under consideration, is totally immersed a simpler expression can be found for the resultant thrust.

Let us consider in the first case a cylinder $ABCD$, Fig. 49, immersed with its axis vertical and its ends horizontal; the curved surface is then vertical; thus the pressure at each

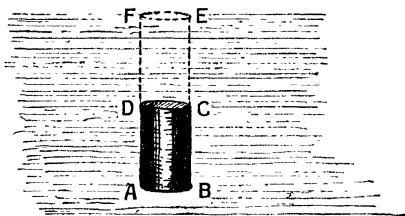

Fig. 49.

point of this surface is horizontal and cannot contribute to the vertical thrust.

Produce the vertical surface of the cylinder to meet the free surface of the liquid in EF . The resultant vertical thrust is the difference between the upward thrust on the bottom AB , and the downward thrust on the top CD . The upward thrust is equal to the weight of the column $ABEF$ together with the thrust on EF , the downward thrust is the weight of the column $CDFE$ together with the thrust on EF .

The difference between the two is the weight of a column $ABCD$, and acts upward through the centre of gravity of $ABCD$. Thus in this case the resultant vertical thrust on the cylinder is equal to the weight of the fluid displaced by the cylinder.

We shall shew in the next section that this result is true whatever be the shape of the body. We will however consider first another simple case. Let ABC , Fig. 50, be a body of spherical, or egg-shaped, form immersed in a fluid.

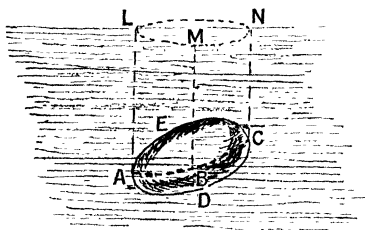

Fig. 50.

Imagine a vertical line AL to be drawn touching the body, and let this line move round the body always touching it, and always retaining its vertical position. It will thus trace out a cylindrical surface¹ touching the body in a curve ABC , and cutting the surface in a curve LMN .

The curve ABC divides the body into two parts; over the lower part $ABCD$ the vertical pressure is everywhere upwards, the resultant vertical thrust on this part of the surface will thus be an upward force tending to raise the body, and it will be equal to the weight of the column of fluid $LADB$. At points on the surface above ABC the pressure acts downwards, the resultant vertical thrust is thus downwards and is equal to the weight of the column $LAEBM$. The resultant vertical thrust on the whole body is the difference between these two and is equal to the difference between the weights of these two columns. This difference is the weight of the volume of fluid displaced by the body.

¹ We may imagine such a surface formed by rolling a sheet of paper so as to touch the body along a continuous curve.

The above method of proving this result, known as Archimedes' Principle, could be extended to more complex cases in which it was not possible to surround the body with a single vertical cylinder as in figure 50. The following proof will however apply to any case.

PROPOSITION 22. *To prove Archimedes' Principle, viz. that the resultant thrust on any body immersed in a fluid is equal to the weight of fluid displaced and acts vertically upwards through the centre of gravity of the fluid displaced.*

Let S , Fig. 51, be a body immersed in a fluid and held in position if necessary.

The fluid pressure at any point of the surface of S depends only on the depth of the point, and not on the nature of the surface on which the pressure acts. Imagine the body S to be removed, and the space it occupied filled

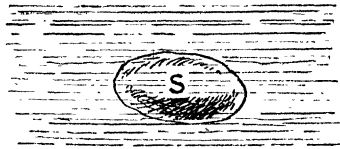

Fig. 51.

with a quantity of the fluid, the rest of the fluid being undisturbed. The pressure at each point of the surface of this additional fluid is unaltered, and has the same value as when the solid was in its original position. Thus the resultant thrust on the solid is the same as that on the fluid which has replaced it. Now the fluid is in equilibrium under its own weight and the resultant thrust on its surface. This resultant thrust then must be equal to the weight of the fluid and must act vertically upwards through its centre of gravity.

Thus, *The resultant thrust on a solid immersed in a fluid is equal to the weight of fluid displaced, and acts vertically upwards through the centre of gravity of this displaced fluid.*

If the solid be not completely immersed, but cut the surface as ABC in Fig. 52, we must, in the same way, replace by fluid that portion of the solid which is below the surface.

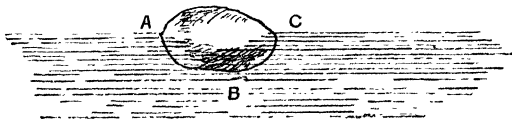

Fig. 52.

DEFINITION. *The upward resultant thrust on an immersed solid is spoken of as the Buoyancy of the Solid, the centre of gravity of the fluid displaced is the Centre of Buoyancy.*

The results of the last few Articles may be verified by experiment.

EXPERIMENT 11. *To shew that the resultant upward thrust on an immersed body is equal to the weight of fluid displaced.*

(a) Take a body of which the volume can be found by measurement, a cube or cylinder suppose, and find its volume by the use of the calipers or in some other way (*Dynamics*, § 7); let it be V cubic centimetres. Weigh it in air with a balance, let the weight be W grammes weight. Immerse it in water and weigh again. In order to weigh a body in water it is suspended below the scale-pan of a balance or else the arrangement shewn in Figure 53 (a) is adopted. A stand or bridge rests on the floor of the balance case over one of the scale-pans which can swing freely below it; the supports of the scale-pan pass on either side of the bridge; the body to be weighed is suspended from a hook attached to the knife edge which carries the scale-pan. The vessel of fluid is placed on the

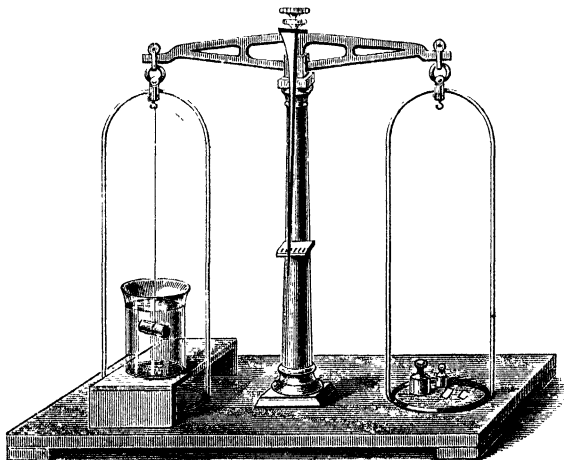

Fig. 53 a.

bridge and the body can be immersed in it. Let the weight of the body in water be W' grammes weight. The weight W' will be less than W because the body is partly supported by the fluid; the difference $W - W'$ will measure the resultant upward thrust due to the fluid. It will be found, if the fluid be water, that $W - W'$ is V grammes weight. Now we must remember that the weight of 1 c.cm. of water is 1 gramme weight, hence V c.cm. will weigh V grammes and we find thus that $W - W'$ is equal to the weight of V c.cm. of water. Hence the resultant upward thrust on the solid is equal to the weight of water displaced.

If a spring-balance graduated in pounds be used, its readings must be reduced to grammes by remembering that 1 lb. is approximately equal to 453 grammes.

(β) If the volume of the body cannot be found by direct measurement, it may be obtained by the displacement method described in *Dynamics*, Section 7, Experiment 4, and the experiment proceeded with as described above.

EXPERIMENT 12. *To determine the additional thrust on the*

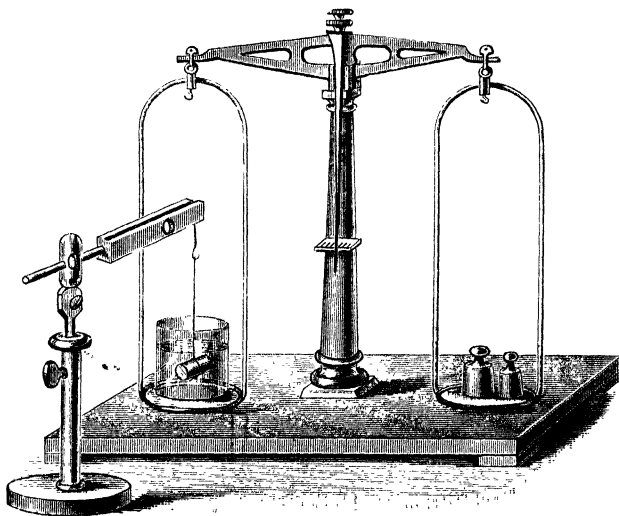

Fig. 53 b.

bottom of a vessel containing fluid produced by suspending a solid in the fluid.

This thrust must clearly be equal to the upward thrust of the fluid on the solid. To prove this, place a vessel containing water on the pan of a balance and counterpoise it. Take a body of known volume V c.cm. and suspend it in the water from a fixed support as shewn in Fig. 53 (b). The pan carrying the water is depressed; to restore equilibrium it will be found that V grammes weight must be placed in the other scale. Now this is the weight of water displaced by the solid.

The solid when placed in the water raises the level everywhere. Thus the pressure at each point of the base is increased; hence the thrust on the base is increased. Moreover if h is the rise of level and A the area of the water surface the additional thrust is the weight of a volume Ah of water. But since the level is raised by immersing the solid, Ah must be equal to the volume of the solid. Thus the additional thrust is a weight of water equal in volume to the solid.

Another experiment is the following.

EXPERIMENT 13. *To verify Archimedes' Principle for the case of a cylindrical body.*

In Fig. 53 (c) AB is a metal cylinder with a hook attached to its upper end. CD is a hollow cylinder closed at the bottom; the interior volume of this cylinder is equal to the volume of AB , so that AB can be placed inside CD and will fit it exactly. The two are suspended from one arm of a balance and counterpoised; the lower cylinder hangs inside an empty beaker. This beaker is then filled with water, the upward thrust on AB disturbs the balance and the arm carrying the cylinders rises. Water is then dropped from a pipette into the hollow cylinder CD , and its weight tends to restore the equilibrium; when CD is full it will be found that the

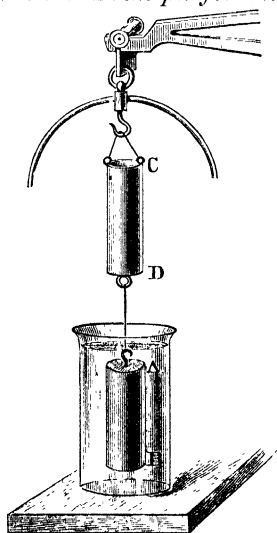

Fig. 53 (c).

balance beam is again horizontal. The upward thrust on AB is exactly balanced by the weight of water which fills CD , and the volume of this water is the same as the volume of AB ; thus the buoyancy of AB is the weight of water which it displaces.

The experiment may be performed with some liquid other than water, the liquid which fills CD and that in which AB is immersed must of course be the same.

EXPERIMENT 14. *To find the volume of a body by weighing it in air and in water.*

Archimedes' Principle gives us a means of finding the volume of any body which sinks in water. Thus weigh the body in air, let it be W grammes weight. Weigh it in water, let it be W' grammes weight. Then the buoyancy or upward thrust is $W - W'$ grammes weight, and this is the weight of a mass of water equal in volume to the body. But the volume of $W - W'$ grammes of water is $W - W'$ cubic centimetres. Thus the volume of the body is $W - W'$ cubic centimetres.

If we are weighing in pounds we must, in order to find the volume, remember that a cubic foot of water weighs 62.32 pounds. Hence the volume of 1 lb. of water is $1/62.32$ cubic feet and the volume of $W - W'$ pounds is $(W - W')/62.32$ cubic feet.

This method of finding the volume of a body is made use of in many of the experimental determinations of specific gravity. (See Chapter vi.)

51. Floating Bodies.

When a body is floating in a fluid partially immersed, the volume of liquid displaced is less than that of the body; the upward thrust is the weight of the liquid displaced, and acts vertically through the centre of gravity of the fluid displaced.

PROPOSITION 23. *To find the conditions of equilibrium of a body floating freely.*

Let ABC , Fig. 54, be the body and let G be its centre of gravity; let H be the centre of buoyancy, i.e. the centre of gravity of the fluid displaced. Then the body is in equilibrium under two vertical forces, viz. its own weight W acting

downwards at G , and the weight of fluid displaced W' , acting upwards at H . It is necessary for equilibrium that these two

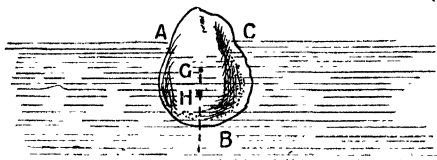

Fig. 54.

forces should be equal and opposite, for when two forces maintain a body in equilibrium they must be equal and their lines of action must lie in the same straight line. Hence the conditions of equilibrium are

(i) *The weight of the body is equal to the weight of fluid displaced.*

(ii) *The centre of gravity of the body is in the same vertical line as that of the fluid displaced.*

PROPOSITION 24. *A solid of given volume and density floats freely in a fluid of given density, to find the volume immersed.*

Let V , ρ be the volume and density of the solid, V' the volume immersed, ρ' the density of the fluid.

Then the weight of the solid is equal to the weight of fluid displaced; hence the mass of the solid is equal to the mass of fluid displaced.

But the mass of the solid is $V\rho$; the volume of fluid displaced is V' , and its density is ρ' , its mass therefore is $V'\rho'$.

$$\text{Hence} \quad V\rho = V'\rho'.$$

$$\text{Therefore} \quad V' = V \frac{\rho}{\rho'}.$$

If the fluid be water the ratio ρ/ρ' is the specific gravity of the solid. Hence, since ρ/ρ' is equal to V'/V we see that,

When a solid floats in water its specific gravity is the ratio of the volume immersed to the whole volume of the solid.

Corollary. If we can easily measure the value of V' we can use the result to compare the densities of different fluids. For we have

$$\rho' = \frac{V\rho}{V'}.$$

Now suppose the solid allowed to float in a fluid of density ρ'' , and let V'' be the volume immersed.

Then
$$\rho'' = \frac{V\rho}{V''}.$$

Hence
$$\frac{\rho'}{\rho''} = \frac{V''}{V'}.$$

Hence *The densities of two fluids in which a given solid can float are inversely as the volumes immersed.*

We can prove this more briefly thus. When the solid floats, the mass of fluid displaced is equal to that of the solid. Hence the masses of the two fluids displaced are the same, hence their densities are inversely proportional to their volumes, i.e. to the volumes of the solid immersed.

This principle is made use of in the common Hydrometer. See Section 58.

PROPOSITION 25. *To find the conditions of equilibrium of a solid immersed in a fluid and held by a string.*

(i) When the solid is totally immersed as in Fig. 55 the solid is acted on by three forces; its own weight, the buoyancy

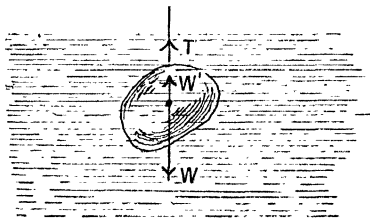

Fig. 55.

of the fluid, and the tension of the string. Since the solid is totally immersed, if we suppose it to be homogeneous, the centre of gravity of the fluid displaced coincides with that of the solid.

Thus the first two forces are vertical and act at the same point; the tension of the string is therefore vertical and its direction passes through the centre of gravity of the solid. Thus the point of attachment of the string is in the same vertical as the centre of gravity. Let W be the weight of the solid, W' that of the fluid displaced, the tension T is the difference between W and W' . If W is greater than W' the tension acts upwards, supporting the solid, and we have

$$T = W - W'.$$

In this case the solid is denser than the fluid. If W' is greater than W , or the fluid denser than the solid, then $T = W' - W$, and the string helps to keep the solid submerged.

* (ii) When the solid is not totally immersed. In this case the centre of gravity G and the centre of buoyancy H do not coincide. Let A , Fig. 56, be the point at which the

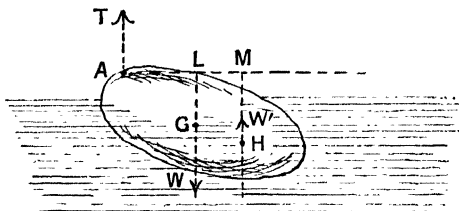

Fig. 56.

string is attached, then the forces W and W' , acting at G and H respectively, are parallel, being both vertical in direction; hence the third force T is also parallel to them, the string is vertical, and, assuming that W is greater than W' ,

$$T = W - W'.$$

Again, let ALM meet in L and M the vertical lines through G and H respectively; then taking moments about A we have

$$W \cdot AL = W' \cdot AM.$$

This equation will determine the weight of the fluid which is displaced, and then the former equation will give T .

In case (i) it has been assumed that the solid is homogeneous so that its centre of gravity coincides with that of the fluid displaced; if this is not true the methods of (ii) must be applied to (i).

52. Buoyancy of the Air.

Experiments will be described in Section 66, which prove that air has weight. When therefore a body is weighed in air it is acted on by an upward thrust equal to the weight of the air displaced.

Hence the apparent weight of a body, when weighed in air, is not its true weight. The buoyancy of the air is illustrated by the ascent of a balloon. An air-tight bag of silk or some other light material is filled with hydrogen or coal gas or some other gas of less density than air, the weight of air displaced is then greater than the weight of the balloon, which can therefore rise and draw up with it a light car carrying passengers. The necessary condition is that the weight of air displaced should be greater than that of the balloon and its load.

In a fire-balloon the gas used is heated air, this is less dense than cold air; the bag is filled over a piece of sponge or cotton wick soaked in methylated spirits and ignited.

EXPERIMENT 15. *To illustrate the buoyancy of the air.*

In Fig. 57, *A* is a glass bulb with thin walls. A portion of the tube from which the bulb was blown is left attached, as

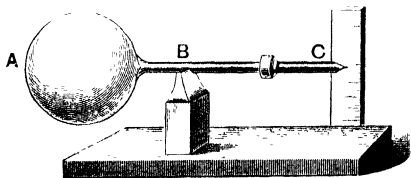

Fig. 57.

shewn at *BC*, being closed at the end *C*. By means of a small metallic counterpoise the whole is balanced with the stem horizontal on a knife edge at *B*.

The weight of air displaced by the bulb is much greater than that displaced by the tube *BC* and the counterpoise.

Since there is equilibrium, we have, taking moments round B ,

- Moment of bulb and contained air
- moment of air displaced by bulb
- = moment of counterpoise and tube
- moment of air displaced by these.

The apparatus is then put inside the receiver of an air-pump (see Section 96), and the air is exhausted. As the exhaustion proceeds the bulb A sinks while the counterpoise rises. By withdrawing the air the upward thrust due to it is diminished; the buoyancy effect on the bulb is greater than that on the counterpoise, this is shewn by the ascent of the latter.

53. Corrections for weighing in air.

The buoyancy of the air affects the result of weighings made in air and a correction is in consequence needed. The correction is very small in most cases, but it is desirable to shew how to introduce it.

***PROPOSITION 26.** *To find the correction to the apparent weight of a body due to the buoyancy of the air.*

Let M be the true mass of the body to be weighed, ρ its density; let M_0 be the mass of the weights, ρ_0 their density, and let λ be the density of the air.

The volume of the body is M/ρ and the mass of air displaced by it is $M\lambda/\rho$, the mass of air displaced by the weights is $M_0\lambda/\rho_0$.

Now if the balance be true the difference between the weight of the body and the weight of air it displaces is equal to the difference between the weight of the "weights" and the weight of air they displace; and since the weights of these various bodies are proportional respectively to their masses

$$M - M \frac{\lambda}{\rho} = M_0 - M_0 \frac{\lambda}{\rho_0}.$$

Therefore

$$M = M_0 \left(\frac{1 - \frac{\lambda}{\rho_0}}{1 - \frac{\lambda}{\rho}} \right).$$

Now the value of λ varies with the pressure and temperature of the air, it is however very small compared with the density of solids or liquids, thus λ/ρ and λ/ρ_0 are very small quantities. If then we divide by the denominator $1 - \lambda/\rho$ and neglect λ^2/ρ^2 , and higher terms which will be very small indeed, we find

$$M = M_0 \left\{ 1 - \frac{\lambda}{\rho_0} + \frac{\lambda}{\rho} \right\}.$$

For air under standard conditions λ is about $\cdot 0012$ grammes per c.cm., while ρ_0 for brass weights it is about 8 grammes per c.cm., thus λ/ρ_0 is about $\cdot 00015$.

The value of λ/ρ depends on the density of the body weighed: for water ρ is 1 gramme per c.cm. and λ/ρ is $\cdot 0012$.

Thus the true mass M of a volume of water weighed with brass weights is given in terms of the apparent mass M_0 by the formula

$$\begin{aligned} M &= M_0 (1 - \cdot 00015 + \cdot 0012) \\ &= M_0 (1 + \cdot 00105). \end{aligned}$$

The correction in this case amounts to about $\cdot 1$ per cent.

54. Experiments on floating bodies.

The following experiments illustrate some of the laws of floating bodies.

(i) The mass of an egg is greater than that of an equal volume of fresh water, it is less than that of an equal volume of a strong solution of salt in water; thus an egg will sink if placed in fresh water, it will float if placed in a strong solution of salt in water.

If a vessel is half filled with salt solution and then fresh water is carefully poured on to the top, the two liquids mix where they come into contact, forming layers of variable density; the egg placed in the fresh water will sink, but after oscillating up and down for some time will come to rest in a position in which the mass of fluid displaced is equal to that of the egg.

(ii) *The Cartesian Diver.*

A small glass bulb, Fig. 58, has an opening in its lower side; to the bulb is attached a small counterpoise, the weight of which is adjusted so that the whole just floats in water with some air in the bulb—the counterpoise often takes the form of a glass figure; hence the name of the apparatus. The water is contained in a tall jar and its top is closed with a piece of india-rubber. On pressing the india-rubber down the pressure of the air above the water is increased; this pressure is transmitted to the air in the bulb, which contracts in volume. More water enters the bulb, the weight of the bulb with its contents becomes greater than the weight of water which it displaces. Hence the diver sinks. When the pressure at the top of the vessel is relieved, the air in the bulb expands and the diver rises unless the vessel is too deep. If the vessel exceed a certain depth the pressure at the bottom, due to the water, may be so great even when the air-pressure on the surface is relieved, that the air in the bulb cannot expand sufficiently to again allow the diver to rise. By placing the vessel under the receiver of an air-pump and exhausting, it may again be brought to the top.

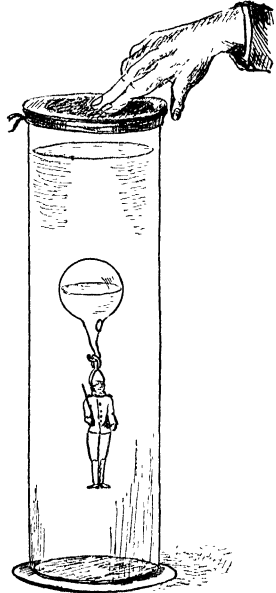

Fig. 58.

***55. Stability of equilibrium of a floating body.**

So far we have dealt only with the conditions of equilibrium; the problem whether the equilibrium is stable or not remains to be discussed.

**(i) When the body is totally immersed and just floats.*

The centre of buoyancy is the centre of gravity of the fluid displaced; if the body and the fluid be homogeneous it coincides with the centre of gravity of the body. In this case the two forces which act on the body pass through this point, and any position is one of equilibrium. The equilibrium therefore is neutral.

But if the centre of gravity and centre of buoyancy do not coincide, because, for example, either the body or the fluid is not homogeneous, various cases arise.

Suppose in the first case the body is not homogeneous. It may for example consist of a piece of wood with some lead fastened to it just sufficient in amount to allow it to float, or of a glass bulb and stem with some mercury in the bulb. Then we must distinguish between displacements in which the body moves without rotation—for these the equilibrium is neutral—and displacements in which the body is turned about some axis.

Fig. 59 (i), (ii) represent two cases which may occur; in each G is the centre of gravity, H the centre of buoyancy, in

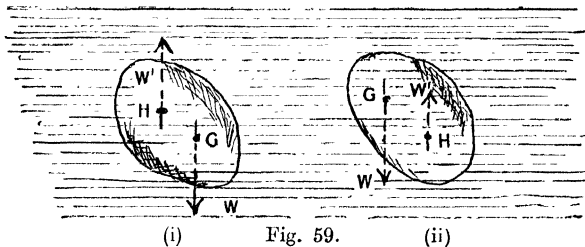

(i) G is below H , in (ii) it is above, and in each case the body has been displaced from its equilibrium position. The weight of the body acts downwards at G and the buoyancy acts upwards at H ; these forces are equal and thus constitute a couple. In (i) the couple tends to right the body, the equilibrium is stable; in (ii) it tends to increase the displacement, the equilibrium is unstable. For stable equilibrium the centre of gravity must be as low as possible.

Or take again the case of the egg floating in a solution of

salt and water of variable density; the lower layers are the denser; if the egg is depressed it displaces a volume of fluid greater in weight than itself, hence it rises again; while if it is raised the fluid displaced becomes less in weight than the egg and it sinks back to its original position, thus the equilibrium is stable. With the diver on the other hand the reverse is the case; when it begins to sink it continues to sink until the air pressure on the surface is reduced, or the bottom is reached.

**(ii) When the body is only partially immersed.*

The circumstances are now somewhat different. In the first place, such a body, if it can float at all, is in stable equilibrium for vertical displacements; if it be pushed down the buoyancy is increased, and it rises again; if it be raised out of the water the buoyancy is decreased, and the body sinks back.

But, though this is the case, the equilibrium for rotational motion may be either stable or unstable. A thin flat board *could* be made to float with its flat faces vertical and its edge downwards; in this position, however, it would be unstable and would tend to turn over until the flat sides became horizontal and the narrow edges vertical, when its equilibrium would be stable.

When the body is displaced, it is clear that in general the centre of buoyancy shifts its position in the body.

Let G , Fig. 60, represent the centre of gravity of the body, H its centre of buoyancy in the undisturbed equilibrium

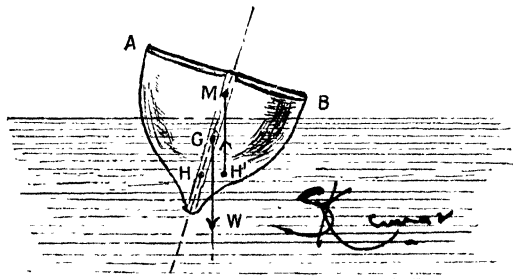

Fig. 60.

position, H' the new position of the centre of buoyancy when the body is displaced. Let us suppose that the form of the body is such that H , G and H' lie in a vertical plane, and also that the motion is such that the volume of water displaced remains unaltered, so that the buoyancy is unchanged¹. Draw $H'M$ vertical through H' , it will meet the line HG ; let M be the point of intersection, then the nature of the equilibrium will depend on the position of M . The buoyancy now acts vertically upwards through M , the weight vertically downwards through G , and these two forces constitute a couple. If M be above G the couple tends to restore the body to its original position, if M be below G the couple tends to displace the body further.

The position of H' and therefore of M depends on the shape of the body. If the displacement be very small the point M is known as the Metacentre, and the condition of equilibrium for small displacements is that the metacentre should be above the centre of gravity.

** DEFINITION. Imagine a floating body to be displaced through a small angle about a horizontal axis in such a way that the volume of fluid displaced may remain unchanged, and suppose further, that the displacement is such that the vertical line through the new position of the centre of buoyancy will meet the line joining the centre of gravity to the original position of the centre of buoyancy. The point of intersection of these two lines when the displacement is very small is the Metacentre.*

Thus we see that for small displacements the stability of a boat or other floating body depends on the position of the metacentre relative to the centre of gravity; for a boat of given shape and given weight it is important to keep the metacentre as low as possible. When the displacements to be dealt with may, as in the case of a ship, be considerable, other points besides the position of the metacentre must be attended to.

Examples. (1) *A piece of wood weighing 24 grammes floats in water with $\frac{2}{3}$ of its volume immersed. Find the density and the volume of the wood.*

(i) Since $\frac{2}{3}$ of the volume is immersed and the weight of the wood is equal to that of the water displaced, each cubic centimetre of the

¹ This condition is satisfied in the case, for example, of a ship which is made to heel either by the wind or through shifting some of the cargo.

wood weighs as much as $\frac{2}{3}$ of a cubic centimetre of water or $\frac{2}{3}$ of a gramme.

Thus the density of the wood is $\frac{2}{3}$ of a gramme per cubic centimetre.

The volume of the wood is its mass divided by its density or $24\frac{2}{3}$ c.cm. and this comes to 36 c.cm.

Thus the volume is 36 c.cm.

(ii) Otherwise thus. Let V be the volume in c.cm.

Then $\frac{2}{3}V$ is the volume of water displaced, and $\frac{2}{3}V$ grammes is the mass of water displaced; this is equal to the mass of the body.

$$\begin{aligned}\text{Hence} \quad \frac{2}{3}V &= 24, \\ V &= 36 \text{ c. cm.}\end{aligned}$$

Also Density = mass/volume = $24/36 = \frac{2}{3}$ grammes per c.cm.

(2) *A piece of wood of specific gravity .6 is floating in oil of specific gravity .85, what fraction of its volume is immersed?*

Since the volume of oil displaced is equal in weight to the wood, the two volumes are inversely as the specific gravities.

$$\text{Thus fraction of whole immersed} = \frac{\frac{2}{3}}{\frac{85}{80}} = .7.$$

(3) *A body whose volume is 30 c.cm. and specific gravity 1.5 is placed in a vessel and just covered with water. What thrust does it exert on the bottom?*

The weight of the body is 45 grammes, the weight of water displaced is 30 grammes, hence the thrust on the vessel due to the body is 15 grammes weight.

(4) *The mass of a balloon and its car is 3000 lbs., the mass of air displaced is 3400 lbs., with what acceleration does the balloon rise?*

The resultant upward force is

$$(3400 - 3000) \text{ or } 400 \text{ lbs. weight.}$$

This is equal to 400×32 poundals.

The mass moved is 3000 pounds.

Hence the acceleration is $400 \times 32/3000$ or about 4.26 feet per second.

(5) *A vessel containing water is placed on the pan of an upright spring balance and a body suspended from a second spring balance is immersed in the water. Examine how the readings of the two balances are altered.*

The reading of the second balance is reduced by the buoyancy of the water, acting upwards on the suspended body; the reading of the first balance is increased by the same amount, for the upward thrust of the water on the body is just equal to the additional downward thrust on the bottom of the vessel, due to the immersion of the body in the water.

Thus the sum of the two readings is unchanged, and this clearly must be so for the total mass supported by the two balances is not changed. See Experiments 11 and 12.

(6) *The specific gravity of sea water is 1.028 and of ice .918. What fraction of the volume of an iceberg floats out of water?*

The weight of the iceberg is equal to the weight of water displaced and the weight of any body is proportional to the product of its volume and its specific gravity. Hence,

Volume of sea water displaced $\times 1.028 =$ volume of iceberg $\times .918$.

$$\text{Hence} \quad \frac{\text{volume immersed}}{\text{whole volume}} = \frac{.918}{1.028}.$$

Therefore

$$\frac{\text{volume above water}}{\text{whole volume}} = \frac{1028 - 918}{1028} = \frac{110}{1028} = .107.$$

(7) *A body weighing 10 lbs. floats in a liquid with 1/3 of its volume above the surface. What weight must be placed on the body in order just to sink it?*

The specific gravity of the body is 2/3, hence the weight of water displaced by the body when just immersed is $\frac{2}{3}$ of 10 lbs. or 15 lbs. Hence the body will just float totally immersed if a weight of 5 lbs. be placed on it.

(8) *A rectangular block of boxwood 10 cm. in depth and of specific gravity .9, is floating in water with its upper surface horizontal. Oil of specific gravity .6 is poured on to the water, shew that, neglecting the buoyancy of the air, the wood will rise through 1.5 cm.*

Initially 9/10 of the wood is immersed, thus the height out of the water is 1 cm.; the weight of the wood is equal to the weight of water displaced.

When the oil is poured on, the weight of the wood is equal to the weight of water displaced together with the weight of oil displaced. Thus the weight of water displaced must be less than before, the wood therefore rises; let it rise h cm. and let A square cm. be the area of its upper surface.

The volume of the wood is $10A$ c.cm., that of the water displaced is $(9-h)A$ c.cm., and of oil $(1+h)A$ c.cm.

Equating then the weight of the wood to the weights of oil and water we have

$$.9 \times 10A = (9-h)A + .6(1+h)A.$$

$$\text{Hence} \quad 4h = 6 \quad \text{or} \quad h = 1.5 \text{ cm.}$$

Thus the wood rises 1.5 cm., remaining with 7.5 cm. in the water and 2.5 cm. in the oil.

(9) *A cylindrical rod weighted at one end floats in water, determine the conditions of stable equilibrium. If the rod can float with half its length immersed and at any angle to the horizon, shew that the weight which is added is equal to that of the rod.*

Let W be the weight of the rod, $2a$ its length, W_1 the weight added, and w the weight of a unit volume of water, l the length immersed, and a

the area of the cross section, and h the distance from the bottom of the centre of gravity of the rod and weight.

Then the weight of water displaced is $l\alpha\omega$, hence

$$W + W_1 = l\alpha\omega,$$

also taking moments about the bottom of the rod

$$h(W + W_1) = aW.$$

The centre of buoyancy which is at a distance $\frac{1}{2}l$ from the bottom must be above the centre of gravity.

Hence $\frac{1}{2}l$ is greater than h .

Thus l is greater than $2h$, or

$$\frac{W + W_1}{\alpha\omega} > \frac{2aW}{W + W_1},$$

or

$$\frac{(W + W_1)^2}{W} > 2a\alpha\omega.$$

Now $2a\alpha\omega$ is the weight of a volume of water equal to the volume of the rod, let this be W' , then the condition for stability is that

$$(W + W_1)^2 \text{ is greater than } W \cdot W'.$$

If the rod floats half immersed then $l = a$, while if any position is one of equilibrium, the centre of gravity coincides with the centre of buoyancy, hence

$$h = \frac{1}{2}l = \frac{1}{2}a.$$

Hence

$$W + W_1 = 2W \text{ or } W = W_1.$$

EXAMPLES.

FLOATING BODIES.

[For a Table of Specific Gravities see p. 15.]

1. A piece of oak 35 c. inches in volume floats in water, what volume of water does it displace?
2. What is the weight in water of 1 kilogramme of iron?
3. Ten kilogrammes of cork are totally immersed in water. What is the resultant thrust of the water, and what will be the acceleration with which the cork will rise if let go?
4. Find the resultant upward thrust on the following bodies when totally immersed:
 - (i) 100 c.c. of iron in water.
 - (ii) 250 grammes of copper in salt water.
 - (iii) 500 c.c. lead in sulphuric acid.
5. A lump of iron floats in mercury. What fraction of its volume is immersed?

6. A lump of iron is supported in water by cork so that $\frac{1}{3}$ of its volume is out of the water. Compare the volumes of the cork and iron.

7. What is the apparent weight of 25 grammes of iron when weighed in alcohol?

8. Find the weight of water displaced by 56 grammes of copper.

9. An iceberg floats with 2000 c. feet above the surface of salt water; find its volume.

10. A piece of cork floats in water with 50 c. inches above the water; find its volume.

11. A body weighing 30 grammes floats in water with $\frac{2}{3}$ of the volume submerged; find its volume.

12. A cylinder floats, with its axis vertical, totally immersed in water covered with a layer of oil. If $\frac{2}{3}$ of the cylinder be in the water, find its specific gravity.

13. Find the weight of a glass ball 2 inches in diameter (1) in air, (2) in water, (3) in alcohol. [Sp. gr. glass 3·6.]

14. A vessel of water is placed on one pan of a balance and counterpoised. If 35 grammes of lead, supported by a string are immersed in the water, what additional weights are required to restore the balance?

15. Two bodies whose specific gravities are 2·5 and 7·5 balance when each is weighed under water; find the ratio of their weights.

16. A man weighing 10 stone floats with 5 cubic inches out of the water; find his mean specific gravity and his volume.

17. A piece of oak $\frac{1}{3}$ immersed in water is supported by a string. What portion of the weight is carried by the string?

18. A lump of iron floats totally immersed partly in mercury and partly in water. What volume is there in each liquid?

19. Find the specific gravities of bodies which float with the following volumes above and below the surface of water respectively:

(1) Wood	21 : 24,	Ice	21 : 237,
Cork	3 : 1,	Oak	1 : 3.

20. A ship weighing 1000 tons passes from fresh to salt water, if the area of a section at the water line be 15000 square feet and the sides where they cut the water be vertical, how much will she rise?

21. A piece of iron weighing 275 grammes floats in mercury with $\frac{1}{3}$ of its volume immersed. Determine the volume and density of the iron.

22. How much water will overflow from the edges of a cup just full of water when a cork 2 cubic inches in volume is gently placed in it so as to float?

23. A cylindrical cork 4 inches long is to be loaded with iron of the same section so as just to float. How long must the iron load be?

24. A cone of a certain material floats point downwards with $\frac{3}{4}$ of its axis immersed; find its specific gravity.

25. A vessel contains water and mercury. A cube of iron, 5 cm. along each edge, is in equilibrium in the liquids, with its faces vertical and horizontal. Determine how much of it is in each liquid, the densities of iron and mercury being 7.7 and 13.6 respectively.

26. A piece of wood is floating on water, and oil is then poured on to the water. How is the volume of wood in the water affected?

27. A cubic metre of wood floats in water with $\frac{3}{4}$ ths of its volume immersed. Calculate the depth to which it would sink in a liquid of specific gravity .8.

28. A block of wood 10 lbs. in weight floats in water with two-thirds of its volume immersed. What force will be required just to sink it? Also what weight of a metal (specific gravity 5) must be placed on it so that both metal and wood may just be immersed?

29. A closed cubical vessel with walls one inch in thickness is to be made of metal whose specific gravity is $\frac{7}{4}$. Shew that in order that the vessel may float in water its internal dimensions must be at least 64 cubic inches.

30. A block of hard wood, 5 feet long, 6 inches wide and 4 inches thick weighs 52 lbs. Determine whether it will float (1) in ordinary water, (2) in sea water, the specific gravity of which is 1.026. If in either case it does float, how much of it will project above the surface?

31. A body whose specific gravity is 3 and whose weight is 6 lbs. is supported by a string with half its volume immersed in water. What is the tension of the string, the density of water being unity?

32. A small hole drilled at one end of a thin uniform rod is filled with some much denser material. It is observed that the rod can float in water half immersed and inclined at any angle to the vertical. Shew that the specific gravity of the rod is $\frac{1}{2}$.

33. A beaker of water is placed on the pan of a balance and counterpoised, a piece of glass suspended from a separate support is immersed in the water and it is found that 20 grammes have to be added to the counterpoise to restore equilibrium. Explain this and calculate the volume of the glass.

34. Account for the ascent of a balloon.

How would the lifting power of the balloon be altered if the atmospheric pressure be diminished?

35. Why does a ship rise when it goes out of a fresh-water river into the open ocean?

36. The specific gravity of ice is 0.92, that of sea water is 1.025. What depth of water will be required to float a cubical iceberg whose side is 100 feet?

37. A piece of iron (specific gravity 7.2) is covered with wax (specific gravity 0.96) and the whole just floats in water; its mass is 36 grammes; find the mass of the iron and the wax respectively.

38. A cubic foot of ice at the freezing point, one of whose edges is one foot long, floats in ice-cold water, but so that it is capable only of rotation about one edge which is hinged in the surface of the water: a weight of 42 ounces placed on the top of the cube of ice 10 inches from its hinged end just immerses the ice in the water. Find the specific gravity of the ice.

39. A large stone is held suspended under water by a rope. Explain why the load on the rope is less under these conditions than if the stone were suspended in air. If an addition of 10 lbs. to the load on the rope will break the rope, how much of the stone may be raised out of the water before the rope breaks?

CHAPTER VI.

MEASUREMENT OF SPECIFIC GRAVITIES.

56. General Considerations.

In many methods of determining specific gravities the fact that the resultant upward thrust on a body immersed in a liquid is equal to the weight of liquid displaced is made use of, for by this means we obtain the weight of a volume of liquid equal in volume to the body, and the specific gravity has been defined, Section 6, as the ratio of the weight of the body to the weight of an equal volume of some standard substance, usually water.

The procedure generally adopted is to weigh the body in air and then in water; the difference between the two gives the weight of water displaced, that is, the weight of an equal volume of water, and the ratio of the weight in air to this difference, is the specific gravity.

The **Hydrostatic Balance** and various forms of **Hydrometers** give examples of this method.

57. Hydrostatic Balance.

This is an ordinary balance arranged so that a body suspended from one end of the beam may be easily weighed in water.

In some forms a hook is attached below one of the scale-pans; this scale-pan is often attached to the beam by shorter chains than the other and the body to be weighed can be suspended from the hook.

In other forms, as shewn in Fig. 53 (*a*) (p. 98), a wooden stand or bridge rests on the floor of the balance case over one of the scale-pans which can swing freely below it, the supports of the scale-pan passing on either side of the bridge; the body to be weighed is suspended from a hook attached to the knife edge which carries the scale-pan. The vessel of liquid is placed on the bridge and the body can be immersed in it.

A spring balance often forms a convenient instrument for use as a hydrostatic balance. Jolly's balance is a special form of spring balance so used.

In many of the experiments to be described the solid has to be weighed in water. This introduces several sources of error.

If the solid is very light the weight of the wire or thread by which it is supported may need to be considered, moreover a capillary force is exerted on the wire where it cuts the liquid; it is therefore important that the supporting wire should be as fine as is consistent with strength. A horsehair or a piece of fine wire may be used, a piece of thread will serve but it absorbs moisture and so varies in weight as it gets wet.

Water again contains dissolved air, this collects in bubbles on the sides of the containing vessel or of any body immersed in the water and the apparent weight of the body is reduced by the buoyancy of these bubbles. The bubbles must be carefully brushed off the solid before weighing; for very accurate work it is desirable to boil the water and allow it to cool previous to use, or it may, if convenient, be placed for a time under the exhausted receiver of an air-pump. These precautions are clearly specially necessary in the case of a small body.

We proceed now to consider some experiments with the Hydrostatic balance.

EXPERIMENT 16. *To find, by the Hydrostatic balance, the specific gravity of a solid body which sinks in water, and to determine its volume.*

Suspend the body by a piece of fine wire from the pan of the balance and weigh¹ it. Let the weight be W grammes.

¹ In all these experiments several observations of the weight must be taken. For exact work the "method of oscillations," Glazebrook and Shaw, *Practical Physics*, § 12, p. 107, should be employed. For precautions to be observed in determining specific gravities, see Glazebrook and Shaw, *Practical Physics*, §§ 15-19.

Immerse the body in water and weigh it again. Let the weight be W' grammes; then $W - W'$ measures the upward thrust of the water on the body, and this, we know, is equal to the weight of water displaced. This water is clearly equal in volume to the body. Thus W grammes is the weight of the body and $W - W'$ grammes is the weight of an equal volume of water.

Now Specific gravity

$$= \frac{\text{weight of body}}{\text{weight of equal volume of water}} = \frac{W}{W - W'}$$

The volume of the body which is equal to that of the water displaced¹ is $W - W'$ cubic centimetres.

Thus, in the case of a piece of glass, the following observations were made:

Weight in air = 76.8 grammes.

Weight in water = 46.32 grammes.

Weight of water displaced = 30.48 grammes.

$$\text{Specific gravity} = \frac{76.8}{30.48} = 2.52.$$

Also volume of glass = 30.48 cubic centimetres.

EXPERIMENT 17. *To find, by the Hydrostatic balance, the specific gravity of a liquid.*

Weigh a body, say a piece of glass, in air; let the weight be W grammes. Then weigh it in water. Let the weight be W_1 grammes; weigh it in the liquid whose specific gravity is required, let the weight be W_2 grammes. Then $W - W_1$ = weight of a quantity of liquid equal in volume to the body, and $W - W_2$ = weight of a quantity of water equal in volume to the body.

$$\text{Hence the specific gravity of the liquid} = \frac{W - W_2}{W - W_1}$$

¹ In this statement the variation in the density of water with temperature is neglected.

Thus, using the same piece of glass as in the last experiment:

Weight in air = 76.8 grammes.

Weight in water = 46.32 grammes.

Weight in liquid = 43.88 grammes.

Weight of water displaced = 30.48 grammes.

Weight of liquid displaced = 32.92 grammes.

Specific gravity = $\frac{32.92}{30.48} = 1.08$.

EXPERIMENT 18. *To determine with the Hydrostatic balance the specific gravity of a solid body lighter than water.*

For this purpose a sinker is attached to the body of such a weight that the combination will sink in water.

(i) Weigh the solid in air, let the weight be W , weigh the sinker in air, let the weight be w , weigh the sinker in water, let the weight be w' , weigh the combination in water, let the weight be W' . Then

Weight of water displaced by sinker = $w - w'$.

Weight of water displaced by combination = $W + w - W'$.

Weight of water displaced by solid

$$= W + w - W' - (w - w') = W - W' + w'.$$

Hence

$$\begin{aligned} \text{Specific gravity} &= \frac{\text{weight of body}}{\text{weight of equal volume of water}} \\ &= \frac{W}{W - W' + w'}. \end{aligned}$$

Thus we have the following observations for a piece of wax.

Weight of solid = 26.65 grammes.

Weight of sinker (copper) = 11.38 grammes.

Weight of sinker in water = 10.10 grammes.

Weight of combination in water = 9.16 grammes.

Hence

Weight of combination in air = 38.03 grammes.

Weight of water displaced by combination = 28.87 grammes.

Weight of water displaced by sinker = 1.28 grammes.

Weight of water displaced by wax = 27.59 grammes.

$$\text{Specific gravity of wax} = \frac{26.65}{27.59} = .966.$$

(ii) *Otherwise thus.*

If it is convenient to support the sinker below the solid so that it can be immersed in water while the solid is not, the following method requires fewer weighings than that given above.

Weigh the solid in air, let the weight be W .

Attach the sinker below and weigh again with the sinker only in water, let the weight be W_1 .

Raise the vessel containing the water so that the solid is immersed as well as the sinker and weigh the combination in water, let the weight be W' .

Then, $W_1 =$ weight of solid + weight of sinker
 – weight of water displaced by sinker.

$W' =$ weight of solid + weight of sinker
 – weight of water displaced by sinker
 – weight of water displaced by solid.

$W_1 - W' =$ weight of water displaced by solid.

Hence
$$\text{Specific gravity} = \frac{W}{W_1 - W'}.$$

58. The Common Hydrometer

The principle of this instrument is most easily understood by considering a hollow cylindrical glass tube loaded at one end, so that it will float vertically in water and some other fluids, and having a graduated scale of millimetres either fixed inside or engraved on the glass; the scale is adjusted so that its zero may coincide with the bottom of the tube. Observations are made by noting the depth to which the hydrometer is immersed; this depth will measure the volume of fluid displaced.

Since the weight of the hydrometer remains unchanged, the

weight of fluid displaced is the same, whatever fluid it be immersed in.

Hence, if the tube sink to depths d , d' in two different fluids, the densities of these fluids are inversely¹ as d to d' . If the first fluid be water, the specific gravity of the second is d/d' .

Suppose, for example, that the instrument is so adjusted that it sinks to division 100 in water, and to division 92 in a solution of salt in water. Then the specific gravity of the solution is $100/92$ or 1.086.

Now an instrument such as this would be far from sensitive. A change of 1 mm. in the position in which it rests would mean an alteration of 1 per cent. in the specific gravity, and for accurate work this would be useless. Let us suppose however it were possible to have the tube over a metre long and let the reading in water be 1000, the reading in the salt solution 922, then the specific gravity is $1000/922$ or 1.085, an alteration of a millimetre in the reading will now mean an alteration of about one in a thousand, the instrument is more sensitive, but it is too long to be of use. In such an instrument however it is only the upper part of the stem which need be graduated. Thus if the graduations extended down to 800 the specific gravities of fluids from 1 to 1.250 could be measured, the rest of the stem will never rise out of the fluid. There is no need therefore for the lower part of the instrument to take the form of a straight stem at all. It may be made in any convenient form provided that its weight and volume are the same as those of the straight stem it replaces and also that it is so constructed as to float with the stem vertical.

In practice then the hydrometer usually takes the form shewn in Fig. 61. *A* is a hollow glass tube ending below in a bulb *C* which contains mercury so adjusted as to make the instrument float in a vertical position. The upright stem *B* is hollow and contains a paper scale. The scale is usually not divided into equal parts as in the simple form of apparatus described above, but in such a way that the readings of the scale may give directly the specific gravity of the fluid in which the instrument is immersed.

Let us suppose it is to be used for determining the specific gravities of fluids denser than water,



Fig. 61.

¹ See Section 51, Prop. 24 (Coroll.).

then the instrument rises as the fluid in which it is immersed is made more dense. The mercury in the bulb and the position of the scale then are adjusted so that, when floating in water, the top division of the scale which is marked 1·000 is level with the surface.

The scale is usually adjusted so that each division is equivalent to a change of ·001 in the specific gravity of the fluid, and each tenth division is marked; the divisions of the scale are not equal, but decrease in length as the bottom of the stem is approached.

It is not difficult to shew how the points on the scale may be obtained by calculation; in practice, however, it is simpler to determine a few points by immersing the instrument in turn in fluids of known specific gravities; the distances between these points are then subdivided by eye.

If the instrument is to be used to determine the specific gravity of fluids lighter than water, the mercury is adjusted so that it floats in water immersed just up to the bottom of the stem; when immersed in fluids of less density it sinks further; thus the graduation 1·000 is at the bottom, and the graduations run up the tube, becoming less towards the top.

Fig. 62 (i), (ii), shew an hydrometer floating in water and in spirit.

In order to get sufficient range without having very long stems, a series of hydrometers is generally employed. These are adjusted in such a way that one instrument may sink just up to the top of the stem in a given fluid, while the next will float in the same fluid with the whole of the stem exposed. Thus the scale runs on from one instrument to the next, and by a

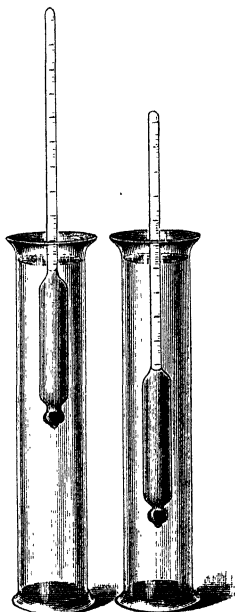

(i) Fig. 62. (ii)

proper choice of the hydrometer the specific gravity of any given fluid can be determined.

EXPERIMENT 19. *To use the common hydrometer to find the specific gravity of a liquid and to check its graduations.*

Immerse the hydrometer in the liquid and note the reading. This gives the specific gravity. To check the graduations determine in some other way the specific gravity of the liquid, e.g. by the hydrostatic balance, Section 57, or by the specific gravity bottle; the two results should agree.

59. Nicholson's Hydrometer.

This instrument, shewn in Fig. 63, consists of a hollow bulb to which a thin stem is attached, the stem carries a tray or cup, into which weights can be placed. Below the bulb hangs a second tray or basket. This is weighted with mercury, which is adjusted so that the instrument may float vertically in water.

On the stem there is a mark, when the instrument is used it is loaded so that this mark is just in the surface of the liquid in which it is floating. Thus whatever be the liquid the volume displaced is always the same.

EXPERIMENT 20. *To weigh a body and to determine its specific gravity by the use of Nicholson's Hydrometer.*

Place the hydrometer in a tall vessel of water and take care that it floats freely and that no air-bubbles are attached to it. Weights are to be placed in the upper cup to sink the hydrometer down to the mark. To avoid the inconvenience caused by these weights falling into the water, the top of the vessel is covered with two pieces of glass¹ which fit together and close it. The stem of the instrument rises through a hole which has been drilled in the glass.

Place weights on the upper cup till the instrument sinks to

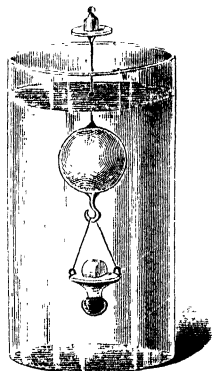

Fig. 63.

¹ The glass is not shewn in the figure.

the mark. It will be found that there is not a perfectly definite position of floatation for given weights, the hydrometer will, within limits, rest in any position. This is due chiefly to the capillary action between the water and the stem, the position will be more definite if the stem is free from grease; it may be cleaned before the instrument is used by being rubbed with cotton-wool soaked in alcohol.

Suppose the instrument is floating with the mark just below the surface. Take off some small weights till the mark just rises above the surface and note the weight left on; put on weights until the mark again sinks below and note the weights; do this several times and take the mean. Let it be W_1 .

Now place the solid in the upper cup; the instrument sinks. Take off weights until the mark is again in the surface. Determine as above the exact weight to be taken off. Let it be W , then W is clearly the weight of the solid.

Place the solid in the lower pan, taking care that no air-bubbles adhere, the weight supported is the same as before, but the solid is now acted on by the buoyancy of the liquid displaced, the instrument therefore rises. Place additional weights on the upper pan until it again sinks to the mark, determining their value as before. Let it be W' , then W' is clearly the weight of liquid displaced by the solid.

Hence the specific gravity is W/W' .

Instead of reckoning the weights taken off in the second operation and those added in the third, it may be more convenient to reckon the weights on in each case.

Let them be W_1 when the solid is not in either pan, w when the solid is in the upper cup, w' when it is in the lower cup.

Then the weight of the solid is $W_1 - w$ and the weight of water displaced $w' - w$.

Hence the specific gravity is $(W_1 - w)/(w' - w)$.

Thus in an experiment with sulphur the hydrometer was in adjustment with 8.35 grammes in the cup, the weights taken off when a piece of sulphur was placed in the upper pan were 5.81 grammes. This then was the weight of the sulphur; the weights added to these when the sulphur was transferred to

the lower pan were 2.92 grammes, giving the buoyancy of the sulphur.

Thus specific gravity of sulphur = $5.81/2.92 = 1.99$.

EXPERIMENT 21. *To find the specific gravity of a liquid with Nicholson's hydrometer.*

For this purpose we require to know the weight of the hydrometer; let it be W_0 .

Place the instrument in water and determine as before the weight required to sink it up to the mark. Let it be W_1 . Place the instrument in the liquid and let the weight required to sink it be W_2 . The weight of water displaced, since the hydrometer is floating, is $W_0 + W_1$. The weight of liquid displaced is $W_0 + W_2$. The volumes of these two weights are the same, each being equal to the volume of the hydrometer up to the mark.

Thus the specific gravity of the liquid is

$$(W_0 + W_2)/(W_0 + W_1).$$

In an experiment with a solution of salt in water containing 20 grammes of salt in 100 grammes of the solution, the weight of the hydrometer was 11.27 grammes, the weight required to sink it in water was 8.35 grammes. Thus the weight of water displaced was 19.62 grammes. The weight required to sink it in the salt solution was 9.88 grammes, thus the weight of salt solution displaced was 21.15 grammes.

Hence specific gravity of salt solution
= $21.15/19.62 = 1.078$.

60. Jolly's Balance.

This, as shewn in Fig. 64, consists of a long spiral spring which carries two light scale-pans one below the other. A vertical scale graduated on mirror glass is mounted behind the spring and a white

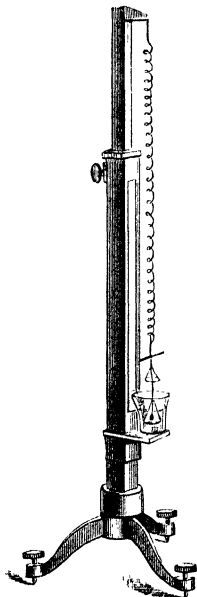

Fig. 64.

bead is attached to the end of the spring. The division of the scale opposite to the top of the bead can be read accurately, by looking at it with one eye closed, from such a position that the bead exactly covers its own image in the mirror. When using the apparatus the lower pan is kept always immersed in a vessel of water. The method of making measurements and the theory of the instrument are much the same as with Nicholson's hydrometer. Weights are placed in the upper pan until the bead comes opposite to some convenient division of the scale. The body to be weighed is then placed in the upper pan and weights removed until the bead is in the same position as before; this gives the weight of the body. The body is then transferred to the lower pan, thus causing the bead to rise, weights are added until the bead again occupies its sighted position; these weights give the buoyancy, and by dividing the weight of the body by its buoyancy we get the specific gravity of the body¹.

61. Specific Gravity Balls.

In order to obtain a rapid determination of the specific gravity of a liquid of which only a small quantity is available, a set of specific gravity balls is useful. These are small glass bulbs loaded with mercury, and so adjusted that each will just float in a liquid of definite specific gravity. A number of these balls are placed in the liquid to be examined, some of the balls sink, others float; if one be found which will just float the specific gravity of the liquid is known. If it happens that no one ball just exactly floats, limits can be found by noting the specific gravity of that ball, among those that sink, which most nearly floats; and the specific gravity of the ball, among those that float, which most nearly sinks. The specific gravity of the liquid lies between these two.

62. The Specific Gravity Bottle.

An experiment involving the use of the specific gravity bottle has already been described (see Section 9).

Two forms of bottle are shewn in Fig. 65 (i) and (ii). In (i) the bottle has a narrow neck which is open; a fine mark is

¹ For practical details see Glazebrook and Shaw, *Practical Physics*, p. 187.

made on the neck and in use the bottle is always filled exactly up to this mark. In (ii) the bottle is closed with a ground

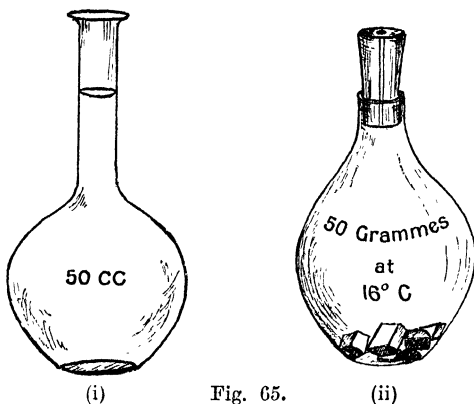

Fig. 65.

glass stopper, which is perforated with a small hole. The bottle is filled to the top of the neck with water or whatever other liquid is being used, and the stopper is then pushed home. The surplus liquid escapes by the hole in the stopper, leaving the bottle completely filled.

The specific gravity bottle is used to find the specific gravity of a liquid or of a solid which is either in the form of a powder or can be broken into small fragments and inserted in the bottle.

Bubbles of air easily collect among the fragments or on the sides of the bottle; care must therefore be taken to free the liquid used from air as far as possible.

The following experiments may be performed with the specific gravity bottle.

EXPERIMENT 22. *To find the specific gravity of a liquid with the specific gravity bottle.*

Weigh the bottle empty¹. Let its weight be W grammes;

¹ Before the bottle is weighed empty it should be dried. This is done by connecting a glass tube with a bellows and blowing air into the bottle. The tube is held over a Bunsen burner to heat the air before it enters the bottle.

then fill it with water and again weigh it. Let the weight be W_1 ; finally fill it with the liquid and weigh it. Let the weight be W_2 . In these last operations care must be taken that all traces of air-bubbles are removed from the sides of the bottle and from the stopper. $W_2 - W$ is the weight of liquid which fills the bottle, $W_1 - W$ is the weight of an equal volume of water.

Hence the specific gravity of the liquid = $\frac{W_2 - W}{W_1 - W}$.

In some cases it is convenient, instead of weighing the empty bottle, to counterpoise it with shot and lead foil. Then two weighings only are necessary.

The following observations were made.

Weight of empty bottle 6.85 grammes.

Weight of bottle filled with water 31.82 grammes.

Weight of bottle filled with liquid 30.43 grammes.

Hence

Weight of water filling bottle 24.97 grammes.

Weight of liquid filling bottle 23.58 grammes.

Specific gravity of liquid = $\frac{23.58}{24.97} = .944$.

EXPERIMENT 23. *To find the specific gravity of a solid in small fragments with the specific gravity bottle.*

Weigh the fragments of the solid; let the weight be W . Fill the bottle with water and place it with the solid on the pan of the balance. Let the combined weight be W_1 . Place the solid in the bottle and fill it up with water, taking care to get rid of all air-bubbles; let the weight be W_2 . This weight W_2 will be less than W_1 because water will have been displaced from the bottle by the solid and $W_1 - W_2$ will be the weight of the water displaced. The volume of this water is equal to that of the solid.

Hence specific gravity of solid = $\frac{W}{W_1 - W_2}$.

The following observations were made.

Weight of solid 5.67 grammes.

Weight of solid, bottle and water 37.49 grammes.

Weight of solid in bottle, bottle and water 34.62 grammes.

Hence

Weight of water displaced 2.87 grammes.

Specific gravity of solid = $\frac{5.67}{2.87} = 1.97$.

63. Solids soluble in water.

In the descriptions just given of the various methods of determining specific gravity it has been assumed that the solids used could be immersed in water. This of course is not always the case; salt, sugar, and many other substances when placed in water dissolve. If the substance whose specific gravity is required is soluble in water some other liquid must be employed in which it will not dissolve; thus sugar may be weighed in alcohol.

The result of the observations give us the ratio of the weight of a given volume of sugar to that of an equal volume of alcohol. Let us call this ${}_s\sigma_a$. Now the specific gravity of alcohol is the ratio of the weight of a given volume of alcohol to the weight of the same volume of water, let this be ${}_a\sigma_w$.

$$\begin{aligned} \text{Then we have} \quad & {}_s\sigma_a \times {}_a\sigma_w \\ &= \frac{\text{weight of 1 c.cm. sugar}}{\text{weight of 1 c.cm. alcohol}} \times \frac{\text{weight of 1 c.cm. alcohol}}{\text{weight of 1 c.cm. water}} \\ &= \frac{\text{weight of 1 c.cm. sugar}}{\text{weight of 1 c.cm. water}} \\ &= \text{specific gravity of sugar.} \end{aligned}$$

Hence the specific gravity of sugar is found by multiplying its specific gravity relative to alcohol by the specific gravity of alcohol.

Another method of procedure is to weigh the body, then to

coat it completely with a small quantity of wax of known specific gravity and then to find the specific gravity of the compound body. From this, since the weight of the body, the weight of wax and the specific gravity of the wax are known, the specific gravity of the body can be found (see Section 11).

Examples. (1) *A crystal of copper sulphate weighs 9 grammes in air and 5.68 grammes in turpentine of specific gravity .88. Find its specific gravity.*

The weight of turpentine displaced is 3.32 grammes.

Hence specific gravity relative to turpentine = $\frac{9}{3.32} = 2.71$.

Therefore specific gravity required = $2.71 \times .88 = 2.38$.

(2) *A piece of sugar weighing 32 grammes is coated with 3.6 grammes of wax of specific gravity .9. The weight of the whole in water is 11.6 grammes. Find the specific gravity of the sugar.*

The weight of the sugar and wax is 35.6 grammes.

The weight of water displaced is 24 grammes.

Therefore the volume of the whole is 24 c.cm.

The volume of the wax is $3.6 / .9$ or 4 c.cm.

Thus the volume of the sugar is 20 c.cm.

The mass of sugar is 32 grammes.

Hence the specific gravity of the sugar is $32/20$ or 1.6.

(3) *In Archimedes' experiment, Hiero's crown, together with lumps of gold and silver equal in weight to the crown, were each weighed separately in water. The crown lost $\frac{1}{14}$ of its weight, the gold $\frac{1}{7}$, and the silver $\frac{2}{11}$. In what proportion were gold and silver mixed in the crown?*

From the experiment it follows that the mean specific gravity of the crown was 14, that of the gold $\frac{14}{7}$ and of the silver $\frac{14}{2}$.

Suppose that in each cubic centimetre of the crown there is v c.cm. of gold, there will be $1-v$ c.cm. of silver. The weight of gold will be proportional to $77v/4$ and of silver to $21(1-v)/2$; the weight of a c.cm. of the whole is proportional to 14.

$$\text{Hence} \quad 14 = \frac{77v}{4} + \frac{21(1-v)}{2},$$

$$8 = 11v + 6(1-v),$$

$$2 = 5v.$$

Therefore $v = \frac{2}{5}$ of a cubic centimetre.

Hence the crown was composed of $\frac{2}{5}$ by volume of gold and $\frac{3}{5}$ of silver.

64. The U-Tube Method.

When two liquids which do not mix are poured into the two vertical limbs of a U-tube, the heights of the columns of liquids in the two tubes above the common surface are, as we have seen, different. The pressures at the common surface are the same in the two liquids; these pressures are measured respectively by the heights of the two columns, and since the densities of the two are different the heights are different.

A method of comparing the densities of two liquids which do not mix is based on this.

The apparatus employed is shewn in Fig. 66. The U-tube is mounted on a stand, and scales of millimetres are fixed beside each limb of the tube. The heights of the columns can be read on these scales.

EXPERIMENT 24. *To compare the densities of two liquids by observations on the heights of balancing columns.*

(i) Let $ABCD$, Fig. 66, be the U-tube. Let the one limb AB contain oil, the other water, and let B be the common surface of the two. Draw BC horizontal to meet the water in the other limb in C .

Let $AB = h$, $CD = h'$, let ω be the weight of a unit of volume of the oil, ω' of that of the water.

Then since B and C are points in the same fluid—the water—in the same horizontal line, the pressure at B is equal to that at C .

Let π be the atmospheric pressure.

$$\text{Pressure at } B = \pi + \omega h.$$

$$\text{Pressure at } C = \pi + \omega' h'.$$

$$\text{Hence} \quad \omega h = \omega' h',$$

$$\text{or} \quad \frac{\omega}{\omega'} = \frac{h'}{h}.$$

Thus the weights of unit volume of the two fluids, and therefore their densities, are inversely proportional to the heights of the respective columns.

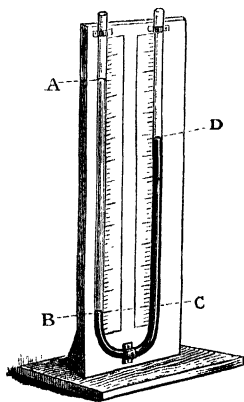

Fig. 66.

If the fluid in DC be water, as we have supposed, then the ratio ω/ω' measures the specific gravity of the fluid in AB .

Hence in this case

$$\text{Specific gravity of fluid in } AB = h'/h.$$

*(ii) If the liquids mix the apparatus requires modification; one form which is then useful is shewn in Fig. 67. Two U-tubes ABC , DEF are used, one limb of each being much longer than the other. The two shorter limbs are connected together by a piece of india-rubber tubing as shewn at G . A small quantity of liquid is poured into each tube, thus enclosing some air in the part CGD . Additional quantities of liquid are then poured into the tubes in turn; the air in the space CGD is gradually compressed, and finally the columns stand as in the figure.

Draw CB and DE horizontal.

Let $AB = h$, $FE = h'$, and let ω , ω' be the weights of unit of volume of the two liquids respectively.

Scales are placed alongside the two tubes, and the heights h and h' can be read off on these scales. Let π be the atmospheric pressure.

Then the pressure of the enclosed air at C and D is the same.

But pressure at C = pressure at B

$$= \pi + \omega h,$$

and pressure at D = pressure at E

$$= \pi + \omega' h'.$$

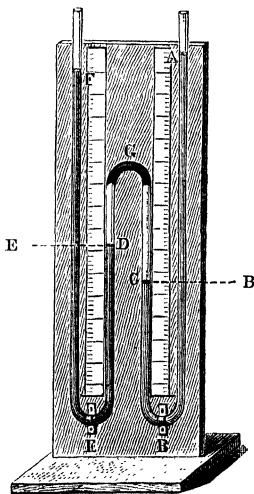

Fig. 67.

Hence $\omega h = \omega' h'$,

and as in (i) specific gravity of fluid in AB

$$= \omega/\omega' = h'/h.$$

Another form of the apparatus suitable for two fluids is shown in Fig. 68.

EXPERIMENT 25. *To compare the densities of two liquids which will mix by means of the inverted U-tube.*

An inverted U-tube $ABCD$, Fig. 68, dips into two beakers containing the liquids. At the top of the tube there is an opening to which a short length of india-rubber tubing is attached. This can be closed by a clip or by the insertion of a piece of glass rod. Air is sucked out of the tube through this upper opening, and the liquids rise in the two limbs of the tube. The rise of the liquid is caused by the atmospheric pressure acting on the surface of the liquids in the beakers (see Section 68). The heights of the columns of liquid in the two tubes will be found to be different. Scales are fixed to the apparatus and by their means the heights of the columns can be measured. Measure the two heights AB , CD , reckoning from the level of the liquid in the beakers in each case, let them be h and h' , and let ω and ω' be the weights of unit volume of the two liquids. Let π be the atmospheric pressure. Then the pressure of the enclosed air at B and C is the same, and the pressures at A and D of the liquids within the tubes are equal to the pressures at the same level of the liquids in the respective beakers. Each is therefore equal to π .

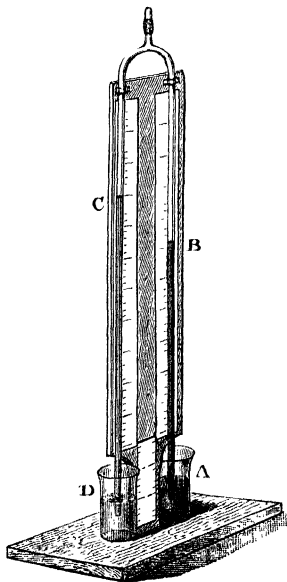

Fig. 68.

Hence from the column AB

$$\pi = \text{pressure at } B + \omega h,$$

and from column CD

$$\pi = \text{pressure at } C + \omega' h'.$$

Therefore $\omega h = \omega' h'$.

Thus, as before, the ratio of the weights of unit volume of the two liquids is inversely proportional to the ratio of the two heights. Also if the liquid in CD be water, we have

$$\text{Specific gravity of the liquid in } AB = \frac{\omega}{\omega'} = \frac{h'}{h}.$$

65. Columns in tubes of unequal Cross Section.

It should be noticed in connexion with the foregoing experiments that the area of the cross section of the tube is immaterial¹.

Each limb need not be of the same cross section throughout, and the sections of the two may be quite different; the results will be the same. Thus, to take the simple case of Fig. 66, the pressure at B , that is, the thrust per unit area over a horizontal section at B , is equal to the thrust per unit area over a horizontal section at C , but the whole thrust over the cross section at B need not be equal to the whole thrust over the cross section at C , for the areas of these two cross sections may be very different. It does not follow therefore that the weight of the fluid AB is equal to that of the column CD . The true statement is that the weight of a column of height AB and unit cross section is equal to the weight of a column of height CD and unit cross section.

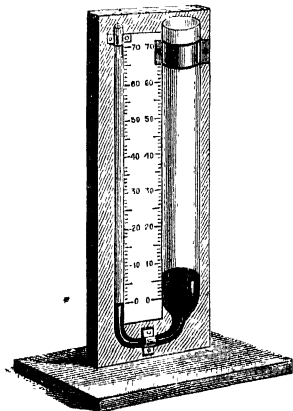

Fig. 69.

¹ If the tube be very narrow capillary action will produce an effect, but apart from this the statement is true.

In dealing with the problem when the two tubes have, as in Fig. 69, very different cross sections, let us consider an inner tube described within the wider tube and of the same cross section as the narrow tube. We may suppose that the column of fluid within this tube is balanced by the thrust due to the fluid in the narrow tube; the weights of these two columns measured from the common surface, are equal. The rest of the fluid in the wide tube is supported by the vertical component of the thrust on the sides of this tube.

Example. *The cross sections of the two limbs of a U-tube are 1 square inch and .1 square inch in area respectively. The lower part of both tubes contains mercury (specific gravity 13.6). What volume of water must be poured into the wider tube to raise the surface of the mercury in the narrow tube 1 inch?*

Since the cross sections of the two tubes are as 10 to 1, if the mercury rises 1 inch in the narrow tube it sinks .1 inch in the other. Thus the upper surface of the mercury is 1.1 inches above its surface of junction with the water in the wide tube.

Hence the height of the water column is 1.1×13.6 or 14.96 inches above this surface. Hence since the cross section of the water column is 1 square inch 14.96 cubic inches of water have been poured into the tube.

EXAMPLES.

SPECIFIC GRAVITY.

[For a Table of Specific Gravities see p. 15.]

1. Find the specific gravity in the case of each of the following substances in which the first number gives the weight in air, the second the weight in water in grammes weight:

256.3,	159.1;	311.9,	195.5;
511.6,	466.6;	123.0,	116.0.

2. In experiments on the specific gravity of some bodies which float in water a sinker weighing 87.2 grammes in water is used. Find the specific gravity in the case of each of the following bodies in which the first number gives the weight of the body in air, and the second the combined weight of the body and sinker in water:

20,	23.89;	50,	42.88;
63.5,	76.3;	105,	17.5.

3. A body whose weight in air is 56 grammes and in water 35 grammes has the following weights in a series of fluids :

33·5, 30·8, 29·2, 28·6.

Find the specific gravity of each of the fluids.

4. In a Nicholson's hydrometer 30 grammes are required to sink the instrument to the mark.

The weights necessary when a certain solid is (a) in the upper pan, (b) in the lower are respectively 2·54 grammes and 10·23 grammes; find the specific gravity and the volume of the body.

5. With a Nicholson's hydrometer for which the standard weight is 13·1 grammes the weights required with a given solid are 2·02 and 4·76 grammes; find its specific gravity.

6. The weight of a Nicholson's hydrometer is 53·6 grammes. In water 30 grammes are needed to sink it to the mark, and in a certain fluid 35·75 grammes are needed; find the specific gravity of the fluid.

7. If 35 grammes are required to sink a Nicholson's hydrometer in water and 61 grammes in a fluid of specific gravity 1·33; find the weight of the hydrometer.

8. A specific gravity bottle when filled with water is found to weigh 53·2 grammes. Some crystals weighing 2·6 grammes in air are then put in and the whole is found to weigh 54·75 grammes; find the specific gravity of the crystals.

9. An empty specific gravity bottle weighs 25·22 grammes; when filled with water the weight is 75·23 grammes, when filled with various liquids it is respectively 78·41, 71·23 and 76·85; find the specific gravities of the liquids.

10. The weight of a bottle full of water is 75·23 grammes. When crystals weighing 8·60 grammes in air are inserted the weight is 79·69; find the specific gravity of the crystals.

11. If 6·432 grammes of felspar are inserted into the same bottle the weight is 79·338 grammes; find the specific gravity of the felspar.

12. A piece of gold and a piece of silver are suspended from the two arms of a balance and are in equilibrium when the silver is immersed in alcohol, the gold in nitric acid. Compare the masses of the two.

13. The lowest graduation on the stem of an hydrometer is 1·000, the highest is 1·200; find the specific gravity of a fluid in which the instrument floats with the stem half immersed.

14. A solid whose specific gravity is 1·85 is weighed in a mixture of alcohol (specific gravity ·82) and water. It weighs 28·8 grammes in air and 14·1 grammes in the mixture; find the proportion of alcohol present.

15. The lower portion of a U-tube contains mercury; how many centimetres of alcohol (specific gravity $\cdot 82$) must be poured into one limb to raise the mercury 2.5 cm. in the other?

16. When a hydrometer floats in water 1 inch of the stem is exposed, when it floats in a liquid of specific gravity 1.2, 11 inches are exposed. How much will be exposed if it be placed in a liquid of specific gravity 1.1?

17. Shew that the volume of a body can be calculated from its weight in air and its weight in water, if the density of water be known.

18. A cubic foot of water weighs 1000 ounces, and 288 cubic inches of a certain substance weighs 128 lbs.; what is the specific gravity of the substance?

19. A piece of stone weighs 3 grammes in air, and 2 in water; find its specific gravity, and its volume.

20. A certain piece of lead weighs 30 grains in water. A piece of wood weighs 120 grains in air and when fastened to the lead the two together weigh 20 grains in water. Find the specific gravity of the wood.

21. The weight of a body is 25 grammes, when weighed in water at 4° C. it weighs 20 grammes. Shew that its volume is 5 c. cm. and its specific gravity 5. Explain the statement that its density is 5.

22. A lump of copper weighing 16 ounces is placed in a tumbler full of water, and causes 1.8 ounce of water to overflow: calculate the specific gravity of copper.

23. A lump of metal weighs 10 ounces, 8 ounces in water, and 7 ounces in a certain fluid; find the specific gravity of the fluid.

24. A piece of wood weighs 12 ounces, a piece of lead weighs $5\frac{1}{2}$ ounces, the lead weighs 5 ounces in water, the lead and wood together weigh 2 ounces in water. Find the specific gravity of the wood.

25. A beaker of liquid is placed in the scale-pan of a balance and counterpoised by 253 grammes. A cube of glass each of whose edges is 25.4 mm. in length is suspended by a very fine string from a separate support so that it is immersed in the liquid, and the counterpoise has to be increased in consequence to 265.9 grammes. Find the specific gravity of the liquid.

26. A lump of metal is known to consist of silver and gold, but it is not known how much is gold and how much is silver. The metal weighs 20 grammes in air and 18.7 in water, how much gold is there in the mixture?

27. Explain the principle of the common hydrometer.

The specific gravity corresponding to the lowest mark on the stem of a certain hydrometer is 1.8. What must be that corresponding to the highest mark if the reading midway between the two is 1.6?

28. The volume of a hydrometer is 10 c. cm. and its weight 7.5 grammes. Find how much of it will be unimmersed when set to float in a liquid of specific gravity 0.880.

29. Describe Nicholson's hydrometer and shew how to use it to determine the specific gravity of a solid lighter than water.

30. The lower portion of a U-tube with vertical limbs contains mercury (specific gravity 13.6). Some liquid is poured into the right-hand limb till it occupies 12 inches of the tube. The difference of level on the two sides is found to be 10 inches. What is the specific gravity of the liquid?

31. Explain how to compare the densities of two liquids which do not mix by means of a U-tube. Mercury is placed at the bottom of such a tube and water sufficient to occupy a length of 54 cm. of the tube is poured into one limb. By how much will the level of the mercury be altered and how much oil must be poured into the other limb to bring it back to its original position?

32. The lower portion of a U-tube contains mercury. How many inches of water must be poured into one limb of the tube to raise the mercury 1 inch in the other, assuming the specific gravity of mercury to be 13.6?

CHAPTER VII.

THE PRESSURE OF THE ATMOSPHERE.

66. Density of the Air.

The fact that air has weight was first proved by Otto Guericke, the inventor of the air-pump in 1650, and may be shewn as follows. Two large spheres of glass are suspended from the pans of a balance and counterpoised. The spheres should be nearly equal, both in weight and volume¹. One of them, Fig. 70, has a nozzle attached, by means of which it can be connected to an air-pump and exhausted. This is done and the sphere is replaced on the balance. It is found to be lighter than it was previously, its weight is reduced by the weight of the air it contained. The weight of a given volume of air depends (see *Heat*, Section 78 and also Chapter VII.) on its pressure and temperature. Under standard circumstances when the temperature is the freezing-point of water, and the pressure that due to a head of 76 centimetres of mercury, it has been shewn that a litre (1000 c.cm.) of dry air weighs

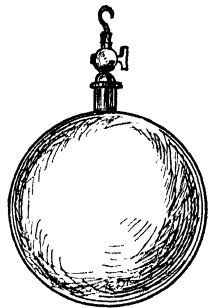

Fig. 70.

¹ By this means the correction for the buoyancy of the air is reduced. See Section 52.

1.293 grammes. Thus in these circumstances the density of air is .001293 grammes per cubic centimetre.

67. Density of different gases.

If the one globe in the experiment just described be filled with air, while the other is filled with different gases in turn, the pressure and temperature being kept constant, it will be found that equal volumes of different gases have different masses.

This can be shewn in the following way; suspend two beakers, approximately equal in size, from the arms of a balance; let the open end of one beaker be downwards, that of the other being upwards; if the weights of the two be not exactly equal, counterpoise the heavier with shot or sand. Allow coal-gas to pass from an india-rubber tube into the first beaker. The gas fills the beaker, displacing the air, and the balance arm rises, shewing that the coal-gas is lighter than air. Then remove the coal-gas and restore the balance. Now pass carbonic acid gas into the second beaker, it sinks; the carbonic acid is heavier than the air it displaces.

68. Pressure of the Air.

Various experiments can be performed to shew that air can exert a thrust on a surface with which it is in contact. Thus

(i) Close a small bladder and place it under the receiver of an air-pump; on exhausting the receiver the bladder swells and finally bursts; or again, close one end of a glass tube with a piece of thin sheet india-rubber, connect the open end to the air-pump and exhaust; the india-rubber is forced into the tube and bursts.

(ii) Depress a beaker or tumbler, mouth downwards, into water, it will be found that the surface of the water within the beaker is below that outside.

(iii) The effect of the pressure due to the atmosphere is shewn in von Guericke's ex-



Fig. 71.

periment with the Magdeburg hemispheres, Fig. 71. A receiver is formed by two hemispheres which fit so closely together as to be airtight. When the receiver is full of air they can be easily separated. On exhausting the receiver however very great force is needed to separate the two halves. In von Guericke's original experiment it is said that a team of 16 horses was needed to pull the two hemispheres apart.

(iv) Dip a tube into water or mercury and exhaust the air in the upper part of the tube. The liquid rises in the tube in consequence of the pressure of the air on its free surface. Galileo discovered that water could not be raised in this manner more than 18 Italian ells, about 33 feet. Thus the pressure of the air is equivalent to a head of water of about 33 feet. Torricelli suggested the use of a head of mercury rather than of water to measure the atmospheric pressure, and this idea was carried out by Viviani in 1643 and is exemplified in the barometer.

69. The Barometer.

A glass tube about a metre long and 1 to 1.5 cm. in diameter, is closed at one end and filled with clean dry mercury. Care must be taken to expel from the tube all traces of air. For this purpose close the open end of the tube with the thumb, leaving a small quantity of air above the mercury. Then, by inclining the tube gently, pass this bubble of air from end to end and thus include in it the small bubbles of air which adhere to the glass; in this way nearly all the air can be got rid of¹.

Now fill the tube completely, close the open end with the thumb in such a way as to leave no air between it and the mercury, invert the tube and place the lower end below the surface of the mercury in a small trough. If the thumb be now removed the mercury will descend in the tube, but after a few oscillations, remain stationary at a height of about 76 centimetres above the mercury in the trough. If sufficient

¹ For accurate instruments the remainder of the air is removed by heating the mercury in a suitably constructed furnace till it boils in the tube.

care has been taken the space in the tube above the mercury is a vacuum, except for the presence of a little mercury vapour. On inclining the tube gently the mercury will rise to the top and completely fill it. On again placing the tube vertical it will sink to its former level.

The pressure on the upper surface at *B*, Fig. 72, is that due to the mercury vapour, and this is practically inappreciable. The pressure at *A*, a point in the tube at the same level as the mercury in the trough, is that due to the head of mercury *AB*. The pressure at a point in the free surface of the mercury, i.e. at the same level as *A*, must be the same as at *A*; this pressure is due therefore to the head of mercury *AB*. There is therefore exerted on the surface of the mercury in the trough a downward pressure measured by the height of the column *AB*. This downward pressure is due to the atmosphere, it measures the weight of a column of air of unit cross section and of height equal to that of the atmosphere.

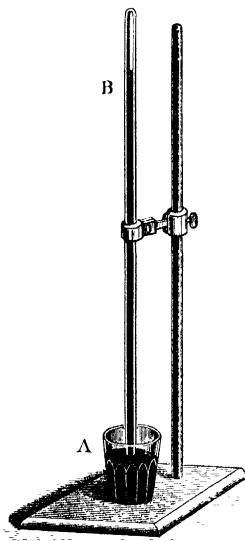

Fig. 72.

The following experiments illustrate these points.

EXPERIMENT 26. *To shew that the height of the mercury in a barometer depends on the pressure of the air.*

You are given two barometer tubes. In the one, Fig. 73 (i), the tube is moveable and can be inclined to the vertical at various angles. In the other, Fig. 73 (ii), the reservoir is under the receiver of an air-pump. Place the first with its tube vertical and note the height of the mercury in the tube above that in the reservoir. Then incline the tube at various angles to the vertical and measure the vertical height in each case. It will be

70. Pascal's Experiment.

Pascal took a long glass tube of the form shewn in Figure 74; the tube is open at *A* and *B*, but can be closed at *B* with a close-fitting cork; each of the lengths *AB*, *CD* is greater than the barometric height. The whole is filled with mercury and placed with *A* downwards in a vessel of mercury. On opening the end *A*, while *B* is closed, the mercury separates into two portions as in the figure, with a vacuous space between them at *B*. The height of the column in *AB* is that of the barometer, the mercury in *CD* is all collected near *C*, and the level of the mercury in *CD* and *CB* is the same.

The cork is then withdrawn from *B* and the atmosphere thus has access to the mercury near *B*. The column in *AB* is thus driven down the tube to the reservoir, the pressure on the column in *BC* drives it up the tube *CD*, and it now stands with its upper surface at the barometric height above that in *CB*.

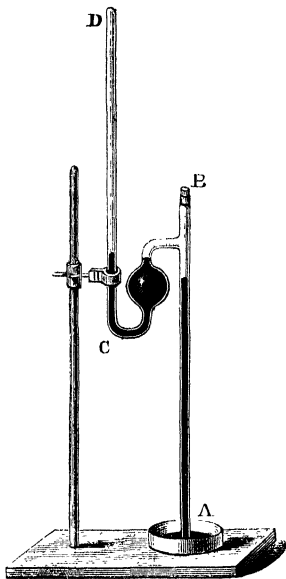

Fig. 74.

71. Fortin's Barometer.

Mercury barometers are made in various forms, according to the purposes for which they are required; the form most commonly employed in a laboratory is Fortin's, shewn in Fig. 75. In this instrument the barometer tube is enclosed in a brass tube which forms the scale for reading the height of the mercury. The cistern is attached to this scale and the instrument is suspended from a hook or other suitable support by a ring at the top. As the mercury in a barometer tube rises or falls the mercury in the cistern falls or rises.

By making the area of the tube small in comparison with that of the cistern the rise and fall in the latter can be made small; still for accurate work it is necessary either to allow for this in the graduations, or else to arrange that the zero mark of the scale may readily be brought to coincidence with the surface of the mercury in the cistern. In Fortin's barometer the bottom of the cistern is made of leather and it can be raised or lowered slightly by means of a screw shewn in the figure. The zero of the scale coincides with the point of a small ivory index which is visible above the mercury in the cistern. A reflected image of this index in the surface of the mercury can also be seen. The mercury surface is adjusted by means of the screw until the point of the index and its image appear just to touch, then the level of the mercury in the cistern coincides with the zero of the scale. The scale, as shewn in the figure, is usually only graduated from about 27 to 32 inches. A sliding vernier is attached, by means of which the scale can be read to one five-hundredth of an inch. The scale is in inches divided into twentieths, and twenty-five divisions of the vernier are equal to twenty-four of the scale. The vernier slides in a vertical slot in the upper portion of the brass tube, and through this slot the mercury is visible. At the back of the tube there is a corresponding slot in which a brass plate connected with the vernier slides. The lower edge of this plate is at the same level as the zero of the vernier; hence an observer whose eye is placed so as just to see the edge of the brass plate behind the vernier is looking in a horizontal direction. The top of the column of mercury is slightly convex and, in reading the instrument, the vernier is raised until there is a clear space above the mercury; it is then gradually lowered until the top of the mercury column, the lower edge of the plate of brass at the back, and the lower edge of the vernier all appear in the same line. By this means it is secured that the zero of the vernier is at the same height as the top of the column; for the observer, when the

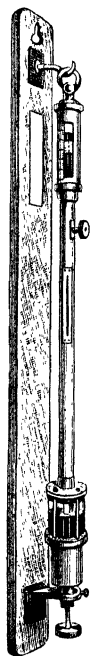

Fig. 75.

reading is taken, is necessarily looking in a horizontal direction.

*72. Corrections to the barometer reading.

The height thus read requires various corrections.

The atmospheric pressure is measured by the weight of a certain column of mercury. The weight of the column depends on its height, on the density of the mercury, and on the value of g , the acceleration due to gravity. Moreover the mercury column is depressed, though very slightly, by the pressure due to the mercury vapour above it, and by the capillary action at the sides of the tube.

i. Correction for Temperature.

The height of the column is measured by a brass scale. Now brass expands when its temperature rises, so that if the scale be correct at some standard temperature, such as the freezing-point of water, 0°C ., it will be too long at any other temperature. But it is known that a centimetre of brass expands¹ in length by $\cdot 000019$ cm. for each rise of temperature of 1° , and that the increase of length is proportional to the rise of temperature.

If we denote this coefficient by a , then, for t° , the increase in length of each centimetre is at centimetres, hence if h centimetres is the height of the column as read on the scale, the true height is H where $H = h(1 + at)$.

We have thus found the true height of the column of mercury, but we need the weight of the column. Now the density of mercury decreases as the temperature rises and the decrease, for each degree of temperature, is $\cdot 000181$ of the density at 0°C . Let us denote this fraction by γ , then if ρ_0 is the density at 0 , the density at t° is $\rho_0/(1 + \gamma t)$.

Thus at t° the weight of the column is less than that of a column of equal height at 0° in the ratio 1 to $1 + \gamma t$.

Thus the height of a column at 0° which would give the same pressure as that observed is $H/(1 + \gamma t)$.

¹ Glazebrook, *Heat*, pp. 55, 62, 92.

Hence, substituting for H in terms of h we find for the height of the barometer corrected to zero Centigrade the value H_0 where,

$$H_0 = \frac{h(1 + at)}{1 + \gamma t}.$$

Now a and γ are so small that quantities like $\gamma^2 t^2$ or $a\gamma t^2$ may be neglected.

Hence, dividing by $1 + \gamma t$, we get

$$\begin{aligned} H_0 &= h(1 + at - \gamma t) \\ &= h - h(\gamma - a)t. \end{aligned}$$

Again, $\gamma - a$ is very small, being for mercury and a brass scale equal to $\cdot 000181 - \cdot 000019$ or $\cdot 000162$, hence the last term is very small. At any one place the value of h does not vary very greatly; thus at sea-level it may range from 70 to 80 cm. We may therefore without serious error calculate the value of $h(\gamma - a)$ as though h had its mean value 76 cm. and it becomes $76 \times \cdot 000162$ or $\cdot 0123$ cm. We thus arrive at the following approximate rule.

To reduce the barometer reading to zero Centigrade subtract from the observed reading at t° $\cdot 0123 \times t$ centimetres.

Thus, if the observed reading is 74 centimetres and the temperature 15° , the true reading is $74 - \cdot 184$ or 73.816 centimetres.

This correction is not quite accurate, it ought to be $74 \times \cdot 000162 \times 15$ or $\cdot 179$ cm., but the difference of five-hundredths of a millimetre is, for most purposes, inappreciable.

ii. *Correction for Capillarity.*

The capillary action always depresses the mercury column, the correction required depends on the bore of the tube and also on the methods employed in cleaning it. If the mercury has been boiled in the tube, the correction for a tube of about 1 cm. in diameter is about $\cdot 02$ millimetres; this must be added to the observed height.

iii. *Correction for Vapour Pressure.*

Again, the vapour pressure of the mercury depresses the column; the correction therefore is to be added to the column,

but it is very small, being approximately equal to $\cdot 002 \times t$ mm. where t is the temperature.

iv. *Correction for Value of Gravity.*

The value of g depends on the latitude and on the height of the place of observation; it is usually referred to sea-level in 45° of latitude. It is known from the theory of the figure of the Earth that, if g be the value at a height of l metres in latitude ϕ , g_0 the value at sea-level in latitude 45° , then

$$g = g_0 (1 - \cdot 0026 \cos 2\phi - 0000002l).$$

In order to correct then to sea-level and 45° of latitude, the observed height must be multiplied by

$$1 - \cdot 0026 \cos 2\phi - \cdot 0000002l.$$

v. *Correction for Capacity of the Cistern.*

If the level of the mercury in the cistern be not adjustable, the correction for the rise and fall in the cistern may be considerable. Let us suppose the mercury in the tube rises a distance x from its standard position; the mercury in the cistern falls a distance X say. The true increase in the height of the column therefore is $x + X$. Now let a be the area of the mercury in the tube, A that of the mercury in the cistern. Since the volume ax of mercury which has entered the tube has come from the cistern it must be equal to the volume AX which has left the cistern.

Thus $AX = ax$

and $X = \frac{a}{A} \cdot x.$

Hence the true rise is

$$x + \frac{a}{A} \cdot x \text{ or } x \left(1 + \frac{a}{A} \right).$$

Thus, if a rise of x centimetres be observed, it has to be corrected, to obtain the true rise, by multiplying it by $1 + a/A$.

In some instruments this correction is avoided by making the divisions too small in the ratio 1 to $1 + a/A$.

73. Forms of Barometer.

There are various other forms of mercurial barometer. In the wheel barometer, which is very commonly used, the tube is U-shaped; the two limbs being of very unequal length. The longer limb is closed and above the mercury there is a Torricellian vacuum, the shorter limb is open and the atmospheric pressure acts on the mercury it contains. A small piece of iron or glass floats on the surface of this mercury and is partly supported by a light thread which passes over a pulley and carries a counterpoise. To the axis of the pulley is fixed a pointer which moves over a dial. Changes in the level of the mercury in the tube are thus indicated by the motion of the pointer.

The siphon barometer is an instrument similar to the above but without the weight and pointer. The bore of the two tubes is usually the same, so that the mercury falls as much in one limb as it rises in the other. Scales are however generally provided for each limb. The divisions in the upper scale to be reckoned upwards, those in the lower scale downwards.

*74. Standard Barometer.

It is never easy to read accurately the position of a mercury surface which cannot be reached, and therefore the exact determination of the height of the barometer is not very easy. In some standard instruments a small index of glass or metal is fixed in the glass tube above the surface of the mercury; the point of the index is directed downwards. The cistern below is adjustable, and the level of the mercury column in the tube can be raised or lowered until it comes in contact with the tip of the index. When this is the case the index and its image, formed by reflexion in the mercury, just coincide.

The exact position, relative to the scale, of this index can be determined once for all, and hence the level of the top of the column can be found. A similar index is fitted to the lower part of the scale and can be made to slide up and down by a rack and pinion or in some other way. To this index the vernier is attached.

The height is measured by adjusting the cistern until the upper index is in contact with the mercury in the tube, the lower index is then brought into contact with the surface of the mercury in the cistern and the scale and vernier are read. The distance between the indices is thus found with accuracy and is the barometric height.

75. The Aneroid Barometer.

The principle of this instrument is the same as that of Bourdon's gauge. (Section 39.)

A small chamber is closed with a diaphragm of thin corrugated metal and partially exhausted. Variations in the external pressure cause this diaphragm to yield to an amount proportional to the change of pressure; the motion of the diaphragm is magnified by means of a lever and transmitted to an index, by this means the variations of pressure are indicated.

In other instruments the chamber takes much the same shape as in the gauge, it is, however, closed and exhausted and the variations in its form are due to changes in the external pressure.

An aneroid barometer can be arranged to record its indications on a piece of moving paper by means of a pencil fitted to a long lever; it then becomes a barograph.

An aneroid barometer should be graduated by direct comparison with a mercury instrument; while for many purposes, owing to its great portability, it is of more use than the standard form, still its indications, specially if it be subject to rapid changes of pressure, must not be implicitly relied on. The metal diaphragm is rarely perfectly elastic; it does not therefore always take up immediately the same position for a given pressure, and changes in its form progress for some time after the change of pressure to which they are due has taken place. Changes in temperature also may produce some alteration in the reading though good instruments are usually compensated for these.

76. Measures of Atmospheric Pressure.

The standard atmospheric pressure is measured by the weight of a column of mercury at 0°C. , one square centimetre in section and 76 centimetres high.

Since the weight of a cubic centimetre of mercury is 13.59

grammes weight, the atmospheric pressure per square centimetre is $13\cdot59 \times 76$ or $1032\cdot8$ grammes weight. Again, the weight of 1 gramme in London contains¹ 981 dynes or absolute c.g.s. units of force. Thus the pressure of the standard atmosphere is $1032\cdot8 \times 981$ or 1013177 dynes per square centimetre.

This is approximately $1\cdot013 \times 10^6$, or rather greater than one million dynes per square centimetre.

Now one square inch contains $6\cdot451$ square centimetres. Thus the thrust on a square inch is $1032\cdot8 \times 6\cdot451$ grammes weight. Also 1 lb. contains $453\cdot6$ grammes. Hence the pressure of the standard atmosphere in pounds weight per square inch is

$$\frac{1032\cdot8 \times 6\cdot451}{453\cdot6} \text{ or } 14\cdot69.$$

Thus there is a thrust of nearly 15 pounds weight on each square inch of the Earth's surface.

In England the standard height of the barometer is usually taken to be 30 inches.

Since 1 inch is equal to $2\cdot54$ centimetres, 30 inches is equal to $76\cdot2$ centimetres. Thus the standard height of the barometer on the metric system differs slightly from that adopted in England.

77. Water Barometer.

A barometer might be made with other liquids than mercury; water, for example, might be used, but in this case the tube would be very long; for, since mercury is $13\cdot59$ times as dense as water, the height of a water column which would balance the column of the mercury barometer would be $13\cdot59$ times its height or $13\cdot59 \times 76$ centimetres. This reduces to $1032\cdot8$ centimetres or $10\cdot328$ metres.

Since the weight of 1 cubic centimetre of water is 1 gramme weight, the height of the water barometer in centimetres is equal to the pressure per square centimetre in grammes weight.

¹ *Dynamics*, Section 85.

Again, 1 foot contains 30·48 centimetres, so that the height of the water barometer in feet is $1032\cdot8/30\cdot48$.

This comes to about 33·88 feet.

Another objection to the water barometer is that the vapour pressure¹ of water is considerable and increases rapidly with the temperature. In consequence, therefore, the column will be depressed by a considerable amount and this amount will vary with the temperature; thus the correction for the pressure in the closed space above the column becomes considerable and is troublesome to apply.

The glycerine barometer is free from this disadvantage and is sometimes used.

78. Height of the Homogeneous Atmosphere.

Since the barometer column is balanced by the weight of a column of air extending from the earth's surface upwards as far as there is air, it is possible, if the density of the air be known, to calculate the height of this column. But the density of the air decreases, as we ascend, according to a complex law, and a limit to the height of the atmosphere cannot thus be found. We may, however, calculate how high the air would be if it were homogeneous throughout and of sufficient height to produce the pressure actually observed. Now this pressure is equal to the weight of 1032·8 grammes per square centimetre, and the weight of 1 cubic centimetre of dry air at freezing point and standard pressure is ·001293 grammes weight. The air column therefore must be $1032\cdot8/\cdot001293$ or about $7\cdot988 \times 10^5$ centimetres.

But 10^5 centimetres is 1 kilometre.

Hence the height of the homogeneous atmosphere is 7·98 kilometres.

Again, 1 mile is 1·609 kilometres.

Thus the height of the homogeneous atmosphere is $7\cdot98/1\cdot609$ or about 4·97 miles.

We may say then that the pressure on the Earth's surface is about the same as it would be if the earth were surrounded

¹ See Glazebrook, *Heat*, Section 116.

by an ocean of air, 5 miles in depth and of the same density throughout as the air is at the Earth's surface.

*79. Measurement of heights by the Barometer.

Observations with the air-pump have shewn (Section 69) that the reading of the barometer depends on the pressure of the air, and we have seen that air like other fluids has weight. Now the pressure at any point of a body immersed in a heavy fluid depends on the depth to which that body is immersed; if the depth be reduced by raising the body, the pressure is reduced also.

Thus consider a flexible bag tied on to the end of a glass tube as shewn in Fig. 76. Fill the bag with mercury or some other fluid and immerse it in a vessel of water, keeping the upper end of the tube above the surface of the water. The bag is squeezed by the water pressure and the mercury rises in the glass tube, becoming higher as the bag is depressed.

Or again, instead of enclosing the mercury in the flexible skin, place it in a beaker and insert in the mercury one end of a long glass tube open at both ends, then immerse the beaker and tube in a vessel of water, keeping the lower end of the tube under the mercury and the upper end above the surface of the water. The pressure of the water on the surface of the mercury drives it up the tube. A column of mercury is supported by the water pressure in just the same way as the barometer column is supported by the air. Clearly also, if the depth of the beaker be altered, there will be a relation between the alteration of depth and the change of height of the column. Alterations in depth could be measured by observing the change in height of the column.

When the liquid is water the alteration of depth is given by multiplying the change in the height of the mercury column by the specific gravity of mercury.

The same principles apply to the atmosphere. If the rise of the mercury in a barometer tube really be due to the weight

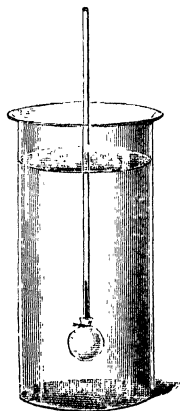

Fig. 76.

of the air above the mercury in the cistern, then when the barometer is carried up a mountain, the column will fall and there will be a relation between the amount of the fall and the height of the mountain.

This was pointed out by Pascal, and his prediction that the column would fall was verified by Clermont, who in 1648 made use of the method for the first time, to measure the height of the Puy-de-Dôme.

In employing the method to determine the difference in level of two stations the barometer is read at the two stations. From the difference in readings the weight of the column of air between the two can be calculated; hence, if the density of the air be known, the height of the column can be found, and this height is the difference of level required. It remains therefore to calculate the relation between the weight of the column and its height. Now the density of the air depends on its temperature and pressure. When the pressure is p centimetres of mercury and the temperature t° Centigrade, the density, ρ , is given in terms of ρ_0 , the density at 0° C. and 76 cm., by the formula¹

$$\rho = \rho_0 \times \frac{273}{273 + t} \times \frac{p}{76},$$

but p and t both vary as the mountain is ascended and the calculation becomes complex. We may, however, assume, if the difference in level is not very great, that the column of air considered is of the same weight as it would be if the air were throughout at a uniform pressure and temperature equal to the mean of those observed at the two stations.

Observe then the pressure and temperature at each of the two stations and calculate from the above formula the value of the density corresponding to their mean, assuming the density at 0° C. and 760 mm. pressure to be .001293 grammes per c.cm.

Let H be the required difference in level, h_1 and h_2 the two barometer readings corrected in the manner described in Section 72, then the column of air balances a mercury column of height $h_2 - h_1$. Thus if ρ be the density of the air

$$\rho H = 13.59 \times (h_2 - h_1).$$

¹ See Sections 80, 83; also Glazebrook, *Heat*, Section 102.

$$\text{Hence} \quad H = (h_2 - h_1) \times \frac{13.59}{\rho}.$$

Example. *The barometer at the lower station reads 751.9 mm. and at the upper 633.7 mm., while the temperatures of the air at the two are 13° C. and 7° C. respectively. Find the difference in level.*

The difference in pressure is 118.2 mm., the mean pressure is 692.8 mm. and the mean temperature 10° C.

The mass of a column of air 1 square centimetre in section between the stations is 13.59×11.82 grammes. The density of air at 692.8 mm. pressure and 10° C. is

$$\frac{.001293 \times 692.8 \times 273}{760 \times 283}.$$

Hence the difference in level is

$$\frac{13.59 \times 11.82 \times 760 \times 283}{.001293 \times 692.8 \times 273} \text{ cm.,}$$

or about 1413 metres.

In obtaining the result no allowance has been made for the aqueous vapour in the air. In consequence of its presence the density will be rather greater than the value used above. The difference in level, therefore, should be less.

We may obtain a more accurate formula thus :

Suppose that at the lower station the height of the barometer is h_0 and that, in going to a height of z metres, it falls to a height kh_0 , k being a proper fraction.

Suppose further that the temperature is uniform and that z is so small that we may treat the density of the air as constant throughout each stratum of thickness z , though it changes as we pass from one stratum to the next.

On rising through a second distance z the barometer will fall by the same fractional amount as previously, for the fall is proportional to the average density of the stratum through which the barometer is being carried; and this average density in the second stratum bears the same relation to the pressure at its under side or kh_0 as the average density in the first stratum does to the pressure h_0 . Hence, at the top of the second stratum, the height of the barometer is k^2h_0 .

On rising through a third stratum the pressure falls to k^3h_0 and so on in succession.

Thus, for a series of heights in arithmetical progression, the barometer readings form a series in geometrical progression with the common ratio k .

Now, let H be the total height through which the barometer is raised, and let the distance H be divided into n -layers, each of thickness z , throughout each of which we may treat the density as constant.

Then $H = nz$, while, if h be the barometer reading at the top, $h = k^n h_0$.

Therefore
$$k^n = \frac{h}{h_0}.$$

Hence, taking logarithms,

$$n \log k = \log \left(\frac{h}{h_0} \right) = \log h - \log h_0.$$

But
$$n = \frac{H}{z}.$$

Hence
$$H = \frac{z}{\log k} (\log h - \log h_0).$$

Again, if ρ_0 be the average density of the air in the first layer of thickness z at the lower station and σ the density of mercury,

then
$$g\sigma(h_0 - h_1) = g\rho_0 z,$$

for the difference in the heights of the barometer is due to the weight of a column of air of height z .

Also
$$h_1 = kh_0.$$

Hence
$$h_0(1 - k) = \frac{\rho_0 z}{\sigma}.$$

Moreover, if z is small, k is very nearly equal to unity, and we may write $k = 1 - x$ where x is very small.

Hence
$$xh_0 = \frac{\rho_0 z}{\sigma}.$$

Also
$$\begin{aligned} \log k &= \log(1 - x) \\ &= \log_e(1 - x) \log_{10} e = -x \log_{10} e, \end{aligned}$$

since x is very small.

Thus
$$H = \frac{z}{x \log_{10} e} \{ \log h_0 - \log h \}.$$

But
$$\frac{z}{x} = \frac{\sigma h_0}{\rho_0}.$$

Therefore
$$H = \frac{\sigma h_0}{\rho_0 \log_{10} e} \{ \log h_0 - \log h \}.$$

In calculating the value of ρ_0 we take the average temperature of the column of air and assume the whole of the air in the column to be at this average temperature.

If the air at the lower station is nearly under standard conditions the value of $\sigma h_0 / \rho_0 \log_{10} e$ will be found to be 2×10^6 centimetres.

Hence we get the following rule for finding the difference in level between two stations.

Multiply the difference between the logarithms of the two barometric readings by two million. The result will be the difference required in centimetres.

Hence since 1 cm. = .03281 feet, if the measurements are made in feet, the coefficient will be $.06562 \times 10^6$ or 65620 feet.

Example. *Work out by the more accurate formula the Example already solved.*

In the Example given on p. 157 we have $h_0 = 751.9$ mm., $h = 633.7$ mm.

The difference between the logarithms is .07428, and the height is therefore 148560 centimetres or 1485.6 metres.

The correct result, allowing for the fact that the mean temperature is 10° C. and the pressure at the bottom 751.9 mm., obtained by using the complete coefficient $\sigma h_0 / \rho_0 \log_{10} e$, is found by multiplying the above value by about 1.05; and comes to be very nearly 1560 metres. Thus the result found by assuming the air to be at standard pressure and temperature is about 74 metres or 5 per cent. too low; that given by the approximate formula on p. 157, is nearly 150 metres or 10 per cent. too low. In any case a correction is needed to allow for the aqueous vapour present. This, assuming the air to be half-saturated, would reduce the height by about 2 parts in 1000, or say 3 metres.

80. Boyle's Law.

The volumes of most bodies can be changed by change of pressure. For solids and liquids, however, this change is extremely small, and, therefore, in dealing with the dilatation of such bodies due to rise of temperature it is not necessary to notice those changes in volume which may be produced by variation of pressure.

A gas, on the other hand, alters in volume considerably for small changes of pressure, even though the temperature remain constant, and we require to investigate first the law which regulates this change. This law, called Boyle's Law, was first enunciated by the Hon. Robert Boyle in 1662.

Boyle's Law. *The pressure of a given mass of gas at constant temperature is inversely proportional to its volume.*

EXPERIMENT 27. *To verify Boyle's Law.*

In Fig. 77 AB , CD are two glass tubes connected by stout india-rubber tubing and fixed to a vertical stand.

AB is closed at its upper end and may be 50 cm. long and $\cdot 5$ cm. in diameter; CD is a wider tube and is open at the top. A vertical scale parallel to the tubes is attached to the stand, and CD can slide up and down this scale. The india-rubber tubing and the lower parts of the glass tubes contain mercury. The upper part of the tube AB is filled with dry air, which constitutes the given mass of air on which the experiment is to be made. The volume of this air is proportional to the length, AB , of the tube which it occupies, and this length can be read off directly on the scale. To find the pressure of the air, let the horizontal line through B meet the mercury in the moveable tube at E , and let D be the top of this mercury column.

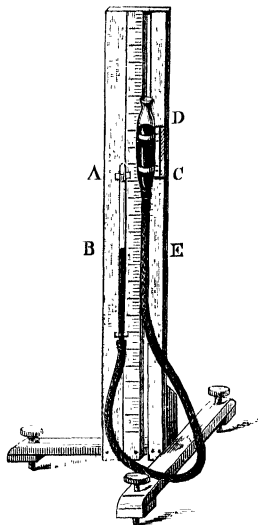

Fig. 77.

Then the pressure at B is equal to the pressure at E , and this is equal to the pressure of the atmosphere at D together with the weight of a column of mercury of unit area and height DE . Thus, if b cm. be the height of the barometer, the pressure at B is measured by a column of mercury of height $b + DE$.

Now, according to Boyle's Law, if the temperature is constant the pressure is inversely proportional to the volume. Hence if the pressure and the volume of the gas in AB be multiplied together the product obtained will be always the same however the pressure be varied.

Raise or lower the sliding tube until the mercury stands at the same level in the two tubes.

Read on the scale the level of the top of the tube AB and the position of the mercury in the tube; the difference will be proportional to the volume of the air. Since the mercury in the two tubes is at the same level the pressure of the enclosed

air is the atmospheric pressure. Observe the height of the barometer, let it be b cm.; the pressure of the enclosed air is measured by a mercury column b cm. in height. Raise the sliding tube. The mercury in the closed tube also rises but not so fast; the volume of the enclosed air is reduced, but its pressure is increased, being now measured by the height of the barometer together with the column of mercury between the two levels. Continue to raise the sliding tube until the mercury in the closed tube reaches a point B_1 , half-way between A and B ; let the level of the mercury in the open tube when this is the case be at D_1 . The volume of the enclosed air is now half what it was. Its pressure is measured by $b + D_1B_1$. Read the levels at D_1 and B_1 , it will be found that D_1B_1 is equal to b , the height of the barometer; hence the pressure of the enclosed air is now measured by $2b$; that is, it is twice what it was originally. The volume has been halved, the pressure has been doubled. Thus Boyle's Law has been verified for this case.

The verification may be made more complete by taking readings of the volume and of the pressure in a number of other positions of the sliding tube.

If B_1 , D_1 be corresponding levels of the two mercury columns, the volume of air is proportional to AB_1 , the pressure to $b + B_1D_1$. Set down in two parallel columns the values of AB_1 , and of $b + B_1D_1$, and in a third column the numbers obtained by multiplying the corresponding values together. It will be found that these products are constant within the limits of experimental error.

The results of the experiments may be entered in a table thus:

Volume.	Pressure.	PV.
50	76	3800
40	76+18.8	3792
30	76+50.5	3795
20	76+113	3780

The same apparatus may be used for pressures less than that due to the atmosphere by lowering the position of the sliding tube until D is below B ; in this case the pressure is given by $b - BD$.

81. Deductions from Boyle's Law.

Boyle's Law may be expressed in symbols in various ways. Thus if p be the pressure, v the volume of a given mass of gas; then, since the pressure is inversely proportional to the volume, we have the result that the ratio of p to $1/v$ is constant; denoting this constant by k we find

$$\frac{p}{\frac{1}{v}} = k.$$

Therefore $p = \frac{k}{v}$,

or $pv = k$.

When we say that k is a constant we mean that it does not change when the pressure and volume are changed, if the temperature and mass of the gas are not varied. When a gas is allowed to expand under the condition that the temperature does not alter the expansion is said to be isothermal. If corresponding values of the pressure and volume are plotted the curve formed is said to be an isothermal curve.

Or again, if the volume v becomes v' , and in consequence the pressure p is changed to p' , since the product of the pressure and volume does not alter we have $pv = p'v'$.

Again, the volume of a given mass of gas is inversely proportional to its density; since, therefore, the volume is inversely proportional to the pressure, we see that the pressure of a gas is proportional to its density; or if ρ be the density, the ratio of p to ρ is a constant. We may write this $p = k\rho$, where k is a constant.

Examples involving Boyle's Law may be worked in various ways. Thus we may use the formula directly as in the following.

(1) *The volume of a mass of gas at 740 mm. pressure is 1250 c.cm., find its volume at 760 mm.*

Let v be the new volume, then from the formula $pv = p'v'$

$$v \times 760 = 1250 \times 740,$$

$$v = 1250 \times 74/76 = 1217.1 \text{ c.cm.}$$

Or we may preferably put the argument in full thus:

Volume at pressure 740 is 1250 c.cm.

Volume at pressure 1 is 1250×740 c.cm.

Volume at pressure 760 is $\frac{1250 \times 740}{760}$ c.cm.

It is of course by no means necessary to measure the pressure in terms of the height of a column of mercury. Thus,

(2) *A bubble of gas 100 c.mm. in volume is formed at a depth of 100 metres in water, find its volume when it reaches the surface, the height of the barometer being 76 cm.*

Since the density of mercury is 13.59 grammes per c.cm., the height of the water barometer is 76×13.59 cm., and this is very approximately 10.34 metres.

Thus the pressure at the surface is measured by a column of water 10.34 metres high, that at 100 metres by a column 110.34 metres.

Hence the new volume = $\frac{100 \times 110.34}{10.34}$ or 1067 c.mm. approximately.

(3) *The mass of a litre of air at 760 mm. pressure and 0° C. is 1.290 grammes. Find the mass of 1 cubic metre of air at a pressure of 1.9 mm.*

The volume of the given mass of air at a pressure of 1.9 mm. is 1000000 c.cm.

Therefore the volume at pressure of 76 cm. is

$$\frac{10000 \times 19}{76} \text{ or } 2500 \text{ c.cm.}$$

The mass of 1 c.cm. air is .001293 grammes.

Therefore the mass of 2500 c.cm. is $2500 \times .001293$ grammes, and this is 3.24 grammes.

82. Variations from Boyle's Law.

More exact experiments have shewn that Boyle's Law is not absolutely true, though for the so-called permanent gases, oxygen, hydrogen, nitrogen and others, it holds very nearly; other gases, such as carbonic acid, which can be condensed to a liquid at ordinary temperatures by the application of a not very large pressure (see *Heat*, § 119), deviate more from the law.

83. Dilatation of Gases by Heat.

The volume of a gas changes considerably with change of temperature. In most of the problems in Hydrostatics we suppose the temperature to be constant. It will be useful, however, to state the law connecting the rise of temperature and the increase of volume, which is due to Charles and Dalton.

Law of Charles and Dalton.

The volume of a given mass of any gas increases for each rise of temperature of 1° by a given fraction (about $1/273$) of its volume at 0° C.

Thus if the volume at 0° C. be v_0 c.cm., the increase for each rise of 1° is $v_0/273$. For a rise therefore of t° the increase in volume is $v_0 t/273$, hence, if v c.cm. be the volume at t_0° , we have

$$\begin{aligned} v &= v_0 + \frac{v_0 t}{273} = v_0 \left(1 + \frac{t}{273} \right) \\ &= v_0 \frac{273 + t}{273}. \end{aligned}$$

The quantity $273 + t$ is called the absolute temperature of the gas, let us denote it by T . Then, if we denote 273 the absolute temperature of the freezing-point by T_0 , the formula becomes

$$\frac{v}{T} = \frac{v_0}{T_0}.$$

Hence the volume of a given mass of gas at constant pressure is proportional to its absolute temperature¹.

It follows from the above two laws that if the pressure, absolute temperature and volume of a gas vary, then pv/T remains constant.

*84. Pressure of a Mixture of Gases.

It can be shewn by experiment that if two gases in different vessels be at the same pressure and temperature, and

¹ For an explanation of the meaning of the term absolute temperature and a description of experiments to verify Charles' Law, see Glazebrook, *Heat*, Sections 98-104.

if a communication be opened between the vessels, then the gases form a mixture in which the pressure is the same as before provided no chemical action takes place. From this result we obtain the following Proposition.

***PROPOSITION 27.** *If the pressures of two gases at the same temperature t° and volume v c.cm. be p_1, p_2 respectively, the pressure of the mixture at the same temperature t° and volume v c.cm. will be $p_1 + p_2$.*

Let the volume of each gas be v .

Change the volume of the second gas until its pressure becomes p_1 ; its volume will be p_2v/p_1 .

Let the vessels containing the two gases, each of which is at pressure p_1 , communicate with each other, the pressure will remain p_1 , the volume of the two gases together will be

$$v + \frac{p_2v}{p_1} \text{ or } \frac{v(p_1 + p_2)}{p_1}.$$

Alter the volume to v , the new pressure will, by Boyle's law, become $p_1 + p_2$.

Thus the Proposition is established.

Examples. (1) *The space above the mercury in a barometer is supposed to contain some air. How would you test for this and how would you determine the correction due to the presence of the air, supposing no other barometer to be available?*

Slightly incline the tube taking care not to spill the mercury from the reservoir, the mercury rises in the tube, and if there be no air present it will when the tube is sufficiently inclined fill it completely; if air is present the mercury will not fill the tube but a bubble of air will be visible between it and the glass. In order to determine the correction without the use of another barometer it is necessary to raise the level of the mercury in the reservoir relative to the end of the tube. If it be possible to do this, Read the barometer and note the distance between the top of the column and the closed end of the tube. Let the height of the barometer be h_1 . Depress the lower end of the tube in the reservoir until the distance between the closed end of the tube and the top of the column which rises in the tube is half what it was. The volume of the air above the column is thus halved, its pressure therefore is doubled. Let p_1 be the pressure due to the air before the tube was lowered, measured in mm. of mercury; after it has been lowered the pressure becomes $2p_1$. Read the height of the barometer column in the second case. Let it be h_2 and let π be the atmospheric pressure both measured in mm. of mercury.

Then in the first case, a column of height h_1 with a pressure p_1 on the top balances the atmospheric pressure; in the second case, the height of the column is h_2 and the pressure at the top is $2p_1$.

Thus
$$p_1 + h_1 = \pi = 2p_1 + h_2;$$
 hence
$$p_1 = h_1 - h_2.$$

This gives the correction when the height of the column is h_1 . Under these circumstances let the length of tube filled with air be l_1 ; then, when owing to a change in the atmospheric pressure the height becomes h and the length above l , the pressure due to the air is, by Boyle's Law, $p_1 l_1 / l$ or $(h_1 - h_2) l_1 / l$.

Thus the true height of the barometer will be $h + \frac{(h_1 - h_2) l_1}{l}$.

(2) According to Mr Whymper's observations the barometer on the top of Chimborazo read 14.1 inches, while that at Guayaquil on the sea-coast below read 30 inches. The mean of the temperatures at the two places was nearly 10°C . Find the height of Chimborazo.

The density of half-saturated air at 10°C . is given by the Tables¹ as .001245 grammes per 1 c.cm., that of mercury is 13.59 grammes per 1 c.cm.

Hence
$$H = \frac{13.59 \times 30}{.001245 \times \log_{10} e} \{\log 30 - \log 14.1\} \text{ inches}$$

$$= .754 \times 10^6 \{\log 30 - \log 14.1\} \text{ inches}$$

$$= 20,600 \text{ feet.}$$

The height given by Mr Whymper as resulting from his observations after inserting all corrections is 20,545 feet.

EXAMPLES.

PRESSURE OF THE ATMOSPHERE.

[For a Table of Specific Gravities see p. 15.]

Mass of a litre of hydrogen at 0°C . and 760 mm. pressure .0896 grammes.

Specific gravity of oxygen referred to hydrogen 16.

Specific gravity of air referred to hydrogen 14.4.

1. The volume of a mass of gas at a pressure due to 76 cm. of mercury is 500 c. cm. Determine its volume at the following pressures: 10 cm. of mercury, 5 inches of mercury, 53 inches of water, 60 fathoms of water.

2. Find the volume at 0°C . of 50 grammes of oxygen at a pressure due to 68 cm. of mercury.

3. Find the mass of 1000 cubic feet of coal-gas at standard pressure and temperature. [Specific gravity of coal-gas referred to air .496.]

¹ Lupton's Tables (36).

4. A balloon 10 metres in diameter is filled with coal-gas at a pressure of 76 cm. of mercury. What is the weight of the balloon and its appendages if it just will not float in the air?

5. The space above the mercury in a barometer tube contains some air and the barometer reads 656 mm. when a standard barometer reads 762. Find in grammes weight per square cm. the pressure of the enclosed air.

6. There is a column of water 9 mm. in height above the mercury in a barometer, the temperature is 15° C. and the pressure of aqueous vapour at 15° C. is 12.7 mm. of mercury; find the correction on this account to the observed reading.

7. How much will a barometer rise on descending a coal-pit 50 yards deep, assuming the average temperature to be 20° C.?

8. Find the true weight of a piece of cork which weighs 75 grammes when weighed with brass weights in air.

9. Two spheres of equal volume when filled the one with air the other with hydrogen and weighed in air are found to be equal in weight, compare the pressures of the two gases.

10. Calculate the height of the mercury barometer corresponding to the following pressures: 10^6 dynes per square cm., 13.5 lbs. weight per square inch, 1500 lbs. weight per square foot.

11. Find the volumes of the following masses of air all at 0° C.:

1 gramme at 76 cm. when the pressure becomes 75.2 cm.,
300 c. cm. at 15 lbs. per square inch when the pressure becomes 76 cm.,
235 cubic inches at 60 feet of water when the pressure becomes 30 inches of mercury.

12. A barometer reads 30 inches and the space above the mercury is 5 inches. If a bubble of air which at normal pressure would occupy 1 inch of the tube is introduced what will the reading become?

13. Find the volume of 2.35 grammes of hydrogen at a pressure of 830 cm. of mercury.

14. If a vessel containing 25 grammes of hydrogen at a pressure due to 25 inches of mercury is allowed to communicate with one containing 2.5 grammes hydrogen at a pressure of 25 feet of water, find the pressure of the mixture when equilibrium is restored.

15. At what depth in water will the density of air be the same as that of water?

16. State Boyle's Law. What is the change in volume of a quantity of air which measures 20 cubic feet if the pressure change from 15 to 10 lbs. per square inch?

17. A bubble of air $\frac{1}{8}$ inch in diameter starts from the bottom of the Atlantic at a depth of two miles. Find its size on reaching the surface.

18. An air-bubble at the bottom of a pond 15 feet deep has a volume equal to $\frac{1}{1000}$ of a cubic inch, find its volume when it reaches the surface, the height of the water-barometer being 30 feet.

19. The volume of a mass of air is increased from 1 to 20 cubic feet; how is its pressure affected?

20. An elastic bag contains 25 cubic feet of air at atmospheric pressure. What will be the volume when sunk 250 feet below the surface of the sea? The height of the water barometer may be taken as 33 feet and the specific gravity of sea water as 1.026.

21. Air is contained in a cubical vessel whose edge is 4 inches long, and the pressure on a face of the vessel is 5 cwt. If air be allowed to escape freely, find the volume of the escaped air if the atmospheric pressure at that time is 15 lbs. to the square inch. [The thickness of the material may be neglected.]

22. A piston whose area is 6 square inches fits into a cylinder containing air at atmospheric pressure, namely 15 lbs. to the square inch. What force must be applied by the hand to the piston in order that the volume of the air in the cylinder may be trebled?

23. The density of air at atmospheric pressure is .00129 grammes per c.cm. How deep must a bladder filled with air be sunk in the sea in order that its density may be equal to that of water, the specific gravity of sea water being taken as 1.025 and the height of the water barometer 33 feet?

24. A litre of air at 0° C. and under atmospheric pressure weighs 1.2 grammes; find the mass of the air required to produce at 18° C. a pressure of 3 atmospheres in a volume of 75 c. cm.

25. Explain how a measurement of the pressure of the atmosphere can be obtained from a reading of the height of the barometer.

Describe any method that you are acquainted with of obtaining an accurate barometer reading.

26. Explain the way in which the height of a mountain may be deduced from barometrical observations.

Shew that as long as the temperature of the air and the amount of aqueous vapour in it remain unaltered the ratio of the heights of the barometer at the top and bottom of the mountain will be constant.

27. Explain carefully why the mercury in a barometer falls in ascending a mountain. At sea level the barometer reads 750 mm.; on going up a mountain the reading falls to 600 mm. Compare the weights of a cubic metre of air in the two positions, the temperature being the same.

28. What experiments would you perform to shew that the height of the barometer measures the pressure of the atmosphere?

29. In a barometer with long vertical cistern the height of the mercury is 29 inches. When the tube is depressed so that the space above the mercury (which contains air) is reduced by one-half, the height of the mercury is 28 inches. What is the pressure of the atmosphere?

30. A certain bottle, which has an outlet at the bottom fitted with a tap, is nearly filled with water and is closed with an air-tight stopper. When the tap is turned on, the water runs out, at first quickly, then more and more slowly and at last not at all, though there still remains water in the bottle. Explain this and state what difference of pressure exists between the air in the bottle and that outside, when the flow has ceased.

31. What adjustments have to be made before reading the standard barometer, and what corrections have to be applied afterwards?

32. Find the height of the homogeneous atmosphere at a temperature of 15° C. when the height of the mercury-barometer is 750 mm. The specific gravity of mercury is 13.56, and that of air at 0° C. and 760 mm. 001293.

33. Describe an experiment to prove that the pressure of the atmosphere is measured by the height of a barometer column. Find the height between two stations, having given the following data :

Density of mercury 13.6 grammes per c. cm.

Mean density of air between the two stations 0.00121 gramme per c. cm.

Height of barometer at lower station 785 mm.

" " " " upper " .630 " .

34. The height of the Torricellian vacuum in a barometer being 3 inches, the instrument indicates a pressure of 29 inches when the true pressure is 30 inches. Assuming that the faulty readings are due to the pressure of some air in the Torricellian vacuum, shew that the true reading corresponding to any faulty reading h is

$$h + \frac{3}{32 - h}.$$

35. A barometer which is known to have some air above the mercury is constructed so that the tube can be depressed into the cistern, thus varying the volume of the tube above the mercury column. When the top of the column is 6 inches below the top of the tube the barometer reads 30 inches. On depressing the tube 3.5 inches the barometer reading is reduced to 29.5 inches. Find what the reading would be if there were no air above the mercury.

36. A bent uniform tube has two equal vertical branches close together, one end being open and the other closed. Mercury is poured into the open end, no air escaping. If when the mercury just fills the open tube the air occupies two-thirds of the closed branch, prove that the length of either branch is equal to three times the height of the mercurial barometer.

CHAPTER VIII.

HYDROSTATIC MACHINES.

85. The Pipette.

This instrument is shown in fig. 78. It consists of a glass tube with a bulb blown on to it about one-half of the way down; the lower end of the tube is drawn out to a point and ends in a small orifice. It is used for removing liquid from one vessel to another. The lower end is placed in the liquid, which is drawn up into the pipette by suction at the top. When there is a sufficient quantity in the bulb the mouth is removed and the upper end closed with the finger. The lower end is then withdrawn from the vessel and the atmospheric pressure acting at the orifice is sufficient to retain within the bulb the liquid it contains. The lower end is then placed in the vessel to which the liquid is to be transferred and the finger removed from the top; the liquid then flows out, and its flow may be hastened by blowing into the upper end.

In some cases pipettes are constructed to hold measured quantities, 10, 25 or 50 c.cm. of liquid. A mark is made on the upper part of the tube, and the volume, when the instrument is filled up to the mark, is indicated on the bulb.

86. The Siphon.

This is an instrument by means of which we can empty a vessel filled with liquid without moving the vessel.

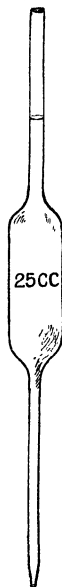

Fig. 78.

It consists of a bent tube ABC , Fig. 79, open at both ends, one limb being longer than the other. It is filled with water or whatever liquid the vessel to be emptied contains; the ends are then temporarily closed with the fingers and the shorter limb AB is placed below the surface of the liquid in the vessel it is desired to empty.

The other end C is outside the vessel and below the level of the liquid surface. On opening the ends at A and C , the liquid flows through the siphon from A to C , as shewn in the figure.

To explain the action of the siphon, let us suppose it to be filled with liquid and the end C closed. Let it cut the surface of the water in the vessel in D and let DE be horizontal. Let us consider the forces acting on the column of liquid EC .

Since D and E are points in the same horizontal plane in a liquid at rest, the pressure at E is equal to the pressure at D .

But the pressure at D is the atmospheric pressure; hence the pressure at E is the atmospheric pressure acting downwards on the column EC .

Thus the downward forces on EC are the thrust at E due to the atmospheric pressure acting on the area of the top of the column, and the weight of the column; these forces are balanced by the upward thrust exerted by the finger at C which closes the end of the tube, this upward thrust then must be greater than that due to the atmospheric pressure acting on the end of the column EC .

If the end C be opened the pressure at C becomes equal to the atmospheric pressure, thus at the moment of opening the column EC is acted on downwards by the thrust due to the

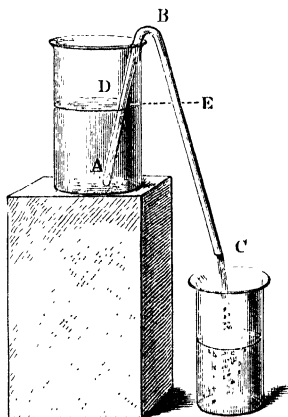

Fig. 79.

atmospheric pressure at E and its weight, and upwards by the thrust due to the atmospheric pressure at C .

This upward thrust is too small to balance the downward thrust and the column EC begins to move downwards. The pressure at E is thereby lessened, and if we now consider the column DBE , the upward thrust at D on this column becomes greater than that at E and the liquid is forced from the vessel A through the siphon.

In passing from A to C the liquid loses potential energy, being carried from a higher to a lower level, and hence this motion takes place.

It is clear from the proof that, if C be above D , the level of the water in the vessel, the siphon will not work; on opening the end C the water in the tube would flow back into the vessel.

Again, it is also clear that the height BD must not be greater than the barometric height of the liquid to be emptied. For the column BD is supported in the tube by the atmospheric pressure on its base; if then BD be greater than the barometric height, some of the liquid will run back into the vessel A until the height of the column of liquid in BD is just equal to the barometric height. In this case, when C is opened, the liquid in BC will run out until the upper free surface of the column in BC is at the barometric height above C .

The final condition will depend on various circumstances; it is quite possible that the momentum acquired by the column in BC may be sufficient to carry the whole of the column out of the tube, or again some portion of the column may run out and then the atmospheric pressure acting on the lower end of the column may force it back up the tube until it joins the column in the other limb and then the whole of the liquid in the tube will flow back into the vessel A .

For convenience in filling, the siphon is often made in the form shewn in Fig. 80, the lower end is closed and the liquid is drawn from the vessel by suction at the side tube.

87. Experiments with the Siphon.

An experiment due to Pascal illustrates the action of the siphon. A three-armed glass tube of the form shewn, ABC ,

Fig. 81, is employed. The two lower arms dip into two vessels of mercury, the arm *C* being longer than the arm *A*.

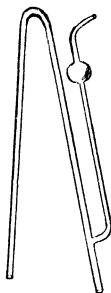

Fig. 80.

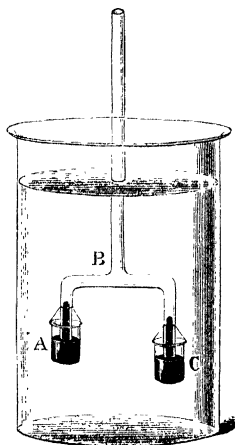

Fig. 81.

The whole apparatus is immersed in a deep vessel of water, the arm *B* being kept open to the atmosphere. As the tubes are lowered, the water pressure forces the mercury up the tubes *A* and *C* until the column in the shorter tube rises to its top, runs along the horizontal tube and joins the column in the tube *A*; thus a continuous column of mercury is formed from *A* to *C*. When this has taken place the tube *A* to *C* forms a siphon and the mercury flows from *A* to *C*.

88. The Syringe.

This instrument is the simplest form of pump for raising water. It consists of a hollow cylinder *AB*, Fig. 82, in which a solid air-tight piston works; the lower end of the cylinder terminates in a nozzle *C*, which is placed under the liquid it is desired to raise.

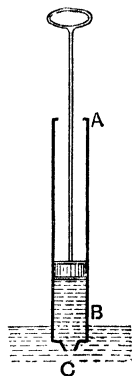

Fig. 82.

Let the syringe, with the piston at the bottom

of the tube, be placed in the liquid; if the piston be now raised, the atmospheric pressure, acting on the upper surface of the liquid, forces it through the nozzle into the cylinder to fill the vacuous space which would otherwise be formed under the piston. Thus as the piston is raised the liquid flows into the cylinder after it.

The syringe and the various forms of pump act by the principle of suction; this consists in enlarging the volume of a space to which the liquid has access; the pressure within the space is thus reduced and the atmospheric pressure forces the liquid into the space until equilibrium is again established. In this way air is sucked into the lungs; the muscles of the chest cause the lungs to expand; the internal pressure is thereby reduced and the air passes in. The act of drinking water through a tube is similar. The drinker causes the air in his mouth and the upper part of the tube to expand and then the atmospheric pressure drives the water up.

89. Valves.

In most hydrostatic machines valves are employed. A valve may be described as a trap-door which will open in one direction only; it will thus yield to an excess of pressure on one side and, opening, will allow the passage of fluid; an excess of pressure in the other direction will close the valve and stop the flow of the fluid.

A simple form of valve is the hanging flap valve; it is a flat disc which turns about a hinge in its upper edge and thus opens or closes a passage. In the ordinary bellows the flap is a piece of leather; this is raised when the bellows are expanded and allows the air to enter. On compressing the bellows the leather disc is driven against the opening it covers and the air is forced through the nozzle.

The ball-valve is another form in use. A metal sphere fits accurately over the opening of a pipe through which the fluid is to pass, when fluid is forced along the pipe the sphere is raised and it passes out; pressure in the other direction only drives the sphere more closely against its seat. The sphere is constrained by suitable guides, so that it can only rise and fall and not move far from the orifice it is to close.

A form of valve used in many air-pumps is shewn in

is again lowered the water passes through the piston-valve and is raised at the next stroke to the valve E . The pressure opens this valve and the water passes on up the tube EF . When the piston is again depressed the valve E is closed by the water-pressure above and remains closed until the next upstroke, when it is again opened and more water is lifted up the tube EF . The process thus continues; the height to which the water can be lifted depends only on the force applied to the pump-handle and the strength of the pump.

The force on the piston until the water has reached the tube EF is given by the same expression as that found for the common pump. When the water has been raised into the tube EF , let h' be the head of water above the piston. Then the force on the upper side of the piston is $(H+h')A$ grammes weight, that on the lower side acting upwards is $(H-h)A$ grammes weight, h being the height of the piston above the well.

Thus the resultant downward force is

$$(H+h')A - (H-h)A \text{ or } (h'+h)A \text{ grammes weight.}$$

It is thus the weight of a column of water, having the area of the piston for its base and the total height to which the water has been raised for its height.

The rise of the water for a single stroke can also be found.

92. Force-pump.

This consists of a cylinder AB with a solid piston or a plunger H , working in an air-tight collar, as in Fig. 85.

At the bottom of the cylinder there is a valve F opening upwards. A tube CE rises from close to the bottom of the cylinder and is closed with a valve C opening outwards from the cylinder.

Suppose that the piston is initially at the bottom, let it be raised; the pressure in the cylinder is diminished, the atmospheric pressure closes the valve C , the valve F is opened and air passes in from the pipe BD , thus reducing the pressure in the pipe at D . The atmospheric pressure forces the water up the pipe DB . As the piston descends the valve F is closed while C is opened and the air is forced from the cylinder up the tube CE .

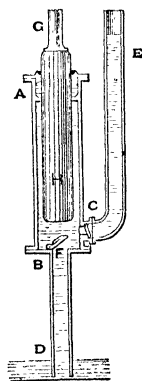

Fig. 85.

This process is repeated until the water rises into the cylinder above the valve F' ; at the next downstroke the water is forced through the valve C and up the tube CE . When the piston again rises the water-pressure in CE closes the valve C . More water is forced up the pipe through the valve F' to be forced up the tube on the next downstroke. Thus the height to which the water can be forced depends on the force applied at the handle and the strength of the pump.

The force on the piston rod during the upstroke is found in the same way as for the common pump, Section 90.

During the downstroke the force will depend on the height to which the water has been raised in the tube CE . This force must clearly be applied downwards, and if A be the area of the piston, h' the height of the water in CE above the bottom of the piston, the force is Ah' grammes weight.

In all three pumps it is necessary that the height of the valve at the bottom of the cylinder above the water in the well should be less than the height of the water-barometer; in practice it is found that this height must be considerably less because of the imperfection of the valves.

93. Continuous action pumps. The fire-engine.

In the pumps just described the action is discontinuous; in the first two, the water only flows from the spout during the upstrokes; in the last the flow occurs only during the downstroke. In some pumps this is remedied by the introduction of an air chamber. The water is forced into a closed chamber A , Fig. 86. From the lower part of this chamber a pipe BD passes through the top of the chamber to the spout. When the water is first pumped into the chamber it rises above the open end of the pipe BD , enclosing a quantity of air in the upper part of the chamber. This air is compressed by the water which, when the piston is being rapidly lowered, enters the chamber with considerable velocity. As the piston is raised, and the valve C is closed,

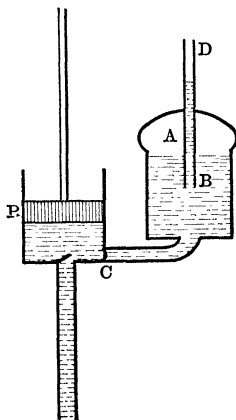

Fig. 86.

the air in *A* expands, thus driving the water, which otherwise would cease to flow, up the tube *BD*. Energy is stored up in the compressed air during the downward stroke, this is used to raise the water during the upward stroke.

The hand fire-engine consists of two force-pumps connected to a common air chamber. The handles of the pumps are so arranged that while one descends the other rises.

94. Bramah's Press.

The principle of this apparatus has already been described as an illustration of the transmissibility of pressure and was known to Pascal. Two cylinders filled with fluid and fitted with pistons of different areas are connected together, thus a small force applied to the small piston enables the large piston to exert a much greater force.

The invention was however useless for very many years because of the difficulty of rendering watertight the apertures through which the piston rods work. Bramah overcame the difficulty by his invention of the cupped leather collar. A leather ring, semicircular in section, fits round the pistons in a groove in the sides of the cylinder. The concavity of the ring is turned downwards and water passing between the

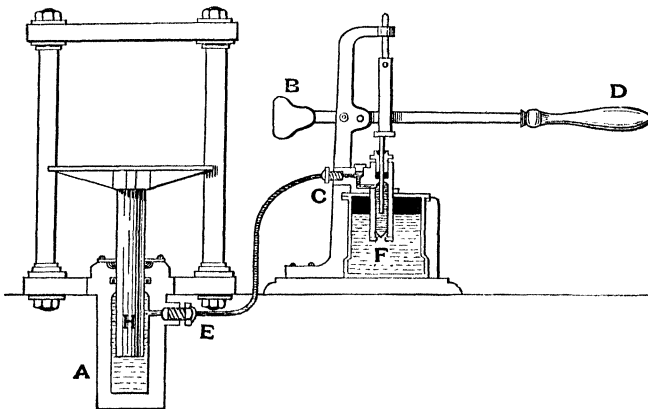

Fig. 87.

piston and the sides of the cylinder fills the hollow under the ring, and by its pressure forces the ring against the sides of the piston, thus forming a packing which becomes more tight as the pressure increases.

The press is shewn in Fig. 87 and the collar in Fig. 87 *a*. A small solid plunger is worked by the handle *D*; this as it rises draws liquid through a valve shewn at *F* from a reservoir. When the plunger descends the liquid is forced into the large cylinder *A* through a valve opening into the tube *CE*. The pressure at each point of the liquid in *A* is then the same as in the small cylinder, and since the area of the plunger *H* is much greater than that of the other plunger, the upward thrust exerted on *H* is greater than the downward thrust exerted by the small plunger. The force is applied to the small plunger by the lever *BD*. By shifting a pin on which this lever works, its shorter arm can be considerably reduced and greater mechanical advantage obtained

Fig. 87 *a*.

Let *P* be the force applied to the lever, and *m* its mechanical advantage. Let *a* be the area of the small plunger, *A* that of the large.

The downward thrust on the small plunger is *mP*, this is applied over an area *a*; the pressure therefore in the fluid is mP/a . This pressure is transmitted to each unit of area of the large plunger; thus the upward thrust on the large piston is mPA/a .

Hence the mechanical advantage of the whole instrument is mA/a . Thus if the long arm of the lever be 10 times that of the short, and the area of the large plunger 100 times that of the small, conditions which might easily occur in practice, the value of A/a is 100 and the mechanical advantage is 1000. Any force applied at *D* is multiplied one thousand times by the machine.

*95. Work done in a Press.

It follows from the principle of work that, in order to raise a weight through a given distance by such a press, the small

plunger will have to move over 100 times that distance and the handle of the lever over 1000 times the distance.

We can easily shew that this is true thus. Let the end of the small plunger descend a distance x while the large plunger rises a distance X .

Then the volume of the water in the small cylinder is decreased by $a \cdot x$, that in the large cylinder is increased by $A \cdot X$. But these expressions must be equal since each is the volume of water forced from one cylinder to the other.

$$\text{Therefore} \quad AX = ax.$$

$$\text{Thus} \quad X = x \frac{a}{A} = \frac{x}{100}$$

if the ratio of the areas of the plungers be 100 to 1.

Again, if y represent the distance traversed by the handle when the plunger descends a distance x , then $y = mx$.

$$\text{Hence} \quad X = x \frac{a}{A} = y \frac{a}{mA} = \frac{y}{1000}$$

if $A/a = 100$ and $m = 10$.

Examples. (1) *The lower valve of a common pump is 10 feet above the water and the area of the cylinder is four times that of the pipe leading to the well. Assuming the height of the water-barometer to be 33 feet, find the length of stroke if the water just rises to the valve at the end of the first upstroke.*

Let the stroke be x feet and let w be the weight of a unit of volume of water and a the area of the lower pipe.

The volume of the air in the pipe originally is $10a$ c. feet, and its pressure is $33w$.

After one stroke its volume is $x + 4ax$ c. feet, and its pressure $(33 - 10)w$.

Now the product of the volume and pressure is constant by Boyle's Law.

$$\text{Hence} \quad 10a \times 33w = 4xa \times 23w.$$

$$\text{Therefore} \quad x = \frac{10 \times 33}{4 \times 23} = 3.59 \text{ feet.}$$

(2) *A force-pump is used to draw water from a depth of 5 metres and drive it to a height of 20 metres, the diameter of the plunger is 25 cm.; find the force on the piston rod in the back and forward stroke.*

The area of the plunger is $\frac{1}{4}\pi \times 625$ sq. cm.

During the back stroke the pressure on the piston is less than that outside by that due to 5 metres of water. The force on the piston therefore is $500 \times \frac{1}{2} \pi \times 625$ grammes weight¹ or 2.454×10^6 grammes weight.

In the forward stroke the pressure in the cylinder exceeds that outside by that due to 20 metres of water. The force therefore is four times as great as previously and acts in the other direction.

It is therefore 9.816×10^6 grammes weight.

(3) *The stroke of a common pump is 8 inches, the diameter of the barrel 4 inches, that of the pipe 1 inch. The lower valve is 15 feet above the reservoir. How high does the water rise on the first stroke, assuming the height of the water-barometer to be 30 feet?*

Let the water rise x feet.

Initially the volume of air in the pipe is $\frac{1}{2} \pi \times 1^2 \times 15 \times 12$ c. inches, and its pressure is that due to 30 feet of water. At the end of one stroke the volume is $\frac{1}{2} \pi \{1^2 \times (15 - x) 12 + 16 \times 8\}$ c. inches, and the pressure is that due to $30 - x$ feet of water. Therefore by Boyle's Law,

$$\frac{1}{2} \pi \times 15 \times 12 \times 30 = \frac{1}{2} \pi \{(15 - x) 12 + 16 \cdot 8\} (30 - x).$$

$$\text{Therefore} \quad 15 \cdot 3 \cdot 30 = \{(15 - x) 3 + 4 \cdot 8\} (30 - x).$$

$$\text{Hence} \quad 3x^2 - 167x + 960 = 0$$

and $x = 6.5$ approximately.

Thus the water rises about 6.5 feet.

(4) *In a Bramah press the diameter of the ram is 20 inches, that of the piston 2.5 inches. What force must be applied to the piston to raise 1000 tons weight?*

The areas of the ram and the piston are $\frac{1}{2} \pi \times 400$ and $\frac{1}{2} \pi \times 6.25$ square inches respectively.

Thus the force required is $1000 \times 6.25/400$ or 15.625 tons weight.

(5) *If A be the area of the cross section of the piston of a force-pump, l the length of the stroke, n the number of strokes per minute and B the area of the pipe from the pump. Find the mean velocity with which the water runs out.*

At each stroke a volume $A \cdot l$ of water is transferred to the pipe, the length of this when in the pipe is Al/B . Hence the length of the column transferred to the pipe per minute is nAl/B . Hence a particle which was at the valve when a stroke began has at the end of 1 minute moved a distance nAl/B . This length then measures its velocity per minute.

¹ Strictly the force on the piston will alter slightly with its position in the cylinder; it is assumed that the length of stroke may be neglected compared with the heights the water is raised.

pressure inside the barrel, and since the air in the receiver escapes into the barrel by raising the valve *B* its pressure can never be less than this limiting pressure of the air in the barrel.

When the piston is being raised the downward thrust which is being overcome is that due to the atmospheric pressure, the upward thrust is that due to the pressure of the air in the receiver; when the exhaustion is considerable the difference between these two will be great and towards the end of the exhaustion the full atmospheric pressure of about 1 kilogramme weight per square centimetre of the piston has to be overcome; when the piston is descending this same force presses it down. Thus a considerable amount of energy is spent uselessly in securing the exhaustion.

97. Smeaton's Air-pump.

This consists of a cylinder or barrel in which a piston with a valve opening upwards works; the cylinder is closed at both ends. One end communicates with the receiver through a tube, and the tube is closed by a valve opening into the cylinder, the other communicates with the atmosphere through a valve opening outwards¹.

On raising the piston, the piston valve is closed and the air above forced out through the upper valve. The pressure below the piston is diminished and the air from the receiver opens the lower valve and expands into the barrel. On lowering the piston both the cylinder valves are closed, the piston valve is opened and the air below the piston passes above. At the next stroke this air is expelled through the upper valve, and more air is drawn from the receiver to fill the barrel; the process is then repeated.

This pump has two advantages over Hawksbee's. In the first place until the upper valve is opened the pressure on the upper side of the piston during the upstroke is less than the atmospheric pressure; thus less force is required to raise the piston; while during the downstroke the difference of pressure between the two sides of the piston is very small.

Secondly, when the piston is at the bottom of the barrel after a few strokes the pressure of the air above the piston is very small instead of being as in Hawksbee's pump the atmospheric pressure; hence the pressure of any air which is left in the clearance space below the piston is small and the exhaustion can be made more complete.

¹ The pump is thus the same as Hawksbee's except that the communication with the atmosphere is through the last valve.

98. Double-barrelled Pump.

This is shewn in Fig. 89. In the ordinary pump no air is exhausted during the downstroke; in the double-barrelled

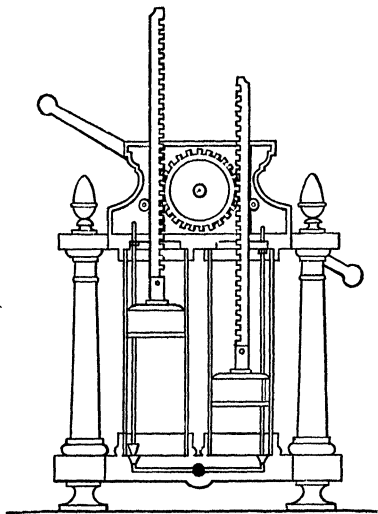

Fig. 89.

pump there are two cylinders and pistons. These are connected together by racks and a pinion, so that while one piston is rising the other is falling; thus air is exhausted during each stroke. Moreover since the atmospheric pressure tends to depress each piston equally, its effect on the one piston which is rising is just balanced by that on the other, which is descending. Less force therefore is necessary to raise the piston than in the ordinary pump; this compensation, it should be observed, does not exist throughout the stroke, for the pressure under the descending piston is continually increasing and when the piston-valve is open the atmospheric pressure on the other piston is entirely unbalanced. As the exhaustion proceeds the compensation at all parts of the stroke becomes more complete, and the pump is easier to work.

99. Tate's Air-pump.

This, which is a very usual form, is shewn in Fig. 90, and in section in Fig. 91. A double piston, P, P' , works in the

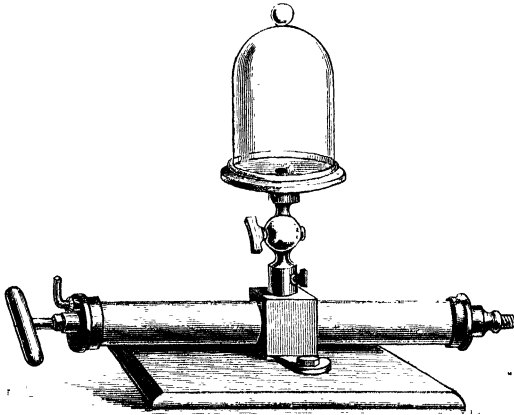

Fig. 90.

barrel AB^1 . At A and B are valves opening outwards. The construction of these is shewn in Fig. 91 (*a*). The pipe

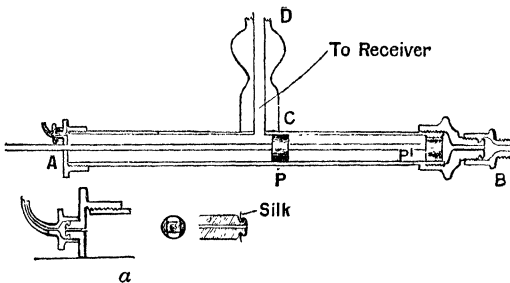

Fig. 91.

CD leads to the receiver. In the figure the portion AP of the barrel is in communication with the receiver.

¹ In some cases the piston is a solid plunger.

When the piston is drawn back the air in AP is compressed, the valve at A is opened by the pressure and the air is expelled. The distance between the pistons is such that, when P is brought home, the piston P' just comes to the left of CD , so that the receiver is now in communication with the other end of the barrel, and some of the air which it contains expands into the barrel. On pushing the piston back the air which has entered BP' is shut off from the receiver, compressed and expelled through the valve B . Thus the receiver is exhausted. The advantage of the pump lies in the fact that the valves in the piston and in the tube from the receiver are both dispensed with, hence the leakage is reduced.

100. Air-pumps. General Considerations.

PROPOSITION 28. *To determine the density of the air, after any number of strokes of a single barrel air-pump, in terms of its initial value and of the volumes of the barrel and the receiver.*

Let V be the volume of the receiver, v of the barrel, ρ the original density, $\rho_1, \rho_2 \dots \rho_n$ the density after 1, 2... n upstrokes.

After one upstroke the air in the receiver occupies the receiver and the barrel; its volume therefore changes from V to $V + v$ and its density from ρ to ρ_1 . The mass of air however is unchanged and the mass is equal to the product of the volume and the density.

$$\text{Thus} \quad (V + v)\rho_1 = V\rho$$

$$\text{or} \quad \rho_1 = \frac{V}{V + v}\rho.$$

On the next downstroke the air is divided into two parts, a mass $v\rho_1$ escapes, a mass $V\rho_1$ is retained in the receiver. After a second upstroke this last mass fills the receiver and the barrel; its density is then ρ_2 and its volume $V + v$.

$$\text{Hence} \quad (V + v)\rho_2 = V\rho_1.$$

$$\text{Therefore} \quad \rho_2 = \frac{V}{V + v}\rho_1 = \left(\frac{V}{V + v}\right)^2\rho.$$

Proceeding thus we see that the density after any stroke is found by multiplying the density before the stroke by the proper fraction $V/(V + v)$.

Thus, after n strokes, we have

$$\rho_n = \frac{V}{V+v} = \rho_{n-1} = \dots = \left(\frac{V}{V+v}\right)^n \rho.$$

Hence, when n is large, the density is very considerably diminished and, if the law were to hold continuously, could be made as small as we please by sufficiently increasing the number of strokes. As we have seen however in practice, this condition cannot be realized because of the necessity of leaving clearance spaces and of the imperfection of the valves.

Since the pressure of air at a constant temperature is always proportional to its density we may write in place of the above equation

$$p_n = \left(\frac{V}{V+v}\right)^n p,$$

where p_n is the pressure after n strokes and p the original pressure.

101. Measurement of the Pressure of the Air in a Receiver.

The pressure of the air in a receiver is measured experimentally by the use of one or other of the gauges described in Sections 36-39. For fairly high exhaustions a vacuum siphon gauge, Fig. 31, is usually employed. If it be desired to watch the effect of each stroke on the pressure, the vertical tube shewn in Fig. 32 is convenient. The top of the tube is connected with the receiver and the height of the column is measured after each stroke. The differences between the height of the barometer and these heights give the pressures.

Examples. (1) *The capacity of the barrel of a Smeaton's air-pump is $\frac{1}{3}$ th of that of the receiver; determine the pressure after five strokes.*

Let the volume of the barrel be v , then that of the receiver is $9v$. Thus a mass of air which occupies $9v$ c.cm. before any stroke occupies $10v$ c.cm. at the end of the stroke. At each stroke therefore the pressure is reduced in the ratio 9 to 10. Thus after five strokes it becomes $\left(\frac{9}{10}\right)^5$ of its initial value.

Now $(.9)^5$ is approximately .59. Hence the pressure is reduced to about .59 of its original value.

(2) *How many strokes must be made with the same pump to reduce the pressure to .1 of its original value?*

Let the number of strokes be n , then after n strokes the initial pressure p is reduced to $(.9)^n p$.

$$\text{Hence} \quad .1 = (.9)^n.$$

We can find a value for n by trial.

$$\text{Thus for } n=5, \quad (.9)^5 = .59.$$

$$\text{Hence } n=10, \quad (.9)^{10} = (.59)^2 = .35 \text{ approximately,}$$

$$n=20, \quad (.9)^{20} = (.35)^2 = .12 \text{ approximately.}$$

$$\text{Thus for } n=21, \quad (.9)^{21} = .12 \times .9 = .108,$$

$$n=22, \quad (.9)^{22} = .108 \times .9 = .0972.$$

Hence during the twenty-second stroke the pressure will reach the required value.

But we can find the result more readily by the use of logarithms, thus

$$.1 = (.9)^n,$$

$$\log (.1) = n \log (.9),$$

$$n = \frac{\log .1}{\log .9} = \frac{-1}{-.016} = \frac{1000}{46} = 21.16,$$

giving the same result as above, viz. that during the twenty-second stroke the required value is attained.

(3) *The capacity of the receiver of a Smeaton's pump is nine times that of the barrel. At what point in the sixth upward stroke will the upper valve open?*

When the piston is at the bottom, after five upward strokes, the pressure of the air in the barrel is .59 of the atmospheric pressure (see Example 1).

As the piston rises during the sixth stroke the air is compressed, and it must be compressed to .59 times its original volume to increase the pressure up to that of one atmosphere. Thus the piston must complete $1 - .59$ or .61 of its stroke.

(4) *In one air-pump the barrel has $\frac{1}{10}$ th of the volume of the receiver, in another it has $\frac{1}{4}$ th. How many strokes of the latter are needed to produce the same exhaustion as that due to four of the former?*

In the first pump the density is reduced by each stroke in the ratio 10 to 11. Thus after four strokes the density becomes $(10/11)^4$ or .682 of its former value.

In the second pump the reduction for each stroke is $5/6$ or .833. Thus after two strokes the density becomes $(.833)^2$ or .694 of its former value and hence two strokes of the second are rather less effective than four of the first.

102. Mercury Air-pumps.

When working with the air-pumps which have been described it is impossible, because of leakage and the necessity for clearance space, to secure a very high vacuum. Various forms of mercury-pump have however been invented, in which the exhaustion can be carried to a much higher degree of exhaustion. Sprengel's pump and Geissler's pump well illustrate two types of mercury-pump.

*103. Sprengel's Air-pump.

This consists of a vertical glass tube BC , Fig. 92, the lower end of which dips under mercury in a vessel G .

The upper end is connected with a reservoir E which can be filled with mercury. At B a branch tube, BD , is inserted; this communicates with the vessel to be exhausted. The height, BG , is greater than that of the mercury-barometer. The reservoir E is usually connected with the vertical tube by a short piece of flexible tubing which can be closed by a clamp F .

Let us suppose also that it is possible to close the tube to the receiver, by a tap or second clamp D , and let this tap be closed. Release the clamp F ; mercury will run down the tube BC carrying the air before it and will completely fill the tube. Close the clamp F . The atmospheric pressure will sustain a column of mercury equal in height to that of the barometer in the tube BC . Above this column there will be a vacuum. Now open D . Air from the receiver expands

into this vacuum, the mercury column falls somewhat and the pressure in the receiver is reduced. Close D and open F ; the stream of mercury down BC carries the air again out of that tube and, on closing F , the mercury stands at the barometric height. Again open D ; more air enters BC from the receiver and this, on closing D and opening F , can again be removed. This description may serve to explain the action of the pump, but, in practice, the tap D is unnecessary and

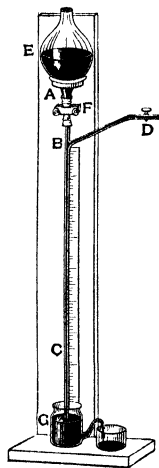

Fig. 92.

the clamp *F* is only used to stop the flow when the receiver is sufficiently exhausted. It is found that if the receiver is permanently connected to the vertical tube *BC* and the clamp *F* is opened, the process described goes on in a partial manner continuously. The mercury column descending from *E* breaks into drops at *B*; as the pressure in *BC* is reduced, through the air being carried down by the mercury, the air from the receiver expands into the tube and is carried down between the drops. There is no need therefore alternately to open and close the tap *D*; hence it may be removed and the risk of leak which it gives rise to may thus be avoided. The process continues until the degree of exhaustion in the receiver is comparable with that of a Torricellian vacuum.

As the mercury from the reservoir *E* flows away, it is replaced by mercury overflowing from *G*, which is caught in a suitable vessel at one side.

In the more modern forms of Sprengel's pump, which are used for exhausting the bulbs of incandescent lamps and other work needing a very high exhaustion, the tube *ABC* is bent in the manner shewn in Fig. 93. The efficiency of the pump is thereby increased.

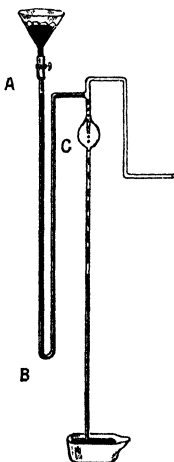

Fig. 93.

*104. Geissler's Air-pump.

This pump in its simplest form consists of two glass reservoirs of considerable capacity. One of these *A*, Fig. 94, is fixed, the other, *B*, can be raised or lowered at will; the two are connected by a piece of stout india-rubber tubing.

The moveable reservoir *B* is open to the atmosphere, while *A* can be put into communication with the atmosphere through a tube which enters at its top; the tube is closed by a tap *C*. A second tube, connected to *A*, communicates with the receiver to be exhausted through a pipe, which can be closed by a second tap *D*. The reservoir *B* when in its lowest position is filled with mercury. Close the tap *D* and open *C*. Raise *B* slowly until it is at a slightly higher level than *A*. The mercury passes from *B* into *A*, driving the air out until *A* is filled with mercury up to the level of the tap *C*, all the air being expelled. Close the tap *C* and lower *B*; the mercury passes back into *B* and stands at the barometric height in the tube between the two reservoirs. Now open the tap *D*. The air from the receiver expands into *A* and the pressure in the receiver falls. Close *D* and raise the reservoir *B*, the air which now fills *A* is compressed by the mercury as it rises into *A*; when the mercury is nearly at the same level in the two, indicating that the air above the mercury in *A* is at atmospheric pressure, open the tap *C* and continue to raise *B* until the mercury in *A* rises again to *C*. Then close *C* and repeat the process. In this way the air is drawn from the receiver and a high degree of exhaustion is attained.

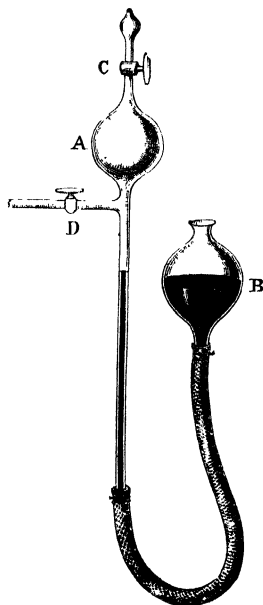

Fig. 94.

In the form of pump just described the tap *D* is a source of difficulty. It is nearly impossible to make the fit so good that there shall be no leak when the tap is turned, and thus the vacuum which can be obtained is impaired.

*105. Tople's Air-pump.

In Tople and Hagen's modification, Fig. 95, the taps are done away with.

Communication is made with the receiver which is to be exhausted through a long inverted U-tube *HDE* which enters at the bottom of the reservoir *A*. The height of *D* above the top of the reservoir is greater than that of the barometer. To reduce the risk of fracturing the pump, by a sudden inrush of air from the receiver when the mercury in the reservoir falls below the level of the tube *DH*, a side tube connects *C* the top of the reservoir to the point *H* just above the junction of the reservoir *A* and the inverted U-tube *DH*. From the top of the reservoir a tube *CFG* bent twice at right angles runs downwards and ends, either under mercury in a small vessel, or in a siphon bend as shewn in the figure. The distance of the bottom of this bend below *C* is greater than the barometric height.

As the vessel *B* is raised the mercury in its ascent closes the mouth of the tube *HDE* and thus shuts off the air in the receiver from that in the reservoir *A*. The air in *A* is then compressed, and finally by raising *B* until the mercury begins

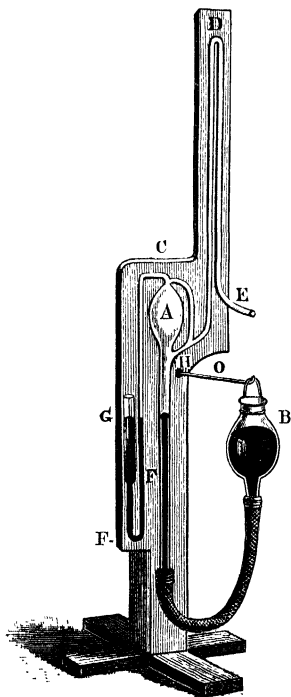

Fig. 95.

to flow over into CFG it is expelled through this tube. The vessel B is then lowered. The atmospheric pressure forces mercury from the siphon bend up FC , but since CF is greater than the barometric height the mercury does not reach C and the reservoir A is completely shut off from the atmosphere. A vacuum is thus formed in the reservoir A until the level of the mercury it contains falls below the point H where the tube from the receiver enters, when this is the case, air enters from the receiver. The process is then repeated.

It is necessary that DH should be greater than the barometric height for, as the vessel B is raised, the air-pressure on the surface of the mercury in B forces mercury up the tube DA and, when the exhaustion is considerable, this mercury will rise to very nearly the barometric height above the level of C .

In using the pump the vessel B can be raised and lowered by hand, in general however some mechanism for doing this is attached to the stand of the pump.

106. The Condenser or Compressing Syringe.

This is an air-pump arranged to compress air into a vessel.

A piston P with a valve E opening into the barrel works in a barrel AB , Fig. 96 (*a*). The vessel into which the air is to be

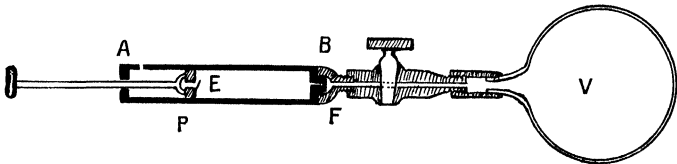

Fig. 96 (*a*).

compressed communicates with the end of the barrel through a tube. This tube is closed by a valve F opening outwards from the barrel. There is also usually a stopcock in the tube so that communication between the vessel and the air may be cut off at will. Let the piston be at the end of the barrel near the valve F . On withdrawing it the pressure in the barrel is reduced; the atmospheric pressure opens the valve E and the barrel is filled with air at atmospheric pressure. The piston is then depressed, the valve E is closed and F is opened:

hence all the air from the barrel is forced into the vessel; on again withdrawing the piston the process is repeated. At each downstroke a barrelful of air at atmospheric pressure is forced into the vessel.

A form of condensing pump used for the tyres of bicycle wheels is shewn in Fig. 96 (b). The piston rod DC is hollow

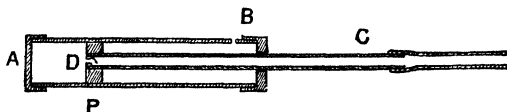

Fig. 96 (b).

and contains a valve at D . At C there is communication with the tyre. When the piston is pressed up against the end of the cylinder at B air can enter the cylinder behind the piston through the aperture B . The cylinder is then pushed forward and the piston moves past the aperture B , thus cutting off the cylinder from the atmosphere; as the piston is moved towards A the air in AD is compressed and forced through the valve D into the tyre.

We may find the density of the air, after any number of strokes, thus. Let V be the volume of the vessel, v that of the barrel. At each stroke a volume v at atmospheric pressure enters. Thus after n strokes the air in the receiver would, at atmospheric pressure, occupy a volume $V + nv$, and if ρ be the density of air at atmospheric pressure, the mass of air in the vessel is $\rho(V + nv)$. But its actual volume is V and, if ρ_n be its density, its mass is $\rho_n V$.

$$\text{Thus} \quad \rho_n V = \rho(V + nv).$$

$$\text{Hence} \quad \rho_n = \rho \left(1 + n \frac{v}{V} \right).$$

Again, by Boyle's Law the pressure of air is proportional to its density. Thus if p_n be the pressure after n strokes, π the initial pressure,

$$p_n = \pi \left(1 + n \frac{v}{V} \right).$$

Examples. (1) *If the volume of the vessel is ten times that of the barrel, how many strokes are required to double the pressure?*

We are to have $p_n = 2\pi$, also $v/V = 10$.

Thus
$$2 = 1 + \frac{n}{10}$$

or $10 + n = 20, n = 10.$

Hence the pressure is doubled after 10 strokes.

(2) *When the piston of a condenser is pushed as far down as it will go a volume v' is left beneath it. The valves will open when there is a difference of pressure p between the two sides. Shew that the pressure of the air inside the receiver can never be greater than $(\pi - p) v/v' - p$, where π is the atmospheric pressure.*

When the piston is drawn up there is a volume v of air below in the barrel; the pressure of this air is $\pi - p^1$.

As the piston is pushed down this air is compressed; let us suppose that its pressure at its greatest is just insufficient to open the lower valve, then when the stroke is complete its volume is v' ; its pressure therefore is $(\pi - p) v/v'$. Since the valve just does not open the pressure inside is less than this by p . Hence the greatest pressure inside is

$$(\pi - p) \frac{v}{v'} - p.$$

107. The Diving-bell.

This is an apparatus for enabling a man to descend to a considerable depth under water, thus a sunken vessel could be examined, or the foundation of a pier laid or repaired, or work of other kinds carried out.

Take a beaker and immerse it mouth downwards in water: as the beaker is depressed the air it contains is compressed, but the water does not rise so as to fill the beaker completely, there is always air in the upper part of the beaker, a fly or small animal might live there for some time. The beaker is a diving-bell in miniature.

The bell, Fig. 97, consists of a large bell-shaped or cylindrical vessel closed at the top but open underneath. This can be lowered mouth downwards into the water, its weight is greater than the weight of water which would fill it, hence it sinks in the water. As it sinks the air it contains, like that in the beaker, is compressed, and the water rises in the bell but never fills it. The bell is so constructed that a person can stand within it and thus be lowered into the water without depriving him of air to breathe. The bell is usually filled with air by two tubes leading to the atmosphere above. Through

¹ If, as has been assumed in the text above, the valves open with no difference of pressure it would be π ; it is less than this by the pressure required to open the valve.

one of these fresh air is forced into the bell, through the other foul air is withdrawn. The pressure in the bell depends on the depth to which it is sunk. The difficulty of working under very great pressure limits of course the depth at which it can be used.

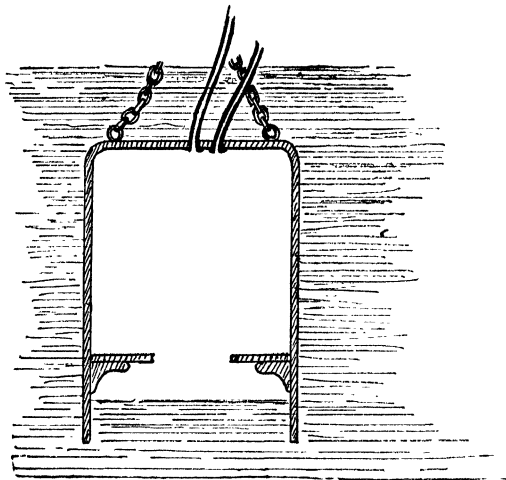

Fig. 97.

The tension on the chain supporting the bell is equal to the difference between the weight of the bell and the weight of water it displaces: as the bell sinks the water rises inside, the weight of water displaced therefore is reduced and the tension increased.

Examples. (1) *A conical wine-glass 4 inches in height is lowered mouth downwards into water until the level of the water inside is 34 feet below the surface; the height of the water-barometer being 34 feet, what is the height of that part of the cone which is occupied by air?*

The pressure in the wine-glass is doubled, thus the volume of air is half what it was.

But the volumes of two cones of the same angle are proportional to the cubes of their heights; hence, if x is the height of the conical volume of air in the bell, we have

$$\frac{x^3}{4^3} = \frac{1}{2}.$$

Therefore
$$z = \frac{4}{\sqrt[3]{2}} = 3.175.$$

Hence the height required is 3.175 inches.

(2) *A cylindrical diving-bell 6 feet in height and 5 feet in diameter is lowered till its top is 45 feet below the surface. What volume of air at atmospheric pressure—that due to 34 feet of water—must be pumped in to fill the bell completely?*

[To solve this it is simplest to suppose the bell to be full and then to find what will be the volume at atmospheric pressure of the air actually in the bell.]

Let V be the volume of the bell.

When the bell is full the level of the water inside is 45 + 6 or 51 feet below the surface. The pressure therefore is that due to a head of (34 + 51) feet of water or $2\frac{1}{2}$ atmospheres. If the air then were at atmospheric pressure its volume would be $\frac{2}{3}$ of V . The volume of air added is at atmospheric pressure $\frac{1}{3}$ of V .

Now
$$V = \frac{\pi}{4} \times 25 \times 6 \text{ c. feet.}$$

Hence the volume required is $9 \times 25 \times \pi/4$ or 177.9 c. feet.

(3) *A piece of wood floats half immersed at the top of the water, how much of it will be immersed when floated in water within the bell mentioned in Example 2?*

Let $2v$ be the volume of the wood in cubic centimetres, σ the density of air at atmospheric pressure referred to water. Let $v+x$ be the volume of the wood in the air in the bell, $v-x$ then will be the volume in the water:

The density of the air in the bell is $\frac{2}{3}\sigma$.

The mass of air displaced in the first case is σv and of water it is v .

Since the wood floats the mass of the wood is equal to the mass of fluid displaced.

Therefore
$$v + \sigma v = \text{mass of wood in grammes.}$$

Under the bell a mass $\frac{2}{3}\sigma(v+x)$ of air is displaced, the mass of water displaced is $v-x$.

Thus
$$v - x + \frac{2}{3}\sigma(v+x) = \text{mass of wood.}$$

Hence, since the mass of the wood is unchanged,

$$v + \sigma v = v - x + \frac{2}{3}\sigma(v+x).$$

Therefore
$$x(1 - \frac{2}{3}\sigma) = \frac{1}{3}\sigma v.$$

Thus
$$x/v = \frac{1}{3}\sigma / (1 - \frac{2}{3}\sigma).$$

The fraction of the whole volume in the air is

$$\frac{1}{2} \left(\frac{v+x}{v} \right) \text{ or } \frac{1}{2} \left(1 + \frac{x}{v} \right).$$

Since σ is approximately .000129 this fraction is approximately $\frac{1}{2}(1.000193)$.

*108. The Volumenometer.

This instrument, as its name indicates, is devised for the measurement of volume and is founded on an application of Boyle's Law. Let the top of the closed tube A in the apparatus shewn in Fig. 77 communicate with a vessel whose volume is to be found. Let V be the volume of this vessel, v the volume of unit length—1 centimetre—of the vertical tube. Let H be the height of the mercury barometer, a_1 the length of the vertical tube AB which is filled with air, h_1 the difference in level between the mercury columns in the two tubes.

The pressure of the air in the closed tube and vessel is measured by a head of mercury of height $H + h_1$, and the volume of the enclosed air is $V + a_1v$.

Now raise the reservoir C ; the mercury rises in AB . Let a_2 be the length of this tube now occupied by air and let h_2 be the difference in level between the two columns.

The air pressure is now measured by a head of mercury $H + h_2$, the volume of air enclosed is $V + a_2v$.

But the mass and temperature of the air enclosed remain unchanged, hence by Boyle's Law the product of the pressure and volume is constant.

Therefore

$$(H + h_1)(V + a_1v) = (H + h_2)(V + a_2v).$$

Whence
$$V(h_1 - h_2) = v\{a_2(H + h_2) - a_1(H + h_1)\},$$

and from this expression V can be found if v is determined by measuring the tube, and a_1 , a_2 , h_1 , h_2 and H are observed.

In this way the volume of a closed vessel which can be connected to the volumenometer is found. To use the instrument to determine the volume of a solid, the solid is placed in the vessel whose volume V has previously been determined and the experiments are repeated in the same manner. Let V' be the volume of the solid and h'_1 , h'_2 , a'_1 , a'_2 the new values of h_1 , etc.

The volume of air in the vessel is now $V - V'$, for a volume V' of the interior is occupied by the solid.

Hence the above equation becomes

$$(V - V')(h'_1 - h'_2) = v\{a'_2(H + h'_2) - a'_1(H + h'_1)\}.$$

From this equation $V - V'$ can be found, but the value of V has already been determined, thus the value of V' is given.

A convenient form for the closed vessel is shown in Fig. 98. It consists of a bulb of known volume V_0 opening into a funnel-shaped space. The upper edges of the funnel are ground flat and the whole can be closed in an air-tight manner by means of a ground glass plate and grease.

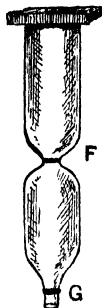

Fig. 98.

Two marks are made on the glass, the one at F between the bulb and the funnel, the other at G below the bulb; the volume of the funnel above F is V , the volume between F and G is V_0 . To use the apparatus the glass plate is removed and the sliding reservoir adjusted so that the mercury fills the bulb and stands at the mark F . On replacing the plate and making the apparatus air-tight we have a volume V of air at atmospheric pressure H .

When the reservoir is lowered the mercury sinks in the bulb. Lower it until the level of the mercury is at G , the mercury in the other tube will be below G , let h be the difference in level. The pressure of the air in the bulb and funnel is now $H - h$, and its volume is $V + V_0$.

$$\text{Thus} \quad (V + V_0) (H - h) = VH,$$

$$\text{and} \quad V = V_0 \frac{H - h}{h}.$$

Now repeat the experiment, placing the body of volume V' in the funnel, let h' be the observed difference of level.

$$\text{Then} \quad V - V' = V_0 \frac{H - h'}{h'}.$$

$$\begin{aligned} \text{Hence} \quad V' &= V_0 \left\{ \frac{H - h}{h} - \frac{H - h'}{h'} \right\} \\ &= V_0 \frac{H(h' - h)}{hh'}. \end{aligned}$$

The method is chiefly useful in determining the volume of a light body of considerable size which cannot be easily weighed in water. By measuring with the balance the mass

of the body and dividing this by the volume the density can be found.

In this way the volume of a piece of pumice-stone, a quantity of glass-wool, or a number of feathers could be found.

EXAMPLES.

HYDROSTATIC MACHINES.

[For a Table of Specific Gravities see p. 15.]

1. The column of water in a siphon contains a small bubble of air, how is the working of the instrument affected?

2. How may a siphon be used to withdraw air from a vessel under water and open below?

3. A small hole is made in one leg of a siphon, how does this affect its working?

4. What height can (1) Mercury, (2) Alcohol be raised by a siphon?

5. A siphon tube leads from the bottom of a vessel, the top of the siphon being below that of the vessel. Water is allowed to drop into the vessel. Explain what happens and shew how this may be applied to explain the action of some forms of intermittent springs.

6. The piston of a common pump is 3 inches in diameter and the spout is 21 feet above the well. What is the force on the piston-rod when the pump is working?

7. In the same pump the length of stroke is 1 foot and the diameter of the pipe leading to the well is 1 inch, how many strokes must be made before the water will flow?

8. If in the same pump the distance from the fulcrum of the pump handle to the piston be 6 inches and from the fulcrum to the point at which the force is applied 4 feet, find the force required to work the pump.

9. What weight of water could be raised per hour by an engine of $\cdot 5$ horse-power working the same pump?

10. A force-pump is employed to raise water a height of 60 feet, what work must be done to deliver 10 cubic feet of water per minute?

11. If the height of the cistern into which water is being pumped be 25 feet and the mechanical advantage of the handle 10, what force is needed to raise water with a pump whose piston is 4 inches in diameter?

The pump is worked at the rate of 10 strokes per minute and the handle moves through 3 feet at each stroke; find the work done and the weight of water raised in an hour.

12. Water is being lifted by a pump to a height of 30 feet, the diameter of the piston is 1 foot and the length of stroke is 3 feet; find the number of strokes per minute if 1500 lbs. are discharged in that time.

13. A force-pump raises water a height of 20 feet and forces it a further height of 60. The diameter of the piston is 6 inches; find the force on the piston rod during the back and forward stroke.

14. The area of the piston of a force-pump is 1 square foot and the length of stroke 5 feet. Find the work done during one down stroke if water is being raised to a height of 50 feet above the pump.

15. How high could a liquid of specific gravity 1.34 be raised by a suction-pump?

16. If the volume of the receiver of an air-pump be three times that of the barrel, calculate in terms of the initial pressure the pressure after 5, 10, and 15 strokes.

17. If with the same pump the gauge originally stood at 30 inches, determine the number of strokes after which it will stand at 25 inches.

18. Find the number of strokes which with the same pump will reduce the pressure to 1 per cent. of its initial value.

19. If the volume of the receiver of a Smeaton's pump be 3 times that of the barrel, at what point of the third stroke will the valve at the top of the barrel open?

20. The range of a Smeaton's pump is 5 inches and the piston at the top and the bottom of its stroke is $\frac{1}{2}$ inch from the ends of the cylinder, determine the minimum density of the air in the receiver neglecting the difference of pressure required to open the valves.

21. Find the ratio of the volume of the receiver to that of the barrel if at the end of the fourth stroke the density of the air is $\frac{2}{3}$ of its original density.

22. Describe some form of air-pump. If the size of the receiver of an air-pump be 1 cubic foot and that of the barrel of the pump 24 cubic inches, how many strokes are required to reduce the pressure of the air to one-tenth of the atmospheric pressure?

23. The volume of the receiver of an air-pump is 4 times that of the barrel. Shew that after 5 strokes the air will be reduced to less than one-third of its initial density.

24. The volume of the receiver of an air-pump is 500 c. cm., and that of the barrel 75 c. cm., find after how many strokes the pressure will be reduced to less than a half of its original value.

25. The barrel of a Smeaton's air-pump is of the same capacity as the receiver and connecting tube. Supposing that the valve at the bottom of the cylinder is the first to cease working, and that there is no leakage, shew that the most complete exhaustion the air-pump can give will be accomplished at the end of 8 strokes. The area of the valve is supposed to be $\frac{1}{100}$ of a square inch, and its weight $\frac{1}{100}$ ths of an ounce, the atmospheric pressure being just under 2112 lbs. weight per square foot.

26. In a Geissler pump the fixed reservoir contains 1000 c. cm. Find the density of the air remaining in a bulb 100 c. cm. in volume after 3 strokes of the pump.

27. Assuming the volume of the tube of a bicycle tyre to be 100 cubic inches and the barrel of a pump used to fill it to be 10 cubic inches, find the number of strokes required to produce double the atmospheric pressure in the tyre.

28. Determine the volume of the barrel of a condenser if one stroke is sufficient to produce a pressure of 5 atmospheres in a tube $\frac{1}{2}$ an inch in diameter and 50 feet long.

29. A speaking tube, of 1 square inch section, is found to be blocked somewhere. A condensing pump, the capacity of whose barrel is 60 cubic inches, is attached to the mouth of the speaking tube, and after 40 strokes the pressure of air in the tube is found to be 3 atmospheres. Shew that the block is 100 feet from the mouth of the tube.

30. A cylindrical diving-bell 9 feet long is sunk in water to such a depth that the water rises $3\frac{1}{2}$ feet in the bell. At what depth is the surface of the water inside the bell if the water barometer stands at 34 feet?

31. A cylindrical bell 10 feet in height is sunk under the sea until the water rises halfway up the bell; find the depth of the top of the bell, taking the height of the water barometer as 33 feet.

32. The same bell is sunk in fresh water and the water rises 2 feet in the bell, find the depth to which it is sunk.

33. What volume of air at atmospheric pressure must be pumped in to fill the bell in each of these two cases?

34. A diving-bell is let down into water so that the level of the water in the bell is 33 feet below the surface of the water. If the bell is cylindrical and no air is pumped into it whilst it goes down, how high will the water have risen in the bell itself?

35. The capacity of a diving-bell is 100 cubic feet. What volume will the air, which fills it at a depth of 60 feet, occupy when raised to the surface, the height of the water barometer being taken as 30 feet?

36. A cylindrical diving-bell is lowered to such a depth that the confined air occupies two-thirds of the interior. Half as much air again is pumped into the bell. How much further may the bell descend before it becomes half full of water?

37. The height of a cylindrical bell is a feet at the surface, a mercury barometer reads h feet, when the bell is sunk it reads h' feet. If ρ be the specific gravity of mercury, find the depth to which the bell has sunk.

38. The diameters of the pistons of a Bramah press are 1 inch and 20 inches respectively, find the weight which can be raised if a force of 2.5 tons weight be applied. At each stroke the small piston moves over 10 inches, find the number of strokes required to raise the weight 25 feet.

39. A lift constructed to carry 10,000 lbs. weight is supplied with water from a height of 150 feet. Find the diameter of the piston.

40. If the sections of the cylinders of a Bramah press be 18 square inches and 1 square foot respectively, what pressure must be applied to the smaller cylinder to produce a pressure of two tons upon the larger?

41. The diameter of the large piston of a press is 10 times that of the small one, and at each stroke the small piston moves through 5 inches. What weight can be raised by a force equal to the weight of 28 lbs. applied to the smaller piston, and how many strokes are required to raise the weight 1 foot?

42. The ram of a press is 20 inches in diameter, and it is required to lift 100 tons, what size should you make the plunger of the pump, if the mechanical advantage of the handle be 10 and the force on the man's hand working the pump 10 lbs. wt.?

43. If the ram of an hydraulic accumulator be 6 inches in diameter, what load is required to produce a pressure of 500 lbs. on the square inch? To what head of water does this correspond?

44. The mechanical advantage of the arm of a safety-valve is 5, and the diameter of the steam valve is 1 inch. If the load at the end of the arms be 30 lbs. weight, find the steam pressure.

45. In a volumenometer the volume of the space into which the body to be measured is put is 100 c.cm., that of the measured space below is 50 c.cm. When a body 25 grammes in mass is inserted and the mercury is brought to the lower mark the pressure is found to be 38 cm.; find the density of the body.

46. In another experiment with the same instrument when the mercury is brought to the lower mark the pressure is 46 cm., find the volume of the body introduced.

47. A horizontal waterpipe is connected with a reservoir; the level of water in the reservoir is 300 feet above the pipe. The pipe whose internal diameter is 1 inch, is cut and stopped by a cork. Find the force exerted by the water on the cork.

48. A safety-valve is kept in position by a horizontal lever 12 inches long having its fulcrum at one end and a weight of 5 lbs. on the other. The valve itself is one square inch in section and its centre is at a distance of one inch from the fulcrum. What is the greatest pressure that the steam in the boiler can have?

49. The safety-valve of a steam-engine is one square inch in section, and its centre is placed 4 inches from the end of a 20 inch lever, from the other end of which a weight of 27 lbs. is suspended. If the atmospheric pressure be 15 lbs. per square inch, find the maximum pressure of the steam in the boiler, when it begins to escape by the valve.

50. The weight of a cubic foot of water being 62 lbs., what volume of water will an engine of 12 horse-power raise by pumping for 1 hour from a well 20 feet deep? If the loss of work from frictional causes be equivalent to 1000 foot lbs. per second, calculate by how much the volume raised will be reduced.

EXAMINATION PAPERS.

I.

1. Distinguish between a solid and a fluid, giving examples and shewing how the substances mentioned conform to the definition.

2. What is meant by viscosity and plasticity? Why is pitch a viscous fluid while wax is a plastic solid? What do you understand by elasticity?

3. Define the pressure at a point in a fluid, and shew that the pressure at any point is the same in all directions. Shew also that in a fluid under gravity the pressure is the same at any two points at the same depth.

4. Shew that if p_1, p_2 be the pressures at two points in a fluid of density ρ and h the vertical distance between the points, $p_2 = p_1 + h\rho g$.

5. Shew that the resultant thrust on an area immersed in a fluid is equal to the weight of a column of fluid whose base is the area, and whose height is the depth of the centre of gravity of the area.

6. Explain how the pressure of the air is measured by the barometer.

7. Explain the action of the siphon.

II.

1. Describe the construction and mode of action of the barometer. When a barometer tube is inclined the top of the column remains at the same vertical height above the mercury in the dish. Why is this? Does the height of the barometer depend on the area of the cross section of the tube?

2. Explain the mode of action of the common pump, the force-pump, and the air-pump.

3. Shew both from theory and experiment that the resultant force on a body immersed in a fluid is equal to the weight of fluid displaced. Deduce hence the laws of floating bodies.

4. Define specific gravity, distinguishing carefully between it and density.

5. Describe the use of the hydrostatic balance, and shew how to employ it to find the specific gravity of a solid lighter than water.

6. Shew how to find the specific gravity of a liquid (*a*) by the use of the specific gravity bottle, (*b*) by the use of Nicholson's hydrometer.

7. A long U-tube contains two liquids which do not mix. Shew how to compare the densities of the two by measuring the heights of the respective columns above the common surface.

ANSWERS TO EXAMPLES.

CHAPTER I. (Page 18.)

- | | |
|--|------------------------------|
| 5. Density, 112 lb. per cubic foot. | Specific Gravity, 1.792. |
| 6. 112.58 grms. | 7. 76.39 lb. per c. ft. |
| 8. 1.1937 grms. per c. cm. | 9. 1.2237 grms. per c. cm. |
| 10. 18.476 grms. per c. cm. | 11. 3437 grains per c. inch. |
| 12. $\frac{\text{Density of sphere}}{\text{Density of cylinder}} = 7.803.$ | 13. 44.68 lb. |
| 14. 199,200 tons. | 15. 53 litres. |
| 17. (i) .975. (ii) 1.027. | 16. 72.4 litres. |
| 19. .00459 sq. cm. | 18. 7.09. |
| 21. $\frac{\text{Weight of glycerine}}{\text{Weight of water}} = .713.$ | 20. 2.82 c. inches. |
| | 22. 2.98 c. cm. |

CHAPTER III. (Page 76.)

1. Pressure in *water* at depth of
 - (1) 25 cm. is 1025 grms.-wt. per sq. cm.
 - (2) 1 metre is 1100 " " "
 - (3) 1 mile is 161,900 " " "
 - (4) 5 kilometres is 501,000 " "
- Pressure in *mercury* at depth of
 - (1) 1 cm. is 1013.6 grms.-wt. per sq. cm.
 - (2) 1 metre is 2360 " " "
 - (3) 25 metres is 35,000 " "
 - (4) 1 kilometre is 1,361,000 "
2. 44.91 ft.
3. 40.66 inches.
4. .795 *p*, 1.28 *p*, *p*, where *p* is the pressure in the water.

CHAPTER V. (Page 114.)

1. 25.9 cubic inches.
2. 87.11 grms.
3. Resultant thrust of water = $41\frac{3}{8}$ kilogrammes-wt. Acceleration = $3106\frac{1}{2}$ cm. per sec. per sec.
4. (1) 100 grms.-wt. (2) 28.66 grms.-wt. (3) 925 grms.-wt.
5. .57 of its volume.
6. Volume of cork = 15.8 times the volume of the iron.
7. 22.44 grms.
8. 6.257 grms.
9. 19,000 c. ft.
10. 65.8 c. inches.
11. 45 c. cm.
12. 0.97:
13. (1) .5454 lb. (2) .3939 lb. (3) .425 lb.
14. 3.07 grms.
15. Wt. of most dense body = 9 times the wt. of least dense body.
16. Mean spec. gravity = 0.9987. Volume = 3875.72 c. inches.
17. .55 of the weight.
18. .537 of the volume of the iron is in mercury, and .463 of the vol. of the iron is in water.
19. Spec. gravity of wood = .533. Spec. gravity of cork = .25. Spec. gravity of ice = .919. Spec. gravity of oak = .75.
20. .726 inches.
21. Volume of iron = 36.4 c. cm. Density of iron = 7.56 grms. per c. cm.
22. .48 cubic inches.
23. .45 inches.
24. Sp. gr. = .5.
25. 2.34 cm. in water. 2.66 cm. in mercury.
27. 93.75 cm.
28. (1) Pressure required = 5 lb.-wt. (2) Wt. of metal = $6\frac{1}{4}$ lb.
30. (1) Floats in ordinary water with .0064 inches above the surface.
(2) " sea-water " .108 " " "
31. 5 lb.-wt.
33. 20 c. cm.
36. 89.8 ft.
37. Mass of iron = 1.66 grms. Mass of wax = 34.34 grms.
38. 0.93.
39. 277.0 c. inches.

CHAPTER VI. (Page 137.)

1. (1) 2.637. (2) 11.37. (3) 2.68. (4) 17.57.
2. (1) .240. (2) .8535. (3) .530. (4) .601.
3. (1) 1.0714. (2) 1.200. (3) 1.276. (4) 1.305.
4. Spec. gravity = 3.57. Volume = 7.69 c. cm.
5. 4.04.
6. 1.069.
7. 43.79 grms.
8. 2.476.
9. (1) 1.064. (2) 0.920. (3) 1.032.
10. 2.077.
11. 2.768.
12. Mass of silver = .997 times the mass of the gold.
13. $1\frac{1}{4}$.
14. .309 of the volume of the mixture is alcohol.

15. 82.9 cm. 16. 6.36 inches. 18. 12.288.
 19. Specific gravity = 3. Volume = 1 c. cm. 20. .923.
 22. 8.88. 23. 1.5. 24. .80.
 25. .787. 26. 13.92 grms. 27. 1.44.
 28. 1.48 c. cm. 30. 2.26.
 31. Mercury falls 1.99 cm. in one leg, and rises 1.99 cm. in the other.
 65.9 cm. of oil are required. 32. 27.2 inches.

CHAPTER VII. (Page 166.)

1. (1) 3800 c. cm. (2) 2992 c. cm. (3) 3839 c. cm. (4) 47.1 c. cm.
 2. 39.1 litres. 3. 18.12 kilogrammes.
 4. 340.5 kilogrammes. 5. 144.16 grms.-wt. per square cm.
 6. Add 13.36 mm. 7. 4.05 mm. 8. 75.394 grms.
 9. Pressure of hydrogen = 14.4 times the pressure of the air.
 10. (1) 749.54 mm. (2) 27.445 inches. (3) 21.176 inches.
 11. (1) 783 c. cm. (2) 306.1 c. cm. (3) 414.7 cubic inches.
 12. 26.48 inches. 13. 2.401 litres.
 14. 24.73 inches of mercury. 15. 8752 yards.
 16. Increases by 10 cubic feet.
 17. 1.782 inches in diameter. 18. .0015 cubic inches.
 19. Diminished to $\frac{1}{3}$ th of its former value. 20. 2.85 cubic ft.
 21. $\frac{1}{3}$ th of the air escapes, or, in other words, the escaped air occupies
 a volume of $85\frac{1}{3}$ cubic inches.
 22. 60 lb.-wt. 23. 8932 yards. 24. .2533 grms.
 27. Weight on mountain = $\frac{1}{3}$ th weight at sea-level.
 29. 30 inches of mercury.
 30. Pressure of the inside air is less than the pressure of the outside
 air by the pressure of the column of water left in the bottle.
 32. 8408 metres. 33. 6181 ft. 35. 30.5 inches.

CHAPTER VIII. (Page 204.)

4. (1) 30 inches. (2) 513.2 inches. 6. 64.4 lb.-wt.
 7. 4 strokes. 8. 8.1 lb.-wt. 9. 47,142 $\frac{1}{2}$ lb.-wt.
 10. 37,500 ft.-lb. per minute.
 11. (1) Force required = 13.635 lb.-wt. (2) Work done = 24,543 ft.-lb.
 (3) Wt. of water raised = 981.72 lb.
 12. 10.2 strokes.

INDEX.

The references are to the pages.

- Air, buoyancy of, 105; corrections for weighing in, 106; pressure of, 142; measure of pressure of, in receiver, 191
- Air-Pump, Hawksbee's, 186; Smeaton's, 187; Tate's, 189; general considerations, 190; Mercury, 193; Sprengel's, 193; Geissler's, 195; Topley's, 196
- Aneroid Barometer, the, 152
- Atmosphere, Height of the Homogeneous, 154
- Average Pressure, 27
- Balance, Hydrostatic, 118; Jolly's, 127
- Balls, Specific Gravity, 128
- Barometer, the, 143; Tube Gauge, 66; Fortin's, 146; forms of, 151; Standard, 151; Aneroid, 152; Water, 153; measurement of heights by, 155
- Barometer reading, corrections to, 148
- Bell, the Diving-, 199
- Bellows, Hydrostatic, 41
- Bottle, Specific Gravity, 128
- Bourdon Gauge, the, 67
- Boyle's Law, 159; deductions from, 162; variations from, 163
- Bramah's Press, 181
- Buoyancy of the air, 105
- Calculation of Thrust, 61
- Centre of Pressure, 83
- Charles and Dalton, law of, 164
- Columns in tubes of unequal area, 136
- Common Hydrometer, the, 122
- Condenser, the, 197
- Corrections to barometer reading, 148
- Curved Surface, thrust on a, 90
- Dalton and Charles, law of, 164
- Deductions, from experiments on fluid pressure, 71; from Boyle's Law, 162
- Density, 7; propositions on, 15
,, Surfaces of equal, 73; of gases, 142
- Dilatation of Gases by heat, 164
- Diving-bell, the, 199
- Double-barrelled pump, 188
- Effective Surface, 53
- Equilibrium, of fluids, 75; stability of, 108
- Experiment, of Otto Guericke, 141; Pascal's, 146
- Experiments, on fluid pressure, 68; deductions from, 71; on floating bodies, 107
- Floating Bodies, 101; experiments on, 107; stability of equilibrium of, 108
- Fluid-Pressure, 46; transmissibility

- of, 37; illustrations of, 43; experiments on, 68
- Fluids, 1, 3; stress in, 22; fundamental property of, 24; pressure within, 30; pressure at a point within, 32; pressure at various points in heavy, 50; equilibrium of, 75
- Fortin's Barometer, 146
- Free Surface of Liquids, 6
- Gases, 4, 5; density of, 142; dilatation by heat, 164; pressure of a mixture of, 164
- Gauge, the Barometer Tube, 66; Bourdon, 67
- Geissler's Air-Pump, 195
- Graphical Solutions, 30
- Gravity, Specific, 8; definitions of, 10; measurement of, 11; values of, 14; propositions on, 15
- Guericke, Otto, experiment of, 141
- Hawksbee's Air-Pump, 186
- Heat, dilatation of gases by, 164
- Height of the Homogeneous Atmosphere, 154
- Heights, measurement of by barometer, 155
- Homogeneous Atmosphere, Height of, 154
- Horizontal Surface, Thrust on a, 79
- Horizontal Thrust, 92
- Hydrometer, the Common, 122; Nicholson's, 125
- Hydrostatic Bellows, 41
,, Balance, 118
- Illustrations of Fluid Pressure, 43
- Jolly's Balance, 127
- Law, Boyle's, 159; deductions from, 162; variations from, 163; of Charles and Dalton, 164
- Level Surfaces, 52
- Liquid, finds its own level, 55
- Liquids, 4; Free Surface of, 6
- Manometers, 62
- Measurement, of Specific Gravity, 11; of heights by barometer, 155; of pressure of air in a receiver, 191
- Mercury Air-Pumps, 193
- Mixture of gases, pressure of, 164
- Nicholson's Hydrometer, 125
- Pascal's experiment, 146
- Pipette, the, 170
- Press, Bramah's, 181; work done in, 182
- Pressure, at a Point, 26; Average, 27; Units of, 28, 58; within a fluid, 30; at a point within a fluid, 32; of the air, 142; in different directions, 33; transmissibility of fluid-, 37; illustrations of fluid-, 43; fluid-, 46; at various points in a heavy fluid, 50; centre of, 83; of a mixture of gases, 164
- Pump, the common, 175; the Lift-, 178; Force-, 179; continuous action, 180; Hawksbee's Air-, 186; Smeaton's Air-, 187; double-barrelled, 188; Tate's Air-, 189; Sprengel's, 193; Geissler's, 195; Topler's, 196
- Resultant vertical thrust, 90—95
,, horizontal ,, 92
- Safety-valve, the, 66
- Shearing Stress, 22
- Siphon, the, 170; experiments with, 172
- Smeaton's Air-Pump, 187
- Solids, 1; stress in, 22; soluble in water, 131
- Solutions, Graphical, 30
- Specific Gravity, 8; definitions of, 10; measurement of, 11; values of, 14; propositions on, 15
- Specific Gravity Balls, 128
,, ,, Bottle, the, 128
- Sprengel's Air Pump, 193

- Stability of equilibrium, 108
 Standard Barometer, 151
 Standard Substance, the, 11
 Stress, general considerations on, 20; Shearing, 22; in solids and fluids, 22; distributed over a surface, 25
 Surfaces of equal density, 73
 Surface, stress distributed over a, 25; Level, 52; Effective, 53; Thrust on a horizontal, 79; on a vertical, 80; on a curved, 90
 Syringe, the, 172
 Tate's Air-Pump, 189
 Tension, 21
 Thrust, 21; examples of uniform and variable, 28; Calculation of, 61; on a horizontal surface, 79; on a vertical surface, 80; on base of a vessel, 86; on a curved surface, 90; resultant vertical, 95
 Topley's Air-Pump, 196
 Transmissibility of Fluid-Pressure, 37
 Tube Gauge, Barometer, 66
 Tubes of unequal area, columns in, 136
 U-Tube Method, the, 133
 Uniform Thrust, examples of, 28
 Units of Pressure, 28, 58
 Values of Specific Gravities, 15
 Valve, the Safety-, 66
 Valves, 174
 Variable Thrust, examples of, 28
 Vertical Surface, Thrust on a, 80
 Vertical Thrust, resultant, 95
 Volumometer, the, 202
 Water Barometer, 153

