

TIGHT BINDING BOOK

UNIVERSAL
LIBRARY

OU_158875

UNIVERSAL
LIBRARY

THE THEORY AND USE

OF A

PHYSICAL BALANCE

BY

JAMES WALKER, M.A.

DEMONSTRATOR AT THE CLARENDON LABORATORY

Oxford

AT THE CLARENDON PRESS

1887

[All rights reserved]

London
HENRY FROWDE



OXFORD UNIVERSITY PRESS WAREHOUSE
AMEN CORNER, E.C.

P R E F A C E.

THIS account of the Physical Balance was intended originally as a chapter of a book on practical physics for the use of students at the Clarendon Laboratory. As it is probable that the publication of the complete course may be delayed, it has been thought advisable to publish the chapters as they are ready, without waiting for the rest of the work.

I find it impossible, owing to the elementary character of the subject, to acknowledge all the sources of information which I have made use of, but may mention especially Jevons' article on the Balance in Watts' Dictionary of Chemistry, and Chisholm's book on Weighing and Measuring in the Nature Series. My thanks are due to Mr. A. L. Selby of Merton College for his kindness in correcting the proofs.

THEORY AND USE OF THE BALANCE.



1.] Measurement of Mass.

Mass is one of the most important quantities which we have to determine, as it is one of the three fundamental units, in terms of which the units of all the quantities which occur in the dynamical sciences may be defined.

The mass of any body is given in terms of some standard unit arbitrarily chosen. The unit employed in physical measurements is called a *gramme*, and is the thousandth part of a certain piece of platinum kept in the Archives at Paris. In making this unit, it was intended that its mass should be that of a cubic centimetre of distilled water at the temperature of 4° C.; later measures however have determined the value (in terms of this arbitrary unit) of a mass of a cubic centimetre of water at the temperature of 4° C. to be 1.000013.

It is an experimental fact that 'the ratio of the accelerations which any two bodies produce in each other by their mutual influence is a constant quantity, quite independent of the exact physical characteristics of that influence': this has led to the definition that the mass of a body is the ratio of the accelerations which the said body and the standard body produce each in the other under any circumstances of mutual influence*.

Whether this statement be accepted as a *definition* of mass or not, it certainly affords the true dynamical *measure* of mass.

Newton discovered as the result of a series of careful experiments that, in the case of two bodies of the same uniform sub-

* Kingdon Clifford, *Common Sense of the Exact Sciences*, p. 269 ; *Elements of Dynamic. Kinematic*, iv. p. 70. This definition is inconsistent with the statement that the units of the quantities which occur in dynamical sciences can be defined in terms of *three* fundamental units.

stance, the masses of the bodies are proportional to their volumes. The name *density* has been given to the ratio which the mass of a body bears to its volume, so that the density of a body is *measured* by the mass of unit volume of the substance of which it is composed. It is clear that, if the kilogramme had been correctly made, distilled water at 4° C. would be a substance whose density is unit density; as it is, however, the density of distilled water at 4° C. is 1.000013.

The only practicable means of determining the mass of a body is that afforded by Newton's discovery, that the weight of a body is proportional to its mass, and consists in comparing its gravity with that of some known mass by means of the balance.

2.] Description of the Balance.

Three forms of balance have been proposed, each consisting in principle of levers of the first kind.

The given body is placed at the end of one arm of the lever, and in the first form its mass is inferred from the known mass which must be placed at a definite point on the other arm in order to cause the lever to assume a given position of equilibrium; in the second form its mass is determined from the point on the second arm at which a given mass is placed, when the lever assumes a given position of equilibrium: in the third form its mass is determined from the position assumed by the lever, when a given mass is placed at a definite point on the second arm.

The first is the form adopted in balances employed for precise measurements, but in the ordinary method of using them they combine all the three forms.

Balances of precision, as made by different makers, differ somewhat in their details, though they agree in their essential points: the following form, made by Oertling and in use in the Clarendon Laboratory, may be taken as illustrative of this class of balance.

The beam (*B*) is cast in brass about .4 cm. thick, and then hard hammered, so as to give it strength and homogeneity. Its length is 40 cm., and its form is that of an acute perforated trapezoid symmetrical about its shorter diagonal, the acute angles

of the trapezoid being cut off and the end of the upper edges rounded. The perforations are made with a view to reduce the mass of the beam without perceptibly decreasing its strength and rigidity.

The column (*C*) of the balance is a brass cylinder, at the top of which is a solid piece of brass, bent so as to enter a perforation of the beam without impeding its motion, and supporting a horizontal plate of hard polished steel or of agate.

The beam rests on this plate by means of a knife-edge (*K*) placed symmetrically with respect to the beam and lying in a plane through the short diagonal of the trapezoid. This knife-edge is either of steel or of agate: in the former case it is the edge of a steel prism whose section is an equilateral triangle*; in the latter case it is made by grinding small rectangular facets on a plate of agate, which is then fixed in a trough cut along the edge of a brass triangular prism. In either case the prism is firmly cemented to a rectangular piece of brass slightly smaller than its base, which fits into a hole in the lower side of a brass bar (*D*) just above the centre of the beam and cast in one piece with it. The knife-edge is accurately adjusted and then fixed by two screws (*S*) passing through the top of the bar.

The axes of suspension for the pans are formed by knife-edges (*k*) similar to the central knife-edge. The brass piece, to which the prism is attached, fits into a rectangular box (*b*) at the end of the beam, and is locked to it by means of two large-headed screws (*s*) passing loosely through the bottom of the box, while it is kept in its place by four screws (*σ*) pressing against it—two through each side of the box. The knife-edges are placed by the maker in one plane, and this arrangement affords the means of slightly adjusting the terminal ones in that plane.

On each of the terminal knife-edges rests a plate of hard polished steel or of agate, embedded in a bar of brass (*p*), to which is attached a rod of brass or of steel (*h*) ending in a circular ring, and bent in such a way that, when the bearing is horizontal, the ring is vertically below the centre of the knife-edge

* In many cases small rectangular facets are ground on the edge of the prism, so as to increase its angle to 120°.

in a plane perpendicular to its length. The pan is suspended from this ring by a hook crossing it at right angles. This hook is 11.5 cm. vertically above the centre of the circular disc which forms the scale pan, to which it is attached by a bent brass wire fixed to opposite ends of one of its diameters.

The position of the beam is indicated by a needle or pointer (π) moving over a graduated ivory scale. This should be in the plane of the beam, and either in a line through the short diagonal (the balance having in this case a double column) or else at one end in the prolongation of the axis, symmetry being restored by a similar pointer at the other end of the beam. The pointer is however often attached to the front of the brass bar which carries the central knife-edge, thus destroying the symmetry in the distribution of the pressure on the knife-edge.

Above the centre of the beam a small mass (g) called the gravity bob, which can be raised or lowered, and a small vane (v) with a motion to the right or left, give a slight control over the position of the centre of mass of the beam; the former gives the means of altering the stability, the latter of adjusting the position of equilibrium of the beam.

The accuracy of a balance largely depending on the sharpness of the knife-edges, it is essential that, except when a weighing is being made, they should not be in contact with their bearings, at the same time it is necessary that the knife-edges and their bearings should have the same relative positions for successive weighings, as on this the invariability of the balance depends. In order to attain these requisites, the balance is provided with an arrangement (A) called the arrestment. This consists of a brass frame, which can be raised or lowered by a cylinder fitting round the column of the balance and resting on an eccentric worked by a milled head. The frame is furnished with two Y's, which catch two brass cylinders (c) fixed just above the central knife-edge and in the highest position of the frame raise the beam, until the knife-edge is no longer in contact with its bearing; at the same time four pins (q), terminating in conical points situated in the same horizontal plane, fit into conical holes in the lower side of the pan suspension planes and raise

them off their knife-edges. On lowering the arrestment the planes are replaced exactly into their former positions on the knife-edges.

As the conical pins move in straight lines, while the holes into which they fit move in circles, it is necessary in order to prevent any displacement to be careful to raise the arrestment so as to arrest the beam in the centre of its swing.

To preserve the balance from currents of air during a weighing, it is enclosed in a case fitted with glass shutters: this is supported on four levelling screws, and has two spirit levels fixed parallel to the sides of the case.

Two rods (r), each ending in a bent arm, pass through the sides of the case and can be moved from the outside by a milled head: these slide on bars (ρ) fixed parallel to the upper edge of the arms of the beam in its arrested position, and serve to place small masses, called riders, on the arms of the balance. A few graduations on the arms indicate the positions of the riders.

The rider is generally made of aluminium wire, and has the mass of a centigramme; it can thus be used instead of putting milligrammes in the pan.

A wooden bridge is also sometimes necessary for placing over the pan without interfering with its motion, when it is required to weigh a body suspended in some liquid.

The boxes of masses supplied with a balance generally contain the following series, making in all 100 grs. :—

<i>Aluminium masses.</i>	<i>Platinum masses.</i>		<i>Brass masses.</i>	
0.001 grs.	0.01 grs.	0.1 grs.	1 gr.	10 grs.
0.001 „	0.01 „	0.1 „	1 „	10 „
0.001 „	0.02 „	0.2 „	2 „	20 „
0.002 „	0.05 „	0.5 „	5 „	50 „
0.005 „				

The masses from 1 gramme upwards are made in the form of a cylinder, slightly hollowed underneath and furnished with a handle at the top for holding them with a pair of forceps. They fit into round holes arranged in two rows at the back of the box.

The smaller masses are in the form of flat squares, with one

corner turned up for holding them by: they fit loosely into square compartments, and are kept covered with a plate of glass.

The box is furnished with two riders and a pair of forceps.

The masses in the boxes in the Clarendon Laboratory have stamped on them their apparent value in air at 10°C . and under a pressure of 76.0 cms. of mercury at 0°C . The value however is liable to alteration from two causes:

- (1) they become lighter by wear;
- (2) they become heavier from dirt and oxidation.

Since the surface and mass vary in different proportions of the linear dimensions, the error is greater in the smaller than in the larger masses.

The brass masses are often gilded or platinised, in order to prevent oxidation: for masses frequently in use this has its disadvantages, as there is then no compensation for the loss of mass by wear.

3.] Mechanical theory of the balance*.

The conditions which an accurate balance must fulfil can only be determined from a consideration of the mechanical theory.

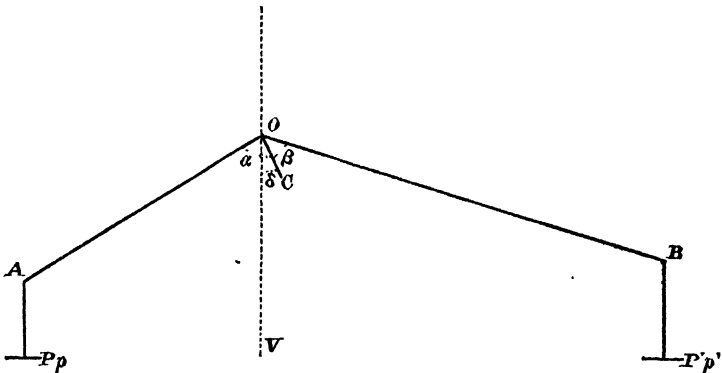

Let OA , OB represent the arms of the balance, O being the

* It is assumed in this section that the three knife-edges are parallel and horizontal; the means of testing for and adjusting this are given in § 5. For a theory which takes into account these errors see an article by Thiessen, *Travaux et Mémoires du Bureau international des Poids et Mesures*, vol. v. 2^m part, p. 1. A theory allowing for variations in the external circumstances of the balance is given by Marek, *ibid.* vol. iii. D. 53.

fulcrum and A, B the axes of suspension of the pans: let C be the position of the centre of mass of the beam.

Call M the mass of the beam,
 P, P' the masses in the pans,
 p, p' the masses of the pans,

and suppose that the centre of mass of each pan and its load remains vertically below its axis of suspension.

If $OA = a, OB = b, OC = c, \angle COA = \alpha, \angle COB = \beta,$

and the position of the beam is given by the angle δ which OC makes with the vertical, then taking moments about O and using for convenience gravitation measure of force,

$$(P + p)a \sin(\alpha - \delta) = (P' + p')b \sin(\beta + \delta) + Mc \sin \delta. \dots (1)$$

Now in an ideal balance we require that, when P, P' are in a given ratio, the beam should take up a definite known position of equilibrium.

Hence, writing $P' = kP$, we must have the equation

$$P\{a \sin(\alpha - \delta) - kb \sin(\beta + \delta)\} + pa \sin(\alpha - \delta) - p'b \sin(\beta + \delta) - Mc \sin \delta = 0 \dots (2)$$

true independently of P ; whence

$$\left. \begin{aligned} a \sin(\alpha - \delta) - kb \sin(\beta + \delta) &= 0 \\ pa \sin(\alpha - \delta) - p'b \sin(\beta + \delta) - Mc \sin \delta &= 0. \end{aligned} \right\} \dots (3)$$

Eliminating δ between these equations, we find as the necessary relation between the constants of the balance

$$(p' - kp)ab \sin(\alpha + \beta) + Mc(a \sin \alpha - kb \sin \beta) = 0. \dots (4)$$

A simple solution of this equation is $\alpha + \beta = 180$ and $a = kb$.

Hence, if the arms of the balance are in the same straight line, whenever the masses in the pans are in the inverse ratio of the lengths of the arms the beam will assume the same position of equilibrium as when the pans are unloaded, whatever the masses of the pans may be.

If the arms of the balance are not in the same straight line, we must take for the fixed position of equilibrium that assumed

by the beam alone without the pans, i. e. take $\delta = 0$, and we must have the ratio of the masses of the pans the inverse of that of the lengths of the horizontal projections of the arms of the balance, and then the masses in the pans, when that position of equilibrium is assumed, will be determined by the same ratio.

It is clearly advantageous that the definite position of equilibrium should correspond to equal masses in the pans: we require then that

- (1) the knife-edges should be in the same plane;
- (2) the distances of the terminal ones from the central one should be equal;
- (3) the pans should have equal mass:—*this* in case condition (1) should not be fulfilled, and because it is advantageous (§ 4) to make observations with the beam horizontal.

4.] Sensibility of the balance.

Returning to equation (1), suppose that the addition of a small mass ϖ to the pan containing the mass P causes an increase in the deflection given by Δ , then

$$(P + p + \varpi) a \sin (a - \delta - \Delta) = (P' + p') b \sin (\beta + \delta + \Delta) + Mc \sin (\delta + \Delta) \dots (5)$$

Developing according to powers of Δ and neglecting small quantities of the second order, we get

$$\{(P + p) a \cos (a - \delta) + (P' + p') b \cos (\beta + \delta) + Mc \cos \delta\} \Delta = (P + p + \varpi) a \sin (a - \delta) - (P' + p') b \sin (\beta + \delta) - Mc \sin \delta.$$

Whence, eliminating $P' + p'$ by means of equation (1),

$$\Delta = \varpi \cdot \frac{a \sin (a - \delta) \sin (\beta + \delta)}{Mc \sin \beta + (P + p) a \sin (a + \beta)} \dots \dots \dots (6)$$

This angle Δ measures the sensibility of the balance corresponding to an overweight ϖ in the left-hand pan: it is only independent of the load if $a + \beta = 180$ or the knife-edges are in one plane.

When this is the case,

$$\Delta = \varpi \cdot \frac{a \sin^2 (\beta + \delta)}{Mc \sin \beta} \dots \dots \dots (7)$$

The maximum value of this expression corresponds to $\beta + 2\delta = 90^\circ$, and thus the sensibility is a maximum, when observations are made with the beam in the position in which the plane through the axis and the centre of mass of the beam makes with the vertical the same angle as does the plane through the axis perpendicular to the arms of the beam.

As there is no practical means of adjusting the balance, so as to satisfy this condition, it is better to adjust the vane until the beam stands horizontal, as the sensibility is greater in this case than if $\alpha = \beta = 90^\circ$.

If the ratio of the masses of the pans is the inverse of that of the lengths of the arms, the position of reference is that of equilibrium of the beam alone and $\delta = 0$, whence

$$\Delta = \varpi \cdot \frac{a \sin \beta}{Mc};$$

which is a maximum if $\beta = 90^\circ$, so that for the maximum sensibility we must again adjust the vane until the beam is horizontal.

Further, the sensibility is increased

- (1) by decreasing the distance between the centre of mass of the beam and the axis of suspension ;
- (2) by decreasing the mass of the beam ;
- (3) by increasing the length of the beam.

As of course any lengthening of the beam must cause an increase in its mass, unless rigidity is sacrificed, a compromise has to be made between the last two desiderata. This has led to the manufacture of two classes of balance, called long-beam and short-beam balances respectively.

With respect to these two forms, it may be stated generally that short-beam balances are advantageous for weighing bodies of small mass and when rapidity of weighing is desired : on the other hand, the unavoidable errors in the setting of the knife-edges become of more importance in short-beam balances, and, the oscillations being necessarily small, minute differences in the masses to be compared are more easily overlooked. The use of a

microscope for reading the deflections of the pointer has to some extent remedied this last defect.

The above investigation has been based on the assumption that no bending of the beam takes place: the effect of such bending is two-fold:—

- (1) the horizontal projections of the arms of the beam are altered in length;
- (2) the sensibility of the balance is lessened in consequence of the lowering of the centre of mass of the beam and the decrease in the angles α, β .

The lowering of the centre of mass of the beam can be remedied by an alteration in the position of the gravity bob; the other changes only slightly affect the sensibility.

5.] Adjustments of the balance.

We have found as the results of the above investigation that the knife-edges must be in one plane and parallel to one another; that the terminal knife-edges must be equidistant from the central one: and that the pans, including their suspension planes, must have equal mass.

We must now consider the method employed by the makers for adjusting the knife-edges and how the accuracy which they attain may be tested. Only slight adjustments are required, as the castings of the beam and its parts can be made with great accuracy.

The central knife-edge is first set at right angles to the plane of the beam by means of a square, and the three knife-edges are then adjusted to be in the same plane by means of a carefully made straight metal bed. The beam is rested on this by its central knife-edge and one of the terminal knife-edges having been brought to the level of the bed by a straight edge placed along it, the other knife-edge is then adjusted till it is in this plane: this is tested by placing a second straight edge across the bed over first one end and then over the other end of the knife-edge. This adjusted knife-edge is then used in the same way for adjusting the first to be in the plane of the bed.

Large adjustments have to be made by packing or filing, but the knife-edge can be slightly raised or lowered by tapping with

a flat hammer the lower or upper part of the vertical side of the beam near the knife-edge.

The arms are then made equal and the knife-edges set parallel by direct measures, the final adjustment for the equality of the arms being made with the balance itself.

It is a most important matter to test whether the adjustments made in this way are free from errors which can be detected by the use of the balance. We first test the parallelism of the knife-edges: an error in this may occur in two ways, either in a horizontal or in a vertical direction, causing respectively a change in the position of equilibrium and in the sensibility when there is a shift of the point, in which the vertical through the centre of mass of the pan and its contents cuts the knife-edge.

To test for the first of these errors, a mass P is suspended from one end of the knife-edge and counterpoised by a mass suspended from the other knife-edge: P is then shifted to the other end of the knife-edge; any change in the position of equilibrium will indicate that that end of the knife-edge at which P appears lightest is nearest the vertical plane through the central knife-edge.

The error in the vertical plane is tested for in a similar manner: the sensibility is determined when the mass P is in the two positions, and that end will be lowest at which the sensibility is least.

The accuracy of the positions of the knife-edges is next tested: to test whether the three knife-edges are in the same plane the sensibility of the balance is determined for different loads; if this remains constant the adjustment is correct. In general, balances are not provided with any simple means of altering this adjustment, but in cases in which such means are provided we may proceed as follows:—

Poise the beam without the pans and note the position of equilibrium: determine the sensibility corresponding to the same position of equilibrium when a mass P is suspended from the knife-edge A : double the masses suspended from the knife-edges, and adjust the gravity bob until the sensibility is the

same as in the former case: move back the bob through double the distance moved, and adjust the knife-edge A , until the same sensibility is obtained. It is assumed of course that the gravity bob moves in a vertical direction.

The correctness of this method may be shown as follows: let the masses suspended from the knife-edge A be P, P' respectively, and in the three cases in which the sensibility is the same let C_1, C_2, C_3 be the distances of the centre of mass of the beam from the axis of suspension; then if Δ is the deflection due to the over-weight ϖ ,

$$\begin{aligned} \frac{\Delta}{\varpi} &= a \frac{\sin a \cdot \sin \beta}{MC_1 \sin \beta + P \sin a + \beta} \\ &= a \frac{\sin a \sin \beta}{MC_2 \sin \beta + P' \sin a + \beta} \\ &= a \frac{\sin a \sin \beta}{MC_3 \sin \beta}. \end{aligned}$$

Hence

$$\frac{C_2 - C_1}{C_1 - C_3} = \frac{P' - P}{P},$$

or if $P' = 2P, \quad C_2 - C_1 = C_1 - C_3.$

The equality of the arms of the balance is shown by there being no change in the position of equilibrium when equal masses are placed in the pans: if they are unequal, one knife-edge must be adjusted till this condition is satisfied.

The pans are shown to be of equal mass, if the position of equilibrium is the same when the pans are in position as when reversed. The difference between their masses may be determined as follows:—when the pans are interchanged determine the mass ϖ_1 , which must be added to the apparently lighter pan in order to bring the beam to its original position of equilibrium; change this mass for a larger one ϖ_2 , and determine the mass ϖ_3 which must be placed in the other pan to restore the original position of equilibrium; then we have the equations

$$\begin{aligned} pa \sin(a - \delta) - p'b \sin(\beta + \delta) &= Mc \sin \delta, \\ (p' + \varpi_1) a \sin(a - \delta) - pb \sin(\beta + \delta) &= Mc \sin \delta, \\ (p' + \varpi_2) a \sin(a - \delta) - (p + \varpi_3) b \sin(\beta + \delta) &= Mc \sin \delta; \end{aligned}$$

whence
$$p - p' = \frac{\omega_1 \cdot \omega_1}{\omega_3 + \omega_2 - \omega_1}.$$

We have seen that it is advantageous to weigh with the beam horizontal as, the knife-edges being in one plane, the sensibility is greatest in that position: it must not however be assumed that the beam is horizontal when the pointer is at the centre of the scale, as both the pointer and the scale may be incorrectly placed. The determination whether any given reading of the pointer corresponds to the horizontal position of the beam may be made as follows:—Adjust the vane until the pointer stands at the given division when the beam *alone* is poised, and determine the deflections δ, δ' when any masses p, p' are suspended from the knife-edges and when these masses are doubled, then δ, δ' being small the beam is horizontal in its initial position if $\delta' = 2\delta$; for we have

$$\tan \delta = \frac{(pa - p'b) \sin a}{Mc + (pa - p'b) \cos a},$$

$$\tan \delta' = \frac{2(pa - p'b) \sin a}{Mc + 2(pa - p'b) \cos a},$$

whence
$$\cot a = (2 \cot \delta' - \cot \delta);$$

hence δ, δ' being small, $a = \pi/2$, or the initial position of the beam is horizontal, if $\delta' = 2\delta$.

The determination of the reading for which this is the case can only be made by successive trials.

6.] Scientific methods of weighing.

The methods given above enable us to test and correct the adjustments of a balance, but though none of the errors should be large, it is scarcely to be hoped that the balance should be perfect in all respects, as each fresh adjustment tends to destroy those already made. It is thus necessary to have a method of weighing which makes us independent of the correctness of the balance.

Two methods have been proposed, called respectively after Gauss and Borda, though the latter method seems really to have been due to Le Père Amiot.

Gauss's method, or the method of double weighing, consists in

placing the body whose mass is required in the right-hand pan and determining the marked masses required in the left-hand pan to bring the beam to the position which it assumes when the pans are unloaded; then repeating the process with the body and marked masses transposed.

Calling X the mass of the body, P, P' the marked masses required to balance it in the two cases, we have

$$\left. \begin{aligned} Xa \sin(a - \delta) &= Pb \sin(\beta + \delta), \\ P'a \sin(a - \delta) &= Xb \sin(\beta + \delta); \end{aligned} \right\}$$

whence

$$X = \sqrt{PP'} = \frac{P + P'}{2}, \text{ if the difference between } P \text{ and } P' \text{ is small.}$$

In Borda's method, or the method of weighing with a tare, a mass greater than that of the body is placed in one pan, and the body whose mass is required in the other together with marked masses sufficient to bring the beam to a convenient position of equilibrium; the body is then removed and the mass P determined which must be substituted for it, in order to bring the beam to the same position of equilibrium: then P is the mass of the body.

In many respects taring is the simpler method of weighing, and it has the advantage that a series of weighings can all be made with the same load in the pans, and hence with a constant sensibility of the balance: Gauss's method is however the more accurate, for in Borda's method the mass of a body is given by the difference of two weighings, and hence the mean error is $m\sqrt{2}$, in Gauss's method the mass is given by the square root of the product of two masses, and each of these masses being given by the difference of two weighings, the mean error of the result is m , $1/m$ being in each case the weight of an observation.

Instead of determining directly by trial the mass required to cause the beam to assume a given position of equilibrium, we may calculate this mass from the positions of equilibrium, situated on different sides of the given position, which correspond to masses in excess and defect of the required mass and differing by some slight amount—in general 1 mg.

Thus suppose that for two masses in the pan differing by 1 mg. the difference between the positions of equilibrium is represented by A scale divisions, while the difference between the required position and that corresponding to the lesser mass is represented by a scale divisions, then since for small deflections the difference in the positions of equilibrium is proportional to the difference in the corresponding masses, the required mass is a/A mg. in excess of the lesser mass.

The position of equilibrium in any case is generally determined by observations of the vibrations of the beam: this method is advantageous, because in many cases friction is sufficiently great to prevent the beam from turning, while if the beam is in motion time would be wasted in waiting for it to come to rest.

The success of the method depends on the assumption that the motion of the beam can be assimilated to that of a pendulum vibrating in a medium whose resistance is proportional to the angular velocity of the pendulum, so that the successive amplitudes on each side of the position of equilibrium form a geometrical progression with the common ratio e^{-r} , where r is a small constant depending on the conditions of the motion.

If this is the case, the reading of the pointer corresponding to the position of equilibrium is easily determined from observations of the oscillations; for if $a_1, b_1, a_2, b_2 \dots$ are the readings corresponding to the successive turning-points of the pointer, x the reading corresponding to the position of equilibrium, and a the amplitude of the first swing, then

$$\begin{array}{ll} a_1 = x \pm a, & b_1 = x \mp a e^{-r}, \\ a_2 = x \pm a e^{-2r}, & b_2 = x \mp a e^{-3r}, \\ a_3 = x \pm a e^{-4r}, & b_3 = x \mp a e^{-5r}, \\ \dots & \dots \end{array}$$

whence, observing an *odd* number of vibrations and neglecting the square of the small quantity r , we have

$$2x = \frac{\Sigma a}{n+1} + \frac{\Sigma b}{n}.$$

In order to see whether the fundamental assumption is legiti-

mate, it is better, instead of calculating the position of equilibrium from the above formula, to determine it as half the mean of the quantities

$$\frac{a_1 + a_2}{2} + b_1, \quad \frac{b_1 + b_2}{2} + a_2, \quad \frac{a_2 + a_3}{2} + b_2 \dots,$$

as the constancy of these quantities will indicate the regularity of the decrease of the extent of the vibrations.

7.] Equations of motion of the balance.

The conditions under which the use of the method of vibrations is permissible can only be determined from a consideration of the equations of motion of the balance.

Suppose that at any time t the beam has rotated through an angle θ from its position of equilibrium, and that the planes through the terminal knife-edges (which we shall suppose parallel to the central knife-edge) and the centres of mass of the pans and their contents make angles ϕ, ψ with the vertical; then if a_1, b_1 are the distances of these centres of mass from the knife-edges, the velocity of the one will be the resultant of the velocities $a\theta'$ and $a_1\phi'$ in directions inclined to one another at an angle $a - \delta - \theta + \phi$, so that the square of its velocity will be

$$a^2\theta'^2 + 2aa_1 \cos(a - \delta - \theta + \phi) \theta' \phi' + a_1^2 \phi'^2.$$

The square of the velocity of the other centre of mass will be

$$b^2\theta'^2 + 2bb_1 \cos(\beta + \delta + \theta - \psi) \theta' \psi' + b_1^2 \psi'^2;$$

hence, if K is the radius of gyration of the beam about its axis of suspension and k, l the radii of gyration of the pans and their contents about their axes of suspension, the kinetic energy T of the system is given by

$$\begin{aligned} 2T &= MK^2\theta'^2 + p\{a^2\theta'^2 + 2aa_1 \cos(a - \delta - \theta + \phi) \theta' \phi' + k^2\phi'^2\} \\ &\quad + p'\{b^2\theta'^2 + 2bb_1 \cos(\beta + \delta + \theta - \psi) \theta' \psi' + l^2\psi'^2\}, \\ &= (MK^2 + pa^2 + p'k^2) \theta'^2 + 2paa_1 \cos(a - \delta) \theta' \phi' + pk^2\phi'^2 \\ &\quad + 2p'bb_1 \cos(\beta + \delta) \theta' \psi' + p'l^2\psi'^2, \end{aligned}$$

if the oscillations are small.

The potential energy of the system is

$$gMc \{ \cos \delta - \cos(\theta + \delta) \} + gp \{ a (\cos \overline{a - \delta} - \cos \overline{a - \delta - \theta}) + a_1(1 - \cos \phi) \} \\ + gp' \{ b (\cos \overline{\beta + \delta} - \cos \overline{\beta + \delta + \theta}) + b_1(1 - \cos \psi) \} \\ = \frac{g}{2} [Mc\theta^2 + p \{ a \cos(a - \delta)\theta^2 + a_1\phi^2 \} + p' \{ b \cos(\beta + \delta)\theta^2 + b_1\psi^2 \}],$$

since $pa \sin(a - \delta) = p'b \sin(\beta + \delta) + Mc \sin \delta$.

Thus the equations of motion are

$$(MK^2 + pa^2 + p'b^2) \theta'' + paa_1 \cos(a - \delta) \phi'' + p'bb_1 \cos(\beta + \delta) \psi'' \\ = -g \{ Mc + pa \cos(a - \delta) + p'b \cos(\beta + \delta) \} \theta, \\ aa_1 \cos(a - \delta) \theta'' + k^2 \phi'' = -ga_1 \phi, \\ bb_1 \cos(\beta + \delta) \theta'' + l^2 \psi'' = -gb_1 \psi;$$

whence

$$\theta = L_1 I_{11} (q_1^2) \sin(q_1 t + a_1) + L_2 I_{11} (q_2^2) \sin(q_2 t + a_2) \\ + L_3 I_{11} (q_3^2) \sin(q_3 t + a_3), \\ \phi = L_1 I_{12} (q_1^2) \sin(q_1 t + a_1) + L_2 I_{12} (q_2^2) \sin(q_2 t + a_2) \\ + L_3 I_{12} (q_3^2) \sin(q_3 t + a_3), \\ \psi = L_1 I_{13} (q_1^2) \sin(q_1 t + a_1) + L_2 I_{13} (q_2^2) \sin(q_2 t + a_2) \\ + L_3 I_{13} (q_3^2) \sin(q_3 t + a_3),$$

where

$$\left. \begin{array}{l} L_1, L_2, L_3 \\ a_1, a_2, a_3 \end{array} \right\} \text{ are determined from the initial conditions, and}$$

q_1, q_2, q_3 are the roots, I_{11}, I_{12}, I_{13} the minors of the determinant

$$\left| \begin{array}{ccc} Aq^2 - gC, & paa_1 \cos(a - \delta) q^2, & p'bb_1 \cos(\beta + \delta) q^2, \\ aa_1 \cos(a - \delta) q^2, & k^2 q^2 - ga_1, & 0, \\ bb_1 \cos(\beta + \delta) q^2, & 0, & l^2 q^2 - gb_1, \end{array} \right| = 0,$$

where $A = MK^2 + pa^2 + p'b^2$, $C = Mc + pa \cos(a - \delta) + p'b \cos(\beta + \delta)$.

If the friction and the resistance of the air introduce into the equations terms varying as the angular velocity, the terms in the expressions for θ, ϕ, ψ will be multiplied by factors of the form e^{-rt} , while the values of q_1, q_2, q_3 will remain practically unaltered*.

Now in order that the method of vibrations may be employed,

* Cf. Routh, Advanced Rigid Dynamics, § 321.

it is necessary that the beam should have a simple definite period of vibration: this can only happen in two cases; *firstly* if the centre of mass of each pan remains vertically below its axis of suspension, *secondly* if the system describes a principal oscillation.

Now the above investigation shows that the first of these conditions can never be fulfilled, while the second requires that the initial displacements and velocities of the beam and the pans should have the ratios of the minors of any row of the determinantal equation *—a condition which it is scarcely possible to satisfy.

The motion of the beam, however, is a vibration about a mean position which is continually shifting according to a law depending upon the constants of the balance, the masses in the pans, and the initial conditions; and the position determined by the method given in the last section will differ from the true position of equilibrium by an amount depending on these quantities: since then in a series of weighings the masses in the pans remain practically constant, the method of vibrations may be employed provided we always observe the same number of vibrations, and arrange matters so that the initial conditions also remain practically the same in the whole series of determinations.

The best means of starting the beam, so as to effect this, is to rest the rider which is not in use on the beam with the wire of its supporting arm through its eye; then on releasing the beam the weight of the rider will start a vibration, and as the beam swings away, the rider may be removed out of reach of the beam. A vibration with any required initial amplitude can thus be started without the risk of setting up an independent vibration of the pans.

8.] Correction of weighings for the buoyancy of the air.

Since by Archimedes' principle every body experiences an apparent loss of mass equal to that of an equal volume of the fluid in which it is placed, the results obtained by the above methods of weighing give only the equality between the *apparent* mass of the body and of the marked masses, except when the weighings

* Routh, Advanced Rigid Dynamics, § 54.

are made in vacuo, or when the given body and the marked masses have the same density.

Suppose the weighings to be made in air. If Q is the true mass of the body, d its density at 0°C ., β the coefficient of cubical expansion of its substance, then its volume at 0°C . is Q/d , and at $t^\circ\text{C}$. is $Q(1 + \beta t)/d$: hence if a' is the mass of 1 cc. of air at the time of weighing, the mass of air displaced is $a'Q(1 + \beta t)/d$, and the apparent mass of the body is

$$Q' = Q \left\{ 1 - \frac{a'}{d} (1 + \beta t) \right\}.$$

The value of a' is dependent on the pressure, the temperature, and the hygrometric state of the atmosphere.

Since Boyle's law is true for small variations of pressure, we have, if h' is the pressure expressed in centimetres of mercury at 0°C ., t is the temperature, and a the mass of unit volume of air at standard pressure and temperature,

$$a' = a \frac{h'}{76} \times \frac{1}{1 + at},$$

where $a = 0.00367$, the coefficient of expansion of air.

Suppose the air contains aqueous vapour, whose tension expressed in cm. of mercury at 0°C . is e ; then the pressure h given by the barometer is made up of the pressure h' of the dry air and the pressure e of the aqueous vapour. Hence $h' = h - e$, and the density of the dry air is

$$a' = a \cdot \frac{h - e}{76} \cdot \frac{1}{1 + at},$$

the density of the aqueous vapour is

$$b' = 0.622 a \cdot \frac{e}{76} \cdot \frac{1}{1 + at},$$

since Charles's law is approximately true, and since from Regnault's experiments the density of aqueous vapour at standard pressure and temperature is 0.622, relatively to dry air at the same pressure and temperature. Thus the density of the mixture is

$$a \cdot \frac{h - 0.378e}{76} \cdot \frac{1}{1 + at},$$

and the apparent mass of the body is

$$Q' = Q \left\{ 1 - \frac{a}{d} \cdot \frac{h - 0.378e}{76} \cdot \frac{1 + \beta t}{1 + \alpha t} \right\},$$

a being the density of dry air at standard pressure and temperature at the place of weighing.

A similar correction has to be made for the marked masses; this however may in general be neglected when they are marked with their apparent value in air at 10° C. and pressure of 76.0 cm. of mercury.

The mass of a cubic centimetre of air has been determined with great accuracy by Regnault: the value deduced from his observations is that, at the sea-level and latitude 45° , the mass of a cubic centimetre of dry air containing an average amount of carbonic acid is 0.00129307 grms. at standard pressure and temperature; hence at a height H above the sea-level and latitude λ it will be

$$0.00129307 \{ 1 - 1.96H \times 10^{-7} \} \{ 1 - 0.00259 \cos 2\lambda \}^*,$$

At Oxford (latitude $51^{\circ} 45' 36''$ and height above the sea-level 64 metres) the value of a may be taken to be 0.00129384.

The value of e has strictly to be determined by hygrometric measurements; it may however generally be taken as two-thirds of the maximum pressure corresponding to the temperature at the time.

9.] Use of the balance.

The details of the methods of using the balance are given above, but it may be advantageous to sum up the precautions that must be taken †.

- (1) See that the pans are carefully dusted, the rider in its place, and that nothing is likely to interfere with the swing of the beam.
- (2) In releasing and arresting the beam be careful to avoid all jerks, and always arrest the beam as it passes through its position of equilibrium.

* Cf. Travaux et Mémoires du Bureau international des Poids et Mesures, vol. p. A. 9.

† I am indebted to Stewart and Gee's Practical Physics for the idea of collecting together the precautions to be taken in using a balance.

- (3) Always arrest the beam before changing the masses in the pan.
- (4) In using the method of vibrations be careful to avoid all independent swings of the pans.
- (5) If there is any difficulty in starting the beam, rest the rider which is not in use on the beam with the wire of its supporting arm through its eye; then on releasing the beam the weight of the rider will start a vibration, and as the beam swings away, the rider may be removed out of reach of the beam.
- (6) It is as well to try the marked masses methodically in their proper order, and to arrange them in order of magnitude on the pan.
- (7) Never touch the pans or marked masses with the finger or with anything likely to injure them.
- (8) Liquids must be weighed in stoppered bottles.
- (9) Avoid all currents of air in the balance case, and make the final weighings with the case closed.
- (10) See that everything is put away and the beam arrested when the weighings are finished.

10.] Determination of Density.

Density has been defined as the ratio which the mass of a body bears to its volume, and is hence measured by the mass contained in unit volume of the body.

Since the volume changes with the temperature, it is necessary in speaking of the density to name the temperature at which it is taken: it is convenient as a rule to determine the density which a body has at the temperature 0°C .

Relative density is the ratio of the mass of any volume of the substance to that of an equal volume of some given substance: the standard substance is generally distilled water at 4°C . for solids and liquids, and for gases and vapours air under the same conditions of pressure and temperature.

The method employed in finding the density of any body consists in finding its density *relatively* to some substance whose density is known (where possible, water), and multiplying the density thus obtained by that of the substance used for com-

parison. The *absolute* density of water at different temperatures is thus a most important quantity, and it has been determined by careful observations of the dilatation of water combined with that of the absolute density at 0° C.

The method of determining this has consisted in finding the apparent loss of mass which a body of known dimensions experiences when plunged into water. A carefully turned cylinder on a circular base has been the form of body generally employed, as it can be made with the greatest accuracy and its volume can be readily calculated from a measurement of its dimensions.

The cylinder is suspended from one pan of the balance by a fine thread and a counterpoise is placed in the other pan to bring the beam to a convenient position of equilibrium: it is then plunged in distilled water from which the air has been removed by boiling or by the air-pump; the water is surrounded by melting ice, so that it may be of uniform temperature; and a determination is made of the masses which must be placed in the pan in order to bring the beam back to its former position of equilibrium.

Then, if the temperature and the pressure have remained the same during the two operations,

$$\begin{aligned} P \text{ (the mass added)} &= \text{the difference of the masses of air and} \\ &\quad \text{water displaced by the cylinder,} \\ &= V_0 \{ \Delta_0 - a_t (1 + \mu t) \}, \end{aligned}$$

where μ is the coefficient of expansion of the cylinder,

t the temperature at the time of counterpoising,

a_t the density of air at the time of counterpoising;

$$\therefore \Delta_0 = \frac{P}{V_0 \left\{ 1 - \frac{a_t}{\Delta_0} (1 + \mu t) \right\}} = \frac{P_0 \left\{ 1 - \frac{a_t}{\delta} \right\}}{V_0 \left\{ 1 - \frac{a_t}{\Delta_0} (1 + \mu t) \right\}}$$

if the masses are marked with their true mass P_0 , and δ is their density.

$$\text{Now } \frac{a_t}{\delta} = \frac{a_t}{\Delta_4} \times \frac{\Delta_4}{\delta} = \text{ratio of the relative densities of air and} \\ \text{of the material of the marked masses at } t^{\circ} \text{ C.}$$

$\frac{a_t}{\Delta_0}$ = the ratio of the relative density of air at t° C. to that of water at 0° C., and these quantities may be determined by the balance.

If the temperature and pressure change between the two operations, the complete formula is

$$\Delta_0 = \frac{P_0 \left(1 - \frac{a_1}{d_1}\right) \left(1 - \frac{a_2}{\delta}\right)}{V_0 \left[\left(1 - \frac{a_1}{d_1}\right) + \frac{C_0}{\Delta_0} \left(\frac{a_1}{d_1} - \frac{a_2}{d_2}\right) - \frac{a_1}{\Delta_0} (1 + \mu t_1) \left(1 - \frac{a_2}{d_2}\right) \right]},$$

where the suffixes (1) (2) refer to the first and second operations respectively, and d_1, d_2 are the densities of the counterpoise at the two temperatures, C_0 the density of the cylinder at 0° C.

Recent experiments have given for Δ_0 the value 0.999884, and the value calculated by Rosetti from the best observations of the expansion of water gives

$$\frac{V_0}{V_4} = 1.000129;$$

hence $\Delta_4 = 0.999884 \times 1.000129 = 1.000013^*$.

* Cf. Pellat, Cours de Phys., livre ii. chap. i. § 17.

DETERMINATION OF DENSITY.

I. The density of a body heavier than water and not acted on by it.

Apparatus. Balance. Marked masses. Bridge.
Hair for suspending the body.
Beaker. Distilled water. Thermometer.

Method. Place in the left-hand pan of the balance a counterpoise of mass ϖ greater than that of the body*.

- (1) Suspend the body from the hook above the right-hand pan, and determine the mass W_1 required to bring the beam to a convenient position of equilibrium.
- (2) Determine the mass W_2 , which can be substituted for the contents of the right-hand pan without disturbing the equilibrium.
- (3) Suspend the body from the hook, so that it hangs in a beaker of cold distilled water* (the air having previously been removed by boiling or by the air-pump), and determine the mass W_3 required to bring the beam to its original position of equilibrium.

Calculation. Suppose the temperature of the air and water to be t° during the operations.

Let a_t , Δ_t be the density of the air and water during the weighings ;

V_t , S_t the volume and density of the body ;

then, m being a factor depending on the constants of the balance, we get $m\varpi = V_t(S_t - a_t) + W_1 = W_2 = V_t(S_t - \Delta_t) + W_3$,

$$\text{whence} \quad S_t - a_t = \frac{W_2 - W_1}{W_3 - W_1} (\Delta_t - a_t).$$

If κ is the coefficient of cubical expansion of the body, the density at 0°C. is $S_t(1 + \kappa t)$.

If the temperature of the water is t'° , that of the air being t° , then $m\varpi = V_0(S_0 - \kappa a_t) + W_1 = W_2 = V_0(S_0 - \kappa' \Delta_t) + W_3$,

$$\text{where} \quad k = 1 + \kappa t, \quad k' = 1 + \kappa' t,$$

$$\text{whence} \quad S_0 - \kappa a_t = \frac{W_2 - W_1}{W_3 - W_1} (k' \Delta_t - \kappa a_t).$$

* In this and the succeeding methods the counterpoise is supposed unchanged during the successive operations, the right-hand pan emptied between each.

II. Density of a body lighter than water and not acted on by it.

Apparatus. Balance. Marked masses. Bridge.
Hair. Sinker (cage of platinum wire).
Beaker. Distilled water. Thermometer.

Method. Place in the left-hand pan of the balance a counterpoise of mass ϖ greater than that of the body and sinker.

- (1) Suspend the body and sinker from the hook above the right-hand pan, and determine the mass W_1 required to bring the beam to a convenient position of equilibrium.
- (2) Suspend the sinker *alone* from the hook and determine the mass W_2 required to bring the beam to its original position of equilibrium.
- (3) Suspend the sinker and body from the hook, so that they hang in a beaker of cold distilled water (the air adhering to them having been previously removed*), and determine the mass W_3 required to bring the beam to its original position of equilibrium.
- (4) Suspend the sinker *alone* from the hook, so that it hangs in the beaker of water, and determine the mass W_4 required to bring the beam to its original position of equilibrium.

Calculation. Suppose the temperature of the air and water to be t° during the operations.

Let a_t, Δ_t be the densities of air and water during the operations;

V_t, S_t the volume and density of the body;

K, K' the apparent mass of the sinker in air and in water.

The successive operations give

$$\begin{aligned} m\varpi &= K + V_t(S_t - a_t) + W_1 = K + W_2 \\ &= K' + V_t(S_t - \Delta_t) + W_3 = K' + W_4. \end{aligned}$$

Hence
$$S_t - a_t = \frac{W_2 - W_1}{W_2 - W_1 + W_3 - W_4} \cdot (\Delta_t - a_t).$$

* In the case of bodies of low melting point, the air must be removed by placing the beaker of water under the receiver of an air-pump. The use of recently boiled water greatly facilitates the process

III. Density of a liquid by the hydrostatic method.

Apparatus. Balance. Marked Masses. Bridge.

Hair. Glass sinker.

Beaker. Distilled water. Thermometer.

Method. Place in the left-hand pan a counterpoise of mass w greater than that of the sinker.

- (1) Suspend the sinker from the hook above the right-hand pan, and determine the mass W_1 required to bring the beam to a convenient position of equilibrium.
- (2) Suspend the sinker from the hook so that it hangs in a beaker containing the given liquid, and determine the mass W_2 required to bring the beam to its original position of equilibrium.
- (3) Wash the sinker, and suspend it from the hook so that it hangs in a beaker of cold distilled water, and determine the mass W_3 required to bring the beam to its original position of equilibrium.

Calculation. Suppose the temperature of the air, water, and liquid to be t° during the operations.

Let a_t , Δ_t be the densities of air and water during the operations ;

M the true mass of the sinker ;

V_t the volume of the sinker ;

S_t the density of the liquid.

The successive operations give

$$mw = M - V_t a_t + W_1 = M - V_t S_t + W_2 = M - V_t \Delta_t + W_3,$$

whence we get

$$S_t - a_t = \frac{W_2 - W_1}{W_3 - W_1} \cdot (\Delta_t - a_t).$$

IV. Density of a liquid by means of a 'specific gravity' bottle.

Apparatus. Balance. Marked masses.
 Distilled water. Thermometer.
 Specific gravity bottle. Glass funnel.
 Blotting paper. Two pipettes.
 Solution of caustic soda. Sulphuric acid. Alcohol.
 Ether.

Method. Clean and dry the bottle. This is done as follows :
 rinse out the bottle with (1) the solution of caustic soda, (2)
 sulphuric acid, (3) distilled water, (4) alcohol, (5) ether ; then
 draw a current of air through by means of the air-pump.

Place in the left-hand pan of the balance a counterpoise of
 mass ω , greater than that of the bottle and the greatest mass
 to be subsequently used in it.

- (1) In the right-hand pan place the empty bottle, and
 determine the mass W_1 required to bring the beam
 to a convenient position of equilibrium.
- (2) Fill the bottle with the liquid*, until the plane through
 the mark on the neck just touches the bottom of
 the meniscus, removing any drops adhering to the
 neck with a piece of blotting paper. Replace the
 bottle on the pan, and determine the mass W_2 re-
 quired to bring the beam to its original position of
 equilibrium.
- (3) Wash the bottle and fill it up to the mark with distilled
 water : replace it on the pan, and determine the
 mass W_3 required to bring the beam to its original
 position of equilibrium.

Calculation. Let t be the temperature of the air, liquid, and
 water during the operations ;
 S_t, Δ_t, a_t the densities of the liquid, the water,
 and the air during the operations ;
 B the apparent mass of the bottle in air ;
 V_t the volume occupied by the liquids.

The successive operations give

$$m\omega = B + W_1 = B + V_t(S_t - a_t) + W_2 = B + V_t(\Delta_t - a_t) + W_3,$$

$$\text{whence} \quad S_t - a_t = \frac{W_1 - W_2}{W_1 - W_3} (\Delta_t - a_t).$$

* In the case of liquids with a large co-efficient of expansion, the adjustment
 of the level of the liquid must be made in a water bath of constant temperature.

V. Density of a solid in small pieces, and not acted on by water.

Apparatus. Balance. Marked masses.

Distilled water. Thermometer. Watch-glass.

Specific gravity bottle, &c.

Method. Clean and fill the bottle with distilled water which has been recently boiled.

Place in the left-hand pan of the balance a counterpoise of mass ω greater than that of the bottle of water, the watch-glass and the pieces of solid.

(1) Place the watch-glass containing the solid, and the bottle of water in the right-hand pan, and determine the mass W_1 required to bring the beam to a convenient position of equilibrium.

(2) Place the bottle of water and the watch-glass *without* the solid in the right-hand pan, and determine the mass W_2 required to bring the beam to its original position of equilibrium.

During this operation boil the pieces of solid in a beaker of water, so as to thoroughly wet them.

(3) Transfer the pieces of solid to the bottle, and bring the level of the water down to the mark. Place the bottle and watch-glass in the right-hand pan, and determine the mass W_3 required to bring the beam to its original position of equilibrium.

Calculation. Let t be the temperature during the operations ;

a_t, Δ_t the densities of the air and water ;

V_s, S_t the volume and density of the solid.

Then the above operations give us

$$V_t(S_t - a_t) = W_2 - W_1,$$

$$V_t(\Delta_t - a_t) = W_3 - W_1,$$

whence
$$S_t - a_t = \frac{W_2 - W_1}{W_3 - W_1} \cdot (\Delta_t - a_t).$$

VI. Density of a solid in small pieces and acted on by air and water.

Apparatus. Balance. Marked masses.

Distilled water. Thermometer.

Liquid without action on the substance (e. g. Benzoline).

Specific gravity bottle, &c.

Method. Clean and dry the bottle.

Place in the left-hand pan a counterpoise of mass ϖ greater than that of the bottle and the greatest mass to be subsequently used in it.

- (1) Place the bottle in the right-hand pan, and determine the mass W_1 required to bring the beam to a convenient position of equilibrium.
- (2) Fill the bottle up to the mark with the liquid; replace it on the pan, and determine the mass W_2 required to bring the beam to its original position of equilibrium.
- (3) Place the solid in the bottle *without removing any of the liquid*: replace the bottle on the pan, and determine the mass W_3 required to bring the beam to its original position of equilibrium.
- (4) Adjust the level of the liquid to the mark; replace the bottle on the pan, and determine the mass W_4 required to bring the beam to its original position of equilibrium.
- (5) Clean the bottle and fill it up to the mark with distilled water: replace it on the pan, and determine the mass W_5 required to bring the beam to its original position of equilibrium.

Calculation. Let a_i, Δ_i be the densities of air and water during the operations;

V_s, S_s the volume and density of the solid;

S_l the density of the liquid;

B the apparent mass of the bottle in air;

V' its internal volume up to the mark.

The successive operations give

$$m\varpi = B + W_1, \quad \dots \dots \dots (1)$$

$$m\varpi = B + V'_t(S'_t - a_t) + W_2, \quad \dots \dots \dots (2)$$

$$m\varpi = B + V'_t(S'_t - a_t) + V_t(S_t - a_t) + W_3, \quad \dots \dots \dots (3)$$

$$m\varpi = B + (V'_t - V_t)(S'_t - a_t) + V_t(S_t - a_t) + W_4, \quad \dots \dots (4)$$

$$m\varpi = B + V'_t(\Delta_t - a_t) + W_5. \quad \dots \dots \dots (5)$$

From equations (1), (2), (5) we get

$$S'_t - a_t = \frac{W_1 - W_2}{W_1 - W_5}(\Delta_t - a_t).$$

From equations (2), (3), (4)

$$S_t - a_t = \frac{W_2 - W_3}{W_4 - W_3}(S'_t - a_t).$$

VII. Determination of the contraction which takes place when known masses of water and alcohol are mixed together.

Apparatus. Balance. Marked masses.
 Stoppered flask. Graduated pipettes.
 Distilled water. Thermometer.
 Specific gravity bottle, &c.

Method. A. Make a solution containing known masses of water and alcohol as follows :—

Place in the left-hand pan a counterpoise of mass ϖ greater than that of the flask and the mixture to be used.

- (1) Place the flask in the right-hand pan, and determine the mass W_1 required to bring the beam to a convenient position of equilibrium.
- (2) Put into the flask by means of the pipette an approximately known quantity of water: replace the flask on the pan, and determine the mass W_2 required to bring the beam to its original position of equilibrium.
- (3) Pour on the top of the water an approximately known mass of alcohol: replace the flask on the pan, and determine the mass W_3 required to bring the beam to its original position of equilibrium.
- (4) Let the liquids mix together, and place the flask in a water-bath to cool.

B. Determine the density of the alcohol used, paying special attention to temperature.

C. Determine the density of the solution *A*.

Calculation. A. Let t be the temperature of the water and alcohol ;

V, V' the volumes, Δ_t, σ_t the densities of the water and alcohol ;

B the apparent mass of the flask in air ;

a_t the density of the air during the operations.

The successive operations give

$$m\varpi = B + W_1,$$

$$m\varpi = B + V(\Delta_t - a_t) + W_2,$$

$$m\varpi = B + V(\Delta_t - a_t) + V'(\sigma_t - a_t) + W_3;$$

then the true masses of the alcohol used and of the water are

$$\mu = (W_2 - W_3) \cdot \frac{\sigma_t}{\sigma_t - \alpha_t}, \quad \nu = (W_1 - W_2) \cdot \frac{\Delta_t}{\Delta_t - \alpha_t}.$$

B. By means of the table (page 39) determine the strength of the alcohol used, and hence find the true masses M , N of absolute alcohol and of water in the solution A .

C. Let S_t be the density at t° of the solution containing M parts by mass of absolute alcohol and N parts by mass of water, and

Σ_t the density of absolute alcohol at t° .

The volume before mixing is $M/\Sigma_t + N/\Delta_t$,

the volume after mixing is $(M + N)/S_t$.

Hence the contraction is

$$\frac{M}{\Sigma_t} + \frac{N}{\Delta_t} - \frac{M + N}{S_t}.$$

If C is the contraction referred to 100 volumes of the resulting fluid,

$$C : \frac{M}{\Sigma_t} + \frac{N}{\Delta_t} - \frac{M + N}{S_t} :: 100 : \frac{M + N}{S_t};$$

whence, if $M + N = 100$,

$$C = S_t \left(\frac{1}{\Sigma_t} - \frac{1}{\Delta_t} \right) M + S_t \frac{100}{\Delta_t} - 100.$$

TABLES.

I. Density of Water.

The volume and relative density at different temperatures from Rosetti's results deduced from the best experiments. Cf. Atti dell' Instituto Veneto, xii, xiii; Pogg. Ann., Ergänzb. v. 258; Ann. de Ch. et de Phys. (4). x. 461; xvii. 370.

Absolute density deduced from Miller's reduction of Kupffer's experiments.

<i>t.</i>	Volume.	Relative Density.	Absolute Density.
0°	1.000129	0.999871	0.999884
1°	1.000072	0.999928	0.999941
2°	1.000031	0.999969	0.999982
3°	1.000009	0.999991	1.000004
4°	1.000000	1.000000	1.000013
5°	1.000010	0.999990	1.000003
6°	1.000030	0.999970	0.999983
7°	1.000067	0.999933	0.999946
8°	1.000114	0.999886	0.999899
9°	1.000176	0.999824	0.999837
10°	1.000253	0.999747	0.999760
11°	1.000345	0.999655	0.999668
12°	1.000451	0.999549	0.999562
13°	1.000570	0.999430	0.999443
14°	1.000701	0.999299	0.999312
15°	1.000841	0.999160	0.999173
16°	1.000999	0.999002	0.999015
17°	1.001160	0.998841	0.998854
18°	1.001348	0.998654	0.998667
19°	1.001542	0.998460	0.998473
20°	1.001744	0.998259	0.998272

II. Table for determining the density of Air at different pressures and temperatures.

The logarithm of the density of air is obtained by adding the logarithm of $h - 0.378 \times \frac{2}{3} e_t$ in centimetres to $\log A_t$ (§ 8), where e_t is the maximum pressure of aqueous vapour at $t^\circ\text{C}$. and $A_t = 0.00129384 / (1 + 0.00367 t) \times 76$.

Values of the logarithms of A_t .

t .	Log. A_t	Diff.	t .	Log. A_t .	Diff.
10°	$\bar{5}.2154123$		15°	$\bar{5}.2077924$	
11°	$\bar{5}.2138776$	15347	16°	$\bar{5}.2062843$	15081
12°	$\bar{5}.2123483$	15293	17°	$\bar{5}.2047815$	15028
13°	$\bar{5}.2108244$	15239	18°	$\bar{5}.2032838$	14977
14°	$\bar{5}.2093057$	15187	19°	$\bar{5}.2017913$	14925
15°	$\bar{5}.2077924$	15133	20°	$\bar{5}.2003039$	14874

Values of $0.378 \times \frac{2}{3} e_t$, where e_t is the maximum pressure of aqueous vapour at $t^\circ\text{C}$. in centimetres of mercury at 0°C . according to Regnault's results.

t .	0	1.	2	3	4.	5	6.	7.	8.	9.
10°	.231	.232	.234	.235	.237	.239	.240	.242	.244	.245
11°	.247	.248	.250	.252	.253	.255	.257	.258	.260	.262
12°	.264	.265	.267	.269	.271	.272	.274	.276	.278	.280
13°	.281	.283	.285	.287	.289	.291	.293	.294	.296	.298
14°	.300	.302	.304	.306	.308	.310	.312	.314	.316	.318
15°	.320	.322	.324	.326	.328	.331	.333	.335	.337	.339
16°	.341	.343	.346	.348	.350	.352	.354	.357	.359	.361
17°	.363	.366	.368	.371	.373	.375	.378	.380	.382	.385
18°	.387	.390	.392	.395	.397	.400	.402	.404	.407	.409
19°	.412	.415	.417	.420	.422	.425	.428	.430	.433	.436
20°	.438	.441	.444	.447	.449	.452	.455	.458	.461	.463

III. Table for finding the percentage by mass of absolute alcohol in a given solution from a determination of its density.

Cf. Mendelejeff, Pogg. Ann. (1869), Bd. cxxxviii. 279.

Mass % absolute alcohol.	Mass % distilled water.	Density at 10°.	Density at 15°.	Density at 20°.
5	95	99114	99042	98946
10	90	98410	98316	98196
15	85	97817	97683	97528
20	80	97264	97081	96878
25	75	96673	96446	96186
30	70	95999	95703	95403
35	65	95175	94849	94515
40	60	94256	93901	93512
45	55	93255	92876	92494
50	50	92183	91797	91401
55	45	91075	90679	90276
60	40	89945	89537	89130
65	35	88791	88378	87962
70	30	87614	87200	86782
75	25	86428	86007	85581
80	20	85216	84793	84367
85	15	83968	83544	83116
90	10	82666	82247	81801
95	5	81292	80863	80434
99	1	80101	79678	79256
99.1	.9	80070	79647	79225
99.2	.8	80039	79616	79194
99.3	.7	80008	79586	79163
99.4	.6	79977	79555	79133
99.5	.5	79946	79524	79102
99.6	.4	79915	79493	79071
99.7	.3	79884	79462	79040
99.8	.2	79853	79431	79009
99.9	.1	79821	79399	78977
100	0	79789	79368	78946

DESCRIPTION OF THE PLATES.

Plate I. General view of a balance made by Oertling.

Plate II. Front elevation of the same (full size).

Plate III. fig. 1. Plan of the same.

„ fig. 2. Side elevation of the same as far as the line *XY*.

„ fig. 3. Side elevation of the part of the beam to the left of the line *XY*.

In Plates II. III. the arrestment has been lowered more than it actually is, in order to show the central part of the beam : in Plate III. fig. 1. the gravity bob and vane are supposed to have been removed.

The letters refer as under :—

B the beam of the balance.

C the column.

K the central knife-edge.

D the brass bar to which the central knife-edge is attached.

S the screws attaching the central knife-edge.

c the cylinders by which the arrestment raises the beam.

k the terminal knife-edge.

b the box to which it is attached.

ss the locking screws.

σσ the adjusting screws.

p the pan-suspension planes.

h the hook for suspending the pans.

π the pointer.

g the gravity bob.

v the vane.

A the arrestment.

qq the pins for raising the pan-suspension planes.

r the rod of the rider.

ρ the bar on which it slides.

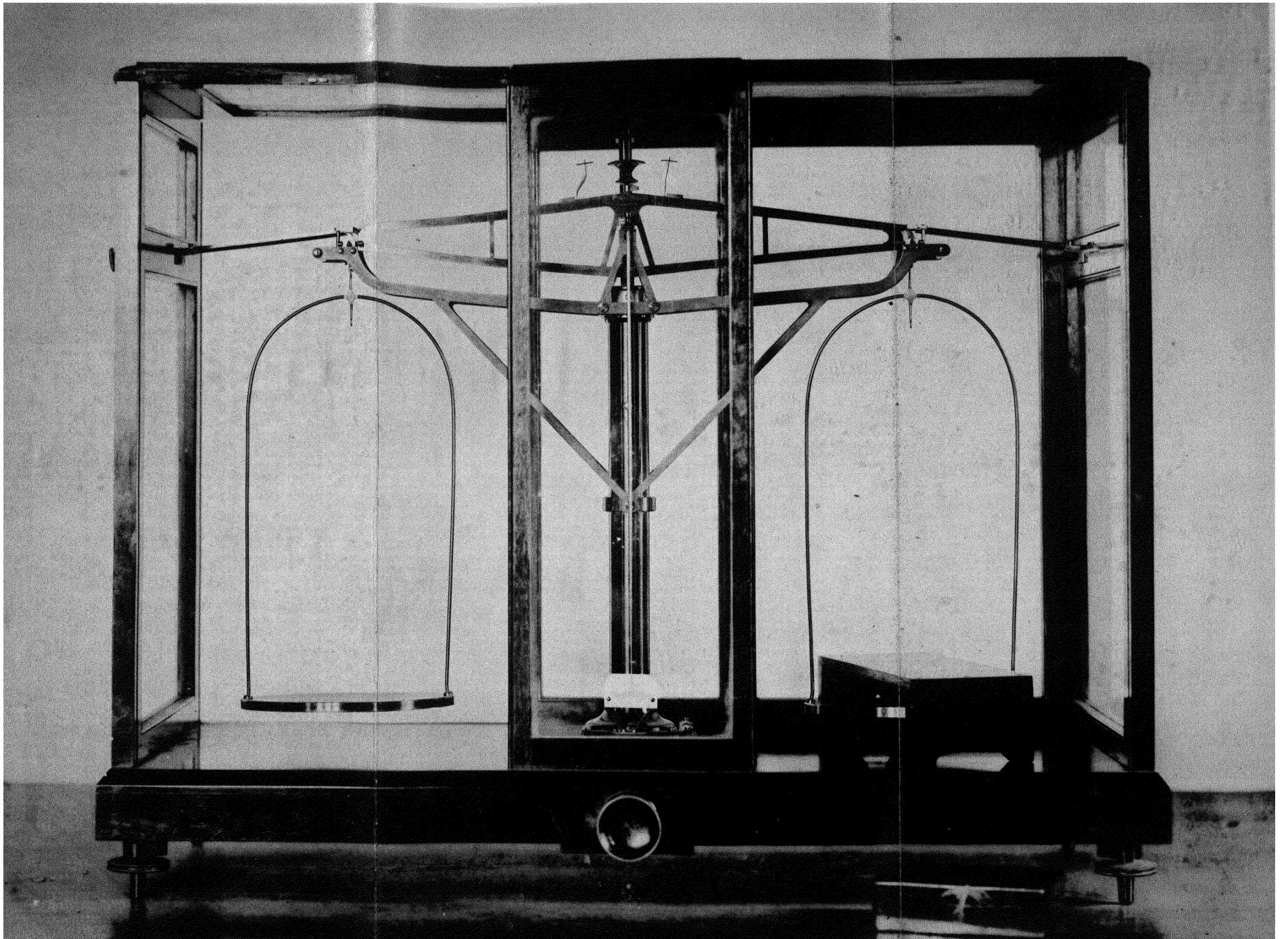

fig. 1.

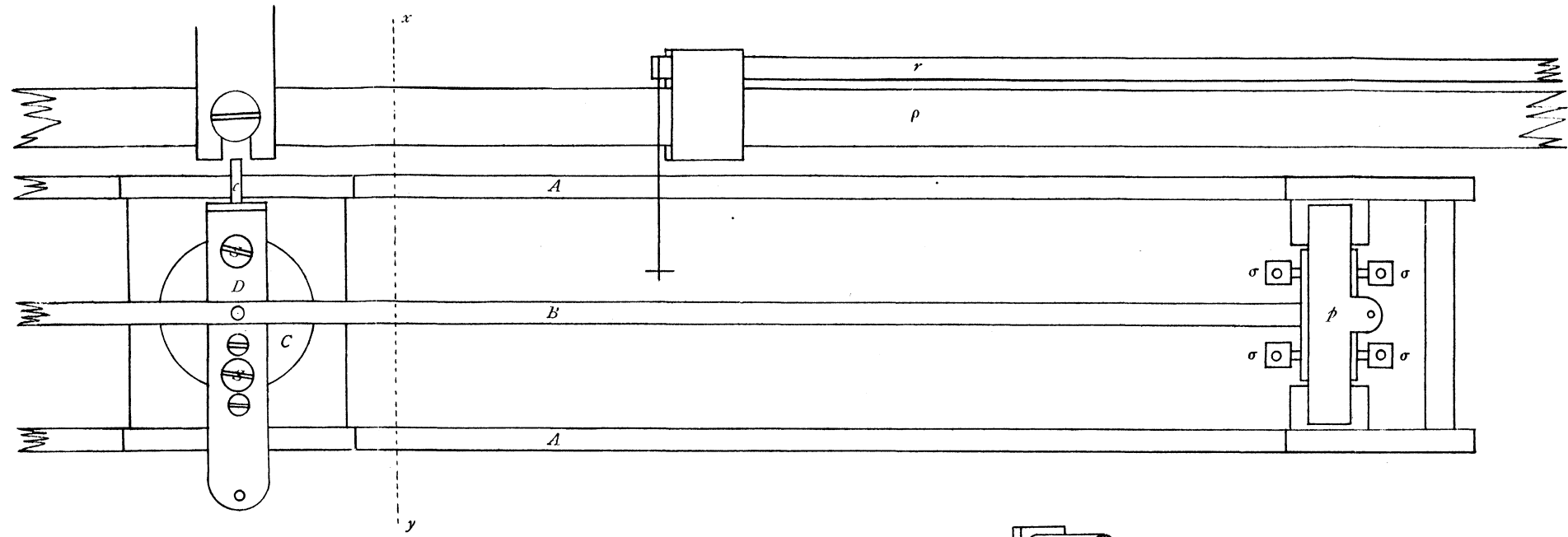

fig. 2.

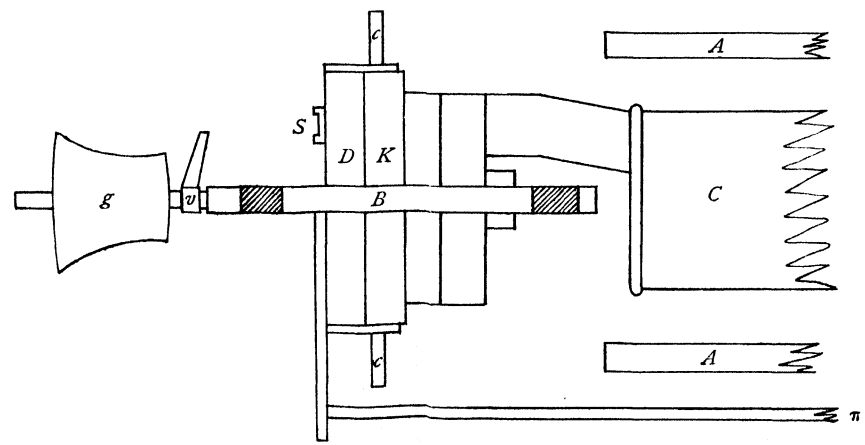

fig. 3.

