

# **DAMAGE BOOK**

UNIVERSAL  
LIBRARY

**OU\_156789**

UNIVERSAL  
LIBRARY



NOTES ON  
MICROSCOPICAL TECHNIQUE  
FOR ZOOLOGISTS

*“ . . . and then my wife and I with great pleasure, but with great difficulty before we could come to find the manner of seeing any thing by my microscope. At last did with good content, though not so much as I expect when I come to understand it better.”*

SAMUEL PEPYS 14th August 1664.

NOTES ON  
MICROSCOPICAL TECHNIQUE  
FOR ZOOLOGISTS

BY

C. F. A. PANTIN, Sc.D., F.R.S.

*Reader in Invertebrate Zoology in  
the University of Cambridge*

CAMBRIDGE  
AT THE UNIVERSITY PRESS

1948

*Printed in Great Britain at the University Press, Cambridge*  
*(Brooke Crutchley, University Printer)*  
*and published by the Cambridge University Press*  
*(Cambridge, and Bentley House, London)*  
*Agents for U.S.A., Canada, and India: Macmillan*

*First Edition 1946*  
*Reprinted 1948*

# CONTENTS

<i>Preface</i>	page vii
<i>Reference Books</i>	viii
<b>Part I. GENERAL METHODS</b>	
Methods of observation	1
Preparation of material	2
Narcotization	5
Fixation	8
Dehydration	13
Washing	18
Clearing	19
Storage: Mounting media	20
Whole mounts	22
Preparation of Frozen sections	26
Preparation of Paraffin sections	28
Preparation of Celloidin sections	33
Staining Paraffin sections	37
Preservation of sections	48
Drawing, Reconstruction, Micrometry	49
<b>II. SPECIAL METHODS</b>	
Nervous system	54
Cytoplasmic inclusions	55
Specific constituents	55
Special methods for Protozoa, etc.	57
<b>III. APPENDIX</b>	
Cultivation of organisms	63
Saline Media	63
Physical and Chemical data	69
Preparation of Records	69
<i>Fact Index</i>	71
<i>Reference Index</i>	78
<i>Addenda</i>	75
<i>Memoranda</i>	79



## PREFACE

THE following notes are based upon methods which have been found satisfactory by the staff of the Department of Zoology, Cambridge University, during the instruction of advanced students and those commencing research in zoology. Experience shows that the student needs some guide through the embarrassing number of methods offered to him by current handbooks of microscopy and histology. A selection of standard methods is therefore given here, and these are accompanied by comments on the principles which underlie their use. They are set out in a form suitable for use on the laboratory bench. In addition to these, other information and references are given to be a guide in a variety of problems which arise in connexion with microscopical work.

It is a pleasure to thank Dr S. M. Manton, Mr J. E. Smith, Dr S. Smith and Dr A. Stock and others for many valuable suggestions made during the compilation of these notes, and to thank Mr J. R. G. Bradfield for checking numerous calculations.

C. F. A. P.

## NOTE TO SECOND IMPRESSION

THE reprinting of this book has given me the opportunity to make a few corrections and additions.

C. F. A. P.

1948

## REFERENCE BOOKS

*For the use and Care of the Microscope* see:

Gage, S. H. (1936). *The Microscope*. 16th ed. New York: Comstock Publishing Co.

And for an introductory account see:

Beck, C. (1942). *The Microscope*. London: R. and J. Beck, Ltd.

*For all ordinary histological operations*, follow the directions given in:

Carleton, H. M. (1938). *Histological Technique*. Oxford University Press.

Note the sections on errors and their remedies.

*For special methods* refer to:

Gatenby, J. B. and Painter, T. S. (1937). *The Microtometist's Vade-Mecum*, 10th ed. London: J. and A. Churchill.

Cowdry, E. V. (1943). *Microscopic Technique in Biology and Medicine*. (Extensive indexes and references to current methods.) Baltimore: Williams and Wilkins.

Langeron, M. (1934). *Précis de Microscopie*. Paris: Masson et Cie.

Romeis, B. (1932). *Taschenbuch der mikroskopischen Technik*. Munchen and Berlin: R. Oldenbourg.

*For histochemistry*:

Lison, L. (1936). *Histochemie animale*. Paris: Gauthier-Villars.

*For the theory of fixation and staining*:

Baker, J. R. (1945). *Cytological Technique*. 2nd ed. London: Methuen. (Methuens' Monographs on Biological Subjects.)

References to all other works are given in full in the text. The well-known *Microtometist's Vade-Mecum*, the editorship of which varies with its editions, is referred to by its title.

# Part I

## GENERAL METHODS

---

---

### METHODS OF OBSERVATION

(a) *Direct observation* under the microscope, of living or fixed material, stained or unstained, should be made under critical optical conditions. See Gage, S. H. (1936), or Beck, C. (1942).

(b) *Dark-ground illumination*. See Carleton (1938), chap. ix. Useful for observation of cilia, granules, etc., in living material.

(c) *Phase difference microscopy*. A new method for unstained material. Tissue and cell constituents are brilliantly differentiated by optical interference. See Burch, C. R. & Stock, J. P. (1942), *J. Sci. Instrum.* **19**, 71. Martin, L. C. (1947, *Nature, Lond.*, **159**, 827) gives a general account.

(d) *Muscular anatomy by polarized light* (Imms's method). Mount in balsam and observe under crossed nicols. The relations of the striated muscles of arthropods are very clearly shown.

(e) *Polarized light and birefringence*. For a general account of the theory of polarization see the *Encyclopaedia Britannica*, various editions. For the use of polarized light in the analysis of crystalline and other structures see:

Winchell, A. N. (1933). *Elements of Optical Mineralogy*. Part I, 'Principles and Methods', New York: J. Wiley and Sons; London: Chapman and Hall.

Ambrohn, H. and Frey, F. (1926). *Das Polarisationsmikroskop*. Leipzig: Akademische Verlagsgesellschaft M.B.H.

(f) *Micellar structure by birefringence*. Birefringence in histological structure may be due to the *intrinsic* properties of the molecules of some substance composing it, or it may be of *structural* origin owing to the presence of orientated micelles or aggregates of molecules. Structural birefringence disappears in a medium of the same refractive index as the micelles, the whole then becoming optically homogeneous (Picken, L. E. R. (1940),

*Biol. Rev.* 15, 133). This disappearance can be sought by mounting objects successively in a series of media of graded refractive index such as follows:

	N		N
Distilled water	1.33	Cedar oil	1.51
C <sub>2</sub> H <sub>5</sub> OH	1.36	Creosote	1.54
50 % glycerol in water	1.40	Aniline	1.58
Glycerol	1.47	α-Chloronaphthalene	1.63
Liquid paraffin	1.47	α-Bromonaphthalene	1.66
Castor oil	1.49		

See also *Handbook of Chemistry and Physics*, 21st ed., p. 1618 (Cleveland, Ohio, U.S.A.: Chemical Rubber Publishing Co.).

By the use of optical wedges and plates further important information can be gained concerning the sign of the birefringence: see the references in the preceding section (*e*).

(*g*) *Electron microscope*. See v. Ardenne, M. (1940), *Electronen-Übermicroscopie*. Berlin: Julius Springer. (Lithoprint reproduction by Edwards Brothers, Ann Arbor, Michigan.) For a brief popular account see *Discovery* (1943), 4, 311. At present, this instrument is only suitable for objects of very small size which can be safely examined dry and *in vacuo*. Their thickness should not exceed about 2 $\mu$ . Differentiation of internal structure in an organic particle is very difficult to obtain, but the correct outline of an object can be seen under enormous magnification (e.g. 1 : 40,000).

## PREPARATION OF MATERIAL

### (a) EXAMINATION OF LIVING MATERIAL

Always examine material alive if possible; the information gained is often as unexpected as it is valuable. Mount objects on a microscope slide under a large cover-slip.

*With oil-immersion objectives* mount the object with as little water as possible under a very large cover-glass and use very thin cedar oil. Otherwise the object will move during focusing. Leitz's 'Nelkenöl' is useful.

*A hanging drop* on the under-surface of a cover-glass on a cell is best for the examination of minute organisms. It permits use of immersion objectives and allows free access of air to the specimen. The drop should be as shallow as possible. A cell may be

conveniently constructed on a slide from superimposed rings of thick blotting paper (made with the aid of cork-borers). The upper and lower surfaces should be lightly coated with vaseline for adhesion to slide and cover-slip. Dampen the blotting-paper cell to prevent evaporation of the hanging drop.

*A cellophane compressorium* is useful to hold small organisms in place. Place the organism in a little water on a cover-slip. Cover it with a small square of thin wet cellophane. Blot away excess water till the organism is held and flattened as desired. Press the edges of the cellophane firmly on to the cover-slip with blotting-paper. Invert the cover-slip over a cell, as with a hanging drop. Despite compression oxygen can still reach the organism through the cellophane.

*Narcotization*, if mild (e.g. by 10 % alcohol or by isotonic  $MgCl_2$  solution), leaves ciliary mechanisms functioning normally and greatly simplifies examination.

*To slow cilia* partially anaesthetize with tobacco smoke (see under 'Narcotics'). Alternatively, increase acidity slightly with HCl (pH 5-6) or with a trace of acetic acid. Viscous solutions of gum arabic are also useful: their effect is probably partly due to osmotic dehydration.

*Heat radiation* from intense light sources rapidly kills many organisms. To absorb it place a jar between the light source and the microscope, and fill it with a solution of

Powdered ammonium ferrous sulphate	200 g.
25 % $H_2SO_4$	5 c.c.
Distilled water	1000 c.c.

Dissolve without heat. The solution remains good for 6 weeks.

### (b) TISSUE CULTURE

For methods see references in the *Microtometist's Vade-Mecum*, 10th ed., p. 250. An elementary method for *Helix* tissue is given by Gatenby, J. B. (1937), *Biological Laboratory Technique* (London: Churchill).

### (c) MICROMANIPULATION

*Microdissection*. For technique see *Handbook of Microscopical Technique* (1937), ed. by C. E. McClung, Oxford University Press, or in the *Microtometist's Vade-Mecum*, 9th ed. (1928).

*Minute dissections* (crustacean mouthparts, etc.). Harding, J. (1939, *J. Roy. Micr. Soc.* 69, 19) describes an elegant instrument for minute dissection. Fine needles are mounted in holders with simple micro-movement obtained on the principle of a pantograph. The needles themselves are best made by dipping a fine tungsten wire in molten  $\text{NaNO}_2$ . This leaves a very fine point.

See also Komp, W. H. W. (1942), *Publ. Hlth Rep., Wash.*, 57, 1327.

*Fine scalpels* of all sizes can be made as follows. Place a hard steel safety-razor blade obliquely between two level blocks of hard wood held in a vice (Fig. 1). Snap off the upper part of the razor blade by pressing it over with a flat piece of wood. A sharply pointed blade remains held between the blocks. Mount this blade in a cleft stick or mapping-pen holder with the aid of marine glue or sealing wax.

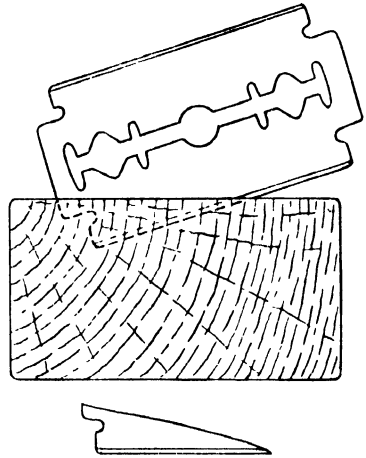

Fig. 1

#### (d) EXAMINATION OF ISOLATED CELLS

*Goodrich's method* (1942, *Quart. J. Micr. Sci.* 83, 245). Prepare a saturated solution of boric acid in 0.75% NaCl (sea water or Ca-free sea water for marine forms). Add about 2 drops of Lugol's iodine per 25 c.c. solution, giving the latter a pale yellow colour. Immerse the organism or tissue in a small volume of the solution in a small dish. The intercellular matrix dissolves, and after 2-3 days the individual cells will fall apart. Gently tap the dish to separate the cells. The cells will keep in saturated boric acid for many days, or even weeks. The method succeeds with a great variety of animals and their tissues, e.g. *Hydra*, *Lumbricus*, rabbit.

*Ranvier's method.* Macerate the tissue for 24 hr. in 30% alcohol.

(e) PRESERVATION OF NATURAL SHAPE

The shape of an active organism may be instantly preserved by plunging it into absolute alcohol cooled in liquid air (Lissmann, H. W. (1945), *Nature, Lond.*, 156, 391).

NARCOTIZATION

If possible, avoid narcotization. Prolonged exposure to any narcotic adversely affects cell structure and ends in cytolysis. It is, however, often necessary to narcotize to prevent distortion and rupture on fixation, and for work on living organisms and tissues. Always narcotize gently by gradual addition of the narcotic without violent mechanical stimulation. The following special methods are recommended.

SPECIAL METHODS

(a) ANIMALS LIABLE TO DISTORTION

The following method can be used in preparing most kinds of small worm for fixation preparatory to section cutting, or for arranging organisms (such as *Hydra*) for whole mounts.

According to the size of the animal, coat a dried cover-slip or slide with paraffin wax. Narcotize the animal in a drop of natural medium on the cover-slip, or by means of the slide lift the already narcotized animal out of a dish of narcotizing medium.

Drain off excess fluid. Gently adjust the animal with a paint brush. For small animals on cover-slips, cover with cigarette paper moistened with narcotic, folding the edges on to the back of the cover-slip. Then drop the whole face downwards on a dish of fixative. For larger animals on slides, cover with a strip of cigarette paper. If necessary wind a piece of wool lightly round the slide to hold all in place. Immerse in fixative. If animals are very sticky use, in place of the cigarette paper, a piece of old fine bolting silk lightly rubbed with wax.

Do not try to remove animals from cover-slip or paper till fixation is complete. If they adhere at all strongly take animal, cover-slip and paper to the clearing medium. The cover-slip then comes away through solution of the wax and the paper can be removed with less danger.

Perform all operations smoothly and deftly. Avoid continual readjustment of the animal. When flaccid under narcosis its tissues are very easily damaged. If the animal is slightly disarranged, carry on: contraction on fixation will pull it straight. If you must rearrange it, flood with narcotizing medium, take up the animal and start again.

#### (b) SESSILE ANIMALS

If already retracted, narcotics often fail to relax these. This is sometimes due to special properties of the muscles (Actinozoa), and sometimes to expansion itself being in part an active process resulting from muscular contraction. Therefore, let the animals first become naturally expanded by placing them in clean water and leaving them for some hours in a quiet, cool and dimly lit dish of the smallest convenient size. Then anaesthetize gently and gradually in the same dish. Do not subject them to mechanical agitation. In particular, avoid transferring the animals from one dish to another. To fix, gently remove as much fluid as possible without disturbing the animal and then smoothly and rapidly fill the dish with fixative by running it into the bottom of the dish from a large pipette. Repeat, if excess medium has unduly diluted the fixative.

#### NARCOTICS

The following are recommended for all general purposes:

(a) 10% alcohol. Recommended for fresh-water animals. Make up from absolute alcohol not from low-grade spirit because this contains deleterious substances. Add the 10% alcohol a little at a time waiting till excitation subsides before adding more. Excellent for *Hydra*, flatworms, etc. Narcotizes in a few minutes to an hour according to species.

(b)  $MgCl_2$ . Recommended for marine animals including many sessile kinds (e.g. Actinozoa). Sea water diluted with an equal volume of isotonic magnesium salt solution is an ideal anaesthetic. Use 7.5%  $MgCl_2 \cdot 6H_2O$ , or 20%  $MgSO_4 \cdot 7H_2O$ . Superficial narcosis occurs in a few minutes. After it has supervened general narcosis may be hastened by gently injecting isotonic magnesium solution internally.

M/8 magnesium salts (2.5%  $MgCl_2 \cdot 6H_2O$ ) slowly narcotizes fresh-water animals. It requires about 2 hr. for flatworms.

(c) *Menthol*. Recommended for difficult sessile organisms, both marine and fresh water (e.g. Polyzoa). Let the animal expand in clean water in a quiet place, scatter a few crystals of menthol on the surface and leave overnight.

(d) *Ether vapour*. Recommended for insects, arachnids and terrestrial vertebrates.

(e) *Tobacco smoke* is an excellent narcotic for many ciliates (e.g. *Paramecium*) and flagellates. It can also be used to slow and stop the cilia of *Mytilus*, and to narcotize *Hydra*. Fill a short tube with the smoke. Invert over its mouth a slide carrying the specimen in a drop of fluid. Watch under a low power and remove the slide as soon as narcotization is complete ( $\frac{1}{4}$ –1 min.). The vapour from a drop of pyroligneous acid acts similarly but more slowly.

If these methods fail try

(f)  $\text{CO}_2$ . Squirt a little soda-water from a siphon into the water in which the animals are living.

(g) *Ethyl urethane*, 0.3–1.0 % in water or the appropriate natural medium. This acts very gently and slowly (about 12 hr. for *Lumbricus* and *Sabella*). For vertebrates inject a solution in saline at body temperature.

Chloretone (0.005–0.05 %) or chloral hydrate (2 %) may also be used.

(h) *Rousselet's solution* (J. R. Baker's modification). Recommended for Rotifera. It must be freshly prepared:

2 % cocaine HCl	3 c.c.
90 % alcohol	1 c.c.
Distilled water	6 c.c.

Cocaine is unstable in solution. Eucaine, which is stable, may be substituted.

(i) *Gentle heating*. Slowly raising the temperature towards the death-point (30–35° for British marine animals) may induce paralysis of the nervous system in a relaxed organism before adverse histological changes occur. Allow organisms to relax overnight in a bowl of water above a radiator at a suitable temperature.

---

## FIXATION\*

The ideal fixative varies with the tissue, and one of the histologist's objects is to find the best fixative for the work in hand. But Heidenhain's 'Susa', Bouin, and 'Flemming-without-acetic' are fixatives which, each for its own purpose, give very satisfactory results with a wide range of material. As in all histological work success in fixation depends on practice and familiarity with the method. Do not therefore use elaborate methods of fixation unless you have special reason. Moreover, if the standard method fails, be certain that this is not due to lack of practice before passing to another method. If animals contract rapidly on fixation it may be necessary to warm the fixative, thus Wilson, D. P. (1932, *Philos. Trans. B*, **221**, 237), uses Bouin at 30-60°C. for the fixation of polychaete larvae. Do not try to fix too large an organism or piece of tissue. If the object is large, cut off a small portion and contrive to open up the structures to be studied to the fixative. All parts of the tissue should be within a few mm. of the surface exposed to the fixative.

Most fixatives act by precipitating protein constituents in such a way that the cell and its contents retain in some degree the shape they possessed in life. But often during their action, and still more during subsequent dehydration, important cellular constituents are removed, that is, the lipoids. To preserve these, special fixatives, such as Baker's Formaldehyde-calcium, are needed and fat solvents must be avoided in subsequent treatment.

## A. MICRO-ANATOMICAL FIXATIVES

(1) *Heidenhain's Susa*. Probably the best general fixative there is for material to be sectioned. Almost all stains act well on Susa-fixed material. Gross cell structures, e.g. protonephridia, are preserved well, but fine cytological detail, e.g. mitochondria, Golgi bodies, etc., is not. Its composition is:

HgCl <sub>2</sub>	45.0 g.	Trichloroacetic acid	20 g.
NaCl	5.0 g.	Acetic acid (glacial)	40 c.c.
Distilled water	800 c.c.	Formalin (40% HCHO)	200 c.c.

The first three items may be made up as a stock laboratory

\* See also Addenda, p. 75.

solution. For some marine animals (though not for all) there is advantage in raising the NaCl content to 30 g. NaCl instead of 5 g. or substituting sea water for distilled water.

Fix for 3–24 hr.

Since collagen swells in aqueous media after exposure to trichloroacetic acid, transfer *direct* to 96 % alcohol (p. 17). This should be made pale brown by tincture of iodine to remove any precipitate formed by the mercury. Do not touch fixative with metal: use a pipette, or wooden spills, or paint brushes mounted in glass or quills as sold by pharmacists.

(2) *Bouin*.

Picric acid, saturated aqueous solution	75 c.c.
Formalin (40 % HCHO)	25 c.c.
Acetic acid (glacial)	5 c.c.

Solution keeps indefinitely.

Fix 12 hr. or longer. Transfer direct to 70 % alcohol (p. 15).

Material may be left in Bouin indefinitely. This makes it very suitable for use on collecting expeditions.

It is an excellent fixative for marine Invertebrata and most mammalian tissues; good for nuclei; poor for cytoplasmic inclusions; bad for vertebrate kidney and some organisms containing numerous mucin cells. In these there may be great distortion owing to swelling and shrinkage. Addition of urea 1 % (Bouin-Allen) improves kidney fixation.

(3) *Duboscq-Brasil* (= *alcoholic Bouin*).

Picric acid	1 g.	Formalin (40 % HCHO)	60 c.c.
Acetic acid (glacial)	15 c.c.	80 % alcohol	150 c.c.

A highly penetrating fixative suitable for animals covered by an impervious cuticle (Arthropoda, etc.). Fix for 2 hr. or more. Transfer direct to 90 % alcohol (p. 16). With large or very impermeable specimens fixation must be longer, but if greatly prolonged it causes brittleness.

To prevent hardening in *Peripatopsis*, Manton (1937, *Philos. Trans. B*, 227, 413) found it desirable to fix for not more than 2 hr. and to complete the whole process of dehydration and embedding in less than 24 hr.

(Carnoy, see p. 11, is also a highly penetrating fixative. Sometimes good for micro-anatomy of delicate tissues.)

(4) *Zenker.*

HgCl <sub>2</sub>	5.0 g.	Na <sub>2</sub> SO <sub>4</sub> .H <sub>2</sub> O	1 g.
K <sub>2</sub> Cr <sub>2</sub> O <sub>7</sub>	2.5 g.	Distilled water	100 c.c.

The above can be made up as stock solution.

Acetic acid (glacial) 5 c.c. added just before use.

For flatworms, substitute formic for acetic acid (*Microtomist's Vade-Mecum*, 10th ed., p. 60).

Fix 3–12 hr. Wash 12–24 hr. in running tap water. Then transfer to 50 % alcohol (p. 18).

Zenker preserves fine cytoplasmic structure (mitochondria, etc.) better than Susa. It must, however, be freshly prepared because it contains both oxidizing and reducing substances which destroy each other after some hours. Treatment after fixation is more elaborate than with Susa. It should not, therefore, be used by the beginner until Susa fixation is thoroughly mastered.

There are several good variants of Zenker useful for special purposes, e.g. Zenker-formol (Helly).

## B. CYTOLOGICAL FIXATIVES

Strangeways, T. S. P. and Canti, R. G. (1927, *Quart. J. Micr. Sci.* 71, 1) have shown that while many useful fixatives such as HgCl<sub>2</sub> may preserve the cell outline, the appearance of the fixed cytoplasm differs entirely from that seen in the living state. Cells fixed in OsO<sub>4</sub> solutions, on the other hand, give a very faithful picture of the living cytoplasm. The penetrating power of OsO<sub>4</sub>, however, is feeble, and the inner parts of tissues are therefore poorly fixed by it. On the other hand, the outer parts are often overfixed; they shrink and undergo changes which prevent good staining. Osmic fixatives should therefore be used for the study of cytoplasmic structures within easy reach of the fixative, but not for the study of micro-anatomy.

All osmic fixatives keep badly and should be made up fresh. Keep in a clear bottle in a box or cupboard. You cannot perceive deterioration through a black bottle. Osmic vapour has a bad effect on the eyes and throat. OsO<sub>4</sub> is neutral, not acid.

While osmic fixatives preserve cytoplasmic structure, they do not fix nuclei well. These are best preserved by the action of acetic acid which, however, has an adverse effect on cytoplasmic

structure. For cytological work one must choose whether to preserve the nuclear or the cytoplasmic structures.

(a) NUCLEAR FIXATIVES

(1) *Bouin* is useful for chromosome work.

(2) *Carnoy*.

Absolute alcohol	60 c.c.
Chloroform	30 c.c.
Acetic acid (glacial)	10 c.c.

Fix for 10 min. to 3 hr. Transfer to 96% alcohol (several changes) (p. 16).

Both (1) and (2) preserve cytoplasmic structure poorly.

(3) *Aceto-carmin* is recommended for chromosome studies (*Microtometist's Vade-Mecum*, 10th ed., p. 142). Tease preparations with rusty needles: the trace of iron so obtained is important.

(4) *For special methods* see Darlington, C. D. and La Cour, L. F. (1942), *The Handling of Chromosomes*. London: Allen and Unwin.

(b) CYTOPLASMIC FIXATIVES

(1) *Gatenby's 'Flemming-without-acetic'* (*Microtometist's Vade-Mecum*, 10th ed., pp. 33 and 304) is an excellent cytoplasmic fixative.

1% chromic acid	15 parts
2% OsO <sub>4</sub>	4 parts

To this should be added enough NaCl to make it roughly isotonic:

For marine invertebrates add of 15% NaCl 5 parts.

For other organisms add of 15% NaCl 1 part.

For small and delicate objects the 'F.W.A.' may be diluted two or three times. Keep dilute mixtures isotonic.

*F.W.A. will not keep and it is expensive. Make up small amounts as required.*

Fix pieces of tissues not more than 5 mm. in diameter in strong F.W.A. for 24 hr. Wash 2-5 hr. in running tap water. Transfer to 30% alcohol. Dehydrate by gentle stages, several hours in each stage (p. 16).

(2) (a) *Formalin*, and (b) *Baker's Formaldehyde-Calcium* (1944, *Quart. J. Micr. Sci.* 85, 1).

(a) Commercial formalin, or formol, contains about 40% of formaldehyde (methanal) together with a variety of impurities which may or may not play some part in its properties as a fixative. If diluted to eight times its volume with water, the resulting formalin (5% HCHO) is a good cytoplasmic fixative which preserves lipoids. It is also used for certain kinds of nerve fixation. To prevent distortion consequent on osmotic changes during fixation it should be made up in sea water for marine animals, and in suitably diluted saline for others (e.g. 0.7% NaCl for terrestrial vertebrate tissues). Fix 48 hr. If lipid preservation is unimportant transfer direct to 50-70% alcohol (p. 16).

Formalin is one of the few penetrating fixatives which can be used neutral and will therefore preserve calcareous structures. For neutral formalin add powdered  $\text{CaCO}_3$  and a trace of phenol red as indicator. Shake and let settle. Do not use borates: they macerate. If for any reason Ca must be avoided, use  $\text{NaHCO}_3$ . Prepare neutral formalin as required. It may oxidize on long standing.

(b) All these advantages are combined in Baker's Formaldehyde-calcium, particularly recommended for preservation of Golgi bodies and other cell lipoids. It is

Formalin (40% HCHO)	10 c.c.
10% $\text{CaCl}_2$ (anhydrous)	10 c.c.
Distilled water	80 c.c.
Powdered $\text{CaCO}_3$ in slight excess	

(For marine invertebrates use 10%  $\text{CaCl}_2$  (anhydrous) 40 c.c. and distilled water 50 c.c.)

Fix for 2-3 days.

This is a neutral fixative. The  $\text{CaCl}_2$  improves lipid fixation as well as preventing osmotic distortion.

To preserve lipoids, store specimens in bulk or in gelatine blocks in

Formalin (40% HCHO)	10 c.c.	10% $\text{CdCl}_2$	10 c.c.
10% $\text{CaCl}_2$ (anhydrous)	10 c.c.	Distilled water	70 c.c.
Powdered $\text{CaCO}_3$ in slight excess			

Avoid fat solvents in subsequent treatment. Special methods

are required for sectioning and staining; see section on 'Preparation of frozen sections', p. 26.

(c) FIXATION OF YOLK-LADEN CELLS

Yolk-laden cells and embryos need special treatment. In addition to Baker's Formaldehyde-Calcium (see above) the following is recommended:

*Smith's Formol-Bichromate:*

$K_2Cr_2O_7$	0.5 g.
Formalin (40 % HCHO)	10 c.c.
Acetic acid, glacial	2.5 c.c.
Distilled water	100 c.c.

Make up immediately before use; the bichromate and the formalin gradually destroy each other.

Fix 24 hr. Wash 12 hr. in running water. Transfer to formalin (4 % HCHO). Correct dehydration is important. It must be rapid to prevent brittleness, but if it is incomplete the material will be ruined. See 'Dehydration Chart' and the note on 'Dehydration of eggs and yolk cells' (pp. 14 and 17).

If jelly has to be removed, place eggs before fixation on blotting paper, remove jelly by slicing and rolling egg gently. Examine material for defects before proceeding.

C. FIXATION OF PROTOZOA

See special methods (p. 57).

DEHYDRATION

*Dehydrate thoroughly and remove alcohol thoroughly.* Failure to do this quite completely is the commonest cause of poor histological results. It leads to shrinkage and brittleness in paraffin, and deterioration of histological structure, defects for which the fixative sometimes unjustly gets the blame. Never return fluids to the bottles of absolute alcohol, xylene (xylol), etc., kept for use in preparing material for embedding. See the bottles are well stoppered and remain so except in actual use.

Make sure that alcohols of 90 % strength and over are correctly made up. For critical work it is safest to make them up directly

by volume from absolute alcohol. If made from rectified spirit, check the density which for

90 % alcohol at 15° C. is 0.834

95 % alcohol at 15° C. is 0.816

In rough laboratory practice commercial rectified spirit is sometimes used in place of 90 % alcohol, but since this may contain as little as 4 % water, the passage into it from 70 % alcohol may be a severe strain on delicate organisms.

In dehydration transfer from fixative to the appropriate stage in the following series. Use small quantities in a small corked specimen tube containing the specimen.

For ordinary micro-anatomical work:

50 % alcohol, 1–12 hr.

70 % alcohol, 1–12 hr.

90 % alcohol, 1–12 hr.

Absolute alcohol (two baths), 2–12 hr.

95 % alcohol (1–12 hr.) may with advantage be employed before absolute alcohol.

At each stage transfer the used alcohol to a dry dish lest a small specimen is accidentally thrown out.

For very small pieces of tissue (a few mm. across) these times may, if absolutely necessary, be cut down to a minimum of not less than  $\frac{1}{2}$  hr. for each diluted alcohol and an hour for the absolute baths.

In general, do not prolong immersion in absolute alcohol and concentrated alcohol beyond 12 hr.; they harden. Over-hardened specimens may be softened by soaking in a mixture of equal parts of alcohol, glycerol and distilled water.

For dioxane and other methods of dehydration, see Carleton (1938), and also Kisser, J. (1933, *Cytologia, Tokyo*, 4, 288).

*Dehydration of eggs and yolk cells.* Exposure to alcohol makes yolk harden and crumble. Therefore dehydrate rapidly. On the other hand, incomplete dehydration will ruin the specimen. The correct duration of dehydration is thus very important. It varies with the nature and size of the material. Very small permeable objects may be left no more than  $\frac{1}{2}$  hr. in each grade of alcohol. Larger and less permeable ones need more time.

It is advisable to avoid absolute alcohol because of its great

hardening action. This can be done by clearing from 95 % alcohol with methyl benzoate or methyl salicylate. Clearing may then be completed in cedar oil or benzene. Avoid xylene; it hardens.

Clearing and impregnating by *Peterfi's Celloidin-Paraffin* is recommended (p. 29).

*Fixation and dehydration of very small objects.* Cut off a piece of glass tubing about  $1\frac{1}{2} \times \frac{1}{4}$  in. Narrow one end very slightly in a flame. When cold, plug this end with pyroxylin wool. Pyroxylin is cellulose tetranitrate; it may explode if pressed into a hot tube. Stand the tube in fresh or sea water according to the habit of the animal. Let the liquid rise almost to the top of the tube. Pipette in a number of animals. Lift out the tube and drain away almost all the water through the pyroxylin. Stand tube in suitable fixative. Fixative may also be dropped down the tube if desired. After fixation, dehydrate by passing the whole tube through the alcohols. If desired, stain in passing. After thorough dehydration in absolute alcohol lift out the tube, drain it till about one-quarter full of alcohol. Stand the tube in a very small dish (cut-off end of a specimen tube will do) containing methyl benzoate or clove oil. These dissolve the pyroxylin (the methyl benzoate does so rapidly). Cover to exclude damp. The cleared specimens will fall to the bottom of the dish. If necessary they can be transferred to solutions of celloidin in these substances.

When the objects are numerous (e.g. marine eggs, embryos, etc.), fixation and dehydration can be done in the tube of a hand centrifuge. The specimens should be *gently* centrifuged to the bottom at each step and the supernatant fluid poured off. The objects can, if necessary, be carried in the centrifuge tube finally into hot wax ready for embedding (see special methods for Protozoa, p. 59).

## DEHYDRATION CHART

### *Bouin*

Fix 12-24 hr.



70 % alcohol (several changes to wash out picric), 24 hr.



90 % alcohol, 12 hr.



Absolute alcohol (two changes), 12 hr.

*Carnoy*

Fix 2-3 hr.

↓  
96 % (or absolute) alcohol (several changes), 6-12 hr.↓  
Absolute alcohol (one or two changes), 6-12 hr., or methyl salicylate (to prevent hardening).*Duboscq-Brasil*

Fix 2 hr.

↓  
90 % alcohol (several changes), 24 hr.↓  
Absolute alcohol (two changes), 12 hr.*Formalin (5 % HCHO)*

Fix 1-3 days.

↓  
70 % alcohol, 6-12 hr.↓  
90 % alcohol, 12 hr.↓  
Absolute alcohol (two changes), 12 hr.

The above scheme may be followed except when lipoids are to be preserved. Alcoholic dehydration should then be avoided.

*F.W.A.*

Fix for 24 hr.

↓  
Running tap water, 2-5 hr.↓  
30 % alcohol, > 3 hr.↓  
50 % alcohol, > 3 hr.↓  
70 % alcohol, > 3 hr.↓  
90 % alcohol, 12 hr.↓  
Absolute alcohol (one or two changes), 3 hr.

To clear in xylene, gradually add this till a mixture of  $\frac{1}{2}$  absolute alcohol +  $\frac{1}{2}$  xylene is reached, and then transfer to pure xylene.

*Schaudinn (for Protozoa)*

Fix 15 min. (as directed on p. 58).

↓  
50 % alcohol, 10-30 min.

↓  
70 % alcohol (light brown with iodine), 10-30 min.

↓  
90 % alcohol, 48 hr.

↓  
Absolute alcohol, 1 hr.

*Smith's Formol-Bichromate*

Fix 24 hr.

↓  
Running tap water, 12 hr.

↓  
Formalin (4% HCHO), 12-48 hr.

↓  
30 % alcohol,  $\frac{1}{2}$  hr.

↓  
50 % alcohol,  $\frac{1}{2}$  hr.

↓  
70 % alcohol,  $\frac{1}{2}$  hr.

↓  
95 % alcohol,  $\frac{1}{2}$  hr.

↓  
Methyl benzoate or methyl salicylate.

For subsequent treatment see section on clearing, p. 19.  
For impregnation, Peterfi's Celloidin-Paraffin method is recommended (p. 30).

*Susa*

Fix 3-24 hr.

↓  
96 % alcohol (light brown with iodine), 12 hr.

↓  
Absolute alcohol (two changes), 12 hr.

*Zenker*

Fix 4-6 hr.



Running tap water, 24 hr.



50 % alcohol, 5-10 hr.



70 % alcohol, 5-10 hr.



80 % alcohol (light brown with iodine), 24 hr.



80 % alcohol (without iodine), 24 hr.



96 % alcohol, 12 hr.



Absolute alcohol (two changes), 12 hr.

## WASHING

(1) To wash specimens in tap water cut off the bottom of a test-tube *A* (Fig. 2). Wire a small piece of fine bolting silk *B* tightly over mouth. For very small organisms first cover the mouth with filter paper. Stand the tube in a small dish filled with water, as in Fig. 2. Insert specimen *S*. Plug the top with a hollow cone of cotton-wool. Place under a dripping tap. At the end of washing fill a small specimen tube completely full of water. Take off the bolting silk with the washed specimens and touch the surface of water so that they sink to the bottom.

(2)  $K_2Cr_2O_7$ . See that this is thoroughly washed out in water after use of fixatives containing it. Otherwise it leaves precipitates.

(3)  $HgCl_2$ . This is removed by iodine in alcohol at some stage in dehydration. Usually the iodine is in turn sufficiently removed during the rest of dehydration. If not the *sections* may at some stage be passed through very dilute  $Na_2S_2O_3$  (Carleton (1938),

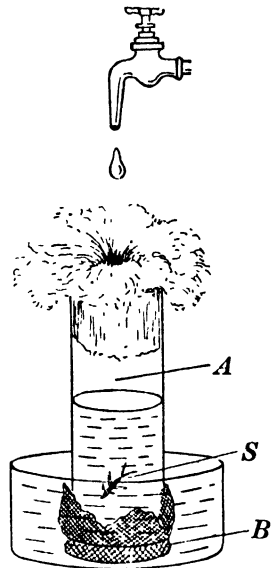

Fig. 2

p. 120), lest traces of iodine may inhibit staining. This procedure is rarely necessary.

(4) Picric acid should be completely washed out during dehydration. Traces increase electrification of paraffin ribbons.

---

## CLEARING

Discard clearing agents that have absorbed moisture. See that bottles are clean and dry before adding new clearing agent. Old stocks may have a film of water on the bottom. The efficiency of anhydrous  $\text{CuSO}_4$  in keeping xylene dry is uncertain.

(1) *Xylene*. Transfer from absolute alcohol to xylene till specimen is cleared: if less than 5 mm., for not more than 1 hr., for larger objects up to 6 hr. Keep for a minimum time in the xylene to prevent brittleness. Delicate objects may be transferred first to a mixture of  $\frac{1}{2}$  xylene +  $\frac{1}{2}$  absolute alcohol.

Test old xylene with litmus paper before use. If acid, shake with a little powdered  $\text{CaCO}_3$  and filter. A trace of alcohol in the xylene greatly increases its power to take up a trace of water left in the object.

Do not use xylene to clear yolky material: use methyl benzoate.

(2) *Cedar oil*. With a long thin dropping pipette run a few c.c. of cedar oil carefully to bottom of a small specimen tube containing the specimens in absolute alcohol. Specimens at first float at the interface. Gradually they clear and sink. Suck off the alcohol. Change the cedar oil after a few hours. Specimens can wait in cedar oil till required.

(3) *Methyl benzoate (or methyl salicylate), and benzene (or cedar oil)*. If specimens are to be embedded by Peterfi's Celloidin-Paraffin method (see p. 29), or if absolute alcohol must be avoided, methyl benzoate or methyl salicylate may be used as intermediate clearing agents. These are not completely soluble in paraffin, and before embedding in that, one must transfer the specimen to benzene or cedar oil.

Using the same method as for cedar oil above, transfer the specimen from absolute alcohol to methyl benzoate (or methyl salicylate). Where there is danger of hardening by absolute alcohol (yolk or chitinous material), transfer from 95 % alcohol.

Change the clearing agent twice or three times. Transfer to benzene or cedar oil; thence to paraffin wax or liquid paraffin.

### STORAGE

(1) Specimens are usually stored in 70 % alcohol.<sup>4</sup>

For most purposes a solution of

70 % alcohol	95 parts
Glycerol	5 parts

is better. Mislaid specimens do not desiccate completely in this.

A storage mixture of equal parts of alcohol, glycerol and distilled water (Strassburger-Flemming solution) prevents hardening, and softens dried material.

(2) Cedar oil is an excellent preservative, though expensive.

(3) Methyl benzoate, with or without celloidin, is a good preserving medium.

(4) Specimens to be sectioned can be preserved indefinitely when embedded in wax. But you can no longer see the specimen. *Liquid paraffin* however is an ideal preservative.

### MOUNTING MEDIA

#### *Refractive index*

	<i>N</i>	Soluble in
Hyrax	1.82	Xylene ('xylol') Benzene ('benzol')
Saturated aqueous solution of HgI <sub>2</sub> and KI	1.68	Water
Canada balsam	1.53	Xylene, benzene, etc.
Apáthy's gum-syrup	1.52	Water
Various artificial resins	1.51-1.54	Xylene, benzene, etc.
Euparal	1.48	Absolute alcohol, xylene
Glycerine jelly	1.47	Water
50 % glycerol and water	1.40	Water
Water	1.33	

Apáthy's gum-syrup is

Pure gum arabic	50 g.	Distilled water	50 c.c.
Pure cane sugar	50 g.	Thymol	0.05 g.

It is good for preservation of methylene blue and many other stains, though not haematoxylin. It sets hard.

Glycerine jelly is

Gelatine	10 g.	Glycerol	70 c.c.
Distilled water	60 c.c.	Phenol cryst.	0.25 g.

The ideal mounting medium for stained preparations should have the same refractive index as the mounted object. This is about  $N=1.54$  for fixed and cleared cell constituents. The refractive indices of Canada balsam and of various proprietary resins approach this value, and these are therefore excellent mounting media.

If it is an advantage to mount direct from absolute alcohol, or to avoid xylene (see section on fading of stains, p. 48), Euparal is recommended. The refractive index of this, however, is too low for optimal resolution of the finest structures with an oil-immersion objective. The defect is small, but critical resolution depends on attention to all small factors. But where the highest resolution is unnecessary, and where improved visibility of chitin, spicules, etc., is desired, Euparal is satisfactory.

### *Aqueous media*

When mounting in glycerol, Apáthy's syrup and other aqueous media, transfer from water not from alcohol. Glycerol media have a very high osmotic pressure which may cause collapse and shrinkage even in fixed specimens. Transfer delicate objects via intermediate dilutions of glycerol (many hours in each). Alternatively, place in excess of very dilute glycerol and slowly evaporate (cf. *Microtometist's Vade-Mecum*, 10th ed., p. 600).

Glycerol or water mounts must be sealed to prevent absorption or evaporation of water. Success depends on using thoroughly clean slides and cover-slips. After covering the object suck away all trace of fluid beyond the edge of the cover-slip. Do this with a pipette pulled out to a very fine point which has been bent through  $45^\circ$ . Then wipe round with pointed slips of clean filter paper, taking great care not to draw air under the edge of the cover-slip in so doing and not to move the cover-slip. Paint the edge with gold size. Give a second coat when the first is dry. The

best results are obtained if round cover-slips are used and the size laid on by a spin of a turn-table.

A thick solution of marine glue in xylene may be put on first. Build up the seal with several layers each applied when the previous one is dry. Marine glue never completely solidifies, and the slight flow with thermal expansion and contraction prevents cracking. Cover the marine glue seal with gold size.

Glycerine jelly is applied melted. Warm the jelly and warm the slide. Place a drop on a slide, transfer the organism on to the drop from 50 % glycerol without too much of the fluid. Cover with a warmed cover-glass. Try a blank slide and cover-slip first so as to gauge the quantities.

With Apáthy's syrup transfer direct from water. With delicate objects transfer to diluted syrup, and then concentrate as with glycerol (Langeron, 1934).

Polyvinyl alcohol provides a new aqueous mounting medium. Moreover, tissues can be embedded in it for section cutting (Lubkin, V. & Carsten, M. (1942), *Science*, 95, 633; Downs, W. G. (1943), *Science*, 97, 539).

## WHOLE MOUNTS: PREPARATION

### DISSECTION OF SMALL SPECIMENS

(a) For some purposes it is convenient to clear in clove oil, which makes the specimen brittle. Appendages are then easily removed.

(b) Mounts can be prepared to show the relations of internal structures by staining, embedding in paraffin and then slicing tissue away to permit adequate view. Dissolve the paraffin in xylene and mount.

### UNSTAINED OBJECTS

(a) *Setae, spicules, etc.* These are rendered most visible in media differing widely from them in refractive index, such as dilute aqueous media ( $N \doteq 1.33$ ), or a saturated solution of  $\text{HgI}_2$  in KI ( $N = 1.68$ ). Permanent mounts may be made in Euparal or glycerol jelly or in Hyrax ( $N = 1.82$ ; see *Microtomist's Vademecum*, 10th ed., p. 229).

(b) *Tracheae.* To demonstrate tracheae make a saturated

solution of Sudan black in a mixture of equal parts of olive oil and kerosene. Drop the fluid on the narcotized or freshly killed insect. The black fluid runs into the tracheal system, displacing the air. The insect may then be lightly rinsed in xylene and examined in air or in an aqueous medium.

(c) *Small arthropods (mites, etc.)*. A useful combined fixative and mounting medium is gum-chloral:

Gum arabic	50 g.	Glycerol	32 c.c.
Chloral hydrate	100 g.	H <sub>2</sub> O	100 c.c.

Leave slide in oven at 50° C. for a few days. Seal with gold size.

(d) *Resemblance to living condition*. Fix in formalin (5% HCHO) so as not to destroy fats. Mount in glycerol media. The refractive index of these is higher than water so that the clearing effect just about offsets the opacity due to fixation of the protoplasm. The index is, however, low enough for unstained setae, etc., to remain clearly visible.

(e) *Small and delicate objects* (e.g. Rotifera, *Volvox*, etc.). A dilute aqueous medium evades the necessity of subjecting the object to deformation during dehydration. The low refractive index permits even cilia to be seen unstained. With or without previous narcotization fix with a mild fixative, e.g. osmic vapour, or formalin (2% HCHO). Mount in formalin (2% HCHO) in 1% cupric acetate. It is best to mount in a shallow hollow-ground slide. This allows a very good seal. Use a No. 2 cover-slip. To avoid breakage use rather low powers (6 mm. or more). View direct and also under dark-ground illumination.

Ripart and Petit's fluid serves as a gentle fixative and a preservative for delicate organisms. It is

Camphor water	75 c.c.	Cupric acetate	0.30 g.
Distilled water	75 c.c.	Cupric chloride	0.30 g.
Acetic acid (glacial)	1 c.c.		

---

## WHOLE MOUNTS: STAINING

(a) *Borax Carmine* (Grenacher)

Make a concentrated solution of carmine by adding the powder to 4% borax solution and boiling the mixture for  $\frac{1}{2}$  hr. The liquid

is diluted with an equal volume of 70 % alcohol, allowed to stand for a time, and filtered.

*Short way.* Transfer the object to be stained from 70 % alcohol, or less, to the borax carmine. Stain until the object is just thoroughly penetrated (about 10 min.). Thoroughly differentiate in acid alcohol (4 drops of strong HCl to 100 c.c. of 70 % alcohol), until the object assumes a bright transparent appearance. Dehydrate in 90 % alcohol (10 min.); pass to absolute alcohol, two lots (5–30 min. each); clear in xylene and mount. Mounts are commonly spoilt by being far too heavily stained.

*Long way.* Stain for 6–24 hr. Differentiate in acid alcohol till outer layers look rather white and inner parts dirty pink. This takes several days to 6 weeks. On mounting, various organs show various shades of red and orange; outer tissues clear or yellow. An excellent method, particularly after Bouin fixation.

(b) *Ehrlich's Acid Haematoxylin*

Haematoxylin	2 g.	Absolute alcohol	100 c.c.
Acetic acid (glacial)	10 c.c.	Water	100 c.c.
Glycerol	100 c.c.	Alum in excess	

Dissolve the haematoxylin in the alcohol, then add the acid, then the glycerol and water. The mixture is allowed to ripen until it assumes a dark red colour. The stain improves with age.

Transfer to stain from 70 % alcohol. Stain until the object is of a dark blue-black colour. Wash in 70 % alcohol. Differentiate in acid alcohol, watching the process carefully. The object will turn a reddish colour and should be 'blued' by washing in tap water which is usually slightly alkaline, or may be rendered so by the addition of a drop of ammonia. Dehydrate, clear and mount.

(c) *Chlorazol Black E* (Cannon, H. G. (1941), *J. Roy. Micr. Soc.* 61, 88)

An excellent stain for 'Chitin' as well as being a good general stain. Stain progressively in a saturated solution of the stain in 70 % alcohol (about 20 min.), wash with 90 % alcohol and leave in this for some time, according to the thickness of the specimen. Clear as usual.

(d) *Robinow's method for cell outlines* (1936, *Protoplasma*, 27, 86)

Wash the surface of the object in water or saline. Half a minute in 20 % dilution of Frog Ringer is good for fresh-water sponges.

(1) Fix *in the dark* for 1-1½ min. (till the specimen is white) in

AgNO <sub>3</sub>	1.0 g.
OsO <sub>4</sub>	0.1 g.
Distilled water	100 c.c.

(2) Wash thoroughly twice with a large excess of distilled water.

(3) Transfer to daylight or strong artificial light and develop in 5 % hydroquinone.

(4) Before the specimen is too dark wash well with distilled water. Transfer to 50 or 70 % alcohol. Counterstain if desired. Dehydrate, clear and mount.

### WHOLE MOUNTS: MOUNTING

(a) *Large objects.* Support the cover-slip with two strips of celluloid, Fig. 3 (a). Use plenty of balsam so that there is an

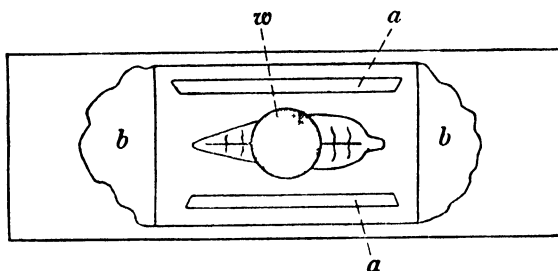

Fig. 3

excess (b) at the two ends of the cover-slip. On drying this is partly sucked in. Add more balsam at the ends during drying if necessary. When quite dry the excess balsam is easily removed with a safety razor blade. A weight of about 20 g. (w) on the cover-slip helps to flatten the object.

(b) *Small objects.* (i) Arrange these as desired face downwards in a drop of rather thick balsam *on the cover-slip*. Set to dry, covering with a slightly raised watch-glass to protect from

dust. When quite dry place a drop of thin balsam on the slide and lower gently on to the cover-slip.

(ii) Objects dealt with by the pyroxylin tube method (see above) can be transferred to a drop of thick celloidin in clove oil on a cover-slip, and suitably arranged. The whole is now hardened by exposure to  $\text{CHCl}_3$  vapour (see below: 'Celloidin sections', p. 33), after which it may be transferred to xylene and mounted, or taken back to equal parts of  $\text{CHCl}_3$  and absolute alcohol and then to 90 % alcohol, etc., for staining.

---

## PREPARATION OF FROZEN SECTIONS

In certain histological methods it is desirable that the object remain in an aqueous medium. *This is particularly necessary where fats must be preserved unaltered.* In such cases the preparation of frozen sections of material embedded in gelatine or gum-arabic solutions is necessary. The following techniques are recommended (see Baker, J. R. (1944), *Quart. J. Micr. Sci.* **85**, 1, for full descriptions).

### EMBEDDING AND SECTIONING

After fixation with Baker's formaldehyde-calcium wash the fixed material for 4 hr. in running water. For treatment after other fixatives see Carleton (1938).

Soak 25 g. gelatine in 100 c.c. of 0.25 % aqueous cresol (preservative) for 1 hr. Then warm till all is dissolved. Strain through muslin.

- (1) Soak the specimen in the gelatine solution at 37° C. for 24 hr.
- (2) Gel (preferably in a refrigerator) and cut out the block to shape.
- (3) Harden block in Baker's formaldehyde-Cd-Ca fluid for 24 hr.
- (4) Wash in running water for 4 hr.
- (5) Section at 15  $\mu$ . For details of the freezing microtome see Carleton (1938).

### TRANSFERENCE OF SECTIONS TO SLIDES

Dilute the above gelatine solution ten times, to 2.5 g. gelatine per 100 c.c. of 0.25 % aqueous cresol.

- (1) Warm this solution in a paraffin oven. Immerse clean slides in it, and let these warm up.
- (2) Remove slides. Wipe the back. Prop against a wall to dry, gelatine surface inwards.
- (3) Immerse a dry slide in distilled water together with the section. Withdraw it, holding section in place with a pin.
- (4) Dry round the section and the back of the slide.
- (5) As soon as the slide is dry expose it to the vapour of formalin (40 % HCHO).
- (6) Transfer slide to filtered formaldehyde-Cd-Ca fluid.

#### STAINING FROZEN SECTIONS: LIPOID STAINS

Frozen sections may be stained in the usual aqueous stains.

*Lipoid stains: Sudan black and Sudan IV (Scharlach R).* The use of these dyes to stain fatty substances in cells is strongly recommended. The dye Nile blue should not be used for this purpose. Its action is complex, and the old suggestion that with it a red colour indicated neutral fat whilst a blue colour indicated fatty acid is certainly false (Lison, 1936). The Sudan dyes, on the other hand, specifically dissolve in lipoids. Both Sudan black and the red Sudan IV are taken up by triglycerides, but the former has the greater affinity for other lipoids.

The same method applies to either dye. Make a saturated solution of Sudan black in 70 % alcohol. Saturation is essential. There must be excess dye, and several days must be allowed for complete solution. Filter the solution the day it is used.

- (1) Remove the slide from formaldehyde-Cd-Ca. Wash it for 3 min. in running water.
  - (2) Transfer it fairly quickly, via 50 and 70 % alcohol, to Sudan solution for 7 min. Let the slide rest obliquely with the section downwards to avoid collecting a precipitate.
  - (3) Pass through three successive lots of 50 % alcohol (30 sec. or less in each).
  - (4) Rinse in distilled water.
  - (5) Counterstain in Mayer's Carmalum (or Mayer's Haemalum for Sudan IV).
  - (6) Wash in running water for 3 min.
  - (7) Mount in glycerol and seal (p. 21).
-

## PREPARATION OF SERIAL SECTIONS BY PARAFFIN

### CLEANING AND SOFTENING

See animals are free from grit before fixation. If possible, starve animals a day or so in order to clear the gut. Avoid dust reaching reagents and paraffin bath. Minute particles of grit in the wax block are a common cause of damage to serial sections. Decalcify in 3-5%  $\text{HNO}_3$  in 70% alcohol if necessary. Unless newly moulted or soft, embed Arthropods in celloidin (p. 33) before impregnation. Soften dense chitin in Diaphanol (*Microtomist's Vade-Mecum* 10th ed., p. 597).

### IMPREGNATION

#### (a) *Paraffin* \*

For small specimens (5 mm.) transfer from xylene, benzene, or cedar oil to paraffin (m.p. 52-60° C.) for 1-3 hr. in all, changing the paraffin once or twice. Transfer with the minimum of clearing agent. Take up the specimen on a warm section lifter. Tilt to drain slightly. Rapidly insert and withdraw lifter from wax. Delicate specimens in xylene or benzene should first be transferred to the same solvent warmed on top of the embedding oven and saturated with chips of paraffin.

Do not transfer very small objects from xylene, lest they evaporate. Large objects in cedar oil should be rinsed in xylene before transference to wax. Remember that cedar oil diffuses out of large objects in molten wax rather slowly. Any object may be transferred to wax from liquid paraffin.

For ordinary work (room temperature 15-20° C.) use wax of m.p. 52-54° C. Sections can be cut with it down to 6 $\mu$ . For thinner sections, down to 2 $\mu$ , use hard wax. There is rarely advantage in very thin sections. Hard wax helps to support brittle objects. For hard wax, paraffin (m.p. 60° C.) may be used. But the following mixture (Waterman, H. C. (1939), *Stain Tech.* 14, 55) is nearly as hard and has the advantage that the low melting-point (51.3° C.) permits use in the same oven as ordinary 52° C.

\* Steedman, H. F. (1947, *Quart. J. Micr. Sci.* 88, 123), describes a valuable new embedding medium, *ester wax*.

paraffin wax. This wax cuts excellently on the microtome, but care is needed in flattening the paraffin ribbon because the sections flatten only just below the melting-point.

Paraffin (56° C.)	80 parts	Spermaceti	3 parts
Stearic acid	16 parts	Ceresin	1 part

Melt, stir well and filter through cotton-wool.

Embed yolky material in soft wax (m.p. < 50° C.) for the minimum period needed to impregnate. Harden the block in ice water before cutting.

(b) *Peterfi's Celloidin-Paraffin*

Small and delicate structures may undergo distortion or rupture with ordinary paraffin embedding. They can be supported by first embedding in celloidin. The celloidin block can in turn be embedded in paraffin. A method of doing this is given on p. 35. Most of the advantages of double embedding can be achieved more quickly and easily by Peterfi's method of pre-impregnation with celloidin.

(i) *Normal method*

After dehydration in absolute alcohol proceed to

Methyl benzoate + 1% celloidin, 3-5 hr.

Run the solution to the bottom of the alcohol and let the specimens sink before removing the alcohol (i.e. proceed as in clearing with cedar oil).

↓  
Fresh methyl benzoate + 1% celloidin, 3-5 hr.

↓  
Further fresh methyl benzoate + 1% celloidin, 12-24 hr.  
Specimens may be stored in this if desired.

↓  
Benzene, 15 min.

↓  
Fresh benzene, 15 min.

↓  
Benzene at 30° C. (on top of oven) saturated with paraffin wax,  
15-30 min.

↓  
Paraffin as usual.

(ii) *For yolk-laden eggs and cells*

Dehydrate via 30, 50, 70 and 95 % alcohol ( $\frac{1}{2}$  hr. in each).

↓  
Methyl benzoate celloidin (as above), 1-2 hr.

↓  
Benzene, 10 min.

↓  
Soft wax (m.p. 45° C.),  $\frac{1}{2}$  hr.

↓  
Fresh soft wax,  $\frac{1}{2}$  hr.

*Or embed directly.*

## EMBEDDING

Embed in a deep watch-glass. This should be first smeared with glycerol to prevent the paraffin sticking to the glass after cooling. Orient the specimen with a hot needle. Mark the exact position of the main and transverse axes of the specimen by pushing a sharp chinagraph pencil into the edges of the cooling wax plate. Make additional marks to indicate the anterior end of the specimen (Fig. 4 *a*). To prevent crystallization of the wax cool the

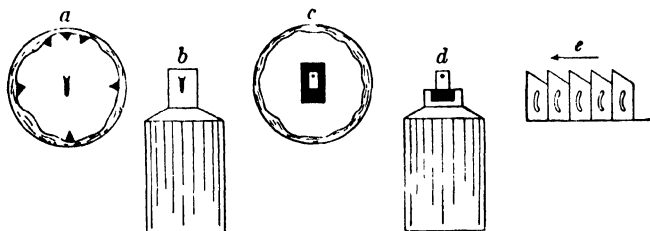

Fig. 4

watch-glass rapidly. Hold it on the surface of the water till a firm 'skin' forms on the wax, and then slide it vertically on edge into the water (not horizontally).

*Paraffin wax +  $\frac{1}{2}$  % ceresin* is less liable to crystallize than plain wax. It cuts as well or better.

Hard paraffin wax (60° C.) cooled in water at room temperature is liable to crack. Cool it in water at 25-30° C. (Wilson, D. P. (1932), *Philos. Trans. B*, 221, 231).

## ORIENTATION

Very small objects are more easily seen if stained with eosin during dehydration. Orient them in the hot wax with the aid of

a binocular microscope. It may be advantageous to arrange them in the wax on a small rectangular plate of *Ulva*, or of animal tissue, stained with borax carmine. Or, a window may be cut in a small rectangle of thin ash-free paper (e.g. decalcified cigarette paper) stained with chlorazol black. The little frame so made is then impregnated and laid in the hot wax in the embedding watch-glass. The object is then accurately orientated within the frame as in Fig. 4 *c*. The frame is cut away when the block is mounted (Fig. 4 *d*).

For orientating small specimens by means of celloidin blocks see section on 'Double embedding for small objects' (p. 35).

### CUTTING OF SECTIONS

Cut out a rectangular block of wax containing the object, determining first of all the plane in which the sections are to be cut. Seal the block on to the microtome block holder by melting the wax on the latter with a hot knife (Fig. 4 *b*). Trim the block so that the face which is to meet the microtome knife is parallel to the opposite face. This ensures that on sectioning the resulting ribbon will be straight. Trim the faces with single clean cuts of a sharp scalpel. Successive sections in the ribbon may break apart if the block faces are irregular.

Cut one of the lateral faces of the block obliquely so that sections in the ribbon will be shaped as in Fig. 4 *e*. This prevents confusion of direction when mounting the ribbon. In general, cut sections 8–10 $\mu$  thick.

If sections of a hard wax block fail to adhere as a ribbon, coat the block with softer wax (50–52° C.). Then cut away excess soft wax from the sides of the block. Avoid coating with soft wax unless necessary: it makes the ribbon more difficult to flatten.

Cut hard wax blocks at a room temperature at or just above 15° C. if possible.

Chill soft wax blocks (50° C. or less) in ice water before cutting.

Directions for rectifying faults which may arise during cutting are given in Carleton (1938).

### TRANSFERENCE OF SECTIONS TO SLIDES

Clean slides are essential if sections are to adhere. The best way to clean slides is by using the pastes sold for cleaning windows

(see these have no abrasive in them). Failing that use acid alcohol, or cleaning fluid if necessary.

Have ready some albumen adhesive. That is, a mixture of white of egg 50 c.c., glycerol 50 c.c., and sodium salicylate 1 g., or other preservative. Place a very small drop on the slide and rub on well with a clean finger. Cut the ribbon into lengths equal to about  $\frac{1}{2}$ — $\frac{2}{3}$  length of the slide, and with needles or paint brushes place the lengths—dull side upwards—in series so that the first section is in the top left-hand corner of the slide and the last section on the right-hand at the bottom. With a diamond, or with a glass pencil, number the slide in the bottom right-hand corner. If the slides be always numbered in that way it will be easy to determine on which side of the slide the sections are mounted, and the chance of their being rubbed off accidentally during subsequent phases of staining and dehydration will be greatly lessened. Gently flood the slides with cold distilled water and place on a hot plate at a temperature slightly below that of the melting-point of the wax employed. (Remember that sections from a hard wax block coated with soft wax are liable to separate if the soft wax melts.) The ribbon will extend on being warmed, and when the sections are flattened the water is run off. Curved ribbons may be gently straightened while extending on the warm plate. Dry the slides overnight in an upright position on the oven or at a temperature near 30° C. At low temperatures the sections may not stick on drying.

Sections of some materials are very liable to float off the slide, particularly if prolonged treatment in dilute acids happens to be necessary during staining. To ensure adhesion in such cases take the slides down to xylene, then through absolute alcohol to 90 % alcohol. Then dip in a 0.25 % solution of celloidin in a mixture of equal parts of alcohol and ether. Transfer to 70 % alcohol to harden the thin celloidin film. Proceed to stain as usual.

#### NUMBER OF SECTIONS PER SLIDE

Always use normal 3 × 1 in. slides unless for some special reason. Even with the smallest object do not try to get more than three rows of about twenty sections each. Leave an ample margin between the sections and the edge of the cover-slip, otherwise you cannot use an oil-immersion objective properly.

Remember, a specimen 8 mm. long will give 1000 sections of  $8\mu$ . Usually you will not have the time to examine each of a 1000 sections. Therefore do not cut the whole specimen and mount it on some twenty slides. Cut and mount just what is relevant to your work in hand.

---

### PREPARATION OF CELLOIDIN SECTIONS

Celloidin is a pure collodion (nitrocellulose). It is soluble in a mixture of equal parts of alcohol and ether, or in methyl benzoate, or in clove oil. Thick solutions in these solvents are 'hardened' or gelled when exposed to xylene or the vapour of chloroform. Celloidin embedding is useful for

- (1) hard or brittle objects;
- (2) the preparation of thick sections ( $100\mu$ );
- (3) the orientation of minute organisms by embedding a celloidin block in paraffin.

The disadvantages of celloidin embedding are

- (1) it is a very slow process;
- (2) it is hard to prepare serial sections (except in the case of thick sections);
- (3) celloidin sections wrinkle; exposure to ether vapour remedies this;
- (4) both fixation to the slide and staining are more difficult than with paraffin sections.

The general method is fully described in Carleton (1938, pp. 58 et seq.). Two special methods involving celloidin embedding are given below.

### THICK CELLOIDIN SECTIONS

The following method is one of many variants and is based on Dennell, R. (1940, *Sci. J. R. Coll. Sci.* 10, 83). Thick sections are of great value in microanatomy, and they are particularly suitable for organisms 1-2 cm. long where the anatomical relations can be much more clearly studied by cutting into a few slices about  $100\mu$  thick than with the more usual and more numerous sections of  $10\mu$ .

To prepare solutions of celloidin, wash the celloidin chips for several hours in running water, dry well on filter paper in the

warm, soften in absolute alcohol 12-24 hr., add an equal volume of ether, agitate at intervals for some days. Make 2%, 4% and 8% solutions.

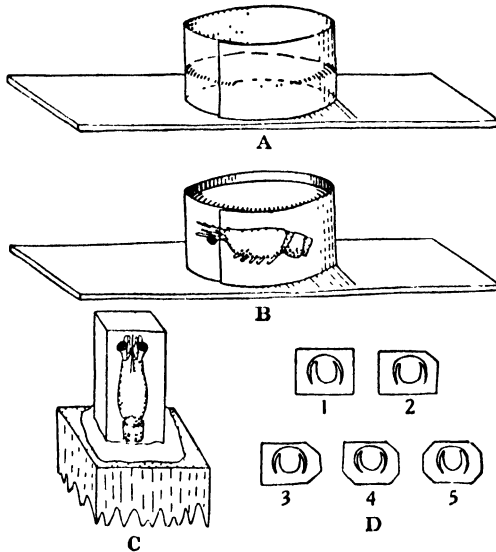

Fig. 5

The specimen is passed through

- (1) Absolute alcohol.
- (2) Equal parts of absolute alcohol and ether.
- (3) 2% celloidin in alcohol and ether (several days).
- (4) 4% celloidin in alcohol and ether (several days).
- (5) 8% celloidin in alcohol and ether (a week). Then:
- (6) Make a paper ring from a gummed label as in Fig. 5 A. Half fill with 8% celloidin.

(7) Harden by placing in a covered dish together with cotton-wool soaked in chloroform.

(8) When hard, thoroughly soften the surface with a faint trace of alcohol-ether, fill with 8% celloidin, insert the object and orientate. Bubbles may be burst by cautious touching with ether (Fig. 5 B).

(9) Harden overnight or longer in a covered dish by means of the vapour from a cotton-wool pad soaked in chloroform.

(10) Remove the block by slipping a razor blade under it.

(11) Clear in cedar-wood oil + a few drops of absolute alcohol and chloroform (several hours). Clear difficult material in

CHCl <sub>3</sub>	4 parts by weight	Alcohol	4 parts
Origanum oil	4 parts	Phenol	1 part
Cedar oil	4 parts	Na <sub>2</sub> SO <sub>4</sub> , anhydrous	1 part

(12) Trim block as in Fig. 5 C. Wipe off excess cedar oil, and then mount with a few drops of 8% celloidin on the holder of a Jung sledge microtome. Use chloroform vapour to harden the attachment of the block.

(13) Moisten the knife and block with cedar oil. Cut sections 100  $\mu$  thick. Transfer at once to cedar oil. Mark every five sections successively by clipping (see Fig. 5 D). Put each series of five in a separate dish. Stain and mount sections individually.

For staining, pass via xylene to a mixture of equal parts of absolute alcohol and chloroform (*not* to pure absolute alcohol), then to 90% alcohol, etc. Stain with Mallory or chlorazol black.

Clear from 90% alcohol via a mixture of equal parts of absolute alcohol and chloroform (avoid absolute alcohol alone). Thence pass to pure chloroform, to cedar oil and to balsam.

#### DOUBLE EMBEDDING FOR SMALL OBJECTS

D. P. Wilson's method (1933, *J. Roy. Micr. Soc.* 53, 220). Prepare a treacle-thick solution of celloidin in equal parts of alcohol and ether. Add an equal volume of clove oil; stir well.

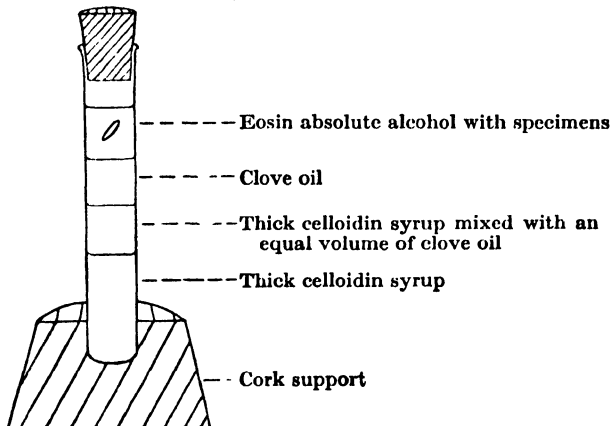

Fig. 6

Place in the warm, occasionally stirring till all smell of ether has vanished. Thin down with clove oil till the viscous residue is a little more fluid than treacle (at room temperature a 0.1 g. lead shot should sink 1 in. in a minute).

Stain specimens in eosin in absolute alcohol to render them visible. Place in a small upright closed glass tube as in Fig. 6. After a few days the specimens sink into the thick syrup. Then pipette off the solutions above it.

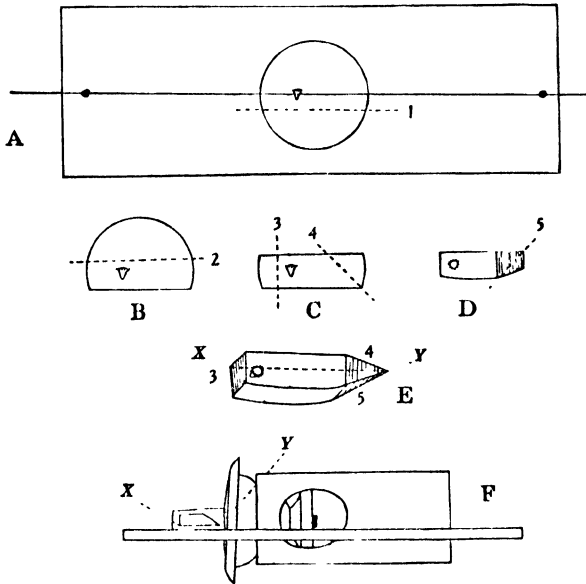

Fig. 7

Fix a ring (glass, cardboard or metal) about  $\frac{1}{2}$  in. diam.  $\times \frac{1}{16}$  in. high to a slide flooded with molten paraffin wax. Place the slide in a small Petri dish. Fill the ring with celloidin. Transfer the specimen to it and orientate under the microscope (Fig. 7 A). To harden, transfer Petri dish and slide to a larger dish with level bottom, together with a small beaker of chloroform; cover. If left overnight at 16–18° C. the mass will be hardened next morning. Fill Petri dishes with xylene, and after an hour or two transfer the celloidin mass to cedar oil.

Using a razor blade cut out a rectangular block of celloidin with a vertical surface parallel to the future cutting plane (Fig. 7 B, C). To indicate the position of the object in the block cut off edges

to a point at the opposite, bottom, right-hand end from the specimen in Fig. 7 C-E.

Embed in hard paraffin, trim this parallel to the embedded block, orientate (Fig. 7 F), and section.

Mount in the usual way but complete flattening of the celloidin by exposure of the drying slide to ether vapour. Dry very slowly to avoid crinkling of celloidin, and for a long time to ensure adhesion of sections.

---

## STAINING PARAFFIN SECTIONS

### PREPARATION FOR STAINING

Transfer slides of paraffin sections to xylene for 1-3 min. and then through the series:

Absolute alcohol	$\frac{1}{2}$ -1 min.
90 % alcohol	$\frac{1}{2}$ -1 min.
70 % alcohol	$\frac{1}{2}$ -1 min.
Distilled water	

to whatever stage is required for staining.

Only for very delicate work (e.g. Protozoa) is it necessary to pass thin sections or films through 50 or 30 % alcohols.

### OBJECT OF STAINING

The best stain depends on the object in view. One may stain to show cytological detail, to elucidate the anatomy of a small organism, to trace the distribution of particular tissue elements, such as elastic fibres, or to detect the presence of a specific chemical substance. The most important staining method is still *Heidenhain's Iron Haematoxylin*. *Before all other methods this must be practised till its correct use is automatic*. This stain is unsurpassed for photography and for the resolution of structure under critical illumination. It is the best stain for cytological detail. It can also be used by itself as a micro-anatomical stain where tissues are clearly differentiated, as in arthropods, and in more difficult cases by making it the basis of a polychrome stain such as Masson's *Ponceau-light green (Trichrome)* method.

Hansen's *Trioxhaematin* is a useful alternative to Iron Haematoxylin. It gives a highly selective staining of the nuclei

which is not more disturbed by subsequent treatment than is the case with Iron Haematoxylin. Cytoplasmic structures stain little, or, when the solution is fresh, not at all.

In general, for micro-anatomical work a slight modification of the original *Mallory's Triple stain* method is admirable, and practice in this is recommended. Various tissues are differentiated by their tint in a most striking manner. The method has the virtues of speed and simplicity. Provided all the operations are standardized, it is the easiest method by which a beginner may stain a long series of slides in precisely the same manner and to the same extent. The method suffers from certain defects. Mallory preparations are liable to fade—at best in a matter of years, at worst in a few months—though for most purposes, other than for demonstration specimens, they survive long enough. Fading can be postponed with suitable mounting media (see p. 48). Compared with some polychrome stains, Mallory is less precise: that is, the differentiation of tissues into those that will and those that will not take each component dye is not always sharp. A modification of Mallory known as Heidenhain's '*Azan*' method is more precise than the original and survives much better. It gives an exceedingly beautiful micro-anatomical stain. Its one disadvantage is the longer time it takes, and this is serious if the time available is short or liable to interruption.

Reference may also be made to Picro-Mallory (McFarlane, D. (1944), *Stain Tech.* 19, 29). This modification is as precise as the Azan method and is not so slow. But it is somewhat complicated and the use of acid fuchsin probably renders the coloration somewhat less fast than that by the Azan method. On the other hand, the picro-haematoxylin basis adds to the power of tissue differentiation. A good alternative polychromatic stain, based on Iron Haematoxylin, is obtained with various modifications of *Masson's Trichrome* method. *Mann's Methyl blue-eosin* is a useful polychromatic stain, particularly for sections of insects. It sharply distinguishes basophil and oxyphil substances. The method can be rapid, and since all the solutions employed in it are neutral it is suitable for use in conjunction with histochemical tests.

*Mayer's Haemalum*, with a counterstain, is a simple, quick and vigorous micro-anatomical stain. It is not necessary to make

every section 'all glorious within' for it to show what is wanted. *Mayer's Carmalum* is useful when a red nuclear counterstain is needed to contrast with blue, green or black cytoplasmic stains. *Chlorazol Black* stains chitin and cellulose, and is also a good nuclear and general tissue stain. It frequently gives marked metachromatic staining.

Methods for special tissue elements and for histochemistry may be sought in Carleton (1938) and Lison (1936). But because they are so generally useful the osmic (p. 55) and Sudan (p. 27) methods for fats are given. The section on 'Special methods' also includes methods for staining of Protozoa, which require some different techniques from those used for Metazoa.

Stains of different brands sometimes differ in their properties. Where necessary, therefore, in the following schedules, a brand is specified which has been found satisfactory. This does not imply that another brand cannot be used, though its use might possibly involve a revision of the schedule.

*Coloured light-filters* (e.g. Wratten filters) may greatly enhance visible contrast for some stains. For filter solutions, see Petersen, H. (1924), *Z. wiss. Mikr.* 41, 358.

#### HEIDENHAIN'S IRON HAEMATOXYLIN

##### *Solutions*

(a) Iron alum, ammonium ferric sulphate, 3% solution in water. This acts as mordant and, when diluted, as differentiator.

(b) 5% haematoxylin in 96% alcohol 10 parts, distilled water 90 parts.

(c) As counterstains one may use  
1% eosin in 90% alcohol or  $\frac{1}{2}$ % orange G in 90% alcohol.

Haematoxylin solution slowly 'ripens' by oxidation from the air. Ripening can be effected in a few hours and more uniformly if 0.2 g. sodium iodate is added for each 1 g. haematoxylin.

##### *Procedure*

(1) Bring the sections down through the alcohols and wash well in distilled water. They can be kept for some days in water in a covered vessel.

(2) Mordant in 3% iron alum for 30 min.—24 hr.

(3) Wash rapidly in distilled water.

(4) Stain in haematoxylin for 30 min.—24 hr. To the naked eye the whole preparation should be the colour of Indian ink.

(5) Wash rapidly in distilled water.

(6) Differentiate in 1½% iron alum. The mordant solution should not be used for this. Follow the progress of differentiation under the microscope. First the cytoplasmic background clears, particularly the connective tissue; then various cytoplasmic inclusions, various kinds of muscle and red blood cells, and finally chromatin of nuclei. Correct differentiation needs practice.

(7) Wash in distilled water; dehydrate.

(8) Counterstain (if needed) 1–5 min.; differentiate in 90% alcohol. Clear and mount.

After use the solution of haematoxylin usually becomes black owing to admixture with the iron alum, but this can be ignored and the same solution employed again and again.

### *Times*

After most fixatives mordant at room temperature for 1 hr. and stain for 1 hr. After Zenker give longer treatment. After chrome-osmium fixatives mordant and stain for 12 hr. each.

Both mordanting and staining have a high temperature coefficient. 10 min. suffices instead of 1 hr. at 50–60° C.

## HANSEN'S IRON TRIOXYHAEMATIN

### *Solutions*

(a) Iron alum (ammonium ferric sulphate)	10 g.
(NH <sub>4</sub> ) <sub>2</sub> SO <sub>4</sub>	1.4 g.
Distilled water	150 c.c.

Dissolve by gentle heating.

(b) Haematoxylin (Gurr)	1.6 g.
Distilled water	75 c.c.

Dissolve by heating.

Cool the solutions. Pour solution (b) into a porcelain evaporating dish. Add solution (a) to this (not vice versa), stirring constantly. Heat slowly, without stirring, just to boiling-point. Cool rapidly by floating the dish on cold water. The originally deep violet solution should then have become dark brown without any green sheen. Filter into a well-stoppered hard glass bottle. To prevent oxidation leave but little air space above the solution, which will

keep for 6-8 months. After use the solution may be decanted back into the bottle.

### Procedure

- (1) Bring the sections to water.
- (2) Stain progressively to the desired tint (1-10 min.) with trioxyhaematin.
- (3) Wash in tap water, 15-30 min.
- (4) Counterstain, etc.

A variety of counterstains may be used, e.g. aniline blue and orange G. For this one may pass from stage (3) above to stage (6) in the procedures for Heidenhain's Azan stain, or for Mallory's stain.

Freshly prepared trioxyhaematin gives a sharp black nuclear stain, the cytoplasm remaining almost colourless. Older solutions may stain cytoplasmic structures brown. This colour can be removed by differentiating in 2%  $H_2SO_4$ . Romeis recommends the initial addition of 2-4 c.c. of 1%  $H_2SO_4$  to each 8 c.c. of stain in order to ensure a pure nuclear stain, but this does not always seem necessary.

### MALLORY'S TRIPLE STAIN

#### Solutions

- (a) Preliminary mordant. Saturated  $HgCl_2$  in water + 5% acetic acid.
- (b) Acid fuchsin, 1% in distilled water.
- (c) Phosphomolybdic acid, 1% in distilled water.
- (d) Mallory's stain:

Aniline Blue W.S. (Gurr)	0.5 g.
Orange G	2 g.
Oxalic acid	2 g.
Distilled water	100 c.c.

'Aniline Blue' *sensu stricto* is a mixture of basic dyes soluble in alcohol but insoluble in water. It is unsuitable. 'Aniline Blue W.S.' (= water soluble) is a mixture of acid dyes obtained from this by sulphonation.

It is important to use Aniline Blue W.S. of a known and reliable brand, because the proportion of the component dyes

varies in different brands. Methyl blue, a specific constituent of Aniline Blue W.S., may be used in its stead.

### *Procedure*

- (1) Bring slides to water.
- (2) Mordant in  $\text{HgCl}_2$ -acetic acid, 10 min.
- (3) Rinse in distilled water.
- (4) Acid fuchsin, 15 sec.
- (5) Differentiate by washing in distilled water, 10 sec., or more as required.
- (6) Phosphomolybdic acid, 60 sec. (Avoid contact with metal forceps: protect these with collodion or paraffin.)
- (7) Wash with distilled water, 10 sec.
- (8) Mallory's stain, 75 sec. Drain and wipe the *back* of the slide.
- (9) Distilled water, 10 sec. Drain and wipe.
- (10) Differentiate Aniline Blue W.S. in 90 % alcohol, 10 sec., or more as required.
- (11) 1st absolute alcohol, 10 sec.
- (12) 2nd absolute alcohol, 10 sec.
- (13) Mount direct in Euparal, or via *pure* xylene or benzene, in good-quality balsam.

*The times given in (4)–(9) are suitable for nemertine and planarian material fixed in Susa. They vary considerably, however, with different tissues and different brands of stain, and for many organisms are considerably longer.*

Standardization of operations is important. When staining with acid fuchsin and when washing, move the slide obliquely backwards and forwards in the jar once a second.

For a single slide control differentiation under the microscope. When staining a series of slides, the first should be examined in xylene, and if the staining is imperfect bring it back via alcohol and tap water to wash out the stain; readjust the times, and repeat the staining process. It is easier to obtain standard results with a series of slides by differentiation for a constant time than by controlling the process in each slide individually under the microscope.

Removal of excessive staining with acid fuchsin can be hastened by substitution of tap water for distilled water at stage (5).

### *Principle of the method*

Acid fuchsin is very soluble in water, particularly if slightly alkaline as in tap water. It is fast in neutral alcohol. Aniline Blue W.S. rapidly dissolves in water and more slowly in 90 % alcohol. The phosphomolybdate intensifies the staining of the fuchsin in some elements and helps to decolorize the collagen. It increases the tendency for the collagen rather than other elements to stain with Aniline Blue W.S. The oxalic acid intensifies the Aniline Blue W.S. staining. In the mixture of acid dyes, orange G and Aniline Blue W.S., each excludes the other from tissues which it selectively stains.

Nuclei, red; muscle and various cytoplasmic constituents, red to orange; nervous system, lilac; collagen, dark blue; mucus, connective tissue and other hyaline substance, blue; 'chitin', red or blue according to its nature; yolk, yellow to orange.

### HEIDENHAIN'S AZAN STAIN

#### *Solutions*

(a) 0.1 % azocarmine G (Gurr) or GX in distilled water. Boil. When cold, filter through a soft filter paper. Add 1 c.c. glacial acetic acid per 100 c.c.

(b) Aniline, 1 c.c., 90 % alcohol, 1 litre.

(c) Glacial acetic acid, 1 c.c., 96 % alcohol, 100 c.c.

(d) 5 % phosphotungstic acid in distilled water, freshly prepared.

(e)	Aniline Blue W.S. (Gurr)	0.5 g.
	Orange G	2.0 g.
	Distilled water	100 c.c.

Add 8 c.c. glacial acetic acid. Boil. Filter when cold.

Dilute with twice the volume of distilled water.

Azocarmine G is rather insoluble and, when cold, solution (a) will become a partial suspension. This reverts to solution on warming. Romeis recommends a 0.25–1.0 % solution of the more soluble azocarmine B as an alternative.

#### *Procedure*

(1) Take the slides down to water.

(2) Stain in azocarmine 45–60 min. at 56–60° C. in a stoppered jar (30 min. suffices if stain is already warm).

(3) Wash in distilled water.

(4) Differentiate in aniline alcohol under the microscope. Only nuclei should remain pink, other parts greyish.

(5) Stop differentiation by washing off aniline in acetic alcohol,  $\frac{1}{2}$ –1 min. Slides may wait for a short time at this stage.

(6) Mordant connective tissue in 5% phosphotungstic acid 1–3 hr.

(7) Wash rapidly in distilled water.

(8) Stain in aniline blue-orange G-acetic mixture, 1–3 hr.

(9) Wash briefly (seconds) in water. Aniline Blue W.S. washes out very quickly indeed. To retain stain in fine fibres omit washing in water.

(10) Differentiate in 96% alcohol.

(11) Pass through absolute alcohol and xylene, mount in balsam. The method gives beautifully sharp and stable staining.

Chromatin of nuclei, red; erythrocytes and neuroglia, red; muscle, red to orange, according to fixative; mucus, blue; collagen and reticular connective tissue, sharp blue; cytoplasmic granules, etc., red, yellow or blue.

#### MASSON'S TRICHROME STAIN

The original method (see Carleton) employs Heidenhain's Iron Haematoxylin followed by differentiation with alcoholic picric acid. In the following rapid modification this is replaced by Hansen's stain, and following J. R. Baker (1942, *B.D.H. Standard Stains Catalogue*), Xylidene Ponceau replaces the original Ponceau-Acid Fuchsin mixture.

#### Solutions

(a) Hansen's Iron Trioxyaematin (see p. 40).

(b) Xylidene Ponceau:

Xylidene Ponceau (s.s.)	0.25 g.
1% aqueous acetic acid	100 c.c.

(c) Phosphomolybdic acid, 1% in water.

(d) Light green:

Light green (s.s.)	2 g.
2% aqueous acetic acid	100 c.c.

*Procedure*

- (1) Stain in Hansen's stain (about 3 min.).
- (2) Wash 15 min. in running tap water.
- (3) Stain in Xylidene Ponceau till rather darker than finally required (1-5 min.).
- (4) Rinse in distilled water.
- (5) Differentiate in phosphomolybdic acid, 4 min.
- (6) Rinse in distilled water.
- (7) Stain collagen in light green (about 2 min.), examining at intervals in distilled water.
- (8) Dehydrate rapidly as in Mallory. Mount in balsam.

Nuclei, black; collagen fibres and mucus, green; muscle, cytoplasm, epithelium, etc., shades of pink. The method gives a very clear picture of the distribution of collagen.

## MANN'S METHYL BLUE-EOSIN

*Solutions*

(a) 1 % aqueous methyl blue ( <i>not</i> methylene blue)	85 c.c.
1 % aqueous eosin	45 c.c.
Distilled water	100 c.c.

Add a few drops of formalin as preservative.

- (b) 70 % alcohol with one drop of saturated solution of orange G per c.c. (Dobell's differentiator).

*Procedure*

- (1) Bring slides down to distilled water.
- (2) Stain overnight in methyl blue-eosin.
- (3) Rinse well in distilled water (20-30 sec.).
- (4) Differentiate in the Dobell's dilute orange G.
- (5) Dehydrate rapidly in neutral absolute alcohol.
- (6) Mount in Euparal, or clear, and mount in balsam.

*For rapid work:* Stain 10-30 min., differentiate in tap water, dehydrate quickly and mount as above.

Though both are acid dyes, the methyl blue behaves as though it were basic, so that the method sharply distinguishes basophil from oxyphil elements. The method is also useful for studying the vascular and nervous systems. It is a particularly good micro-anatomical stain for sections of insects.

Nuclei, 'chitin', connective tissue and mucus cells, blue;

basophil cells and granules, blue; oxyphil cells and granules, red; muscle, shades of red; other tissue elements, shades of red, violet, and blue.

## MAYER'S HAEMALUM

*Solutions*

(a) In 1000 c.c. distilled water, dissolve

Haematoxylin	1 g.
Sodium <i>iodate</i>	0.2 g.
Potassium alum	50 g.

Shake frequently till solution is blue-violet (some hours).

<i>Add</i>	Chloral hydrate	50 g.
	Citric acid crystals	1 g.

Solution now turns red-violet.

Keep in a hard glass bottle.

(b) Counterstain: saturated solution of eosin in 90 % alcohol.

*Procedure*

- (1) Bring slides down to water.
- (2) Stain sections in the haemalum, controlling under microscope till nuclei are bright red (4-6 min.).
- (3) Wash thoroughly in tap water till blue (about 10 min.).
- (4) Pass through alcohols to 90 % alcohol.
- (5) Stain in eosin 2-5 min.
- (6) Differentiate in 90 % alcohol.
- (7) Absolute alcohol; xylene; balsam.

Mayer's Haemalum is a *progressive* self-differentiating stain. It has advantages over and may be used instead of the more usual Delafield's Haematoxylin.

Nuclei, blue; cytoplasm, pink.

## MAYER'S CARMALUM

*Solution*

In 200 c.c. of distilled water dissolve

Potassium alum	10 g.
Carminic acid	1 g. (expensive!)

Heat gently; cool; filter.

Then add

Salicylic acid	0.2 g.
or Formalin (40 % HCHO)	0.1 c.c.

*Procedure*

- (1) Bring sections down to water.
- (2) Stain in carmalum till nuclei bright red (about 15 min.).
- (3) Wash 2-3 min. in distilled water.
- (4) Pass through alcohols. Counterstain in transit if necessary.
- (5) Absolute alcohol; xylene; balsam.

Carmalum is a progressive stain. It stains nuclei bright red and is therefore a good nuclear counterstain when cytoplasmic structures are stained blue or black (e.g. after silver impregnation).

## CHLORAZOL BLACK E

See Cannon, H. G. (1941), *J. Roy. Micr. Soc.* 61, 88.

*Solution*

Chlorazol black E (biological quality) saturated solution in 70% alcohol.

*Procedure*

- (1) Bring sections to 70% alcohol.
- (2) Stain with chlora black, 15-30 min.
- (3) Dehydrate, clear, and mount as usual.

The stain is *progressive*. If overstained, differentiate with pyridine or dilute 'Milton'. The stain can also be used in water.

Nuclei, black; cytoplasm, etc., shades of grey; 'chitin', greenish black; glycogen, pink or red.

Chlorazol black is the chief member of an interesting series of dyes. It has a strong affinity for cellulose as well as for 'chitin', using that term in the zoological rather than the chemical sense. It is not yet clear whether it stains chitin itself or the sclero-protein associated with it. It normally stains metachromatically. It is a valuable stain for plant tissues (Darrow, M. D., 1940, *Stain Tech.* 15, 67). Its staining effects are markedly influenced by the solvent. The stain can be used in water. Conn uses a 1% aqueous solution for chromosomes of root-tips (1943, *Stain Tech.* 18, 189).

---

## PRESERVATION OF SECTIONS

## MOUNTING

In general it suffices after staining to clear sections in xylene and to mount in balsam. To prevent fading of some stains it is an advantage to avoid xylene and Canada balsam, unless known to be pure. One may mount in Euparal from alcohol, or one may proceed via benzene, to neutral Canada balsam in benzene, or to a proprietary resin in benzene or pure xylene. Benzene balsam dries rapidly and is less easy to handle than xylene balsam.

If slides must be taken rapidly out of absolute alcohol to prevent loss of stain, they may be passed to benzene via methyl benzoate. Benzene takes up even less water than xylene, and there is more danger from imperfect dehydration.

## FADING

Stained and mounted sections slowly fade if left in the light. Over decades, sections near the edge of a slide fade owing to slow oxidation by air. Fading in months or years is due chiefly to (1) imperfect removal of mordants, (2) impurity of clearing agent, (3) impurity of mounting medium and its solvent. Xylene and Canada balsam commonly become gradually acid, and in that state stains may fade in them, sometimes in a few months. Neutral balsam is much more satisfactory.

The causes of fading are not perfectly understood. An acid medium will attack basic dyes. But the worst offenders for fading are often acid dyes such as acid fuchsin, and such stains are in fact better preserved if pure balsam is saturated with salicylic acid (Langeron, 1934, p. 541). The most usual cause of fading is probably slow reduction of the dye. Both xylene and balsam are apt to accumulate reducing substances. An acid medium favours reduction. Hence come the advantages of avoiding xylene by using benzene, which is less reactive, of passing straight from alcohol to Euparal, and of exchanging Canada balsam for an artificial resin of more stable properties. Whatever the medium, it should be neutral if it is to hold both acid and basic dyes. It may be remembered that an alkaline medium is likely to favour oxidation just as an acid one favours reduction. Clearing and

mounting media may be tested for neutrality by means of litmus paper.

The standard investigation on fading remains: Heidenhain, M. (1908, *Z. wiss. Mikr.* 25, 397).

## DRAWING, RECONSTRUCTION, MICROMETRY

**Eyepiece micrometers**, when ruled in  $\frac{1}{2}$  mm. squares, permit a rapid and accurate drawing of a section to be made. Draw by preference on paper with squares lightly ruled in pencil. Drawings should only be made on graph paper if the printed lines are blue, otherwise these may appear when the drawing is photographed.

**Camera lucida.** This is a useful instrument for drawing the detail of a section. See the maker's instructions, or the description in Gage, S. H. (1936, *The Microscope*, New York: Comstock Publishing Co.). Practice is needed, particularly in adjusting the illumination of the paper relative to the image. A convex lens of 12–18 in. focal length, suitably placed between the eyepiece and the paper, diminishes eye strain.

**Direct projection** provides the simplest method of recording the detail of a section. In a darkened room tilt the microscope horizontally and stand it on a firm box about a foot above the table. Take out the mirror, and illumine the slide directly with a pointolite lamp. Accurate centring of the lamp and the condenser is essential. Place a right-angle projection prism over the eyepiece and throw the image on to a white sheet of paper on the table. If an arc lamp is used, heat rays should be cut out by an absorbing solution (p. 3). Do not expose a polychrome-stained section for a very long period to intense illumination; it may bleach.

The outline of the projected image may be drawn. Alternatively, the image may be exposed on bromide paper, giving a rapid record of the section in negative. Unless the lenses are apochromatic a colour filter must be used to cut out the ultra-violet; otherwise the photographic and visual images will not be at the same focus.

## GRAPHIC RECONSTRUCTION

For methods of reconstruction from serial sections, both for solid models and for diagrams, consult

Norman, J. R. (*J. Roy. Micr. Soc.* (1923), 37).

Pusey, H. K. (1939, *J. Roy. Micr. Soc.* 59, 232).

Lison, L. (1937, 'Les Méthodes de Reconstruction Graphique en Technique Microscopique', *Act. Sci. Industr.* no. 553. Paris: Hermann et Cie).

Most methods of reconstruction are laborious, but simple graphic methods such as those below well repay the labour. Do not embark upon reconstruction unless you have a perfect series of sections, mounted without distortion. One may ensure cutting the paraffin block exactly to shape by the use of a simple instrument devised by D. P. Wilson (1933, *J. Roy. Micr. Soc.* 53, 25).

*Method (1)*, for organs which extend considerably over a section, but do not involve many sections in the series. Draw the first section by one of the above methods. Orientate the drawing to fit the image of the second section, and then draw the latter superimposed in a different colour. Continue in the same way with the succeeding sections.

*Method (2)*, for organs extending over a very large number of sections. In this case it is an advantage to make the reconstructed diagram in a plane at right angles to that of the individual sections. Thus a horizontal plan may be made of the nervous system of an annelid worm from transverse sections.

Observe the first section with a squared eyepiece micrometer. Turn the latter till its centre line runs through some axis, such as the dorso-ventral, that can be clearly recognized in each section. With a bilaterally symmetrical organism, the axis may be chosen to run through some central structure such as a median blood vessel, or it may be determined by placing the outline of the transverse section symmetrically about the centre line of the micrometer, as in Fig. 8 B. Measure the position of the organ concerned to right or left of the axis.

Take a piece of squared paper and mark on it a vertical axis. Choose lines parallel with this to correspond with those in the eyepiece. Starting with the first section mark off the distance of the organ from the axis along one of the transverse lines of the

paper. Now move to the next section and note the new distance of the organ right or left of the chosen axis. Mark this new distance along the next transverse line on the paper. Continue in this way for each section. The diagram so constructed shows by a succession of points the course of the organ right or left of the axis throughout the series of sections (Fig. 8 C').

The vertical and transverse scales on the paper must be chosen to correspond. Thus if 1 cm. on the paper corresponds to  $20\mu$  right or left of the axis, and if each section is  $10\mu$  thick, the transverse lines in the diagram must be chosen  $\frac{1}{2}$  cm. apart. It may be unnecessary to record the position of an elongated organ in every successive section except at critical points. Where reconstruction of several objects in each section is desired (e.g. coiled ducts), it is advisable to use different colours for each object so that overlapping can be easily traced.

The method just described can be applied to specimens possessing a straight axis that can be represented in the reconstruction by a straight line. But sometimes there is no obvious axis, or only one which is curved in the plane of the reconstruction. In such cases a straight axis may be supplied externally by embedding the specimen alongside a flat plate of stained tissue or elder pith. Sections are then cut at right angles to this plate, and its face as seen in each section provides a base to which the position of organs can be referred (Fig. 8 D, E). Alternatively, one may use the sides of an accurately cut paraffin block as a reference frame. Pusey carefully paints round the outline of the paraffin ribbons, when dry on the slide, with a mixture of

Egg albumen	3 parts
Indian ink	6 parts
Saturated aqueous bile salts	1 part

The paint is thoroughly dried before passing the slide to xylene. The sides of each section are thus clearly defined.

In the case of a bilaterally symmetrical organism such as an arthropod, where the axis is often curved dorsally or ventrally, a reconstruction in the sagittal plane can be made from transverse sections in the following way also. The most nearly transverse section of the series is first selected: sections near the head and tail are likely to be inclined owing to curvature of the specimen

(Fig. 8 F). The distance between the dorsal and ventral surfaces of the section along its mid-line is measured with the micrometer eyepiece (Fig. 8 G). A line representing this distance on an appropriate scale is now marked off horizontally on a piece of

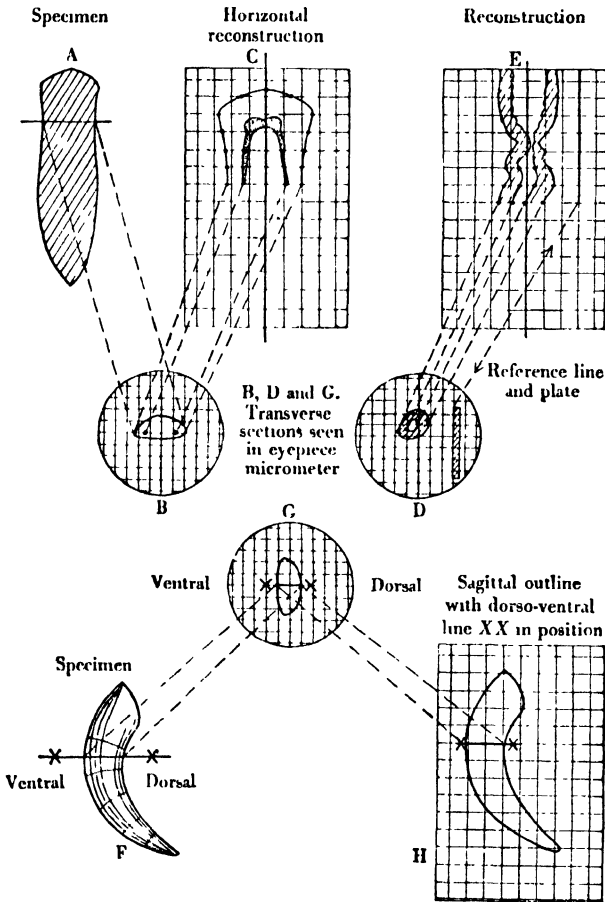

Fig. 8

squared paper. A sagittal outline of the specimen is then drawn on the same scale and is so orientated that the line occupies the exact position from which the section was cut (Fig. 8 H). The position of organs in this and each other section can now be referred to their distance from the dorsal or ventral surface, and can be plotted accordingly in the outline. A sagittal outline can

often be conveniently made by a drawing on tracing paper from the sagittal section of another precisely similar organism. The tracing may then be adjusted to fit the limits of the transverse section as marked on the squared paper.

It will be seen that the above methods may be combined with direct projection or with the use of the camera lucida. The reconstruction figure is then orientated to the image of the section and the position of the organ marked directly on the paper.

*For thick sections*, graphic reconstructions may be made by the above methods. A series of optical sections must, however, be recorded at successive depths in each section. See also Dennell, R. (1940, *Sci. J. R. Coll. Sci.* 10, 88).

#### MICROMETRY

Always record the actual size of objects observed under the microscope. Calibrate eyepiece micrometers for the lens systems of your microscope. For low powers, a ruled slide on the microscope stage is convenient. For high powers, a simple and accurate method is to observe the rulings on a replica diffraction grating, such as those supplied by Messrs Adam Hilger. For use with an oil-immersion lens, cover the grating with a dry thin cover-slip which may be held down at the edges with a little marine glue. Oil may then safely be placed between the objective and the cover-slip. The cover-slip must be in direct contact with the grating or there will be an appreciable error in measurement.

## Part II

## SPECIAL METHODS

## NERVOUS SYSTEM

**Mallory** shows general distribution of nervous material. Reisinger, E. (1925, *Z. wiss. Biol. Abt. A* (Morph. and Ökol.), 5, 119) gives a method of staining the nervous system of flatworms intra-vitam with alizarin.

The toluidin-blue method for Nissl granules will be found in Carleton (1938, p. 243).

**Silver impregnation** and other methods for detailed study of the nervous system will be found in Carleton (1938).

**Intra-vitam methylene blue** staining gives a superb picture of individual nerve cells. Most methods are very capricious. P. G. Unna's method (1916, *Arch. mikr. Anat.* 87, 96) as modified by MacConnell, C. H. (1932, *Quart. J. Micr. Sci.* 75, 495), is, however, very satisfactory for a great variety of animals.

*Preparation of stain.* To 100 c.c. of 0.5 % methylene blue solution in distilled water add three drops of 24 % HCl. Mix thoroughly and filter. To 10 c.c. of the filtrate add 2 c.c. of a 12 % Rongalit\* solution in distilled water. This mixture is now placed in a beaker and gently warmed over a small flame. Never allow it to come to the boiling-point. While being warmed observe it carefully and stir constantly. Eventually, the deep blue colour of the solution begins to change slowly to a deep, dirty green. At this point remove the solution from the flame, and continue stirring. In a few minutes it becomes almost clear in colour and contains a yellowish precipitate. Set the solution aside to cool and then filter into a dropping bottle. Allow to stand from 24 to 36 hr. before use. This solution is good for 8 or 10 days.

*Method.* Place animal or living tissue in about 25 c.c. of water, and add 1-2 c.c. of stain. The water first goes light milky blue, gradually becoming dark blue. Staining time varies with different animals, from a few seconds to 2 hr., and also varies with age of

the solution and quality of methylene blue. Nerve cells may be very small, and even when numerous, practice is needed to detect them under a low power, particularly in the nerve net of *Hydra*. A purple quality of colour distinguishes them from other objects. Practise on green *Hydra*, or palps of *Nereis*. Observe on slide under a cover-slip or in a cellophane compressorium (p. 3).

*Fixation* of methylene blue; see Addenda, p. 75.

---

## CYTOPLASMIC INCLUSIONS

For the study of Golgi bodies, mitochondria, etc., see the article in the *Microtometist's Vade-Mecum*, 10th ed., chap. 30.

The valuable techniques described by Baker, J. R. (1944, *Quart. J. Micr. Sci.* 85, 1) may be followed. Note the methods given under these references for the use of Janus Green, Neutral Red and other *Intra-vitam Dyes*.

---

## SPECIFIC CONSTITUENTS

For methods, other than those given below, refer to Lison (1936).

**Chitin.** The staining reactions are complex; see Yonge, C. M. (1937, *Proc. Zool. Soc. Lond.* 107, 499). For a discussion of its chemical properties see Pryor, M. G. M. (1940, *Proc. Roy. Soc. B*, 128, 393). Chlorazol black, basic fuchsin, or Mallory give good general staining but are not specific for chitin.

**Collagen** connective tissue is clearly differentiated from most tissues by the polychrome methods on pp. 41-45. They do not, however, serve to distinguish it entirely from mucin. Van Gieson (Carleton, 1938, p. 124) may be used as an alternative.

**Mucin** can be distinguished from collagen and all other tissue components by specific stains such as *mucihaematin* (Carleton, 1938, p. 174).

**Elastic fibres:** use orcein (Carleton, 1938, p. 125).

**Glycogen:** use Best's carmine (Carleton, 1938, p. 171).

**Fat.** (1) *Osmication.* Fix in Flemming-without-acetic for 24-48 hr. Dehydrate fairly rapidly; clear in cedar oil; embed in paraffin and section. Only fats containing unsaturated fat (they usually do so) will stain black; and since, moreover, other reducing substances will also blacken, the method is not precise.

Osmicated fat is decidedly soluble in xylene, though insoluble in cedar oil. Therefore avoid the former. Better still mount in Apáthy's syrup direct from water.

(2) *The Sudan method.* This is a precise direct stain for fat in cells. See above under 'Staining frozen sections' (p. 27). Fix in Baker's Formaldehyde-Calcium (p. 12).

**Feulgen's** reaction for Nucleoproteins.

*Solutions.* (a) Normal HCl (8.25 % of concentrated HCl solution).

(b) Dissolve 1.0 g. *basic fuchsin* in 200 c.c. of boiling distilled water. Stir well. Let the mixture cool to 50° C. Filter. Add 20 c.c. of normal HCl. When cooled to about 25° C. put in 1 g. of anhydrous sodium bisulphite. The solution loses the pink colour after several hours, and after 24 hr. is ready. This reduced basic fuchsin remains reliable for a fortnight. Keep in a stoppered bottle in the dark.

(c) Make a washing solution of

10 % Sodium bisulphite	10 c.c.
Normal HCl	10 c.c.
Water	200 c.c.

Prepare this fresh

*Procedure.* Fix in Schaudinn or in  $\text{HgCl}_2$  saturated solution + 2 % acetic acid. Bring paraffin sections or fixed protozoan films down to water. Transfer:

(1) To normal HCl 1 min. and then to normal HCl at 60° C. 5 min. (or up to 15 min.).

(2) To the reduced basic fuchsin for 1½–2½ hr.

(3) Wash thoroughly in three changes of the HCl-bisulphite washing solution.

(4) Wash well in water (30 min.), counterstain with light green (0.25 %), dehydrate, clear and mount.

Place a control preparation straight in the reduced basic fuchsin without stage (1) and pass both this and the test object through stages (3) and (4) together. In the test object the preliminary acid hydrolysis exposes an aldehyde group in nucleic acid which forms a violet condensation product with the fuchsin-sulphurous acid compound. The optimum duration of the hydrolysis varies with the organism and with the fixative. The

above times are correct for films of *Paramecium* fixed in Schaudinn.

*Do not treat the specimens with iodine after fixation* before Feulgen's tests.

**Enzyme distribution.** Glick, D. (1944, *Histochemistry, Ann. Rev. Biochem.* 13, 705).

Phosphatase: see Gomori, G. (1939, *Proc. Soc. Exp. Biol., N.Y.*, 42, 23), and see Addenda, p. 76.

## SPECIAL METHODS FOR PROTOZOA, ETC.

Thorough examination of living specimens is even more important in Protozoa than in Metazoa.

Transfer from sterile cultures by sterile pipettes or wire loops. Wire from electric radiator units is suitable for such loops and is cheap.

### Temporary mounts

(1) *For nuclei.* Add to a drop of culture a drop of a 1% solution of methyl green in 1% acetic acid. This fixes and stains nuclei green. The preparation will not stand dehydration.

(2) *For cilia and flagella* (Noland's method).

*Solution:*

Phenol, saturated solution in distilled water	80 c.c.
Formalin (40% HCHO)	20 c.c.
Glycerol	4 c.c.
Gentian violet	20 mg.

Moisten the dye with a little water before adding the other ingredients. See that the phenol solution does not contain phenol in suspension.

Add to a drop of culture a drop of this combined fixative and stain. Cilia and flagella stain clearly. Recommended for studying cirri of Ciliata.

### Fixatives

(1) *Schaudinn:*

Saturated HgCl <sub>2</sub> in distilled water	100 c.c.
Absolute alcohol	50 c.c.
Acetic acid, glacial	5 drops

(2) *Champy*:

1 % chromic acid	7 c.c.
3 % $K_2Cr_2O_7$	7 c.c.
2 % $OsO_4$	4 c.c.

(3) *Flemming with Reduced Acetic* (Meves):

0.5 % chromic acid in 1 % NaCl	15 c.c.
2 % $OsO_4$	4 c.c.
Acetic acid, glacial	2-3 drops

(4) *Osmic oxide* ( $OsO_4$ ):

As direct fixative or as vapour 2 %

Exposure to vapour may be effected by inverting a cover-slip carrying the specimen over an open osmic oxide bottle, the whole being enclosed in a covered tin or jar.

**Fixation of films on cover-slips**

Concentrate cultures if necessary by centrifuging.

(1) *With Schaudinn*. Clean cover-slips well in acid alcohol and 90 % alcohol. Dry between clean filter paper. Smear lightly with albumen. Drop a little rich culture on to a smeared cover-slip. Partly dry in air till tacky. Fix by dropping the cover-slip face downwards on to cold or warm Schaudinn in solid watch-glasses (with covers). Leave it in fixative, 5 min. Then reverse it and leave 10-15 min. more. Pick out the cover-slip and wash it in 50 % alcohol, 70 %, and 70 % with iodine, but *not* the latter before Feulgen's test. Place the cover-slip in 90 % alcohol in a corked tube for at least 48 hr. to harden the film.

Stain by borax carmine, or by Dobell's Iron Haematoxylin, or by Feulgen.

Clear from absolute alcohol, via a mixture of  $\frac{1}{2}$  absolute alcohol +  $\frac{1}{2}$  xylene to xylene.

(2) *With Champy*. Treat films as above. Fix for 15 min.

Wash 24 hr. in running water.

Harden in 90 % alcohol as above.

(3) *With osmic vapour* (dry films). Recommended for small flagellates, etc.

Smear a drop of culture on a cover-slip.

If the culture is watery, first smear cover-slip with albumen.

Dry by waving in air till tacky.

Expose to osmic vapour for 30 sec.

Transfer direct to absolute alcohol, 3-4 min.

Dry.

Stain with Giemsa, or Iron Haematoxylin or with crystal violet for flagella.

### Fixation of individual Protozoa

For large individuals, e.g. *Stentor*:

Fix in a film on a cover-slip by osmic vapour, 30 sec.

Post-fix with Schaudinn, 15 min.

Wash in alcoholic iodine.

Stain by Dobell's Iron Haematoxylin, or by other methods.

### Fixation in bulk for whole mounts and sections

Stir well (Amoebae then extend their pseudopodia).

Gently centrifuge to give a deposit about 1 mm. thick: suck off supernatant fluid. Pour on boiling Schaudinn *or* cold strong Flemming. Allow to settle. Centrifuge. Remove supernatant Schaudinn and replace by 50% alcohol. Centrifuge. Then proceed:

(a) *For whole mounts.* Place a drop of the sediment on a slide smeared with albumen. Cover with 70%, and then with 90%, alcohol (to coagulate the albumen). Wash with alcoholic iodine. Stain as required. See section concerning mounting of small objects (p. 25).

(b) *For serial sections.* Remove supernatant 50% alcohol from centrifuge tube. Add 70% alcohol.

Repeat centrifuging through the following:

70% alcohol + iodine.

90% alcohol.

Absolute alcohol (twice).

Pour into a clean dry centrifuge tube.

Centrifuge and transfer to xylene. Centrifuge and then place the tube in a beaker of water at 65-70° C. Rapidly suck off supernatant xylene and add molten hard paraffin wax. Place the whole in the paraffin oven for 15 min. Rapidly centrifuge and change wax. Leave in the oven, 15 min. Again centrifuge and change wax.

After a further 15 min., centrifuge and dip a looped wire into top of the melted wax (Fig. 9).

Transfer the tube to cold water to solidify wax (see Fig. 9). When quite cold, dip tube briefly into hot water again to loosen wax. Pull out the block at once by means of the wire. Trim the block, and cut sections at  $4\mu$ .

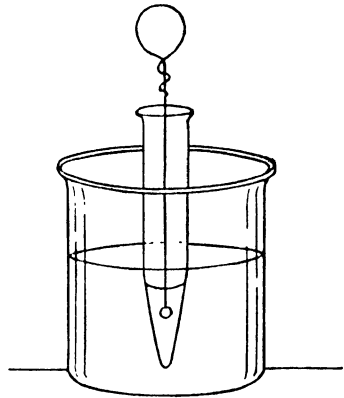

Fig. 9

### Staining Protozoa

#### (1) *Alcoholic Iron Haematoxylin.*

(Dobell, C. (1914), *Arch. Protistenk.* 34, 140)

Wash with 70 % alcohol.

Mordant 10 min. in 1 % solution of iron alum in 70 % alcohol.

Wash in 70 % alcohol.

Leave 10 min. in 1 % solution haematin in 70 % alcohol.

Wash in 70 % alcohol.

Put under microscope and differentiate with acid 70 % alcohol or the alum solution.

Pass to 90 % alcohol, and then to absolute alcohol.

Clear with oil of cloves or cedar oil (dehydration is harder with xylene).

#### (2) *Iron Haematoxylin for flagella and basal granules.*

Bring down to water.

To 1 % aqueous iron alum, 18–24 hr. Rinse in distilled water.

To 0.5 % aqueous haematoxylin, 24 hr.

Wash in water.

Differentiate in 1 % iron alum as usual.

#### (3) *Giemsa.*

A mixture of methylene blue and eosin. Buy it ready made.

For staining use 1 drop of stock solution per 1 c.c. of distilled water.

Stain for 1 hr. If stain too red wash with 0.02 % NaOH. If too blue, wash with 0.1 % acetic acid.

Buffering has considerable influence on staining with methylene blue and eosin solutions.

(4) *Crystal violet for Flagella.*

Fix a film with osmic vapour.

Without transference to alcohol add a drop of 0.005 % crystal violet.

Evaporate to dryness at 22–24° C. for 18–24 hr. Add clove oil rapidly to prevent rehydration and to differentiate while under the microscope.

Remove the oil with xylene and mount in balsam.

(5) *Feulgen.*

See under Special methods (p. 56).

Use hardened films on cover-slips.

**Methods for Ciliate Fibrillar systems**

For references see v. Gelci, J. (1934), *Z. wiss. Mikr.* 51, 103; v. Horváth, J. (1938), *Z. wiss. Mikr.* 55, 113; and the general article by Taylor, C. V. (1941), in *Protozoa in Biological Research*, ed. by G. N. Calkins and F. M. Summers. New York: Columbia Univ. Press.

*Dry method*

*Bresslau's Aniline Blue method for lattice and cilia* (Bresslau, E. (1921), *Arch. Protistenk.* 43, 467).

Place two drops of culture on a clean slide.

Add one drop of 3 % Aniline Blue W.S.

Mix and spread into a film.

Dry rapidly. Mount direct in balsam under a cover-slip.

*Wet method*

*Horváth's Formol-Silver method.* For ciliate fibrillar systems, cilia and trichocysts, and also flagellate pellicular systems (e.g. *Euglena*).

(1) Concentrate from a rich culture by gentle centrifuging. Decant supernatant fluid and suspend animals in a few c.c. tap water.

(2) Into 1 c.c. of formalin (40 % HCHO) squirt 1–4 c.c. of the culture: mix well.

(3) After a few seconds to 1 min., centrifuge and decant (do not wash). Add 1 % (or stronger) AgNO<sub>3</sub>.

(4) After 3–4 min., centrifuge and decant as much as possible. Add 2–3 c.c. 1 % NaOH.

(5) Shake continually for 2 min.: centrifuge.

(6) Wash and centrifuge first in distilled water and then in 30, 50 and 70 % alcohol.

(7) Then add a few drops 90 % alcohol and pour into a tube with a little glycerol-alcohol (80 % alcohol + equal volume of glycerol).

(8) Mount in glycerol alcohol.

The result varies with the species and the condition of the culture.

The longer the reagents act (especially the formalin), the greater the deposition of silver.

The greater the proportion of culture to formalin, the more the deeper structures (neuronemes, endoplasmic boundaries, contractile vacuoles, etc.) take up the silver.

The greater the proportion of formalin to culture, the greater the prominence of the lattice.

The above method is suitable for *Paramecium*.

For *Euplotes*, fix 1 min. as above, but in place of formalin use equal volumes of culture fluid and of a mixture of formalin (40 % HCHO) (1 part) and Bouin (1 part). Then proceed as above.

### Special methods for plant tissues

See *Microtomist's Vade-Mecum*, 10th ed., p. 620.

### Special methods for bacteria

See Mackie, T. J. & McCartney, J. E. (1940), *An Introduction to Practical Bacteriology*, 2nd ed. Edinburgh: Livingstone. Or Eyre, J. W. II. (1930), *Bacteriological Technique*. London: Baillière, Tindall and Cox. A synopsis of some of the more important methods of staining bacteria is given in the booklet *B.D.H. Standard Stains specially prepared for Microscopical Work* (1942). London: B.D.H.

## Part III

### APPENDIX

---

#### CULTIVATION OF ORGANISMS

See Galtsoff, P. S. and others (1937), *Culture Methods for Invertebrate Animals*. Ithaca, New York: Comstock Publishing Co.

Pringsheim, E. G. (1946), *Pure Cultures of Algae*. Cambridge: University Press.

*Diatom cultures* for rearing marine larvae, see Gross, F. (1937), *J. Mar. Biol. Assoc. U.K.* **21**, 753.

---

#### SALINE MEDIA

##### *For animal tissues*

**Sea water** (based on McClendon, J. F. (1916, *J. Biol. Chem.* **28**, 148) and Robertson, J. D. & Webb, D. A. (1939, *J. Exp. Biol.* **16**, 155).

Composition per litre of solution at 34.5‰, and 0.0025 M for bicarbonate. Cl = 19.1‰. Density = 1.0264 at 17.5° C. Freezing-point -1.88° C. Osmotic pressure approximately = 24 atm. at 15° C.

	g.
NaCl	23.427
KCl	0.729
CaCl <sub>2</sub> .6H <sub>2</sub> O	2.218 (1.124 anhyd.)
MgCl <sub>2</sub> .6H <sub>2</sub> O	10.702 (5.013 anhyd.)
Na <sub>2</sub> SO <sub>4</sub> .10H <sub>2</sub> O	8.967 (3.953 anhyd.)
NaHCO <sub>3</sub>	0.210
NaBr.2H <sub>2</sub> O	0.079

For minor constituents see Webb, D. A. (1937, *Sci. Proc. R. Dublin Soc.* **21**, 505).

Atlantic sea water varies from 35.0 to 35.5‰. North Sea sea water varies from 34.0 to 35.0‰. Inshore water is often seriously hypotonic from admixture with fresh water. For aquaria, the density should not be less than 1.0248 at 17.5° C. (= 32‰).

Aquarium water concentrates by evaporation and may be as high as 40‰ without harm to animals.

**Isotonic solutions** (approximate) for sea water at 34.6‰, calculated from cryoscopic data (from McClendon (1916) above, and from *Handbook of Chemistry and Physics*). Indirect calculation from conductance data (Nayes, A. A. & Falk, K. G. (1912), *J. Amer. Chem. Soc.* **34**, 454) would place  $\text{CaCl}_2$  and  $\text{MgCl}_2$  at about 0.39 *M*.

	g.p.l.
0.54 <i>M</i> NaCl	31.56
0.54 <i>M</i> KCl	40.26
0.36 <i>M</i> $\text{CaCl}_2 \cdot 6\text{H}_2\text{O}$	78.87 (39.95 anhyd.)
0.36 <i>M</i> $\text{MgCl}_2 \cdot 6\text{H}_2\text{O}$	73.20 (34.28 anhyd.)
0.44 <i>M</i> $\text{Na}_2\text{SO}_4 \cdot 10\text{H}_2\text{O}$	141.78 (62.50 anhyd.)
0.90 <i>M</i> $\text{MgSO}_4 \cdot 7\text{H}_2\text{O}$	221.84
0.54 <i>M</i> $\text{NaHCO}_3$	45.36
0.54 <i>M</i> $\text{NaBr} \cdot 2\text{H}_2\text{O}$	75.03
0.90 <i>M</i> for non-electrolytes	

*Sea water from isotonic solutions*

	c.c.
0.54 <i>M</i> NaCl	739.6
0.54 <i>M</i> KCl	18.05
0.36 <i>M</i> $\text{CaCl}_2$	28.0
0.36 <i>M</i> $\text{MgCl}_2$	145.7
0.44 <i>M</i> $\text{Na}_2\text{SO}_4$	63.0
0.54 <i>M</i> $\text{NaHCO}_3$	4.6
0.54 <i>M</i> NaBr*	1.05
	1000.0

\* For most purposes NaBr may be omitted or exchanged for equivalent NaCl.

**Natural blood** of the same species is often the best medium for tissues (e.g. *Helix*). It is, however, frequently contaminated with products from histolysis of amoebocytes and other cells. This is most marked in Crustacea where amoebocytic histolysis is a normal process engendering coagulation of the blood. Substances toxic to tissues may be liberated and the proportion of K in the blood may be considerably raised (this also tends to raise the estimated K content in blood analyses). Where difficulties of this kind are experienced, cool the animals thoroughly

before bleeding and centrifuge the cold blood in paraffined tubes.

The best way to bleed *Helix* is by *partial* drowning in a closed vessel. Water is absorbed and the available blood increased. Then slit the foot and leave the animals to drain in a funnel. Clear the blood by centrifuging.

**Marine Invertebrates.** Analyses of the body fluids of particular species vary rather considerably, partly owing to imperfection of analytical methods. But part of the variation is due to real individual differences of composition which the tissues of many species seem normally able to tolerate. The sources of the data on which the following tables are based are indicated by numbered references.

The tissues of many marine species can survive in isotonic sea water. Approximate similarity of ionic content between blood or coelomic fluid and sea water has been shown by reliable analysis in the genera (a) listed below. It cannot be assumed that this similarity necessarily obtains for all marine species of these groups. But even where the blood departs in composition from sea water the tissues of marine animals may survive in the latter. *Arenicola* blood contains excess K, but its tissues function normally in sea water (21). Old and unreliable data for the blood in *Cephalopoda* suggest a higher K and lower Mg than in sea water; but the giant nerve fibres of the mantle function normally in sea water (15).

#### *Suitable tissue medium*

	(a) Sea water	(b) 750 c.c. sea water + 5 c.c. 0.54 M KCl
Coelenterata	Most species	<i>Aurelia flavidula</i> (mesogloea) (9)
Polychaeta	<i>Aphrodite aculeata</i> (2)	<i>Arenicola claparedii</i> (2)
Mollusca	<i>Mytilus edulis</i> (8) and (1) <i>Aplysia limacina</i> (8) and (1)	<i>Pinna nobilis</i> (2) <i>Doris tuberculata</i> (8) and (1)
Xiphosura	—	<i>Limulus polyphemus</i> (9)
Crustacea	<i>Maia squinado</i> (2)	—
Echinodermata	<i>Astropecten aurantiacus</i> and related genera (2) <i>Echinus esculentus</i> and related genera (16) and (2) <i>Holothuria tubulosa</i> and related genera (2) and (7)	—
Tunicata	<i>Ciona intestinalis</i> and related genera (2)	—

In some genera the body fluid appears to resemble sea water except for an increase in K content of some 50 %. Examples of this are shown above in (b). The apparent K content may in some cases be raised through cytolysis of cells containing excess K. Thus the non-cellular fluid of *Aurelia* may be actually near to sea water. Some analyses<sup>(1)</sup> for *Maia* blood give a higher K than for sea water, but the heart survives and continues to beat in the latter.

There is a tendency in many genera to reduce Mg and SO<sub>4</sub> relative to sea water, with or without a rise in K and also in Ca, as shown in the table below. This is most evident in some Crustacea, where the blood may differ considerably from sea water, even though of about the same osmotic pressure. The blood of estuarine invertebrates in dilute sea water may differ from the external medium in osmotic pressure as well as ionic content.

	Sea water	<i>Sipunculus nudus</i> (2)	<i>Cancer pagurus</i> (16)	<i>Carcinus maenas</i> (20) (in sea water)	<i>Homarus vulgaris</i> (16)
0.54 M NaCl	745	830	816	858	897
0.44 M Na <sub>2</sub> SO <sub>4</sub>	63	32	53	35	18
0.54 M KCl	18	21	21	21	26
0.36 M CaCl <sub>2</sub>	28	29	37	35	40
0.36 M MgCl <sub>2</sub>	146	88	73	51	19

Little is yet known of the organic constituents of the body fluids of Invertebrata. There may be considerable excess of inorganic cations over anions owing to the combination of the former with organic compounds. This is especially the case with Ca. The protein content is often small, but in animals rich in haemocyanin (Crustacea and some Mollusca) it may reach high values:

		Protein %
Body fluid	<i>Echinus esculentus</i> (16)	0.03
Body fluid	<i>Aphrodite aculeata</i> (22)	Trace
Body fluid	<i>Sipunculus nudus</i> (22)	0.06
Blood	<i>Aplysia limacina</i> (22)	0.28
Blood	<i>Octopus vulgaris</i> (22)	10.6
Blood	<i>Homarus vulgaris</i> (16)	2.3
Blood	<i>Maia squinado</i> (22)	3.2
Blood	<i>Cancer pagurus</i> (16)	3.5
Blood	<i>Carcinus maenas</i> (20)	6.0

**Fresh-water and Terrestrial Invertebrates.** To attain the right pH it is convenient to add a phosphate buffer, e.g.  $M/100 \text{ Na}_2\text{HPO}_4$  (anhydrous = 1.42 g.p.l.). Bring this to the desired pH by adding 10% concentrated HCl drop by drop.

	Earth- worm	Leeches	<i>Helix</i>	<i>Limnaea</i> (8)	<i>Astacus</i> (18)	<i>Dytiscus</i> (5) and <i>Peri- plancta</i> (14)	<i>Apis</i> larva (10)
c.c. of 0.54 M NaCl	250	210	220	85	330	290	10
c.c. of 0.54 M KCl	5	8	7.5	5	10	5	(14)*
c.c. of 0.36 M $\text{CaCl}_2$	5	5	2.5	8	29	5	10
c.c. of 0.36 M $\text{MgCl}_2$	1	--	7	13	7	--	24
c.c. of 0.44 M $\text{Na}_2\text{SO}_4$	1	--	5.5	--	--	--	--
c.c. of 0.54 M $\text{NaHCO}_3$	--	3	3	3	--	--	--
c.c. of phosphate buffer	100	100	850	--	100	--	--
pH	7.4	7.4	8.4	--	7.5	7.2	6.4-7.0
$\text{H}_2\text{O}$	Add to 1 litre						

*Earthworm, leeches, Helix.* These are empirical solutions in which the tissues are found to survive. That for *Helix* is based on Hedon-Fleig's solution (see *Microtomist's Vade-Mecum*, 10th ed.).

*Insecta.* The figures for *Dytiscus* and *Periplancta* are based on solutions in which the tissues are known to survive well. *Dytiscus* and other insects can tolerate a considerably higher K content than this. In many cases the ionic picture is altogether different from that of other animals, there being a very high K and low Na, a condition resembling the intracellular ionic content of many animals. The figures based on an analysis of blood of *Apis* larva show this.

In *Apis* larva the figure (44)\* refers to c.c. of  $\text{K}_2\text{HPO}_4$  at 0.54 Normal for K (i.e. 94.0 g.p.l. anhydrous) and not to KCl. The blood also contains 6.6% protein and 1.8% free amino acids.

*Anodonta.* The blood is extremely dilute. The osmotic pressure is equivalent to 3% sea water in distilled water, but the ionic composition is unknown. The protein content is very low.

For colloid content of the blood of invertebrates, see (8), (12), (13) and (22).

### Vertebrata.

	<i>Scyllium canicula</i> (2)	Marine teleosts (23)	Fresh-water teleosts (23)	Amphibia (Ringer)	Mammal (Ringer- Locke)
c.c. of 0.54 M NaCl	500	430	174	210	270
c.c. of 0.54 M KCl	21	15	3.5	6	10
c.c. of 0.36 M $\text{CaCl}_2$	13	3	3	7.5	6
c.c. of 0.36 M $\text{MgCl}_2$	19	5	--	--	--
c.c. of 0.44 M $\text{Na}_2\text{SO}_4$	9	--	--	--	--
c.c. of 0.54 M $\text{NaHCO}_3$	--	--	--	4.5	4.5
c.c. of 0.90 M urea	438	--	--	--	--
pH	--	--	--	7.2	7.2
$\text{H}_2\text{O}$	Add to 1 litre				

In Knowlton's artificial solution for *Scyllium* the corresponding figures are: NaCl 440, KCl 14, CaCl<sub>2</sub> 12, MgCl<sub>2</sub> 15 c.c. of the above solutions. For rays one-quarter the Mg given for *Scyllium* may be used.

For colloids and other constituents of the blood of Vertebrata, see (3), (4) and (6).

#### SOURCES OF INFORMATION

The above animal media are calculated where possible from reliable analyses of the blood, allowance being made for any differences of salinity from that of British seas. Where analyses are not available the figures are taken from empirical media in which tissues are known to survive. The information is scattered, and in many cases the figures must be considered as provisional.

For American species, reference may also be made to the extensive data of Cole, W. H. (1940). *J. Gen. Physiol.* **23**, 575.

- (1) Bethe, A. and Berger, E. (1931). *Arch. ges. Physiol.* **227**, 571.
  - (2) Bialaszewicz, K. (1933). *Arch. Intern. Physiol.* **36**, 41.
  - (3) Hill, A. V. (1930). *Proc. Roy. Soc. B*, **106**, 477.
  - (4) Hill, A. V. and Kupalov, P. (1930). *Proc. Roy. Soc. B*, **106**, 445.
  - (5) Hobson, A. D. (1928). *J. Exp. Biol.* **5**, 385.
  - (6) Keys, A. and Hill, R. M. (1934). *J. Exp. Biol.* **11**, 28.
  - (7) Koizumi, T. (1932). *Sci. Rep. Tôhoku Univ.* **7**, 269.
  - (8) Krogh, A. (1939). *Osmotic Regulation in Animals and Man*. Cambridge University Press.
  - (9) Macallum, A. B. (1926). *Physiol. Rev.* **6**, 316.
  - (10) Maluf, N. S. R. (1939). *Quart. Rev. Biol.* **14**, 149.
  - (11) Mines, G. R. (1912). *J. Physiol.* **43**, 467.
  - (12) Picken, L. E. R. (1936). *J. Exp. Biol.* **13**, 309.
  - (13) Picken, L. E. R. (1937). *J. Exp. Biol.* **14**, 20.
  - (14) Pringle, J. W. S. (1938). *J. Exp. Biol.* **15**, 101.
  - (15) Pumphrey, R. J. and Young, J. Z. (1938). *J. Exp. Biol.* **15**, 543.
  - (16) Robertson, J. D. (1939). *J. Exp. Biol.* **16**, 387.
  - (17) Robertson, J. D. and Webb, D. A. (1939). *J. Exp. Biol.* **16**, 155.
  - (18) Schlatter, M. J. (1941). *J. Cell. Comp. Physiol.* **17**, 259.
  - (19) Webb, D. A. (1937). *Sci. Proc. Roy. Dublin Soc.* **21**, 505.
  - (20) Webb, D. A. (1940). *Proc. Roy. Soc. B*, **129**, 107.
  - (21) Wells, G. P. and Ledingham, C. (1940). *J. Exp. Biol.* **17**, 337.
  - (22) Winterstein, H. (1925). *Handb. vergl. Physiol.* Jena: Gustav Fischer.
  - (23) Young, J. Z. (1933). *Pubbl. Staz. zool. Napoli*, **12**, 425.
-

## PHYSICAL AND CHEMICAL DATA

See *Handbook of Chemistry and Physics* (various editions), ed. by C. D. Hodgman. Cleveland, Ohio, U.S.A.: Chemical Rubber Publishing Co.

*Humidity*

See Buxton, P. A. (1931). The measurement and control of atmospheric humidity in relation to entomological problems. *Bull. Ent. Res.* **22**, 431.

Ramsay, J. A. (1935). Methods of measuring the evaporation of water from animals. *J. Exp. Biol.* **12**, 355.

*Buffer solutions*

See Mansfield Clark, W. (various editions). *The Determination of Hydrogen Ions*. Baltimore: Williams and Wilkins.

For carrying solutions to an approximate *pH* the following may be added:

Substance	Approximate <i>pH</i> (in absence of strong buffers)
Concentrated HCl to 0.1%	2.0
KH phthalate	3.9
Na acetate + acetic acid in equal amounts	4.4-5.0
Na <sub>2</sub> H citrate	5.0
Na <sub>2</sub> HPO <sub>4</sub> and KH <sub>2</sub> PO <sub>4</sub> in equal amounts	6.6-7.0
NaHCO <sub>3</sub>	8.2-8.6
Borax	9.3
Na <sub>2</sub> CO <sub>3</sub> + NaHCO <sub>3</sub> in equal amounts	10.0-10.4
Na <sub>2</sub> CO <sub>3</sub>	11.0-12.0

## PREPARATION OF RECORDS

*Identification of organisms*

For British species see *Bibliography of Key Works for Identification of the British Flora and Fauna*. Association for the study of systematics in relation to general Biology, No. 1 (1942). London: Adlard and Son, Ltd.

*Nomenclature*

The rules for the correct naming of animals will be found in Hyman, L. H. (1940). *The Invertebrates*, chap. 2. New York: McGraw-Hill Book Co.

### Photography

*General technique.* See *Brit. J. Photogr. Alm.* London: Henry Greenwood Ltd.; and Allen, R. M. (1941). *Photomicrography*. London: Chapman and Hall.

*Exposure in artificial light.* An object illuminated by a 100 c.p. lamp 1 m. away requires very roughly 500 times the exposure it would need out of doors under a clear noon sky at the equinoxes.

*Exposure and stop.* For any particular lens, exposure is proportional to the square of the 'f' stop, i.e. *f* 16 needs twice, and *f* 22 needs four times, the exposure needed at *f* 11. The *f* stop is the ratio of the focal length to the diameter of a lens.

*Exposure and magnification.* If *E* is the exposure, *f* the focal length of the lens, *d* its diameter, and *M* the magnification (ratio of image to object):

$$E \propto \frac{f^2}{d^2} (M + 1)^2.$$

*Colour filters* may greatly increase definition and contrast in microphotography of stained preparations, e.g. Wratten 'M' green filter (no. 58) enhances contrast for acid fuchsin.

### Illustrations

See Cannon, H. G. (1936). *A Method of Illustration for Zoological Papers*. Published by the Association of British Zoologists. Norwich: Jarrold and Sons.

### Preparation of Manuscripts for Press

See Nuttall, G. H. F. (1940). *Notes on the Preparation of Papers for Publication in the Journal of Hygiene and Parasitology*. Cambridge University Press.

*See also the Editorial directions in the current numbers of the Journal selected for publication.*

## FACT INDEX

- Aceto-carmine fixative, 11  
 Alcohol, narcotization by, 6  
 Alcohols, strength of, 14  
 Algae, cultivation of, 63  
 Aniline blue, Bresslau's method, 61  
 Apáthy's gum-syrup, 20  
 Aqueous mounts, sealing, 21  
 Arthropoda, fixation of, 9  
 Arthropods, mounting, 1, 23  
 Azan stain, 38, 43
- Bacteria, methods for, 62**  
 Benzene, 19, 48  
 Birefringence, 1  
 Borax carmine, 23  
 Bouin fixative, 9  
 Buffer solutions, 69
- Calcareous structures, preservation of, 12**  
 Camera lucida, 49  
 Carmalum, Mayer's, 39, 46  
 Carnoy fixative, 11  
 Cedar oil, clearing by, 19  
 Cell outlines, Robinow's method, 25  
 Celloidin embedding, 33  
 Celloidin-paraffin, Peterfi's, 29  
 Cellophane compressorium, 3  
 Champy fixative, 58  
 Chitin, softening of, 28; stains for, 55  
 Chlorazol black, 24, 39, 47  
 Chromosomes, methods for, 11  
 Cilia, slowing of, 3  
 Cilia and flagella, stains for, 57, 61  
 Ciliata, fibrillar systems, 61  
 Clearing agents, 19  
 CO<sub>2</sub>, narcotization by, 7  
 Collagen, stains for, 41, 43, 44, 55  
 Colour filters, 39, 70  
 Crystal violet, 61  
 Cytoplasmic fixatives, 11  
 Cytoplasmic inclusions, 55
- Dehydration, 13; of small objects, 15; chart, 15 et seq.**  
 Delicate objects, mounting, 23  
 Diatoms, cultivation of, 63  
 Double embedding, 35  
 Drawing, 49  
 Dubosq-Brasil fixative, 9
- Egg cells, methods for, *see* Yolk cells  
 Elastic fibres, stains for, 55  
 Electron microscope, 2  
 Embedding, 30  
 Enzyme distribution, 57  
 Eosin, 39  
 Ester wax, 28  
 Ether, narcotization by, 7  
 Ethyl urethane, narcotization by, 7
- Fat, stains for, 55**  
 Feulgen's reaction, 56  
 Flemming with reduced acetic fixative, 58  
 Flemming-without-acetic fixative, 11  
 Formaldehyde-calcium (Baker's) fixative, 12  
 Formalin fixatives, 12  
 Formol, *see* Formalin  
 Formol-bichromate (Smith's) fixative, 13  
 Formol-silver, Horváth's stain, 61  
 Freezing-drying fixation, 75  
 Frozen sections, embedding, 26; staining, 27
- Giemsa stain, 60  
 Glycerine alcohol, storage in, 20  
 Glycerine jelly, 21  
 Glycogen, stains for, 55  
 Gum-chloral mountant, 23
- Haemalum, Mayer's, 38, 46**  
 Haematoxylin, alcoholic, iron, 60; Ehrlich's, 24; Heidenhain's iron, 37, 39  
 Hanging drop, 2  
 Heat absorption, 3  
 Heat, narcotization by, 7  
*Helix*, bleeding of, 65  
 HgCl<sub>2</sub>, removal of, 18  
 Humidity, 69
- Identification of organisms, 69**  
 Illustrations, 70  
 Invertebrates, cultivation of, 63  
 Isolated cells, Goodrich's method, 4; Ranvier's method, 4  
 Isotonic solutions for sea water, 64
- Lipoids, fixation of, 12; stains for, 27**

- Liquid paraffin, 20  
 Living condition, resemblance to, 23  
 Living material, 2
- Mallory's triple stain, 38, 41  
 Masson's trichrome stain, 38, 44  
 Methods of observation, 1  
 Menthol, narcotization by, 7  
 Methyl benzoate, clearing by, 19  
 Methyl blue-eosin, Mann's, 38, 45  
 Methyl green-acetic, 57  
 Methyl salicylate, clearing by, 19  
 Methylene blue, intra-vitam, 54, 75  
 $MgCl_2$ , narcotization by, 6  
 Micro-anatomical fixatives, 8  
 Microdissection, 3  
 Micrometry, 53  
 Minute dissections, 4, 22  
 Mounting large objects, 25  
 Mounting media, 20  
 Mounting small objects, 25  
 Mucin, stains for, 55
- Narcotics, 6  
 Narcotization, sessile animals, 6; waxed slip method, 5  
 Nervous system, methods for, 54  
 Noland's stain, 57  
 Nomenclature, rules for, 69  
 Nuclear fixatives, 11  
 Nuclear stains, 37, 56, 57
- Oil-immersion objectives, 2  
 Orange G, 39  
 Orientation, 30  
 Osmic oxide, fixative, 58
- Paraffin impregnation, 28  
 Peterli's method, 29  
 Phase-difference microscopy, 1  
 Phosphatase, detection of, 57, 76  
 Photography, 70  
 Picro-Mallory stain, 38  
 Plant tissues, methods for, 62  
 Polarized light, 1  
 Polyvinyl alcohol, 22  
 Preparation of MS., 70
- Preservation of shape, 5  
 Projection, drawing by, 49  
 Protozoa, fixation of, 58; sections of, 59
- Reconstruction, graphic, 50  
 Reference books, viii  
 Refractive indices, 2, 20  
 Ripart and Petit's fluid, 23  
 Rousselet's solution, 7
- Saline media, fresh-water and terrestrial invertebrates, 67; marine invertebrates, 65, 66; vertebrates, 67
- Scalpels, 4  
 Schaudinn fixative, 57  
 Sea water, composition, 63  
 Section cutting, 31  
 Sections, fading of, 48; preservation of, 48  
 Setae and spicules, mounting to show, 22  
 Softening dried or dehydrated material, 14, 20  
 Specific constituents, 55  
 Storage media, 20  
 Strassburger-Flemming solution, 20  
 Sudan stains, 27  
 Susa fixative, 8
- Thick sections, celloidin, 33  
 Tissue culture, 3  
 Tobacco smoke, narcotization by, 7  
 Tracheae, demonstration of, 22  
 Transference of sections to slides, 31  
 Trioxyhaematin, Hansen's iron, 37, 40
- Washing, 18  
 Waterman's wax, 28
- Xylene, clearing by, 19
- Yolk cells, clearing, 19; dehydration of, 14; fixation of, 13; impregnation by paraffin, 29, 30
- Zenker fixative, 10

## REFERENCE INDEX

- Allen, 70  
 Ambronn and Frey, 1  
 v. Ardenne, 2  
  
 Baker, viii, 12, 26, 55  
*B.D.H. Standard Stains*, 62  
 Beck, viii  
 Bethe and Berger, 68  
 Bialaszewicz, 68  
*Bibliography of the British Flora and Fauna*, 69  
 Bresslau, 61  
*Brit. J. Photogr. Alm.*, 70  
 Burch and Stock, 1  
 Buxton, 69  
  
 Cannon, 24, 47, 70  
 Carleton, viii  
 Cole, 68  
 Conn, 47  
 Cowdry, viii  
  
 Danielli, 76  
 Darlington and La Cour, 11  
 Darrow, 47  
 Dennell, 33, 53  
 Dobell, 60  
 Downs, 22  
  
 Eyre, 62  
  
 Gage, viii  
 Galtsoff and others, 63  
 Gatenby, 3  
 Gatenby and Painter, viii  
 v. Gelei, 61  
 Gersh, 75  
 Glick, 57  
 Gomori, 57  
 Goodrich, 4  
 Gross, 63  
  
*Handbook of Physics and Chemistry*,  
 2  
 Harding, 4  
 Heidenhain, 49  
 Hill, 68  
 Hill and Kupalov, 68  
 Hobson, 68  
 v. Horváth, 61  
 Hyman, 69  
  
 Keys and Hill, 68  
  
 Komp, 4  
 Krogh, 68  
  
 Lang, 75  
 Langeron, vi 1  
 Lison, viii, 50  
 Lissmann, 5  
 Lubkin and Causten, 22  
  
 Macallum, 68  
 McClendon, 63  
 McClung, 3, 75  
 MacConnell, 54  
 McFarlane, 38  
 Mackie and McCartney, 62  
 Maluf, 68  
 Mansfield Clark, 69  
 Manton, 9  
 Martin, 1  
 Mines, 68  
  
 Nayas and Falk, 64  
 Norman, 50  
 Nuttall, 70  
  
 Petersen, 39  
 Picken, 1, 68  
 Pringle, 68  
 Pringsheim, 63  
 Pryor, 55  
 Pumphrey, 68  
 Pusey, 50  
  
 Ramsay, 69  
 Reisinger, 54  
 Robertson, 68  
 Robertson and Webb, 63, 68  
 Robinow, 25  
 Roncis, viii  
  
 Schlatter, 68  
 Steedman, 28  
 Strangeways and Canti, 10  
  
 Taylor, 61  
  
 Waterman, 28  
 Webb, 63, 68  
 Wells and Ledingham, 68  
 Wilson, 8, 30, 35, 50  
 Winchell, 1  
 Winterstein, 68



## ADDENDA

### Fixation (see p. 8).

*Freezing-drying.* This method preserves tissues with probably less chemical or physical change than any other. Tissues are plunged into *isopentane* cooled to  $-190^{\circ}$  C. in liquid air. The tissue is thus fixed by instant freezing before disturbance of structure through formation of large ice crystals. It is then dehydrated *in vacuo* at  $-32.5^{\circ}$  C. for about 72 hr.: then placed directly in molten wax and embedded as usual. See McClung, C. E., *Handbook of Microscopical Technique* (1937), Oxford University Press, p. 647, and Gersh, H. I. (1938), *Anat. Rec.* 70, 311.

### Methylene blue fixation (see p. 55).

Vitally stained methylene blue preparations can be fixed, embedded in paraffin and prepared for sectioning by the following method (after Dr H. P. Whiting). The various operations, and particularly the use of normal butyl alcohol mixtures in the cold minimize loss of stain:

(1) Fix for about 8 min. at  $0^{\circ}$  C. in saturated ammonium picrate in isotonic saline.

(2) Transfer to 8% ammonium molybdate at  $0^{\circ}$  C. and leave overnight.

(3) Wash in tap water at  $0^{\circ}$  C.

(4) Transfer through the following series (see Lang, A. G. (1937), *Stain Tech.* 12, 113) for 30 min. in each at  $0^{\circ}$  C.:

	Water	95% ethyl alcohol	N-butyl alcohol
i	43	30	27
ii	30	30	40
iii	18	27	55
iv	9	21	70
v	3	12	85
vi	0	0	100

(5) Transfer to  $\frac{1}{2}$ N-butyl alcohol +  $\frac{1}{2}$  methyl benzoate at  $0^{\circ}$  C. for 20 min.

(6) To pure methyl benzoate at  $0^{\circ}$  C., for 20 min.

(7) To  $\frac{1}{2}$  methyl benzoate +  $\frac{1}{2}$  liquid paraffin at room temperature, for 20 min.

- (8) To pure liquid paraffin for 30 min. or longer.
- (9) Embed as usual.

**Alkaline Phosphatase** (see p. 57). (See Danielli, J. F. (1945), *J. exp. Biol.* 22, 110.)

Preservation of enzymes *in situ* necessitates prevention of their solution and of their destruction during fixation. To show distribution of alkaline phosphatase:

- (1) Fix pieces of tissue not more than 3 mm. long for 2 hr. in 80 % alcohol.
- (2) Dehydrate with three changes of 2 hr. each of absolute alcohol.
- (3) Clear with three changes of 2 hr. each of cedar oil (or benzene if at a low temperature).

It is an advantage to execute stages 1-3 in a refrigerator.

(4) Impregnate with paraffin at a low temperature (below 60° C.), and for not more than 2 hr., to prevent destruction of enzyme. Two changes of Gurr wax, m.p. 54° C., suffice. Embed (store in the cold). Section as usual.

(5) Lay paraffin ribbon on *chemically clean* slides (no albumen adhesive). Flatten at 37°, and dry in a desiccator overnight at room temperature.

(6) Then to xylene (three changes); to absolute alcohol (two changes). 1 min. each stage.

(7) To 0.1 celloidin in equal volumes of alcohol and ether (1 min.). Dry in air. Transfer to 50 % alcohol (1 min.); to 30 % alcohol (1 min.); to distilled water (5 min.). If sections adhere satisfactorily without celloidin they can be brought down through the alcohols to water in the ordinary way.

(8) (a) Incubate at 37° ( $\frac{1}{2}$ -2½ hr.). Invertebrate tissues may incubate at lower temperatures.

#### *Incubation medium*

2 % sodium veronal (as buffer to pH 9 to 9.3), 20 c.c.

2 % sodium  $\beta$ -glycerophosphate, 20 c.c.

2 % calcium nitrate, 10 c.c.

(10 % magnesium chloride 1 c.c. may be added to increase activation of enzyme.)

Add distilled water to 100 c.c.

(b) Incubate a control in similar medium with distilled water in place of glycerophosphate.

(9) Wash in 1 % calcium nitrate (5 min.).

(10) Wash in 1 % cobalt nitrate (5 min.).

(11) Wash twice with distilled water (not more than 1 min.).

(12) Treat with ammonium sulphide; a few drops of a freshly made concentrated solution in about 100 c.c. distilled water (1 min.).

(13) Wash in tap water (5 min.).

(14) Dehydrate, clear and mount in balsam. Counterstain en route if desired with *eosin* or *light green*.



**MEMORANDA**











